



權億科技股份有限公司
Master Wave Technology Co., Ltd.

承認書

APPROVAL SHEET

Customers: 啟碁科技股份有限公司

Customer Model No.:

Master Wave Model No.: 98151MRSX004-220

Product Description: 8151 Replacement Ant.

Issue Date: 2009/2/10

REV.: 00

客戶承認用印 Customer Approved		權億承認用印 Confirmation Signature	
			
核准 Approve	主管 Chief	承辦 Responsible	
Hero	Hero	S. Y. Liu	

中壢：桃園縣中壢市南園二路1巷20號2樓

電話：03-451-9540

FAX：03-451-9542

東莞廠：廣東省東莞市常平鎮木掄工業區

蘇州廠：江蘇省蘇州市角直鎮吳淞南路95號

Antenna Total Solution Provider



Table of Contents

Item

1. Antenna Specifications

- Drawing
 - Electrical Properties
 - Mechanical Properties
-

2. Test Report

- Electrical test
 - Pattern test
-

3. Material Certifications

- Connector
-

4. Packing

- PE Bag
- Carton

Modification History:

REV.	Date	Content
00	2009/2/10	

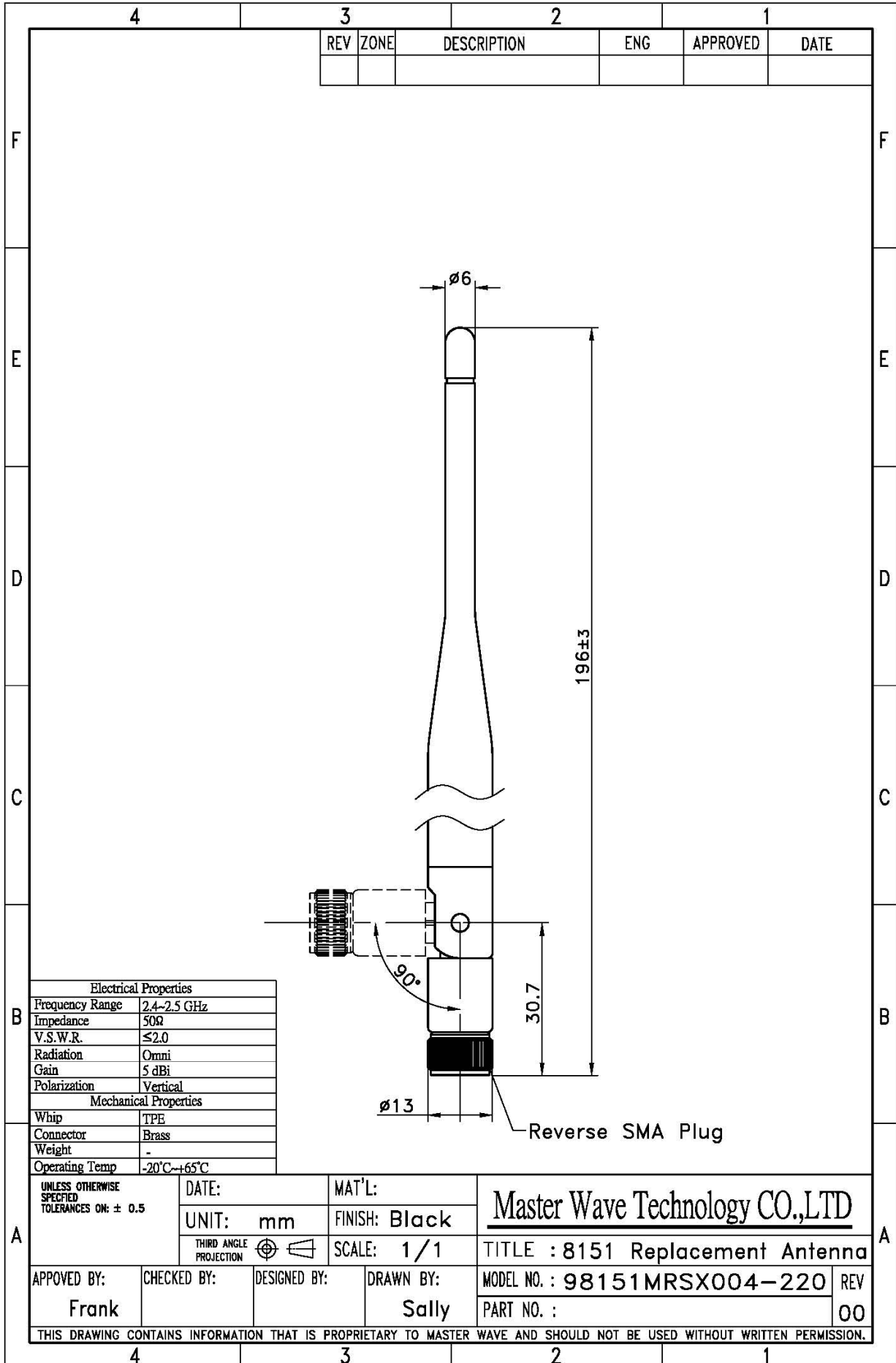



Electrical Properties

Type	Replacement Antenna
Frequency range	2.4~2.5 GHz
Impedance	50 Ohms
VSWR	≤ 2.0

Mechanical Properties

Material	TPE
Connector	Reverse SMA Plug
Dimension(L*W*H)	196* \varnothing 13.0



Connector

SMA

Electrical Properties	Impedance	50 ohm
	Frequency Range	0~6 GHz
	V.S.W.R	≤ 1.5
	Working Voltage	$\leq 250V_{rms}$
	Dielectric Withstanding	$\leq 670 V_{rms}$
	Voltage Insulation Resistance	≥ 2000 Megohms
	Contact Resistance	Center contact: 3.0 Milliohms (Max.) Outer contact: 2.0 Milliohms (Max.)
	Recommended coupling nut torque	4.0 in. lbs. ~ 8.8in. lbs.
	Coupling nut retention force	≥ 50 lbs.
	Contact captivation axial	≥ 5 lbs.
	Durability (mating)	≥ 500 cycles
Environmental Ratings	Operating Temperature	-65°C ~ +165°C
	Thermal shock	MIL-STD-202,METHOD 107,Condition B
	Corrosion	MIL-STD-202,METHOD 101,Condition B
	Shock	MIL-STD-202,METHOD 213,Condition I
	Vibration	MIL-STD-202,METHOD 204,Condition D
	Moisture Resistance	MIL-STD-202,METHOD 106
Material Specifications	Material Data	Material
	Body	Brass
	Center Contact	Phosphor Bronze
	Insulator	Teflon or Delrin



Electrical Test

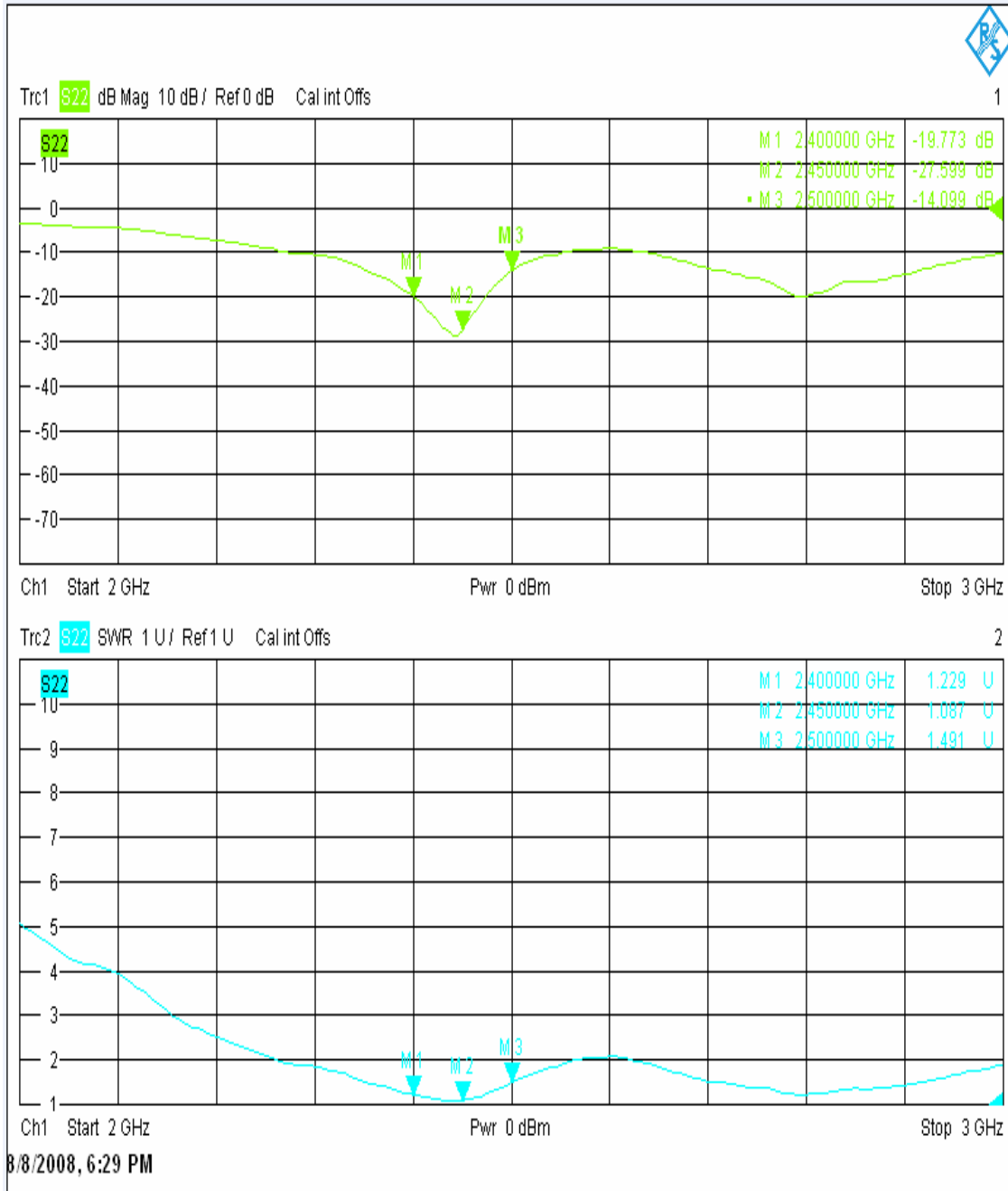



Pattern Test

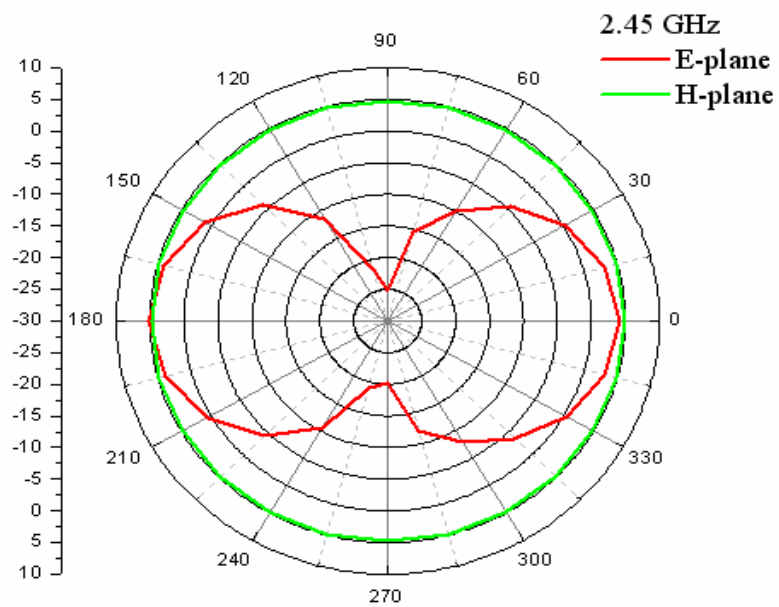
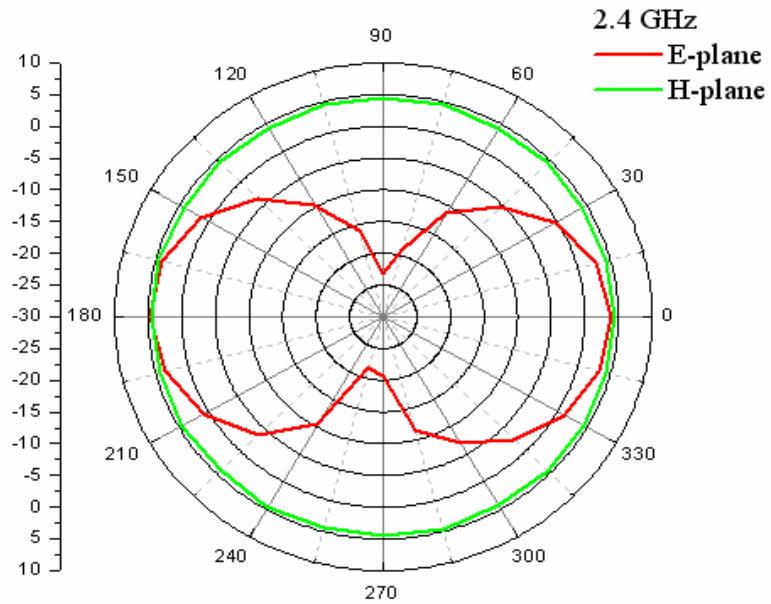



Pattern Test

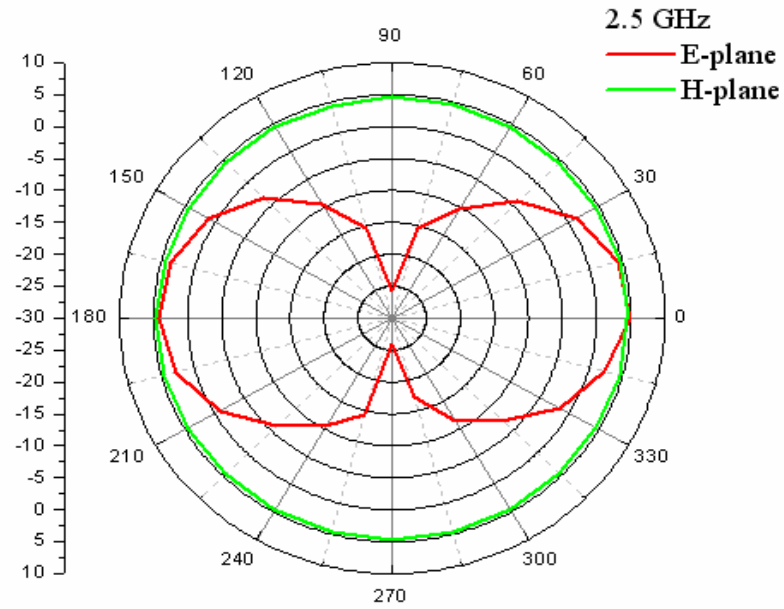

AP20-050-MIMO-19

MIMO Directional Antenna

Technical Sheet

Specifications

Model	AP20-050-MIMO-19
Freq.Range-MHz	5125-6100
Bandwidth-MHz	975
Gain-dBi	19(Vertical)
	16(dual slant)
Hor.Beamwidth-°	22(Vertical)
	20(dual slant)
Ver.Beamwidth-°	14(Vertical)
	19(dual slant)
VSWR	≤1.8
Isolation-dB	≥25
F/B Ratio-dB	≥25
Max.power-W	10
Impedance-Ω	50
Polarization	±45° and vertical
Connector	3×N-type female
Dimensions-mm	305×305×12
Weight-Kg	0.8(without clamps)
Mounting	pole

Applications

- I 5.8GHz WLAN system
- I 5.8GHz UNII/ISM system
- I Point to point or point to multipoint

Features

- I Broad band, 5.1/5.5/5.8/6.1GHz
- I Triple polarization
- I MIMO application
- I High gain, Low VSWR
- I Strong corrosion resistance ability



Installation sketch

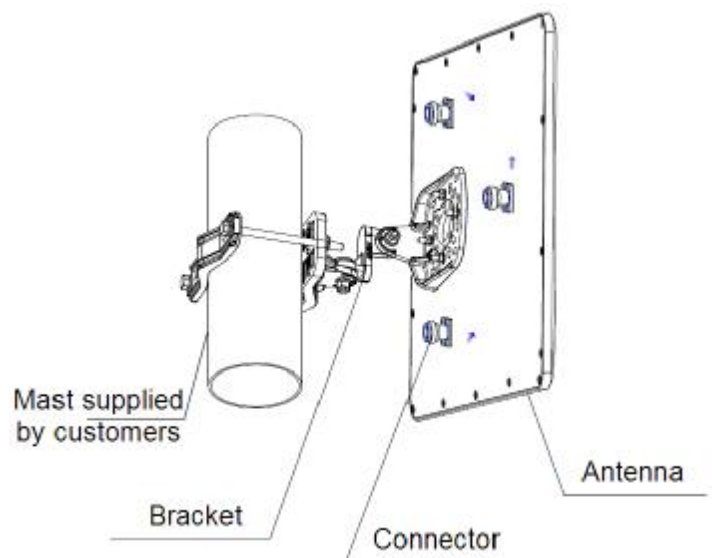

REV	DATE	DESCRIPTION
X1	6/24-2005	New Issue
X2	7/4-2005	Modify all

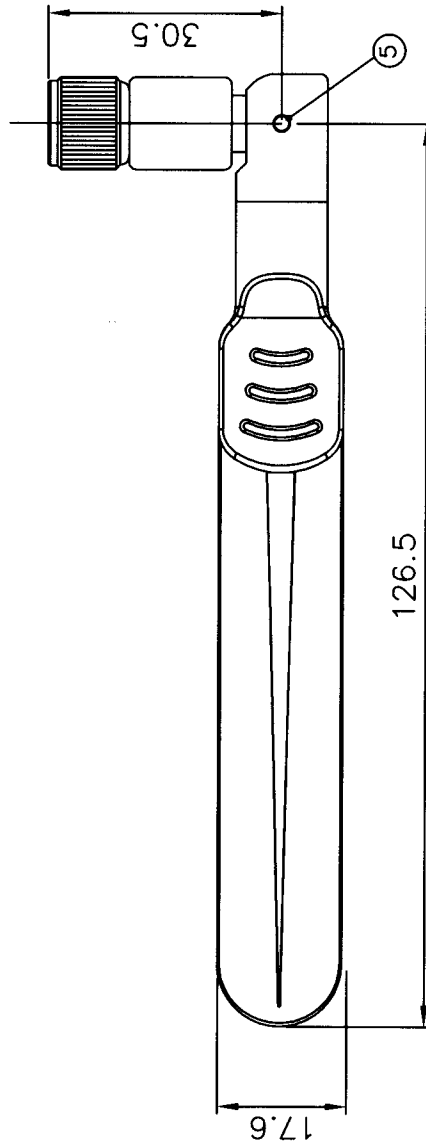
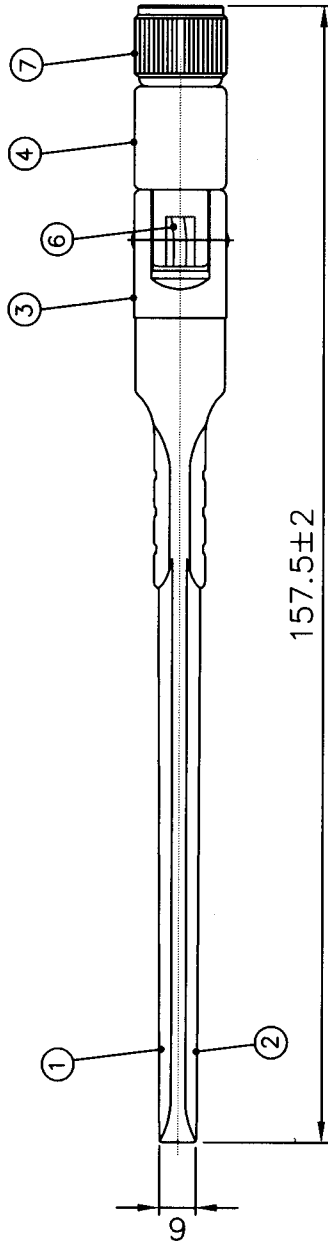

PE Bag
Shrink Line

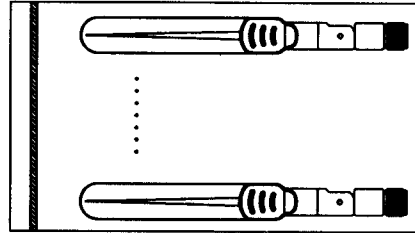

Packing : 10 pcs/bag

NO	DESCRIPTION	QTY	REMARK
7	Connector	1	SMA Plug Straight Reverse
6	Cable	1	RG-178 Cable
5	Rivet	1	POM ; Black
4	Antenna Base	1	PBT Color : Black
3	Antenna Base	1	PC+ABS , Color : Black
2	Antenna Housing(S)	1	PC+ABS , Color : Black
1	Antenna Housing(M)	1	PC+ABS , Color : Black

CUSTOMER:	Fire tide
PART NO :	
PARTNAME:	RF Antenna Assembly
W.Y/PNO :	C812-510012-A
REV	UNIT FILE :
X2	m/m SHEET :
	1/1

Wha Yu
INDUSTRIAL CO.,LTD.
講裕實業股份有限公司

THIS DRAWING, AND ITS INHERENT DESIGN CONCEPTS, ARE THE PROPERTY OF WHA YU AND AS SUCH MAY NOT BE COPIED, REPRODUCED, OR GIVEN TO THIRD PARTIES WITHOUT THE WRITTEN CONSENT OF WHA YU.

CUSTOMER'S SIGNATURE

RF Antenna Assembly
P/NO :C812-510012-A SPEC : 5GHz

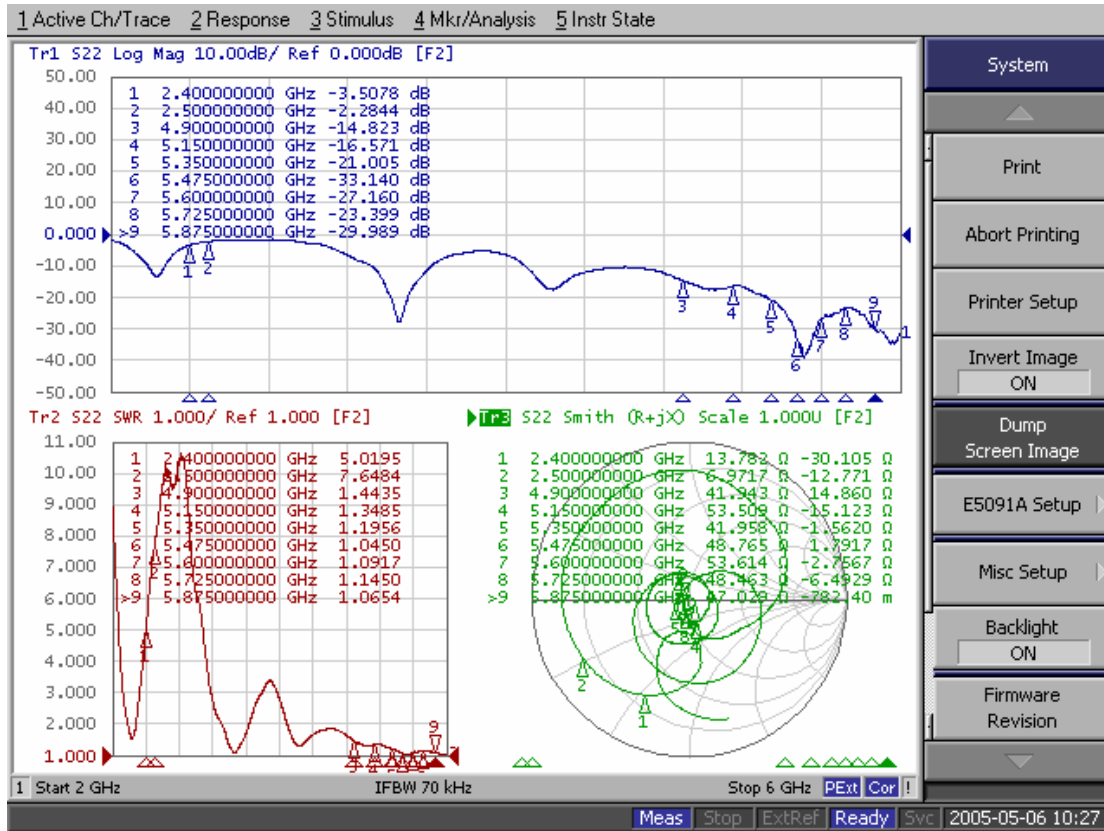



Far-field amplitude of C812-510012-A.nsi

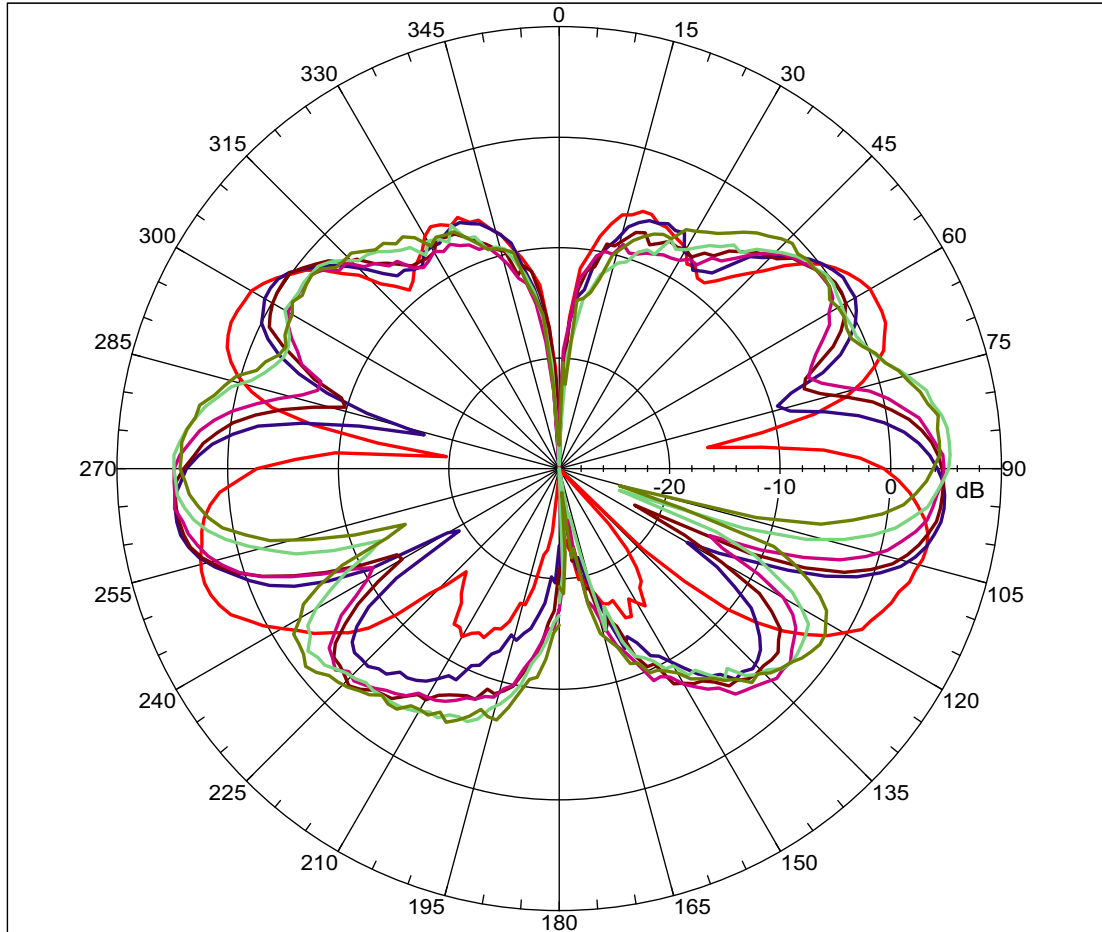
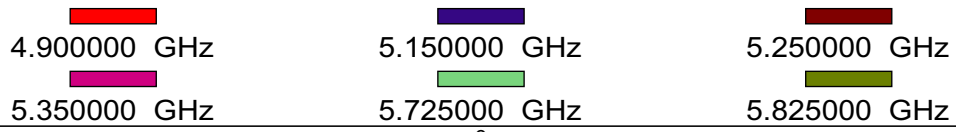



Far-field amplitude of C812-510012-A.nsi

4.900000 GHz 5.150000 GHz 5.250000 GHz
5.350000 GHz 5.725000 GHz 5.825000 GHz

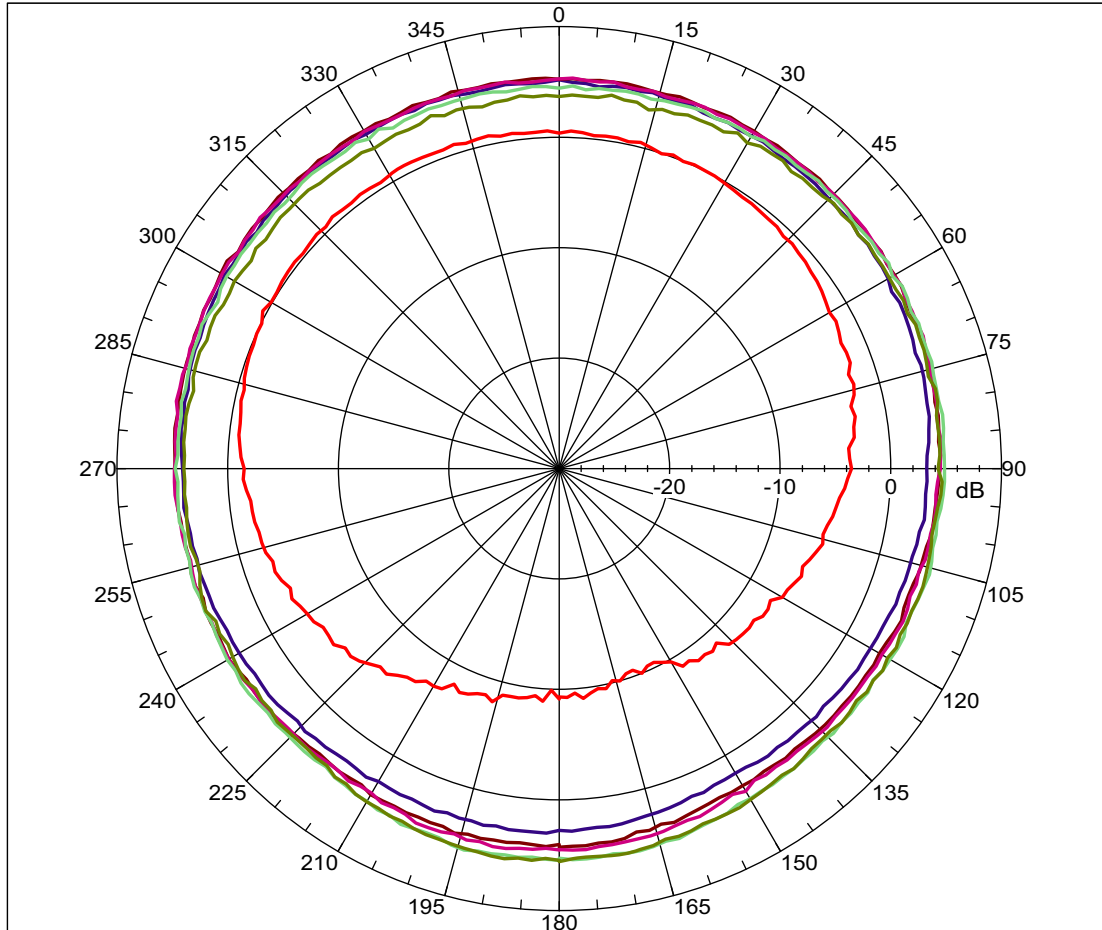

**5.125–6.1 GHz Triple Polarization MIMO Subscriber Antenna
MA-WA55-TPMIMO**

Radiations Patterns

Frequency 5500 MHz
Gain, typ. Vertical 19 dBi Slant 17.5 dBi

Vertical Polarization

Azimuth Pattern

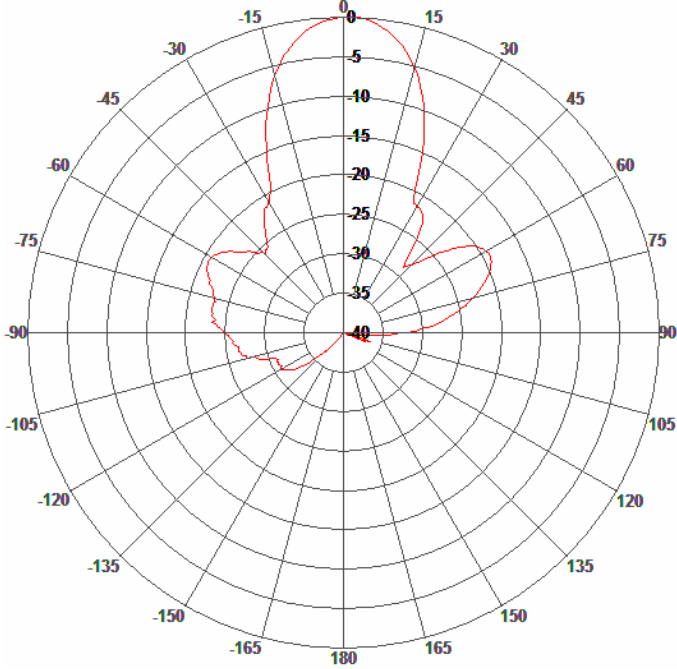

Elevation Pattern

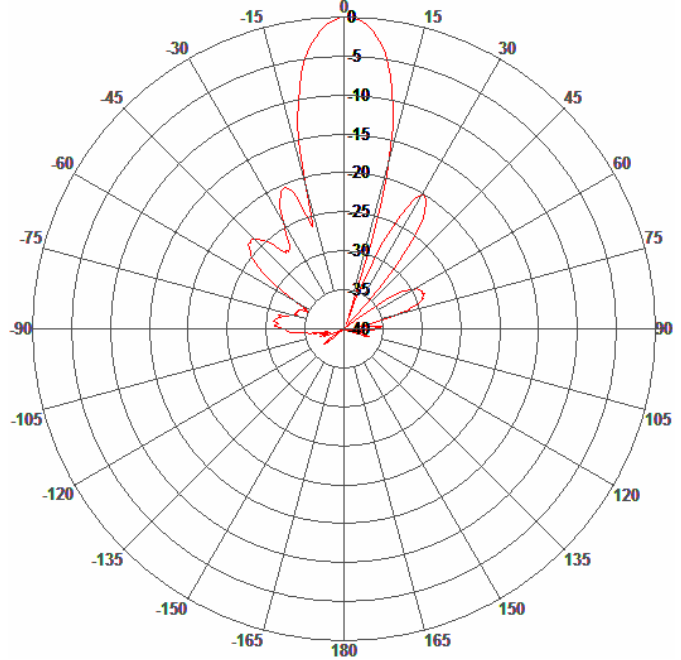

Slant $\pm 45^\circ$ Polarization

Azimuth Pattern

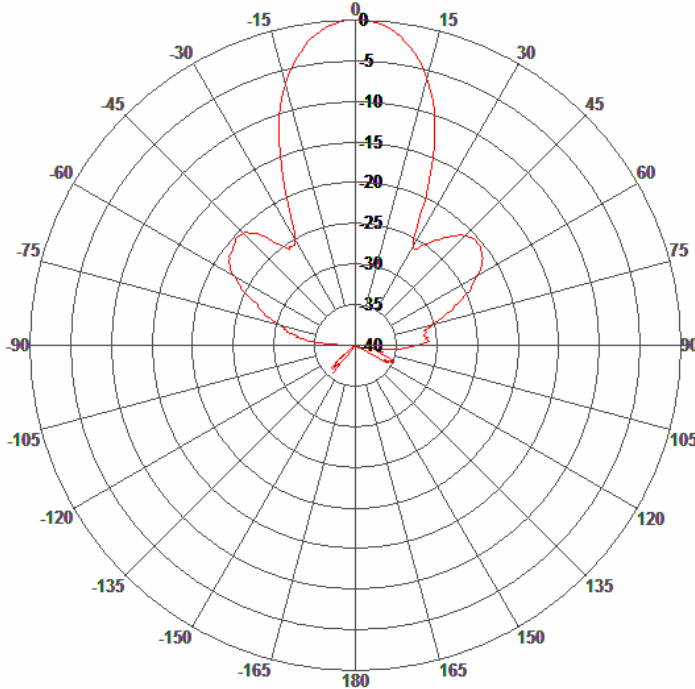

Elevation Pattern

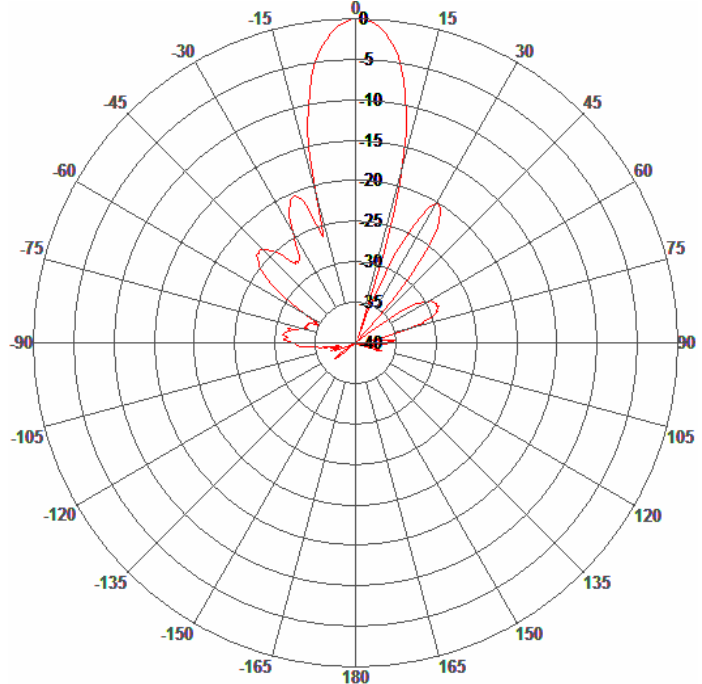

**2.3-2.7 GHz Base Station Antenna, 90°
MA-WD24-13MIMO**

Radiations Patterns

Frequency 2550 MHz
Gain, typ. 13 dBi

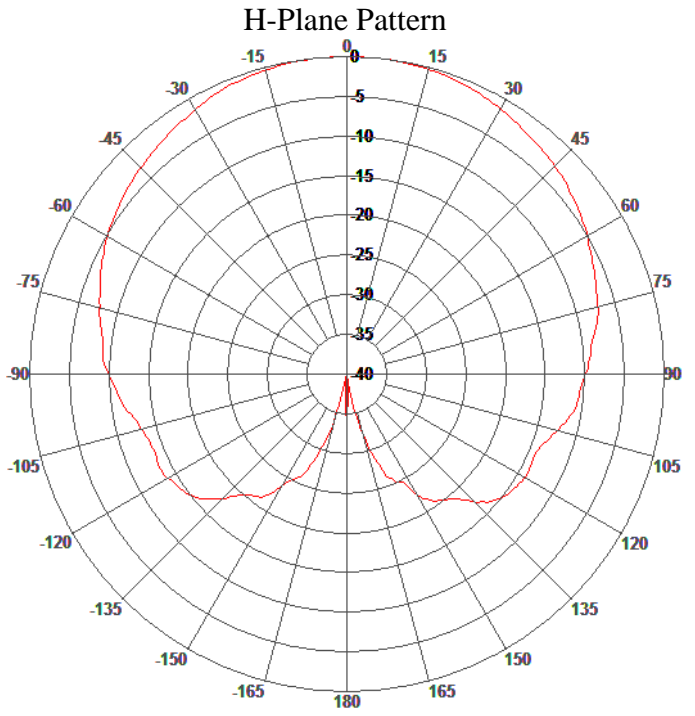
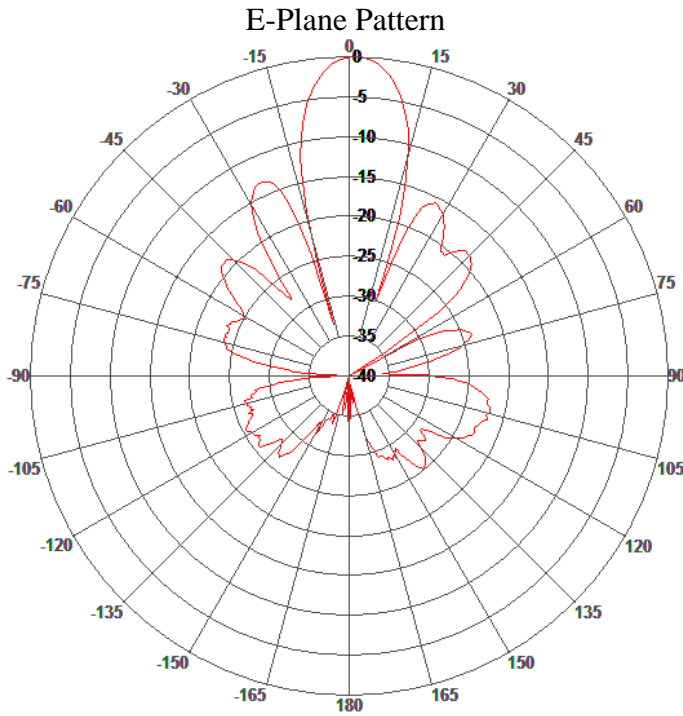

**4.9-6.1 GHz MIMO Base Station Antenna, 90°
MA-WD55-16MIMO**

Radiations Patterns

Frequency 5800 MHz
Gain, typ. 16 dBi

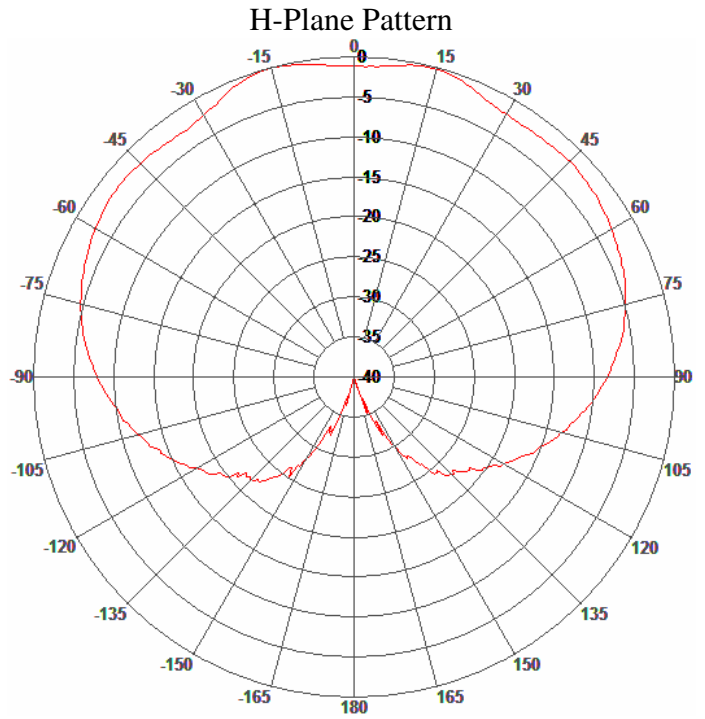
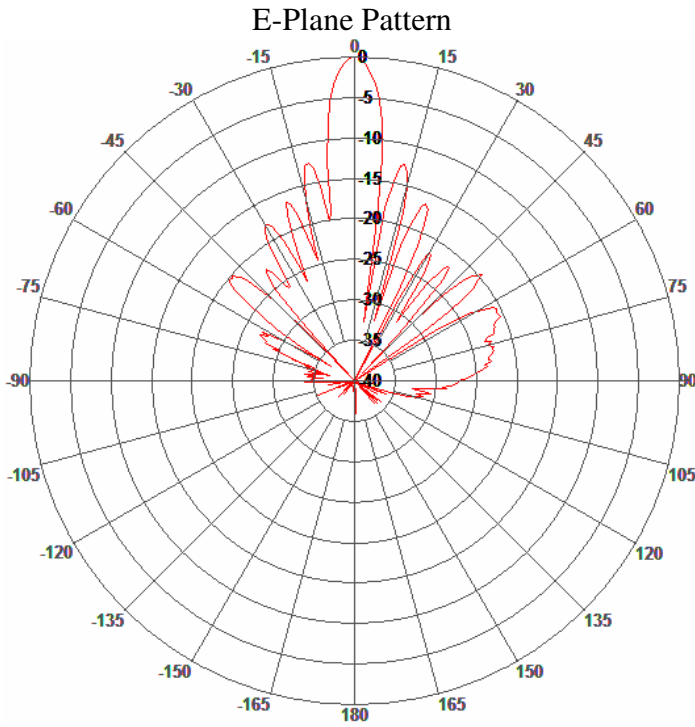

4.9 - 5.875 GHz MIMO Omni – Directional Base Station Antenna

MA-WO55-MIMONHFT9

Radiations Patterns

Frequency 5500 MHz
Gain, typ. 9 dBi

