



權億科技股份有限公司  
Master Wave Technology Co., Ltd.

## 承認書

## APPROVAL SHEET

Customers: 啟碁科技股份有限公司

Customer Model No.:

Master Wave Model No.: 98151MRSX004-220

Product Description: 8151 Replacement Ant.

Issue Date: 2009/2/10

REV.: 00

客戶承認用印 Customer Approved		權億承認用印 Confirmation Signature	
			
核准 Approve	主管 Chief	承辦 Responsible	
Hero	Hero	S. Y. Liu	

中壢：桃園縣中壢市南園二路1巷20號2樓

電話：03-451-9540

FAX：03-451-9542

東莞廠：廣東省東莞市常平鎮木埒工業區

蘇州廠：江蘇省蘇州市角直鎮吳淞南路95號

**Antenna Total Solution Provider**



## Table of Contents

### Item

---

#### 1. Antenna Specifications

- Drawing
  - Electrical Properties
  - Mechanical Properties
- 

#### 2. Test Report

- Electrical test
  - Pattern test
- 

#### 3. Material Certifications

- Connector
- 

#### 4. Packing

- PE Bag
- Carton

### Modification History:

---

REV.	Date	Content
00	2009/2/10	

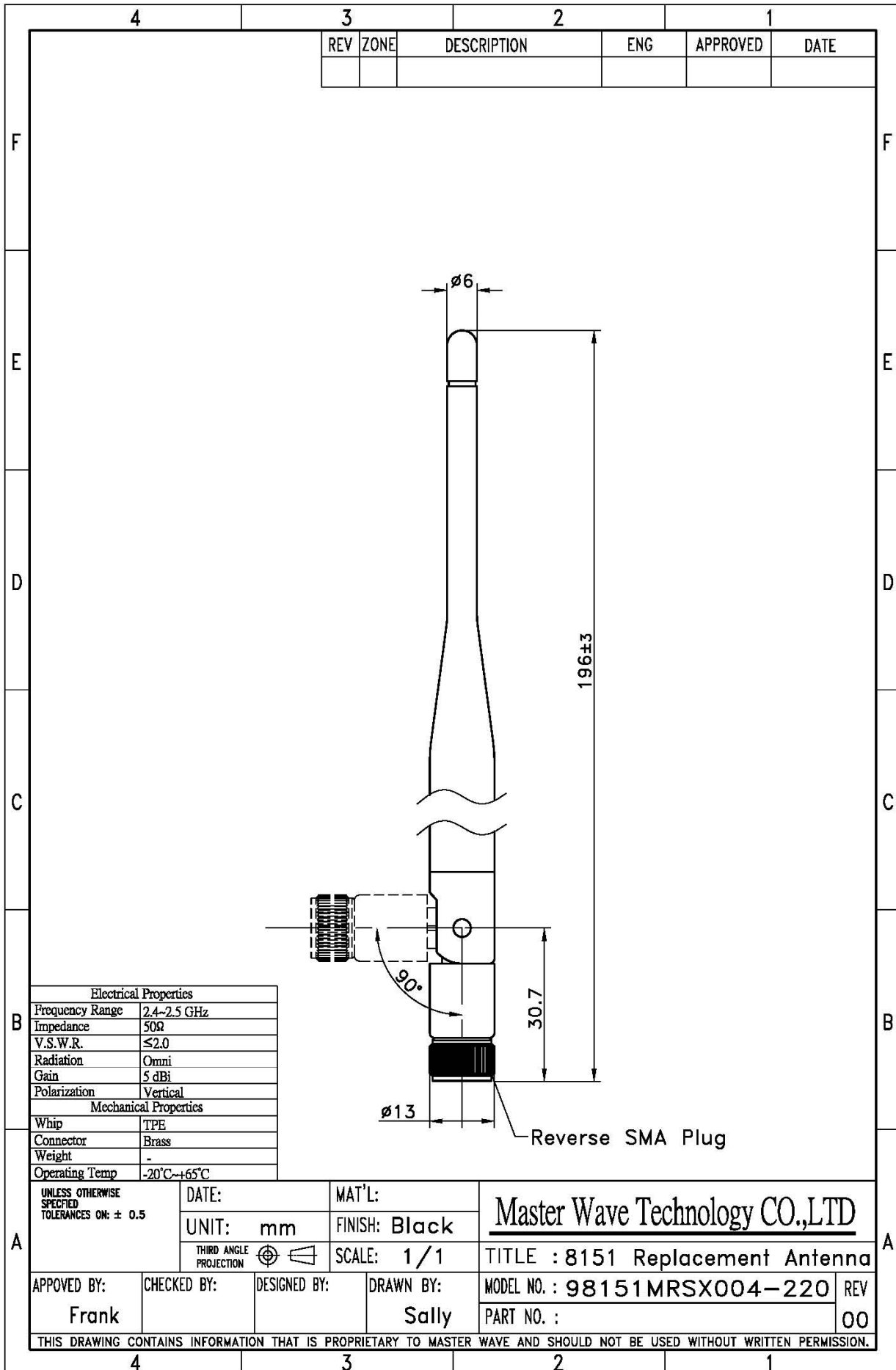



## Electrical Properties

Type	Replacement Antenna
Frequency range	2.4~2.5 GHz
Impedance	50 Ohms
VSWR	$\leq 2.0$

## Mechanical Properties

Material	TPE
Connector	Reverse SMA Plug
Dimension(L*W*H)	196* $\varnothing$ 13.0



## Connector

## SMA

Electrical Properties	Impedance	50 ohm
	Frequency Range	0~6 GHz
	V.S.W.R	$\leq 1.5$
	Working Voltage	$\leq 250V_{rms}$
	Dielectric Withstanding	$\leq 670 V_{rms}$
	Voltage Insulation Resistance	$\geq 2000$ Megohms
	Contact Resistance	Center contact: 3.0 Milliohms (Max.) Outer contact: 2.0 Milliohms (Max.)
	Recommended coupling nut torque	4.0 in. lbs. ~ 8.8in. lbs.
	Coupling nut retention force	$\geq 50$ lbs.
	Contact captivation axial	$\geq 5$ lbs.
	Durability (mating)	$\geq 500$ cycles
Environmental Ratings	Operating Temperature	-65°C ~ +165°C
	Thermal shock	MIL-STD-202,METHOD 107,Condition B
	Corrosion	MIL-STD-202,METHOD 101,Condition B
	Shock	MIL-STD-202,METHOD 213,Condition I
	Vibration	MIL-STD-202,METHOD 204,Condition D
	Moisture Resistance	MIL-STD-202,METHOD 106
Material Specifications	Material Data	Material
	Body	Brass
	Center Contact	Phosphor Bronze
	Insulator	Teflon or Delrin



## Electrical Test

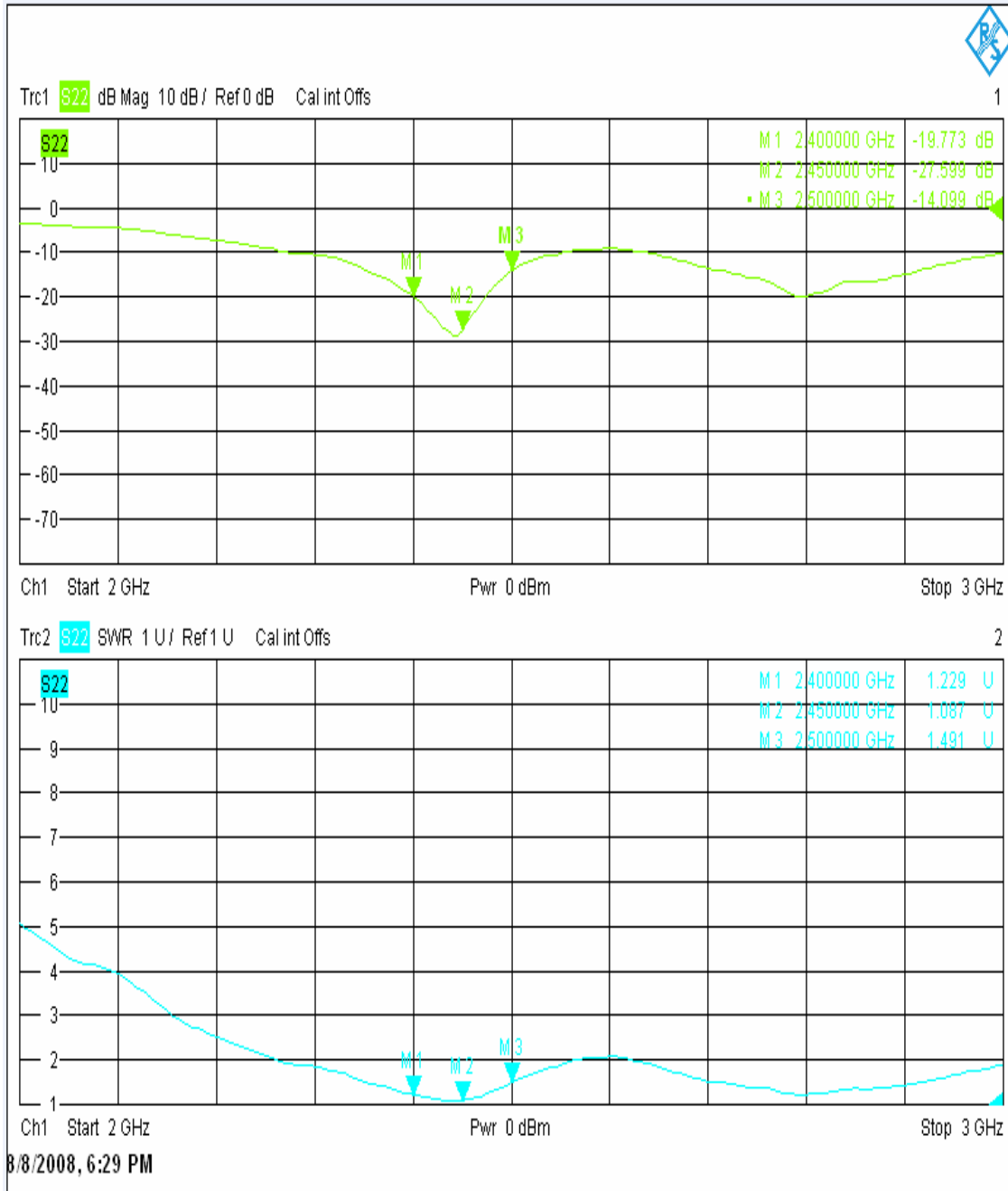



## Pattern Test

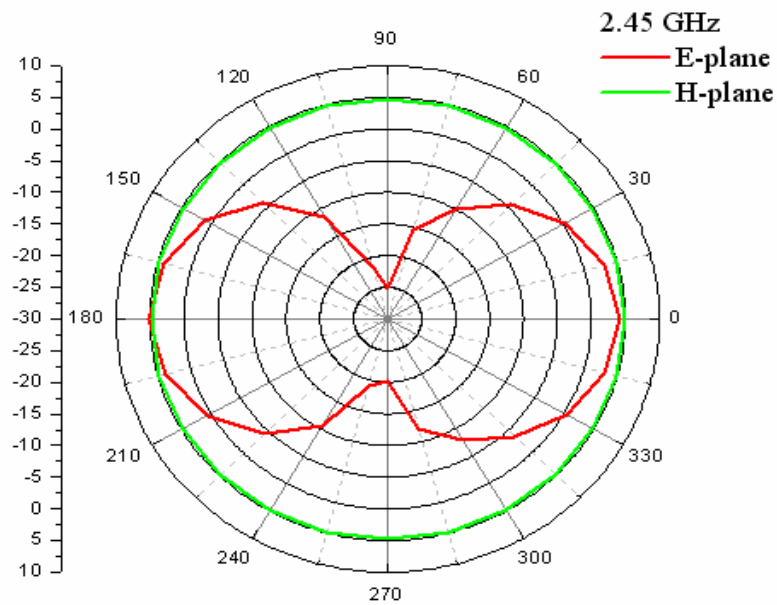
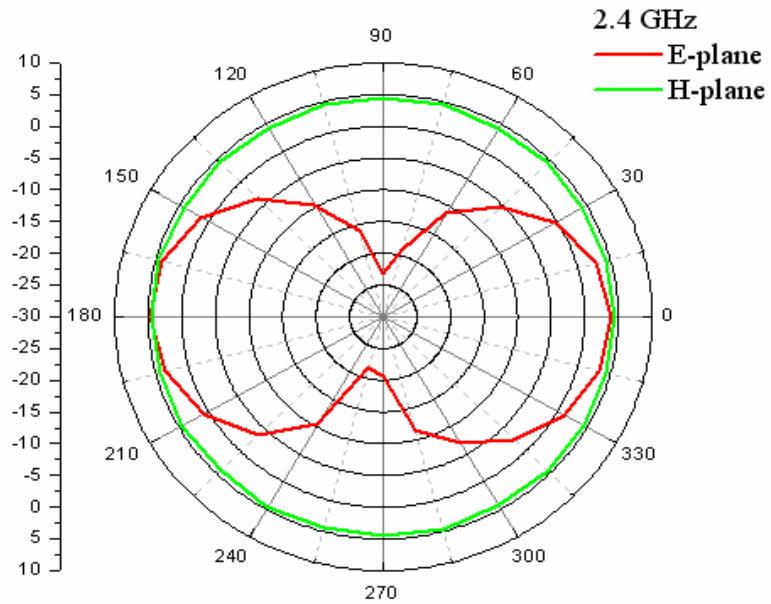



## Pattern Test

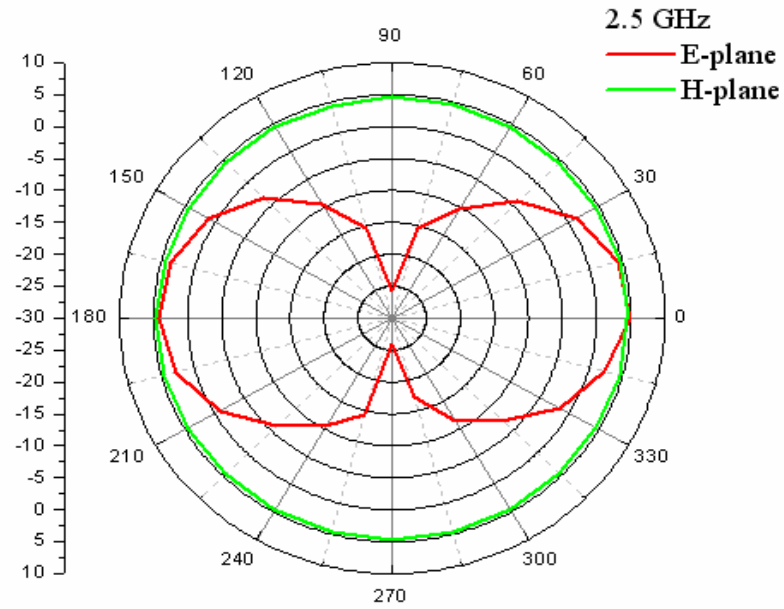





權億科技股份有限公司  
Master Wave Technology Co., Ltd.

## 承認書

## APPROVAL SHEET

Customers: 啟碁科技股份有限公司

Customer Model No.:

Master Wave Model No.: 98620ZRSX000-220

Product Description: 8620 Replacement Ant.

Issue Date: 2009/2/12

REV.: 00

客戶承認用印 Customer Approved		權億承認用印 Confirmation Signature	
			
核准 Approve	主管 Chief	承辦 Responsible	
Hero	Hero	S. Y. Liu	

中壢：桃園縣中壢市南園二路1巷20號2樓

電話：03-451-9540

FAX：03-451-9542

東莞廠：廣東省東莞市常平鎮木掄工業區

蘇州廠：江蘇省蘇州市角直鎮吳淞南路95號

**Antenna Total Solution Provider**



## Table of Contents

### Item

---

1. Antenna Specifications

-Drawing

2. Material Certifications

-Connector

### Modification History:

---

REV.	Date	Content
00	2009/2/12	

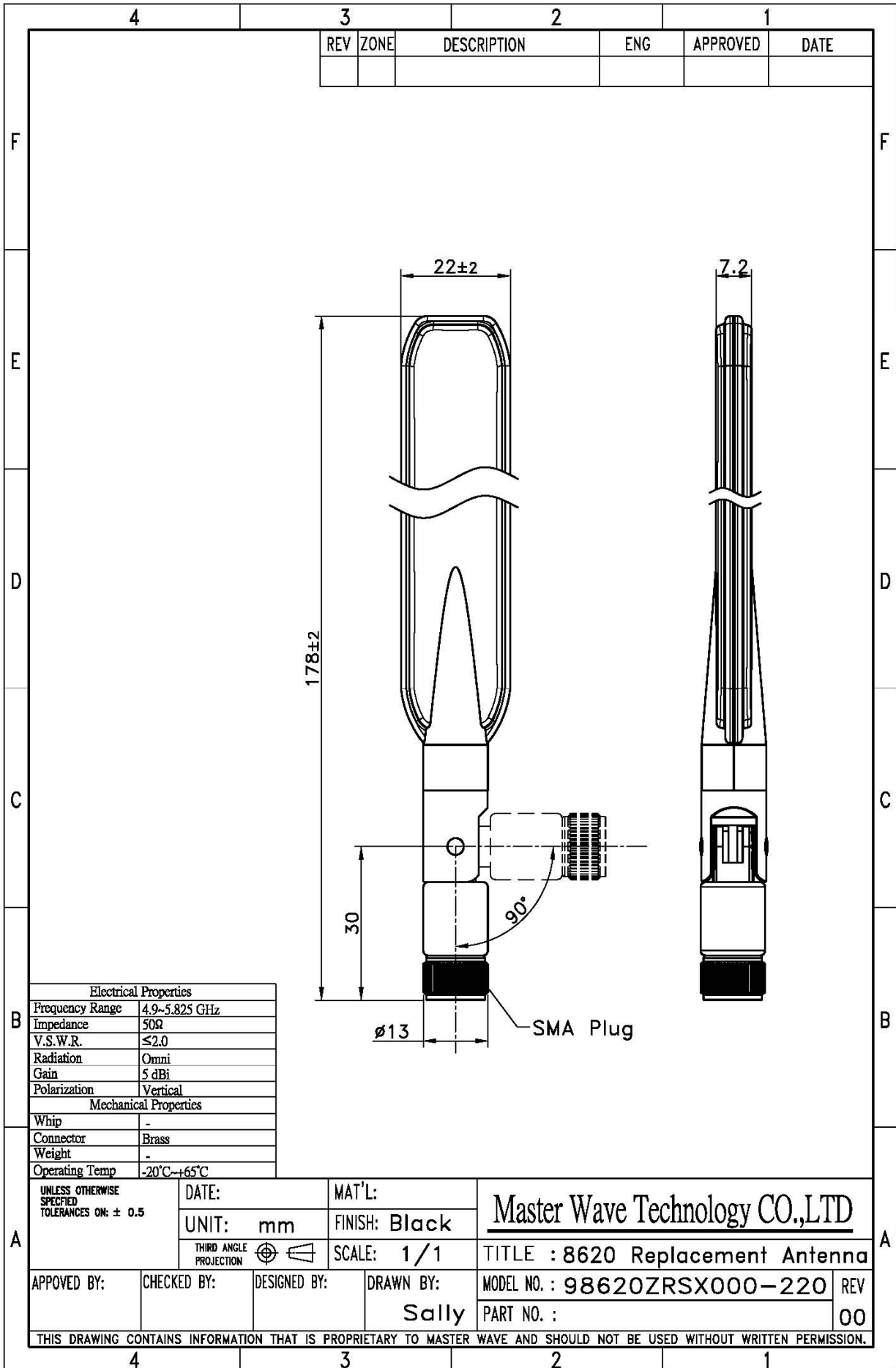



## Connector

## SMA

Electrical Properties	Impedance	50 ohm
	Frequency Range	0~6 GHz
	V.S.W.R	$\leq 1.5$
	Working Voltage	$\leq 250V_{rms}$
	Dielectric Withstanding	$\leq 670 V_{rms}$
	Voltage Insulation Resistance	$\geq 2000$ Megohms
	Contact Resistance	Center contact: 3.0 Milliohms (Max.) Outer contact: 2.0 Milliohms (Max.)
	Recommended coupling nut torque	4.0 in. lbs. ~ 8.8in. lbs.
	Coupling nut retention force	$\geq 50$ lbs.
	Contact captivation axial	$\geq 5$ lbs.
	Durability (mating)	$\geq 500$ cycles
Environmental Ratings	Operating Temperature	-65°C ~ +165°C
	Thermal shock	MIL-STD-202,METHOD 107,Condition B
	Corrosion	MIL-STD-202,METHOD 101,Condition B
	Shock	MIL-STD-202,METHOD 213,Condition I
	Vibration	MIL-STD-202,METHOD 204,Condition D
	Moisture Resistance	MIL-STD-202,METHOD 106
Material Specifications	Material Data	Material
	Body	Brass
	Center Contact	Brass
	Insulator	Teflon or Delrin

# AO-024-MIMO-8

## MIMO Omni Antenna

### Technical Sheet



#### Applications

- 2.4GHz Wlan,Wi-Fi system
- IEEE802.11b,g,n
- three 2.4GHz ports

#### Features

- high Gain, Low VSWR
- Small Size, Light weight
- Sealed with Fiberglass

#### Typical E-Plane Field Pattern

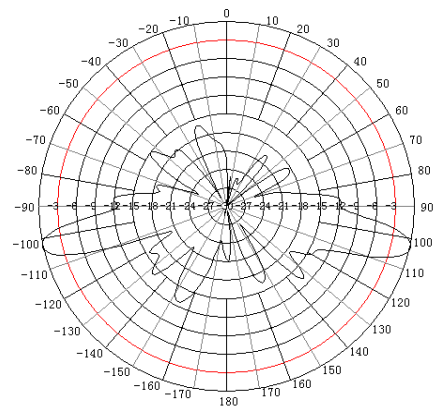

#### Specifications

Model	AO-024-MIMO-8
Freq. Range-MHz	2400~2500
Bandwidth-MHz	100
Gain-dBi	9
Beamwidth-°	E:10 H:360
Electrical Downtilt-°	10
Isolation-dB	≥25
VSWR	≤1.5
Impedance-Ω	50
Polarization	Vertical
Max. Power-W	20
Connector Type	N Female
Dimensions-mm	Φ145×600
Weight-Kg	2
Pole Diameter-mm	φ40~φ70

#### Install Sketch

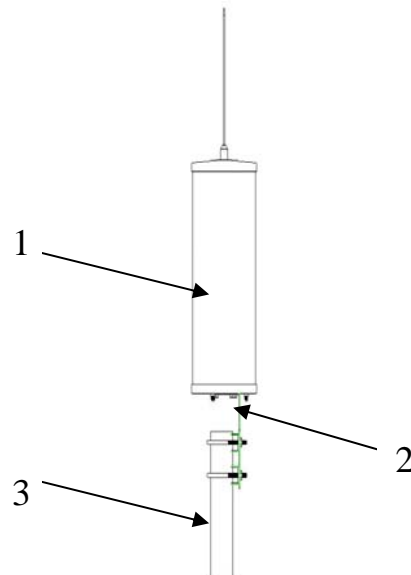

1. Antenna
2. "L" type bracket
3. Mast supplied by customer

## AP20-050-MIMO-19

### MIMO Directional Antenna

## Technical Sheet

### Specifications

Model	AP20-050-MIMO-19
Freq.Range-MHz	5125-6100
Bandwidth-MHz	975
Gain-dBi	19(Vertical)
	16(dual slant)
Hor.Beamwidth-°	22(Vertical)
	20(dual slant)
Ver.Beamwidth-°	14(Vertical)
	19(dual slant)
VSWR	≤1.8
Isolation-dB	≥25
F/B Ratio-dB	≥25
Max.power-W	10
Impedance-Ω	50
Polarization	±45° and vertical
Connector	3×N-type female
Dimensions-mm	305×305×12
Weight-Kg	0.8(without clamps)
Mounting	pole

### Applications

- I 5.8GHz WLAN system
- I 5.8GHz UNII/ISM system
- I Point to point or point to multipoint

### Features

- I Broad band, 5.1/5.5/5.8/6.1GHz
- I Triple polarization
- I MIMO application
- I High gain, Low VSWR
- I Strong corrosion resistance ability



### Installation sketch

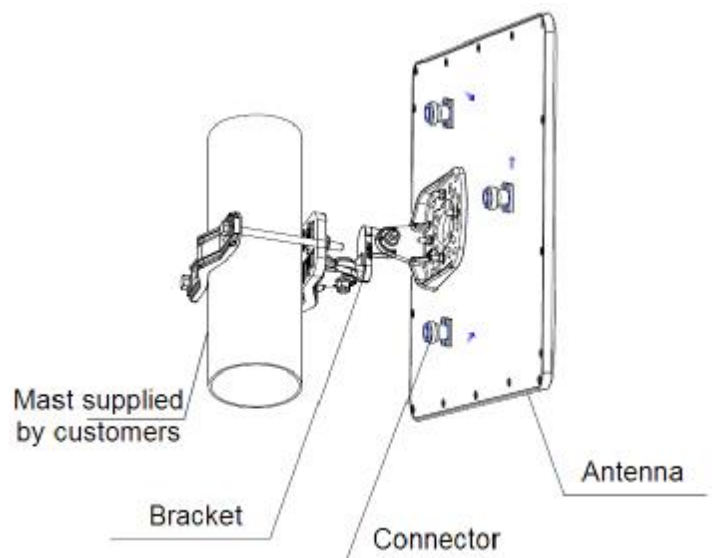

### MIMO E-plane Dual Slant

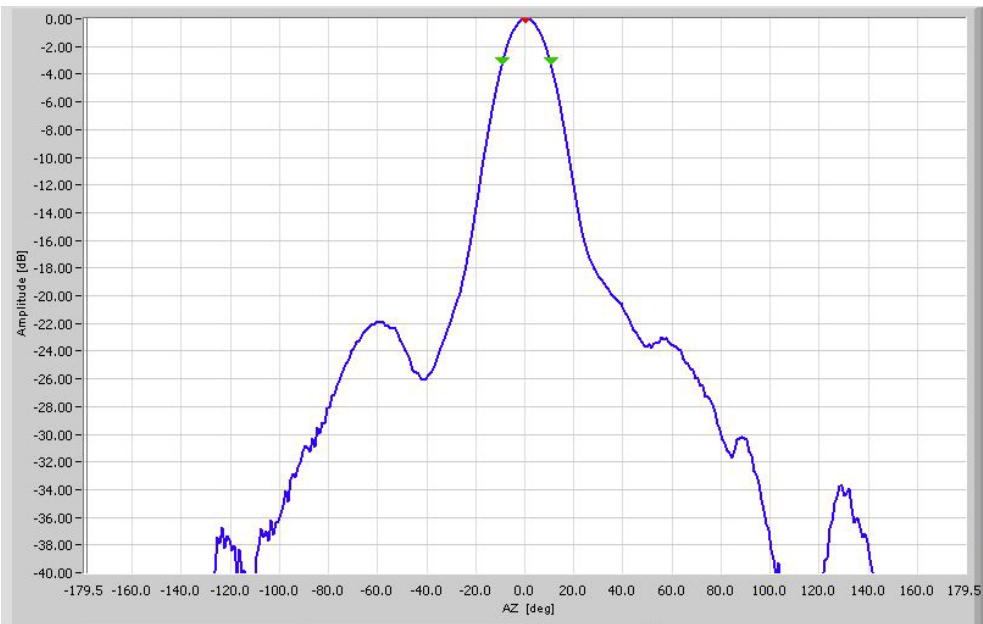

Side lobes Database Az. Ratio

No.	Ampl	Deg

AZ [deg]

Amplitude [dB]

Phase [deg]

Amplitude [dB]

Phase [deg]

Not Aligned

Normalized

Phase wrapped

Log Display

No Skirt

A	P	File Name	POL [deg]	Freq. [GHz]	ROLL [deg]	Ch.	Beam	Switch	Beam Peak [dB]			Beam Width [deg]			Null Depth [dB]		GainA dBi
									Value	[deg]	P	Value	At dB	P	Value	[deg]	
		v:\AWS55-PRO\MON-file#2-CAL.nff	90.00	5.500 G	90.00	CH1			17.82	0.50	P	19.20	3.00	P		17.82	





<b>Wide-band Panel</b>	<b>2300~2700</b>
<b>Dual Polarization</b>	<b>X</b>
<b>Half-power Beam Width</b>	<b>90°</b>
<b>Fixed Electrical Downtilt</b>	<b>0°</b>

XPo1 2300~2700MHz 90° 14dBi 0° Tilt

Electrical specifications	AS90-024-MIMO-13	
Frequency range (MHz)	2300~2500	2500~2700
Polarization	±45°	
Gain (dBi)	2×13.5	2×14
Electrical Downtilt (°)	0	
Half-power beam width (°)	Horizontal:90 Vertical:15.5	Horizontal:88 Vertical:15
Sidelobe suppression for first sidelobe above main beam (dB)	≥15	
Front-to-back ratio (dB)	≥23	
Cross-polar discrimination (dB)	≥15(±60°≥10)	
Isolation (dB)	≥30	
Impedance (Ω)	50	
VSWR	≤1.5	
Intermodulation IM3 (2×43dBm carrier)	≤-150dBc	
Maximum power (W)	200	
Lighting protection	DC Ground	



Mechanical specifications	
Connector	2×N Female
Connector position	Bottom
Height/width/depth (mm)	500×128×56
Packing size (mm)	600×230×160
Weight (kg)	1.5
Radome material	UPVC
Radome color	Gray
Mechanical tilt (°)	0~15
Operating temperature (°C)	-40~60
Rated wind velocity (m/s)	60
Suitable pole diameter (mm)	35~75
Mounting kit	JM-2400RZ1

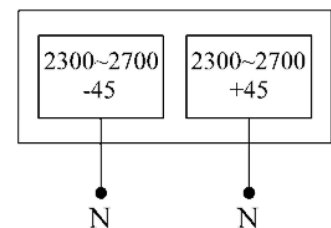

**2300~2500MHz: ±45° Polarization**

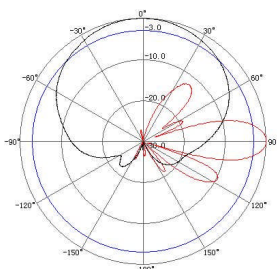

**2500~2700MHz: ±45° Polarization**

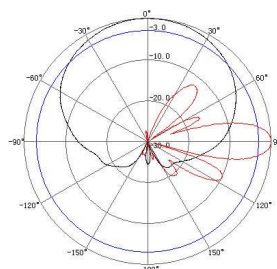

**AS90-050-MIMO-16-T 4.9-6.1 GHz Triple Polarizations MIMO Base Station Antenna, 90**



The Triple Polarization Sector antenna provides coverage of 4.9-6.1 GHz frequency band in a single antenna radome.

- light weight and durable construction
- 3 Ports: Dual Slant ( $\pm 45^\circ$ ) and Vertical Polarization
- UV protected radome made of plastic
- specially designed for MIMO applications for optimal decorrelation

<b>Specifications:</b>	
<b>Electrical</b>	
<b>Frequency range</b> <b>GAIN : Vertical Pol.</b> <b>          Dual Slant Pol.</b> <b>VSWR, max.</b> <b>Polarization</b> <b>3 dB Beam-Width-Azimuth, typ.</b> <b>3 dB Beam-Width-Elevation, typ.</b> <b>Front to Back Ratio, min.</b> <b>Port to Port Isolation, min.</b> <b>Input power, max</b> <b>Input Impedance</b> <b>Lightning Protection</b>	<b>4.9- 6.1 GHz</b> <b>16 dBi</b> <b>16 dBi</b> <b>1.7 : 1</b> <b>Dual Slant <math>\pm 45^\circ</math> and Vertical</b> <b>Dual Slant : <math>90^\circ</math> ; V- Pol <math>90^\circ</math></b> <b>Dual Slant : <math>8^\circ</math> ; V- Pol <math>8^\circ</math></b> <b>-30 dB</b> <b>-30 dB</b> <b>10 Watt</b> <b>50 Ohm</b> <b>DC Grounded</b>
<b>Mechanical</b>	
<b>Dimensions (HxWxD)</b> <b>Connector</b> <b>Weight</b> <b>Mounting</b> <b>Radome</b> <b>Back Plane</b>	<b>370 x 370 x 40 mm (14.5" x14.5" x1.6")</b> <b>3 x N-Type Female</b> <b>2.1 Kg</b> <b>MNT-22</b> <b>UV Protected Polycarbonate</b> <b>Aluminum protected through chemical passivation</b>
<b>Environmental</b>	
<b>Operating Temperature Range</b> <b>Vibration</b> <b>Wind Load</b> <b>Flammability</b> <b>Water Proofing</b> <b>Humidity</b> <b>Salt Fog</b>	<b>- 40°C to + 65°C</b> <b>According to IEC 60721-3-4</b> <b>200 Km/h (Survival)</b> <b>UL94</b> <b>IP-67</b> <b>ETS 300 019-1-4,EN 302 085 (Annex A.1.1)</b> <b>According to IEC 68-2-11</b>

AS90-050-MIMO-16-T 4.9–6.1 GHz Triple Polarizations MIMO Base Station Antenna, 90

Radiations Patterns	
Frequency	5500 MHz
Gain, typ.	16 dBi

Vertical Polarization

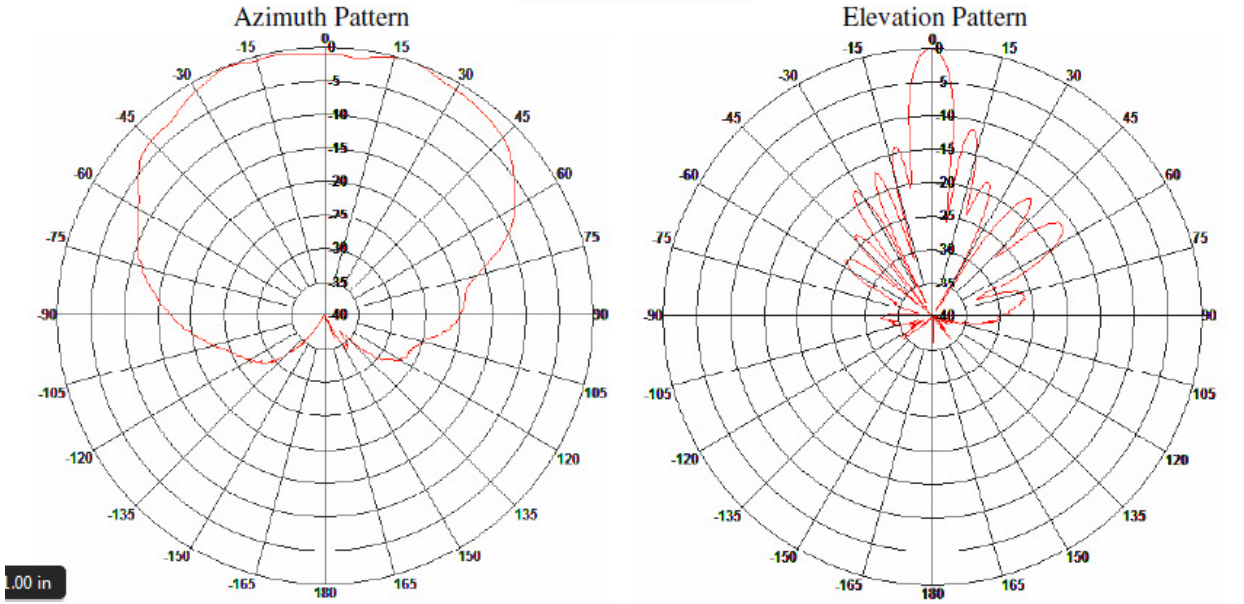

Dual Slant  $\pm 45^\circ$  Polarization

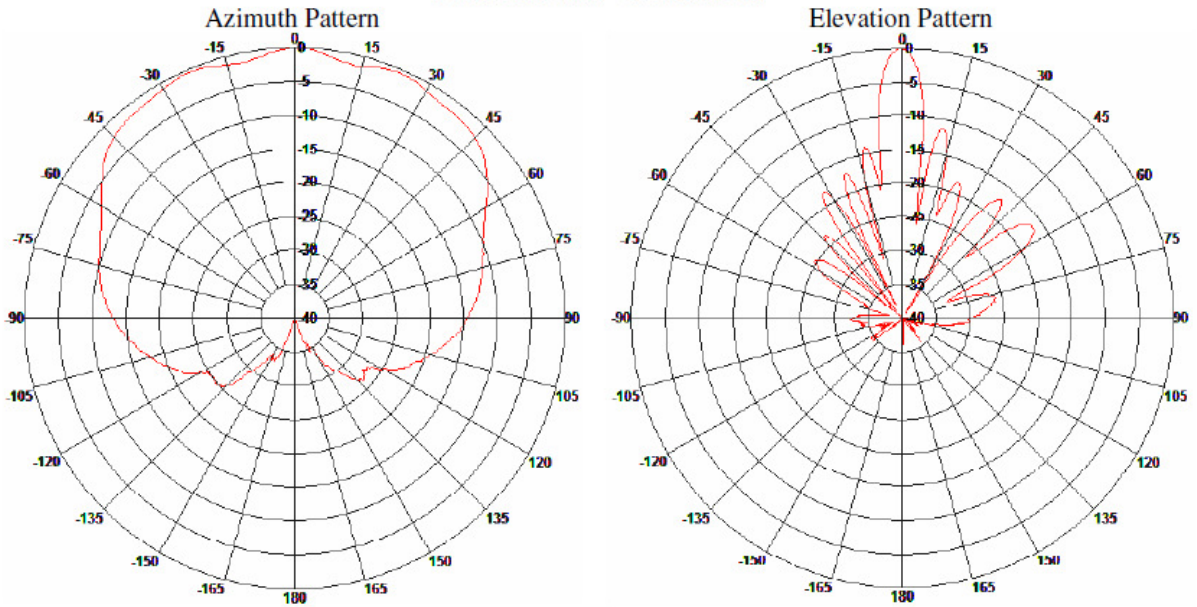

REV	DATE	DESCRIPTION
X1	6/24-2005	New Issue
X2	7/4-2005	Modify all

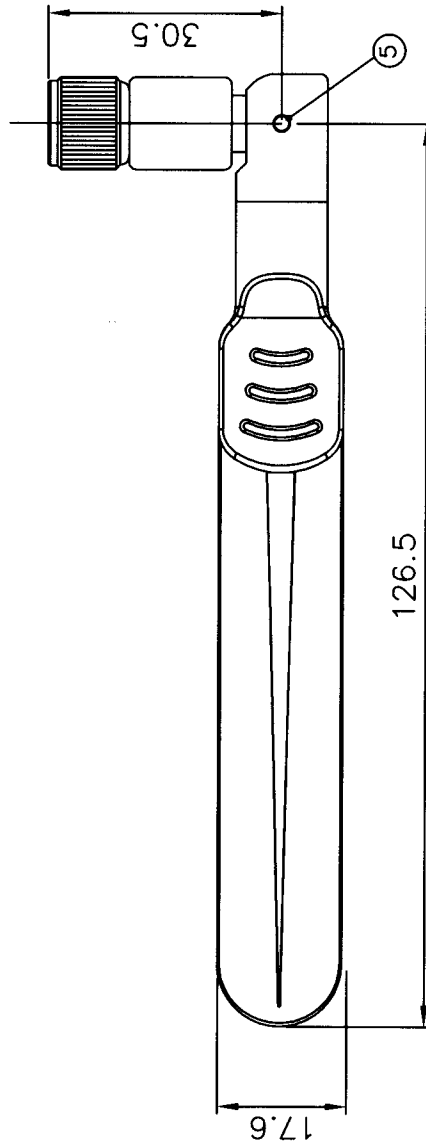
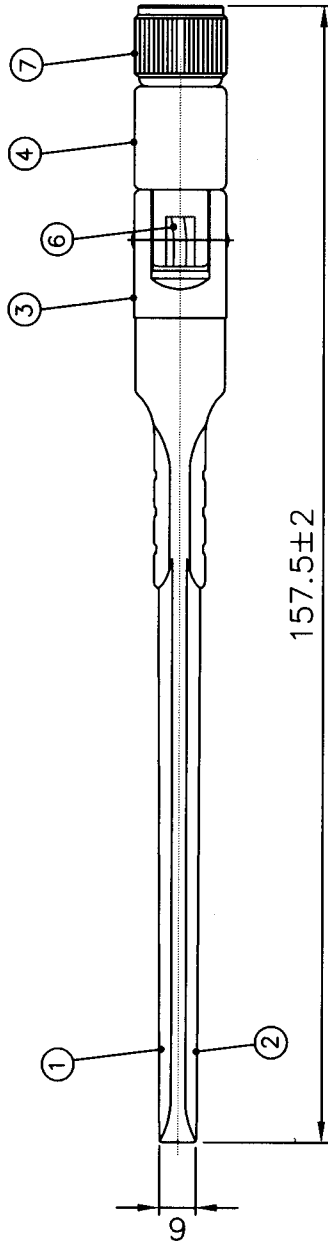

PE Bag  
Shrink Line

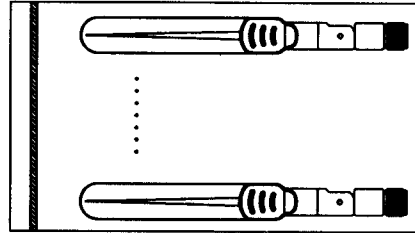

Packing : 10 pcs/bag

7	Connector	SMA Plug Straight Reverse	1	REMARK
6	Cable	RG-178 Cable	1	
5	Rivet	POM ; Black	1	
4	Antenna Base	PBT Color : Black	1	
3	Antenna Base	PC+ABS , Color : Black	1	
2	Antenna Housing(S)	PC+ABS , Color : Black	1	
1	Antenna Housing(M)	PC+ABS , Color : Black	1	
NO	DESCRIPTION		QTY	REMARK

CUSTOMER:	Fire tide
PART NO :	
PARTNAME:	RF Antenna Assembly
W.Y/PNO :	C812-510012-A
REV	UNIT FILE :
X2	m/m SHEET :
	1/1

CUSTOMER'S SIGNATURE

APPROVED  
CHECKED  
DRAWING

**Wha Yu**  
**INDUSTRIAL CO.,LTD.**  
**講裕實業股份有限公司**

THIS DRAWING, AND ITS INHERENT DESIGN CONCEPTS, ARE THE PROPERTY OF WHA YU AND AS SUCH MAY NOT BE COPIED, REPRODUCED, OR GIVEN TO THIRD PARTIES WITHOUT THE WRITTEN CONSENT OF WHA YU.

**RF Antenna Assembly**  
**P/NO :C812-510012-A SPEC : 5GHz**

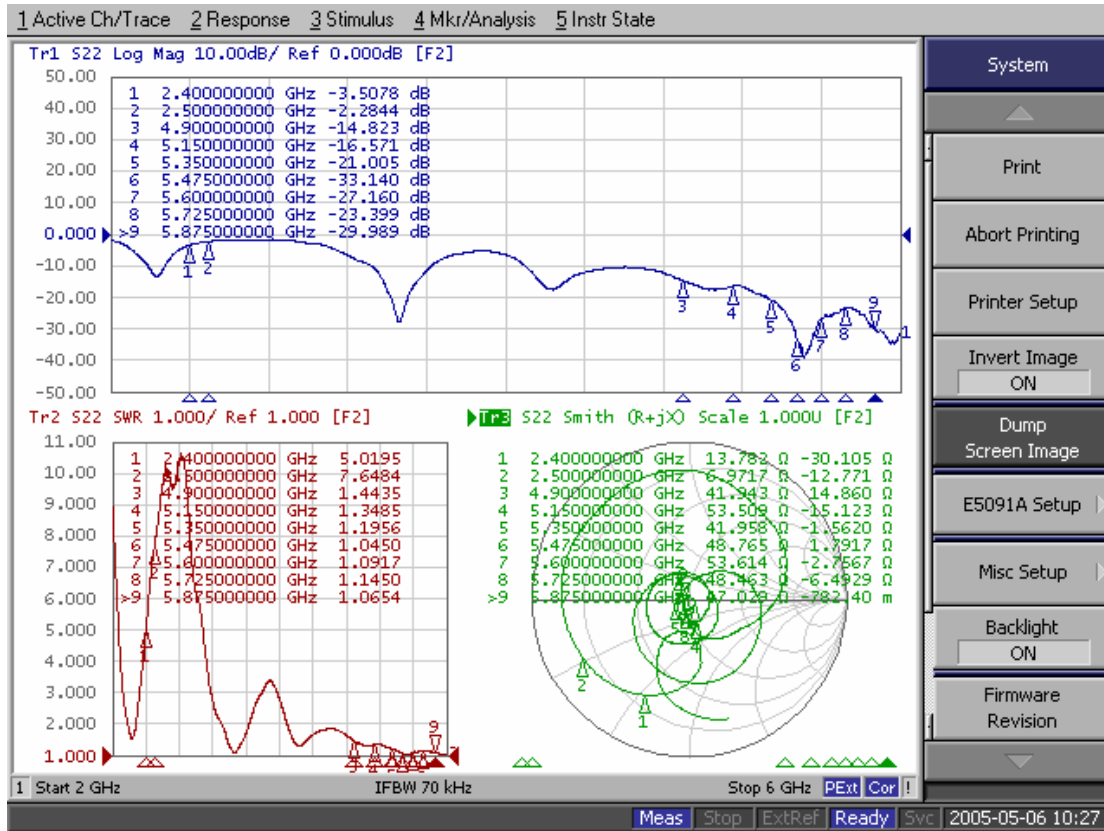



Far-field amplitude of C812-510012-A.nsi

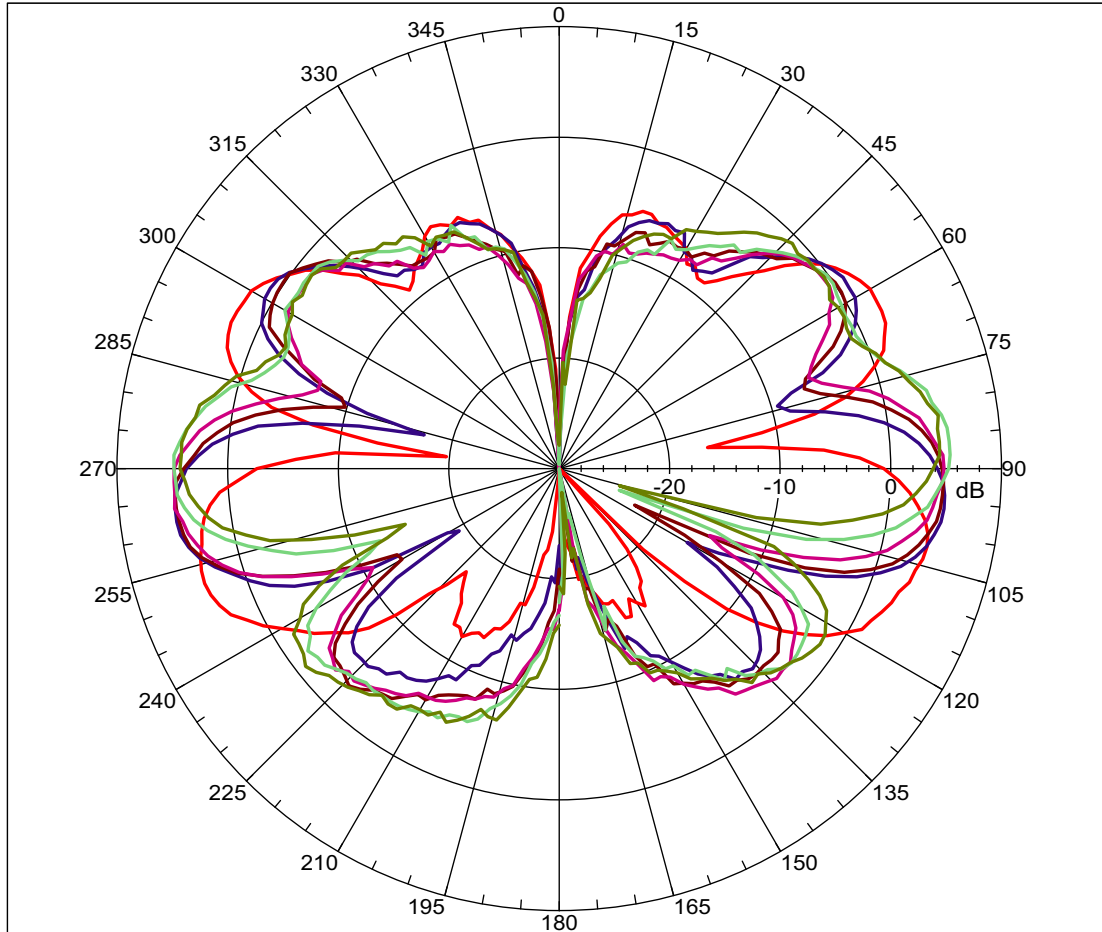
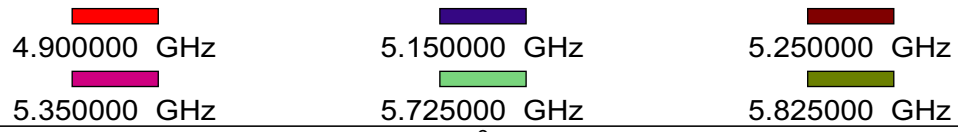



### Far-field amplitude of C812-510012-A.nsi

4.900000 GHz      5.150000 GHz      5.250000 GHz  
5.350000 GHz      5.725000 GHz      5.825000 GHz

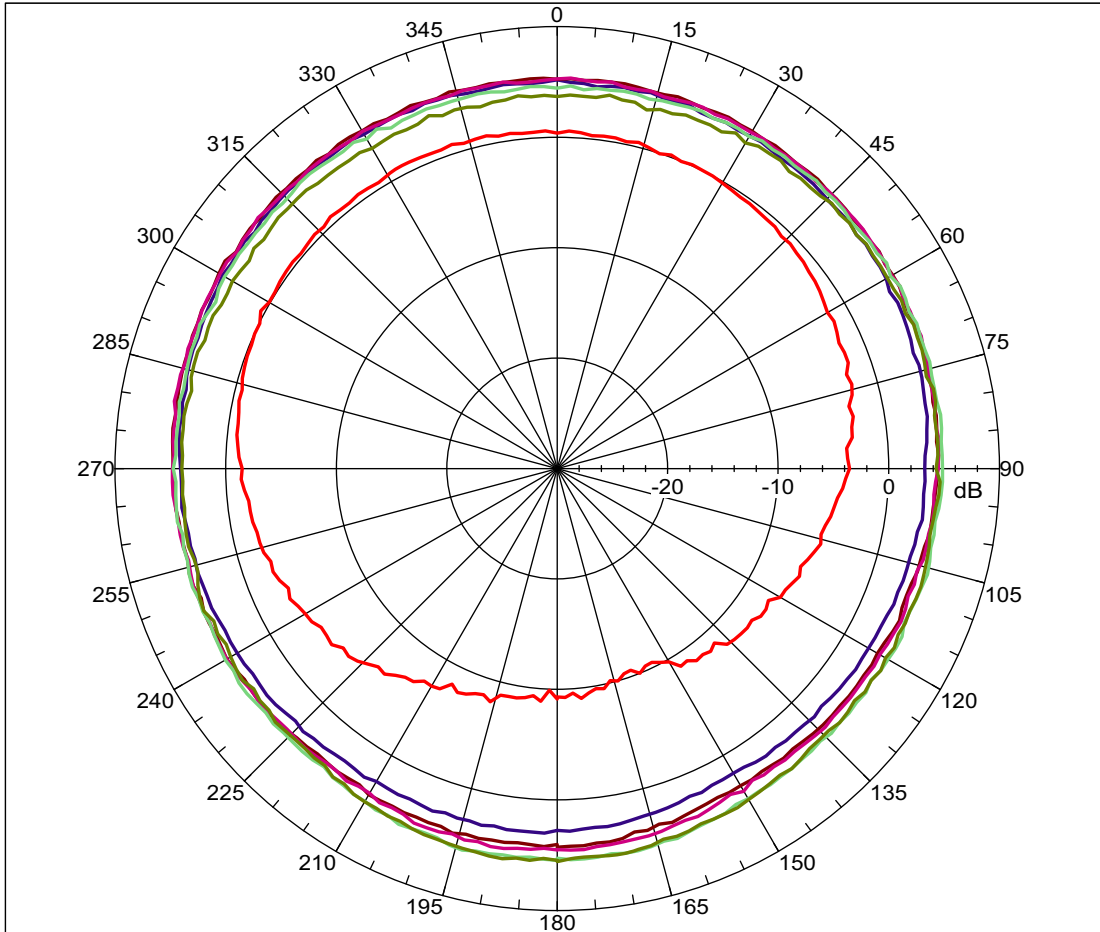

**4.9 - 5.875 GHz MIMO Omni – Directional Base Station Antenna**  
**Mars P/N: MA-W055-MIMONHFT9 Firetide P/N: AO-050-MIMO-9**



**Specifications:**

<b>Electrical</b>	
Frequency range	4.9 - 5.875 GHz
GAIN, typ.	3 x 9 dBi
VSWR, max.	2 : 1
Polarization	Linear, Vertical
3 dB Beam-Width, H-Plane, typ.	Omni - Directional
3 dB Beam-Width, E-Plane, typ.	10°
Input power, max	50 Watt
Input Impedance	50 Ohm
<b>Mechanical</b>	
Dimensions (HxDia.)	330 x 200 mm
Weight	600 gr
Connector	3 x N-Type, Female
Radome	UV Protected , Plastic
Mount	Provision for Fire Tide MIMO
<b>Environmental</b>	
Operating Temperature Range	- 40°C to + 65°C
Vibration	According to IEC 60721-3-4
Wind Load	200 km/h (survival)
Flammability	UL94
Water Proofing	IP-65
Humidity	ETS 300 019-1-4, EN 302 085 (annex A.1.1)
Salt Fog	According to IEC 68-2-11
Ice and Snow	25mm radial (survival)

Specifications subject to change without notice