



MET Laboratories, Inc. *Safety Certification - EMI - Telecom Environmental Simulation*

914 WEST PATAPSCO AVENUE • BALTIMORE, MARYLAND 21230-3432 • PHONE (410) 354-3300 • FAX (410) 354-3313

33439 WESTERN AVENUE • UNION CITY, CALIFORNIA 94587 • PHONE (510) 489-6300 • FAX (510) 489-6372

3162 BELICK STREET • SANTA CLARA, CALIFORNIA 95054 • PHONE (408) 748-3585 • FAX (510) 489-6372

January 17, 2011

Firetide, Inc.
16795 Lark Ave. Suite 200
Los Gatos, CA 95032

Dear Steve Gu,

Enclosed is the EMC Wireless test report for compliance testing of the Firetide, Inc., Firetide Indoor MIMO Access Points, Model 5100 as tested to the requirements of Title 47 of the CFR, Ch. 1 (10-1-06 ed.), Part 15, Subpart B, ICES-003, Issue 4 February 2004 for a Class A Digital Device and FCC Part 15 Subpart C, RSS-210, Issue 7, June 2007 for Intentional Radiators.

Thank you for using the services of MET Laboratories, Inc. If you have any questions regarding these results or if MET can be of further service to you, please feel free to contact me.

Sincerely yours,
MET LABORATORIES, INC.

Jennifer Warnell
Documentation Department

Reference: (\Firetide, Inc.\EMCS82555A-FCC247 Rev. 1)

Certificates and reports shall not be reproduced except in full, without the written permission of MET Laboratories, Inc.

Electromagnetic Compatibility Criteria Test Report

for the

**Firetide, Inc.
Firetide Indoor MIMO Access Points, Model 5100**

Tested under
the FCC Certification Rules
contained in
Title 47 of the CFR, Parts 15 Subpart B & ICES-003
for Class A Digital Devices
&
15.247 Subpart C & RSS-210, Issue 7, June 2007
for Intentional Radiators

MET Report: EMCS82555A-FCC247 Rev. 1

January 17, 2011

Prepared For:

**Firetide, Inc.
16795 Lark Ave. Suite 200
Los Gatos, CA 95032**

Prepared By:
MET Laboratories, Inc.
914 W. Patapsco Ave
Baltimore, MD 21230

Electromagnetic Compatibility Criteria Test Report

for the

Firetide, Inc.
Firetide Indoor MIMO Access Points, Model 5100

Tested under
the FCC Certification Rules
contained in
Title 47 of the CFR, Parts 15 Subpart B & ICES-003
for Class A Digital Devices
&
15.247 Subpart C & RSS-210, Issue 7, June 2007
for Intentional Radiators



Kenshi Chung, Project Engineer
Electromagnetic Compatibility Lab



Jennifer Warnell
Documentation Department

Engineering Statement: The measurements shown in this report were made in accordance with the procedures indicated, and the emissions from this equipment were found to be within the limits applicable. I assume full responsibility for the accuracy and completeness of these measurements, and for the qualifications of all persons taking them. It is further stated that upon the basis of the measurements made, the equipment tested is capable of operation in accordance with the requirements of the FCC Rules Parts 15B, 15.247 and Industry Canada standards ICES-003, Issue 4 February 2004, RSS-210, Issue 7, June 2007 under normal use and maintenance.



Shawn McMillen,
Wireless Manager, Electromagnetic Compatibility Lab

Report Status Sheet

Revision	Report Date	Reason for Revision
∅	October 29, 2010	Initial Issue.
1	January 17, 2011	Revised to reflect engineer corrections.

Table of Contents

I.	Executive Summary	1
	A. Purpose of Test	2
	B. Executive Summary	2
II.	Equipment Configuration	3
	A. Overview.....	4
	B. References.....	5
	C. Test Site	5
	D. Description of Test Sample.....	6
	E. Equipment Configuration.....	8
	F. Support Equipment	8
	G. Ports and Cabling Information.....	8
	H. Mode of Operation.....	9
	I. Method of Monitoring EUT Operation	9
	J. Modifications	9
	a) Modifications to EUT.....	9
	b) Modifications to Test Standard.....	9
	K. Disposition of EUT.....	9
III.	Electromagnetic Compatibility Criteria for Unintentional Radiators	10
	§ 15.107(a) Conducted Emissions Limits.....	11
	§ 15.109(a) Radiated Emissions Limits.....	18
IV.	Electromagnetic Compatibility Criteria for Intentional Radiators.....	26
	§ 15.203 Antenna Requirement	27
	§ 15.207(a) Conducted Emissions Limits.....	28
	§ 15.247(a) 6 dB and 99% Bandwidth.....	29
	§ 15.247(b) Peak Power Output and RF Exposure	30
	§ 15.247(d) Radiated Spurious Emissions Requirements and Band Edge	31
	RSS-GEN Receiver Spurious Emissions.....	33
	§ 15.247(d) RF Conducted Spurious Emissions Requirements and Band Edge.....	34
	§ 15.247(e) Peak Power Spectral Density	35
V.	Test Equipment	36
VI.	Certification & User's Manual Information.....	38
	A. Certification Information	39
	B. Label and User's Manual Information	43
VII.	ICES-003 Procedural & Labeling Requirements.....	45

List of Tables

Table 1. Executive Summary of EMC Part 15.247 Compliance Testing	2
Table 2. EUT Summary Table.....	4
Table 3. References	5
Table 4. Equipment Configuration	8
Table 5. Support Equipment.....	8
Table 6. Ports and Cabling Information	8
Table 7. Conducted Limits for Radio Frequency Devices calculated from FCC Part 15 Subsections 15.107(a) (b) and 15.207(a)	11
Table 8. Conducted Emissions - Voltage, AC Power, Phase Line (120 VAC, 60 Hz), FSP040-DGAA5	12
Table 9. Conducted Emissions - Voltage, AC Power, Neutral Line (120 VAC, 60 Hz), FSP040-DGAA5.....	13
Table 10. Conducted Emissions - Voltage, AC Power, Phase Line (120 VAC, 60 Hz), PoE30U-560.....	14
Table 11. Conducted Emissions - Voltage, AC Power, Neutral Line (120 VAC, 60 Hz), PoE30U-560	15
Table 12. Radiated Emissions Limits calculated from FCC Part 15, §15.109 (a) (b)	18
Table 13. Radiated Emissions Limits, Test Results, 30 MHz – 1 GHz, FCC Limits, FSP040-DGAA5.....	19
Table 14. Radiated Emissions Limits, Test Results, 30 MHz – 1 GHz, FCC Limits, PoE30U-560	21
Table 15. Radiated Emissions Limits, Test Results, ICES-003 Limits, FSP040-DGAA5.....	23
Table 16. Radiated Emissions Limits, Test Results, ICES-003 Limits PoE30U-560	24
Table 17. Conducted Limits for Intentional Radiators from FCC Part 15 § 15.207(a)	28
Table 18. Output Power Requirements from §15.247.....	30
Table 19. Restricted Bands of Operation.....	31
Table 20. Radiated Emissions Limits Calculated from FCC Part 15, § 15.209 (a)	32
Table 21. Spurious Emission Limits for Receivers	33
Table 22. Test Equipment List	37

List of Plots

Plot 1. Conducted Emission, Phase Line Plot, FSP040-DGAA5	12
Plot 2. Conducted Emission, Neutral Line Plot, FSP040-DGAA5.....	13
Plot 3. Conducted Emission, Phase Line Plot, PoE30U-560.....	14
Plot 4. Conducted Emission, Neutral Line Plot, PoE30U-560.....	15
Plot 5. Radiated Emissions, 30 MHz - 1 GHz, FCC Limits, FSP040-DGAA5.....	19
Plot 6. Radiated Emissions, 1 GHz – 6 GHz, FCC Limits, FSP040-DGAA5.....	20
Plot 7. Radiated Emissions, 30 MHz - 1 GHz, FCC Limits, PoE30U-560	21
Plot 8. Radiated Emissions, 1 GHz – 10 GHz, FCC Limits, PoE30U-560	22
Plot 9. Radiated Emissions, ICES-003 Limits, FSP040-DGAA5	23
Plot 10. Radiated Emissions, ICES-003 Limits PoE30U-560.....	24

List of Figures

Figure 1. Setup Block Diagram.....	7
------------------------------------	---

List of Photographs

Photograph 1. Firetide, Inc. Firetide Indoor MIMO Access Points, Model 5100	6
Photograph 2. Conducted Emissions, FSP040-DGAA5, Test Setup 1.....	16
Photograph 3. Conducted Emissions, FSP040-DGAA5, Test Setup 2.....	16
Photograph 4. Conducted Emissions, PoE30U-560, Test Setup 1	17
Photograph 5. Conducted Emissions, PoE30U-560, Test Setup 2	17
Photograph 6. Radiated Emission, Test Setup.....	25

List of Terms and Abbreviations

AC	Alternating Current
ACF	Antenna Correction Factor
Cal	Calibration
<i>d</i>	Measurement Distance
dB	Decibels
dB μ A	Decibels above one microamp
dB μ V	Decibels above one microvolt
dB μ A/m	Decibels above one microamp per meter
dB μ V/m	Decibels above one microvolt per meter
DC	Direct Current
E	Electric Field
DSL	Digital Subscriber Line
ESD	Electrostatic Discharge
EUT	Equipment Under Test
<i>f</i>	Frequency
FCC	Federal Communications Commission
GRP	Ground Reference Plane
H	Magnetic Field
HCP	Horizontal Coupling Plane
Hz	Hertz
IEC	International Electrotechnical Commission
kHz	kilohertz
kPa	kilopascal
kV	kilovolt
LISN	Line Impedance Stabilization Network
MHz	Megahertz
μ H	microhenry
μ	microfarad
μ s	microseconds
NEBS	Network Equipment-Building System
PRF	Pulse Repetition Frequency
RF	Radio Frequency
RMS	Root-Mean-Square
TWT	Traveling Wave Tube
V/m	Volts per meter
VCP	Vertical Coupling Plane

I. Executive Summary

A. Purpose of Test

An EMC evaluation was performed to determine compliance of the Firetide, Inc. Firetide Indoor MIMO Access Points, Model 5100, with the requirements of Part 15, §15.247. All references are to the most current version of Title 47 of the Code of Federal Regulations in effect. In accordance with §2.1033, the following data is presented in support of the Certification of the Firetide Indoor MIMO Access Points, Model 5100. Firetide, Inc. should retain a copy of this document which should be kept on file for at least two years after the manufacturing of the Firetide Indoor MIMO Access Points, Model 5100, has been **permanently** discontinued.

B. Executive Summary

The following tests were conducted on a sample of the equipment for the purpose of demonstrating compliance with Part 15, §15.247, in accordance with Firetide, Inc., purchase order number 2747. All tests were conducted using measurement procedure ANSI C63.4-2003.

FCC Reference 47 CFR Part 15.247:2005	IC Reference RSS-210 Issue 7: 2007	Description	Compliance
47 CFR Part 15.107 (a)	ICES-003 Issue 4 February 2004	Conducted Emission Limits for a Class A Digital Device	Compliant
47 CFR Part 15.109 (a)	ICES-003 Issue 4 February 2004	Radiated Emission Limits for a Class A Digital Device	Compliant
Title 47 of the CFR, Part 15 §15.203	N/A	Antenna Requirement	Compliant
Title 47 of the CFR, Part 15 §15.207(a)	RSS-210(7.2.2)	Conducted Emission Voltage	Refer to FCC ID: NKR- DNMA83/IC: 4441A-DNMA83
Title 47 of the CFR, Part 15 §15.247(a)(1)	RSS-210(A8.1)	Occupied Bandwidth	Refer to FCC ID: NKR- DNMA83/IC: 4441A-DNMA83
Title 47 of the CFR, Part 15 §15.247(b)	RSS-210(A8.4)	RF Output Power	Refer to FCC ID: NKR- DNMA83/IC: 4441A-DNMA83
Title 47 of the CFR, Part 15 §15.209, §15.247(d)	RSS-210(A8.5)	Radiated Spurious Emissions	Refer to FCC ID: NKR- DNMA83/IC: 4441A-DNMA83
Title 47 of the CFR, Part 15 §15.205	RSS-210(A8.5)	Emissions at Restricted Band	Refer to FCC ID: NKR- DNMA83/IC: 4441A-DNMA83
Title 47 of the CFR, Part 15 §15.209, §15.247(d)	RSS-210(A8.5)	Conducted Spurious Emissions	Refer to FCC ID: NKR- DNMA83/IC: 4441A-DNMA83
Title 47 of the CFR, Part 15; §15.247(e)	RSS-210(A8.3)	Power Spectral Density	Refer to FCC ID: NKR- DNMA83/IC: 4441A-DNMA83
Title 47 of the CFR, Part 15 §15.247(i)	RSS-Gen(5.5)	Maximum Permissible Exposure	Refer to FCC ID: NKR- DNMA83/IC: 4441A-DNMA83
N/A	RSS-Gen(4.8)	Receiver Spurious Emissions	Refer to FCC ID: NKR- DNMA83/IC: 4441A-DNMA83

Table 1. Executive Summary of EMC Part 15.247 Compliance Testing

II. Equipment Configuration

A. Overview

MET Laboratories, Inc. was contracted by Firetide, Inc. to perform testing on the Firetide Indoor MIMO Access Points, Model 5100, under Firetide, Inc.'s purchase order number 2747.

This document describes the test setups, test methods, required test equipment, and the test limit criteria used to perform compliance testing of the Firetide, Inc., Firetide Indoor MIMO Access Points, Model 5100.

The results obtained relate only to the item(s) tested.

Model(s) Tested:	Firetide Indoor MIMO Access Points, Model 5100	
Model(s) Covered:	Firetide Indoor MIMO Access Points, Model 5100	
EUT Specifications:	Primary Power: 120 VAC, 60 Hz	
	FCC ID: REP-5100-1 IC: 4988A-5100	
	Type of Modulations:	OFDM
	Equipment Code:	DTS
	Peak RF Output Power:	0.2615 (2.4 GHz) 0.6029 (5.8 GHz)
	EUT Frequency Ranges:	2412-2462 MHz 5745-5825 MHz
Analysis:	The results obtained relate only to the item(s) tested.	
Environmental Test Conditions:	Temperature: 15-35° C	
	Relative Humidity: 30-60%	
	Barometric Pressure: 860-1060 mbar	
Evaluated by:	Kenshi Chung	
Report Date(s):	January 17, 2011	

Table 2. EUT Summary Table

B. References

CFR 47, Part 15, Subpart C	Federal Communication Commission, Code of Federal Regulations, Title 47, Part 15: General Rules and Regulations, Allocation, Assignment, and Use of Radio Frequencies
RSS-210, Issue 7, June 2007	Low-power Licence-exempt Radiocommunications Devices (All Frequency Bands): Category I Equipment
CFR 47, Part 15, Subpart B	Electromagnetic Compatibility: Criteria for Radio Frequency Devices
ICES-003, Issue 4 February 2004	Electromagnetic Compatibility: Criteria for Radio Frequency Devices
ANSI C63.4:2003	Methods and Measurements of Radio-Noise Emissions from Low-Voltage Electrical And Electronic Equipment in the Range of 9 kHz to 40 GHz
ANSI/NCSL Z540-1-1994	Calibration Laboratories and Measuring and Test Equipment – General Requirements
ANSI/ISO/IEC 17025:2000	General Requirements for the Competence of Testing and Calibration Laboratories
ANSI C63.10-2009	American National Standard for Testing Unlicensed Wireless Devices

Table 3. References

C. Test Site

All testing was performed at MET Laboratories, Inc., 914 W. Patapsco Ave., Baltimore, MD 21230. All equipment used in making physical determinations is accurate and bears recent traceability to the National Institute of Standards and Technology.

Radiated Emissions measurements were performed in a 10 meter semi-anechoic chamber (equivalent to an Open Area Test Site). In accordance with §2.948(a)(3), a complete site description is contained at MET Laboratories.

D. Description of Test Sample

The Firetide, Inc. Firetide Indoor MIMO Access Points, Model 5100, Equipment Under Test (EUT), utilizes Wistron DNMA-83 mini PCI radios.



Photograph 1. Firetide, Inc. Firetide Indoor MIMO Access Points, Model 5100

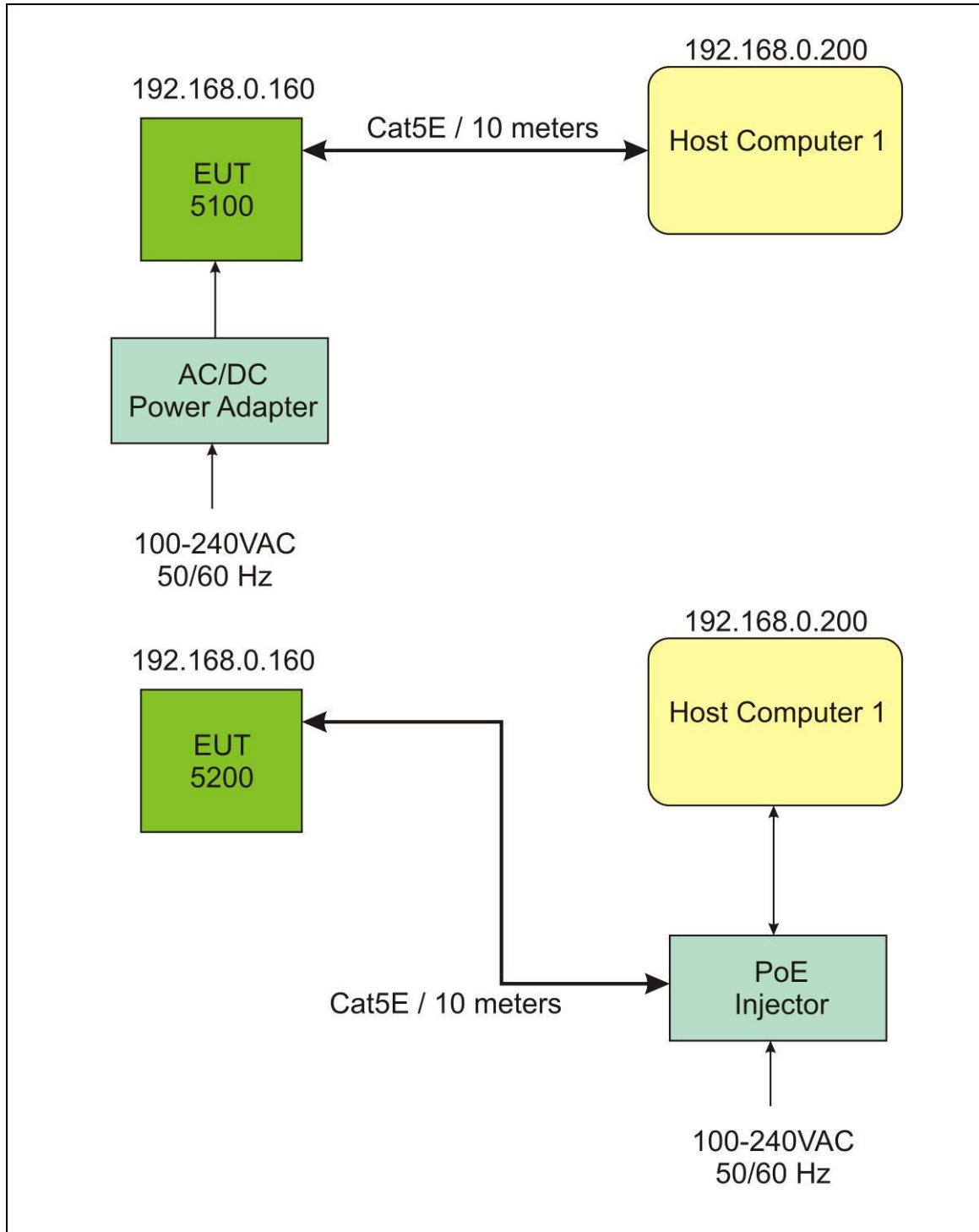

Figure 1. Setup Block Diagram

E. Equipment Configuration

The EUT was set up as outlined in **Error! Reference source not found.**, Block Diagram of Test Setup. All cards, racks, etc., incorporated as part of the EUT is included in the following list.

Ref. ID	Name / Description	Model Number	Part Number	Serial Number	Rev. #
A	Firetide Indoor AP	5100	5100	W4P071034500416	1
B	AC/DC Power Adapter	FSP040-DGAA5	9NA0402400	H00000043	NA
C	PoE Injector (PhiHong)	PoE30U-560	PoE30U-560	P71300181A1	NA

Table 4. Equipment Configuration

F. Support Equipment

Support equipment necessary for the operation and testing of the EUT is included in the following list.

Ref. ID	Name / Description	Manufacturer	Model Number	Customer Supplied Calibration Data
D	Laptop computer	Dell	vostro 1000	N/A

Table 5. Support Equipment

G. Ports and Cabling Information

Ref. ID	Port name on EUT	Cable Description or reason for no cable	Qty.	Length (m)	Shielded (Y/N)	Termination Box ID & Port Name
1	DC Power	DC power input from SELV	1	1	N	N/A
2	Ethernet	IP connection to host computer	1	10	N	N/A

Table 6. Ports and Cabling Information

H. Mode of Operation

Operation can be monitored using by pinging the EUT or running ART.

I. Method of Monitoring EUT Operation

IP connectivity is maintained with the EUT. If IP connectivity is lost, EUT connectivity shall be re-established upon power up or re-boot.

J. Modifications

a) Modifications to EUT

No modifications were made to the EUT.

b) Modifications to Test Standard

No modifications were made to the test standard.

K. Disposition of EUT

The test sample including all support equipment submitted to the Electro-Magnetic Compatibility Lab for testing was returned to Firetide, Inc. upon completion of testing.

III. Electromagnetic Compatibility Criteria for Unintentional Radiators

Electromagnetic Compatibility Criteria

§ 15.107 Conducted Emissions Limits

Test Requirement(s): **15.107 (a)** Except for Class A digital devices, for equipment that is designed to be connected to the public utility (AC) power line, the radio frequency voltage that is conducted back onto the AC power line on any frequency or frequencies within the band 150 kHz to 30 MHz shall not exceed the limits in Table 7. Compliance with this provision shall be based on the measurement of the radio frequency voltage between each power line and ground at the power terminals.

15.107 (b) For a Class A digital device that is designed to be connected to the public utility (AC) power line, the radio frequency voltage that is conducted back onto the AC power line on any frequency or frequencies within the band 150 kHz to 30 MHz shall not exceed the limits in Table 7. Compliance with this provision shall be based on the measurement of the radio frequency voltage between each power line and ground at the power terminals. The lower limit applies at the band edges.

15.207(a), Except as shown in paragraphs (b) and (c) of this section*, charging, AC adapters or battery eliminators the radio frequency voltage that is conducted back onto the AC power line on any frequency or frequencies, within the band 150 kHz to 30 MHz, shall not exceed the limits in the Table 7, as measured using a 50 μ H/50 ohms line impedance stabilization network (LISN). Compliance with the provisions of this paragraph shall be based on the measurement of the radio frequency voltage between each power line and ground at the power terminal. The lower limit applies at the boundary between the frequencies ranges.

Frequency range (MHz)	Class A Conducted Limits (dB μ V)		*Class B Conducted Limits (dB μ V)	
	Quasi-Peak	Average	Quasi-Peak	Average
* 0.15- 0.45	79	66	66 - 56	56 - 46
0.45 - 0.5	79	66	56	46
0.5 - 30	73	60	60	50

Note 1 — The lower limit shall apply at the transition frequencies.
 Note 2 — The limit decreases linearly with the logarithm if the frequency in the range 0.15 MHz to 0.5 MHz.
 * -- Limits per Subsection 15.207(a).

Table 7. Conducted Limits for Radio Frequency Devices calculated from FCC Part 15 Subsections 15.107(a) (b) and 15.207(a)

Test Results: The EUT was compliant with the Class A requirement(s) of this section. Measured emissions were below applicable limits.

Test Engineer(s): Kenshi Chung

Test Date(s): 08/17/10

Conducted Emissions - Voltage, AC Power, Phase Line (120 VAC, 60 Hz)

Line	Freq (MHz)	QP Amplitude	QP Limit	Delta	Pass	Average Amplitude	Average Limit	Delta	Pass	Notes
AC - Line	0.1550	47.91	79	-31.09	Pass	28.07	66	-37.93	Pass	Measured Emission was below applicable limits
AC - Line	0.4162	38.65	79	-40.35	Pass	29.87	66	-36.13	Pass	Measured Emission was below applicable limits
AC - Line	0.710	36.25	73	-36.75	Pass	30.74	60	-29.26	Pass	Measured Emission was below applicable limits
AC - Line	1.243	38.08	73	-34.92	Pass	32.55	60	-27.45	Pass	Measured Emission was below applicable limits
AC - Line	1.775	36.4	73	-36.6	Pass	30.85	60	-29.15	Pass	Measured Emission was below applicable limits
AC - Line	28.85	22.9	73	-50.1	Pass	14.92	60	-45.08	Pass	Measured Emission was below applicable limits

Table 8. Conducted Emissions - Voltage, AC Power, Phase Line (120 VAC, 60 Hz), FSP040-DGAA5

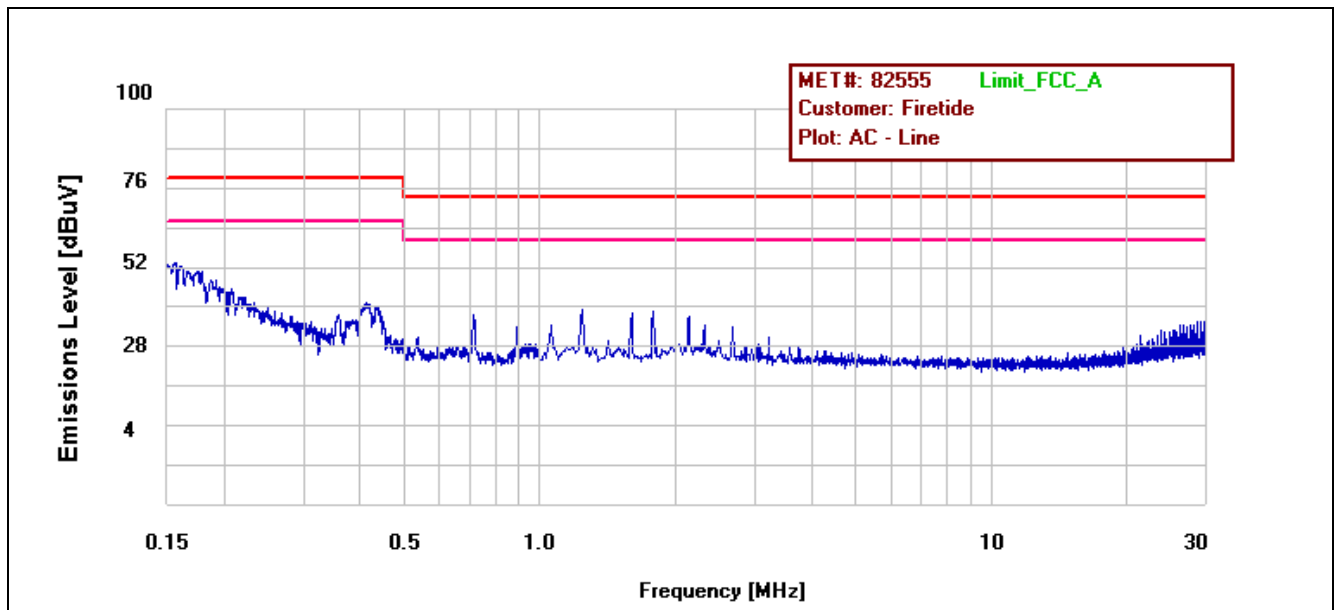

Plot 1. Conducted Emission, Phase Line Plot, FSP040-DGAA5

Conducted Emissions - Voltage, AC Power, Neutral Line (120 VAC, 60 Hz)

Line	Freq (MHz)	QP Amplitude	QP Limit	Delta	Pass	Average Amplitude	Average Limit	Delta	Pass	Notes
AC - Neutral	0.1503	48.23	79	-30.77	Pass	33.29	66	-32.71	Pass	Measured Emission was below applicable limits
AC - Neutral	0.4167	40.44	79	-38.56	Pass	36.21	66	-29.79	Pass	Measured Emission was below applicable limits
AC - Neutral	0.708	37.25	73	-35.75	Pass	35.74	60	-24.26	Pass	Measured Emission was below applicable limits
AC - Neutral	1.241	39.23	73	-33.77	Pass	38.1	60	-21.9	Pass	Measured Emission was below applicable limits
AC - Neutral	1.772	35.97	73	-37.03	Pass	34.35	60	-25.65	Pass	Measured Emission was below applicable limits
AC - Neutral	29.325	25.22	73	-47.78	Pass	18.79	60	-41.21	Pass	Measured Emission was below applicable limits

Table 9. Conducted Emissions - Voltage, AC Power, Neutral Line (120 VAC, 60 Hz), FSP040-DGAA5

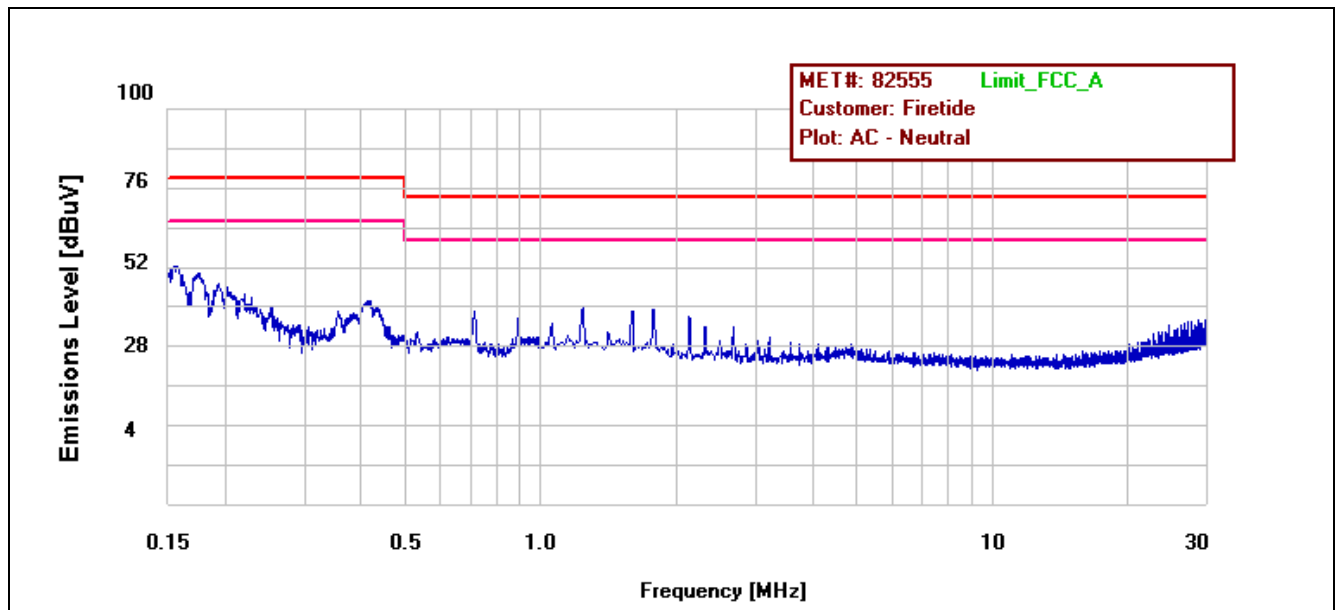

Plot 2. Conducted Emission, Neutral Line Plot, FSP040-DGAA5

Conducted Emissions - Voltage, AC Power, Phase Line (120 VAC, 60 Hz)

Line	Freq (MHz)	QP Amplitude	QP Limit	Delta	Pass	Average Amplitude	Average Limit	Delta	Pass	Notes
AC - Line	0.1867	38.09	79	-40.91	Pass	33.08	66	-32.92	Pass	Measured Emission was below applicable limits
AC - Line	0.2360	32.25	79	-46.75	Pass	26.9	66	-39.1	Pass	Measured Emission was below applicable limits
AC - Line	1.497	26.01	73	-46.99	Pass	20.09	60	-39.91	Pass	Measured Emission was below applicable limits
AC - Line	4.592	26.87	73	-46.13	Pass	20.41	60	-39.59	Pass	Measured Emission was below applicable limits
AC - Line	14.450	46.87	73	-26.13	Pass	40.56	60	-19.44	Pass	Measured Emission was below applicable limits

Table 10. Conducted Emissions - Voltage, AC Power, Phase Line (120 VAC, 60 Hz), PoE30U-560

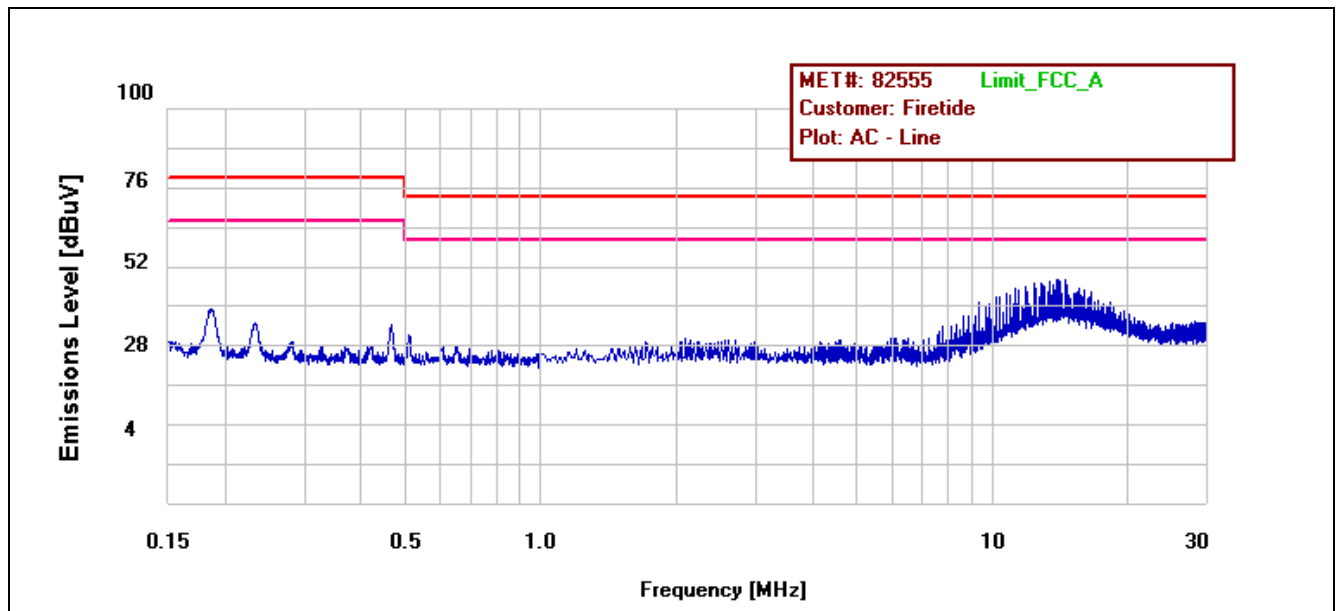

Plot 3. Conducted Emission, Phase Line Plot, PoE30U-560

Conducted Emissions - Voltage, AC Power, Neutral Line (120 VAC, 60 Hz)

Line	Freq (MHz)	QP Amplitude	QP Limit	Delta	Pass	Average Amplitude	Average Limit	Delta	Pass	Notes
AC - Neutral	0.1886	37.58	79	-41.42	Pass	36.53	66	-29.47	Pass	Measured Emission was below applicable limits
AC - Neutral	0.2352	32.94	79	-46.06	Pass	31.3	66	-34.7	Pass	Measured Emission was below applicable limits
AC - Neutral	1.0325	28.79	73	-44.21	Pass	25.82	60	-34.18	Pass	Measured Emission was below applicable limits
AC - Neutral	4.603	29.56	73	-43.44	Pass	27.05	60	-32.95	Pass	Measured Emission was below applicable limits
AC - Neutral	13.90	35.4	73	-37.6	Pass	29.24	60	-30.76	Pass	Measured Emission was below applicable limits

Table 11. Conducted Emissions - Voltage, AC Power, Neutral Line (120 VAC, 60 Hz), PoE30U-560

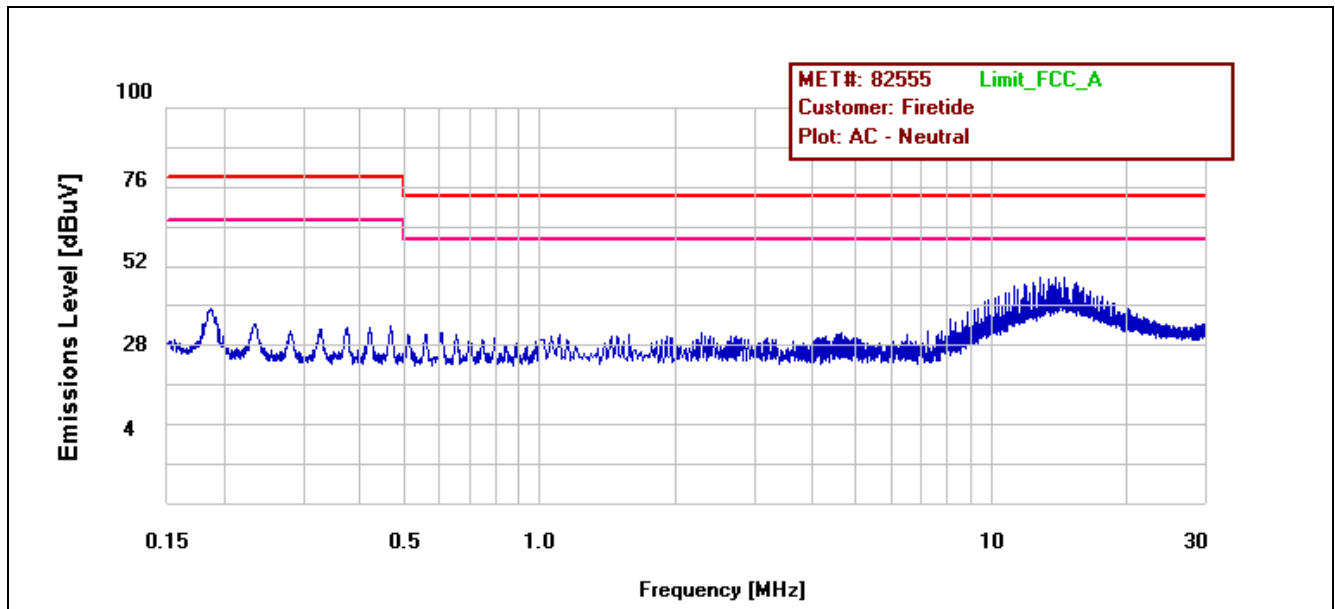

Plot 4. Conducted Emission, Neutral Line Plot, PoE30U-560

Conducted Emission Limits Test Setup



Photograph 2. Conducted Emissions, FSP040-DGAA5, Test Setup 1

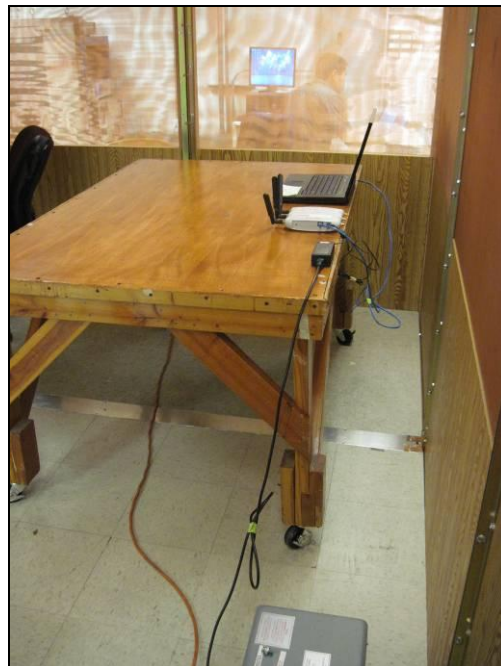

Photograph 3. Conducted Emissions, FSP040-DGAA5, Test Setup 2



Photograph 4. Conducted Emissions, PoE30U-560, Test Setup 1

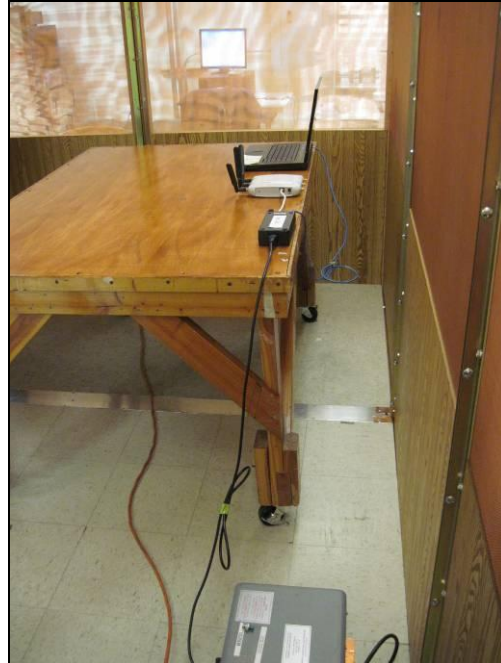

Photograph 5. Conducted Emissions, PoE30U-560, Test Setup 2

Radiated Emission Limits

§ 15.109 Radiated Emissions Limits

Test Requirement(s): **15.109 (a)** Except for Class A digital devices, the field strength of radiated emissions from unintentional radiators at a distance of 3 meters shall not exceed the Class B limits expressed in Table 12.

15.109 (b) The field strength of radiated emissions from a Class A digital device, as determined at a distance of 10 meters, shall not exceed the Class A limits expressed in Table 12.

Frequency (MHz)	Field Strength (dB μ V/m)	
	§15.109 (b), Class A Limit (dB μ V) @ 10m	§15.109 (a), Class B Limit (dB μ V) @ 3m
30 - 88	39.00	40.00
88 - 216	43.50	43.50
216 - 960	46.40	46.00
Above 960	49.50	54.00

Table 12. Radiated Emissions Limits calculated from FCC Part 15, §15.109 (a) (b)

Test Procedures: The EUT was placed on a non-metallic table, 80 cm above the ground plane inside a semi-anechoic chamber. The method of testing and test conditions of ANSI C63.4 were used. An antenna was located 10m from the EUT on an adjustable mast. A pre-scan was first performed in order to find prominent radiated emissions. For final emissions measurements at each frequency of interest, the EUT was rotated and the antenna height was varied between 1 m and 4 m in order to maximize the emission. Measurements in both horizontal and vertical polarities were made and the data was recorded. Unless otherwise specified, measurements were made using a quasi-peak detector with a 120 kHz bandwidth.

Test Results: The EUT was compliant with the Class A requirement(s) of this section. Measured emissions were below applicable limits.

Test Engineer(s): Anderson Soungpanya and Kenshi Chung

Test Date(s): 08/13/10 and 08/16/10

Radiated Emissions Limits Test Results, Class A

Frequency (MHz)	Antenna Polarity	EUT Azimuth (Degrees)	Antenna Height (cm)	Uncorrected Amplitude (dBuV)	ACF (dB/m)	Pre Amp Gain (dB)	CBL (dB)	DCF (dB)	Corrected Amplitude (dBuV)	Limit (dBuV)	Margin (dB)
374.998	H	179	293	53.309	15.2	40	3.198	0	31.707	46.4	-14.693
625.008	H	19	138	48.63	19.201	40	4.192	0	32.023	46.4	-14.377
749.972	H	290	115	50.359	19.301	40	4.561	0	34.221	46.4	-12.179
749.969	V	225	206	42.982	19.301	40	4.561	0	26.844	46.4	-19.556
749.972	V	82	271	45.349	19.301	40	4.561	0	29.211	46.4	-17.189
799.958	V	264	187	40.421	19.999	40	4.755	0	25.175	46.4	-21.225
225.802	V	51	100	51.718	9.848	40	2.381	0	23.947	46.4	-22.453
42.302	V	170	374	50.364	11.579	40	1.002	0	22.945	39	-16.055
226.24	H	0	400	56.209	9.874	40	2.371	0	28.454	46.4	-17.946
1133.4	V	18.40	108.9	74.71	24.791	51.978	0	-10.46	37.063	49.5	-12.437

Table 13. Radiated Emissions Limits, Test Results, 30 MHz – 1 GHz, FCC Limits, FSP040-DGAA5

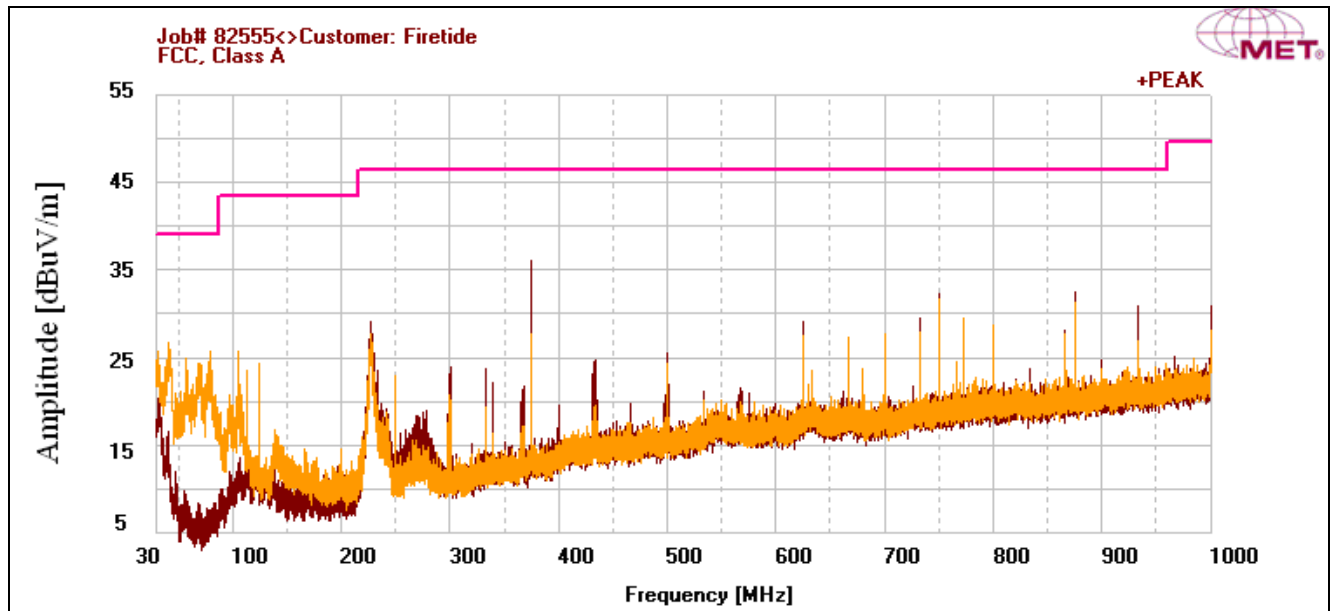

Plot 5. Radiated Emissions, 30 MHz - 1 GHz, FCC Limits, FSP040-DGAA5

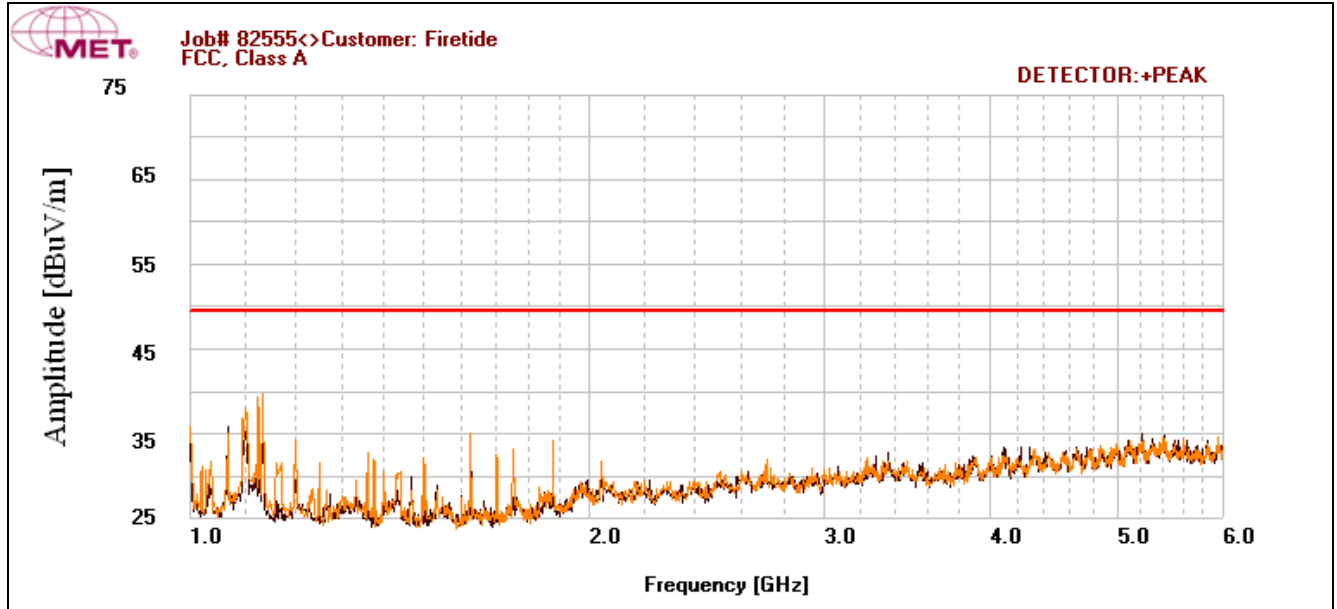

Plot 6. Radiated Emissions, 1 GHz – 6 GHz, FCC Limits, FSP040-DGAA5

Radiated Emissions Limits Test Results, Class A

Frequency (MHz)	Antenna Polarity	EUT Azimuth (Degrees)	Antenna Height (cm)	Uncorrected Amplitude (dBuV)	ACF (dB/m)	Pre Amp Gain (dB)	CBL (dB)	DCF (dB)	Corrected Amplitude (dBuV)	Limit (dBuV)	Margin (dB)
47.78	V	0	100	34.15	8.444	0	1.757	-10.46	33.891	39	-5.109
227.39	V	322	100	17.21	11.296	0	3.817	-10.46	21.863	46.4	-24.537
228.2	H	0	100	30.37	11.056	0	3.814	-10.46	34.78	46.4	-11.62
300	H	322	100	25.65	13.9	0	3.57	-10.46	32.66	46.4	-13.74
333.33	H	164	100	20.86	14.767	0	3.763	-10.46	28.93	46.4	-17.47
800	H	330	100	19.91	20.9	0	6.23	-10.46	26.164	54	-27.836
1125	V	360	100	78.15	27.485	76.893	7.882	-10.46	28.626	54	-25.374
1000	H	0	100	81.6	27.216	77.23	7.5	-10.46	23.614	54	-30.386
1125	H	0	100	75.6	27.485	76.893	7.882	-10.46	26.164	54	-27.836

Table 14. Radiated Emissions Limits, Test Results, 30 MHz – 1 GHz, FCC Limits, PoE30U-560

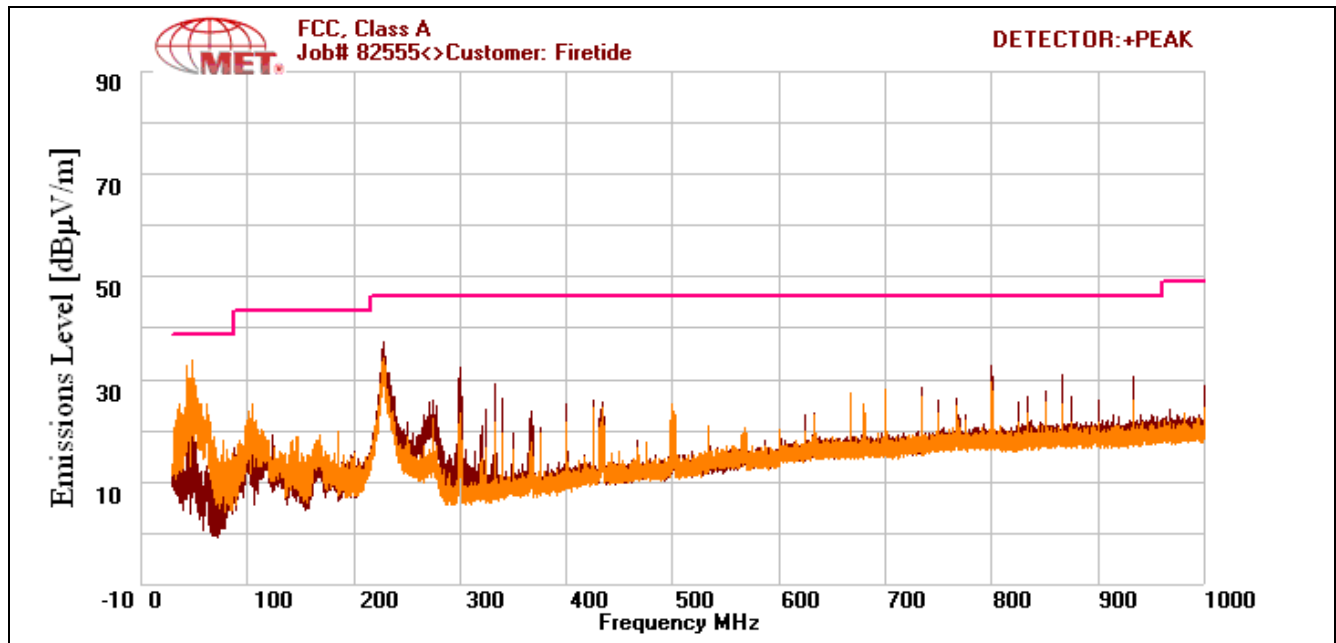

Plot 7. Radiated Emissions, 30 MHz - 1 GHz, FCC Limits, PoE30U-560

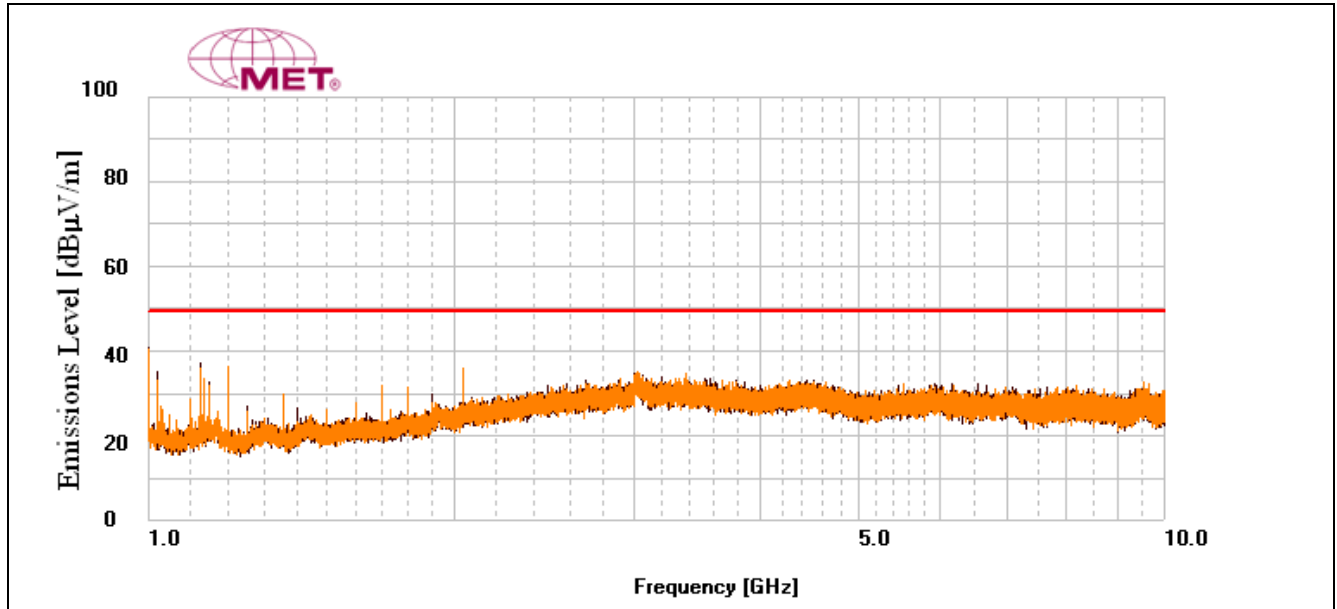

Plot 8. Radiated Emissions, 1 GHz – 10 GHz, FCC Limits, PoE30U-560

Radiated Emissions Limits Test Results, Class A

Frequency (MHz)	EUT Azimuth (Degrees)	Antenna Polarity (H/V)	Antenna HEIGHT (m)	Uncorrected Amplitude (dBuV)	Antenna Correction Factor (dB) (+)	Pre Amp Gain (dB)	Cable Loss (dB) (+)	Distance Correction Factor (dB) (-)	Corrected Amplitude (dBuV/m)	Limit (dBuV/m)	Margin (dB)
374.998	H	179	293	53.309	15.2	40	3.198	0	31.707	47	-15.293
625.008	H	19	138	48.63	19.201	40	4.192	0	32.023	47	-14.977
749.972	H	290	115	50.359	19.301	40	4.561	0	34.221	47	-12.779
749.969	V	225	206	42.982	19.301	40	4.561	0	26.844	47	-20.156
749.972	V	82	271	45.349	19.301	40	4.561	0	29.211	47	-17.789
799.958	V	264	187	40.421	19.999	40	4.755	0	25.175	47	-21.825
225.802	V	51	100	51.718	9.848	40	2.381	0	23.947	40	-16.053
42.302	V	170	374	50.364	11.579	40	1.002	0	22.945	40	-17.055
226.24	H	0	400	56.209	9.874	40	2.371	0	28.454	40	-11.546

Table 15. Radiated Emissions Limits, Test Results, ICES-003 Limits, FSP040-DGAA5

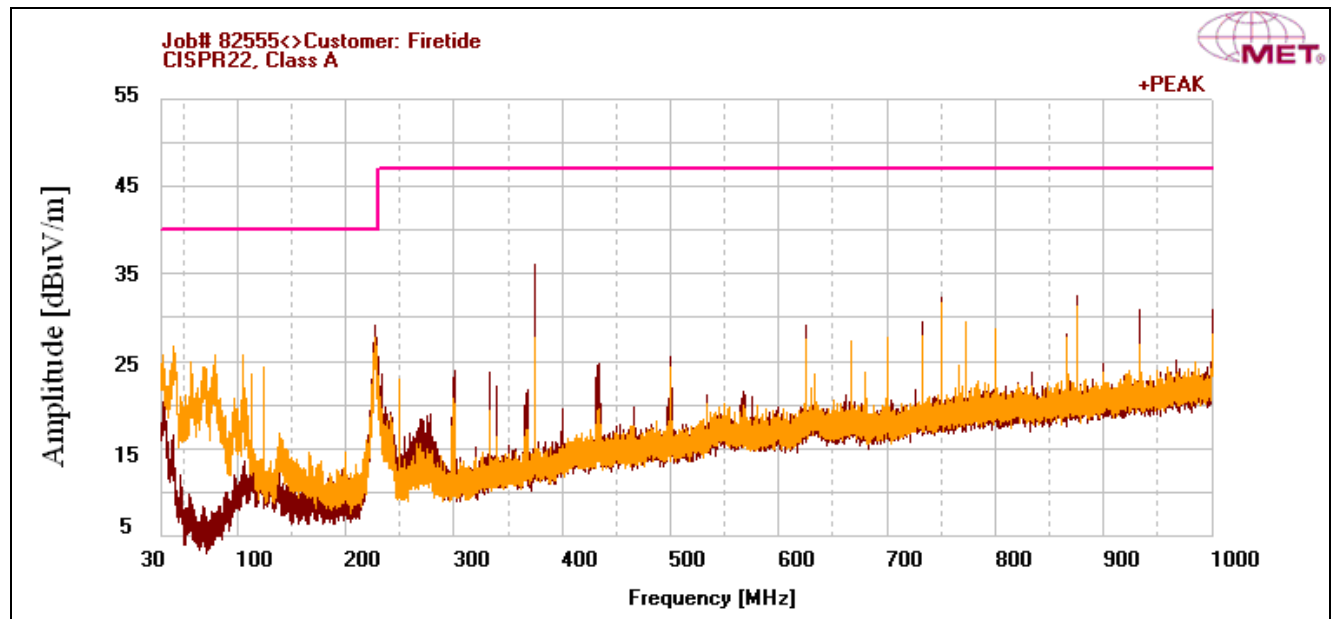

Plot 9. Radiated Emissions, ICES-003 Limits, FSP040-DGAA5

Frequency (MHz)	EUT Azimuth (Degrees)	Antenna Polarity (H/V)	Antenna HEIGHT (m)	Uncorrected Amplitude (dBuV)	Antenna Correction Factor (dB) (+)	Pre Amp Gain (dB)	Cable Loss (dB) (+)	Distance Correction Factor (dB) (-)	Corrected Amplitude (dBuV/m)	Limit (dBuV/m)	Margin (dB)
47.78	V	0	100	34.15	8.444	0	1.757	-10.46	33.891	40	-6.109
227.39	V	322	100	17.21	11.296	0	3.817	-10.46	21.863	40	-18.137
228.2	H	0	100	30.37	11.056	0	3.814	-10.46	34.78	40	-5.22
300	H	322	100	25.65	13.9	0	3.57	-10.46	32.66	47	-14.34
333.33	H	164	100	20.86	14.767	0	3.763	-10.46	28.93	47	-18.07
800	H	330	100	19.91	20.9	0	6.23	-10.46	36.58	47	-10.42

Table 16. Radiated Emissions Limits, Test Results, ICES-003 Limits PoE30U-560

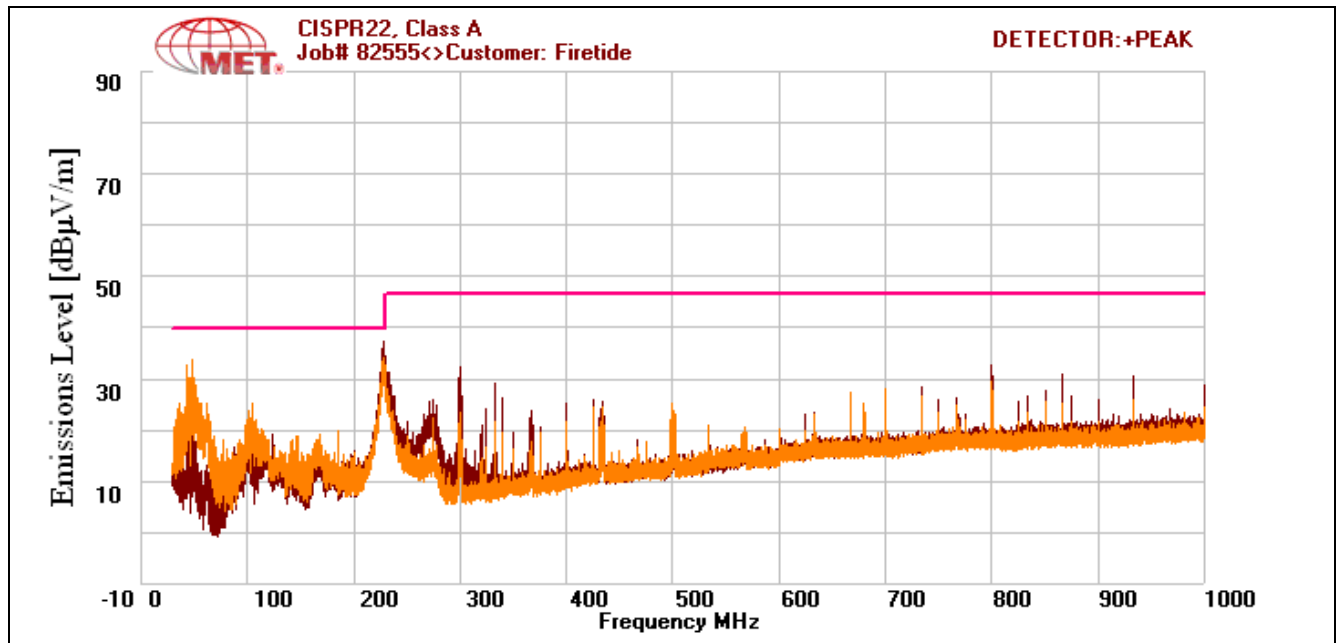

Plot 10. Radiated Emissions, ICES-003 Limits PoE30U-560

Radiated Emission Limits Test Setup



Photograph 6. Radiated Emission, Test Setup

IV. Electromagnetic Compatibility Criteria for Intentional Radiators

Electromagnetic Compatibility Criteria for Intentional Radiators

§ 15.203 Antenna Requirement

Test Requirement: § 15.203: An intentional radiator shall be designed to ensure that no antenna other than that furnished by the responsible party shall be used with the device. The use of a permanently attached antenna or of an antenna that uses a unique coupling to the intentional radiator shall be considered sufficient to comply with the provisions of this section. The manufacturer may design the unit so that a broken antenna can be replaced by the user, but the use of a standard antenna jack or electrical connector is prohibited.

The structure and application of the EUT were analyzed to determine compliance with Section 15.203 of the Rules. Section 15.203 states that the subject device must meet at least one of the following criteria:

- a.) Antenna must be permanently attached to the unit.
- b.) Antenna must use a unique type of connector to attach to the EUT.
- c.) Unit must be professionally installed. Installer shall be responsible for verifying that the correct antenna is employed with the unit.

Test Results: The unit is professionally installed. Therefore, the EUT as tested is compliant with the criteria of §15.203.

Frequency	Gain/Type	Manufacturer
(2.4/5 GHz)	3 dBi Omni	Master Wave Technology CO., LTD

Test Engineer(s): Anderson Soungpanya

Test Date(s): 08/25/10

Electromagnetic Compatibility Criteria for Intentional Radiators

§ 15.207 Conducted Emissions Limits

Test Requirement(s): § 15.207 (a): For an intentional radiator that is designed to be connected to the public utility (AC) power line, the radio frequency voltage that is conducted back onto the AC power line on any frequency or frequencies, within the band 150 kHz to 30MHz, shall not exceed the limits in the following table, as measured using a 50 μ H/50 Ω line impedance stabilization network (LISN). Compliance with the provisions of this paragraph shall be based on the measurement of the radio frequency voltage between each power line and ground at the power terminal. The lower limit applies at the boundary between the frequency ranges.

Frequency range (MHz)	§ 15.207(a), Conducted Limit (dB μ V)	
	Quasi-Peak	Average
* 0.15- 0.45	66 - 56	56 - 46
0.45 - 0.5	56	46
0.5 - 30	60	50

Table 17. Conducted Limits for Intentional Radiators from FCC Part 15 § 15.207(a)

Test Results: Refer to FCC ID: NKR-DNMA83/IC: 4441A-DNMA83.

Electromagnetic Compatibility Criteria for Intentional Radiators

§ 15.247(a) 6 dB and 99% Bandwidth

Test Requirements: § 15.247(a): Operation under the provisions of this section is limited to frequency hopping and digitally modulated intentional radiators that comply with the following provisions:

For systems using digital modulation techniques, the EUT may operate in the 902-928 MHz, 2400-2483.5 MHz and 5725-5850 MHz bands. The minimum 6dB bandwidth shall be at least 500 kHz.

Test Procedure: The transmitter was on and transmitting at the highest output power. The bandwidth of the fundamental frequency was measured with the spectrum analyzer using a RBW approximately 1% of the total emission bandwidth, VBW > RBW. The 6 dB Bandwidth was measured and recorded. The measurements were performed on the low, mid and high channels.

Test Results: Refer to FCC ID: NKR-DNMA83/IC: 4441A-DNMA83.

Electromagnetic Compatibility Criteria for Intentional Radiators

§ 15.247(b) Peak Power Output and RF Exposure

Test Requirements: §15.247(b): The maximum peak output power of the intentional radiator shall not exceed the following:

Digital Transmission Systems (MHz)	Output Limit (Watts)
902-928	1.000
2400-2483.5	1.000
5725- 5850	1.000

Table 18. Output Power Requirements from §15.247

§15.247(c): if transmitting antennas of directional gain greater than 6 dBi are used the peak output power from the intentional radiator shall be reduced below the stated values in the Table 18, as appropriate, by the amount in dB that the directional gain of the antenna exceeds 6 dBi.

Systems operating in the 2400 – 2483.5 MHz band and using a point to point application may employ transmitting antennas with directional gain greater than 6 dBi provided the maximum peak output power of the intentional radiator is reduced by 1 dB for every 3 dB that the directional gain of the antenna exceeds 6 dBi.

Systems operating in the 5725 – 5850 MHz band that are used exclusively for fixed, point-to-point operations may employ transmitting antennas with directional gain greater than 6 dBi without any corresponding reduction in transmitter peak output power.

Fixed, point-to-point operation excludes the use of point-to-multipoint systems, omnidirectional applications, and multiple co-located intentional radiators transmitting the same information. The operator of the spread spectrum intentional radiator or, if the equipment is professionally installed, the installer is responsible for ensuring that the system is used exclusively for fixed, point-to-point operations. The instruction manual furnished with the intentional radiator shall contain language in the installation instructions informing the operator and the installer of this responsibility.

Test Results: Refer to FCC ID: NKR-DNMA83

Electromagnetic Compatibility Criteria for Intentional Radiators

§ 15.247(d) Radiated Spurious Emissions Requirements and Band Edge

Test Requirements: §15.247(d); §15.205: Emissions outside the frequency band.

§15.247(d): In any 100 kHz bandwidth outside the frequency band in which the spread spectrum or digitally modulated intentional radiator is operating, the radio frequency power that is produced by the intentional radiator shall be at least 20 dB below that in the 100 kHz bandwidth within the band that contains the highest level of the desired power, based on either an RF conducted or a radiated measurement. Attenuation below the general limits specified in § 15.209(a) is not required. In addition, radiated emissions which fall in the restricted bands, as defined in § 15.205(a), must also comply with the radiated emission limits specified in § 15.209(a).

§15.205(a): Except as shown in paragraph (d) of this section, only spurious emissions are permitted in any of the frequency bands listed below:

MHz	MHz	MHz	GHz
0.090–0.110-----	16.42–16.423	399.9–410	4.5–5.15
¹ 0.495–0.505-----	16.69475–16.69525	608–614	5.35–5.46
2.1735–2.1905-----	16.80425–16.80475	960–1240	7.25–7.75
4.125–4.128-----	25.5–25.67	1300–1427	8.025–8.5
4.17725–4.17775-----	37.5–38.25	1435–1626.5	9.0–9.2
4.20725–4.20775-----	73–74.6	1645.5–1646.5	9.3–9.5
6.215–6.218-----	74.8–75.2	1660–1710	10.6–12.7
6.26775–6.26825-----	108–121.94	1718.8–1722.2	13.25–13.4
6.31175–6.31225-----	123–138	2200–2300	14.47–14.5
8.291–8.294-----	149.9–150.05	2310–2390	15.35–16.2
8.362–8.366-----	156.52475–156.52525	2483.5–2500	17.7–21.4
8.37625–8.38675-----	156.7–156.9	2655–2900	22.01–23.12
8.41425–8.41475-----	162.0125–167.17	3260–3267	23.6–24.0
12.29–12.293-----	167.72–173.2	3332–3339	31.2–31.8
12.51975–12.52025-----	240–285	3345.8–3358.36	43–36.5
12.57675–12.57725-----	322–335.4	3600–4400	(²)

Table 19. Restricted Bands of Operation

¹ Until February 1, 1999, this restricted band shall be 0.490 – 0.510 MHz.

² Above 38.6

Test Requirement(s): § 15.209 (a): Except as provided elsewhere in this subpart, the emissions from an intentional radiator shall not exceed the field strength levels specified in Table 20.

Frequency (MHz)	§ 15.209(a), Radiated Emission Limits (dB μ V) @ 3m
30 - 88	40.00
88 - 216	43.50
216 - 960	46.00
Above 960	54.00

Table 20. Radiated Emissions Limits Calculated from FCC Part 15, § 15.209 (a)

Test Results: Refer to FCC ID: NKR-DNMA83/IC: 4441A-DNMA83.

Electromagnetic Compatibility Criteria for Intentional Radiators

RSS-GEN Receiver Spurious Emissions Requirements

Test Requirements: The following receiver spurious emission limits shall be complied with:

- (a) If a radiated measurement is made, all spurious emissions shall comply with the limits of Table 21.

Spurious Frequency (MHz)	Field Strength (microvolt/m at 3 metres)
30 – 88	100
88 – 216	150
216 – 960	200
Above 960	500

Table 21. Spurious Emission Limits for Receivers

- (b) If a conducted measurement is made, no spurious output signals appearing at the antenna terminals shall exceed 2 nanowatts per any 4 kHz spurious frequency in the band 30-1000 MHz, or 5 nanowatts above 1 GHz.

Test Results: Refer to FCC ID: NKR-DNMA83/IC: 4441A-DNMA83.

Electromagnetic Compatibility Criteria for Intentional Radiators

§ 15.247(d) RF Conducted Spurious Emissions Requirements and Band Edge

Test Requirement: **15.247(d)** In any 100 kHz bandwidth outside the frequency band in which the spread spectrum or digitally modulated intentional radiator is operating, the radio frequency power that is produced by the intentional radiator shall be at least 20 dB below that in the 100 kHz bandwidth within the band that contains the highest level of the desired power, based on either an RF conducted or a radiated measurement, provided the transmitter demonstrates compliance with the peak conducted power limits. If the transmitter complies with the conducted power limits based on the use of RMS averaging over a time interval, as permitted under paragraph (b)(3) of this section, the attenuation required under this paragraph shall be 30 dB instead of 20 dB.

Test Results: Refer to FCC ID: NKR-DNMA83/IC: 4441A-DNMA83.

Electromagnetic Compatibility Criteria for Intentional Radiators

§ 15.247(e) Peak Power Spectral Density

Test Requirements: §15.247(e): For digitally modulated systems, the peak power spectral density conducted from the intentional radiator to the antenna shall not be greater than 8dBm in any 3 kHz band during any time interval of continuous transmission.

Test Results: Refer to FCC ID: NKR-DNMA83/IC: 4441A-DNMA83.

IV. Test Equipment

Test Equipment

Calibrated test equipment utilized during testing was maintained in a current state of calibration per the requirements of ANSI/NCSL Z540-1-1994 and ANSI/ISO/IEC 17025:2000.

MET Asset #	Equipment	Manufacturer	Model	Last Cal Date	Cal Due Date
1S2421	EMI TEST RECEIVER	ROHDE & SCHWARZ	ESIB7	7/06/2010	7/06/2011
1S2506	FSP SPECTRUM ANALYZER	RHODE & SCHWARZ	1164.4391.30	6/04/2010	6/04/2011
1U0271	PREAMPLIFIER (1GHZ-27GHZ)	AML COMMUNICATIONS	AML0126L3801	SEE NOTE	
1S2657	SCREEN ROOM	ETS LINDGREN	14W-2/2-0	7/20/2010	7/20/2011
1S2481	10M CHAMBER	ETS-LINDGREN	DKE 8X8 DBL	10/19/2009	10/19/2010
1S2501	EMI RECEIVER	ROHDE&SCHWARZ	ESU40	06/03/2010	06/03/2011
1S2484	BILOG ANTENNA	TESEQ	CBL6112D	1/27/2009	1/27/2011
1S2399	TURNTABLE CONTROLLER	SUNOL SCIENCE	SC99V	NOT REQUIRED	
1S2522	DIGITAL THERMO/HYGROMETER	CONTROL COMPANY	11-661-7D	11/11/2009	11/11/2010
1S2482	5M CHAMBER	PANASHIELD	N/A	10/16/2009	10/16/2010
1S2603	DOUBLE RIDGED WAVEGUIDE HORN	ETS-LINGREN	3117	04/09/2009	04/09/2011
1S2121	PRE-AMPLIFIER	HEWLETT PACKARD	8449B	SEE NOTE	
N/A	HIGH PASS FILTER	MICRO-TRONICS	HPM13146	SEE NOTE	
1S2034	COUPLER, DIRECTIONAL 1-20 GHZ	KRYTAR	101020020	SEE NOTE	
1S2583	SPECTRUM ANALYZER	AGILENT	E4447A	01/26/2010	01/26/2011
1S2460	ANALYZER, SPECTRUM 9 KHZ-40GHZ	AGILENT	E4407B	07/13/2010	07/213/2011
1S2128	HARMONIC MIXER	HEWLETT PACKARD	11970A	11/22/2008	11/22/2010
1S2129	HARMONIC MIXER	HEWLETT PACKARD	11970K	11/22/2008	11/22/2010

Table 22. Test Equipment List



V. Certification & User's Manual Information

Certification & User's Manual Information

A. Certification Information

The following is extracted from Title 47 of the Code of Federal Regulations, Part 2, Subpart I — Marketing of Radio frequency devices:

§ 2.801 Radio-frequency device defined.

As used in this part, a radio-frequency device is any device which in its operation is capable of Emitting radio-frequency energy by radiation, conduction, or other means. Radio- frequency devices include, but are not limited to:

- (a) The various types of radio communication transmitting devices described throughout this chapter.
- (b) *The incidental, unintentional and intentional radiators defined in Part 15 of this chapter.*
- (c) The industrial, scientific, and medical equipment described in Part 18 of this chapter.
- (d) Any part or component thereof which in use emits radio-frequency energy by radiation, conduction, or other means.

§ 2.803 Marketing of radio frequency devices prior to equipment authorization.

- (a) Except as provided elsewhere in this chapter, no person shall sell or lease, or offer for sale or lease (including advertising for sale or lease), or import, ship or distribute for the purpose of selling or leasing or offering for sale or lease, any radio frequency device unless:
 - (1) In the case of a device subject to certification, such device has been authorized by the Commission in accordance with the rules in this chapter and is properly identified and labeled as required by §2.925 and other relevant sections in this chapter; or
 - (2) In the case of a device that is not required to have a grant of equipment authorization issued by the Commission, but which must comply with the specified technical standards prior to use, such device also complies with all applicable administrative (including verification of the equipment or authorization under a Declaration of Conformity, where required), technical, labeling and identification requirements specified in this chapter.
- (d) Notwithstanding the provisions of paragraph (a) of this section, the offer for sale solely to business, commercial, industrial, scientific or medical users (but not an offer for sale to other parties or to end users located in a residential environment) of a radio frequency device that is in the conceptual, developmental, design or pre-production stage is permitted prior to equipment authorization or, for devices not subject to the equipment authorization requirements, prior to a determination of compliance with the applicable technical requirements *provided* that the prospective buyer is advised in writing at the time of the offer for sale that the equipment is subject to the FCC rules and that the equipment will comply with the appropriate rules before delivery to the buyer or to centers of distribution.

- (e)(1) Notwithstanding the provisions of paragraph (a) of this section, prior to equipment authorization or determination of compliance with the applicable technical requirements any radio frequency device may be operated, but not marketed, for the following purposes and under the following conditions:
- (i) *Compliance testing*;
 - (ii) Demonstrations at a trade show provided the notice contained in paragraph (c) of this section is displayed in a conspicuous location on, or immediately adjacent to, the device;
 - (iii) Demonstrations at an exhibition conducted at a business, commercial, industrial, scientific or medical location, but excluding locations in a residential environment, provided the notice contained in paragraphs (c) or (d) of this section, as appropriate, is displayed in a conspicuous location on, or immediately adjacent to, the device;
 - (iv) Evaluation of product performance and determination of customer acceptability, provided such operation takes place at the manufacturer's facilities during developmental, design or pre-production states; or
 - (v) Evaluation of product performance and determination of customer acceptability where customer acceptability of a radio frequency device cannot be determined at the manufacturer's facilities because of size or unique capability of the device, provided the device is operated at a business, commercial, industrial, scientific or medical user's site, but not at a residential site, during the development, design or pre-production stages.
- (e)(2) For the purpose of paragraphs (e)(1)(iv) and (e)(1)(v) of this section, the term *manufacturer's facilities* includes the facilities of the party responsible for compliance with the regulations and the manufacturer's premises, as well as the facilities of other entities working under the authorization of the responsible party in connection with the development and manufacture, but not the marketing, of the equipment.
- (f) For radio frequency devices subject to verification and sold solely to business, commercial, industrial, scientific and medical users (excluding products sold to other parties or for operation in a residential environment), parties responsible for verification of the devices shall have the option of ensuring compliance with the applicable technical specifications of this chapter at each end user's location after installation, provided that the purchase or lease agreement includes a proviso that such a determination of compliance be made and is the responsibility of the party responsible for verification of the equipment.

Certification & User's Manual Information

The following is extracted from Title 47 of the Code of Federal Regulations, Part 2, Subpart J — Equipment Authorization Procedures:

§ 2.901 Basis and Purpose

- (a) In order to carry out its responsibilities under the Communications Act and the various treaties and international regulations, and in order to promote efficient use of the radio spectrum, the Commission has developed technical standards for radio frequency equipment and parts or components thereof. The technical standards applicable to individual types of equipment are found in that part of the rules governing the service wherein the equipment is to be operated.¹ *In addition to the technical standards provided, the rules governing the service may require that such equipment be verified by the manufacturer or importer, be authorized under a Declaration of Conformity, or receive an equipment authorization from the Commission by one of the following procedures: certification or registration.*
- (b) The following sections describe the verification procedure, the procedure for a Declaration of Conformity, and the procedures to be followed in obtaining certification from the Commission and the conditions attendant to such a grant.

§ 2.907 Certification.

- (a) Certification is an equipment authorization issued by the Commission, based on representation and test data submitted by the applicant.
- (b) Certification attaches to all units subsequently marketed by the grantee which are identical (see Section 2.908) to the sample tested except for permissive changes or other variations authorized by the Commission pursuant to Section 2.1043.

¹ In this case, the equipment is subject to the rules of Part 15. More specifically, the equipment falls under Subpart B (of Part 15), which deals with unintentional radiators.

Certification & User's Manual Information

§ 2.948 Description of measurement facilities.

- (a) Each party making measurements of equipment that is subject to an equipment authorization under Part 15 or Part 18 of this chapter, regardless of whether the measurements are filed with the Commission or kept on file by the party responsible for compliance of equipment marketed within the U.S. or its possessions, shall compile a description of the measurement facilities employed.
- (1) If the measured equipment is subject to the verification procedure, the description of the measurement facilities shall be retained by the party responsible for verification of the equipment.
- (i) *If the equipment is verified through measurements performed by an independent laboratory, it is acceptable for the party responsible for verification of the equipment to rely upon the description of the measurement facilities retained by or placed on file with the Commission by that laboratory. In this situation, the party responsible for the verification of the equipment is not required to retain a duplicate copy of the description of the measurement facilities.*
- (ii) If the equipment is verified based on measurements performed at the installation site of the equipment, no specific site calibration data is required. It is acceptable to retain the description of the measurement facilities at the site at which the measurements were performed.
- (2) If the equipment is to be authorized by the Commission under the certification procedure, the description of the measurement facilities shall be filed with the Commission's Laboratory in Columbia, Maryland. The data describing the measurement facilities need only be filed once but must be updated as changes are made to the measurement facilities or as otherwise described in this section. At least every three years, the organization responsible for filing the data with the Commission shall certify that the data on file is current.

Certification & User's Manual Information

Label and User's Manual Information

The following is extracted from Title 47 of the Code of Federal Regulations, Part 15, Subpart A — General:

§ 15.19 Labeling requirements.

(a) *In addition to the requirements in Part 2 of this chapter, a device subject to certification or verification shall be labeled as follows:*

- (1) Receivers associated with the operation of a licensed radio service, e.g., FM broadcast under Part 73 of this chapter, land mobile operation under Part 90, etc., shall bear the following statement in a conspicuous location on the device:

This device complies with Part 15 of the FCC Rules. Operation is subject to the condition that this device does not cause harmful interference.

- (2) A stand-alone cable input selector switch, shall bear the following statement in a conspicuous location on the device:

This device is verified to comply with Part 15 of the FCC Rules for use with cable television service.

- (3) All other devices shall bear the following statement in a conspicuous location on the device:

This device complies with Part 15 of the FCC Rules. Operation is subject to the following two conditions: (1) This device may not cause harmful interference, and (2) this device must accept any interference received, including interference that may cause undesired operation.

- (4) Where a device is constructed in two or more sections connected by wires and marketed together, the statement specified under paragraph (a) of this section is required to be affixed only to the main control unit.

- (5) When the device is so small or for such use that it is not practicable to place the statement specified under paragraph (a) of this section on it, the information required by this paragraph shall be placed in a prominent location in the instruction manual or pamphlet supplied to the user or, alternatively, shall be placed on the container in which the device is marketed. However, the FCC identifier or the unique identifier, as appropriate, must be displayed on the device.

§ 15.21 Information to user.

The users manual or instruction manual for an intentional or unintentional radiator shall caution the user that changes or modifications not expressly approved by the party responsible for compliance could void the user's authority to operate the equipment.

Verification & User's Manual Information

The following is extracted from Title 47 of the Code of Federal Regulations, Part 15, Subpart B — Unintentional Radiators:

§ 15.105 Information to the user.

- (a) For a Class A digital device or peripheral, the instructions furnished the user shall include the following or similar statement, placed in a prominent location in the text of the manual:

Note: This equipment has been tested and found to comply with the limits for a Class A digital device, pursuant to Part 15 of the FCC Rules. These limits are designed to provide reasonable protection against harmful interference when the equipment is operated in a commercial environment. This equipment generates, uses, and can radiate radio frequency energy and, if not installed and used in accordance with the instruction manual, may cause harmful interference to radio communications. Operation of this equipment in a residential area is likely to cause harmful interference in which case the user will be required to correct the interference at own expense.

- (b) For a Class B digital device or peripheral, the instructions furnished the user shall include the following or similar statement, placed in a prominent location in the text of the manual:

Note: This equipment has been tested and found to comply with the limits for a Class B digital device, pursuant to Part 15 of the FCC Rules. These limits are designed to provide reasonable protection against harmful interference when the equipment is operated in a residential environment. This equipment generates, uses, and can radiate radio frequency energy and, if not installed and used in accordance with the instruction manual, may cause harmful interference to radio communications. However, there is no guarantee that interference will not occur in a particular installation. If this equipment does cause harmful interference to radio or television reception, which can be determined by turning the equipment off and on, the user is encouraged to try to correct the interference by one or more of the following measures:

- Reorient or relocate the receiving antenna.
- Increase the separation between the equipment and receiver.
- Connect the equipment into an outlet on a circuit different from that to which the receiver is connected.
- Consult the dealer or an experienced radio/TV technician for help.

ICES-003 Procedural & Labeling Requirements

From the Industry Canada Electromagnetic Compatibility Advisory Bulletin entitled, "Implementation and Interpretation of the Interference-Causing Equipment Standard for Digital Apparatus, ICES-003" (EMCAB-3, Issue 2, July 1995):

"At present, CISPR 22: 2002 and ICES technical requirements are essentially equivalent. Therefore, if you have CISPR 22: 2002 approval by meeting CISPR Publication 22, the only additional requirements are: to attach a note to the report of the test results for compliance, indicating that these results are deemed satisfactory evidence of compliance with ICES-003 of the Canadian Interference-Causing Equipment Regulations; to maintain these records on file for the requisite five year period; and to provide the device with a notice of compliance in accordance with ICES-003."

Procedural Requirements:

According to Industry Canada's Interference Causing Equipment Standard for Digital Apparatus ICES-003 Issue 4, February 2004:

- Section 6.1: A record of the measurements and results, showing the date that the measurements were completed, shall be retained by the manufacturer or importer for a period of at least five years from the date shown in the record and made available for examination on the request of the Minister.
- Section 6.2: A written notice indicating compliance must accompany each unit of digital apparatus to the end user. The notice shall be in the form of a label that is affixed to the apparatus. Where because of insufficient space or other constraints it is not feasible to affix a label to the apparatus, the notice may be in the form of a statement in the user's manual.

Labeling Requirements:

The suggested text for the notice, in English and in French, is provided below, from the Annex of ICES-003:

This Class [²] digital apparatus complies with Canadian ICES-003.

Cet appareil numérique de la classe [¹] est conforme à la norme NMB-003 du Canada.

² Insert either A or B but not both as appropriate for the equipment requirements.

End of Report