

FCC TEST REPORT

according to

FCC Rules and Regulations

Part 15 Subpart C & E

Applicant	Firetide Inc.
Address	16795 Lark Ave., Ste. 200, Los Gatos, CA 95032
Equipment	HotPort Wireless Mesh Node
Model No.	3100
FCC ID	REP-3103-1
Trade Name	Firetide

Laboratory accreditation



1332

ILAC MRA

- The test result refers exclusively to the test presented test model / sample.,
- Without written approval of **Exclusive Certification Corp.** the test report shall not be reproduced except in full.
- The EUT is also considered as a kind of computer peripheral, because the connection to computer is necessary for typical use. It has been verified to comply with the requirements of FCC Part 15, Subpart B, Class B (DoC). The test report has been issued separately.

CONTENTS

1.	Report of Measurements and Examinations.....	5
1.1.	List of Measurements and Examinations	5
2.	Test Configuration of Equipment under Test.....	6
2.1.	Test Mode and Test Software.....	6
2.2.	Description of Test System.....	6
2.3.	Connection Diagram of Test System.....	6
2.4.	Feature of Equipment under Test.....	7
2.5.	RF Module Specifications	7
2.6.	History of this test report	7
3.	General Information of Test.....	8
4.	Antenna Requirements	9
4.1.	Standard Applicable	9
4.2.	Antenna Construction and Directional Gain.....	9
5.	Test of Conducted Emission	10
5.1.	Test Procedures	10
5.2.	Typical Test Setup Layout of Conducted Emission.....	11
5.3.	Conducted Emission Requirement	11
5.4.	Test Result and Data.....	12
6.	Test of Radiated Emission	25
6.1.	Test Procedures	25
6.2.	Typical Test Setup Layout of Radiated Emission.....	25
6.3.	Test Result of Radiated Emission	26
7.	Peak Transmit Power.....	34
7.1.	Test Procedure	34
7.2.	Test Setup Layout	34
7.3.	Test Result and Data.....	34
8.	Peak Power Excursion.....	41
8.1.	Test Procedure	41
8.2.	Test Setup Layout	41
8.3.	Test Result and Data.....	41
9.	Peak Power Spectral Density.....	45
9.1.	Test Procedure	45
9.2.	Test Setup Layout	45
9.3.	Test Result and Data.....	45
10.	Frequency Stability.....	49
10.1.	Test Procedure	49
10.2.	Test Setup Layout	49
10.3.	Test Result and Data.....	50
11.	Band Edges Measurement	51
11.1.	Test Procedure	51
11.2.	Test Result and Data.....	51
11.3.	Restrict Band Emission Measurement Data	53
12.	6dB Bandwidth	54
12.1.	Test Procedure	54
12.2.	Test Setup Layout	54

- 12.3. Test Result and Data 54
- 13. Maximum Peak Output Power 57
 - 13.1. Test Procedure 57
 - 13.2. Test Setup Layout 57
 - 13.3. Test Result and Data 57
- 14. Band Edges Measurement 60
 - 14.1. Test Procedure 60
 - 14.2. Test Result and Data 60
- 15. Power Spectral Density 63
 - 15.1. Test Procedure 63
 - 15.2. Test Setup Layout 63
 - 15.3. Test Result and Data 63
- 16. Restricted Bands of Operation 66
 - 16.1. Labeling Requirement 66
- 17. RF Exposure 67
 - 17.1. Limit For Maximum Permissible Exposure (MPE) 67
 - 17.2. MPE Calculations 68
 - 17.3. FCC Radiation Exposure Statement 68
- 18. List of Measuring Equipment Used 69
- Appendix A. Photographs of EUT A1 ~ A7

CERTIFICATE OF COMPLIANCE

according to

FCC Rules and Regulations

Part 15 Subpart C & E

Applicant	Firetide Inc.
Address	16795 Lark Ave., Ste. 200, Los Gatos, CA 95032
Equipment	HotPort Wireless Mesh Node
Model No.	3100
FCC ID	REP-3103-1

I HEREBY CERTIFY THAT :

The measurements shown in this test report were made in accordance with the procedures given in **ANSI C63.4** The equipment was **passed** the test performed according to **FCC Rules and Regulations Part 15 Subpart C& E (2003)**. The test was carried out on Feb. 24, 2005 at *Exclusive Certification Corp.*

Signature

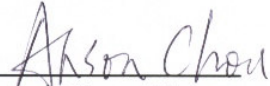
Anson Chou / Manager Feb. 25, 2005

1. Report of Measurements and Examinations

1.1. List of Measurements and Examinations

For Frequency 5.15GHz ~ 5.35GHZ

Applied Standard : FCC Part 15, Subpart E (Section 15.407)		
FCC Rule	Description of Test	Result
15.407(b)(5)	. Conducted Emission	Pass
15.407(b/1/2/3)(b)(5)	. Radiated Emission	Pass
15.407(a/1/2/3)	. Peak Transmit Power	Pass
15.407(a)(6)	. Peak Power Excursion	Pass
15.407(a/1/2/3)	. Peak Power Spectral Density	Pass
15.407(g)	. Frequency Stability	Pass

For Frequency 5.725GHz ~ 5.85GHZ

Applied Standard : FCC Part 15, Subpart C (Section 15.247)		
FCC Rule	Description of Test	Result
15.203	. Antenna Requirement	Pass
15.207	. Conducted Emission	Pass
15.209	. Radiated Emission	Pass
15.247(a)(2)	. 6dB Bandwidth	Pass
15.247(b)	. Maximum Peak Output Power	Pass
15.247(c)	. 100kHz Bandwidth of Frequency Band Edges	Pass
15.247(d)	. Power Spectral Density	Pass
1.1307 1.1310 2.1091 2.1093	. RF Exposure Compliance	Pass

Test by: Jerry Feb. 17, 2005

2. Test Configuration of Equipment under Test

2.1. Test Mode and Test Software

The following test mode and test software was performed for conduction and radiation test:

- 802.11a (CH 36: Test Define CH1: 5180MHz)
- 802.11a (CH 48: Test Define CH4: 5240MHz)
- 802.11a (CH 52: Test Define CH5: 5260MHz)
- 802.11a (CH 64: Test Define CH8: 5320MHz)
- 802.11a (CH 149: Test Define CH9: 5745MHz)
- 802.11a (CH 161: Test Define CH12: 5805MHz)
- An executive programs, "Hyper Terminal" Application under WIN XP.

2.2. Description of Test System

Device	Manufacturer	Model No.	Description
PC	IBM	IGV	Power Cable, Unshielding 1.8 m
Monitor	SlimAGE	510A	Power Cable, Adapter Unshielding 1.8 m Data Cable, VGA shielding 1.35 m
Keyboard	IBM	KB-0225	Data Cable, PS2 shielding 1.85 m
Mouse	IBM	MO28VO	Data Cable, USB shielding 1.85 m
Modem	ACEXX	DM-1414	Power Cable, Adapter Unshielding 1.8 m Data Cable, RS232 Unshielding 1.35 m
Printer	HP	Desk Jet400	Power Cable, Adapter Unshielding 1.8 m Data Cable, PRINT shielding 1.6 m
Notebook (Remote site)	IBM	R40(2723-BV1)	Power Cable, Adapter Unshielding 1.8 m

Use Cable:

Cable	Description
RJ-45	Unshielding, 10m
RJ-45*3	Unshielding, 1.8m

2.3. Connection Diagram of Test System

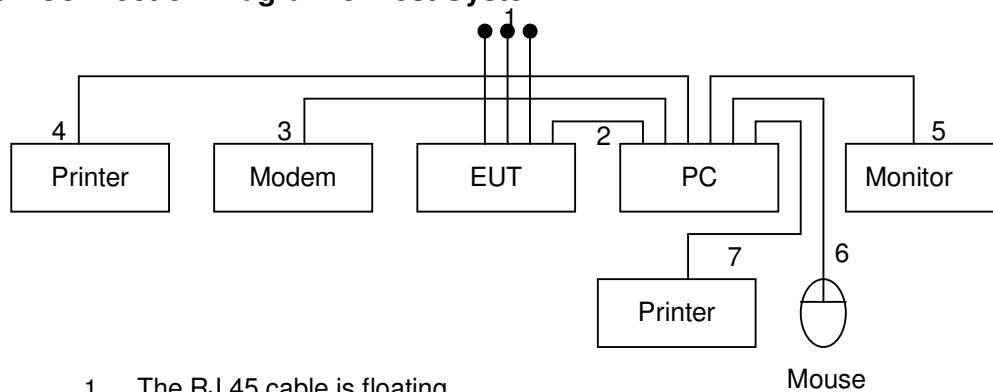

1. The RJ 45 cable is floating.
2. The I/O cable is connected from PC to the EUT.
3. The I/O cable is connected from PC to the Modem.
4. The I/O cable is connected from PC to the Printer.
5. The I/O cable is connected from PC to the Monitor.
6. The I/O cable is connected from PC to the Mouse.
7. The I/O cable is connected from PC to the Printer.

2.4. Feature of Equipment under Test

<p>Protocol Firetide Mesh Routing Protocol (FMRP)</p> <p>Encryption</p> <ul style="list-style-type: none"> • 40 bit, 128 bit WEP keys • 128 bit, 256 bit AES keys <p>Network ports</p> <ul style="list-style-type: none"> • Four 10/100 Base-TX (RJ-45) • IEEE 802.3, 802.3u compliant • CSMA/CD 10/100 autosense <p>Enclosure</p> <ul style="list-style-type: none"> • Two antenna connectors (SMA reverse polarity) • One power connector • Four Ethernet data connectors (RJ-45) • System indicator LEDs (power, status, mesh, fault). • Ethernet indicator LEDs (link status, activity) • Security slot for physical locking device • Reset button (recessed) • Weight: 2.1 lbs (.95 Kg) without external transformer • Dimensions: 10" x 6" x 1" (25.4 cm x 15.2 cm x 2.5 cm) 	<p>Power</p> <ul style="list-style-type: none"> • 5 VDC input • 100-240 VAC, 50/60 Hz (external transformer) • 13 W power consumption <p>Regulatory Agency Certifications See Appendix C and D for countries of operation and regulatory agency information</p> <p>Environmental specifications</p> <ul style="list-style-type: none"> • Operating temperature: 0° C to +50° C • Storage temperature: -20° C to +70° C • Humidity (non-condensing) 10% to 90% • Storage Humidity (non-condensing): 10% to 90% <p>Warranty One year limited warranty (see warranty card for details)</p>
--	--

2.5. RF Module Specifications

<p>Wireless interface 2.4 GHz spectrum</p> <ul style="list-style-type: none"> • 2.4–2.497 GHz (actual range available for use is subject to country-specific regulatory approvals) • Radio TX Power: Maximum 100mW • Ad Hoc Mode support <p>5 GHz spectrum</p> <ul style="list-style-type: none"> • 5.15 – 5.25 GHz • 5.25 – 5.35 GHz • 5.75 – 5.825 GHz (actual range available for use is subject to country-specific regulatory approvals) • Radio TX Power: Maximum 100mW • Dynamic Frequency Selection (DFS) • Transmit Power Control (TPC) • Ad Hoc Mode support 	<p>Antennas</p> <ul style="list-style-type: none"> • Two detachable, omni directional, vertical polarization antennas <ul style="list-style-type: none"> • Spectrum: 2.4 GHz and 5 GHz • Connectors: SMA reverse polarity • Length: 6.25 in. (15.5 cm) • Range: up to 0.2 Miles (300 Meters) • Gain: up to 6 dBi
---	--

2.6. History of this test report

ORIGINAL.

3. General Information of Test

Test Site:	Exclusive Certification Corp. 4F-2, No. 28, Lane 78, Xing-Ai Rd. Nei-hu, Taipei City 114 Taiwan R.O.C.
Test Site Location (OATS1-SD):	No.68-1, Shihbachongsi, shihding Township, Taipei County 223, Taiwan, R.O.C.
Test Voltage:	AC 110V/ 60Hz
Test in Compliance with:	ANSI C63.4-2003 FCC Part 15 Subpart C & E
Frequency Range Investigated:	AC Power Conducted Emission : from 150kHz to 30 MHz Radiated and conducted Emission: from 30 MHz to 40 GHz
Test Distance:	The test distance of radiated emission from antenna to EUT is 3 M.

4. Antenna Requirements

4.1. Standard Applicable

For intentional device, according to FCC 47 CFR Section 15.203, an intentional radiator shall be designed to ensure that no antenna other than that furnished by the responsible party shall be used with the device.

And according to FCC 47 CFR Section 15.247 (b), if transmitting antennas of directional gain greater than 6dBi are used, the power shall be reduced by the amount in dB that the directional gain of the antenna exceeds 6dBi.

4.2. Antenna Construction and Directional Gain

Antenna type: Reverse SMA connector, dipole antenna.

Antenna Gain: 3 dBi @ 2.4 GHz.

4 dBi @ 5 GHz.

5. Test of Conducted Emission

Conducted Emissions were measured from 150 kHz to 30 MHz with a bandwidth of 9 KHz on the 115 VAC power and return leads of the EUT according to the methods defined in ANSI C63.4-2003 Section 3.1. The EUT was placed on a nonmetallic stand in a shielded room 0.8 meters above the ground plane as shown in section 1.3.1. The interface cables and equipment positioning were varied within limits of reasonable applications to determine the position produced maximum conducted emissions.

5.1. Test Procedures

- a. The EUT was placed 0.4 meter from the conducting wall of the shielding room was kept at least 80 centimeters from any other grounded conducting surface.
- b. Connect EUT to the power mains through a line impedance stabilization network (LISN).
- c. All the support units are connecting to the other LISN.
- d. The LISN provides 50 ohm coupling impedance for the measuring instrument.
- e. The FCC states that a 50 ohm, 50 microhenry LISN should be used.
- f. Both sides of AC line were checked for maximum conducted interference.
- g. The frequency range from 150 kHz to 30 MHz was searched.
- h. Set the test-receiver system to Peak Detect Function and Specified Bandwidth with Maximum Hold Mode.

5.2. Typical Test Setup Layout of Conducted Emission

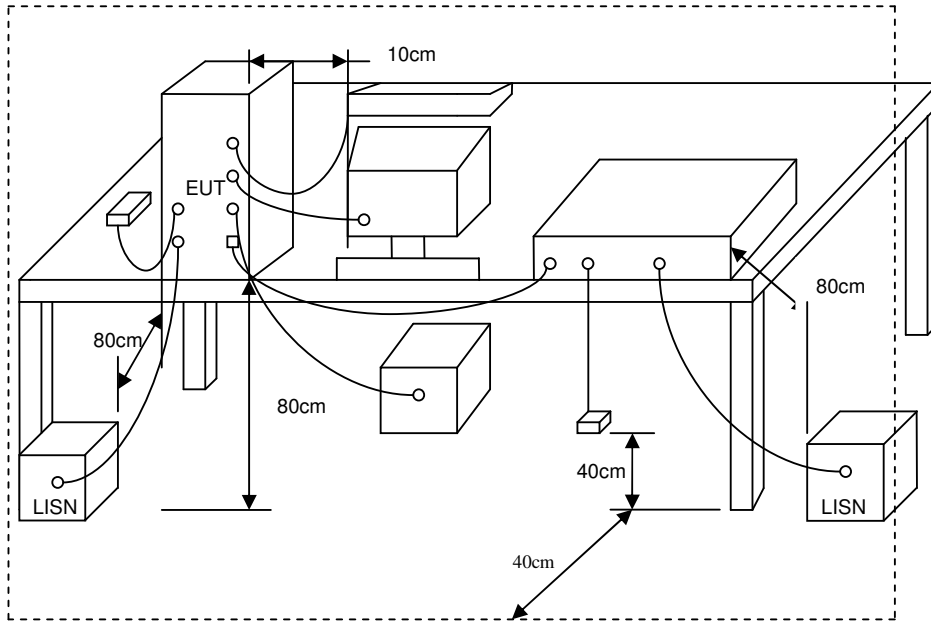

5.3. Conducted Emission Requirement

Except for A digital devices, for equipment that is designed to be connected to the public utility (AC) power line on any frequency voltage that is conducted back onto the AC power line on ant frequency or frequencies within the band 150KHz to 30MHz shall not exceed the limits in the following table, as measured using a 50 μ H/50 ohms line impeddance stabilization network (LISN). Compliance with the provisions of this paragraph shall be based on the measurement of the Radio frequency voltage between each power line and ground at the power terminal. The lower limit applies at the band edges.

Frequency (MHz)	Quasi Peak (dB μ V)	Average (dB μ V)
0.15 – 0.5	66-56*	56-46*
0.5 – 5.0	56	46
5.0 – 30.0	60	50

5.4. Test Result and Data

EUT : 3100
 Power : AC 110V
 Test Mode : 802.11a CH 36
 Memo :
 Pol/Phase : NEUTRAL
 Temperature : 26 °C
 Humidity : 61 %

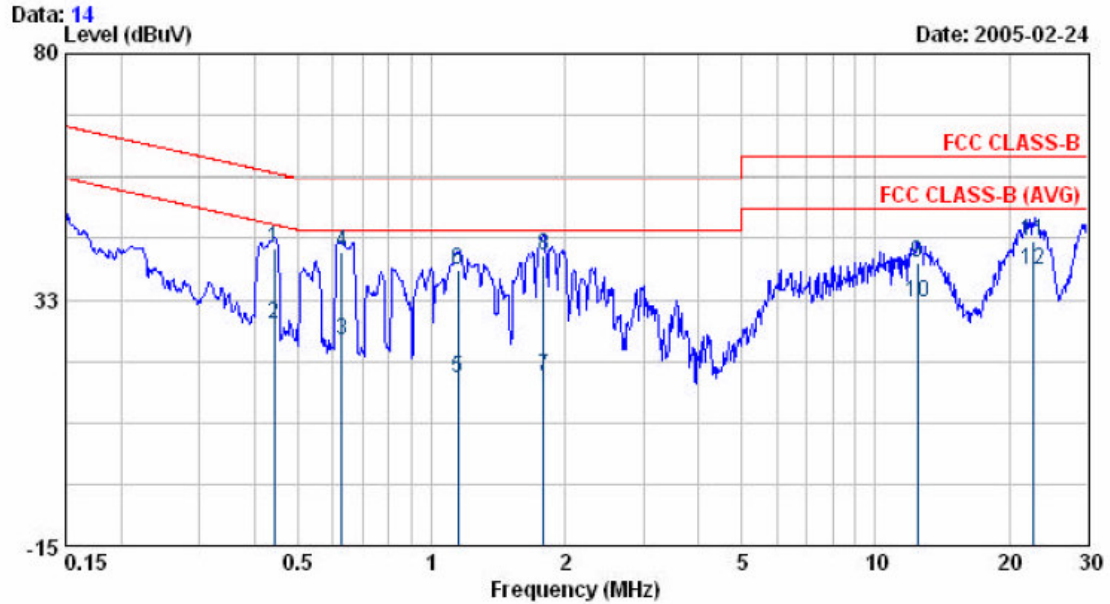

Freq	Read Level	Factor	Level	Limit	Over Limit	Remark
MHz	dBuV	dB	dBuV	dBuV	dBuV	
0.441	41.84	0.49	42.33	57.04	-14.71	QP
0.441	27.48	0.49	27.97	47.04	-19.07	AVERAGE
0.628	24.34	0.45	24.79	46.00	-21.21	AVERAGE
0.628	41.32	0.45	41.77	56.00	-14.23	QP
1.146	17.04	0.42	17.46	46.00	-28.54	AVERAGE
1.146	37.67	0.42	38.09	56.00	-17.91	QP
1.786	17.07	0.48	17.55	46.00	-28.45	AVERAGE
1.786	40.41	0.48	40.89	56.00	-15.11	QP
12.424	38.84	0.66	39.50	60.00	-20.50	QP
12.424	31.23	0.66	31.89	50.00	-18.11	AVERAGE
22.766	43.04	0.76	43.80	60.00	-16.20	QP
22.766	37.39	0.76	38.15	50.00	-11.85	AVERAGE

Remarks: 1. Level = Read Level + Factor
 2. Factor = LISN(ISN) Factor + Cable Loss

EUT : 3100
 Power : AC 110V
 Test Mode : 802.11a CH 36
 Memo :

Pol/Phase : LINE
 Temperature : 26 °C
 Humidity : 61 %

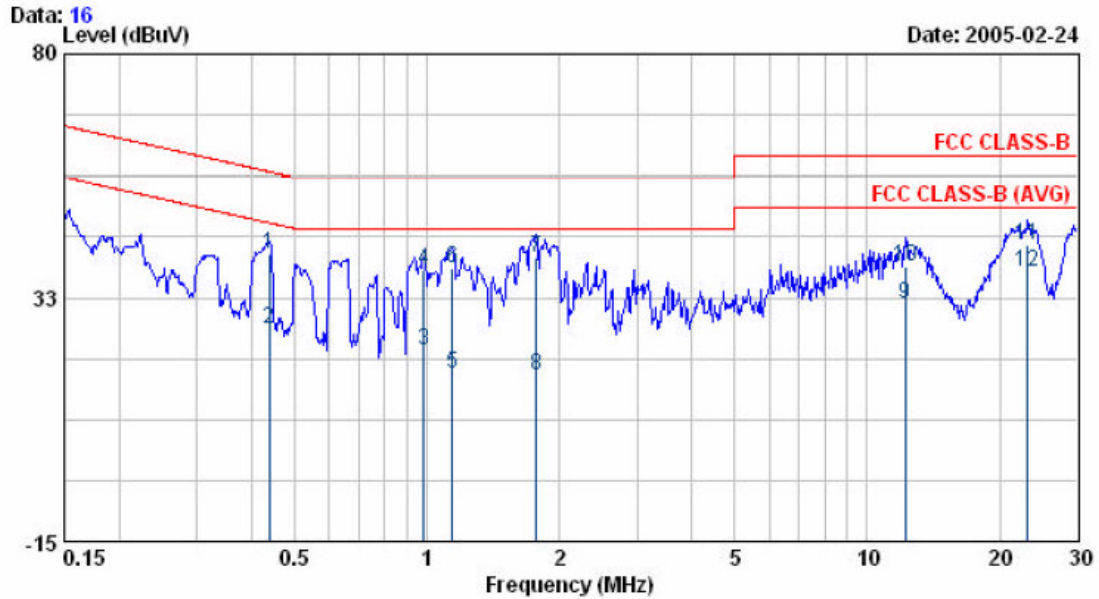

Freq	Read Level	Factor	Level	Limit	Over Limit	Remark
MHz	dBuV	dB	dBuV	dBuV	dBuV	
0.439	40.61	0.49	41.10	57.09	-15.99	QP
0.439	26.00	0.49	26.49	47.09	-20.60	AVERAGE
0.985	21.79	0.40	22.19	46.00	-23.81	AVERAGE
0.985	37.45	0.40	37.85	56.00	-18.15	QP
1.141	17.27	0.42	17.69	46.00	-28.31	AVERAGE
1.141	37.84	0.42	38.26	56.00	-17.74	QP
1.771	39.97	0.48	40.45	56.00	-15.55	QP
1.771	17.01	0.48	17.49	46.00	-28.51	AVERAGE
12.178	30.64	0.59	31.23	50.00	-18.77	AVERAGE
12.178	38.01	0.59	38.60	60.00	-21.40	QP
23.139	41.65	0.96	42.61	60.00	-17.39	QP
23.139	36.54	0.96	37.50	50.00	-12.50	AVERAGE

Remarks: 1. Level = Read Level + Factor
 2. Factor = LISN(ISN) Factor + Cable Loss

EUT : 3100
 Power : AC 110V
 Test Mode : 802.11a CH 48
 Memo :
 Pol/Phase : NEUTRAL
 Temperature : 26 °C
 Humidity : 61 %

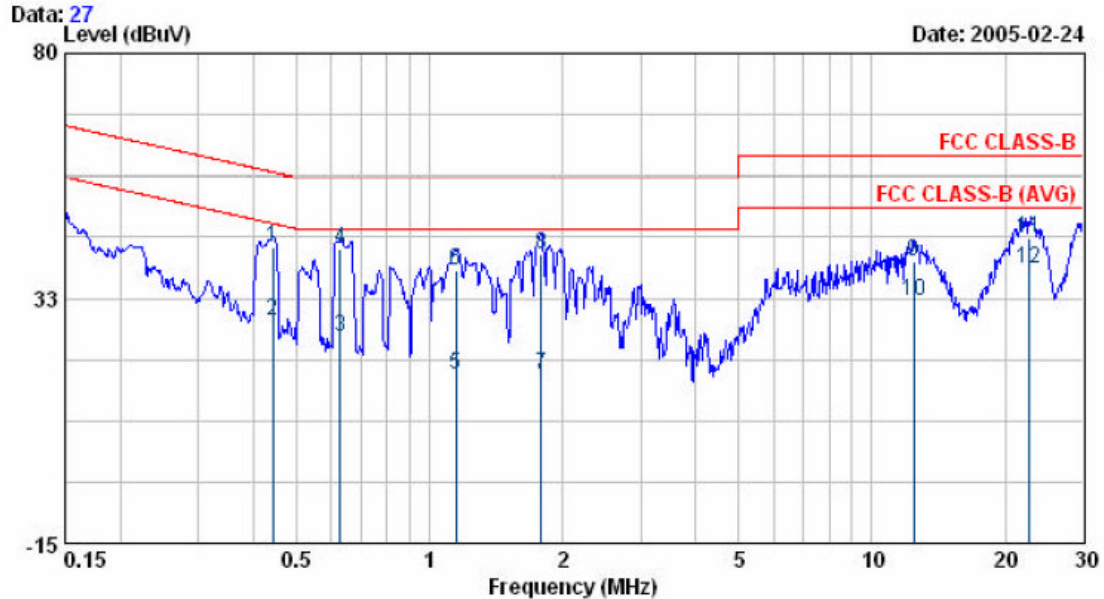

Freq	Read	Factor	Level	Limit	Over	Remark
MHz	dBuV	dB	dBuV	dBuV	dBuV	
0.441	41.92	0.49	42.41	57.04	-14.63	QP
0.441	27.51	0.49	28.00	47.04	-19.04	AVERAGE
0.628	24.41	0.45	24.86	46.00	-21.14	AVERAGE
0.628	41.52	0.45	41.97	56.00	-14.03	QP
1.146	17.25	0.42	17.67	46.00	-28.33	AVERAGE
1.146	37.62	0.42	38.04	56.00	-17.96	QP
1.786	17.25	0.48	17.73	46.00	-28.27	AVERAGE
1.786	40.62	0.48	41.10	56.00	-14.90	QP
12.424	38.95	0.66	39.61	60.00	-20.39	QP
12.424	31.36	0.66	32.02	50.00	-17.98	AVERAGE
22.766	43.25	0.76	44.01	60.00	-15.99	QP
22.766	37.46	0.76	38.22	50.00	-11.78	AVERAGE

Remarks: 1. Level = Read Level + Factor
 2. Factor = LISN(ISN) Factor + Cable Loss

EUT : 3100
 Power : AC 110V
 Test Mode : 802.11a CH 48
 Memo :

Pol/Phase : LINE
 Temperature : 26 °C
 Humidity : 61 %

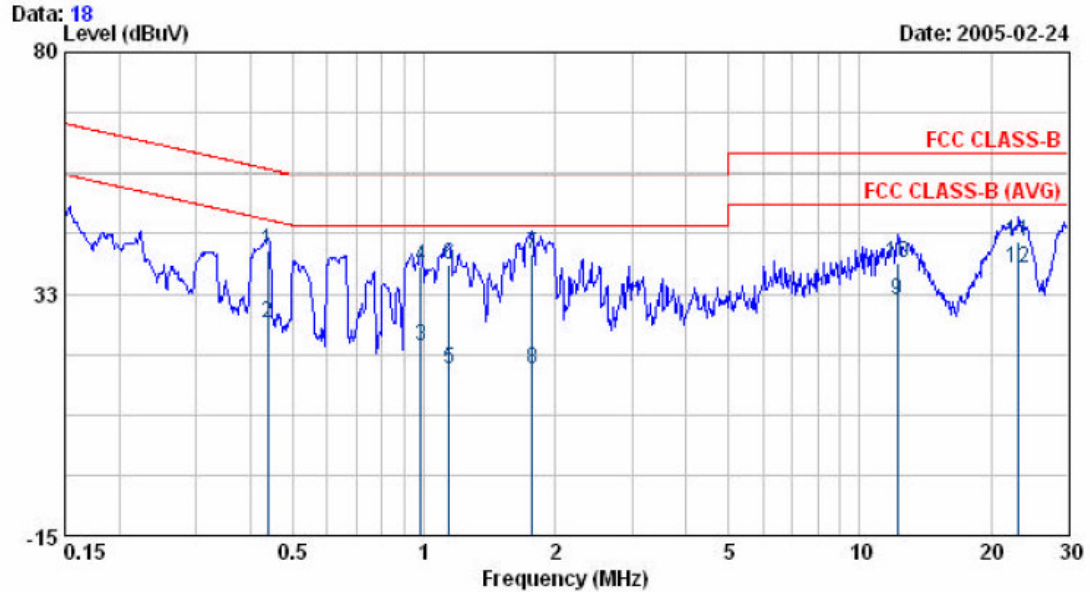

Freq	Read Level	Factor	Level	Limit	Over Limit	Remark
MHz	dBuV	dB	dBuV	dBuV	dBuV	
0.439	40.65	0.49	41.14	57.09	-15.95	QP
0.439	26.12	0.49	26.61	47.09	-20.48	AVERAGE
0.985	21.75	0.40	22.15	46.00	-23.85	AVERAGE
0.985	37.51	0.40	37.91	56.00	-18.09	QP
1.141	17.31	0.42	17.73	46.00	-28.27	AVERAGE
1.141	37.81	0.42	38.23	56.00	-17.77	QP
1.771	39.95	0.48	40.43	56.00	-15.57	QP
1.771	17.21	0.48	17.69	46.00	-28.31	AVERAGE
12.178	30.69	0.59	31.28	50.00	-18.72	AVERAGE
12.178	38.12	0.59	38.71	60.00	-21.29	QP
23.139	41.69	0.96	42.65	60.00	-17.35	QP
23.139	36.59	0.96	37.55	50.00	-12.45	AVERAGE

Remarks: 1. Level = Read Level + Factor
 2. Factor = LISN(ISN) Factor + Cable Loss

EUT : 3100
 Power : AC 110V
 Test Mode : 802.11a CH 52
 Memo :

Pol/Phase : NEUTRAL
 Temperature : 26 °C
 Humidity : 61 %

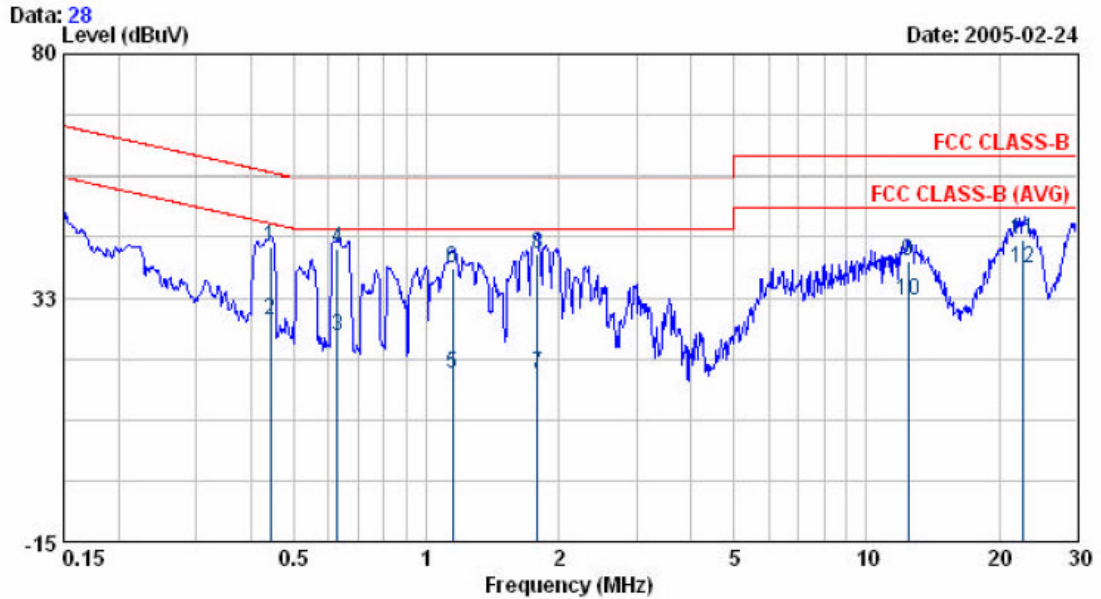

Freq	Read Level	Factor	Level	Limit	Over Limit	Remark
MHz	dBuV	dB	dBuV	dBuV	dBuV	
0.441	41.96	0.49	42.45	57.04	-14.59	QP
0.441	27.59	0.49	28.08	47.04	-18.96	AVERAGE
0.628	24.46	0.45	24.91	46.00	-21.09	AVERAGE
0.628	41.56	0.45	42.01	56.00	-13.99	QP
1.146	17.32	0.42	17.74	46.00	-28.26	AVERAGE
1.146	37.69	0.42	38.11	56.00	-17.89	QP
1.786	17.32	0.48	17.80	46.00	-28.20	AVERAGE
1.786	40.71	0.48	41.19	56.00	-14.81	QP
12.424	38.96	0.66	39.62	60.00	-20.38	QP
12.424	31.41	0.66	32.07	50.00	-17.93	AVERAGE
22.766	43.00	0.76	43.76	60.00	-16.24	QP
22.766	37.51	0.76	38.27	50.00	-11.73	AVERAGE

Remarks: 1. Level = Read Level + Factor
 2. Factor = LISN(ISN) Factor + Cable Loss

EUT : 3100
 Power : AC 110V
 Test Mode : 802.11a CH 52
 Memo :
 Pol/Phase : LINE
 Temperature : 26 °C
 Humidity : 61 %

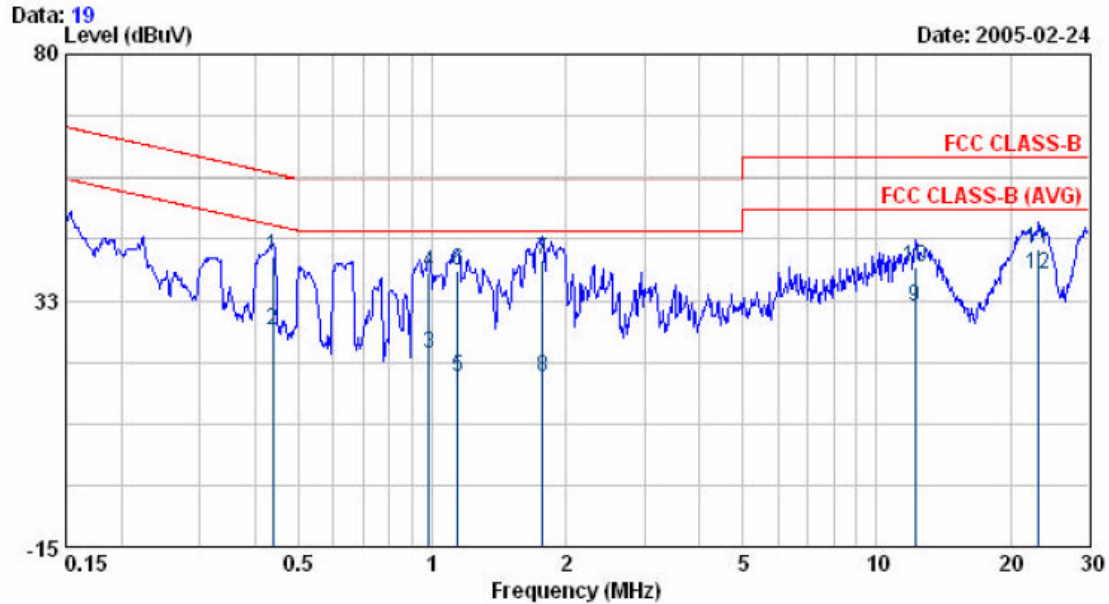

Freq	Read Level	Factor	Level	Limit	Over Limit	Remark
MHz	dBuV	dB	dBuV	dBuV	dBuV	
0.439	40.69	0.49	41.18	57.09	-15.91	QP
0.439	26.32	0.49	26.81	47.09	-20.28	AVERAGE
0.985	21.71	0.40	22.11	46.00	-23.89	AVERAGE
0.985	37.61	0.40	38.01	56.00	-17.99	QP
1.141	17.41	0.42	17.83	46.00	-28.17	AVERAGE
1.141	37.91	0.42	38.33	56.00	-17.67	QP
1.771	39.81	0.48	40.29	56.00	-15.71	QP
1.771	17.26	0.48	17.74	46.00	-28.26	AVERAGE
12.178	30.64	0.59	31.23	50.00	-18.77	AVERAGE
12.178	38.21	0.59	38.80	60.00	-21.20	QP
23.139	41.62	0.96	42.58	60.00	-17.42	QP
23.139	36.61	0.96	37.57	50.00	-12.43	AVERAGE

Remarks: 1. Level = Read Level + Factor
 2. Factor = LISN(ISN) Factor + Cable Loss

EUT : 3100
 Power : AC 110V
 Test Mode : 802.11a CH 64
 Memo :

Pol/Phase : NEUTRAL
 Temperature : 26 °C
 Humidity : 61 %

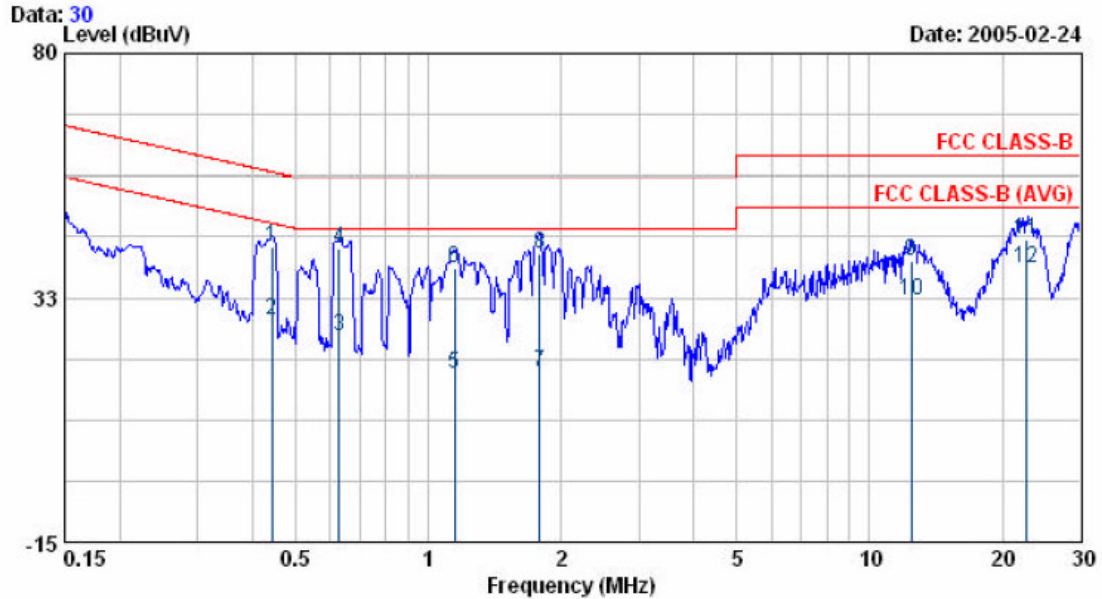

Freq	Read Level	Factor	Level	Limit	Over Limit	Remark
MHz	dBuV	dB	dBuV	dBuV	dBuV	
0.441	41.95	0.49	42.44	57.04	-14.60	QP
0.441	27.65	0.49	28.14	47.04	-18.90	AVERAGE
0.628	24.61	0.45	25.06	46.00	-20.94	AVERAGE
0.628	41.65	0.45	42.10	56.00	-13.90	QP
1.146	17.45	0.42	17.87	46.00	-28.13	AVERAGE
1.146	37.75	0.42	38.17	56.00	-17.83	QP
1.786	17.45	0.48	17.93	46.00	-28.07	AVERAGE
1.786	40.71	0.48	41.19	56.00	-14.81	QP
12.424	38.93	0.66	39.59	60.00	-20.41	QP
12.424	31.49	0.66	32.15	50.00	-17.85	AVERAGE
22.766	43.16	0.76	43.92	60.00	-16.08	QP
22.766	37.51	0.76	38.27	50.00	-11.73	AVERAGE

Remarks: 1. Level = Read Level + Factor
 2. Factor = LISN(ISN) Factor + Cable Loss

EUT : 3100
 Power : AC 110V
 Test Mode : 802.11a CH 64
 Memo :

Pol/Phase : LINE
 Temperature : 26 °C
 Humidity : 61 %

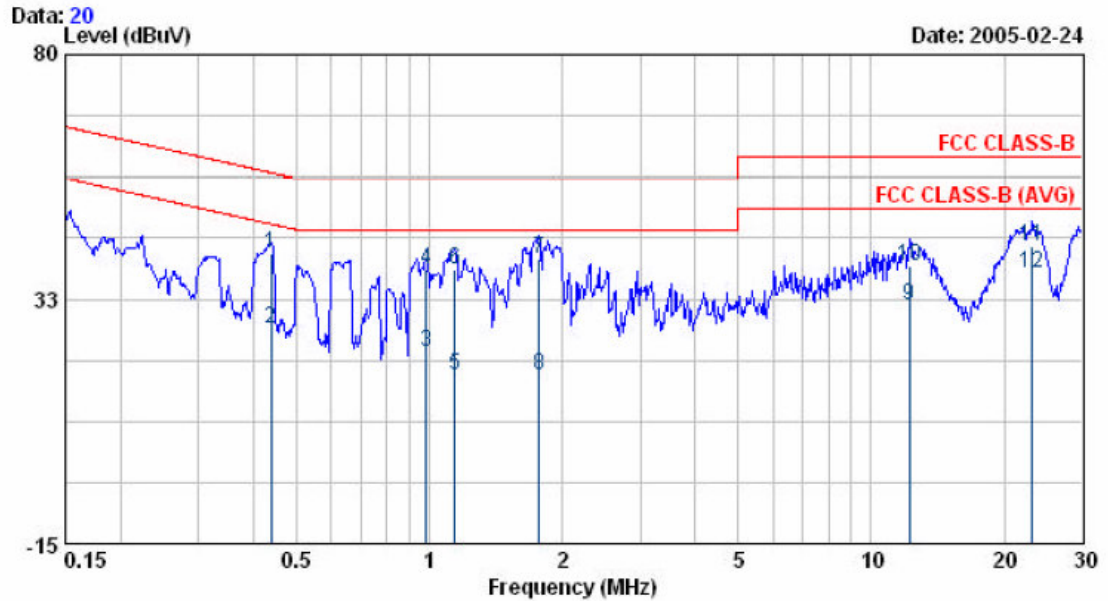

Freq	Read Level	Factor	Level	Limit	Over Limit	Remark
MHz	dBuV	dB	dBuV	dBuV	dBuV	
0.439	40.71	0.49	41.20	57.09	-15.89	QP
0.439	26.41	0.49	26.90	47.09	-20.19	AVERAGE
0.985	21.75	0.40	22.15	46.00	-23.85	AVERAGE
0.985	37.69	0.40	38.09	56.00	-17.91	QP
1.141	17.45	0.42	17.87	46.00	-28.13	AVERAGE
1.141	37.96	0.42	38.38	56.00	-17.62	QP
1.771	39.85	0.48	40.33	56.00	-15.67	QP
1.771	17.36	0.48	17.84	46.00	-28.16	AVERAGE
12.178	30.61	0.59	31.20	50.00	-18.80	AVERAGE
12.178	38.36	0.59	38.95	60.00	-21.05	QP
23.139	41.69	0.96	42.65	60.00	-17.35	QP
23.139	36.68	0.96	37.64	50.00	-12.36	AVERAGE

Remarks: 1. Level = Read Level + Factor
 2. Factor = LISN(ISN) Factor + Cable Loss

EUT : 3100
 Power : AC 110V
 Test Mode : 802.11a CH 149
 Memo :
 Pol/Phase : NEUTRAL
 Temperature : 26 °C
 Humidity : 61 %

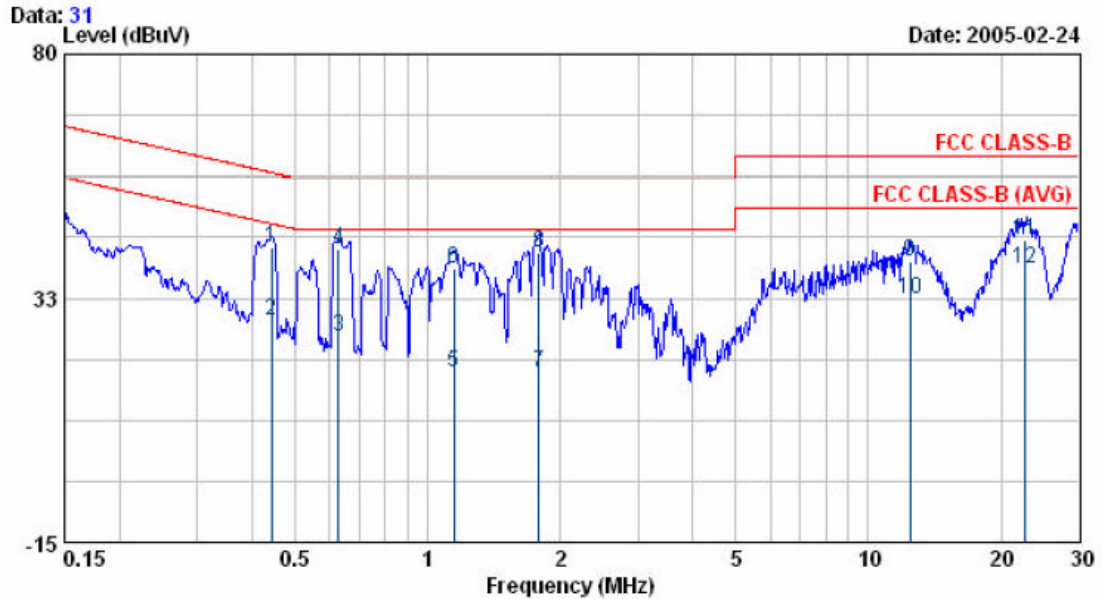

Freq MHz	Read Level dBuV	Factor dB	Level dBuV	Limit dBuV	Over Limit dBuV	Remark
0.441	41.91	0.49	42.40	57.04	-14.64	QP
0.441	27.69	0.49	28.18	47.04	-18.86	AVERAGE
0.628	24.69	0.45	25.14	46.00	-20.86	AVERAGE
0.628	41.63	0.45	42.08	56.00	-13.92	QP
1.146	17.49	0.42	17.91	46.00	-28.09	AVERAGE
1.146	37.73	0.42	38.15	56.00	-17.85	QP
1.786	17.51	0.48	17.99	46.00	-28.01	AVERAGE
1.786	40.78	0.48	41.26	56.00	-14.74	QP
12.424	38.91	0.66	39.57	60.00	-20.43	QP
12.424	31.51	0.66	32.17	50.00	-17.83	AVERAGE
22.766	43.21	0.76	43.97	60.00	-16.03	QP
22.766	37.54	0.76	38.30	50.00	-11.70	AVERAGE

Remarks: 1. Level = Read Level + Factor
 2. Factor = LISN(ISN) Factor + Cable Loss

EUT : 3100
 Power : AC 110V
 Test Mode : 802.11a CH 149
 Memo :

Pol/Phase : LINE
 Temperature : 26 °C
 Humidity : 61 %

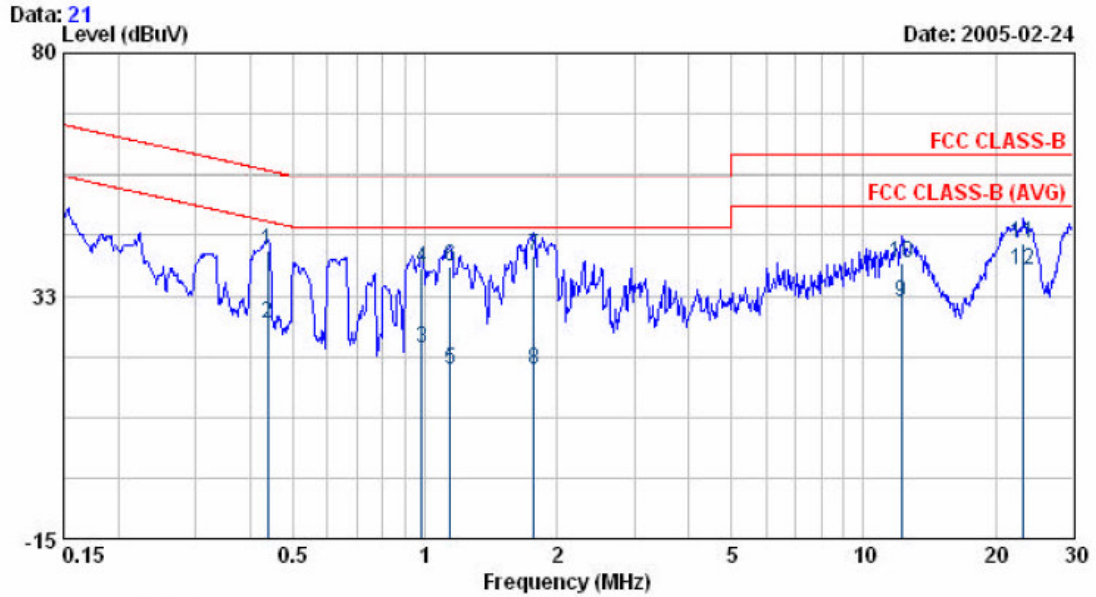

Freq	Read Level	Factor	Level	Limit	Over Limit	Remark
MHz	dBuV	dB	dBuV	dBuV	dBuV	
0.439	40.75	0.49	41.24	57.09	-15.85	QP
0.439	26.45	0.49	26.94	47.09	-20.15	AVERAGE
0.985	21.71	0.40	22.11	46.00	-23.89	AVERAGE
0.985	37.65	0.40	38.05	56.00	-17.95	QP
1.141	17.49	0.42	17.91	46.00	-28.09	AVERAGE
1.141	37.91	0.42	38.33	56.00	-17.67	QP
1.771	39.81	0.48	40.29	56.00	-15.71	QP
1.771	17.41	0.48	17.89	46.00	-28.11	AVERAGE
12.178	30.65	0.59	31.24	50.00	-18.76	AVERAGE
12.178	38.41	0.59	39.00	60.00	-21.00	QP
23.139	41.65	0.96	42.61	60.00	-17.39	QP
23.139	36.69	0.96	37.65	50.00	-12.35	AVERAGE

Remarks: 1. Level = Read Level + Factor
 2. Factor = LISN(ISN) Factor + Cable Loss

EUT : 3100
 Power : AC 110V
 Test Mode : 802.11a CH 161
 Memo :

Pol/Phase : NEUTRAL
 Temperature : 26 °C
 Humidity : 61 %

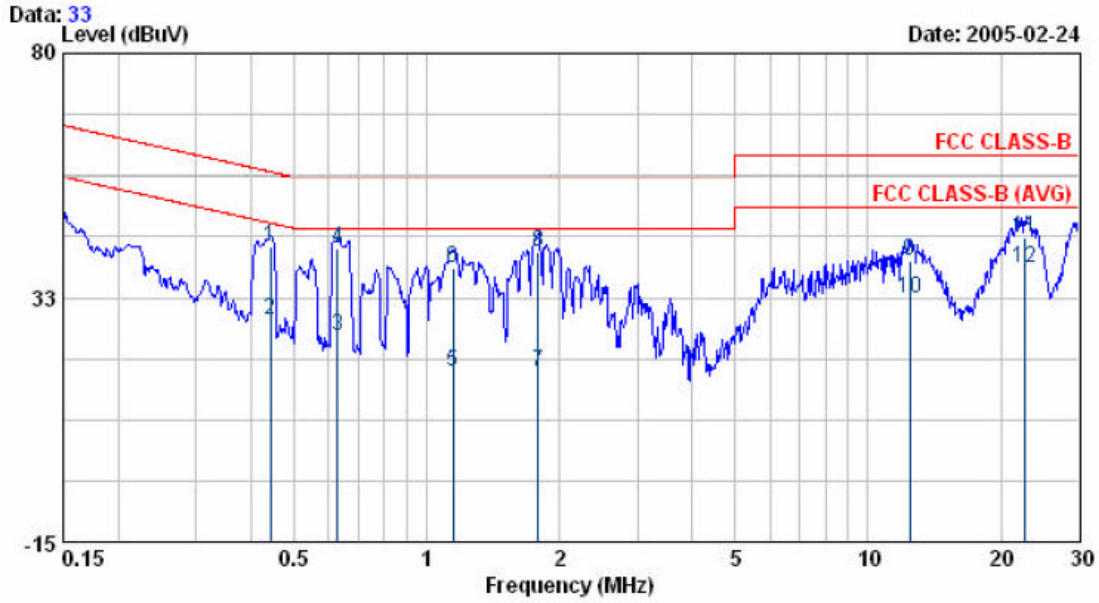

Freq	Read	Factor	Level	Limit	Over	Remark
MHz	dBuV	dB	dBuV	dBuV	dBuV	
0.441	41.93	0.49	42.42	57.04	-14.62	QP
0.441	27.63	0.49	28.12	47.04	-18.92	AVERAGE
0.628	24.61	0.45	25.06	46.00	-20.94	AVERAGE
0.628	41.65	0.45	42.10	56.00	-13.90	QP
1.146	17.51	0.42	17.93	46.00	-28.07	AVERAGE
1.146	37.74	0.42	38.16	56.00	-17.84	QP
1.786	17.69	0.48	18.17	46.00	-27.83	AVERAGE
1.786	40.72	0.48	41.20	56.00	-14.80	QP
12.424	38.93	0.66	39.59	60.00	-20.41	QP
12.424	31.67	0.66	32.33	50.00	-17.67	AVERAGE
22.766	43.28	0.76	44.04	60.00	-15.96	QP
22.766	37.61	0.76	38.37	50.00	-11.63	AVERAGE

Remarks: 1. Level = Read Level + Factor
 2. Factor = LISN(ISN) Factor + Cable Loss

EUT : 3100
 Power : AC 110V
 Test Mode : 802.11a CH 161
 Memo :

Pol/Phase : LINE
 Temperature : 26 °C
 Humidity : 61 %

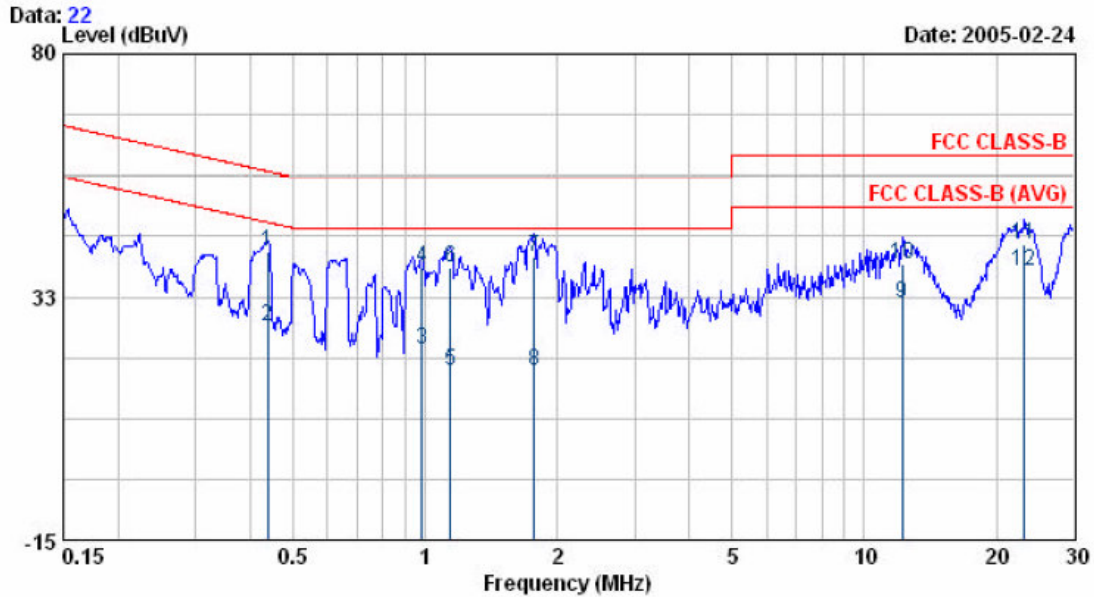

Freq	Read Level	Factor	Level	Limit	Over Limit	Remark
MHz	dBuV	dB	dBuV	dBuV	dBuV	
0.439	40.79	0.49	41.28	57.09	-15.81	QP
0.439	26.41	0.49	26.90	47.09	-20.19	AVERAGE
0.985	21.73	0.40	22.13	46.00	-23.87	AVERAGE
0.985	37.69	0.40	38.09	56.00	-17.91	QP
1.141	17.51	0.42	17.93	46.00	-28.07	AVERAGE
1.141	37.96	0.42	38.38	56.00	-17.62	QP
1.771	39.85	0.48	40.33	56.00	-15.67	QP
1.771	17.46	0.48	17.94	46.00	-28.06	AVERAGE
12.178	30.69	0.59	31.28	50.00	-18.72	AVERAGE
12.178	38.45	0.59	39.04	60.00	-20.96	QP
23.139	41.69	0.96	42.65	60.00	-17.35	QP
23.139	36.53	0.96	37.49	50.00	-12.51	AVERAGE

Remarks: 1. Level = Read Level + Factor
 2. Factor = LISN(ISN) Factor + Cable Loss

Test By: Carol Feb. 24, 2005

5.4.1. Photographs of Conducted Emission Test

Front View



Rear View



6. Test of Radiated Emission

Radiated emissions from 30 MHz to 40 GHz were measured according to the methods defines in ANSI C63.4-2003. The EUT was placed, 0.8 meter above the ground plane, as shown in section 1.4.2. The interface cables and equipment positions were varied within limits of reasonable applications to determine the positions producing maximum radiated emissions

6.1. Test Procedures

1. The EUT was placed on a rotatable table top 0.8 meter above ground.
2. The EUT was set 3 meters from the interference receiving antenna which was mounted on the top of a variable height antenna tower.
3. The table was rotated 360 degrees to determine the position of the highest radiation.
4. The antenna is a broadband antenna and its height is varied between one meter and four meters above ground to find the maximum value of the field strength both horizontal polarization and vertical polarization of the antenna are set to make the measurement.
5. For each suspected emission the EUT was arranged to its worst case and then tune the antenna tower (from 1 M to 4 M) and turn table (from 0 degree to 360 degrees) to find the maximum reading.
6. Set the test-receiver system to Peak or CISPR quasi-peak Detect Function and specified bandwidth with Maximum Hold Mode.
7. If the emission level of the EUT in peak mode was 3 dB lower than the limit specified, then testing will be stopped and peak values of EUT will be reported, otherwise, the emissions which do not have 3 dB margin will be repeated one by one using the quasi-peak method and reported.
8. For testing above 1GHz, the emission level of the EUT in peak mode was 20dB lower than average limit (that means the emission level in peak mode also complies with the limit in average mode), then testing will be stopped and peak values of EUT will be reported, otherwise, the emissions will be measured in average mode again and reported.

6.2. Typical Test Setup Layout of Radiated Emission

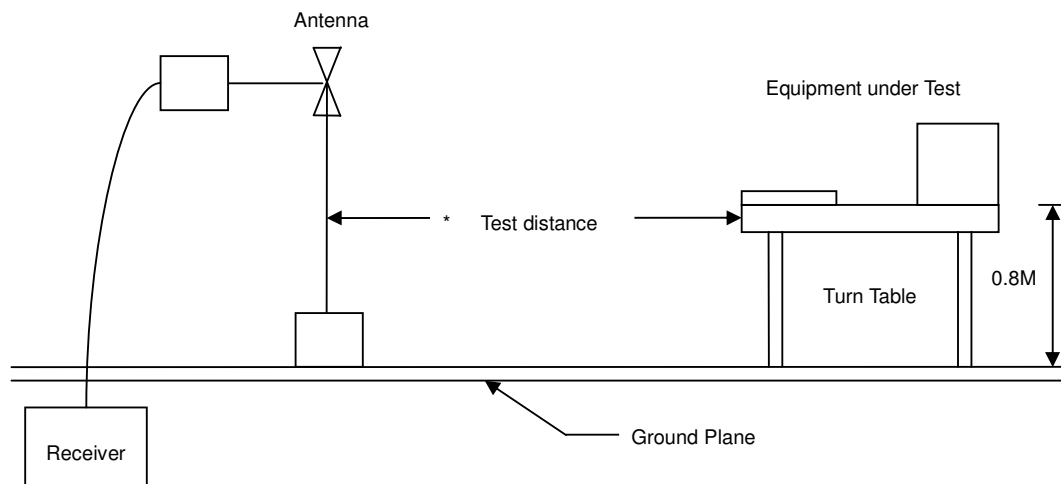

6.3. Test Result of Radiated Emission

Emission frequencies below 1 GHz Channel 01

Test Date: Feb. 17, 2005 Temperature: 23□ Humidity: 69% Atmospheric pressure: 1028mmHg

Frequency (MHz)	Ant-Pol H/V	Meter Reading (dBuV)	Corrected Factor (dB)	Result@3m (dBuV/m)	Limit@3m (dBuV/m)	Margin (dB)	Remark	Table Deg.	Ant High (m)
151.55	H	53.07	-17.17	35.90	43.5	-7.60	Peak	142	1.2
250.03	H	57.38	-13.69	43.69	46.0	-2.31	Q.P	150	1.2
375.60	H	53.39	-10.09	43.30	46.0	-2.70	Q.P	168	1.2
400.02	H	48.90	-9.13	39.77	46.0	-6.23	Peak	146	1.2
933.34	H	46.87	-2.40	44.47	46.0	-4.53	Q.P	275	1.2
55.30	V	54.84	-21.04	33.80	40.0	-6.20	Peak	105	1.1
200.01	V	54.17	-16.71	37.46	43.5	-6.04	Peak	152	1.1
250.00	V	49.69	-13.69	36.00	46.0	-10.00	Peak	154	1.2
375.01	V	53.76	-10.10	43.66	46.0	-2.34	Q.P	164	1.1
400.00	V	53.46	-9.13	44.33	46.0	-1.67	Q.P	147	1.1
500.01	V	48.24	-7.80	40.44	46.0	-5.56	Q.P	151	1.1
933.34	V	44.01	-2.40	41.61	46.0	-4.49	Q.P	272	1.2

Notes:

1. Result = Meter Reading + Corrected Factor
2. Corrected Factor = Antenna Factor + Cable Loss – Amplifier
3. The resolution bandwidth of test receiver/spectrum analyzer is 120 kHz and video bandwidth is 300 kHz for Peak detection and Quasi-peak detection at frequency below 1GHz.
4. The resolution bandwidth of test receiver/spectrum analyzer is 1 MHz and video bandwidth is 3 MHz for Peak detection at frequency above 1GHz.
5. The resolution bandwidth of test receiver/spectrum analyzer is 1MHz and video bandwidth is 10Hz for Average detection at frequency above 1GHz.
6. The other emissions is too below to be measured.

Emission frequencies 1~40 GHz

Test Mode: Normal, Channel 01, Transmit Rate: 6Mbps

Test Date: Feb. 17, 2005 Temperature: 23□ Humidity: 69% Atmospheric pressure: 1028mmHg

Frequency (MHz)	Ant-Pol H/V	Meter Reading (dBuV)	Corrected Factor (dB)	Result@3m (dBuV/m)	Limit@3m (dBuV/m)	Margin (dB)	Remark	Table Deg.	Ant High (m)
1198.00	H	60.43	-5.12	55.31	74.0	-18.69	Peak	143	1.2
1198.00	H	50.32	-5.12	45.20	54.0	-8.80	Ave	143	1.2
10360.00	H	---	15.43	---	68.3	---	Peak	---	---
1198.00	V	63.95	-5.62	58.33	74.0	-15.67	Peak	148	1.1
1198.00	V	53.74	-5.62	48.12	54.0	-5.88	Ave	148	1.1
2430.00	V	52.04	0.69	52.73	68.3	-15.57	Peak	185	1.1
6522.00	V	55.61	9.67	65.28	68.3	-3.02	Peak	146	1.1
9349.00	V	52.84	13.42	66.26	74.0	-7.74	Peak	184	1.1
9349.00	V	38.03	13.42	51.45	54.0	-2.55	Ave	184	1.1
10360.00	V	48.93	14.93	63.86	68.3	-4.44	Peak	187	1.1

Notes:

1. Result = Meter Reading + Corrected Factor
2. Corrected Factor = Antenna Factor + Cable Loss – Amplifier
3. The resolution bandwidth of test receiver/spectrum analyzer is 120 kHz and video bandwidth is 300 kHz for Peak detection and Quasi-peak detection at frequency below 1GHz.
4. The resolution bandwidth of test receiver/spectrum analyzer is 1 MHz and video bandwidth is 3 MHz for Peak detection at frequency above 1GHz.
5. The resolution bandwidth of test receiver/spectrum analyzer is 1MHz and video bandwidth is 10Hz for Average detection at frequency above 1GHz.
6. The other emissions is too below to be measured.

Emission frequencies 1~40 GHz

Test Mode: Normal, Channel 04, Transmit Rate: 6Mbps

Test Date: Feb. 17, 2005 Temperature: 23□ Humidity: 69% Atmospheric pressure: 1028mmHg

Frequency (MHz)	Ant-Pol H/V	Meter Reading (dBuV)	Corrected Factor (dB)	Result@3m (dBuV/m)	Limit@3m (dBuV/m)	Margin (dB)	Remark	Table Deg.	Ant High (m)
1198.00	H	61.17	-5.12	55.05	74.0	-17.95	Peak	152	1.2
1198.00	H	51.22	-5.12	46.10	54.0	-7.90	Ave	152	1.2
10480.00	H	---	15.78	---	68.3	---	Peak	---	---
5917.00	V	56.37	9.37	65.74	68.3	-2.56	Peak	191	1.1
1198.00	V	64.15	-5.62	58.53	74.0	-15.47	Peak	157	1.1
1198.00	V	54.20	-5.62	48.58	54.0	-5.42	Ave	157	1.1
9338.00	V	54.12	13.42	67.54	74.0	-6.46	Peak	182	1.1
9338.00	V	38.47	13.42	51.89	54.0	-2.21	Ave	182	1.1
10482.00	V	50.41	15.28	65.69	68.3	-2.61	Peak	184	1.1

Notes:

1. Result = Meter Reading + Corrected Factor
2. Corrected Factor = Antenna Factor + Cable Loss – Amplifier
3. The resolution bandwidth of test receiver/spectrum analyzer is 120 kHz and video bandwidth is 300 kHz for Peak detection and Quasi-peak detection at frequency below 1GHz.
4. The resolution bandwidth of test receiver/spectrum analyzer is 1 MHz and video bandwidth is 3 MHz for Peak detection at frequency above 1GHz.
5. The resolution bandwidth of test receiver/spectrum analyzer is 1MHz and video bandwidth is 10Hz for Average detection at frequency above 1GHz.
6. The other emissions is too below to be measured.