



FCC TEST REPORT

for

47 CFR Part 15 Subpart C

Equipment : Multi Radio 802.11a/b/g/n Wireless LAN Access Point
Trade Name : Meru Networks Inc.
Model No. : AP310, AP311, AP320
FCC ID : RE7-AP300
Filing Type : Certification
Applicant : Meru Networks Inc.
894 Ross Drive Sunnyvale, CA 94089 USA

- The test result refers exclusively to the test presented test model / sample.
- Without written approval of SPORTON International Inc., the test report shall not be reproduced except in full.
- **Certificate or Test Report must not be used by the applicant to claim the product in this test report endorsement by NVLAP or any agency of U.S. government.**
- The data shown in this test report were carried out on Oct. 01, 2007 at **Sporton International Inc. LAB.**
- Report No.: FR791302A, Report Version: Rev.02

Jones Tsai
Manager

SPORTON International Inc.

6F, No.106, Sec. 1, Hsin Tai Wu Rd., Hsi Chih, Taipei Hsien, Taiwan, R.O.C.



Table of Contents

History of this test report.....ii

1. General Description of Equipment under Test..... 1

 1.1 Applicant1

 1.2 Manufacturer1

 1.3 Basic Description of Equipment under Test.....1

 1.4 Feature of Equipment under Test2

2 Test Configuration of Equipment under Test3

 2.1 Test Manner3

 2.2 Test Mode5

 Note: 1. In the EUT, there are two identical WLAN modules which separately use six same dipole antennas5

 Ancillary Equipment List.....6

 2.3 Connection Diagram of Test System6

3. RF Utility8

4. General Information of Test.....9

 4.1 Test Voltage9

 4.2 Standard for Methods of Measurement.....9

 4.3 Test Compliance9

 4.4 Frequency Range.....9

 4.5 Test Distance9

5. Test Data and Test Result.....10

 5.1 List of Measurements and Examinations10

 5.2 6dB Bandwidth Measurement11

 5.3 Power Spectral Density Measurement.....32

 5.4 Band Edges Measurement.....54

 5.5 Peak Output Power Measurement73

 5.6 Conducted Emission75

 5.7 Radiated Emission Measurement80

 5.8 Antenna Requirements174

6. List of Measuring Equipments Used175

7. Uncertainty Evaluation.....176

Appendix A. Photographs of EUT External

Appendix B. Photographs of EUT Internal

Appendix C. Photographs of Setup



1. General Description of Equipment under Test

1.1 Applicant

Meru Networks Inc.
894 Ross Drive Sunnyvale, CA 94089 USA

1.2 Manufacturer

Universal Scientific Industrial (Shanghai)
No. 1558, Zhang Dong Road, Zhangjiang Hi-Tech Park, Shanghai, P.R. China 201203

1.3 Basic Description of Equipment under Test

Equipment		Multi Radio 802.11a/b/g/n Wireless LAN Access Point
Trade Name		Meru Networks Inc.
Model No.		AP310, AP311, AP320
FCC ID		RE7-AP300
Antenna 1	Model Name	MRU04-220050
	Antenna Gain	2 dBi(2.4G), 3 dBi(5G)
	Antenna Type	Dipole antenna
	Connector	Reverse SMA
Antenna 2	Model Name	ANT-DB1-RAF-RPS
	Antenna Gain	4.7 dBi for 2.4G and 5GHz band.
	Antenna Type	Dipole antenna
	Connector	Reverse SMA
POE	Model Name	POE-152
	Power Rating	I/P:DC48V, 0.4A
AC Adapter 1	Brand Name	UMEC
	Model Name	UP0251P-05PA
	Power Rating	I/P:100-240Vac,50-60Hz,0.5A; O/P:5V,3.5A
	AC Power Cord Type	1.9 meter non-shielded cable without ferrite core
AC Adapter 2	Brand Name	UMEC
	Model Name	UP0151D-48P
	Power Rating	I/P:100-240V,47-63Hz,0.4A; O/P:48V,0.32A
	AC Power Cord Type	0.8 meter shielded cable with ferrite core

Remark: Above EUT's information was declared by manufacturer. Please refer to the specifications of manufacturer or User's Manual for more detailed features description.



1.4 Feature of Equipment under Test

Product Feature & Specification			
1.	Type of Modulation	DSSS / OFDM	
2.	Number of Channels	802.11a : 5 Channels (Band III) 802.11b/g : 11 Channels 802.11n : 5 channels (149-165 Channel number),	
3.	Frequency Band	802.11a : 5725MHz ~ 5850MHz (Band III) 802.11b/g : 2400MHz ~ 2483.5MHz 802.11n : 5725MHz ~ 5850MHz (Band III)	
4.	Nominal Bandwidth	20MHz mode and 40MHz mode	
5.	Maximum Output Power to Antenna (Normal Condition)	802.11a : 21.95 dBm 802.11b : 17.01 dBm 802.11g : 21.84 dBm 802.11n(g) : 25.66 dBm (BW 20M) / 23.56 dBm (BW 40M) 802.11n(a) : 26.64 dBm (BW 20M) / 23.34 dBm (BW 40M)	
6.	Type of Antenna Connector	Reverse SMA connector	
7.	Antenna Type	Dipole antenna	
8.	Antenna Gain	4.7 dBi	
9.	Function Type	Transmitter	Transceiver V



2 Test Configuration of Equipment under Test

2.1 Test Manner

- a. The EUT has been associated with peripherals pursuant to ANSI C63.4-2003 and configuration operated in a manner tended to maximize its emission characteristics in a typical application.
- b. Power table for each modes are as below:

802.11b

Channel	Frequency (MHz)	Data Rate (Mbps)			
		1	2	5.5	11
CH 01	2412 MHz	16.86	16.46	16.16	16.18
CH 06	2437 MHz	16.81	16.72	16.79	16.68
CH 11	2462 MHz	16.98	16.97	17.01	16.95

802.11g

Channel	Frequency (MHz)	Data Rate (Mbps)							
		6	9	12	18	24	36	48	54
CH 01	2412 MHz	21.18	21.1	21.51	21.32	20.94	20.97	21.04	20.92
CH 06	2437 MHz	21.53	21.01	21.22	21.23	21.22	21.64	20.57	21.75
CH 11	2462 MHz	21.12	21.41	21.27	21.17	21.11	21.25	21.84	21.84

802.11a

Channel	Frequency (MHz)	Data Rate (Mbps)							
		6	9	12	18	24	36	48	54
CH 149	5745 MHz	21.2	21.37	21.52	21.62	21.65	21.63	21.44	21.74
CH 157	5785 MHz	21.32	21.54	21.55	22.03	21.91	21.9	21.54	21.75
CH 165	5825 MHz	21.79	21.57	21.51	21.6	21.65	21.52	21.75	21.95

802.11n(g) (20M)

Channel	Frequency (MHz)	Data Rate (Mbps)								
		130	117	104	78	52	39	26	13	6.5
CH 01	2412 MHz	24.24	23.36	23.32	23.32	22.96	23.65	23.32	23.41	24.55
CH 06	2437 MHz	23.79	22.85	23.62	23.42	23.37	23.68	23.46	23.7	25.13
CH 11	2462 MHz	23.73	23.14	23.49	23.55	23.23	23.25	23.31	23.42	25.66



802.11n(g) (40M)

Channel	Frequency (MHz)	Data Rate (Mbps)								
		270	243	216	162	108	81	54	27	13.5
CH 03	2422 MHz	21.71	22.03	21.79	21.6	21.42	22.23	22.17	21.96	23.56
CH 09	2452 MHz	22.65	21.63	21.65	21.66	21.08	21.87	21.63	22.16	22.73

802.11n(a) (20M)

Channel	Frequency (MHz)	Data Rate (Mbps)								
		130	117	104	78	52	39	26	13	6.5
CH 149	5745 MHz	24.63	24.33	24.66	25.12	24.32	24.75	24.68	24.84	25.76
CH 157	5785 MHz	25.03	24.74	25.09	24.94	24.75	24.8	25.14	25.99	25.49
CH 165	5825 MHz	24.87	24.84	24.9	25.26	24.94	24.99	24.95	25.99	26.64

802.11n(a) (40M)

Channel	Frequency (MHz)	Data Rate (Mbps)								
		270	243	216	162	108	81	54	27	13.5
CH 151	5755 MHz	23.07	22.89	22.16	22.07	22.37	21.96	22.08	22.14	23.34
CH 159	5795 MHz	22.1	22.2	22.14	22.1	22.12	22.78	22.16	22.33	23.23

c. The highest RF output power's test modes were chosen for testing .



2.2 Test Mode

Application			
Radiated Emission	802.11b	802.11g	802.11a
	Mode 1: CH01_2412 MHz	Mode 4: CH01_2412 MHz	Mode 7: CH149_5745MHz
	Mode 2: CH06_2437 MHz	Mode 5: CH06_2437 MHz	Mode 8: CH157_5785MHz
	Mode 3: CH11_2462 MHz	Mode 6: CH11_2462 MHz	Mode 9: CH165_5825MHz
	802.11n(g)	802.11n(a)	Co-location
	Mode 10: CH01_2412 MHz(BW 20M)	Mode 16: CH149_5745MHz(BW 20M)	Mode 22: 11n(g) CH11(BW 20M) +
	Mode 11: CH06_2437 MHz(BW 20M)	Mode 17: CH157_5785MHz(BW 20M)	11n(g) CH03 (BW 40M)
	Mode 12: CH11_2462 MHz(BW 20M)	Mode 18: CH165_5825MHz(BW 20M)	Mode 23: 11n(a) CH149(BW 20M) +
	Mode 13: CH03_2422 MHz(BW 40M)	Mode 19: CH151_5755MHz(BW 40M)	11n(a) CH165 (BW 20M)
	Mode 14: CH09_2452 MHz(BW 40M)	Mode 20: CH159_5795MHz(BW 40M)	
Mode 15: CH03_2422 MHz(BW 40M)(Module 2)	Mode 21: CH165_5825MHz(BW 20M)(Module 2)		
Conducted Emission	Mode 1: WLAN Link + LAN + Adapter		
	Mode 2: WLAN Link + POE + LAN + Adapter		

- Note: 1. In the EUT, there are two identical WLAN modules which separately use six same dipole antennas .
2. The module 1 was chosen to be tested for full test modes,and then the module 2 was tested based on the module 1 's worst .
3. Only the two modules act same application mode, then the EUT can transmit simultaneously; the worst case for co-location were mode 22 and 23.
4. Test configurations for antenna mode and bandwidth mode :

Antenna Mode	Single (Tx)		Three (Tx)	
	20MHz	40MHz	20MHz	40MHz
802.11b	V	X	X	X
802.11g	V	X	X	X
802.11n(g)	X	X	V	V
802.11a (5725~5850MHz)	V	X	X	X
802.11n (5725~5850MHz)	X	X	V	V

Ancillary Equipment List

Item	Equipment	Trade Name	Model Name	FCC ID	Power Cord/Data cable
1.	NOTEBOOK	DELL	D400	E2K24GBRL	1.2m
2.	iPod	Apple	A1199	DoC	1.2m
3.	Mouse	State	MS-303	DoC	1.2m
4.	WLAN AP	SMC	SMC-100	HEDWG4005ACC	1.8m

2.3 Connection Diagram of Test System

<Radiated Emission >

WLAN

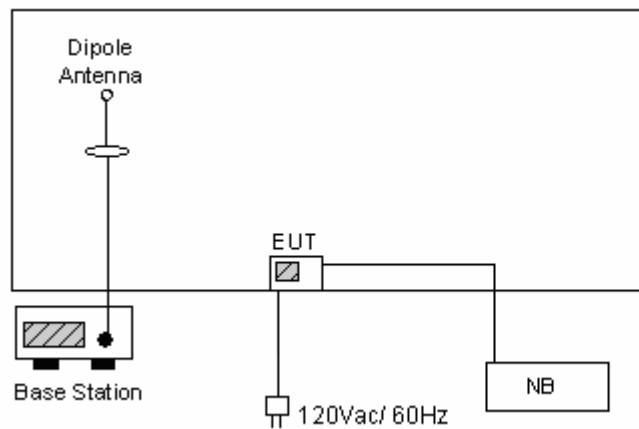

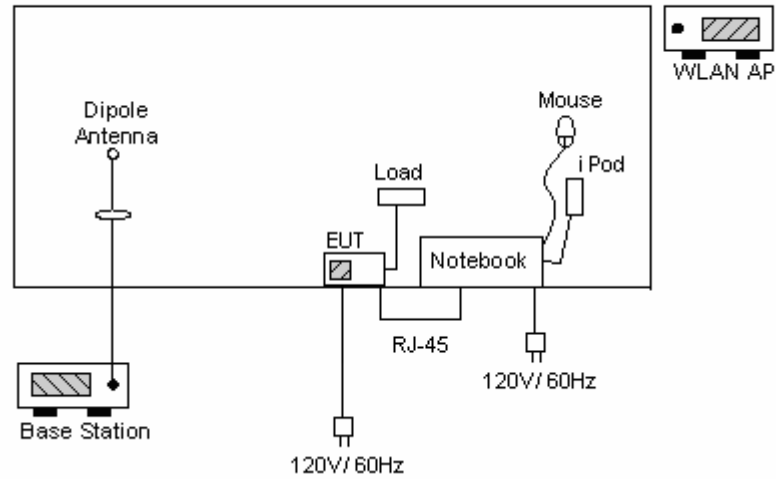
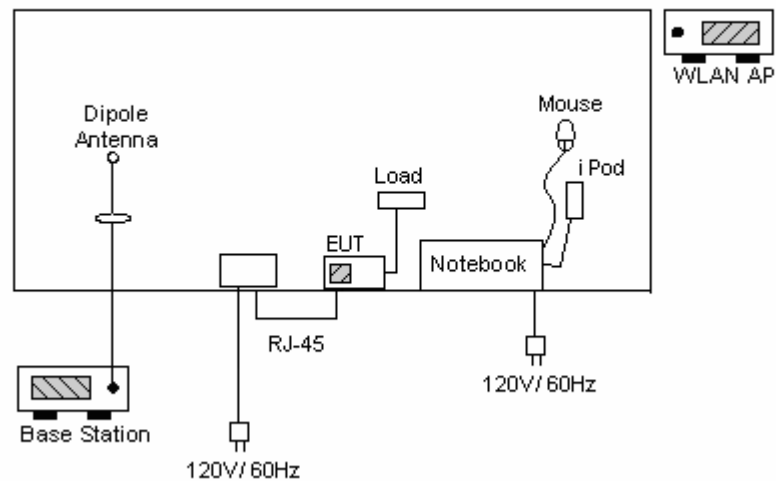
< Conducted Emission >**Mode 1****Mode 2**



3. RF Utility

The programmed RF Utility is installed in EUT to provide channel selection, power level, data rate and the application type. RF Utility can send transmitting signal for all testings.



4. General Information of Test

Test Site Location : No. 52, Hwa Ya 1st Rd., Hwa Ya Technology Park,
Kwei-Shan Hsiang, Tao Yuan Hsien, Taiwan, R.O.C.
TEL : 886-3-327-3456
FAX : 886-3-318-0055

Test Site No : CO04-HY, 03CH04-HY

4.1 Test Voltage

120V/ 60Hz

4.2 Standard for Methods of Measurement

ANSI C63.4-2003

4.3 Test Compliance

47 CFR Part 15 Subpart C

4.4 Frequency Range

- a. Conduction: from 150 kHz to 30 MHz
- b. Radiation: from 30 MHz to 25000 MHz

4.5 Test Distance

The test distance of radiated emission from antenna to EUT is 3 m.



5. Test Data and Test Result

5.1 List of Measurements and Examinations

The Emission Mode: Wireless LAN

FCC Rule	Description of Test	Result
15.207	Conducted Emission	Pass
15.247(a)(2)	6dB & 20dB Bandwidth	Pass
15.247(b)	Maximum Peak Output Power	Pass
15.209(a)	Radiated Emission	Pass
15.247(c)	100kHz Bandwidth of Frequency Band Edges	Pass
15.247(d)	Power Spectral Density	Pass
15.203 15.247(b)(4)	Antenna Requirement	Pass

5.2 6dB Bandwidth Measurement

5.2.1 Measuring Instruments :

As described in chapter 6 of this test report.

5.2.2 Test Procedure :

1. The transmitter output was connected to the spectrum analyzer directly.
2. Set RBW of spectrum analyzer to 100kHz and VBW to 100kHz.
3. The 6 dB bandwidth is defined as the frequency range where the power is higher than the peak power minus 6dB.

5.2.3 Test Setup Layout :

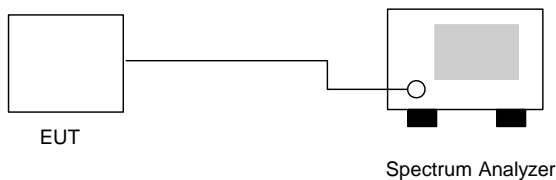

5.2.4 Test Result :

Application Type : WLAN 802.11b/g

Temperature : 25~26°C

Relative Humidity : 51~53%

Test Engineer : Sun

802.11b

Channel	Frequency (MHz)	6dB Emission bandwidth (MHz)	Limits (MHz)	Plot Ref. No.
01	2412	12.37	> 0.5MHz	Mode 1
06	2437	12.40	> 0.5MHz	Mode 2
11	2462	12.28	> 0.5MHz	Mode 3

802.11g

Channel	Frequency (MHz)	6dB Emission bandwidth (MHz)	Limits (MHz)	Plot Ref. No.
01	2412	16.47	> 0.5MHz	Mode 4
06	2437	16.47	> 0.5MHz	Mode 5
11	2462	16.47	> 0.5MHz	Mode 6

**802.11a**

Channel	Frequency (MHz)	6dB Emission bandwidth (MHz)	Limits (MHz)	Plot Ref. No.
149	5745	16.44	> 0.5MHz	Mode 7
157	5785	16.44	> 0.5MHz	Mode 8
165	5825	16.52	> 0.5MHz	Mode 9

802.11n(g)_ BW 20M

Channel	Frequency (MHz)	6dB Emission bandwidth (MHz)	Limits (MHz)	Plot Ref. No.
01	2412	16.92	> 0.5MHz	Mode 10
06	2437	17.08	> 0.5MHz	Mode 11
11	2462	17.32	> 0.5MHz	Mode 12

802.11n(g)_ BW 40M

Channel	Frequency (MHz)	6dB Emission bandwidth (MHz)	Limits (MHz)	Plot Ref. No.
03	2422	35.84	> 0.5MHz	Mode 13
09	2452	36.40	> 0.5MHz	Mode 14

802.11n(a)_ BW 20M

Channel	Frequency (MHz)	6dB Emission bandwidth (MHz)	Limits (MHz)	Plot Ref. No.
149	5745	17.16	> 0.5MHz	Mode 15
159	5785	17.08	> 0.5MHz	Mode 16
165	5825	17.32	> 0.5MHz	Mode 17

802.11n(a)_ BW 40M

Channel	Frequency (MHz)	6dB Emission bandwidth (MHz)	Limits (MHz)	Plot Ref. No.
151	5755	36.40	> 0.5MHz	Mode 18
159	5795	36.40	> 0.5MHz	Mode 19



5.2.5 6dB Bandwidth

Mode 1



* RBW 100 kHz Delta 2 [T1]
 * VBW 100 kHz -0.49 dB
 * Att 30 dB * SWT 500 ms 12.371794872 MHz
 Ref 30 dBm Offset 27.4 dB

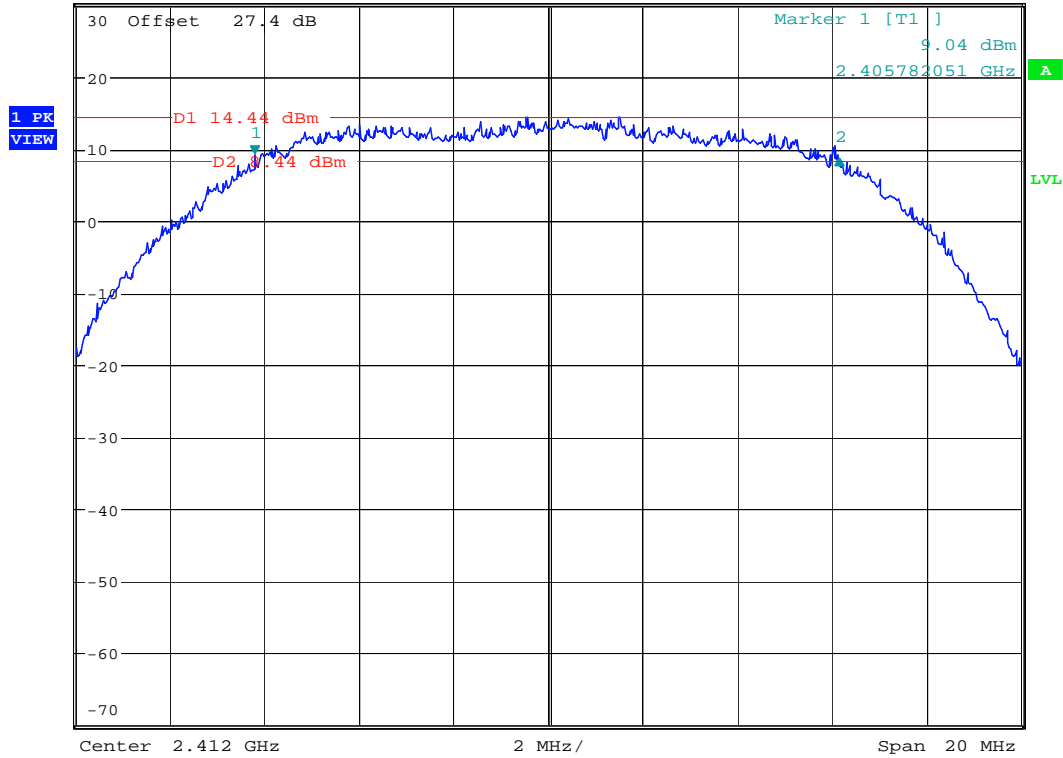

444

Date: 25.SEP.2007 21:55:08



Mode 2



*RBW 100 kHz Delta 2 [T1]
 *VBW 100 kHz 0.14 dB
 *SWT 500 ms 12.403846154 MHz

Ref 30 dBm

*Att 30 dB

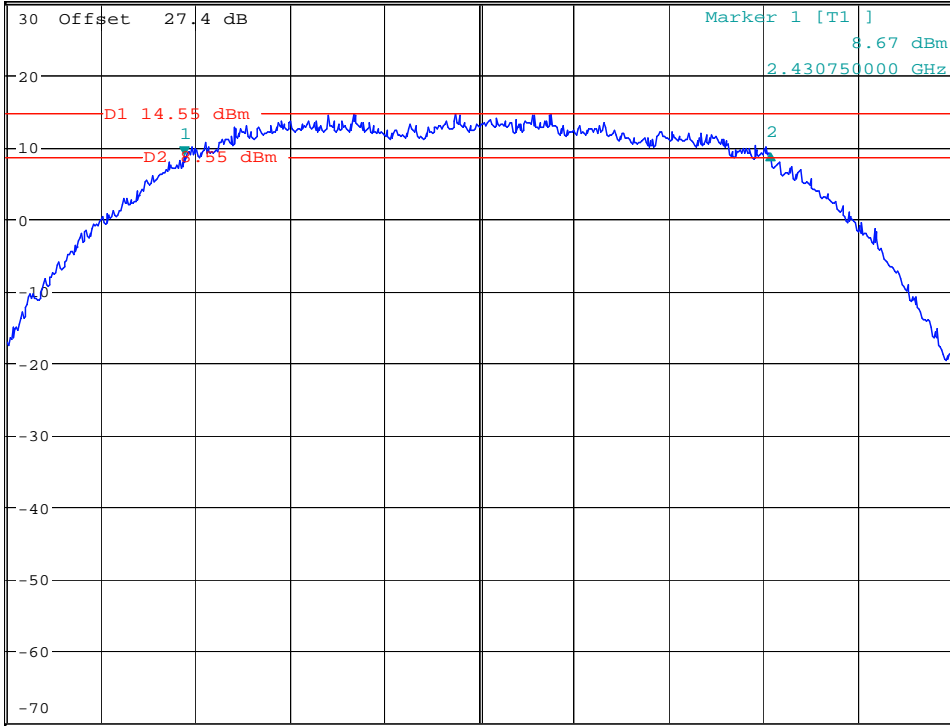

Center 2.437 GHz 2 MHz/ Span 20 MHz

444

Date: 25.SEP.2007 21:46:54



Mode 3



*RBW 100 kHz Delta 2 [T1]
*VBW 100 kHz 0.58 dB
*SWT 500 ms 12.275641026 MHz

Ref 30 dBm

*Att 30 dB

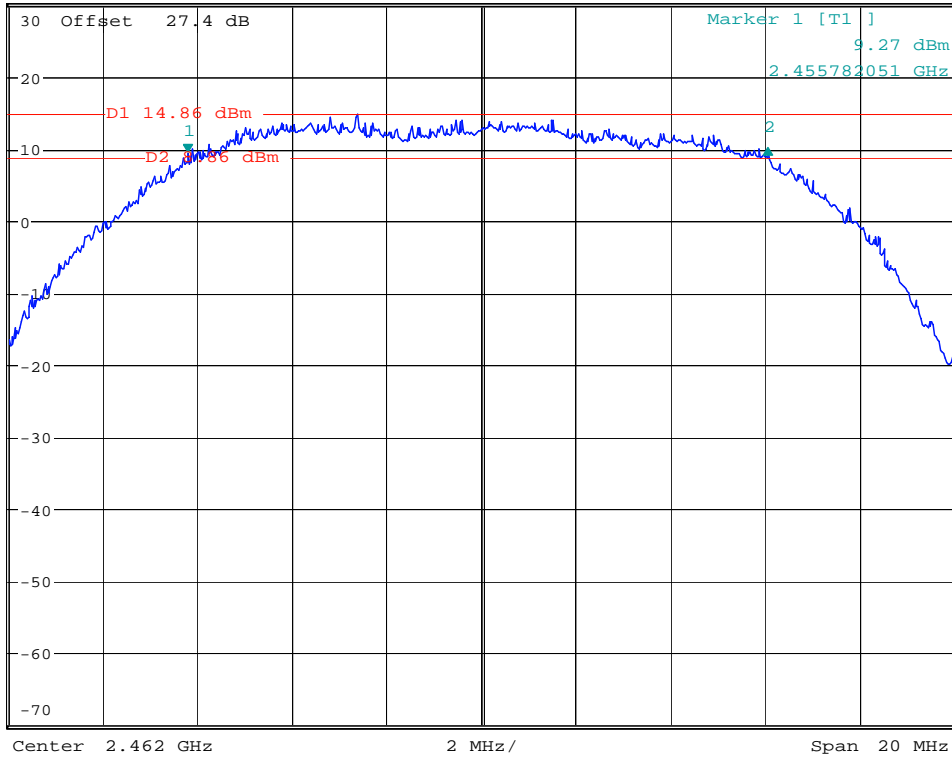

444

Date: 25.SEP.2007 21:44:37



Mode 4



Ref 20 dBm *Att 30 dB *RBW 100 kHz Delta 2 [T1]
 *VBW 100 kHz 0.08 dB
 *SWT 500 ms 16.474358974 MHz

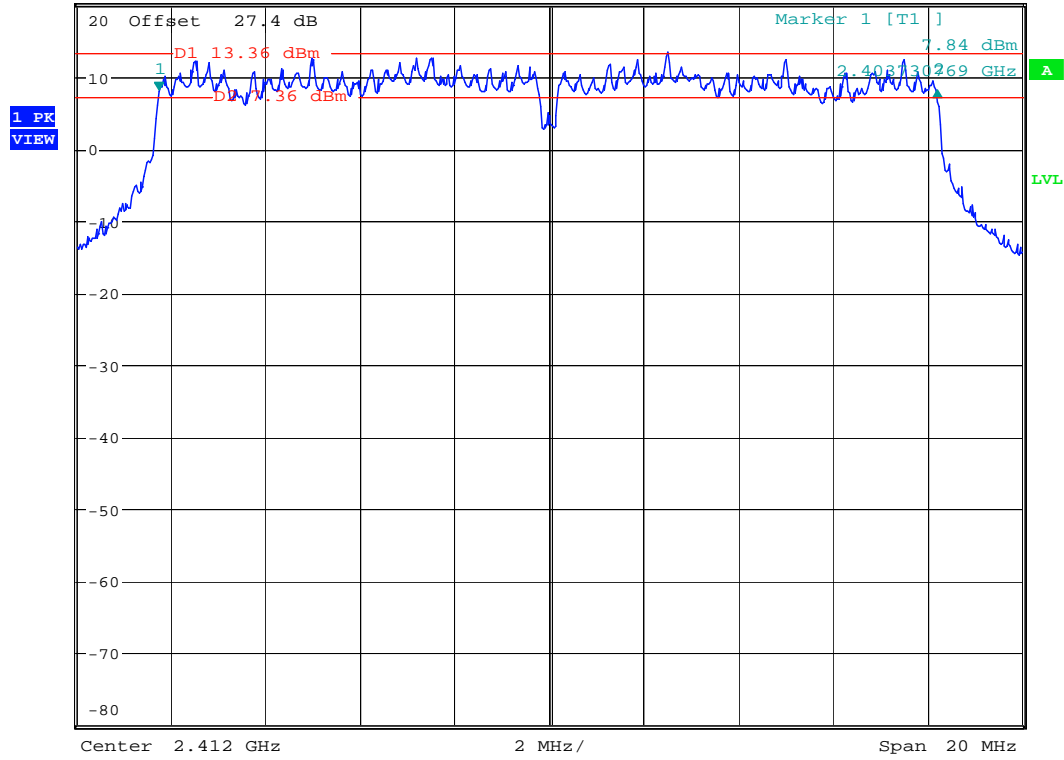

444

Date: 25.SEP.2007 20:40:21



Mode 5

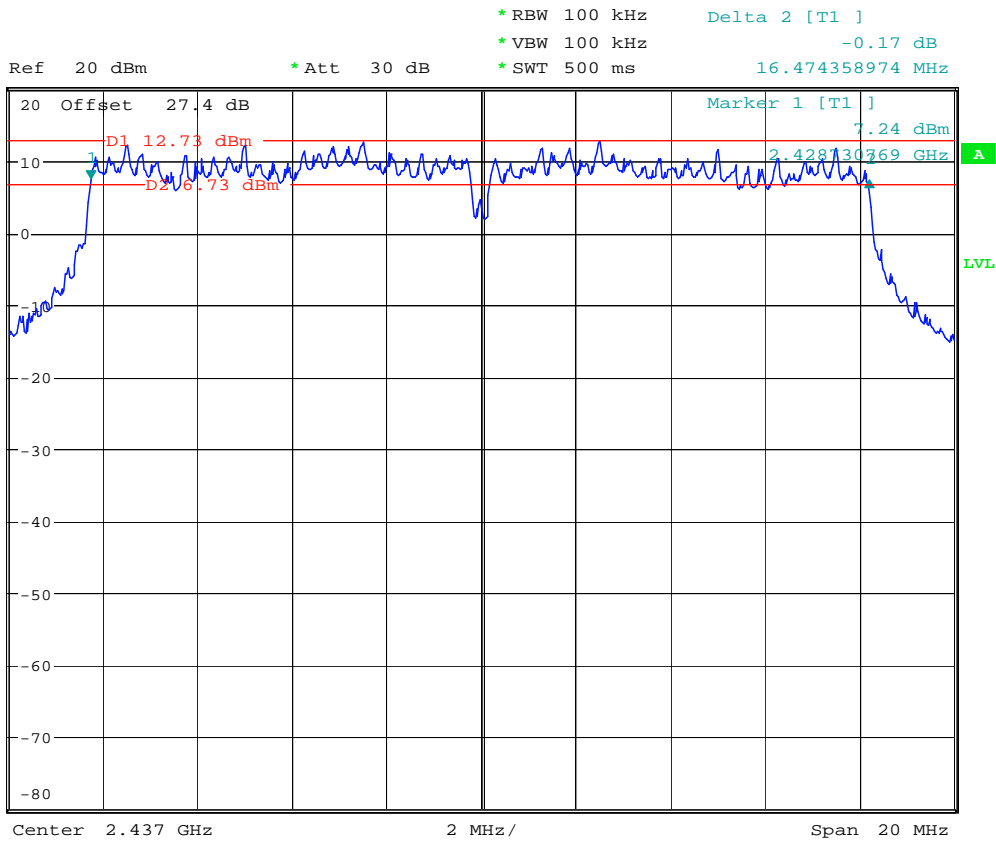

444

Date: 25.SEP.2007 20:42:30



Mode 6



*RBW 100 kHz Delta 2 [T1]
 *VBW 100 kHz -0.54 dB
 *SWT 500 ms 16.474358974 MHz

Ref 20 dBm

*Att 30 dB

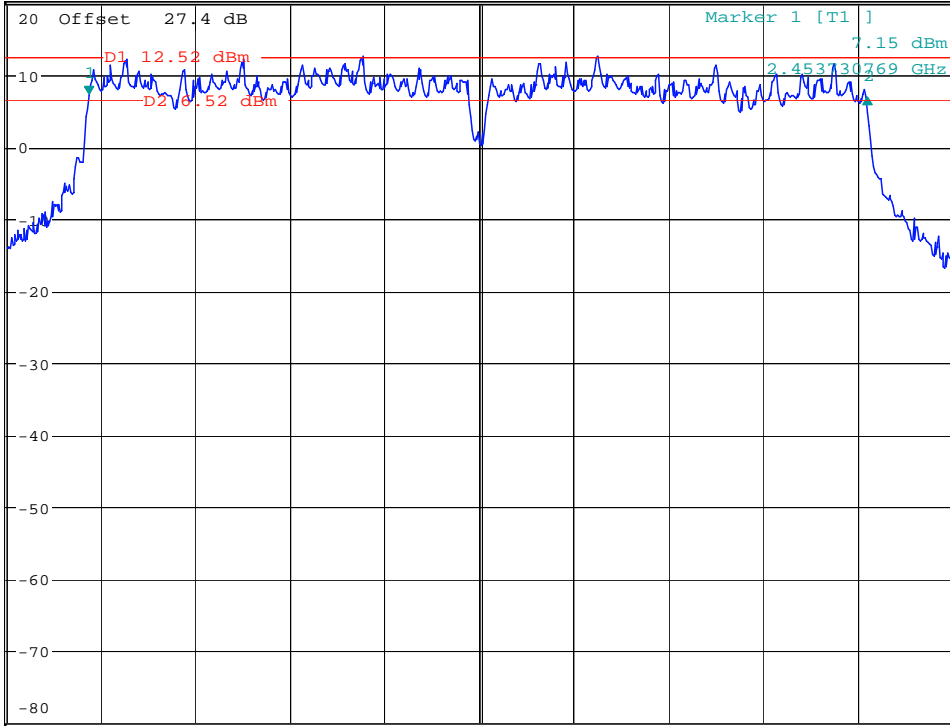

Center 2.462 GHz 2 MHz/ Span 20 MHz

444

Date: 25.SEP.2007 20:44:29



Mode 7



Ref 20 dBm *Att 20 dB *RBW 100 kHz Delta 2 [T1]
*VBW 100 kHz -0.34 dB
*SWT 500 ms 16.440000000 MHz

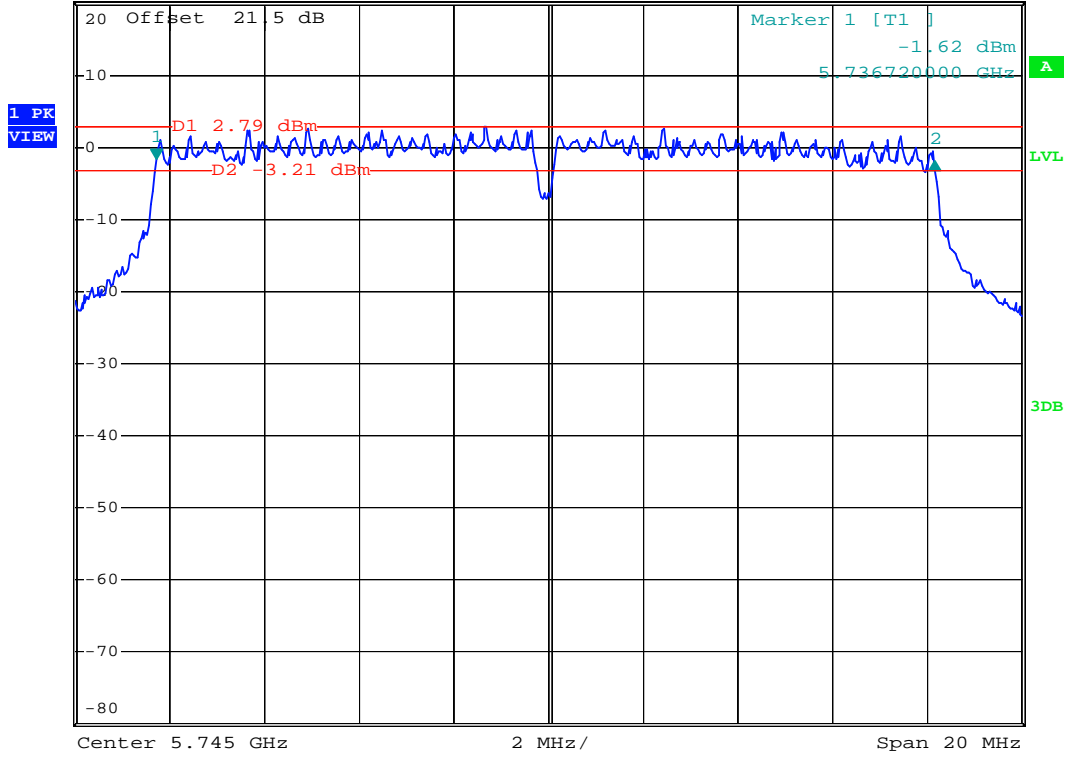

Date: 2.OCT.2007 11:47:08



Mode 8



Ref 20 dBm *Att 20 dB *RBW 100 kHz Delta 2 [T1]
*VBW 100 kHz 0.39 dB
*SWT 500 ms 16.440000000 MHz

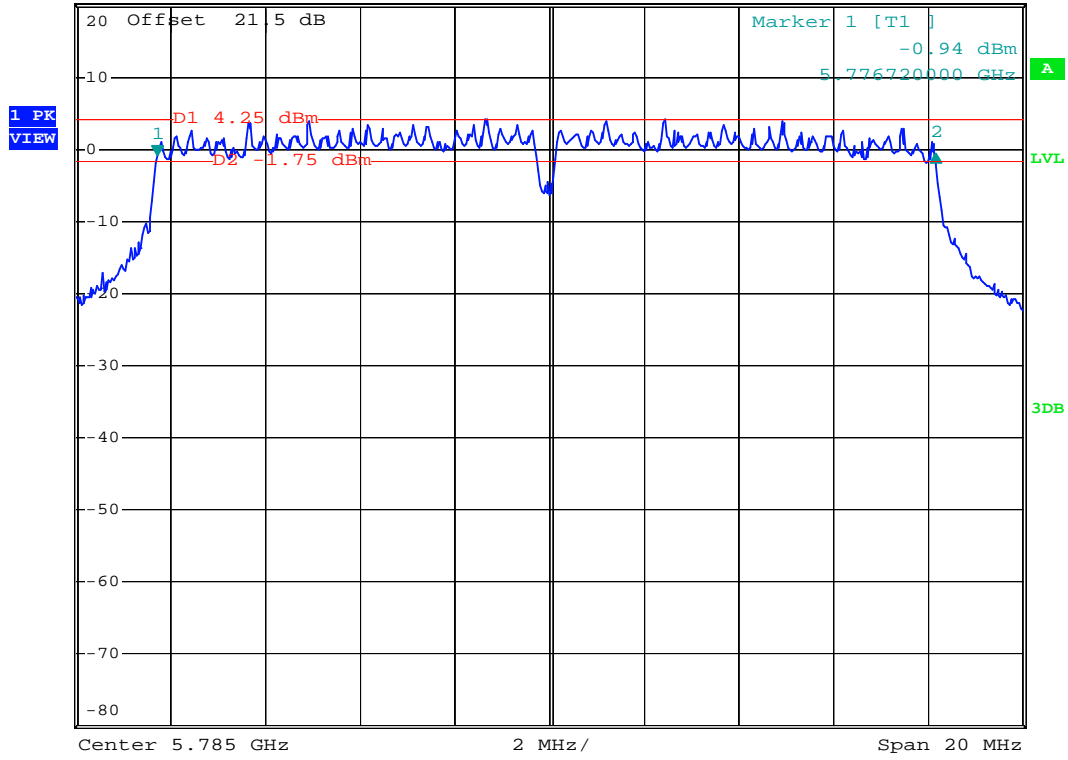

Date: 2.OCT.2007 15:53:48



Mode 9



Ref 20 dBm *Att 20 dB *RBW 100 kHz Delta 2 [T1]
*VBW 100 kHz 0.49 dB
*SWT 500 ms 16.520000000 MHz

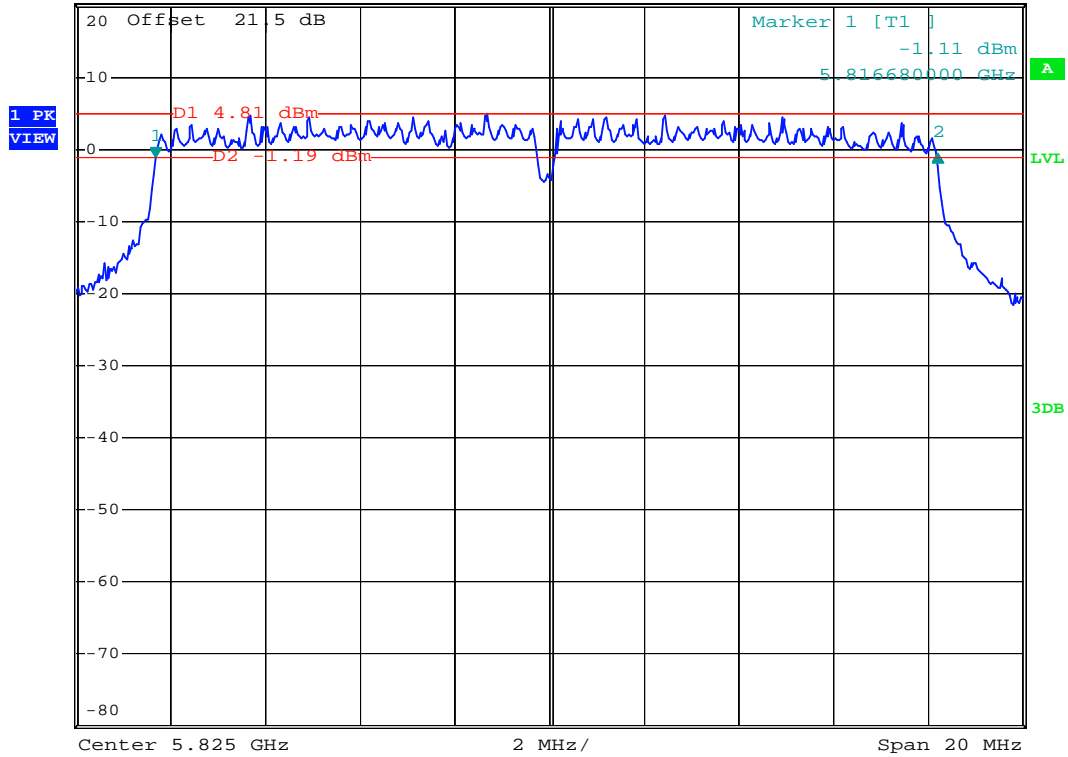

Date: 2.OCT.2007 12:18:11



Mode 10



Ref 30 dBm *Att 30 dB *RBW 100 kHz Delta 2 [T1]
*VBW 100 kHz 0.01 dB
*SWT 500 ms 16.920000000 MHz

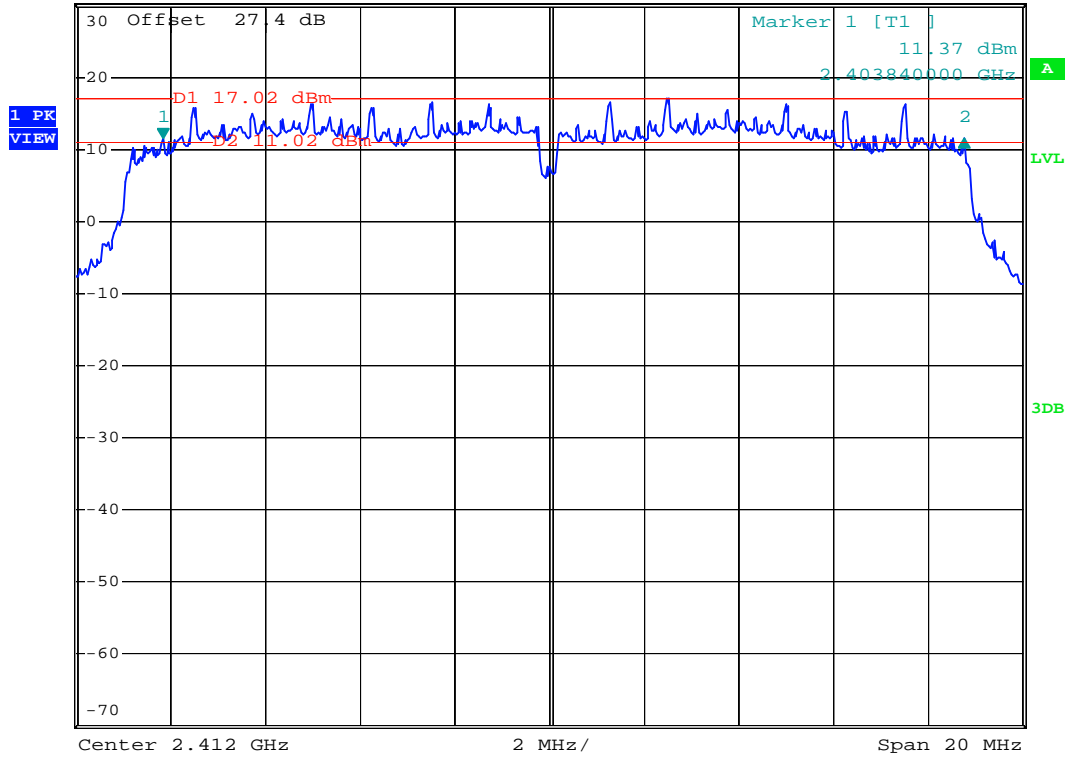

Date: 2.OCT.2007 17:03:12



Mode 11

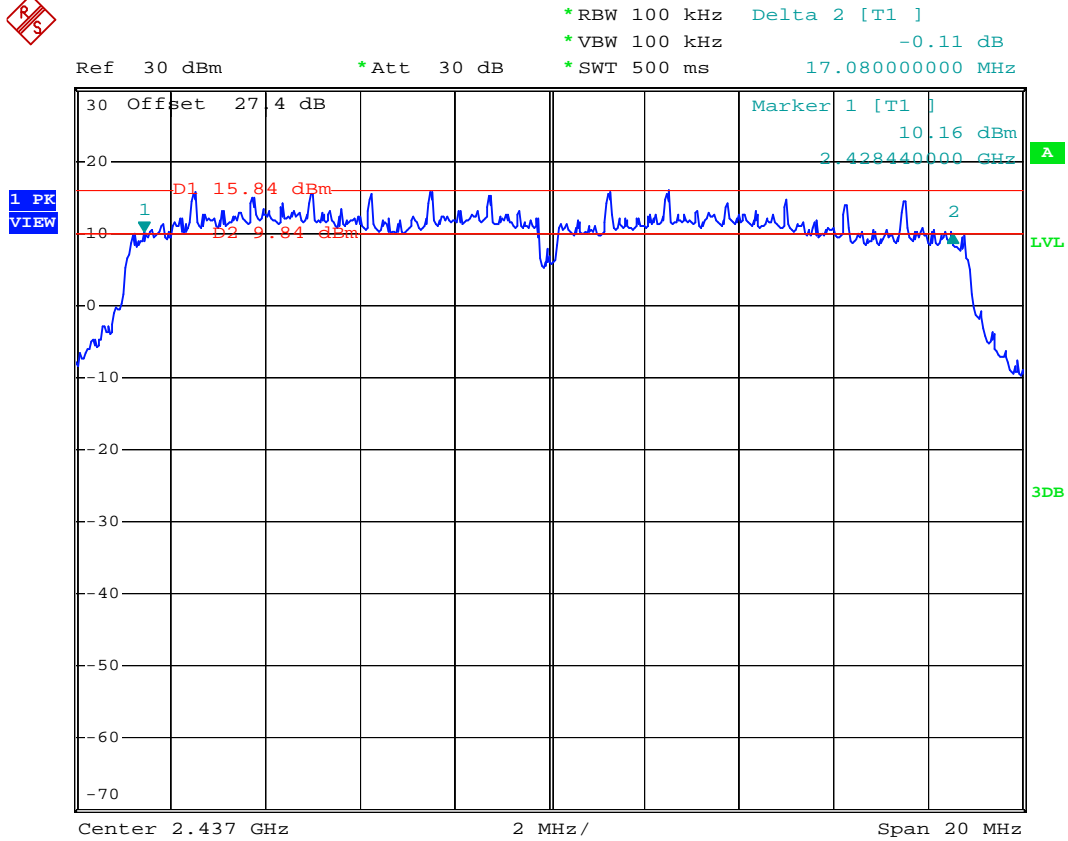

Date: 2.OCT.2007 17:04:53



Mode 12



Ref 30 dBm *Att 30 dB *RBW 100 kHz Delta 2 [T1]
*VBW 100 kHz 0.09 dB
*SWT 500 ms 17.320000000 MHz

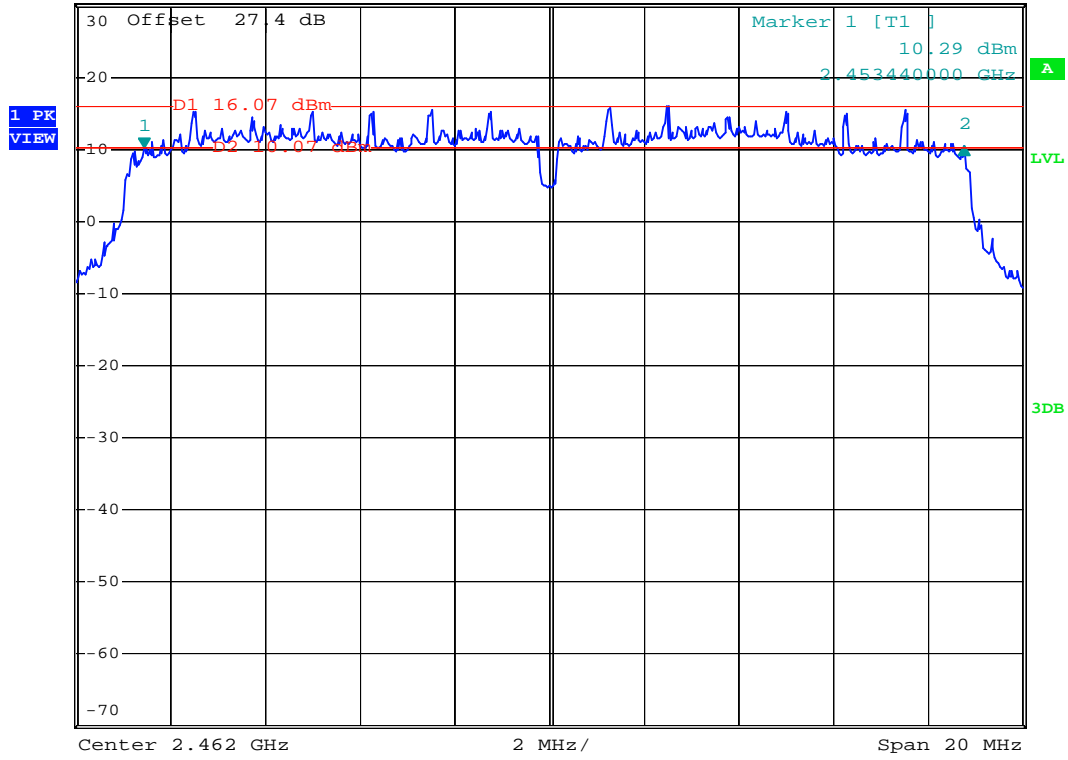

Date: 2.OCT.2007 17:06:04



Mode 13



Ref 30 dBm *Att 30 dB *RBW 100 kHz Delta 2 [T1]
*VBW 100 kHz 2.05 dB
*SWT 500 ms 35.840000000 MHz

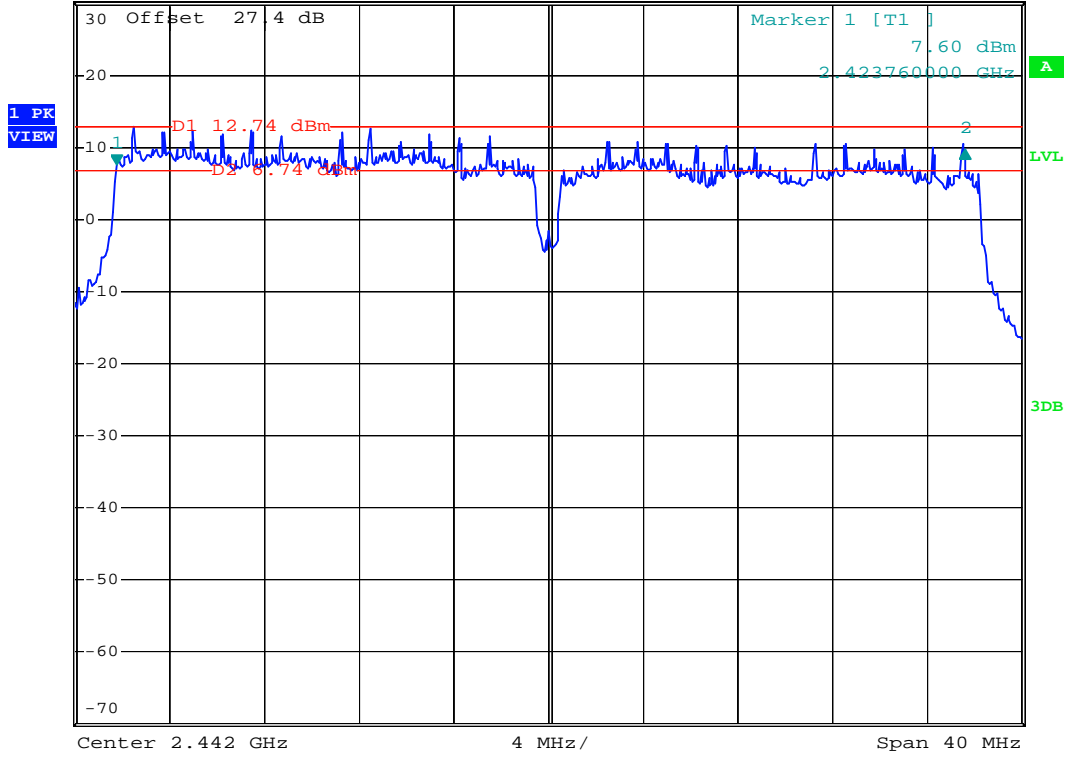

Date: 2.OCT.2007 18:26:16



Mode 14



Ref 30 dBm *Att 30 dB *RBW 100 kHz Delta 2 [T1]
*VBW 100 kHz -0.91 dB
*SWT 500 ms 36.400000000 MHz

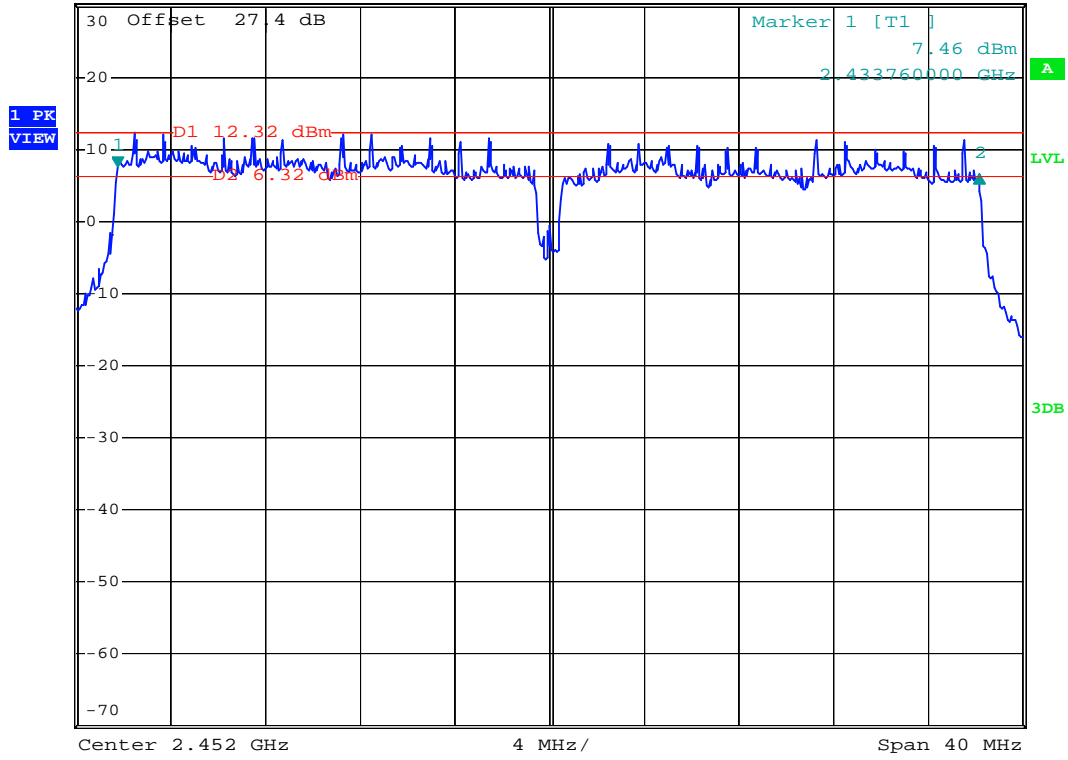

Date: 2.OCT.2007 18:27:30



Mode 15



Ref 20 dBm *Att 20 dB *RBW 100 kHz Delta 2 [T1]
*VBW 100 kHz -0.31 dB
*SWT 500 ms 17.160000000 MHz

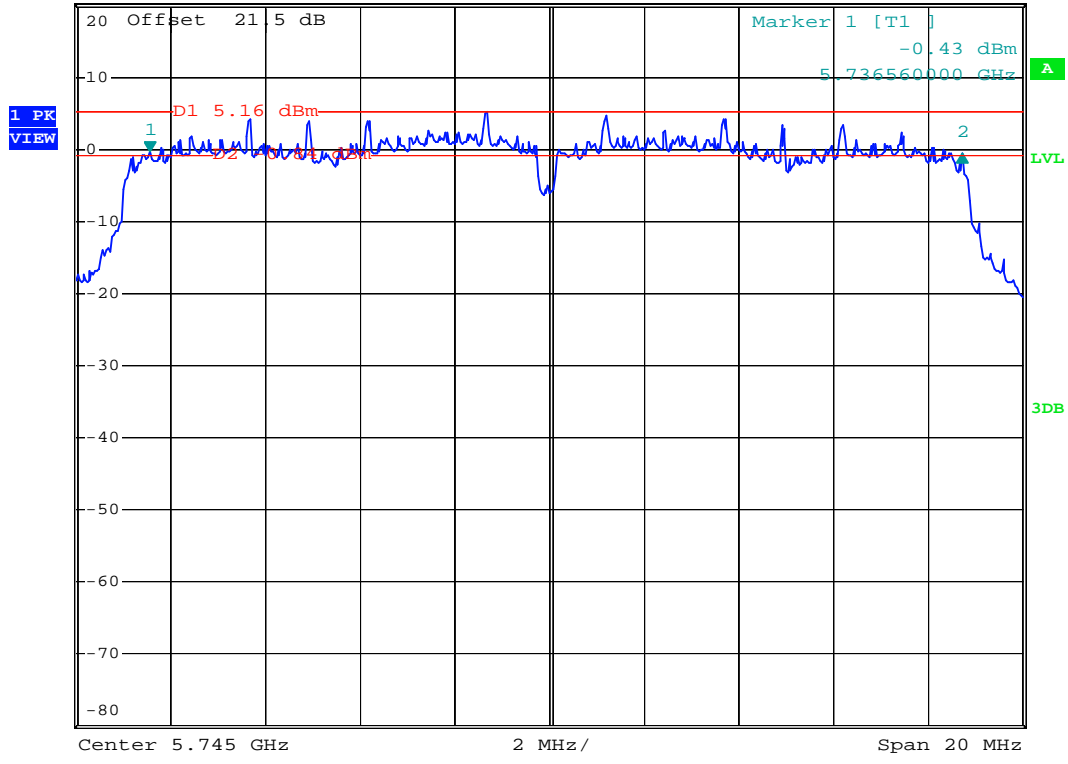

Date: 2.OCT.2007 15:26:27



Mode 16



Ref 20 dBm *Att 20 dB *RBW 100 kHz Delta 2 [T1]
*VBW 100 kHz -0.03 dB
*SWT 500 ms 17.080000000 MHz

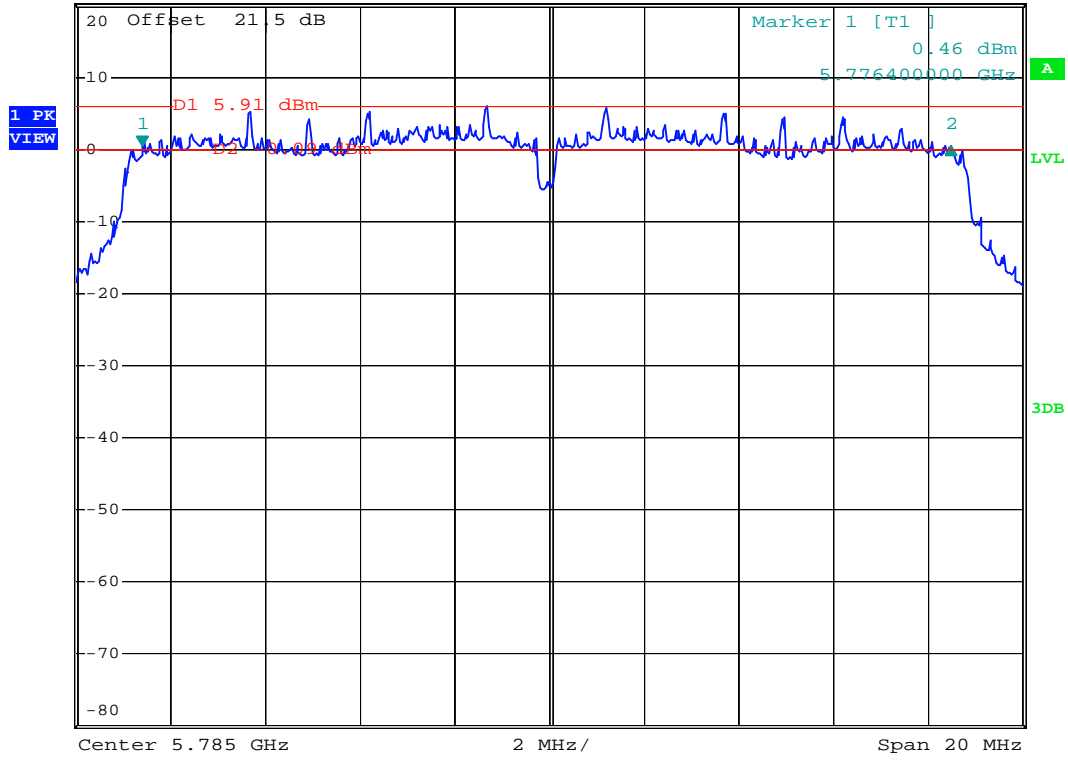

Date: 2.OCT.2007 15:34:53



Mode 17



Ref 20 dBm *Att 20 dB *RBW 100 kHz Delta 2 [T1]
*VBW 100 kHz -0.31 dB
*SWT 500 ms 17.320000000 MHz

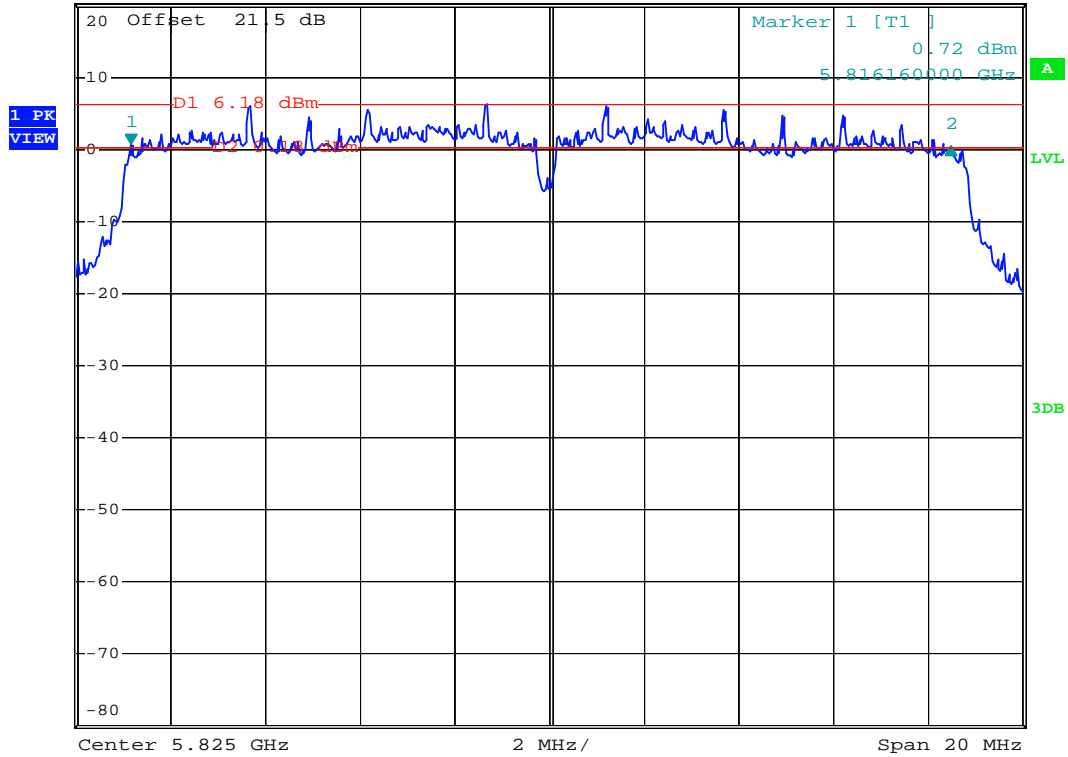

Date: 2.OCT.2007 15:37:00



Mode 18

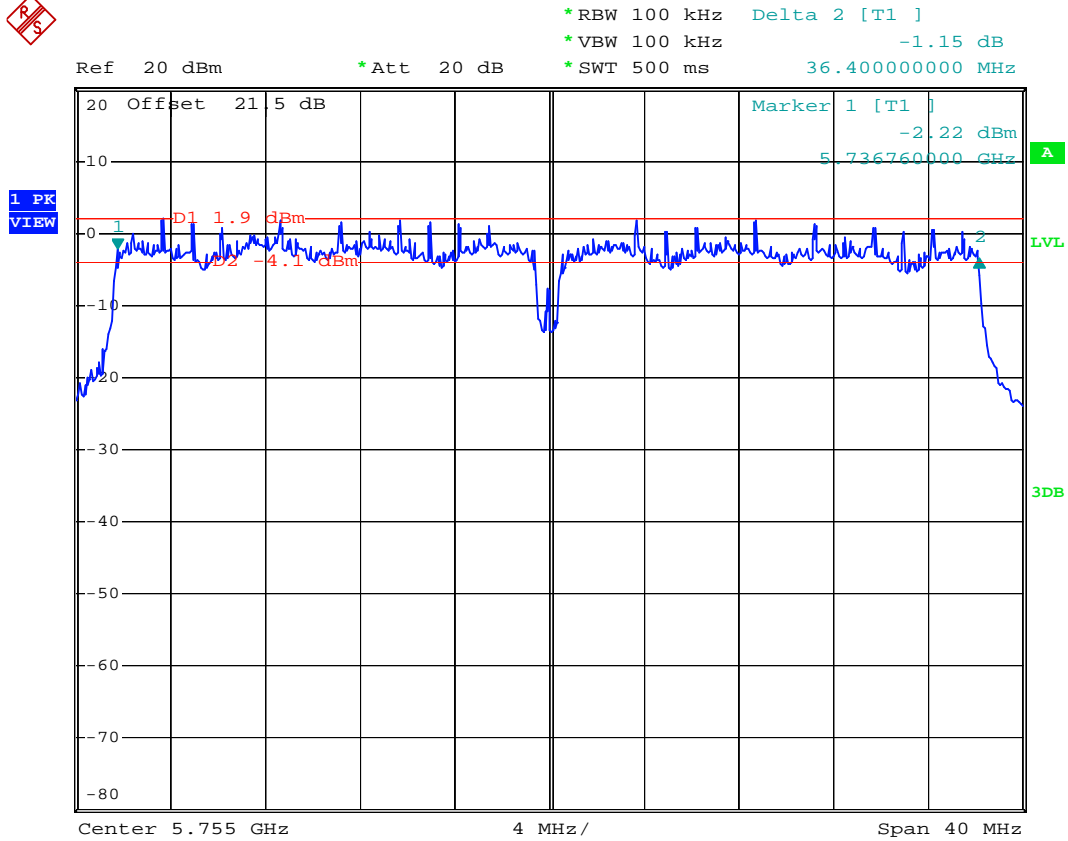

Date: 2.OCT.2007 15:57:31



Mode 19



Ref 20 dBm *Att 20 dB *RBW 100 kHz Delta 2 [T1]
*VBW 100 kHz -0.53 dB
*SWT 500 ms 36.400000000 MHz

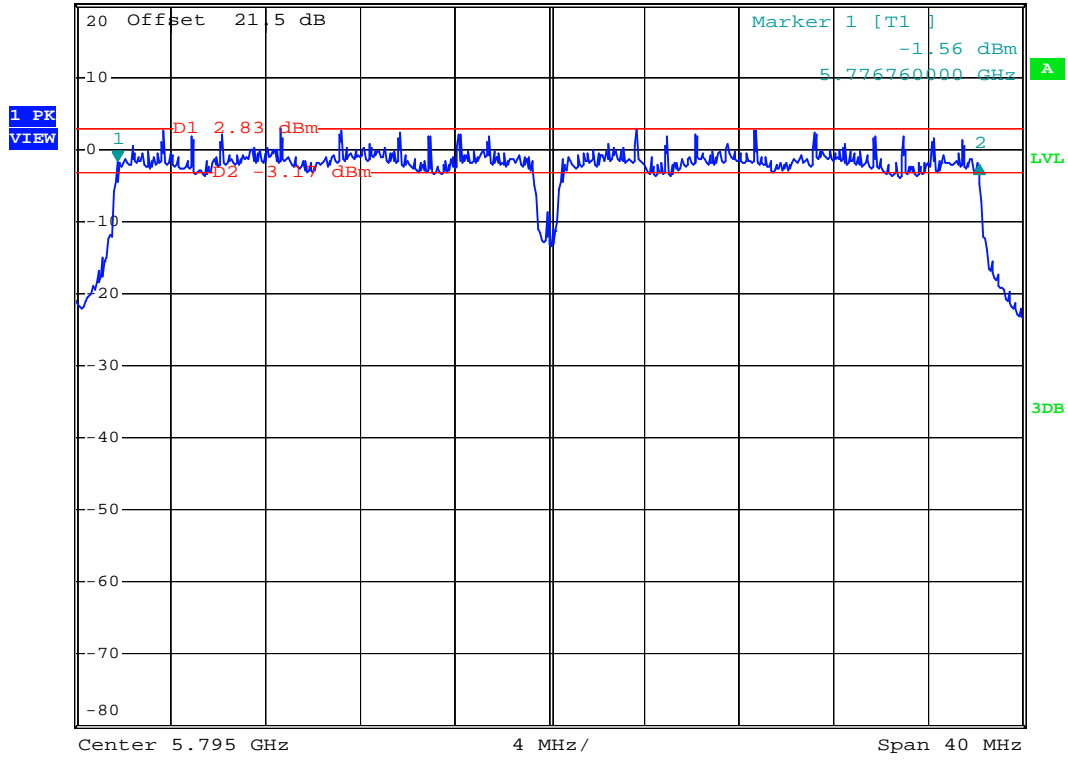

Date: 2.OCT.2007 16:01:44

5.3 Power Spectral Density Measurement

5.3.1 Measuring Instruments :

As described in chapter 6 of this test report.

5.3.2 Test Procedure :

1. The transmitter output was connected to spectrum analyzer directly.
2. The spectrum analyzer's resolution bandwidth was set at 3kHz RBW and 30kHz VBW as that of the fundamental frequency. Set the sweep time=span/3kHz.
3. The power spectral density was measured and recorded.
4. The sweep time is allowed to be longer than span/3kHz for a full response of the mixer in the spectrum analyzer.

5.3.3 Test Setup Layout :

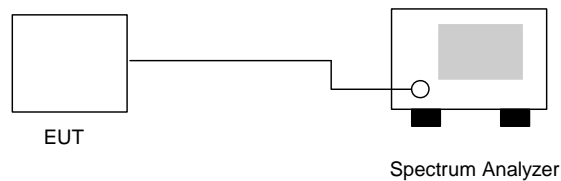



5.3.4 Test Result :

Application Type : 802.11b/g

Temperature : 25~26°C

Relative Humidity : 51~53%

Test Enginner : Sun**802.11b**

Channel	Frequency (MHz)	Power Spectral Density (dBm)	Limits (dBm)	Plot Ref. No.
01	2412	1.15	8	Mode 1
06	2437	1.24	8	Mode 2
11	2462	0.42	8	Mode 3

802.11g

Channel	Frequency (MHz)	Power Spectral Density (dBm)	Limits (dBm)	Plot Ref. No.
01	2412	-0.95	8	Mode 4
06	2437	-1.39	8	Mode 5
11	2462	-1.62	8	Mode 6

802.11a

Channel	Frequency (MHz)	Power Spectral Density (dBm)	Limits (dBm)	Plot Ref. No.
149	5745	-10.36	8	Mode 7
157	5785	-9.10	8	Mode 8
165	5825	-8.12	8	Mode 9

802.11n(g) BW 20M

Channel	Frequency (MHz)	Power Spectral Density (dBm)	Limits (dBm)	Plot Ref. No.
01	2412	3.82	8	Mode 10
06	2437	2.26	8	Mode 11
11	2462	2.71	8	Mode 12

**802.11n(g)_BW 40M**

Channel	Frequency (MHz)	Power Spectral Density (dBm)	Limits (dBm)	Plot Ref. No.
03	2422	-0.98	8	Mode 13
09	2452	-0.92	8	Mode 14

802.11n(a)_BW 20M

Channel	Frequency (MHz)	Power Spectral Density (dBm)	Limits (dBm)	Plot Ref. No.
149	5745	-8.67	8	Mode 15
157	5785	-8.15	8	Mode 16
165	5825	-7.51	8	Mode 17

802.11n(a)_BW 40M

Channel	Frequency (MHz)	Power Spectral Density (dBm)	Limits (dBm)	Plot Ref. No.
151	5755	-8.00	8	Mode 18
159	5795	-4.81	8	Mode 19



5.3.5 Power Spectral Density

Mode 1

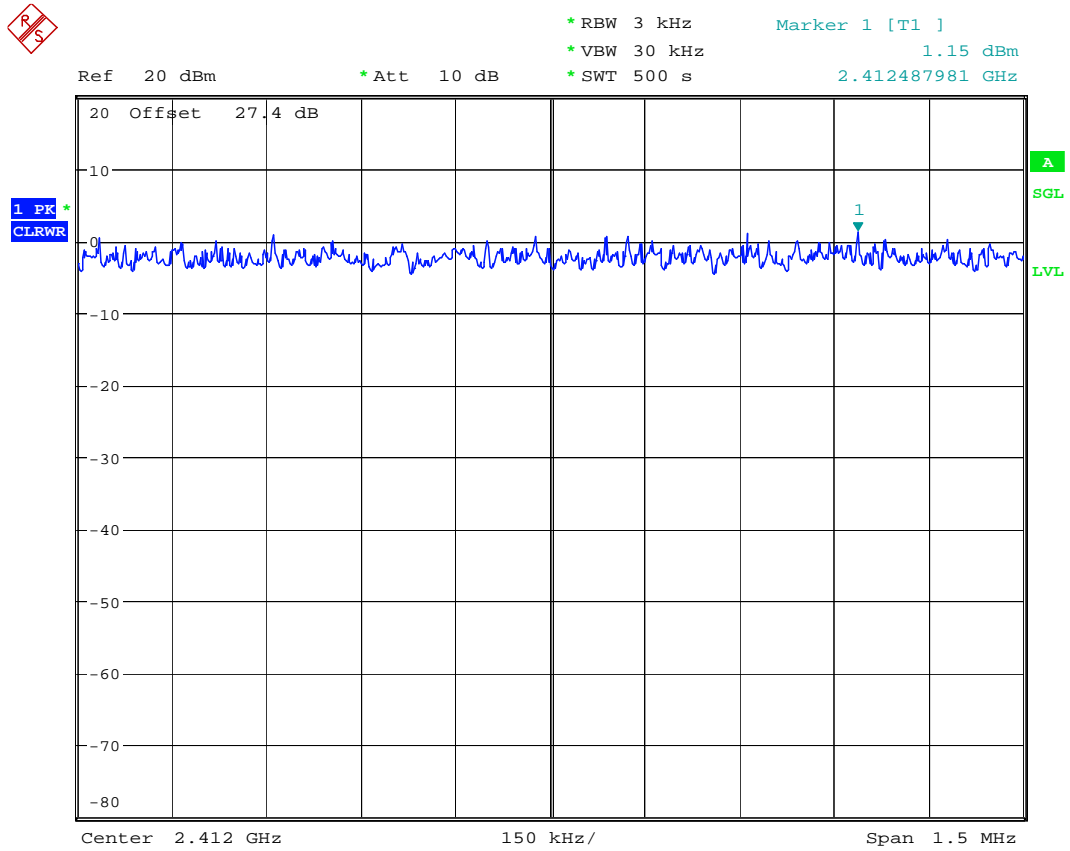

444

Date: 25.SEP.2007 22:34:39



Mode 2

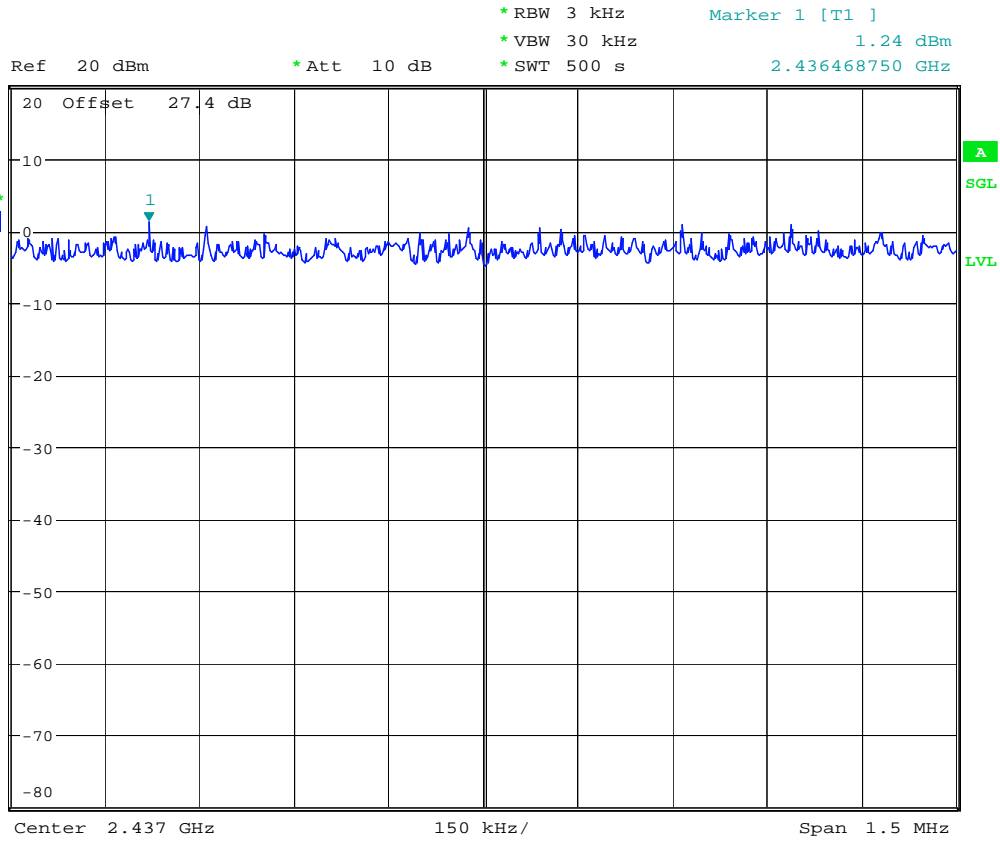

444

Date: 25.SEP.2007 22:24:45



Mode 3



*RBW 3 kHz Marker 1 [T1]
*VBW 30 kHz 0.42 dBm
*SWT 500 s 2.461560096 GHz

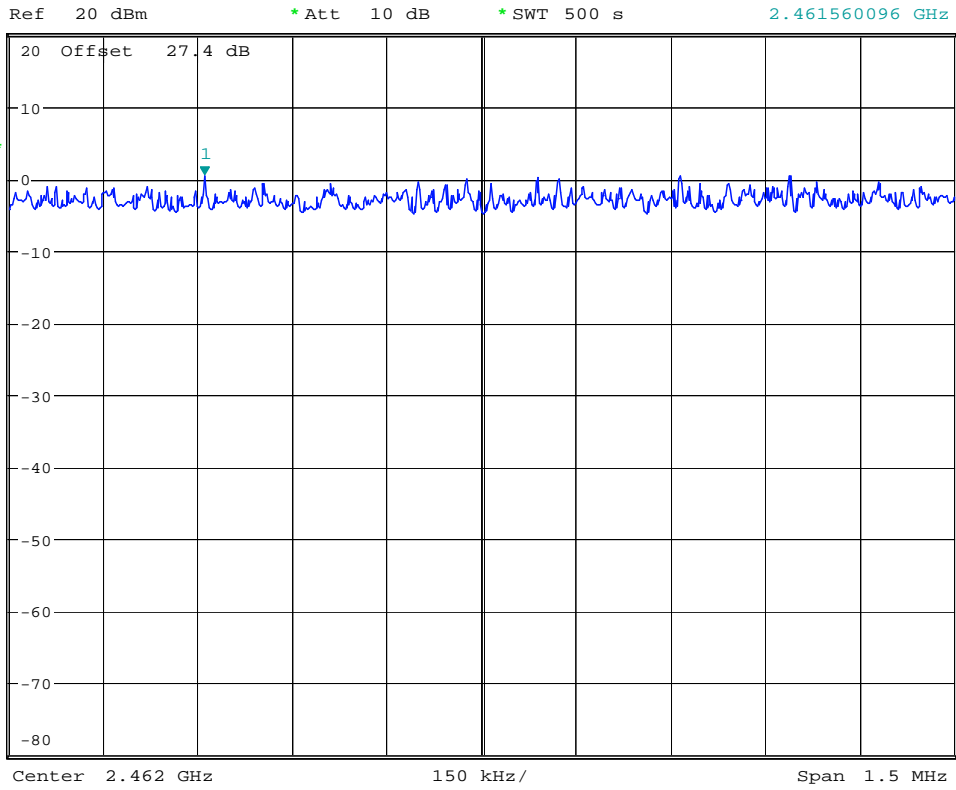

444

Date: 25.SEP.2007 22:15:40



Mode 4



*RBW 3 kHz Marker 1 [T1]
*VBW 30 kHz -0.95 dBm
*SWT 500 s 2.411334135 GHz

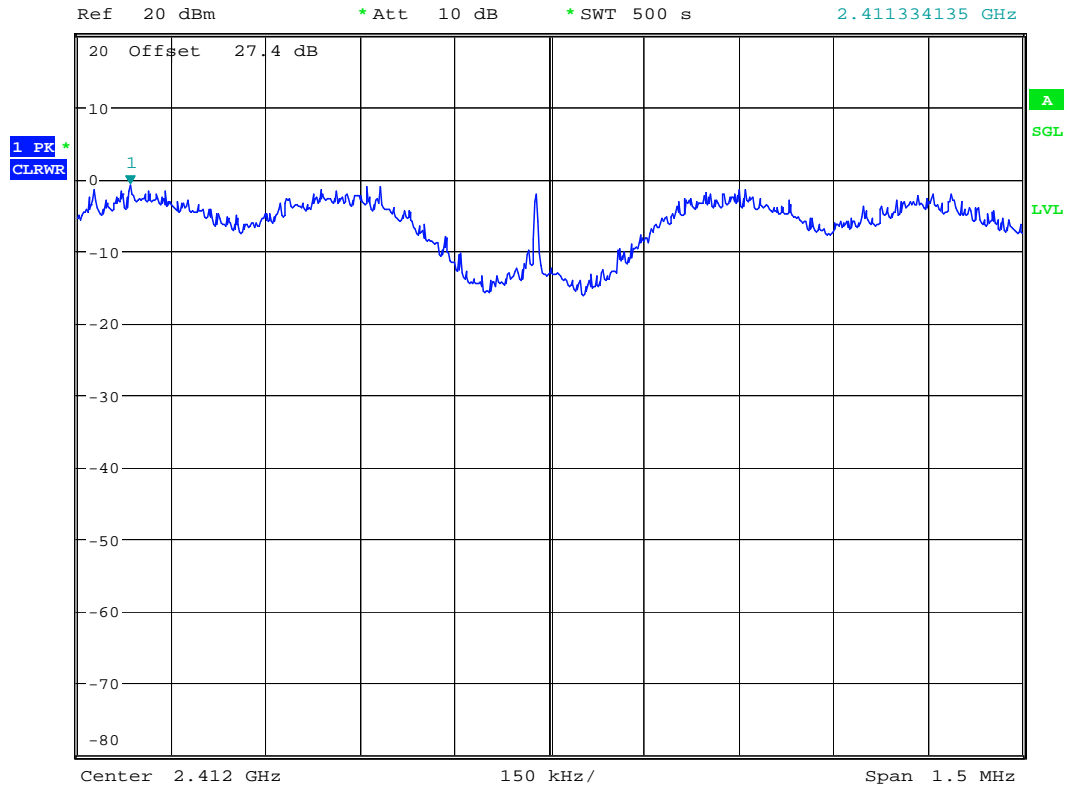

444

Date: 25.SEP.2007 21:05:25



Mode 5



*RBW 3 kHz Marker 1 [T1]
*VBW 30 kHz -1.39 dBm
*SWT 500 s 2.436730769 GHz

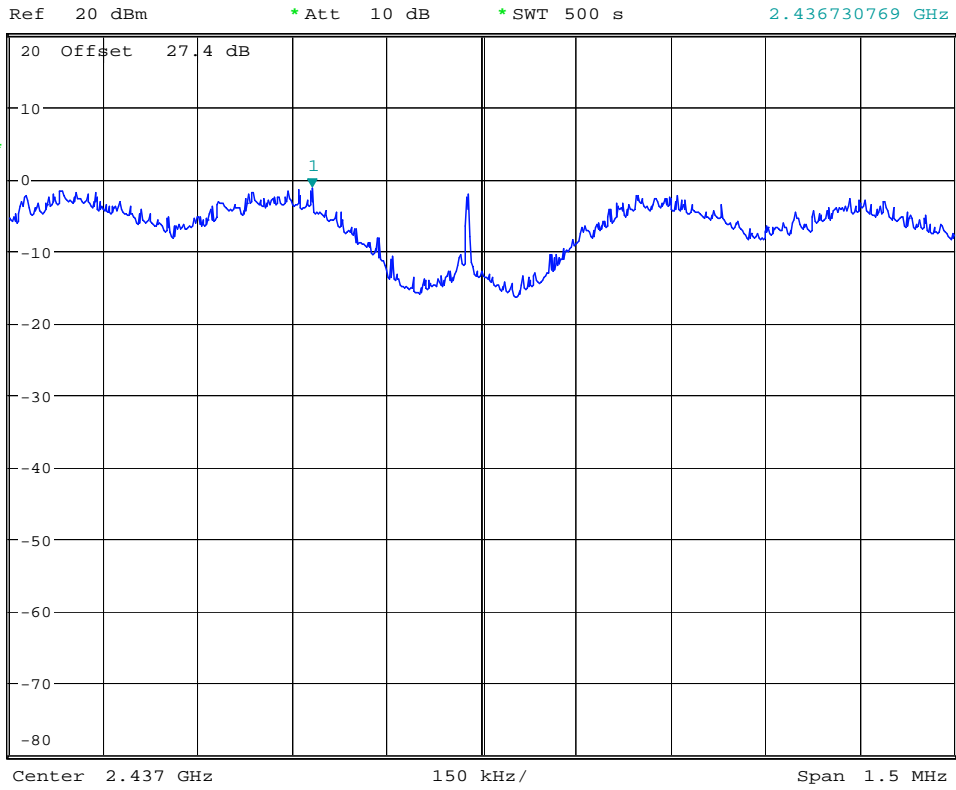

444

Date: 25.SEP.2007 21:15:45



Mode 6



*RBW 3 kHz Marker 1 [T1]
 *VBW 30 kHz -1.62 dBm
 *SWT 500 s 2.461334135 GHz

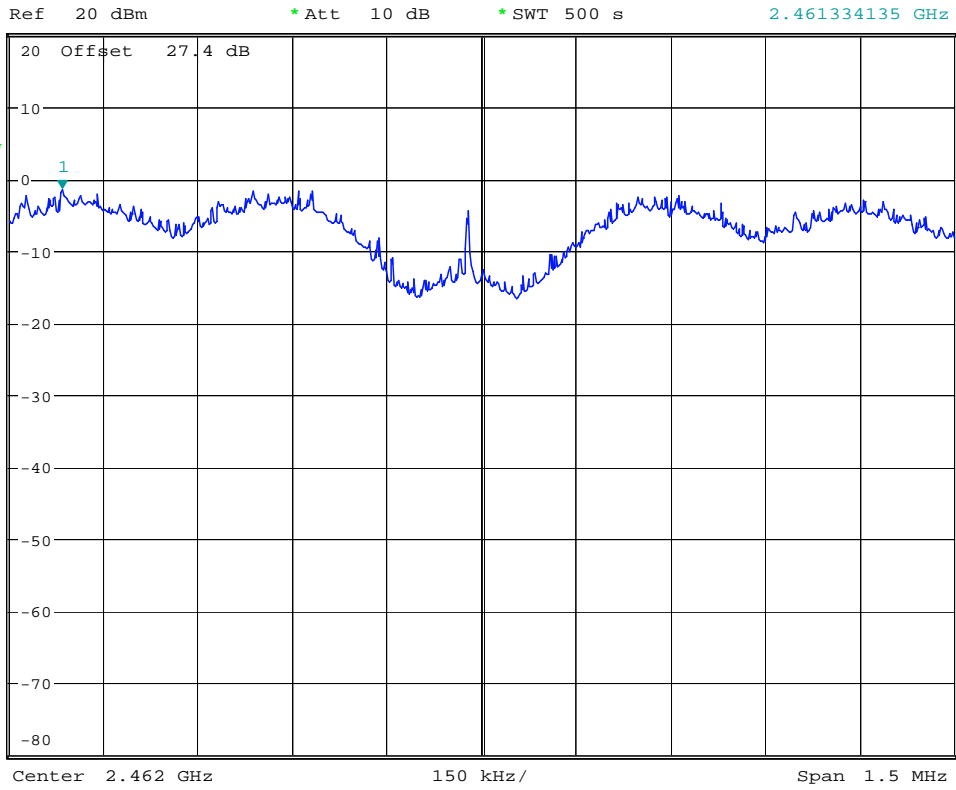

444

Date: 25.SEP.2007 21:29:06



Mode 7

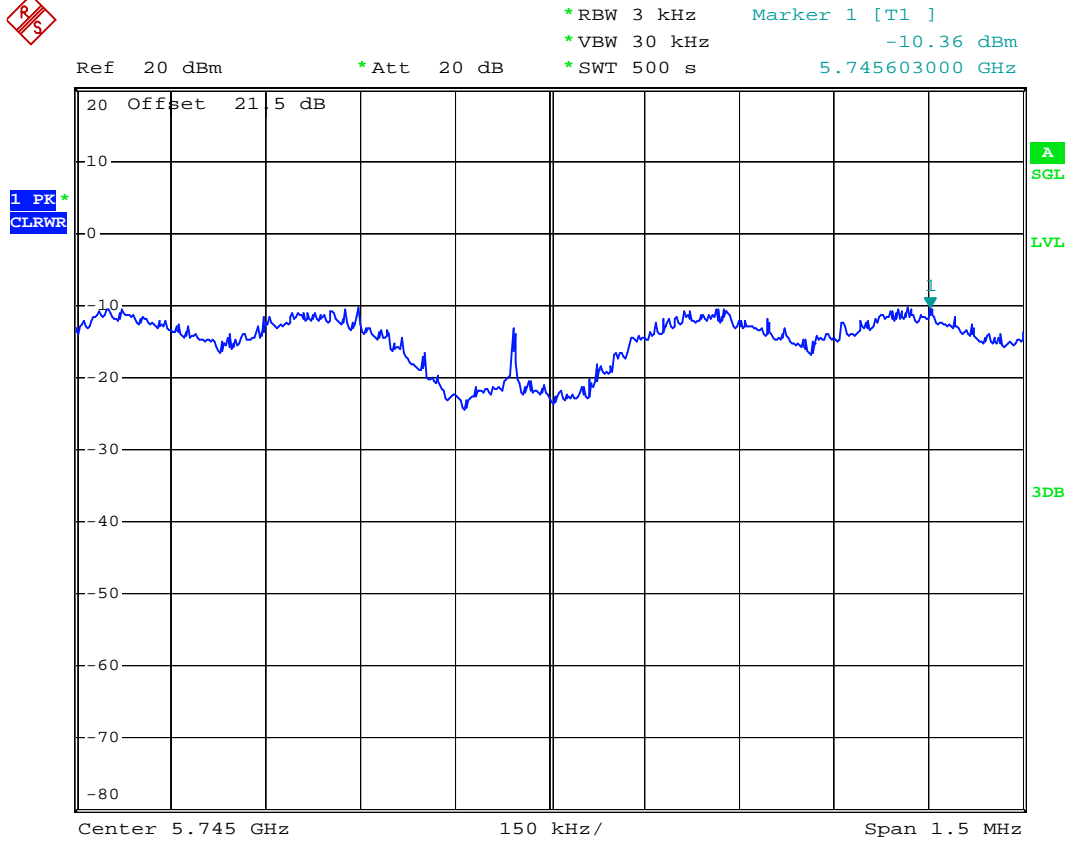

Date: 2.OCT.2007 12:34:13



Mode 8

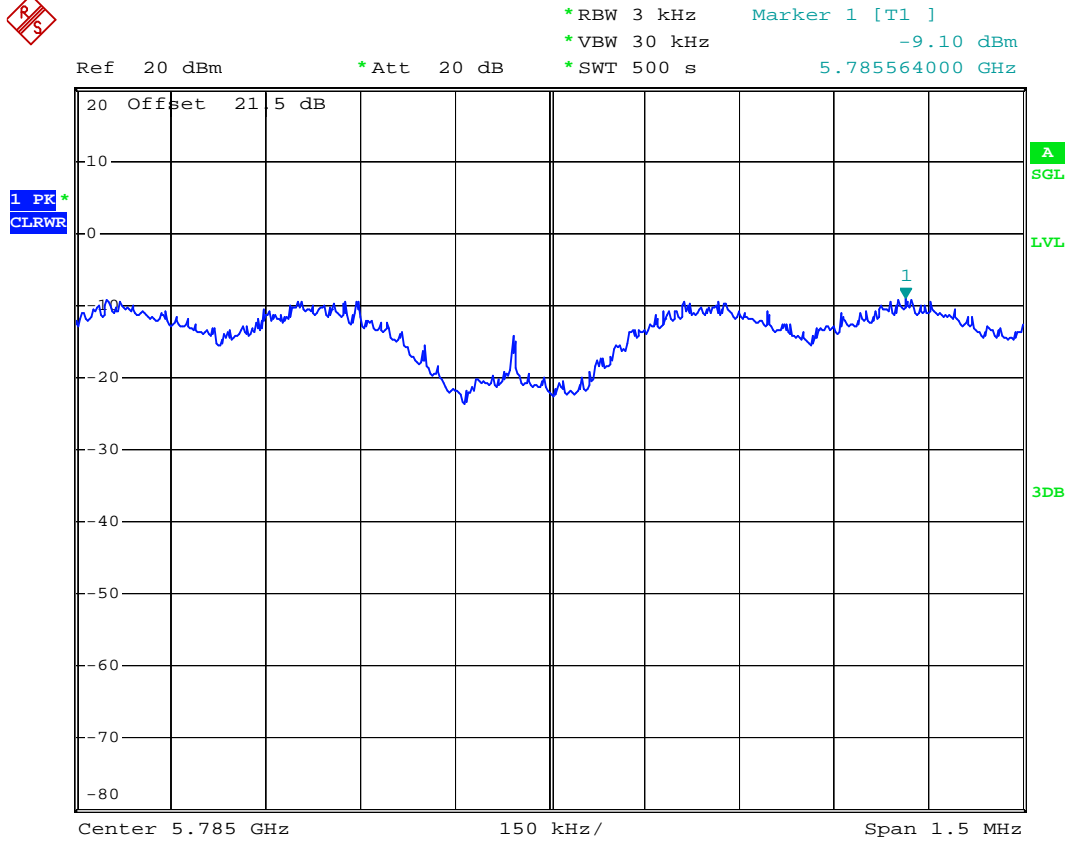

Date: 2.OCT.2007 14:17:54



Mode 9

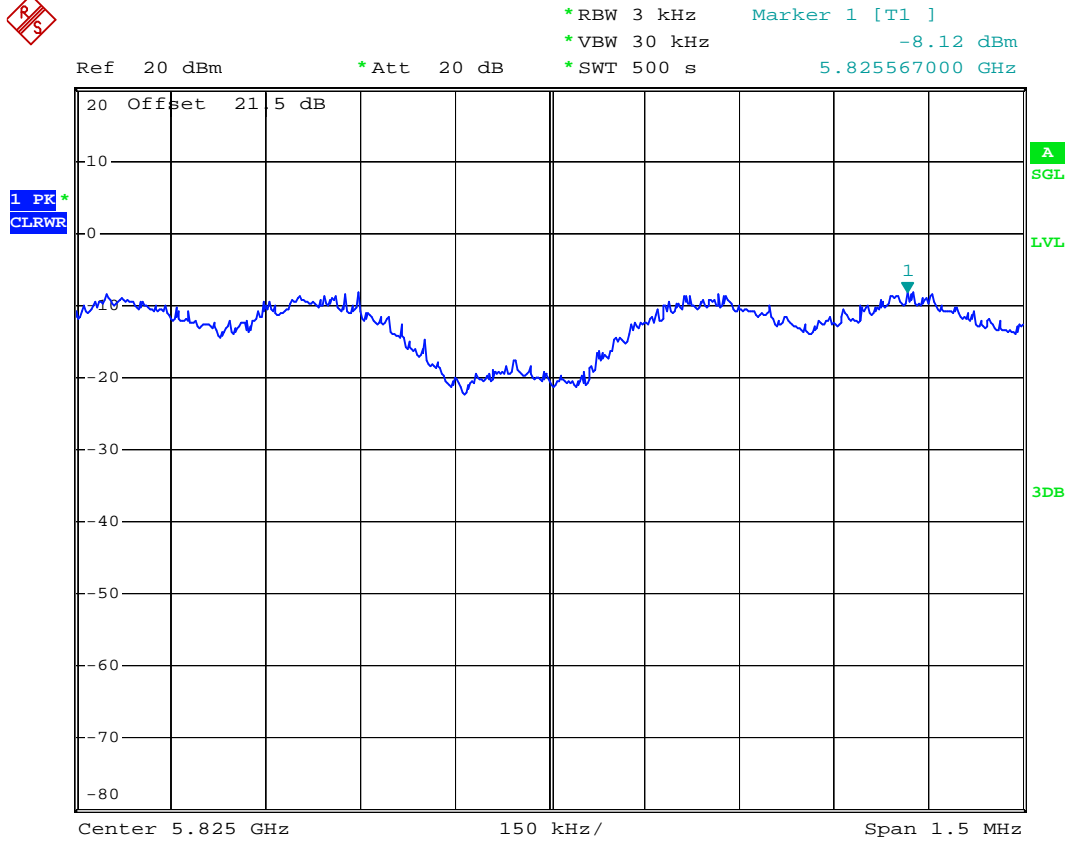

Date: 2.OCT.2007 14:27:03



Mode 10

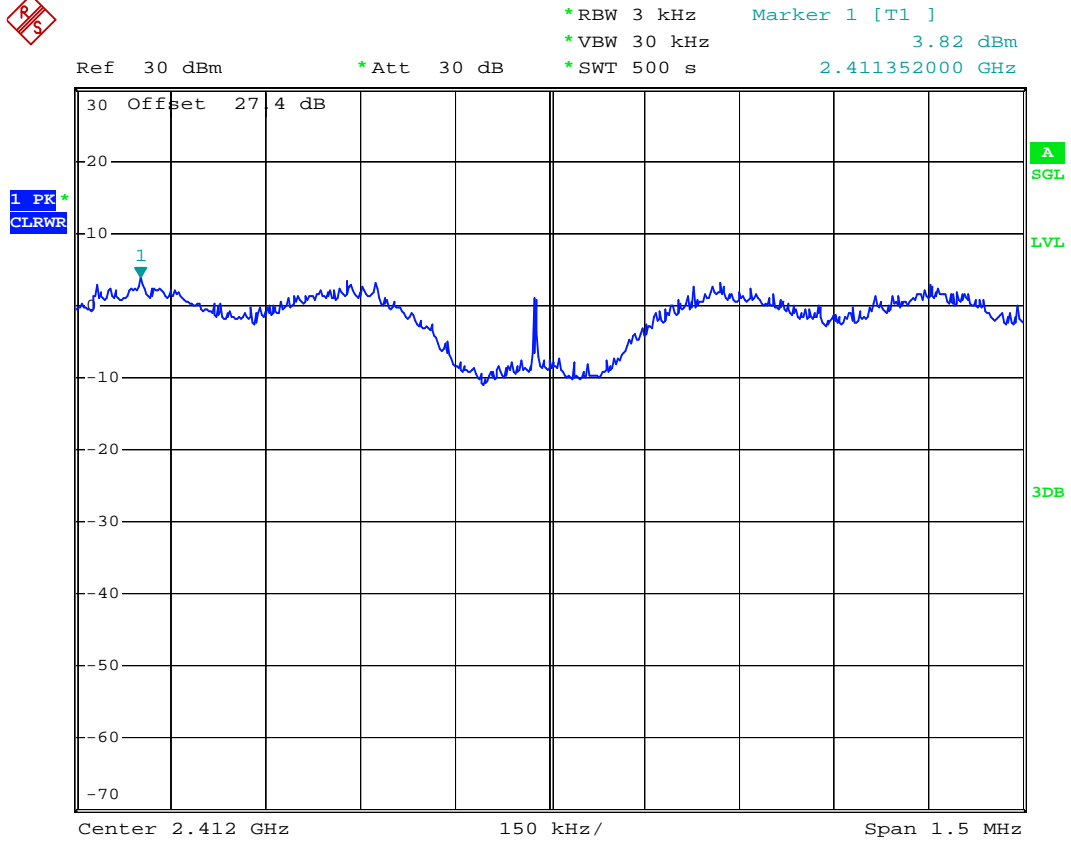

Date: 2.OCT.2007 17:28:19



Mode 11

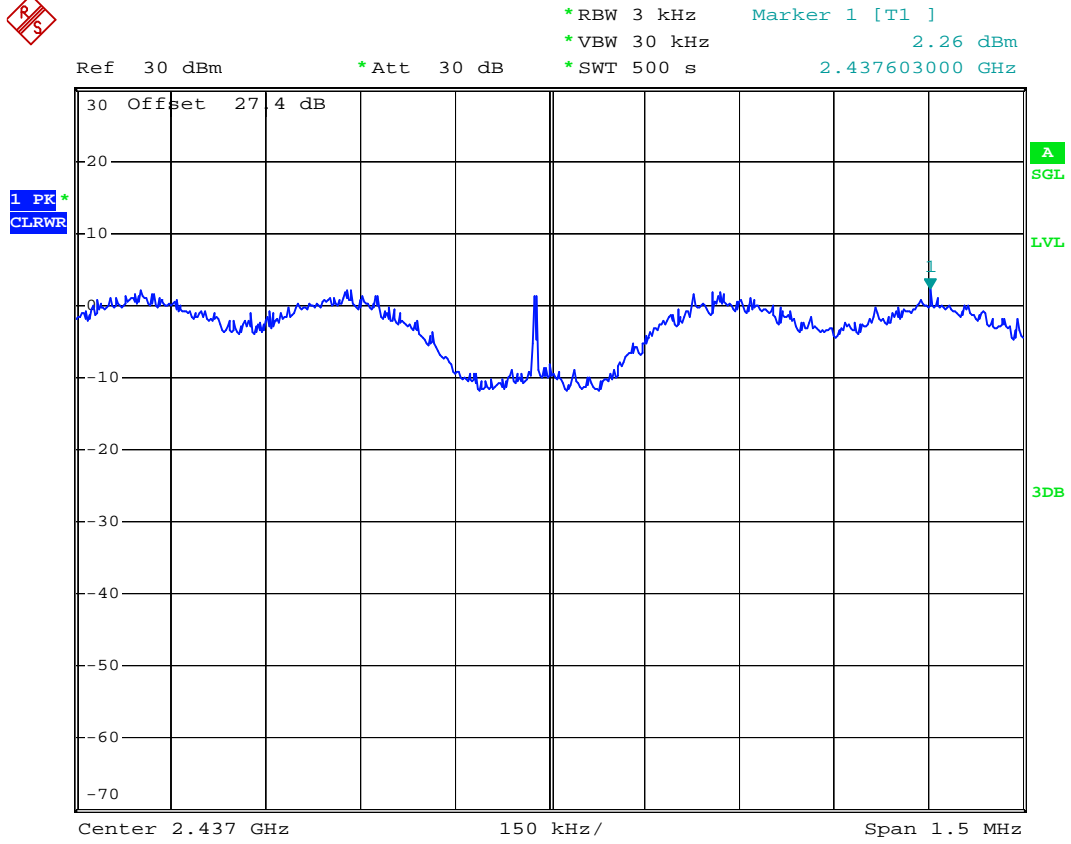

Date: 2.OCT.2007 17:41:00



Mode 12

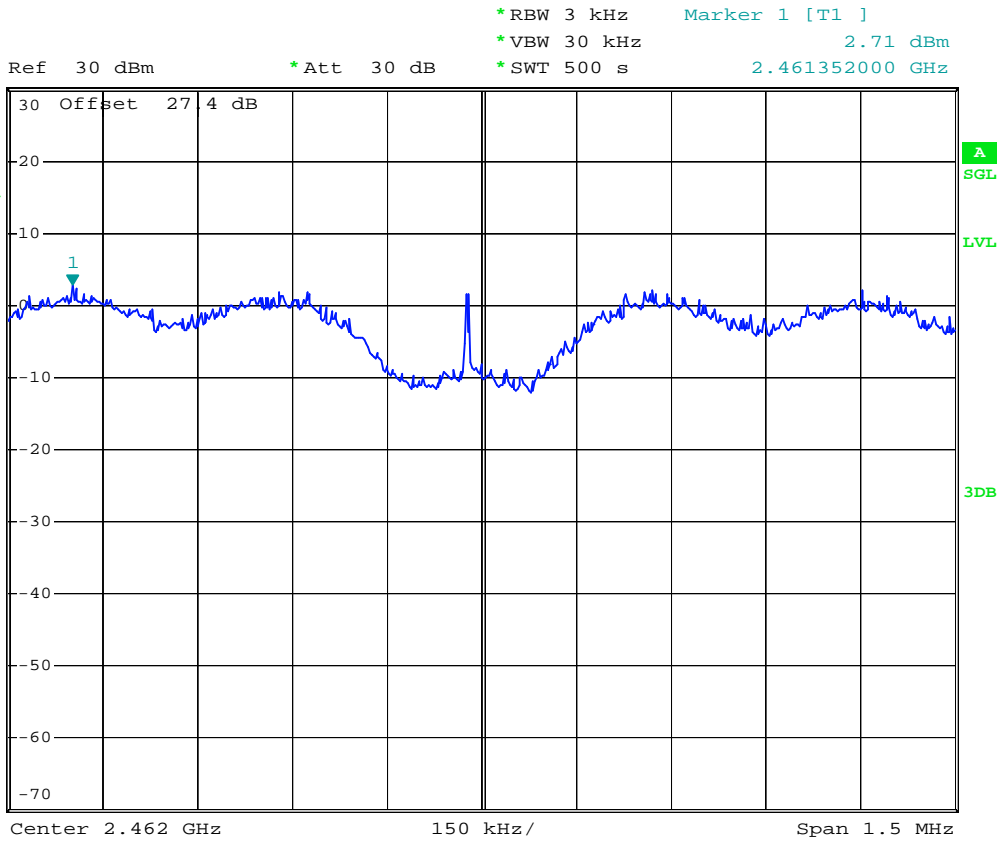

Date: 2.OCT.2007 17:50:38



Mode 13

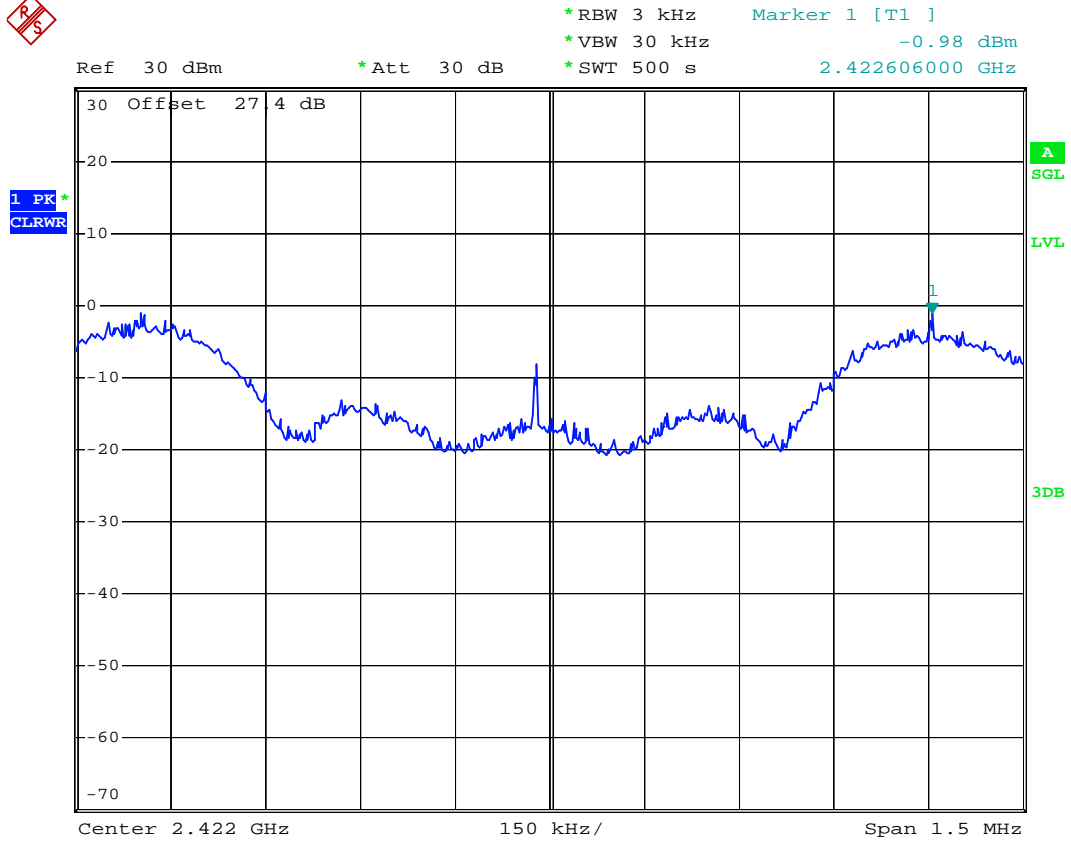

Date: 2.OCT.2007 18:49:36



Mode 14

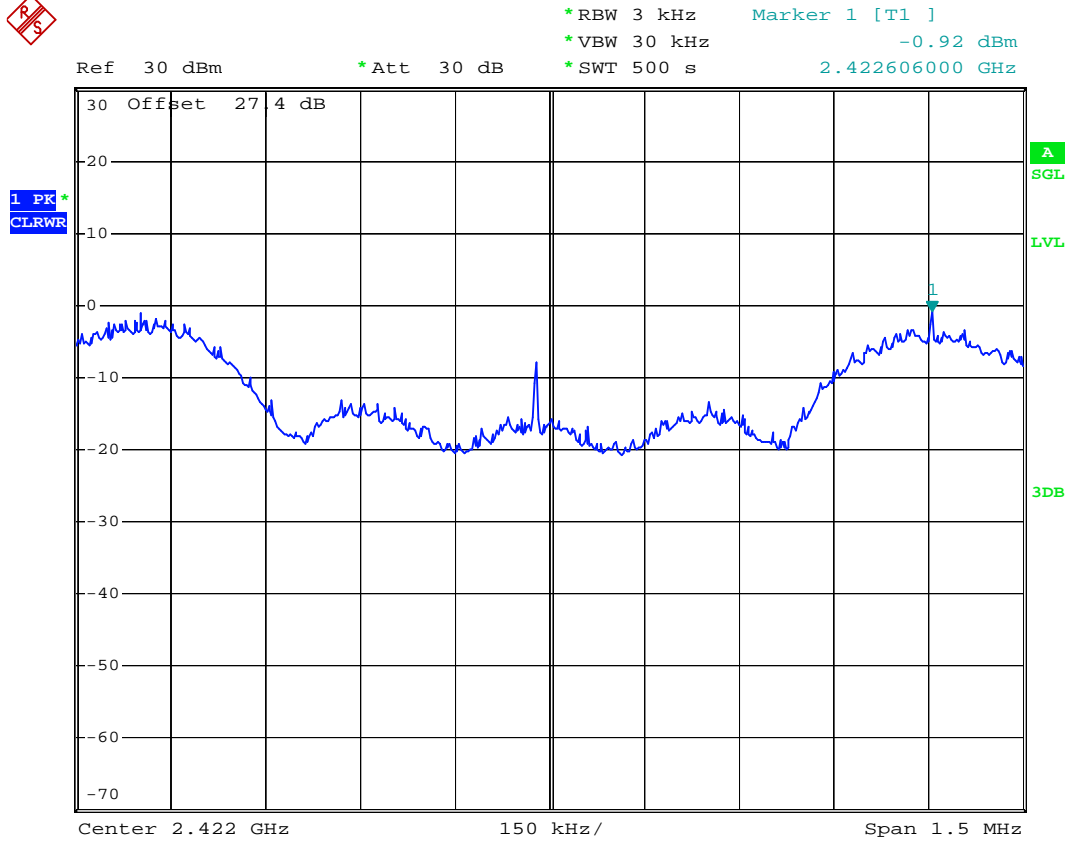

Date: 2.OCT.2007 18:58:47



Mode 15

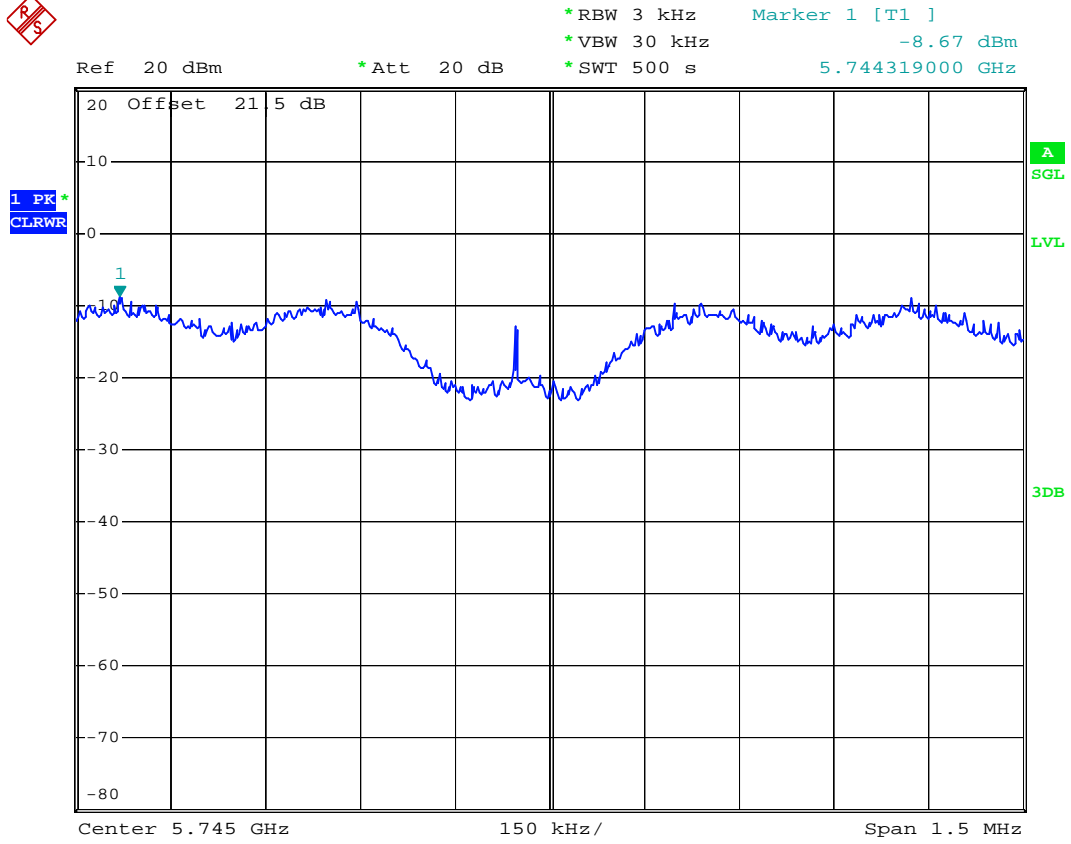

Date: 2.OCT.2007 14:48:23



Mode 16

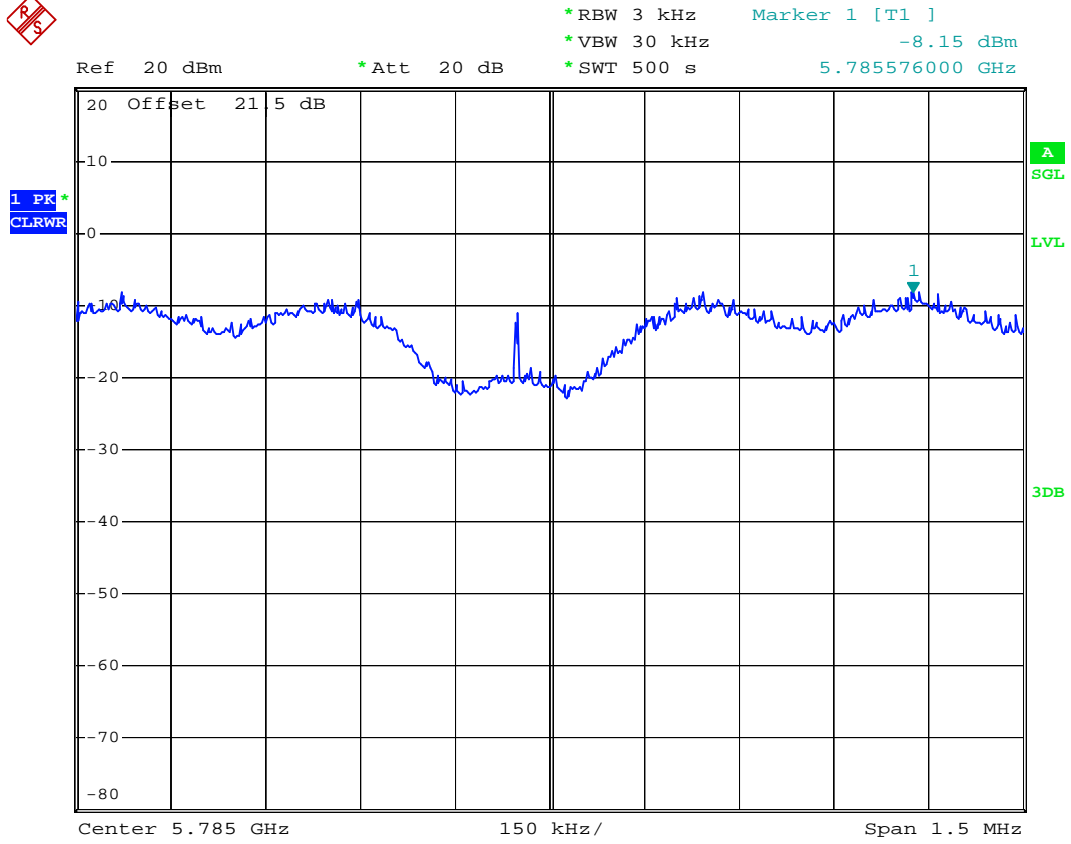

Date: 2.OCT.2007 14:57:28



Mode 17

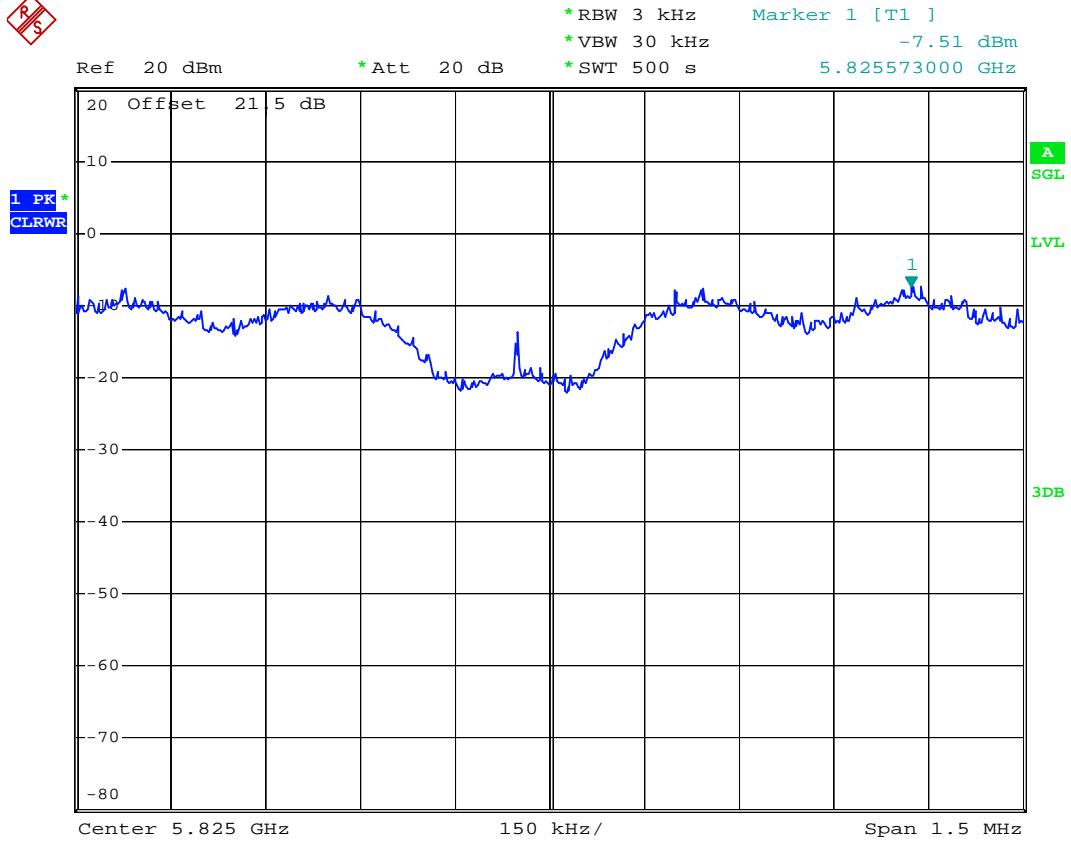

Date: 2.OCT.2007 15:15:33



Mode 18



Ref 20 dBm *Att 20 dB *RBW 3 kHz Marker 1 [T1] -8.00 dBm
*VBW 30 kHz *SWT 500 s 5.794952000 GHz

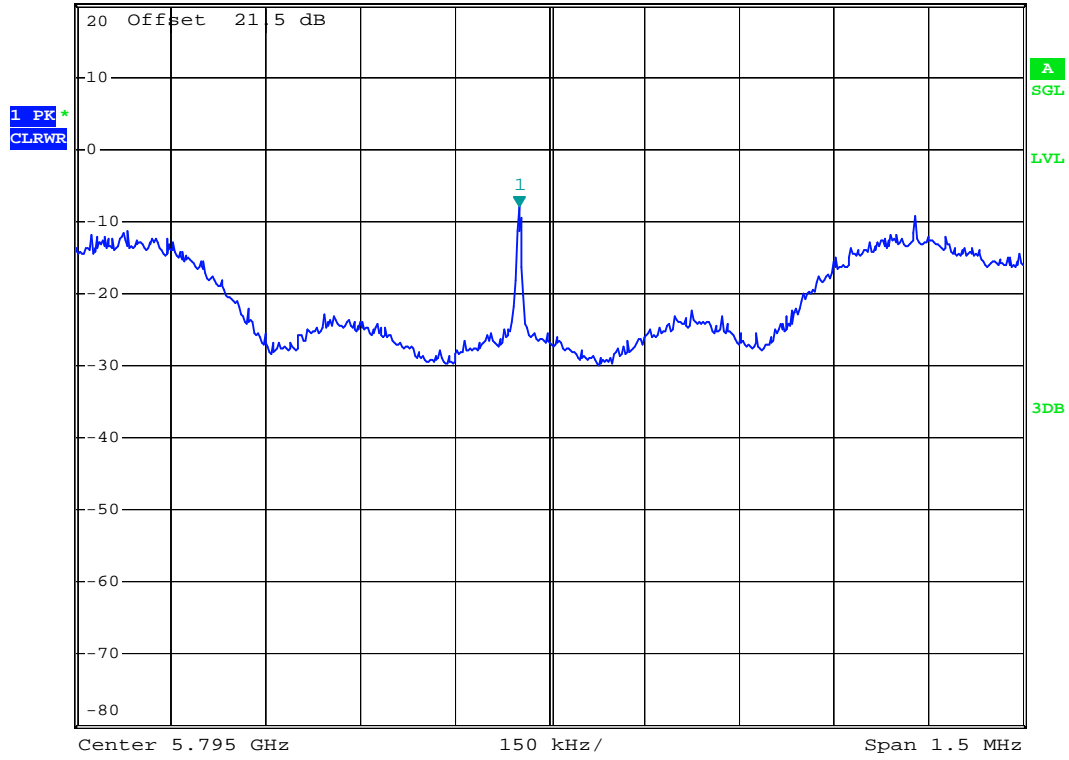

Date: 2.OCT.2007 16:34:19



Mode 19



Ref 20 dBm *Att 20 dB *RBW 3 kHz Marker 1 [T1] *VBW 30 kHz -4.81 dBm
*SWT 500 s 5.754955000 GHz

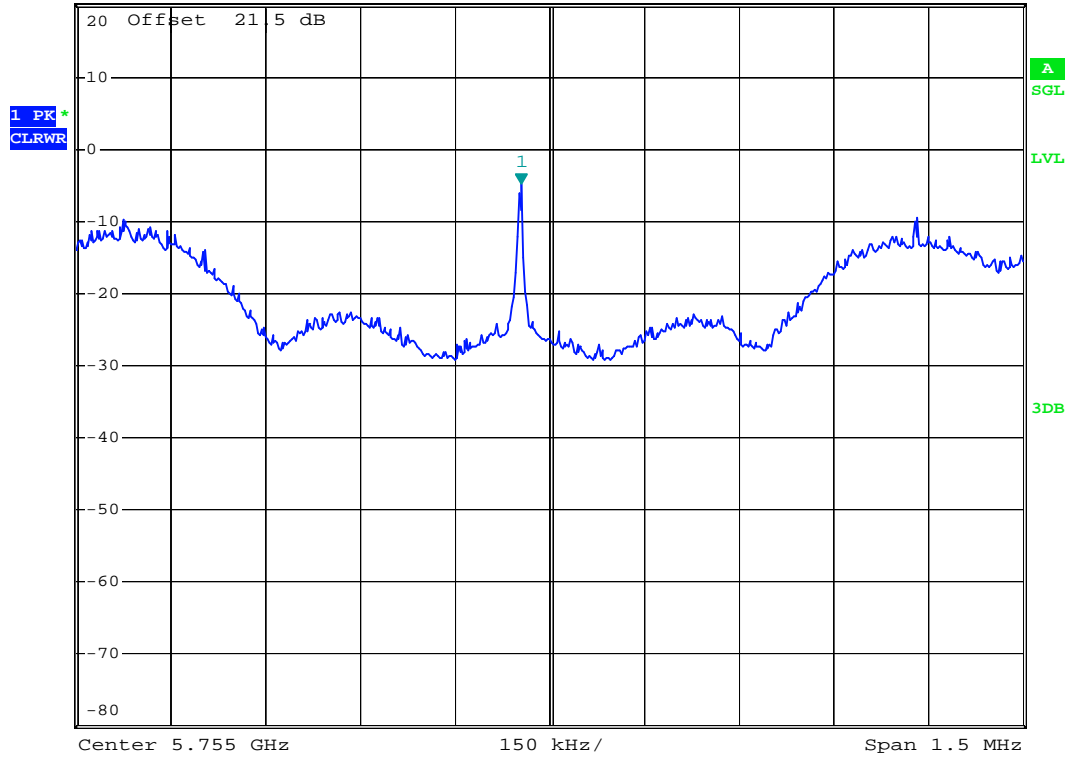

Date: 2.OCT.2007 16:43:23



5.4 Band Edges Measurement

5.4.1 Measuring Instruments :

As described in chapter 6 of this test report.

5.4.2 Test Procedure :

1. The transmitter output was connected to the spectrum analyzer via a low lose cable.
2. Set both RBW and VBW of spectrum analyzer to 100kHz with suitable frequency span including 100 kHz bandwidth from band edge.
3. The band edges was measured and recorded.

5.4.3 Test Result :

Application Type : WLAN 802.11b/g
Temperature : 25~26°C
Relative Humidity : 51~53%
Test Enginner : Sun

Test Result in WLAN lower band (802.11b/g)	: PASS
Test Result in WLAN higher band (802.11b/g)	: PASS
Test Result in WLAN lower band (802.11a Band III)	: PASS
Test Result in WLAN higher band (802.11a Band III)	: PASS
Test Result in WLAN lower band (802.11n<g>_BW 20M)	: PASS
Test Result in WLAN higher band (802.11n<g>_BW 20M)	: PASS
Test Result in WLAN lower band (802.11n<a>_BW 20M)	: PASS
Test Result in WLAN higher band (802.11n<a>_BW 20M)	: PASS
Test Result in WLAN lower band (802.11n<a>_BW 40M)	: PASS
Test Result in WLAN higher band (802.11n<a>_BW 40M)	: PASS



5.4.4 Note on Band Edge Emission :

➤WLAN 802.11b

CH01 (Horizontal)

Frequency (MHz)	Level (dBuV/m)	Over Limit (dB)	Limit Line (dBuV/m)	Read Level (dBuV)	Antenna Factor (dB)	Cable Loss (dB)	Preamp Factor (dB)	Ant Pos (cm)	Table Pos (deg)	Remark
2386.380	51.26	-22.75	74.00	53.21	28.07	3.74	33.78	100	0	Peak
2386.380	36.17	-17.83	54.00	38.13	28.07	3.74	33.78	100	289	Average

CH01 (Vertical)

Frequency (MHz)	Level (dBuV/m)	Over Limit (dB)	Limit Line (dBuV/m)	Read Level (dBuV)	Antenna Factor (dB)	Cable Loss (dB)	Preamp Factor (dB)	Ant Pos (cm)	Table Pos (deg)	Remark
2386.380	56.51	-17.49	74.00	58.47	28.07	3.74	33.78	100	0	Peak
2386.380	42.28	-11.72	54.00	44.24	28.07	3.74	33.78	100	112	Average

CH11 (Horizontal)

Frequency (MHz)	Level (dBuV/m)	Over Limit (dB)	Limit Line (dBuV/m)	Read Level (dBuV)	Antenna Factor (dB)	Cable Loss (dB)	Preamp Factor (dB)	Ant Pos (cm)	Table Pos (deg)	Remark
2488.220	45.76	-20.24	74.00	47.42	28.30	3.84	33.80	100	0	Peak
2488.220	31.71	-22.29	54.00	33.37	28.30	3.84	33.80	100	289	Average

CH11 (Vertical)

Frequency (MHz)	Level (dBuV/m)	Over Limit (dB)	Limit Line (dBuV/m)	Read Level (dBuV)	Antenna Factor (dB)	Cable Loss (dB)	Preamp Factor (dB)	Ant Pos (cm)	Table Pos (deg)	Remark
2485.180	53.27	-20.73	74.00	54.97	28.26	3.84	33.80	100	0	Peak
2485.180	41.18	-12.82	54.00	42.88	28.26	3.84	33.80	100	113	Average



➤ WLAN 802.11g

CH01 (Horizontal)

Frequency (MHz)	Level (dBuV/m)	Over Limit (dB)	Limit Line (dBuV/m)	Read Level (dBuV)	Antenna Factor (dB)	Cable Loss (dB)	Preamp Factor (dB)	Ant Pos (cm)	Table Pos (deg)	Remark
2389.610	44.28	-9.72	54.00	46.24	28.07	3.74	33.78	100	242	Average
2389.610	63.90	-10.10	74.00	65.86	28.07	3.74	33.78	100	0	Peak

CH01 (Vertical)

Frequency (MHz)	Level (dBuV/m)	Over Limit (dB)	Limit Line (dBuV/m)	Read Level (dBuV)	Antenna Factor (dB)	Cable Loss (dB)	Preamp Factor (dB)	Ant Pos (cm)	Table Pos (deg)	Remark
2387.330	68.54	-5.46	74.00	70.50	23.07	3.74	33.78	100	0	Peak
2387.330	42.86	-11.14	54.00	44.82	28.07	3.74	33.78	100	112	Average

CH11 (Horizontal)

Frequency (MHz)	Level (dBuV/m)	Over Limit (dB)	Limit Line (dBuV/m)	Read Level (dBuV)	Antenna Factor (dB)	Cable Loss (dB)	Preamp Factor (dB)	Ant Pos (cm)	Table Pos (deg)	Remark
2483.850	63.46	-10.54	74.00	65.16	28.26	3.84	33.80	100	0	Peak
2483.850	42.17	-11.83	54.00	43.87	28.26	3.84	33.80	100	115	Average

CH11 (Vertical)

Frequency (MHz)	Level (dBuV/m)	Over Limit (dB)	Limit Line (dBuV/m)	Read Level (dBuV)	Antenna Factor (dB)	Cable Loss (dB)	Preamp Factor (dB)	Ant Pos (cm)	Table Pos (deg)	Remark
2483.850	70.60	-3.40	74.00	72.30	28.26	3.84	33.80	100	0	Peak
2483.850	50.15	-3.85	54.00	51.85	28.26	3.84	33.80	100	113	Average

➤ WLAN 802.11n(g)_BW 20M

CH01 (Horizontal)

Frequency (MHz)	Level (dBuV/m)	Over Limit (dB)	Limit Line (dBuV/m)	Read Level (dBuV)	Antenna Factor (dB)	Cable Loss (dB)	Preamp Factor (dB)	Ant Pos (cm)	Table Pos (deg)	Remark
2390.000	57.50	-16.50	74.00	59.47	28.07	3.74	33.78	100	0	Peak
2390.000	37.21	-16.79	54.00	39.18	28.07	3.74	33.78	100	256	Average

**CH01 (Vertical)**

Frequency (MHz)	Level (dBuV/m)	Over Limit (dB)	Limit Line (dBuV/m)	Read Level (dBuV)	Antenna Factor (dB)	Cable Loss (dB)	Preamp Factor (dB)	Ant Pos (cm)	Table Pos (deg)	Remark
2390.000	59.70	-14.30	74.00	61.67	28.07	3.74	33.78	100	0	Peak
2390.000	42.79	-11.21	54.00	44.76	28.07	3.74	33.78	100	359	Average

CH11 (Horizontal)

Frequency (MHz)	Level (dBuV/m)	Over Limit (dB)	Limit Line (dBuV/m)	Read Level (dBuV)	Antenna Factor (dB)	Cable Loss (dB)	Preamp Factor (dB)	Ant Pos (cm)	Table Pos (deg)	Remark
2483.500	56.60	-17.40	74.00	58.30	28.26	3.84	33.80	100	0	Peak
2483.500	36.32	-17.68	54.00	38.02	28.26	3.84	33.80	100	262	Average

CH11 (Vertical)

Frequency (MHz)	Level (dBuV/m)	Over Limit (dB)	Limit Line (dBuV/m)	Read Level (dBuV)	Antenna Factor (dB)	Cable Loss (dB)	Preamp Factor (dB)	Ant Pos (cm)	Table Pos (deg)	Remark
2484.420	61.70	-12.30	74.00	63.40	28.26	3.84	33.80	100	0	Peak
2484.420	41.70	-12.30	54.00	43.40	28.26	3.84	33.80	100	22	Average

➤ WLAN 802.11n(g)_BW 40M**CH03 (Horizontal)**

Frequency (MHz)	Level (dBuV/m)	Over Limit (dB)	Limit Line (dBuV/m)	Read Level (dBuV)	Antenna Factor (dB)	Cable Loss (dB)	Preamp Factor (dB)	Ant Pos (cm)	Table Pos (deg)	Remark
2390.000	42.67	-11.33	54.00	44.46	28.07	3.74	33.78	100	261	Average
2390.000	62.23	-11.77	74.00	64.20	28.07	3.74	33.78	100	0	Peak

CH03 (Vertical)

Frequency (MHz)	Level (dBuV/m)	Over Limit (dB)	Limit Line (dBuV/m)	Read Level (dBuV)	Antenna Factor (dB)	Cable Loss (dB)	Preamp Factor (dB)	Ant Pos (cm)	Table Pos (deg)	Remark
2390.000	46.84	-7.16	54.00	48.81	28.07	3.74	33.78	100	357	Average
2390.000	68.15	-5.85	74.00	70.12	28.07	3.74	33.78	100	0	Peak

**CH9 (Horizontal)**

Frequency (MHz)	Level (dBuV/m)	Over Limit (dB)	Limit Line (dBuV/m)	Read Level (dBuV)	Antenna Factor (dB)	Cable Loss (dB)	Preamp Factor (dB)	Ant Pos (cm)	Table Pos (deg)	Remark
2483.500	59.59	-14.41	74.00	61.29	28.26	3.84	33.80	100	0	Peak
2483.500	39.33	-14.67	54.00	41.03	28.26	3.84	33.80	100	255	Average

CH9 (Vertical)

Frequency (MHz)	Level (dBuV/m)	Over Limit (dB)	Limit Line (dBuV/m)	Read Level (dBuV)	Antenna Factor (dB)	Cable Loss (dB)	Preamp Factor (dB)	Ant Pos (cm)	Table Pos (deg)	Remark
2483.500	65.77	-8.23	74.00	67.47	28.26	3.84	33.80	100	0	Peak
2483.500	46.17	-7.83	54.00	47.87	28.26	3.84	33.80	100	3	Average

➤ **WLAN 802.11n(g)_BW 40M (Module 2)****CH03 (Horizontal)**

Frequency (MHz)	Level (dBuV/m)	Over Limit (dB)	Limit Line (dBuV/m)	Read Level (dBuV)	Antenna Factor (dB)	Cable Loss (dB)	Preamp Factor (dB)	Ant Pos (cm)	Table Pos (deg)	Remark
2388.090	41.32	-12.68	54.00	43.28	28.07	3.74	33.78	100	169	Average
2388.090	63.31	-10.69	74.00	65.27	28.07	3.74	33.78	100	0	Peak

CH03 (Vertical)

Frequency (MHz)	Level (dBuV/m)	Over Limit (dB)	Limit Line (dBuV/m)	Read Level (dBuV)	Antenna Factor (dB)	Cable Loss (dB)	Preamp Factor (dB)	Ant Pos (cm)	Table Pos (deg)	Remark
2388.850	68.96	-5.04	74.00	70.92	28.07	3.74	33.78	100	0	Peak
2388.850	47.11	-6.89	54.00	49.07	28.07	3.74	33.78	100	356	Average



5.4.5 20dB Band Edge

WLAN 802.11b

CH01

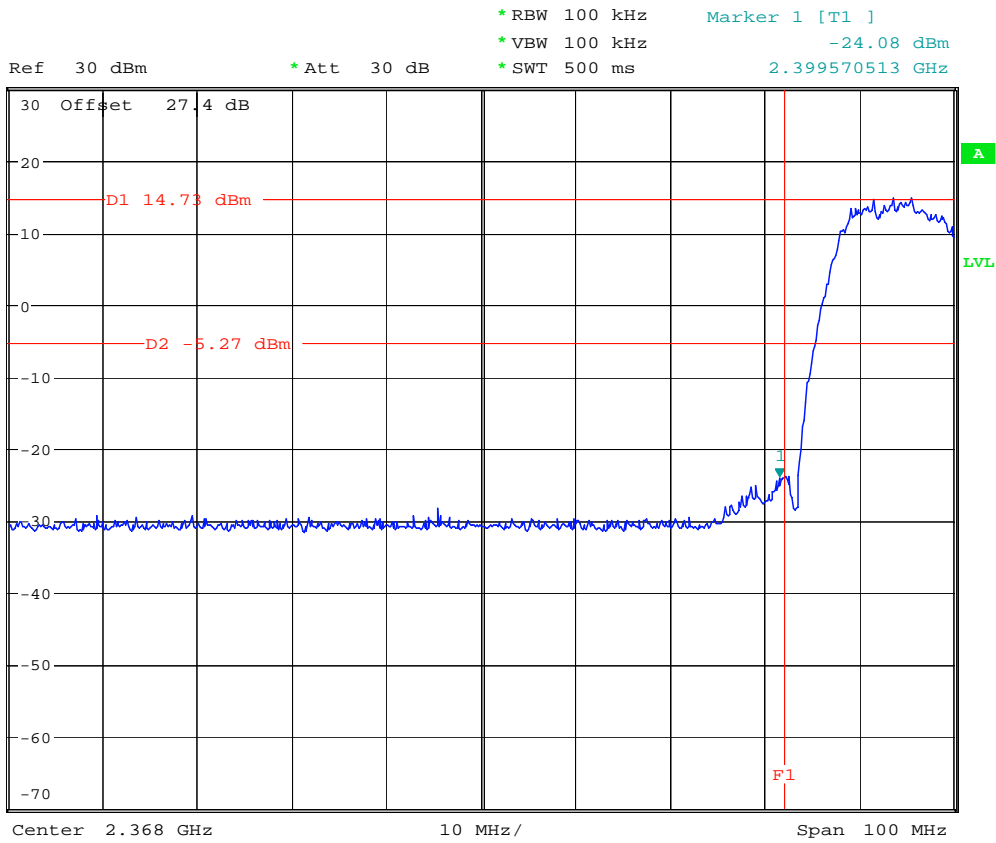

444

Date: 25.SEP.2007 22:01:53



CH11



Ref 30 dBm * Att 30 dB * RBW 100 kHz Marker 1 [T1]
* VBW 100 kHz -28.68 dBm
* SWT 500 ms 2.492858974 GHz

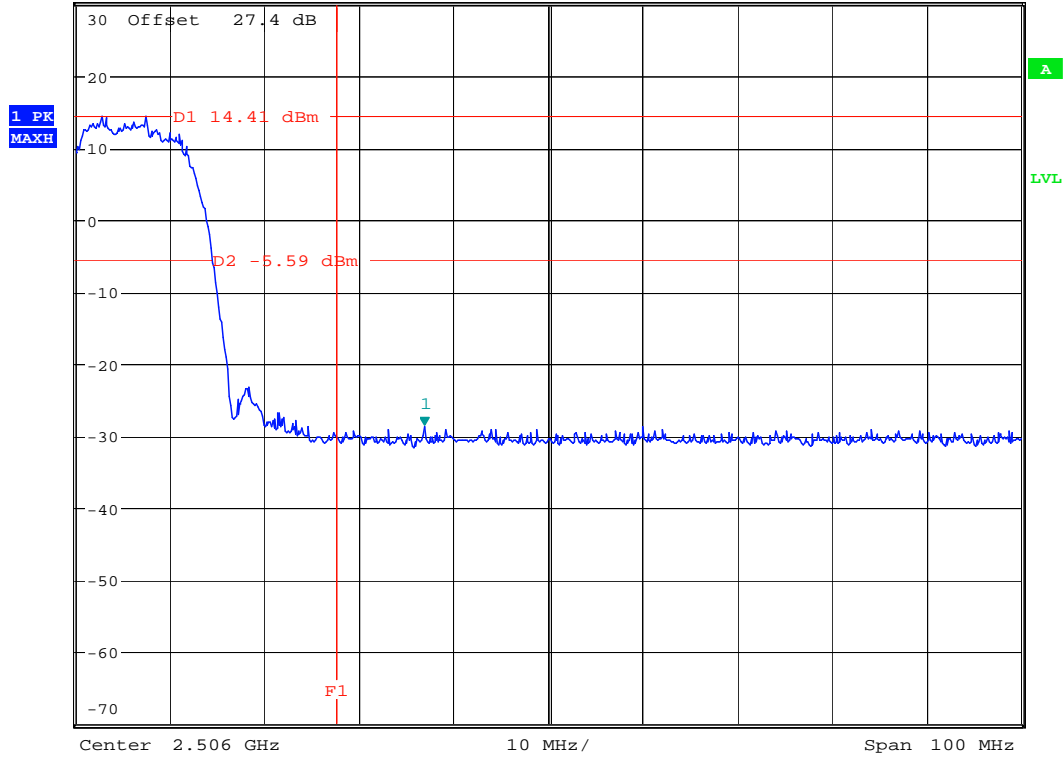

444

Date: 25.SEP.2007 22:04:10



WLAN 802.11g

CH01

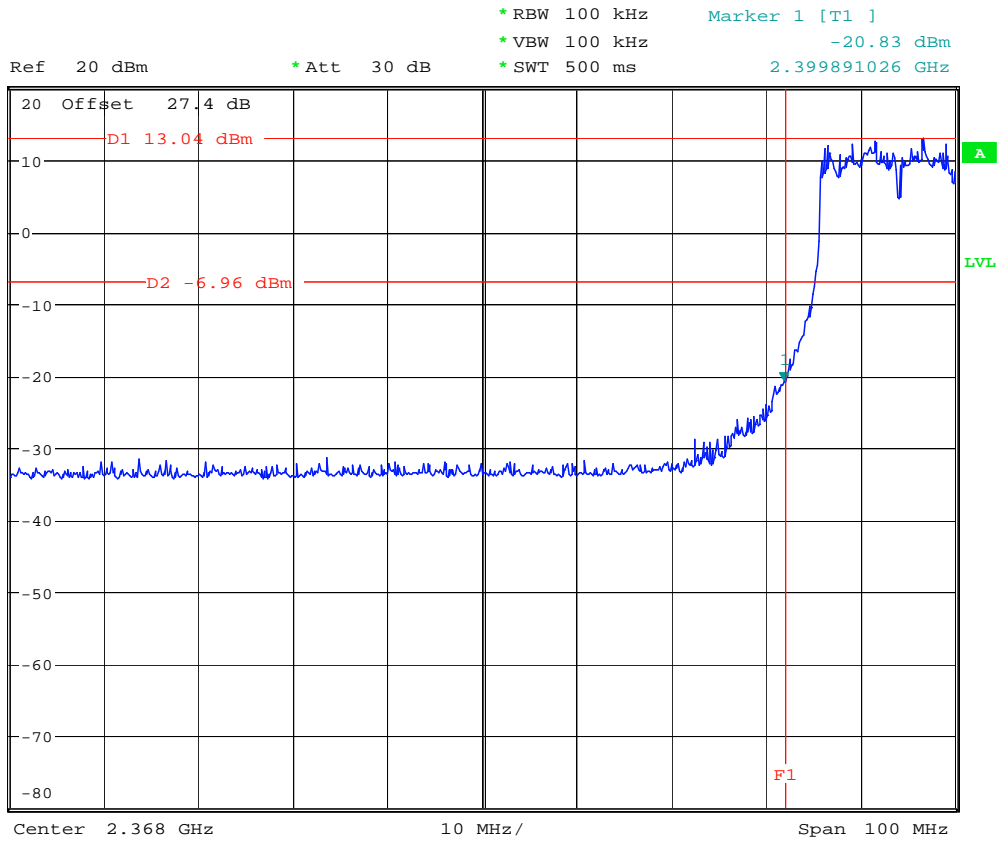

444

Date: 25.SEP.2007 20:52:24



CH11



Ref 20 dBm * Att 30 dB * RBW 100 kHz Marker 1 [T1]
* VBW 100 kHz -27.31 dBm
* SWT 500 ms 2.483884615 GHz

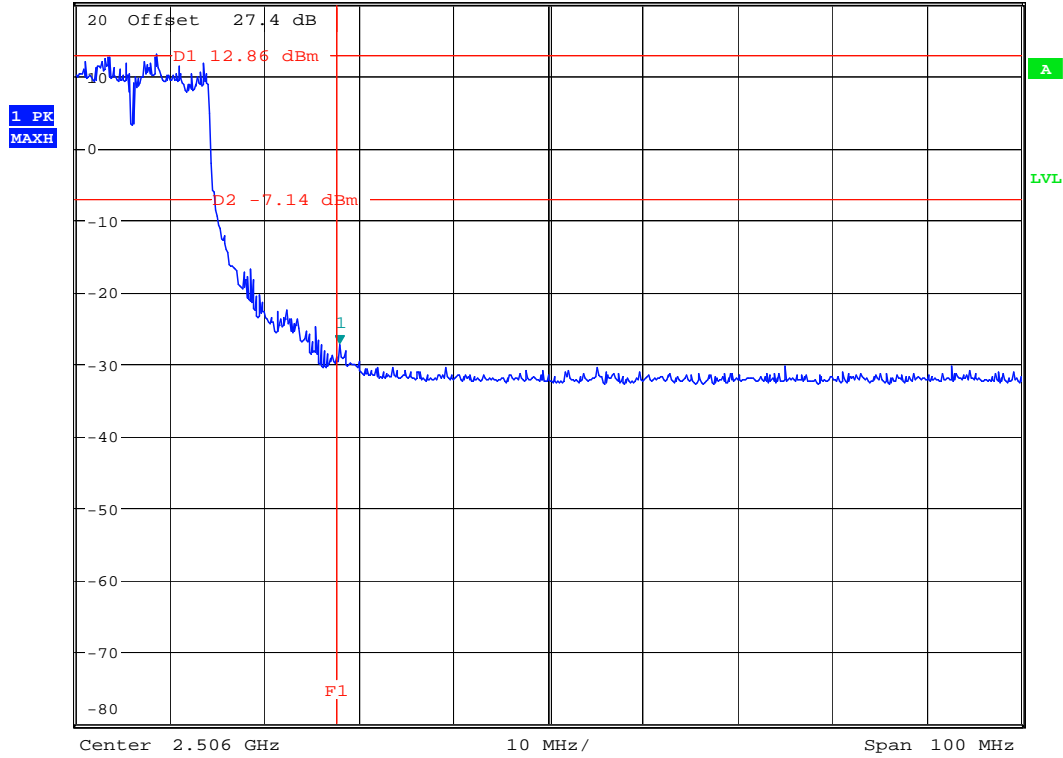

444

Date: 25.SEP.2007 20:50:22



WLAN 802.11a

CH0149



Ref 20 dBm *Att 20 dB *RBW 100 kHz Marker 1 [T1] -39.60 dBm
*VBW 100 kHz *SWT 500 ms 5.725000000 GHz

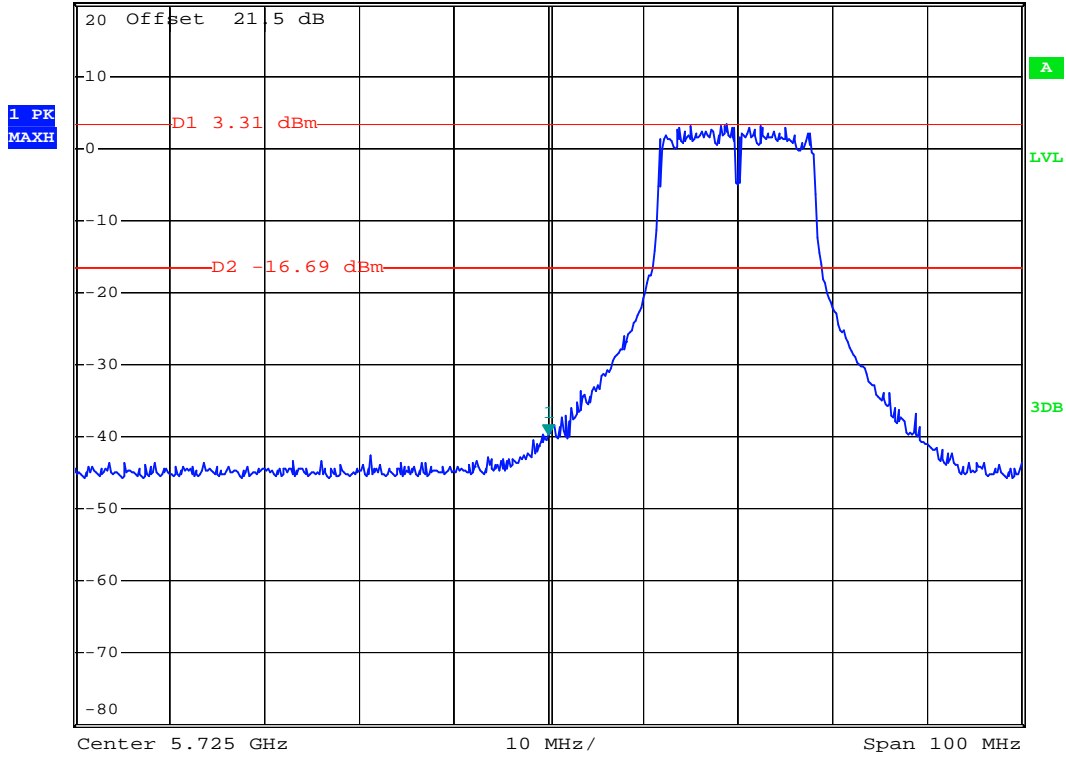

Date: 2.OCT.2007 12:24:07



CH165



*RBW 100 kHz Marker 1 [T1]
*VBW 100 kHz -43.76 dBm
*SWT 500 ms 5.88260000 GHz

Ref 20 dBm

*Att 20 dB

1 PR
MAXH

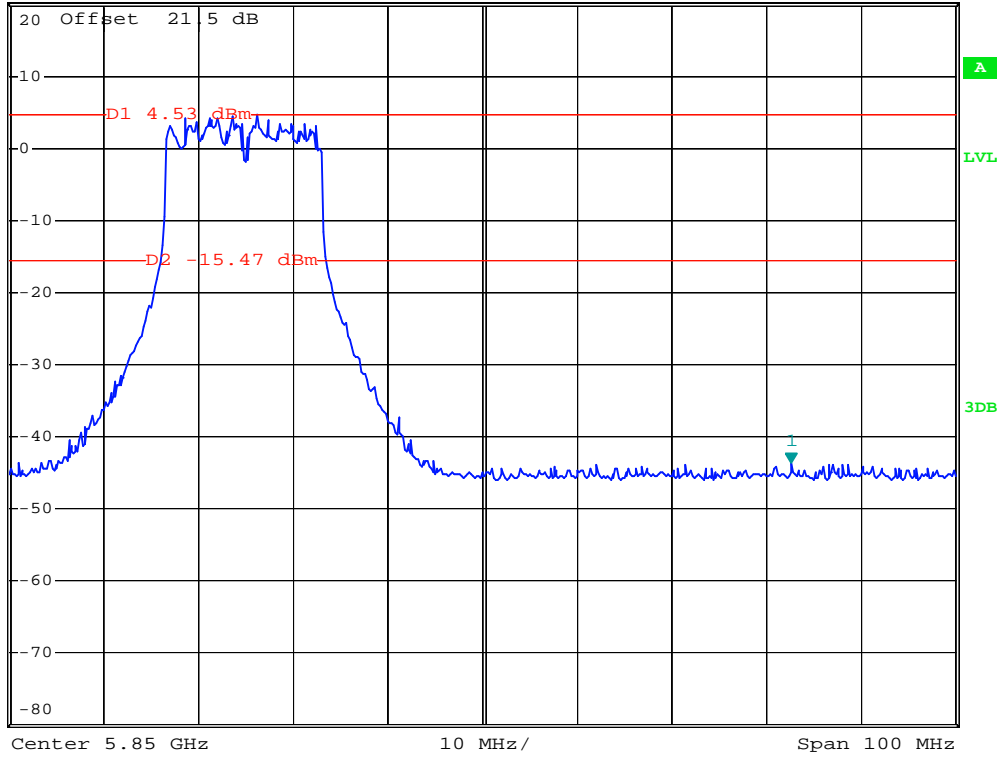

Date: 5.OCT.2007 20:13:54



WLAN 802.11n(g)_BW 20M

CH01



Ref 30 dBm *Att 30 dB *RBW 100 kHz Marker 1 [T1] -15.31 dBm
*VBW 100 kHz *SWT 500 ms 2.400000000 GHz

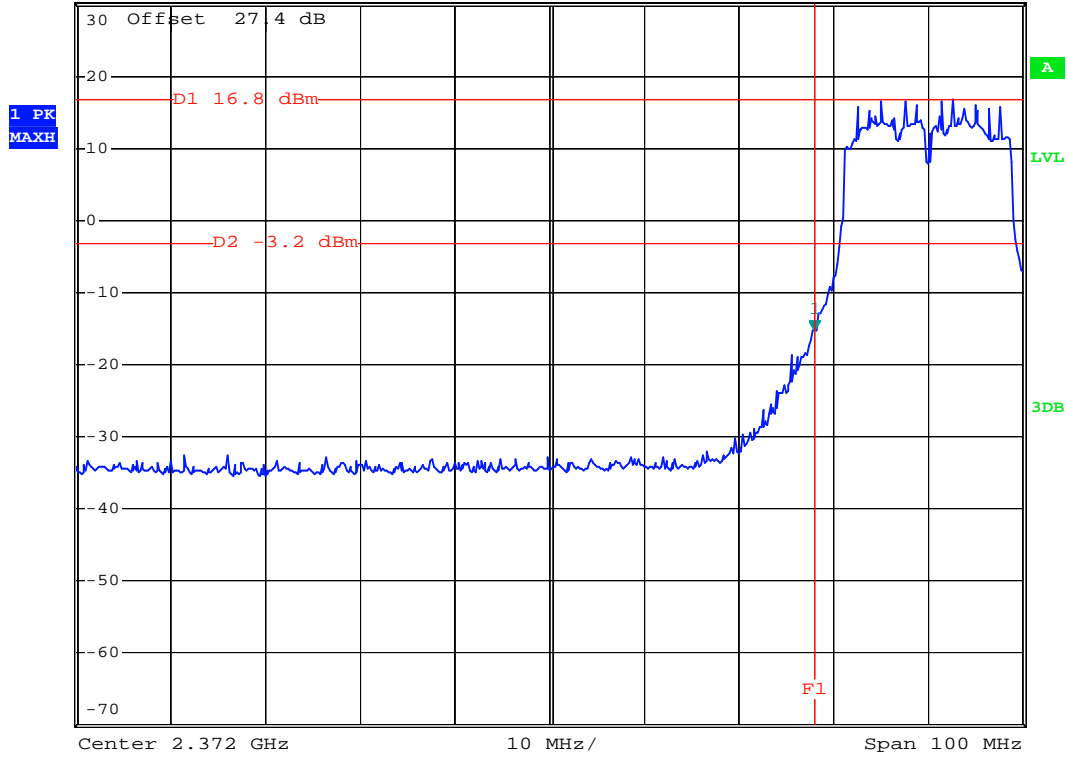

Date: 2.OCT.2007 17:10:39



CH11



Ref 30 dBm *Att 30 dB *RBW 100 kHz Marker 1 [T1] -33.73 dBm
*VBW 100 kHz *SWT 500 ms 2.48350000 GHz

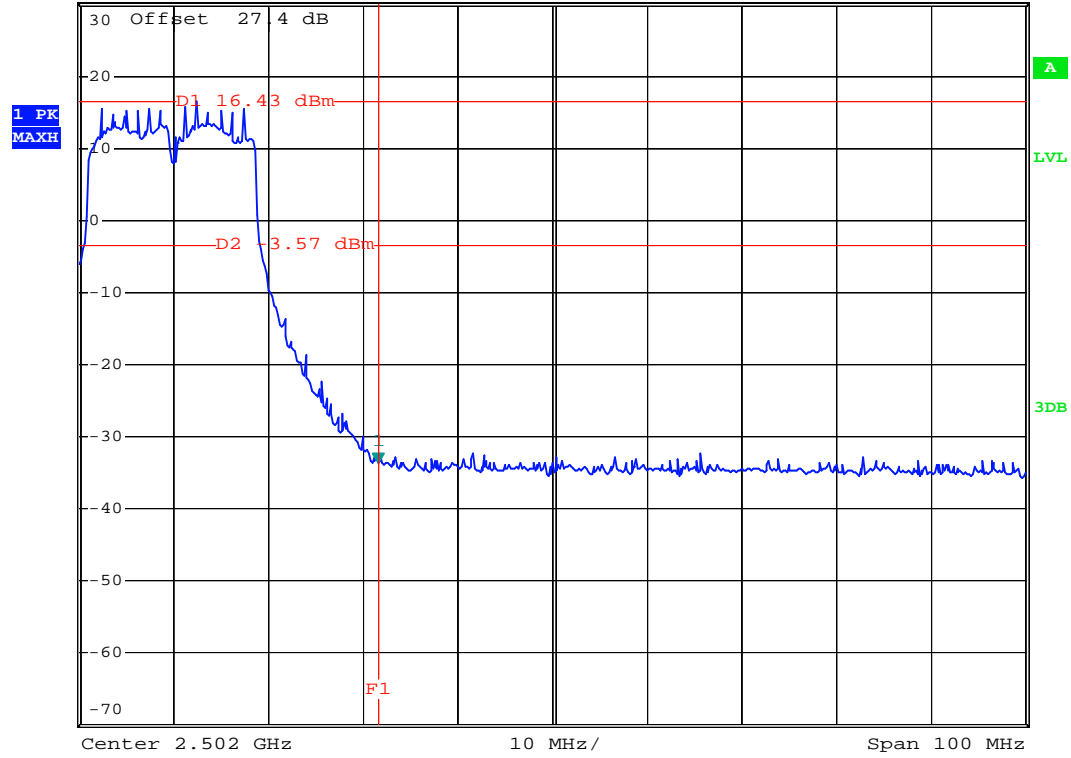

Date: 2.OCT.2007 17:09:22



WLAN 802.11n(g)_BW 40M

CH03



Ref 30 dBm *Att 30 dB *RBW 100 kHz Marker 1 [T1] -17.08 dBm
*VBW 100 kHz *SWT 500 ms 2.400000000 GHz

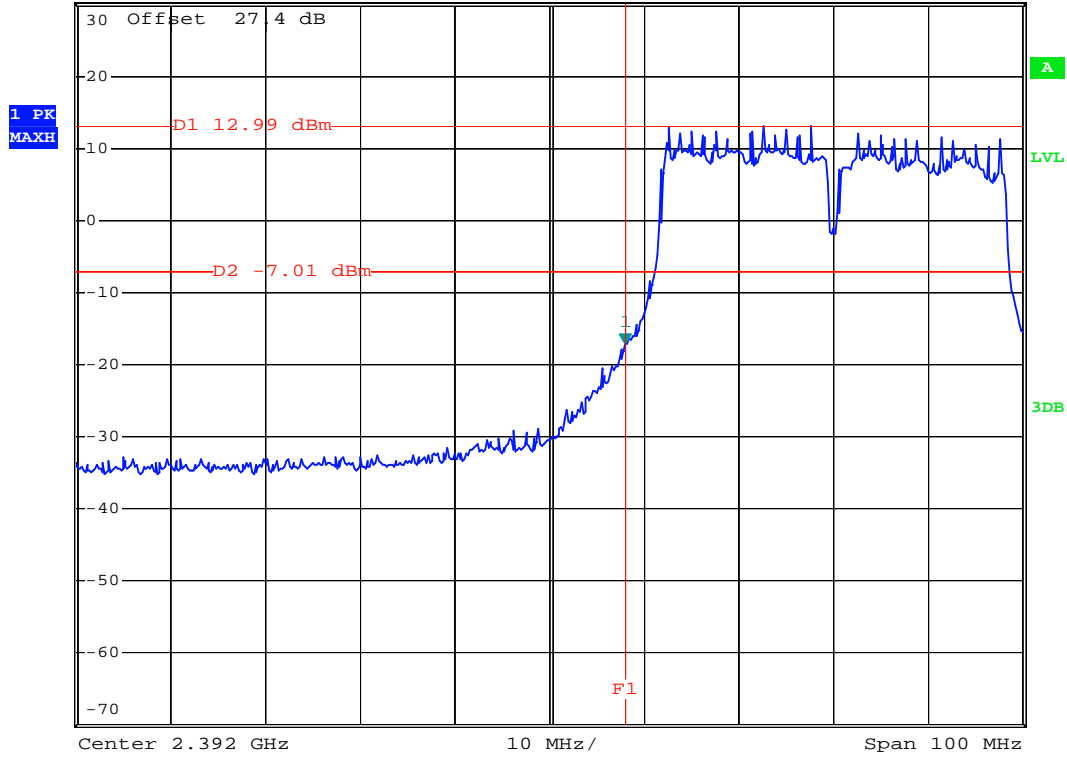

Date: 2.OCT.2007 18:33:23



CH09



Ref 30 dBm *Att 30 dB *RBW 100 kHz Marker 1 [T1] -32.18 dBm
*VBW 100 kHz
*SWT 500 ms 2.48350000 GHz

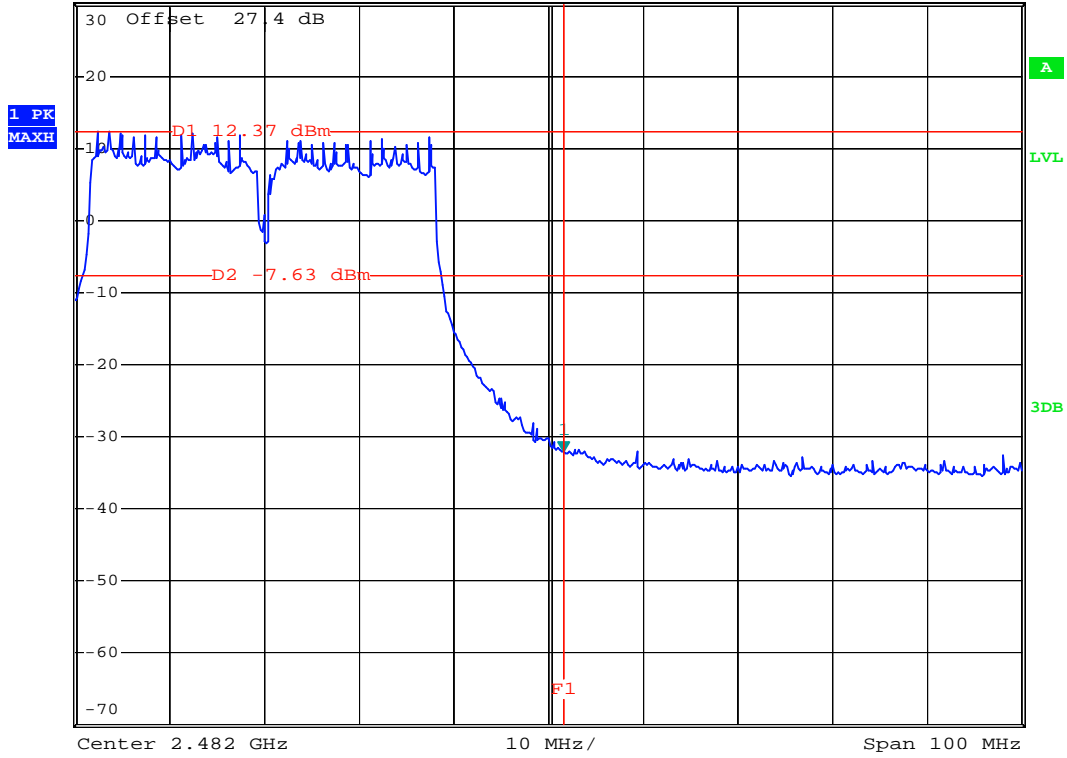

Date: 2.OCT.2007 18:31:56



WLAN 802.11n(a)_BW 20M

CH149



Ref 20 dBm *Att 20 dB *RBW 100 kHz Marker 1 [T1] -43.00 dBm
*VBW 100 kHz *SWT 500 ms 5.725000000 GHz

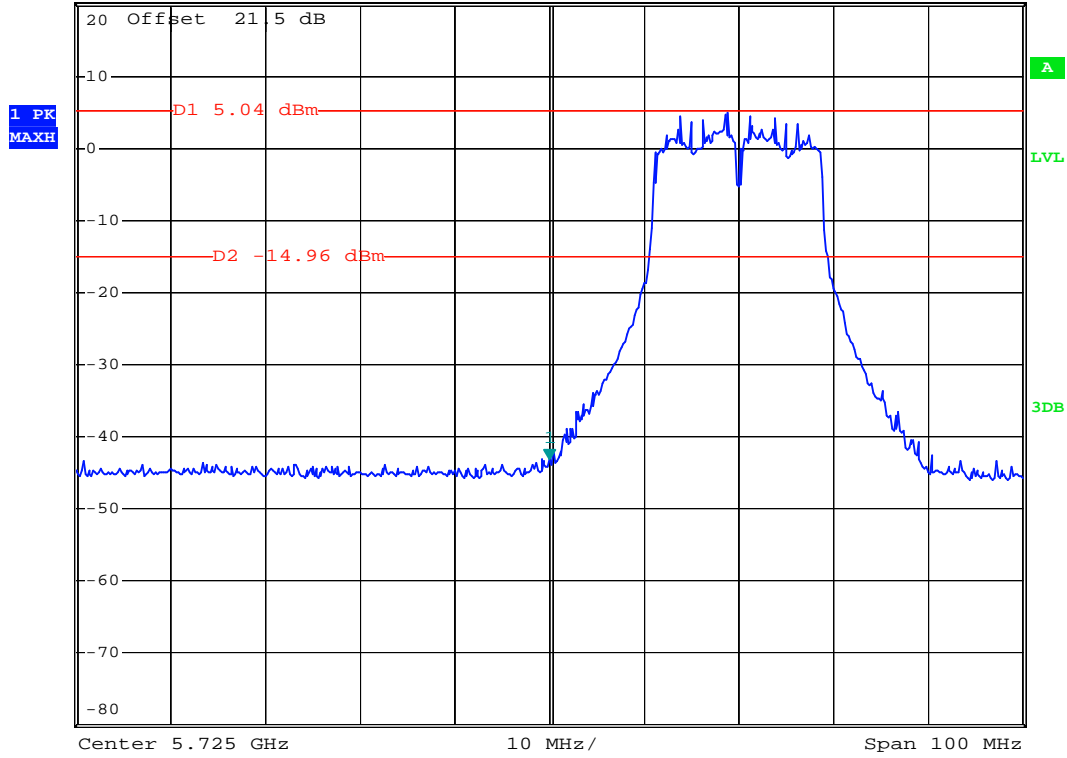

Date: 2.OCT.2007 15:24:11



CH165



*RBW 100 kHz Marker 1 [T1]
*VBW 100 kHz -43.38 dBm
*SWT 500 ms 5.856600000 GHz

Ref 20 dBm

*Att 20 dB

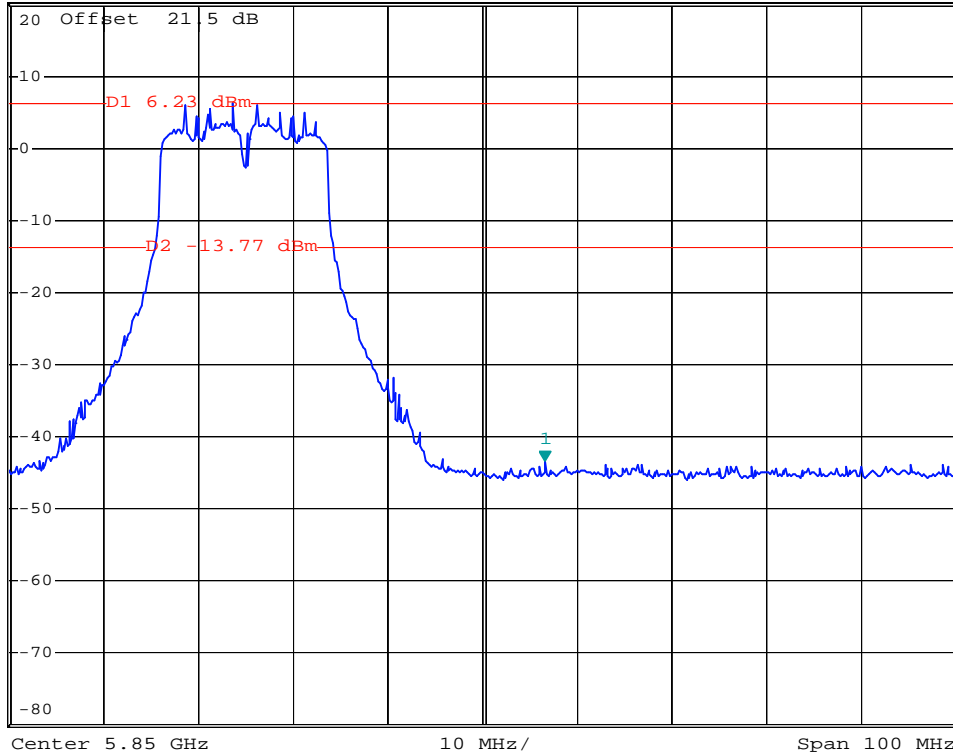

Date: 2.OCT.2007 15:20:57



WLAN 802.11n(a)_BW 40M

CH151

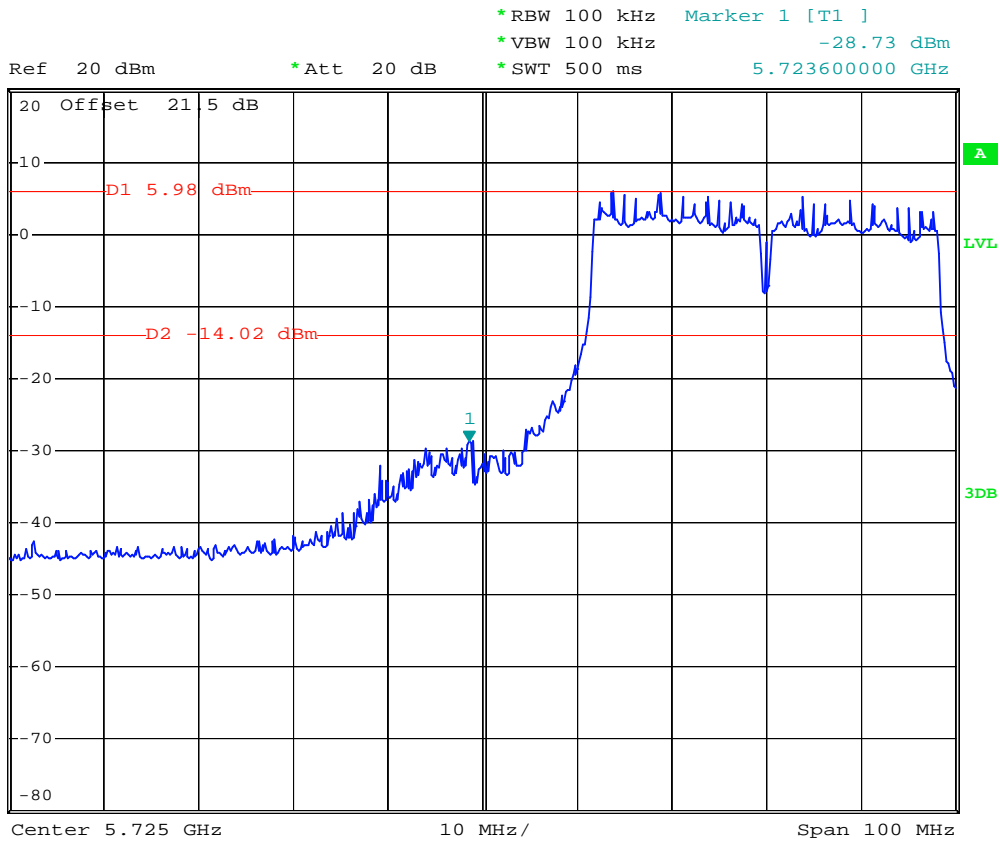

Date: 2.OCT.2007 16:20:53



CH159



*RBW 100 kHz Marker 1 [T1]
*VBW 100 kHz -43.75 dBm
*SWT 500 ms 5.875600000 GHz

Ref 20 dBm

*Att 20 dB

1 PR
VIEW

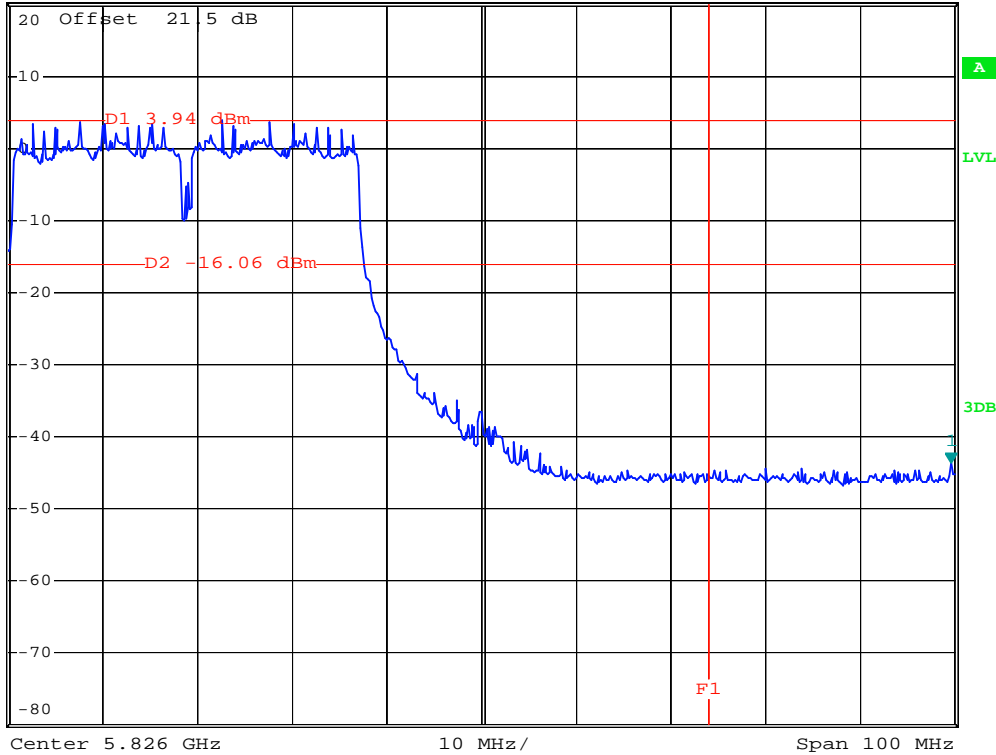

Date: 2.OCT.2007 16:24:41

5.5 Peak Output Power Measurement

5.5.1 Measuring Instruments :

As described in chapter 6 of this test report.

5.5.2 Test Procedure :

The antenna port (RF output) of the EUT was connected to the input (RF input) of a power meter for WLAN measurement. The power is equal to the reading level on power meter plus cable loss at the EUT antenna terminal.

5.5.3 Test Setup Layout :

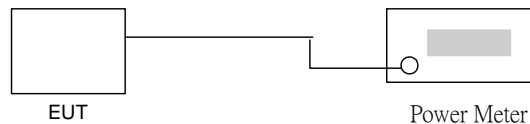

5.5.4 Test Result :

Application Type : WLAN 802.11b/g

Temperature : 25~26°C

Relative Humidity : 51~53%

Test Enginner : Sun

WLAN 802.11b

Channel	Frequency (MHz)	Measured Output Power (dBm)	Limits (Watt/dBm)
01	2412	16.16	1W/30 dBm
06	2437	16.79	1W/30 dBm
11	2462	17.01	1W/30 dBm

WLAN 802.11g

Channel	Frequency (MHz)	Measured Output Power (dBm)	Limits (Watt/dBm)
01	2412	20.92	1W/30 dBm
06	2437	21.57	1W/30 dBm
11	2462	21.84	1W/30 dBm

**WLAN 802.11a**

Channel	Frequency (MHz)	Measured Output Power (dBm)	Limits (Watt/dBm)
149	5745	21.74	1W/30 dBm
157	5785	21.75	1W/30 dBm
165	5825	21.95	1W/30 dBm

WLAN 802.11n(g)_BW 20M

Channel	Frequency (MHz)	Measured Output Power (dBm)	Limits (Watt/dBm)
01	2412	24.55	1W/30 dBm
06	2437	25.13	1W/30 dBm
11	2462	25.66	1W/30 dBm

WLAN 802.11n(g)_BW 40M

Channel	Frequency (MHz)	Measured Output Power (dBm)	Limits (Watt/dBm)
03	2422	23.56	1W/30 dBm
09	2452	22.73	1W/30 dBm

WLAN 802.11n(a)_BW 20M

Channel	Frequency (MHz)	Measured Output Power (dBm)	Limits (Watt/dBm)
149	5745	25.76	1W/30 dBm
157	5785	25.49	1W/30 dBm
165	5825	26.64	1W/30 dBm

WLAN 802.11n(a)_BW 40M

Channel	Frequency (MHz)	Measured Output Power (dBm)	Limits (Watt/dBm)
151	5755	23.34	1W/30 dBm
159	5795	23.23	1W/30 dBm



5.6 Conducted Emission

5.6.1 Measuring Instruments

As described in chapter 6 of this test Report.

5.6.2 Test Procedures :

- a. The EUT was placed 0.4 meter from the conducting wall of the shielding room was kept at least 80 centimeters from any other grounded conducting surface.
- b. Connect EUT to the power port of a line impedance stabilization network (LISN).
- c. All the support units are connected to the other LISN.
- d. The LISN provides 50 ohm coupling impedance for the measuring instrument.
- e. The FCC states that a 50 ohm, 50 microhenry LISN should be used.
- f. Both sides of AC line were checked for maximum conducted interference.
- g. The frequency range from 150 kHz to 30 MHz was searched.
- h. Set the test-receiver system to Peak Detect Function and specified bandwidth with Maximum Hold Mode.



5.6.3 Test Data

Temperature : 25~26°C
 Relative Humidity : 51~53%
 Test Enginner : Win
 Test Mode : Mode 1

■ The test that passed at minimum margin was marked by the frame in the following table.

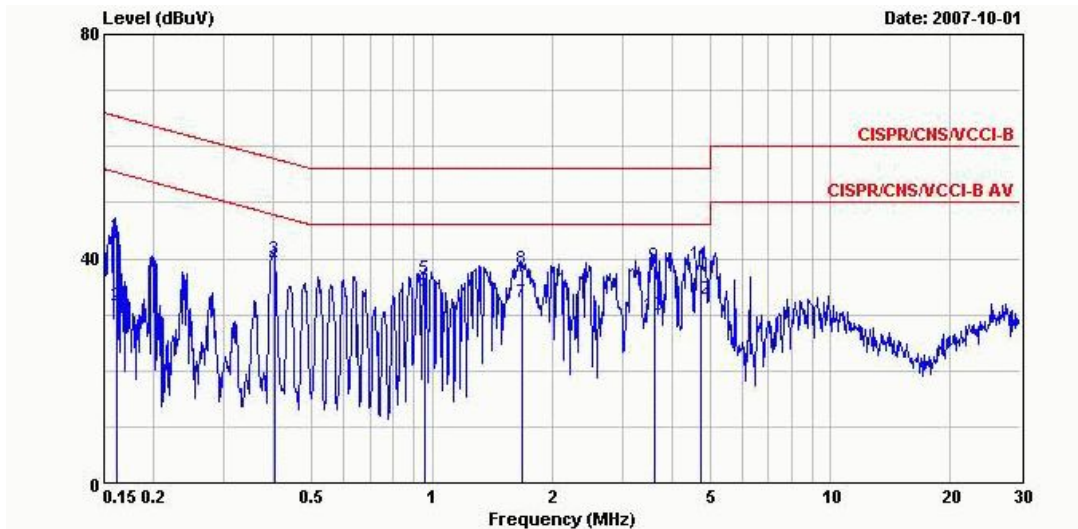

Site : CO04-HY
 Condition : CISPR/CNS/VCCI-B LISN 200704 99041 LINE
 EUT : AP
 Power : 120Vac/60Hz
 Model : FR 791302
 Memo : WLAN Link+LAN+Adaptor

	Freq	Level	Over	Limit	Read	LISN	Cable	
	MHz	dBuV	Limit	Line	Level	Factor	Loss	Remark
			dB	dBuV	dBuV	dB	dB	
1	0.1615020	44.16	-21.23	65.39	43.92	0.10	0.14	QP
2	0.1615020	31.60	-23.79	55.39	31.36	0.10	0.14	Average
3	0.4018680	39.86	-17.95	57.81	39.03	0.10	0.73	QP
4	0.4018680	38.69	-9.12	47.81	37.86	0.10	0.73	Average
5	0.9581900	36.54	-19.46	56.00	35.98	0.10	0.46	QP
6	0.9581900	34.25	-11.75	46.00	33.69	0.10	0.46	Average
7	1.683	32.06	-13.94	46.00	31.53	0.10	0.43	Average
8	1.683	38.01	-17.99	56.00	37.48	0.10	0.43	QP
9	3.626	38.68	-17.32	56.00	38.24	0.10	0.34	QP
10	3.626	29.80	-16.20	46.00	29.36	0.10	0.34	Average
11	4.746	38.91	-17.09	56.00	38.49	0.12	0.30	QP
12	4.746	32.84	-13.16	46.00	32.42	0.12	0.30	Average

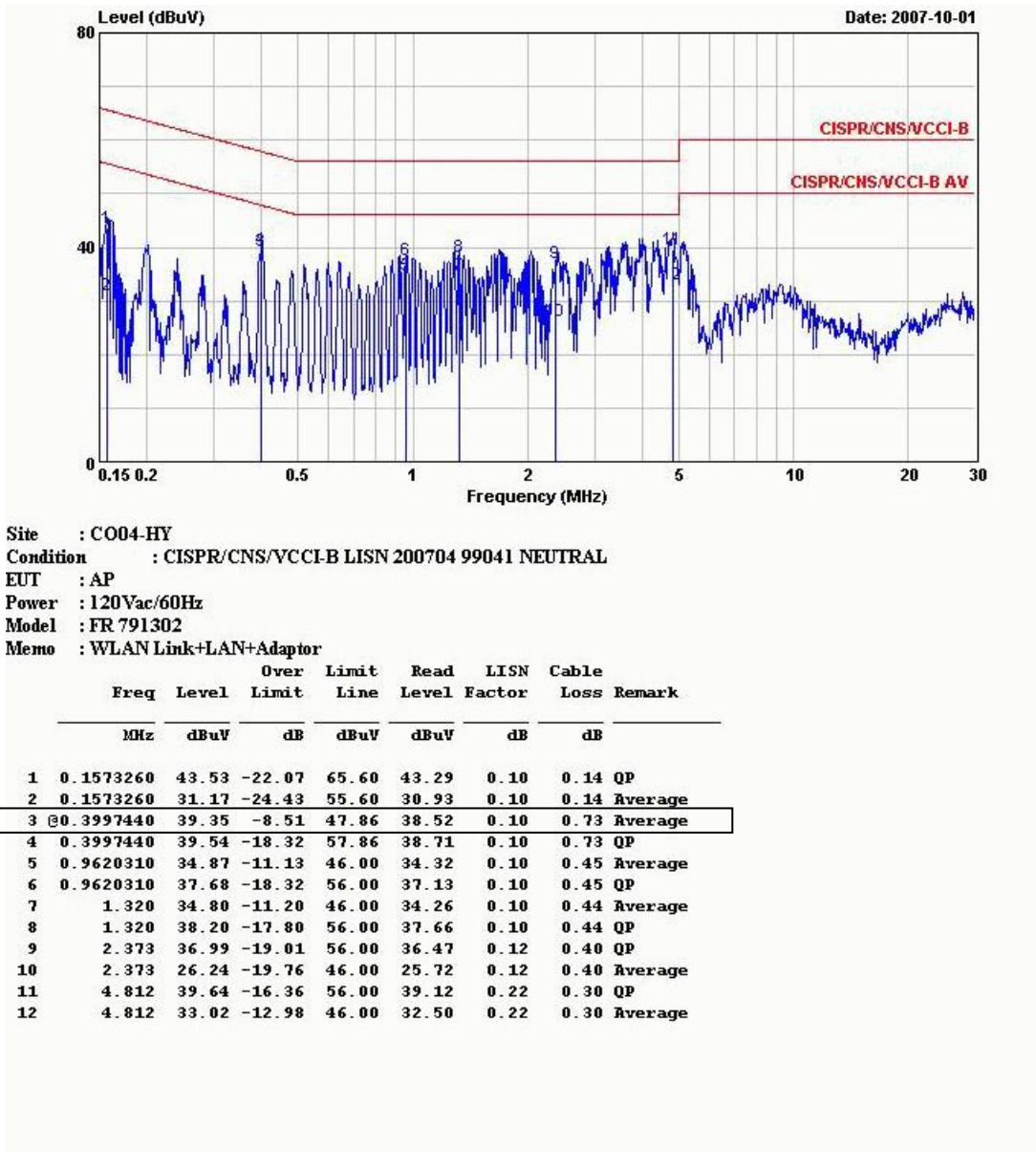



Temperature : 25~26°C
Relative Humidity : 51~53%
Test Enginner : Win
Test Mode : Mode 2

The test that passed at minimum margin was marked by the frame in the following table.

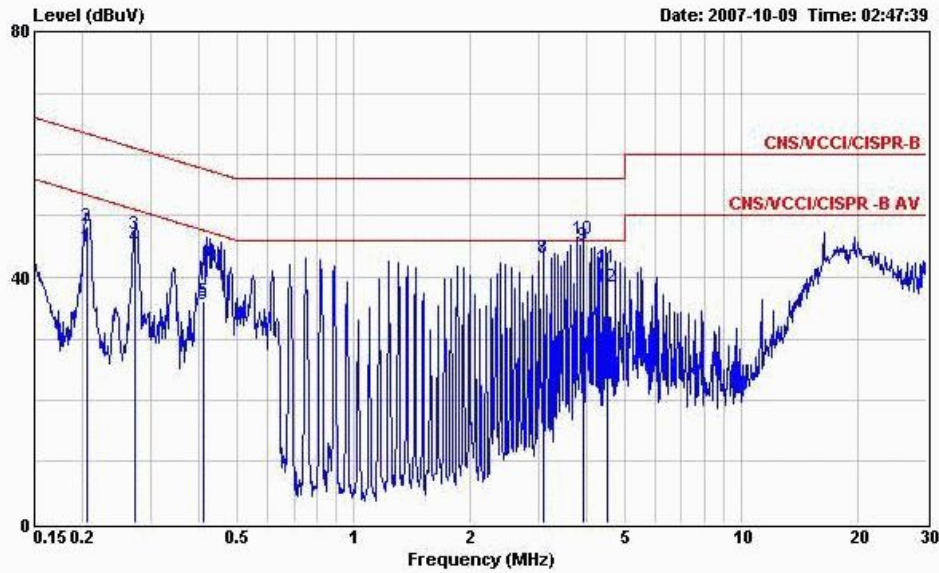

Site : CO04-HY
Condition : CNS/VCCI/CISPR-B 2001/004 200604 LINE
EUT : AP
Power : 120Vac/60Hz
Power : FD 791302
Memo : WLAN Link+POE+LAN+Adaptor

Freq	Level	Over Limit	Limit Line	Read Level	Cable Loss	Probe Factor	Remark
MHz	dBuV	dB	dBuV	dBuV	dB	dB	
1	0.206	45.03	-8.34	53.37	44.85	0.08	0.10 Average
2	0.206	48.42	-14.95	63.37	48.24	0.08	0.10 QP
3	0.273	47.09	-13.94	61.03	46.89	0.10	0.10 QP
4	0.273	44.91	-6.12	51.03	44.71	0.10	0.10 Average
5	0.411	36.10	-21.53	57.63	35.88	0.12	0.10 QP
6	0.411	35.58	-12.05	47.63	35.36	0.12	0.10 Average
7	3.080	43.11	-12.89	56.00	42.69	0.26	0.16 QP
8	3.080	42.99	-3.01	46.00	42.57	0.26	0.16 Average
9	3.900	45.16	-0.84	46.00	44.63	0.33	0.20 Average
10	3.900	46.26	-9.74	56.00	45.73	0.33	0.20 QP
11	4.514	41.53	-14.47	56.00	40.99	0.33	0.21 QP
12	4.514	38.37	-7.63	46.00	37.83	0.33	0.21 Average

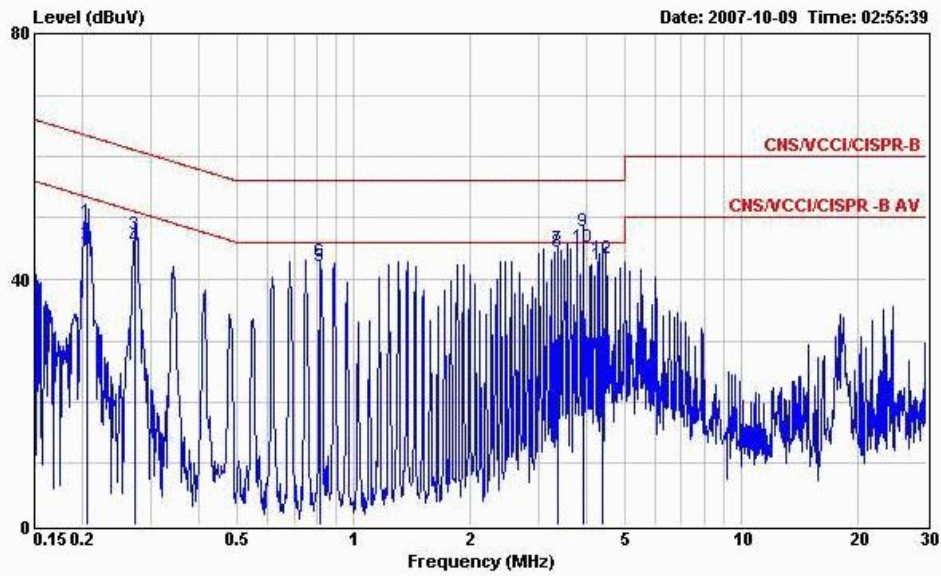

Site : C004-HY
 Condition : CNS/VCCI/CISPR-B 2001/004 200604 NEUTRAL
 EUT : AP
 Power : 120Vac/60Hz
 Power : FR 791302
 Memo : WLAN Link+POE+LAN+Adaptor

Freq	Level	Limit	Over	Limit	Read	Cable	Probe	Remark
MHz	dBuV	dB	dBuV	dBuV	dB	dB		
1	0.206	49.33	-14.04	63.37	49.15	0.08	0.10	QP
2	0.206	45.82	-7.55	53.37	45.64	0.08	0.10	Average
3	0.272	47.36	-13.70	61.06	47.16	0.10	0.10	QP
4	0.272	45.22	-5.84	51.06	45.02	0.10	0.10	Average
5	0.822	42.17	-13.83	56.00	41.91	0.16	0.10	QP
6	0.822	42.94	-3.06	46.00	42.68	0.16	0.10	Average
7	3.350	44.87	-11.13	56.00	44.48	0.29	0.10	QP
8	3.350	44.30	-1.70	46.00	43.91	0.29	0.10	Average
9	3.900	47.74	-8.26	56.00	47.31	0.33	0.10	QP
10	3.900	45.07	-0.93	46.00	44.64	0.33	0.10	Average
11	4.380	42.25	-3.75	46.00	41.81	0.33	0.11	Average
12	4.380	43.49	-12.51	56.00	43.05	0.33	0.11	QP



5.7 Radiated Emission Measurement

5.7.1 Measuring Instruments

As described in chapter 6 of this Report.

5.7.2 Test Procedures

- a. The EUT was placed on a rotatable table top 0.8 meter above ground.
- b. The EUT was set 3 meters from the interference receiving antenna which was mounted on the top of a variable height antenna tower.
- c. The table was rotated 360 degrees to determine the position of the highest radiation.
- d. The antenna is a broadband antenna and its height is varied between one meter and four meters above ground to find the maximum value of the field strength for both horizontal polarization and vertical polarization of the antenna.
- e. For each suspected emission, the EUT was arranged to its worst case and then tune the antenna tower (from 1 m to 4 m) and turntable (from 0 degree to 360 degrees) to find the maximum reading.
- f. Set the test-receiver system to Peak or CISPR quasi-peak Detect Function and specified bandwidth with Maximum Hold Mode.
- g. For testing below 1GHz, If the emission level of the EUT in peak mode was 3 dB lower than the limit specified, then testing will be stopped and peak values of EUT will be reported, otherwise, the emissions will be repeated one by one using the quasi-peak method and reported.
- h. For testing above 1GHz, the emission level of the EUT in peak mode was 20dB lower than average limit (that means the emission level in average mode also complies with the limit in average mode), then testing will be stopped and peak values of EUT will be reported, otherwise, the emissions will be measured in average mode again and reported.

5.7.3 Typical Test Setup Layout of Radiated Emission

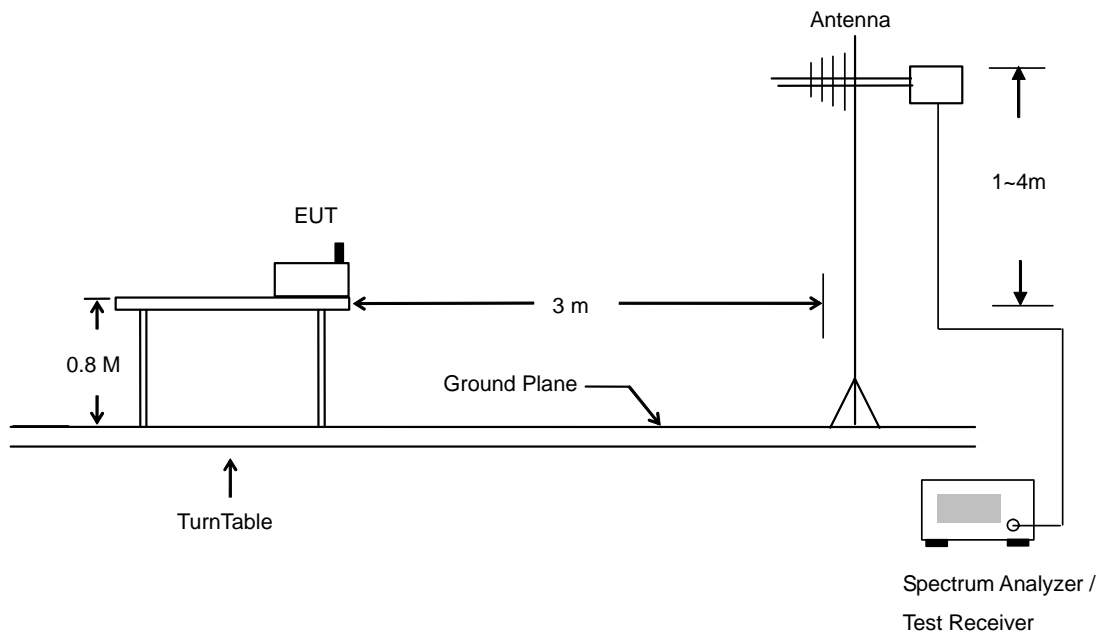



5.7.4 Test Data

Temperature : 25~26°C
 Relating Humidity : 52~54%
 Test Enginner : Andrew
 Test Mode : Mode 1
 Polarization : Horizontal (30MHz-1GHz)

The test that passed at minimum margin was marked by the boldface in the following table.

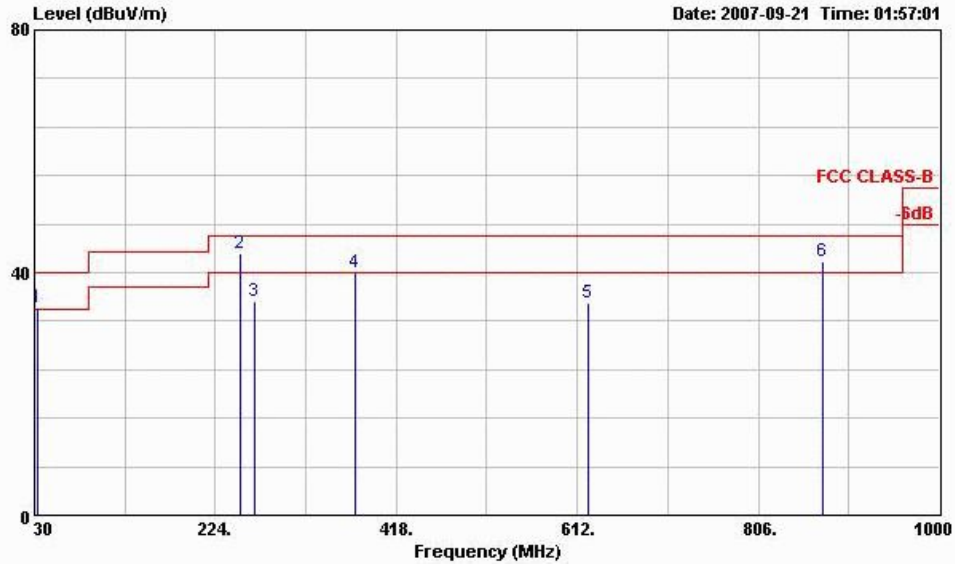

Site : 03CH04-HY
 Condition: FCC CLASS-B 3m ANT2724 HORIZONTAL
 EUT : AP
 POWER : 120Vac/60Hz
 MODEL : FR 791302
 MOMENT : 11b Tx_Ch01;2412MHz
 Data Rate: 5.5

	Freq	Level	Over	Limit	ReadAntenna	Cable	Preamp	Ant	Table		
	MHz	dBuV/m	Limit	Line	Level	Factor	Loss	Factor	Pos	Table	
			dB	dBuV/m	dBuV	dB/m	dB	dB	cm	deg	
1 !	32.700	34.08	-5.92	40.00	43.52	16.33	0.90	26.66	---	---	Peak
2 !	250.050	43.27	-2.73	46.00	54.56	12.57	2.05	25.91	100	246	QP
3	266.250	35.34	-10.66	46.00	46.60	12.48	2.11	25.85	---	---	Peak
4 !	374.200	40.11	-5.89	46.00	48.98	14.88	2.49	26.24	---	---	Peak
5	624.100	34.96	-11.04	46.00	38.78	19.96	3.26	27.04	---	---	Peak
6 !	875.400	41.80	-4.20	46.00	41.93	22.62	3.92	26.67	---	---	Peak



Polarization : Horizontal (1GHz-25GHz)

The test that passed at minimum margin was marked by the boldface in the following table.

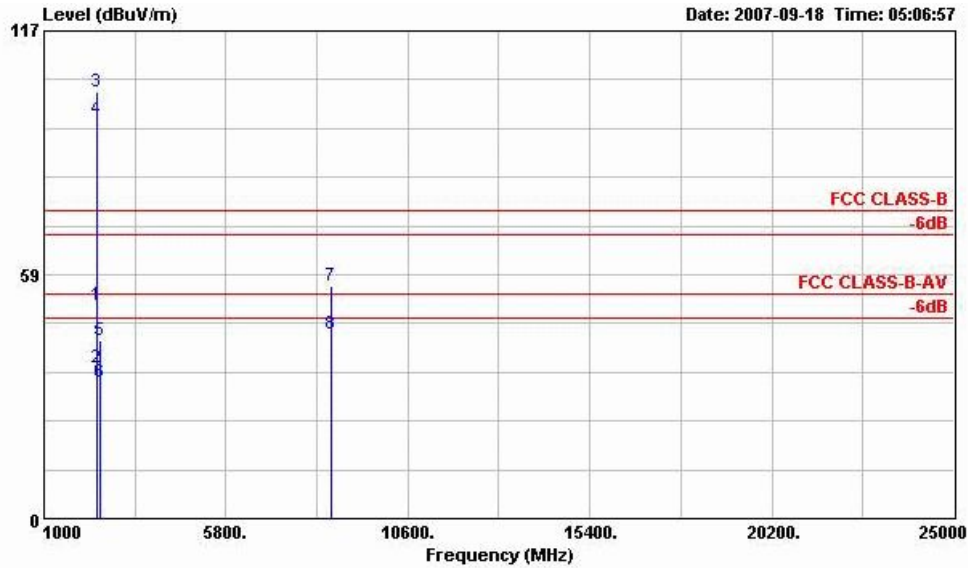

Site : 03CH04-HY
 Condition: FCC CLASS-B 3m HF-ANT-6903 HORIZONTAL
 EUT : AP
 POWER : 120Vac/60Hz
 MODEL : FR 791302
 MOME : 11b Tx_Ch01;2412MHz
 Data Rate: 5.5

	Freq	Level	Over	Limit	ReadAntenna	Cable	Preamp	Ant	Table	Remark
	MHz	dBuV/m	dB	dBuV/m	dBuV	dB/m	dB	dB	cm	deg
1	2386.380	51.25	-22.75	74.00	53.21	28.07	3.74	33.78	100	0 Peak
2	2386.380	36.17	-17.83	54.00	38.13	28.07	3.74	33.78	100	289 Average
3 X	2412.000	102.45			104.36	28.11	3.76	33.78	100	0 Peak
4 X	2412.000	95.64			97.55	28.11	3.76	33.78	100	289 Average
5	2500.000	42.62	-31.38	74.00	44.28	28.30	3.84	33.80	100	0 Peak
6	2500.000	32.61	-21.39	54.00	34.27	28.30	3.84	33.80	100	289 Average
7	8574.000	55.72	-18.28	74.00	45.52	37.60	7.06	34.46	100	0 Peak
8	8574.000	44.35	-9.65	54.00	34.15	37.60	7.06	34.46	100	12 Average

Remark:

1. "3" represents the Fundamental Signal
2. "4" represents the Fundamental Signal



Polarization : Vertical (30MHz-1GHz)

The test that passed at minimum margin was marked by the boldface in the following table.

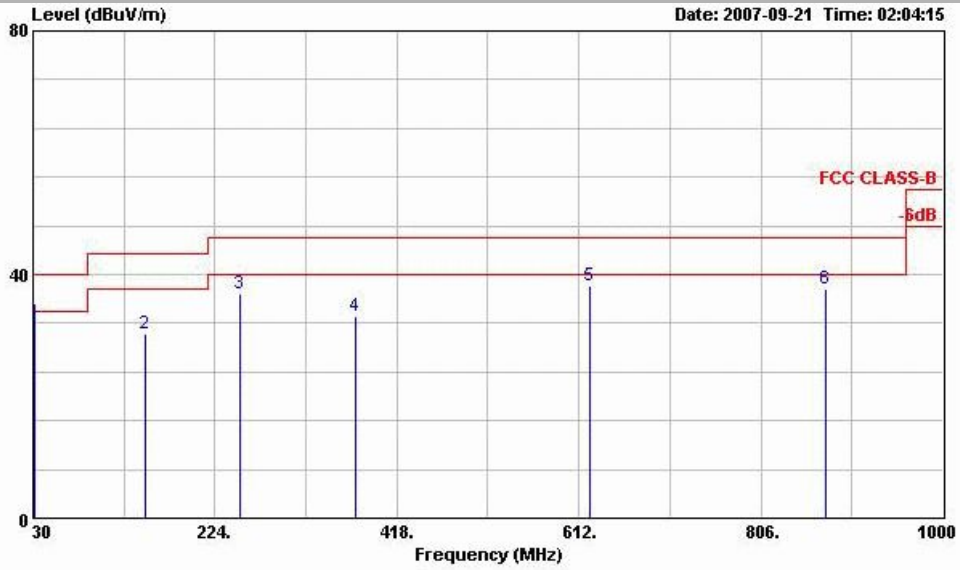

Site : 03CH04-HY
 Condition: FCC CLASS-B 3m ANT2724 VERTICAL
 EUT : AP
 POWER : 120Vac/60Hz
 MODEL : FR 791302
 MOME : 11b Tx_Ch01;2412MHz
 Data Rate: 5.5

	Freq	Level	Over	Limit	ReadAntenna	Cable	Preamp	Ant	Table	
	MHz	dBuV/m	Limit	Line	Level	Loss	Factor	Pos	Pos	Remark
			dB	dBuV/m	dBuV	dB	dB	cm	deg	
1	31.890	35.38	-4.62	40.00	44.81	16.34	0.89	26.66	100	202 QP
2	149.340	30.31	-13.19	43.50	44.18	10.75	1.66	26.28	---	--- Peak
3	250.050	36.82	-9.18	46.00	48.11	12.57	2.05	25.91	---	--- Peak
4	374.200	33.13	-12.87	46.00	42.00	14.88	2.49	26.24	---	--- Peak
5	624.100	38.06	-7.94	46.00	41.88	19.96	3.26	27.04	---	--- Peak
6	875.400	37.61	-8.39	46.00	37.74	22.62	3.92	26.67	---	--- Peak



Polarization : Vertical (1GHz-25GHz)

The test that passed at minimum margin was marked by the boldface in the following table.

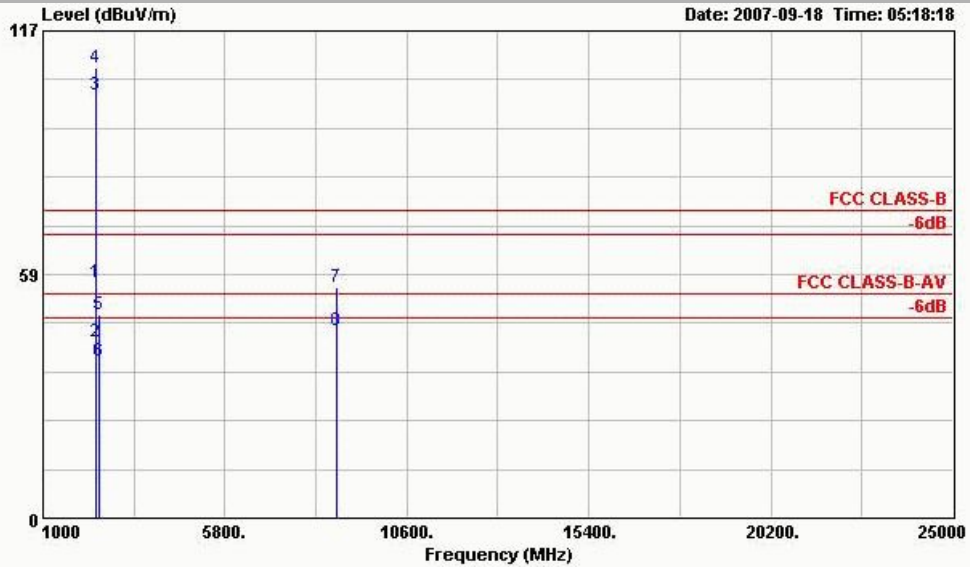

Site : 03CH04-HY
 Condition: FCC CLASS-B 3m HF-ANT-6903 VERTICAL
 EUT : AP
 POWER : 120Vac/60Hz
 MODEL : FR 791302
 MOME : 11b Tx_Ch01;2412MHz
 Data Rate: 5.5

	Freq	Level	Over	Limit	Read	Antenna	Cable	Preamp	Ant	Table	
	MHz	dBuV/m	dB	dBuV/m	Level	Factor	Loss	Factor	Pos	Pos	Remark
					dBuV	dB/m	dB	dB	cm	deg	
1	2386.380	56.51	-17.49	74.00	58.47	28.07	3.74	33.78	100	0	Peak
2	2386.380	42.28	-11.72	54.00	44.24	28.07	3.74	33.78	100	112	Average
3 @	2412.000	101.73			103.64	28.11	3.76	33.78	100	112	Average
4 X	2412.000	108.03			109.94	28.11	3.76	33.78	100	0	Peak
5	2484.000	48.69	-25.31	74.00	50.39	28.26	3.84	33.80	100	0	Peak
6	2484.000	37.64	-16.36	54.00	39.34	28.26	3.84	33.80	100	112	Average
7	8745.000	55.39	-18.61	74.00	45.04	37.80	7.15	34.60	100	0	Peak
8	8745.000	45.21	-8.79	54.00	34.86	37.80	7.15	34.60	100	9	Average

Remark:

1. "3" represents the Fundamental Signal
2. "4" represents the Fundamental Signal



Test Mode : Mode 2
Polarization : Horizontal (30MHz-1GHz)

■ The test that passed at minimum margin was marked by the boldface in the following table.

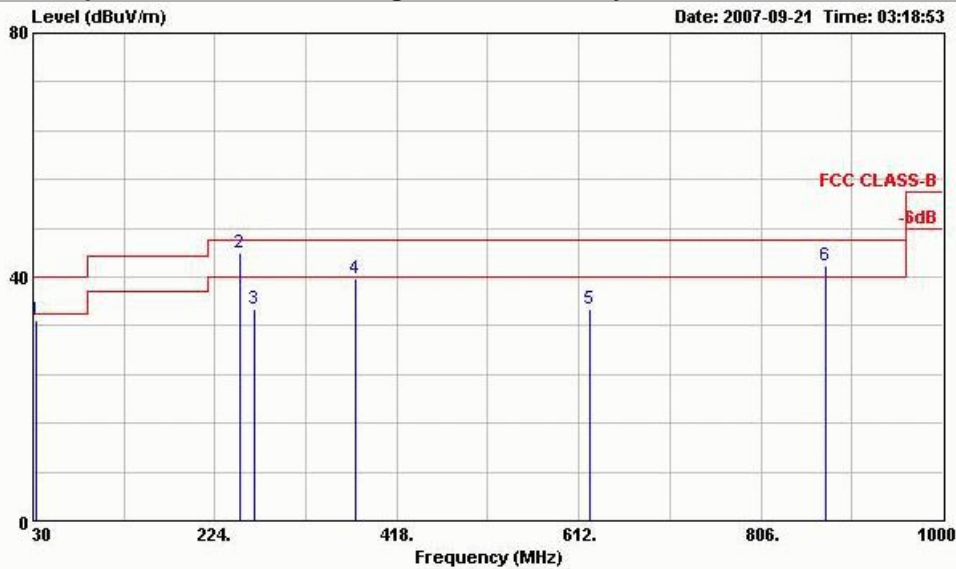

Site : 03CH04-HY
Condition: FCC CLASS-B 3m ANT2724 HORIZONTAL
EUT : AP
POWER : 120Vac/60Hz
MODEL : FR 791302
MOME : 11b Tx_Ch06;2437MHz
Data Rate: 5.5

	Freq	Level	Over	Limit	ReadAntenna	Cable	Preamp	Ant	Table		
	MHz	dBuV/m	Limit	Line	Level	Factor	Loss	Factor	Pos	Pos	
			dB	dBuV/m	dBuV	dB/m	dB	dB	cm	deg	
1	32.700	33.02	-6.98	40.00	42.46	16.33	0.90	26.66	---	---	Peak
2 @	250.050	43.87	-2.13	46.00	55.16	12.57	2.05	25.91	100	251	QP
3	266.250	34.69	-11.31	46.00	45.95	12.48	2.11	25.85	---	---	Peak
4	374.200	39.82	-6.18	46.00	48.69	14.88	2.49	26.24	---	---	Peak
5	624.100	34.74	-11.26	46.00	38.56	19.96	3.26	27.04	---	---	Peak
6 !	875.400	41.89	-4.11	46.00	42.02	22.62	3.92	26.67	---	---	Peak



Polarization : Horizontal (1GHz-25GHz)

The test that passed at minimum margin was marked by the boldface in the following table.

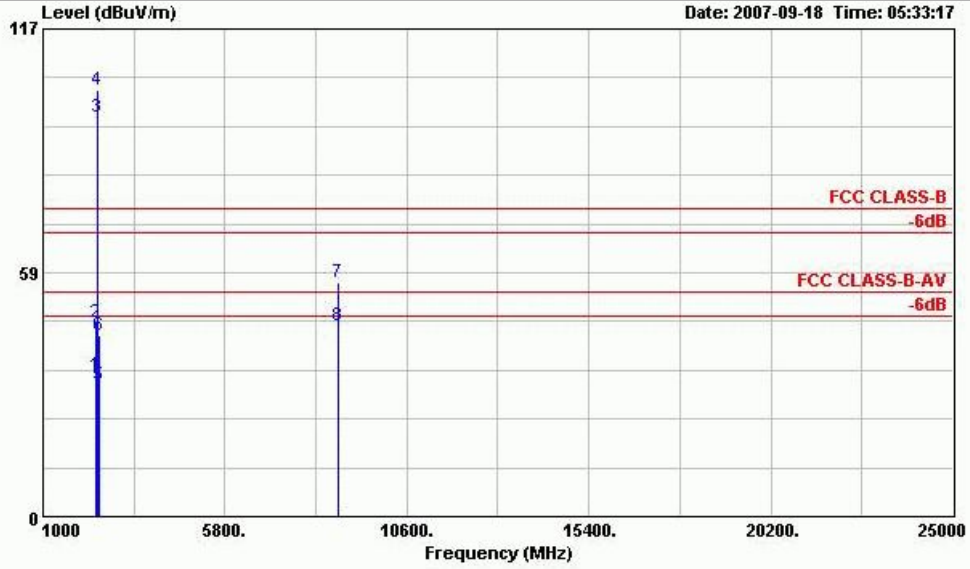

Site : 03CH04-HY
 Condition: FCC CLASS-B 3m HF-ANT-6903 HORIZONTAL
 EUT : AP
 POWER : 120Vac/60Hz
 MODEL : FR 791302
 HOME : 11b Tx_Ch06;2437MHz
 Data Rate: 5.5

	Freq	Level	Over	Limit	Read	Antenna	Cable	Preamp	Ant	Table	
	MHz	dBuV/m	Limit	Line	Level	Factor	Loss	Factor	Pos	Pos	Remark
			dB	dBuV/m	dBuV	dB/m	dB	dB	cm	deg	
1	2382.000	33.73	-20.27	54.00	35.73	28.03	3.74	33.78	100	87	Average
2	2382.000	46.50	-27.50	74.00	48.50	28.03	3.74	33.78	100	0	Peak
3 @	2437.000	95.69			97.50	28.19	3.79	33.79	100	87	Average
4 @	2437.000	102.26			104.07	28.19	3.79	33.79	100	0	Peak
5	2484.000	31.72	-22.28	54.00	33.42	28.26	3.84	33.80	100	87	Average
6	2484.000	43.57	-30.43	74.00	45.27	28.26	3.84	33.80	100	0	Peak
7	8781.000	56.04	-17.96	74.00	45.66	37.84	7.16	34.62	100	0	Peak
8	8781.000	45.76	-8.24	54.00	35.38	37.84	7.16	34.62	100	298	Average

Remark:

1. "3" represents the Fundamental Signal
2. "4" represents the Fundamental Signal



Polarization : Vertical (30MHz-1GHz)

The test that passed at minimum margin was marked by the boldface in the following table.

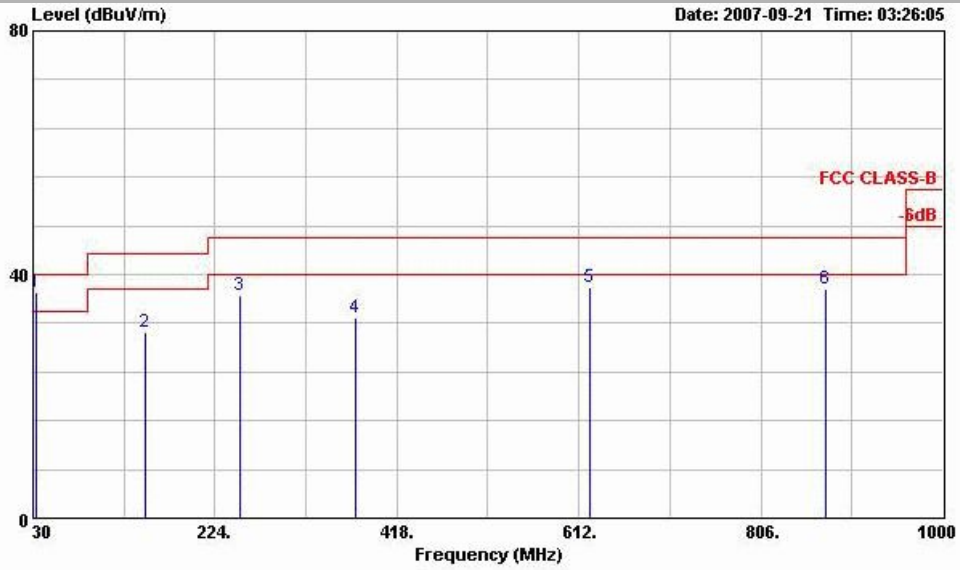

Site : 03CH04-HY
 Condition: FCC CLASS-B 3m ANT2724 VERTICAL
 EUT : AP
 POWER : 120Vac/60Hz
 MODEL : FR 791302
 MOME : 11b Tx_Ch06;2437MHz
 Data Rate: 5.5

	Freq	Level	Over	Limit	ReadAntenna	Cable	Preamp	Ant	Table		
	MHz	dBuV/m	dB	dBuV/m	Level	Loss	Factor	Pos	Pos	Remark	
					Factor	Factor		cm	deg		
1 !	32.700	37.16	-2.84	40.00	46.60	16.33	0.90	26.66	100	71 QP	
2	149.610	30.44	-13.06	43.50	44.31	10.75	1.66	26.28	---	---	Peak
3	250.050	36.46	-9.54	46.00	47.75	12.57	2.05	25.91	---	---	Peak
4	374.200	32.98	-13.02	46.00	41.85	14.88	2.49	26.24	---	---	Peak
5	624.100	37.78	-8.22	46.00	41.60	19.96	3.26	27.04	---	---	Peak
6	875.400	37.64	-8.36	46.00	37.77	22.62	3.92	26.67	---	---	Peak



Polarization : Vertical (1GHz-25GHz)

The test that passed at minimum margin was marked by the boldface in the following table.

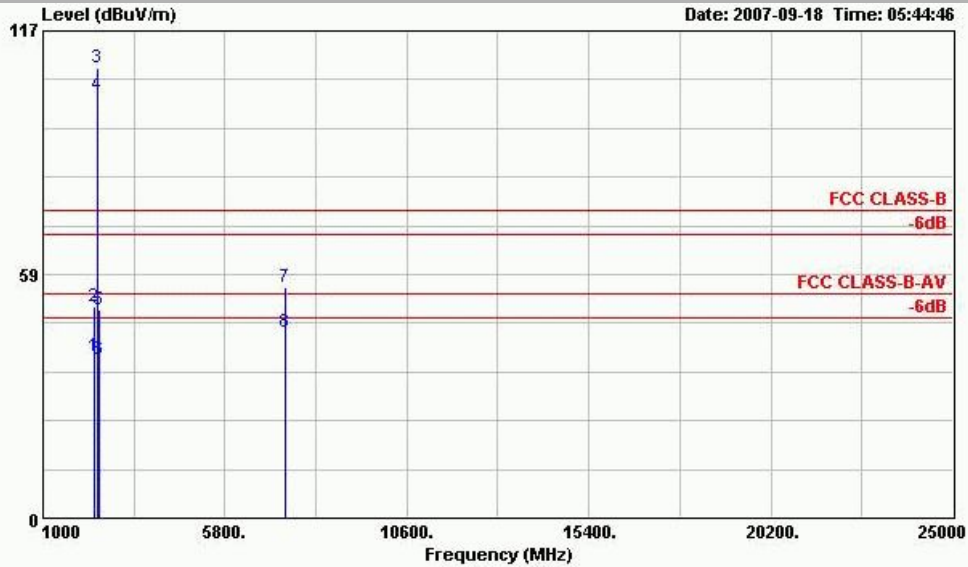

Site : 03CH04-HY
 Condition: FCC CLASS-B 3m HF-ANT-6903 VERTICAL
 EUT : AP
 POWER : 120Vac/60Hz
 MODEL : FR 791302
 MOME : 11b Tx_Ch06;2437MHz
 Data Rate: 5.5

	Freq	Level	Over	Limit	ReadAntenna	Cable	Preamp	Ant	Table	
	MHz	dBuV/m	dB	dBuV/m	dBuV	Loss	Factor	Pos	Pos	Remark
					dB/m	dB	dB	cm	deg	
1	2366.000	38.96	-15.04	54.00	41.03	28.00	3.71	33.78	100	112 Average
2	2366.000	50.75	-23.25	74.00	52.82	28.00	3.71	33.78	100	0 Peak
3 @	2437.000	108.04			109.85	28.19	3.79	33.79	100	0 Peak
4 @	2437.000	101.62			103.43	28.19	3.79	33.79	100	112 Average
5	2486.000	49.95	-24.05	74.00	51.65	28.26	3.84	33.80	100	0 Peak
6	2486.000	37.96	-16.04	54.00	39.66	28.26	3.84	33.80	100	112 Average
7	7401.000	55.23	-18.77	74.00	46.05	36.19	6.52	33.54	100	0 Peak
8	7401.000	44.64	-9.36	54.00	35.46	36.19	6.52	33.54	100	241 Average

Remark:

1. "3" represents the Fundamental Signal
2. "4" represents the Fundamental Signal



Test Mode : Mode 3
Polarization : Horizontal (30MHz-1GHz)

The test that passed at minimum margin was marked by the boldface in the following table.

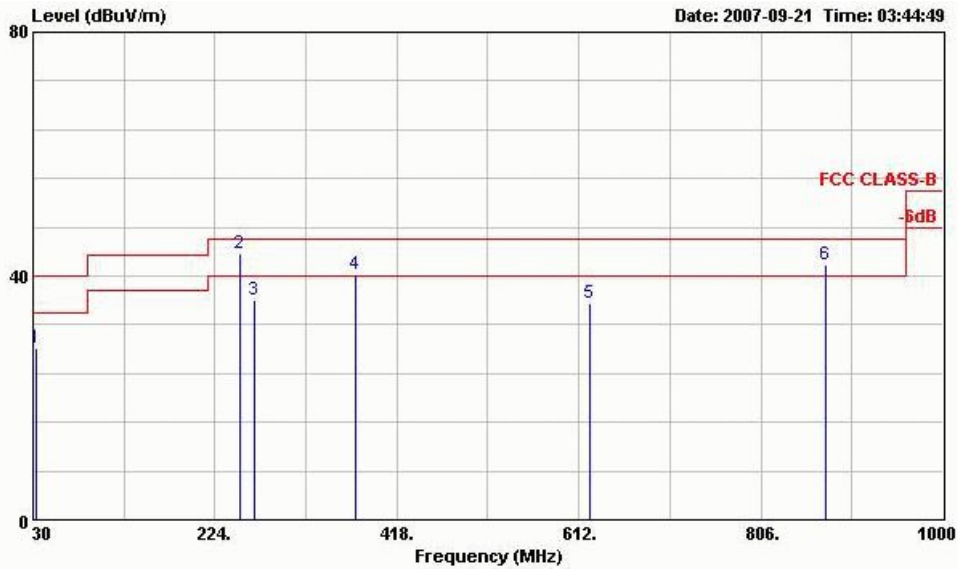

Site : 03CH04-HY
Condition: FCC CLASS-B 3m ANT2724 HORIZONTAL
EUT : AP
POWER : 120Vac/60Hz
MODEL : FR 791302
MOME : 11b Tx_Ch11;2462MHz
Data Rate: 5.5

	Freq	Level	Over	Limit	ReadAntenna	Cable	Preamp	Ant	Table	
	MHz	dBuV/m	dB	dBuV/m	Level	Loss	Factor	Pos	Pos	Remark
					dBuV	dB	dB	cm	deg	
1	32.700	28.14	-11.86	40.00	37.58	16.33	0.90	26.66	---	Peak
2 @	250.050	43.62	-2.38	46.00	54.91	12.57	2.05	25.91	100	254 QP
3	266.250	36.13	-9.87	46.00	47.39	12.48	2.11	25.85	---	Peak
4 !	374.200	40.25	-5.75	46.00	49.12	14.88	2.49	26.24	---	Peak
5	624.100	35.51	-10.49	46.00	39.33	19.96	3.26	27.04	---	Peak
6 !	875.400	41.82	-4.18	46.00	41.95	22.62	3.92	26.67	---	Peak



Polarization : Horizontal (1GHz-25GHz)

The test that passed at minimum margin was marked by the boldface in the following table.

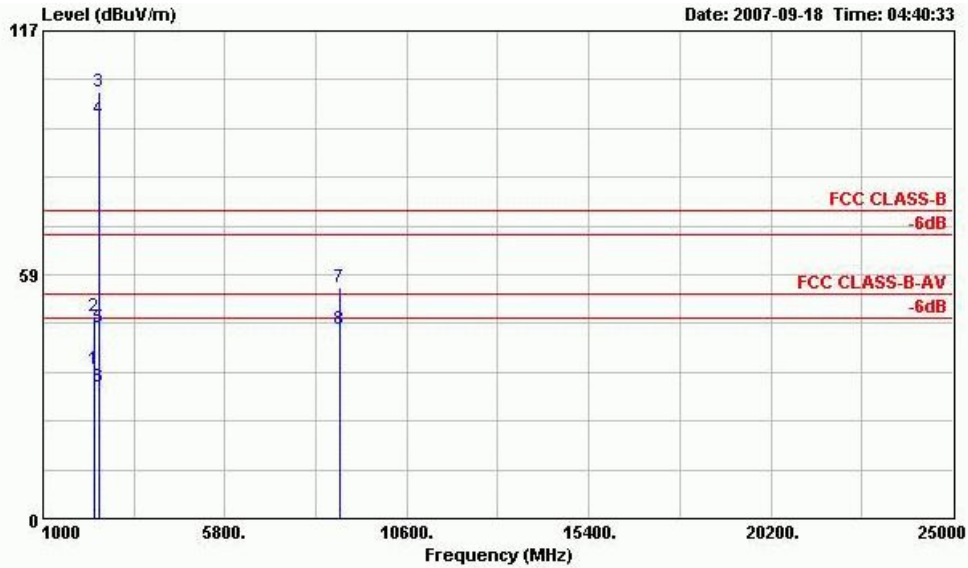

Site : 03CH04-HY
 Condition: FCC CLASS-B 3m HF-ANT-6903 HORIZONTAL
 EUT : AP
 POWER : 120Vac/60Hz
 MODEL : FR 791302
 MOME : 11b Tx_Ch11;2462MHz
 Data Rate: 5.5

	Freq	Level	Over	Limit	ReadAntenna	Cable	Preamp	Ant	Table	
	MHz	dBuV/m	Limit	Line	Level	Factor	Loss	Factor	Pos	Pos
			dB	dBuV/m	dBuV	dB/m	dB	dB	cm	deg
1	2356.000	35.61	-18.39	54.00	37.70	28.00	3.69	33.77	100	289 Average
2	2356.000	48.52	-25.48	74.00	50.61	28.00	3.69	33.77	100	0 Peak
3 @	2462.000	102.37			104.12	28.22	3.81	33.79	100	0 Peak
4 @	2462.000	95.82			97.57	28.22	3.81	33.79	100	289 Average
5	2488.220	45.76	-28.24	74.00	47.42	28.30	3.84	33.80	100	0 Peak
6	2488.220	31.71	-22.29	54.00	33.37	28.30	3.84	33.80	100	289 Average
7	8850.000	55.27	-18.73	74.00	44.83	37.92	7.20	34.68	100	0 Peak
8	8850.000	45.39	-8.61	54.00	34.95	37.92	7.20	34.68	100	286 Average

Remark:

1. "3" represents the Fundamental Signal
2. "4" represents the Fundamental Signal



Polarization : Vertical (30MHz-1GHz)

The test that passed at minimum margin was marked by the boldface in the following table.

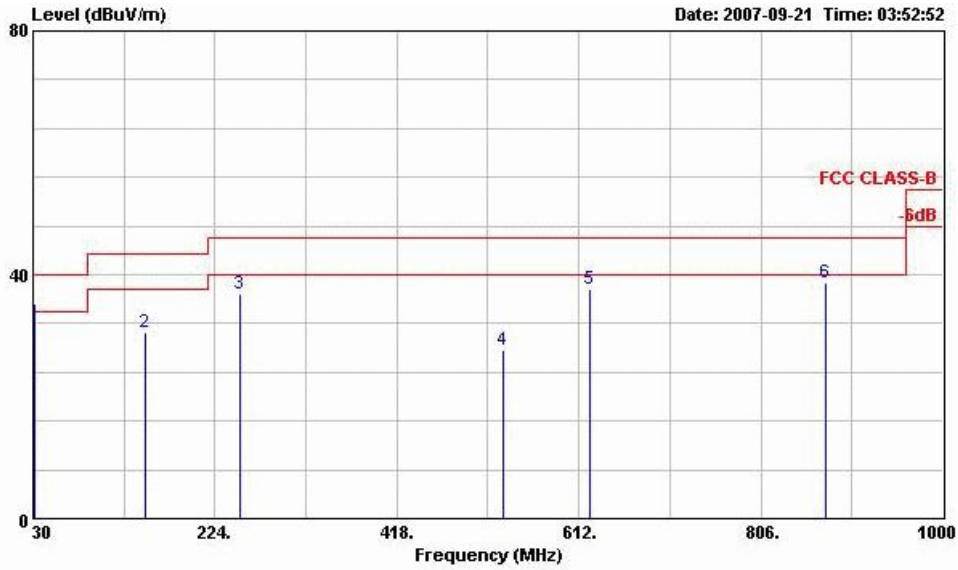

Site : 03CHO4-HY
 Condition: FCC CLASS-B 3m ANT2724 VERTICAL
 EUT : AP
 POWER : 120Vac/60Hz
 MODEL : FR 791302
 MOME : 11b Tx_Ch11;2462MHz
 Data Rate: 5.5

	Freq	Level	Over	Limit	ReadAntenna	Cable	Preamp	Ant	Table	
	MHz	dBuV/m	Limit	Line	Level	Loss	Factor	Pos	Pos	Remark
			dB	dBuV/m	dBuV	dB	dB	cm	deg	
1 !	31.890	35.22	-4.78	40.00	44.65	16.34	0.89	26.66	100	95 QP
2	150.420	30.55	-12.95	43.50	44.39	10.77	1.66	26.27	---	--- Peak
3	250.050	36.87	-9.13	46.00	48.16	12.57	2.05	25.91	---	--- Peak
4	531.700	27.68	-18.32	46.00	33.98	17.84	2.93	27.07	---	--- Peak
5	624.100	37.65	-8.35	46.00	41.47	19.96	3.26	27.04	---	--- Peak
6	875.400	38.78	-7.22	46.00	38.91	22.62	3.92	26.67	---	--- Peak



Polarization : Vertical (1GHz-25GHz)

The test that passed at minimum margin was marked by the boldface in the following table.

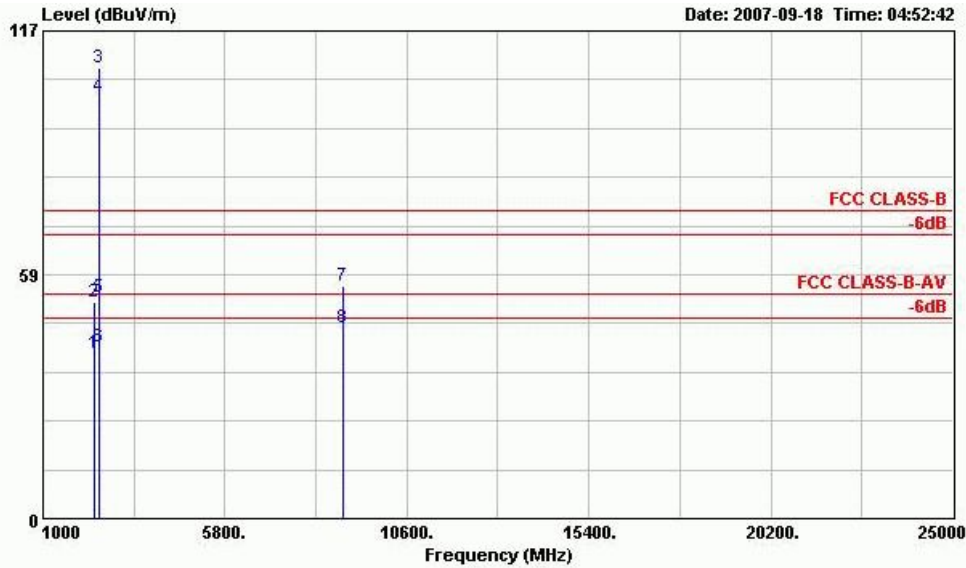

Site : 03CH04-HY
 Condition: FCC CLASS-B 3m HF-ANT-6903 VERTICAL
 EUT : AP
 POWER : 120Vac/60Hz
 MODEL : FR 791302
 MOME : 11b Tx_Ch11;2462MHz
 Data Rate: 5.5

	Freq	Level	Over	Limit	ReadAntenna	Cable	Preamp	Ant	Table	
	MHz	dBuV/m	dB	dBuV/m	dBuV	dB/m	dB	dB	cm	deg
1	2342.000	39.61	-14.39	54.00	41.73	27.96	3.69	33.77	100	113 Average
2	2342.000	51.94	-22.06	74.00	54.06	27.96	3.69	33.77	100	0 Peak
3 @	2462.000	108.19			109.94	28.22	3.81	33.79	100	0 Peak
4 @	2462.000	101.37			103.12	28.22	3.81	33.79	100	113 Average
5	2485.180	53.27	-20.73	74.00	54.97	28.26	3.84	33.80	100	0 Peak
6	2485.180	41.18	-12.82	54.00	42.88	28.26	3.84	33.80	100	113 Average
7	8934.000	55.64	-18.36	74.00	45.11	38.02	7.25	34.74	100	0 Peak
8	8934.000	45.87	-8.13	54.00	35.34	38.02	7.25	34.74	100	15 Average

Remark:

1. "3" represents the Fundamental Signal
2. "4" represents the Fundamental Signal



Test Mode : Mode 4
Polarization : Horizontal (30MHz-1GHz)

The test that passed at minimum margin was marked by the boldface in the following table.

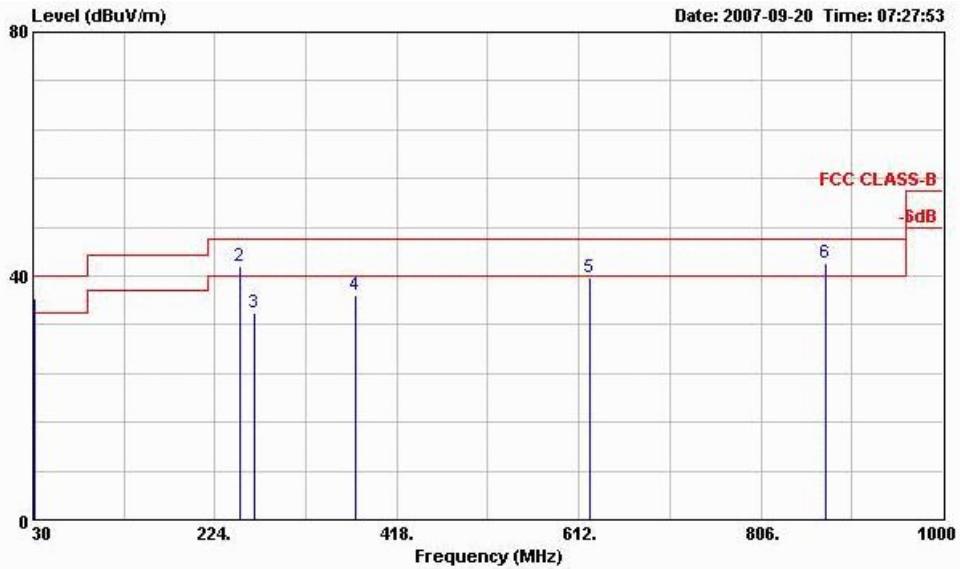

Site : 03CH04-HY
Condition: FCC CLASS-B 3m ANT2724 HORIZONTAL
EUT : AP
POWER : 120Vac/60Hz
MODEL : FR 791302
MOME : 11g Tx_Ch01;2412MHz
Data Rate: 54

	Freq	Level	Over	Limit	ReadAntenna	Cable	Preamp	Ant	Table		
	MHz	dBuV/m	dB	dBuV/m	Level	Loss	Factor	Pos	Pos	Remark	
					dBuV	dB	dB	cm	deg		
1 !	31.890	36.29	-3.71	40.00	45.72	16.34	0.89	26.66	100	251 Peak	
2 !	250.050	41.64	-4.36	46.00	52.93	12.57	2.05	25.91	---	---	Peak
3	266.250	33.92	-12.08	46.00	45.18	12.48	2.11	25.85	---	---	Peak
4	374.200	36.85	-9.15	46.00	45.72	14.88	2.49	26.24	---	---	Peak
5	624.100	39.67	-6.33	46.00	43.49	19.96	3.26	27.04	---	---	Peak
6 !	875.400	42.09	-3.91	46.00	42.22	22.62	3.92	26.67	---	---	Peak



Polarization : Horizontal (1GHz-25GHz)

The test that passed at minimum margin was marked by the boldface in the following table.

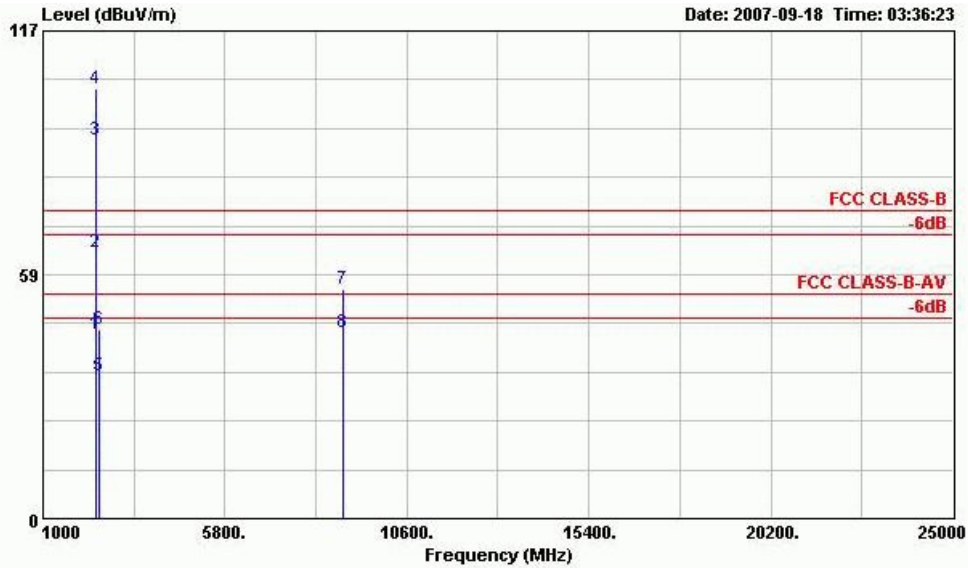

Site : 03CH04-HY
 Condition: FCC CLASS-B 3m HF-ANT-6903 HORIZONTAL
 EUT : AP
 POWER : 120Vac/60Hz
 MODEL : FR 791302
 MOME : 11g Tx_Ch01;2412MHz
 Data Rate: 54

	Freq	Level	Over	Limit	ReadAntenna	Cable	Preamp	Ant	Table	
	MHz	dBuV/m	Limit	Line	Level	Factor	Loss	Factor	Pos	Pos
			dB	dBuV/m	dBuV	dB/m	dB	dB	cm	deg
1	2389.610	44.28	-9.72	54.00	46.24	28.07	3.74	33.78	100	242 Average
2	2389.610	63.90	-10.10	74.00	65.86	28.07	3.74	33.78	100	0 Peak
3 @	2412.000	90.81			92.72	28.11	3.76	33.78	100	242 Average
4 @	2412.000	103.19			105.10	28.11	3.76	33.78	100	0 Peak
5	2486.000	34.11	-19.89	54.00	35.81	28.26	3.84	33.80	100	242 Average
6	2486.000	45.43	-28.57	74.00	47.13	28.26	3.84	33.80	100	0 Peak
7	8922.000	55.18	-18.82	74.00	44.69	38.00	7.23	34.74	100	0 Peak
8	8922.000	44.73	-9.27	54.00	34.24	38.00	7.23	34.74	100	110 Average

Remark:

1. "3" represents the Fundamental Signal
2. "4" represents the Fundamental Signal



Polarization : Vertical (30MHz-1GHz)

The test that passed at minimum margin was marked by the boldface in the following table.

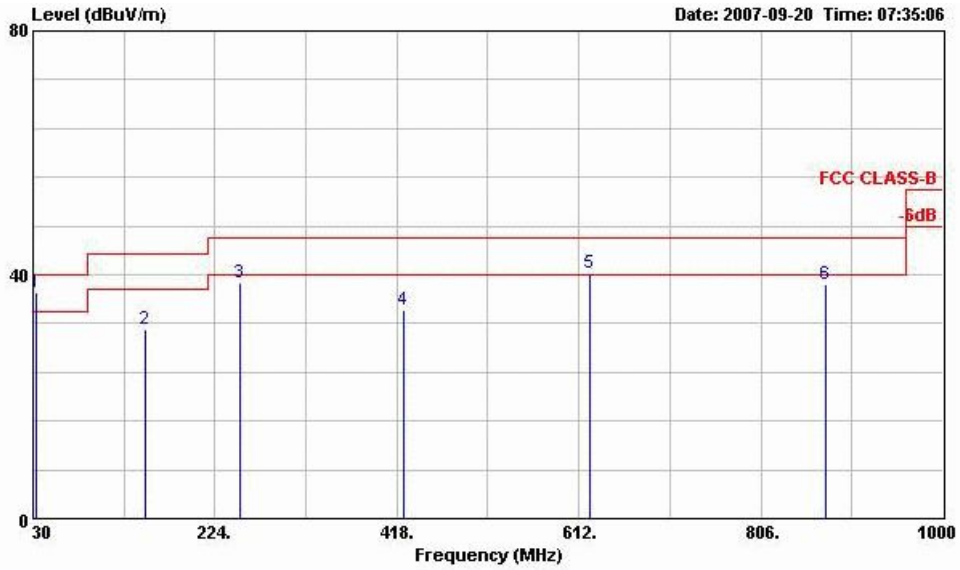

Site : 03CH04-HY
 Condition: FCC CLASS-B 3m ANT2724 VERTICAL
 EUT : AP
 POWER : 120Vac/60Hz
 MODEL : FR 791302
 MOME : 11g Tx_Ch01;2412MHz
 Data Rate: 54

	Freq	Level	Over	Limit	ReadAntenna	Cable	Preamp	Ant	Table	
	MHz	dBuV/m	Limit	Line	Level	Factor	Loss	Pos	Pos	Remark
			dB	dBuV/m	dBuV	dB/m	dB	dB	cm	deg
1	32.700	36.99	-3.01	40.00	46.43	16.33	0.90	26.66	100	107 QP
2	149.340	30.96	-12.54	43.50	44.83	10.75	1.66	26.28	---	Peak
3	250.050	38.77	-7.23	46.00	50.06	12.57	2.05	25.91	---	Peak
4	424.600	34.21	-11.79	46.00	42.09	16.04	2.65	26.57	---	Peak
5	624.100	40.24	-5.76	46.00	44.06	19.96	3.26	27.04	---	Peak
6	875.400	38.50	-7.50	46.00	38.63	22.62	3.92	26.67	100	203 QP



Polarization : Vertical (1GHz-25GHz)

The test that passed at minimum margin was marked by the boldface in the following table.

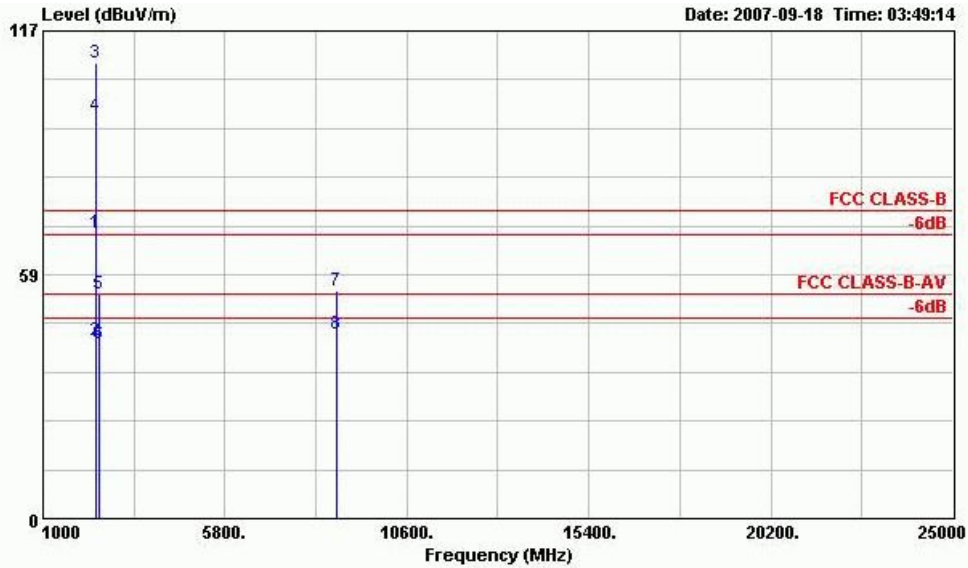

Site : 03CH04-HY
 Condition: FCC CLASS-B 3m HF-ANT-6903 VERTICAL
 EUT : AP
 POWER : 120Vac/60Hz
 MODEL : FR 791302
 MOME : 11g Tx_Ch01;2412MHz
 Data Rate: 54

	Freq	Level	Over	Limit	ReadAntenna	Cable	Preamp	Ant	Table	
	MHz	dBuV/m	Limit	Line	Level	Factor	Loss	Factor	Pos	Pos
			dB	dBuV/m	dBuV	dB/m	dB	dB	cm	deg
1 !	2387.330	68.54	-5.46	74.00	70.50	28.07	3.74	33.78	100	0 Peak
2	2387.330	42.86	-11.14	54.00	44.82	28.07	3.74	33.78	100	112 Average
3 @	2412.000	109.14			111.05	28.11	3.76	33.78	100	0 Peak
4 @	2412.000	96.54			98.50	28.07	3.74	33.78	100	112 Average
5	2486.000	53.85	-20.15	74.00	55.55	28.26	3.84	33.80	100	0 Peak
6	2486.000	41.89	-12.11	54.00	43.59	28.26	3.84	33.80	100	112 Average
7	8733.000	54.79	-19.21	74.00	44.46	37.78	7.13	34.58	100	0 Peak
8	8733.000	44.14	-9.86	54.00	33.81	37.78	7.13	34.58	100	245 Average

Remark:

1. "3" represents the Fundamental Signal
2. "4" represents the Fundamental Signal



Test Mode : Mode 5
 Polarization : Horizontal (30MHz-1GHz)

The test that passed at minimum margin was marked by the boldface in the following table.

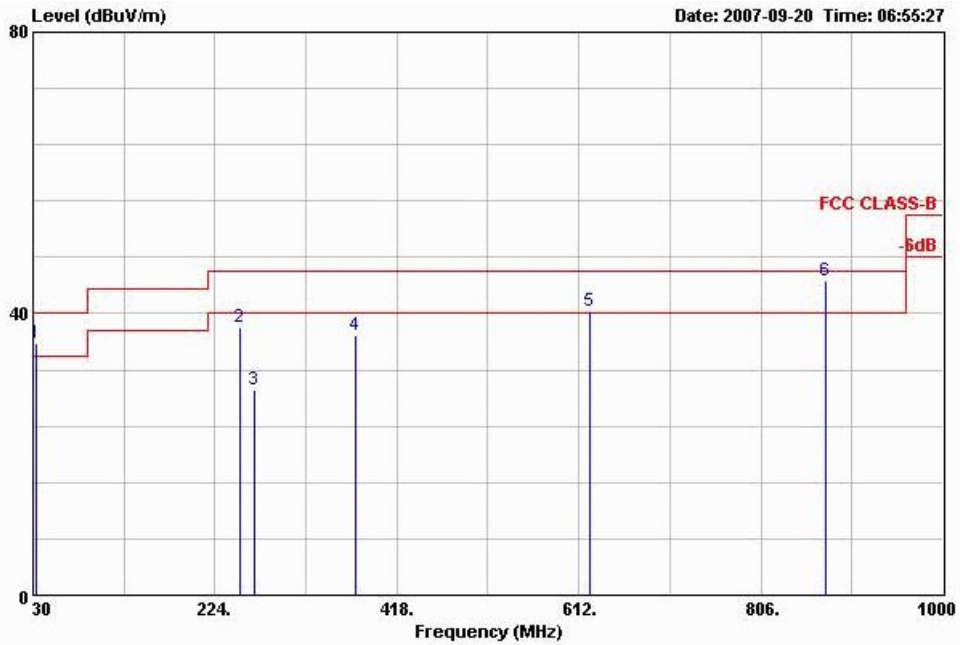

Site : 03CH04-HY
 Condition: FCC CLASS-B 3m ANT2724 HORIZONTAL
 EUT : AP
 POWER : 120Vac/60Hz
 MODEL : FR 791302
 MOME : 11g Tx_Ch06;2437MHz
 Data Rate: 54

	Freq	Level	Over Limit	Limit Line	ReadAntenna Level	Antenna Factor	Cable Loss	Preamp Factor	Ant Pos	Table Pos	Remark
	MHz	dBuV/m	dB	dBuV/m	dBuV	dB/m	dB	dB	cm	deg	
1 !	32.700	35.87	-4.13	40.00	45.31	16.33	0.90	26.66	---	---	Peak
2	250.050	37.99	-8.01	46.00	49.28	12.57	2.05	25.91	---	---	Peak
3	266.250	29.22	-16.78	46.00	40.48	12.48	2.11	25.85	---	---	Peak
4	374.200	36.95	-9.05	46.00	45.82	14.88	2.49	26.24	---	---	Peak
5 !	624.100	40.35	-5.65	46.00	44.17	19.96	3.26	27.04	---	---	Peak
6 !	875.400	44.69	-1.31	46.00	44.82	22.62	3.92	26.67	100	273	QP



Polarization : Horizontal (1GHz-25GHz)

The test that passed at minimum margin was marked by the boldface in the following table.

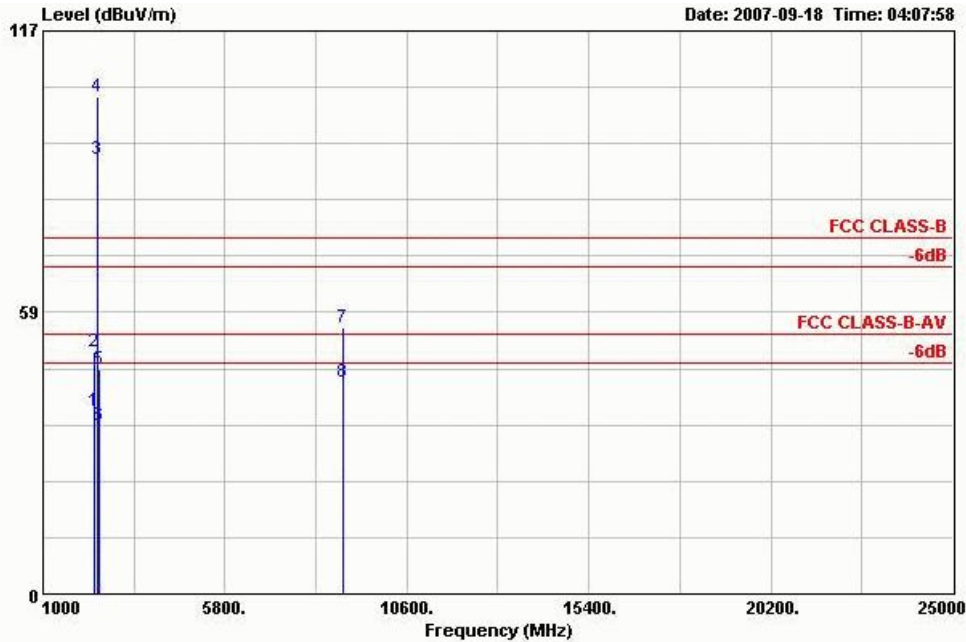

Site : 03CH04-HY
 Condition: FCC CLASS-B 3m HF-ANT-6903 HORIZONTAL
 EUT : AP
 POWER : 120Vac/60Hz
 MODEL : FR 791302
 MOME : 11g Tx_Ch06;2437MHz
 Data Rate: 54

	Freq	Level	Over	Limit	ReadAntenna	Cable	Preamp	Ant	Table	
	MHz	dBuV/m	dB	dBuV/m	Level	Loss	Factor	Pos	Pos	Remark
					dBuV	dB/m	dB	dB	cm	deg
1	2374.000	38.13	-15.87	54.00	40.16	28.03	3.71	33.78	100	88 Average
2	2374.000	50.37	-23.63	74.00	52.40	28.03	3.71	33.78	100	0 Peak
3 X	2437.000	90.50			92.31	28.19	3.79	33.79	100	88 Average
4 X	2437.000	103.48			105.29	28.19	3.79	33.79	100	0 Peak
5	2484.000	46.57	-27.43	74.00	48.27	28.26	3.84	33.80	100	0 Peak
6	2484.000	35.13	-18.87	54.00	36.83	28.26	3.84	33.80	100	88 Average
7	8934.000	55.36	-18.64	74.00	44.83	38.02	7.25	34.74	100	0 Peak
8	8934.000	44.10	-9.90	54.00	33.57	38.02	7.25	34.74	100	16 Average

Remark:

1. "3" represents the Fundamental Signal
2. "4" represents the Fundamental Signal



Polarization : Vertical (30MHz-1GHz)

The test that passed at minimum margin was marked by the boldface in the following table.

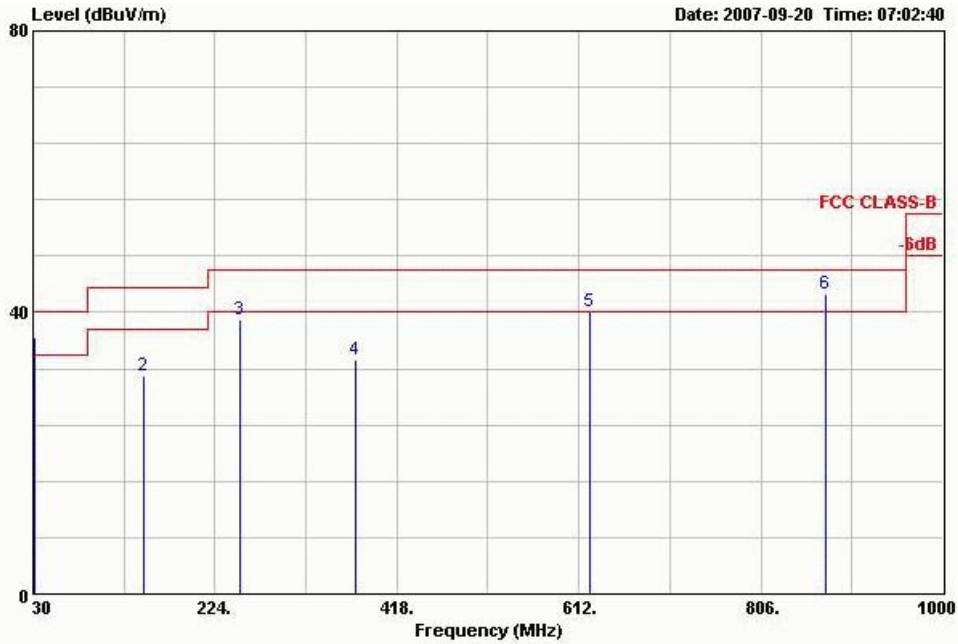

Site : 03CH04-HY
 Condition: FCC CLASS-B 3m ANT2724 VERTICAL
 EUT : AP
 POWER : 120Vac/60Hz
 MODEL : FR 791302
 MOME : 11g Tx_Ch06;2437MHz
 Data Rate: 54

	Freq	Level	Over	Limit	ReadAntenna	Cable	Preamp	Ant	Table	
	MHz	dBuV/m	Limit	Line	Level	Factor	Loss	Factor	Pos	Pos
			dB	dBuV/m	dBuV	dB/m	dB	dB	cm	deg
1 !	31.890	36.49	-3.51	40.00	45.92	16.34	0.89	26.66	100	303 QP
2	148.530	31.06	-12.44	43.50	44.95	10.74	1.66	26.28	---	---
3	250.050	39.04	-6.96	46.00	50.33	12.57	2.05	25.91	---	---
4	374.200	33.37	-12.63	46.00	42.24	14.88	2.49	26.24	---	---
5 !	624.100	40.14	-5.86	46.00	43.96	19.96	3.26	27.04	---	---
6 !	875.400	42.62	-3.38	46.00	42.75	22.62	3.92	26.67	100	241 Peak



Polarization : Vertical (1GHz-25GHz)

The test that passed at minimum margin was marked by the boldface in the following table.

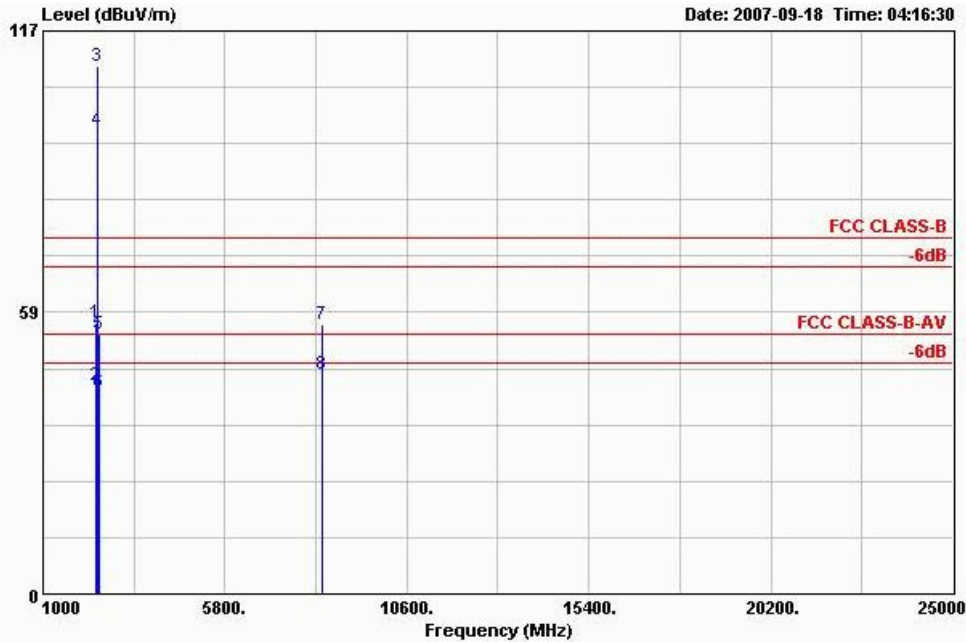

Site : 03CH04-HY
 Condition: FCC CLASS-B 3m HF-ANT-6903 VERTICAL
 EUT : AP
 POWER : 120Vac/60Hz
 MODEL : FR 791302
 MOME : 11g Tx_Ch06;2437MHz
 Data Rate: 54

	Freq	Level	Over	Limit	Read	Antenna	Cable	Preamp	Ant	Table	
	MHz	dBuV/m	dB	dBuV/m	Level	Factor	Loss	Factor	Pos	Pos	Remark
					dBuV	dB/m	dB	dB	cm	deg	
1	2382.000	56.25	-17.75	74.00	58.25	28.03	3.74	33.78	100	0	Peak
2	2382.000	43.49	-10.51	54.00	45.49	28.03	3.74	33.78	100	111	Average
3 X	2437.000	109.69			111.51	28.19	3.79	33.79	100	0	Peak
4 @	2437.000	96.50			98.31	28.19	3.79	33.79	100	111	Average
5	2484.000	53.94	-20.06	74.00	55.64	28.26	3.84	33.80	100	0	Peak
6	2484.000	42.02	-11.98	54.00	43.72	28.26	3.84	33.80	100	111	Average
7	8361.000	56.03	-17.97	74.00	45.97	37.31	6.95	34.19	100	0	Peak
8	8361.000	45.63	-8.37	54.00	35.57	37.31	6.95	34.19	100	206	Average

Remark:

1. "3" represents the Fundamental Signal
2. "4" represents the Fundamental Signal



Test Mode : Mode 6
 Polarization : Horizontal (30MHz-1GHz)

The test that passed at minimum margin was marked by the boldface in the following table.

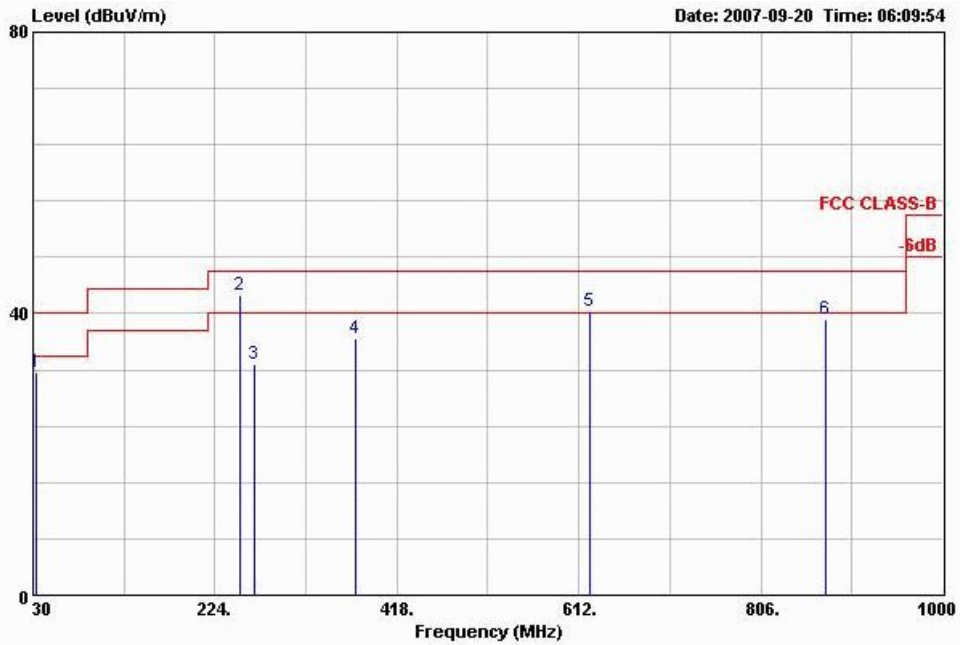

Site : 03CH04-HY
 Condition: FCC CLASS-B 3m ANT2724 HORIZONTAL
 EUT : AP
 POWER : 120Vac/60Hz
 MODEL : FR 791302
 MOME : 11g Tx_Ch11;2462MHz
 Data Rate: 54

	Freq	Level	Over Limit	Limit Line	ReadAntenna Level	Antenna Factor	Cable Loss	Preamp Factor	Ant Pos	Table Pos	Remark
	MHz	dBuV/m	dB	dBuV/m	dBuV	dB/m	dB	dB	cm	deg	
1	32.700	31.77	-8.23	40.00	41.21	16.33	0.90	26.66	---	---	Peak
2 !	250.050	42.53	-3.47	46.00	53.82	12.57	2.05	25.91	100	134	Peak
3	266.250	32.81	-13.19	46.00	44.07	12.48	2.11	25.85	---	---	Peak
4	374.200	36.45	-9.55	46.00	45.32	14.88	2.49	26.24	---	---	Peak
5 !	624.100	40.41	-5.59	46.00	44.23	19.96	3.26	27.04	---	---	Peak
6	875.400	39.23	-6.77	46.00	39.36	22.62	3.92	26.67	100	203	QP



Polarization : Horizontal (1GHz-25GHz)

The test that passed at minimum margin was marked by the boldface in the following table.

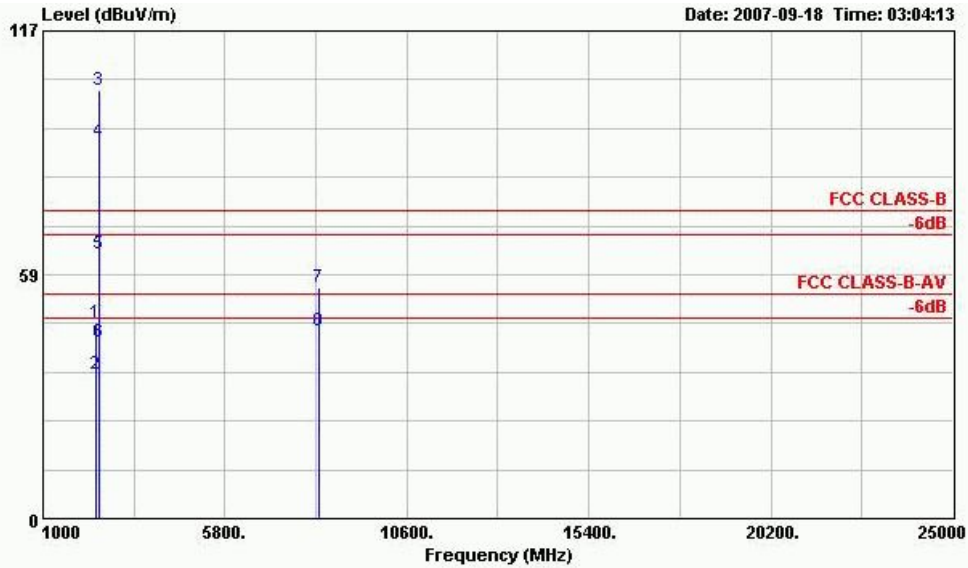

Site : 03CH04-HY
 Condition: FCC CLASS-B 3m HF-ANT-6903 HORIZONTAL
 EUT : AP
 POWER : 120Vac/60Hz
 MODEL : FR 791302
 MOME : 11g Tx_Ch11;2462MHz
 Data Rate: 54

	Freq	Level	Over	Limit	ReadAntenna	Cable	Preamp	Ant	Table	
	MHz	dBuV/m	Limit	Line	Level	Factor	Loss	Factor	Pos	Pos
			dB	dBuV/m	dBuV	dB/m	dB	dB	cm	deg
1	2382.000	47.14	-26.86	74.00	49.14	28.03	3.74	33.78	100	0 Peak
2	2382.000	34.82	-19.18	54.00	36.82	28.03	3.74	33.78	100	115 Average
3 X	2462.000	102.70			104.45	28.22	3.81	33.79	100	0 Peak
4 @	2462.000	90.35			92.10	28.22	3.81	33.79	100	115 Average
5	2483.850	63.46	-10.54	74.00	65.16	28.26	3.84	33.80	100	0 Peak
6	2483.850	42.17	-11.83	54.00	43.87	28.26	3.84	33.80	100	115 Average
7	8289.000	55.43	-18.57	74.00	45.37	37.21	6.91	34.06	100	0 Peak
8	8289.000	45.16	-8.84	54.00	35.10	37.21	6.91	34.06	100	11 Average

Remark:

1. "3" represents the Fundamental Signal
2. "4" represents the Fundamental Signal



Polarization : Vertical (30MHz-1GHz)

The test that passed at minimum margin was marked by the boldface in the following table.

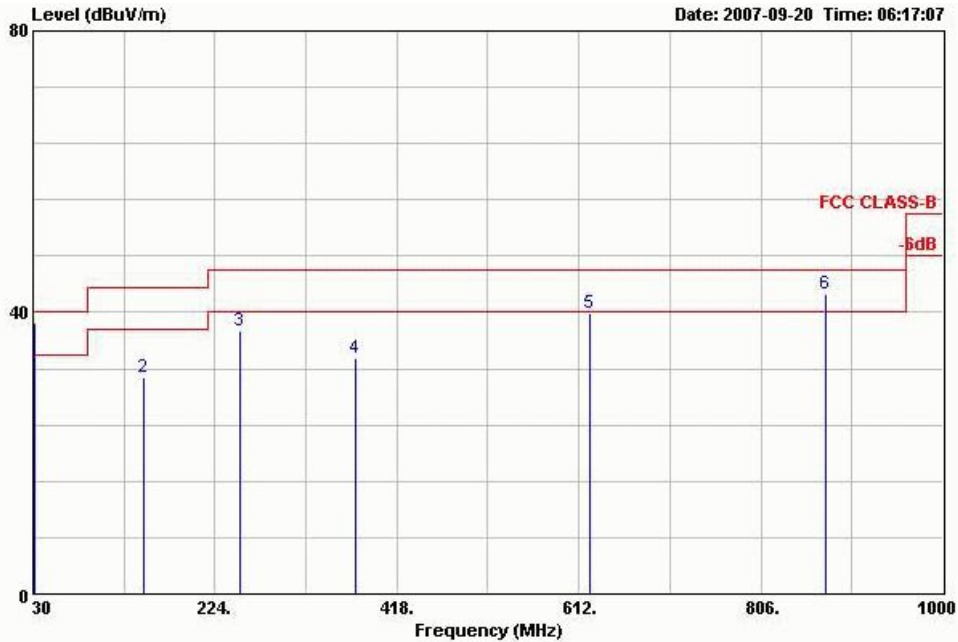

Site : 03CH04-HY
 Condition: FCC CLASS-B 3m ANT2724 VERTICAL
 EUT : AP
 POWER : 120Vac/60Hz
 MODEL : FR 791302
 MOME : 11g Tx_Ch11;2462MHz
 Data Rate: 54

	Freq	Level	Over	Limit	Read	Antenna	Cable	Preamp	Ant	Table	
	MHz	dBuV/m	Limit	Line	Level	Factor	Loss	Factor	Pos	Pos	Remark
			dB	dBuV/m	dBuV	dB/m	dB	dB	cm	deg	
1	31.890	38.51	-1.49	40.00	47.94	16.34	0.89	26.66	100	235	QP
2	147.450	30.88	-12.62	43.50	44.80	10.72	1.65	26.28	---	---	Peak
3	250.050	37.44	-8.56	46.00	48.73	12.57	2.05	25.91	---	---	Peak
4	374.200	33.58	-12.42	46.00	42.45	14.88	2.49	26.24	---	---	Peak
5	624.100	39.78	-6.22	46.00	43.60	19.96	3.26	27.04	---	---	Peak
6	875.400	42.66	-3.34	46.00	42.79	22.62	3.92	26.67	---	---	Peak



Polarization : Vertical (1GHz-25GHz)

The test that passed at minimum margin was marked by the boldface in the following table.

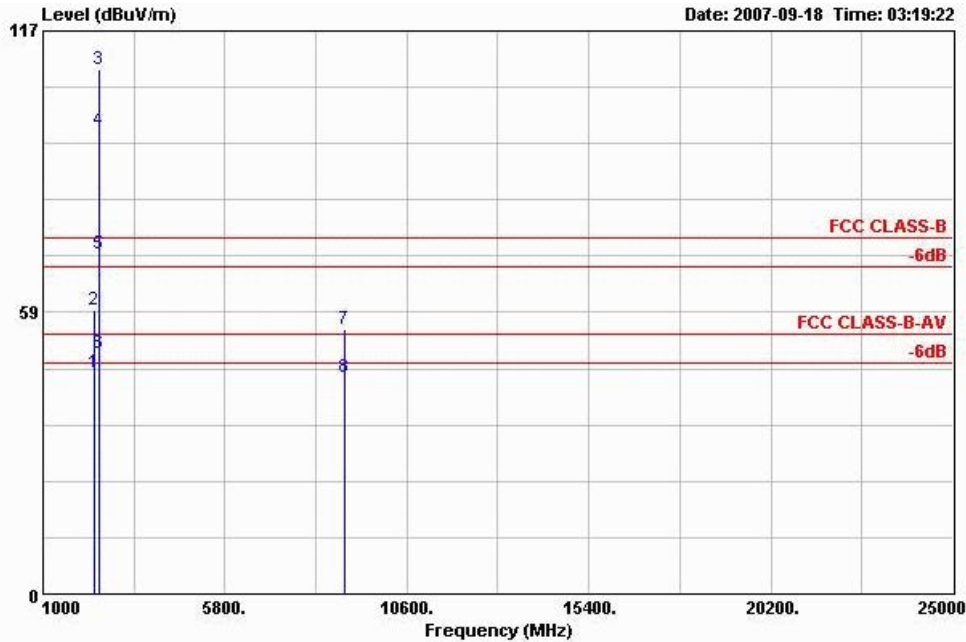

Site :03CH04-HY
 Condition:FCC CLASS-B 3m HF-ANT-6903 VERTICAL
 EUT :AP
 POWER :120Vac/60Hz
 MODEL :FR 791302
 MOME :11g Tx_Ch11;2462MHz
 Data Rate:54

	Freq	Level	Over	Limit	Read	Antenna	Cable	Preamp	Ant	Table	
	MHz	dBuV/m	dB	dBuV/m	Level	Factor	Loss	Factor	Pos	Pos	Remark
					dBuV	dB/m	dB	dB	cm	deg	
1	2340.000	45.96	-8.04	54.00	48.08	27.96	3.69	33.77	100	113	Average
2	2340.000	59.09	-14.91	74.00	61.21	27.96	3.69	33.77	100	0	Peak
3 X	2462.000	109.05			110.80	28.22	3.81	33.79	100	0	Peak
4 @	2462.000	96.26			98.01	28.22	3.81	33.79	100	113	Average
5 !	2483.850	70.60	-3.40	74.00	72.30	28.26	3.84	33.80	100	0	Peak
6 !	2483.850	50.15	-3.85	54.00	51.85	28.26	3.84	33.80	100	113	Average
7	8946.000	55.03	-18.97	74.00	44.52	38.02	7.25	34.76	100	0	Peak
8	8946.000	44.98	-9.02	54.00	34.47	38.02	7.25	34.76	100	269	Average

Remark:

1. "3" represents the Fundamental Signal
2. "4" represents the Fundamental Signal



Test Mode : Mode 7
Polarization : Horizontal (30MHz-1GHz)

The test that passed at minimum margin was marked by the boldface in the following table.

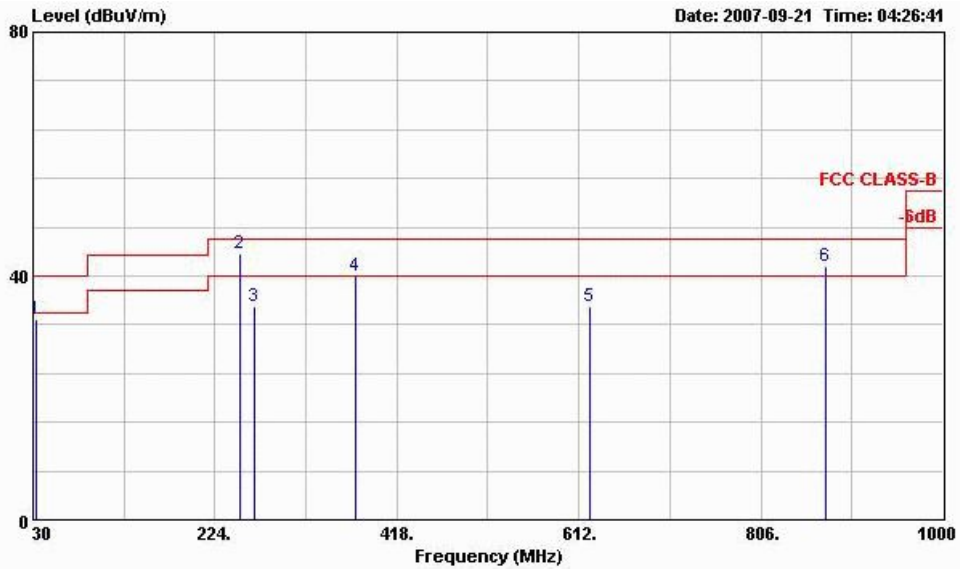

Site : 03CH04-HY
Condition: FCC CLASS-B 3m ANT2724 HORIZONTAL
EUT : AP
POWER : 120Vac/60Hz
MODEL : FR 791302
MOME : 11a Tx_Ch149;5745MHz
Data Rate: 54

	Freq	Level	Over	Limit	ReadAntenna	Cable	Preamp	Ant	Table		
	MHz	dBuV/m	Limit	Line	Level	Loss	Factor	Pos	Pos	Remark	
			dB	dBuV/m	dBuV	dB	dB	cm	deg		
1	32.700	32.85	-7.15	40.00	42.29	16.33	0.90	26.66	---	---	Peak
2 !	250.500	43.78	-2.22	46.00	55.07	12.57	2.05	25.91	100	260	QP
3	266.250	35.11	-10.89	46.00	46.37	12.48	2.11	25.85	---	---	Peak
4 !	374.200	40.00	-6.00	46.00	48.87	14.88	2.49	26.24	---	---	Peak
5	624.100	35.01	-10.99	46.00	38.83	19.96	3.26	27.04	---	---	Peak
6 !	875.400	41.51	-4.49	46.00	41.64	22.62	3.92	26.67	---	---	Peak



Polarization : Horizontal (1GHz-25GHz)

■ The test that passed at minimum margin was marked by the boldface in the following table.

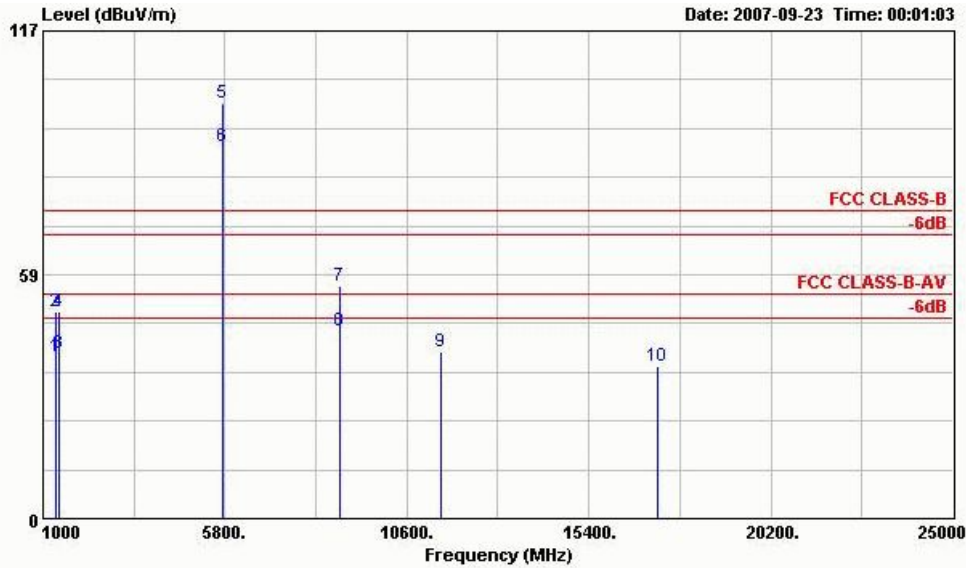

Site : 03CHO4-HY
 Condition: FCC CLASS-B 3m HF-ANT-6903 HORIZONTAL
 EUT : AP
 POWER : 120Vac/60Hz
 MODEL : FR 791302
 MOME : 11a Tx_Ch149;5745MHz
 Data Rate: 54

	Freq	Level	Over	Limit	ReadAntenna	Cable	Preamp	Ant	Table	
	MHz	dBuV/m	Limit	Line	Level	Factor	Loss	Pos	Pos	Remark
			dB	dBuV/m	dBuV	dB/m	dB	dB	cm	deg
1	1332.000	38.71	-15.29	54.00	45.16	24.90	2.60	33.95	100	331 Average
2	1332.000	49.65	-24.35	74.00	56.10	24.90	2.60	33.95	100	0 Peak
3	1412.000	39.77	-14.23	54.00	45.85	25.08	2.68	33.84	100	241 Average
4	1412.000	49.77	-24.23	74.00	55.85	25.08	2.68	33.84	100	0 Peak
5 X	5745.000	99.62			93.70	33.94	6.02	34.05	100	0 Peak
6 X	5745.000	89.39			83.47	33.94	6.02	34.05	100	269 Average
7	8822.000	55.62	-18.38	74.00	45.22	37.88	7.18	34.66	100	0 Peak
8	8822.000	45.21	-8.79	54.00	34.81	37.88	7.18	34.66	100	25 Average
9	11481.000	40.19	-33.81	74.00	78.30	-11.66	7.84	34.30	100	0 Peak
10	17229.000	36.40	-37.60	74.00	71.85	-11.07	9.42	33.81	100	0 Peak

Remark:

1. "5" represents the Fundamental Signal
2. "6" represents the Fundamental Signal



Polarization : Vertical (30MHz-1GHz)

The test that passed at minimum margin was marked by the boldface in the following table.

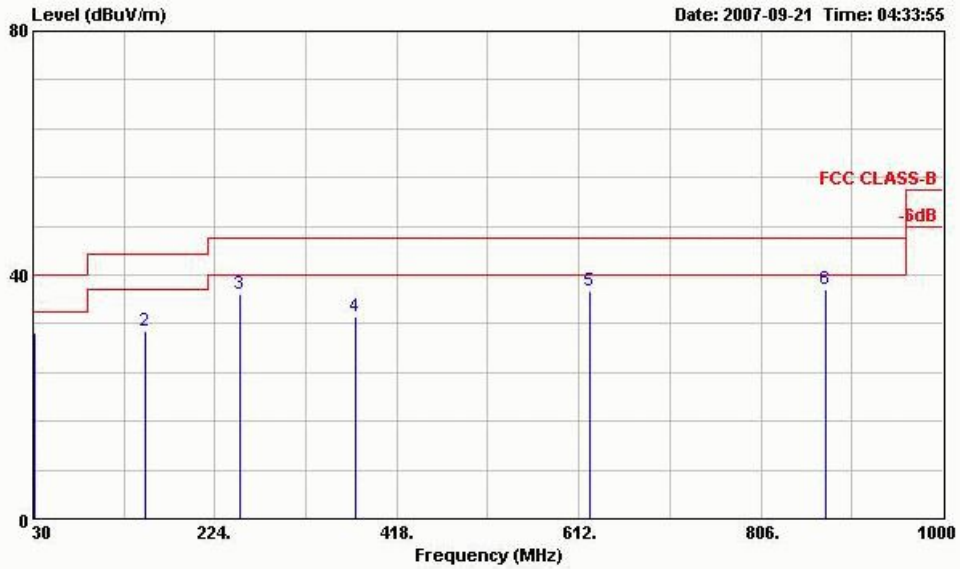

Site : 03CH04-HY
 Condition: FCC CLASS-B 3m ANT2724 VERTICAL
 EUT : AP
 POWER : 120Vac/60Hz
 MODEL : FR 791302
 MOME : 11a Tx_Ch149;5745MHz
 Data Rate: 54

	Freq	Level	Over Limit	Limit Line	ReadAntenna Level	Antenna Factor	Cable Loss	Preamp Factor	Ant Pos	Table Pos	Remark
	MHz	dBuV/m	dB	dBuV/m	dBuV	dB/m	dB	dB	cm	deg	
1	31.890	30.60	-9.40	40.00	40.03	16.34	0.89	26.66	---	---	Peak
2	149.610	30.84	-12.66	43.50	44.71	10.75	1.66	26.28	---	---	Peak
3	250.050	36.85	-9.15	46.00	48.14	12.57	2.05	25.91	---	---	Peak
4	374.200	33.27	-12.73	46.00	42.14	14.88	2.49	26.24	---	---	Peak
5	624.100	37.34	-8.66	46.00	41.16	19.96	3.26	27.04	---	---	Peak
6 @	875.400	37.54	-8.46	46.00	37.67	22.62	3.92	26.67	100	35	Peak



Polarization : Vertical (1GHz-25GHz)

The test that passed at minimum margin was marked by the boldface in the following table.

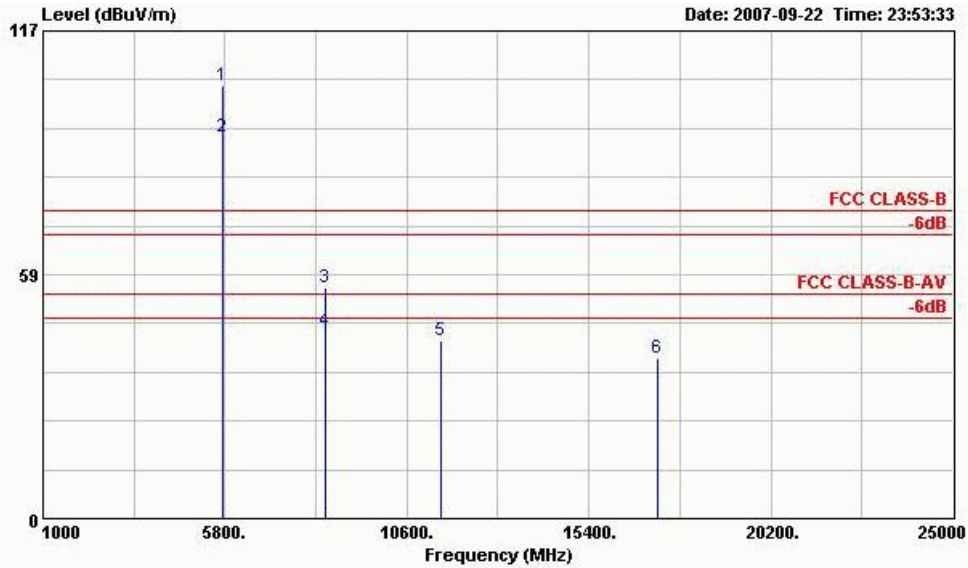

Site : 03CHO4-HY
 Condition: FCC CLASS-B 3m HF-ANT-6903 VERTICAL
 EUT : AP
 POWER : 120Vac/60Hz
 MODEL : FR 791302
 MOME : 11a Tx_Ch149;5745MHz
 Data Rate: 54

	Freq	Level	Over	Limit	ReadAntenna	Cable	Preamp	Ant	Table	
	MHz	dBuV/m	dB	dBuV/m	dBuV	dB/m	dB	dB	cm	deg
1 X	5745.000	103.90			97.98	33.94	6.02	34.05	100	0 Peak
2 @	5745.000	91.60			85.68	33.94	6.02	34.05	100	25 Average
3	8444.000	55.28	-18.72	74.00	45.18	37.43	6.98	34.32	100	0 Peak
4	8444.000	44.87	-9.13	54.00	34.77	37.43	6.98	34.32	100	39 Average
5	11490.000	42.81	-31.19	74.00	80.99	-11.73	7.84	34.30	100	0 Peak
6	17229.000	38.47	-35.53	74.00	73.92	-11.07	9.42	33.81	100	0 Peak

Remark:

1. "1" represents the Fundamental Signal
2. "2" represents the Fundamental Signal



Test Mode : Mode 8
Polarization : Horizontal (30MHz-1GHz)

The test that passed at minimum margin was marked by the boldface in the following table.

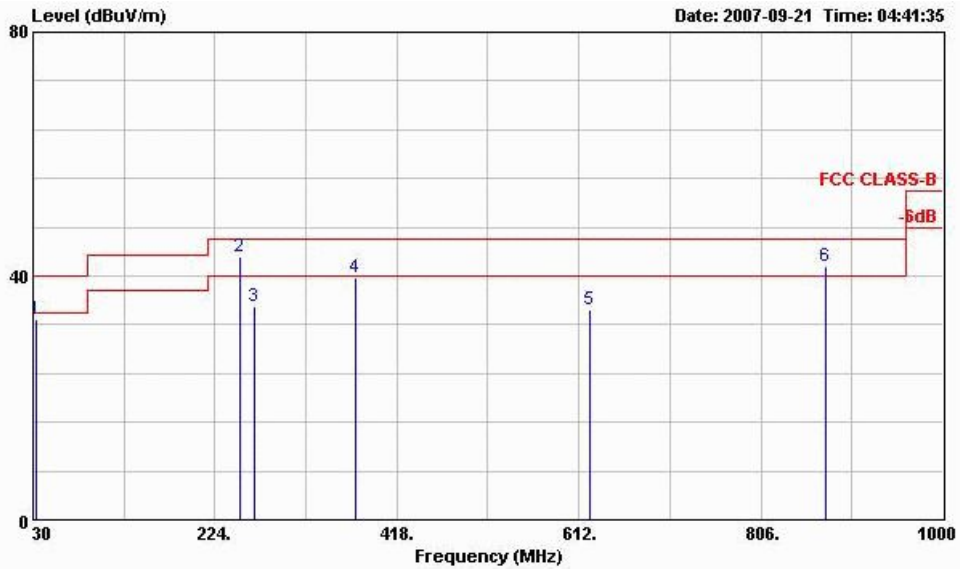

Site : 03CH04-HY
Condition: FCC CLASS-B 3m ANT2724 HORIZONTAL
EUT : AP
POWER : 120Vac/60Hz
MODEL : FR 791302
MOME : 11a Tx_Ch157;5785MHz
Data Rate: 54

	Freq	Level	Over	Limit	ReadAntenna	Cable	Preamp	Ant	Table		
	MHz	dBuV/m	Limit	Line	Level	Factor	Loss	Factor	Pos	Pos	
			dB	dBuV/m	dBuV	dB/m	dB	dB	cm	deg	
1	32.700	32.96	-7.04	40.00	42.40	16.33	0.90	26.66	---	---	Peak
2 !	250.500	43.20	-2.80	46.00	54.49	12.57	2.05	25.91	100	250	QP
3	266.250	34.99	-11.01	46.00	46.25	12.48	2.11	25.85	---	---	Peak
4	374.200	39.84	-6.16	46.00	48.71	14.88	2.49	26.24	---	---	Peak
5	624.100	34.55	-11.45	46.00	38.37	19.96	3.26	27.04	---	---	Peak
6 !	875.400	41.70	-4.30	46.00	41.83	22.62	3.92	26.67	---	---	Peak



Polarization : Horizontal (1GHz-25GHz)

■ The test that passed at minimum margin was marked by the boldface in the following table.

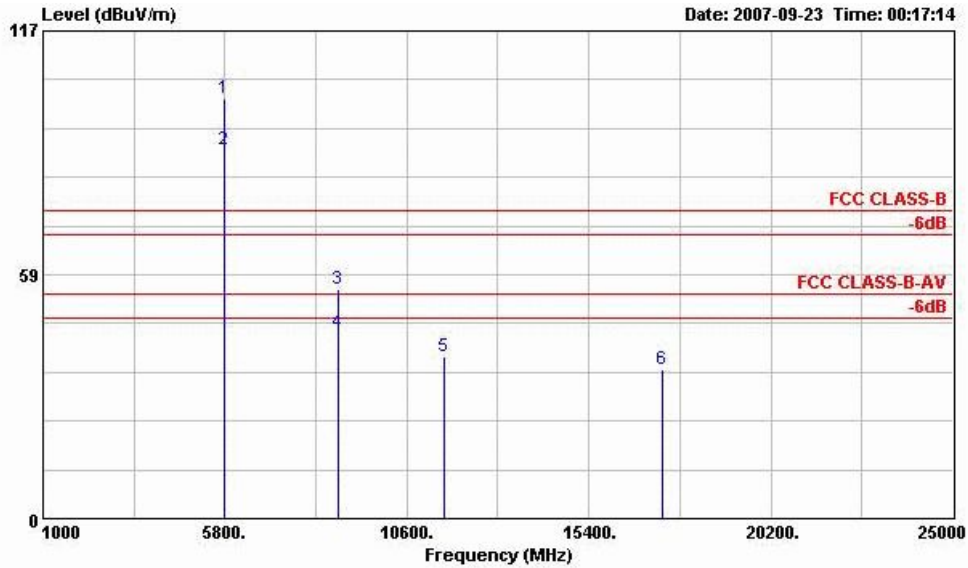

Site : 03CH04-HY
 Condition: FCC CLASS-B 3m HF-ANT-6903 HORIZONTAL
 EUT : AP
 POWER : 120Vac/60Hz
 MODEL : FR 791302
 MOME : 11a Tx_Ch157;5785MHz
 Data Rate: 54

	Freq	Level	Over	Limit	ReadAntenna	Cable	Preamp	Ant	Table	
	MHz	dBuV/m	Limit	Line	Level	Factor	Loss	Factor	Pos	Pos
			dB	dBuV/m	dBuV	dB/m	dB	dB	cm	deg
1 X	5785.000	100.67			94.72	33.97	6.02	34.04	100	0 Peak
2 X	5785.000	88.54			82.59	33.97	6.02	34.04	100	121 Average
3	8788.000	55.01	-18.99	74.00	44.63	37.84	7.16	34.62	100	0 Peak
4	8788.000	44.56	-9.44	54.00	34.18	37.84	7.16	34.62	100	39 Average
5	11574.000	39.03	-34.97	74.00	77.00	-11.49	7.85	34.33	100	0 Peak
6	17358.000	35.84	-38.16	74.00	71.67	-11.61	9.54	33.76	100	0 Peak

Remark:

1. "1" represents the Fundamental Signal
2. "2" represents the Fundamental Signal



Polarization : Vertical (30MHz-1GHz)

The test that passed at minimum margin was marked by the boldface in the following table.

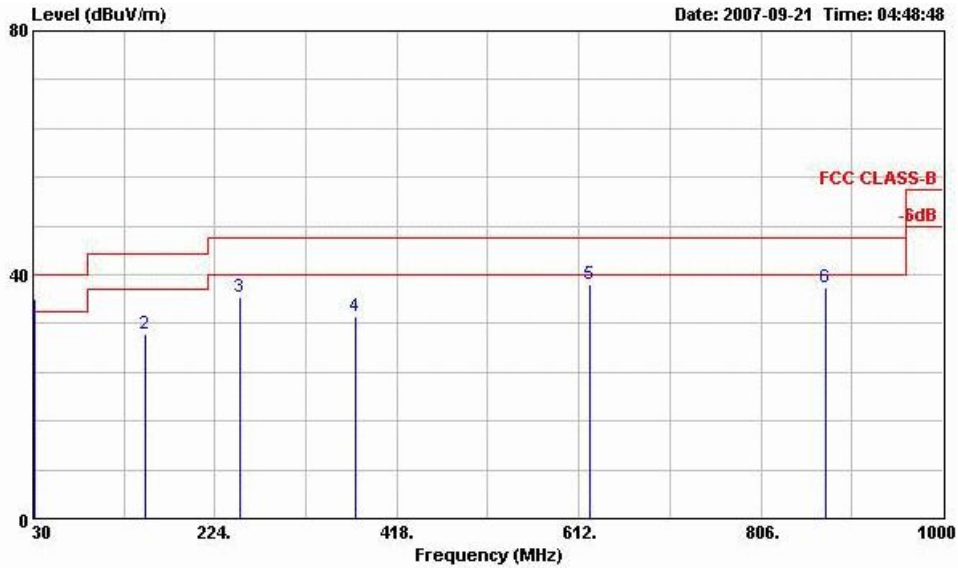

Site : 03CH04-HY
 Condition: FCC CLASS-B 3m ANT2724 VERTICAL
 EUT : AP
 POWER : 120Vac/60Hz
 MODEL : FR 791302
 MOME : 11a Tx_Ch157;5785MHz
 Data Rate: 54

	Freq	Level	Over Limit	Limit Line	ReadAntenna Level	Antenna Factor	Cable Loss	Preamp Factor	Ant Pos	Table Pos	Remark
	MHz	dBuV/m	dB	dBuV/m	dBuV	dB/m	dB	dB	cm	deg	
1 !	31.890	35.93	-4.07	40.00	45.36	16.34	0.89	26.66	100	70	QP
2	149.340	30.39	-13.11	43.50	44.26	10.75	1.66	26.28	---	---	Peak
3	250.050	36.31	-9.69	46.00	47.60	12.57	2.05	25.91	---	---	Peak
4	374.200	33.16	-12.84	46.00	42.03	14.88	2.49	26.24	---	---	Peak
5	624.100	38.32	-7.68	46.00	42.14	19.96	3.26	27.04	---	---	Peak
6	875.400	37.96	-8.04	46.00	38.09	22.62	3.92	26.67	---	---	Peak



Polarization : Vertical (1GHz-25GHz)

The test that passed at minimum margin was marked by the boldface in the following table.

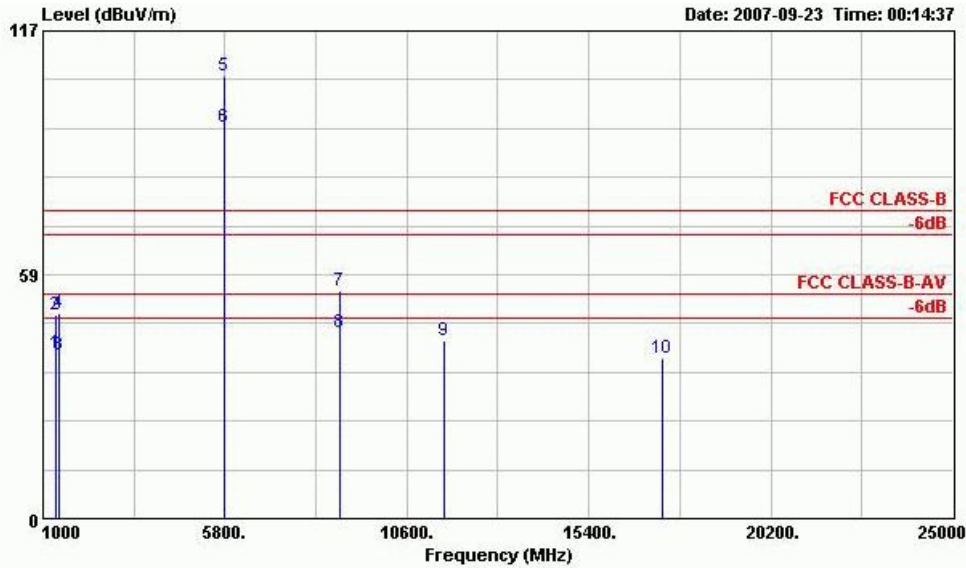

Site : 03CHO4-HY
 Condition: FCC CLASS-B 3m HF-ANT-6903 VERTICAL
 EUT : AP
 POWER : 120Vac/60Hz
 MODEL : FR 791302
 MOME : 11a Tx_Ch157;5785MHz
 Data Rate: 54

	Freq	Level	Over	Limit	ReadAntenna	Cable	Preamp	Ant	Table	
	MHz	dBUV/m	Limit	Line	Level	Factor	Loss	Pos	Pos	Remark
			dB	dBUV/m	dBuV	dB/m	dB	dB	cm	deg
1	1318.000	39.48	-14.52	54.00	45.46	25.12	2.71	33.81	100	335 Average
2	1318.000	49.03	-24.97	74.00	55.58	24.85	2.57	33.98	100	0 Peak
3	1430.000	39.39	-14.61	54.00	45.37	25.12	2.71	33.81	100	224 Average
4	1430.000	49.39	-24.61	74.00	55.37	25.12	2.71	33.81	100	0 Peak
5 X	5785.000	106.07			100.12	33.97	6.02	34.04	100	0 Peak
6 @	5785.000	94.10			88.15	33.97	6.02	34.04	100	19 Average
7	8838.000	54.82	-19.18	74.00	44.38	37.90	7.20	34.66	100	0 Peak
8	8838.000	44.75	-9.25	54.00	34.31	37.90	7.20	34.66	100	24 Average
9	11562.000	42.55	-31.45	74.00	80.56	-11.54	7.85	34.32	100	0 Peak
10	17346.000	38.49	-35.51	74.00	74.30	-11.57	9.52	33.76	100	0 Peak

Remark:

1. "5" represents the Fundamental Signal
2. "6" represents the Fundamental Signal



Test Mode : Mode 9
 Polarization : Horizontal (30MHz-1GHz)

The test that passed at minimum margin was marked by the boldface in the following table.

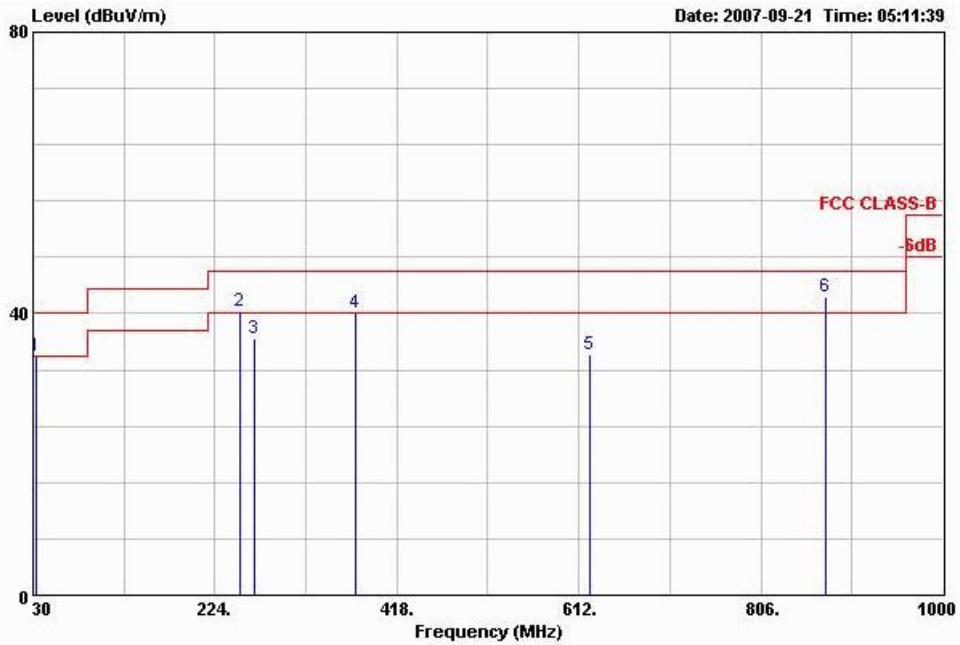

Site : 03CH04-HY
 Condition: FCC CLASS-B 3m ANT2724 HORIZONTAL
 EUT : AP
 POWER : 120Vac/60Hz
 MODEL : FR 791302
 MOME : 11a Tx_Ch165;5825MHz
 Data Rate: 54

	Freq	Level	Over Limit	Limit Line	ReadAntenna Level	Antenna Factor	Cable Loss	Preamp Factor	Ant Pos	Table Pos	Remark
	MHz	dBuV/m	dB	dBuV/m	dBuV	dB/m	dB	dB	cm	deg	
1	32.700	33.91	-6.09	40.00	43.35	16.33	0.90	26.66	---	---	Peak
2 !	250.500	40.30	-5.70	46.00	51.59	12.57	2.05	25.91	100	255	QP
3	266.250	36.43	-9.57	46.00	47.69	12.48	2.11	25.85	---	---	Peak
4 !	374.200	40.07	-5.93	46.00	48.94	14.88	2.49	26.24	---	---	Peak
5	624.100	34.26	-11.74	46.00	38.08	19.96	3.26	27.04	---	---	Peak
6 !	875.400	42.29	-3.71	46.00	42.42	22.62	3.92	26.67	100	126	Peak



Polarization : Horizontal (1GHz-25GHz)

■ The test that passed at minimum margin was marked by the boldface in the following table.

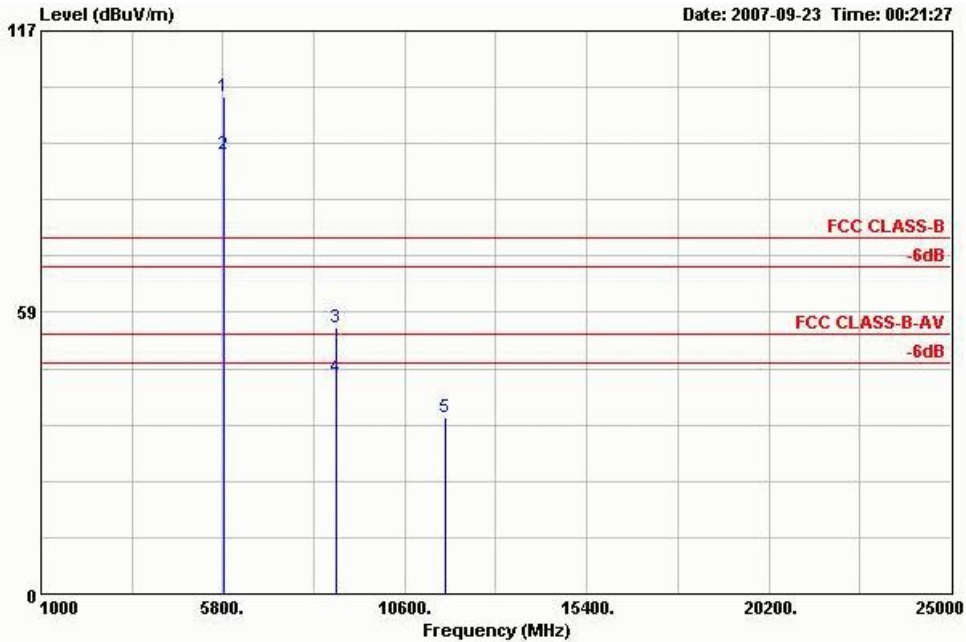

Site : 03CH04-HY
 Condition: FCC CLASS-B 3m HF-ANT-6903 HORIZONTAL
 EUT : AP
 POWER : 120Vac/60Hz
 MODEL : FR 791302
 MOMIE : 11a Tx_Ch165;5825MHz
 Data Rate: 54

	Freq	Level	Over	Limit	Read	Antenna	Cable	Preamp	Ant	Table	
	MHz	dBuV/m	dB	dBuV/m	Level	Factor	Loss	Factor	Pos	Pos	Remark
					dBuV	dB/m	dB	dB	cm	deg	
1 X	5825.000	103.21			97.23	34.00	6.02	34.04	100	0	Peak
2 X	5825.000	91.32			85.34	34.00	6.02	34.04	100	211	Average
3	8804.000	55.29	-18.71	74.00	44.90	37.86	7.17	34.64	100	0	Peak
4	8804.000	44.89	-9.11	54.00	34.50	37.86	7.17	34.64	100	34	Average
5	11649.000	36.59	-37.41	74.00	74.24	-11.14	7.86	34.36	100	0	Peak

Remark:

1. "1" represents the Fundamental Signal
2. "2" represents the Fundamental Signal



Polarization : Vertical (30MHz-1GHz)

The test that passed at minimum margin was marked by the boldface in the following table.

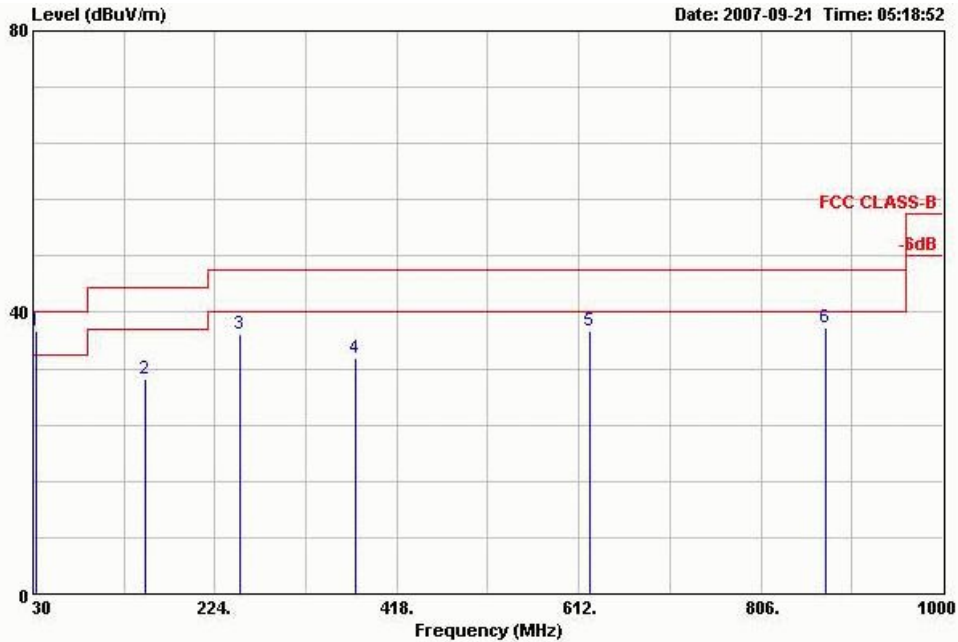

Site : 03CH04-HY
 Condition: FCC CLASS-B 3m ANT2724 VERTICAL
 EUT : AP
 POWER : 120Vac/60Hz
 MODEL : FR 791302
 MOME : 11a Tx_Ch165;5825MHz
 Data Rate: 54

	Freq	Level	Over	Limit	Read	Antenna	Cable	Preamp	Ant	Table	
	MHz	dBuV/m	Limit	Line	Level	Factor	Loss	Factor	Pos	Pos	Remark
			dB	dBuV/m	dBuV	dB/m	dB	dB	cm	deg	
1	32.700	37.35	-2.65	40.00	46.79	16.33	0.90	26.66	100	90	QP
2	149.610	30.58	-12.92	43.50	44.45	10.75	1.66	26.28	---	---	Peak
3	250.050	36.94	-9.06	46.00	48.23	12.57	2.05	25.91	---	---	Peak
4	374.200	33.49	-12.51	46.00	42.36	14.88	2.49	26.24	---	---	Peak
5	624.100	37.48	-8.52	46.00	41.30	19.96	3.26	27.04	---	---	Peak
6	875.400	37.73	-8.27	46.00	37.86	22.62	3.92	26.67	---	---	Peak



Polarization : Vertical (1GHz-25GHz)

The test that passed at minimum margin was marked by the boldface in the following table.

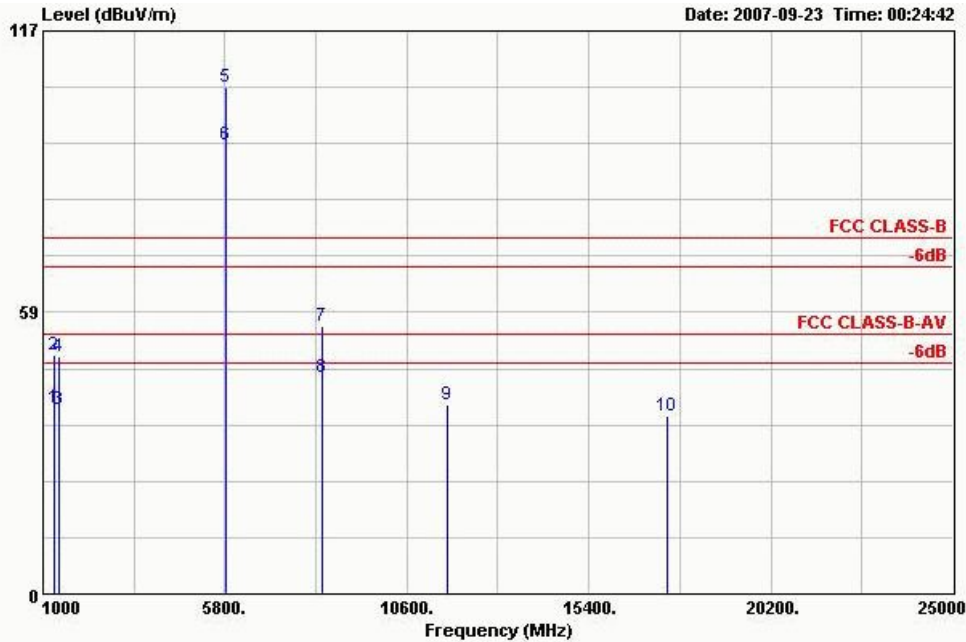

Site : 03CH04-HY
 Condition: FCC CLASS-B 3m HF-ANT-6903 VERTICAL
 EUT : AP
 POWER : 120Vac/60Hz
 MODEL : FR 791302
 MOME : 11a Tx_Ch165;5825MHz
 Data Rate: 54

	Freq	Level	Over	Limit	ReadAntenna	Cable	Preamp	Ant	Table	
	MHz	dBuV/m	dB	dBuV/m	Level	Loss	Factor	Pos	Pos	Remark
					dBuV	dB/m	dB	dB	cm	deg
1	1316.000	38.79	-15.21	54.00	45.34	24.85	2.57	33.98	100	338 Average
2	1316.000	49.59	-24.41	74.00	56.14	24.85	2.57	33.98	100	0 Peak
3	1406.000	38.45	-15.55	54.00	44.53	25.08	2.68	33.84	100	221 Average
4	1406.000	49.45	-24.55	74.00	55.53	25.08	2.68	33.84	100	0 Peak
5 X	5825.000	105.34			99.36	34.00	6.02	34.04	100	0 Peak
6 @	5825.000	93.43			87.45	34.00	6.02	34.04	100	21 Average
7	8350.000	55.51	-18.49	74.00	45.44	37.28	6.93	34.15	100	0 Peak
8	8350.000	45.11	-8.89	54.00	35.04	37.28	6.93	34.15	100	28 Average
9	11649.000	39.39	-34.61	74.00	77.04	-11.14	7.86	34.36	100	0 Peak
10	17478.000	36.87	-37.13	74.00	73.05	-12.12	9.64	33.71	100	0 Peak

Remark:

1. "5" represents the Fundamental Signal
2. "6" represents the Fundamental Signal



Test Mode : Mode 10
Polarization : Horizontal (30MHz-1GHz)

The test that passed at minimum margin was marked by the boldface in the following table.

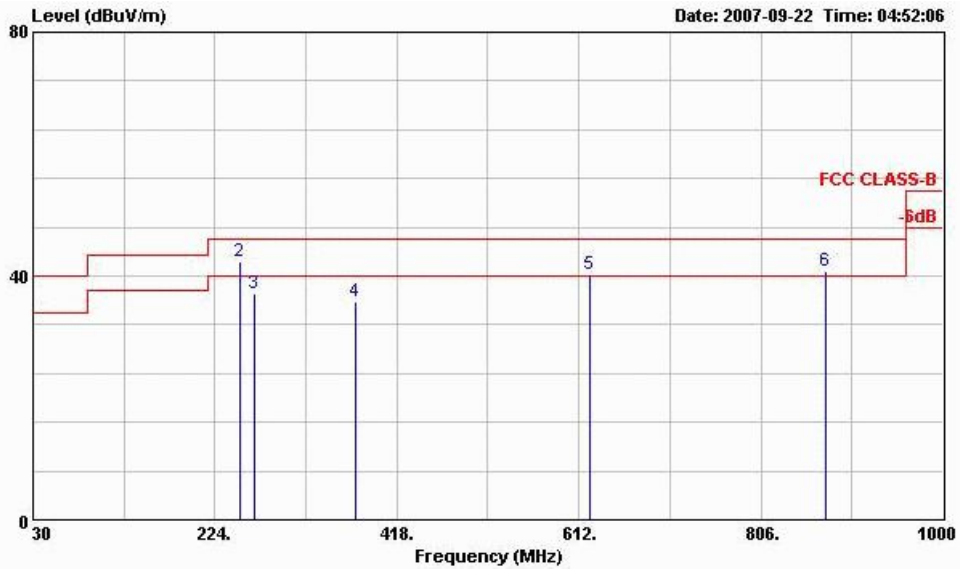

Site : 03CH04-HY
Condition: FCC CLASS-B 3m ANT2724 HORIZONTAL
EUT : AP
POWER : 120Vac/60Hz
MODEL : FR 791302
MOME : 11n (g) _Tx (20M) Ch01;2412MHz
Data Rate: 6.5

	Freq	Level	Over	Limit	ReadAntenna	Cable	Preamp	Ant	Table		
	MHz	dBuV/m	dB	dBuV/m	dBuV	dB/m	dB	dB	cm	deg	
1	30.810	32.52	-7.48	40.00	41.95	16.36	0.88	26.67	---	---	Peak
2 !	250.050	42.29	-3.71	46.00	53.58	12.57	2.05	25.91	100	245	Peak
3	266.250	37.04	-8.96	46.00	48.30	12.48	2.11	25.85	---	---	Peak
4	374.200	35.79	-10.21	46.00	44.66	14.88	2.49	26.24	---	---	Peak
5 !	624.100	40.37	-5.63	46.00	44.19	19.96	3.26	27.04	---	---	Peak
6 !	875.400	40.81	-5.19	46.00	40.94	22.62	3.92	26.67	---	---	Peak



Polarization : Horizontal (1GHz-25GHz)

■ The test that passed at minimum margin was marked by the boldface in the following table.

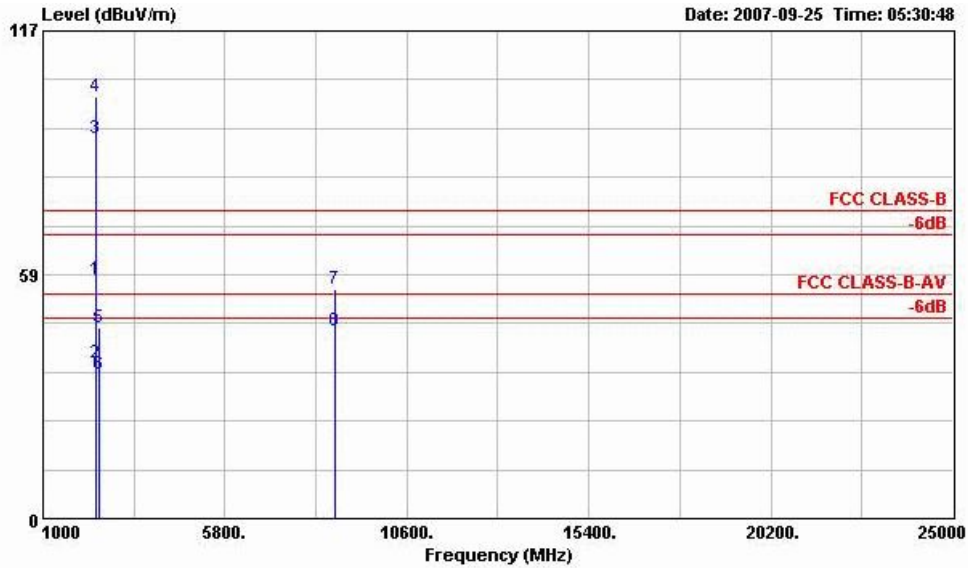

Site : 03CH04-HY
 Condition: FCC CLASS-B 3m HF-ANT-6903 HORIZONTAL
 EUT : AP
 POWER : 120Vac/60Hz
 MODEL : FR 791302
 MOME : 1ln(g)_Tx(20M)Ch01;2412MHz
 Data Rate: 6.5

	Freq	Level	Over	Limit	ReadAntenna	Cable	Preamp	Ant	Table	
	MHz	dBuV/m	Limit	Line	Level	Factor	Loss	Factor	Pos	Pos
			dB	dBuV/m	dBuV		dB	dB	cm	deg
1	2390.000	57.50	-16.50	74.00	59.47	28.07	3.74	33.78	100	0 Peak
2	2390.000	37.21	-16.79	54.00	39.18	28.07	3.74	33.78	100	256 Average
3 X	2412.000	91.15			93.06	28.11	3.76	33.78	100	256 Average
4 X	2412.000	101.11			103.02	28.11	3.76	33.78	100	0 Peak
5	2500.000	45.71	-28.29	74.00	47.37	28.30	3.84	33.80	100	0 Peak
6	2500.000	34.68	-19.32	54.00	36.34	28.30	3.84	33.80	100	256 Average
7	8709.000	55.12	-18.88	74.00	44.82	37.74	7.12	34.56	100	0 Peak
8	8709.000	45.06	-8.94	54.00	34.76	37.74	7.12	34.56	100	125 Average

Remark:

1. "3" represents the Fundamental Signal
2. "4" represents the Fundamental Signal



Polarization : Vertical (30MHz-1GHz)

The test that passed at minimum margin was marked by the boldface in the following table.

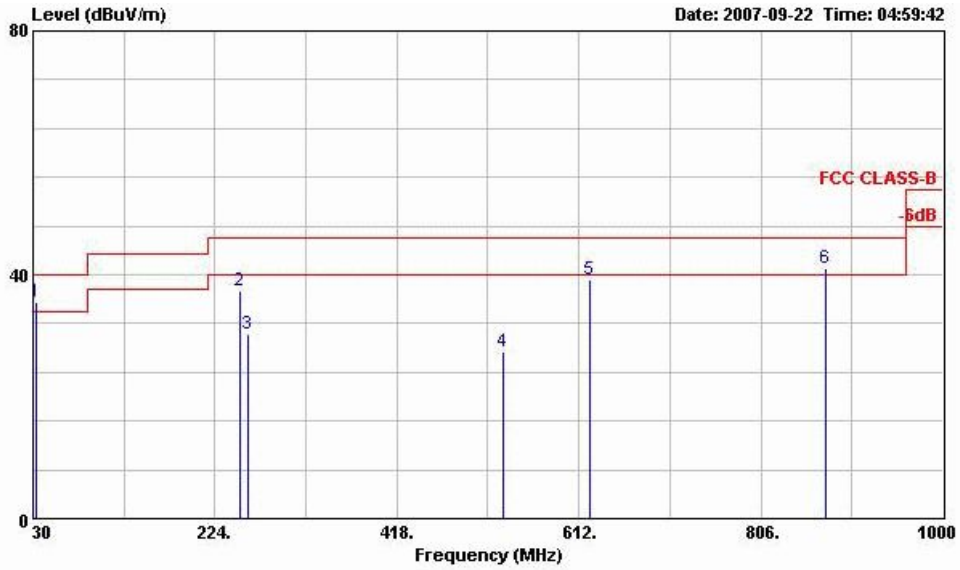

Site : 03CH04-HY
 Condition: FCC CLASS-B 3m ANT2724 VERTICAL
 EUT : AP
 POWER : 120Vac/60Hz
 MODEL : FR 791302
 MOME : 11n(g)_Tx(20M)Ch01;2412MHz
 Data Rate: 6.5

	Freq	Level	Over	Limit	ReadAntenna	Cable	Preamp	Ant	Table	
	MHz	dBuV/m	Limit	Line	Level	Factor	Loss	Factor	Pos	Pos
			dB	dBuV/m	dBuV	dB/m	dB	dB	cm	deg
1 !	32.970	35.53	-4.47	40.00	44.97	16.33	0.90	26.66	100	35 QP
2	250.050	37.45	-8.55	46.00	48.74	12.57	2.05	25.91	---	--- Peak
3	258.690	30.32	-15.68	46.00	41.59	12.52	2.08	25.88	---	--- Peak
4	531.700	27.41	-18.59	46.00	33.71	17.84	2.93	27.07	---	--- Peak
5	624.100	39.17	-6.83	46.00	42.99	19.96	3.26	27.04	---	--- Peak
6 !	875.400	41.15	-4.85	46.00	41.28	22.62	3.92	26.67	---	--- Peak



Polarization : Vertical (1GHz-25GHz)

The test that passed at minimum margin was marked by the boldface in the following table.

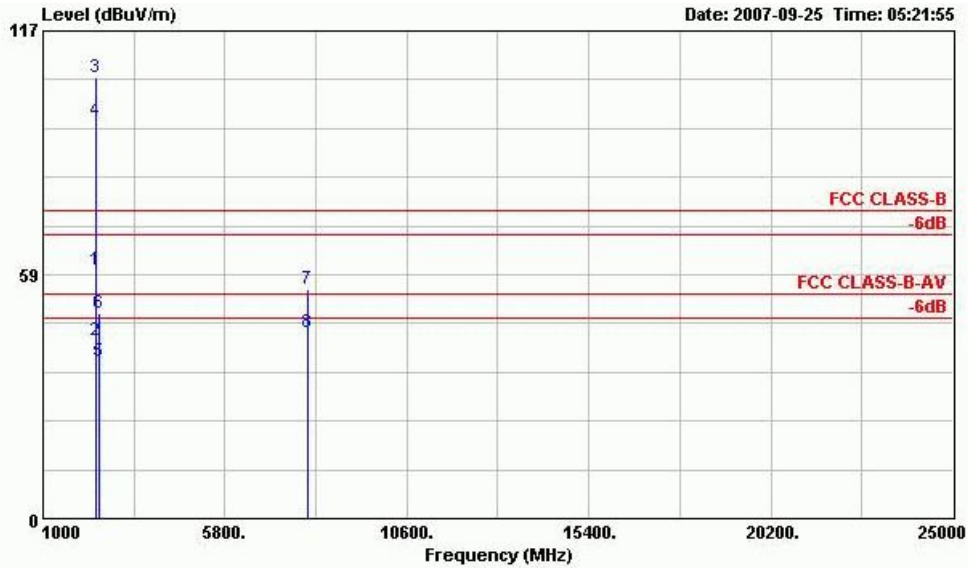

Site : 03CH04-HY
 Condition: FCC CLASS-B 3m HF-ANT-6903 VERTICAL
 EUT : AP
 POWER : 120Vac/60Hz
 MODEL : FR 791302
 MOME : 11n(g)_Tx(20M)Ch01;2412MHz
 Data Rate: 6.5

	Freq	Level	Over	Limit	ReadAntenna	Cable	Preamp	Ant	Table	
	MHz	dBuV/m	dB	dBuV/m	dBuV	dB/m	dB	dB	cm	deg
1	2390.000	59.70	-14.30	74.00	61.67	28.07	3.74	33.78	100	0 Peak
2	2390.000	42.79	-11.21	54.00	44.76	28.07	3.74	33.78	100	359 Average
3 X	2412.000	106.03			107.94	28.11	3.76	33.78	100	0 Peak
4 @	2412.000	95.46			97.37	28.11	3.76	33.78	100	359 Average
5	2484.000	37.62	-16.38	54.00	39.32	28.26	3.84	33.80	100	359 Average
6	2484.000	49.39	-24.61	74.00	51.09	28.26	3.84	33.80	100	0 Peak
7	7974.000	54.95	-19.05	74.00	45.05	36.77	6.75	33.62	100	0 Peak
8	7974.000	44.54	-9.46	54.00	34.64	36.77	6.75	33.62	100	162 Average

Remark:

1. "3" represents the Fundamental Signal
2. "4" represents the Fundamental Signal



Test Mode : Mode 11
Polarization : Horizontal (30MHz-1GHz)

The test that passed at minimum margin was marked by the boldface in the following table.

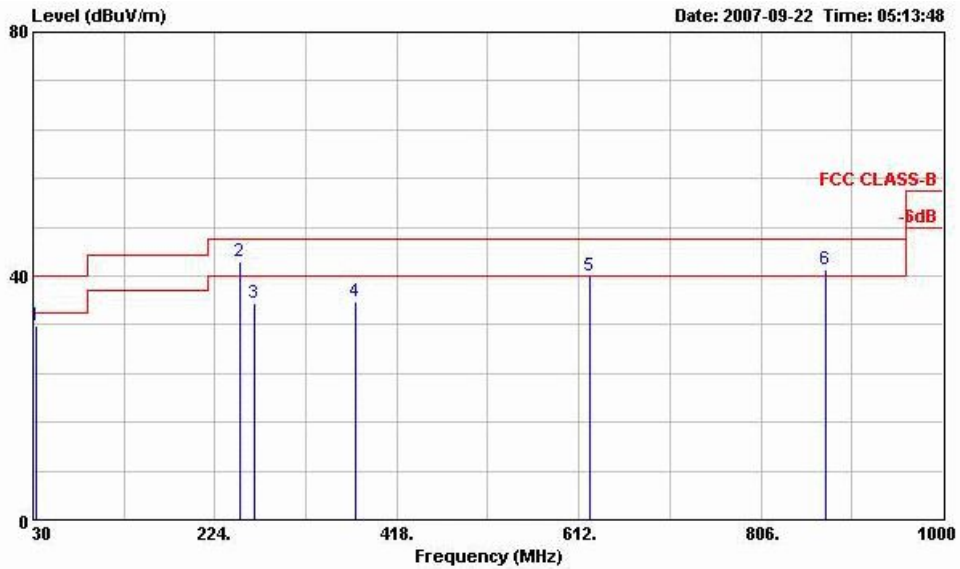

Site : 03CH04-HY
Condition: FCC CLASS-B 3m ANT2724 HORIZONTAL
EUT : AP
POWER : 120Vac/60Hz
MODEL : FR 791302
MOME : 11n (g) _Tx (20M) Ch06
Data Rate: 6.5

	Freq	Level	Over	Limit	ReadAntenna	Cable	Preamp	Ant	Table		
	MHz	dBuV/m	Limit	Line	Level	Loss	Factor	Pos	Pos	Remark	
			dB	dBuV/m	dBuV	dB	dB	cm	deg		
1	32.970	31.92	-8.08	40.00	41.36	16.33	0.90	26.66	---	---	Peak
2 !	250.050	42.33	-3.67	46.00	53.62	12.57	2.05	25.91	100	144	Peak
3	266.250	35.63	-10.37	46.00	46.89	12.48	2.11	25.85	---	---	Peak
4	374.200	35.73	-10.27	46.00	44.60	14.88	2.49	26.24	---	---	Peak
5 !	624.100	40.09	-5.91	46.00	43.91	19.96	3.26	27.04	---	---	Peak
6 !	875.400	40.98	-5.02	46.00	41.11	22.62	3.92	26.67	---	---	Peak



Polarization : Horizontal (1GHz-25GHz)

■ The test that passed at minimum margin was marked by the boldface in the following table.

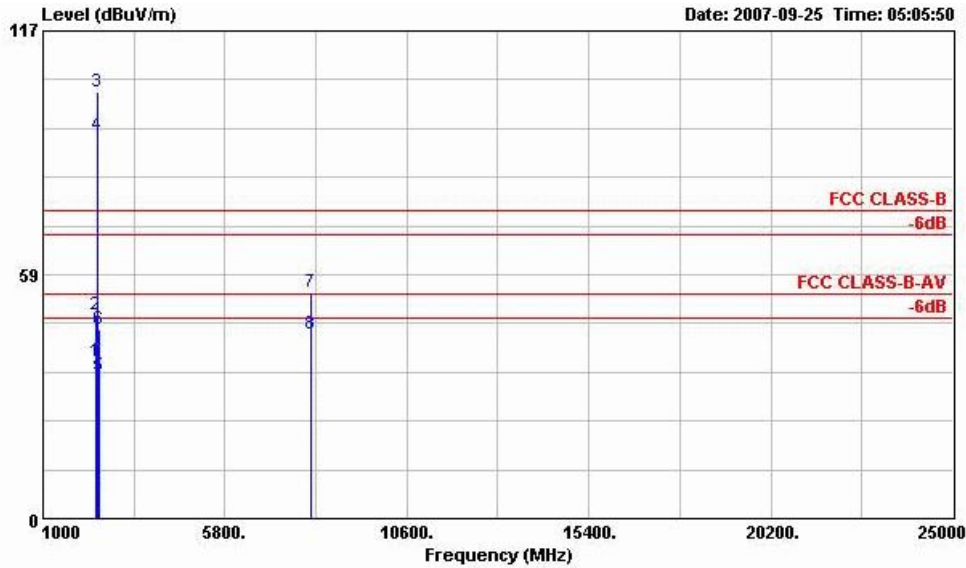

Site : 03CH04-HY
 Condition: FCC CLASS-B 3m HF-ANT-6903 HORIZONTAL
 EUT : AP
 POWER : 120Vac/60Hz
 MODEL : FR 791302
 MOME : 11n(g)_Tx(20M)Ch06
 Data Rate: 6.5

	Freq	Level	Over	Limit	ReadAntenna	Cable	Preamp	Ant	Table	
	MHz	dBuV/m	dB	dBuV/m	dBuV	dB/m	dB	dB	cm	deg
1	2390.000	37.62	-16.38	54.00	39.59	28.07	3.74	33.78	100	255 Average
2	2390.000	48.80	-25.20	74.00	50.77	28.07	3.74	33.78	100	0 Peak
3 X	2437.000	102.36			104.17	28.19	3.79	33.79	100	0 Peak
4 X	2437.000	91.81			93.62	28.19	3.79	33.79	100	255 Average
5	2494.000	34.21	-19.79	54.00	35.87	28.30	3.84	33.80	100	255 Average
6	2494.000	45.50	-28.50	74.00	47.16	28.30	3.84	33.80	100	0 Peak
7	8085.000	54.40	-19.60	74.00	44.41	36.92	6.80	33.73	100	0 Peak
8	8085.000	44.16	-9.84	54.00	34.17	36.92	6.80	33.73	100	265 Average

Remark:

1. "3" represents the Fundamental Signal
2. "4" represents the Fundamental Signal



Polarization : Vertical (30MHz-1GHz)

The test that passed at minimum margin was marked by the boldface in the following table.

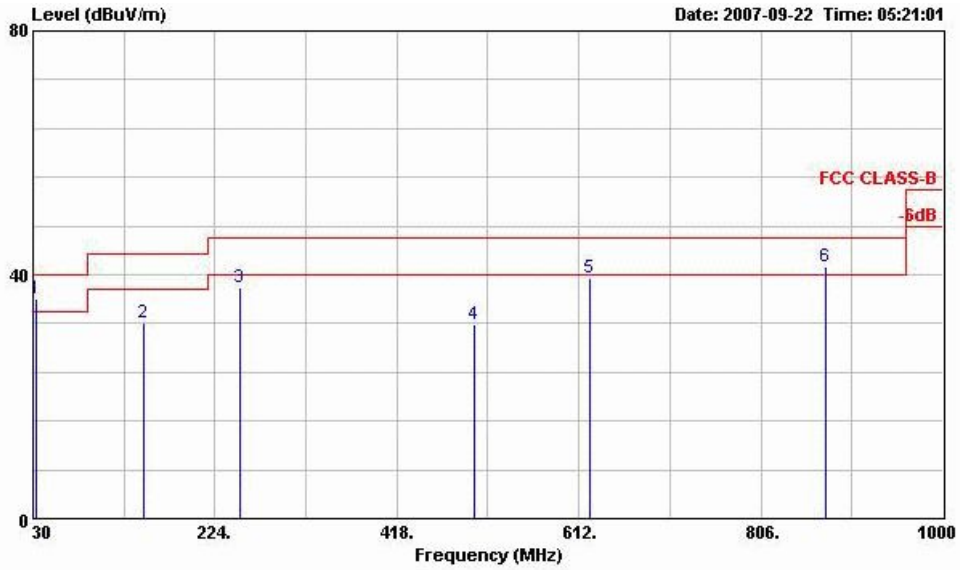

Site : 03CH04-HY
 Condition: FCC CLASS-B 3m ANT2724 VERTICAL
 EUT : AP
 POWER : 120Vac/60Hz
 MODEL : FR 791302
 MOME : 11n(g)_Tx(20M)Ch06
 Data Rate: 6.5

	Freq	Level	Over Limit	Limit Line	ReadAntenna Level	Antenna Factor	Cable Loss	Preamp Factor	Ant Pos	Table Pos	Remark
	MHz	dBuV/m	dB	dBuV/m	dBuV	dB/m	dB	dB	cm	deg	
1 !	32.970	36.10	-3.90	40.00	45.54	16.33	0.90	26.66	100	52	QP
2	148.260	32.01	-11.49	43.50	45.90	10.74	1.65	26.28	---	---	Peak
3	250.050	37.82	-8.18	46.00	49.11	12.57	2.05	25.91	---	---	Peak
4	500.200	31.79	-14.21	46.00	39.15	16.91	2.81	27.08	---	---	Peak
5	624.100	39.48	-6.52	46.00	43.30	19.96	3.26	27.04	---	---	Peak
6 !	875.400	41.36	-4.64	46.00	41.49	22.62	3.92	26.67	---	---	Peak



Polarization : Vertical (1GHz-25GHz)

The test that passed at minimum margin was marked by the boldface in the following table.

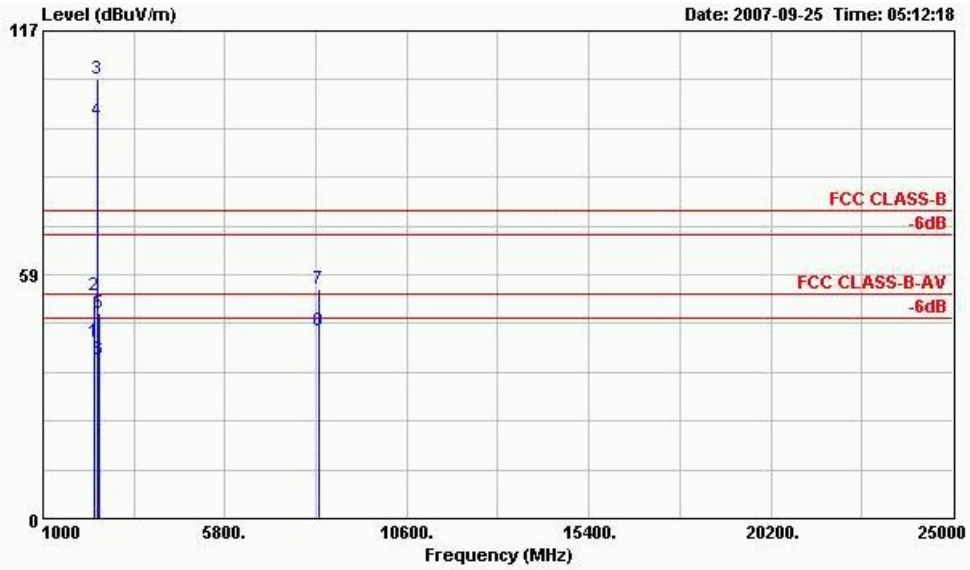

Site : 03CH04-HY
 Condition: FCC CLASS-B 3m HF-ANT-6903 VERTICAL
 EUT : AP
 POWER : 120Vac/60Hz
 MODEL : FR 791302
 MOME : 11n(g)_Tx(20M)Ch06
 Data Rate: 6.5

	Freq	Level	Over	Limit	ReadAntenna	Cable	Preamp	Ant	Table	
	MHz	dBuV/m	dB	dBuV/m	dBuV	dB/m	dB	dB	cm	deg
1	2374.000	42.21	-11.79	54.00	44.24	28.03	3.71	33.78	100	22 Average
2	2374.000	53.42	-20.58	74.00	55.45	28.03	3.71	33.78	100	0 Peak
3 X	2437.000	105.50			107.31	28.19	3.79	33.79	100	0 Peak
4 @	2437.000	95.39			97.20	28.19	3.79	33.79	100	22 Average
5	2484.000	49.32	-24.68	74.00	51.02	28.26	3.84	33.80	100	0 Peak
6	2484.000	38.01	-15.99	54.00	39.71	28.26	3.84	33.80	100	22 Average
7	8298.000	55.12	-18.88	74.00	45.06	37.21	6.91	34.06	100	0 Peak
8	8298.000	45.03	-8.97	54.00	34.97	37.21	6.91	34.06	100	145 Average

Remark:

1. "3" represents the Fundamental Signal
2. "4" represents the Fundamental Signal



Test Mode : Mode 12
Polarization : Horizontal (30MHz-1GHz)

The test that passed at minimum margin was marked by the boldface in the following table.

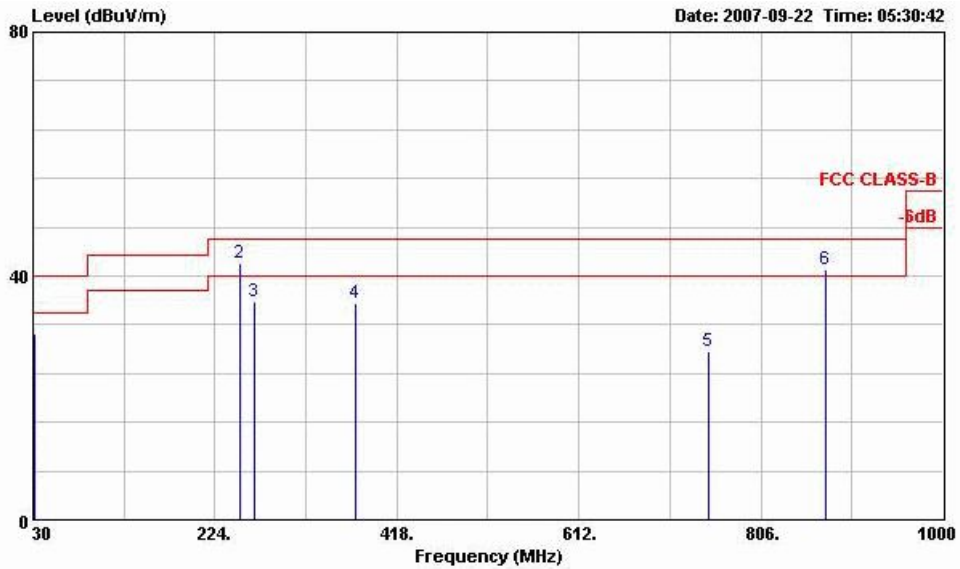

Site : 03CH04-HY
Condition: FCC CLASS-B 3m ANT2724 HORIZONTAL
EUT : AP
POWER : 120Vac/60Hz
MODEL : FR 791302
MOME : 11n (g) _Tx (20M) Ch11
Data Rate: 6.5

	Freq	Level	Over	Limit	ReadAntenna	Cable	Preamp	Ant	Table	
	MHz	dBuV/m	Limit	Line	Level	Loss	Factor	Pos	Pos	Remark
			dB	dBuV/m	dBuV	dB	dB	cm	deg	
1	31.080	30.59	-9.41	40.00	40.02	16.36	0.88	26.67	---	Peak
2 !	250.050	41.98	-4.02	46.00	53.27	12.57	2.05	25.91	100	19 Peak
3	266.250	35.90	-10.10	46.00	47.16	12.48	2.11	25.85	---	Peak
4	374.200	35.56	-10.44	46.00	44.43	14.88	2.49	26.24	---	Peak
5	750.100	27.64	-18.36	46.00	31.00	20.00	3.56	26.91	---	Peak
6 !	875.400	40.96	-5.04	46.00	41.09	22.62	3.92	26.67	---	Peak



Polarization : Horizontal (1GHz-25GHz)

■ The test that passed at minimum margin was marked by the boldface in the following table.

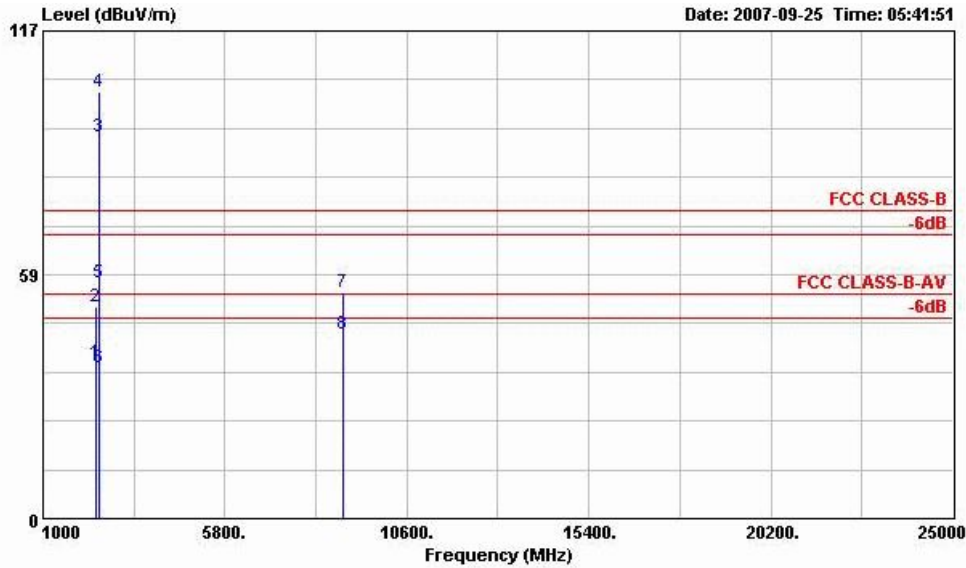

Site : 03CH04-HY
 Condition: FCC CLASS-B 3m HF-ANT-6903 HORIZONTAL
 EUT : AP
 POWER : 120Vac/60Hz
 MODEL : FR 791302
 MOME : 1ln(g)_Tx(20M)Ch11
 Data Rate: 6.5

	Freq	Level	Over	Limit	ReadAntenna	Cable	Preamp	Ant	Table	
	MHz	dBuV/m	dB	dBuV/m	dBuV	dB/m	dB	dB	cm	deg
1	2382.000	37.50	-16.50	54.00	39.50	28.03	3.74	33.78	100	262 Average
2	2382.000	50.87	-23.13	74.00	52.87	28.03	3.74	33.78	100	0 Peak
3 X	2462.000	91.76			93.51	28.22	3.81	33.79	100	262 Average
4 X	2462.000	102.46			104.21	28.22	3.81	33.79	100	0 Peak
5	2483.500	56.60	-17.40	74.00	58.30	28.26	3.84	33.80	100	0 Peak
6	2483.500	36.32	-17.68	54.00	38.02	28.26	3.84	33.80	100	262 Average
7	8913.000	54.45	-19.55	74.00	43.96	37.98	7.23	34.72	100	0 Peak
8	8913.000	44.20	-9.80	54.00	33.71	37.98	7.23	34.72	100	245 Average

Remark:

1. "3" represents the Fundamental Signal
2. "4" represents the Fundamental Signal



Polarization : Vertical (30MHz-1GHz)

The test that passed at minimum margin was marked by the boldface in the following table.

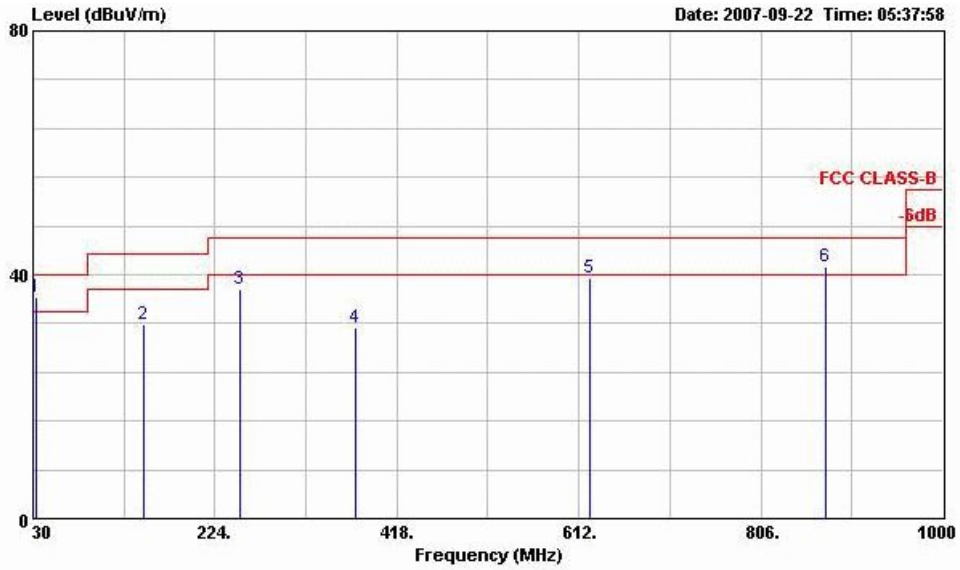

Site : 03CHO4-HY
 Condition: FCC CLASS-B 3m ANT2724 VERTICAL
 EUT : AP
 POWER : 120Vac/60Hz
 MODEL : FR 791302
 MOME : 1ln(g)_Tx(20M)Ch11
 Data Rate: 6.5

	Freq	Level	Over	Limit	ReadAntenna	Cable	Preamp	Ant	Table	
	MHz	dBuV/m	Limit	Line	Level	Factor	Loss	Pos	Pos	Remark
			dB	dBuV/m	dBuV	dB/m	dB	dB	cm	deg
1 !	32.970	36.44	-3.56	40.00	45.88	16.33	0.90	26.66	100	48 QP
2	148.530	31.91	-11.59	43.50	45.80	10.74	1.66	26.28	---	--- Peak
3	250.050	37.67	-8.33	46.00	48.96	12.57	2.05	25.91	---	--- Peak
4	374.200	31.34	-14.66	46.00	40.21	14.88	2.49	26.24	---	--- Peak
5	624.100	39.55	-6.45	46.00	43.37	19.96	3.26	27.04	---	--- Peak
6 !	875.400	41.29	-4.71	46.00	41.42	22.62	3.92	26.67	---	--- Peak



Polarization : Vertical (1GHz-25GHz)

The test that passed at minimum margin was marked by the boldface in the following table.

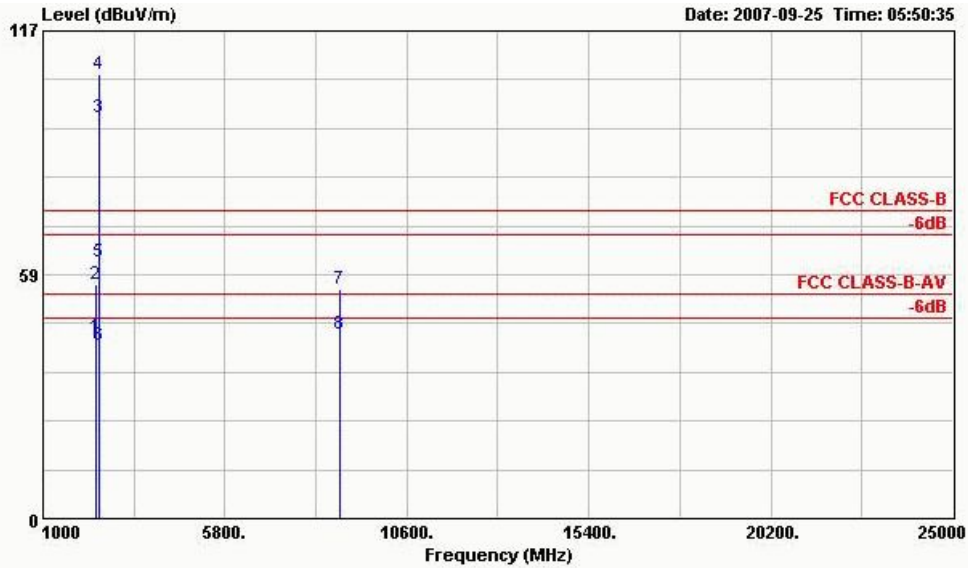

Site : 03CH04-HY
 Condition: FCC CLASS-B 3m HF-ANT-6903 VERTICAL
 EUT : AP
 POWER : 120Vac/60Hz
 MODEL : FR 791302
 MOME : 1ln(g)_Tx(20M)Ch11
 Data Rate: 6.5

	Freq	Level	Over Limit	Limit Line	ReadAntenna Level	Antenna Factor	Cable Loss	Preamp Factor	Ant Pos	Table Pos	Remark
	MHz	dBuV/m	dB	dBuV/m	dBuV	dB/m	dB	dB	cm	deg	
1	2388.000	43.50	-10.50	54.00	45.46	28.07	3.74	33.78	100	22	Average
2	2388.000	56.09	-17.91	74.00	58.05	28.07	3.74	33.78	100	0	Peak
3 @	2462.000	96.07			97.82	28.22	3.81	33.79	100	22	Average
4 X	2462.000	106.66			108.41	28.22	3.81	33.79	100	0	Peak
5	2484.420	61.70	-12.30	74.00	63.40	28.26	3.84	33.80	100	0	Peak
6	2484.420	41.70	-12.30	54.00	43.40	28.26	3.84	33.80	100	22	Average
7	8850.000	54.96	-19.04	74.00	44.52	37.92	7.20	34.68	100	0	Peak
8	8850.000	44.20	-9.80	54.00	33.76	37.92	7.20	34.68	100	235	Average

Remark:

1. "3" represents the Fundamental Signal
2. "4" represents the Fundamental Signal



Test Mode : Mode 13

Polarization : Horizontal (30MHz-1GHz)

The test that passed at minimum margin was marked by the boldface in the following table.

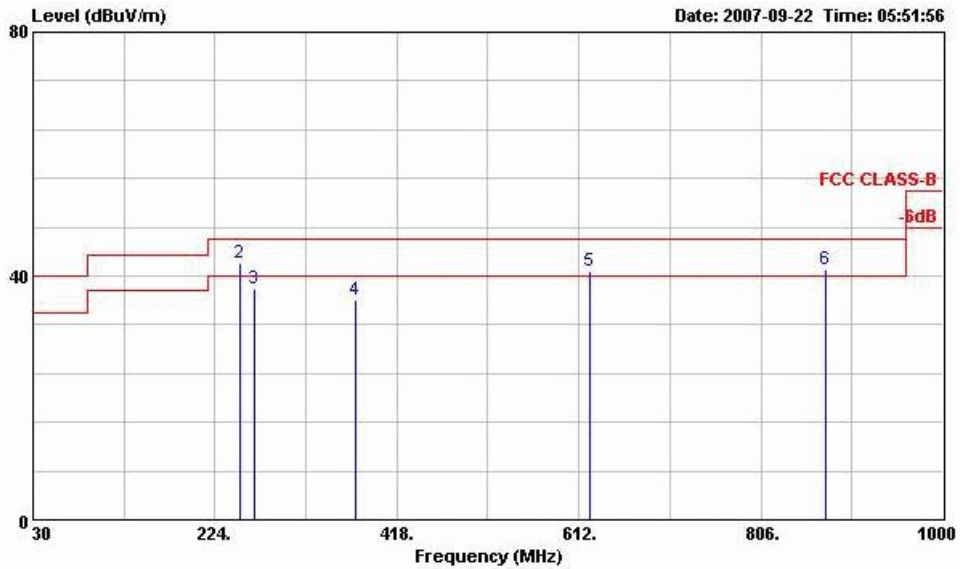

Site : 03CH04-HY
 Condition: FCC CLASS-B 3m ANT2724 HORIZONTAL
 EUT : AP
 POWER : 120Vac/60Hz
 MODEL : FR 791302
 MOME : 11n (g) _Tx (40M) Ch03
 Data Rate: 13.5

	Freq	Level	Over	Limit	ReadAntenna	Cable	Preamp	Ant	Table		
	MHz	dBuV/m	Limit	Line	Level	Loss	Factor	Pos	Pos	Remark	
			dB	dBuV/m	dBuV	dB	dB	cm	deg		
1	30.810	32.38	-7.62	40.00	41.81	16.36	0.88	26.67	---	---	Peak
2 !	250.050	42.10	-3.90	46.00	53.39	12.57	2.05	25.91	100	264	Peak
3	266.250	37.87	-8.13	46.00	49.13	12.48	2.11	25.85	---	---	Peak
4	374.200	35.98	-10.02	46.00	44.85	14.88	2.49	26.24	---	---	Peak
5 !	624.100	40.74	-5.26	46.00	44.56	19.96	3.26	27.04	---	---	Peak
6 !	875.400	41.18	-4.82	46.00	41.31	22.62	3.92	26.67	---	---	Peak



Polarization : Horizontal (1GHz-25GHz)

■ The test that passed at minimum margin was marked by the boldface in the following table.

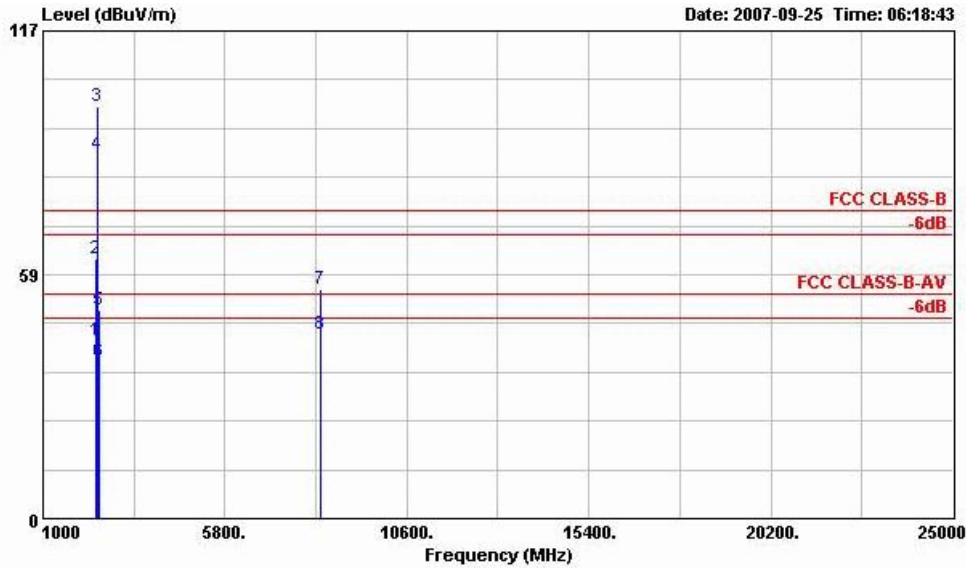

Site : 03CH04-HY
 Condition: FCC CLASS-B 3m HF-ANT-6903 HORIZONTAL
 EUT : AP
 POWER : 120Vac/60Hz
 MODEL : FR 791302
 MOME : 11n(g)_Tx(40M)Ch03
 Data Rate: 13.5

	Freq	Level	Over	Limit	ReadAntenna	Cable	Preamp	Ant	Table	
	MHz	dBuV/m	dB	dBuV/m	dBuV	dB/m	dB	dB	cm	deg
1	2390.000	42.67	-11.33	54.00	44.64	28.07	3.74	33.78	100	261 Average
2	2390.000	62.23	-11.77	74.00	64.20	28.07	3.74	33.78	100	0 Peak
3 X	2422.000	99.05			100.92	28.15	3.76	33.79	100	0 Peak
4 X	2422.000	87.39			89.26	28.15	3.76	33.79	100	261 Average
5	2485.180	49.93	-24.07	74.00	51.63	28.26	3.84	33.80	100	0 Peak
6	2485.180	37.55	-16.45	54.00	39.25	28.26	3.84	33.80	100	261 Average
7	8322.000	54.85	-19.15	74.00	44.77	37.26	6.92	34.11	100	0 Peak
8	8322.000	44.21	-9.79	54.00	34.13	37.26	6.92	34.11	100	24 Average

Remark:

1. "3" represents the Fundamental Signal
2. "4" represents the Fundamental Signal



Polarization : Vertical (30MHz-1GHz)

The test that passed at minimum margin was marked by the boldface in the following table.

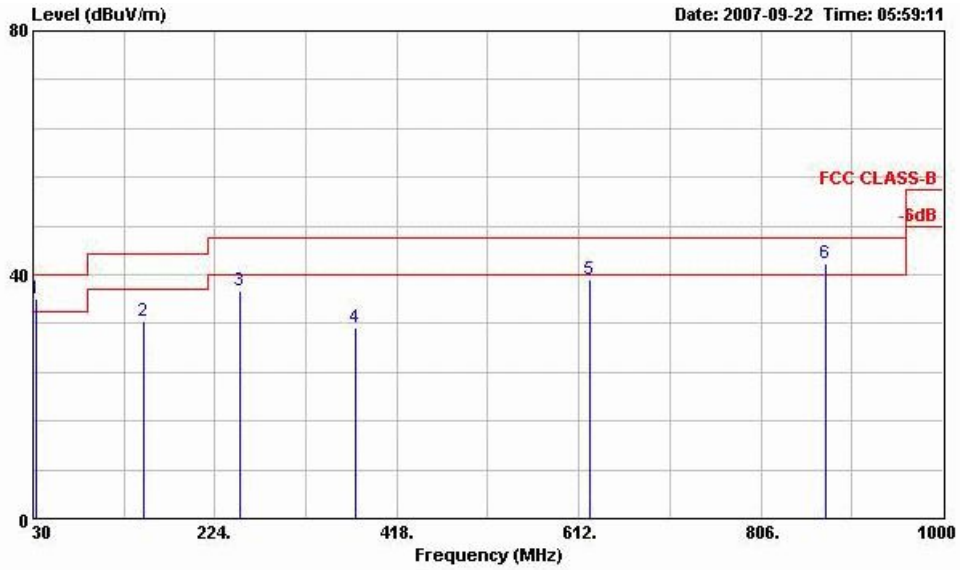

Site : 03CH04-HY
 Condition: FCC CLASS-B 3m ANT2724 VERTICAL
 EUT : AP
 POWER : 120Vac/60Hz
 MODEL : FR 791302
 MOME : 1ln(g)_Tx(40M)Ch03
 Data Rate: 13.5

	Freq	Level	Over	Limit	ReadAntenna	Cable	Preamp	Ant	Table	
	MHz	dBuV/m	Limit	Line	Level	Factor	Loss	Factor	Pos	Pos
			dB	dBuV/m	dBuV	dB/m	dB	dB	cm	deg
1 !	32.970	35.96	-4.04	40.00	45.40	16.33	0.90	26.66	100	53 QP
2	148.530	32.47	-11.03	43.50	46.36	10.74	1.66	26.28	---	---
3	250.050	37.33	-8.67	46.00	48.62	12.57	2.05	25.91	---	---
4	374.200	31.36	-14.64	46.00	40.23	14.88	2.49	26.24	---	---
5	624.100	39.29	-6.71	46.00	43.11	19.96	3.26	27.04	---	---
6 !	875.400	41.77	-4.23	46.00	41.90	22.62	3.92	26.67	---	---



Polarization : Vertical (1GHz-25GHz)

The test that passed at minimum margin was marked by the boldface in the following table.

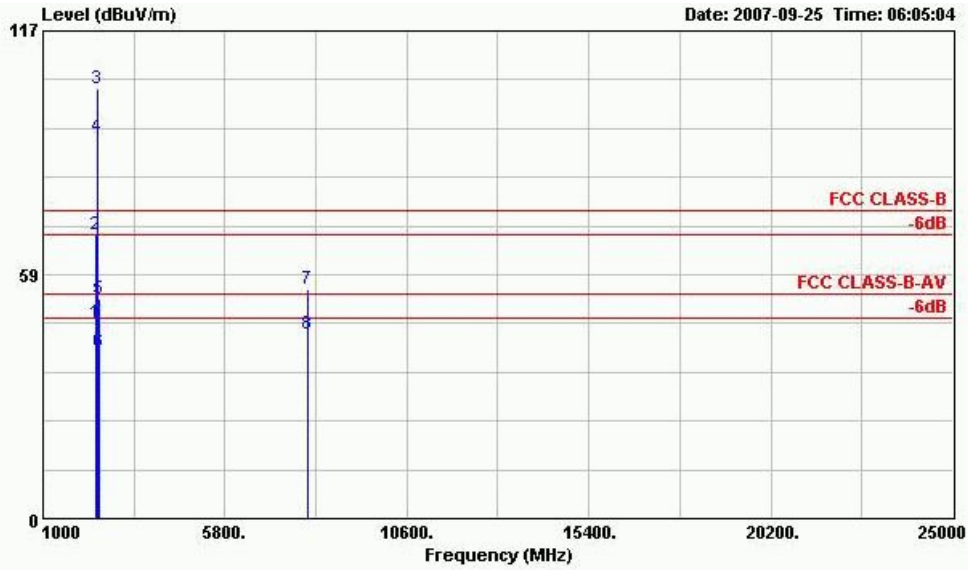

Site : 03CH04-HY
 Condition: FCC CLASS-B 3m HF-ANT-6903 VERTICAL
 EUT : AP
 POWER : 120Vac/60Hz
 MODEL : FR 791302
 MOME : 11n(g)_Tx(40M)Ch03
 Data Rate: 13.5

	Freq	Level	Over	Limit	ReadAntenna	Cable	Preamp	Ant	Table	
	MHz	dBuV/m	Limit	Line	Level	Factor	Loss	Factor	Pos	Pos
			dB	dBuV/m	dBuV	dB/m	dB	dB	cm	deg
1	2390.000	46.84	-7.16	54.00	48.81	28.07	3.74	33.78	100	357 Average
2 !	2390.000	68.15	-5.85	74.00	70.12	28.07	3.74	33.78	100	0 Peak
3 X	2422.000	103.02			104.90	28.15	3.76	33.79	100	0 Peak
4 @	2422.000	91.60			93.47	28.15	3.76	33.79	100	357 Average
5	2485.180	52.63	-21.37	74.00	54.33	28.26	3.84	33.80	100	0 Peak
6	2485.180	40.19	-13.81	54.00	41.89	28.26	3.84	33.80	100	357 Average
7	7974.000	54.99	-19.01	74.00	45.09	36.77	6.75	33.62	100	0 Peak
8	7974.000	44.35	-9.65	54.00	34.45	36.77	6.75	33.62	100	156 Average

Remark:

1. "3" represents the Fundamental Signal
2. "4" represents the Fundamental Signal



Test Mode : Mode 14
 Polarization : Horizontal (30MHz-1GHz)

The test that passed at minimum margin was marked by the boldface in the following table.

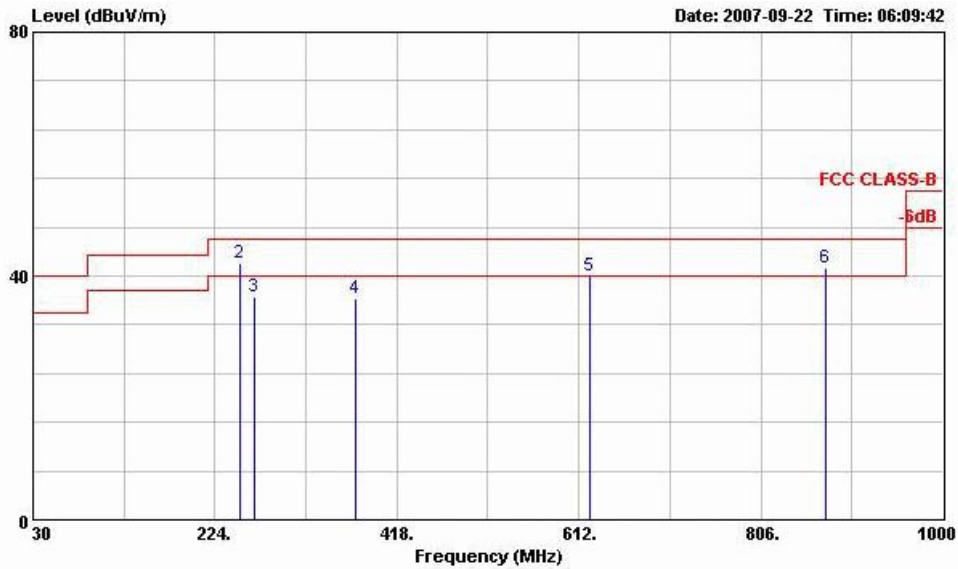

Site : 03CH04-HY
 Condition: FCC CLASS-B 3m ANT2724 HORIZONTAL
 EUT : AP
 POWER : 120Vac/60Hz
 MODEL : FR 791302
 MOME : 11n (g) _Tx (40M) Ch09
 Data Rate: 13.5

	Freq	Level	Over	Limit	ReadAntenna	Cable	Preamp	Ant	Table		
	MHz	dBuV/m	dB	dBuV/m	dBuV	dB/m	dB	dB	cm	deg	
1	30.810	31.37	-8.63	40.00	40.80	16.36	0.88	26.67	---	---	Peak
2 !	250.050	42.19	-3.81	46.00	53.48	12.57	2.05	25.91	100	232	Peak
3	266.250	36.58	-9.42	46.00	47.84	12.48	2.11	25.85	---	---	Peak
4	374.200	36.28	-9.72	46.00	45.15	14.88	2.49	26.24	---	---	Peak
5	624.100	39.92	-6.08	46.00	43.74	19.96	3.26	27.04	---	---	Peak
6 !	875.400	41.29	-4.71	46.00	41.42	22.62	3.92	26.67	---	---	Peak



Polarization : Horizontal (1GHz-25GHz)

■ The test that passed at minimum margin was marked by the boldface in the following table.

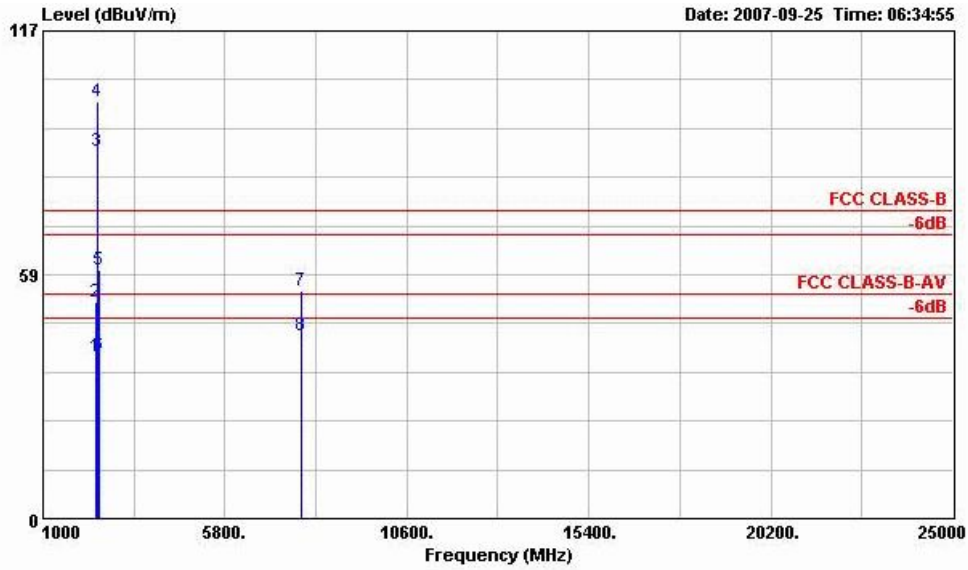

Site : 03CH04-HY
 Condition: FCC CLASS-B 3m HF-ANT-6903 HORIZONTAL
 EUT : AP
 POWER : 120Vac/60Hz
 MODEL : FR 791302
 MOME : 11n(g)_Tx(40M)Ch09
 Data Rate: 13.5

	Freq	Level	Over	Limit	ReadAntenna	Cable	Preamp	Ant	Table	
	MHz	dBuV/m	dB	dBuV/m	dBuV	dB/m	dB	dB	cm	deg
1	2388.000	39.02	-14.98	54.00	40.98	28.07	3.74	33.78	100	255 Average
2	2388.000	52.00	-22.00	74.00	53.96	28.07	3.74	33.78	100	0 Peak
3 X	2452.000	88.21			90.03	28.19	3.79	33.79	100	255 Average
4 X	2452.000	99.94			101.75	28.19	3.79	33.79	100	0 Peak
5	2483.500	59.59	-14.41	74.00	61.29	28.26	3.84	33.80	100	0 Peak
6	2483.500	39.33	-14.67	54.00	41.03	28.26	3.84	33.80	100	255 Average
7	7818.000	54.52	-19.48	74.00	44.86	36.65	6.68	33.68	100	0 Peak
8	7818.000	44.03	-9.97	54.00	34.37	36.65	6.68	33.68	100	23 Average

Remark:

1. "3" represents the Fundamental Signal
2. "4" represents the Fundamental Signal



Polarization : Vertical (30MHz-1GHz)

The test that passed at minimum margin was marked by the boldface in the following table.

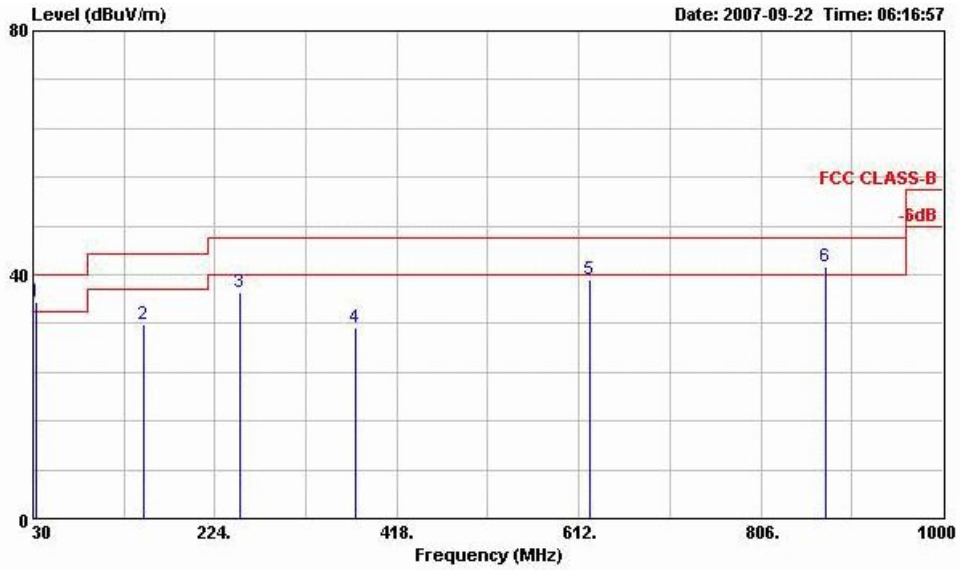

Site : 03CH04-HY
 Condition: FCC CLASS-B 3m ANT2724 VERTICAL
 EUT : AP
 POWER : 120Vac/60Hz
 MODEL : FR 791302
 MOME : 1ln(g)_Tx(40M)Ch09
 Data Rate: 13.5

	Freq	Level	Over	Limit	ReadAntenna	Cable	Preamp	Ant	Table	
	MHz	dBuV/m	Limit	Line	Level	Factor	Loss	Factor	Pos	Pos
			dB	dBuV/m	dBuV	dB/m	dB	dB	cm	deg
1 !	32.970	35.64	-4.36	40.00	45.08	16.33	0.90	26.66	100	58 QP
2	148.260	31.75	-11.75	43.50	45.64	10.74	1.65	26.28	---	--- Peak
3	250.050	37.23	-8.77	46.00	48.52	12.57	2.05	25.91	---	--- Peak
4	374.200	31.20	-14.80	46.00	40.07	14.88	2.49	26.24	---	--- Peak
5	624.100	39.22	-6.78	46.00	43.04	19.96	3.26	27.04	---	--- Peak
6 !	875.400	41.23	-4.77	46.00	41.36	22.62	3.92	26.67	---	--- Peak



Polarization : Vertical (1GHz-25GHz)

The test that passed at minimum margin was marked by the boldface in the following table.

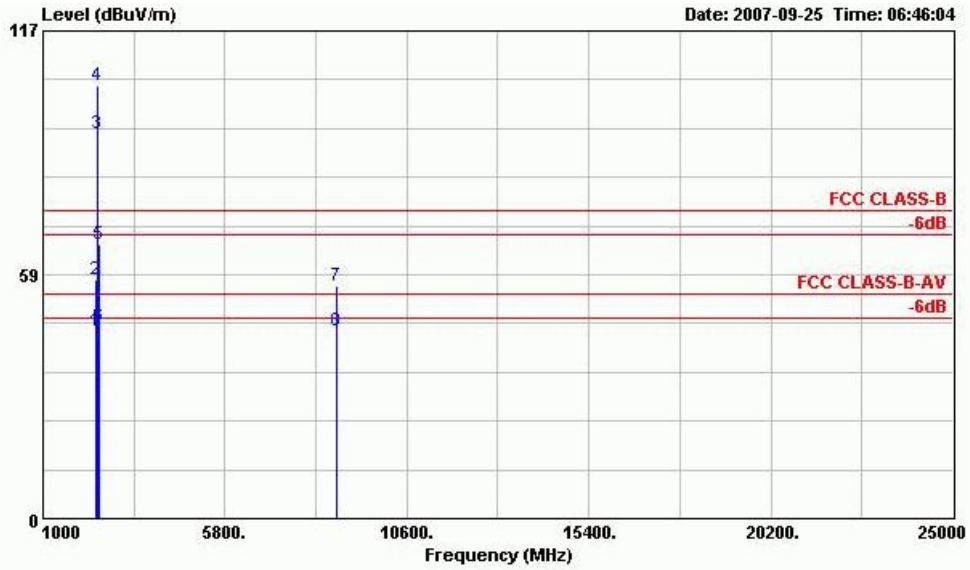

Site : 03CH04-HY
 Condition: FCC CLASS-B 3m HF-ANT-6903 VERTICAL
 EUT : AP
 POWER : 120Vac/60Hz
 MODEL : FR 791302
 MOME : 11n(g)_Tx(40M)Ch09
 Data Rate: 13.5

	Freq	Level	Over	Limit	ReadAntenna	Cable	Preamp	Ant	Table	
	MHz	dBuV/m	Limit	Line	Level	Factor	Loss	Factor	Pos	Pos
			dB	dBuV/m	dBuV	dB/m	dB	dB	cm	deg
1	2388.000	44.89	-9.11	54.00	46.85	28.07	3.74	33.78	100	3 Average
2	2388.000	57.33	-16.67	74.00	59.29	28.07	3.74	33.78	100	0 Peak
3 @	2452.000	92.40			94.22	28.19	3.79	33.79	100	3 Average
4 X	2452.000	104.10			105.92	28.19	3.79	33.79	100	0 Peak
5	2483.500	65.77	-8.23	74.00	67.47	28.26	3.84	33.80	100	0 Peak
6	2483.500	46.17	-7.83	54.00	47.87	28.26	3.84	33.80	100	3 Average
7	8766.000	55.65	-18.35	74.00	45.29	37.82	7.16	34.62	100	0 Peak
8	8766.000	45.11	-8.89	54.00	34.75	37.82	7.16	34.62	100	224 Average

Remark:

1. "3" represents the Fundamental Signal
2. "4" represents the Fundamental Signal