

承认书

SPECIFICATION FOR APPROVAL

客户名称 (CUSTOMER) : LK

客户料号 (PART NO.) : _____

品名 (DESCRIPTION) : A11线圈+磁片 A11 coil + disk

规格 (SPECIFICATION) : 20.5*43, G44X0.8, 引线lead 10MM

日期 (DATE) : 20211119

本司确认 (TRX APPROVAL)		
制作manufacture	审核 examine	承认日期Date of recognition
檀天龙	邱志辉	20211119
客户确认 (CUSTOMER APPROVAL)		
工程 ENGINEERING	批准 Give permission	承认日期Date of recognition
确认结果 (Result): <input type="checkbox"/> 合格 pass <input type="checkbox"/> 不合格 fail <input type="checkbox"/> 其它 other		

东莞市德弗力五金电子材料有限公司

Dongguan city DFL Electronic Technology Co.,LTD

电话 TEL: 0769-86016320 传真 FAX: 0769-86372427

东莞市德弗力五金电子材料有限公司

Dongguan city DFL Electronic Technology Co.,LTD

SPECIFICATION

产品型号: DESC	JYC-Y20.5*43-10-FR	版本 Rev:A	Description:	All coil+
				hardmagnetic
			Date:	20211119

一、尺寸DIMENSION: (mm)

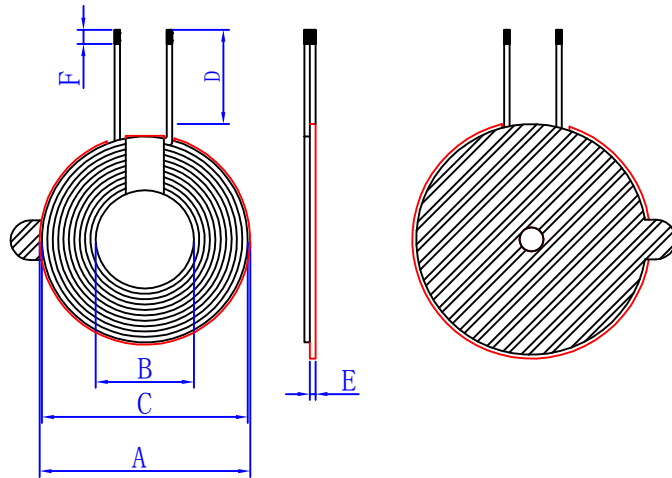

A	44.0±1.0
B	20.5±1.0
C	43.0±1.5
D	10.0±2.0
E	0.8±0.2
F	3.5±1.5
G	
H	
I	
J	
K	
L	

注 Note:

1. The coil is hard magnetic, G44X0.8
2. White double-sided tape with ears on the back of the magnetic disc
3. Coil outlet position entanglement
- 8mm high temperature tape
4. Do not loosen the coil

二、原理图 (schematic diagram:)

三、绕线参数(WindingSpecification:)

序号 NO.	端子 TERMINAL	线径 WIRE	圈数 Turns	绕线方向 Winding Direction
1		0.08X105P丝包线 Silk-covered wire	10TS	逆时针 anticlockwise

四、电气特性 ELECTRICAL CHARACTERISTICS:

温度 TEMPERATURE: 25±10° C, 湿度 RELATIVE HUMIDITY: 65±20%

序号 NO.	项目 ITEM	端子 TERMINAL	标准 SPECIFICATION	测试条件 TEST FREQUENCY	测试仪器 TEST EQUIPMENTS
1	IND.		6.3UH±10%加磁片 Magnetized sheet	100KHZ/1.0V	SHDA 1062
2	IND.				
3	Q value				
4	DCR				

拟制/日期 PREPARED BY/DATE	审核/日期 CHECKED BY/DATE	客户/日期 CUSTOMER/DATE