



# 东莞市德弗力五金电子材料有限公司

Dongguan city DFL Electronic Technology Co.,LTD

## SPECIFICATION

产品型号: DESC	JYC-Y20.5*43-10-FR	版本 Rev:A	Customer:	
			Description:	A11线圈+硬磁
			Date:	20211119

### 一、尺寸DIMENSION: (mm)

A	44.0±1.0
B	20.5±1.0
C	43.0±1.5
D	10.0±2.0
E	0.8±0.2
F	3.5±1.5
G	
H	
I	
J	
K	
L	

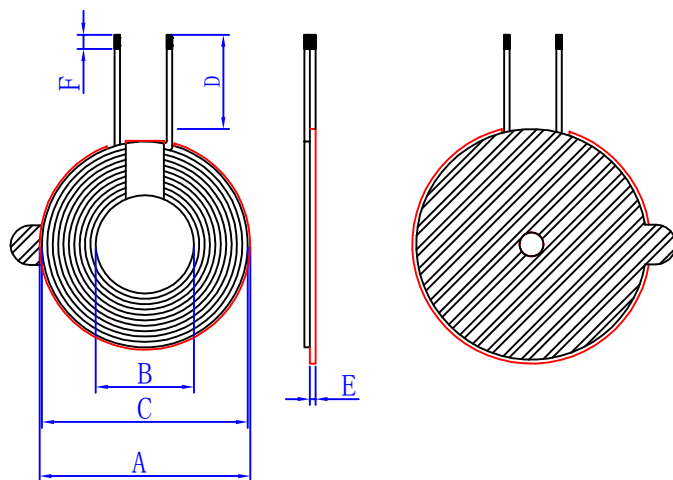

注:

1. 线圈反贴硬磁，磁片G44X0.8
2. 磁片背面贴白色带耳朵双面胶
3. 线圈出线位置缠8mm高温胶带
4. 线圈不可松线

### 二、原理图 (schematic diagram:)

### 三、绕线参数(WindingSpecification:)

序号 NO.	端子 TERMINAL	线径 WIRE	圈数 Turns	绕线方向 Winding Direction
1		0.08X105P丝包线	10TS	逆时针

### 四、电气特性 ELECTRICAL CHARACTERISTICS:

温度 TEMPERATURE: 25±10° C, 湿度 RELATIVE HUMIDITY: 65±20%

序号 NO.	项目 ITEM	端子 TERMINAL	标准 SPECIFICATION	测试条件 TEST FREQUENCY	测试仪器 TEST EQUIPMENTS
1	IND.		6.3UH±10%加磁片	100KHZ/1.0V	SHDA 1062
2	IND.				
3	Q值				
4	DCR				

拟制/日期PREPARED BY/DATE	审核/日期CHECKED BY/DATE	客户/日期CUSTOMEU/DATE