



RADIO TEST REPORT

Applicant : Elo Touch Solutions, Inc.
Address : 670 N. McCarthy Blvd., Suite 100, Milpitas,
CA 95035, USA
Equipment : Touch All-in-One Computer
Model No. : ESY22I1D
Trade Name : Elo or 
FCC ID : RBWESY22I1DNFC

I HEREBY CERTIFY THAT :

The sample was received on Mar. 01, 2024 and the testing was completed on Jun. 20, 2024 at CerpPASS Technology Corp. The test result refers exclusively to the test presented test model / sample. Without written approval of CerpPASS Technology Corp., the test report shall not be reproduced except in full.

Approved by:

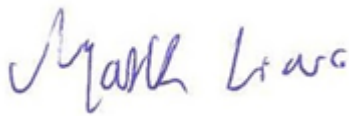

Mark Liao / Supervisor

Laboratory Accreditation:

CerpPASS Technology Corporation Test Laboratory





Contents

1. Summary of Test Procedure and Test Results	4
1.1. Applicable Standards	4
2. Test Configuration of Equipment under Test	5
2.1. Feature of Equipment under Test	5
2.2. Carrier Frequency of Channels	6
2.3. Test Mode and Test Software	6
2.4. Description of Test System	6
2.5. General Information of Test	7
2.6. Measurement Uncertainty	7
3. Test Equipment and Ancillaries Used for Tests	8
4. Antenna Requirements	9
4.1. Standard Applicable	9
4.2. Antenna Construction and Directional Gain	9
5. Test of AC Power Line Conducted Emission	10
5.1. Test Limit	10
5.2. Test Procedures	10
5.3. Typical Test Setup	11
5.4. Test Result and Data	12
5.5. Test Photographs	14
6. Test of Radiated Emission	15
6.1. Test Limit	15
6.2. Test Procedures	16
6.3. Typical Test Setup Layout of Radiated Emission	17
6.4. Test Result and Data	18
6.5. 20dB Bandwidth & 99% Occupied Bandwidth	24
6.6. Test Photographs (9KHz ~ 30MHz)	25
6.7. Test Photographs (30MHz ~ 1GHz)	26
7. Frequency Stability	27
7.1. Test Procedure	27
7.2. Test Setup Layout	27
7.3. Test Result and Data	28
8. Radio Frequency Exposure	29
8.1. Applicable Standards	29
8.2. EUT Specification	30
8.3. Test Results	30



History of this test report

Report No.	Issued Date	Description
24030030-TRFCC05	Jun. 24, 2024	Original



1. Summary of Test Procedure and Test Results

1.1. Applicable Standards

ANSI C63.10:2013

FCC Rules and Regulations Part 15 Subpart C §15.225

FCC Rule	Description of Test	Result
15.203	Antenna Requirement	PASS
15.207	AC Power Line Conducted Emission	PASS
15.209 15.225	Radiated Emission	PASS
15.225	20dB Bandwidth	PASS
15.225(e)	Frequency Stability	PASS

*The lab has reduced the uncertainty risk factor from test equipment, environment and staff technicians which according to the standard on contract. Therefore, the test result will only be determined by standard requirement, measurement uncertainty evaluation is not considered.



2. Test Configuration of Equipment under Test

2.1. Feature of Equipment under Test

Operation Frequency Range	NFC: 13.553MHz~13.567MHz BT / BLE: 2400-2483.5MHz 802.11b/g/n: 2400-2483.5MHz 802.11a/n/ac: 5150-5250MHz, 5250-5350MHz, 5470-5725MHz, 5725-5850MHz
Center Frequency Range	NFC: 13.56MHz BT / BLE: 2402MHz-2480MHz 802.11b/g/n: 2412MHz-2462MHz 802.11a/n/ac: 5180-5240MHz, 5260-5320MHz, 5500-5700MHz, 5745-5825MHz
Modulation Type	NFC: ASK BT: GFSK, $\pi/4$ -DQPSK, 8DPSK BLE: GFSK WLAN: 802.11b: CCK, DQPSK, DBPSK 802.11g/n: BPSK, QPSK, 16QAM, 64QAM 802.11a: BPSK, QPSK, 16QAM, 64QAM 802.11ac: BPSK, QPSK, 16QAM, 64QAM, 256QAM
Modulation Technology	DSSS, OFDM, FHSS, DTS
Data Rate	BT: GFSK: 1Mbps, $\pi/4$ -DQPSK: 2Mbps, 8DPSK: 3Mbps BLE: GFSK: 1Mbps WLAN: 2.4GHz: 802.11b: 1, 2, 5.5, 11Mbps 802.11g: 6, 9, 12, 18, 24, 36, 48, 54Mbps 802.11n: MCS0 – MCS15, HT20/40 5GHz: 802.11a: 6, 9, 12, 18, 24, 36, 48, 54Mbps 802.11n: MCS0 – MCS15, HT20/40 802.11ac: MCS0 – MCS9, VHT20/40/80
Antenna Type	NFC: Loop Antenna BT/BLE/2.4G/5G: Dipole Antenna
Antenna Gain	For NFC: 0dBi For BT / BLE: 2400-2480MHz: ANT A: 4.45dBi For WLAN: 2400-2500MHz: ANT A: 4.45dBi, ANT B: 2.5dBi 5150-5250MHz: ANT A: 3.79dBi, ANT B: 4.80dBi 5250-5350MHz: ANT A: 3.62dBi, ANT B: 4.98dBi 5471-5725MHz: ANT A: 2.12dBi, ANT B: 5.87dBi 5725-5850MHz: ANT A: 1.87dBi, ANT B: 5.97dBi
Adapter	Brand: DELTA Model: ADP-65JH HB
	Brand: BILLION Model: BA090-190474MBX
	Brand: BILLION Model: BA070-190342MBX
Panel	Brand: LG Model: LM215WF3



	Brand: AUO Model: M215HAN01.2
Firmware Number	22in-I-Series-4
Serial Number	SWEP_sdm660la50_v12.047.03.p_01

Note:

1. EUT support TPC Function.
2. EUT support Client Mode without radar detection.
3. EUT WLAN 2.4GHz 802.11b and 802.11g 1TX diversity
4. WLAN and BT can simultaneously transmission.
5. For more details, please refer to the User’s manual of the EUT.
6. Panel (Brand: LG, Model: LM215WF3) is worst case, hence used at test report.

2.2. Carrier Frequency of Channels

Channel	Frequency(MHz)
*1	13.56

Note: Channel remarked “*” is selected to perform test.

2.3. Test Mode and Test Software

- a. During testing, the interface cables and equipment positions were varied according to ANSI C63.10.
- b. The complete test system included EUT for RF test.
- c. Hardware control was executed to transmit and receive data via NFC.
- d. The test mode of RF test as follow:
 - Test Mode 1. TX mode, Power from Adapter (AC 120V / 60Hz)
 - Test Mode 2. TX mode, Power from Adapter (AC 240V / 60Hz)
 caused “Test Mode 2” generated the worst case, it was reported as the final data.

Note:

1. There are three types of Adapters with the shipment, After engineering evaluation, Model: ADP-65JH HB are worst case, hence, are used at test report.

2.4. Description of Test System

Frequency Stability				
Equipment	Brand	Model	Length/Type	Power cord/Length/Type
NFC Card	Tiananxin	NFC Tag Kit	N/A	N/A
Radiated Emissions				
Equipment	Brand	Model	Length/Type	Power cord/Length/Type
NFC Card	Tiananxin	NFC Tag Kit	N/A	N/A
AC Power Line Conducted Emission				
Equipment	Brand	Model	Length/Type	Power cord/Length/Type
NFC Card	Tiananxin	NFC Tag Kit	N/A	N/A



2.5. General Information of Test

☒ Test Site	CerpPASS Technology Corporation Test Laboratory Address: No.10, Ln. 2, Lianfu St., Luzhu Dist., Taoyuan City 33848, Taiwan (R.O.C.) Tel: +886-3-3226-888 Fax: +886-3-3226-881	
	FCC	TW1439, TW1079
	IC	4934E-1, 4934E-2
Frequency Range Investigated	Conducted: from 150kHz to 30 MHz Radiation: from 30 MHz to 40,000MHz	
Test Distance	The test distance of radiated emission from antenna to EUT is 3 M.	

Test Item	Test Site	Test period	Environmental Conditions	Tested By
Frequency Stability	RFCON01-NK	2024/06/20	25.1°C / 46%	Leon Huang
Radiated Emissions	3M02-NK	2024/03/20	19.3°C / 45%	Park Chen
Radiated Emissions	3M02-NK	2024/05/15	22.1°C / 36%	Leon Huang
AC Power Line Conducted Emission	CON02-NK	2024/03/21	21.7°C / 47%	Leon Huang

2.6. Measurement Uncertainty

ISO/IEC 17025 requires that an estimate of the measurement uncertainties associated with the emissions test results be included in the report. The measurement uncertainties given below are based on a 95% confidence level (based on a coverage factor (k=2))

Measurement Item	Uncertainty
Radiated Spurious Emission(9KHz~30MHz)	±3.5dB
Radiated Spurious Emission(30MHz~1GHz)	±5.1dB
20dB Bandwidth	±4.4%
Occupied Bandwidth	±4.5%
Frequency Stability	±0.23KHz



3. Test Equipment and Ancillaries Used for Tests

Test Item	Radiated Emissions				
Test Site	Semi Anechoic Room(3M02-NK)				
Instrument	Manufacturer	Model No	Serial No	Calibration Date	Valid Date
Bilog Antenna	Schwarzbeck	VULB9168	369	2024/02/19	2025/02/18
Active Loop Antenna	Schwarzbeck	FMZB 1513	414	2024/01/16	2025/01/15
Horn Antenna	EMCO	3115	31601	2023/10/18	2024/10/17
Horn Antenna	EMCO	3116	31974	2023/10/16	2024/10/15
EMI Receiver	ROHDE & SCHWARZ	ESCI	101423	2023/07/05	2024/07/04
Spectrum Analyzer	ROHDE & SCHWARZ	FSV 40-N	102151	2023/08/15	2024/08/14
Preamplifier	Agilent	8449B	3008A01954	2024/03/01	2025/02/28
Preamplifier	EMC INSTRUMENTS	EMC184045	980065	2023/10/13	2024/10/12
Preamplifier	EM Electronics corp.	EM330	60659	2024/02/17	2025/02/16
Cable-4m(9k-3G)	EMEC	RG-223	18274M	2023/07/31	2024/07/30
Cable-3in1(30M-1G)	HARBOUR INDUSTRIES	LL142	CCE1315	2024/02/23	2025/02/22
Cable-0.5m(1G-40G)	HUBER SUHNER	SUCOFLEX 104	805443/4	2024/03/05	2025/03/04
Cable-3m(1G-40G)	HUBER SUHNER	SUCOFLEX 104	805796/4	2024/03/05	2025/03/04
Cable-8m(1G-26.5G)	WOKEN	WCBA-WCA203SM	CCE1374	2024/03/05	2025/03/04
Cable-1m(1G-40G)	HUBER SUHNER	HUBER SUHNER / SF102	552450	2023/06/08	2024/06/07
Cable-3m(1G-40G)	HUBER SUHNER	HUBER SUHNER / SF102	552451	2023/06/08	2024/06/07
E3	AUDIX	v8.2014-8-6	RK-000529	NA	NA
High Pass Filter	Warison	WFIL-H3000-18000F-03	WRJ5CFWC2J1	2023/07/03	2024/07/02
Highpass Filter	WOKEN	WFIL-H7000-18000F-01	WR468FWC2B1	2023/08/18	2024/08/17

Test Item	Frequency Stability				
Test Site	RFCON01-NK				
Instrument	Manufacturer	Model No	Serial No	Calibration Date	Valid Date
EXA Signal Analyzer	KEYSIGHT	N9010A	MY54200207	2024/04/24	2025/04/23
TEMP & HUMI CHAMBER	T-MACHINE	TMJ-9712	T-12-040111	2023/08/07	2024/08/06

Test Item	AC Power Line Conducted Emission				
Test Site	CON01-NK				
Instrument	Manufacturer	Model No	Serial No	Calibration Date	Valid Date
EMI Receiver	ROHDE & SCHWARZ	ESR 7	101906	2023/05/08	2024/05/07
TWO-LINE V-NETWORK	ROHDE & SCHWARZ	ENV216	102185	2023/08/29	2024/08/28
Cable-4m(9k-3G)	EMEC	RG-223	18274M	2023/07/31	2024/07/30
E3	AUDIX	v8.2014-8-6	RK-000536	NA	NA



4. Antenna Requirements

4.1. Standard Applicable

For intentional device, according to FCC 47 CFR Section 15.203, an intentional radiator shall be designed to ensure that no antenna other than that furnished by the responsible party shall be used with the device.

And according to FCC 47 CFR Section 15.249, if transmitting antennas of directional gain greater than 6dBi are used, the power shall be reduced by the amount in dB that the directional gain of the antenna exceeds 6dBi.

4.2. Antenna Construction and Directional Gain

Antenna Type	Loop Antenna
Antenna Gain	0 dBi



5. Test of AC Power Line Conducted Emission

5.1. Test Limit

Conducted Emissions were measured from 150 kHz to 30 MHz with a bandwidth of 9 KHz, according to the methods defined in ANSI C63.10-2013. The EUT was placed on a nonmetallic stand in a shielded room 0.8 meters above the ground plane. The interface cables and equipment positioning were varied within limits of reasonable applications to determine the position produced maximum conducted emissions.

Frequency (MHz)	Quasi Peak (dB μ V)	Average (dB μ V)
0.15 – 0.5	66-56*	56-46*
0.5 – 5.0	56	46
5.0 – 30.0	60	50

*Decreases with the logarithm of the frequency.

5.2. Test Procedures

- a. The EUT was placed 0.4 meter from the conducting wall of the shielding room was kept at least 80 centimeters from any other grounded conducting surface.
- b. Connect EUT to the power mains through a line impedance stabilization network (LISN).
- c. All the support units are connecting to the other LISN.
- d. The LISN provides 50 ohm coupling impedance for the measuring instrument.
- e. The FCC states that a 50 ohm, 50 micro-Henry LISN should be used.
- f. Both sides of AC line were checked for maximum conducted interference.
- g. The frequency range from 150 kHz to 30 MHz was searched.
- h. Set the test-receiver system to Peak Detect Function and Specified Bandwidth with Maximum Hold Mode.



5.3. Typical Test Setup

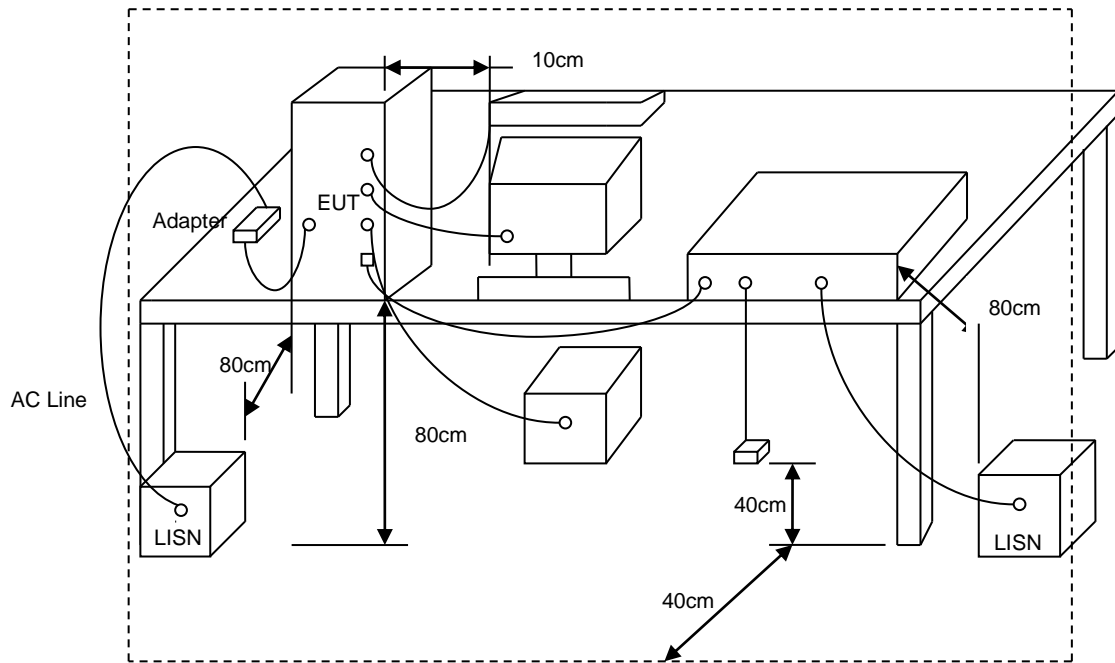



5.4. Test Result and Data

Test Mode : NFC 13.56MHz
Voltage : From Adapter(AC 240V/60Hz)
Phase : Line

Data: 82

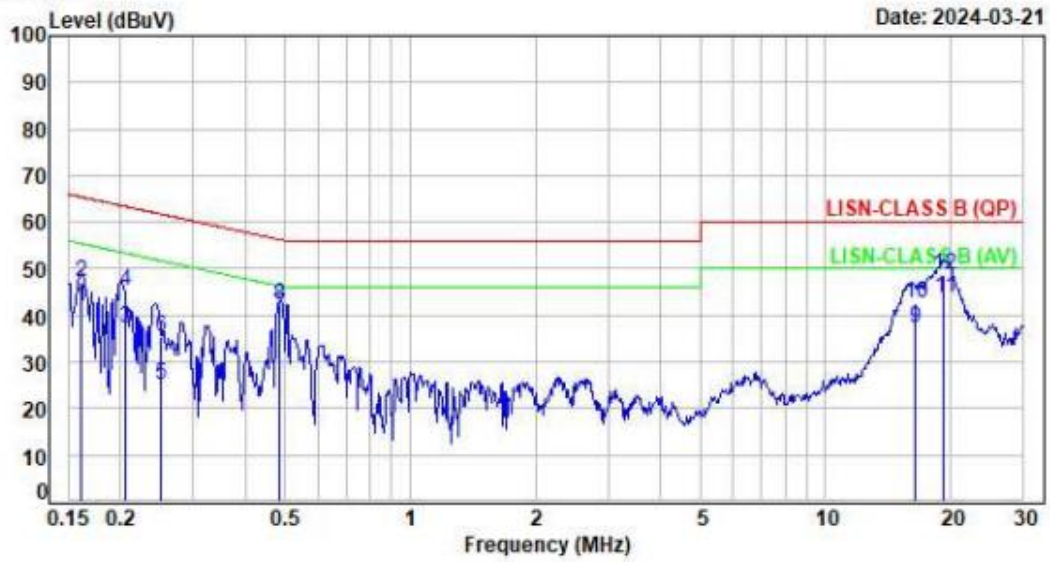

No.	Frequency (MHz)	Factor (dB)	Reading (dBuV)	Level (dBuV)	Limit (dBuV)	Margin (dB)	Detector	P/F
1	0.1615	9.65	32.17	41.82	55.39	-13.57	Average	P
2	0.1615	9.65	37.60	47.25	65.39	-18.14	QP	P
3	0.2060	9.64	27.49	37.13	53.36	-16.23	Average	P
4	0.2060	9.64	35.43	45.07	63.36	-18.29	QP	P
5	0.2499	9.64	15.45	25.09	51.76	-26.67	Average	P
6	0.2499	9.64	25.88	35.52	61.76	-26.24	QP	P
7	0.4850	9.65	30.09	39.74	46.25	-6.51	Average	P
8	0.4850	9.65	32.38	42.03	56.25	-14.22	QP	P
9	16.4507	9.92	27.31	37.23	50.00	-12.77	Average	P
10	16.4507	9.92	32.78	42.70	60.00	-17.30	QP	P
11	19.2991	9.94	33.63	43.57	50.00	-6.43	Average	P
12	19.2991	9.94	38.81	48.75	60.00	-11.25	QP	P

Note: Level=Reading+Factor
Margin=Level-Limit
Factor=(LISN or ISN or Current Probe)Factor + Cable Loss



Test Mode : NFC 13.56MHz
Voltage : From Adapter(AC 240V/60Hz)
Phase : Neutral

Data: 83

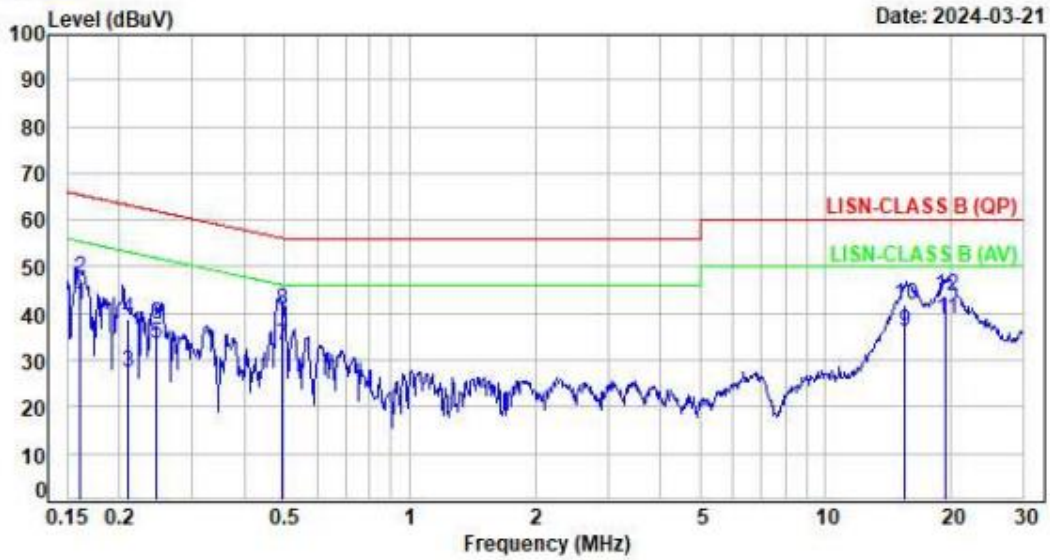

No.	Frequency (MHz)	Factor (dB)	Reading (dBuV)	Level (dBuV)	Limit (dBuV)	Margin (dB)	Detector	P/F
1	0.1605	9.57	32.22	41.79	55.44	-13.65	Average	P
2	0.1605	9.57	38.09	47.66	65.44	-17.78	QP	P
3	0.2095	9.59	17.67	27.26	53.22	-25.96	Average	P
4	0.2095	9.59	29.14	38.73	63.22	-24.49	QP	P
5	0.2463	9.58	23.72	33.30	51.88	-18.58	Average	P
6	0.2463	9.58	28.17	37.75	61.88	-24.13	QP	P
7	0.4913	9.57	23.58	33.15	46.15	-13.00	Average	P
8	0.4913	9.57	31.30	40.87	56.15	-15.28	QP	P
9	15.5154	9.91	26.08	35.99	50.00	-14.01	Average	P
10	15.5154	9.91	31.83	41.74	60.00	-18.26	QP	P
11	19.5279	9.97	28.70	38.67	50.00	-11.33	Average	P
12	19.5279	9.97	33.91	43.88	60.00	-16.12	QP	P

Note: Level=Reading+Factor
Margin=Level-Limit
Factor=(LISN or ISN or Current Probe)Factor + Cable Loss



6. Test of Radiated Emission

6.1. Test Limit

- (a) The field strength of any emissions within the band 13.553-13.567 MHz shall not exceed 15,848 microvolts/meter at 30 meters.
- (b) Within the bands 13.410-13.553 MHz and 13.567-13.710 MHz, the field strength of any emissions shall not exceed 334 microvolts/meter at 30 meters.
- (c) Within the bands 13.110-13.410 MHz and 13.710-14.010 MHz the field strength of any emissions shall not exceed 106 microvolts/meter at 30 meters.
- (d) The field strength of any emissions appearing outside of the 13.110-14.010 MHz band shall not exceed the general radiated emission limits in §15.209.

Frequency (MHz)	Distance	Limit (µV/ m)
0.09 ~ 0.490	300m	2400/F(kHz)
0.490 ~ 1.705	30m	24000/ F(kHz)
1.705 ~ 30	30m	30
30 ~ 88	3m	100
88 ~ 216	3m	150
216 ~ 960	3m	200
Above 960	3m	500

15.215 Additional provisions to the general radiated emission limitations.:

- (c) Intentional radiators operating under the alternative provisions to the general emission limits, as contained in §§15.217 through 15.257 and in subpart E of this part, must be designed to ensure that the 20 dB bandwidth of the emission, or whatever bandwidth may otherwise be specified in the specific rule section under which the equipment operates, is contained within the frequency band designated in the rule section under which the equipment is operated.



6.2. Test Procedures

- a. The EUT was placed on a rotatable table top 0.8 meter above ground.
- b. The EUT was set 3 meters from the interference receiving antenna which was mounted on the top of a variable height antenna tower.
- c. The table was rotated 360 degrees to determine the position of the highest radiation.
- d. The antenna is a broadband antenna and its height is varied between one meter and four meters above ground to find the maximum value of the field strength both horizontal polarization and vertical polarization of the antenna are set to make the measurement.
- e. For each suspected emission the EUT was arranged to its worst case and then tune the antenna tower (from 1 M to 4 M) and turn table (from 0 degree to 360 degrees) to find the maximum reading.
- f. Set the test-receiver system to Peak or CISPR quasi-peak Detect Function and specified bandwidth with Maximum Hold Mode.
- g. If the emission level of the EUT in peak mode was 3 dB lower than the limit specified, then testing will be stopped and peak values of EUT will be reported, otherwise, the emissions which do not have 3 dB margin will be repeated one by one using the quasi-peak method and reported.
- h. "Cone of radiation" has been considered to be 3dB beamwidth of the measurement antenna.

NOTE:

- 1. The resolution bandwidth of test receiver/spectrum analyzer is 300Hz or CISPS 200Hz(QP detector) at frequency Below 150 kHz.
- 2. The resolution bandwidth of test receiver/spectrum analyzer is 10KHz or CISPS 9KHz(QP detector) at frequency 150 kHz to 30 MHz.
- 3. The resolution bandwidth and video bandwidth of test receiver/spectrum analyzer is 120kHz for Peak detection (PK) and Quasi-peak detection (QP) at frequency below 1GHz.

Note: The supporting fixture shall permit orientation of the EUT in each of three orthogonal axis positions such that emissions from the EUT are maximized.



6.3. Typical Test Setup Layout of Radiated Emission

Below 30MHz test setup

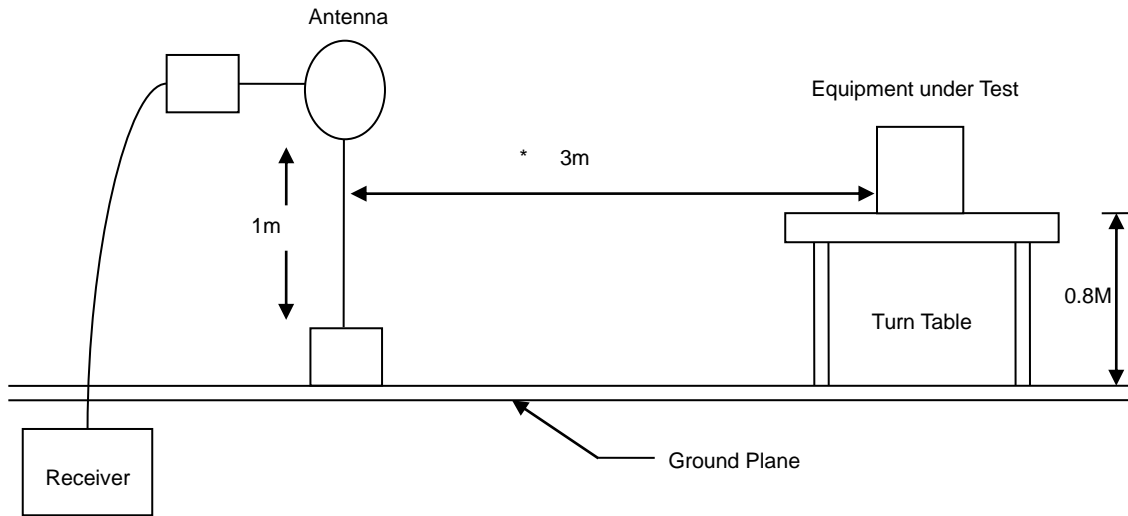

30MHz- 1GHz Test Setup

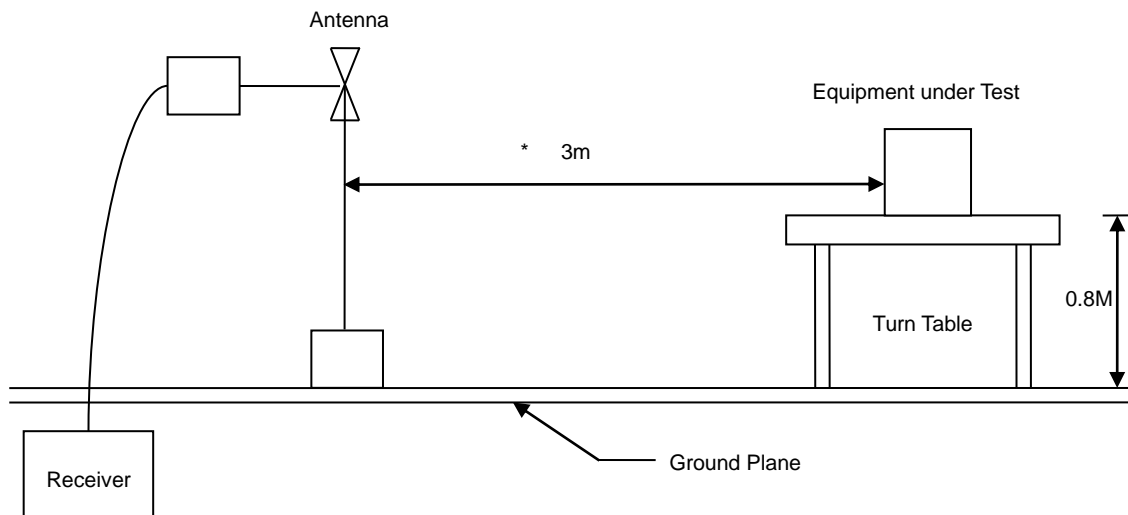



6.4. Test Result and Data

6.4.1. Test Result of Fundamental Emission

Test Mode : NFC 1TX 13.56MHz
 Voltage : From Adapter(AC120V/60Hz)
 Remark : Loop Open

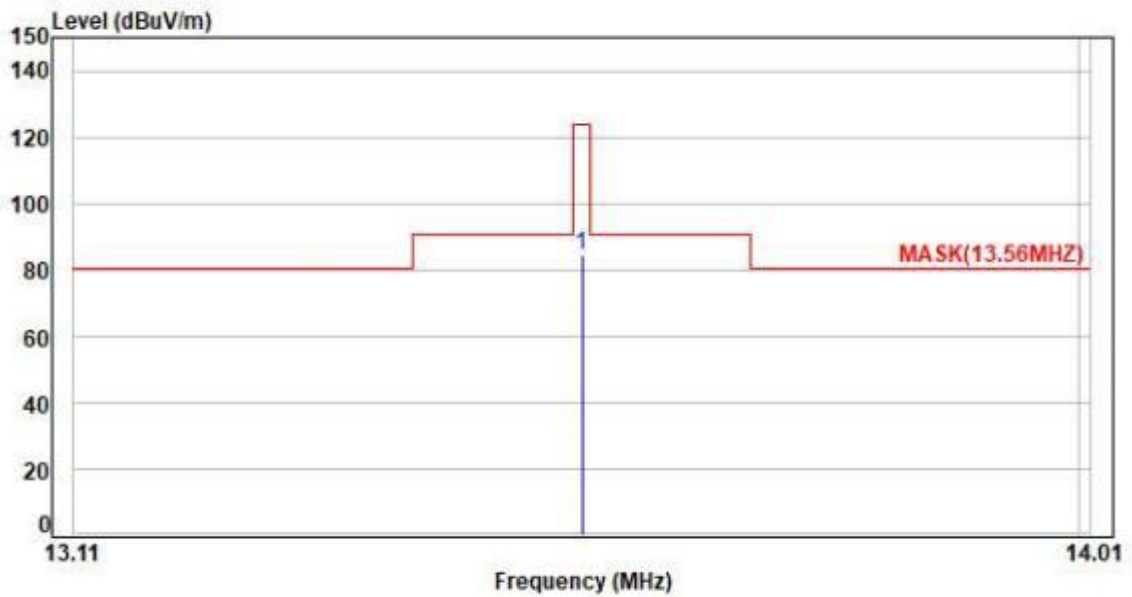

No.	Frequency (MHz)	Factor (dB)	Reading (dBuV)	Level (dBuV/m)	Limit (dBuV/m)	Margin (dB)	Detector	Height (cm)	Azimuth (deg)	P/F
1	13.560	21.168	63.130	84.298	124.000	-39.702	Peak	100	360	P

Note: Level=Reading+Factor
 Margin=Level-Limit
 Factor=Antenna Factor + cable loss - Amplifier Factor



Test Mode : NFC 1TX 13.56MHz
Voltage : From Adapter(AC120V/60Hz)
Remark : Loop Close

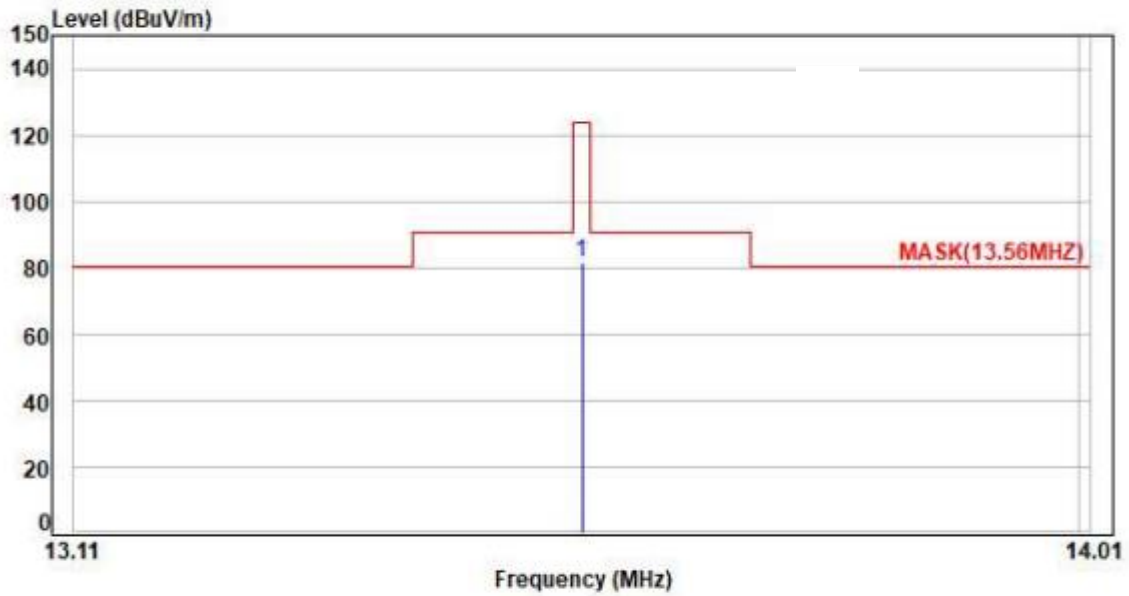

No.	Frequency (MHz)	Factor (dB)	Reading (dBuV)	Level (dBuV/m)	Limit (dBuV/m)	Margin (dB)	Detector	Height (cm)	Azimuth (deg)	P/F
1	13.560	21.168	60.430	81.598	124.000	-42.402	Peak	100	275	P

Note: Level=Reading+Factor
 Margin=Level-Limit
 Factor=Antenna Factor + cable loss - Amplifier Factor



6.4.2. Test Result of Unwanted Spurious emission (9KHz ~ 30MHz)

Test Mode : NFC 1TX 13.56MHz
Voltage : From Adapter(AC120V/60Hz)
Remark : Loop Open

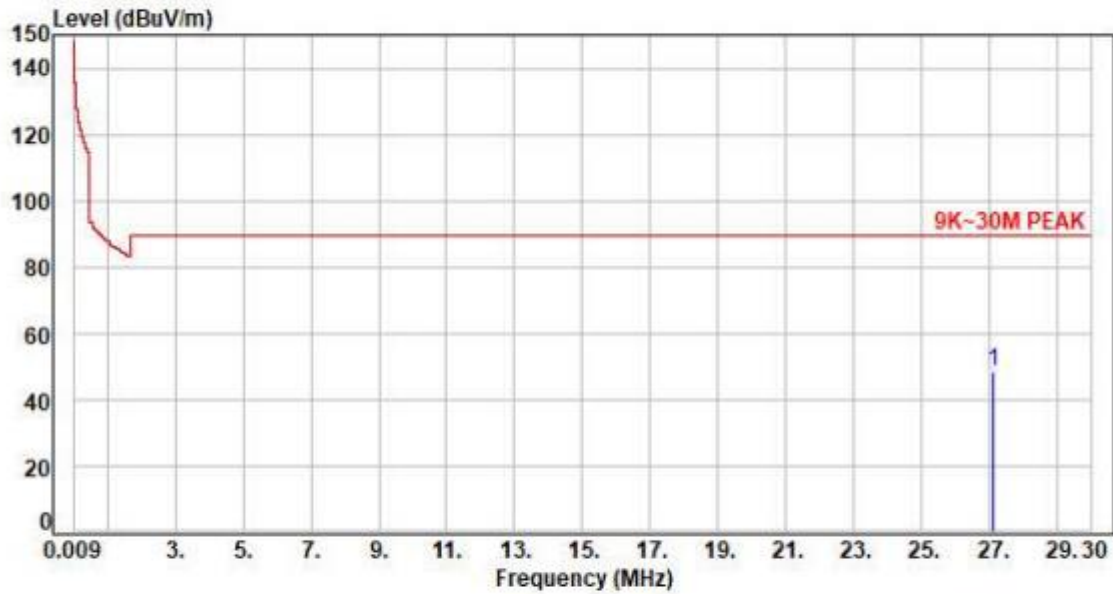
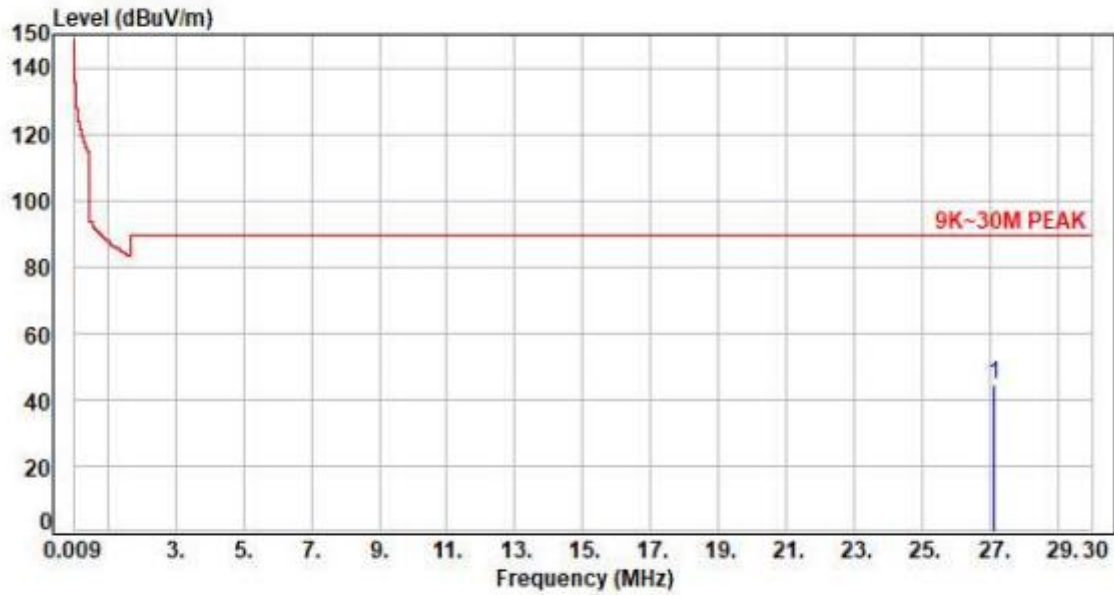

Table with 10 columns: No., Frequency (MHz), Factor (dB), Reading (dBuV), Level (dBuV/m), Limit (dBuV/m), Margin (dB), Detector, Height (cm), Azimuth P/F (deg). Row 1: 1, 27.12, 22.75, 25.62, 48.37, 89.54, -41.17, Peak, 100, 360 P

Note: Level=Reading+Factor
Margin=Level-Limit
Factor=Antenna Factor + cable loss - Amplifier Factor



Test Mode : NFC 1TX 13.56MHz
Voltage : From Adapter(AC120V/60Hz)
Remark : Loop Close



No.	Frequency (MHz)	Factor (dB)	Reading (dBuV)	Level (dBuV/m)	Limit (dBuV/m)	Margin (dB)	Detector	Height (cm)	Azimuth (deg)	P/F
1	27.12	22.75	21.88	44.63	89.54	-44.91	Peak	100	277	P

Note: Level=Reading+Factor
Margin=Level-Limit
Factor=Antenna Factor + cable loss - Amplifier Factor



6.4.3. Test Result of Unwanted Spurious emission (30GHz ~ 1GHz)

Test Mode : NFC 1TX 13.56MHz+距離1cm
Voltage : From Adapter(AC240V/60Hz)
Pol : Vertical

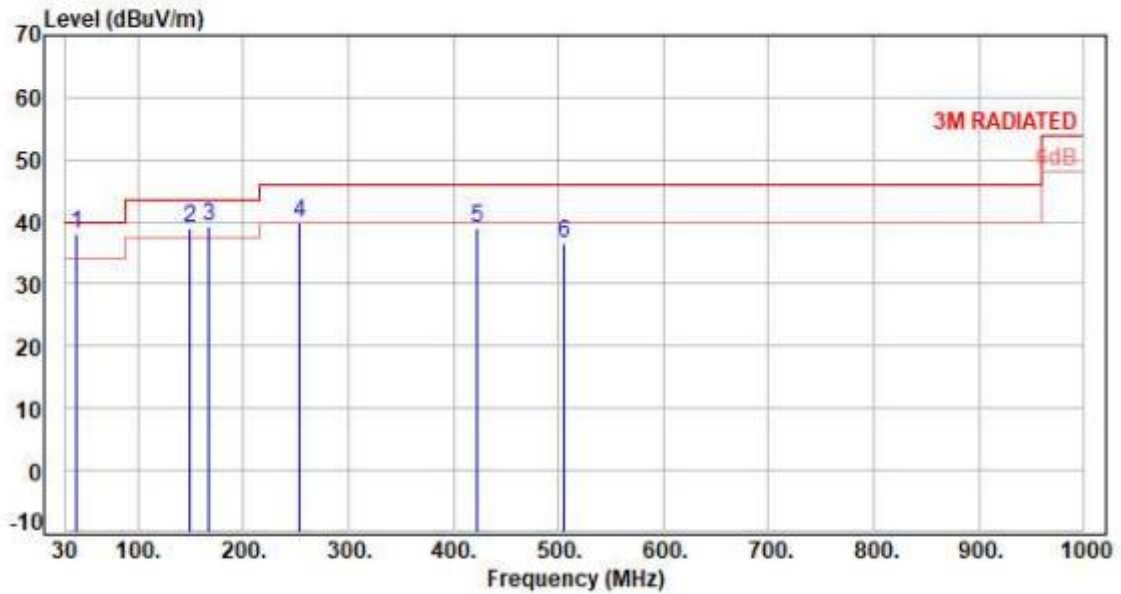
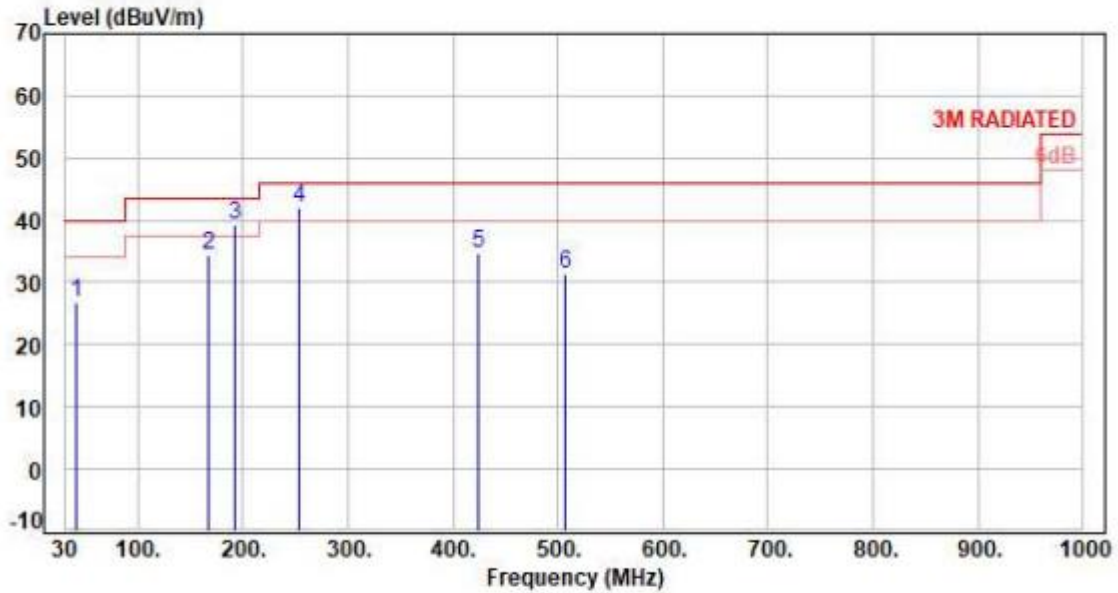

Table with 11 columns: No., Frequency (MHz), Factor (dB), Reading (dBuV), Level (dBuV/m), Limit (dBuV/m), Margin (dB), Detector, Height (cm), Azimuth (deg), P/F. Contains 6 rows of data points.

Note: Level=Reading+Factor
Margin=Level-Limit
Factor=Antenna Factor + cable loss - Amplifier Factor



Test Mode : NFC 1TX 13.56MHz+距離1cm
Voltage : From Adapter(AC240V/60Hz)
Pol : Horizontal



No.	Frequency (MHz)	Factor (dB)	Reading (dBuV)	Level (dBuV/m)	Limit (dBuV/m)	Margin (dB)	Detector	Height (cm)	Azimuth (deg)	P/F
1	40.71	-9.85	36.60	26.75	40.00	-13.25	QP	268	40	P
2	167.74	-9.55	43.85	34.30	43.50	-9.20	Peak	400	0	P
3	192.96	-11.78	50.97	39.19	43.50	-4.31	Peak	400	0	P
4	253.10	-10.04	52.01	41.97	46.00	-4.03	Peak	400	0	P
5	423.82	-5.00	39.72	34.72	46.00	-11.28	Peak	400	0	P
6	507.24	-3.18	34.68	31.50	46.00	-14.50	Peak	400	0	P

Note: Level=Reading+Factor
 Margin=Level-Limit
 Factor=Antenna Factor + cable loss - Amplifier Factor



6.5. 20dB Bandwidth & 99% Occupied Bandwidth

Modulation Mode	Freq. (MHz)	20dB Bandwidth (kHz)	F _L at 20dB BW (MHz)	F _H at 20dB BW (MHz)	99% Bandwidth (kHz)
RFID	13.56	2.7	13.56068	13.56338	2.360
Limit		N/A	13.553	13.567	N/A
Result	Pass				

20dB Bandwidth
13.56 MHz

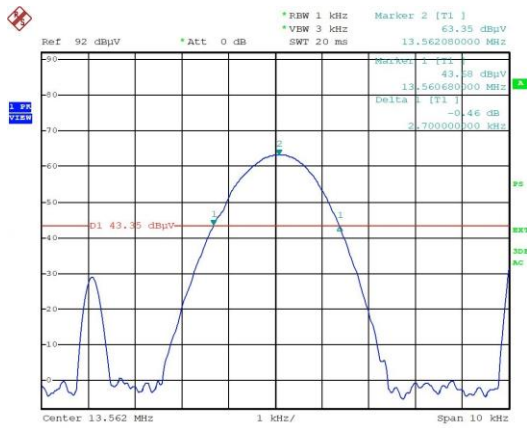

99% Bandwidth
13.56 MHz

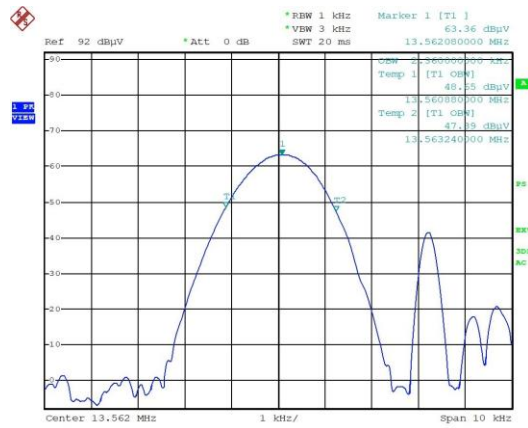



7. Frequency Stability

7.1. Test Procedure

According to the methods defined in ANSI C63.10-2013 Section 6.8

1. The EUT was placed inside the Temperature and Humidity chamber.
2. The transmitter output was connected to spectrum analyzer.
3. Turn the EUT on and couple its output to a spectrum analyzer.
4. Turn the EUT off and set the chamber to the highest temperature specified.
5. Allow sufficient time (approximately 30 min) for the temperature of the chamber to stabilize, turn the EUT on and measure the operating frequency after 2, 5, and 10 minutes.
6. Repeat step 2 and 3 with the temperature chamber set to the lowest temperature.
7. The test chamber was allowed to stabilize at +20 degree C for a minimum of 30 minutes. The supply voltage was then adjusted on the EUT from 85% to 115% and the frequency record.

7.2. Test Setup Layout

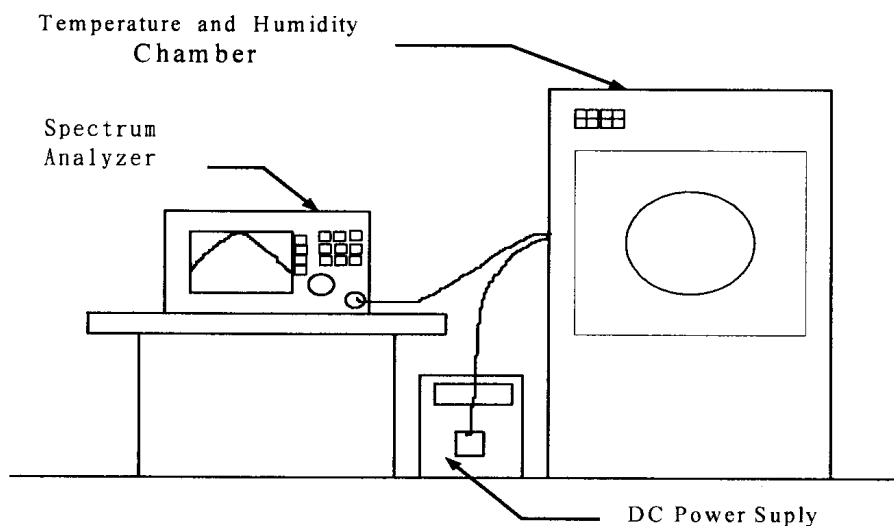



7.3. Test Result and Data

Operating frequency: 13.56MHz

Temp (°C)	Power supply (V)	0 minute		2 minute		5 minute		10 minute	
		(MHz)	(%)	(MHz)	(%)	(MHz)	(%)	(MHz)	(%)
50	102	13.5602	0.001475	13.5605	0.003687	13.5605	0.003687	13.5606	0.004425
	120	13.5605	0.003687	13.5606	0.004425	13.5605	0.003687	13.5607	0.005162
	138	13.5606	0.004425	13.5605	0.003687	13.5607	0.005162	13.5610	0.007375
40	102	13.5601	0.000737	13.5602	0.001475	13.5604	0.002950	13.5601	0.000737
	120	13.5604	0.002950	13.5604	0.002950	13.5605	0.003687	13.5610	0.007375
	138	13.5603	0.002212	13.5611	0.008112	13.5608	0.005900	13.5609	0.006637
30	102	13.5604	0.002950	13.5603	0.002212	13.5606	0.004425	13.5606	0.004425
	120	13.5603	0.002212	13.5604	0.002950	13.5605	0.003687	13.5604	0.002950
	138	13.5605	0.003687	13.5603	0.002212	13.5604	0.002950	13.5606	0.004425
20	102	13.5610	0.007375	13.5609	0.006637	13.5608	0.005900	13.5608	0.005900
	120	13.5607	0.005162	13.5606	0.004425	13.5608	0.005900	13.5607	0.005162
	138	13.5608	0.005900	13.5607	0.005162	13.5606	0.004425	13.5608	0.005900
10	102	13.5609	0.006637	13.5609	0.006637	13.5610	0.007375	13.5609	0.006637
	120	13.5611	0.008112	13.5607	0.005162	13.5609	0.006637	13.5608	0.005900
	138	13.5608	0.005900	13.5608	0.005900	13.5610	0.007375	13.5608	0.005900
0	102	13.5609	0.006637	13.5609	0.006637	13.5606	0.004425	13.5608	0.005900
	120	13.5608	0.005900	13.5608	0.005900	13.5607	0.005162	13.5609	0.006637
	138	13.5611	0.008112	13.5610	0.007375	13.5608	0.005900	13.5610	0.007375
-10	102	13.5608	0.005900	13.5609	0.006637	13.5609	0.006637	13.5611	0.008112
	120	13.5609	0.006637	13.5612	0.008850	13.5609	0.006637	13.5608	0.005900
	138	13.5610	0.007375	13.5608	0.005900	13.5608	0.005900	13.5609	0.006637
-20	102	13.5609	0.006637	13.5609	0.006637	13.5610	0.007375	13.5610	0.007375
	120	13.5608	0.005900	13.5610	0.007375	13.5608	0.005900	13.5611	0.008112
	138	13.5608	0.005900	13.5608	0.005900	13.5610	0.007375	13.5609	0.006637
-30	102	13.5609	0.006637	13.5607	0.005162	13.5609	0.006637	13.5611	0.008112
	120	13.5610	0.007375	13.5609	0.006637	13.5611	0.008112	13.5608	0.005900
	138	13.5608	0.005900	13.5610	0.007375	13.5610	0.007375	13.5608	0.005900