



FCC RADIO TEST REPORT

Applicant : ELO TOUCH SOLUTIONS, INC.
Address : 670 N. McCarthy Blvd., Suite 100 Milpitas, CA 95035
: USA
Equipment : Touch All-in-One Computer
Model No. : ESY15I1E-C
Trade Name : Elo or 
FCC ID : RBWESY15I1EC

I HEREBY CERTIFY THAT :

The sample was received on Jun. 27, 2024 and the testing was completed on Oct. 14, 2024 at CerpPASS Technology Corp. The test result refers exclusively to the test presented test model / sample. Without written approval of CerpPASS Technology Corp., the test report shall not be reproduced except in full.

Approved by:

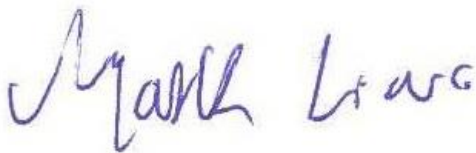

Mark Liao / Supervisor

Laboratory Accreditation:

CerpPASS Technology Corporation Test Laboratory





Contents

1. Summary of Test Procedure and Test Results	5
1.1 Applicable Standards	5
2. Test Configuration of Equipment under Test	6
2.1 Feature of Equipment under Test	6
2.2 Carrier Frequency of Channels	8
2.3 Test Mode and Test Software	9
2.4 Description of Test System	11
2.5 General Information of Test	12
2.6 Measurement Uncertainty	13
3. Test Equipment and Ancillaries Used for Tests	14
4. Antenna Requirements	16
4.1 Standard Applicable	16
4.2 Antenna Construction and Directional Gain	16
5. Test of AC Power Line Conducted Emission	17
5.1 Test Limit	17
5.2 Test Procedures	17
5.3 Typical Test Setup	18
5.4 Test Result and Data	19
5.5 Test Photographs	21
6. Test of Radiated Spurious Emission	22
6.1 Test Limit	22
6.2 Test Procedures	23
6.3 Typical Test Setup	24
6.4 Test Result and Data (9KHz ~ 30MHz)	26
6.5 Test Result and Data (30MHz ~ 1GHz)	26
6.6 Test Result and Data (1GHz ~ 25GHz)	28
6.7 Restricted Bands of Operation	64
6.8 Test Photographs (30MHz ~ 1GHz)	65
6.9 Test Photographs (1GHz ~ 25GHz)	66
7. Test of Conducted Spurious Emission	68
7.1 Test Limit	68
7.2 Test Procedure	68
7.3 Test Setup Layout	68
7.4 Test Result and Data	68
8. On Time, Duty Cycle and Measurement methods	79
8.1 Test Limit	79
8.2 Test Procedure	79
8.3 Test Setup Layout	79
8.4 Test Result and Data	79
9. 6dB Bandwidth Measurement Data	81
9.1 Test Limit	81
9.2 Test Procedures	81



9.3 Test Setup Layout 81

9.4 Test Result and Data 82

10. Maximum Average Output Power 87

10.1 Test Limit 87

10.2 Test Procedures 87

10.3 Test Setup Layout 87

10.4 Test Result and Data 88

11. Power Spectral Density 90

11.1 Test Limit 90

11.2 Test Procedures 90

11.3 Test Setup Layout 90

11.4 Test Result and Data 91

12. Radio Frequency Exposure 96

12.1 Applicable Standards 96

12.2 EUT Specification 97

12.3 Result 98



1. Summary of Test Procedure and Test Results

1.1 Applicable Standards

ANSI C63.10:2013

FCC Rules and Regulations Part 15 Subpart C §15.247

FCC Rule	Description of Test	Result
15.203	. Antenna Requirement	PASS
15.207	. AC Power Line Conducted Emission	PASS
15.209 15.205	. Radiated Spurious Emission	PASS
15.247(d)	. Conducted Spurious Emission	PASS
15.247(a)(2)	. 6dB Bandwidth	PASS
15.247(b)	. Output Power	PASS
15.247(e)	. Power Spectral Density	PASS
2.1091	. Radio Frequency Exposure	PASS

*The lab has reduced the uncertainty risk factor from test equipment, environment and staff technicians which according to the standard on contract. Therefore, the test result will only be determined by standard requirement, measurement uncertainty evaluation is not considered.



2. Test Configuration of Equipment under Test

2.1 Feature of Equipment under Test

Operation Frequency Range	BT / BLE: 2400-2483.5MHz WLAN:802.11b/g/n/ax: 2400-2483.5MHz 5GHz:802.11a/n/ac/ax:5150-5250MHz, 5250-5350MHz, 5470-5725MHz, 5725-5875MHz 6GHz: 802.11a/ax: 5925MHz~6425MHz, 6425MHz~6525MHz 6525MHz~6875MHz, 6875MHz~7125MHz
Center Frequency Range	BT / BLE: 2402MHz-2480MHz WLAN:802.11b/g/n/ax: 2412MHz-2462MHz 5GHz:802.11a/n/ac/ax:5180-5240MHz, 5260-5320MHz, 5500-5720MHz, 5745-5825MHz 6GHz: 802.11a/ax: 5955MHz~6415MHz, 6435MHz~6515MHz 6535MHz~6855MHz, 6875MHz~7115MHz
Modulation Type	BT: GFSK, $\pi/4$ -DQPSK, 8DPSK BLE: GFSK WLAN: 2.4GHz: 802.11b: CCK, DQPSK, DBPSK 802.11g/n: BPSK, QPSK, 16QAM, 64QAM 802.11ax: BPSK, QPSK, 16QAM, 64QAM, 256QAM, 1024QAM 5GHz: 802.11a/n: BPSK, QPSK, 16QAM, 64QAM 802.11ac: BPSK, QPSK, 16QAM, 64QAM, 256QAM 802.11ax: BPSK, QPSK, 16QAM, 64QAM, 256QAM, 1024QAM 6GHz 802.11a: BPSK, QPSK, 16QAM, 64QAM 802.11ax: BPSK, QPSK, 16QAM, 64QAM, 256QAM, 1024QAM
Modulation Technology	DSSS, OFDM, FHSS, DTS, OFDMA
Data Rate	BT: GFSK: 1Mbps, $\pi/4$ -DQPSK: 2Mbps, 8DPSK: 3Mbps BLE: GFSK: 1Mbps, 2Mbps WLAN: 2.4GHz: 802.11b: 1, 2, 5.5, 11Mbps 802.11g: 6, 9, 12, 18, 24, 36, 48, 54Mbps 802.11n: MCS0 – MCS15, HT20/40 802.11ax: MCS0 – MCS11, HE20/40 5GHz: 802.11a: 6, 9, 12, 18, 24, 36, 48, 54Mbps 802.11n: MCS0 – MCS15, HT20/40 802.11ac: MCS0 – MCS9, VHT20/40/80/160 802.11ax: MCS0 – MCS11, HE20/40/80/160 6GHz 802.11a: 6, 9, 12, 18, 24, 36, 48, 54Mbps 802.11ax: MCS0 – MCS11, HE20/40/80/160
Antenna Type	PIFA Antenna



Antenna Gain	For BT / BLE: 2400-2500MHz: ANT A: 1.97dBi For WLAN: 2400-2500MHz: ANT A: 1.97dBi, ANT B: 1.82dBi 5150-5250MHz: ANT A: 2.73dBi, ANT B: 2.11dBi 5250-5350MHz: ANT A: 2.73dBi, ANT B: 2.54dBi 5470-5725MHz: ANT A: 2.35dBi, ANT B: 2.4dBi 5725-5850MHz: ANT A: 2.4dBi, ANT B: 2.34dBi 5925~6425MHz:ANT A: 2.07dBi, ANT B: 2.48dBi 6425~6525MHz:ANT A: 1.77dBi, ANT B: 1.79dBi 6525~6875MHz:ANT A: 2.43dBi, ANT B: 2.37dBi 6875~7125MHz:ANT A: 2.24dBi, ANT B: 2.19dBi
Adapter	Brand: Delta Model: ADP-150EH B
Adapter	Brand: Delta Model: ADP-65JH HB
Adapter	Brand: Billion Model: BA070-190342MBX
Adapter	Brand: FSP Model: FSP150-AABN3
Power cord (US)	Brand: I-SHENG Model: V44VS336T1218000-A01
Power cord (EU)	Brand: I-SHENG Model: EU85B300S121800
USBC-POS-STAND	Brand: ELO Model: KIT, Z30-POS-Stand-CFD-Gen 2-15
USBC-POS-STAND	Brand: ELO Model: KIT, Z30-POS-STAND-GEN2-15
USBC-IO-HUB	Brand: ELO Model: USBC-IO-HUB-POWER-BARICK-V2
Panel	Brand: AUO Model: A156HAN01.1
Panel	Brand: BOE Model: PV156FHM-N30

Note:

1. EUT support TPC Function.
2. EUT supports DFS Client Mode, without radar detection.
3. WLAN and BT can simultaneously transmission.
4. The device not support Channel Puncturing or Bandwidth Reduction mechanisms supported
5. 802.11ax EUT only Support Full RU
6. EUT Operating mode: Indoor Client.
7. For more details, please refer to the User’s manual of the EUT.



2.2 Carrier Frequency of Channels

802.11b, 802.11g, 802.11n HT20, 802.11ax HE20 (2412MHz-2462MHz)

Channel	Frequency(MHz)	Channel	Frequency(MHz)
*01	2412	07	2442
02	2417	08	2447
03	2422	09	2452
04	2427	10	2457
05	2432	*11	2462
*06	2437	---	---

802.11n HT40, 802.11ax HE40 (2422MHz-2452MHz)

Channel	Frequency(MHz)	Channel	Frequency(MHz)
---	---	07	2442
---	---	08	2447
*03	2422	*09	2452
04	2427	---	---
05	2432	---	---
*06	2437	---	---

Note: Channels remarked * are selected to perform test.



2.3 Test Mode and Test Software

- a. During testing, the interface cables and equipment positions were varied according to ANSI C63.10.
- b. The complete test system included remote workstation and EUT for RF test. The remote workstation included Notebook.
- c. An executive program, " QRCT V4.0.211.0" under Windows OS system was executed to transmit and receive data via WLAN.
- d. The following test modes were performed for the test:

Conducted Emissions from the AC mains power ports	
Test Mode	Operating Description
1	802.11b (1Mbps), From Adapter
2	802.11g (6Mbps), From Adapter
3	802.11ax HE20 (7.3Mbps), From Adapter
4	802.11ax HE40 (14.6Mbps), From Adapter
caused "Test Mode 3" generated the worst case, it was reported as the final data.	
Radiation Emissions (9KHz ~30MHz & 30MHz ~ 1GHz)	
Test Mode	Operating Description
1	802.11b (1Mbps), Power from Adapter
2	802.11g (6Mbps), Power from Adapter
3	802.11ax HE20 (7.3Mbps), From Adapter
4	802.11ax HE40 (14.6Mbps), From Adapter
caused "Test Mode 3" generated the worst case, they were reported as the final data.	
Radiation Emissions (1GHz ~ 25GHz)	
Test Mode	Operating Description
1	802.11b (1Mbps), Power from Adapter
2	802.11g (6Mbps), Power from Adapter
3	802.11ax HE20 (7.3Mbps), From Adapter
4	802.11ax HE40 (14.6Mbps), From Adapter
caused "Test Mode 1~4" generated the worst case, they were reported as the final data.	

Note:1. There are two kinds of test voltage: AC 120V / 60Hz and AC 240V / 60Hz.
worst case (V)

Test Item /test voltage	AC 120V / 60Hz	AC 240V / 60Hz.
AC Power Line Conducted Emission: SISO ANT/ MIMO ANT	V	
Radiation Emissions (Below 1GHz) : SISO ANT/ MIMO ANT		V

2.The EUT has Four types of Adapters. After engineering evaluation,
For AC Power Line Conducted Emission, FSP150-AABN3 is worst case.
For Radiated Spurious Emission(9kHz~30MHz,30MHz~1GHz), ADP-65JH is worst case.
For Radiated Spurious Emission(1GHz~40GHz), ADP-150EH B is worst case., hence, are used at test report.

Adapter	Brand: Delta Model: ADP-150EH B
Adapter	Brand: Delta Model: ADP-65JH HB
Adapter	Brand: Billion Model: BA070-190342MBX
Adapter	Brand: FSP Model: FSP150-AABN3



3. There are two types of Panels: AUO&BOE. After engineering evaluation, AUO is worst case, hence, is used at test report.

Panel	Brand: AUO Model: A156HAN01.1
	Brand: BOE Model: PV156FHM-N30

4. The EUT has Two types of USBC-POS-STANDS. After engineering evaluation, For AC Power Line Conducted Emission, KIT, Z30-POS-STAND-GEN2-15 is worst case. For Radiated Spurious Emission(9kHz~30MHz,30MHz~1GHz), none-docking is worst case. For Radiated Spurious Emission(1GHz~40GHz), KIT, Z30-POS-STAND-CFD-Gen 2-15 is worst case., hence, are used at test report

USBC-POS-STAND	Brand: ELO Model: KIT, Z30-POS-Stand-CFD-Gen 2-15
USBC-POS-STAND	Brand: ELO Model: KIT, Z30-POS-STAND-GEN2-15

The EUT incorporates a MIMO function

Modulation Type	TX CONFIGURATION
802.11b	1TX(Diversity)
802.11g	1TX(Diversity)
802.11n HT20	2TX
802.11n HT40	2TX
802.11ax HE20	2TX
802.11ax HE40	2TX



2.4 Description of Test System

RF Conducted				
Equipment	Brand	Model	Length/Type	Power cord/Length/Type
Notebook	DELL	Latitude E5470	N/A	Adapter / 1.8m / NS
USB Cable	BENEVO	BUSB3100AMF	1m / NS	N/A
Adapter	APD	WB-18D12R	1.8m / NS	N/A
Radiated Emissions				
Equipment	Brand	Model	Length/Type	Power cord/Length/Type
Notebook	DELL	Latitude E5470	N/A	Adapter / 1.8m / NS
USB Cable	BENEVO	BUSB3100AMF	1m / NS	N/A
Adapter	APD	WB-18D12R	1.8m / NS	N/A
AC Power Line Conducted Emission				
Equipment	Brand	Model	Length/Type	Power cord/Length/Type
Notebook	DELL	Latitude E5470	N/A	Adapter / 1.8m / NS
USB Cable	BENEVO	BUSB3100AMF	1m / NS	N/A
Adapter	APD	WB-18D12R	1.8m / NS	N/A



2.5 General Information of Test

☑ Test Site	CerpPASS Technology Corporation Test Laboratory Address: No.10, Ln. 2, Lianfu St., Luzhu Dist., Taoyuan City 33848, Taiwan (R.O.C.) Tel: +886-3-3226-888 Fax: +886-3-3226-881	
	FCC	TW1439, TW1079
	IC	4934E-1, 4934E-2
Frequency Range Investigated	Conducted: from 150kHz to 30 MHz Radiation: from 9kHz to 25,000MHz	
Test Distance	The test distance of radiated emission from antenna to EUT is 3 M.	

ANT A

Test Item	Test Site	Test Period	Environmental Conditions	Tested By
RF Conducted	RFCON01-NK	2024/08/02	25.8°C / 48%	Leon Huang

ANT B

Test Item	Test Site	Test Period	Environmental Conditions	Tested By
RF Conducted	RFCON01-NK	2024/07/29	25.2°C / 55%	Leon Huang
RF Conducted	RFCON01-NK	2024/08/01	26.9°C / 47%	Leon Huang
RF Conducted	RFCON01-NK	2024/08/02	25.8°C / 48%	Leon Huang
Radiated Emissions	3M02-NK	2024/07/23	26.4°C / 62%	Leon Huang
Radiated Emissions	3M02-NK	2024/08/20	20.4°C / 40%	Leon Huang
AC Power Line Conducted Emission	CON02-NK	2024/08/23	25.3°C / 53%	Leon Huang
AC Power Line Conducted Emission	CON02-NK	2024/08/24	26.5°C / 43%	Leon Huang

ANT A, B

Test Item	Test Site	Test Period	Environmental Conditions	Tested By
RF Conducted	RFCON01-NK	2024/07/28	26°C / 51%	Leon Huang
RF Conducted	RFCON01-NK	2024/07/29	25.2°C / 55%	Leon Huang
RF Conducted	RFCON01-NK	2024/08/01	26.9°C / 47%	Leon Huang
RF Conducted	RFCON01-NK	2024/08/02	25.8°C / 48%	Leon Huang
RF Conducted	RFCON01-NK	2024/09/30	27.8°C / 51%	Leon Huang
RF Conducted	RFCON01-NK	2024/10/14	27.9°C / 45%	Leon Huang
Radiated Emissions	3M02-NK	2024/07/23	26.4°C / 62%	Leon Huang
Radiated Emissions	3M02-NK	2024/08/20	20.4°C / 40%	Leon Huang
AC Power Line Conducted Emission	CON02-NK	2024/08/23	25.3°C / 53%	Leon Huang
AC Power Line Conducted Emission	CON02-NK	2024/08/24	26.5°C / 43%	Leon Huang



2.6 Measurement Uncertainty

ISO/IEC 17025 requires that an estimate of the measurement uncertainties associated with the emissions test results be included in the report. The measurement uncertainties given below are based on a 95% confidence level (based on a coverage factor (k=2))

Measurement Item	Uncertainty
AC Power Line Conduction(150K~30MHz)	±3.12dB
Radiated Spurious Emission(9KHz~30MHz)	±3.5dB
Radiated Spurious Emission(30MHz~1GHz)	±5.1dB
Radiated Spurious Emission(1GHz~40GHz)	±5.2dB
Conducted Spurious Emission	±2.1dB
6dB Bandwidth	±5.4%
20dB Bandwidth	±4.4%
Occupied Bandwidth	±4.5%
Peak Output Power(Conducted Power Meter)	±1.1dB
Dwell Time / Deactivation Time	±7.6%
Power Spectral Density	±2.0dB
Duty Cycle	±3.5%



3. Test Equipment and Ancillaries Used for Tests

Test Item	Radiated Emissions				
Test Site	Semi Anechoic Room(3M02-NK)				
Instrument	Manufacturer	Model No	Serial No	Calibration Date	Valid Date
Bilog Antenna	Schwarzbeck	VULB9168	369	2024/02/19	2025/02/18
Active Loop Antenna	Schwarzbeck	FMZB 1513	414	2024/01/16	2025/01/15
Horn Antenna	EMCO	3115	31589	2024/02/26	2025/02/25
Horn Antenna	EMCO	3116	31974	2023/10/16	2024/10/15
EMI Receiver	ROHDE & SCHWARZ	ESR 7	101906	2024/05/13	2025/05/12
Spectrum Analyzer	ROHDE & SCHWARZ	FSV 40-N	101329	2024/07/16	2025/07/15
Preamplifier	Agilent	8449B	3008A01954	2024/03/01	2025/02/28
Preamplifier	EMC INSTRUMENTS	EMC184045	980065	2023/10/13	2024/10/12
Preamplifier	EM Electronics corp.	EM330	60659	2024/02/17	2025/02/16
Cable-6m(9k~300M)	N/A	EMC5D-BM-BM-6	130606	2024/03/13	2025/03/12
Cable-3in1(30M-1G)	HARBOUR INDUSTRIES	LL142	CCE1315	2024/02/23	2025/02/22
Cable-0.5m(1G-40G)	HUBER SUHNER	SUCOFLEX 104	805443/4	2024/03/05	2025/03/04
Cable-3m(1G-40G)	HUBER SUHNER	SUCOFLEX 104	805796/4	2024/03/05	2025/03/04
Cable-8m(1G-26.5G)	WOKEN	WCBA-WCA203SM	CCE1374	2024/03/05	2025/03/04
Cable-1m(1G-40G)	HUBER SUHNER	HUBER SUHNER / SF102	804398/2	2023/10/12	2024/10/11
Cable-3m(1G-40G)	HUBER SUHNER	HUBER SUHNER / SF102	804619/2	2023/10/12	2024/10/11
E3	AUDIX	v8.2014-8-6	RK-000529	NA	NA
Highpass Filter	Warison	WFIL-H3000-18000F-03	WRJ5CFWC 2J1	2024/07/03	2025/07/02
Notch Filter	Warison	WFIL-N5925-7125F-04	WRQ4BFW C4M1	2024/03/11	2025/03/10
Hipass Filter	Warison	WFIL-H7500-18000F	WRQ4BFW C2J1	2024/03/11	2025/03/10

Test Item	RF Conducted				
Test Site	RFCON01-NK				
Instrument	Manufacturer	Model No	Serial No	Calibration Date	Valid Date
CAX Signal Analyzer	KEYSIGHT	N9000B	MY57100339	2023/11/06	2024/11/05
Power Meter	Anritsu	ML2495A	1224005	2024/02/17	2025/02/16
Power Sensor	Anritsu	MA2411B	1207295	2024/02/17	2025/02/16
Attenuator	KEYSIGHT	8491B	MY39250703	2024/02/20	2025/02/19



Test Item	AC Power Line Conducted Emission				
Test Site	CON02-NK				
Instrument	Manufacturer	Model No	Serial No	Calibration Date	Valid Date
EMI Receiver	ROHDE & SCHWARZ	ESR 7	101906	2024/05/13	2025/05/12
Line Impedance Stabilization Network	Schwarzbeck	NSLK 8127	8127516	2023/10/03	2024/10/02
Line Impedance Stabilization Network	Schwarzbeck	NSLK 8127	8127740	2023/08/28	2024/08/27
Pulse Limiter	ROHDE & SCHWARZ	ESH3-Z2	101934	2024/03/01	2025/02/28
Cable-6m(9k~300M)	N/A	EMC5D-BM-BM-6	130606	2024/03/13	2025/03/12
E3	AUDIX	v8.2014-8-6	RK-000536	NA	NA



4. Antenna Requirements

4.1 Standard Applicable

For intentional device, according to FCC 47 CFR Section 15.203, an intentional radiator shall be designed to ensure that no antenna other than that furnished by the responsible party shall be used with the device.

And according to FCC 47 CFR Section 15.247 (b), if transmitting antennas of directional gain greater than 6dBi are used, the power shall be reduced by the amount in dB that the directional gain of the antenna exceeds 6dBi.

4.2 Antenna Construction and Directional Gain

Antenna Type	PIFA Antenna
Antenna Gain	2400-2500MHz: ANT A: 1.97dBi, ANT B: 1.82dBi

(Non-Beamforming)

SISO ANT A

2400-2500MHz

For Power directional gain= G_{ant} = 1.97 dBi

For PSD directional gain = G_{ant} = 1.97 dBi

SISO ANT B

2400-2500MHz

For Power directional gain= G_{ant} = 1.82 dBi

For PSD directional gain = G_{ant} = 1.82 dBi

MIMO

2400-2500MHz

For Power directional gain= G_{ant} = 1.97 dBi

For PSD directional gain = $10 \log[(10^{G1/20} + 10^{G2/20} + \dots + 10^{GN/20})^2 / N_{ANT}]$
= 4.91 (dBi)

*MIMO type: Cyclic Delay Diversity (CDD) mode.



5. Test of AC Power Line Conducted Emission

5.1 Test Limit

Conducted Emissions were measured from 150 kHz to 30 MHz with a bandwidth of 9 KHz, according to the methods defined in ANSI C63.10-2013. The EUT was placed on a nonmetallic stand in a shielded room 0.8 meters above the ground plane. The interface cables and equipment positioning were varied within limits of reasonable applications to determine the position produced maximum conducted emissions.

Frequency (MHz)	Quasi Peak (dB μ V)	Average (dB μ V)
0.15 – 0.5	66-56*	56-46*
0.5 – 5.0	56	46
5.0 – 30.0	60	50

*Decreases with the logarithm of the frequency.

5.2 Test Procedures

- a. The EUT was placed 0.4 meter from the conducting wall of the shielding room was kept at least 80 centimeters from any other grounded conducting surface.
- b. Connect EUT to the power mains through a line impedance stabilization network (LISN).
- c. All the support units are connecting to the other LISN.
- d. The LISN provides 50 ohm coupling impedance for the measuring instrument.
- e. The FCC states that a 50 ohm, 50 micro-Henry LISN should be used.
- f. Both sides of AC line were checked for maximum conducted interference.
- g. The frequency range from 150 kHz to 30 MHz was searched.
- h. Set the test-receiver system to Peak Detect Function and Specified Bandwidth with Maximum Hold Mode.



5.3 Typical Test Setup

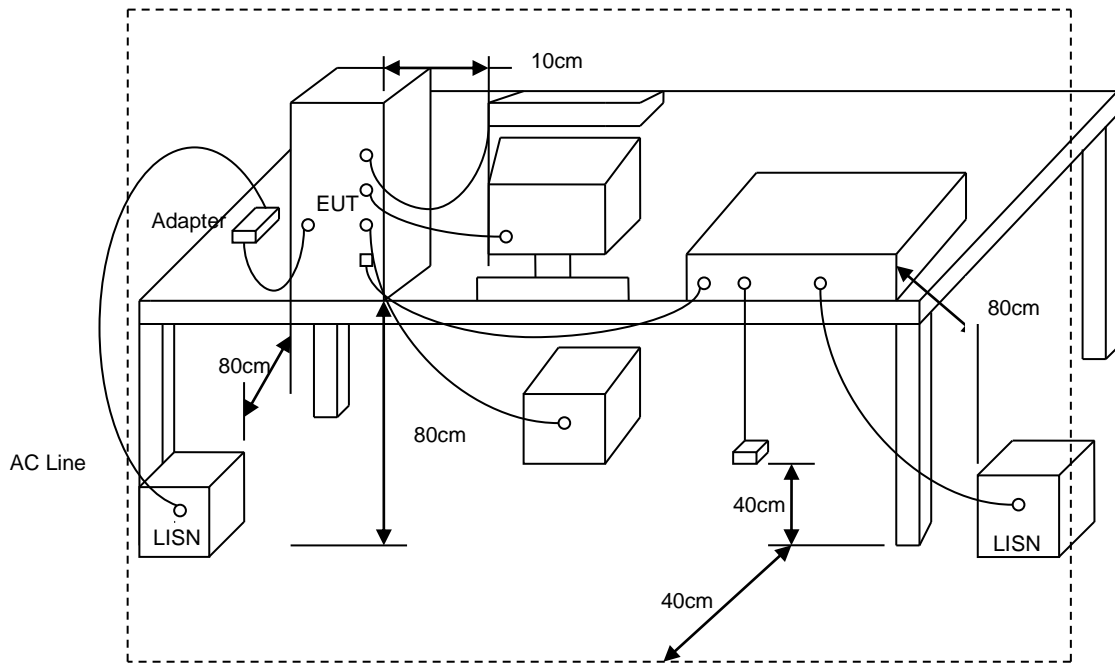



5.4 Test Result and Data

MIMO

Test Mode : 2TX 11ax20 CH06 NSS1 MCS0
Voltage : From Adapter(AC 120V/60Hz)
Phase : Line

Data: 9

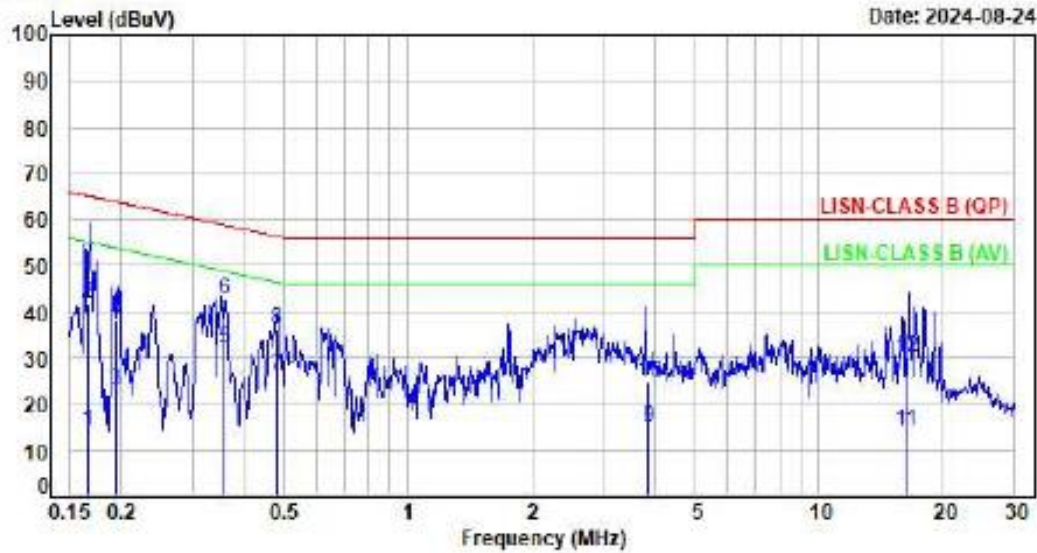

No.	Frequency (MHz)	Factor (dB)	Reading (dBuV)	Level (dBuV)	Limit (dBuV)	Margin (dB)	Detector	P/F
1	0.1666	9.92	4.32	14.24	55.13	-40.89	Average	P
2	0.1666	9.92	32.08	42.00	65.13	-23.13	QP	P
3	0.1944	9.92	12.82	22.74	53.85	-31.11	Average	P
4	0.1944	9.92	28.13	38.05	63.85	-25.80	QP	P
5	0.3568	9.93	21.82	31.75	48.80	-17.05	Average	P
6	0.3568	9.93	32.66	42.59	58.80	-16.21	QP	P
7	0.4772	9.93	16.44	26.37	46.39	-20.02	Average	P
8	0.4772	9.93	26.26	36.19	56.39	-20.20	QP	P
9	3.8320	10.08	4.66	14.74	46.00	-31.26	Average	P
10	3.8320	10.08	14.70	24.78	56.00	-31.22	QP	P
11	16.2818	10.63	3.28	13.91	50.00	-36.09	Average	P
12	16.2818	10.63	19.36	29.99	60.00	-30.01	QP	P

Note: Level=Reading+Factor
Margin=Level-Limit
Factor=(LISN or ISN or Current Probe)Factor + Cable Loss



Test Mode : 2TX 11ax20 CH06 NSS1 MCS0
Voltage : From Adapter(AC 120V/60Hz)
Phase : Neutral

Data: 10

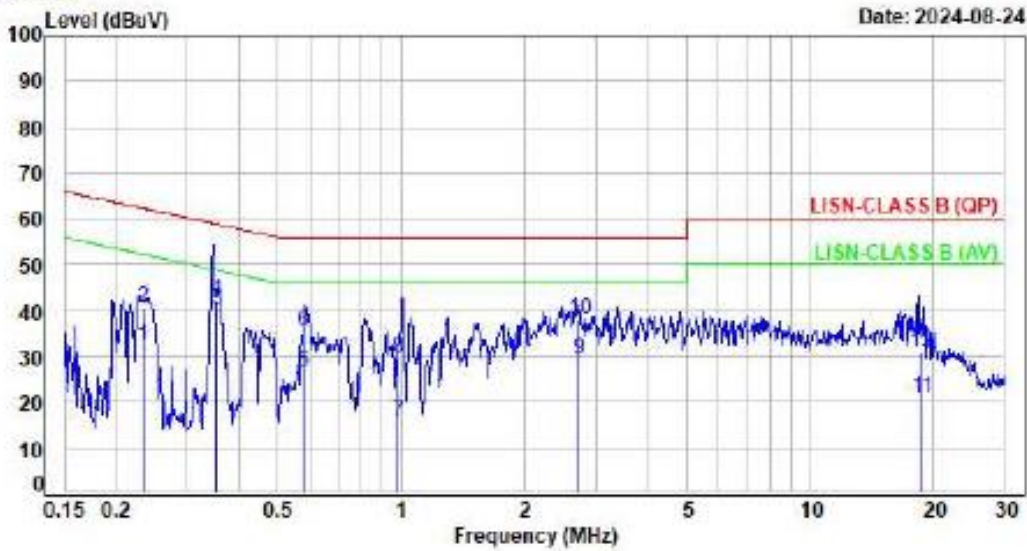

No.	Frequency (MHz)	Factor (dB)	Reading (dBuV)	Level (dBuV)	Limit (dBuV)	Margin (dB)	Detector	P/F
1	0.2350	9.94	22.45	32.39	52.27	-19.88	Average	P
2	0.2350	9.94	30.78	40.72	62.27	-21.55	QP	P
3	0.3539	9.96	30.32	40.28	48.87	-8.59	Average	P
4	0.3539	9.96	32.09	42.05	58.87	-16.82	QP	P
5	0.5793	9.96	16.83	26.79	46.00	-19.21	Average	P
6	0.5793	9.96	25.46	35.42	56.00	-20.58	QP	P
7	0.9835	9.99	5.68	15.67	46.00	-30.33	Average	P
8	0.9835	9.99	19.52	29.51	56.00	-26.49	QP	P
9	2.7281	10.06	19.10	29.16	46.00	-16.84	Average	P
10	2.7281	10.06	28.03	38.09	56.00	-17.91	QP	P
11	18.7387	10.61	10.31	20.92	50.00	-29.08	Average	P
12	18.7387	10.61	20.13	30.74	60.00	-29.26	QP	P

Note: Level=Reading+Factor
Margin=Level-Limit
Factor=(LISM or ISM or Current Probe)Factor + Cable Loss



6. Test of Radiated Spurious Emission

6.1 Test Limit

In any 100kHz bandwidth outside the frequency band in which the spread spectrum or digitally modulated intentional radiator is operating, the radio frequency power that is produced by the intentional radiator shall be at least 20dB below that in the 100kHz bandwidth within the band that contains the highest level of the desired power, based on either an RF conducted or a radiated measurement. If the transmitter measurement is based on the maximum conducted output power, the attenuation required under this paragraph shall be 30dB instead of 20dB. In addition, radiated emissions which fall in section 15.205(a) the restricted bands must also comply with the radiated emission limit specified in section 15.209(a).

Frequency (MHz)	Field Strength (microvolt/meter)	Measurement Distance (meters)
0.009 ~ 0.490	2400/F(kHz)	300
0.490 ~ 1.705	24000/F(kHz)	30
1.705 ~ 30.0	30	30
30 ~ 88	100	3
88 ~ 216	150	3
216 ~ 960	200	3
Above 960	500	3



6.2 Test Procedures

- a. The EUT was placed on a rotatable table top 0.8 meter above ground.
- b. The EUT was set 3 meters from the interference receiving antenna which was mounted on the top of a variable height antenna tower.
- c. The table was rotated 360 degrees to determine the position of the highest radiation.
- d. The antenna is a broadband antenna and its height is varied between one meter and four meters above ground to find the maximum value of the field strength both horizontal polarization and vertical polarization of the antenna are set to make the measurement.
- e. For each suspected emission the EUT was arranged to its worst case and then tune the antenna tower (from 1 M to 4 M) and turn table (from 0 degree to 360 degrees) to find the maximum reading.
- f. Set the test-receiver system to Peak or CISPR quasi-peak Detect Function and specified bandwidth with Maximum Hold Mode.
- g. If the emission level of the EUT in peak mode was 3 dB lower than the limit specified, then testing will be stopped and peak values of EUT will be reported, otherwise, the emissions which do not have 3 dB margin will be repeated one by one using the quasi-peak method and reported.
- h. For testing above 1GHz, the emission level of the EUT in peak mode was 20dB lower than average limit (that means the emission level in peak mode also complies with the limit in average mode), then testing will be stopped and peak values of EUT will be reported, otherwise, the emissions will be measured in average mode again and reported.
- i. "Cone of radiation" has been considered to be 3dB bandwidth of the measurement antenna.

Note:

- 1.The supporting fixture shall permit orientation of the EUT in each of three orthogonal axis positions such that emissions from the EUT are maximized.
- 2.Due to the test software function limit the operation band setting(200dBuV/m).
There's no corresponding limitation in the actual test item.



6.3 Typical Test Setup

Below 30MHz test setup

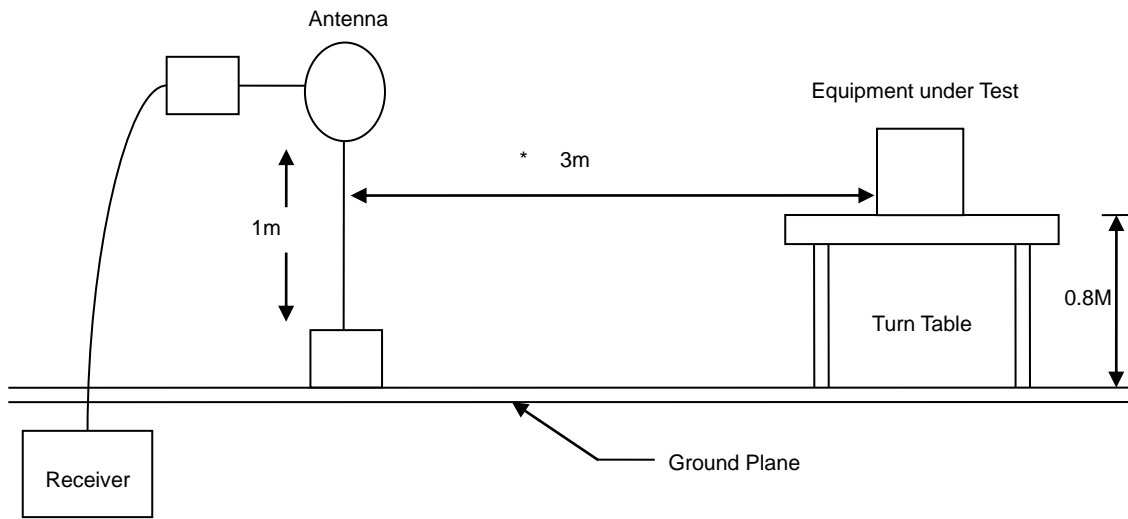

30MHz- 1GHz Test Setup

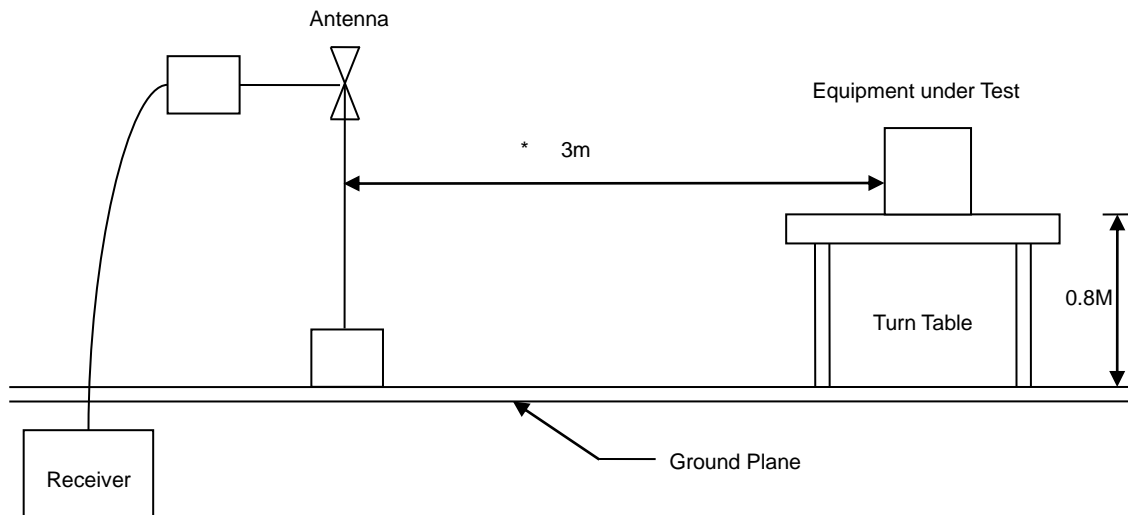



Above 1GHz Test Setup

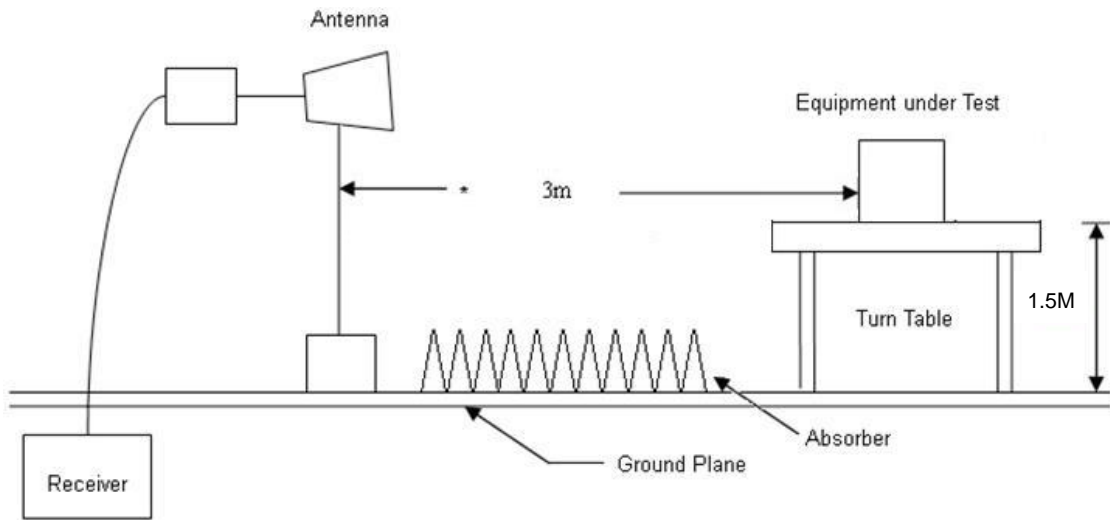



6.4 Test Result and Data (9KHz ~ 30MHz)

The 9kHz - 30MHz spurious emission is under limit 20dB more.

6.5 Test Result and Data (30MHz ~ 1GHz)

MIMO

Test Mode : 2TX 11ax20 CH06 NSS1 MC50
Voltage : From Adatper(AC240V/60Hz)
Pol : Vertical

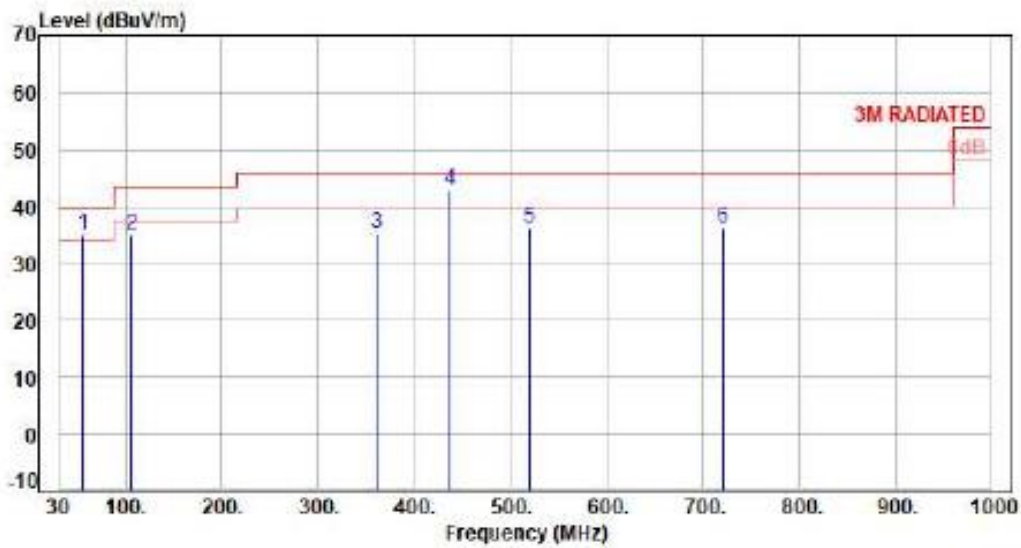

No.	Frequency (MHz)	Factor (dB)	Reading (dBuV)	Level (dBuV/m)	Limit (dBuV/m)	Margin (dB)	Detector	Height (cm)	Azimuth (deg)	P/F
1	55.22	-9.22	44.10	34.88	40.00	-5.12	Peak	400	0	P
2	105.66	-13.45	48.32	34.87	43.50	-8.63	Peak	400	0	P
3	361.74	-6.85	42.05	35.20	46.00	-10.80	Peak	400	0	P
4	437.40	-4.72	47.63	42.91	46.00	-3.09	Peak	400	0	P
5	518.88	-2.82	38.97	36.15	46.00	-9.85	Peak	400	0	P
6	720.64	0.84	35.32	36.16	46.00	-9.84	Peak	400	0	P

Note: Level=Reading+Factor
Margin=Level-Limit
Factor=Antenna Factor + cable loss - Amplifier Factor



Test Mode : 2TX 11ax20 CH06 NSS1 NC50
Voltage : From Adatper(AC240V/60Hz)
Pol : Horizontal

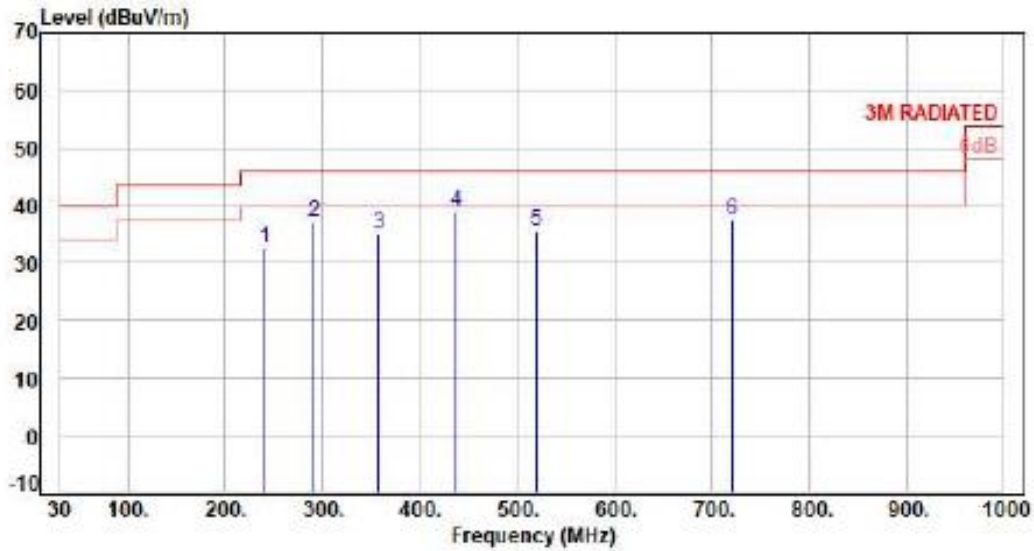

No.	Frequency (MHz)	Factor (dB)	Reading (dBuV)	Level (dBuV/m)	Limit (dBuV/m)	Margin (dB)	Detector	Height (cm)	Azimuth (deg)	P/F
1	241.46	-10.44	42.92	32.48	46.00	-13.52	Peak	400	360	P
2	291.90	-8.68	45.69	37.01	46.00	-8.99	Peak	400	360	P
3	357.86	-7.03	42.15	35.12	46.00	-10.88	Peak	400	360	P
4	437.40	-4.72	43.76	39.04	46.00	-6.96	Peak	400	360	P
5	518.88	-2.82	38.44	35.62	46.00	-10.38	Peak	400	360	P
6	720.64	0.84	36.52	37.36	46.00	-8.64	Peak	400	360	P

Note: Level=Reading+Factor
Margin=Level-Limit
Factor=Antenna Factor + cable loss - Amplifier Factor



6.6 Test Result and Data (1GHz ~ 25GHz)

SISO ANT B

Test Mode : 1TX 11b CH01 1Mbps
 Voltage : From Adapter(AC120V/60Hz)
 Pol : Vertical

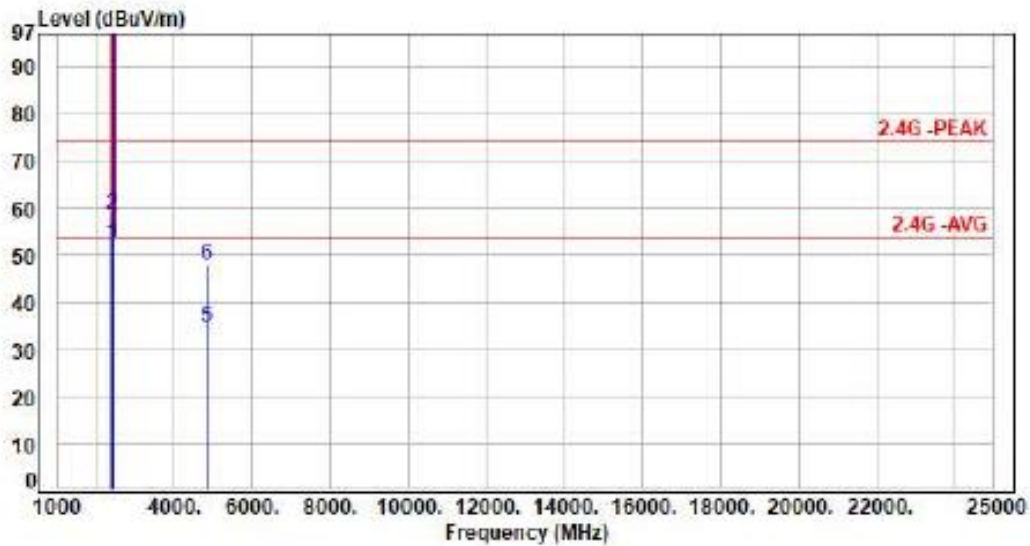

No.	Frequency (MHz)	Factor (dB)	Reading (dBuV)	Level (dBuV/m)	Limit (dBuV/m)	Margin (dB)	Detector	Height (cm)	Azimuth (deg)	P/F
1	2390.00	-2.33	54.79	52.46	54.00	-1.54	Average	230	339	P
2	2390.00	-2.33	60.95	58.62	74.00	-15.38	Peak	230	339	P
3	2412.00	-2.29	106.08	103.79	200.00	-96.21	Average	230	339	P
4	2412.00	-2.29	109.58	107.29	200.00	-92.71	Peak	230	339	P
5	4824.00	5.98	28.67	34.65	54.00	-19.35	Average	100	257	P
6	4824.00	5.98	41.87	47.85	74.00	-26.15	Peak	100	257	P

Note: Level=Reading+Factor
 Margin=Level-Limit
 Factor=Antenna Factor + cable loss - Amplifier Factor



Test Mode : 1TX 11b CH01 1Mbps
Voltage : From Adapter(AC120V/60Hz)
Pol : Horizontal

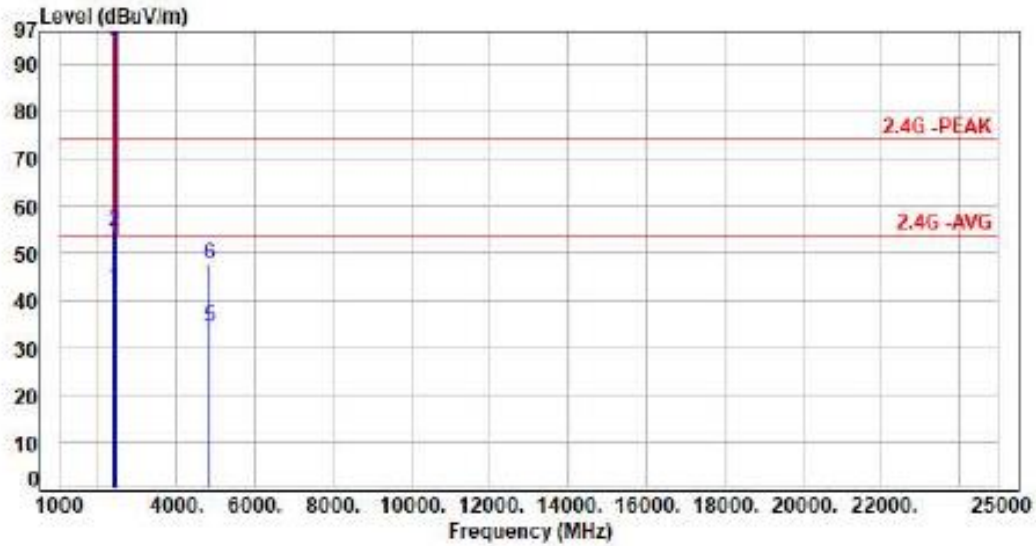

No.	Frequency (MHz)	Factor (dB)	Reading (dBuV)	Level (dBuV/m)	Limit (dBuV/m)	Margin (dB)	Detector	Height (cm)	Azimuth (deg)	P/F
1	2398.00	-2.33	45.19	42.86	54.00	-11.14	Average	100	263	P
2	2398.00	-2.33	57.03	54.70	74.00	-19.30	Peak	100	263	P
3	2412.00	-2.29	97.17	94.88	200.00	-105.12	Average	100	263	P
4	2412.00	-2.29	99.72	97.43	200.00	-102.57	Peak	100	263	P
5	4824.00	5.98	28.49	34.47	54.00	-19.53	Average	100	360	P
6	4824.00	5.98	41.58	47.56	74.00	-26.44	Peak	100	360	P

Note: Level=Reading+Factor
Margin=Level-Limit
Factor=Antenna Factor + cable loss - Amplifier Factor



Test Mode : ITX 11b CH06 IMbos
Voltage : From Adapter(AC120V/60Hz)
Pol : Vertical

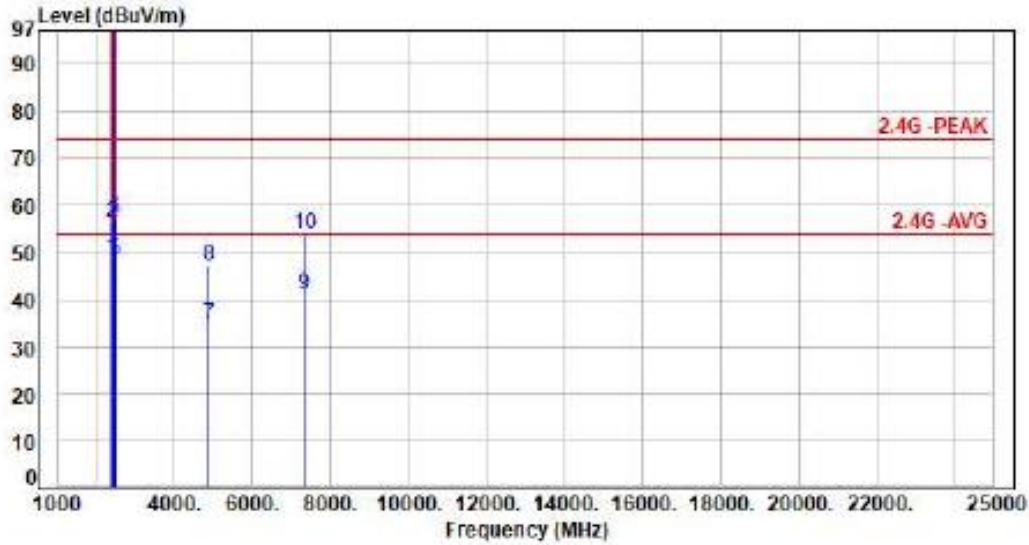

No.	Frequency (MHz)	Factor (dB)	Reading (dBuV)	Level (dBuV/m)	Limit (dBuV/m)	Margin (dB)	Detector	Height (cm)	Azimuth (deg)	P/F
1	2398.00	-2.33	50.99	48.66	54.00	-5.34	Average	219	352	P
2	2398.00	-2.33	58.85	56.52	74.00	-17.48	Peak	219	352	P
3	2437.00	-2.17	107.68	105.51	200.00	-94.29	Average	219	352	P
4	2437.00	-2.17	110.14	107.97	200.00	-92.03	Peak	219	352	P
5	2483.50	-2.01	50.29	48.28	54.00	-5.72	Average	219	352	P
6	2483.50	-2.01	59.12	57.11	74.00	-16.89	Peak	219	352	P
7	4874.00	6.13	28.36	34.49	54.00	-19.51	Average	100	144	P
8	4874.00	6.13	41.14	47.27	74.00	-26.73	Peak	100	144	P
9	7311.00	11.23	29.54	40.77	54.00	-13.23	Average	100	251	P
10	7311.00	11.23	42.64	53.87	74.00	-20.13	Peak	100	251	P

Note: Level=Reading+Factor
Margin=Level-Limit
Factor=Antenna Factor + cable loss - Amplifier Factor



Test Mode : 1TX 11b CH06 1Mbps
 Voltage : From Adapter(AC120V/60Hz)
 Pol : Horizontal

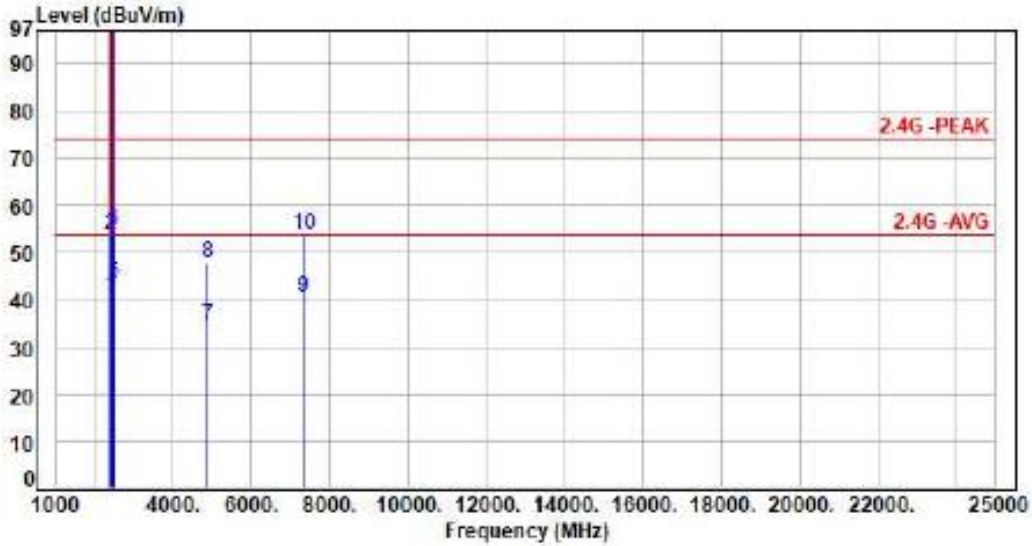

No.	Frequency (MHz)	Factor (dB)	Reading (dBuV)	Level (dBuV/m)	Limit (dBuV/m)	Margin (dB)	Detector	Height (cm)	Azimuth (deg)	P/F
1	2390.00	-2.33	43.43	41.10	54.00	-12.90	Average	247	295	P
2	2390.00	-2.33	56.14	53.81	74.00	-20.19	Peak	247	295	P
3	2437.00	-2.17	98.78	96.61	200.00	-103.39	Average	247	295	P
4	2437.00	-2.17	101.28	99.11	200.00	-100.89	Peak	247	295	P
5	2483.50	-2.01	45.61	43.60	54.00	-10.40	Average	247	295	P
6	2483.50	-2.01	56.63	54.62	74.00	-19.38	Peak	247	295	P
7	4874.00	6.13	28.57	34.70	54.00	-19.30	Average	100	157	P
8	4874.00	6.13	41.74	47.87	74.00	-26.13	Peak	100	157	P
9	7311.00	11.23	29.38	40.61	54.00	-13.39	Average	100	246	P
10	7311.00	11.23	42.70	53.93	74.00	-20.07	Peak	100	246	P

Note: Level=Reading+Factor
 Margin=Level-Limit
 Factor=Antenna Factor + cable loss - Amplifier Factor



Test Mode : 1TX 11b CH11 1Mbps
Voltage : From Adapter(AC120V/60Hz)
Pol : Vertical

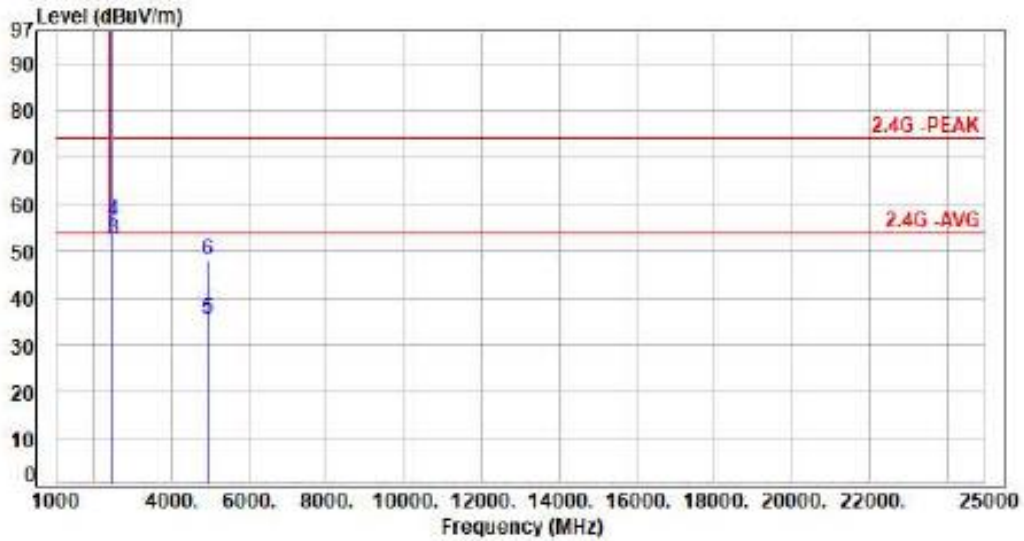

No.	Frequency (MHz)	Factor (dB)	Reading (dBuV)	Level (dBuV/m)	Limit (dBuV/m)	Margin (dB)	Detector	Height (cm)	Azimuth (deg)	P/F
1	2462.00	-2.04	103.75	101.71	200.00	-98.29	Average	120	180	P
2	2462.00	-2.04	106.33	104.29	200.00	-95.71	Peak	120	180	P
3	2483.50	-2.01	54.35	52.34	54.00	-1.66	Average	120	180	P
4	2483.50	-2.01	58.29	56.28	74.00	-17.72	Peak	120	180	P
5	4924.00	6.29	29.03	35.32	54.00	-18.68	Average	100	177	P
6	4924.00	6.29	41.67	47.96	74.00	-26.04	Peak	100	177	P

Note: Level=Reading+Factor
Margin=Level-Limit
Factor=Antenna Factor + cable loss - Amplifier Factor



Test Mode : ITX 11b CH11 1Mbps
Voltage : From Adapter(AC120V/60Hz)
Pol : Horizontal

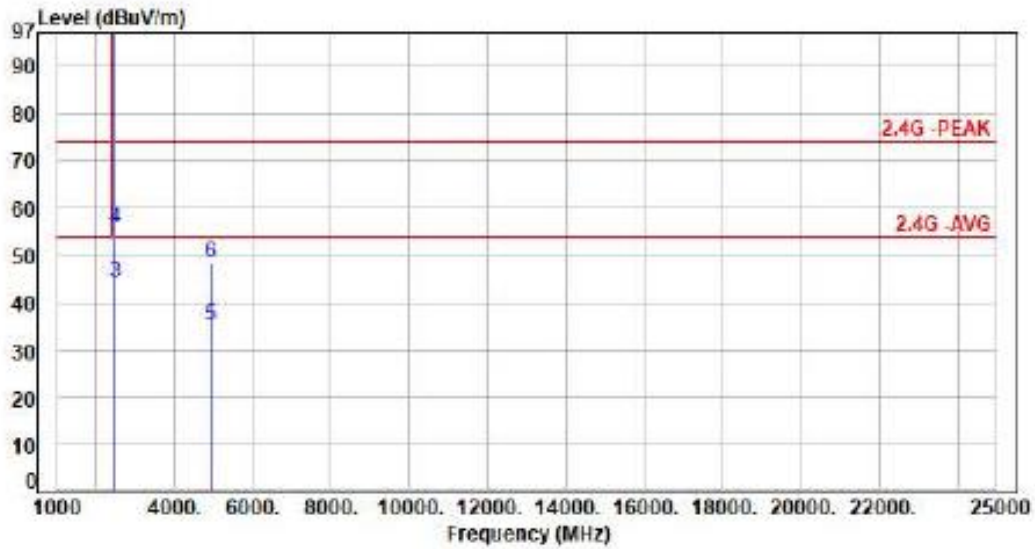

No.	Frequency (MHz)	Factor (dB)	Reading (dBuV)	Level (dBuV/m)	Limit (dBuV/m)	Margin (dB)	Detector	Height (cm)	Azimuth (deg)	P/F
1	2462.00	-2.04	98.27	96.23	200.00	-103.77	Average	120	357	P
2	2462.00	-2.04	100.68	98.64	200.00	-101.36	Peak	120	357	P
3	2483.50	-2.01	46.14	44.13	54.00	-9.87	Average	120	357	P
4	2483.50	-2.01	57.77	55.76	74.00	-18.24	Peak	120	357	P
5	4924.00	6.29	28.65	34.94	54.00	-19.06	Average	100	153	P
6	4924.00	6.29	42.04	48.33	74.00	-25.67	Peak	100	153	P

Note: Level=Reading+Factor
Margin=Level-Limit
Factor=Antenna Factor + cable loss - Amplifier Factor



Test Mode : 1TX 11b CH12 1Mbps
Voltage : From Adapter(AC120V/60Hz)
Pol : Vertical

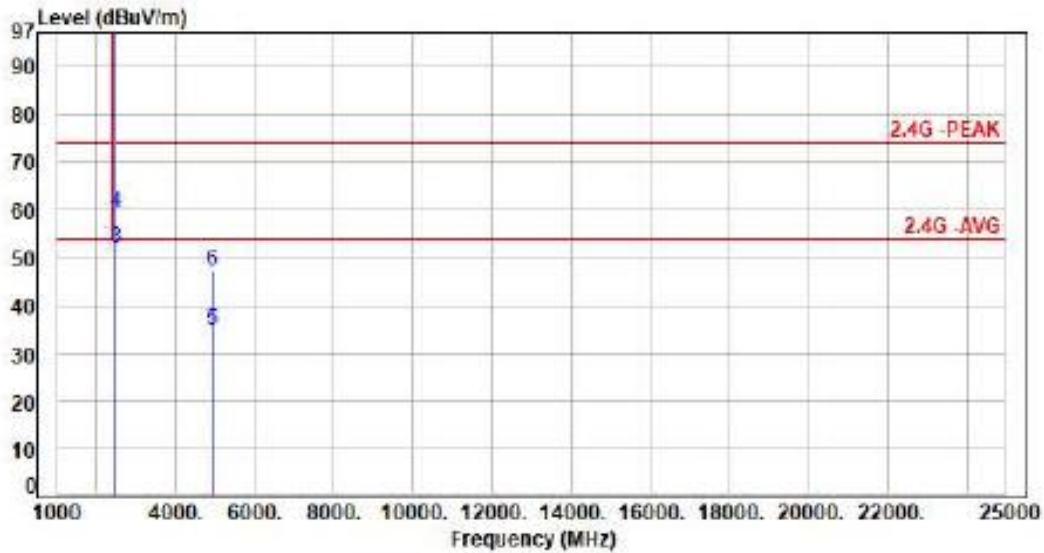

No.	Frequency (MHz)	Factor (dB)	Reading (dBuV)	Level (dBuV/m)	Limit (dBuV/m)	Margin (dB)	Detector	Height (cm)	Azimuth (deg)	P/F
1	2467.00	-2.03	100.88	98.85	200.00	-101.15	Average	100	182	P
2	2467.00	-2.03	103.99	101.96	200.00	-98.04	Peak	100	182	P
3	2483.50	-2.01	54.02	52.01	54.00	-1.99	Average	100	182	P
4	2483.50	-2.01	61.48	59.47	74.00	-14.53	Peak	100	182	P
5	4934.00	6.32	28.36	34.68	54.00	-19.32	Average	100	193	P
6	4934.00	6.32	41.04	47.36	74.00	-26.64	Peak	100	193	P

Note: Level=Reading+Factor
Margin=Level-Limit
Factor=Antenna Factor + cable loss - Amplifier Factor



Test Mode : 1TX 11b CH12 1Mbps
 Voltage : From Adapter(AC120V/60Hz)
 Pol : Horizontal

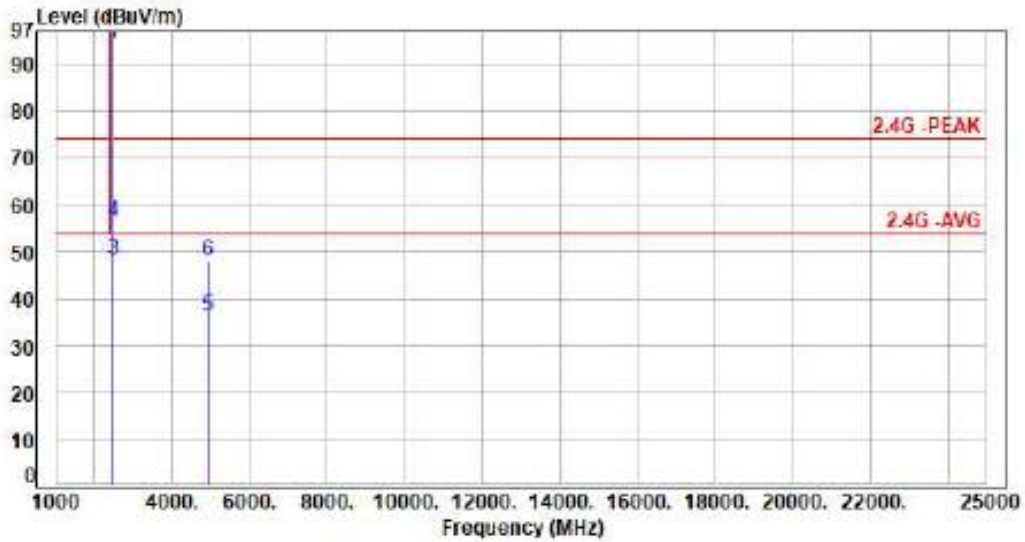

No.	Frequency (MHz)	Factor (dB)	Reading (dBuV)	Level (dBuV/m)	Limit (dBuV/m)	Margin (dB)	Detector	Height (cm)	Azimuth (deg)	P/F
1	2467.00	-2.03	96.48	94.45	200.00	-105.55	Average	134	340	P
2	2467.00	-2.03	98.98	96.95	200.00	-103.05	Peak	134	340	P
3	2483.50	-2.01	50.27	48.26	54.00	-5.74	Average	134	340	P
4	2483.50	-2.01	58.55	56.54	74.00	-17.46	Peak	134	340	P
5	4934.00	6.32	29.66	35.98	54.00	-18.02	Average	100	255	P
6	4934.00	6.32	41.76	48.08	74.00	-25.92	Peak	100	255	P

Note: Level=Reading+Factor
 Margin=Level-Limit
 Factor=Antenna Factor + cable loss - Amplifier Factor



Test Mode : ITX 11b CH13 1Mbps
Voltage : From Adapter(AC120V/60Hz)
Pol : Vertical

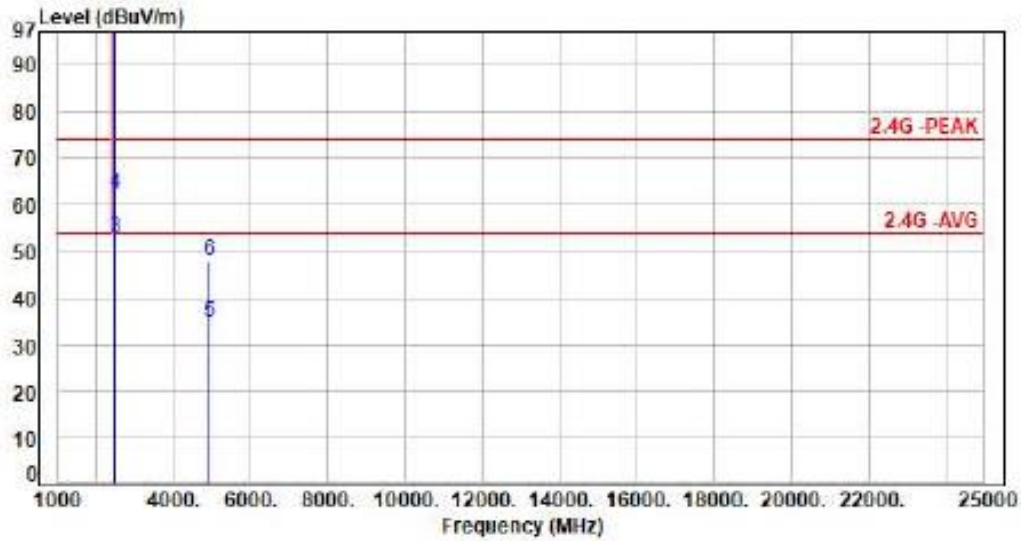

No.	Frequency (MHz)	Factor (dB)	Reading (dBuV)	Level (dBuV/m)	Limit (dBuV/m)	Margin (dB)	Detector	Height (cm)	Azimuth (deg)	P/F
1	2472.00	-2.02	100.62	98.60	200.00	-101.40	Average	100	182	P
2	2472.00	-2.02	103.12	101.10	200.00	-98.90	Peak	100	182	P
3	2483.50	-2.01	54.73	52.72	54.00	-1.28	Average	100	182	P
4	2483.50	-2.01	64.43	62.42	74.00	-11.58	Peak	100	182	P
5	4944.00	6.35	28.29	34.64	54.00	-19.36	Average	100	189	P
6	4944.00	6.35	41.45	47.80	74.00	-26.20	Peak	100	189	P

Note: Level=Reading+Factor
Margin=Level-Limit
Factor=Antenna Factor + cable loss - Amplifier Factor



Test Mode : 1TX 11b CH13 1Mbps
Voltage : From Adapter(AC120V/60Hz)
Pol : Horizontal

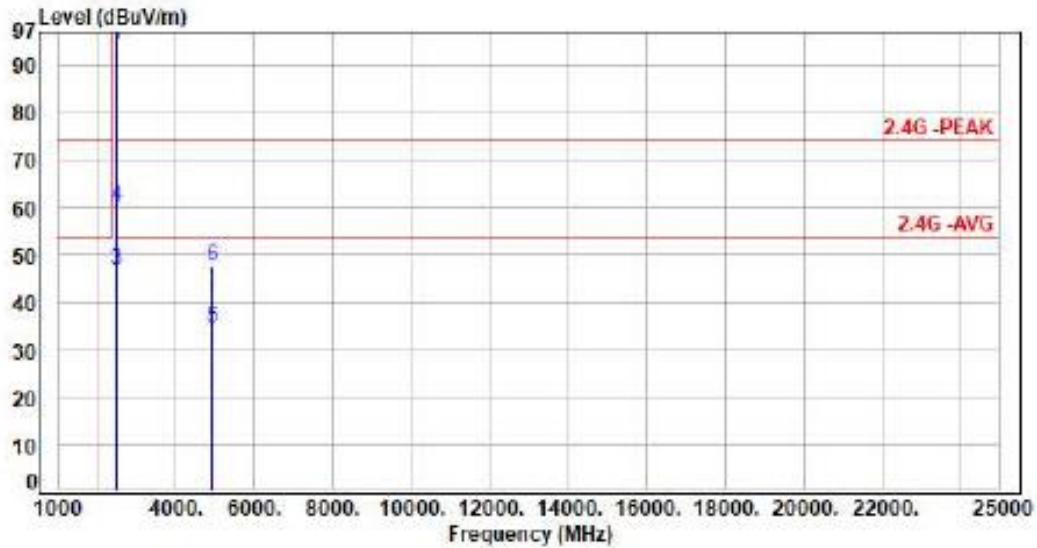

No.	Frequency (MHz)	Factor (dB)	Reading (dBuV)	Level (dBuV/m)	Limit (dBuV/m)	Margin (dB)	Detector	Height (cm)	Azimuth (deg)	P/F
1	2472.00	-2.02	96.50	94.48	200.00	-105.52	Average	100	336	P
2	2472.00	-2.02	99.20	97.26	200.00	-102.74	Peak	100	336	P
3	2483.50	-2.01	48.72	46.71	54.00	-7.29	Average	100	336	P
4	2483.50	-2.01	62.22	60.21	74.00	-13.79	Peak	100	336	P
5	4944.00	6.35	28.21	34.56	54.00	-19.44	Average	100	352	P
6	4944.00	6.35	41.24	47.59	74.00	-26.41	Peak	100	352	P

Note: Level=Reading+Factor
Margin=Level-Limit
Factor=Antenna Factor + cable loss - Amplifier Factor



Test Mode : 1TX-11g CH01 6Mbps
Voltage : From Adapter(AC120V/60Hz)
Pol : Vertical

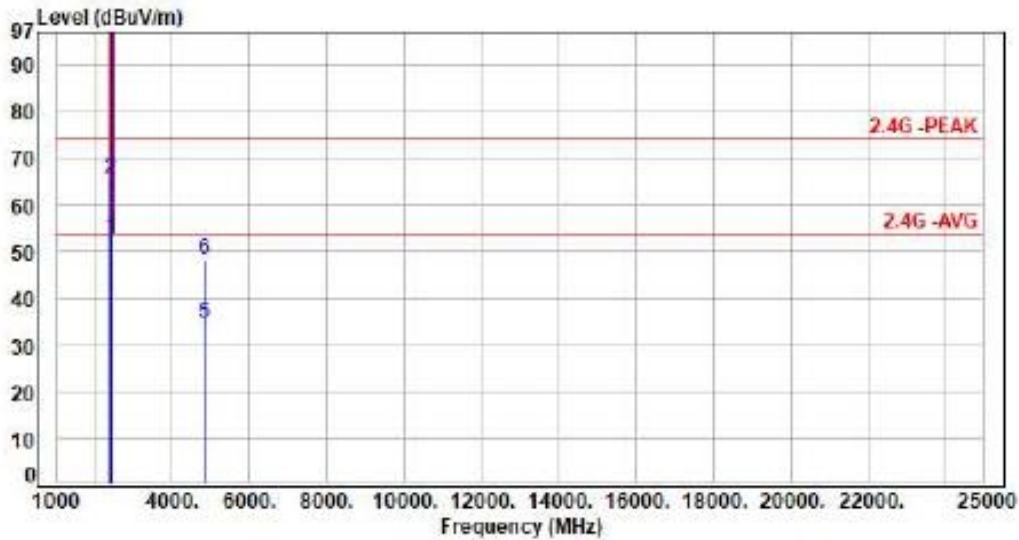

No.	Frequency (MHz)	Factor (dB)	Reading (dBuV)	Level (dBuV/m)	Limit (dBuV/m)	Margin (dB)	Detector	Height (cm)	Azimuth (deg)	P/F
1	2390.00	-2.33	55.26	52.93	54.00	-1.07	Average	226	355	P
2	2390.00	-2.33	67.93	65.60	74.00	-8.40	Peak	226	355	P
3	2412.00	-2.29	101.30	99.01	200.00	-100.99	Average	226	355	P
4	2412.00	-2.29	111.46	109.17	200.00	-90.83	Peak	226	355	P
5	4824.00	5.98	28.64	34.62	54.00	-19.38	Average	100	177	P
6	4824.00	5.98	42.46	48.44	74.00	-25.56	Peak	100	177	P

Note: Level=Reading+Factor
Margin=Level-Limit
Factor=Antenna Factor + cable loss - Amplifier Factor



Test Mode : 1TX 11g CH01 6Mbps
Voltage : From Adapter(AC120V/60Hz)
Pol : Horizontal

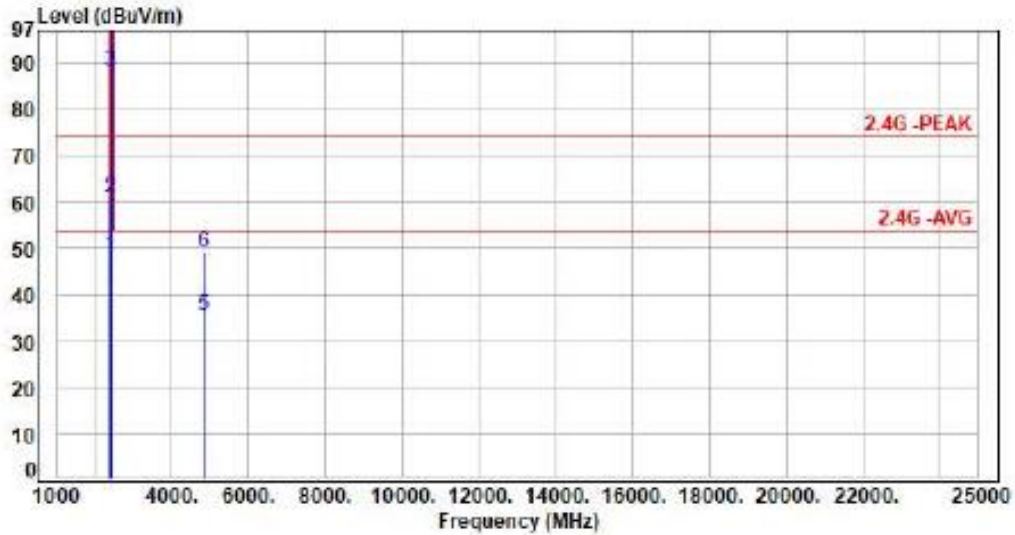

No.	Frequency (MHz)	Factor (dB)	Reading (dBuV)	Level (dBuV/m)	Limit (dBuV/m)	Margin (dB)	Detector	Height (cm)	Azimuth (deg)	P/F
1	2390.00	-2.33	50.54	48.21	54.00	-5.79	Average	100	264	P
2	2390.00	-2.33	63.02	60.69	74.00	-13.31	Peak	100	264	P
3	2412.00	-2.29	90.51	88.22	200.00	-111.78	Average	100	264	P
4	2412.00	-2.29	100.04	97.75	200.00	-102.25	Peak	100	264	P
5	4824.00	5.98	29.48	35.46	54.00	-18.54	Average	100	174	P
6	4824.00	5.98	43.10	49.08	74.00	-24.92	Peak	100	174	P

Note: Level=Reading+Factor
Margin=Level-Limit
Factor=Antenna Factor + cable loss - Amplifier Factor



Test Mode : ITX 11g CH06 6Mbps
Voltage : From Adapter(AC120V/60Hz)
Pol : Vertical

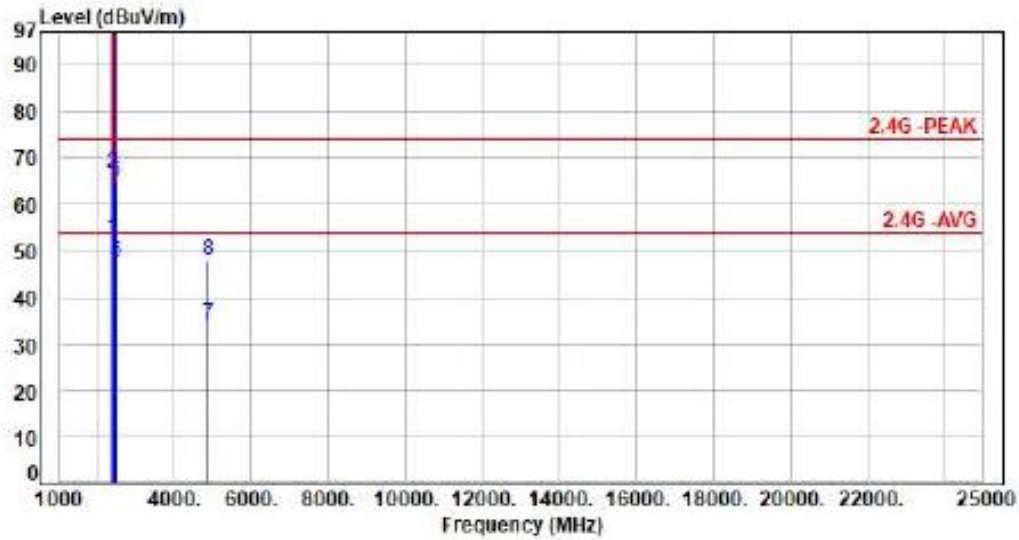

No.	Frequency (MHz)	Factor (dB)	Reading (dBuV)	Level (dBuV/m)	Limit (dBuV/m)	Margin (dB)	Detector	Height (cm)	Azimuth (deg)	P/F
1	2390.00	-2.33	55.16	52.83	54.00	-1.17	Average	100	182	P
2	2390.00	-2.33	69.18	66.85	74.00	-7.15	Peak	100	182	P
3	2437.00	-2.17	99.58	97.41	200.00	-102.59	Average	100	182	P
4	2437.00	-2.17	109.69	107.52	200.00	-92.48	Peak	100	182	P
5	2483.50	-2.01	49.41	47.40	54.00	-6.60	Average	100	182	P
6	2483.50	-2.01	66.89	64.88	74.00	-9.12	Peak	100	182	P
7	4874.00	6.13	28.13	34.26	54.00	-19.74	Average	100	119	P
8	4874.00	6.13	41.81	47.94	74.00	-26.06	Peak	100	119	P

Note: Level=Reading+Factor
Margin=Level-Limit
Factor=Antenna Factor + cable loss - Amplifier Factor



Test Mode : 1TX 11g CH06 6Mbps
 Voltage : From Adapter(AC120V/60Hz)
 Pol : Horizontal

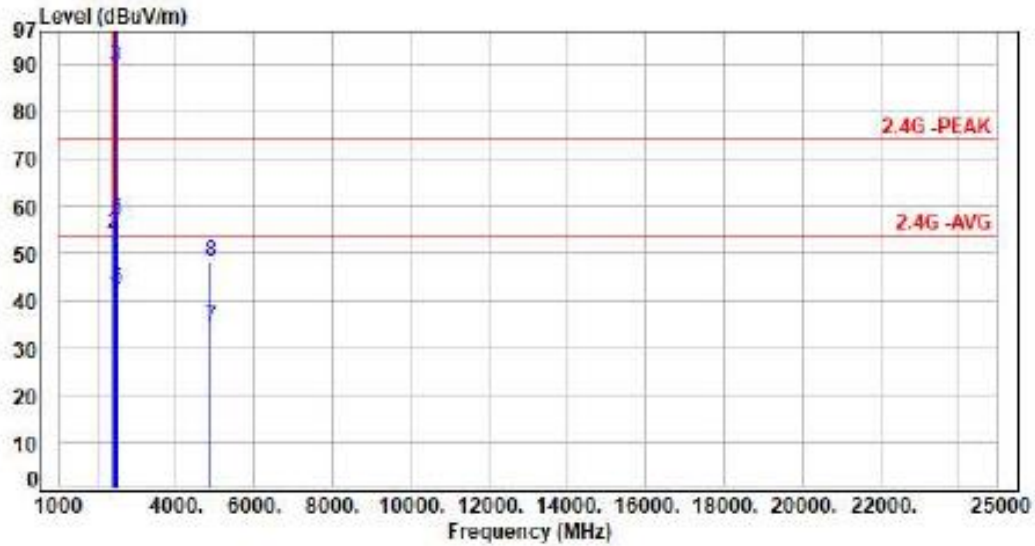

No.	Frequency (MHz)	Factor (dB)	Reading (dBuV)	Level (dBuV/m)	Limit (dBuV/m)	Margin (dB)	Detector	Height (cm)	Azimuth (deg)	P/F
1	2398.08	-2.33	43.57	41.24	54.08	-12.76	Average	100	278	P
2	2398.08	-2.33	56.39	54.06	74.08	-19.94	Peak	100	278	P
3	2437.08	-2.17	91.68	89.51	200.08	-110.49	Average	100	278	P
4	2437.08	-2.17	101.83	98.86	200.08	-101.14	Peak	100	278	P
5	2483.58	-2.01	44.58	42.57	54.08	-11.43	Average	100	278	P
6	2483.58	-2.01	59.12	57.11	74.08	-16.89	Peak	100	278	P
7	4874.08	6.13	28.01	34.14	54.08	-19.86	Average	100	135	P
8	4874.08	6.13	42.06	48.19	74.08	-25.81	Peak	100	135	P

Note: Level=Reading+Factor
 Margin=Level-Limit
 Factor=Antenna Factor + cable loss - Amplifier Factor



Test Mode : 1TX 11g CH11 6Mbps
Voltage : From Adapter(AC120V/60Hz)
Pol : Vertical

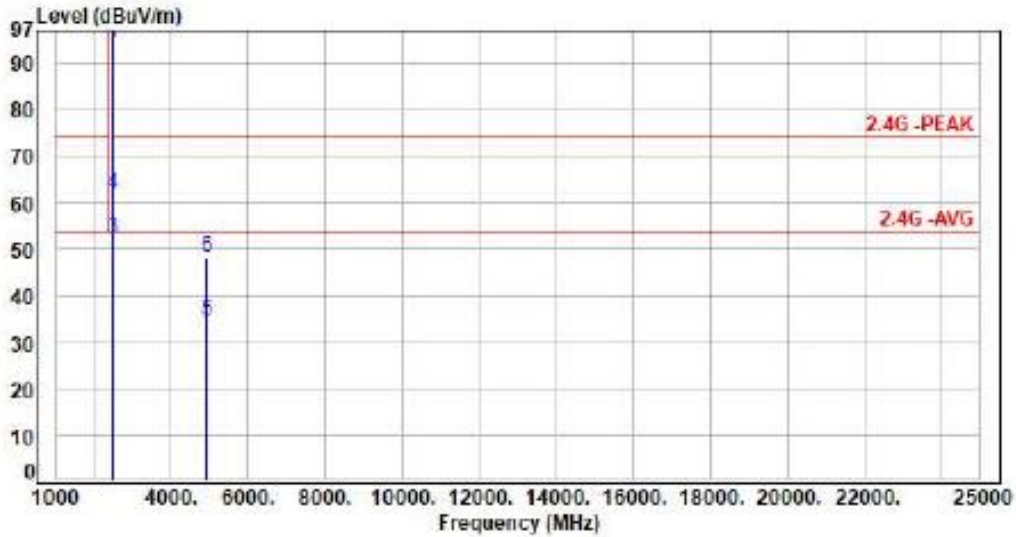

No.	Frequency (MHz)	Factor (dB)	Reading (dBuV)	Level (dBuV/m)	Limit (dBuV/m)	Margin (dB)	Detector	Height (cm)	Azimuth (deg)	P/F
1	2462.00	-2.04	96.61	94.57	200.00	-105.43	Average	100	185	P
2	2462.00	-2.04	105.18	103.14	200.00	-96.86	Peak	100	185	P
3	2483.50	-2.01	54.22	52.21	54.00	-1.79	Average	100	185	P
4	2483.50	-2.01	64.14	62.13	74.00	-11.87	Peak	100	185	P
5	4924.00	6.29	28.30	34.59	54.00	-19.41	Average	100	195	P
6	4924.00	6.29	42.06	48.35	74.00	-25.65	Peak	100	195	P

Note: Level=Reading+Factor
Margin=Level-Limit
Factor=Antenna Factor + cable loss - Amplifier Factor



Test Mode : 1TX 11g CH11 6Mbps
Voltage : From Adapter(AC120V/60Hz)
Pol : Horizontal

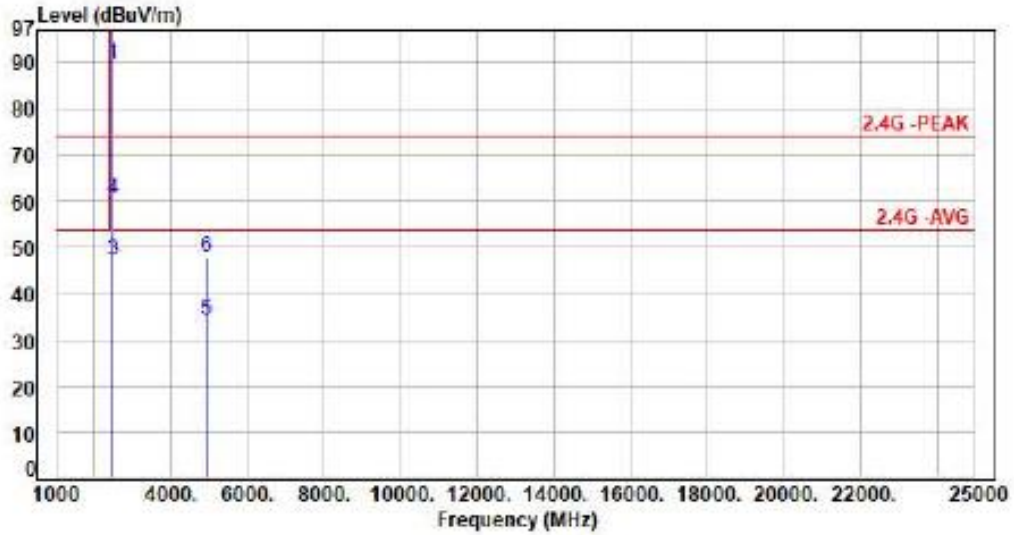

No.	Frequency (MHz)	Factor (dB)	Reading (dBUV)	Level (dBUV/m)	Limit (dBUV/m)	Margin (dB)	Detector	Height (cm)	Azimuth (deg)	P/F
1	2462.00	-2.04	91.49	89.45	200.00	-110.55	Average	100	337	P
2	2462.00	-2.04	100.62	98.58	200.00	-101.42	Peak	100	337	P
3	2483.50	-2.01	49.17	47.16	54.00	-6.84	Average	100	337	P
4	2483.50	-2.01	62.56	60.55	74.00	-13.45	Peak	100	337	P
5	4924.00	6.29	28.17	34.46	54.00	-19.54	Average	100	116	P
6	4924.00	6.29	41.56	47.85	74.00	-26.15	Peak	100	116	P

Note: Level=Reading+Factor
Margin=Level-Limit
Factor=Antenna Factor + cable loss - Amplifier Factor



Test Mode : 1TX 11g CH12 6Mbps
Voltage : From Adapter(AC120V/60Hz)
Pol : Vertical

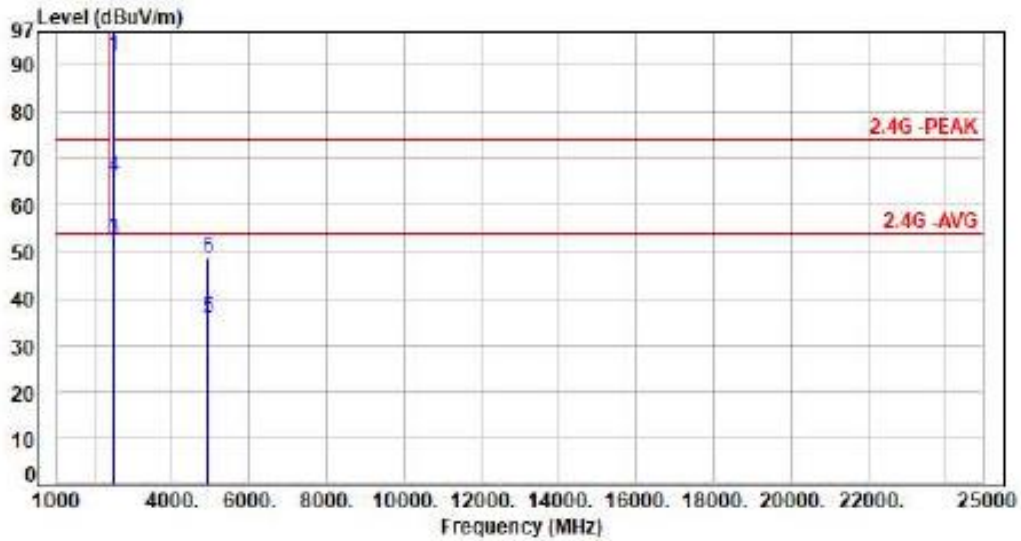

No.	Frequency (MHz)	Factor (dB)	Reading (dBuV)	Level (dBuV/m)	Limit (dBuV/m)	Margin (dB)	Detector	Height (cm)	Azimuth (deg)	P/F
1	2467.00	-2.03	93.78	91.75	200.00	-108.25	Average	100	185	P
2	2467.00	-2.03	102.23	100.20	200.00	-99.80	Peak	100	185	P
3	2483.50	-2.01	54.55	52.54	54.00	-1.46	Average	100	185	P
4	2483.50	-2.01	67.86	65.85	74.00	-8.15	Peak	100	185	P
5	4934.00	6.32	29.64	35.96	54.00	-18.04	Average	100	199	P
6	4934.00	6.32	42.55	48.87	74.00	-25.13	Peak	100	199	P

Note: Level=Reading+Factor
Margin=Level-Limit
Factor=Antenna Factor + cable loss - Amplifier Factor



Test Mode : 1TX 11g CH12 6Mbps
Voltage : From Adapter(AC120V/60Hz)
Pol : Horizontal

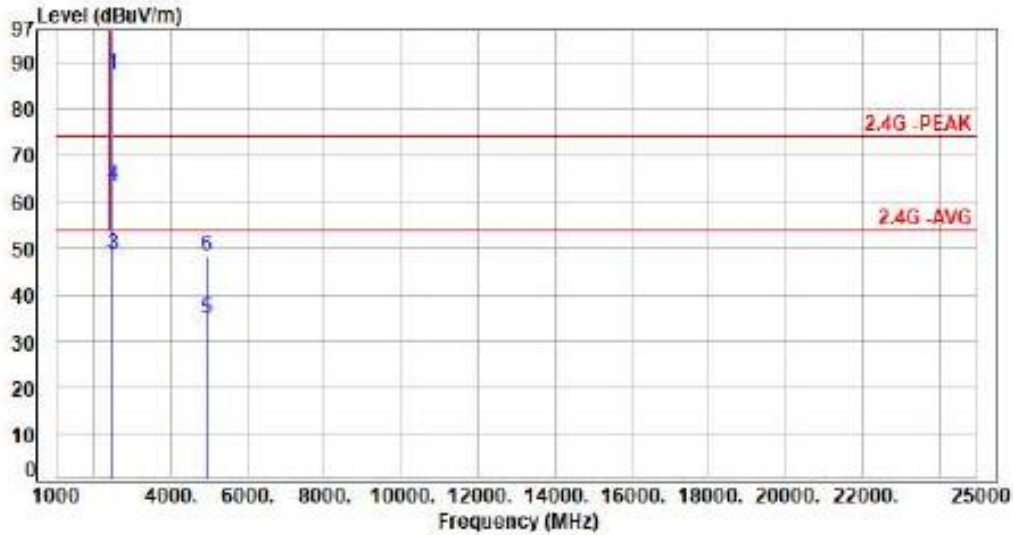

No.	Frequency (MHz)	Factor (dB)	Reading (dBuV)	Level (dBuV/m)	Limit (dBuV/m)	Margin (dB)	Detector	Height (cm)	Azimuth (deg)	P/F
1	2467.00	-2.03	89.29	87.26	200.00	-112.74	Average	120	337	P
2	2467.00	-2.03	98.27	96.24	200.00	-103.76	Peak	120	337	P
3	2483.50	-2.01	50.75	48.74	54.00	-5.26	Average	120	337	P
4	2483.50	-2.01	65.29	63.28	74.00	-10.72	Peak	120	337	P
5	4934.00	6.32	28.41	34.73	54.00	-19.27	Average	100	194	P
6	4934.00	6.32	42.13	48.45	74.00	-25.55	Peak	100	194	P

Note: Level=Reading+Factor
Margin=Level-Limit
Factor=Antenna Factor + cable loss - Amplifier Factor



Test Mode : 1TX 11g CH13 6Mbps
Voltage : From Adapter(AC120V/60Hz)
Pol : Vertical

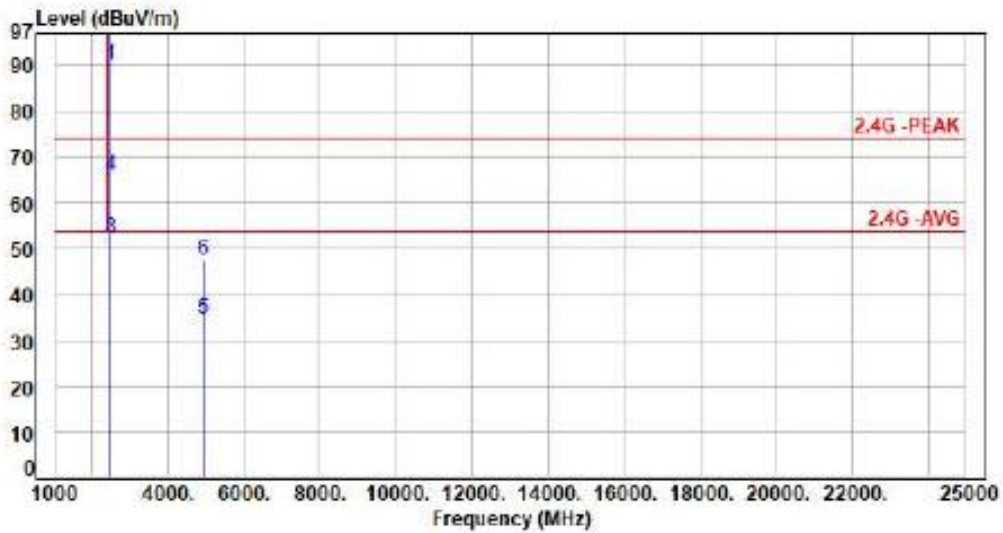

No.	Frequency (MHz)	Factor (dB)	Reading (dBuV)	Level (dBuV/m)	Limit (dBuV/m)	Margin (dB)	Detector	Height (cm)	Azimuth (deg)	P/F
1	2472.00	-2.02	91.16	90.14	200.00	-109.86	Average	100	181	P
2	2472.00	-2.02	101.37	99.35	200.00	-100.65	Peak	100	181	P
3	2483.50	-2.01	54.56	52.55	54.00	-1.45	Average	100	181	P
4	2483.50	-2.01	67.97	65.96	74.00	-8.04	Peak	100	181	P
5	4944.00	6.35	28.36	34.71	54.00	-19.29	Average	100	181	P
6	4944.00	6.35	41.18	47.53	74.00	-26.47	Peak	100	181	P

Note: Level=Reading+Factor
Margin=Level-Limit
Factor=Antenna Factor + cable loss - Amplifier Factor



Test Mode : ITX 11g CH13 6Mbps
Voltage : From Adapter(AC120V/60Hz)
Pol : Horizontal

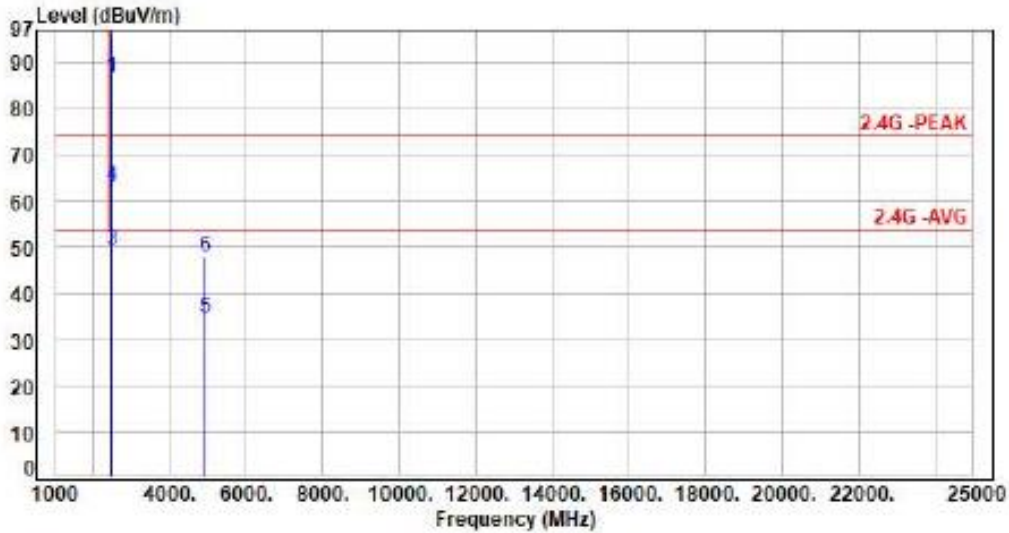

No.	Frequency (MHz)	Factor (dB)	Reading (dBuV)	Level (dBuV/m)	Limit (dBuV/m)	Margin (dB)	Detector	Height (cm)	Azimuth (deg)	P/F
1	2472.00	-2.02	88.53	86.51	200.00	-113.49	Average	100	337	P
2	2472.00	-2.02	98.02	96.00	200.00	-104.00	Peak	100	337	P
3	2483.50	-2.01	51.40	49.39	54.00	-4.61	Average	100	337	P
4	2483.50	-2.01	65.21	63.20	74.00	-10.80	Peak	100	337	P
5	4944.00	6.35	28.38	34.73	54.00	-19.27	Average	100	360	P
6	4944.00	6.35	41.70	48.05	74.00	-25.95	Peak	100	360	P

Note: Level=Reading+Factor
Margin=Level-Limit
Factor=Antenna Factor + cable loss - Amplifier Factor