



FCC DFS TEST REPORT

Applicant : Elo Touch Solutions, Inc.
Address : 670 N. McCarthy Blvd., Suite 100, Milpitas, CA95035
Equipment : Touch All in one Computer
Model No. : ESY10i1B,ESY10i1C
Trade Name : Elo or **elo**
FCC ID : RBWESY10I1B

I HEREBY CERTIFY THAT :

The sample was received on Nov. 15, 2019 and the testing was completed on Dec. 27, 2019 at CerpPASS Technology Corp. The test result refers exclusively to the test presented test model / sample. Without written approval of CerpPASS Technology Corp., the test report shall not be reproduced except in full.

Approved by:

Mark Liao / Supervisor

Laboratory Accreditation:

CerpPASS Technology Corporation Test Laboratory





CONTENTS

- 1. Summary of Test Procedure and Test Results 4
 - 1.1. Applicable Standards 4
- 2. Test Configuration of Equipment under Test 5
 - 2.1. Feature of Equipment under Test..... 5
 - 2.2. Difference Description 5
 - 2.3. Description of Test System..... 5
 - 2.4. General Information of Test..... 6
 - 2.5. Measurement Uncertainty 6
- 3. Test Equipment and Ancillaries Used for Tests 7
- 4. Antenna Requirements 8
 - 4.1. Standard Applicable 8
 - 4.2. Antenna Construction and Directional Gain..... 8
- 5. Dynamic Frequency Selection 9
 - 5.1. List of Measurement and Examinations 9
 - 5.2. Test Setup 11
 - 5.3. DFS Detection Threshold 13
 - 5.4. Channel Availability Check Time 16
 - 5.5. Radar Burst at the Beginning of the Channel Availability Check Time 17
 - 5.6. Radar Burst at the End of the Channel Availability Check Time 18
 - 5.7. U-NII Detection Bandwidth 19
 - 5.8. Statistical Performance Check 20
 - 5.9. In-Service Monitoring 21
 - 5.10. Non-Occupancy Period 23
 - 5.11. EUT Setup Photos 26



1. Summary of Test Procedure and Test Results

1.1. Applicable Standards

ANSI C63.10:2013

FCC Rules and Regulations Part 15 Subpart E §15.407

KDB789033

KDB905462

FCC Rule	Description of Test	Result
15.407	Dynamic Frequency Selection	PASS

*The lab has lowered the uncertainty risk of test equipment, environment, and staff technicians according to ISO-IEC17025. Therefore we define test result as compliant when it complies with the standard without further evaluation of test result uncertainty.



2. Test Configuration of Equipment under Test

2.1. Feature of Equipment under Test

Frequency Range	802.11a/n/ac: 5260-5320MHz, 5500-5700MHz
Modulation Type	802.11a/n: BPSK, QPSK, 16QAM, 64QAM 802.11ac: BPSK, QPSK, 16QAM, 64QAM, 256QAM
Modulation Technology	OFDM
Data Rate	802.11a: 6, 9, 12, 18, 24, 36, 48, 54Mbps 802.11n: MCS0 – MCS7, HT20/40 802.11ac: MCS0 – MCS9, VHT20/40/80
Antenna Type	PCB Antenna
Adapter	Brand: DELTA Model: ADP-65JH HB INPUT: 100-240V~1.5A 50-60Hz OUTPUT: 19V / 3.42A

Note:

- 1.For a more detailed features description, please refer to the manufacturer's specifications or the User's Manual.
2. The band from 5600-5650MHz will be disabled by the software during the manufacturing and cannot be changed by the end user.
- 3.This device supports DFS client mode.

2.2. Difference Description

The differences between all model numbers as below:

Model No.	Remark
ESY10i1B	The differences between these two model numbers are for market segmentation.
ESY10i1C	

2.3. Description of Test System

DFS					
Equipment	Brand	Model	Length/Type	Power cord/Length/Type	FCC ID
Notebook	DELL	Latitude E5450	N/A	Adapter / 1.8m / NS	--
AP	NETGEAR	R7800	N/A	Adapter / 1.5m / NS	PY315100319
Network cable	N/A	N/A	1.2m / NS	N/A	--

EUT FW: SWEP_Elo_v01.051.06.a_01



2.4. General Information of Test

Test Site	Cerpass Technology Corporation Test Laboratory Address: No.10, Ln. 2, Lianfu St., Luzhu Dist., Taoyuan City 33848, Taiwan (R.O.C.) Tel:+886-3-3226-888 Fax:+886-3-3226-881	
	FCC	TW1439, TW1079
	IC	4934E-1, 4934E-2
	VCCI	T-2205 for Telecommunication test C-4663 for Conducted emission test R-4218 for Radiated emission test G-10812, G-10813 for radiated disturbance above 1GHz
Frequency Range Investigated:	Conducted: from 150kHz to 30 MHz Radiation: from 30 MHz to 40,000MHz	
Test Distance:	The test distance of radiated emission from antenna to EUT is 3 M.	

Test Item	Test Site	Finish Date	Environmental Conditions	Tested By
DFS	RFDFS01-NK	2019/11/26	25°C / 61%	Dian Chen

2.5. Measurement Uncertainty

Measurement Item	Uncertainty
Channel Move Time	±5.4%
Channel Closing Transmission Time	±6.79%
Threshold	±1.875dB



3. Test Equipment and Ancillaries Used for Tests

Test Item	DFS				
Test Site	RFDFS01-NK				
Instrument	Manufacturer	Model No	Serial No	Calibration Date	Valid Date
Horn Antenna	EMCO	3115	31589	2019/04/01	2020/03/31
Horn Antenna	EMCO	3115	31601	2019/10/07	2020/10/06
EXA Signal Analyzer	KEYSIGHT	N9010A	MY5420020 7	2019/04/12	2020/04/11
CAX Signal Analyzer	KEYSIGHT	N9000B	MY5710033 9	2019/11/25	2020/11/24
MXG Vector Signal Generator	KEYSIGHT	N5182A	MY5014155 1	2019/10/07	2020/10/06
N7607B Signal Studio	KEYSIGHT	v3.2.0.0	NA	NA	NA
InServiceMonitorUtility	Theda	v10.0.0.0	NA	NA	NA



4. Antenna Requirements

4.1. Standard Applicable

For intentional device, according to FCC 47 CFR Section 15.203, an intentional radiator shall be designed to ensure that no antenna other than that furnished by the responsible party shall be used with the device.

And according to FCC 47 CFR Section 15.407 (a), if transmitting antennas of directional gain greater than 6dBi are used, the power shall be reduced by the amount in dB that the directional gain of the antenna exceeds 6dBi.

4.2. Antenna Construction and Directional Gain

Antenna Type	PCB Antenna
Antenna Gain	5250-5350MHz: ANT A: 2.70dBi 5470-5725MHz: ANT A: 2.70dBi

5250MHz-5350MHz
For Power directional gain= $G_{ant}= 2.70 \text{ dBi}$ For PSD directional gain = $10 \log[(10^{G1/20} + 10^{G2/20} + \dots + 10^{GN/20})^2 /NANT] = 2.70 \text{ (dBi)}$
5470MHz-5725MHz
For Power directional gain= $G_{ant}= 2.70 \text{ dBi}$ For PSD directional gain = $10 \log[(10^{G1/20} + 10^{G2/20} + \dots + 10^{GN/20})^2 /NANT] = 2.70 \text{ (dBi)}$



5. Dynamic Frequency Selection

5.1. List of Measurement and Examinations

EUT Applicability of DFS requirements and Frequency Range

Operation Mode		Operating Frequency Range	
		5250-5350MHz	5470-5725MHz (5600MHz-5650MHz will be disable)
Master	--	--	--
Client without radar detection	√	√	√
Client with radar detection	--	--	--

DEVICES WITH RADAR DETECTION

MAXIMUM TRANSMIT POWER	VALUE (SEE Note 1 and 2)
≥ 200 milliwatt	-64 dBm
EIRP < 200 milliwatt and power spectral density < 10 dBm/MHz	-62 dBm
EIRP < 200 milliwatt that do not meet the power spectral density requirement	-64 dBm

Note 1: This is the level at the input of the receiver assuming a 0 dBi receive antenna.

Note 2: Throughout these test procedures an additional 1 dB has been added to the amplitude of the test transmission waveforms to account for variations in measurement equipment. This will ensure that the test signal is at or above the detection threshold level to trigger a DFS response.

Note3: EIRP is based on the highest antenna gain. For MIMO devices refer to KDB Publication 662911

Table1: Applicability of DFS requirements prior to use of a channel

Requirement	Operational Mode		
	Master	Client Without Radar Detection	Client With Radar Detection
Non-Occupancy Period	Yes	Not required	Yes
DFS Detection Threshold	Yes	Not required	Yes
Channel Availability Check Time	Yes	Not required	Not required
U-NII Detection Bandwidth	Yes	Not required	Yes

Note: Regarding KDB 905462 D03 Client Without DFS New Rules section (b)(5/6),

If the client moves with the master, the device is considered compliant if nothing appears in the client non-occupancy period test. For devices that shut down (rather than moving channels), no beacons should appear. An analyzer plot that contains a single 30-minute sweep on the original channel.



Table2: Applicability of DFS requirements during normal operation

Requirement	Operational Mode	
	Master Device or Client with Radar Detection	Client Without Radar Detection
DFS Detection Threshold	Yes	Not required
Channel Closing Transmission Time	Yes	Yes
Channel Move Time	Yes	Yes
U-NII Detection Bandwidth	Yes	Not required

Additional requirements for devices with multiple bandwidth modes	Master or Client with radar detection	Client without radar detection
U-NII Detection Bandwidth and Statistical Performance Check	All BW modes must be tested	Not required
Channel Move Time and Channel Closing Transmission Time	Test using widest BW mode available	Test using the widest BW mode available for the link
All other	Any single BW mode	Not required

Note: Frequencies selected for statistical performance check (Section 7.8.4) should include several frequencies within the radar detection bandwidth and frequencies near the edge of the radar detection bandwidth. For 802.11 devices it is suggested to select frequencies in each of the bonded 20 MHz channels and the channel center frequency.



5.2. Test Setup

Setup for Master with injection at the Master

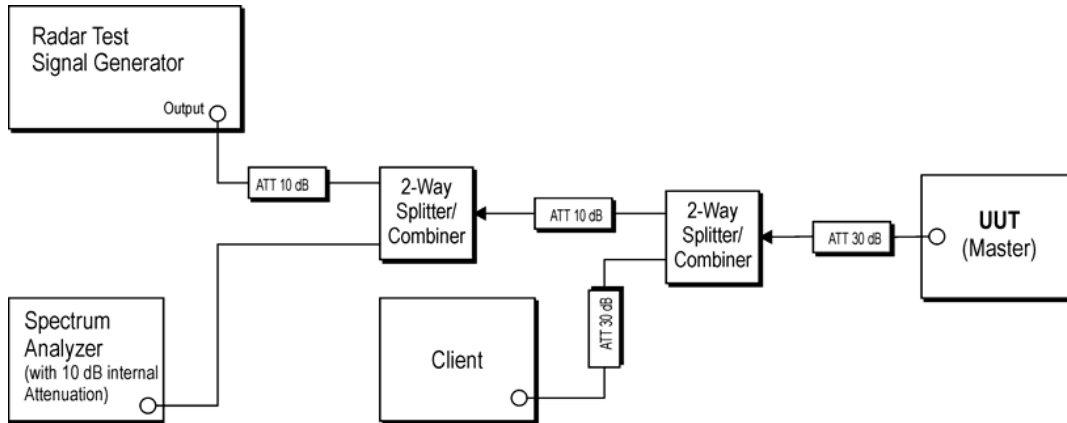

Figure 1: Example Conducted Setup where UUT is a Master and Radar Test Waveforms are injected into the Master

Setup for Client with injection at the Master

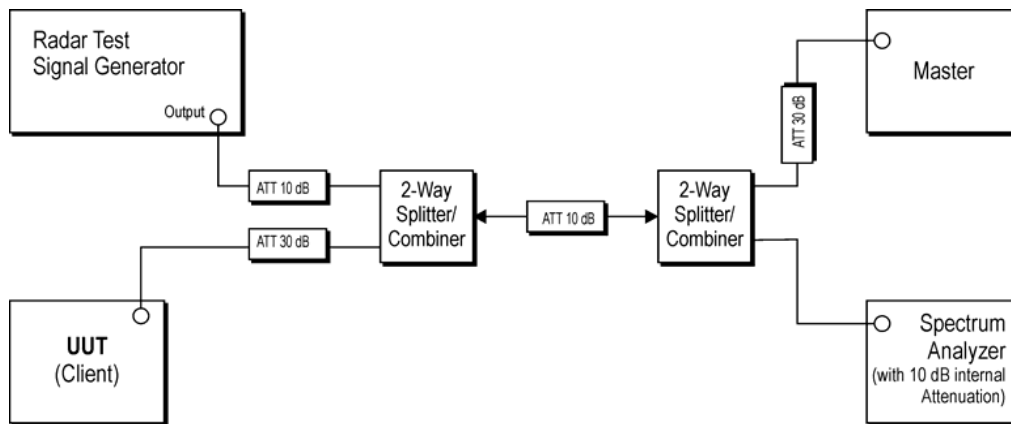

Figure 2: Example Conducted Setup where UUT is a Client and Radar Test Waveforms are injected into the Master



Setup for Client with injection at the Client

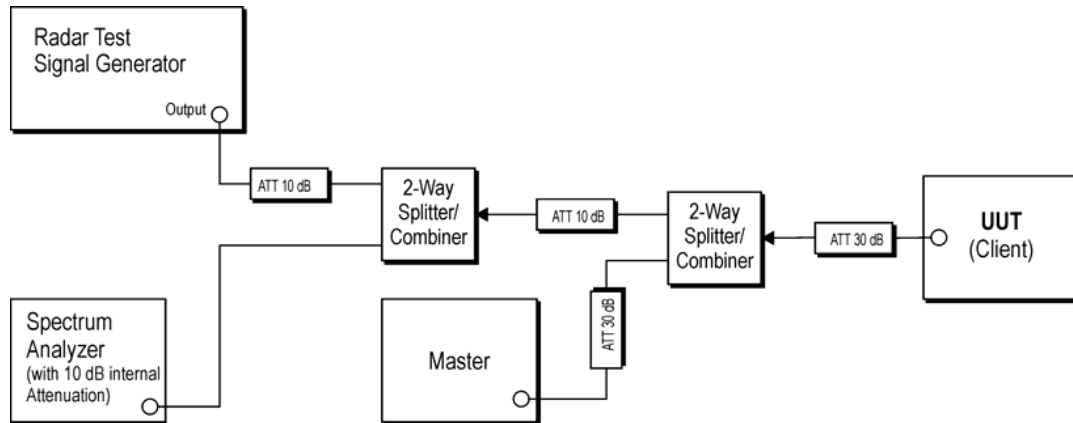

Figure 3: Example Conducted Setup where UUT is a Client and Radar Test Waveforms are injected into the Client



5.3. DFS Detection Threshold

DFS Detection Threshold is the level used by the DFS mechanism to detect radar interference.

5.3.1. Test Limit

Limits Clause 4.7.2.1.2

DFS Detection Thresholds for Master Devices and Client Devices with Radar

Detection

MAXIMUM TRANSMIT POWER	VALUE (SEE Note 1 and 2)
≥ 200 milliwatt	-64 dBm
EIRP < 200 milliwatt and power spectral density < 10 dBm/MHz	-62 dBm
EIRP < 200 milliwatt that do not meet the power spectral density requirement	-64 dBm

Note 1: This is the level at the input of the receiver assuming a 0 dBi receive antenna.

Note 2: Throughout these test procedures an additional 1 dB has been added to the amplitude of the test transmission waveforms to account for variations in measurement equipment. This will ensure that the test signal is at or above the detection threshold level to trigger a DFS response.

Note3: EIRP is based on the highest antenna gain. For MIMO devices refer to KDB Publication 662911

Max. output power	Band: 5250MHz ~ 5350MHz
	802.11a: 14.37dBm
	802.11n HT20: 14.34dBm
	802.11n HT40: 13.14dBm
	802.11ac VHT20: 14.39dBm
	802.11ac VHT40: 12.85dBm
	802.11ac VHT80: 13.23dBm
	Band: 5470MHz ~ 5725MHz
	802.11a: 13.98dBm
	802.11n HT20: 13.95dBm
	802.11n HT40: 12.52dBm
	802.11ac VHT20: 14.02dBm
	802.11ac VHT40: 12.58dBm
	802.11ac VHT80: 12.79dBm



5.3.2. Test Result of DFS Detection Threshold

Radar Type 0 Calibration Plot

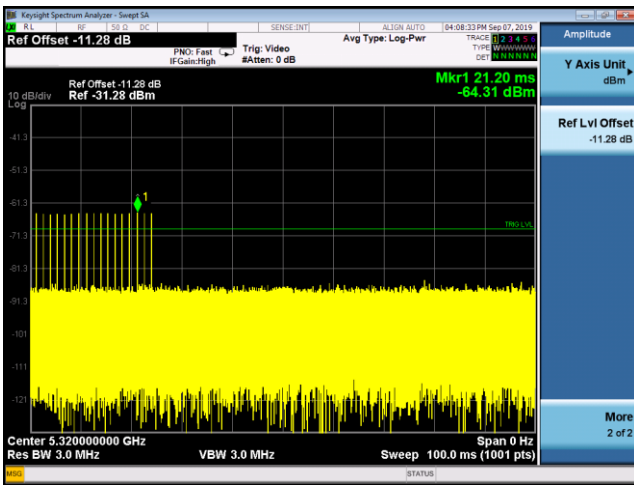

Radar Type 3 Calibration Plot

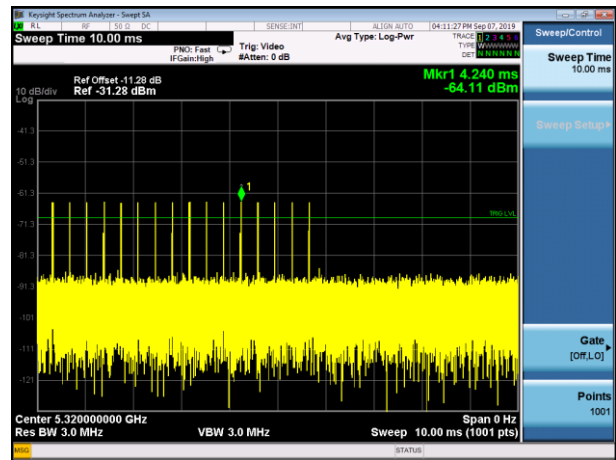

Radar Type 1 Calibration Plot

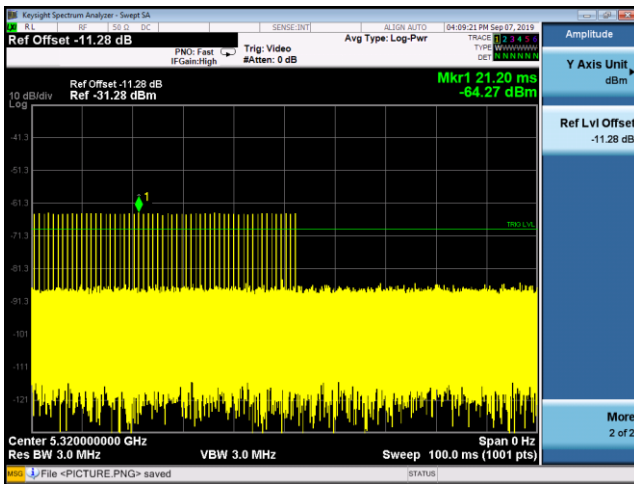

Radar Type 4 Calibration Plot

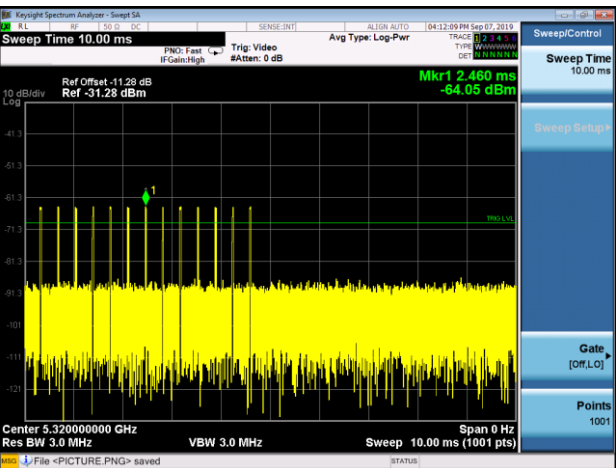

Radar Type 2 Calibration Plot

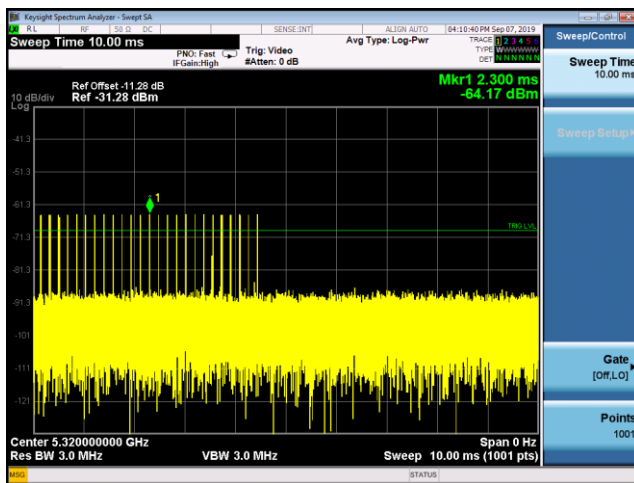

Radar Type 5 Calibration Plot

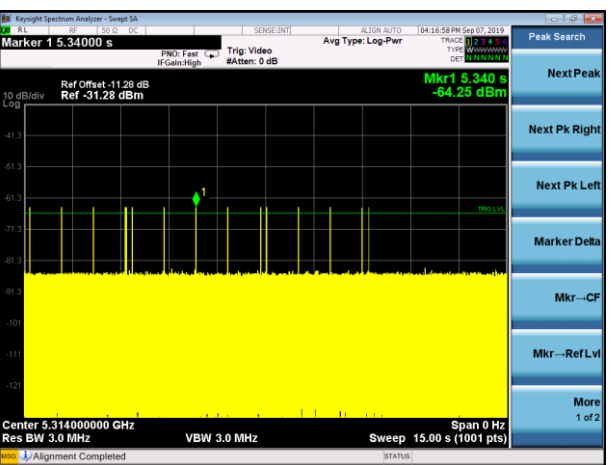



Radar Type 6 Calibration Plot

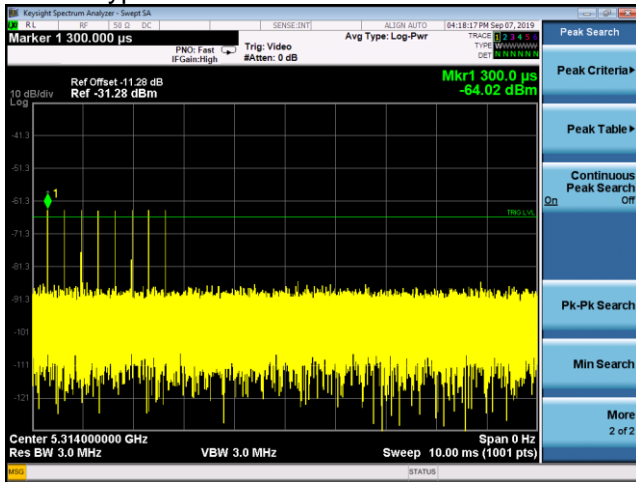



5.4. Channel Availability Check Time

The Channel Availability Check is defined as the mechanism by which an RLAN device checks a channel for the presence of radar signals.

There shall be no transmissions by the device within the channel being checked during this process.

If no radars have been detected, the channel becomes an Available Channel valid for a period of time.

The RLAN shall only start transmissions on Available Channels.

At power-up, the RLAN is assumed to have no Available Channels.

5.4.1. Test Limit

Limits Clause 4.7.2.1.2

Table D.2: DFS requirement values

Parameter	Value
Channel Availability Check	> 60s

5.4.2. Test Result of Channel Availability Check

Not required



5.5. Radar Burst at the Beginning of the Channel Availability Check Time

The steps below define the procedure to verify successful radar detection on the test Channel during a period equal to the Channel Availability Check Time and avoidance of operation on that Channel when a radar Burst with a level equal to the DFS Detection Threshold + 1 dB occurs at the beginning of the Channel Availability Check Time. This is illustrated in **Figure 15**.

- a) The Radar Waveform generator and UUT are connected using the applicable test setup described in the sections on configuration for Conducted Tests or Radiated Tests and the power of the UUT is switched off.
- b) The UUT is powered on at T_0 . T_1 denotes the instant when the UUT has completed its power-up sequence (T_{power_up}). The Channel Availability Check Time commences on Chr at instant T_1 and will end no sooner than $T_1 + T_{ch_avail_check}$.
- c) A single Burst of one of the Short Pulse Radar Types 0-4 will commence within a 6 second window starting at T_1 . An additional 1 dB is added to the radar test signal to ensure it is at or above the DFS Detection Threshold, accounting for equipment variations/errors.
- d) Visual indication or measured results on the UUT of successful detection of the radar Burst will be recorded and reported. Observation of Chr for UUT emissions will continue for 2.5 minutes after the radar Burst has been generated.
- e) Verify that during the 2.5 minute measurement window no UUT transmissions occurred on Chr. The Channel Availability Check results will be recorded.

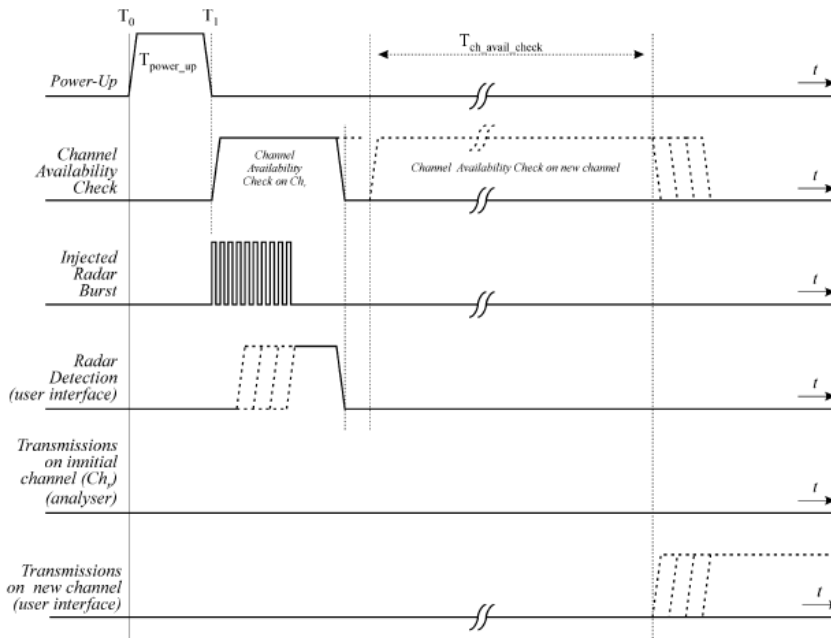

Figure 15: Example of timing for radar testing at the beginning of the Channel Availability Check Time

5.5.1. Test Result of radar burst at the beginning of the Channel Availability Check Time

Not required



5.6. Radar Burst at the End of the Channel Availability Check Time

The steps below define the procedure to verify successful radar detection on the test Channel during a period equal to the Channel Availability Check Time and avoidance of operation on that Channel when a radar Burst with a level equal to the DFS Detection Threshold + 1dB occurs at the end of the Channel Availability Check Time. This is illustrated in **Figure 16**.

- a) The Radar Waveform generator and UUT are connected using the applicable test setup described in the sections for Conducted Tests or Radiated Tests and the power of the UUT is switched off.
- b) The UUT is powered on at T_0 . T_1 denotes the instant when the UUT has completed its power-up sequence (T_{power_up}). The Channel Availability Check Time commences on Chr at instant T_1 and will end no sooner than $T_1 + T_{ch_avail_check}$.
- c) A single Burst of one of the Short Pulse Radar Types 0-4 will commence within a 6 second window starting at $T_1 + 54$ seconds. An additional 1 dB is added to the radar test signal to ensure it is at or above the DFS Detection Threshold, accounting for equipment variations/errors.
- d) Visual indication or measured results on the UUT of successful detection of the radar Burst will be recorded and reported. Observation of Chr for UUT emissions will continue for 2.5 minutes after the radar Burst has been generated.
- e) Verify that during the 2.5 minute measurement window no UUT transmissions occurred on Chr. The Channel Availability Check results will be recorded.

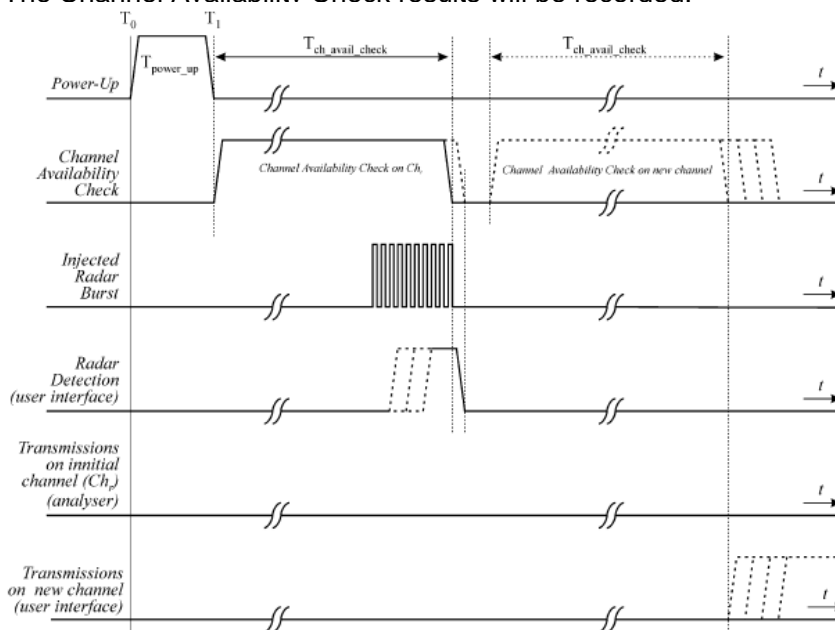

Figure 16: Example of timing for radar testing towards the end of the Channel Availability Check Time

5.6.1. Test Result of radar burst at the end of the Channel Availability Check Time

Not required



5.7. U-NII Detection Bandwidth

Additional requirements for devices with multiple bandwidth modes	Master or Client with radar detection	Client without radar detection
U-NII Detection Bandwidth and Statistical Performance Check	All BW modes must be tested	Not required
Note: Frequencies selected for statistical performance check (Section 7.8.4) should include several frequencies within the radar detection bandwidth and frequencies near the edge of the radar detection bandwidth. For 802.11 devices it is suggested to select frequencies in each of the bonded 20 MHz channels and the channel center frequency.		

5.7.1. Test Limit

Limits Clause 4.7.2.1.2 Table D.2: DFS requirement values

Parameter	Value
U-NII Detection Bandwidth	Minimum 100% of the U-NII 99% transmission
Note : During the U-NII Detection Bandwidth detection test, radar type 0 should be used. For each frequency step the minimum percentage of detection is 90 percent. Measurements are performed with no data traffic.	

5.7.2. Test Result of U-NII Detection Bandwidth

Not required



5.8. Statistical Performance Check

The UUT will select channel by random mode and remember this channel when detect radar signal, so that will select unused channel by random mode.

5.8.1. Test Result of Uniform Spreading

Not required



5.9. In-Service Monitoring

The In-Service Monitoring is defined as the process by which an RLAN monitors the Operating Channel for the presence of radar signals.

Additional requirements for devices with multiple bandwidth modes	Master or Client with radar detection	Client without radar detection
U-NII Detection Bandwidth and Statistical Performance Check	All BW modes must be tested	Not required
Channel Move Time and Channel Closing Transmission Time	Test using widest BW mode available	Test using the widest BW mode available for the link
All other	Any single BW mode	Not required
Note: Frequencies selected for statistical performance check (Section 7.8.4) should include several frequencies within the radar detection bandwidth and frequencies near the edge of the radar detection bandwidth. For 802.11 devices it is suggested to select frequencies in each of the bonded 20 MHz channels and the channel center frequency.		

5.9.1. Test Limit

Parameter	Value
Channel Move Time	< 10 s (See Note 1)
Channel Closing Transmission Time	< 200 ms+ an aggregate of 60 milliseconds over remaining 10 second period. (See Notes 1 and Notes 2.)
<p>Note 1: Channel Move Time and the Channel Closing Transmission Time should be performed with Radar Type 0. The measurement timing begins at the end of the Radar Type 0 burst.</p> <p>Note 2: The Channel Closing Transmission Time is comprised of 200 milliseconds starting at the beginning of the Channel Move Time plus any additional intermittent control signals required to facilitate a Channel move (an aggregate of 60 milliseconds) during the remainder of the 10 second period. The aggregate duration of control signals will not count quiet periods in between transmissions.</p>	

Limits Clause 4.7.2.2.2

The In-Service Monitoring shall be used to continuously monitor an Operating Channel.

The In-Service-Monitoring shall start immediately after the RLAN has started transmissions on an Operating Channel.



5.9.2. Test Result of In-Service Monitoring

Modulation Standard: 802.11ac VHT80, 5290MHz

Modulation Standard: 802.11ac VHT80, 5530MHz

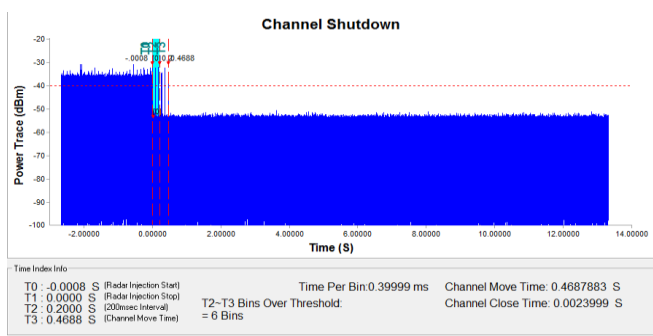
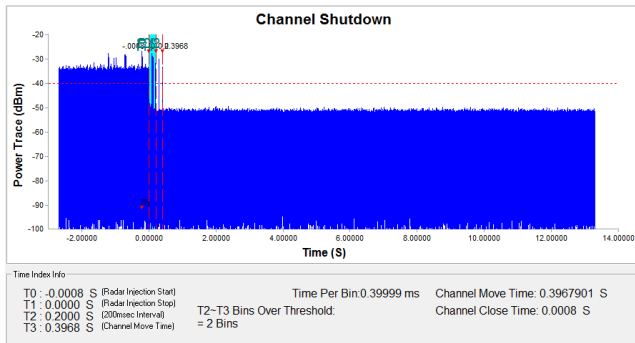



5.10. Non-Occupancy Period

The Channel Shutdown is defined as the process initiated by the RLAN device immediately after a radar signal has been detected on an Operating Channel.

The master device shall instruct all associated slave devices to stop transmitting on this channel, which they shall do within the Channel Move Time.

Slave devices with a Radar Interference Detection function, shall stop their own transmissions within the Channel Move Time.

The aggregate duration of all transmissions of the RLAN device on this channel during the Channel Move Time shall be limited to the Channel Closing Transmission Time. The aggregate duration of all transmissions shall not include quiet periods in between transmissions.

5.10.1. Test Limit

Radar Test Signal	Master (min)	Client (min)
0	> 30	> 30

5.10.2. Channel Loading

Timing plots are required with calculations demonstrating a minimum channel loading of approximately 17% or greater. For example, channel loading can be estimated by setting the spectrum analyzer for zero span and approximate the Time On/ (Time On + Off Time). This can be done with any appropriate channel BW and modulation type



Modulation Standard: 802.11ac VHT80, 5290MHz
Channel Load 17.67%

Modulation Standard: 802.11ac VHT80, 5530MHz
Channel Load 17.87%

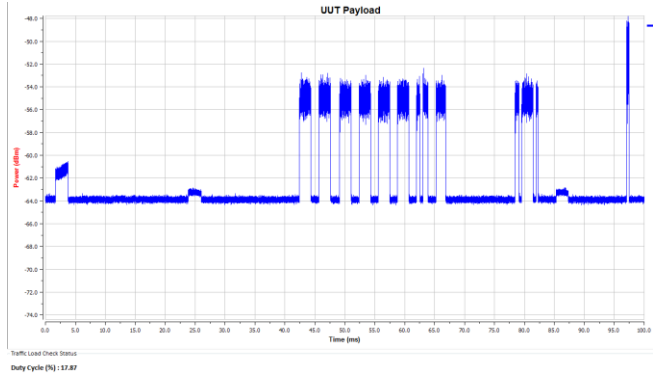
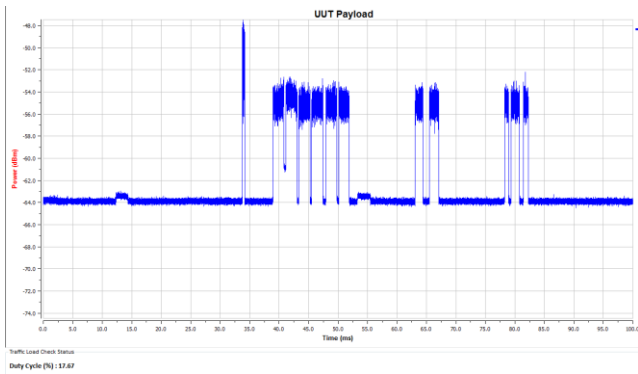



5.10.3. Test Result of Non-Occupancy Period

Not required



5.11. EUT Setup Photos

