



FCC TEST REPORT

According to

CFR47 §15.407/RSS-247 Issue 2

Applicant : Elo Touch Solutions, Inc
Address : 670 N. McCarthy Blvd., Suite 100, Milpitas, CA95035
Manufacturer : Elo Touch Solutions, Inc.
Address : 670 N. McCarthy Blvd., Suite 100, Milpitas, CA95035
Equipment : Touch All in one Computer
Model No. : ESY10I1B, ESY10I1C
FCC ID : RBWESY10I1B
IC ID : 10757B-ESY10I1B
Test Period : Sept.03,2017~ Sept.18, 2017

- The test result refers exclusively to the test presented test model / sample.
- Without written approval of **Cerpess Technology Corporation Test Laboratory**, the test report shall not be reproduced except in full.
- The test report must not be used by the clients to claim product certification approval by **NVLAP** or any agency of the Government.

I HEREBY CERTIFY THAT :

The measurements shown in this test report were made in accordance with the procedures given in **ANSI C63.10 – 2013&RSS-247,Issue 2&RSS-Gen&FCC Part15.407**and the energy emitted by this equipment was **passed**.

Approved by:

Laboratory Accreditation:

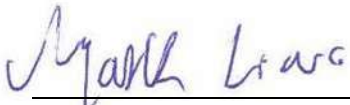

 Mark Liao / Assistant Manager



Cerpess Technology Corporation Test Laboratory

TAF LAB Code:

1439



TABLE OF CONTENTS

1. Test Configuration of Equipment under Test	5
1.1 Feature of Equipment under Test	5
1.2 Description of Antenna	5
1.3 Working Frequencies.....	6
1.4 The Worst Case Configuration	7
1.5 Power Parameter Value of the test software	8
1.6 Duty Cycle	9
1.7 Test Manner.....	10
1.8 Support equipment	11
2. Technical Test	12
2.1 Summary of Test Result	12
2.2 General Information of Test	13
2.3 Measuring Equipment	14
2.4 Measurement Uncertainty	15
3. Test of Conducted Emission	16
3.1 Test Limit	16
3.2 Test Standard.....	16
3.3 Test Procedures.....	16
3.4 Test Setup.....	17
3.5 Test Result and Data	18
4. Test of Radiated Emission	20
4.1 Test Limit	20
4.2 Test Standard	20
4.3 Test Procedures	21
4.4 Test Setup	22
4.5 Test Result and Data	24
5. 26dB Occupied Bandwidth	32
5.1 Test Limit	32
5.2 Test Standard.....	32
5.3 Test Procedures.....	33
5.4 Test Setup.....	34
5.5 Test Result and Data	35
6. 6dB Bandwidth Measurement	41
6.1 Test Limit	41
6.2 Test Standard.....	41
6.3 Test Procedures.....	41
6.4 Test Setup	41
6.5 Test Result and Data	42
7. Power Output	46
7.1 Test Limit	46
7.2 Test Standard.....	46



7.3 Test Procedures..... 47

7.4 Test Setup..... 47

7.5 Test Result and Data 48

8. Power Spectral Density..... 51

8.1 Test Limit 51

8.2 Test Standard..... 51

8.3 Test Procedures..... 52

8.4 Test Setup..... 52

8.5 Test Result and Data 53

9. Band Edges Measurement..... 58

9.1 Test Limit 58

9.2 Test Standard..... 60

9.3 Test Procedures..... 60

9.4 Test Setup..... 61

9.5 Test Result and Data 62

10. Frequency Stability..... 104

10.1 Test Limit 104

10.2 Test Standard..... 104

10.3 Test Procedures..... 104

10.4 Test Setup..... 105

10.5 Test Result and Data 106



History of this test report

Report No.	Version	Issue Date	Description
TEDL1707267-A	Rev.01	2017-09-21	Initial release



1. Test Configuration of Equipment under Test

1.1 Feature of Equipment under Test

Product Name	Touch All in one Computer
Model No.	ESY10I1B, ESY10I1C (two models were identical except for marketing purpose)
wireless Model No.	WIFI-2-R811USA2
Frequency Range	802.11a/n (20MHz): 5180~5250MHz, 5725~5850MHz 802.11n(40MHz): 5190~5230MHz, 5755~5795MHz 802.11ac(80MHz): 5210MHz,5775MHz
Type of Modulation	802.11a/g/n/ac: OFDM
Data Rate	802.11a: 6/9/12/18/24/36/48/54 Mbps 802.11ac: up to 433.3 Mbps
Channel Control	Auto
Antenna Delivery	1*Tx + 1*Rx for 5GHz

1.2 Description of Antenna

Model	Antenna	Peak Gain
ESY10I1B, ESY10I1C	PCB Antenna	2.92dBi for 2.4~2.4835GHz band 2.67dBi for 5.15~5.25GHz band 2.64dBi for 5.725~5.85GHz band
ESY15I1B, ESY15I1C	PCB Antenna	2.68dBi for 2.4~2.4835GHz band 2.50dBi for 5.15~5.25GHz band 2.54dBi for 5.725~5.85GHz band
ESY22I1B	PCB Antenna	2.68dBi for 2.4~2.4835GHz band 2.50dBi for 5.15~5.25GHz band 2.54dBi for 5.725~5.85GHz band

Note: We choose the maximum peak gain (ESY10I1B) for final test of each channel shown as the table.



1.3 Working Frequencies

802.11a/n(20MHz) Working Frequency of Each Channel:							
Channel	Frequency	Channel	Frequency	Channel	Frequency	Channel	Frequency
36	5180 MHz	40	5200 MHz	44	5220 MHz	48	5240 MHz
149	5745 MHz	153	5765 MHz	157	5785 MHz	161	5805 MHz
165	5825 MHz	N/A	N/A	N/A	N/A	N/A	N/A
802.11n(40MHz) Working Frequency of Each Channel:							
Channel	Frequency	Channel	Frequency	Channel	Frequency	Channel	Frequency
38	5190 MHz	46	5230 MHz	151	5755 MHz	159	5795 MHz
802.11ac(80MHz) Working Frequency of Each Channel:							
Channel	Frequency	Channel	Frequency	Channel	Frequency	Channel	Frequency
42	5210 MHz	155	5775 MHz	N/A	N/A	N/A	N/A



1.4 The Worst Case Configuration

Data rate Configuration:

Modulation Mode	Test Channel	Data Rate	Average Power(dBm)
802.11a	36	6Mbps	11.87
		18Mbps	11.66
		54Mbps	11.69
802.11n(HT20)	36	Msc0	11.78
		Msc3	11.64
		Msc7	11.71
802.11n(HT40)	38	Msc0	8.94
		Msc3	8.74
		Msc7	8.87
802.11ac(VHT80)	42	Msc0	8.04
		Msc3	7.96
		Msc7	8.01

Modulation Mode	Worst Data Rate
802.11a	6Mbps
802.11n(HT20)	MCS0
802.11n(HT40)	MCS0
802.11ac(VHT80)	MCS0

Note: 1. Power output test was verified over all data rates of each mode, and then choose the maximum power output for final test of each channel shown as the table.

2. EUT is put X,Y,Z three axial assessment test,and Y axial is the worst case,so the EUT is put Y axial for all RF items tested.

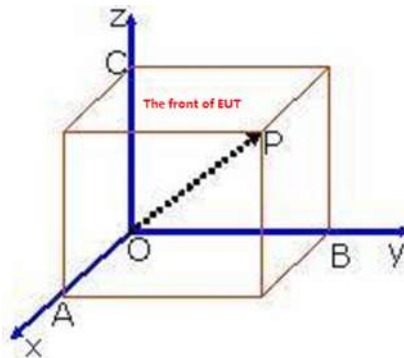



1.5 Power Parameter Value of the test software

Test Mode	Test Channel	Power Setting
802.11a	5180	15
	5220	15
	5240	15
	5745	15
	5785	15
	5825	15
802.11n(20MHz)	5180	15
	5220	15
	5240	15
	5745	14
	5785	14
	5825	14
802.11n(40MHz)	5190	15
	5230	15
	5755	13.5
	5795	13.5
802.11ac(80MHz)	5210	15
	5775	15



1.6 Duty Cycle

Test Mode	Frequency (MHz)	Duty Cycle
802.11a	5180	86.51
802.11ac(20MHz)	5180	86.02
802.11ac(40MHz)	5190	72.46
802.11ac(80MHz)	5210	55.36

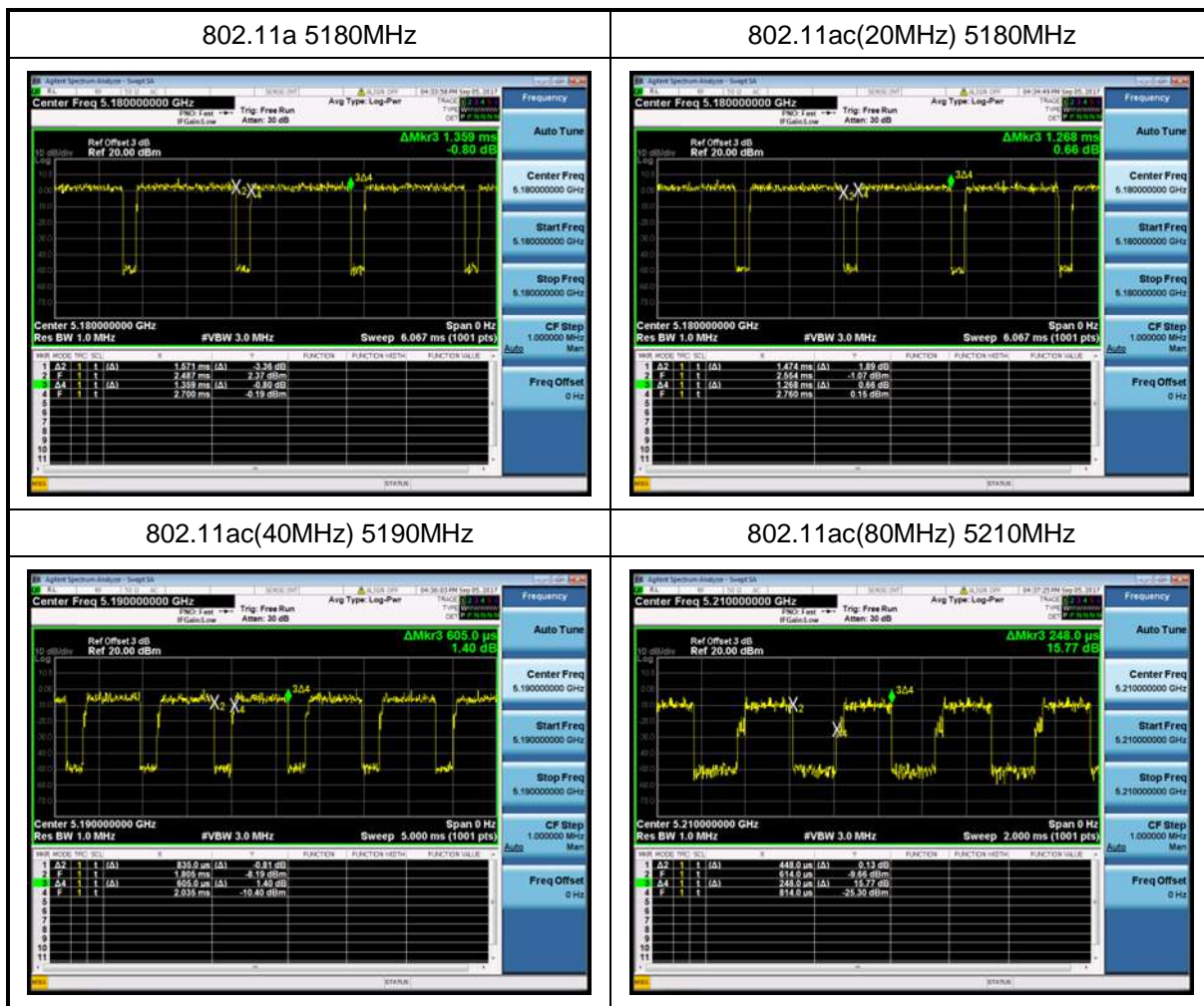



1.7 Test Manner

Test Manner	
a	Turn on the power of equipment.
b	Run 'QRCT', input RF test command and set the test mode and channel, then press Transmit to start continue transmit.



1.8 Support equipment

Product	Manufacturer	Model No.	Serial No.
1 Barcode Scanner	Elo Touch Solutions, Inc.	KIT,BCR,USB, AAiO/02 Series	E093433
2 Barcode Scanner	Elo Touch Solutions, Inc.	KIT,FPR,USB,ESY X-Series	E001001
3 NFC	Elo Touch Solutions, Inc.	KIT,NFC,USB, ESY X Series/AAiO/02 Series	E001004
4 Barcode Scanner	Elo Touch Solutions, Inc.	ELOKIT, 2DBCR, USB, ESYELO-RGEN	E926356
5 HDD	HGST	HTS721010A9E630	N/A
6 Router	Zyxel	P-660HNU-T1	R33011

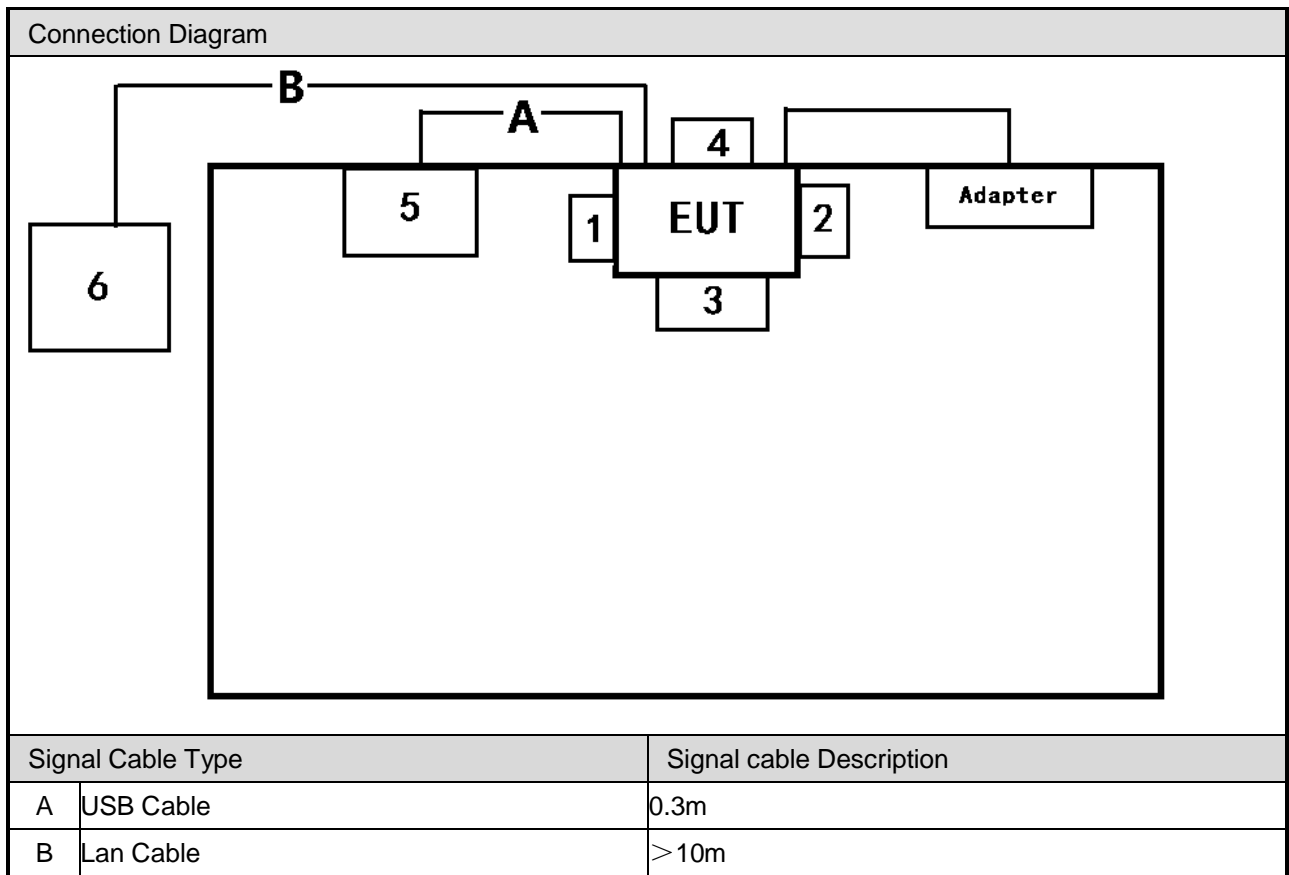



2. Technical Test

2.1 Summary of Test Result

No deviations from the test standards

Deviations from the test standards as below description:

FCC15.407/RSS-247, Issue 2 Section(s)	Test Description	Test Result	Reference
FCC 15.407(a)	26dB Bandwidth	Pass	Section 7.2
FCC 15.407(e) RSS-247 Issue 2 February 2017 Section 6.2.4.1	6dB Bandwidth	Pass	Section 7.3
FCC 15.407(h)(1) RSS-247 Issue 2 February 2017 Section 6.2.1.1& 6.2.2.1&6.2.3.1&6.2.4.1	Maximum Conducted Output Power	Pass	Section 7.4
FCC 15.407 (h)(1) RSS-247 Issue 2 February 2017 Section 6.2.1.1& 6.2.2.1&6.2.3.1&6.2.4.1	Transmit Power Control	N/A	Section 7.5
FCC 15.407(a)(1)(ii), (2), (3), (5) RSS-247 Issue 2 February 2017 Section 6.2.1.1& 6.2.2.1&6.2.3.1&6.2.4.1	Peak Power Spectral Density	Pass	Section 7.6
FCC 15.407(g) RSS-GEN Issue 4 Section 6.11	Frequency Stability	Pass	Section 7.7
15.407(b)(1), (2), (3), (4)	Undesirable Emissions	Pass	Section 7.8 & 7.9
FCC 15.205, 15.209 15.407(b)(5), (6), (7) RSS-247 Issue 2 February 2017 Section 6.2.1.2& 6.2.2.2&6.2.3.2&6.2.4.2	General Field Strength Limits (Restricted Bands and Radiated Emission Limits)	Pass	Section 7.8 & 7.9
FCC 15.207 RSS-Gen Issue 4 November 2014 Section 8.8	AC Conducted Emissions 150kHz - 30MHz	Pass	Section 7.10



2.2 General Information of Test

Test Site :	Cerpess Technology Corporation Test Laboratory Location: No.68-1,Shibachong Xi,Shiding Dist,New Taipei City <u>Tel:+886-3-3226-888</u> <u>Fax:+886-3-3226-881</u>
FCC Registration Number :	TW1439
IC Registration Number :	4934B-1
VCCI	T-2205 for Telecommunication Test C-4663 for Conducted emission test R-4399, R-4218 for Radiated emission test G-812, G-813 for radiated disturbance above 1GHz



2.3 Measuring Equipment

Instrument/Ancillary	Manufacturer	Model No.	Serial No.	Calibration Date	Valid Date.
Test Receiver	R&S	ESCI	100565	2017.03.26	2018.03.25
AMN	R&S	ESH2-Z5	100182	2017.09.06	2018.09.05
Two-Line V-Network	R&S	ENV216	100325	/	/
Pulse Limiter	R&S	ESH3-Z2	100529	2017.03.26	2018.03.25
Temperature/ Humidity Meter	Zhicheng	ZC1-11	CEP-TH-004	2017.03.29	2018.03.28
EZ-EMC	Fala	Ver CT3A1	N/A	N/A	N/A

Instrument/Ancillary	Manufacturer	Model No.	Serial No.	Calibration Date	Valid Date.
EMI Test Receiver	R&S	ESCI	101183	2017.03.26	2018.03.25
Preamplifier	songyi	EM330	60618	2017.03.26	2018.03.25
Preamplifier	Agilent	8449B	3008A02342	2017.03.26	2018.03.25
Bilog Antenna	Sunol Science	JB1	A072414-1	2017.04.16	2018.04.15
Broad-Band Horn Antenna	Schwarzbeck	BBHA9120D	9120D-618	2017.04.16	2018.04.15
Broad-Band Horn Antenna	Schwarzbeck	BBHA9170	9170-347	2017.04.16	2018.04.15
Preamplifier	COM-POWER	PA-840	711885	2017.03.26	2018.03.25
Spectrum Analyzer	R&S	FSP40	100324	2017.03.26	2018.03.25
Spectrum Analyzer	KEYSIGHT	N9010A	MY54200207	2017.03.17	2018.03.16
Temperature/ Humidity Meter	Zhicheng	ZC1-11	CEP-TH-002	2017.03.29	2018.03.28
EZ-EMC	Fala	Ver CT3A1	N/A	N/A	N/A



2.4 Measurement Uncertainty

ISO/IEC 17025 requires that an estimate of the measurement uncertainties associated with the emissions test results be included in the report. The measurement uncertainties given below are based on a 95% confidence level (based on a coverage factor (k=2)).

Measurement Item	Measurement Frequency	Polarization	Uncertainty
Conducted Emission	9 kHz ~ 30 MHz	Line / Neutral	±2.9076 dB
Radiated Emission	9 kHz ~ 40,000 MHz	Vertical / Horizontal	±0.948 dB
Spurious Emission (Conducted)	-	-	±4.011 dB
Maximum Peak and Average Output Power	-	-	±0.322 dB
Power Spectral Density	-	-	±0.322 dB
Bandwidth	-	-	74.224Hz



3. Test of Conducted Emission

3.1 Test Limit

Conducted Emissions were measured from 150 kHz to 30 MHz with a bandwidth of 9 KHz on the 120 VAC power and return leads of the EUT according to the methods defined in ANSI C63.10-2013 Section 6.2. The EUT was placed on a nonmetallic stand in a shielded room 0.8 meters above the ground plane as shown in section 6.2.2. The interface cables and equipment positioning were varied within limits of reasonable applications to determine the position produced maximum conducted emissions.

Frequency (MHz)	Quasi Peak (dB μ V)	AVG (dB μ V)
0.15 – 0.5	66-56*	56-46*
0.5 – 5.0	56	46
5.0 – 30.0	60	50

*Decreases with the logarithm of the frequency.

3.2 Test Standard

ANSI C63.10: 2013 Section 6.2.

3.3 Test Procedures

The EUT was placed on a platform of nominal size, 1 m by 1.5 m, raised 80 cm above the conducting ground plane. The vertical conducting plane was located 40 cm to the rear of the EUT. All other surfaces of EUT were at least 80 cm from any other grounded conducting surface. The EUT and simulators are connected to the main power through a line impedance stabilization network (LISN). The LISN provides a 50 ohm /50uH coupling impedance for the measuring equipment. The peripheral devices are also connected to the main power through a LISN. (Please refer to the block diagram of the test setup and photographs) Each current-carrying conductor of the EUT power cord, except the ground (safety) conductor, was individually connected through a LISN to the input power source.

The excess length of the power cord between the EUT and the LISN receptacle were folded back and forth at the center of the lead to form a bundle not exceeding 40 cm in length.

Conducted emissions were investigated over the frequency range from 0.15MHz to 30MHz using a receiver bandwidth of 9 kHz.



3.4 Test Setup

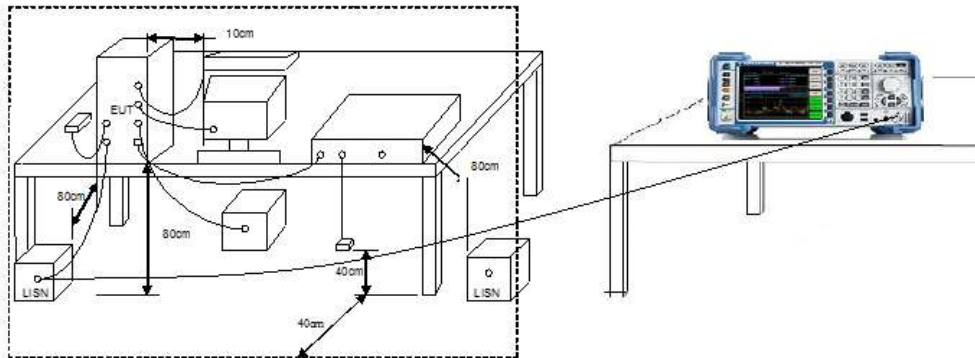



3.5 Test Result and Data

Test Mode :	Mode 1: Normal Operation with wifi on		
AC Power :	AC 120V/60Hz	Phase :	LINE
Temperature :	26°C	Humidity :	60%
Pressure(mbar) :	1002	Date:	2017/09/11

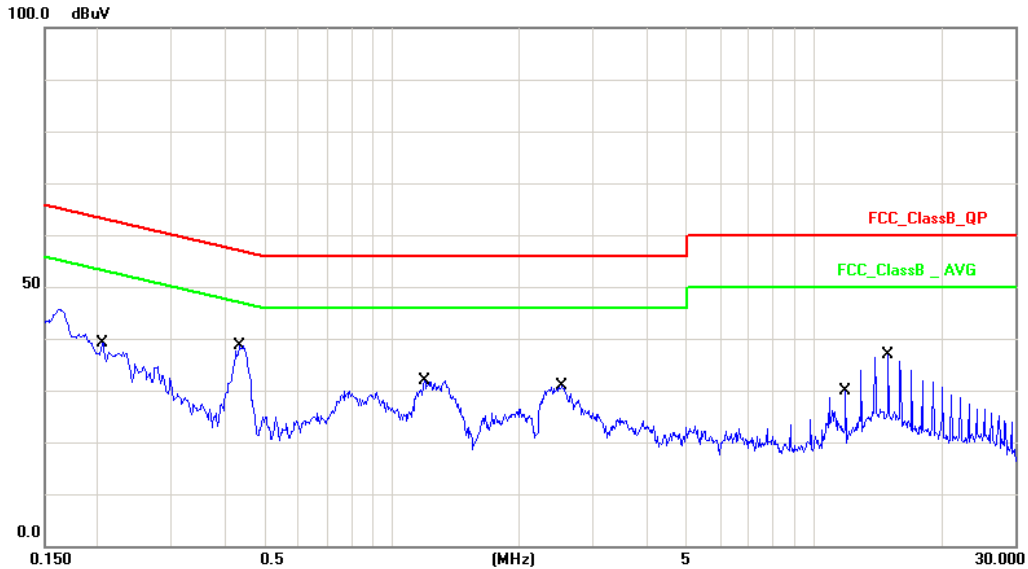

No.	Frequency (MHz)	Factor (dB)	Reading (dBuV)	Level (dBuV)	Limit (dBuV)	Margin (dB)	Detector
1	0.2060	10.12	22.10	32.22	63.36	-31.14	QP
2	0.2060	10.12	4.17	14.29	53.36	-39.07	AVG
3	0.4340	10.15	24.78	34.93	57.18	-22.25	QP
4	0.4340	10.15	17.50	27.65	47.18	-19.53	AVG
5	1.1940	10.16	15.83	25.99	56.00	-30.01	QP
6	1.1940	10.16	10.74	20.90	46.00	-25.10	AVG
7	2.5380	10.18	13.65	23.83	56.00	-32.17	QP
8	2.5380	10.18	7.67	17.85	46.00	-28.15	AVG
9	11.9060	10.35	18.28	28.63	60.00	-31.37	QP
10	11.9060	10.35	15.88	26.23	50.00	-23.77	AVG
11	15.0100	10.53	23.90	34.43	60.00	-25.57	QP
12	15.0100	10.53	20.68	31.21	50.00	-18.79	AVG

Note: Measurement Level = Reading Level + Correct Factor



Test Mode :	Mode 1: Normal Operation with wifi on		
AC Power :	AC 120V/60Hz	Phase :	NEUTRAL
Temperature :	26°C	Humidity :	60%
Pressure(mbar) :	1002	Date:	2017/09/11

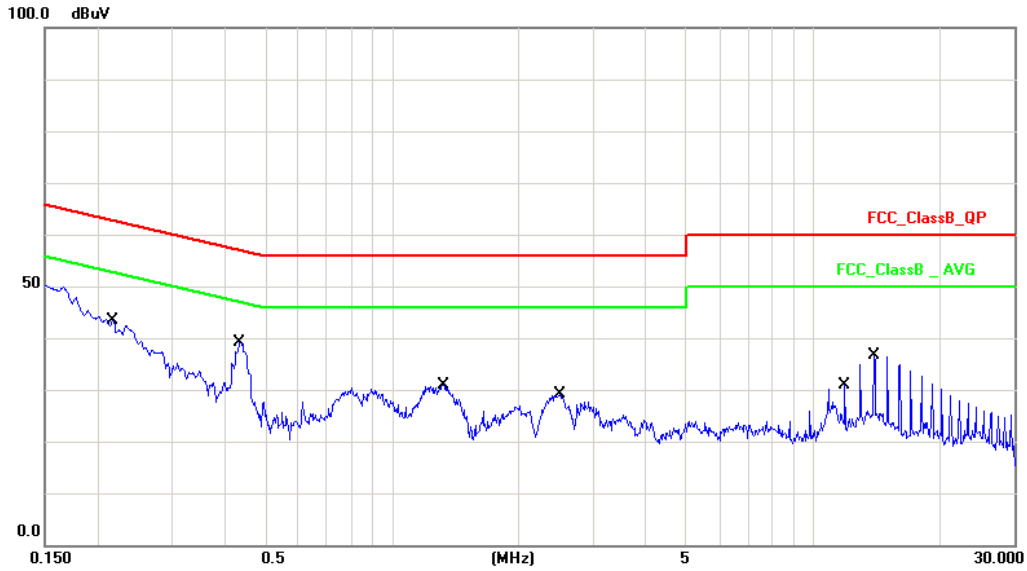

No.	Frequency (MHz)	Factor (dB)	Reading (dBuV)	Level (dBuV)	Limit (dBuV)	Margin (dB)	Detector
1	0.2180	10.13	24.13	34.26	62.89	-28.63	QP
2	0.2180	10.13	5.58	15.71	52.89	-37.18	AVG
3	0.4340	10.15	25.04	35.19	57.18	-21.99	QP
4	0.4340	10.15	17.78	27.93	47.18	-19.25	AVG
5	1.3260	10.18	16.69	26.87	56.00	-29.13	QP
6	1.3260	10.18	10.95	21.13	46.00	-24.87	AVG
7	2.5059	10.19	14.23	24.42	56.00	-31.58	QP
8	2.5059	10.19	8.50	18.69	46.00	-27.31	AVG
9	11.9100	10.36	18.72	29.08	60.00	-30.92	QP
10	11.9100	10.36	16.59	26.95	50.00	-23.05	AVG
11	13.9780	10.48	23.50	33.98	60.00	-26.02	QP
12	13.9780	10.48	19.25	29.73	50.00	-20.27	AVG

Note: Measurement Level = Reading Level + Correct Factor



4. Test of Radiated Emission

4.1 Test Limit

According to §15.209(a), except as provided elsewhere in this Subpart, the emissions from an intentional radiator shall not exceed the field strength levels specified in the following table:

FCC Part 15 Subpart C Paragraph 15.209		
FREQUENCIES (MHz)	FIELD STRENGTH (micro volts/meter)	MEASUREMENT DISTANCE (meters)
0.009~0.490	2400/F(kHz)	300
0.490~1.705	24000/F(kHz)	30
1.705~30.0	30	30
30~88	100	3
88~216	150	3
216~960	200	3
Above 960	500	3

Note 1: The lower limit shall apply at the transition frequency.

Note 2: Distance refers to the distance in meters between the measuring instrument Antenna and the closed point of any part of the device or system.

Note 3: E field strength (dBuV/m) = 20 log E field strength (uV/m)

Note 4: **Except as provided in paragraph (g), fundamental emissions from intentional radiators operating under this section shall not be located in the frequency bands 54-72 MHz, 76-88 MHz, 174-216 MHz or 470-806 MHz. However, operation within these frequency bands is permitted under other sections of this part, e.g., §§15.231 and 15.241.

4.2 Test Standard

KDB 789033 D02v01r04 – Section G



4.3 Test Procedures

Quasi-Peak Field Strength Measurements:

1. Analyzer center frequency was set to the frequency of the radiated spurious emission of interest
2. Span was set greater than 1MHz
3. RBW = 120 kHz
4. Detector = CISPR quasi-peak
5. Sweep time = auto couple
6. Trace was allowed to stabilize

Peak Field Strength Measurements:

1. Analyzer center frequency was set to the frequency of the radiated spurious emission of interest
2. RBW = 1MHz
3. VBW = 3MHz
4. Detector = peak
5. Sweep time = auto couple
6. Trace mode = max hold
7. Trace was allowed to stabilize

AVE Field Strength Measurements:

1. Analyzer center frequency was set to the frequency of the radiated spurious emission of interest
2. RBW = 1MHz
3. VBW = 3MHz
4. Detector = power average (Average)
5. Number of measurement points = 1001 (Number of points must be $> 2 \times \text{span}/\text{RBW}$)
6. Sweep time = auto
7. Trace was averaged over at 100 sweeps



4.4 Test Setup

9kHz~30MHz Test Setup

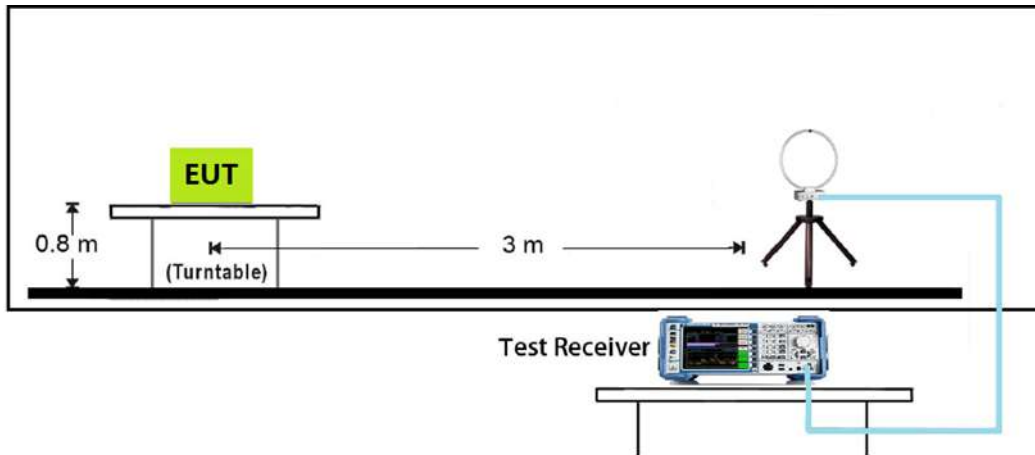



Below 1GHz Test Setup

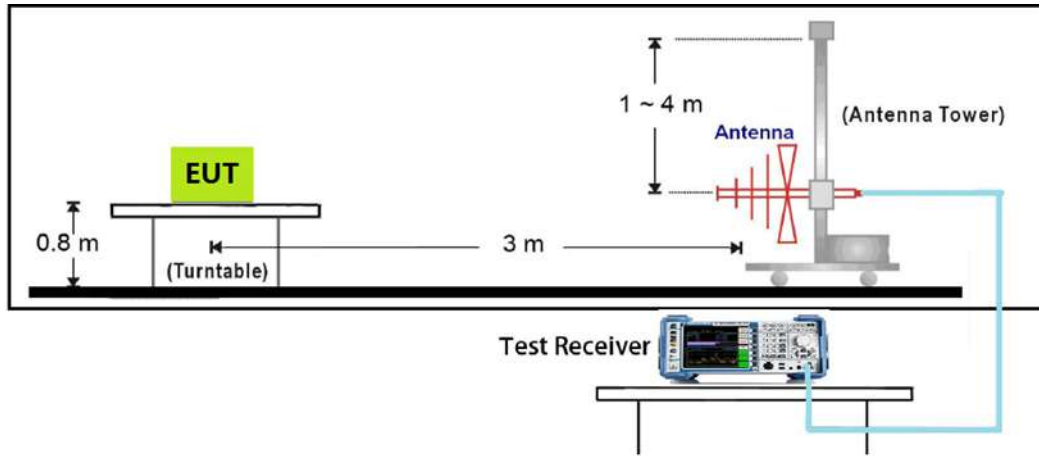

1GHz~18GHz Test Setup

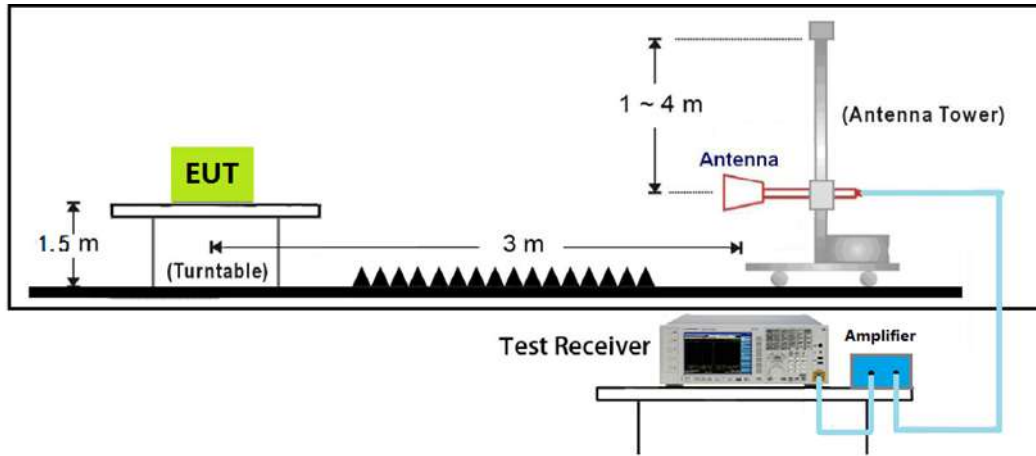

18GHz~40GHz Test Setup

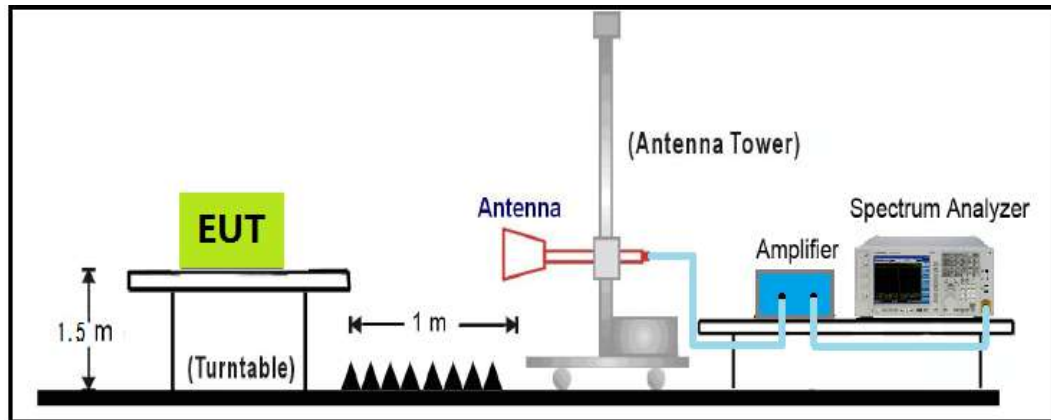



4.5 Test Result and Data

The worst case of Radiated Emission below 1GHz:

Limit: FCC_Part15.209_RE(3m)	Margin: 0
Probe: N/A	Polarity: Horizontal
EUT: Touch All in one Computer	Power: AC 120V/60Hz
Note: Mode1: Transmit at channel 5220MHz by 802.11a	

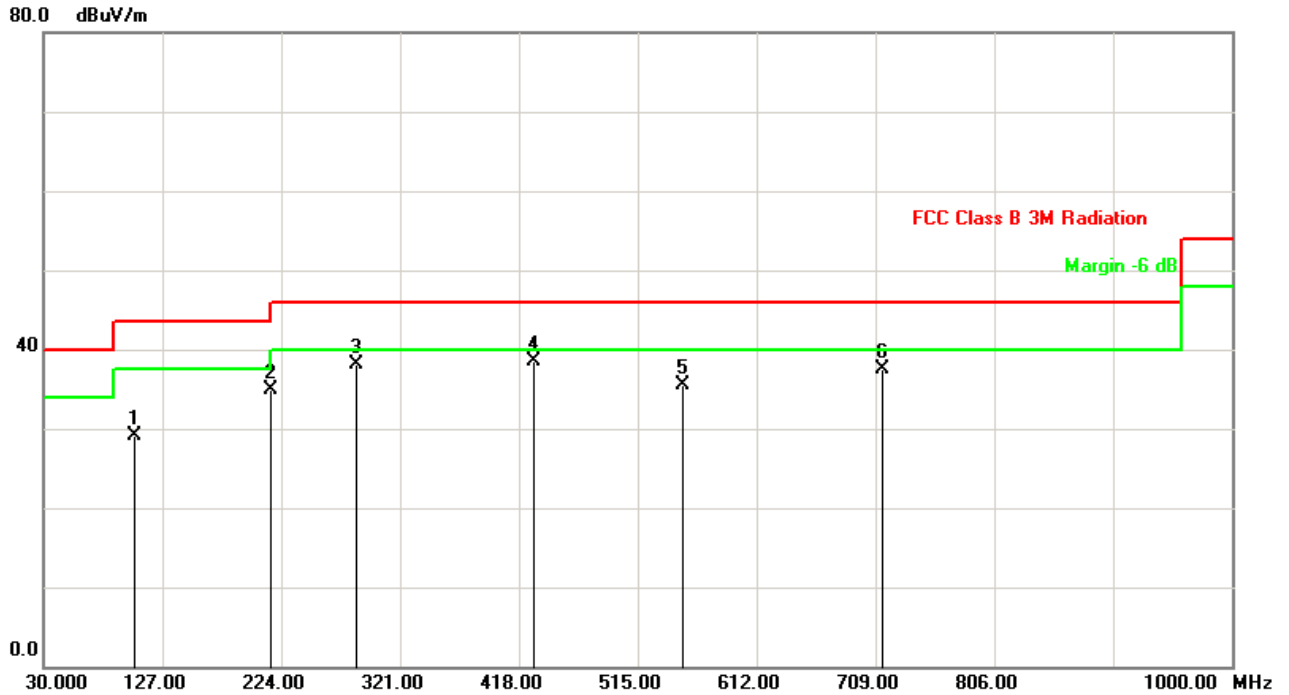

No.	Frequency (MHz)	Factor (dB/m)	Reading (dBuV)	Level (dBuV/m)	Limit (dBuV/m)	Margin (dB)	Det.
1	104.6899	-12.80	41.85	29.05	43.50	-14.45	QP
2	215.2700	-12.25	47.18	34.93	43.50	-8.57	QP
3	286.0799	-8.77	46.88	38.11	46.00	-7.89	QP
4	430.6100	-4.41	42.97	38.56	46.00	-7.44	QP
5	551.8600	-3.60	39.01	35.41	46.00	-10.59	QP
6	714.8200	1.32	36.28	37.60	46.00	-8.40	QP

Note: Measure Level (dBuV/m) = Reading Level (dBuV) + Factor(dB).

Factor (dB)=Cable Loss(dB) + Antenna Factor (dB/m) - Pre_Amplifier Gain(dB)



Limit: FCC_Part15.209_RE(3m)	Margin: 0
Probe: N/A	Polarity: Vertical
EUT: Touch All in one Computer	Power: AC 120V/60Hz
Note: Mode1: Transmit at channel 5220MHz by 802.11a	

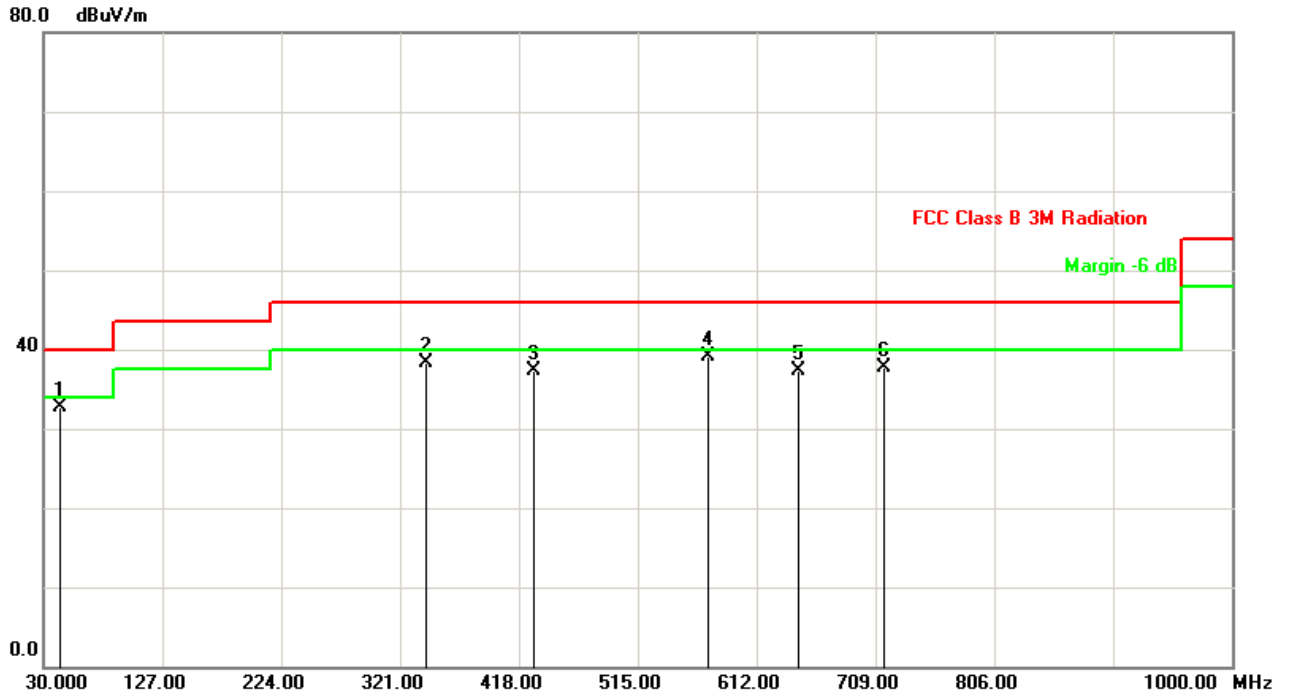

No.	Frequency (MHz)	Factor (dB/m)	Reading (dBuV)	Level (dBuV/m)	Limit (dBuV/m)	Margin (dB)	Det.
1	43.5799	-7.94	40.62	32.68	40.00	-7.32	QP
2	342.3399	-6.61	44.93	38.32	46.00	-7.68	QP
3	430.6100	-4.41	41.78	37.37	46.00	-8.63	QP
4	572.2300	-2.87	42.01	39.14	46.00	-6.86	QP
5	645.9500	-2.17	39.51	37.34	46.00	-8.66	QP
6	716.7599	1.34	36.38	37.72	46.00	-8.28	QP

Note: Measure Level (dBuV/m) = Reading Level (dBuV) + Factor(dB).

Factor (dB)=Cable Loss(dB) + Antenna Factor (dB/m) - Pre_Amplifier Gain(dB)

**Radiated Emission above 1GHz:**

Mode1: Transmit by 802.11a

CH	Antenna	Frequency (MHz)	Reading Level (dBuV/m)	Factor (dB)	Measure Level (dBuV/m)	Limit (dBuV/m)	Margin (dB)	Detector
36	H	10360	36.99	11.63	48.62	54(note3)	-5.38	PK
	H	15540	32.1	19.72	51.82	54(note3)	-2.18	PK
	V	10360	36.55	11.63	48.18	54(note3)	-5.82	PK
	V	15540	28.79	19.72	48.51	54(note3)	-5.49	PK
44	H	10440	37.33	11.85	49.18	54(note3)	-4.82	PK
	H	15660	33.07	19.79	52.86	54(note3)	-1.14	PK
	V	10440	37.73	11.85	49.58	54(note3)	-4.42	PK
	V	15660	30.88	19.79	50.67	54(note3)	-3.33	PK
48	H	10480	37.61	11.75	49.36	54(note3)	-4.64	PK
	H	15720	32.49	19.82	52.31	54(note3)	-1.69	PK
	V	10480	36.3	11.75	48.05	54(note3)	-5.95	PK
	V	15720	30.1	19.82	49.92	54(note3)	-4.08	PK
149	H	11490	32.73	10.13	42.86	54(note3)	-11.14	PK
	H	17235	28.57	17.63	46.2	54(note3)	-7.8	PK
	V	11490	32.2	10.13	42.33	54(note3)	-11.67	PK
	V	17235	28.59	17.63	46.22	54(note3)	-7.78	PK
157	H	11570	32.32	9.92	42.24	54(note3)	-11.76	PK
	H	17355	29.9	15.26	45.16	54(note3)	-8.84	PK
	V	11570	32.47	9.92	42.39	54(note3)	-11.61	PK
	V	17355	28.33	15.26	43.59	54(note3)	-10.41	PK
165	H	11650	32.33	9.52	41.85	54(note3)	-12.15	PK
	H	17475	30.28	17.19	47.47	54(note3)	-6.53	PK
	V	11650	32.47	9.52	41.99	54(note3)	-12.01	PK
	V	17475	28.04	17.19	45.23	54(note3)	-8.77	PK

Note: 1. Measure Level = Reading Level + Factor.

2. The test trace is same as the ambient noise (the test frequency range: 9kHz~30MHz, 18GHz~25GHz), therefore no data appear in the report.

3. This limit applies for using average detector, if the test result on peak is lower than average limit, then average measurement needn't be performed.

Mode1: Transmit by 802.11n(20MHz)



CH	Antenna	Frequency (MHz)	Reading Level (dBuV/m)	Factor (dB)	Measure Level (dBuV/m)	Limit (dBuV/m)	Margin (dB)	Detector
36	H	10360	33.23	11.63	44.86	54(note3)	-9.14	PK
	H	15540	31.77	19.72	51.49	54(note3)	-2.51	PK
	V	10360	34.81	11.63	46.44	54(note3)	-7.56	PK
	V	15540	28.39	19.72	48.11	54(note3)	-5.89	PK
44	H	10440	32.71	11.85	44.56	54(note3)	-9.44	PK
	H	15660	30.96	19.79	50.75	54(note3)	-3.25	PK
	V	10440	35.17	11.85	47.02	54(note3)	-6.98	PK
	V	15660	28.13	19.79	47.92	54(note3)	-6.08	PK
48	H	10480	32.81	11.75	44.56	54(note3)	-9.44	PK
	H	15720	30.61	19.82	50.43	54(note3)	-3.57	PK
	V	10480	31.32	11.75	43.07	54(note3)	-10.93	PK
	V	15720	28.95	19.82	48.77	54(note3)	-5.23	PK
149	H	11490	30.21	10.13	40.34	54(note3)	-13.66	PK
	H	17235	27.31	17.63	44.94	54(note3)	-9.06	PK
	V	11490	28.82	10.13	38.95	54(note3)	-15.05	PK
	V	17235	27.09	17.63	44.72	54(note3)	-9.28	PK
157	H	11570	30.1	9.92	40.02	54(note3)	-13.98	PK
	H	17355	28.2	15.26	43.46	54(note3)	-10.54	PK
	V	11570	29.33	9.92	39.25	54(note3)	-14.75	PK
	V	17355	28.18	15.26	43.44	54(note3)	-10.56	PK
165	H	11650	30.28	9.52	39.80	54(note3)	-14.20	PK
	H	17475	27.52	17.19	44.71	54(note3)	-9.29	PK
	V	11650	27.84	9.52	37.36	54(note3)	-16.64	PK
	V	17475	27.88	17.19	45.07	54(note3)	-8.93	PK

Note: 1. Measure Level = Reading Level + Factor.

2. The test trace is same as the ambient noise (the test frequency range: 9kHz~30MHz, 18GHz~25GHz), therefore no data appear in the report.

3. This limit applies for using average detector, if the test result on peak is lower than average limit, then average measurement needn't be performed.



Mode3: Transmit by 802.11n(40MHz)

CH	Antenna	Frequency (MHz)	Reading Level (dBuV/m)	Factor (dB)	Measure Level (dBuV/m)	Limit (dBuV/m)	Margin (dB)	Detector
38	H	10380	27.69	11.63	39.32	54(note3)	-14.68	PK
	H	15570	25.1	19.72	44.82	54(note3)	-9.18	PK
	V	10380	26.44	11.63	38.07	54(note3)	-15.93	PK
	V	15570	26.25	19.72	45.97	54(note3)	-8.03	PK
46	H	10460	29.3	11.85	41.15	54(note3)	-12.85	PK
	H	15690	24	19.79	43.79	54(note3)	-10.21	PK
	V	10460	28.4	11.85	40.25	54(note3)	-13.75	PK
	V	15690	26.23	19.79	46.02	54(note3)	-7.98	PK
151	H	11510	31.42	11.75	43.17	54(note3)	-10.83	PK
	H	17265	28.63	19.82	48.45	54(note3)	-5.55	PK
	V	11510	27.89	11.75	39.64	54(note3)	-14.36	PK
	V	17265	28.03	19.82	47.85	54(note3)	-6.15	PK
159	H	11590	29.94	10.13	40.07	54(note3)	-13.93	PK
	H	17385	29.21	17.63	46.84	54(note3)	-7.16	PK
	V	11590	27.73	10.13	37.86	54(note3)	-16.14	PK
	V	17385	27.38	17.63	45.01	54(note3)	-8.99	PK

Note: 1. Measure Level = Reading Level + Factor.

2. The test trace is same as the ambient noise (the test frequency range: 9kHz~30MHz, 18GHz~25GHz), therefore no data appear in the report.

3. This limit applies for using average detector, if the test result on peak is lower than average limit, then average measurement needn't be performed.



Mode4: Transmit by 802.11ac(80)

CH	Antenna	Frequency (MHz)	Reading Level (dBuV/m)	Factor (dB)	Measure Level (dBuV/m)	Limit (dBuV/m)	Margin (dB)	Detector
42	H	10420	28.24	11.63	39.87	54(note3)	-14.13	PK
	H	15630	26.5	19.72	46.22	54(note3)	-7.78	PK
	V	10420	28.65	11.63	40.28	54(note3)	-13.72	PK
	V	15630	26.32	19.72	46.04	54(note3)	-7.96	PK
155	H	11550	28.49	11.85	40.34	54(note3)	-13.66	PK
	H	17325	28.24	19.79	48.03	54(note3)	-5.97	PK
	V	11550	27.76	11.85	39.61	54(note3)	-14.39	PK
	V	17325	26.63	19.79	46.42	54(note3)	-7.58	PK

Note: 1. Measure Level = Reading Level + Factor.

2. The test trace is same as the ambient noise (the test frequency range: 9kHz~30MHz, 18GHz~25GHz), therefore no data appear in the report.

3. This limit applies for using average detector, if the test result on peak is lower than average limit, then average measurement needn't be performed.



The worst case of Radiated Emission 1~18GHz:

Site:AC102	Time: 2017/09/13
Limit: FCC_Part15.209_RE(3m)	Margin: 0
Probe: N/A	Polarity: Horizontal
EUT:Touch All in one Computer	Power: AC 120V/60Hz
Note: Mode: Transmit 802.11a at 5220MHz	

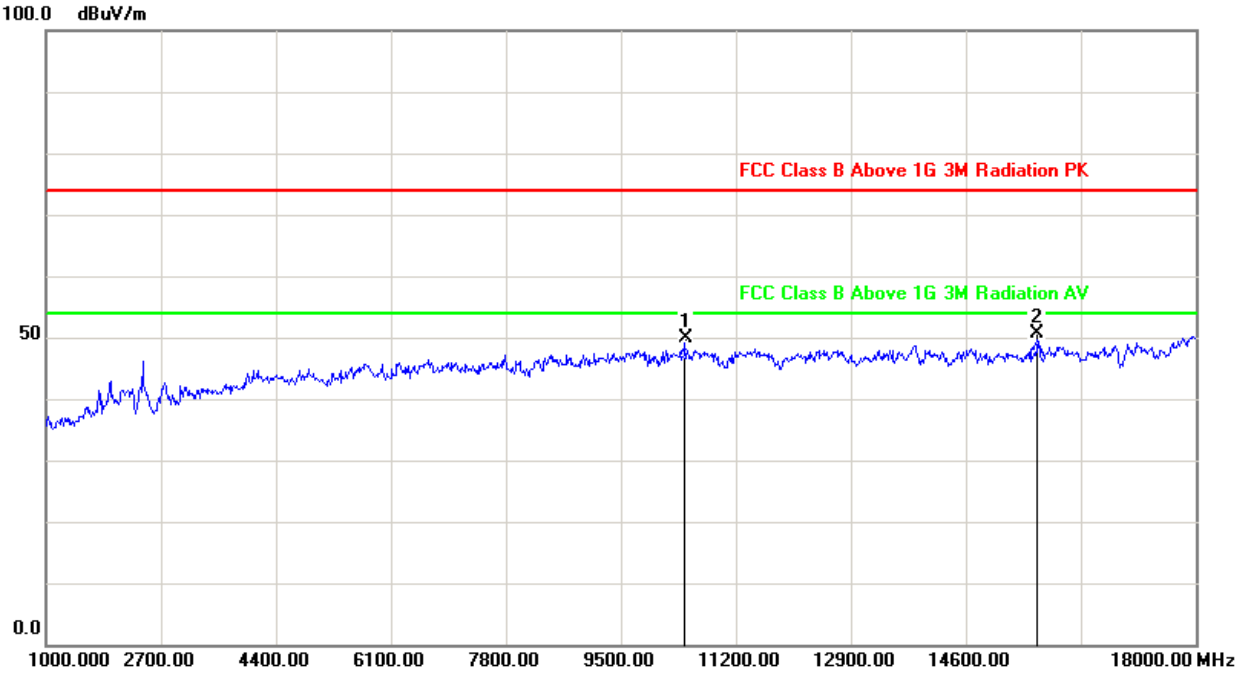

No.	Frequency (MHz)	Factor (dB/m)	Reading (dBuV)	Level (dBuV/m)	Limit (dBuV/m)	Margin (dB)	Det.
1	10440.000	11.85	37.33	49.18	54(note3)	-4.82	peak
2	15660.000	19.79	33.07	52.86	54(note3)	-1.14	peak

Note:

1. All Readings below 1GHz are Quasi-Peak, above are performed with peak and/or AVG measurements as necessary.
2. Measurement Level = Reading Level + Correct Factor
3. The test trace is same as the ambient noise (the test frequency range: 9kHz~30MHz, 18GHz~40GHz), therefore no data appear in the report.



Site:AC102	Time: 2017/09/13
Limit: FCC_Part15.209_RE(3m)	Margin: 0
Probe: N/A	Polarity: Vertical
EUT:Touch All in one Computer	Power: AC 120V/60Hz
Note: Mode: Transmit 802.11a at 5220MHz	

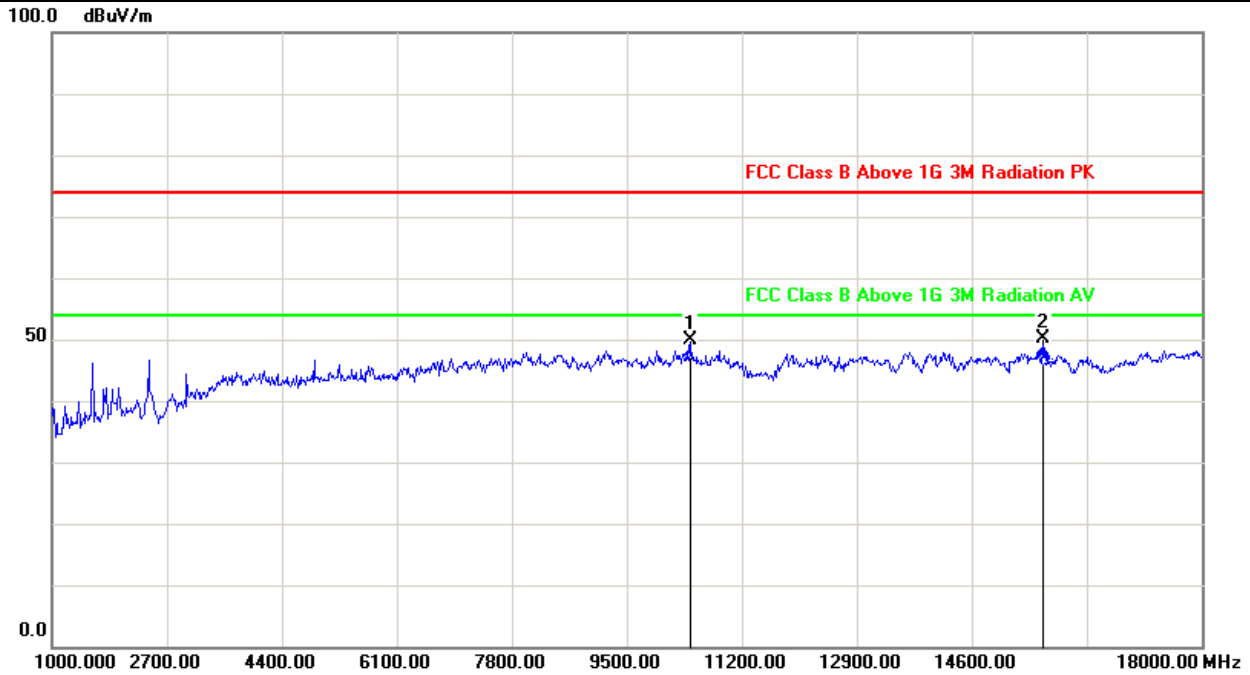

No.	Frequency (MHz)	Factor (dB/m)	Reading (dBuV)	Level (dBuV/m)	Limit (dBuV/m)	Margin (dB)	Det.
1	10440.000	11.85	37.73	49.58	54(note3)	-4.42	peak
2	15660.000	19.79	30.88	50.67	54(note3)	-3.33	peak

Note:

1. All Readings below 1GHz are Quasi-Peak, above are performed with peak and/or AVG measurements as necessary.
2. Measurement Level = Reading Level + Correct Factor
3. The test trace is same as the ambient noise (the test frequency range: 9kHz~30MHz, 18GHz~40GHz), therefore no data appear in the report.



5. 26dB Occupied Bandwidth

5.1 Test Limit

N/A

5.2 Test Standard

KDB 789033 D02v01r04– Section C.1



5.3 Test Procedures

The EUT was tested according to KDB 789033 for compliance to FCC 47CFR 15.407 requirements.

Emission Bandwidth

- Use a RBW = approximately 1% of the emission bandwidth.
- Set the VBW > RBW
- Detector = Peak.
- Trace mode = max hold.
- Measure the maximum width of the emission that is 26 dB down from the peak of the emission. Compare this with the RBW setting of the analyzer. Readjust RBW and repeat measurement as needed until the RBW/EBW ratio is approximately 1%.

99% Occupied Bandwidth

- Set center frequency to the nominal EUT channel center frequency.
- Set span = 1.5 times to 5.0 times the OBW.
- Set RBW = 1 % to 5 % of the OBW.
- Set VBW $\geq 3 \cdot$ RBW.
- Video averaging is not permitted. Where practical, a sample detection and single sweep mode shall be used. Otherwise, peak detection and max hold mode (until the trace stabilizes) shall be used.
- Use the 99 % power bandwidth function of the instrument (if available).
- If the instrument does not have a 99 % power bandwidth function, the trace data points are recovered and directly summed in power units. The recovered amplitude data points, beginning at the lowest frequency, are placed in a running sum until 0.5 % of the total is reached; that frequency is recorded as the lower frequency. The process is repeated until 99.5 % of the total is reached; that frequency is recorded as the upper frequency. The 99% occupied bandwidth is the difference between these two frequencies.



5.4 Test Setup

Spectrum Analyzer

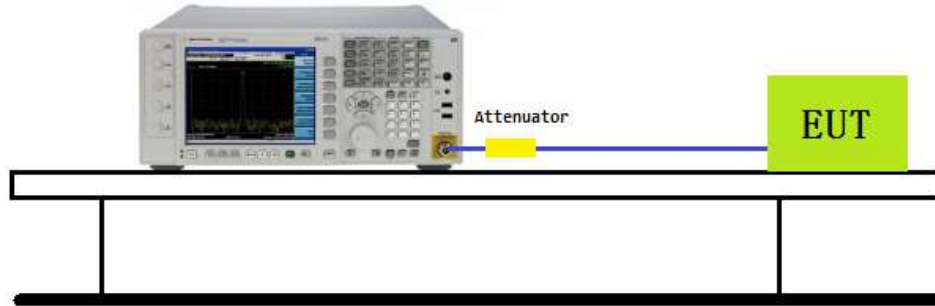



5.5 Test Result and Data

Test Item	Occupied Bandwidth
Test Mode	Transmit by 802.11a
Test Date	2017-09-07

Channel No.	Frequency (MHz)	26dB Bandwidth (MHz)	99% Occupied Bandwidth (MHz)	Result
36	5180	22.18	16.964	Pass
44	5220	22.26	16.900	Pass
48	5240	22.27	16.909	Pass
149	5745	22.11	16.891	Pass
157	5785	22.17	16.930	Pass
165	5825	22.16	16.927	Pass

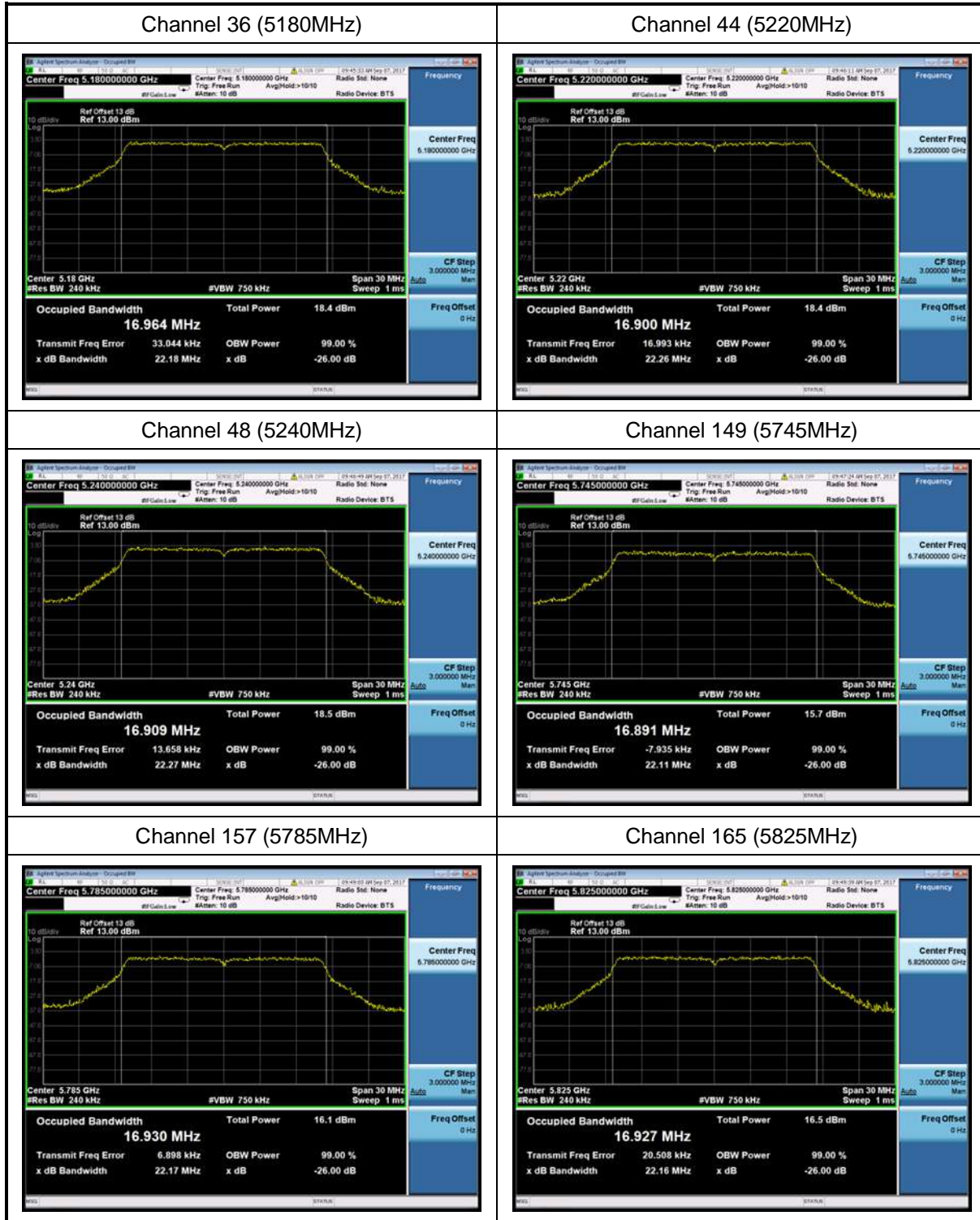



Test Item	Occupied Bandwidth
Test Mode	Transmit by 802.11n(20MHz)
Test Date	2017-09-07

Channel No.	Frequency (MHz)	26dB Bandwidth (MHz)	99% Occupied Bandwidth (MHz)	Result
36	5180	22.55	17.994	Pass
44	5220	22.63	17.993	Pass
48	5240	22.57	17.909	Pass
149	5745	22.07	17.944	Pass
157	5785	22.72	17.987	Pass
165	5825	22.54	17.941	Pass

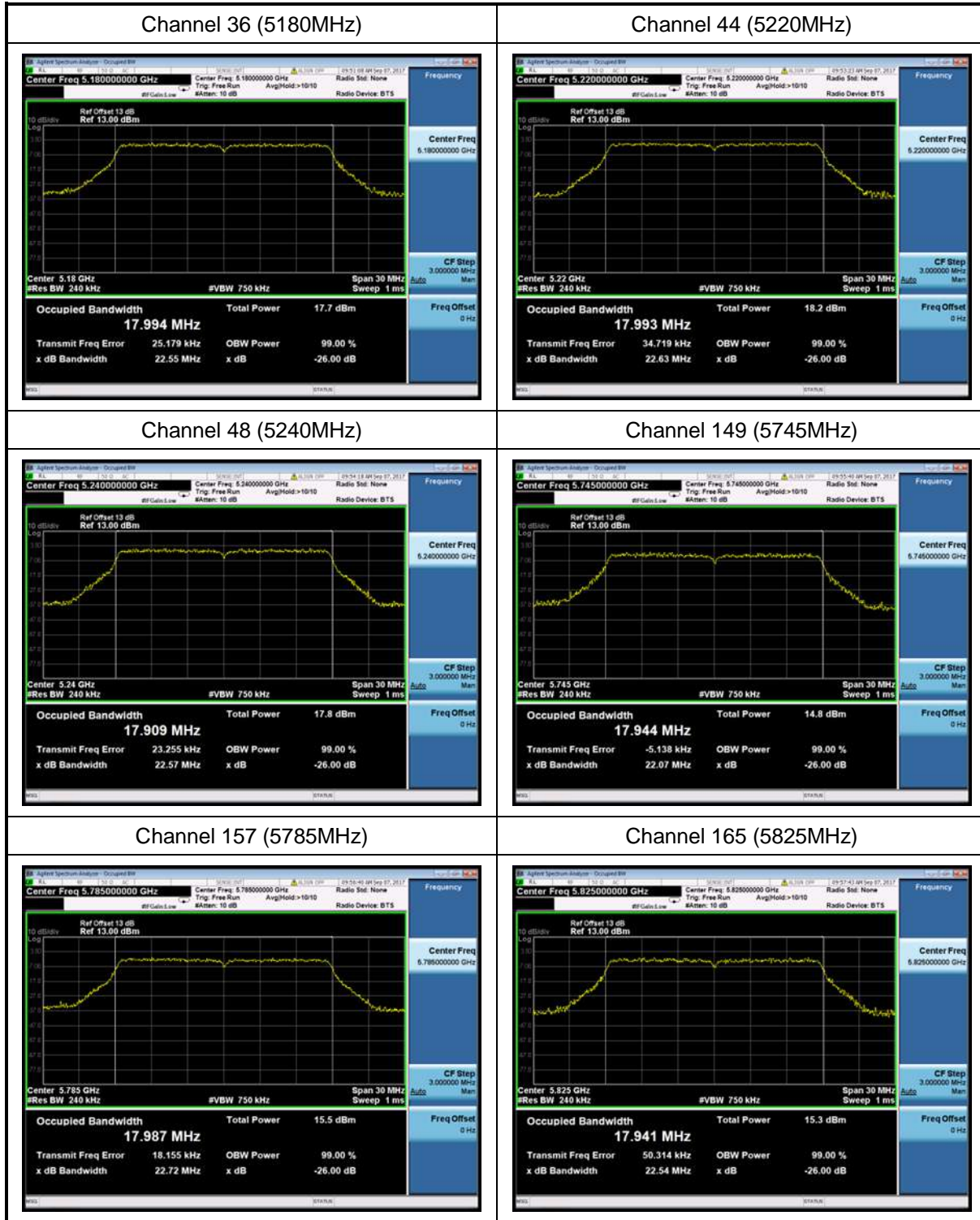



Test Item	Occupied Bandwidth
Test Mode	Transmit by 802.11n(40MHz)
Test Date	2017-09-07

Channel No.	Frequency (MHz)	26dB Bandwidth (MHz)	99% Occupied Bandwidth (MHz)	Result
38	5190	43.56	36.292	Pass
46	5230	44.14	36.323	Pass
151	5755	42.78	36.212	Pass
159	5795	43.67	36.238	Pass

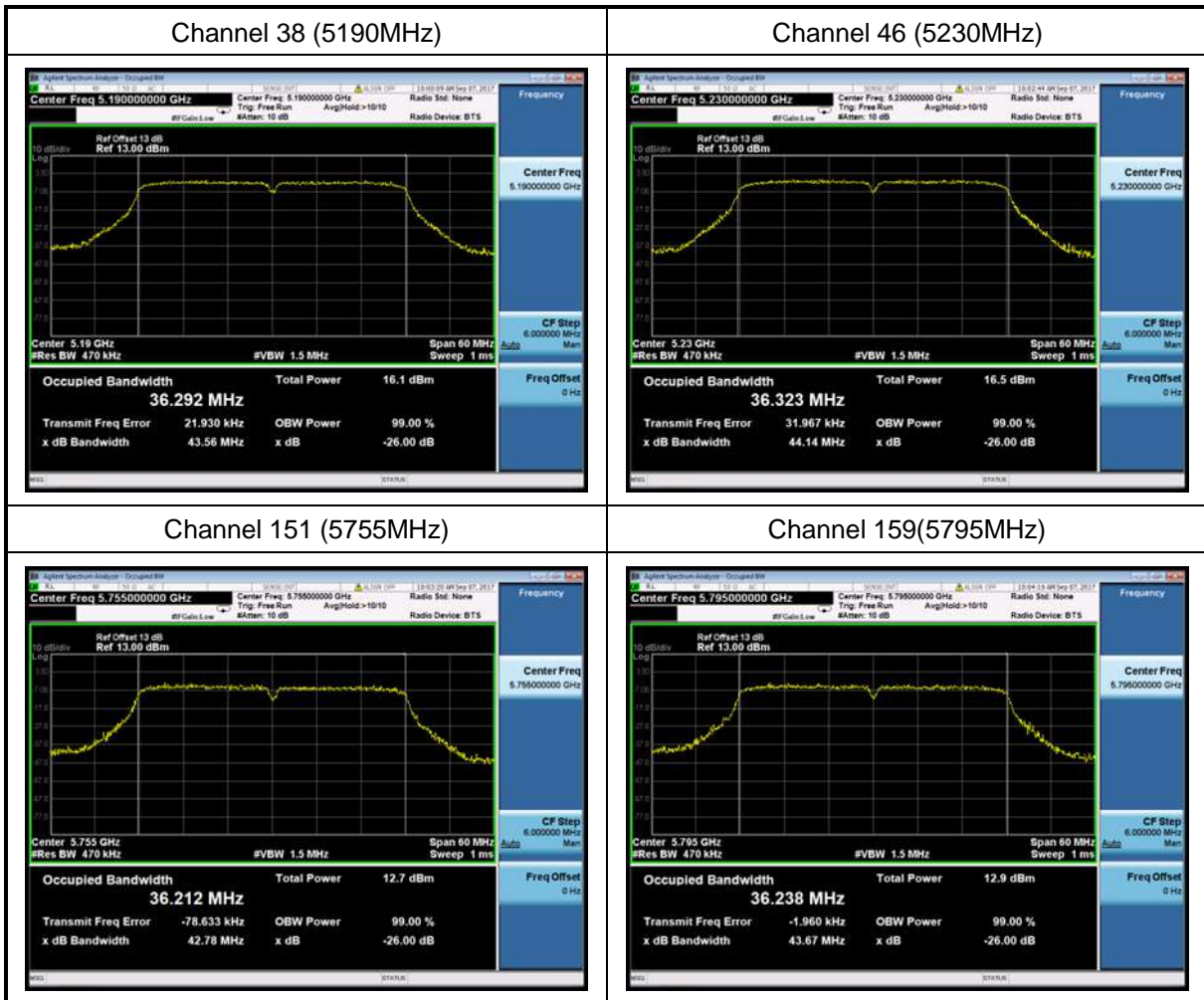



Test Item	Occupied Bandwidth
Test Mode	Transmit by 802.11ac(80MHz)
Test Date	2017-09-07

Channel No.	Frequency (MHz)	26dB Bandwidth (MHz)	99% Occupied Bandwidth (MHz)	Result
42	5210	84.49	74.823	Pass
155	5775	84.08	74.868	Pass

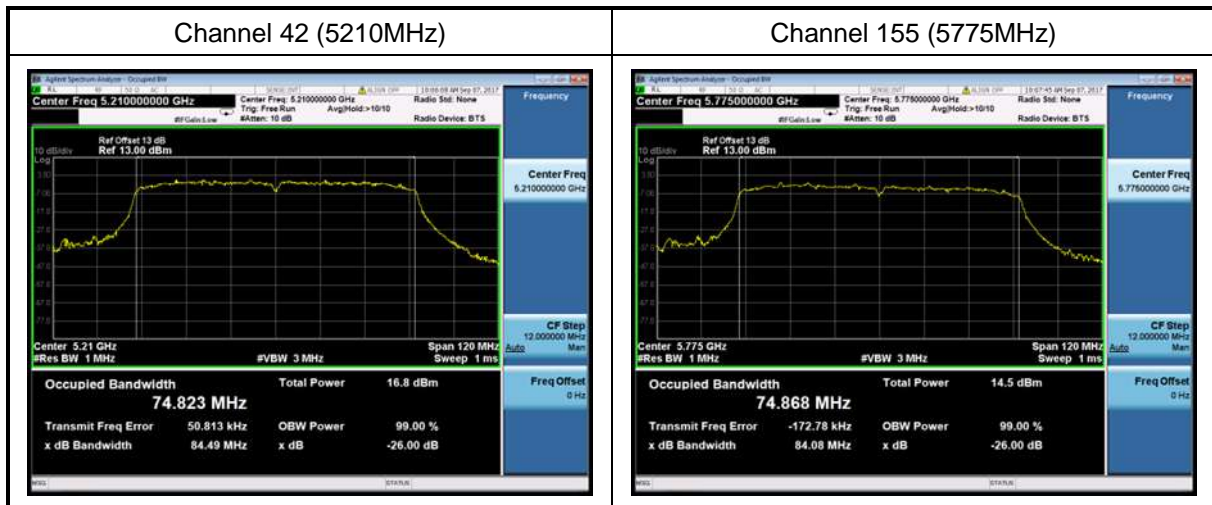



6. 6dB Bandwidth Measurement

6.1 Test Limit

Section 15.407(e) specifies the minimum 6 dB emission bandwidth of at least 500 kHz for the band 5.725-5.85 GHz.

6.2 Test Standard

KDB 789033 D02v01r04 – Section C.2

6.3 Test Procedures

1. Set center frequency to the nominal EUT channel center frequency.
2. RBW = 100 kHz.
3. VBW $\geq 3 \times$ RBW.
4. Detector = Peak.
5. Trace mode = max hold.
6. Sweep = auto couple.
7. Allow the trace to stabilize.
8. Measure the maximum width of the emission that is constrained by the frequencies associated with the two outermost amplitude points (upper and lower frequencies) that are attenuated by 6 dB relative to the maximum level measured in the fundamental emission.

Note: The automatic bandwidth measurement capability of a spectrum analyzer or EMI receiver may be employed if it implements the functionality described above.

6.4 Test Setup

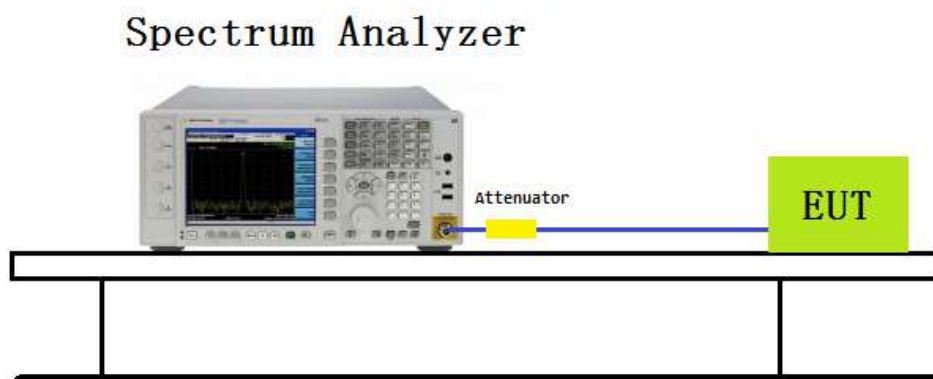



6.5 Test Result and Data

Test Item	6dB Bandwidth Measurement
Test Mode	Transmit by 802.11a
Test Date	2017-09-07

Channel No.	Frequency (MHz)	Measurement Level (MHz)	Result
149	5745	16.38	Pass
157	5785	16.39	Pass
165	5825	16.41	Pass

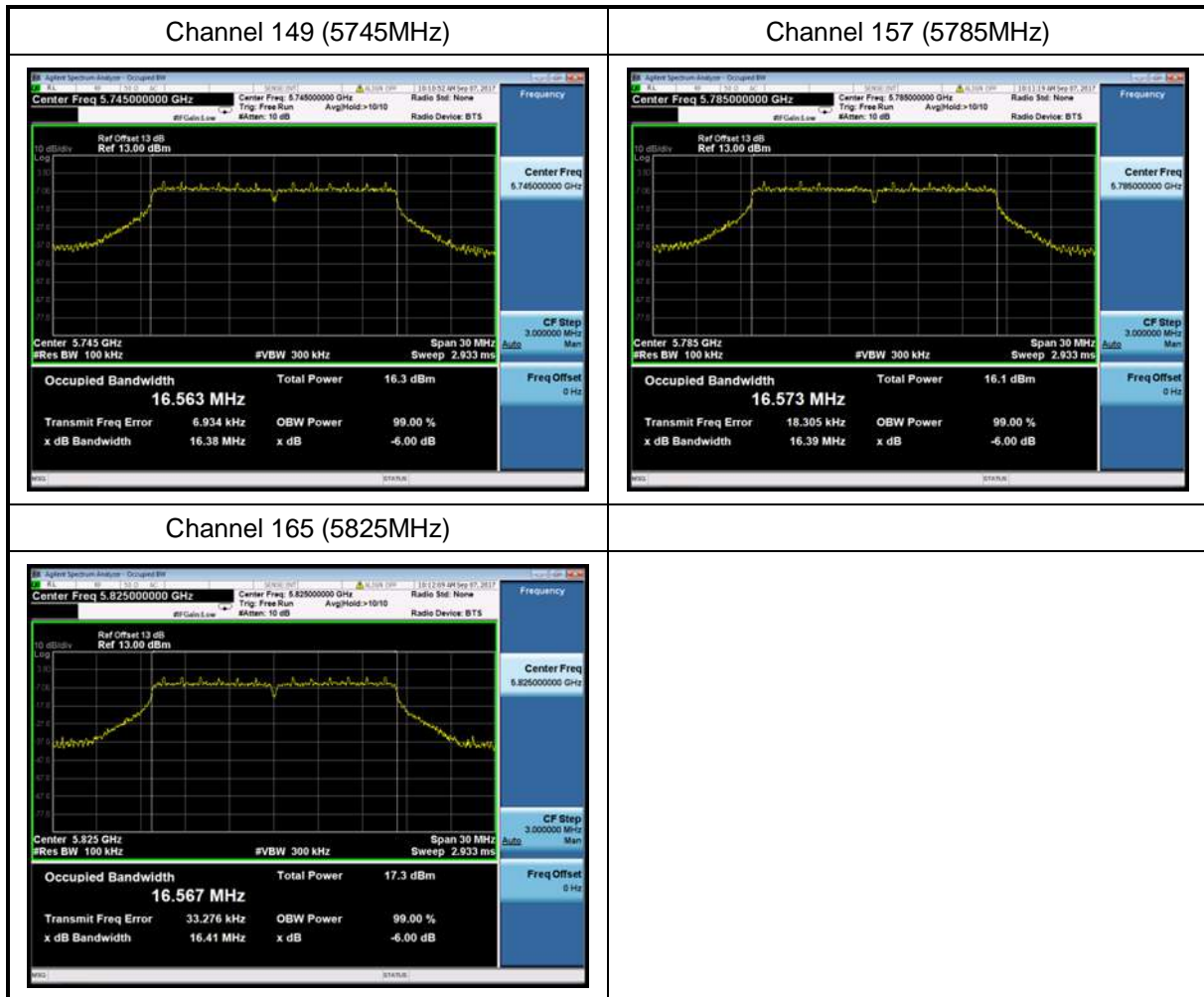



Test Item	6dB Bandwidth Measurement
Test Mode	Transmit by 802.11n(20MHz)
Test Date	2017-09-07

Channel No.	Frequency (MHz)	Measurement Level (MHz)	Result
149	5745	17.61	Pass
157	5785	17.61	Pass
165	5825	17.63	Pass





Test Item	6dB Bandwidth Measurement
Test Mode	Transmit by 802.11n(40MHz)
Test Date	2017-09-07

Channel No.	Frequency (MHz)	Measurement Level (MHz)	Result
151	5755	35.34	Pass
159	5795	35.19	Pass

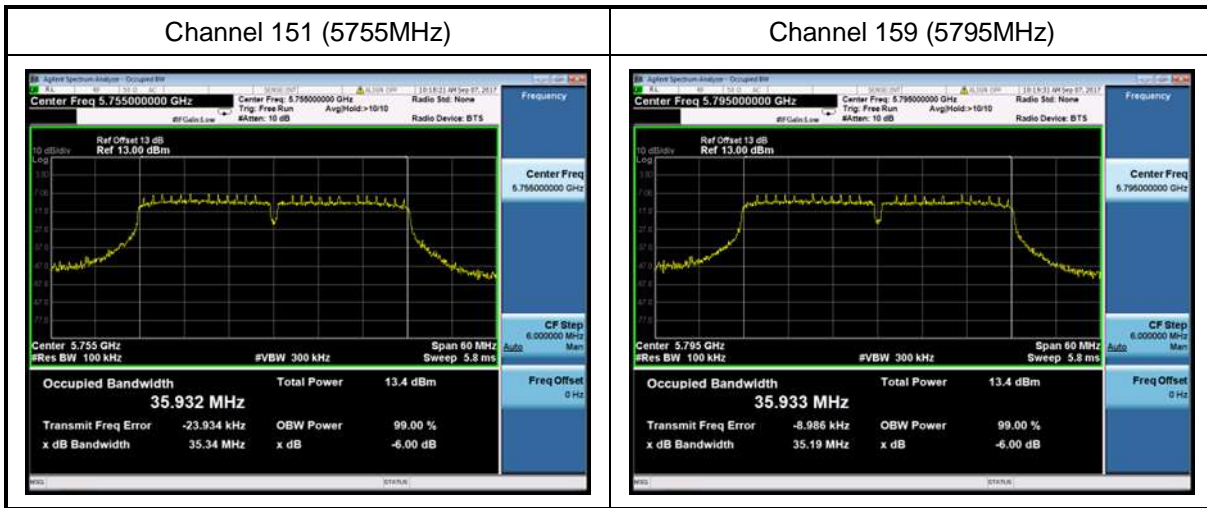



Test Item	6dB Bandwidth Measurement
Test Mode	Transmit by 802.11ac(80MHz)
Test Date	2017-09-07

Channel No.	Frequency (MHz)	Measurement Level (MHz)	Result
155	5775	74	Pass

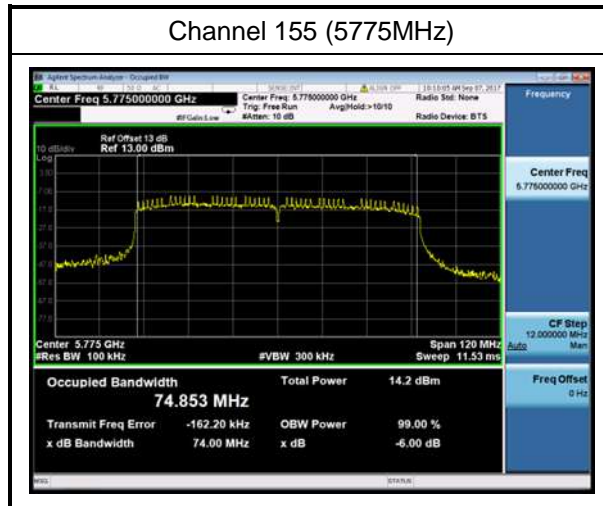



7. Power Output

7.1 Test Limit

According to §15.407(a) Power Limits:

- For an indoor access point operating in the band 5.15-5.25 GHz, the maximum conducted output power over the frequency band of operation shall not exceed 1 W (30dBm).. If transmitting antenna of directional gain greater than 6 dBi are used, the maximum conducted output power shall be reduced by the amount in dB that directional gain of the antenna exceeds 6 dBi.
- For the band 5.25-5.35 GHz and 5.47-5.725 GHz bands, the maximum conducted output power over the frequency bands of operation shall not exceed the lesser of 250 mW or 11 dBm + 10log B, where B is the 26 dB emission bandwidth in megahertz. If transmitting antenna of directional gain greater than 6 dBi are used, the maximum conducted output power shall be reduced by the amount in dB that directional gain of the antenna exceeds 6 dBi.
- For the band 5.725-5.825 GHz, the maximum conducted output power over the frequency band of operation shall not exceed the lesser of 1 W or 17 dBm + 10log B, where B is the 26 dB emission bandwidth in MHz. If transmitting antenna of directional gain greater than 6 dBi are used, the maximum conducted output power shall be reduced by the amount in dB that directional gain of the antenna exceeds 6 dBi. However, fixed point-to-point U-NII devices operating in this band may employ transmitting antenna with directional gain up to 23 dBi without any corresponding reduction in the transmitter peak output power. For fixed, point-to-point U-NII transmitters that employ a directional antenna gain greater than 23 dBi, a 1 dB reduction in peak transmitter power for each 1 dB of antenna gain in excess of 23 dBi would be required.

5.15-5.25 GHz: Limit (dBm) = 30dBm

5.725-5.85 GHz Limit (dBm) = 30dBm

7.2 Test Standard

KDB 789033 D02v01r04 - Section E) 3) b) Method PM-G



7.3 Test Procedures

Measurements may be performed using a wideband gated RF power meter provided that the gate parameters are adjusted such that the power is measured only when the EUT is transmitting at its maximum power control level. Since the measurement is made only during the ON time of the transmitter, no duty cycle correction factor is required.

7.4 Test Setup

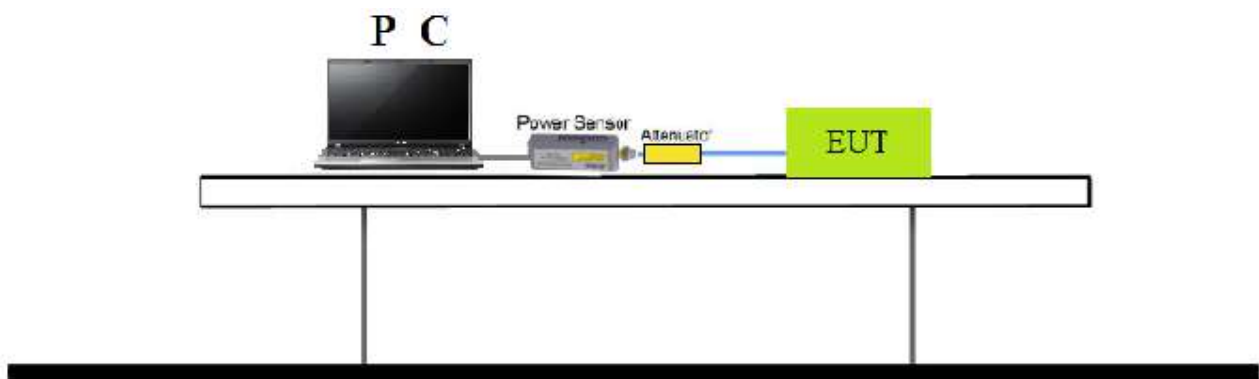



7.5 Test Result and Data

Power output test was verified over all data rates of each mode shown as below, and then choose the maximum power output (yellow marker) for final test of each channel.

MCS Index for 802.11n	Spatial Streams	Data Rate (Mbps)				
		802.11a	20MHz Bandwidth		40MHz Bandwidth	
			800ns GI	400ns GI	800ns GI	400ns GI
0	1	6	6.5	7.2	13.5	15.0
1	1	9	13.0	14.4	27.0	30.0
2	1	12	19.5	21.7	40.5	45.0
3	1	18	26.0	28.9	54.0	60.0
4	1	24	39.0	43.3	81.0	90.0
5	1	36	52.0	57.8	108.0	120.0
6	1	48	58.5	65.0	121.5	135.0
7	1	54	65.0	72.2	135.0	150.0
8	2	---	13.0	14.4	27.0	30.0
9	2	---	26.0	28.9	54.0	60.0
10	2	---	39.0	43.3	81.0	90.0
11	2	---	52.0	57.8	108.0	120.0
12	2	---	78.0	86.7	162.0	180.0
13	2	---	104.0	115.6	216.0	240.0
14	2	---	117.0	130.0	243.0	270.0
15	2	---	130.0	144.0	270.0	300.0



Spatial Streams	MCS Index	Modulation type	Coding rate	Data Rate(Mb/s)							
				20MHz		40MHz		80MHz		160MHz	
				Guard Interval		Guard Interval		Guard Interval		Guard Interval	
				800ns	400ns	800ns	400ns	800ns	400ns	800ns	400ns
1	0	BPSK	1/2	6.5	7.2	13.5	15	29.3	32.5	58.5	65
	1	QPSK	1/2	13	14.4	27	30	58.5	65	117	130
	2	QPSK	3/4	19.5	21.7	40.5	45	87.8	97.5	175.5	195
	3	16-QAM	1/2	26	28.9	54	60	117	130	234	260
	4	16-QAM	3/4	39	43.3	81	90	175.5	195	351	390
	5	64-QAM	2/3	52	57.8	108	120	234	260	468	520
	6	64-QAM	3/4	58.5	65	121.5	135	263.3	292.5	526.5	585
	7	64-QAM	5/6	65	72.2	135	150	292.5	325	585	650
	8	256-QAM	3/4	78	86.7	162	180	351	390	702	780
	9	256-QAM	5/6	N/A	N/A	180	200	390	433.3	780	866.7
2	0	BPSK	1/2	13	14.4	27	30	58.6	65	117	130
	1	QPSK	1/2	26	28.8	54	60	117	130	234	260
	2	QPSK	3/4	39	43.4	81	90	175.6	195	351	390
	3	16-QAM	1/2	52	57.8	108	120	234	260	468	520
	4	16-QAM	3/4	78	86.6	162	180	351	390	702	780
	5	64-QAM	2/3	104	115.6	216	240	468	520	936	1040
	6	64-QAM	3/4	117	130	243	270	526.6	585	1053	1170
	7	64-QAM	5/6	130	144.4	270	300	585	650	1170	1300
	8	256-QAM	3/4	156	173.4	324	360	702	780	1404	1560
	9	256-QAM	5/6	N/A	N/A	360	400	780	866.6	1560	1733.4



Test Mode	Data Rate (Mbps)	Channel No.	Freq. (MHz)	Average Power (dBm)	Limit (dBm)	Result
802.11a	13	36	5180	11.87	30	Pass
		44	5220	11.96	30	Pass
		48	5240	11.98	30	Pass
		149	5745	10.43	30	Pass
		157	5785	10.73	30	Pass
		165	5825	10.98	30	Pass
802.11n(20MHz)	13	36	5180	11.78	30	Pass
		44	5220	11.86	30	Pass
		48	5240	11.89	30	Pass
		149	5745	10.29	30	Pass
		157	5785	10.43	30	Pass
		165	5825	10.86	30	Pass
802.11n(40MHz)	27	38	5190	8.94	30	Pass
		46	5230	8.98	30	Pass
		151	5755	9.57	30	Pass
		159	5795	9.99	30	Pass
802.11ac(80MHz)	58.6	42	5210	8.04	30	Pass
		155	5775	7.28	30	Pass



8. Power Spectral Density

8.1 Test Limit

According to FCC 47 CFR Section 15.407 a) PSD Limits:

For an indoor access point operating in the band 5.15-5.25 GHz, the maximum power spectral density shall not exceed 17 dBm in any 1 megahertz band.

For the 5.25-5.35 GHz and 5.47-5.725 GHz bands, the maximum power spectral density shall not exceed 11 dBm in any 1 megahertz band.

For the band 5.725-5.85 GHz, the maximum power spectral density shall not exceed 30 dBm in any 500-kHz band.

If transmitting antennas of directional gain greater than 6dBi are used, the peak power spectral density shall be reduced by the amount in dB that the directional gain of the antenna exceeds 6dBi.

5.15-5.25 GHz: Limit (dBm) = 17dBm/MHz

5.725-5.85 GHz Limit (dBm/500kHz) = 30dBm/500kHz

8.2 Test Standard

KDB 789033 D02v01r04 - Section F



8.3 Test Procedures

1. Analyzer was set to the center frequency of the UNII channel under investigation
2. Span was set to encompass the entire 26dB EBW of the signal.
3. RBW = 1MHz, if measurement bandwidth of Maximum PSD is specified in 500 kHz, RBW = 100 kHz
4. VBW = 3MHz
5. Number of sweep points $\geq 2 \times (\text{span} / \text{RBW})$
6. Detector = power averaging (RMS)
7. Sweep time = auto
8. Trigger = free run
9. Use the peak search function on the instrument to find the peak of the spectrum and record its value.
10. Add $10 \cdot \log(1/x)$, where x is the duty cycle, to the measured power in order to compute the average power during the actual transmission times (because the measurement represents an average over both the on and off times of the transmission). For example, add $10 \cdot \log(1/0.25) = 6$ dB if the duty cycle is 25 percent.
11. When the measurement bandwidth of Maximum PSD is specified in 500 kHz, add a constant factor $10 \cdot \log(500\text{kHz}/100\text{kHz}) = 7$ dB to the measured result.

8.4 Test Setup

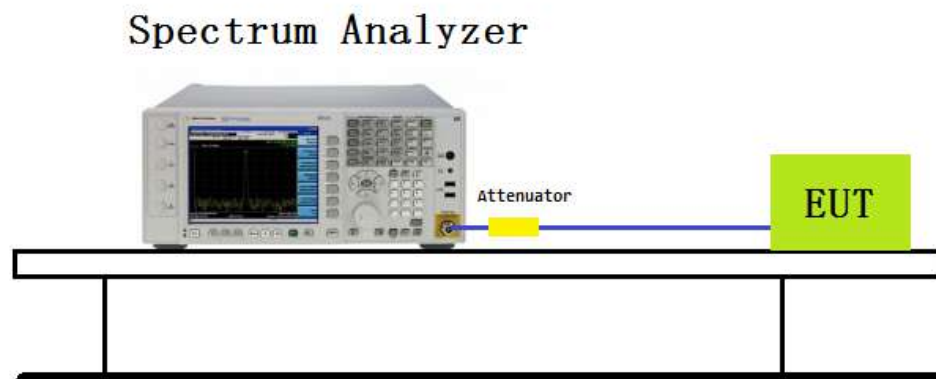

**8.5 Test Result and Data**

Test Mode	Data Rate (Mbps)	Channel No.	Freq. (MHz)	PSD (dBm/MHz)	Limit (dBm/MHz)	Result
802.11a	6	36	5180	-0.415	17	Pass
		44	5220	-0.411	17	Pass
		48	5240	-0.398	17	Pass
802.11n (20MHz)	13	36	5180	-1.723	17	Pass
		44	5220	-1.787	17	Pass
		48	5240	-1.103	17	Pass
802.11n (40MHz)	27	38	5190	-6.797	17	Pass
		46	5230	-6.924	17	Pass
802.11ac (80MHz)	58.6	42	5210	-11.935	17	Pass

Test Mode	Data Rate (Mbps)	CH.	Freq. (MHz)	Measured PSD(dBm/500K Hz)	Constant Factor	Total PSD	Limit (dBm/500kHz)	Result
802.11a	6	149	5745	-11.520	7	-4.520	30	Pass
		157	5785	-12.288	7	-5.288	30	Pass
		165	5825	-10.862	7	-3.862	30	Pass
802.11n (20MHz)	13	149	5745	-12.954	7	-5.954	30	Pass
		157	5785	-12.210	7	-5.210	30	Pass
		165	5825	-12.218	7	-5.218	30	Pass
802.11n (40MHz)	27	151	5755	-17.689	7	-10.689	30	Pass
		159	5795	-18.898	7	-11.898	30	Pass
802.11ac (80MHz)	58.6	155	5775	-20.817	7	-13.817	30	Pass

Note: Total PSD = Measured PSD + Constant Factor.



802.11a Power Spectral Density

Channel 36 (5180MHz)

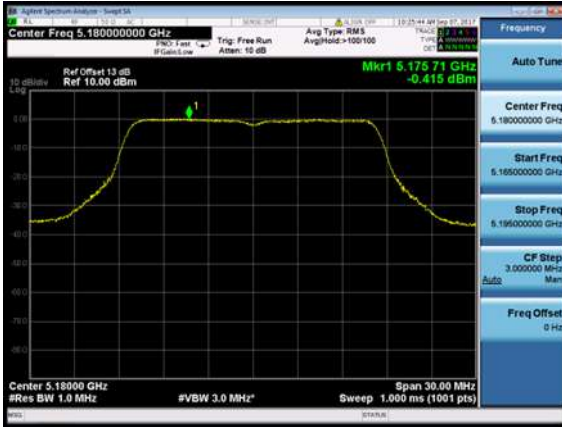

Channel 44 (5220MHz)

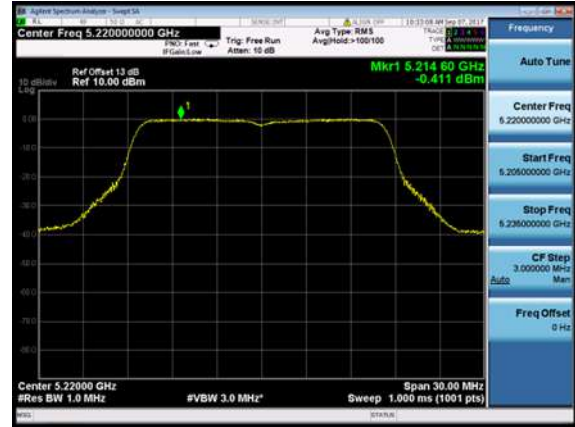

Channel 48 (5240MHz)

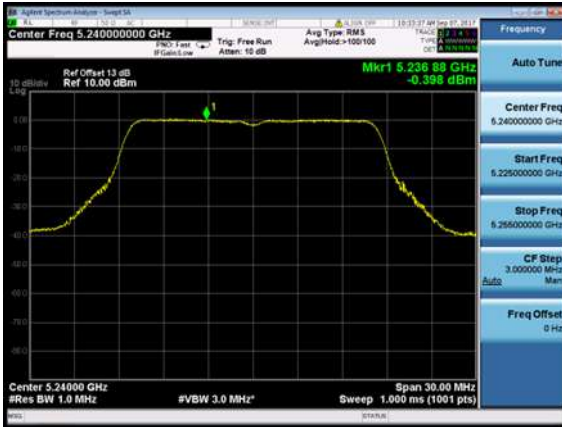

Channel 149 (5745MHz)

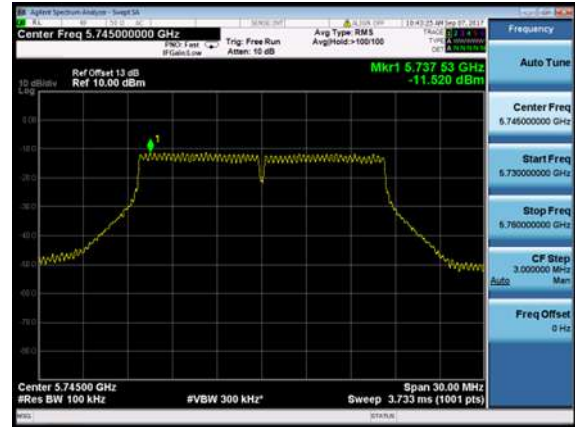

Channel 157 (5785MHz)

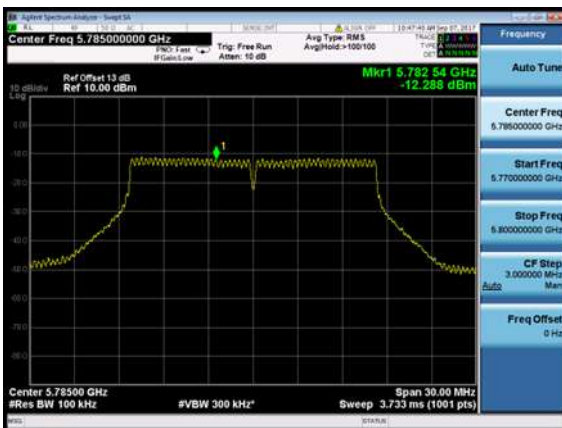

Channel 165 (5825MHz)

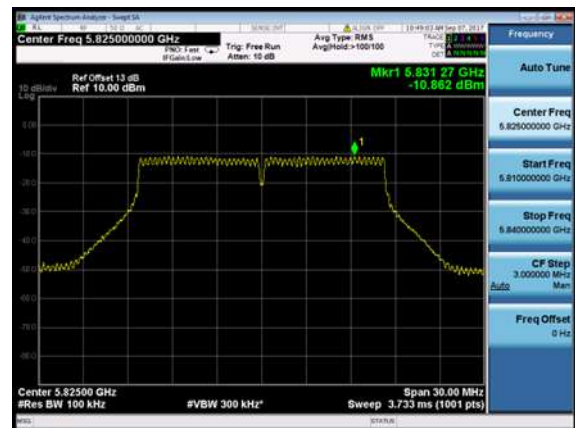



802.11 n(20MHz) Power Spectral Density

Channel 36 (5180MHz)

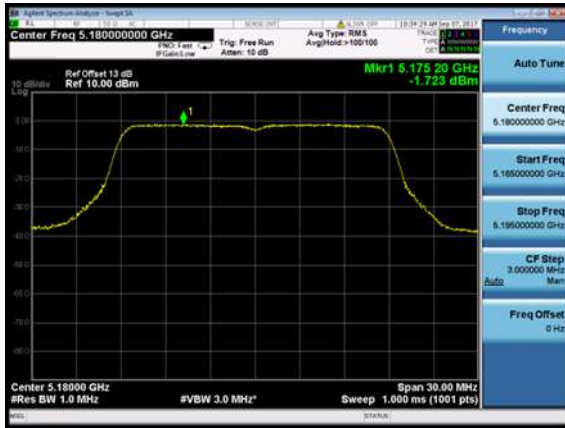

Channel 44 (5220MHz)

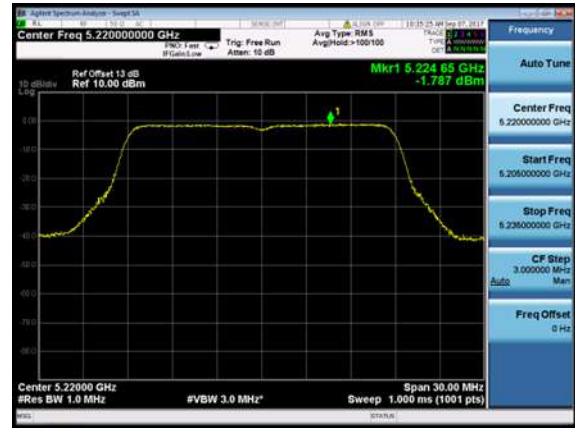

Channel 48 (5240MHz)

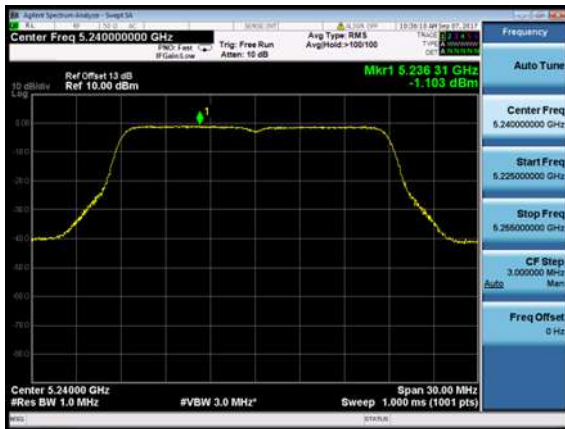

Channel 149 (5745MHz)

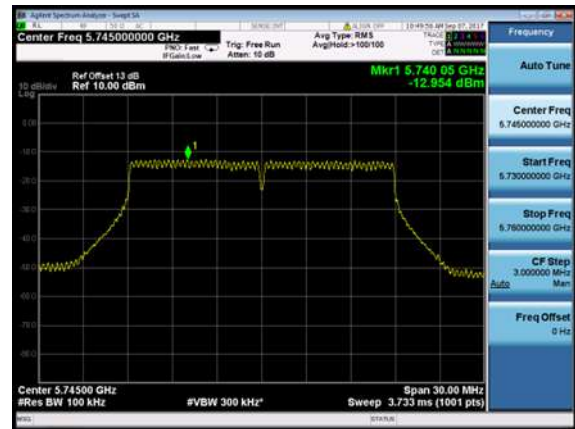

Channel 157 (5785MHz)

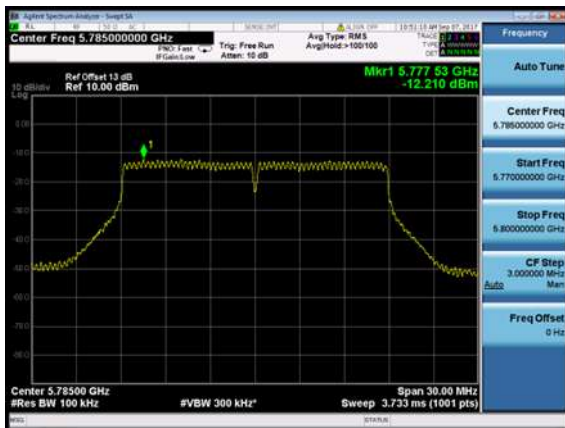

Channel 165 (5825MHz)

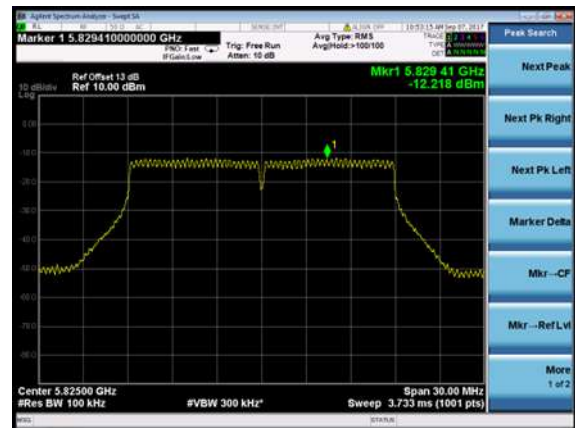



802.11n(40MHz) Power Spectral Density

Channel 38 (5190MHz)

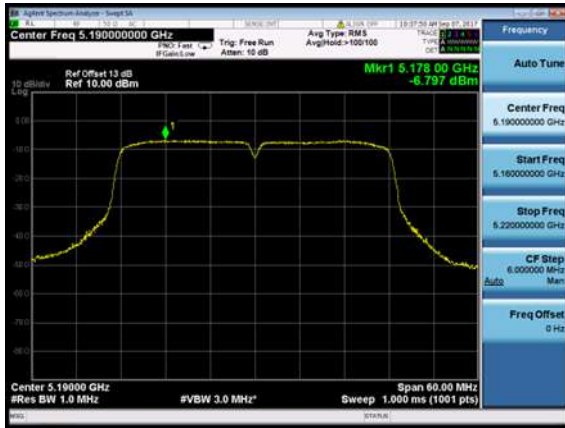

Channel 46 (5230MHz)

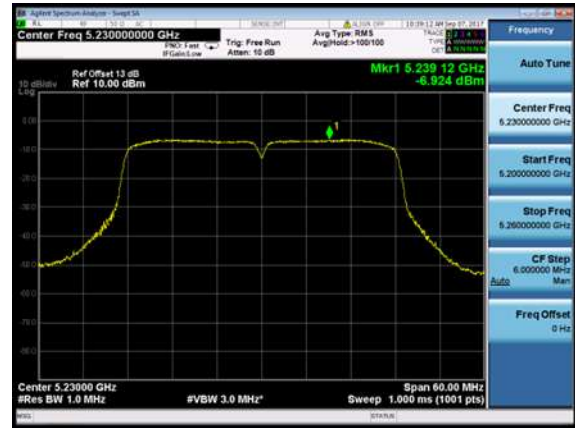

Channel 155 (5755MHz)

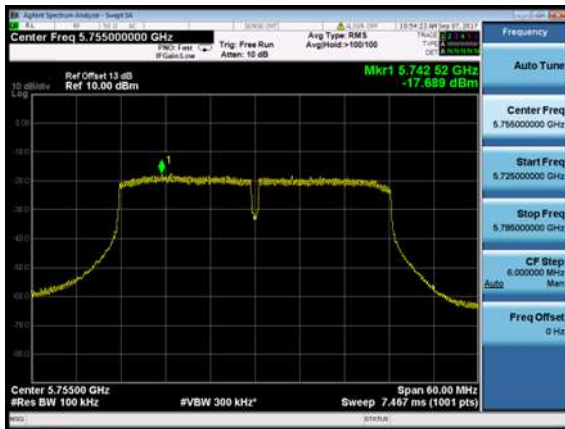

Channel 159 (5795MHz)

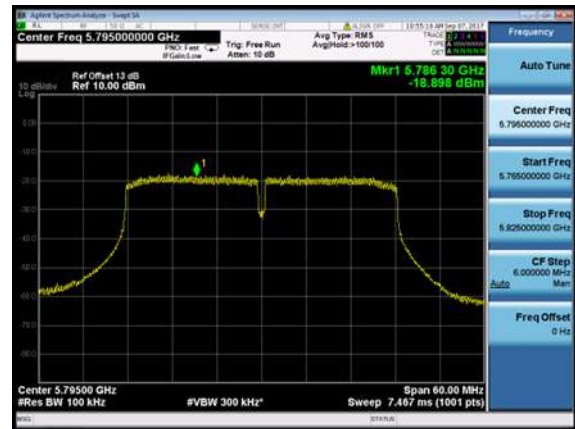



802.11ac(80MHz) Power Spectral Density

Channel 42 (5210MHz)

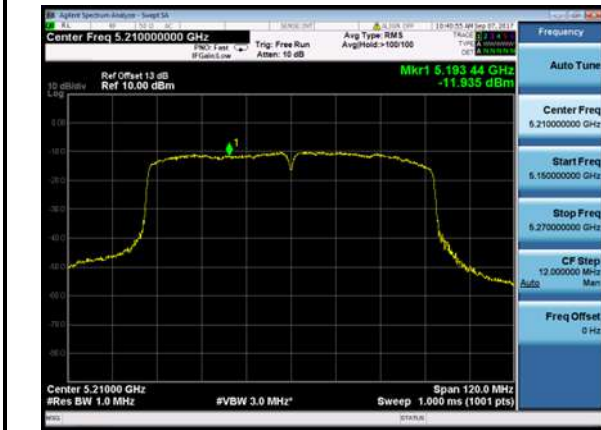

Channel 155 (5775MHz)

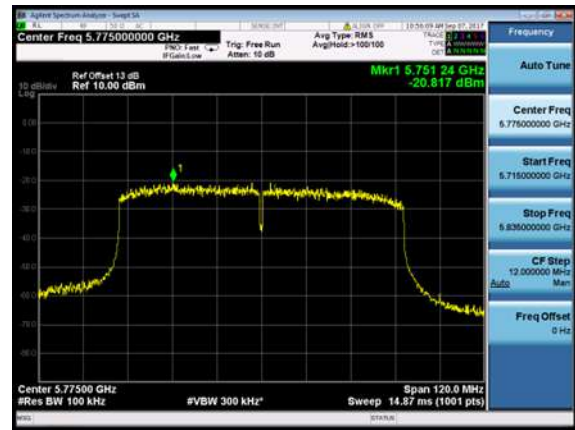



9. Band Edges Measurement

9.1 Test Limit

For 15.205 requirement:

Radiated emissions which fall in the restricted bands, as defined in Section 15.205(a) of FCC part 15, must also comply with the radiated emission limits specified in Section 15.209(a).

MHz	MHz	MHz	GHz
0.090 - 0.110	16.42 - 16.423	399.9 - 410	4.5 - 5.15
¹ 0.495 - 0.505	16.69475 - 16.69525	608 - 614	5.35 - 5.46
2.1735 - 2.1905	16.80425 - 16.80475	960 - 1240	7.25 - 7.75
4.125 - 4.128	25.5 - 25.67	1300 - 1427	8.025 - 8.5
4.17725 - 4.17775	37.5 - 38.25	1435 - 1626.5	9.0 - 9.2
4.20725 - 4.20775	73 - 74.6	1645.5 - 1646.5	9.3 - 9.5
6.215 - 6.218	74.8 - 75.2	1660 - 1710	10.6 - 12.7
6.26775 - 6.26825	108 - 121.94	1718.8 - 1722.2	13.25 - 13.4
6.31175 - 6.31225	123 - 138	2200 - 2300	14.47 - 14.5
8.291 - 8.294	149.9 - 150.05	2310 - 2390	15.35 - 16.2
8.362 - 8.366	156.52475 - 156.52525	2483.5 - 2500	17.7 - 21.4
8.37625 - 8.38675	156.7 - 156.9	2690 - 2900	22.01 - 23.12
8.41425 - 8.41475	162.0125 - 167.17	3260 - 3267	23.6 - 24.0
12.29 - 12.293	167.72 - 173.2	3332 - 3339	31.2 - 31.8
12.51975 - 12.52025	240 - 285	3345.8 - 3358	36.43 - 36.5
12.57675 - 12.57725	322 - 335.4	3600 - 4400	(²)

**For 15.407(b) requirement:**

For transmitters operating in the 5.15-5.25 GHz band: all emissions outside of the 5.15-5.35 GHz band shall not exceed an EIRP of -27 dBm/MHz.

Operating Frequency Band (MHz)	EIRP Limit (dBm/MHz)	Equivalent Field Strength at 3m (dBuV/m)
5150 - 5350	-27	68.2
5470 - 5725	-27	68.2

For transmitters operating in the 5.725-5.85 GHz band:

All emissions shall be limited to a level of -27 dBm/MHz at 75 MHz or more above or below the band edge increasing linearly to 10 dBm/MHz at 25 MHz above or below the band edge, and from 25 MHz above or below the band edge increasing linearly to a level of 15.6 dBm/MHz at 5 MHz above or below the band edge, and from 5 MHz above or below the band edge increasing linearly to a level of 27 dBm/MHz at the band edge.

Note:

1. Refer to KDB 789033 D02v01r04 G)2)c), as specified in § 15.407(b)(1)-(3) specifies that emissions outside of the respective U-NII bands are subject to a maximum emission limit of -27 dBm/MHz. § 15.407(b)(4) provides two requirement options for devices that operate in the 5.725 – 5.85 GHz band. If the option specified in § 15.407(b)(4)(ii) is exercised, then the procedures specified in Clause 11.11 of ANSI C63.10-2013 and/or in Section 11.0 of KDB Publication 558074 shall be utilized. In general, an out-of-band emission that complies with both the peak and average power limits of § 15.209 is not required to also satisfy the -27 dBm/MHz or -17 dBm/MHz maximum emission limit.
2. All out of band emissions appearing in a restricted band as specified in Section 15.205 of the Title 47 CFR must not exceed the limits shown in Table per Section 15.209.

FCC Part 15 Subpart C Paragraph 15.209		
Frequency [MHz]	Field Strength [V/m]	Measured Distance [Meters]
0.009 – 0.490	2400/F (kHz)	300
0.490 – 1.705	24000/F (kHz)	30
1.705 - 30	30	30
30 - 88	100	3
88 - 216	200	3
216 - 960	200	3
Above 960	500	3



9.2 Test Standard

KDB 789033 D02v01r04 G)2)c)

9.3 Test Procedures

Peak Field Strength Measurements:

Analyzer center frequency was set to the frequency of the radiated spurious emission of interest

1. RBW = 1MHz
2. VBW = 3MHz
3. Detector = peak
4. Sweep time = auto couple
5. Trace mode = max hold
6. Trace was allowed to stabilize

AVE Field Strength Measurements:

(i) RBW = 1 MHz.

(ii) Video bandwidth.

■ If the EUT is configured to transmit with duty cycle $\geq 98\%$, set VBW \leq RBW/100 (i.e., 10 kHz) but not less than 10 Hz.

■ If the EUT duty cycle is $< 98\%$, set VBW $\geq 1/T$, where T is defined in section II.B.1.a).

(iii) Video bandwidth mode or display mode

■ The instrument shall be set to ensure that video filtering is applied in the power domain. Typically, this requires setting the detector mode to rms and setting the Average-VBW Type to power averaging (rms).

■ As an alternative, the analyzer may be set to linear detector mode. Ensure that video filtering is applied in linear voltage domain (rather than in a log or dB domain). Some analyzers require linear display mode in order to accomplish this. Others have a setting for Average-VBW Type, which can be set to "Voltage" regardless of the display mode.

(iv) Detector = Peak.

(v) Sweep time = auto.

(vi) Trace mode = max hold.

(vii) Allow max hold to run for at least 50 traces if the transmitted signal is continuous or has at least 98% duty cycle. For lower duty cycles, increase the minimum number of traces by a factor of $1/x$, where x is the duty cycle. For example, use at least 200 traces if the duty cycle is 25%. (If a specific emission is demonstrated to be continuous—i.e., 100% duty cycle—rather than turning on and off with the transmit cycle, at least 50 traces shall be averaged.)



9.4 Test Setup

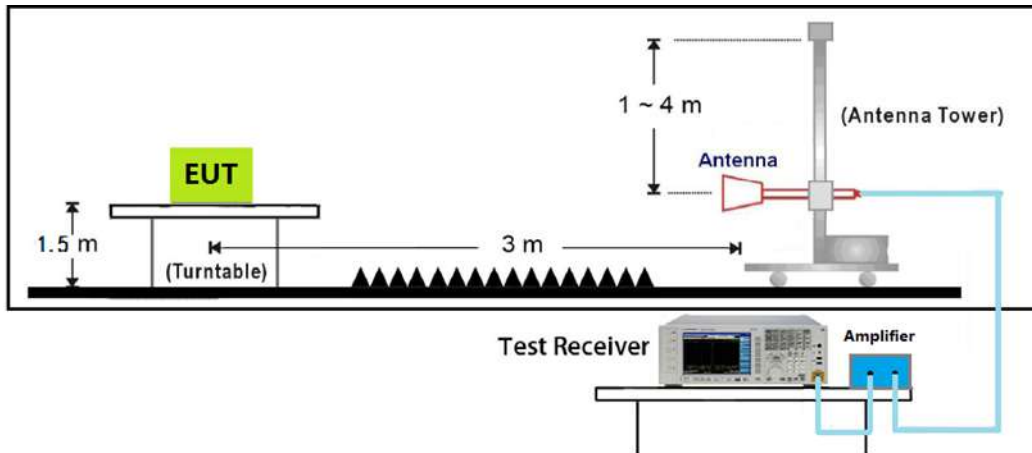



9.5 Test Result and Data

Site: AC102	Time: 2017/09/07 - 19:48
Limit: FCC_Part15.209_RE(3m)	Margin: 0
Probe: N/A	Polarity: Horizontal
EUT: Touch All in one Computer	Power: AC 120V/60Hz
Note: Mode: Transmit 802.11a at 5180MHz	

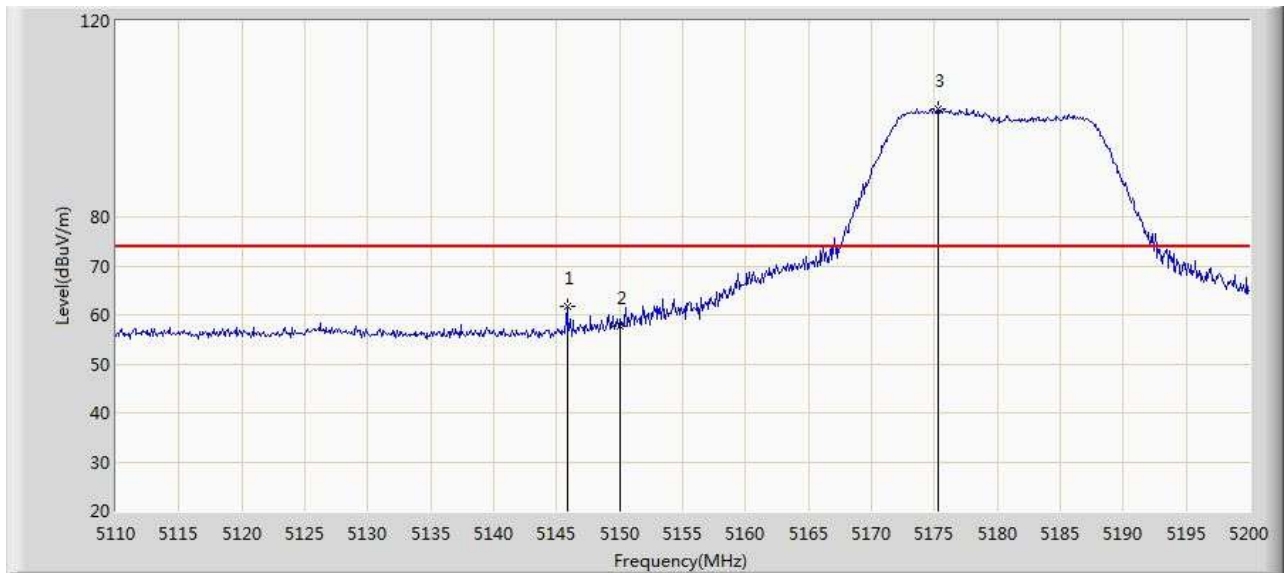

No	Mark	Frequency (MHz)	Measure Level (dBuV/m)	Reading Level (dBuV)	Over Limit (dB)	Limit (dBuV/m)	Factor (dB)	Type
1		5145.820	61.867	57.751	-12.133	74.000	4.116	PK
2		5150.000	57.818	53.689	-16.182	74.000	4.129	PK
3	*	5175.340	102.056	97.849	N/A	N/A	4.207	PK

Note: Measure Level (dBμV/m) = Reading Level (dBμV) + Factor (dB)

Factor (dB) = Cable Loss (dB) + Antenna Factor (dB/m).



Site: AC102	Time: 2017/09/07 - 19:55
Limit: FCC_Part15.209_RE(3m)	Margin: 0
Probe: N/A	Polarity: Horizontal
EUT: Touch All in one Computer	Power: AC 120V/60Hz
Note: Mode:Transmit 802.11a at 5180MHz	

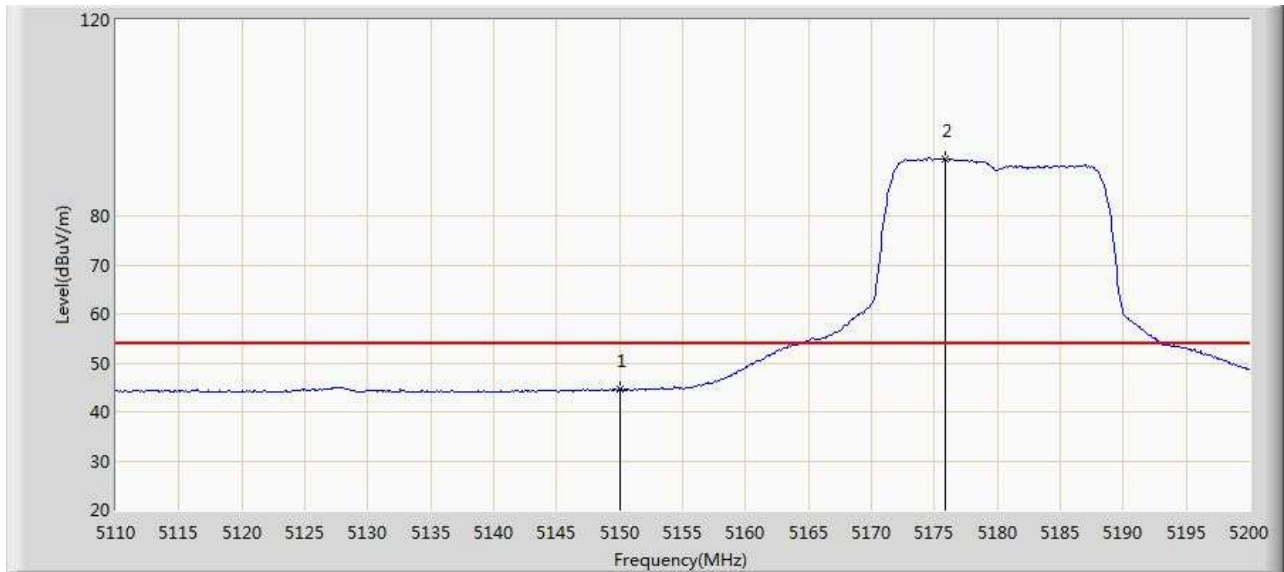

No	Mark	Frequency (MHz)	Measure Level (dBuV/m)	Reading Level (dBuV)	Over Limit (dB)	Limit (dBuV/m)	Factor (dB)	Type
1		5150.000	44.548	40.419	-9.452	54.000	4.129	AV
2	*	5175.880	91.613	87.405	N/A	N/A	4.208	AV

Note: Measure Level (dBuV/m) = Reading Level (dBuV) + Factor (dB)

Factor (dB) = Cable Loss (dB) + Antenna Factor (dB/m).



Site: AC102	Time: 2017/09/07 - 19:57
Limit: FCC_Part15.209_RE(3m)	Margin: 0
Probe: N/A	Polarity: Vertical
EUT: Touch All in one Computer	Power: AC 120V/60Hz
Note: Mode:Transmit 802.11a at 5180MHz	

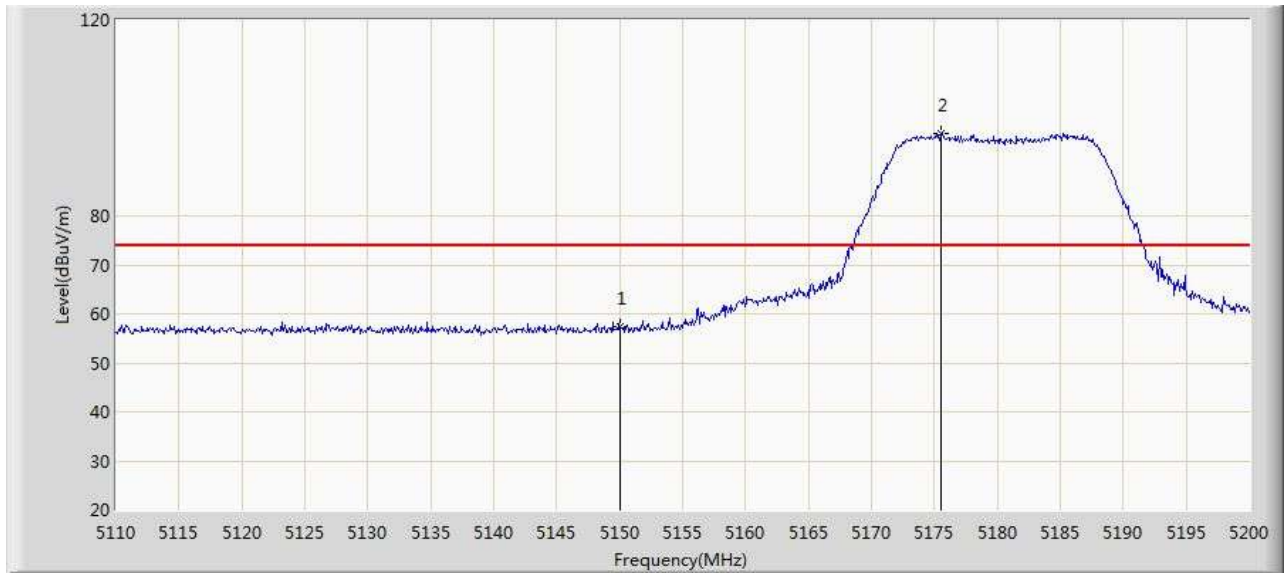

No	Mark	Frequency (MHz)	Measure Level (dBuV/m)	Reading Level (dBuV)	Over Limit (dB)	Limit (dBuV/m)	Factor (dB)	Type
1		5150.000	57.305	53.176	-16.695	74.000	4.129	PK
2	*	5175.520	96.857	92.650	N/A	N/A	4.207	PK

Note: Measure Level (dBuV/m) = Reading Level (dBuV) + Factor (dB)

Factor (dB) = Cable Loss (dB) + Antenna Factor (dB/m).



Site: AC102	Time: 2017/09/07 - 20:10
Limit: FCC_Part15.209_RE(3m)	Margin: 0
Probe: N/A	Polarity: Vertical
EUT: Touch All in one Computer	Power: AC 120V/60Hz
Note: Mode:Transmit 802.11a at 5180MHz	

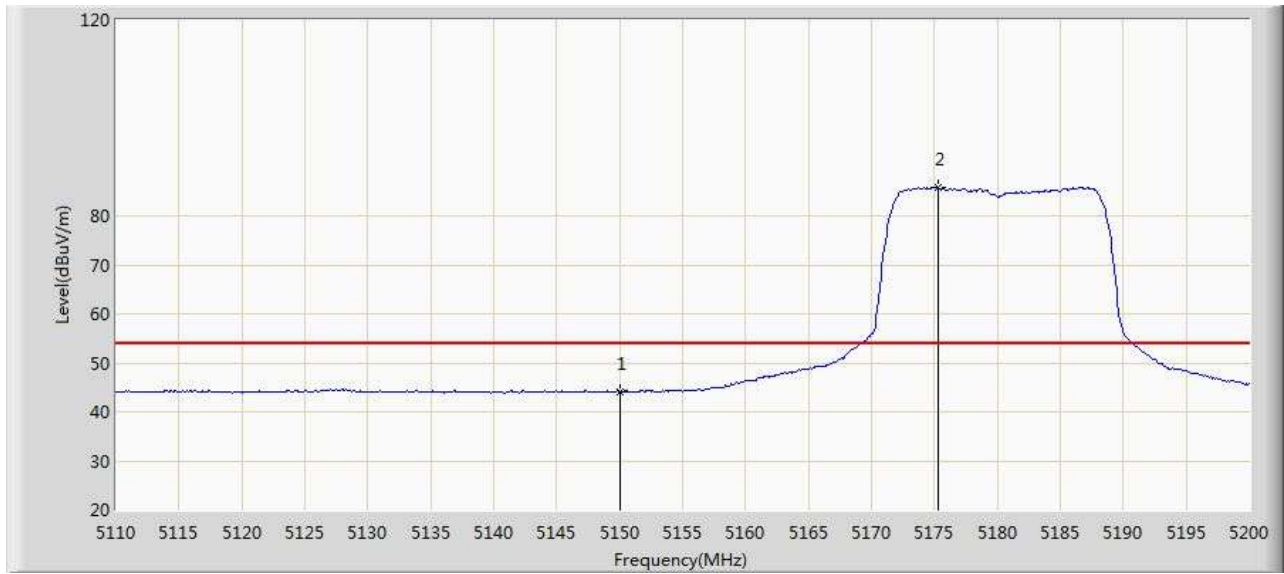

No	Mark	Frequency (MHz)	Measure Level (dBuV/m)	Reading Level (dBuV)	Over Limit (dB)	Limit (dBuV/m)	Factor (dB)	Type
1		5150.000	44.059	39.930	-9.941	54.000	4.129	AV
2	*	5175.340	85.714	81.507	N/A	N/A	4.207	AV

Note: Measure Level (dBuV/m) = Reading Level (dBuV) + Factor (dB)

Factor (dB) = Cable Loss (dB) + Antenna Factor (dB/m).



Site: AC102	Time: 2017/09/07 - 20:10
Limit: FCC_Part15.209_RE(3m)	Margin: 0
Probe: N/A	Polarity: Vertical
EUT: Touch All in one Computer	Power: AC 120V/60Hz
Note: Mode:Transmit 802.11a at 5240MHz	

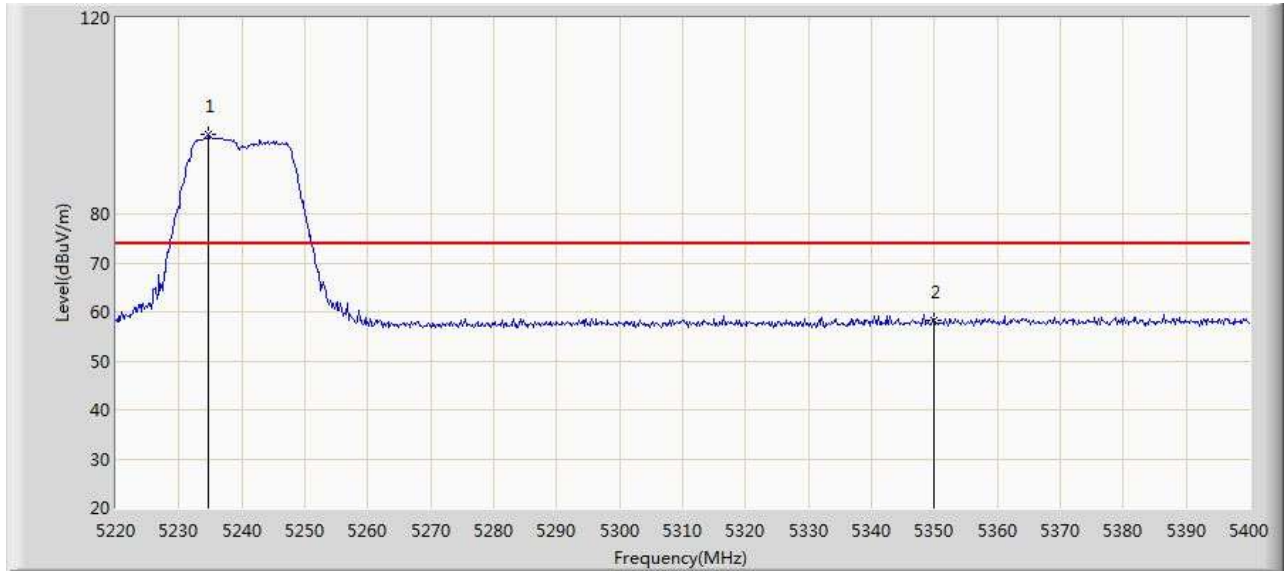

No	Mark	Frequency (MHz)	Measure Level (dBuV/m)	Reading Level (dBuV)	Over Limit (dB)	Limit (dBuV/m)	Factor (dB)	Type
1	*	5234.760	96.255	91.867	N/A	N/A	4.388	PK
2		5350.000	58.237	53.496	-15.763	74.000	4.741	PK

Note: Measure Level (dBuV/m) = Reading Level (dBuV) + Factor (dB)

Factor (dB) = Cable Loss (dB) + Antenna Factor (dB/m).



Site: AC102	Time: 2017/09/07 - 20:17
Limit: FCC_Part15.209_RE(3m)	Margin: 0
Probe: N/A	Polarity: Vertical
EUT: Touch All in one Computer	Power: AC 120V/60Hz
Note: Mode:Transmit 802.11a at 5240MHz	

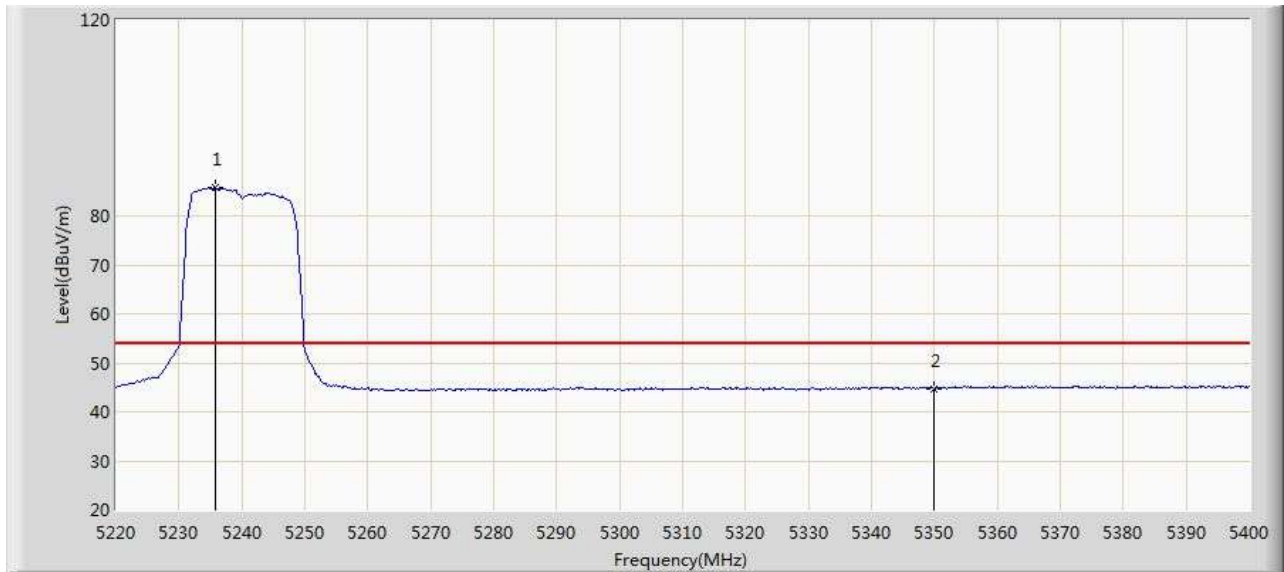

No	Mark	Frequency (MHz)	Measure Level (dBuV/m)	Reading Level (dBuV)	Over Limit (dB)	Limit (dBuV/m)	Factor (dB)	Type
1	*	5235.840	85.693	81.301	N/A	N/A	4.392	AV
2		5350.000	44.685	39.944	-9.315	54.000	4.741	AV

Note: Measure Level (dBuV/m) = Reading Level (dBuV) + Factor (dB)

Factor (dB) = Cable Loss (dB) + Antenna Factor (dB/m).



Site: AC102	Time: 2017/09/07 - 20:18
Limit: FCC_Part15.209_RE(3m)	Margin: 0
Probe: N/A	Polarity: Horizontal
EUT: Touch All in one Computer	Power: AC 120V/60Hz
Note: Mode:Transmit 802.11a at 5240MHz	



No	Mark	Frequency (MHz)	Measure Level (dBuV/m)	Reading Level (dBuV)	Over Limit (dB)	Limit (dBuV/m)	Factor (dB)	Type
1	*	5235.120	102.598	98.209	N/A	N/A	4.389	PK
2		5350.000	57.625	52.884	-16.375	74.000	4.741	PK

Note: Measure Level (dBuV/m) = Reading Level (dBuV) + Factor (dB)

Factor (dB) = Cable Loss (dB) + Antenna Factor (dB/m).



Site: AC102	Time: 2017/09/07 - 20:22
Limit: FCC_Part15.209_RE(3m)	Margin: 0
Probe: N/A	Polarity: Horizontal
EUT: Touch All in one Computer	Power: AC 120V/60Hz
Note: Mode:Transmit 802.11a at 5240MHz	

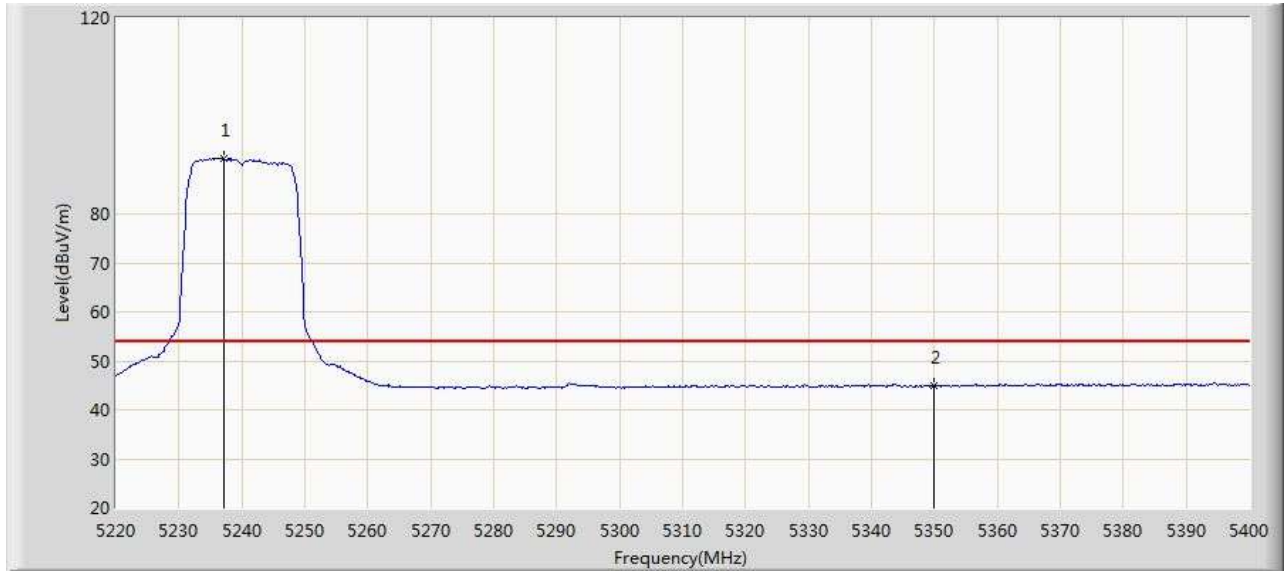

No	Mark	Frequency (MHz)	Measure Level (dBuV/m)	Reading Level (dBuV)	Over Limit (dB)	Limit (dBuV/m)	Factor (dB)	Type
1	*	5237.100	91.394	86.998	N/A	N/A	4.396	AV
2		5350.000	44.897	40.156	-9.103	54.000	4.741	AV

Note: Measure Level (dBuV/m) = Reading Level (dBuV) + Factor (dB)

Factor (dB) = Cable Loss (dB) + Antenna Factor (dB/m).



Site: AC102	Time: 2017/09/07 - 20:23
Limit: FCC_Part15.209_RE(3m)	Margin: 0
Probe: N/A	Polarity: Horizontal
EUT: Touch All in one Computer	Power: AC 120V/60Hz
Note: Mode:Transmit 802.11n20 at 5180MHz	

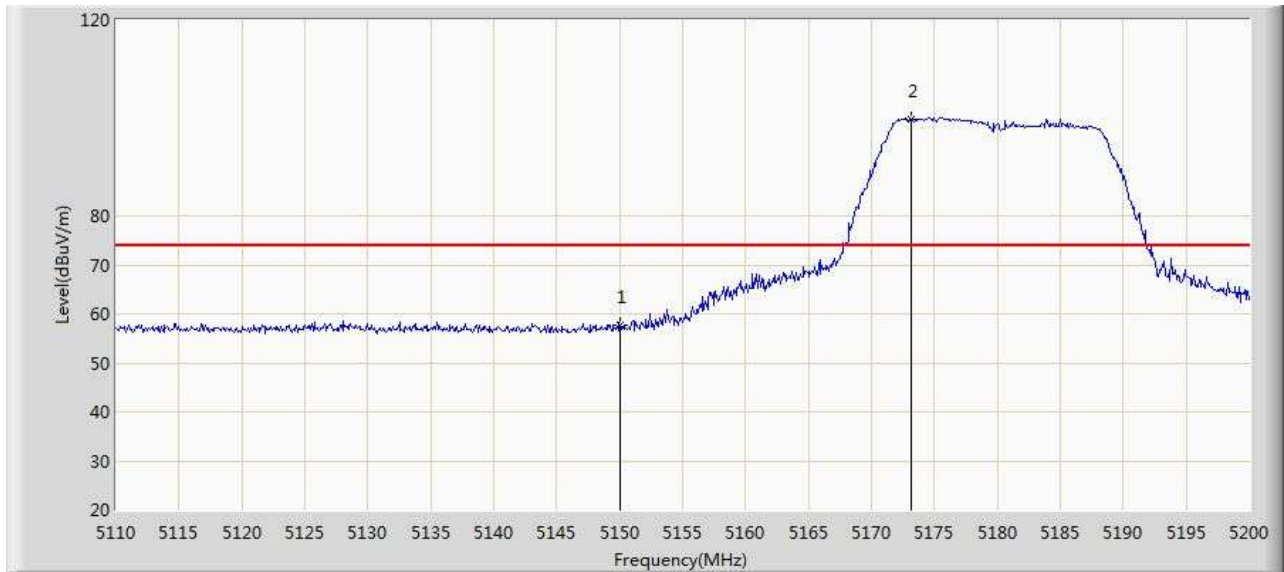

No	Mark	Frequency (MHz)	Measure Level (dBuV/m)	Reading Level (dBuV)	Over Limit (dB)	Limit (dBuV/m)	Factor (dB)	Type
1		5150.000	57.713	53.584	-16.287	74.000	4.129	PK
2	*	5173.180	99.781	95.581	N/A	N/A	4.200	PK

Note: Measure Level (dBuV/m) = Reading Level (dBuV) + Factor (dB)

Factor (dB) = Cable Loss (dB) + Antenna Factor (dB/m).



Site: AC102	Time: 2017/09/07 - 20:26
Limit: FCC_Part15.209_RE(3m)	Margin: 0
Probe: N/A	Polarity: Horizontal
EUT: Touch All in one Computer	Power: AC 120V/60Hz
Note: Mode:Transmit 802.11n20 at 5180MHz	

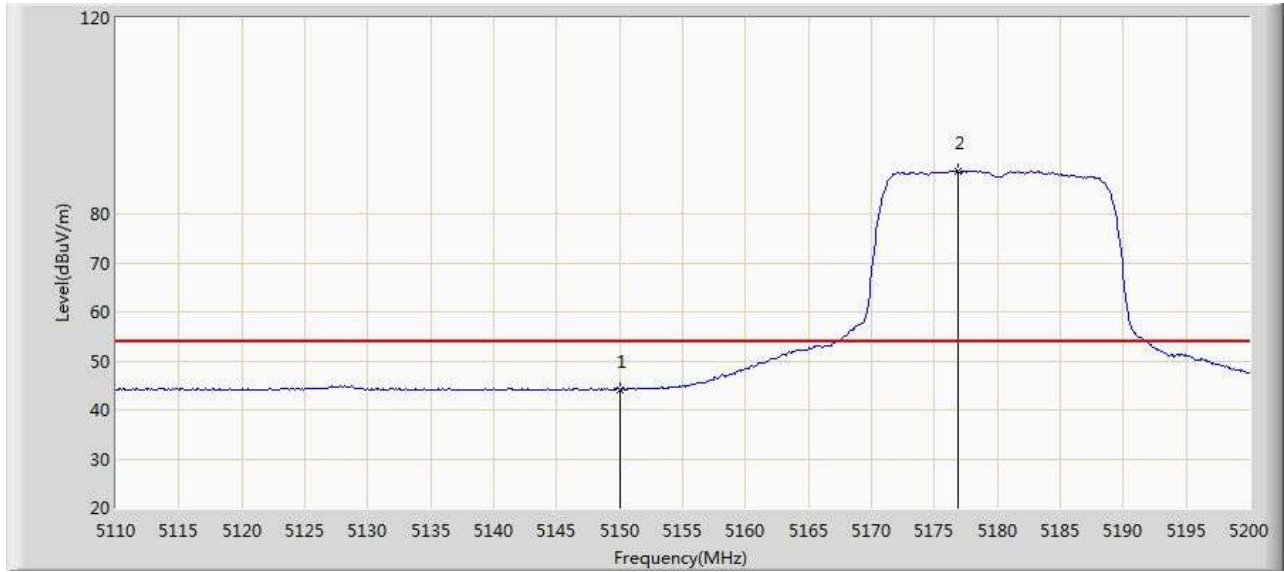

No	Mark	Frequency (MHz)	Measure Level (dBuV/m)	Reading Level (dBuV)	Over Limit (dB)	Limit (dBuV/m)	Factor (dB)	Type
1		5150.000	44.198	40.069	-9.802	54.000	4.129	AV
2	*	5176.870	88.665	84.454	N/A	N/A	4.211	AV

Note: Measure Level (dBuV/m) = Reading Level (dBuV) + Factor (dB)

Factor (dB) = Cable Loss (dB) + Antenna Factor (dB/m).



Site: AC102	Time: 2017/09/07 - 20:27
Limit: FCC_Part15.209_RE(3m)	Margin: 0
Probe: N/A	Polarity: Vertical
EUT: Touch All in one Computer	Power: AC 120V/60Hz
Note: Mode:Transmit 802.11n20 at 5180MHz	

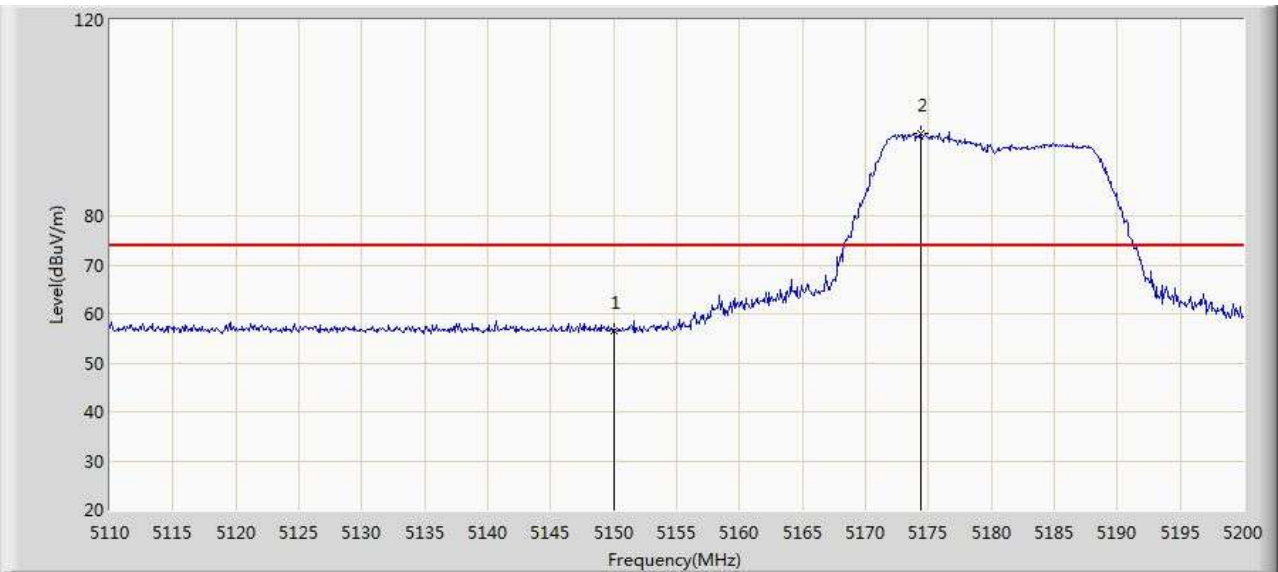

No	Mark	Frequency (MHz)	Measure Level (dBuV/m)	Reading Level (dBuV)	Over Limit (dB)	Limit (dBuV/m)	Factor (dB)	Type
1		5150.000	56.540	52.411	-17.460	74.000	4.129	PK
2	*	5174.440	96.786	92.582	N/A	N/A	4.204	PK

Note: Measure Level (dBuV/m) = Reading Level (dBuV) + Factor (dB)

Factor (dB) = Cable Loss (dB) + Antenna Factor (dB/m).



Site: AC102	Time: 2017/09/07 - 20:30
Limit: FCC_Part15.209_RE(3m)	Margin: 0
Probe: N/A	Polarity: Vertical
EUT: Touch All in one Computer	Power: AC 120V/60Hz
Note: Mode:Transmit 802.11n20 at 5180MHz	



No	Mark	Frequency (MHz)	Measure Level (dBuV/m)	Reading Level (dBuV)	Over Limit (dB)	Limit (dBuV/m)	Factor (dB)	Type
1		5150.000	44.216	40.087	-9.784	54.000	4.129	AV
2	*	5174.710	85.109	80.904	N/A	N/A	4.205	AV

Note: Measure Level (dBuV/m) = Reading Level (dBuV) + Factor (dB)

Factor (dB) = Cable Loss (dB) + Antenna Factor (dB/m).



Site: AC102	Time: 2017/09/07 - 20:31
Limit: FCC_Part15.209_RE(3m)	Margin: 0
Probe: N/A	Polarity: Vertical
EUT: Touch All in one Computer	Power: AC 120V/60Hz
Note: Mode:Transmit 802.11n20 at 5240MHz	

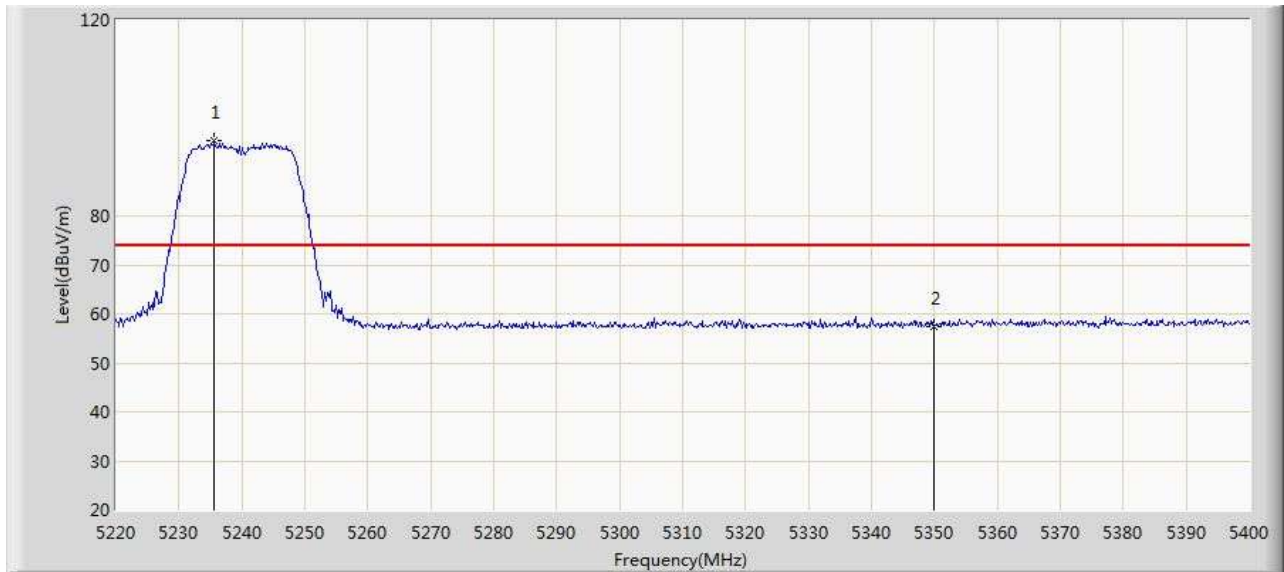

No	Mark	Frequency (MHz)	Measure Level (dBuV/m)	Reading Level (dBuV)	Over Limit (dB)	Limit (dBuV/m)	Factor (dB)	Type
1	*	5235.660	95.258	90.867	N/A	N/A	4.391	PK
2		5350.000	57.515	52.774	-16.485	74.000	4.741	PK

Note: Measure Level (dBuV/m) = Reading Level (dBuV) + Factor (dB)

Factor (dB) = Cable Loss (dB) + Antenna Factor (dB/m).



Site: AC102	Time: 2017/09/07 - 20:36
Limit: FCC_Part15.209_RE(3m)	Margin: 0
Probe: N/A	Polarity: Vertical
EUT: Touch All in one Computer	Power: AC 120V/60Hz
Note: Mode:Transmit 802.11n20 at 5240MHz	

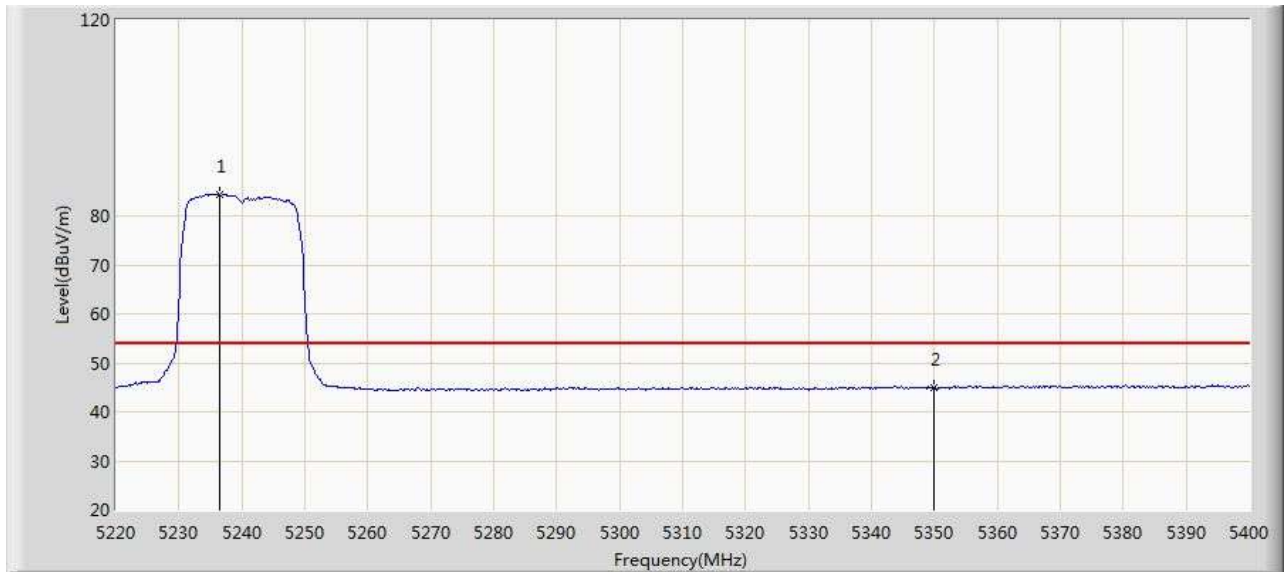

No	Mark	Frequency (MHz)	Measure Level (dBuV/m)	Reading Level (dBuV)	Over Limit (dB)	Limit (dBuV/m)	Factor (dB)	Type
1	*	5236.560	84.261	79.867	N/A	N/A	4.394	AV
2		5350.000	44.866	40.125	-9.134	54.000	4.741	AV

Note: Measure Level (dBuV/m) = Reading Level (dBuV) + Factor (dB)

Factor (dB) = Cable Loss (dB) + Antenna Factor (dB/m).



Site: AC102	Time: 2017/09/07 - 20:37
Limit: FCC_Part15.209_RE(3m)	Margin: 0
Probe: N/A	Polarity: Horizontal
EUT: Touch All in one Computer	Power: AC 120V/60Hz
Note: Mode:Transmit 802.11n20 at 5240MHz	

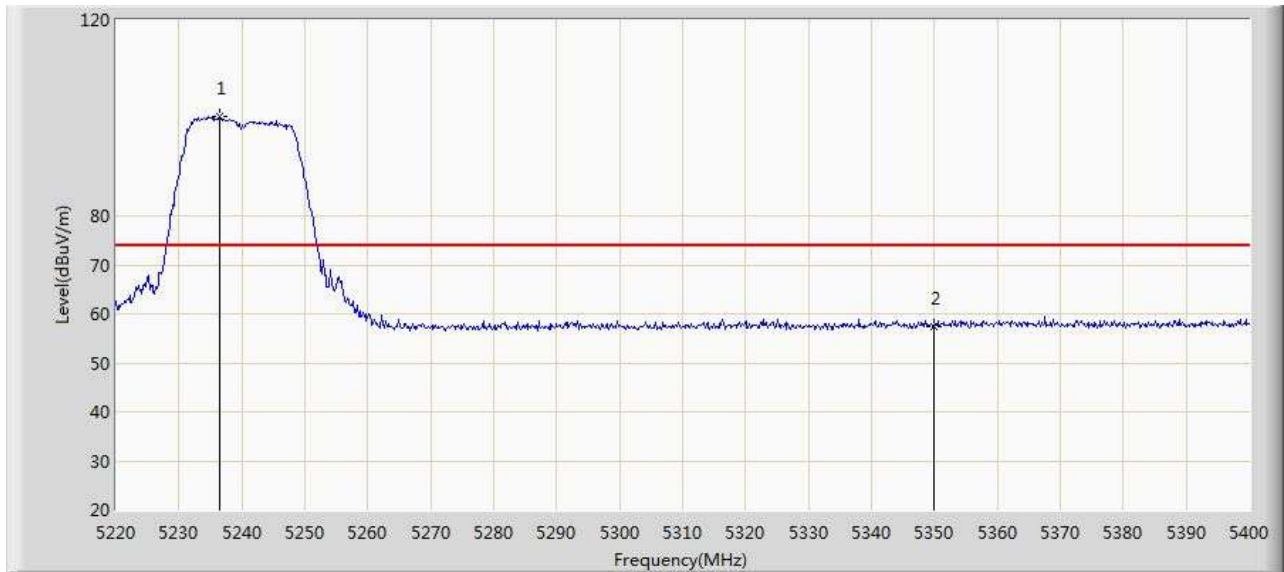

No	Mark	Frequency (MHz)	Measure Level (dBuV/m)	Reading Level (dBuV)	Over Limit (dB)	Limit (dBuV/m)	Factor (dB)	Type
1	*	5236.380	100.424	96.031	N/A	N/A	4.393	PK
2		5350.000	57.500	52.759	-16.500	74.000	4.741	PK

Note: Measure Level (dBuV/m) = Reading Level (dBuV) + Factor (dB)

Factor (dB) = Cable Loss (dB) + Antenna Factor (dB/m).



Site: AC102	Time: 2017/09/07 - 20:40
Limit: FCC_Part15.209_RE(3m)	Margin: 0
Probe: N/A	Polarity: Horizontal
EUT: Touch All in one Computer	Power: AC 120V/60Hz
Note: Mode:Transmit 802.11n20 at 5240MHz	

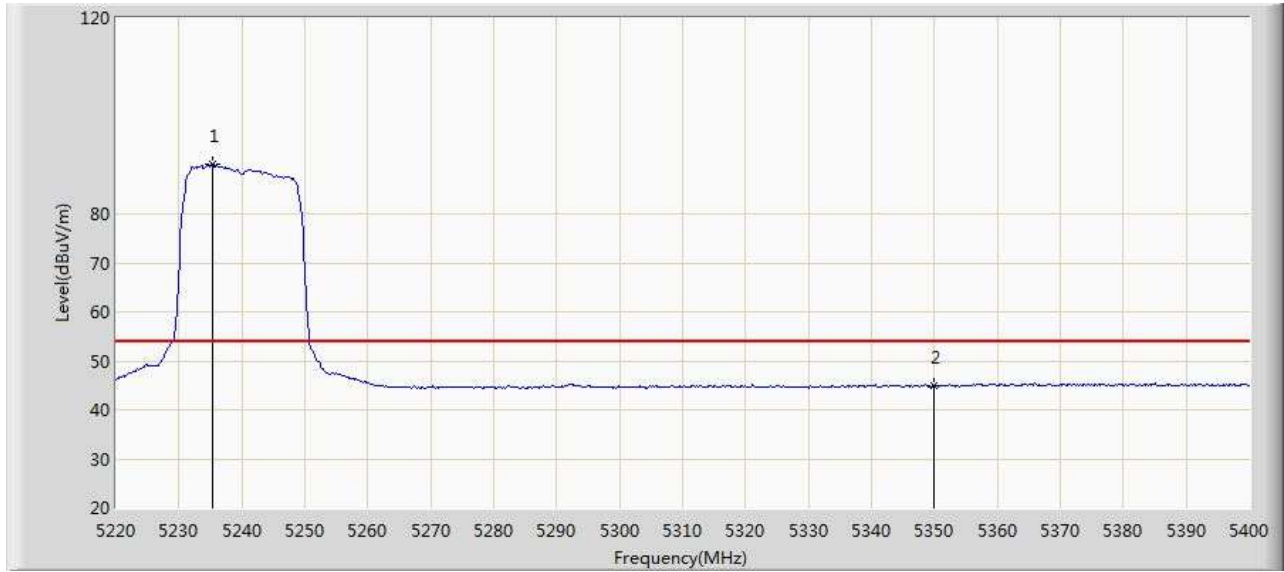

No	Mark	Frequency (MHz)	Measure Level (dBuV/m)	Reading Level (dBuV)	Over Limit (dB)	Limit (dBuV/m)	Factor (dB)	Type
1	*	5235.300	90.061	85.671	N/A	N/A	4.390	AV
2		5350.000	44.999	40.258	-9.001	54.000	4.741	AV

Note: Measure Level (dBuV/m) = Reading Level (dBuV) + Factor (dB)

Factor (dB) = Cable Loss (dB) + Antenna Factor (dB/m).



Site: AC102	Time: 2017/09/07 - 20:41
Limit: FCC_Part15.209_RE(3m)	Margin: 0
Probe: N/A	Polarity: Horizontal
EUT: Touch All in one Computer	Power: AC 120V/60Hz
Note: Mode:Transmit 802.11n40 at 5190MHz	

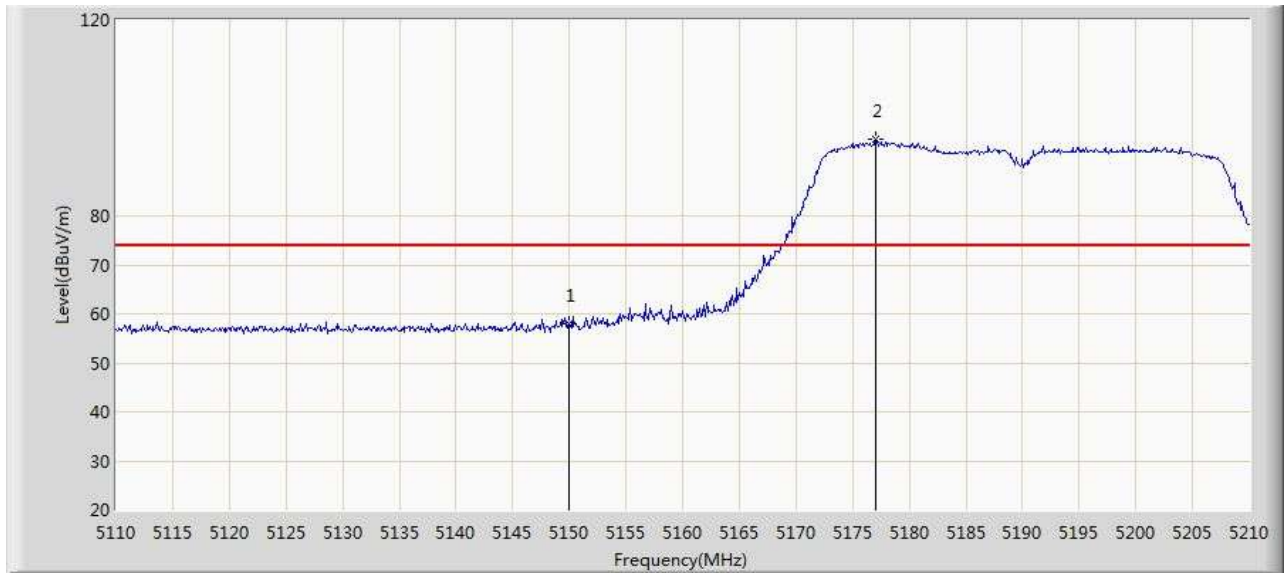

No	Mark	Frequency (MHz)	Measure Level (dBuV/m)	Reading Level (dBuV)	Over Limit (dB)	Limit (dBuV/m)	Factor (dB)	Type
1		5150.000	57.986	53.857	-16.014	74.000	4.129	PK
2	*	5177.000	95.593	91.381	N/A	N/A	4.212	PK

Note: Measure Level (dBuV/m) = Reading Level (dBuV) + Factor (dB)

Factor (dB) = Cable Loss (dB) + Antenna Factor (dB/m).



Site: AC102	Time: 2017/09/07 - 20:45
Limit: FCC_Part15.209_RE(3m)	Margin: 0
Probe: N/A	Polarity: Horizontal
EUT: Touch All in one Computer	Power: AC 120V/60Hz
Note: Mode:Transmit 802.11n40 at 5190MHz	

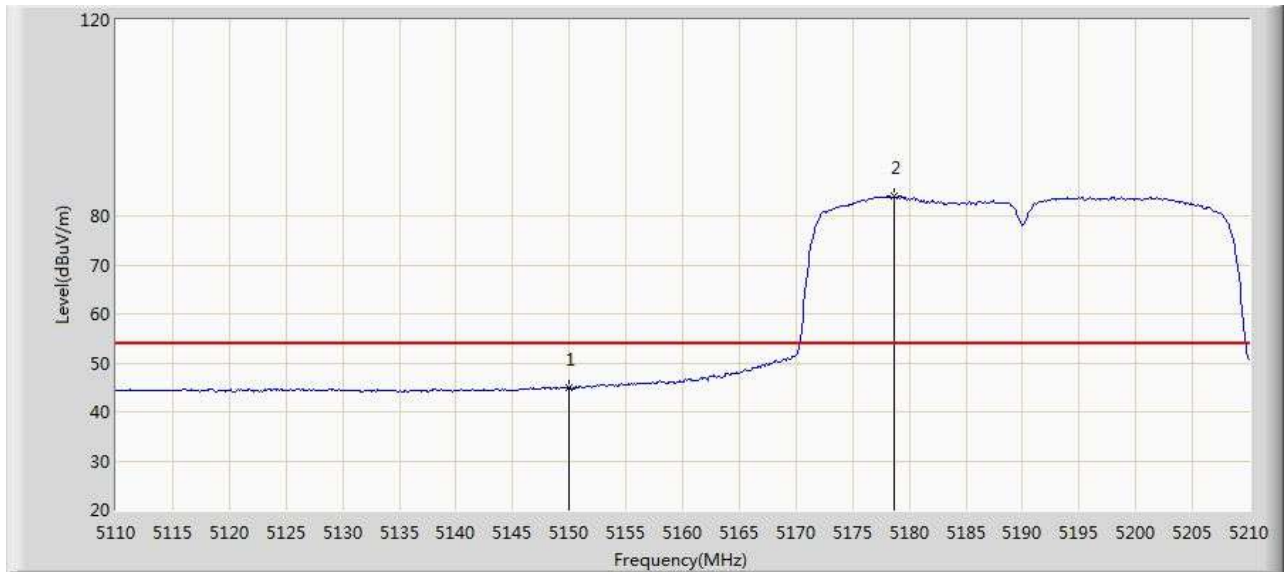

No	Mark	Frequency (MHz)	Measure Level (dBuV/m)	Reading Level (dBuV)	Over Limit (dB)	Limit (dBuV/m)	Factor (dB)	Type
1		5150.000	45.052	40.923	-8.948	54.000	4.129	AV
2	*	5178.700	84.008	79.791	N/A	N/A	4.217	AV

Note: Measure Level (dBuV/m) = Reading Level (dBuV) + Factor (dB)

Factor (dB) = Cable Loss (dB) + Antenna Factor (dB/m).



Site: AC102	Time: 2017/09/07 - 20:45
Limit: FCC_Part15.209_RE(3m)	Margin: 0
Probe: N/A	Polarity: Vertical
EUT: Touch All in one Computer	Power: AC 120V/60Hz
Note: Mode:Transmit 802.11n40 at 5190MHz	

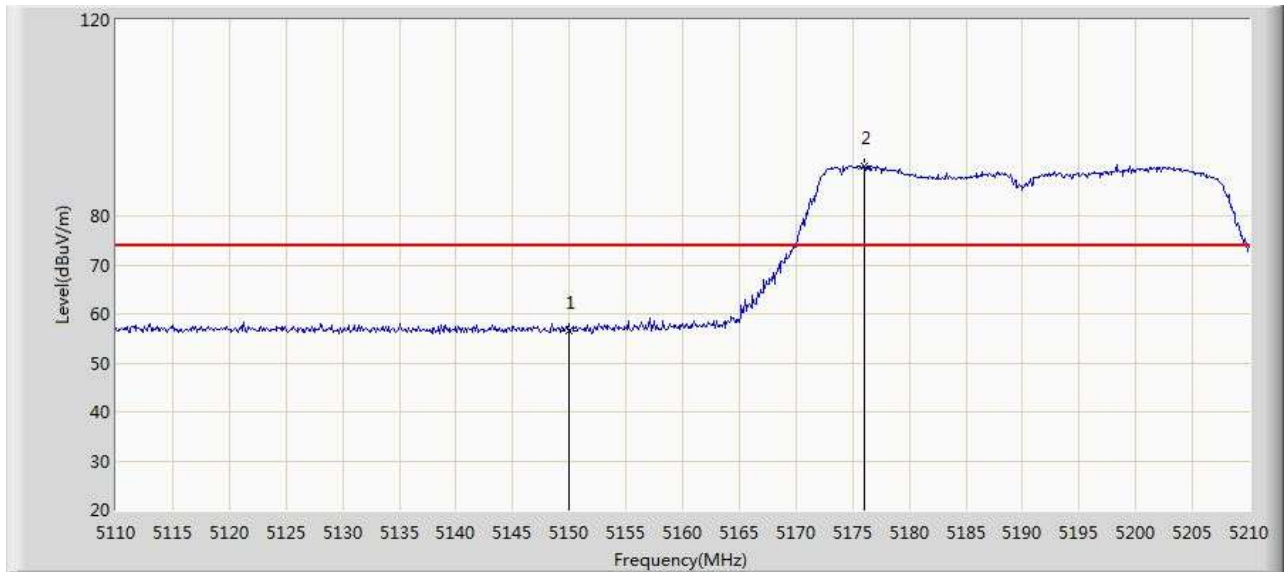

No	Mark	Frequency (MHz)	Measure Level (dBuV/m)	Reading Level (dBuV)	Over Limit (dB)	Limit (dBuV/m)	Factor (dB)	Type
1		5150.000	56.665	52.536	-17.335	74.000	4.129	PK
2	*	5176.000	90.097	85.888	N/A	N/A	4.209	PK

Note: Measure Level (dBuV/m) = Reading Level (dBuV) + Factor (dB)

Factor (dB) = Cable Loss (dB) + Antenna Factor (dB/m).



Site: AC102	Time: 2017/09/07 - 20:48
Limit: FCC_Part15.209_RE(3m)	Margin: 0
Probe: N/A	Polarity: Vertical
EUT: Touch All in one Computer	Power: AC 120V/60Hz
Note: Mode:Transmit 802.11n40 at 5190MHz	

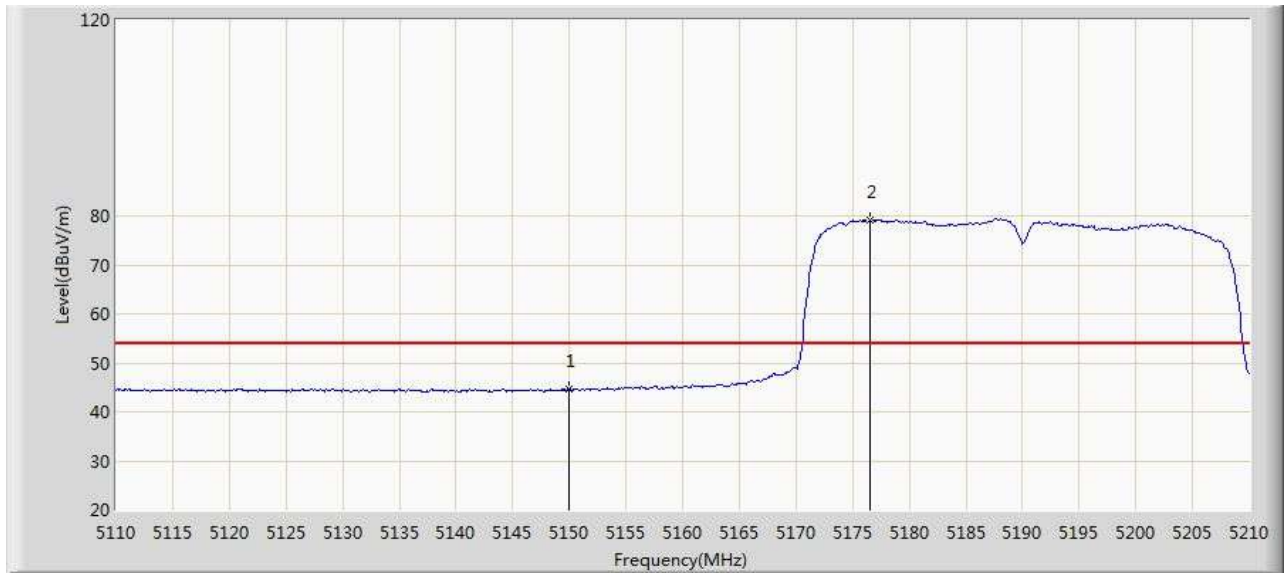

No	Mark	Frequency (MHz)	Measure Level (dBuV/m)	Reading Level (dBuV)	Over Limit (dB)	Limit (dBuV/m)	Factor (dB)	Type
1		5150.000	44.782	40.653	-9.218	54.000	4.129	AV
2	*	5176.600	79.227	75.017	N/A	N/A	4.210	AV

Note: Measure Level (dBuV/m) = Reading Level (dBuV) + Factor (dB)

Factor (dB) = Cable Loss (dB) + Antenna Factor (dB/m).



Site: AC102	Time: 2017/09/07 - 20:49
Limit: FCC_Part15.209_RE(3m)	Margin: 0
Probe: N/A	Polarity: Vertical
EUT: Touch All in one Computer	Power: AC 120V/60Hz
Note: Mode:Transmit 802.11n40 at 5230MHz	

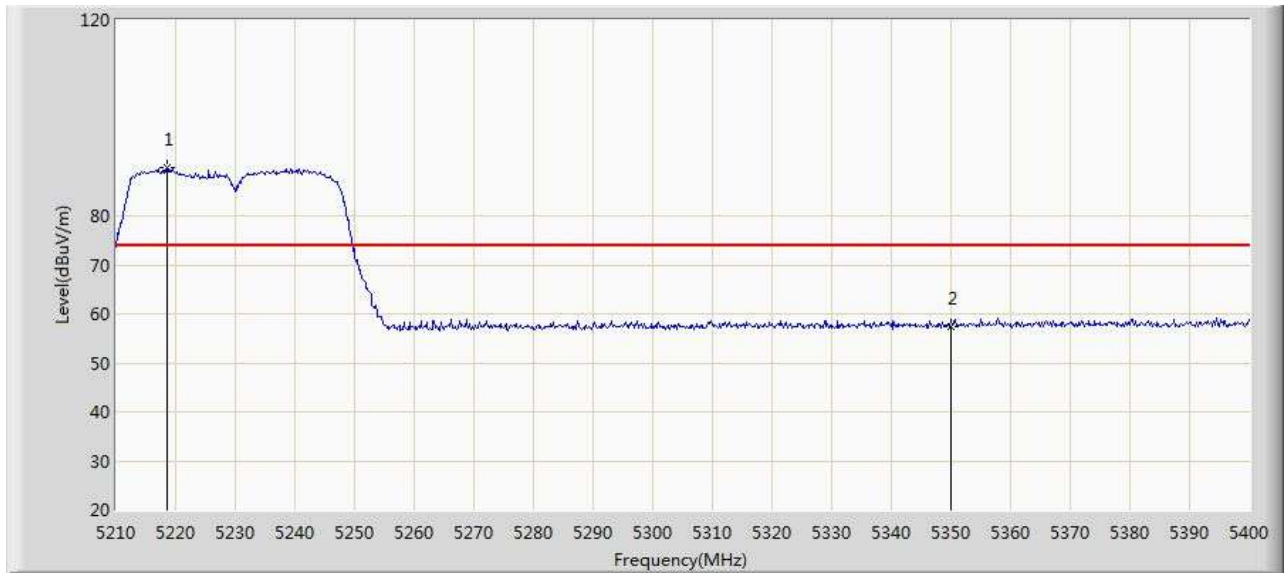

No	Mark	Frequency (MHz)	Measure Level (dBuV/m)	Reading Level (dBuV)	Over Limit (dB)	Limit (dBuV/m)	Factor (dB)	Type
1	*	5218.550	89.953	85.614	N/A	N/A	4.339	PK
2		5350.000	57.400	52.659	-16.600	74.000	4.741	PK

Note: Measure Level (dBuV/m) = Reading Level (dBuV) + Factor (dB)

Factor (dB) = Cable Loss (dB) + Antenna Factor (dB/m).



Site: AC102	Time: 2017/09/07 - 20:53
Limit: FCC_Part15.209_RE(3m)	Margin: 0
Probe: N/A	Polarity: Vertical
EUT: Touch All in one Computer	Power: AC 120V/60Hz
Note: Mode:Transmit 802.11n40 at 5230MHz	

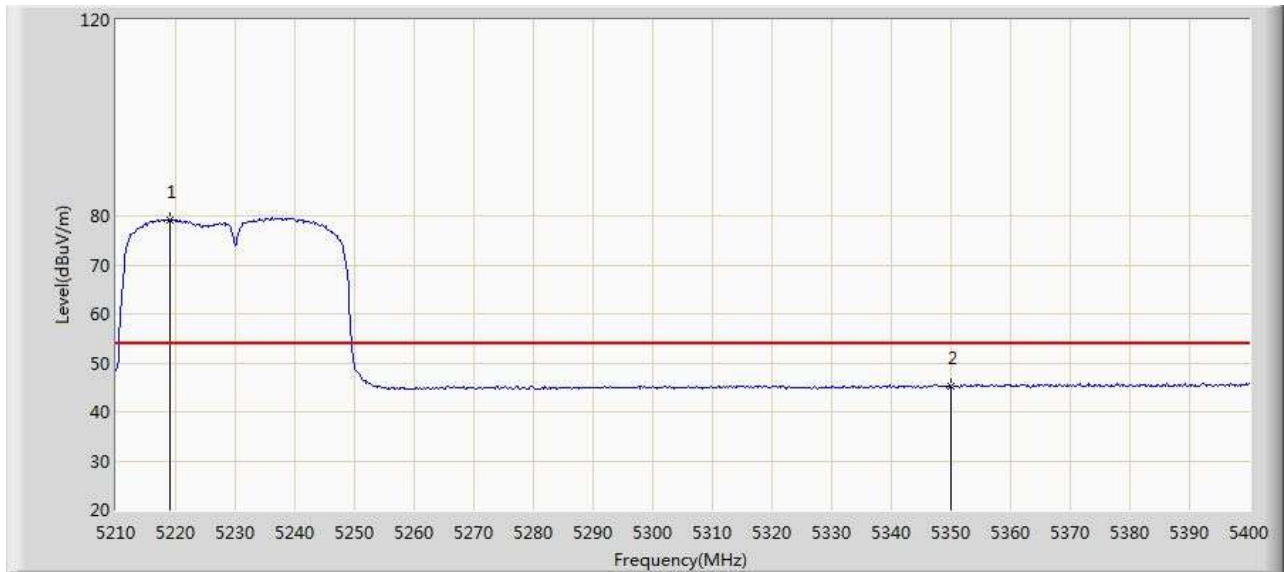

No	Mark	Frequency (MHz)	Measure Level (dBuV/m)	Reading Level (dBuV)	Over Limit (dB)	Limit (dBuV/m)	Factor (dB)	Type
1	*	5218.930	79.217	74.877	N/A	N/A	4.340	AV
2		5350.000	45.128	40.387	-8.872	54.000	4.741	AV

Note: Measure Level (dBuV/m) = Reading Level (dBuV) + Factor (dB)

Factor (dB) = Cable Loss (dB) + Antenna Factor (dB/m).



Site: AC102	Time: 2017/09/07 - 20:54
Limit: FCC_Part15.209_RE(3m)	Margin: 0
Probe: N/A	Polarity: Horizontal
EUT: Touch All in one Computer	Power: AC 120V/60Hz
Note: Mode:Transmit 802.11n40 at 5230MHz	

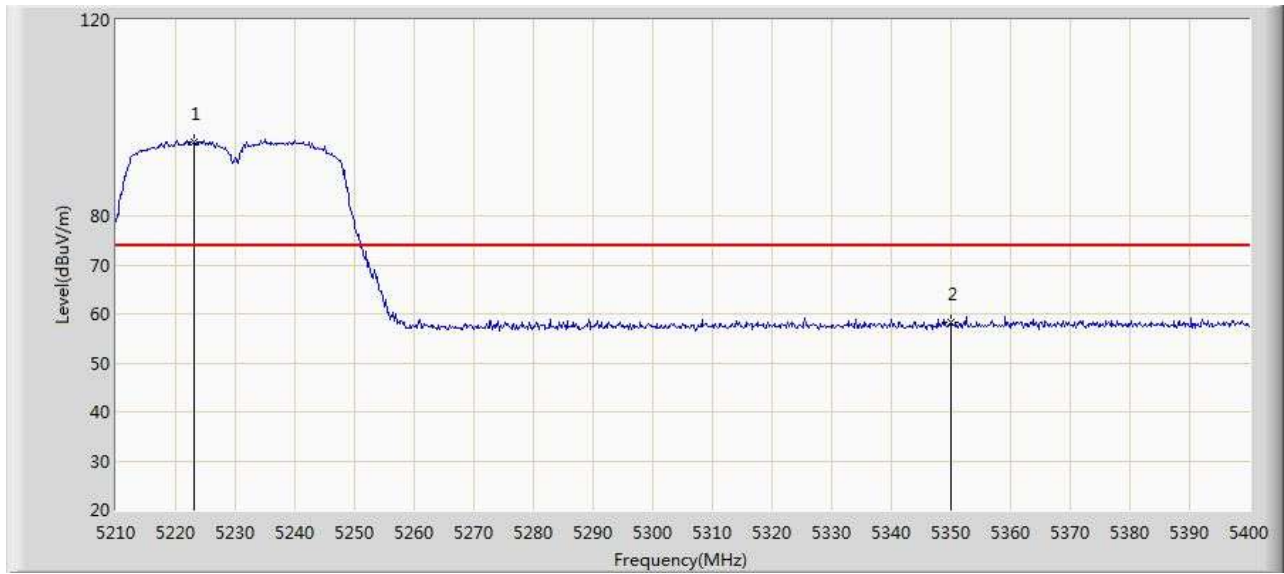

No	Mark	Frequency (MHz)	Measure Level (dBuV/m)	Reading Level (dBuV)	Over Limit (dB)	Limit (dBuV/m)	Factor (dB)	Type
1	*	5223.110	95.095	90.742	N/A	N/A	4.353	PK
2		5350.000	58.279	53.538	-15.721	74.000	4.741	PK

Note: Measure Level (dBuV/m) = Reading Level (dBuV) + Factor (dB)

Factor (dB) = Cable Loss (dB) + Antenna Factor (dB/m).



Site: AC102	Time: 2017/09/07 - 20:56
Limit: FCC_Part15.209_RE(3m)	Margin: 0
Probe: N/A	Polarity: Horizontal
EUT: Touch All in one Computer	Power: AC 120V/60Hz
Note: Mode:Transmit 802.11n40 at 5230MHz	

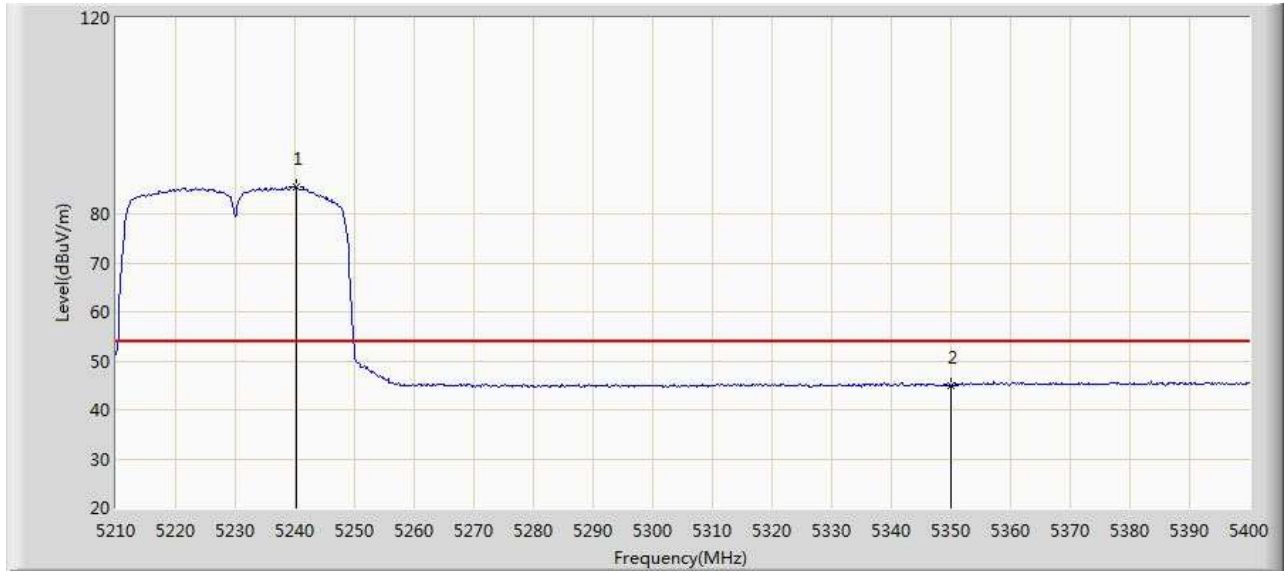

No	Mark	Frequency (MHz)	Measure Level (dBuV/m)	Reading Level (dBuV)	Over Limit (dB)	Limit (dBuV/m)	Factor (dB)	Type
1	*	5240.210	85.440	81.035	N/A	N/A	4.405	AV
2		5350.000	45.025	40.284	-8.975	54.000	4.741	AV

Note: Measure Level (dBuV/m) = Reading Level (dBuV) + Factor (dB)

Factor (dB) = Cable Loss (dB) + Antenna Factor (dB/m).



Site: AC102	Time: 2017/09/07 - 20:57
Limit: FCC_Part15.209_RE(3m)	Margin: 0
Probe: N/A	Polarity: Horizontal
EUT: Touch All in one Computer	Power: AC 120V/60Hz
Note: Mode:Transmit 802.11ac80 at 5210MHz	

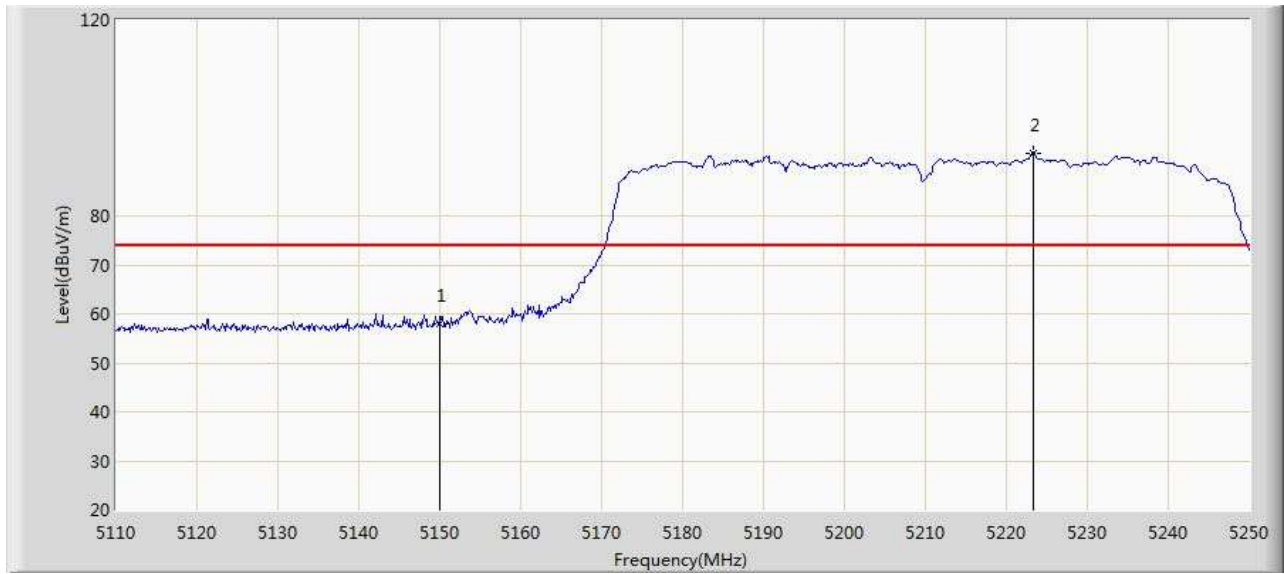

No	Mark	Frequency (MHz)	Measure Level (dBuV/m)	Reading Level (dBuV)	Over Limit (dB)	Limit (dBuV/m)	Factor (dB)	Type
1		5150.000	57.912	53.783	-16.088	74.000	4.129	PK
2	*	5223.260	92.857	88.504	N/A	N/A	4.353	PK

Note: Measure Level (dBuV/m) = Reading Level (dBuV) + Factor (dB)

Factor (dB) = Cable Loss (dB) + Antenna Factor (dB/m).



Site: AC102	Time: 2017/09/07 - 21:01
Limit: FCC_Part15.209_RE(3m)	Margin: 0
Probe: N/A	Polarity: Horizontal
EUT: Touch All in one Computer	Power: AC 120V/60Hz
Note: Mode:Transmit 802.11ac80 at 5210MHz	

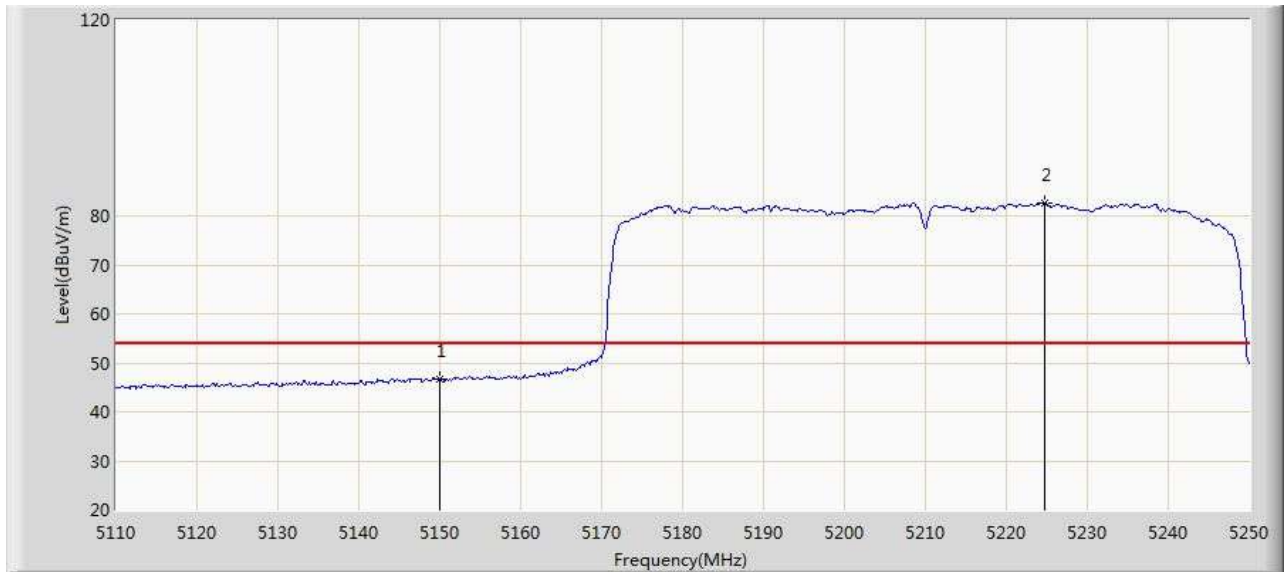

No	Mark	Frequency (MHz)	Measure Level (dBuV/m)	Reading Level (dBuV)	Over Limit (dB)	Limit (dBuV/m)	Factor (dB)	Type
1		5150.000	46.593	42.464	-7.407	54.000	4.129	AV
2	*	5224.800	82.607	78.249	N/A	N/A	4.358	AV

Note: Measure Level (dBuV/m) = Reading Level (dBuV) + Factor (dB)

Factor (dB) = Cable Loss (dB) + Antenna Factor (dB/m).



Site: AC102	Time: 2017/09/07 - 21:02
Limit: FCC_Part15.209_RE(3m)	Margin: 0
Probe: N/A	Polarity: Vertical
EUT: Touch All in one Computer	Power: AC 120V/60Hz
Note: Mode:Transmit 802.11ac80 at 5210MHz	

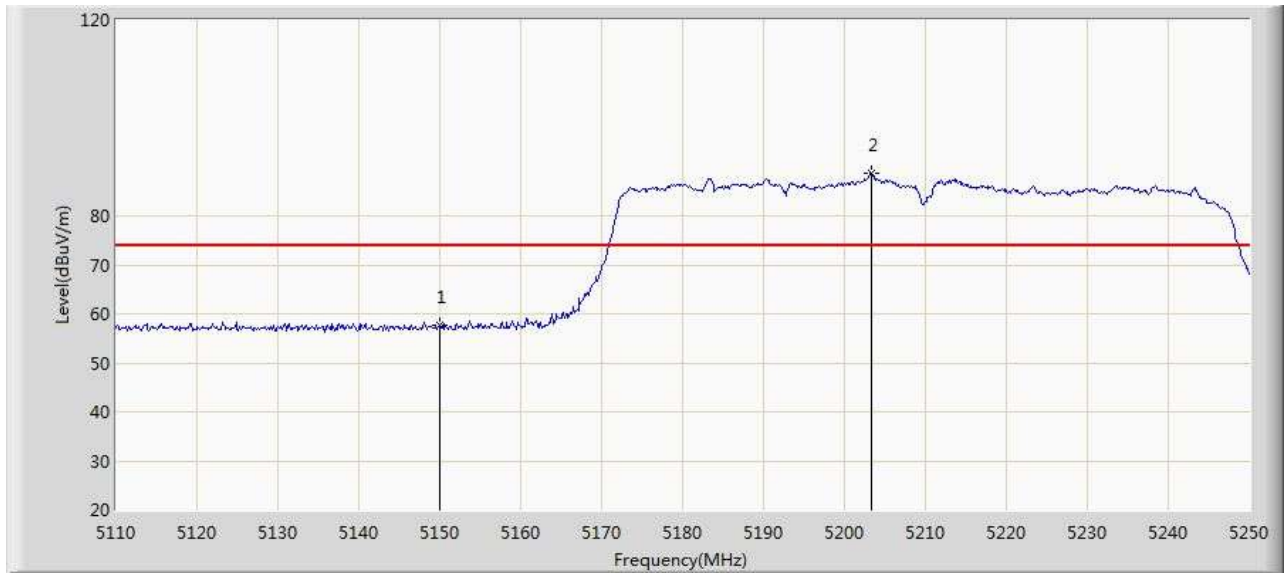

No	Mark	Frequency (MHz)	Measure Level (dBuV/m)	Reading Level (dBuV)	Over Limit (dB)	Limit (dBuV/m)	Factor (dB)	Type
1		5150.000	57.639	53.510	-16.361	74.000	4.129	PK
2	*	5203.380	88.802	84.510	N/A	N/A	4.292	PK

Note: Measure Level (dBuV/m) = Reading Level (dBuV) + Factor (dB)

Factor (dB) = Cable Loss (dB) + Antenna Factor (dB/m).



Site: AC102	Time: 2017/09/07 - 21:08
Limit: FCC_Part15.209_RE(3m)	Margin: 0
Probe: N/A	Polarity: Vertical
EUT: Touch All in one Computer	Power: AC 120V/60Hz
Note: Mode:Transmit 802.11ac80 at 5210MHz	

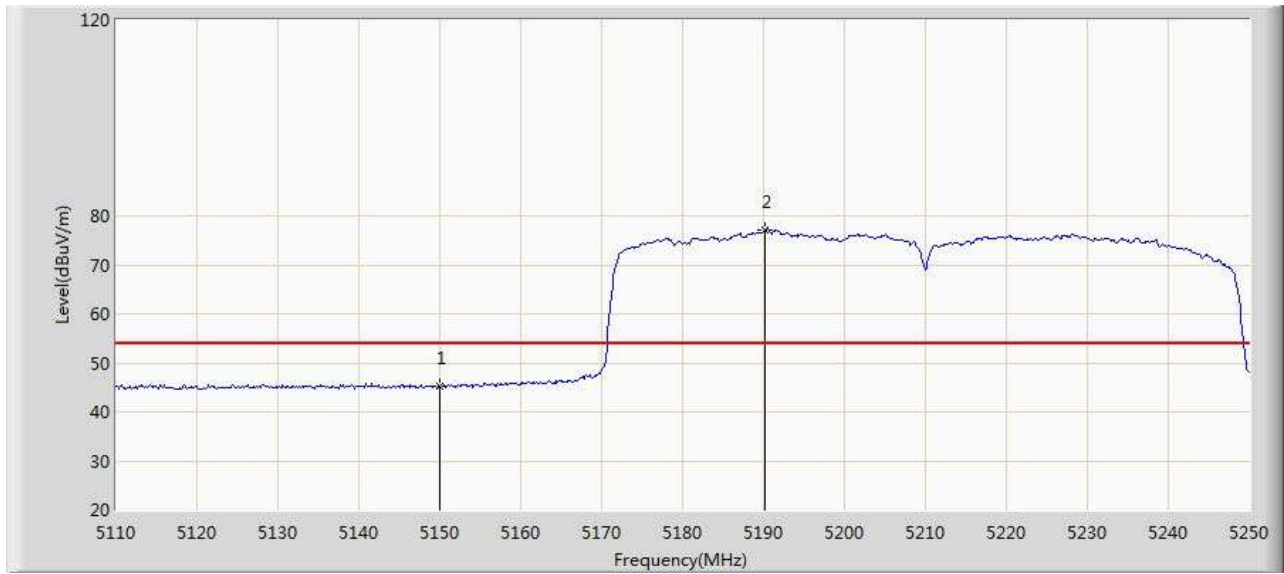

No	Mark	Frequency (MHz)	Measure Level (dBuV/m)	Reading Level (dBuV)	Over Limit (dB)	Limit (dBuV/m)	Factor (dB)	Type
1		5150.000	45.155	41.026	-8.845	54.000	4.129	AV
2	*	5190.220	77.012	72.760	N/A	N/A	4.252	AV

Note: Measure Level (dBuV/m) = Reading Level (dBuV) + Factor (dB)

Factor (dB) = Cable Loss (dB) + Antenna Factor (dB/m).



Site: AC102	Time: 2017/09/09 - 13:46
Limit: Bandedge-Band3	Margin: 0
Probe: N/A	Polarity: Horizontal
EUT: Touch All in one Computer	Power: AC 120V/60Hz
Note: Mode:Transmit 802.11a at 5745MHz	

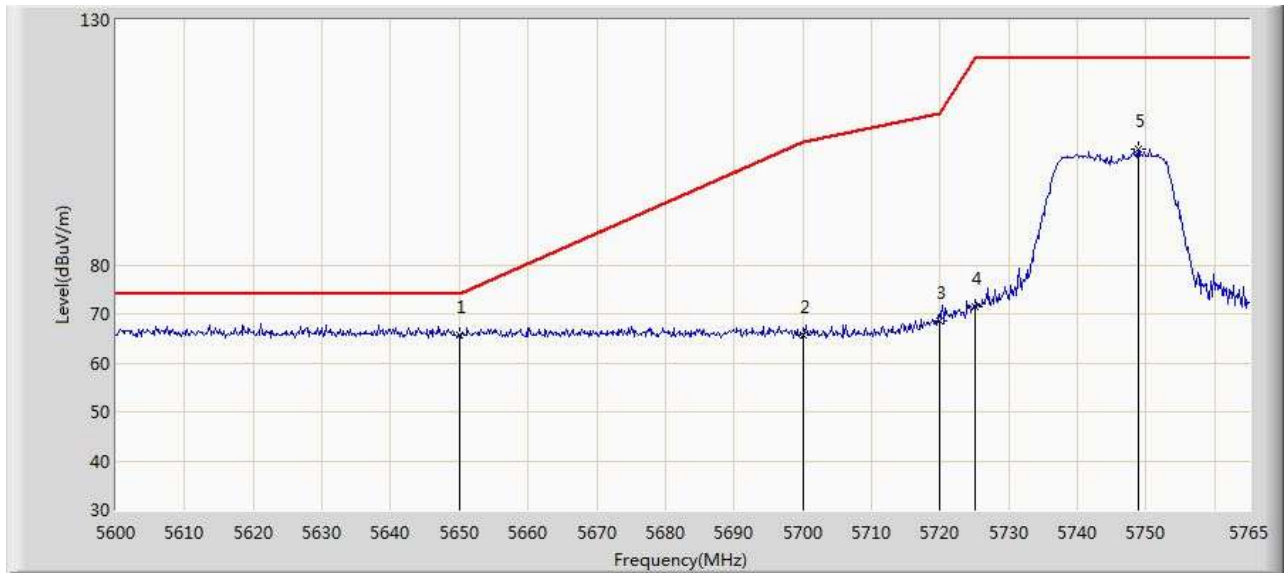

No	Mark	Frequency (MHz)	Measure Level (dBuV/m)	Reading Level (dBuV)	Over Limit (dB)	Limit (dBuV/m)	Factor (dB)	Type
1	*	5650.000	65.662	60.399	-8.338	74.000	5.263	PK
2		5700.000	65.694	60.410	-39.506	105.200	5.284	PK
3		5720.000	68.429	63.136	-42.371	110.800	5.293	PK
4		5725.000	71.424	66.129	-50.776	122.200	5.295	PK
5		5748.830	103.517	98.213	N/A	N/A	5.304	PK

Note: Measure Level (dBuV/m) = Reading Level (dBuV) + Factor (dB)

Factor (dB) = Cable Loss (dB) + Antenna Factor (dB/m).



Site: AC102	Time: 2017/09/09 - 14:02
Limit: Bandedge-Band3	Margin: 0
Probe: N/A	Polarity: Vertical
EUT: Touch All in one Computer	Power: AC 120V/60Hz
Note: Mode:Transmit 802.11a at 5745MHz	

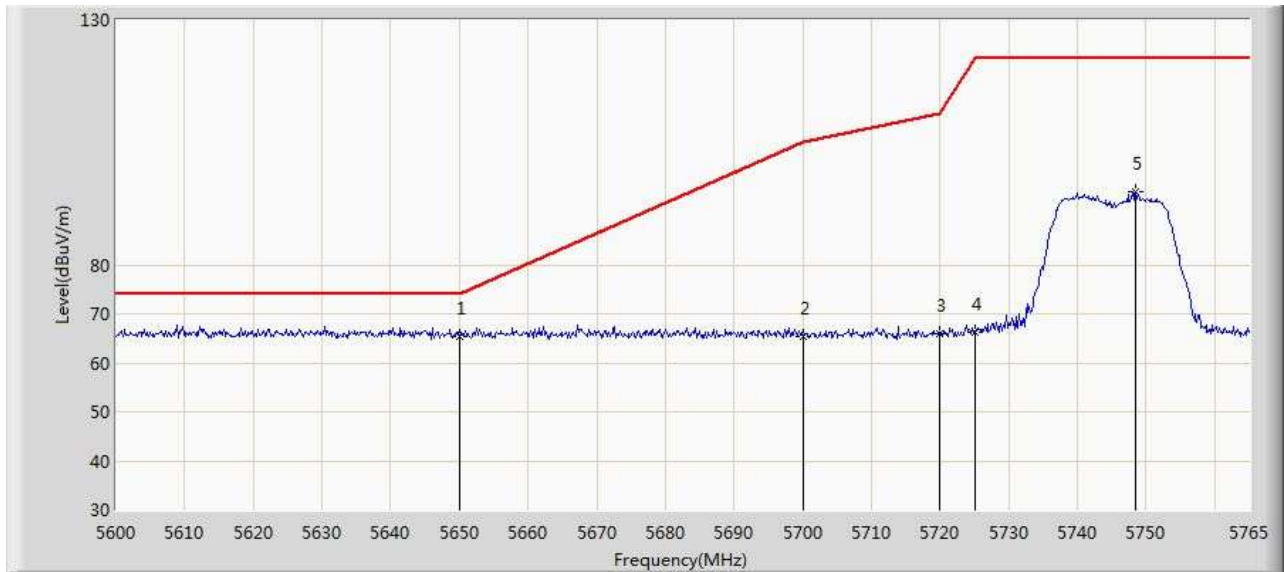

No	Mark	Frequency (MHz)	Measure Level (dBuV/m)	Reading Level (dBuV)	Over Limit (dB)	Limit (dBuV/m)	Factor (dB)	Type
1	*	5650.000	65.246	59.983	-8.754	74.000	5.263	PK
2		5700.000	65.416	60.132	-39.784	105.200	5.284	PK
3		5720.000	66.015	60.722	-44.785	110.800	5.293	PK
4		5725.000	66.112	60.817	-56.088	122.200	5.295	PK
5		5748.500	94.875	89.571	N/A	N/A	5.304	PK

Note: Measure Level (dBuV/m) = Reading Level (dBuV) + Factor (dB)

Factor (dB) = Cable Loss (dB) + Antenna Factor (dB/m).



Site: AC102	Time: 2017/09/09 - 14:06
Limit: Bandedge-Band3	Margin: 0
Probe: N/A	Polarity: Vertical
EUT: Touch All in one Computer	Power: AC 120V/60Hz
Note: Mode:Transmit 802.11a at 5825MHz	

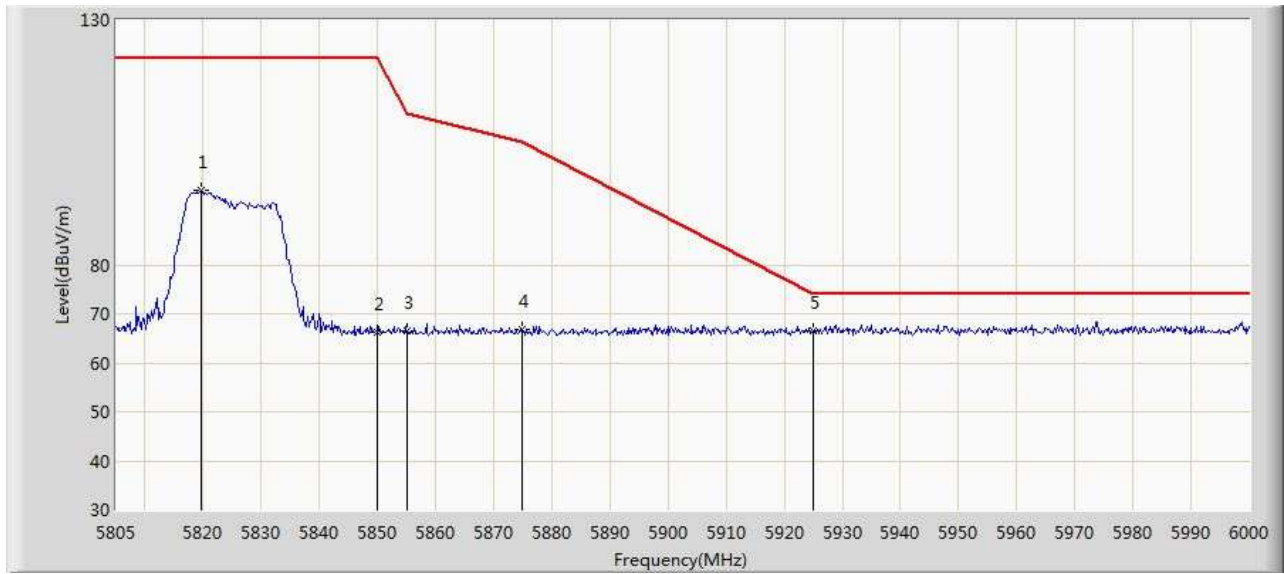

No	Mark	Frequency (MHz)	Measure Level (dBuV/m)	Reading Level (dBuV)	Over Limit (dB)	Limit (dBuV/m)	Factor (dB)	Type
1		5819.625	95.115	89.780	N/A	N/A	5.335	PK
2		5850.000	66.370	61.023	-55.830	122.200	5.347	PK
3		5855.000	66.664	61.315	-44.136	110.800	5.349	PK
4		5875.000	66.778	61.421	-38.422	105.200	5.357	PK
5	*	5925.000	66.489	61.110	-7.511	74.000	5.379	PK

Note: Measure Level (dBµV/m) = Reading Level (dBµV) + Factor (dB)

Factor (dB) = Cable Loss (dB) + Antenna Factor (dB/m).



Site: AC102	Time: 2017/09/09 - 14:07
Limit: Bandedge-Band3	Margin: 0
Probe: N/A	Polarity: Horizontal
EUT: Touch All in one Computer	Power: AC 120V/60Hz
Note: Mode: Transmit 802.11a at 5825MHz	

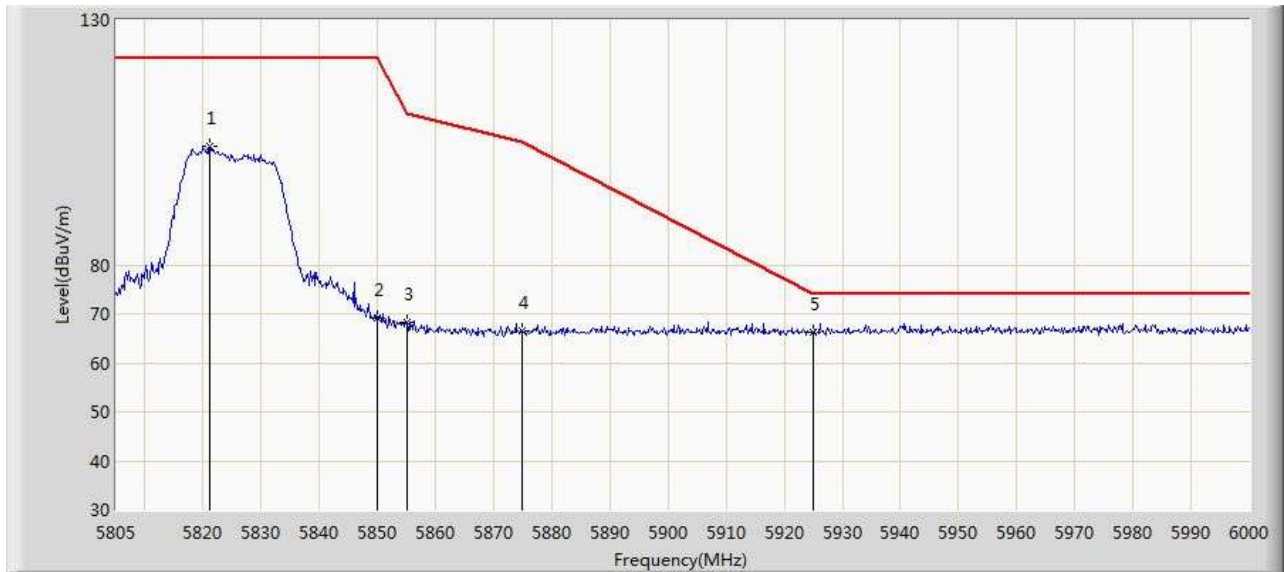

No	Mark	Frequency (MHz)	Measure Level (dBuV/m)	Reading Level (dBuV)	Over Limit (dB)	Limit (dBuV/m)	Factor (dB)	Type
1		5821.185	104.316	98.981	N/A	N/A	5.335	PK
2		5850.000	69.190	63.843	-53.010	122.200	5.347	PK
3		5855.000	68.174	62.825	-42.626	110.800	5.349	PK
4		5875.000	66.519	61.162	-38.681	105.200	5.357	PK
5	*	5925.000	66.289	60.910	-7.711	74.000	5.379	PK

Note: Measure Level (dBuV/m) = Reading Level (dBuV) + Factor (dB)

Factor (dB) = Cable Loss (dB) + Antenna Factor (dB/m).



Site: AC102	Time: 2017/09/09 - 14:09
Limit: Bandedge-Band3	Margin: 0
Probe: N/A	Polarity: Horizontal
EUT: Touch All in one Computer	Power: AC 120V/60Hz
Note: Mode:Transmit 802.11n(20MHz) at 5745MHz	

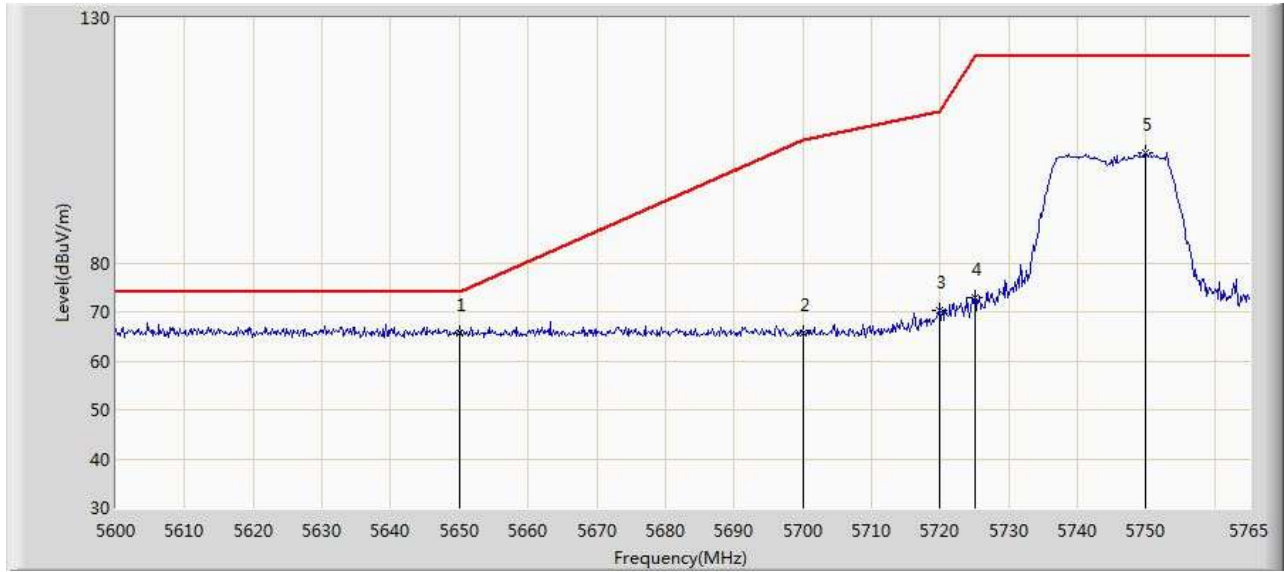

No	Mark	Frequency (MHz)	Measure Level (dBuV/m)	Reading Level (dBuV)	Over Limit (dB)	Limit (dBuV/m)	Factor (dB)	Type
1	*	5650.000	65.690	60.427	-8.310	74.000	5.263	PK
2		5700.000	65.671	60.387	-39.529	105.200	5.284	PK
3		5720.000	70.162	64.869	-40.638	110.800	5.293	PK
4		5725.000	72.984	67.689	-49.216	122.200	5.295	PK
5		5749.820	102.327	97.022	N/A	N/A	5.305	PK

Note: Measure Level (dBuV/m) = Reading Level (dBuV) + Factor (dB)

Factor (dB) = Cable Loss (dB) + Antenna Factor (dB/m).



Site: AC102	Time: 2017/09/09 - 14:10
Limit: Bandedge-Band3	Margin: 0
Probe: N/A	Polarity: Vertical
EUT: Touch All in one Computer	Power: AC 120V/60Hz
Note: Mode:Transmit 802.11n(20MHz) at 5745MHz	

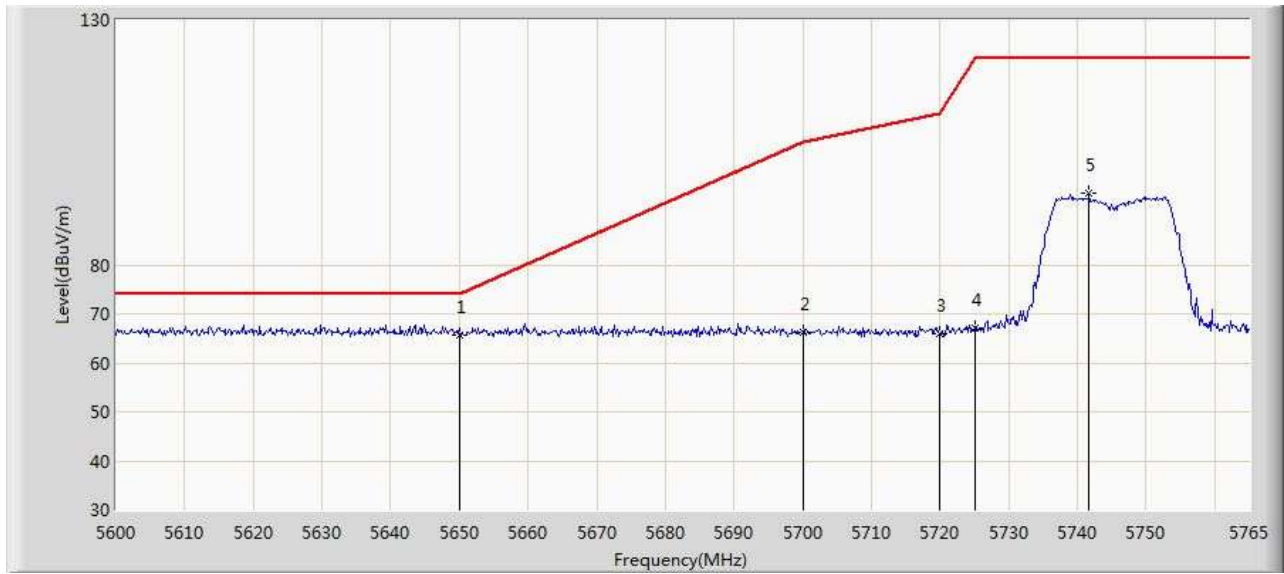

No	Mark	Frequency (MHz)	Measure Level (dBuV/m)	Reading Level (dBuV)	Over Limit (dB)	Limit (dBuV/m)	Factor (dB)	Type
1	*	5650.000	65.654	60.391	-8.346	74.000	5.263	PK
2		5700.000	66.180	60.896	-39.020	105.200	5.284	PK
3		5720.000	65.832	60.539	-44.968	110.800	5.293	PK
4		5725.000	66.974	61.679	-55.226	122.200	5.295	PK
5		5741.735	94.619	89.318	N/A	N/A	5.301	PK

Note: Measure Level (dBuV/m) = Reading Level (dBuV) + Factor (dB)

Factor (dB) = Cable Loss (dB) + Antenna Factor (dB/m).



Site: AC102	Time: 2017/09/09 - 14:11
Limit: Bandedge-Band3	Margin: 0
Probe: N/A	Polarity: Vertical
EUT: Touch All in one Computer	Power: AC 120V/60Hz
Note: Mode:Transmit 802.11n(20MHz) at 5825MHz	

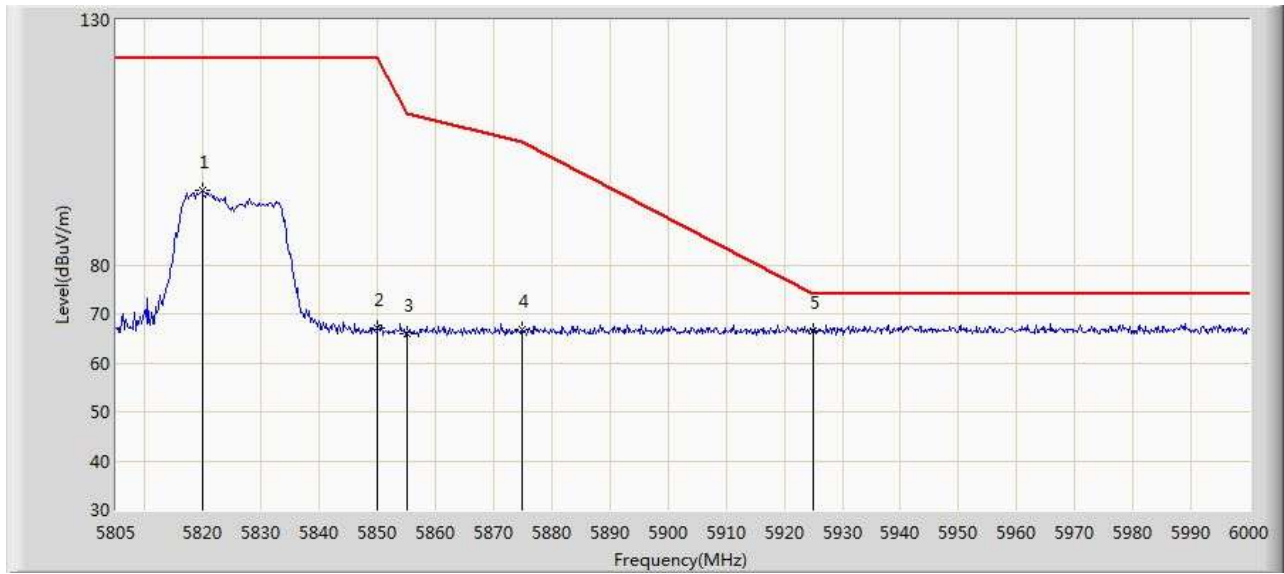

No	Mark	Frequency (MHz)	Measure Level (dBuV/m)	Reading Level (dBuV)	Over Limit (dB)	Limit (dBuV/m)	Factor (dB)	Type
1		5819.820	95.238	89.903	N/A	N/A	5.335	PK
2		5850.000	66.988	61.641	-55.212	122.200	5.347	PK
3		5855.000	65.857	60.508	-44.943	110.800	5.349	PK
4		5875.000	66.770	61.413	-38.430	105.200	5.357	PK
5	*	5925.000	66.639	61.260	-7.361	74.000	5.379	PK

Note: Measure Level (dBuV/m) = Reading Level (dBuV) + Factor (dB)

Factor (dB) = Cable Loss (dB) + Antenna Factor (dB/m).



Site: AC102	Time: 2017/09/09 - 14:13
Limit: Bandedge-Band3	Margin: 0
Probe: N/A	Polarity: Horizontal
EUT: Touch All in one Computer	Power: AC 120V/60Hz
Note: Mode:Transmit 802.11n(20MHz) at 5825MHz	

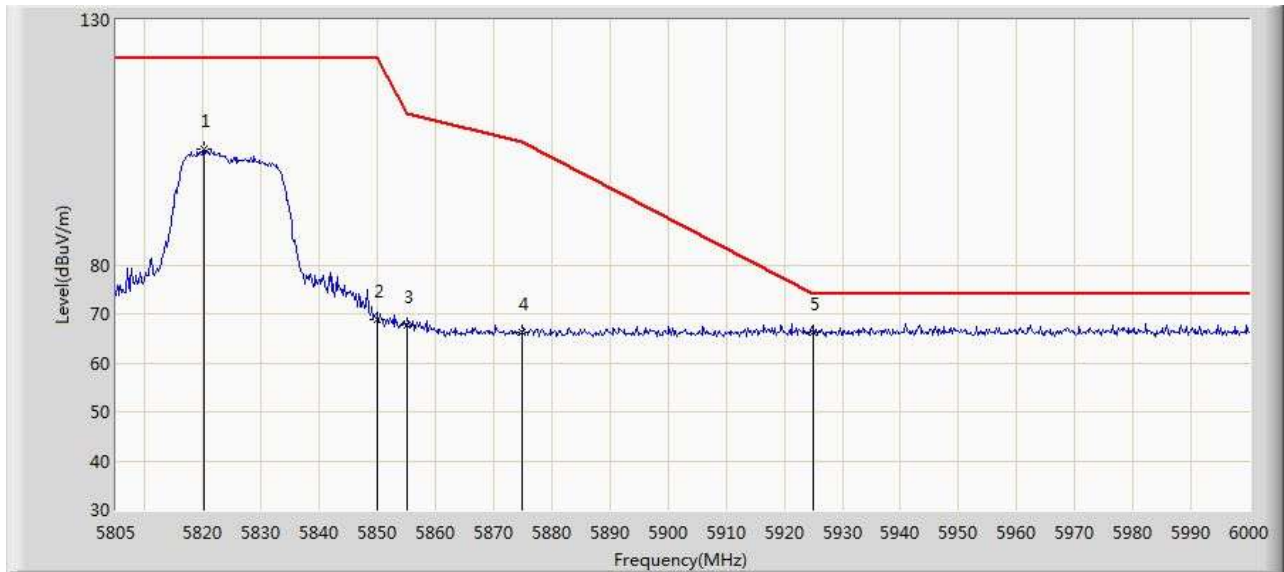

No	Mark	Frequency (MHz)	Measure Level (dBuV/m)	Reading Level (dBuV)	Over Limit (dB)	Limit (dBuV/m)	Factor (dB)	Type
1		5820.210	103.602	98.267	N/A	N/A	5.335	PK
2		5850.000	68.873	63.526	-53.327	122.200	5.347	PK
3		5855.000	67.614	62.265	-43.186	110.800	5.349	PK
4		5875.000	66.292	60.935	-38.908	105.200	5.357	PK
5	*	5925.000	66.332	60.953	-7.668	74.000	5.379	PK

Note: Measure Level (dBuV/m) = Reading Level (dBuV) + Factor (dB)

Factor (dB) = Cable Loss (dB) + Antenna Factor (dB/m).



Site: AC102	Time: 2017/09/09 - 14:14
Limit: Bandedge-Band3	Margin: 0
Probe: N/A	Polarity: Horizontal
EUT: Touch All in one Computer	Power: AC 120V/60Hz
Note: Mode: Transmit 802.11n(40MHz) at 5755MHz	

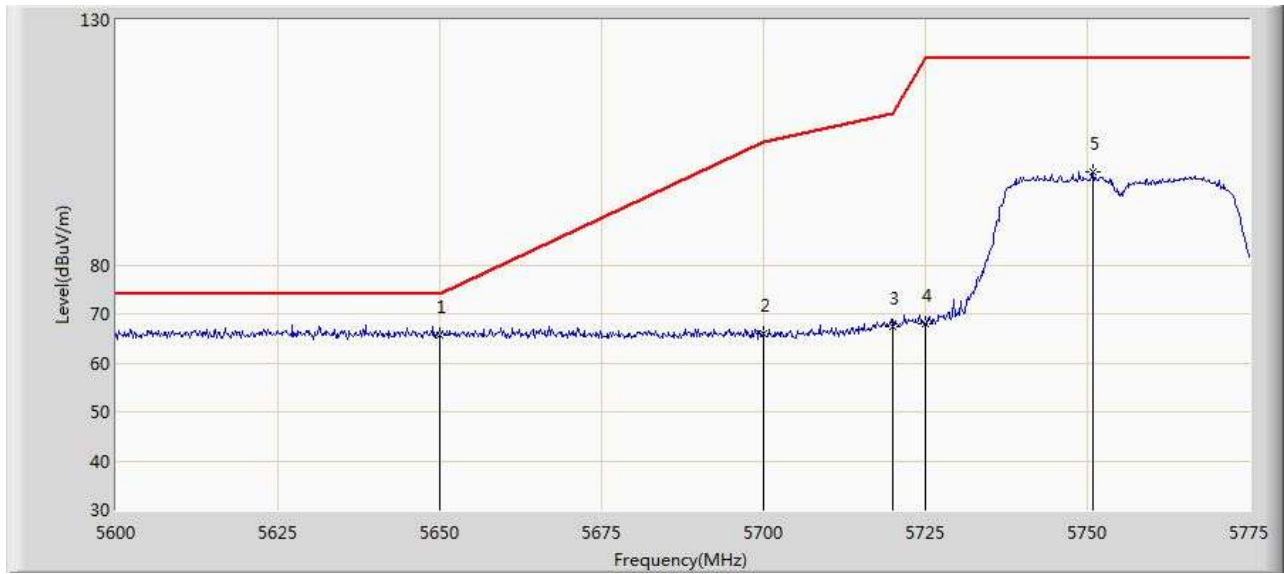

No	Mark	Frequency (MHz)	Measure Level (dBuV/m)	Reading Level (dBuV)	Over Limit (dB)	Limit (dBuV/m)	Factor (dB)	Type
1	*	5650.000	65.642	60.379	-8.358	74.000	5.263	PK
2		5700.000	66.040	60.756	-39.160	105.200	5.284	PK
3		5720.000	67.394	62.101	-43.406	110.800	5.293	PK
4		5725.000	67.830	62.535	-54.370	122.200	5.295	PK
5		5750.850	98.850	93.545	N/A	N/A	5.305	PK

Note: Measure Level (dBuV/m) = Reading Level (dBuV) + Factor (dB)

Factor (dB) = Cable Loss (dB) + Antenna Factor (dB/m).



Site: AC102	Time: 2017/09/09 - 14:16
Limit: Bandedge-Band3	Margin: 0
Probe: N/A	Polarity: Vertical
EUT: Touch All in one Computer	Power: AC 120V/60Hz
Note: Mode:Transmit 802.11n(40MHz) at 5755MHz	

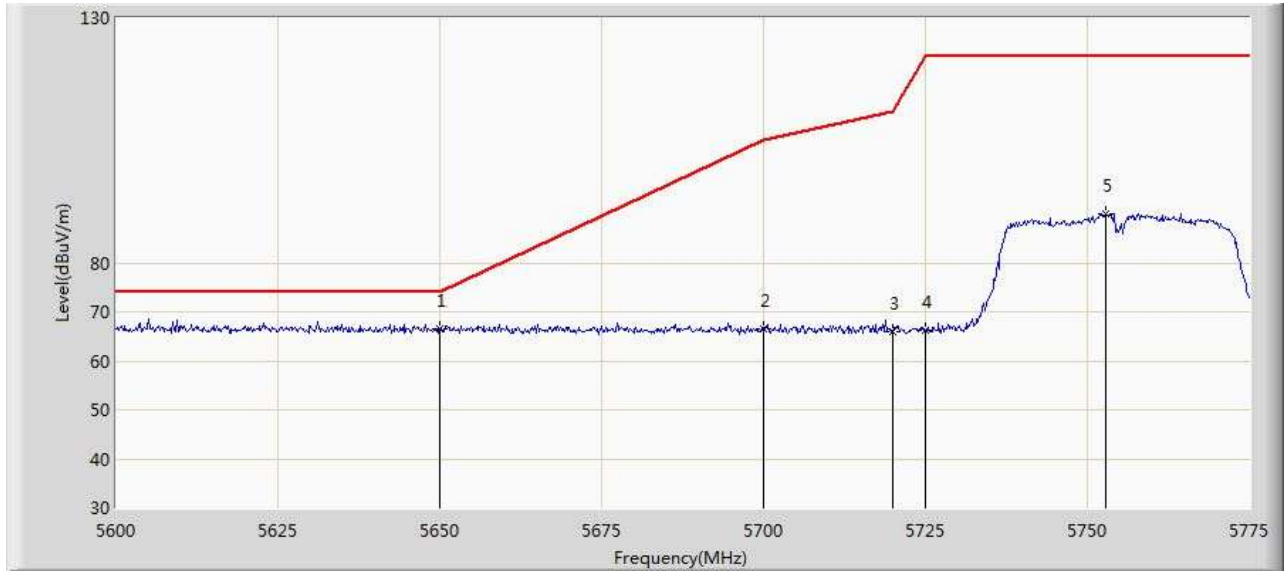

No	Mark	Frequency (MHz)	Measure Level (dBuV/m)	Reading Level (dBuV)	Over Limit (dB)	Limit (dBuV/m)	Factor (dB)	Type
1	*	5650.000	66.567	61.304	-7.433	74.000	5.263	PK
2		5700.000	66.441	61.157	-38.759	105.200	5.284	PK
3		5720.000	66.030	60.737	-44.770	110.800	5.293	PK
4		5725.000	66.141	60.846	-56.059	122.200	5.295	PK
5		5752.775	89.959	84.653	N/A	N/A	5.306	PK

Note: Measure Level (dBuV/m) = Reading Level (dBuV) + Factor (dB)

Factor (dB) = Cable Loss (dB) + Antenna Factor (dB/m).



Site: AC102	Time: 2017/09/09 - 14:17
Limit: Bandedge-Band3	Margin: 0
Probe: N/A	Polarity: Vertical
EUT: Touch All in one Computer	Power: AC 120V/60Hz
Note: Mode:Transmit 802.11n(40MHz) at 5795MHz	

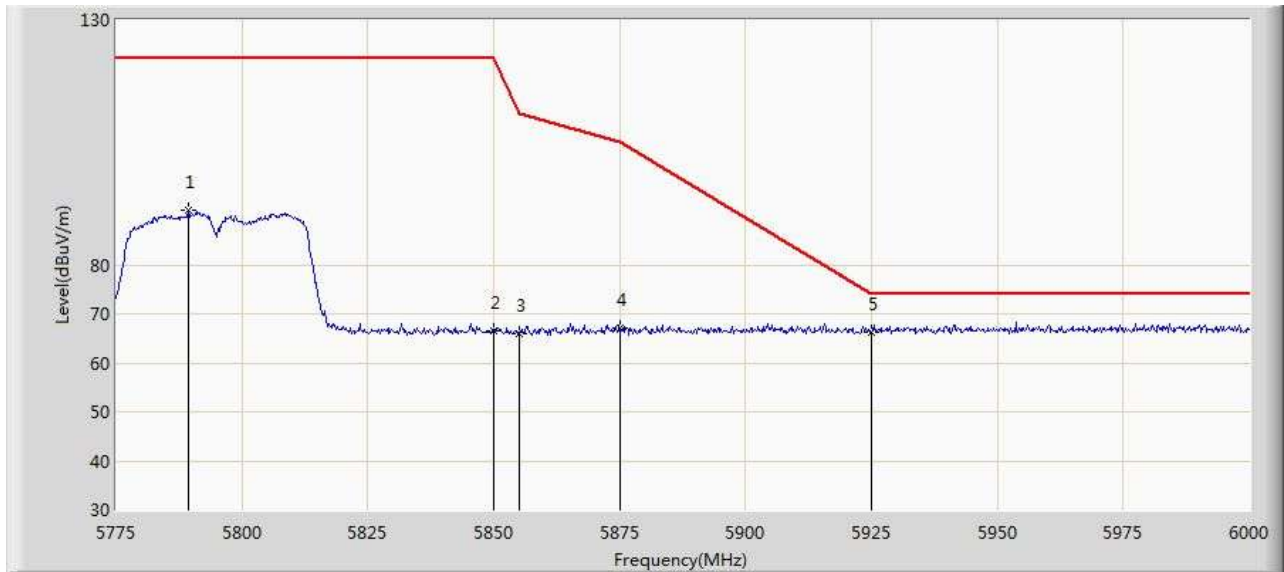

No	Mark	Frequency (MHz)	Measure Level (dBuV/m)	Reading Level (dBuV)	Over Limit (dB)	Limit (dBuV/m)	Factor (dB)	Type
1		5789.400	91.301	85.980	N/A	N/A	5.321	PK
2		5850.000	66.626	61.279	-55.574	122.200	5.347	PK
3		5855.000	65.945	60.596	-44.855	110.800	5.349	PK
4		5875.000	67.203	61.846	-37.997	105.200	5.357	PK
5	*	5925.000	66.212	60.833	-7.788	74.000	5.379	PK

Note: Measure Level (dBuV/m) = Reading Level (dBuV) + Factor (dB)

Factor (dB) = Cable Loss (dB) + Antenna Factor (dB/m).



Site: AC102	Time: 2017/09/09 - 14:19
Limit: Bandedge-Band3	Margin: 0
Probe: N/A	Polarity: Horizontal
EUT: Touch All in one Computer	Power: AC 120V/60Hz
Note: Mode:Transmit 802.11n(40MHz) at 5795MHz	

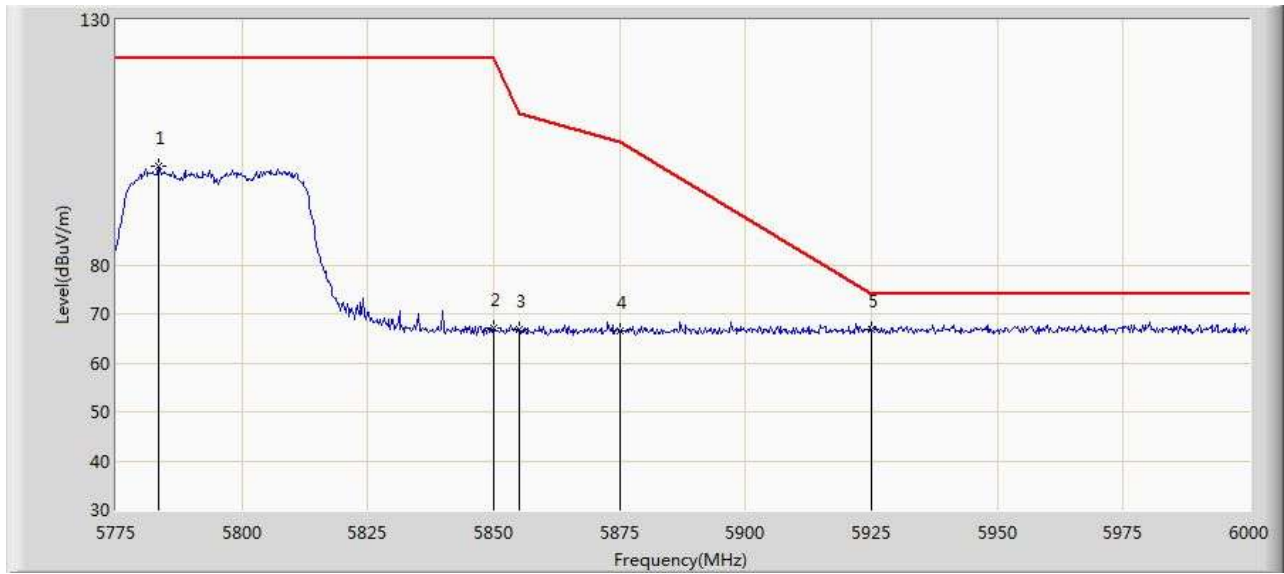

No	Mark	Frequency (MHz)	Measure Level (dBuV/m)	Reading Level (dBuV)	Over Limit (dB)	Limit (dBuV/m)	Factor (dB)	Type
1		5783.325	100.028	94.709	N/A	N/A	5.319	PK
2		5850.000	66.960	61.613	-55.240	122.200	5.347	PK
3		5855.000	66.811	61.462	-43.989	110.800	5.349	PK
4		5875.000	66.545	61.188	-38.655	105.200	5.357	PK
5	*	5925.000	66.670	61.291	-7.330	74.000	5.379	PK

Note: Measure Level (dBuV/m) = Reading Level (dBuV) + Factor (dB)

Factor (dB) = Cable Loss (dB) + Antenna Factor (dB/m).



Site: AC102	Time: 2017/09/09 - 14:21
Limit: Bandedge-Band3	Margin: 0
Probe: N/A	Polarity: Horizontal
EUT: Touch All in one Computer	Power: AC 120V/60Hz
Note: Mode:Transmit 802.11ac(80MHz) at 5775MHz	

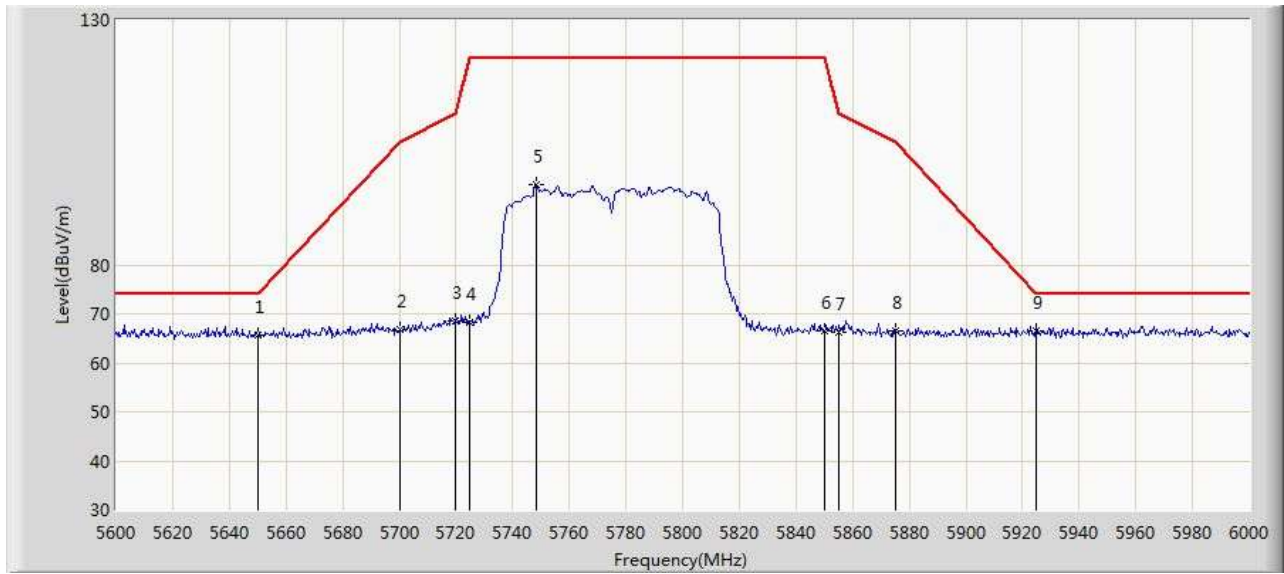

No	Mark	Frequency (MHz)	Measure Level (dBuV/m)	Reading Level (dBuV)	Over Limit (dB)	Limit (dBuV/m)	Factor (dB)	Type
1		5650.000	65.683	60.420	-8.317	74.000	5.263	PK
2		5700.000	66.711	61.427	-38.489	105.200	5.284	PK
3		5720.000	68.442	63.149	-42.358	110.800	5.293	PK
4		5725.000	68.352	63.057	-53.848	122.200	5.295	PK
5		5748.400	96.513	91.209	N/A	N/A	5.304	PK
6		5850.000	66.651	61.304	-55.549	122.200	5.347	PK
7		5855.000	66.337	60.988	-44.463	110.800	5.349	PK
8		5875.000	66.621	61.264	-38.579	105.200	5.357	PK
9	*	5925.000	66.631	61.252	-7.369	74.000	5.379	PK

Note: Measure Level (dBuV/m) = Reading Level (dBuV) + Factor (dB)

Factor (dB) = Cable Loss (dB) + Antenna Factor (dB/m).



Site: AC102	Time: 2017/09/09 - 14:22
Limit: Bandedge-Band3	Margin: 0
Probe: N/A	Polarity: Vertical
EUT: Touch All in one Computer	Power: AC 120V/60Hz
Note: Mode:Transmit 802.11ac(80MHz) at 5775MHz	

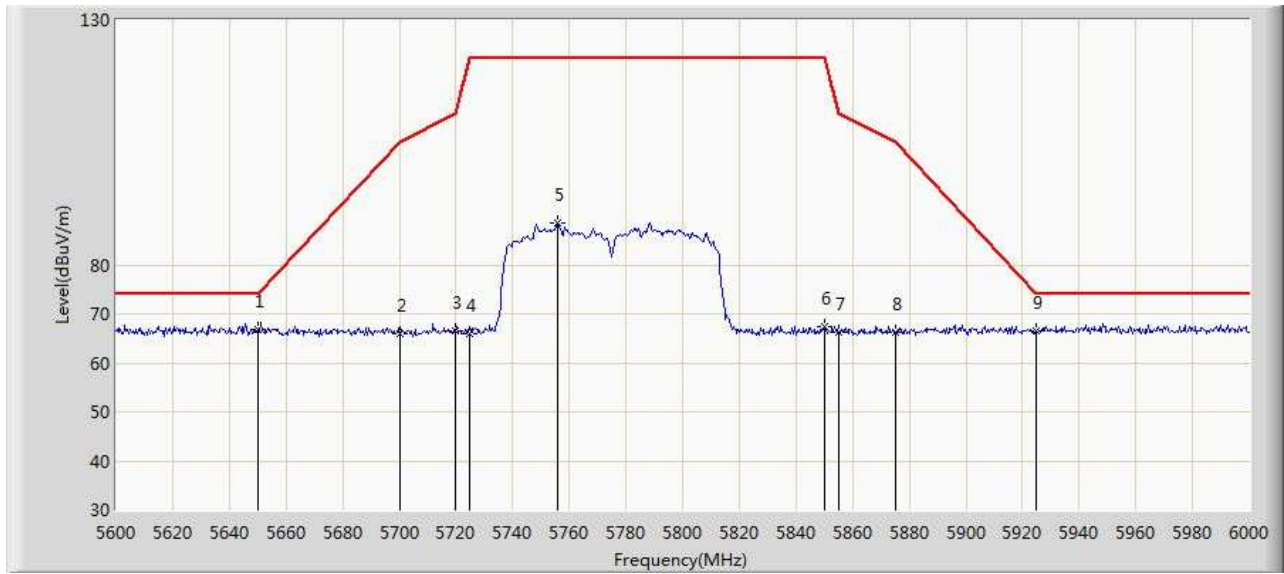

No	Mark	Frequency (MHz)	Measure Level (dBuV/m)	Reading Level (dBuV)	Over Limit (dB)	Limit (dBuV/m)	Factor (dB)	Type
1	*	5650.000	66.794	61.531	-7.206	74.000	5.263	PK
2		5700.000	66.067	60.783	-39.133	105.200	5.284	PK
3		5720.000	66.635	61.342	-44.165	110.800	5.293	PK
4		5725.000	65.998	60.703	-56.202	122.200	5.295	PK
5		5756.000	88.514	83.207	N/A	N/A	5.307	PK
6		5850.000	67.337	61.990	-54.863	122.200	5.347	PK
7		5855.000	66.364	61.015	-44.436	110.800	5.349	PK
8		5875.000	66.318	60.961	-38.882	105.200	5.357	PK
9		5925.000	66.495	61.116	-7.505	74.000	5.379	PK

Note: Measure Level (dBuV/m) = Reading Level (dBuV) + Factor (dB)

Factor (dB) = Cable Loss (dB) + Antenna Factor (dB/m).



10. Frequency Stability

10.1 Test Limit

According to FCC Part 15.407 – Section (g), manufactures of U-NII devices are responsible for ensuring frequency stability such that an emission is maintained within the band of operation under all conditions of normal operation as specified in the user’s manual.

10.2 Test Standard

ANSI C63.10-2013 – Section 6.8

10.3 Test Procedures

Frequency Stability Under Temperature Variations:

The equipment under test was connected to an external AC or DC power supply and input rated voltage. RF output was connected to a frequency counter or spectrum analyzer via feed through attenuators. The EUT was placed inside the temperature chamber. Set the spectrum analyzer RBW low enough to obtain the desired frequency resolution and measure EUT 20°C operating frequency as reference frequency. Turn EUT off and set the chamber temperature to highest. After the temperature stabilized for approximately 30 minutes recorded the frequency. Repeat step measure with 10°C decreased per stage until the lowest temperature reached.

Frequency Stability Under Voltage Variations:

Set chamber temperature to 20°C. Use a variable AC power supply / DC power source to power the EUT and set the voltage to rated voltage. Set the spectrum analyzer RBW low enough to obtain the desired frequency resolution and recorded the frequency.

Reduce the input voltage to specify extreme voltage variation ($\pm 15\%$) and endpoint, record the maximum frequency change.



10.4 Test Setup

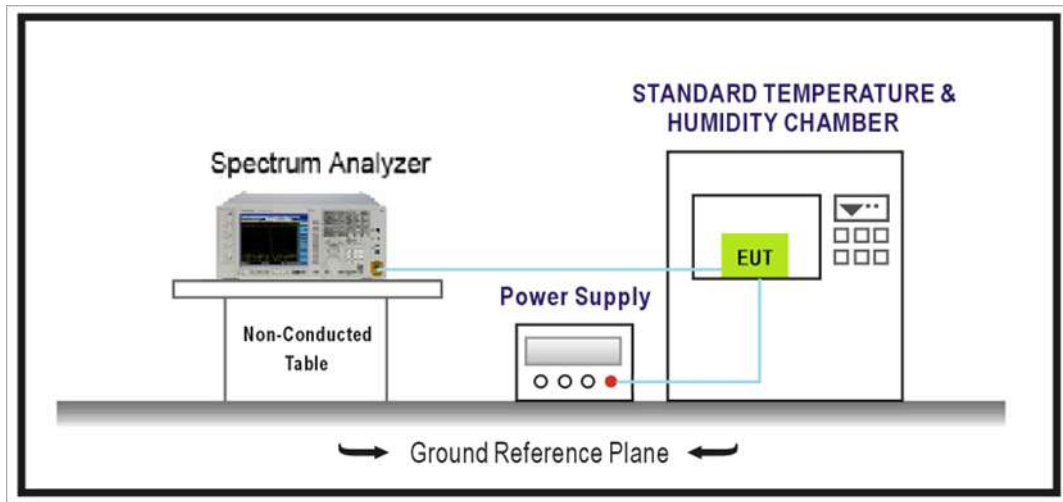

**10.5 Test Result and Data**

Product	Touch All in one Computer
Test Item	Frequency Stability
Test Mode	Carrier Transmit

Operating Frequency	Temp (°C)	Voltage (AC)	Frequency Tolerance (ppm)				
			0 minutes		2 minutes		
			Operation Frequency(MHz)	Measure Level(ppm)	Operation Frequency(MHz)	Measure Level(ppm)	
36	0	102	5180.0100	1.93	5180.0107	2.07	
		120	5180.0157	3.03	5180.0185	3.57	
		138	5180.0142	2.74	5180.0100	1.93	
	10	102	5180.0101	1.95	5180.0139	2.68	
		120	5180.0149	2.88	5180.0145	2.80	
		138	5180.0191	3.69	5180.0160	3.09	
	20	102	5180.0120	2.32	5180.0117	2.26	
		120	5180.0127	2.45	5180.0166	3.20	
		138	5180.0183	3.53	5180.0152	2.93	
	30	102	5180.0158	3.05	5180.0151	2.92	
		120	5180.0153	2.95	5180.0134	2.59	
		138	5180.0138	2.66	5180.0164	3.17	
	40	102	5180.0139	2.68	5180.0104	2.01	
		120	5180.0121	2.34	5180.0150	2.90	
		138	5180.0117	2.26	5180.0196	3.78	
	44	0	102	5220.0200	3.83	5220.0147	2.82
			120	5220.0105	2.01	5220.0186	3.56
			138	5220.0179	3.43	5220.0172	3.30
10		102	5220.0156	2.99	5220.0170	3.26	
		120	5220.0194	3.72	5220.0117	2.24	
		138	5220.0187	3.58	5220.0113	2.16	
20		102	5220.0170	3.26	5220.0157	3.01	
		120	5220.0174	3.33	5220.0173	3.31	
		138	5220.0189	3.62	5220.0160	3.07	
30		102	5220.0136	2.61	5220.0169	3.24	



		120	5220.0127	2.43	5220.0172	3.30	
		138	5220.0145	2.78	5220.0172	3.30	
	40	102	5220.0194	3.72	5220.0130	2.49	
		120	5220.0110	2.11	5220.0183	3.51	
		138	5220.0146	2.80	5220.0180	3.45	
48	0	102	5240.0150	2.86	5240.0146	2.79	
		120	5240.0135	2.58	5240.0106	2.02	
		138	5240.0140	2.67	5240.0106	2.02	
	10	102	5240.0105	2.00	5240.0161	3.07	
		120	5240.0100	1.91	5240.0104	1.98	
		138	5240.0181	3.45	5240.0116	2.21	
	20	102	5240.0193	3.68	5240.0125	2.39	
		120	5240.0164	3.13	5240.0129	2.46	
		138	5240.0188	3.59	5240.0129	2.46	
	30	102	5240.0200	3.82	5240.0111	2.12	
		120	5240.0111	2.12	5240.0135	2.58	
		138	5240.0191	3.65	5240.0130	2.48	
	40	102	5240.0154	2.94	5240.0142	2.71	
		120	5240.0125	2.39	5240.0107	2.04	
		138	5240.0123	2.35	5240.0149	2.84	
	149	0	102	5745.0194	3.38	5745.0165	2.87
			120	5745.0103	1.79	5745.0104	1.81
			138	5745.0128	2.23	5745.0185	3.22
		10	102	5745.0121	2.11	5745.0103	1.79
			120	5745.0184	3.20	5745.0158	2.75
			138	5745.0118	2.05	5745.0102	1.78
20		102	5745.0122	2.12	5745.0169	2.94	
		120	5745.0177	3.08	5745.0173	3.01	
		138	5745.0161	2.80	5745.0124	2.16	
30		102	5745.0191	3.32	5745.0189	3.29	
		120	5745.0174	3.03	5745.0156	2.72	
		138	5745.0163	2.84	5745.0142	2.47	
40		102	5745.0172	2.99	5745.0179	3.12	
		120	5745.0105	1.83	5745.0197	3.43	
		138	5745.0132	2.30	5745.0165	2.87	



157	0	102	5785.0137	2.37	5785.0175	3.03
		120	5785.0161	2.78	5785.0166	2.87
		138	5785.0193	3.34	5785.0169	2.92
	10	102	5785.0152	2.63	5785.0133	2.30
		120	5785.0170	2.94	5785.0191	3.30
		138	5785.0138	2.39	5785.0145	2.51
	20	102	5785.0200	3.46	5785.0160	2.77
		120	5785.0135	2.33	5785.0110	1.90
		138	5785.0121	2.09	5785.0179	3.09
	30	102	5785.0119	2.06	5785.0106	1.83
		120	5785.0125	2.16	5785.0177	3.06
		138	5785.0184	3.18	5785.0113	1.95
40	102	5785.0154	2.66	5785.0103	1.78	
	120	5785.0193	3.34	5785.0114	1.97	
	138	5785.0197	3.41	5785.0108	1.87	
165	0	102	5825.0164	2.82	5825.0150	2.58
		120	5825.0145	2.49	5825.0144	2.47
		138	5825.0105	1.80	5825.0192	3.30
	10	102	5825.0109	1.87	5825.0134	2.30
		120	5825.0189	3.24	5825.0163	2.80
		138	5825.0190	3.26	5825.0200	3.43
	20	102	5825.0101	1.73	5825.0175	3.00
		120	5825.0157	2.70	5825.0199	3.42
		138	5825.0175	3.00	5825.0105	1.80
	30	102	5825.0159	2.73	5825.0116	1.99
		120	5825.0152	2.61	5825.0167	2.87
		138	5825.0121	2.08	5825.0147	2.52
40	102	5825.0179	3.07	5825.0114	1.96	
	120	5825.0194	3.33	5825.0118	2.03	
	138	5825.0129	2.21	5825.0112	1.92	

The End