



# RADIO TEST REPORT

Test Report No. : 31KE0354-HO-01-B-R1

**Applicant** : Murata Manufacturing Co., Ltd.  
**Type of Equipment** : Communication Module  
**Model No.** : LBEE5ZSTNC  
**FCC ID** : VPYLBTN  
**Test regulation** : FCC Part 15 Subpart C: 2010  
**Test Result** : Complied

1. This test report shall not be reproduced in full or partial, without the written approval of UL Japan, Inc.
2. The results in this report apply only to the sample tested.
3. This sample tested is in compliance with the above regulation.
4. The test results in this report are traceable to the national or international standards.
5. This test report must not be used by the customer to claim product certification, approval, or endorsement by NVLAP, NIST, or any agency of the Federal Government.
6. This report is a revised version of 31KE0354-HO-01-B. 31KE0354-HO-01-B is replaced with this report.

**Date of test:** July 11 to 21, 2011

**Representative test engineer:**

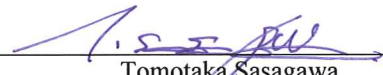
  
Tomotaka Sasagawa  
Engineer of WiSE Japan,  
UL Verification Service

**Approved by:**

  
Takahiro Hatakeda  
Leader of WiSE Japan,  
UL Verification Service



NVLAP LAB CODE: 200572-0

This laboratory is accredited by the NVLAP LAB CODE 200572-0, U.S.A. The tests reported herein have been performed in accordance with its terms of accreditation. \*As for the range of Accreditation in NVLAP, you may refer to the WEB address, <http://www.ul.com/japan/jpn/pages/services/emc/about/mark1/index.jsp#nvlap>

**UL Japan, Inc.**

**Head Office EMC Lab.**

4383-326 Asama-cho, Ise-shi, Mie-ken 516-0021 JAPAN

Telephone : +81 596 24 8116

Facsimile : +81 596 24 8124

13-EM-F0429

<b>CONTENTS</b>	<b>PAGE</b>
<b>SECTION 1: Customer information.....</b>	<b>3</b>
<b>SECTION 2: Equipment under test (E.U.T.).....</b>	<b>3</b>
<b>SECTION 3: Test specification, procedures &amp; results.....</b>	<b>4</b>
<b>SECTION 4: Operation of E.U.T. during testing.....</b>	<b>7</b>
<b>SECTION 5: Conducted Emission.....</b>	<b>9</b>
<b>SECTION 6: Radiated Spurious Emission .....</b>	<b>10</b>
<b>SECTION 7: Antenna Terminal Conducted Tests.....</b>	<b>11</b>
<b>APPENDIX 1: Photographs of test setup .....</b>	<b>12</b>
Conducted Emission.....	12
Radiated Spurious Emission.....	13
Worst Case Position .....	14
Below 1GHz: Horizontal: X-axis/ Vertical: X-axis .....	14
<b>APPENDIX 2: Data of EMI test.....</b>	<b>15</b>
Conducted Emission.....	15
20dB Bandwidth and Carrier Frequency Separation.....	17
Number of Hopping Frequency.....	20
Dwell time .....	22
Maximum Peak Output Power .....	25
Radiated Spurious Emission.....	26
Conducted Spurious Emission.....	35
Conducted Emission Band Edge compliance.....	47
99% Occupied Bandwidth.....	49
<b>APPENDIX 3: Test instruments .....</b>	<b>51</b>

## **SECTION 1: Customer information**

Company Name : Murata Manufacturing Co., Ltd.  
Address : 10-1, Higashikotari 1-chome, Nagaokakyo-shi, Kyoto 617-8555 Japan  
Telephone Number : +81-75-955-6735  
Facsimile Number : +81-75-955-6634  
Contact Person : Takaharu Kawakatsu

## **SECTION 2: Equipment under test (E.U.T.)**

### **2.1 Identification of E.U.T.**

Type of Equipment : Communication Module  
Model No. : LBEE5ZSTNC  
Serial No. : Refer to Section 4, Clause 4.2  
Rating : DC1.8V/3.6V  
Receipt Date of Sample : July 11, 2011  
Country of Mass-production : Japan  
Condition of EUT : Engineering prototype  
(Not for Sale: This sample is equivalent to mass-produced items.)  
Modification of EUT : No Modification by the test lab

### **2.2 Product Description**

#### **General Specification**

Clock frequency(ies) in the system : REF\_CLK: 38.4MHz, SLOW\_CLK: 32.768kHz  
Operating temperature range : -30 to +75 deg. C

#### **Radio Specification**

##### **WLAN 11b/g/n-20**

Radio Type : Transceiver  
Frequency of Operation : 2412-2462MHz  
Modulation : 11b: DSSS, 11g/n-20: OFDM  
Power Supply (radio part input) : DC3.6V  
Antenna type : Mono-pole antenna  
Antenna Gain : +0.8dBi

##### **Bluetooth**

Radio Type : Transceiver  
Frequency of Operation : 2402-2480MHz  
Modulation : FHSS  
Power Supply (radio part input) : DC3.6V  
Antenna type : Mono-pole antenna  
Antenna Gain : +0.8dBi

---

**UL Japan, Inc.**

**Head Office EMC Lab.**

4383-326 Asama-cho, Ise-shi, Mie-ken 516-0021 JAPAN

Telephone : +81 596 24 8116

Facsimile : +81 596 24 8124

## **SECTION 3: Test specification, procedures & results**

### **3.1 Test Specification**

Test Specification : FCC Part 15 Subpart C: 2010, final revised on December 6, 2010 and effective January 5, 2011

Title : FCC 47CFR Part15 Radio Frequency Device Subpart C Intentional Radiators  
Section 15.207 Conducted limits  
Section 15.247 Operation within the bands 902-928MHz,  
2400-2483.5MHz, and 5725-5850MHz

### **3.2 Procedures and results**

Item	Test Procedure	Specification	Worst Margin	Results	Remarks	
Conducted Emission	FCC: ANSI C63.4:2003 7. AC powerline conducted emission measurements IC: RSS-Gen 7.2.4	FCC: Section 15.207 ----- IC: RSS-Gen 7.2.4	QP 15.6dB, 4.96029MHz, L AV 15.2dB, 4.96029MHz, L	Complied	-	
Carrier Frequency Separation	FCC: FCC Public Notice DA 00-705 IC: -	FCC: Section15.247(a)(1) ----- IC: RSS-210 A8.1 (b)	See data.	Complied	Conducted	
20dB Bandwidth	FCC: FCC Public Notice DA 00-705 IC: -	FCC: Section15.247(a)(1) ----- IC: RSS-210 A8.1 (a)		-	Conducted	
Number of Hopping Frequency	FCC: FCC Public Notice DA 00-705 IC: -	FCC: Section15.247(a)(1)(iii) ----- IC: RSS-210 A8.1 (d)		Complied	Conducted	
Dwell time	FCC: FCC Public Notice DA 00-705 IC: -	FCC: Section15.247(a)(1)(iii) ----- IC: RSS-210 A8.1 (d)		Complied	Conducted	
Maximum Peak Output Power	FCC: FCC Public Notice DA 00-705 IC: RSS-Gen 4.8	FCC: Section15.247(a)(b)(1) ----- IC: RSS-210 A8.4 (2)		Complied	Conducted	
Spurious Emission & Band Edge Compliance	FCC: FCC Public Notice DA 00-705 IC: RSS-Gen 4.9	FCC: Section15.247(d) ----- IC: RSS-210 A8.5 RSS-Gen 6 and 7.2.3		4.4dB 72.362MHz, QP, Vert.	Complied	Conducted/ Radiated

Note: UL Japan, Inc.'s EMI Work Procedures No. 13-EM-W0420 and 13-EM-W0422.

\* In case any questions arise about test procedure, ANSI C63.4: 2003 is also referred.

**FCC 15.31 (e)**

The stable voltage (DC3.6V) is constantly provided with the EUT through the regulator installed in the end product. Therefore, the EUT complies with the requirement.

**FCC Part 15.203/212 Antenna requirement**

It is impossible for end users to replace the antenna, because it is soldered on the circuit board. Therefore, the equipment complies with the antenna requirement of Section 15.203/212.

**3.3 Addition to standard**

Item	Test Procedure	Specification	Worst margin	Results	Remarks
99% Occupied Bandwidth	IC: RSS-Gen 4.6.1	IC: RSS-Gen 4.6.1	N/A	-	Conducted

Other than above, no addition, exclusion nor deviation has been made from the standard.

**3.4 Uncertainty**

**EMI**

The following uncertainties have been calculated to provide a confidence level of 95% using a coverage factor k=2.

Test room (semi-anechoic chamber)	Conducted emission (+dB)
	150kHz-30MHz
No.1	3.1dB
No.2	3.3dB
No.3	3.7dB
No.4	3.2dB

Test room (semi-anechoic chamber)	Radiated emission						
	(3m*)(+dB)				(1m*)(+dB)		(0.5m*)(+dB)
	9kHz -30MHz	30MHz -300MHz	300MHz -1GHz	1GHz -10GHz	10GHz -18GHz	18GHz -26.5GHz	26.5GHz -40GHz
No.1	3.5dB	5.1dB	5.2dB	4.8dB	5.1dB	4.4dB	4.3dB
No.2	4.0dB	5.1dB	5.2dB	4.8dB	5.0dB	4.3dB	4.2dB
No.3	4.2dB	4.7dB	5.2dB	4.8dB	5.0dB	4.5dB	4.2dB
No.4	4.0dB	5.0dB	5.1dB	4.8dB	5.0dB	5.1dB	4.2dB

\*3m/1m/0.5m = Measurement distance

Power meter (+dB)	
Below 1GHz	Above 1GHz
1.0dB	1.0dB

Antenna terminal conducted emission and Power density (+dB)			Antenna terminal conducted emission (+dB)		Channel power (+dB)
Below 1GHz	1GHz-3GHz	3GHz-18GHz	18GHz-26.5GHz	26.5GHz-40GHz	
1.0dB	1.1dB	2.7dB	3.2dB	3.3dB	1.5dB

Conducted Emission test

The data listed in this test report has enough margin, more than the site margin.

Radiated emission test

The data listed in this report meets the limits unless the uncertainty is taken into consideration.

**UL Japan, Inc.**

**Head Office EMC Lab.**

4383-326 Asama-cho, Ise-shi, Mie-ken 516-0021 JAPAN

Telephone : +81 596 24 8116

Facsimile : +81 596 24 8124

### 3.5 Test Location

UL Japan, Inc. Head Office EMC Lab. \*NVLAP Lab. code: 200572-0  
4383-326 Asama-cho, Ise-shi, Mie-ken 516-0021 JAPAN  
Telephone : +81 596 24 8116 Facsimile : +81 596 24 8124

	FCC Registration Number	IC Registration Number	Width x Depth x Height (m)	Size of reference ground plane (m) / horizontal conducting plane	Other rooms
No.1 semi-anechoic chamber	313583	2973C-1	19.2 x 11.2 x 7.7m	7.0 x 6.0m	No.1 Power source room
No.2 semi-anechoic chamber	655103	2973C-2	7.5 x 5.8 x 5.2m	4.0 x 4.0m	-
No.3 semi-anechoic chamber	148738	2973C-3	12.0 x 8.5 x 5.9m	6.8 x 5.75m	No.3 Preparation room
No.3 shielded room	-	-	4.0 x 6.0 x 2.7m	N/A	-
No.4 semi-anechoic chamber	134570	2973C-4	12.0 x 8.5 x 5.9m	6.8 x 5.75m	No.4 Preparation room
No.4 shielded room	-	-	4.0 x 6.0 x 2.7m	N/A	-
No.5 semi-anechoic chamber	-	-	6.0 x 6.0 x 3.9m	6.0 x 6.0m	-
No.6 shielded room	-	-	4.0 x 4.5 x 2.7m	4.75 x 5.4 m	-
No.6 measurement room	-	-	4.75 x 5.4 x 3.0m	4.75 x 4.15 m	-
No.7 shielded room	-	-	4.7 x 7.5 x 2.7m	4.7 x 7.5m	-
No.8 measurement room	-	-	3.1 x 5.0 x 2.7m	N/A	-
No.9 measurement room	-	-	8.0 x 4.5 x 2.8m	2.0 x 2.0m	-
No.10 measurement room	-	-	2.6 x 2.8 x 2.5m	2.4 x 2.4m	-
No.11 measurement room	-	-	3.1 x 3.4 x 3.0m	2.4 x 3.4m	-

\* Size of vertical conducting plane (for Conducted Emission test) : 2.0 x 2.0m for No.1, No.2, No.3, and No.4 semi-anechoic chambers and No.3 and No.4 shielded rooms.

### 3.6 Test set up, Data of EMI, and Test instruments

Refer to APPENDIX.

## **SECTION 4: Operation of E.U.T. during testing**

### **4.1 Operating Mode(s)**

Bluetooth (BT): Transmitting (Tx), Payload: PRBS9  
Receiving (Rx)  
Inquiry

Details of Operating Mode(s)

<b>Test Item</b>	<b>Mode</b>	<b>Tested frequency</b>
Conducted Emission,	Tx (Hopping off) 3DH5	2480MHz
Spurious Emission (Conducted/Radiated)	Tx (Hopping off) DH5, 3DH5	2402MHz 2441MHz 2480MHz
Carrier Frequency Separation	Tx (Hopping on) DH5, 3DH5 Inquiry	2402MHz 2441MHz 2480MHz
20dB Bandwidth	Tx (Hopping off) DH5, 3DH5 Inquiry	2402MHz 2441MHz 2480MHz
Number of Hopping Frequency	Tx (Hopping on) DH5, 3DH5 Inquiry	-
Dwell time	Tx (Hopping on), -DH1, DH3, DH5 -3DH1, 3DH3, 3DH5 Inquiry	-
Maximum Peak Output Power	Tx (Hopping off) DH5, 3DH5 Inquiry	2402MHz 2441MHz 2480MHz
Band Edge Compliance (Conducted)	Tx DH5, 3DH5 -Hopping on -Hopping off	2402MHz 2480MHz
99% Occupied Bandwidth	Tx DH5, 3DH5 -Hopping on -Hopping off	2402MHz 2441MHz 2480MHz
*As a result of preliminary test, the formal test was performed with the above modes, which had the maximum payload length (except Dwell time test) *1) The mode was tested as a representative, because it had the highest power at antenna terminal test and noise level at the mode/channel was equivalent to that of other mode/tested frequency.		

EUT has the power settings by the software as follows;  
Power settings: 15dBm  
Software: HCI Tester Ver.: 3.0.0.5

This setting of software is the worst case.  
Any conditions under the normal use do not exceed the condition of setting.  
In addition, end users cannot change the settings of the output power of the product.

## 4.2 Configuration and peripherals

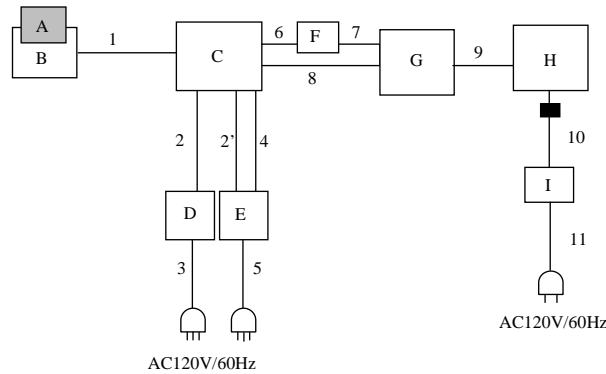

\*Cabling and setup(s) were taken into consideration and test data was taken under worse case conditions.

### Description of EUT

No.	Item	Model number	Serial number	Manufacturer	Remarks
A	Communication Module	LBEE5ZSTNC	001 *1) 002 *2)	Murata Manufacturing Co., Ltd.	EUT
B	Jig Board	-	-	Murata Manufacturing Co., Ltd.	EUT
C	Jig Board	-	-	Murata Manufacturing Co., Ltd.	-
D	DC Power Supply	PMC35-2A	13090501	KIKUSUI ELECTRONICS CORP.	*3)
E	DC Power Supply	PW18-1.3AT	09067054	KENWOOD	-
F	Converter	-	91211900	-	-
G	USB Hub	U2H-H4SSV	001884C	ELECOM	-
H	Personal Computer	TYPE 2973-GQ7	L3-03T2G	IBM	-
I	AC Adaptor	92P1020	11S92P1020Z1 Z9RM67H1YC	IBM	-

\*1) Used for Antenna Terminal Conducted test

\*2) Used for Conducted Emission and Radiated Emission tests

\*3) Used for Conducted Emission test only

### List of cables used

No.	Name	Length (m)	Shield		Remarks
			Cable	Connector	
1	Flat Cable	1.9 *1) 0.3 *2)	Unshielded	Unshielded	-
2	DC Cable	1.4	Unshielded	Unshielded	*3)
2'	DC Cable	1.4	Unshielded	Unshielded	-
3	AC Cable	2.9	Unshielded	Unshielded	*3)
4	DC Cable	1.4	Unshielded	Unshielded	-
5	AC Cable	1.8	Unshielded	Unshielded	-
6	RS-232C Cable	2.0	Shielded	Shielded	-
7	USB Cable	1.0	Shielded	Shielded	-
8	USB Cable	1.0	Shielded	Shielded	-
9	USB Cable	1.0	Shielded	Shielded	-
10	DC Cable	1.8	Shielded	Shielded	-
11	AC Cable	1.0	Unshielded	Unshielded	-

\*1) Used for Radiated Emission (above 1GHz) test

\*2) Used for other tests than Radiated Emission (above 1GHz)

\*3) Used for Conducted Emission test only

**UL Japan, Inc.**

**Head Office EMC Lab.**

4383-326 Asama-cho, Ise-shi, Mie-ken 516-0021 JAPAN

Telephone : +81 596 24 8116

Facsimile : +81 596 24 8124



## **SECTION 5: Conducted Emission**

### **Test Procedure and conditions**

EUT was placed on a wooden table of nominal size, 1.0m by 1.5m, raised 0.8m above the conducting ground plane. The rear of tabletop was located 40cm to the vertical conducting plane. The rear of EUT, including peripherals aligned and flushed with rear of tabletop. All other surfaces of tabletop were at least 80cm from any other grounded conducting surface. EUT was located 80cm from a Line Impedance Stabilization Network (LISN)/ Artificial mains Network (AMN) and excess AC cable was bundled in center.

For the tests on EUT with other peripherals (as a whole system)

I/O cables that were connected to the peripherals were bundled in center. They were folded back and forth forming a bundle 30cm to 40cm long and were hanged at a 40cm height to the ground plane. All unused 50ohm connectors of the LISN(AMN) were resistivity terminated in 50ohm when not connected to the measuring equipment.

The AC Mains Terminal Continuous disturbance Voltage has been measured with the EUT in a Semi Anechoic Chamber . The EUT was connected to a LISN (AMN).

An overview sweep with peak detection has been performed.

The test results and limit are rounded off to one decimal place, so some differences might be observed.

**Detector** : QP and AV  
**Measurement range** : 0.15-30MHz  
**Test data** : APPENDIX  
**Test result** : Pass

## **SECTION 6: Radiated Spurious Emission**

### **Test Procedure**

EUT was placed on a urethane platform of nominal size, 1.0m by 1.0m, raised 0.8m above the conducting ground plane. The Radiated Electric Field Strength has been measured in a Semi Anechoic Chamber with a ground plane.

The height of the measuring antenna varied between 1 and 4m and EUT was rotated a full revolution in order to obtain the maximum value of the electric field strength.

The measurements were performed for both vertical and horizontal antenna polarization with the Test Receiver, or the Spectrum Analyzer.

The measurements were made with the following detector function of the test receiver and the Spectrum analyzer (in linear mode).

The test was made with the detector (RBW/VBW) in the following table.

When using Spectrum analyzer, the test was made with adjusting span to zero by using peak hold.

### **Test Antennas are used as below;**

Frequency	Below 30MHz	30MHz to 300MHz	300MHz to 1GHz	Above 1GHz
Antenna Type	Loop	Biconical	Logperiodic	Horn

In any 100kHz bandwidth outside the restricted band in which the spread spectrum intentional radiator is operating, the radio frequency power that is produced by the intentional radiator confirmed 20dB below that in the 100kHz bandwidth within the band that contains the highest level of the desired power, based on a radiated measurement.

**20dBc was applied to the frequency over the limit of FCC 15.209 / Table 5 of RSS-Gen 7.2.5 (IC) and outside the restricted band of FCC15.205 / Table 3 of RSS-Gen 7.2.2 (IC).**

Frequency	Below 1GHz	Above 1GHz		20dBc
Instrument used	Test Receiver	Spectrum Analyzer		Spectrum Analyzer
Detector	QP	PK	AV	PK
IF Bandwidth	BW 120kHz(T/R)	RBW: 1MHz VBW: 3MHz	RBW: 1MHz VBW: 10Hz or RBW: 1MHz VBW: 270Hz *1)	RBW: 100kHz VBW: 300kHz (S/A)
Test Distance	3m	3m (below 10GHz), 1m*2) (above 10GHz)		3m (below 10GHz), 1m*2) (above 10GHz),

\*1) Used for the band edge of the carrier and the harmonics that can be measured. The VBW is based on the inverse of the duty cycle (see Appendix).

\*2) Distance Factor:  $20 \times \log(3.0\text{m}/1.0\text{m}) = 9.5\text{dB}$

- The carrier level and noise levels were confirmed at each position of X, Y and Z axes of EUT to see the position of maximum noise, and the test was made at the position that has the maximum noise.

The test results and limit are rounded off to one decimal place, so some differences might be observed.

**Measurement range : 30M-25GHz**  
**Test data : APPENDIX**  
**Test result : Pass**

**UL Japan, Inc.**

**Head Office EMC Lab.**

4383-326 Asama-cho, Ise-shi, Mie-ken 516-0021 JAPAN

Telephone : +81 596 24 8116

Facsimile : +81 596 24 8124

## **SECTION 7: Antenna Terminal Conducted Tests**

### **Test Procedure**

The tests were made with below setting connected to the antenna port.

<b>Test</b>	<b>Span</b>	<b>RBW</b>	<b>VBW</b>	<b>Sweep time</b>	<b>Detector</b>	<b>Trace</b>	<b>Instrument used</b>
20dB Bandwidth	3MHz	30kHz	100kHz	Auto	Peak	Max Hold	Spectrum Analyzer
99% Occupied Bandwidth	Enough width to display 20dB Bandwidth	1 to 3% of Span	Three times of RBW	Auto	Peak	Max Hold	Spectrum Analyzer
Maximum Peak Output Power	-	-	-	Auto	Peak	-	Power Meter (Sensor: 50MHz BW)
Carrier Frequency Separation	3MHz	30kHz	100kHz	Auto	Peak	Max Hold	Spectrum Analyzer
Number of Hopping Frequency	30MHz	300kHz	1MHz	Auto	Peak	Max Hold	Spectrum Analyzer
Dwell Time	Zero Span	100kHz, 1MHz	300kHz, 3MHz	As necessary capture the entire dwell time per hopping channel	Peak	Max Hold	Spectrum Analyzer
Conducted Spurious Emission *1)	9kHz to 150kHz	200Hz	620Hz	Auto	Peak	Max Hold	Spectrum Analyzer
	150kHz to 30MHz	9.1kHz	27kHz				
	30MHz to 25GHz (Less or equal to 5GHz)	100kHz	300kHz				
Conducted Spurious Emission Band Edge compliance	20MHz	300kHz	1MHz	Auto	Peak	Max Hold	Spectrum Analyzer

\*1) In the frequency range below 30MHz, RBW was narrowed to separate the noise contents. Then, wide-band noise near the limit was checked separately, however the noise was not detected as shown in the chart.(9kHz-150kHz:RBW=200Hz, 150kHz-30MHz:RBW=9.1kHz)

The test results and limit are rounded off to two decimals place, so some differences might be observed.

**Test data** : APPENDIX  
**Test result** : Pass