



Gobi3000™ Module FCC Part 22, 24 & 27 Conducted Test Report

80-N2162-203 Rev B

July 14, 2010

**Submit technical questions to:
regulatory.support@qualcomm.com**

QUALCOMM is a registered trademark of QUALCOMM Incorporated in the United States and may be registered in other countries. Other product and brand names may be trademarks or registered trademarks of their respective owners. CDMA2000 is a registered certification mark of the Telecommunications Industry Association, used under license, ARM is a registered trademark of ARM Limited. QDSP is a registered trademark of QUALCOMM Incorporated in the United States and other countries.

This technical data may be subject to U.S. and international export, re-export, or transfer (“export”) laws. Diversion contrary to U.S. and international law is strictly prohibited.

QUALCOMM Incorporated
5775 Morehouse Drive
San Diego, CA 92121-1714
U.S.A.

Copyright © 2010 QUALCOMM Incorporated.
All rights reserved.

July 14, 2010

Gobi3000™ Module FCC Part 22, 24 & 27 Conducted Test Report
80-N2162-203 Rev B

Gobi3000™ Module FCC Part 22, 24 & 27 Conducted Test Report

FCC Part 22, 24 & 27 Certification	
FCC ID:	J9CGOBI3000
Model:	Gobi3000

STATEMENT OF CERTIFICATION	
<i>The data, data evaluation and equipment configuration represented herein are a true and accurate representation of the measurements of the sample's radio frequency interference emissions characteristics as of the dates and at the times of the test under the conditions herein specified.</i>	
Test performed by:	QUALCOMM Incorporated 5775 Morehouse Drive San Diego, CA 92121-1714
Report Prepared by:	QUALCOMM Incorporated 5775 Morehouse Drive San Diego, CA 92121-1714
Tests that required an OATS site were performed by Compliance Certification Services.	

Table of Contents

1. Introduction and Purpose..... 1

2. Description of Device Under Test2

3. Test Summary 2

4. RF Power Output Verification..... 2

4.1 Base Station Emulator Settings and Measurement Procedures.....3

4.1.1 CDMA2000 1xEV-DO Max Power setup3

4.1.2 WCDMA/HSDPA/HSUPA Max Power setup6

4.1.3 GSM/GPRS/EDGE Max Power setup9

4.2 Maximum Transmit Power Test Results.....9

4.2.1 CDMA2000 1xEV-DO Maximum Transmit power9

4.2.2 WCDMA/HSDPA/HSUPA Maximum Transmit Power10

4.2.3 GSM/GPRS/EDGE Maximum Transmit Power10

5. Occupied Bandwidth 11

5.1 Occupied Bandwidth Test Procedure 11

5.2 Occupied Bandwidth Test Results12

5.2.1 GSM Occupied Bandwidth Plots15

5.2.2 UMTS Occupied Bandwidth Plots21

5.2.3 CDMA2000 Occupied Bandwidth Plots.....30

6. Band Edge Compliance 39

Test Procedures39

6.1 Band Edge Compliance Test Results.....40

6.1.1 GSM Band Edge Plots.....43

6.1.2 UMTS Band Edge Plots.....47

6.1.3 CDMA2000 Band Edge Plots.....53

7. Out of Band Emission at Antenna Terminals..... 59

7.1 Out of Band Emission Test Procedure.....59

7.2 Emission Test Results.....60

7.2.1 GSM Emissions Plots62

7.2.2 UMTS Emissions Plots.....74

7.2.3 CDMA2000 Emissions Plots83

8. Frequency Stability..... 89

8.1 Frequency Stability Test Procedure89

8.2 Frequency Stability Test Results90

9. Test Equipment and Firmware 99

1. Introduction and Purpose

This document provides FCC test data for the Qualcomm Gobi3000™ module wireless embedded modem. The test results included in this report are limited to conducted test results. Radiated testing was performed at Compliance Certification Services in Fremont, CA, and the test results are contained in the Gobi3000 Module FCC Part 22, 24 & 27 Radiated Test Report.

2. Description of Device Under Test

The Gobi3000 module is a universal embedded-data-connectivity modem in the form of a PCI Express mini-card and the associated software suite for the notebook PC application. The Gobi3000 module supports the modes and frequency bands shown in the following table.

Mode	Equipment Category	Band Name	Available in U.S. / Canada	Transmitter Range (MHz)	Receiver Range (MHz)
GPRS/EDGE	GPRS/EDGE Cat 10	850 MHz - US Cellular	Yes	824-849	869-894
		900 MHz - EGSM	No	880-915	925-960
		1800 MHz - DCS	No	1710-1785	1805-1880
		1900 MHz - US PCS	Yes	1850-1910	1930-1990
UMTS/HSPA+	R7 HSDPA Cat 10 R6 HSUPA Cat 6	Band 1 2.1 GHz	No	1920-1980	2110-2170
		Band 2 1900 MHz	Yes	1850-1910	1930-1990
		Band 4 AWS	Yes	1710-1755	2110-2155
		Band 5 850 MHz	Yes	824-849	869-894
		Band 6 800 MHz (Japan)	No	830-840	875-885
		Band 8 900 MHz	No	880-915	925-960
		BC0 850 MHz	Yes	824-849	869-894
CDMA2000	EVDO Release 0 EVDO Revision A	BC1 1900 MHz	Yes	1850-1910	1930-1990
GPS	1x	GPS L1	Yes	N/A	1570-1590

The module contains two RF ports. The first port is the primary transmit/receive and the 2nd RF port is used for the RX diversity and GPS receivers. For conducted compliance testing, the module was tested inside a test fixture that provide power via an external cable. A RF cable was connected to the primary antenna port for RF measurements.

For FCC and IC compliance testing, the Gobi3000 module was only tested in bands used in the regions as noted in the table.

The DUT is a pre-production sample intentionally calibrated with transmit power higher than the nominal factory setpoints to represent worst case data for manufactured modules.

3. Test Summary

FCC/IC Rule	Description of Test	Result	Page
§2.1046	RF Power Output	Complies	12
§2.1049	Occupied Bandwidth	Complies	14
§22.359, 24.238, 27.53(g)	Band Edge Requirement	Complies	29
§2.1051, 22.917, 24.238(a), 27.53	Out of Band Emission at Antenna Terminals	Complies	41
§2.1055, 22.355, 24.235, 27.54	Frequency Stability vs. Temperature vs. Voltage	Complies	57
§1.1310, 2.1091	RF Exposure	Complies	See MPE Report
§2.1053, 22.917, 24.238(a), 27.55	Field Strength of Spurious Radiation	Complies	See Radiated Test Report

4. RF Power Output Verification

FCC:	§ 2.1046
Limit:	n/a
DUT SN	N10F6XTXR

4.1 Base Station Emulator Settings and Measurement Procedures

As shown in the figure below, connect the transmitter output of the Gobi3000 module to the communication test set (Agilent 8960) and configure it to operate at maximum power in a call.

Measure the power at three equally spaced operating frequencies for each band.

Use the build-in power measurement capability in the 8960 box to measure CDMA 1x/1xEVDO and GPRS/EGPRS/UMTS conducted power output.

The relevant cable loss is measured for the specific frequencies under test and added as a correction factor for all the tests.



4.1.1 CDMA2000 1xEV-DO Max Power setup

Measure the power at Ch1013, 384 and 777 for US cell; Ch25, 600 and 1175 for US PCS band.

1xRTT

Use CDMA2000 Rev 6 protocol in the call box 8960.

- 1) Test for Reverse/Forward TCH RC1, Reverse/Forward TCH RC2, and RC3 Reverse FCH and demodulation of RC 3, 4 and 5.
 - a. Set up a call using Fundamental Channel Test Mode 1 (RC1, SO 2) with 9600 bps data rate only.
 - b. As per C.S0011 or TIA/EIA-98-F Table 4.4.5.2-1, set the test parameters as shown in Table 4-1.
 - c. Send continuously '0' power control bits to the Gobi3000 module.
 - d. Measure the output power at Gobi3000 module antenna connector as recorded on the power meter with values corrected for cables losses.
 - e. Repeat step b through d for Fundamental Channel Test Mode:
 - i. RC1, SO55
 - ii. RC2, SO9
 - iii. RC2, SO55
 - iv. RC3, SO55
- 2) Test for RC 3 Reverse FCH, RC3 Reverse SCH0 and demodulation of RC 3, 4 and 5.
 - a. Set up a call using Supplemental Channel Test Mode 3 (RC 3, SO 32) with 9600 bps Fundamental Channel and 9600 bps SCH0 data rate.

- b. As per C.S0011 or TIA/EIA-98-F Table 4.4.5.2-2, set the test parameters as shown in Table 4-2.
- c. Send alternating ‘0’ and ‘1’ power control bit to the Gobi3000 module
- d. Determine the active channel configuration. If the desired channel configuration is not the active channel configuration, increase \hat{I}_{or} by 1 dB and repeat the verification. Repeat this step until the desired channel configuration becomes active.
- e. Measure the output power at the Gobi3000 module antenna connector.
- f. Decrease \hat{I}_{or} by 0.5 dB.
- g. Determine the active channel configuration. If the active channel configuration is the desired channel configuration, measure the output power at the Gobi3000 module antenna connector.
- h. Repeat step f and g until the output power no longer increases or the desired channel configuration is no longer active. Record the highest output power achieved with the desired channel configuration active.
- i. Repeat step a through h ten times and average the result.

Table 4-1 Parameters for Max. Power with a single traffic code channel, SR1

Parameter	Units	Value
\hat{I}_{or}	dBm/1.23 MHz	-104
$\frac{\text{Pilot } E_c}{I_{or}}$	dB	-7
$\frac{\text{Traffic } E_c}{I_{or}}$	dB	-7.4

Table 4-2 Parameters for Max. Power with multiple traffic code channel, SR1

Parameter	Units	Value
$\frac{\text{Pilot } E_c}{I_{or}}$	dB	-7
$\frac{\text{Traffic } E_c}{I_{or}}$	dB	-7.4

1xEV-DO

1) Use 1xEV-DO Rel 0 protocol in the call box 8960.

a. FTAP

- Select Test Application Protocol to FTAP
- Set FTAP Rate to 307.2 kbps (2 Slot, QPSK)
- Generator Info -> Termination Parameters -> Max Forward Packet Duration -> 16 Slots
- Set \hat{I}_{or} to -60 dBm/1.23 MHz
- Send continuously '0' power control bits
- Measure the power at Gobi3000 module antenna connector

b. RTAP

- Select Test Application Protocol to RTAP
- Set RTAP Rate to 9.6 kbps
- Generator Info -> Termination Parameters -> Max Forward Packet Duration -> 16 Slots
- Set \hat{I}_{or} to -60 dBm/1.23 MHz
- Send continuously '0' power control bits
- Measure the power at Gobi3000 module antenna connector
- Repeat above steps for RTAP Rate = 19.2 kbps, 38.4 kbps, 76.8 kbps and 153.6 kbps respectively

2) Use 1xEV-DO Rev A protocol in the call box 8960

a. FETAP

- Select Test Application Protocol to FETAP
- Set FETAP Rate to 307.2 kbps (2 Slot, QPSK)
- Generator Info -> Termination Parameters -> Max Forward Packet Duration -> 16 Slots
- Set \hat{I}_{or} to -60 dBm/1.23 MHz
- Send continuously '0' power control bits
- Measure the power at Gobi3000 module antenna connector

b. RETAP

- Select Test Application Protocol to RETAP
- F-Traffic Format -> 4 (1024, 2, 128) Canonical (307.2k, QPSK)
- Set R-Data Pkt Size to 128
- Protocol Subtype Config -> Release A Physical Layer Subtype -> Subtype 2

->PL Subtype 2 Access Channel MAC Subtype -> Default
(Subtype 0)

- Generator Info -> Termination Parameters -> Max Forward Packet Duration
-> 16 Slots

->ACK R-Data After -> Subpacket 0 (All ACK)

- Set \hat{I}_{or} to -60 dBm/1.23 MHz
- Send continuously '0' power control bits
- Measure the power at Gobi3000 module antenna connector
- Repeat above steps for R-Data Pkt Size = 256, 512, 768, 1024, 1536, 2048, 3072, 4096, 6144, 8192, 12288 respectively.

4.1.2 WCDMA/HSDPA/HSUPA Max Power setup

Configure the call box to support all WCDMA tests in respect to the 3GPP 34.121 (listed in Table 4-3). Measure the power at Ch4132, 4182 and 4233 for US cell; Ch9262, 9400 and 9538 for US PCS band.

For Rel99 per 3GPP 35.121 5.2

- Set a Test Mode 1 loop back with a 12.2kbps Reference Measurement Channel (RMC)
- Set and send continuously Up power control commands to the Gobi3000 module.
- Measure the power at the Gobi3000 module antenna connector using the power meter with average detector

For HSDPA Rel 7 3 per GPP 35.121 5.2AA

- Establish a Test Mode 1 loop back with both 1 12.2kbps RMC channel and an H-Set1 Fixed Reference Channel (FRC). With the 8820 this is accomplished by setting the signal Channel Coding to "Fixed Reference Channel" and configuring for HSET-1 QKSP.
- Set beta values and HSDPA settings for HSDPA Subtest1 according to Table 4-3
- Send continuously Up power control commands to the Gobi3000 module
- Measure the power at the Gobi3000 module antenna connector using the power meter with modulated average detector
- Repeat the measurement for the HSDPA Subtest2, 3 and 4 as given in Table 4-3

For HSUPA Rel 6 per 3GPP 35.121 5.2B

- Use UL RMC 12.2kbps and FRC H-Set1 QPSK, Test Mode 1 loop back. With the 8820 this is accomplished by setting the signal Channel Coding to "E-DCH Test Channel" and configuring the equipment category to Cat5_10ms.
- Set the Absolute Grant for HSUPA Subtest1 according to Table 4-3
- Set the Gobi3000 module power to be at least 5dB lower than the Maximum output power

- Send power control bits to give one TPC_cmd = +1 command to the UNDP. If UNDP doesn't send any E-DPCH data with decreased E-TFCI within 500ms, then repeat this process until the decreased E-TFCI is reported.
- Confirm that the E-TFCI transmitted by the Gobi3000 module is equal to the target E-TFCI in Table 4-3. If the E-TFCI transmitted by the Gobi3000 module is not equal to the target E-TFCI, then send power control bits to give one TPC_cmd = -1 command to the UE. If UE sends any E-DPCH data with decreased E-TFCI within 500 ms, send new power control bits to give one TPC_cmd = -1 command to the UE. Then confirm that the E-TFCI transmitted by the UE is equal to the target E-TFCI in Table 4-3. If the E-TFCI transmitted by the UE is not equal to the target E-TFCI, then fail the UE
- Measure the power using the power meter with an average detector
- Repeat the measurement for the HSUPA Subtest2, 3 and 4 as given in Table 4-3
- Test case 5 is tested using all up bits for maximum output power per 34.521.

Table 4-3 3GPP Rel99/HSPA Subtest Settings

Subtest	Mode	Loopback Mode	Rel99 RMC	HSDPA FRC	HSUPA Test	Common Settings		CM	MPR	Power Class 3 limit	HSDPA Specific Settings						HSUPA Specific Settings			HSUPA Additional Info					
						β_c	β_d				Δ ACK	Δ NAK	Δ CQI	Ack-Nack repetition factor	CQI Feedback [Table 5.2B.4]	CQI Repetition Factor [Table 5.2B.4]	Ahs = β_{hs}/β_c	Δ E-DPCCH	Δ HARQ	AG Index	ETFCI (from 34.121 Table C.11.1.3)	Associated Max UL Data Rate kbps			
1	Rel99	Test Mode1	12.2kbps	-	-			-		24 (+1.7/-3.7 dB)															
1	Rel6 HSDPA	Test Mode1	12.2kbps	H-Set1	-	2/15	15/15	0	0	24 (+1.7/-3.7 dB)	8	8	8	3	4ms	2	30/15							-	
2	Rel6 HSDPA	Test Mode1	12.2kbps	H-Set1	-	12/15	15/15	1	0	24 (+1.7/-3.7 dB)	8	8	8	3	4ms	2	30/15								-
3	Rel6 HSDPA	Test Mode1	12.2kbps	H-Set1	-	15/15	8/15	15	0.5	23.5 (+2.2/-3.7 dB)	8	8	8	3	4ms	2	30/15								-
4	Rel6 HSDPA	Test Mode1	12.2kbps	H-Set1	-	15/15	4/15	15	0.5	23.5 (+2.2/-3.7 dB)	8	8	8	3	4ms	2	30/15								-
1	Rel6 HSUPA	Test Mode1	12.2kbps	H-Set1	HSUPA Loopback	11/15	15/15	1	0	24 (+1.7/-3.7 dB)	8	8	8	3	4ms	2	30/15	6	0	20	75			242.1	
2	Rel6 HSUPA	Test Mode1	12.2kbps	H-Set1	HSUPA Loopback	6/15	15/15	3	2	22 (+3.7/-3.7 dB)	8	8	8	3	4ms	2	30/15	8	0	12	67			174.9	
3	Rel6 HSUPA	Test Mode1	12.2kbps	H-Set1	HSUPA Loopback	15/15	9/15	2	1	23 (+2.7/-3.7 dB)	8	8	8	3	4ms	2	30/15	8	0	15	92			482.8	
4	Rel6 HSUPA	Test Mode1	12.2kbps	H-Set1	HSUPA Loopback	2/15	15/15	3	2	22 (+3.7/-3.7 dB)	8	8	8	3	4ms	2	30/15	5	0	17	71			205.8	
5	Rel6 HSUPA	Test Mode1	12.2kbps	H-Set1	HSUPA Loopback	15/15	15/15	1	0	24 (+1.7/-3.7 dB)	8	8	8	3	4ms	2	30/15	7	0	21	81			308.9	

HSUPA Subtest 1,2,4,5

- Reference E-TFCIs	5 E-TFCIs
- Reference E-TFCI	11
- Reference E-TFCI PO	4
- Reference E-TFCI	67
- Reference E-TFCI PO	18
- Reference E-TFCI	71
- Reference E-TFCI PO	23
- Reference E-TFCI	75
- Reference E-TFCI PO	26
- Reference E-TFCI	81
- Reference E-TFCI PO	27

HSUPA Subtest 3

- Reference E-TFCIs	2 E-TFCIs
- Reference E-TFCI	11
- Reference E-TFCI PO	4
- Reference E-TFCI	92
- Reference E-TFCI PO	18

4.1.3 GSM/GPRS/EDGE Max Power setup

Configure the 8820B box to support GMSK and 8PSK call respectively, and set one timeslot transmission for GMSK GSM/GPRS and 8PSK EDGE. Measure and record power outputs for both modulations.

4.2 Maximum Transmit Power Test Results

4.2.1 CDMA2000 1xEV-DO Maximum Transmit power

Mode	Test Case			BC0 (850MHz) Channel Power (dBm)			BC1 (1900MHz) Channel (dBm)		
	#	FWD RC/TAP	REV RC/TAP	1013	384	777	25	600	1175
1x	1	RC1	RC1 (SO2)	24.46	24.46	24.29	24.52	24.44	24.32
	2	RC1	RC1 (SO55)	24.52	24.49	24.34	24.48	24.48	24.43
	3	RC2	RC2 (SO9)	24.55	24.37	24.26	24.51	24.33	24.46
	4	RC2	RC2 (SO55)	24.57	24.57	24.35	24.30	24.38	24.49
	5	RC3	RC3 (SO55)	24.56	24.62	24.57	24.64	24.57	24.52
	6	RC3	RC3 (SO32)	24.22	24.35	24.45	24.40	24.36	24.48
1xEVDO Rel0	7a	FTAP Rate = 307kbps (2 slot, QPSK)	RTAP rate = 9.6kbps	24.44	24.29	24.22	24.46	24.29	24.47
	7b		RTAP rate = 19.2kbps	24.43	24.43	24.19	24.39	24.44	24.49
	7c		RTAP rate = 38.4kbps	24.38	24.46	24.29	24.36	24.27	24.38
	7d		RTAP rate = 76.8kbps	24.46	24.29	24.22	24.41	24.11	24.32
	7e		RTAP rate = 153.6kbps	24.49	24.54	24.59	24.48	24.37	24.46
1xEVDO RevA	8a	FETAP rate = 307kbps (2 slot, ACK channel is transmitted at all the slots)	RETAP - payload size = 128	24.34	24.51	24.36	24.37	24.42	24.31
	8b		RETAP - payload size = 256	24.46	24.51	24.38	24.41	24.47	24.54
	8c		RETAP - payload size = 512	24.33	24.48	24.36	24.37	24.38	24.29
	8d		RETAP - payload size = 768	24.42	24.49	24.39	24.37	24.41	24.44
	8e		RETAP - payload size = 1024	24.29	24.35	24.28	24.44	24.41	24.27
	8f		RETAP - payload size = 1536	24.36	24.37	24.47	24.45	24.31	24.27
	8g		RETAP - payload size = 2048	24.48	24.52	24.51	24.47	24.53	24.34
	8h		RETAP - payload size = 3072	24.39	24.45	24.44	24.39	24.48	24.28
	8i		RETAP - payload size = 4096	24.54	24.47	24.42	24.44	24.39	24.27
	8j		RETAP - payload size = 6144	24.46	24.43	24.39	24.52	24.42	24.25
	8k		RETAP - payload size = 8192	24.45	24.48	24.39	24.36	24.46	24.24
	8l		RETAP - payload size = 12288	24.37	24.49	24.36	24.47	24.51	24.22

Note: All measurements are based on an average detector

4.2.2 WCDMA/HSDPA/HSUPA Maximum Transmit Power

Mode	3GPP Subtest	Band V (800 MHz) Channel Power (dBm)			Band IV (1700 MHz) Channel Power (dBm)			Band II (1900MHz) Channel Power (dBm)			MPR
		4132	4182	4233	1312	1427	1513	9262	9400	9538	
Rel99	1	24.36	24.23	24.48	24.58	24.34	24.56	23.08	24.32	24.52	
Rel6 HSDPA	1	23.48	23.63	23.75	23.66	23.57	23.62	23.32	23.75	24.47	0
	2	23.43	23.32	23.52	24.26	24.32	24.38	22.92	23.68	24.36	0
	3	23.42	23.36	24.26	23.96	24.22	24.00	20.01	22.54	23.65	0.5
	4	23.45	23.59	23.50	24.05	24.21	24.24	19.55	22.14	23.65	0.5
Rel6 HSUPA	1	24.08	24.31	23.75	23.71	23.38	24.04	24.42	24.68	24.27	0
	2	23.89	23.77	23.69	22.70	22.98	23.07	23.44	23.77	24.31	2
	3	23.93	23.82	23.41	23.20	23.08	23.10	23.67	24.09	23.98	1
	4	23.87	23.9	23.99	23.39	23.48	23.32	24.21	24.19	24.43	2
	5	24.44	24.45	23.55	23.21	23.26	23.36	24.09	24.33	24.51	0

Note: All measurements are based on an average detector

Note: The MPR has been implemented into the Gobi3000 module per the 3GPP standard.

4.2.3 GSM/GPRS/EDGE Maximum Transmit Power

Mode	GSM850 Channel Peak Power (dBm)			GSM1900 Channel Peak Power (dBm)			Modulation
	128	190	251	512	661	810	
GPRS (1 UL slot)	32.73	32.88	33.04	30.18	30.12	30.12	GMSK
GPRS (2 UL slot)	32.50	32.62	32.79	28.49	29.91	30.79	GMSK
EGPRS	27.25	27.18	27.21	26.23	27.12	27.30	8PSK

Note: All measurements are based on a peak detector

5. Occupied Bandwidth

FCC:	§2.1049		
Limit:	n/a		
DUT SN	N10F6XTXR		
Modes Tested	CDMA 1x / 1x-EVDO	WCDMA/HSPA	GSM/GPRS/EDGE
	RC3 SO55 Rel 0, RTAP rate = 153.6kbps Rev A, RETAP payload = 4096	Rel 99 Rel 6 HSUPA, Subtest 5	GSM EDGE

5.1 Occupied Bandwidth Test Procedure

As the figure below indicates, the transmitter output is connected to a calibrated coaxial cable and coupler. The other end of coupler was connected to the spectrum analyzer. Measured the occupied bandwidth (defined as the 99% power bandwidth) with the appropriate personality features integrated in the PSA.

An 8960 call box was used for CDMA 1x/1x-EVDO and UMTS measurements.

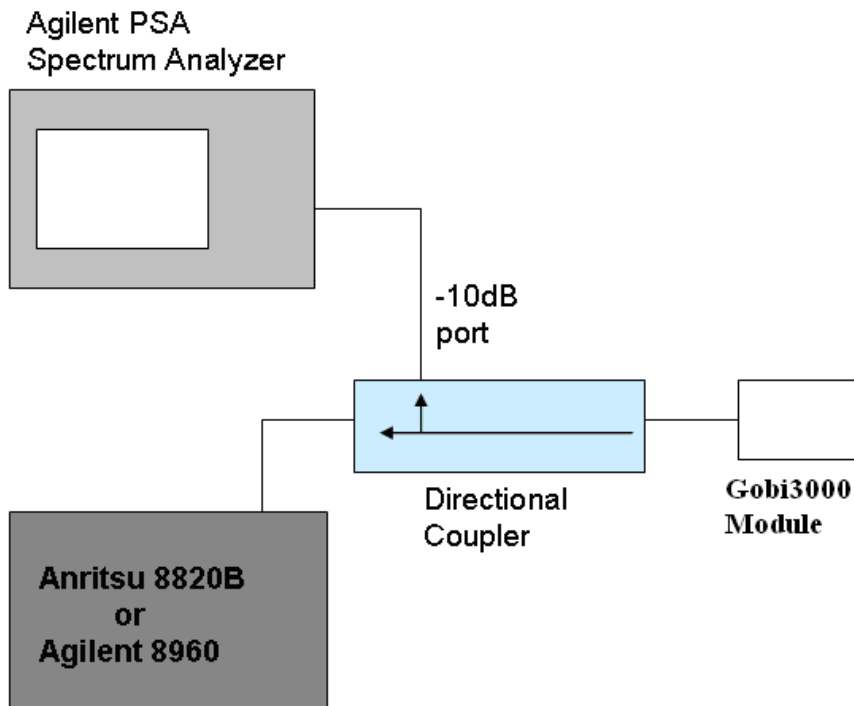

5.2 Occupied Bandwidth Test Results

The occupied bandwidth was measured at low, mid and high channel in each band.

Mode		Frequency (MHz)	Channel	99% Occupied Bandwidth (kHz)	Corresponding Plot number
GSM/ GPRS/ EDGE	GMSK	824.2	128 (low)	241.03	Plot 5.2 - 1
		836.6	190 (mid)	243.49	Plot 5.2 - 2
		848.8	251 (high)	242.18	Plot 5.2 - 3
		1850.2	512 (low)	240.56	Plot 5.2 - 4
		1880	661 (mid)	241.63	Plot 5.2 - 5
		1909.8	810 (high)	238.09	Plot 5.2 - 6
	8PSK	824.2	128 (low)	246.87	Plot 5.2 - 7
		836.6	190 (mid)	243.80	Plot 5.2 - 8
		848.8	251 (high)	244.71	Plot 5.2 - 9
		1850.2	512 (low)	242.91	Plot 5.2 - 10
		1880	661 (mid)	243.31	Plot 5.2 - 11
		1909.8	810 (high)	243.50	Plot 5.2 - 12

Mode		Frequency (MHz)	Channel	99% Occupied Bandwidth (MHz)	Plot number
WCDMA/ HSDPA/ HSUPA	Rel 99	1712.4	1312 (low)	4.1286	Plot 5.2 - 13
		1735.4	1427 (mid)	4.1348	Plot 5.2 - 14
		1752.6	1513 (high)	4.1457	Plot 5.2 - 15
		826.4	4132 (low)	4.1369	Plot 5.2 - 16
		836.4	4182 (mid)	4.1362	Plot 5.2 - 17
		846.6	4233 (high)	4.1300	Plot 5.2 - 18
		1852.4	9262 (low)	4.1352	Plot 5.2 - 19
		1880	9400 (mid)	4.1405	Plot 5.2 - 20
		1907.5	9538 (high)	4.1595	Plot 5.2 - 21
	HSUPA Rel 6 Subtest 5	1712.4	1312 (low)	4.1403	Plot 5.2 - 22
		1735.4	1427 (mid)	4.1417	Plot 5.2 - 23
		1752.6	1513 (high)	4.1434	Plot 5.2 - 24
		826.4	4132 (low)	4.1219	Plot 5.2 - 25
		836.4	4182 (mid)	4.1376	Plot 5.2 - 26
		846.6	4233 (high)	4.1301	Plot 5.2 - 27
		1852.4	9262 (low)	4.1400	Plot 5.2 - 28
		1880	9400 (mid)	4.1502	Plot 5.2 - 29
		1907.5	9538 (high)	4.1496	Plot 5.2 - 30

Mode		Frequency (MHz)	Channel	99% Occupied Bandwidth (MHz)	Plot number
CDMA1x/ 1x-EVDO	RC3 SO55	824.7	1013 (low)	1.2701	Plot 5.2 - 31
		836.52	384 (mid)	1.2743	Plot 5.2 - 32
		848.31	777 (high)	1.2727	Plot 5.2 - 33
		1851.25	25 (low)	1.2769	Plot 5.2 - 34
		1880	600 (mid)	1.2650	Plot 5.2 - 35
		1908.75	1175 (high)	1.2826	Plot 5.2 - 36
	Rel 0 RTAP rate = 153.6kbps	824.7	1013 (low)	1.2709	Plot 5.2 - 37
		836.52	384 (mid)	1.2713	Plot 5.2 - 38
		848.31	777 (high)	1.2675	Plot 5.2 - 39
		1851.25	25 (low)	1.2702	Plot 5.2 - 40
		1880	600 (mid)	1.2770	Plot 5.2 - 41
		1908.75	1175 (high)	1.2715	Plot 5.2 - 42
	Rev A RETAP Payload size = 4096	824.7	1013 (low)	1.2769	Plot 5.2 - 43
		836.52	384 (mid)	1.2736	Plot 5.2 - 44
		848.31	777 (high)	1.2724	Plot 5.2 - 45
		1851.25	25 (low)	1.2738	Plot 5.2 - 46
		1880	600 (mid)	1.2719	Plot 5.2 - 47
		1908.75	1175 (high)	1.2744	Plot 5.2 - 48

5.2.1 GSM Occupied Bandwidth Plots

Plot 5.2 -1 (Ch128, GSM GMSK)

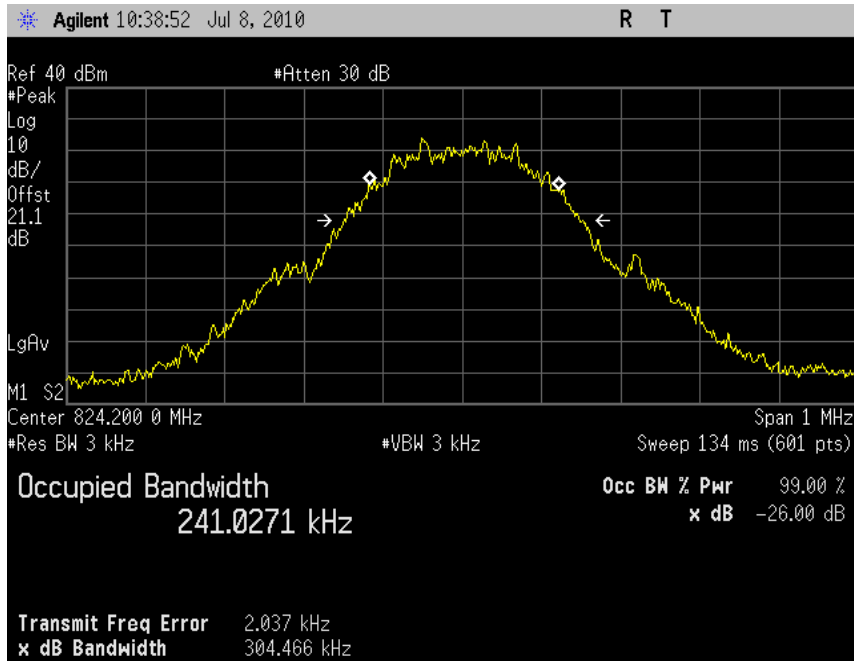

Plot 5.2-2 (Ch. 190, GSM GMSK)

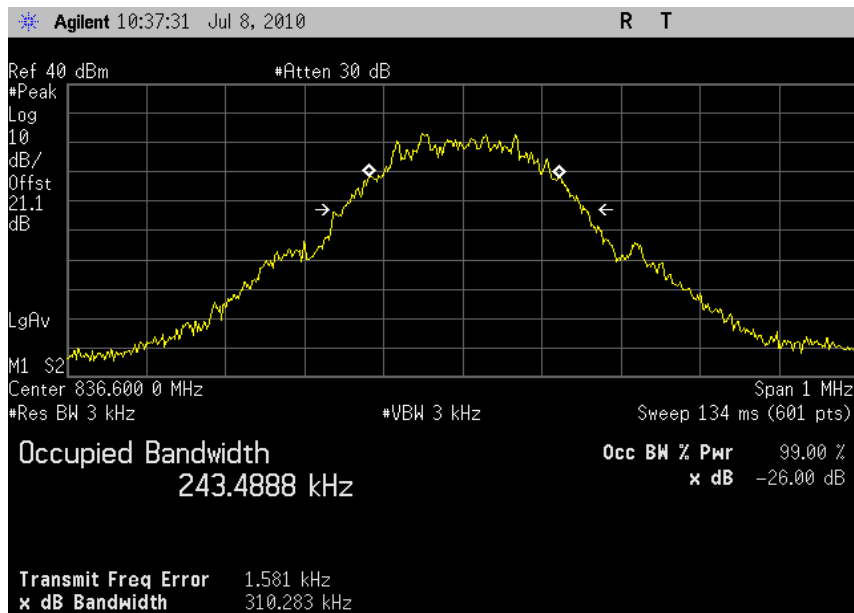

Plot 5.2-3 (Ch. 251, GSM GMSK)

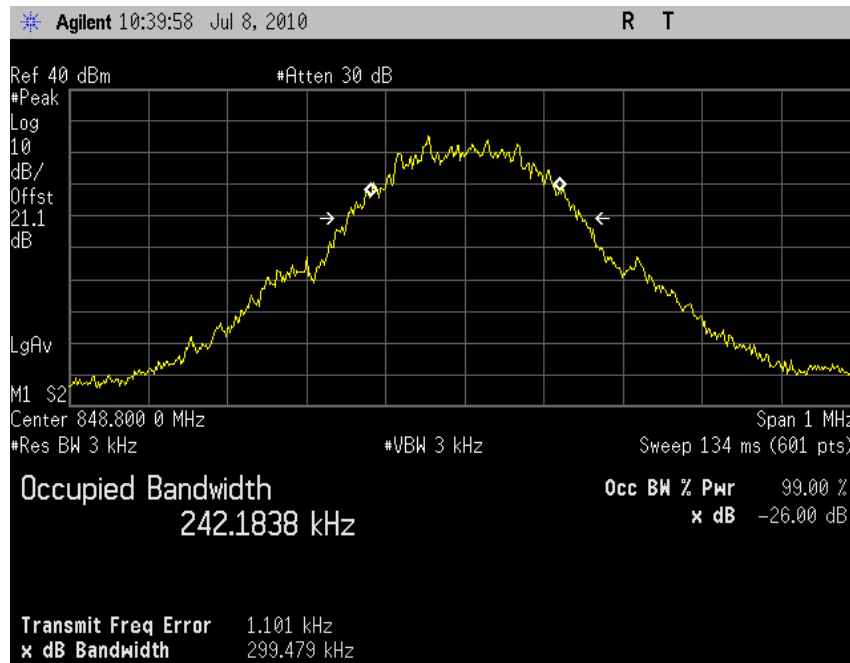

Plot 5.2-4 (Ch. 512, GSM GMSK)

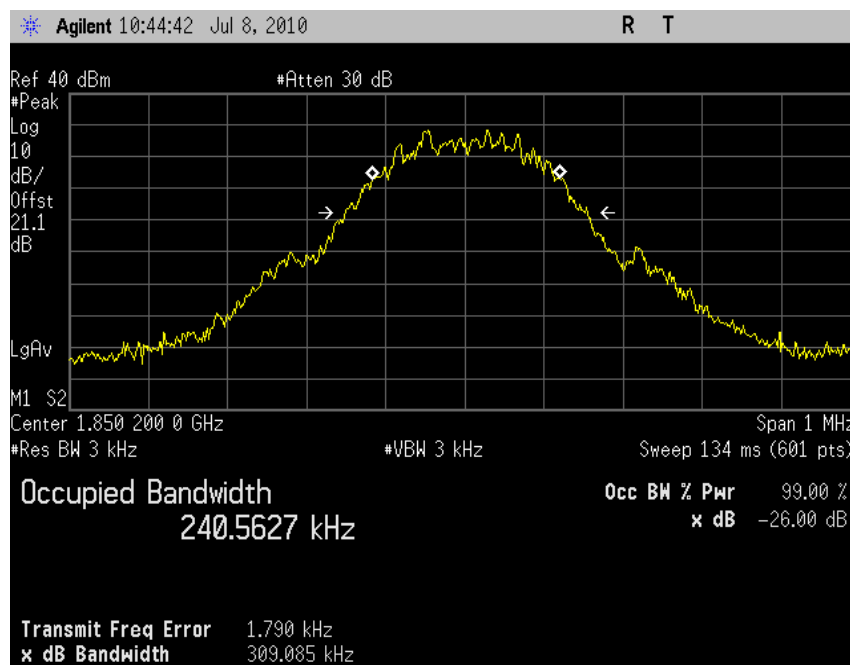

Plot 5.2-5 (Ch. 661, GSM GMSK)

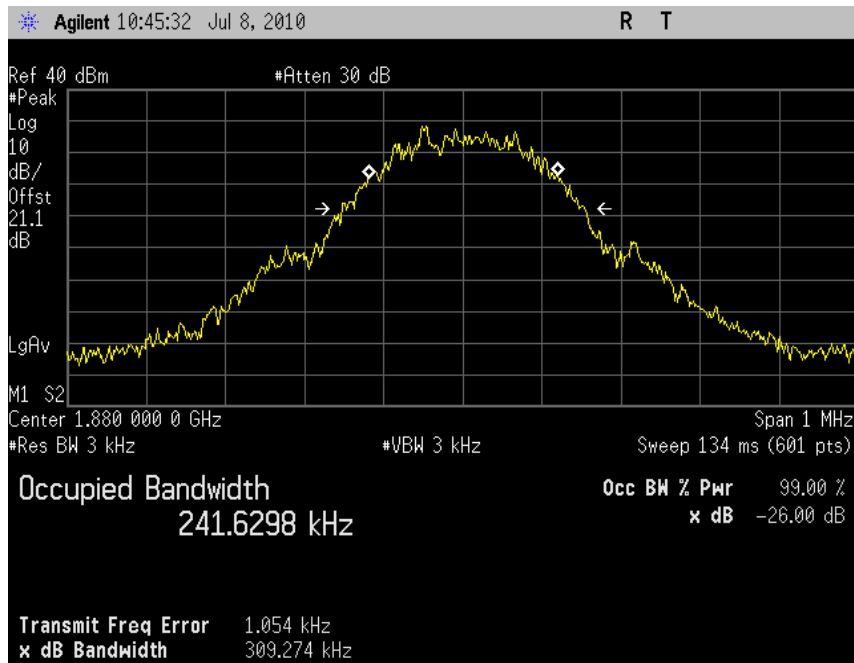

Plot 5.2-6 (Ch. 810, GSM GMSK)

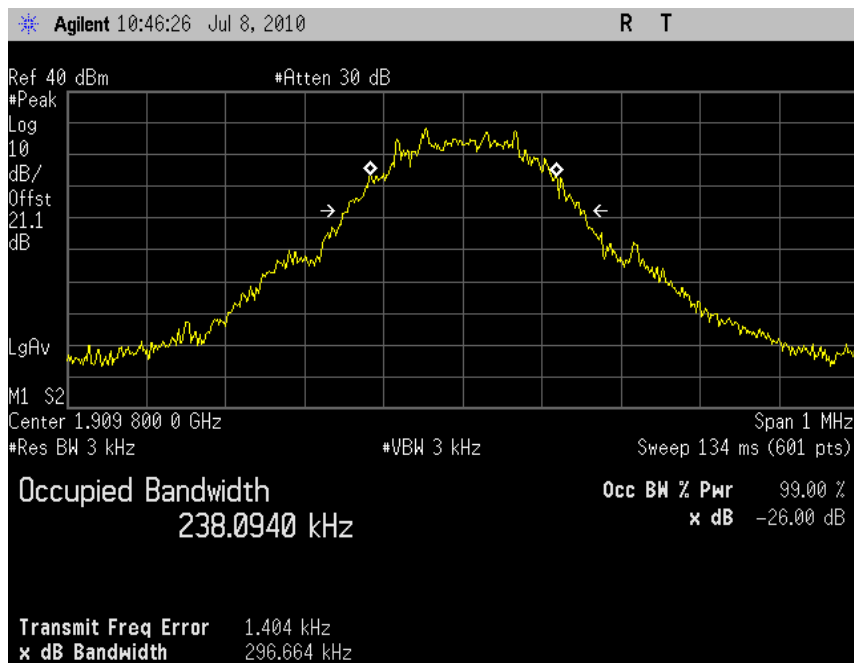

Plot 5.2-7 (Ch. 128, GSM 8PSK)

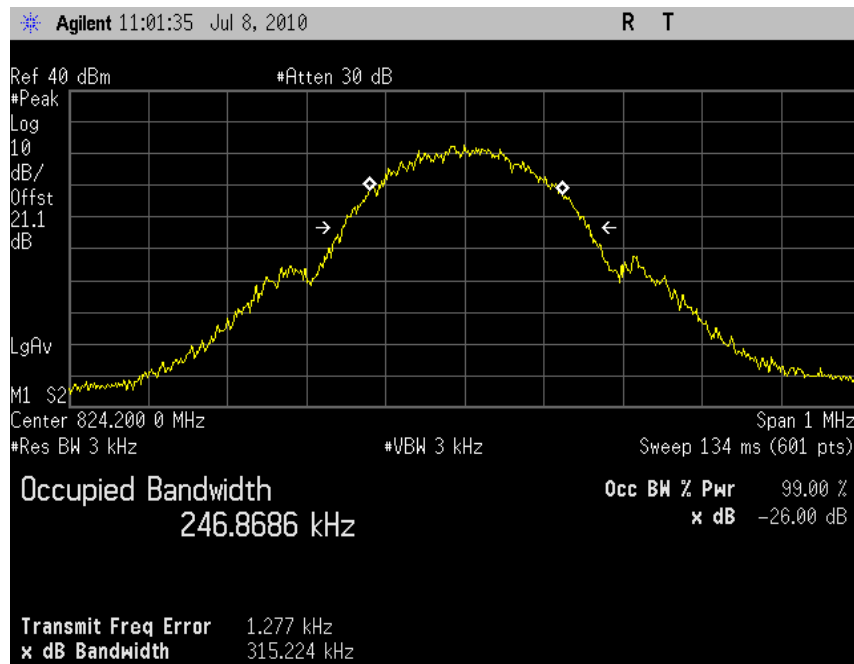

Plot 5.2-8 (Ch. 190, GSM 8PSK)

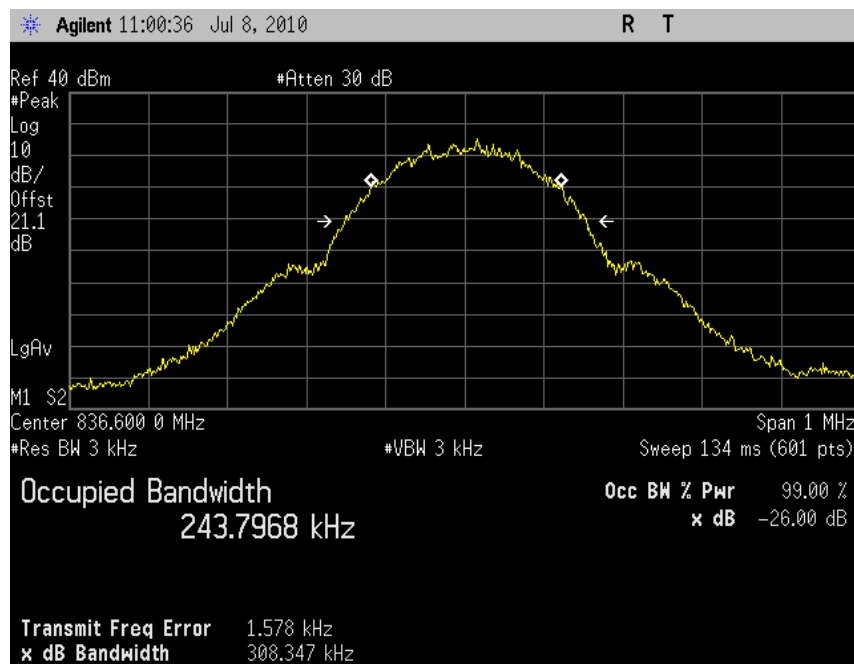

Plot 5.2-9 (Ch. 251, GSM 8PSK)

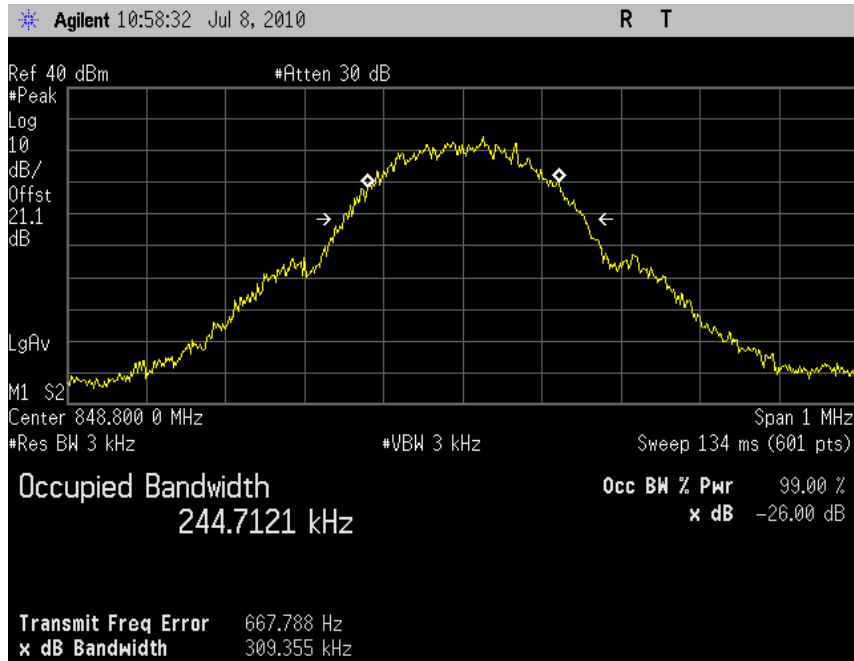

Plot 5.2-10 (Ch. 512, GSM 8PSK)

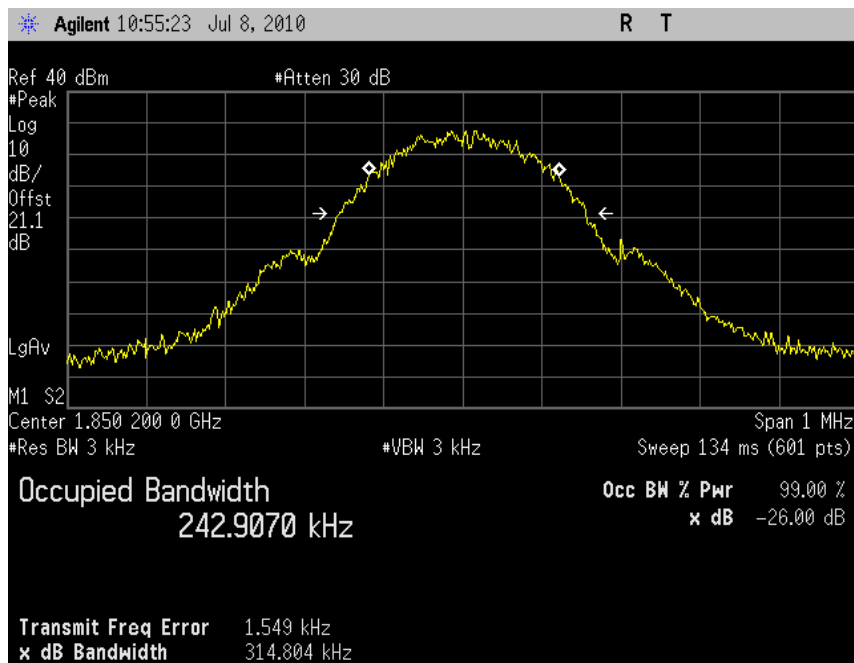

Plot 5.2-11 (Ch. 661, GSM 8PSK)

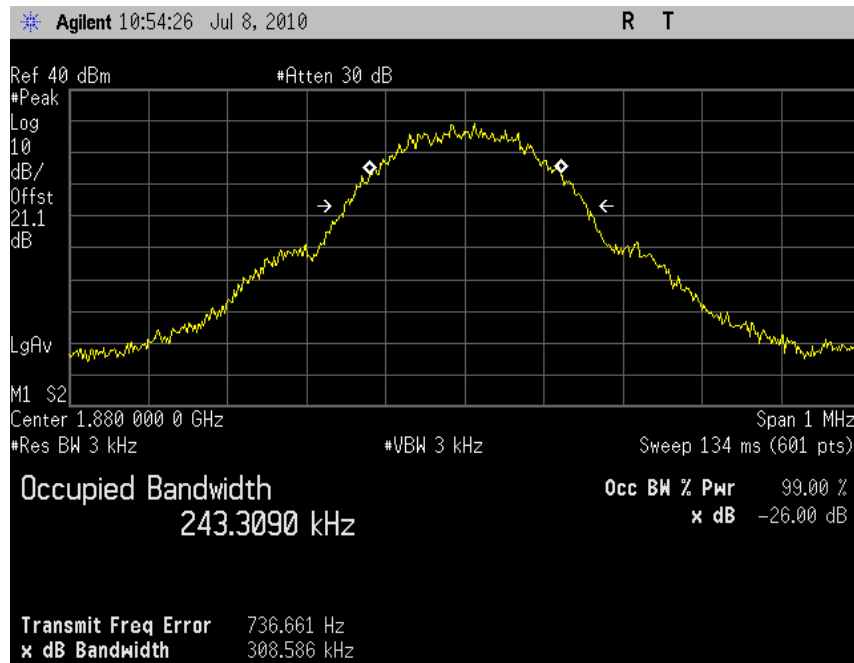

Plot 5.2-12 (Ch. 810, GSM 8PSK)

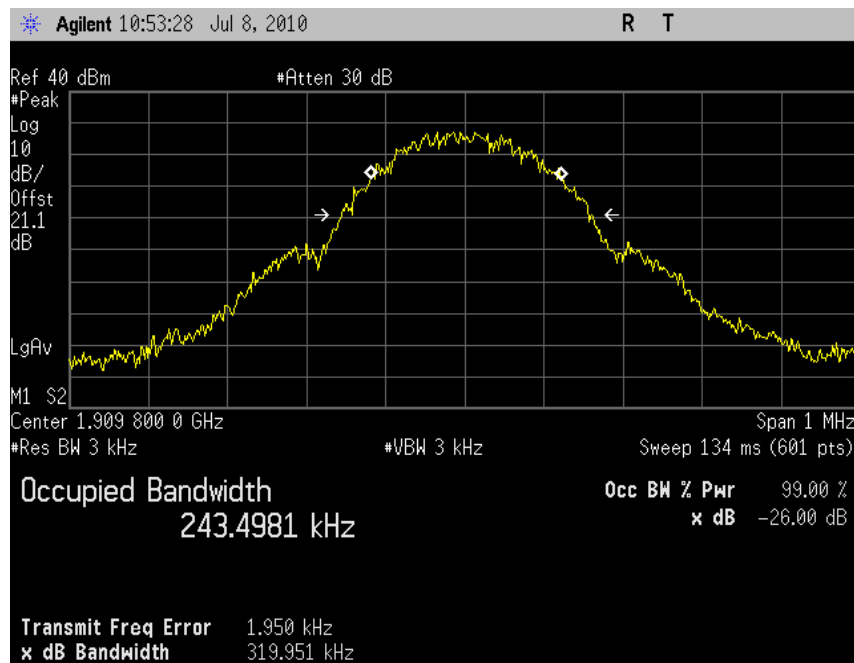

5.2.2 UMTS Occupied Bandwidth Plots

Plot 5.2-13 (Ch. 1312, Rel 99)

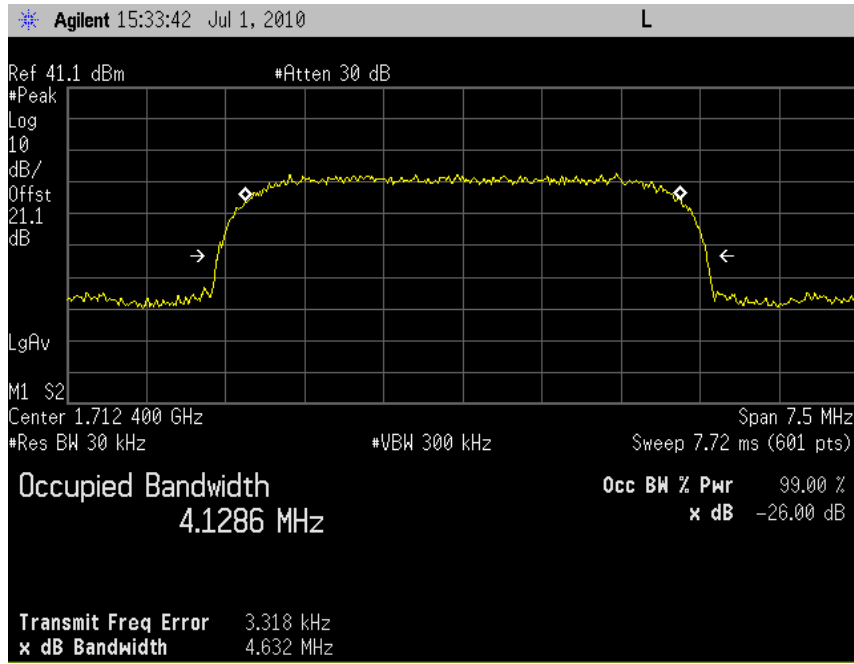

Plot 5.2-14 (Ch. 1427, Rel 99)

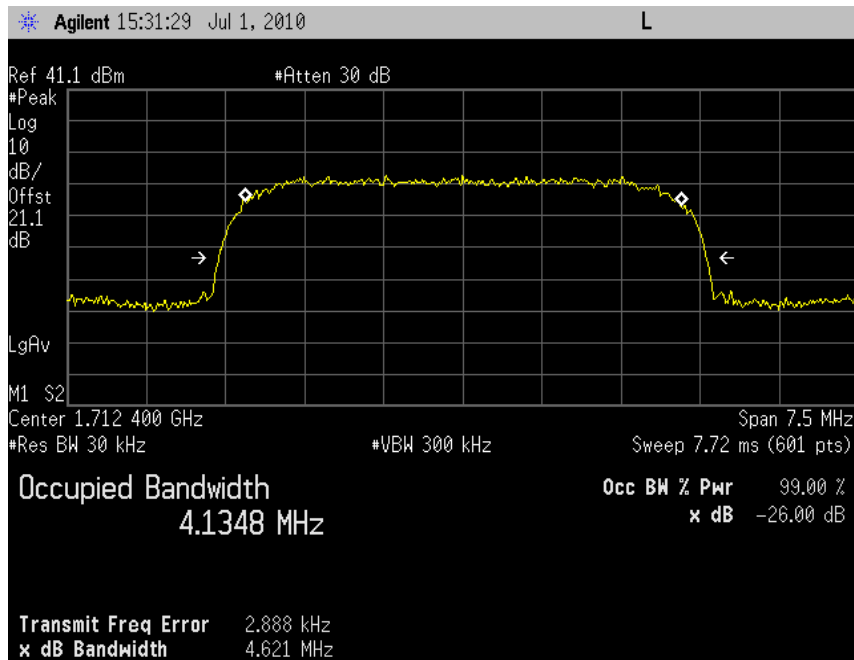

Plot 5.2-15 (Ch. 1513, Rel 99)

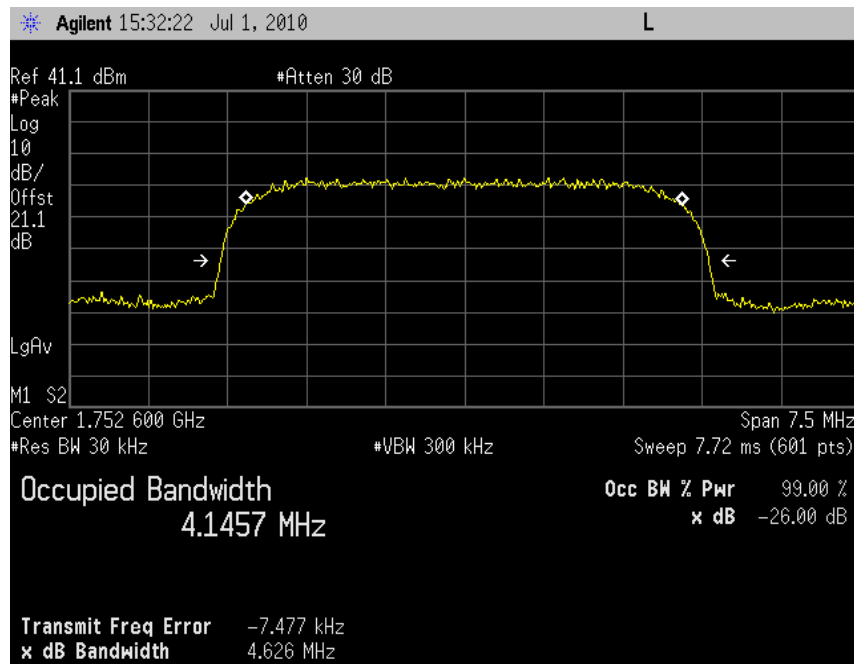

Plot 5.2-16 (Ch. 4132, Rel 99)

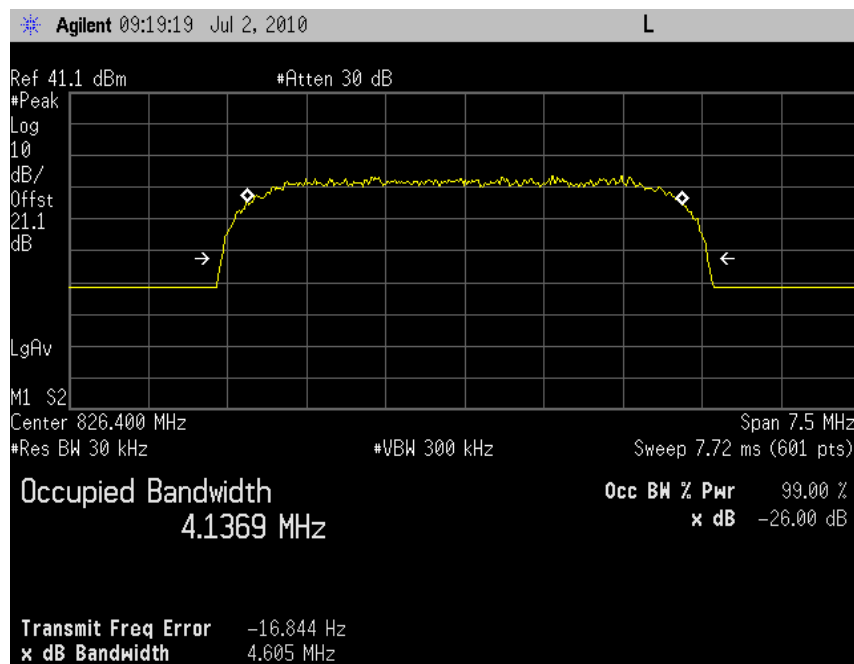

Plot 5.2-17 (Ch. 4182, Rel 99)

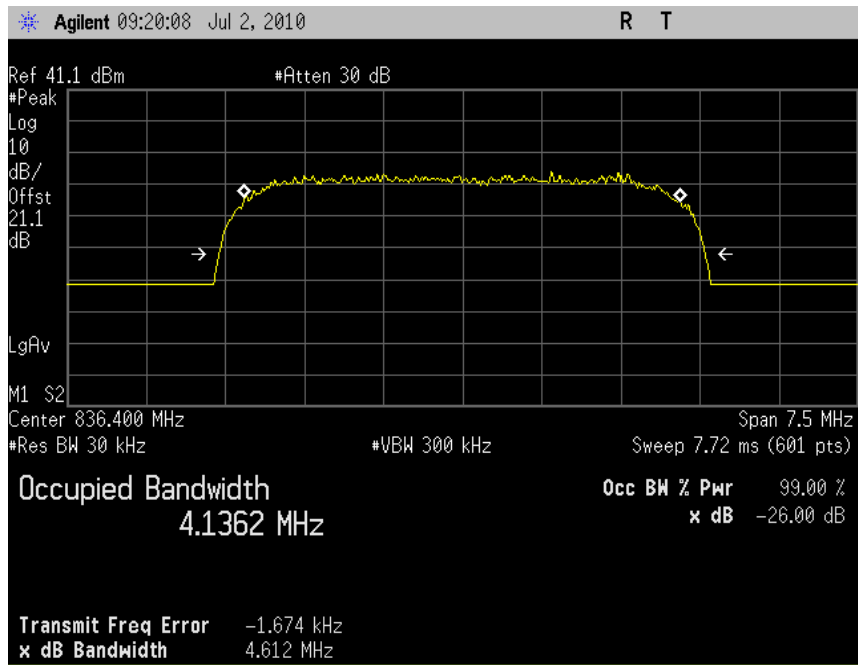

Plot 5.2-18 (Ch. 4233, Rel 99)

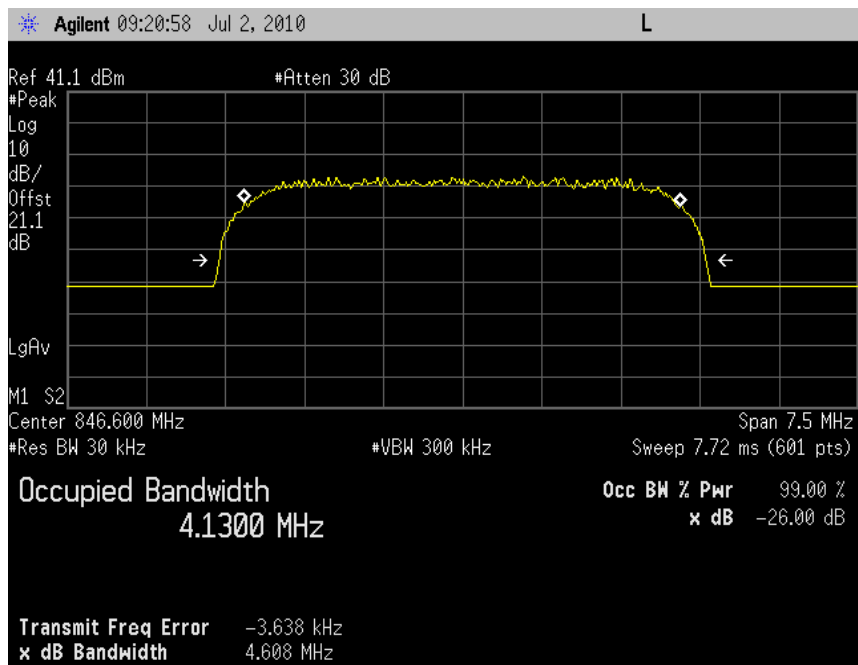

Plot 5.2-19 (Ch. 9262, Rel 99)

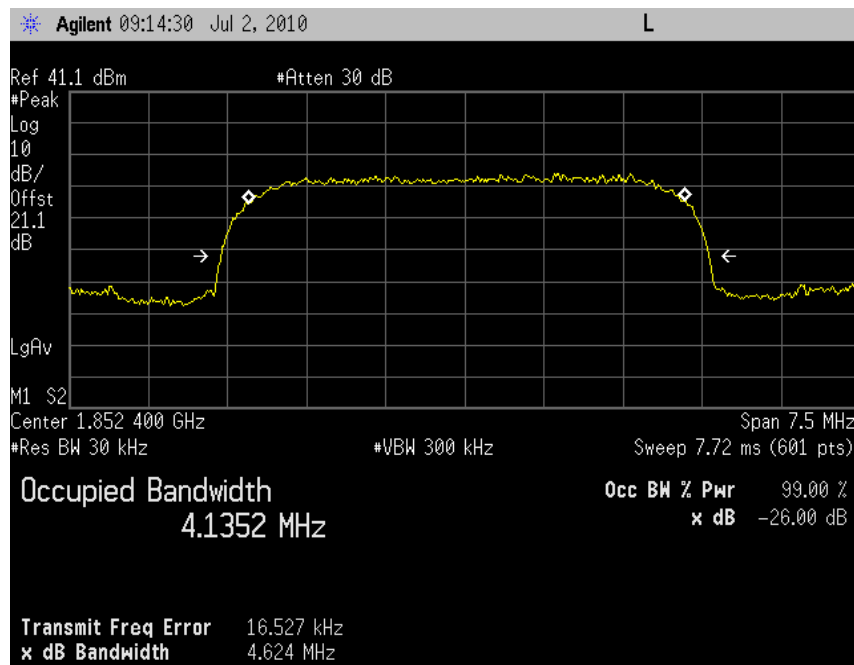

Plot 5.2-20 (Ch. 9400, Rel 99)

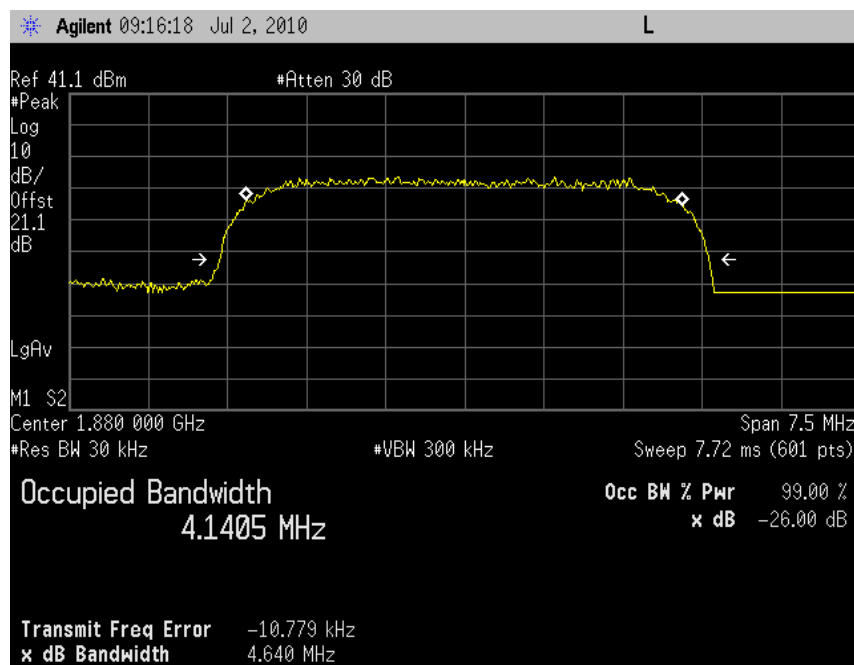

Plot 5.2-21 (Ch. 9538, Rel 99)

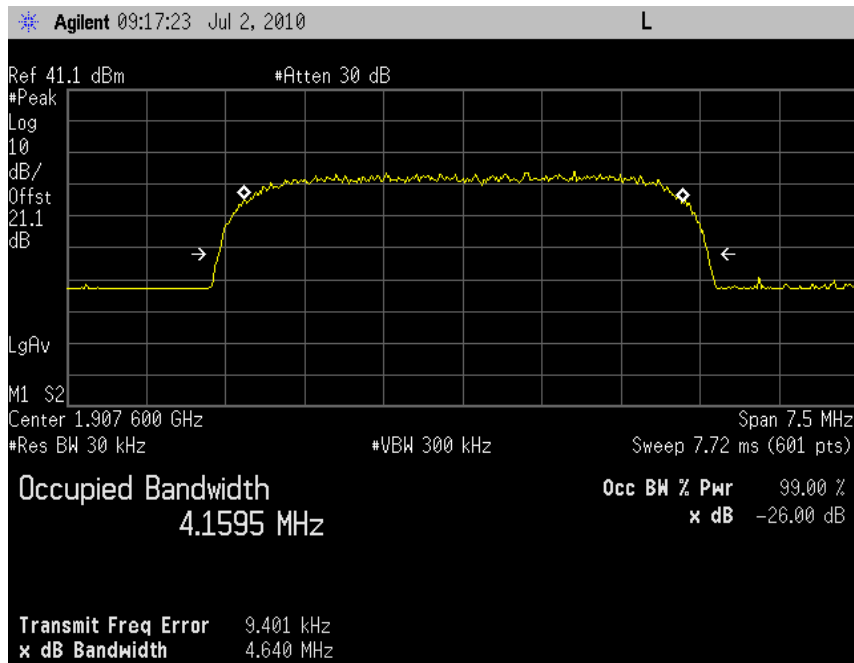

Plot 5.2-22 (Ch. 1312, HSUPA Subtest 5)

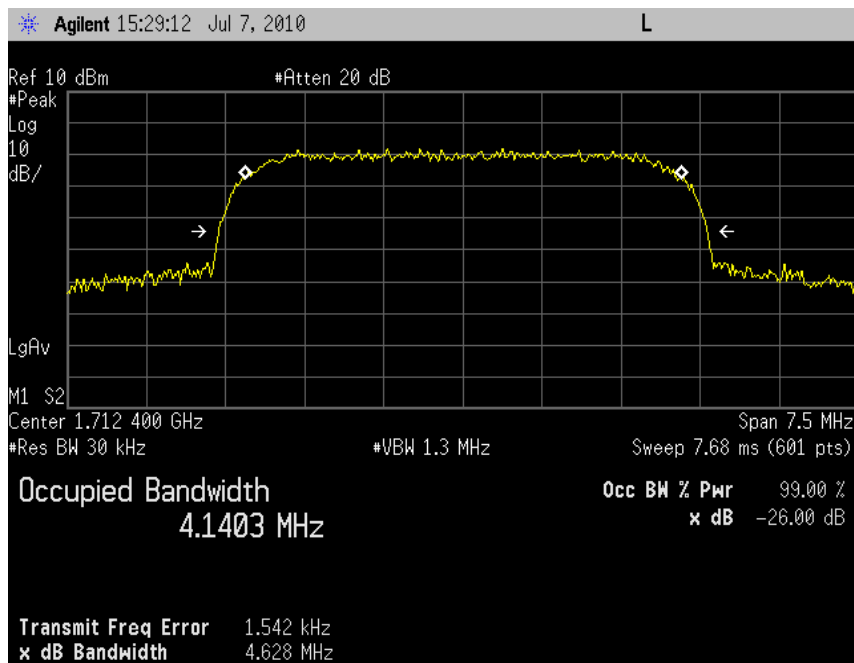

Plot 5.2-23 (Ch. 1427, HSUPA Subtest 5)

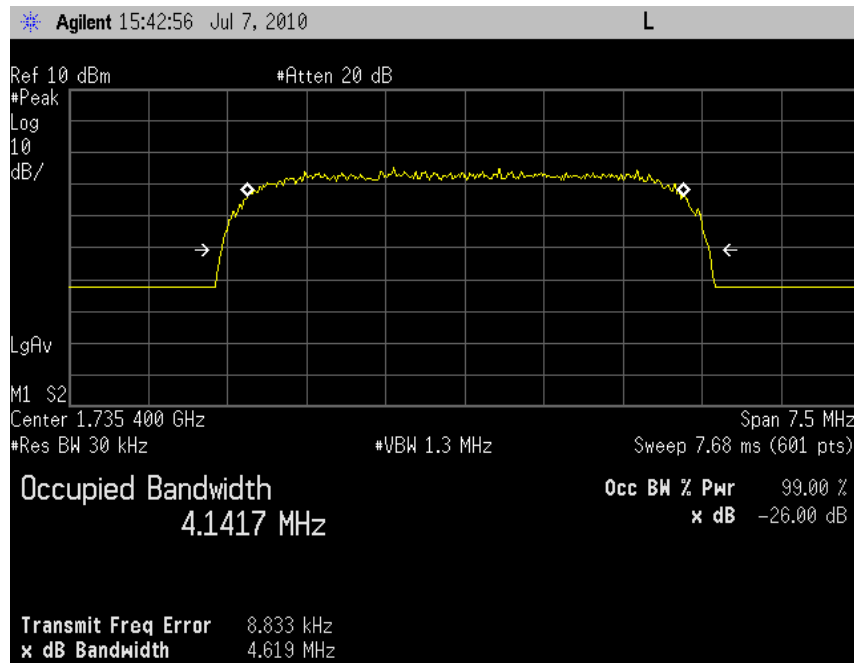

Plot 5.2-24 (Ch. 1513, HSUPA Subtest 5)

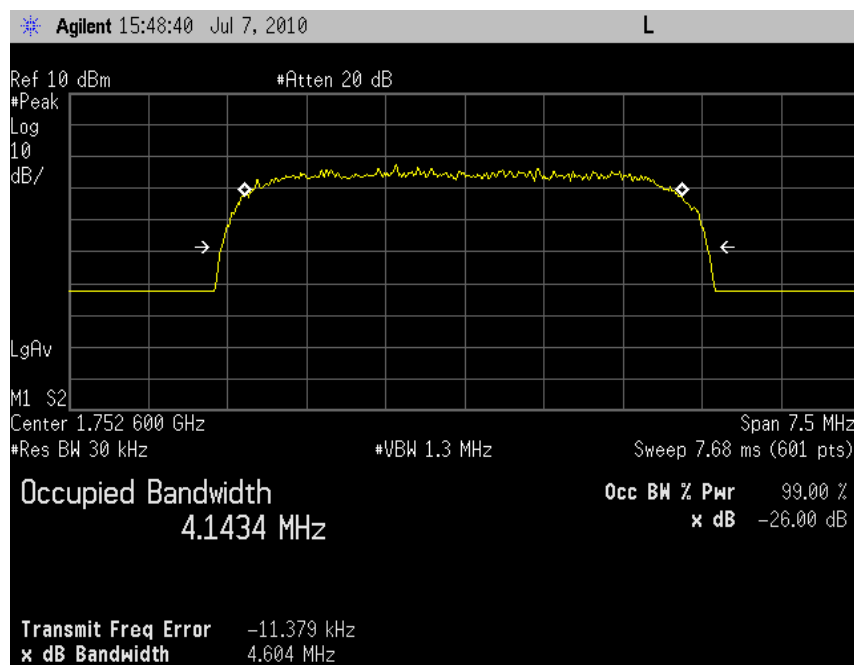

Plot 5.2-25 (Ch. 4132, HSUPA Subtest 5)

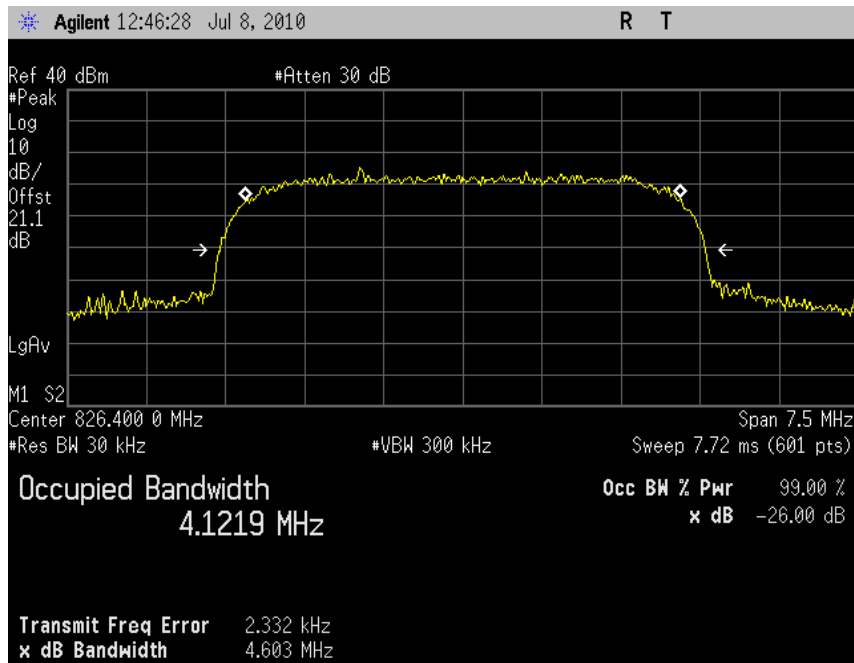

Plot 5.2-26 (Ch. 4182, HSUPA Subtest 5)

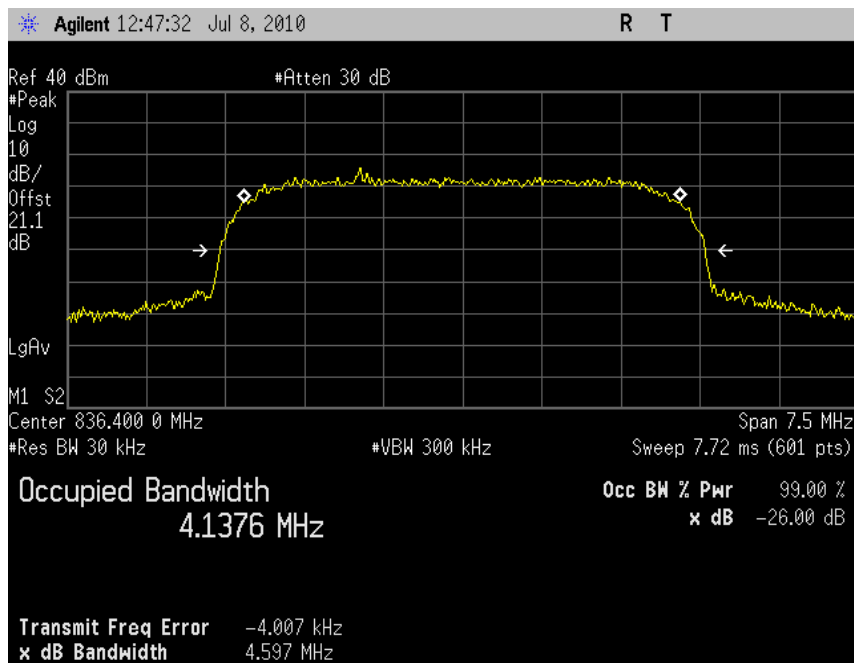

Plot 5.2-27 (Ch. 4233, HSUPA Subtest 5)

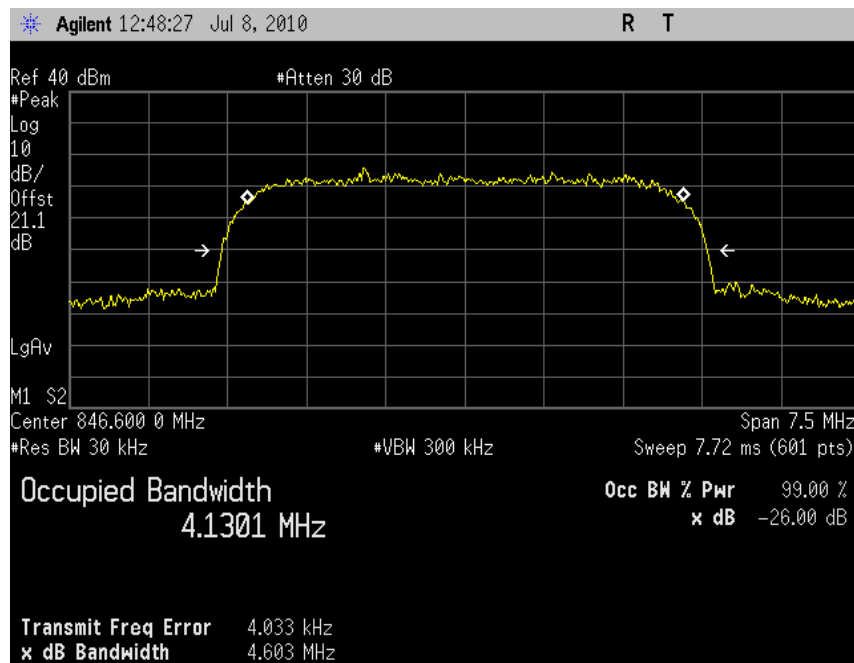

Plot 5.2-28 (Ch. 9262, HSUPA Subtest 5)

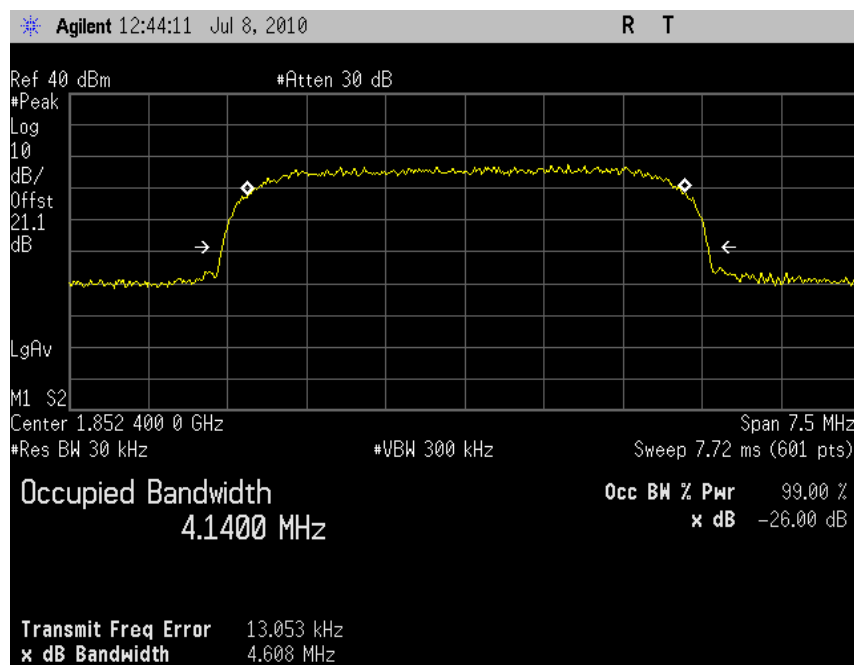

Plot 5.2-29 (Ch. 9400, HSUPA Subtest 5)

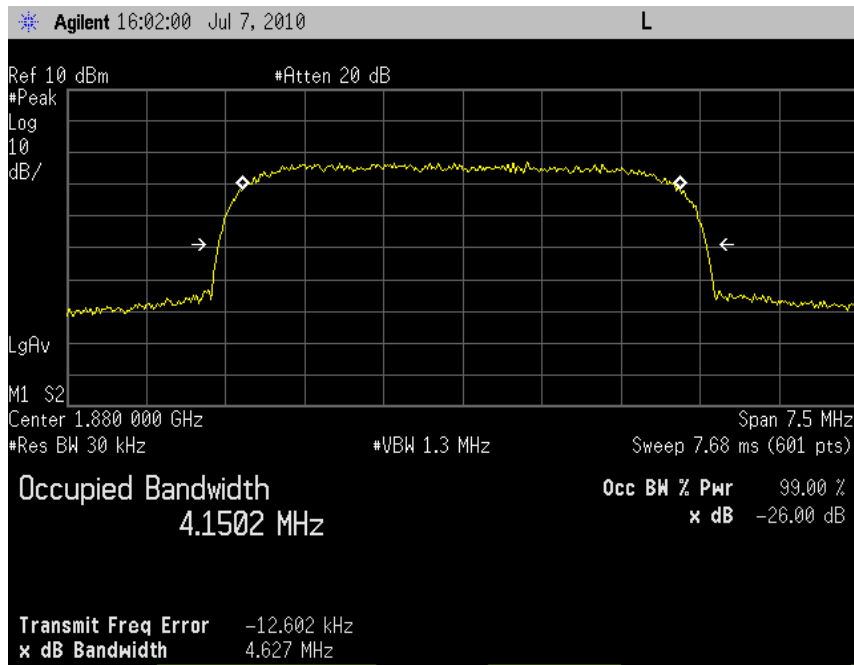

Plot 5.2-30 (Ch. 9538, HSUPA Subtest 5)

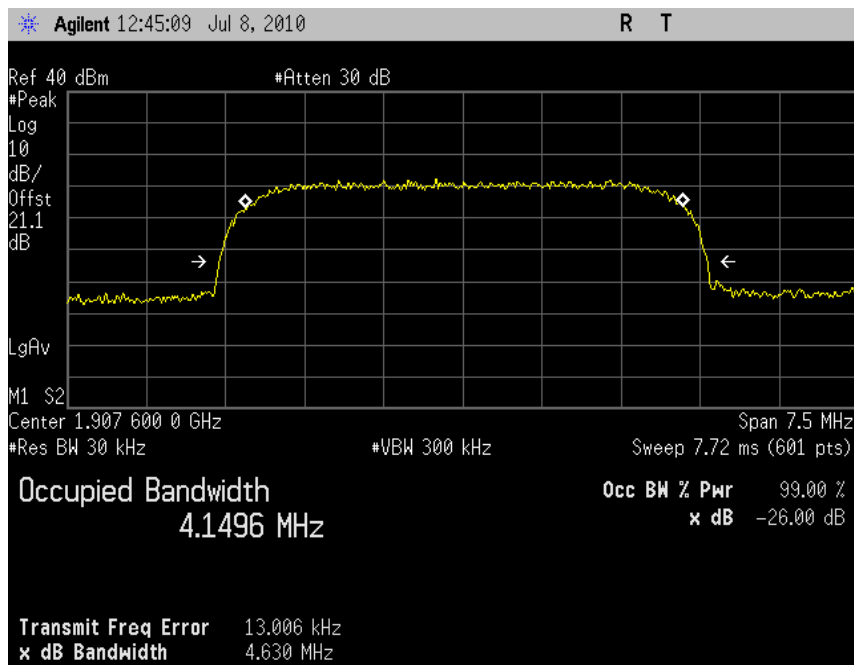

5.2.3 CDMA2000 Occupied Bandwidth Plots

Plot 5.2-31 (Ch. 1013, RC3 SO55)

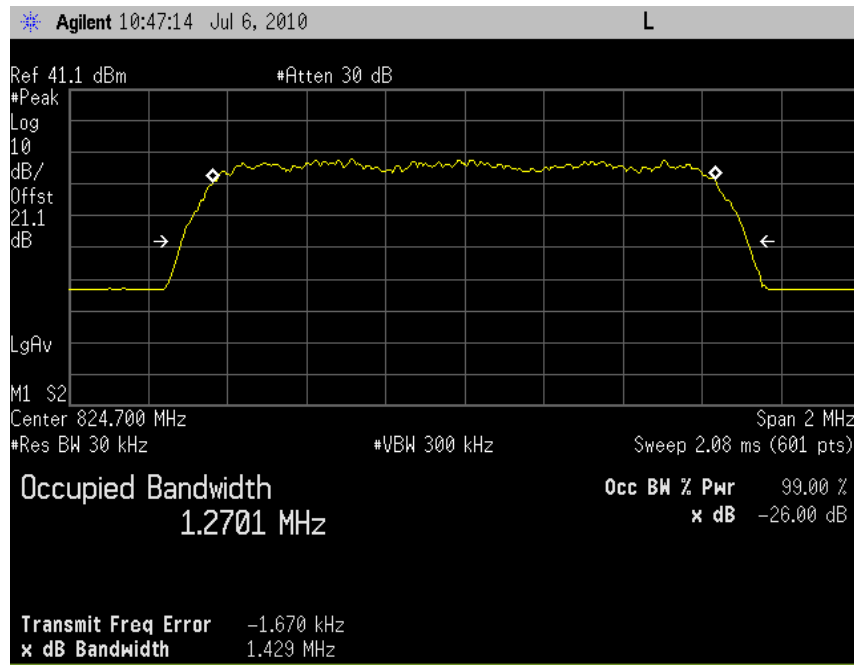

Plot 5.2-32 (Ch. 384, RC3 SO55)

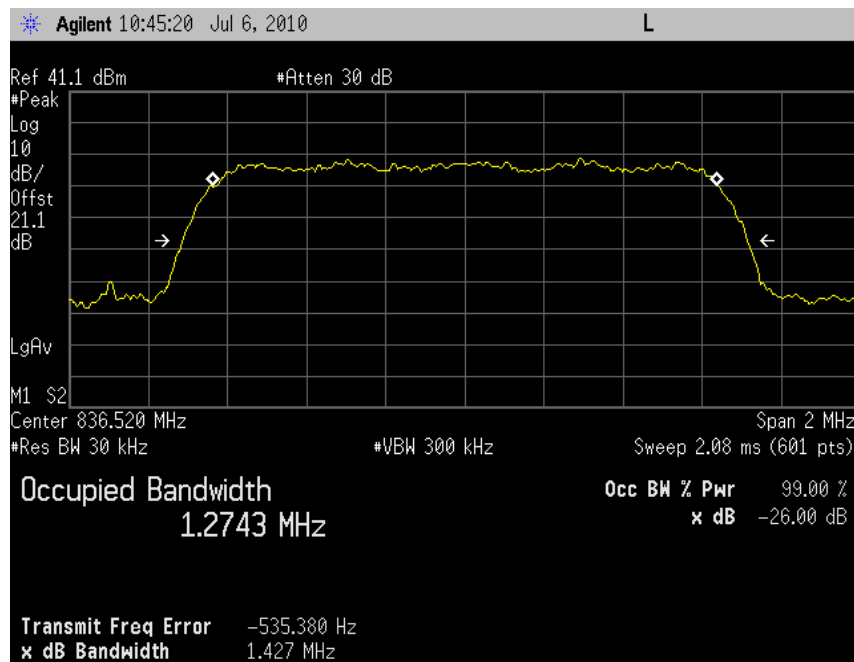

Plot 5.2-33 (Ch. 777, RC3 SO55)

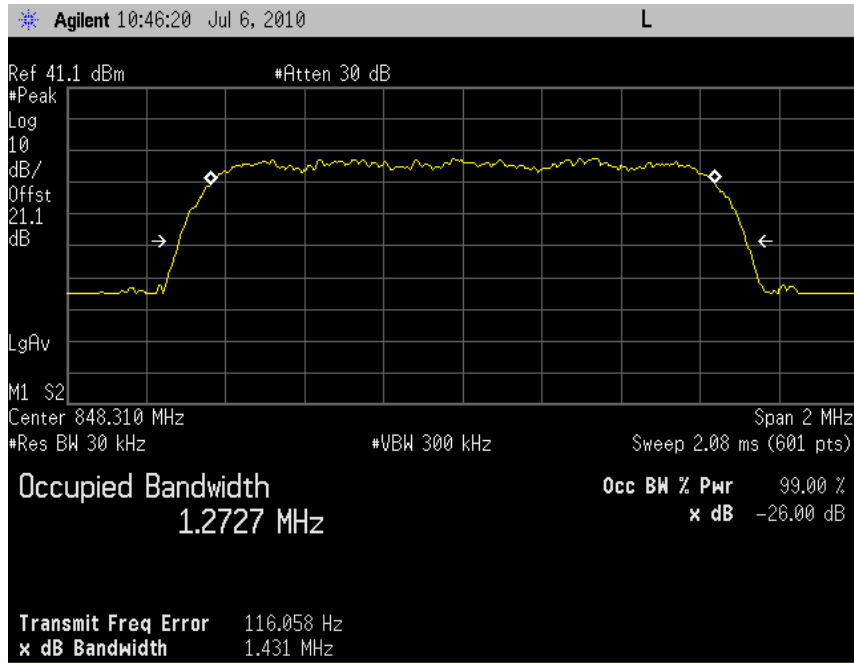

Plot 5.2-34 (Ch. 25, RC3 SO55)

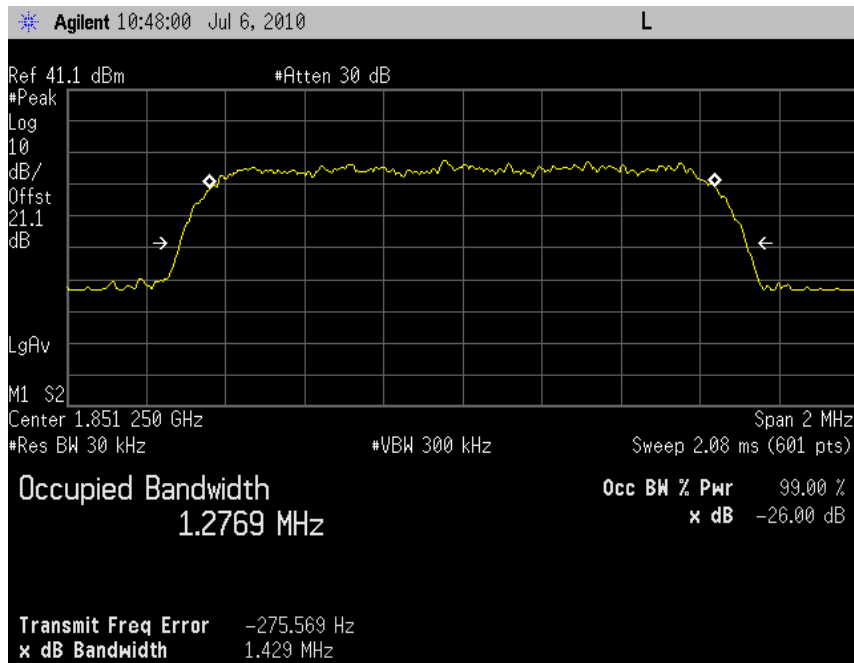

Plot 5.2-35 (Ch. 600, RC3 SO55)

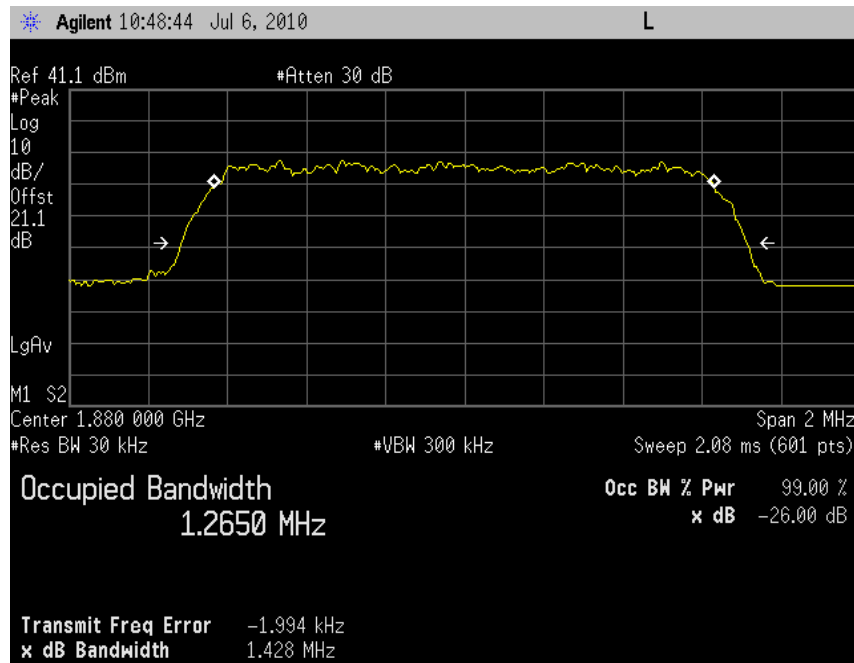

Plot 5.2-36 (Ch. 1175, RC3 SO55)

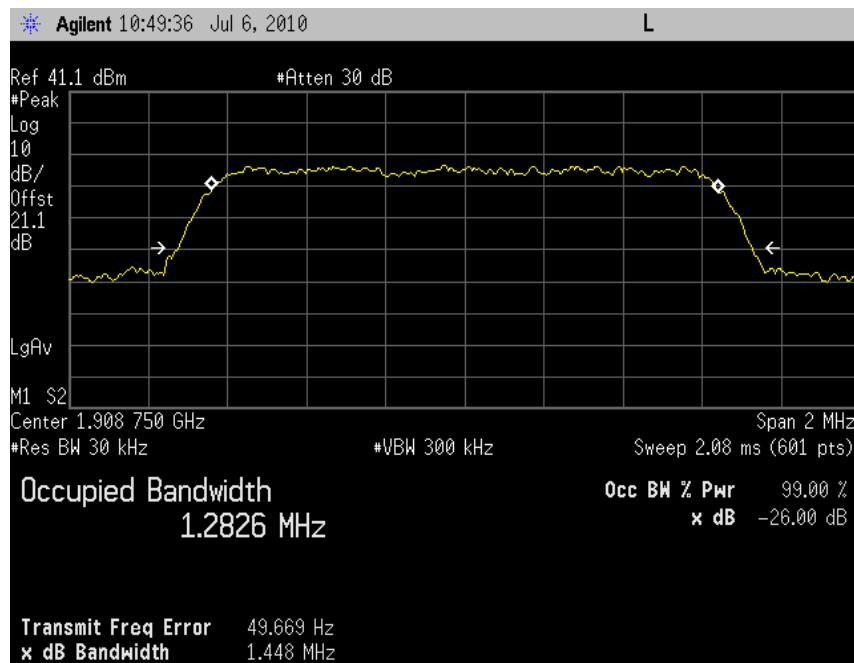

Plot 5.2-37 (Ch. 1013, Rel 0, 153.6 kbps)

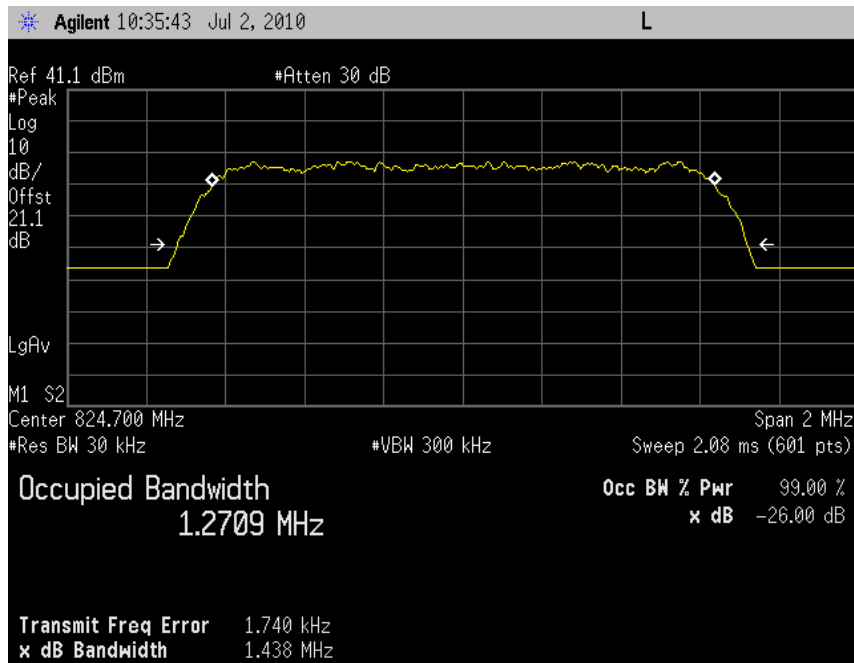

Plot 5.2-38 (Ch. 384, Rel 0, 153.6 kbps)

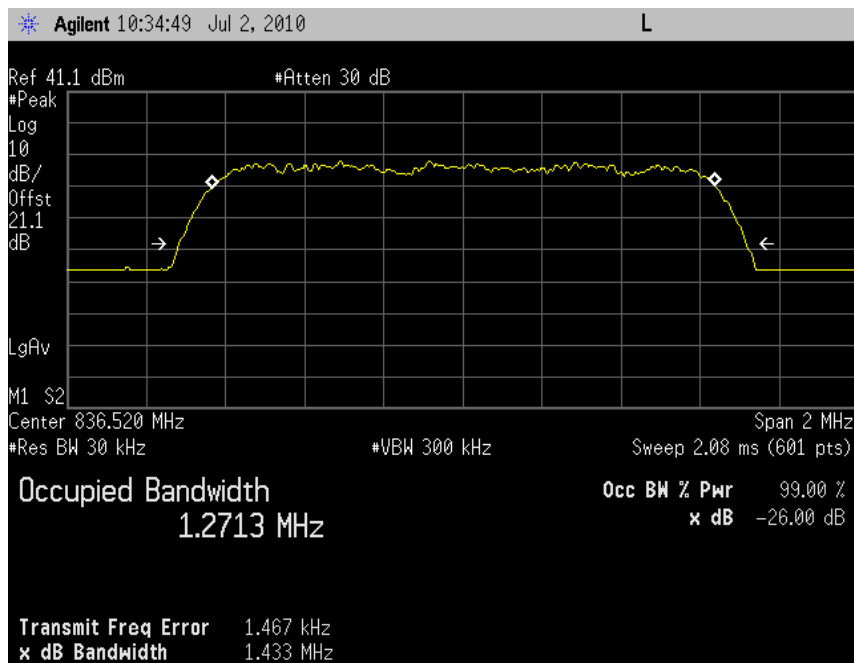

Plot 5.2-39 (Ch. 777, Rel 0, 153.6 kbps)

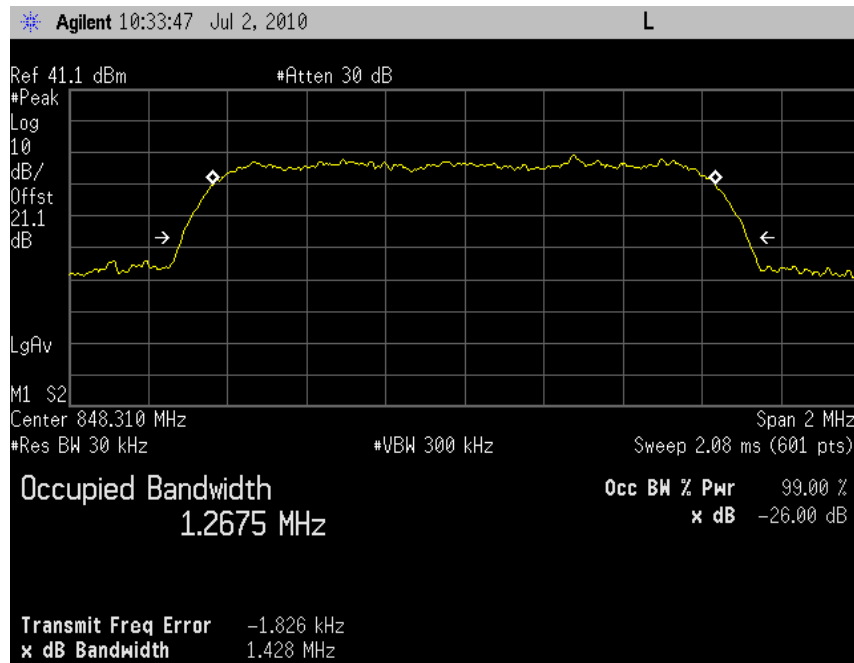

Plot 5.2-40 (Ch. 25, Rel 0, 153.6 kbps)

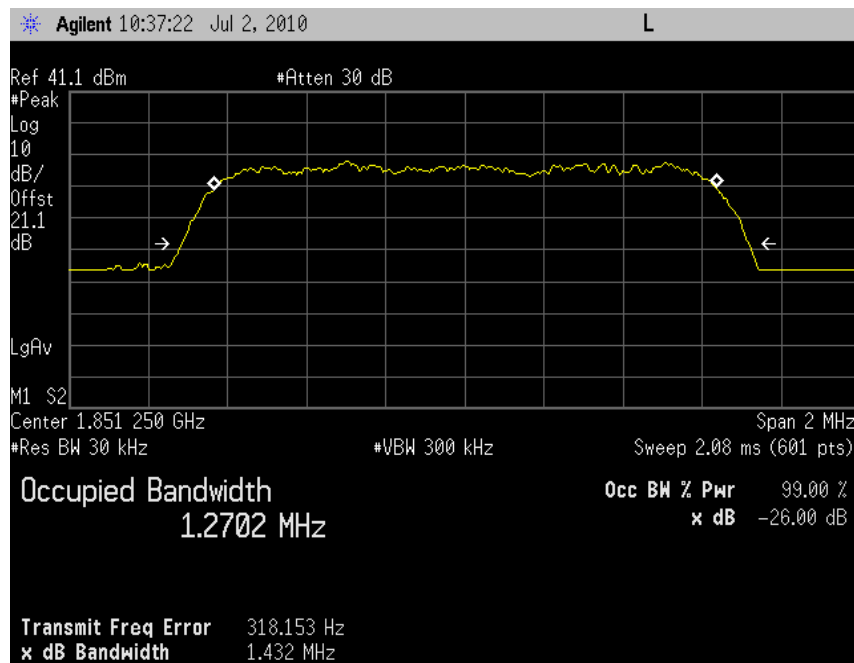

Plot 5.2-41 (Ch. 600, Rel 0, 153.6 kbps)

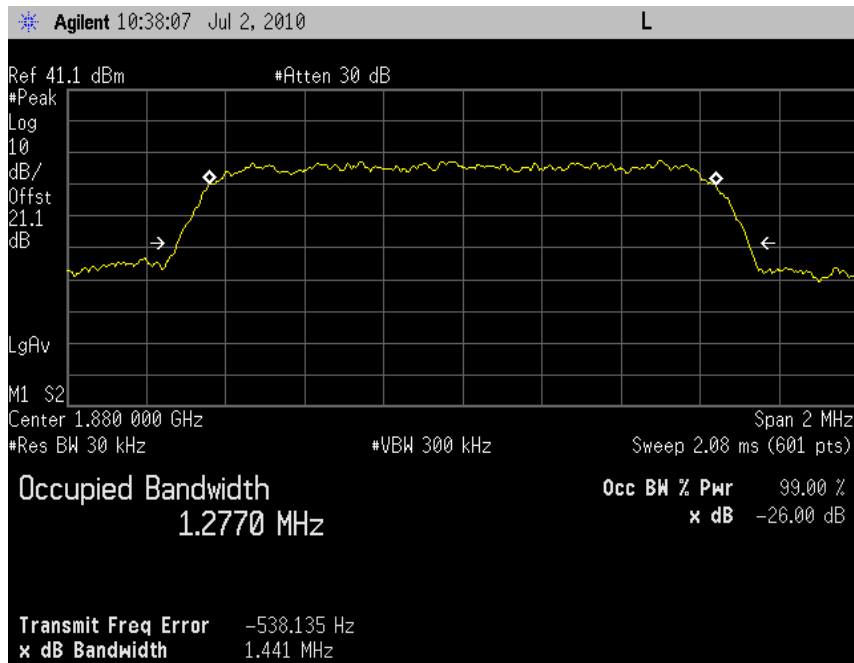

Plot 5.2-42 (Ch. 1175, Rel 0, 153.6 kbps)

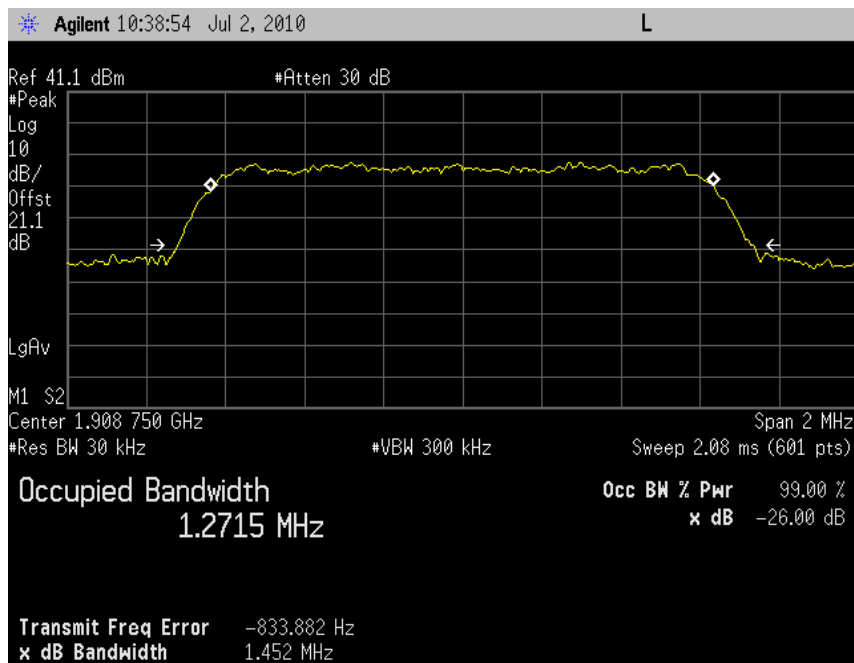

Plot 5.2-43 (Ch. 1013, Rev A, 4096 payload size)

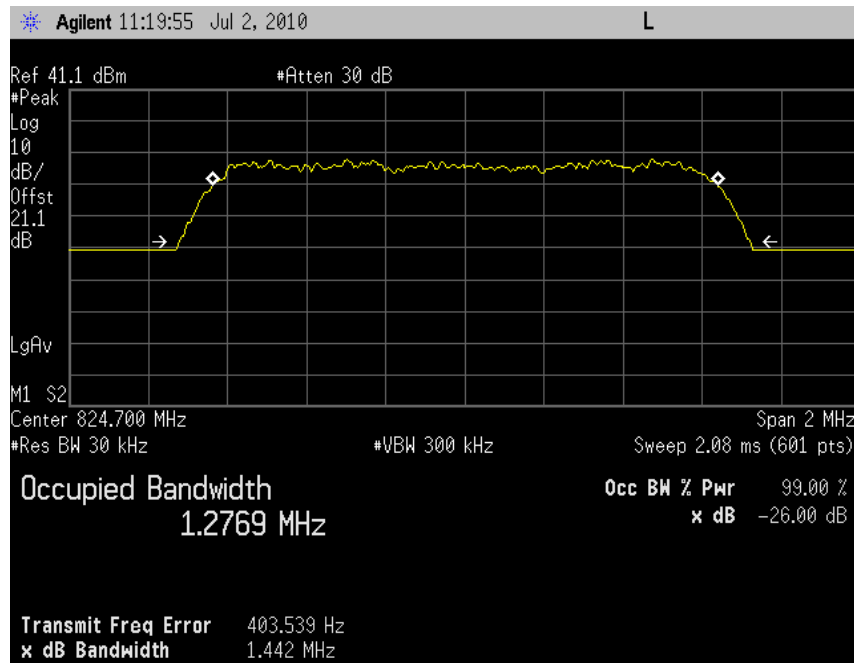

Plot 5.2-44 (Ch. 384, Rev A, 4096 payload size)

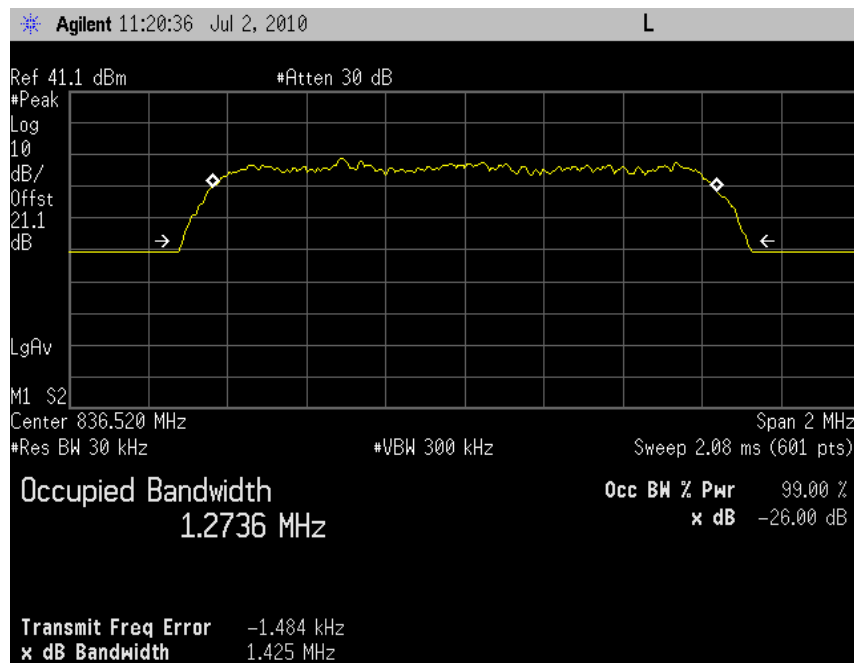

Plot 5.2-45 (Ch. 777, Rev A, 4096 payload size)



Plot 5.2-46 (Ch. 25, Rev A, 4096 payload size)

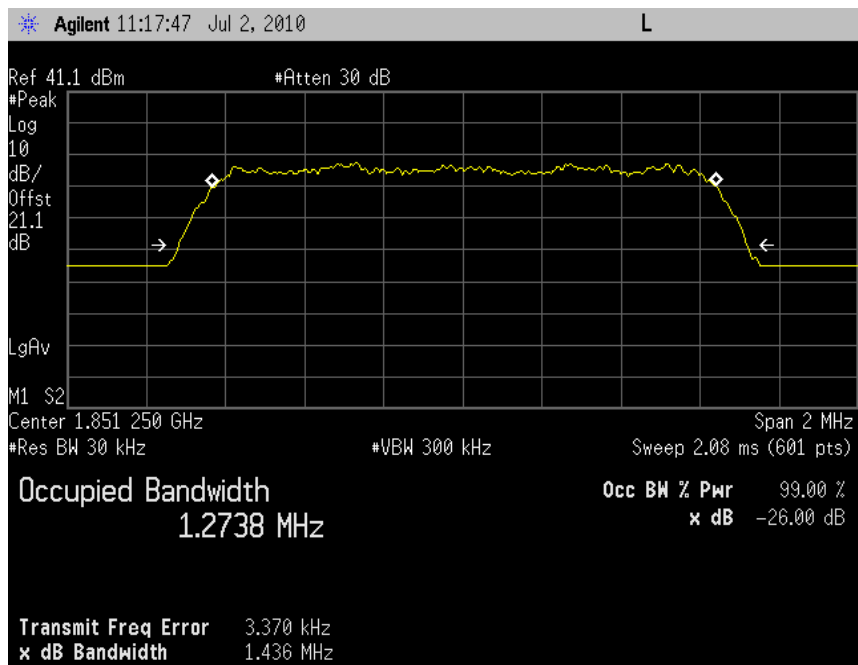

Plot 5.2-47 (Ch. 600, Rev A, 4096 payload size)

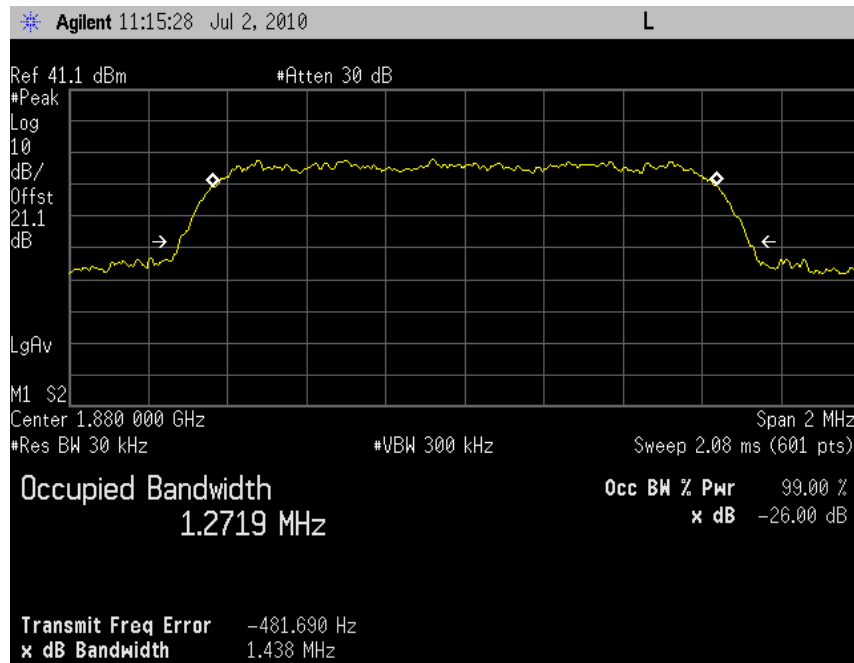

Plot 5.2-48 (Ch. 1175, Rev A, 4096 payload size)

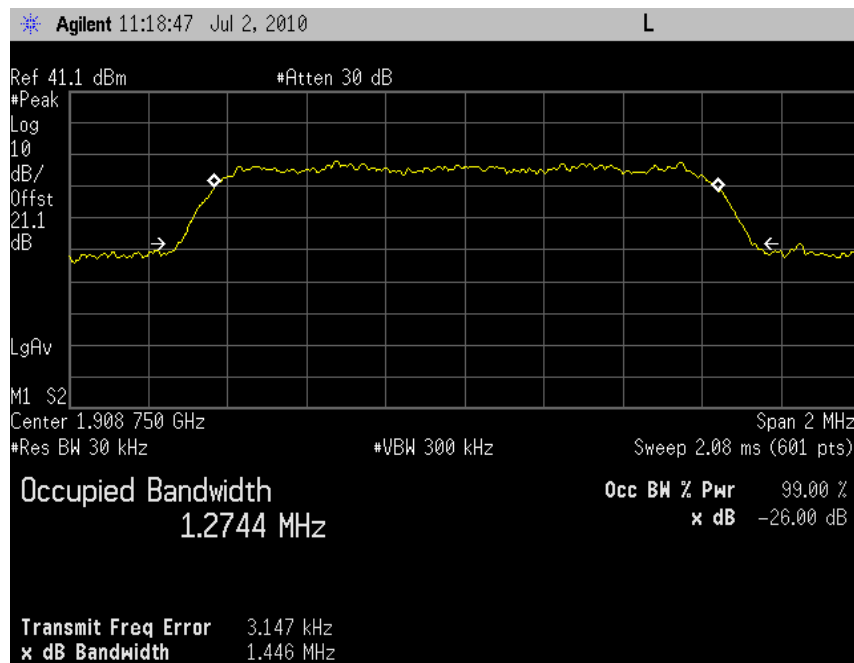

6. Band Edge Compliance

FCC:	§22.359, 24.238, 27.53(g)		
Limit:	-13dBm		
DUT SN	N10F6XTXR		
Modes Tested	CDMA 1x / 1x-EVDO	WCDMA/HSPA	GSM/GPRS/EDGE
	RC3 SO55 Rel 0, RTAP rate = 153.6kbps Rev A, RETAP payload = 4096	Rel 99 Rel 6 HSUPA, Subtest 5	GSM EDGE

Test Procedures

As shown in Figure below, connected the RF output to 8960 or 8820B, configured the UPDP-1 to operate at maximum power. The block edge emissions are measured at the required operating frequencies in each band on the spectrum analyzer.

For each block edge measurement:

- Set the spectrum analyzer span to include the block edge frequency (824, 848, 1710, 1755, 1850, 1910 MHz)
- Set a marker to point the corresponding block edge frequency in each test case
- Set display line at -13dBm
- Set resolution bandwidth to at least 1% of emission BW
- For CDMA/WCDMA measurement, set video averaging to 10 samples

The following table lists the 1% emission BW for each technology:

GMSK/8PSK	3 kHz
CDMA2000 1x/1EVDO	12.5 kHz
WCDMA/HSPA	38.5 kHz

The 8960 call box was used for CDMA 1x/1x-EVDO and UMTS measurements.

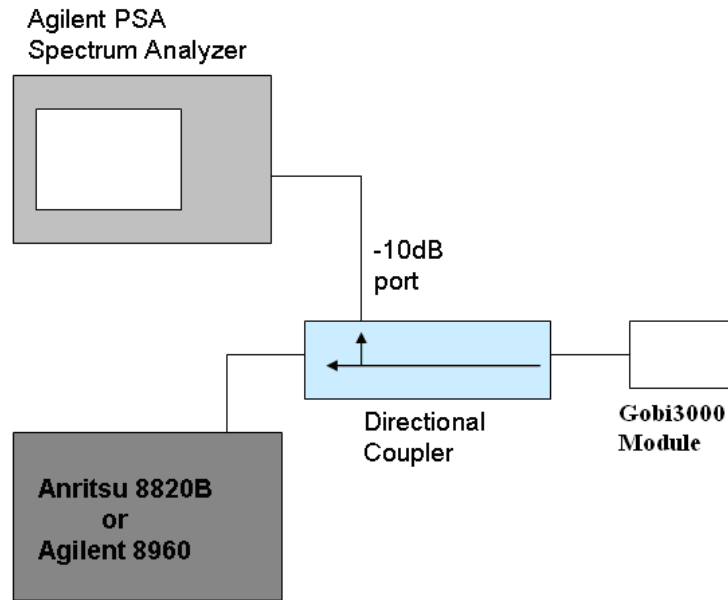

6.1 Band Edge Compliance Test Results

The test was conducted at block edges in each band.

Mode	Frequency (MHz)	Channel Tested	Corresponding Plot number	Test Result	
GSM/ GPRS/ EDGE	GMSK	824	128 (low)	Plot 6.2 - 1	Complies
		849	251 (high)	Plot 6.2 - 2	Complies
		1850	512 (low)	Plot 6.2 - 3	Complies
		1910	810 (high)	Plot 6.2 - 4	Complies
	8PSK	824	128 (low)	Plot 6.2 - 5	Complies
		849	251 (high)	Plot 6.2 - 6	Complies
		1850	512 (low)	Plot 6.2 - 7	Complies
		1910	810 (high)	Plot 6.2 - 8	Complies

Mode		Frequency (MHz)	Channel Tested	Corresponding Plot number	Test Result
WCDMA/ HSDPA/ HSUPA	Rel 99	824	4132 (low)	Plot 6.2 - 9	Complies
		849	4233 (high)	Plot 6.2 - 10	Complies
		1710	1312 (low)	Plot 6.2 - 11	Complies
		1755	1513 (high)	Plot 6.2 - 12	Complies
		1850	9262 (low)	Plot 6.2 - 13	Complies
		1910	9538 (high)	Plot 6.2 - 14	Complies
	HSUPA Rel 6 Subtest 5	824	4132 (low)	Plot 6.2 - 15	Complies
		849	4233 (high)	Plot 6.2 - 16	Complies
		1710	1312 (low)	Plot 6.2 - 17	Complies
		1755	1513 (high)	Plot 6.2 - 18	Complies
		1850	9262 (low)	Plot 6.2 - 19	Complies
		1910	9538 (high)	Plot 6.2 - 20	Complies

Mode		Frequency (MHz)	Channel Tested	Corresponding Plot number	Test Result
CDMA1x/ 1x-EVDO	RC3 SO55	824	1013 (low)	Plot 6.2 - 21	Complies
		849	777 (high)	Plot 6.2 - 22	Complies
		1850	25 (low)	Plot 6.2 - 23	Complies
		1910	1175 (high)	Plot 6.2 - 24	Complies
	Rel 0 RTAP rate = 153.6kbps	824	1013 (low)	Plot 6.2 - 25	Complies
		849	777 (high)	Plot 6.2 - 26	Complies
		1850	25 (low)	Plot 6.2 - 27	Complies
		1910	1175 (high)	Plot 6.2 - 28	Complies
	Rev A RETAP Payload size = 4096	824	1013 (low)	Plot 6.2 - 29	Complies
		849	777 (high)	Plot 6.2 - 30	Complies
		1850	25 (low)	Plot 6.2 - 31	Complies
		1910	1175 (high)	Plot 6.2 - 32	Complies

6.1.1 GSM Band Edge Plots

Plot 6.2 - 1 (Ch128, GMSK)

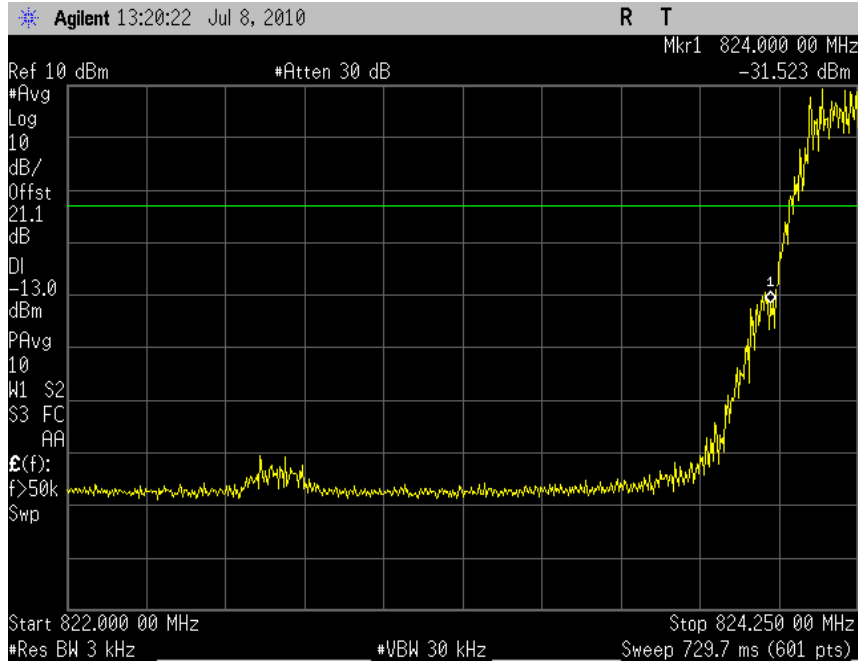

Plot 6.2 - 2 (Ch251, GMSK)

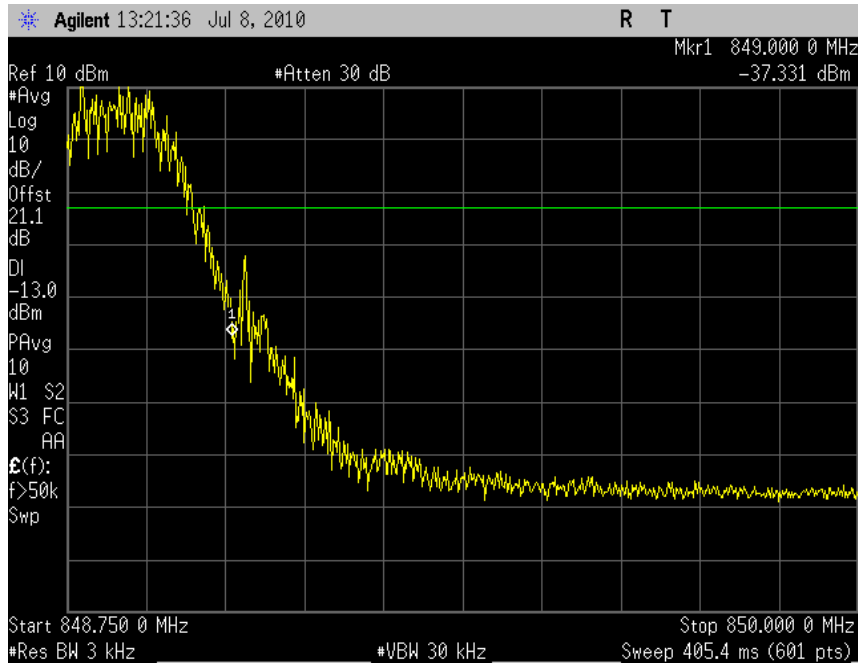

Plot 6.2 - 3 (Ch512, GMSK)

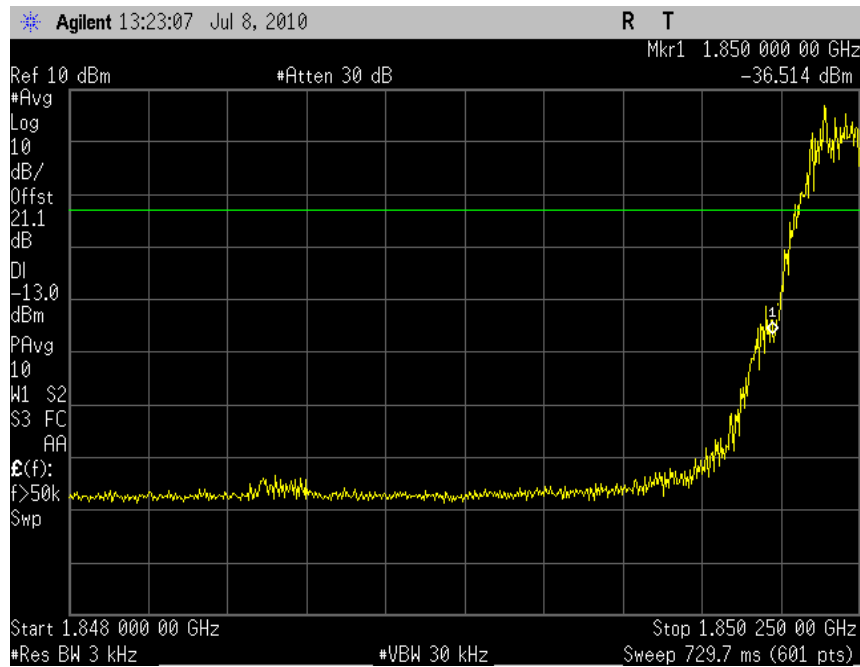

Plot 6.2 - 4 (Ch810, GMSK)

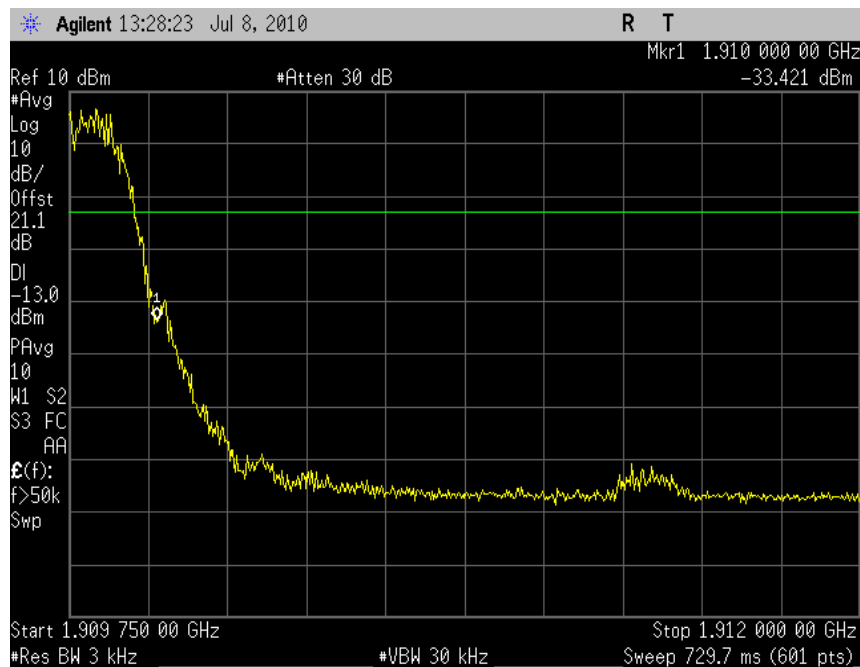

Plot 6.2 - 5 (Ch128, 8PSK)

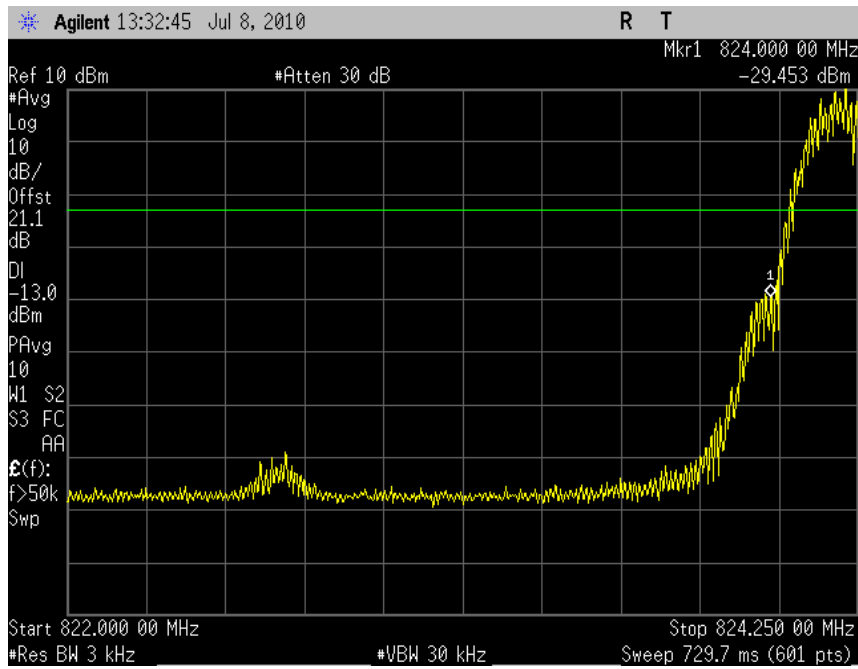

Plot 6.2 - 6 (Ch251, 8PSK)

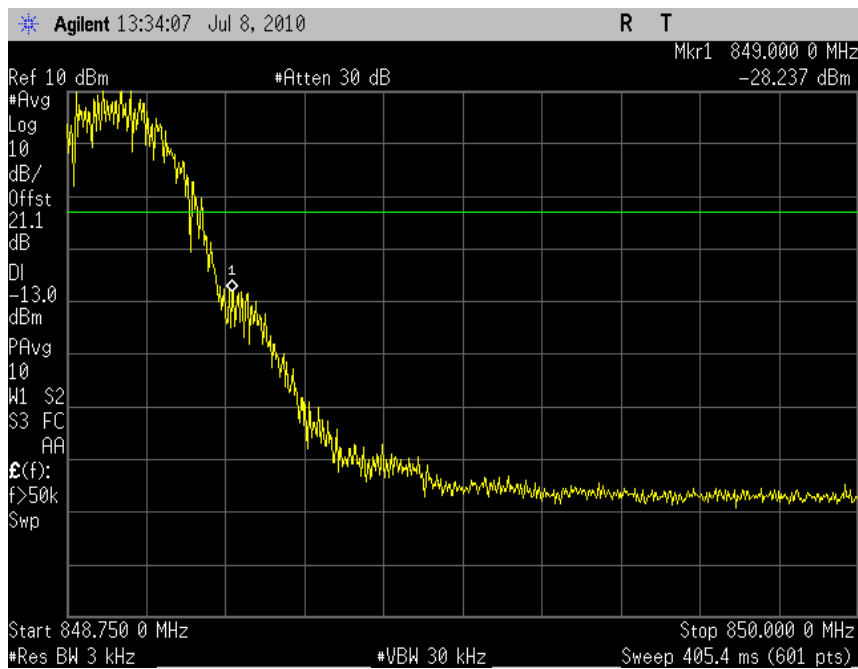

Plot 6.2 - 7 (Ch512, 8PSK)

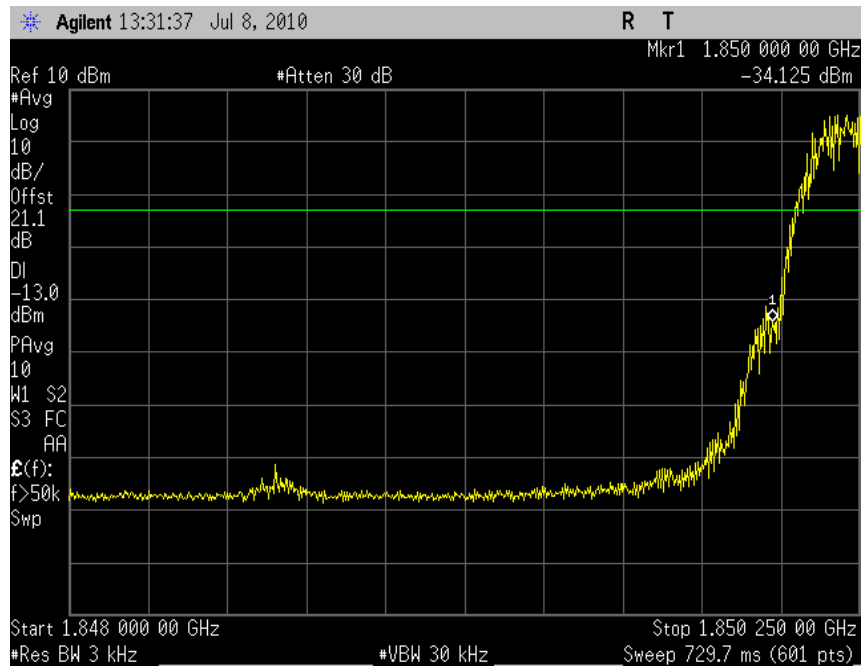

Plot 6.2 - 8 (Ch810, 8PSK)

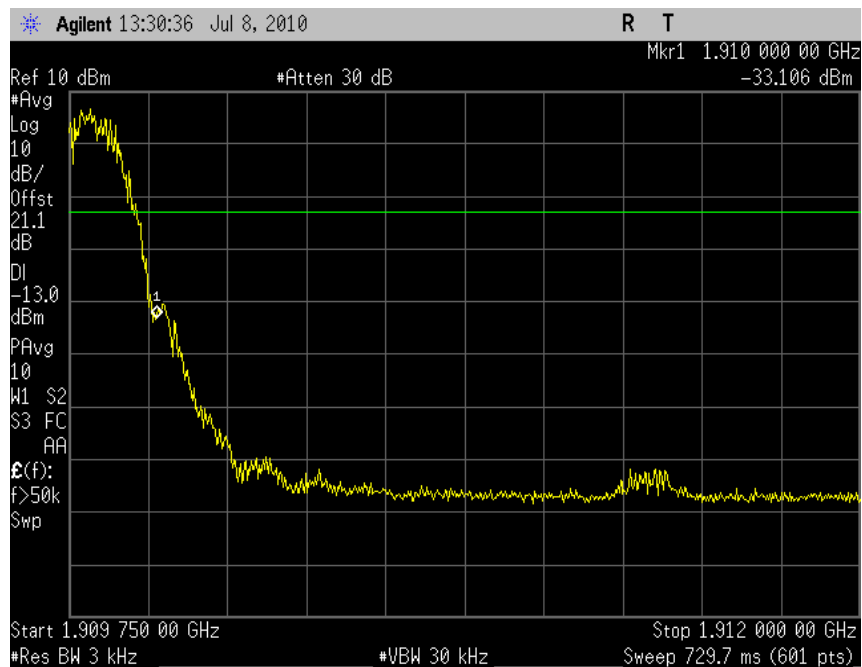

6.1.2 UMTS Band Edge Plots

Plot 6.2-9 (Ch. 4132, Rel. 99)

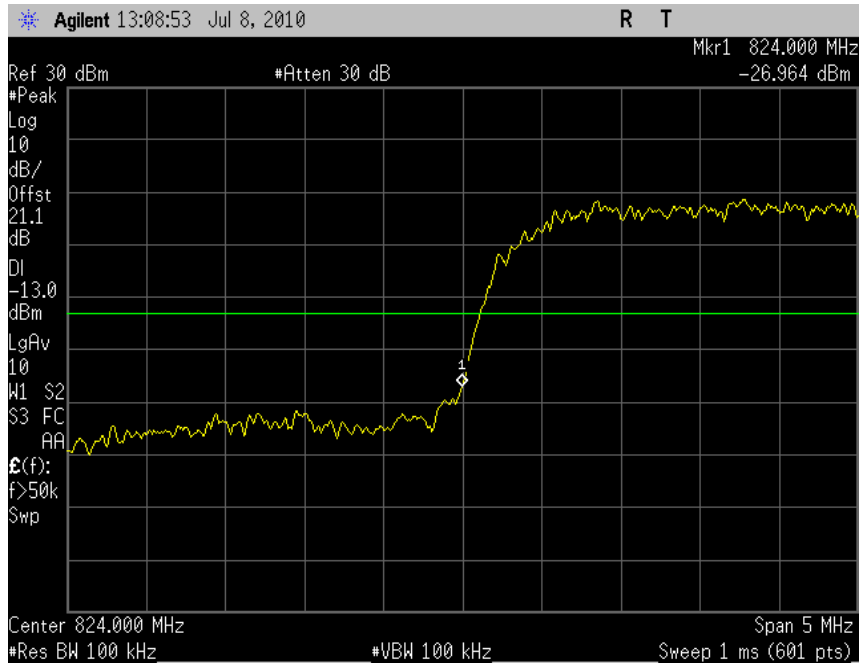

Plot 6.2-10 (Ch. 4233, Rel. 99)

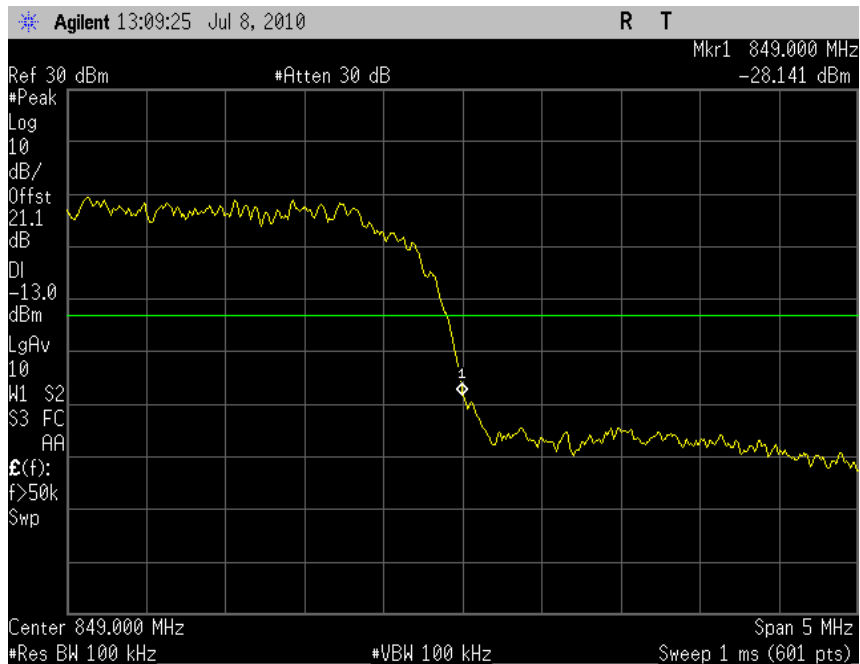

Plot 6.2-11 (Ch. 1312, Rel. 99)

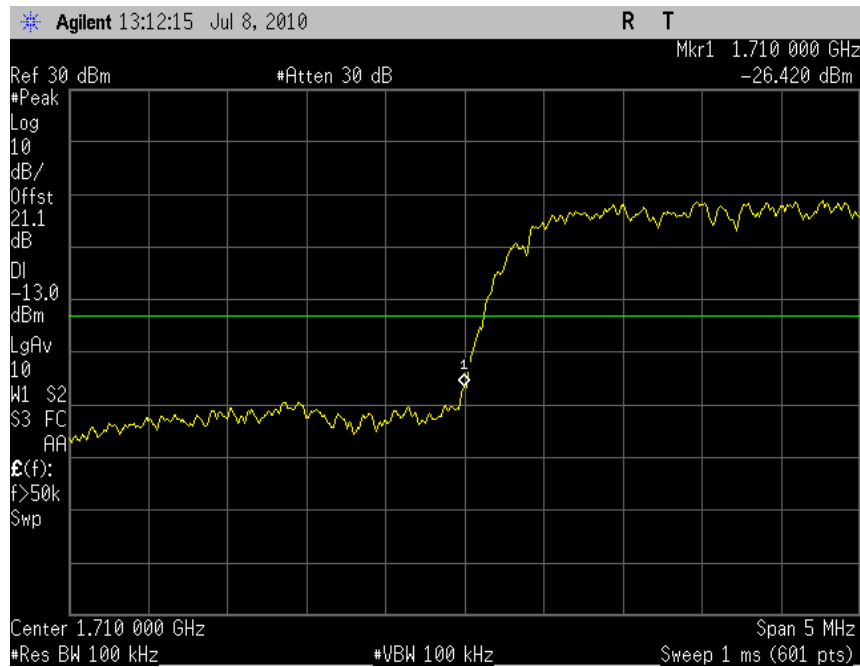

Plot 6.2-12 (Ch. 1513, Rel. 99)

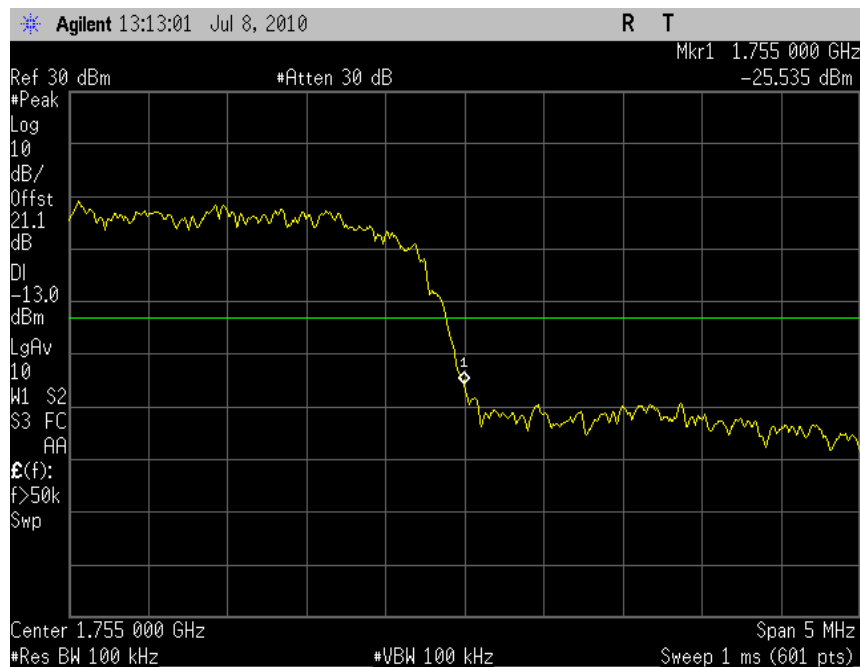

Plot 6.2-13 (Ch. 9262, Rel. 99)

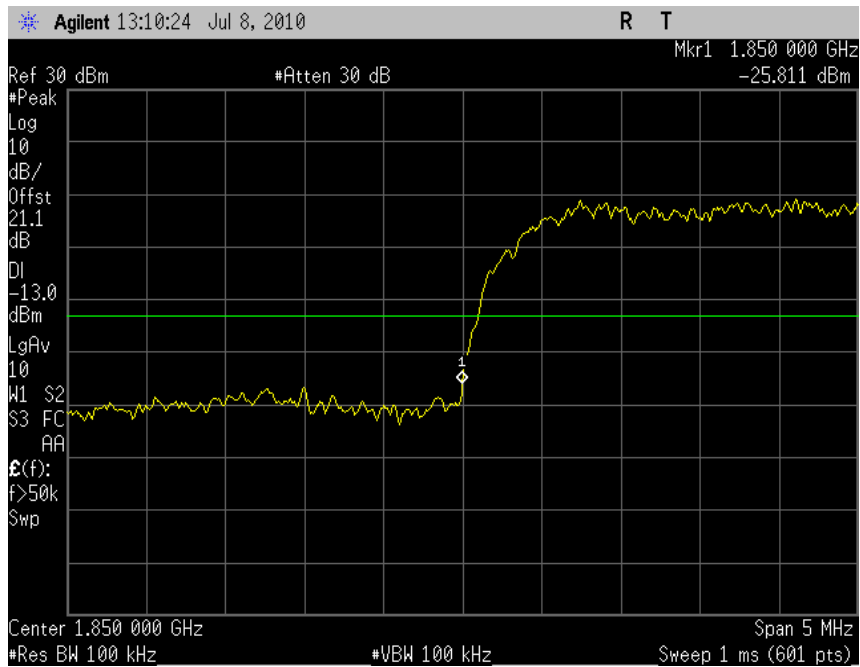

Plot 6.2-14 (Ch. 9538, Rel. 99)

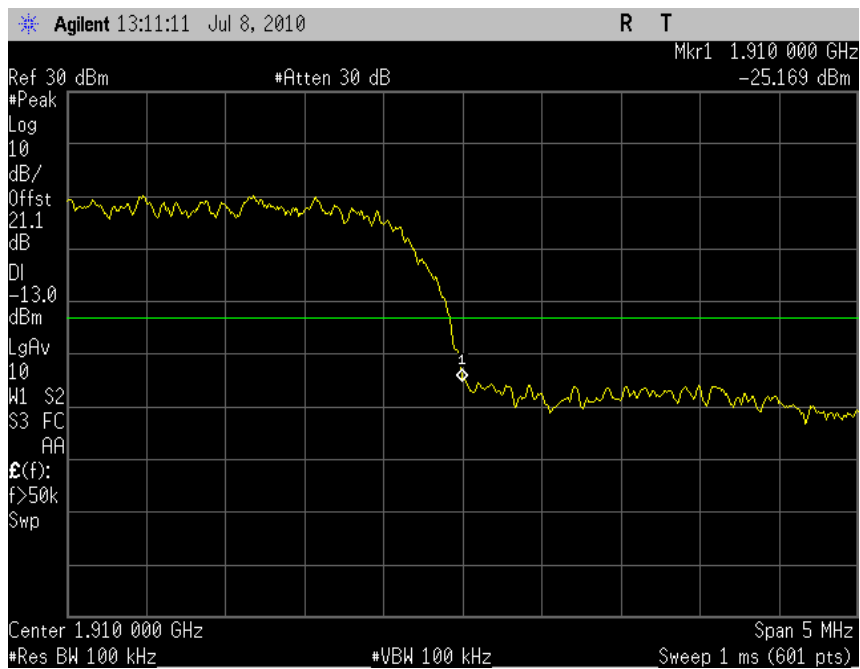

Plot 6.2-15 (Ch. 4132, HSUPA Subtest 5)

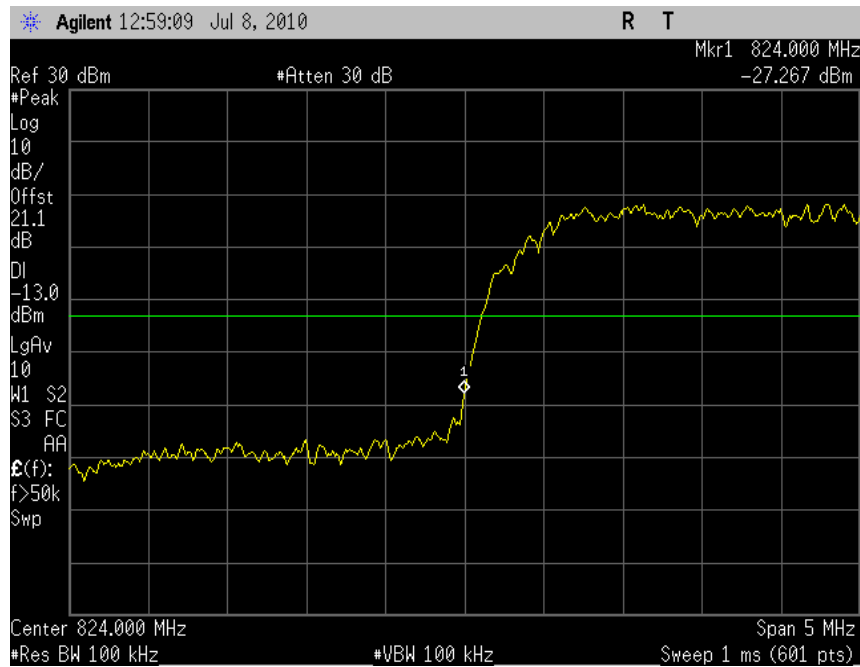

Plot 6.2-16 (Ch. 4233, HSUPA Subtest 5)

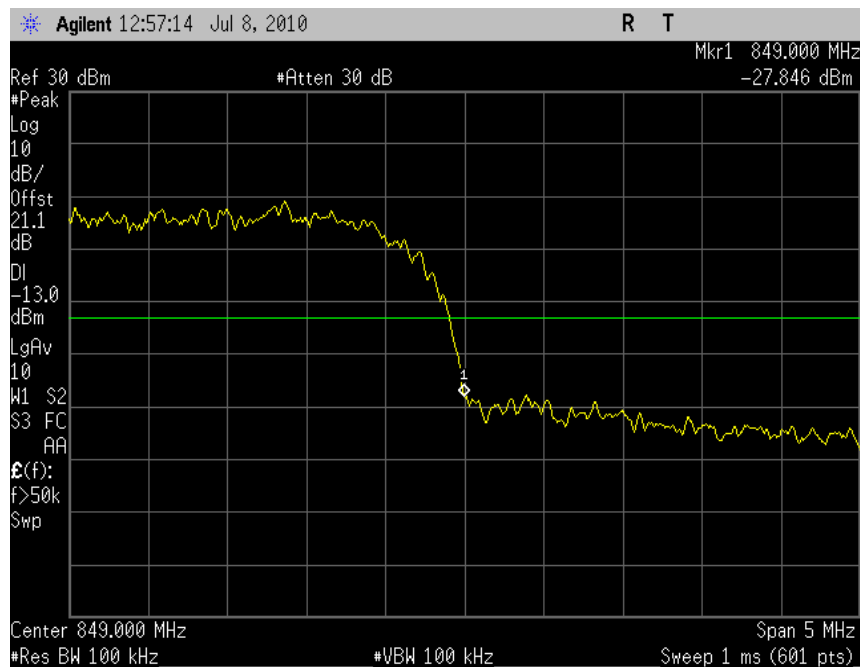

Plot 6.2-17 (Ch. 1312, HSUPA Subtest 5)

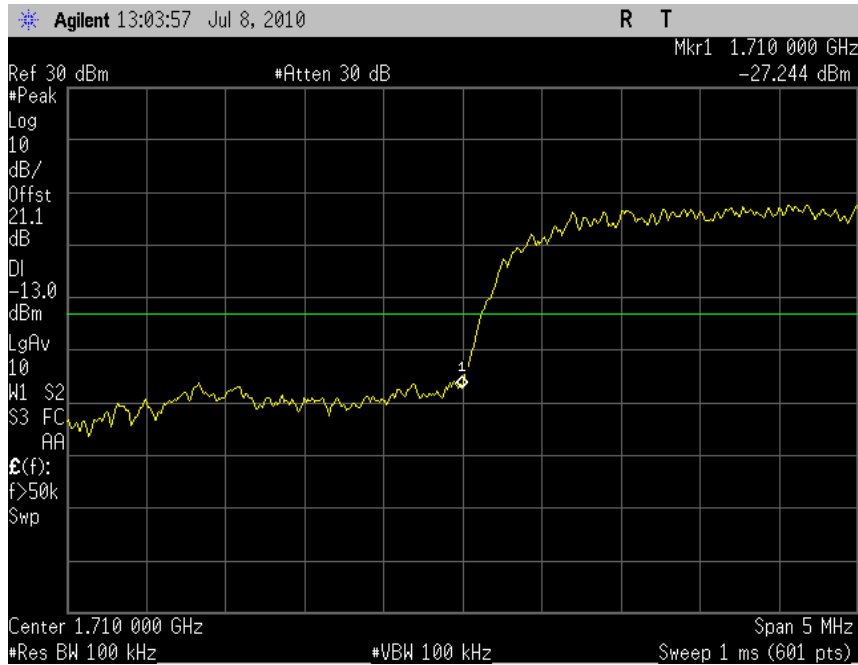

Plot 6.2-18 (Ch. 1513, HSUPA Subtest 5)

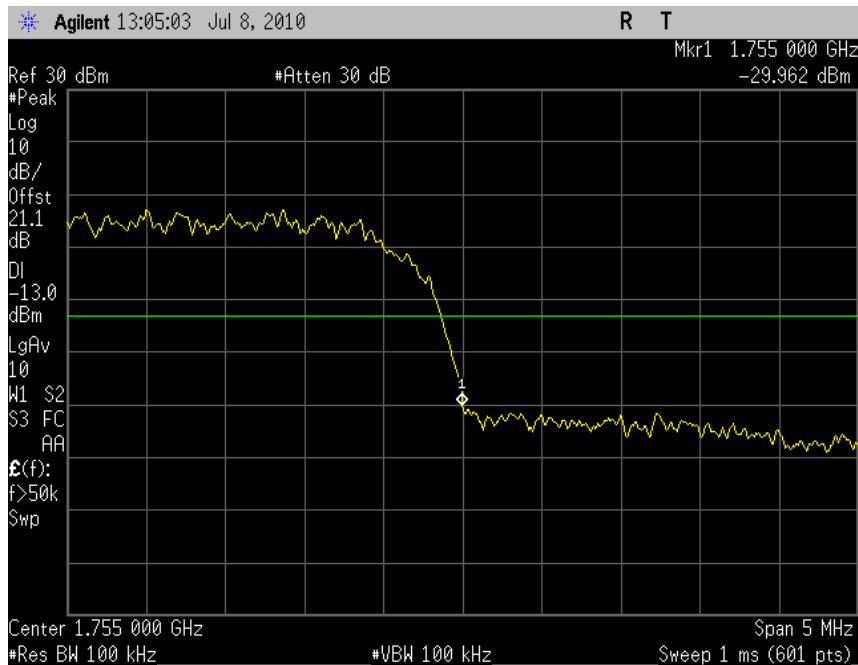

Plot 6.2-19 (Ch. 9262, HSUPA Subtest 5)

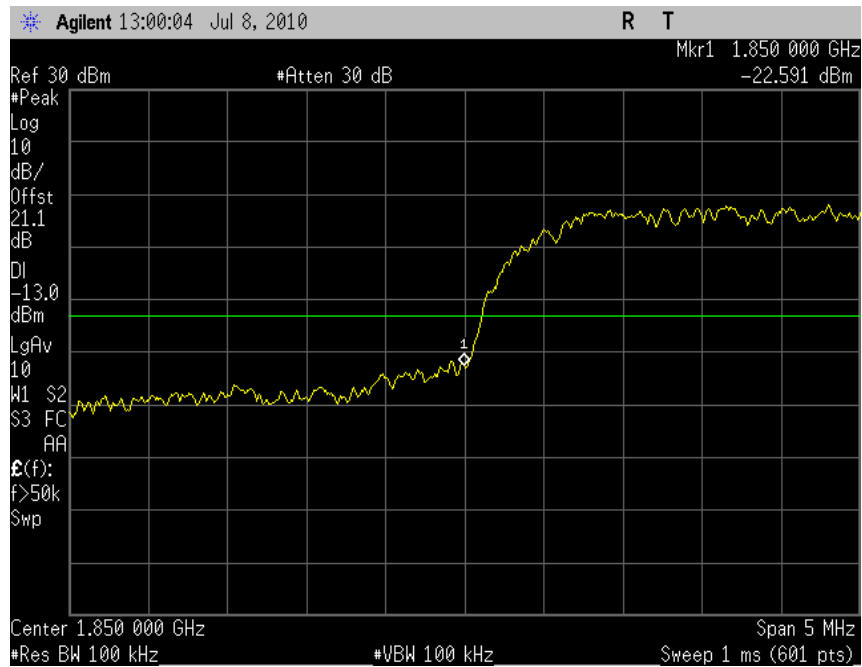

Plot 6.2-20 (Ch. 9538, HSUPA Subtest 5)

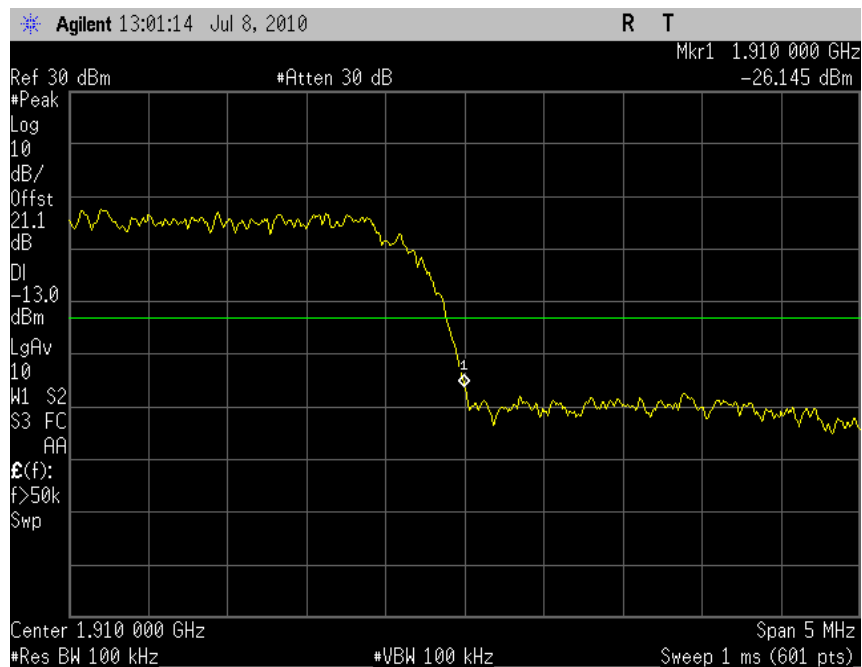

6.1.3 CDMA2000 Band Edge Plots

Plot 6.2-21 (Ch. 1013, RC3 SO55)

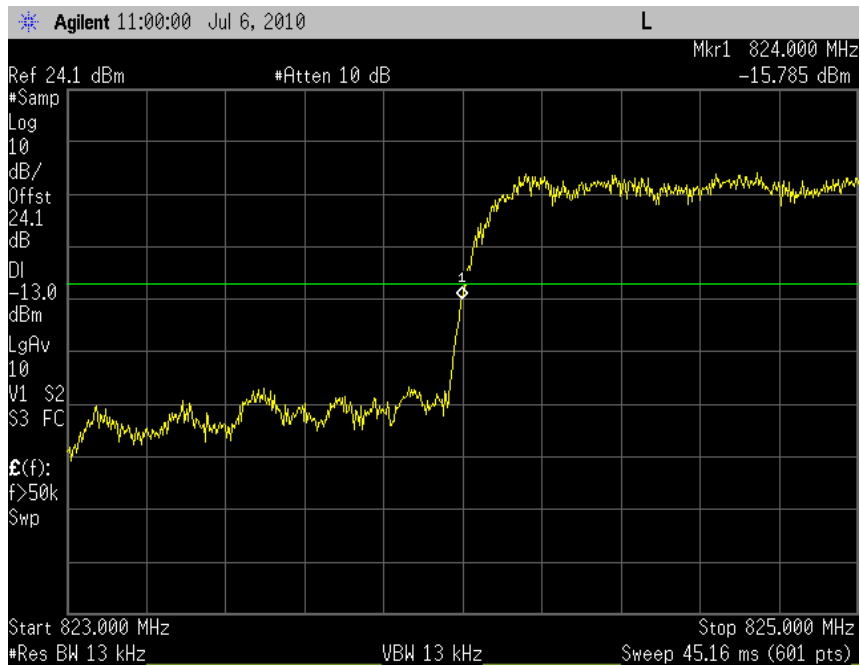

Plot 6.2-22 (Ch. 777, RC3 SO55)

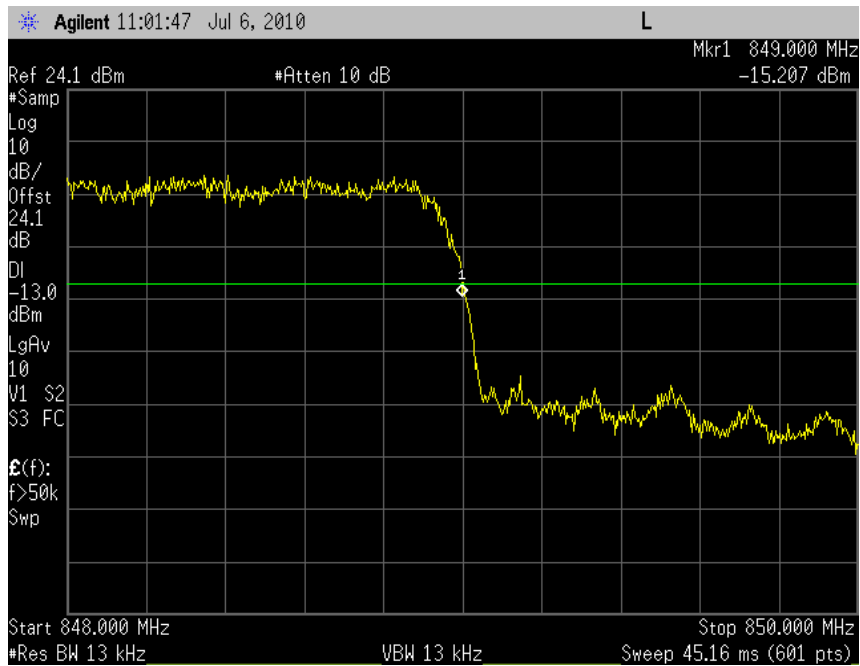

Plot 6.2-23 (Ch. 25, RC3 SO55)

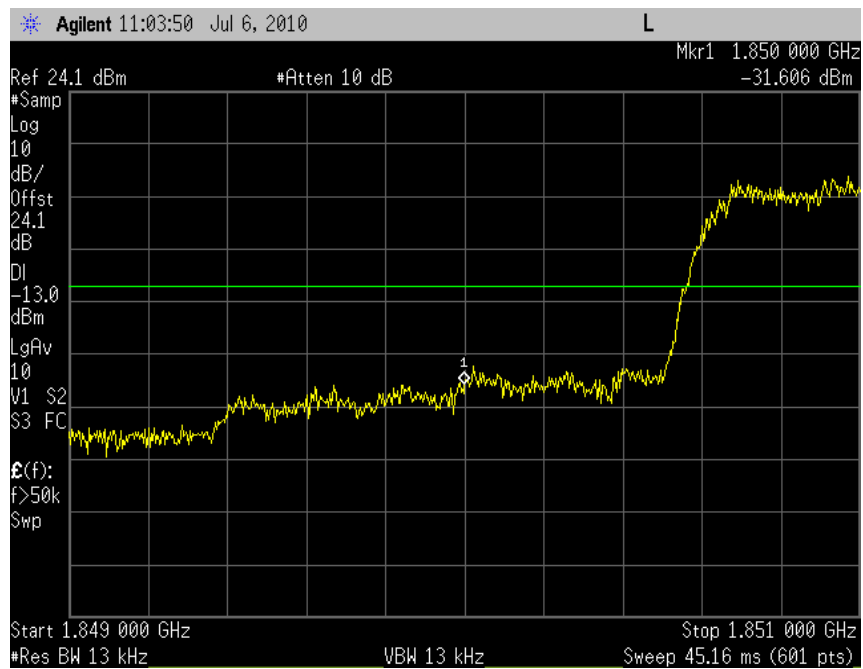

Plot 6.2-24 (Ch. 1175, RC3 SO55)

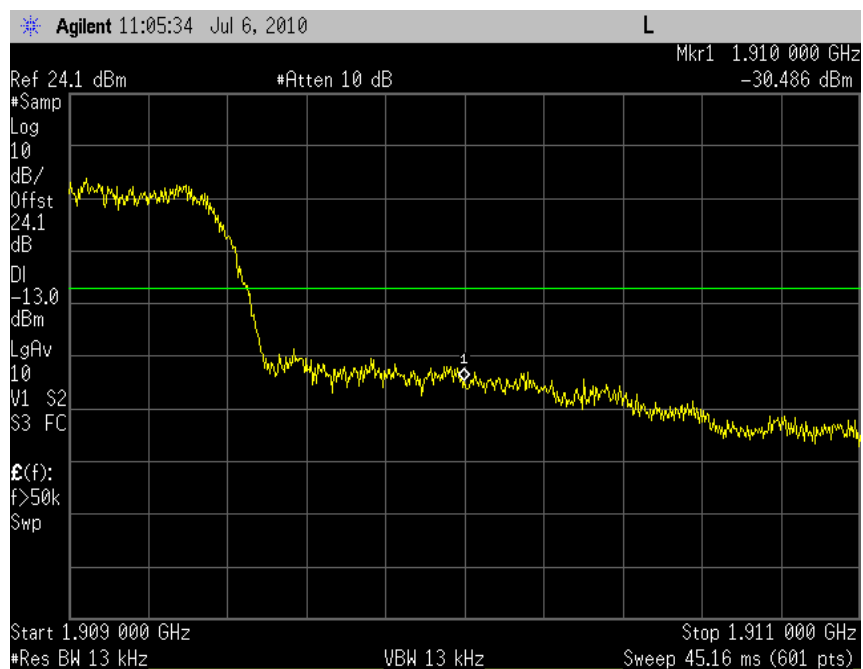

Plot 6.2-25 (Ch. 1013, Rel 0, 153.6 kbps)

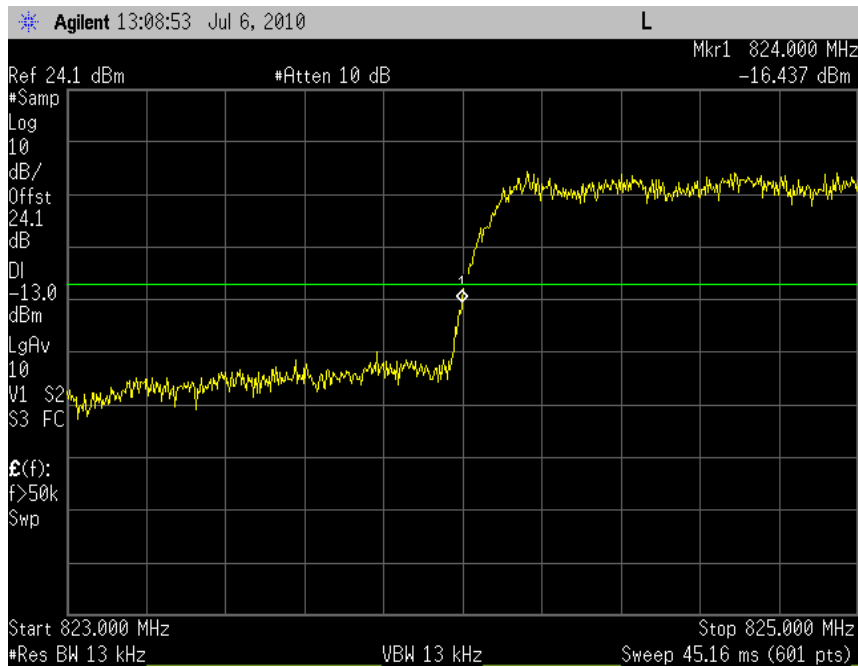

Plot 6.2-26 (Ch. 777, Rel 0, 153.6 kbps)

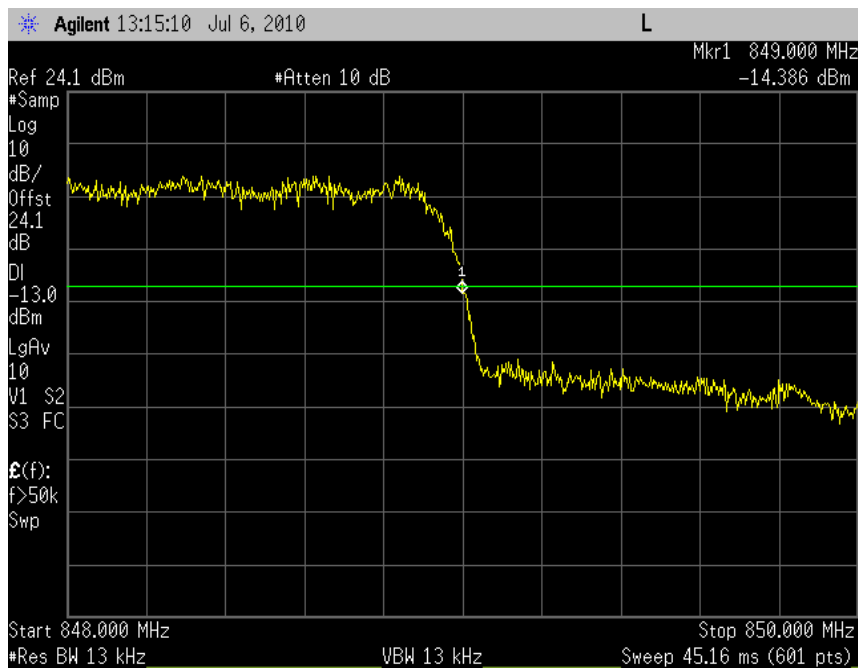

Plot 6.2-27 (Ch. 25, Rel 0, 153.6 kbps)

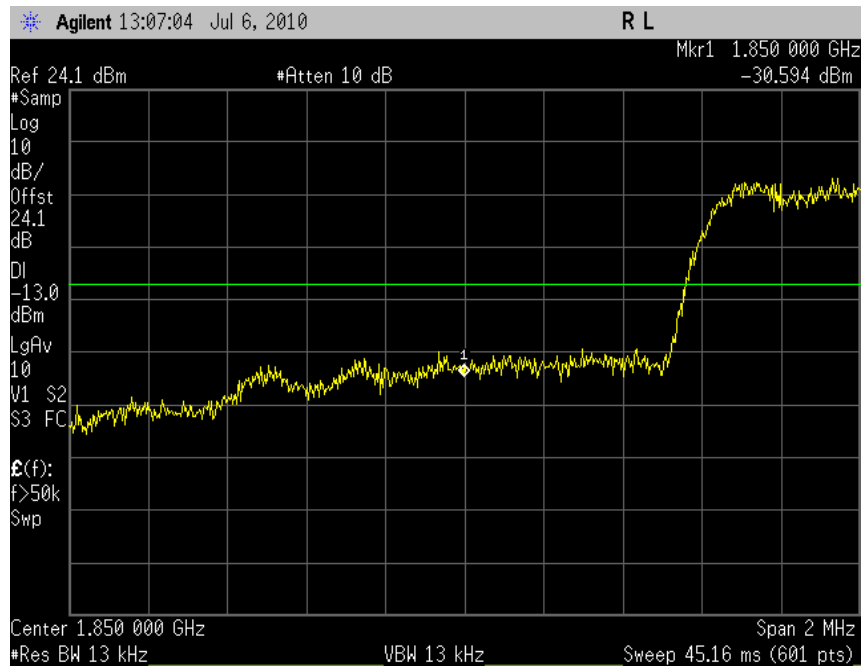

Plot 6.2-28 (Ch. 1175, Rel 0, 153.6 kbps)



Plot 6.2-29 (Ch. 1013, Rev A, 4096 payload)

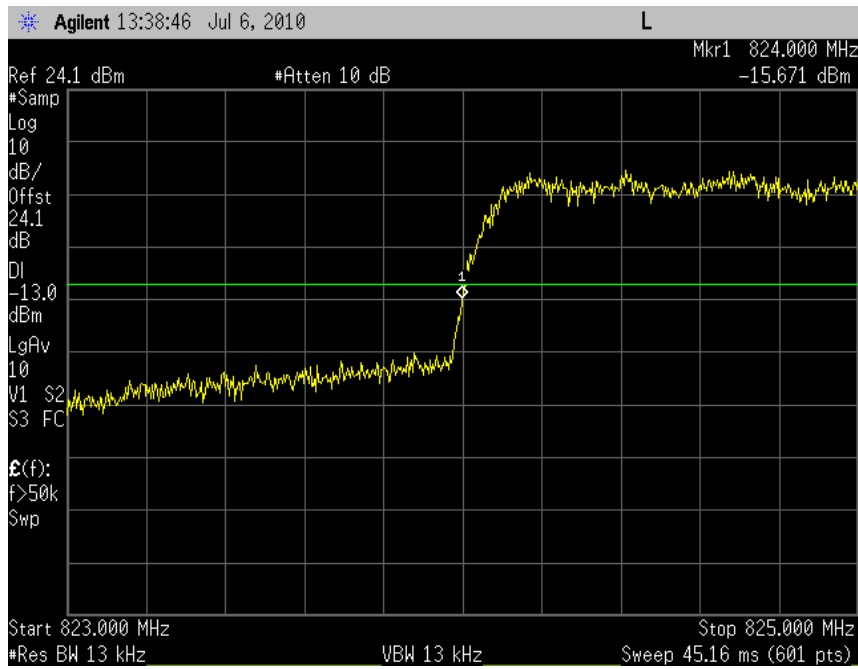

Plot 6.2-30 (Ch. 777, Rev A, 4096 payload)

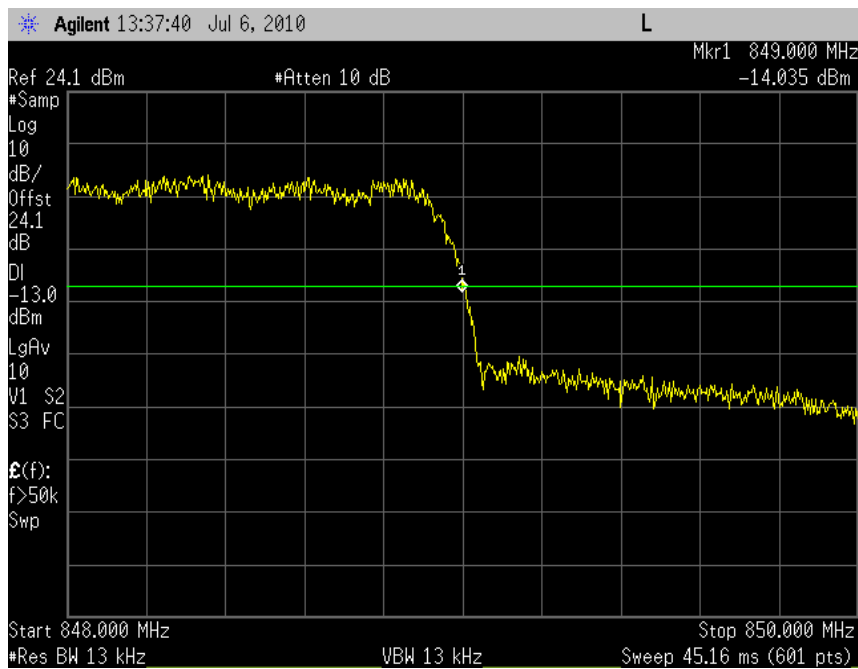

Plot 6.2-31 (Ch. 25, Rev A, 4096 payload)

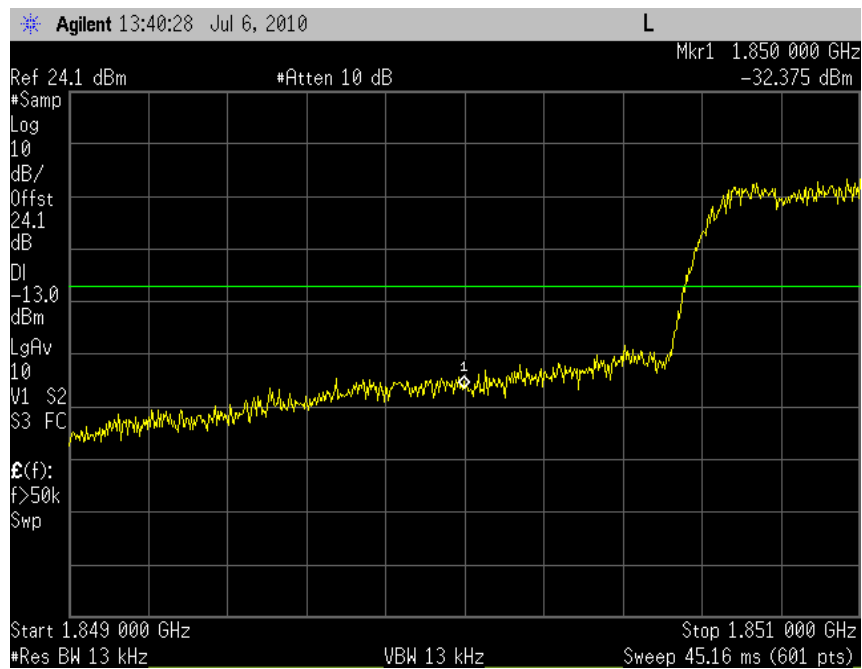

Plot 6.2-32 (Ch. 1175, Rev A, 4096 payload)

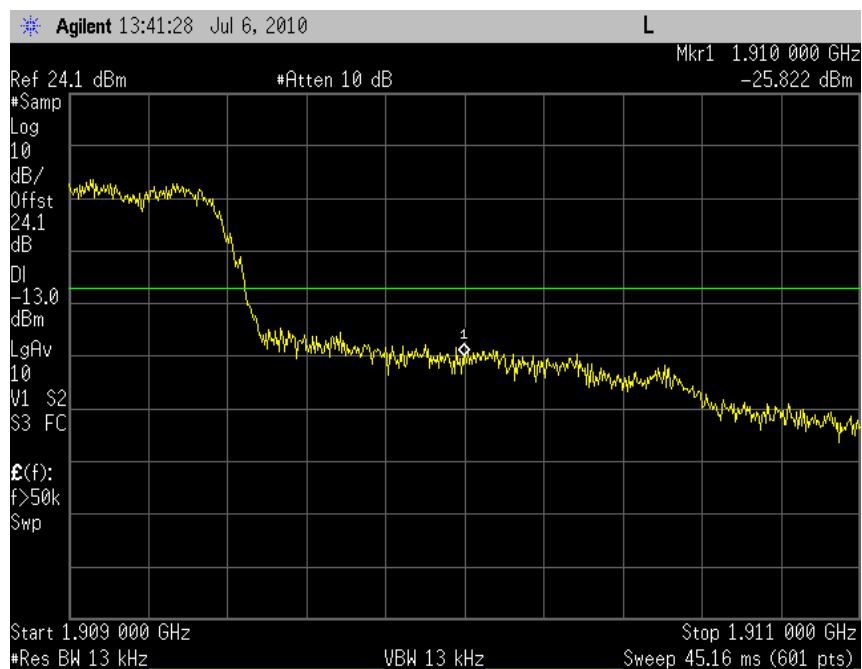

7. Out of Band Emission at Antenna Terminals

FCC:	§22.901(d), 22.917, 24.238 (a), 27.53		
Limit:	-13dBm		
DUT SN	N10F6XTXR		
Modes Tested	CDMA 1x / 1x-EVDO	WCDMA/HSPA	GSM/GPRS/EDGE
	Rel 0, RTAP rate = 153.6kbps	Rel 99	GSM EDGE

7.1 Out of Band Emission Test Procedure

As shown in the figure below, the RF output to the spectrum analyzer is connected through a calibrated coaxial cable. Scan the out-of-band emission up to 10th harmonics. Set RBW and VBW as 100 kHz for the measurement below 1GHz, and 1MHz for testing above 1GHz. Recorded multiple sweeps in maximum hold mode using a peak detector to ensure that the worst case emission was caught.

The 8960 call box was used for CDMA 1x/1x-EVDO and UMTS measurements.

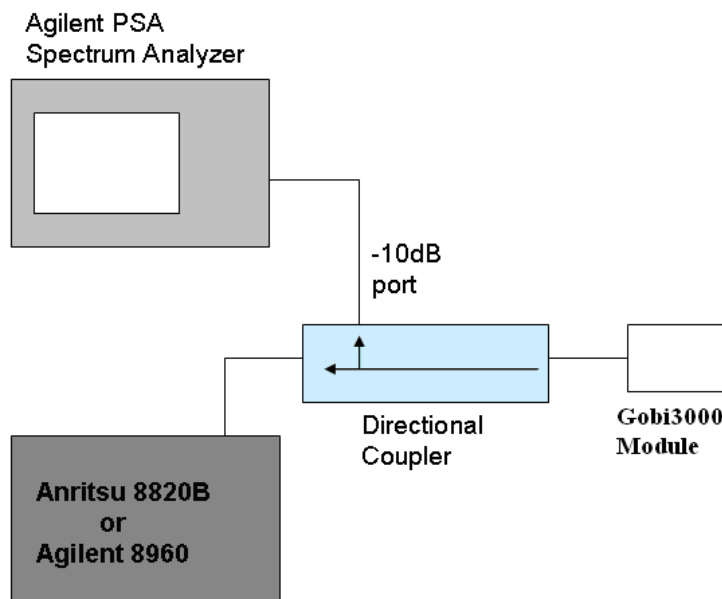

7.2 Emission Test Results

The test was conducted at low, mid and high channel in each band.

Mode	Frequency Range Tested	Tx Channel	Corresponding Plot number	Test Result	
GSM/ GPRS/ EDGE	GMSK	0 ~ 20 GHz	128	Plot 7.2 - 1, 2	Complies
		0 ~ 20 GHz	190	Plot 7.2 - 3, 4	Complies
		0 ~ 20 GHz	251	Plot 7.2 - 5, 6	Complies
		0 ~ 20 GHz	512	Plot 7.2 - 7, 8	Complies
		0 ~ 20 GHz	661	Plot 7.2 - 9, 10	Complies
		0 ~ 20 GHz	810	Plot 7.2 - 11, 12	Complies
	8PSK	0 ~ 20 GHz	128	Plot 7.2 - 13, 14	Complies
		0 ~ 20 GHz	190	Plot 7.2 - 15, 16	Complies
		0 ~ 20 GHz	251	Plot 7.2 - 17, 18	Complies
		0 ~ 20 GHz	512	Plot 7.2 - 19, 20	Complies
		0 ~ 20 GHz	661	Plot 7.2 - 21, 22	Complies
		0 ~ 20 GHz	810	Plot 7.2 - 23, 24	Complies

Mode		Frequency Range Tested	Tx Channel	Corresponding Plot number	Test Result
WCDMA/ HSDPA/ HSUPA	Rel 99	0 ~ 20 GHz	4132	Plot 7.2 - 25, 26	Complies
		0 ~ 20 GHz	4182	Plot 7.2 - 27, 28	Complies
		0 ~ 20 GHz	4233	Plot 7.2 - 29, 30	Complies
		0 ~ 20 GHz	1312	Plot 7.2 - 31, 32	Complies
		0 ~ 20 GHz	1427	Plot 7.2 - 33, 34	Complies
		0 ~ 20 GHz	1513	Plot 7.2 - 35, 36	Complies
		0 ~ 20 GHz	9262	Plot 7.2 - 37, 38	Complies
		0 ~ 20 GHz	9400	Plot 7.2 - 39, 40	Complies
		0 ~ 20 GHz	9538	Plot 7.2 - 41, 42	Complies

Mode		Frequency (MHz)	Channel Tested	Corresponding Plot number	Test Result
CDMA1x/ 1x-EVDO	Rel 0 RTAP rate = 153.6kbps	0 ~ 20 GHz	1013	Plot 7.2 - 43, 44	Complies
		0 ~ 20 GHz	384	Plot 7.2 - 45, 46	Complies
		0 ~ 20 GHz	777	Plot 7.2 - 47, 48	Complies
		0 ~ 20 GHz	25	Plot 7.2 - 49, 50	Complies
		0 ~ 20 GHz	600	Plot 7.2 - 51, 52	Complies
		0 ~ 20 GHz	1175	Plot 7.2 - 53, 54	Complies

7.2.1 GSM Emissions Plots

Plot 7.2 - 1 (GMSK Ch128)

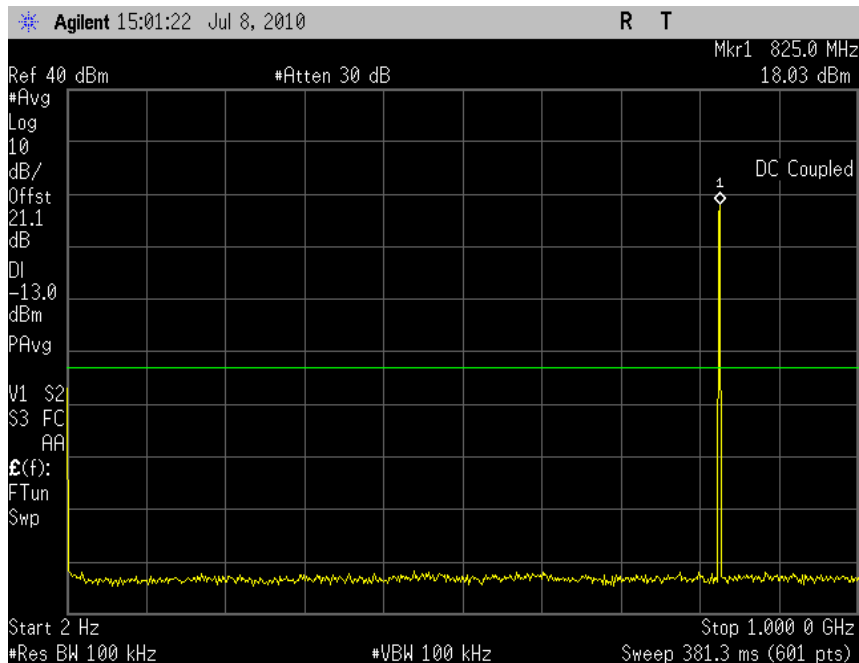

Plot 7.2 - 2 (GMSK Ch128)

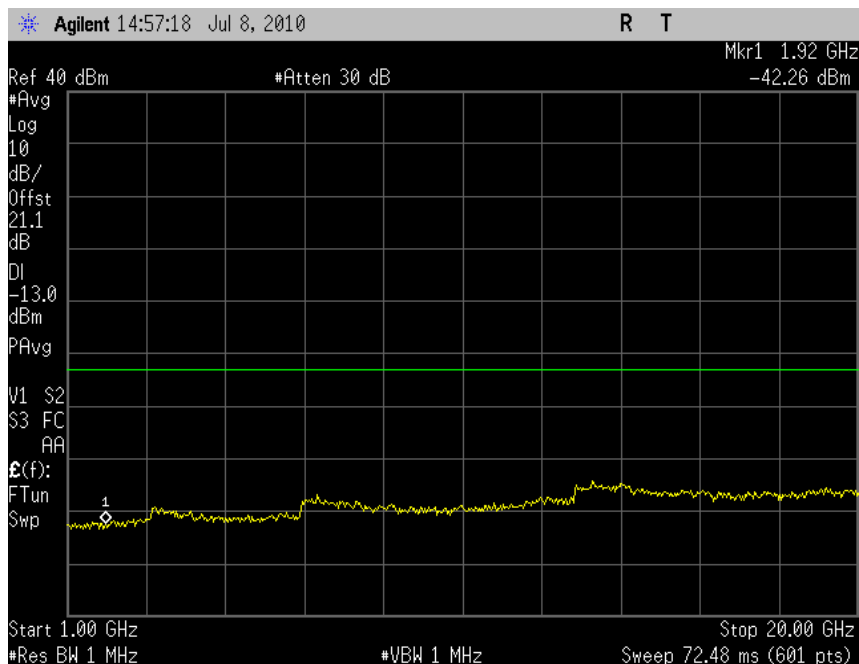

Plot 7.2 - 3 (8PSK Ch190)

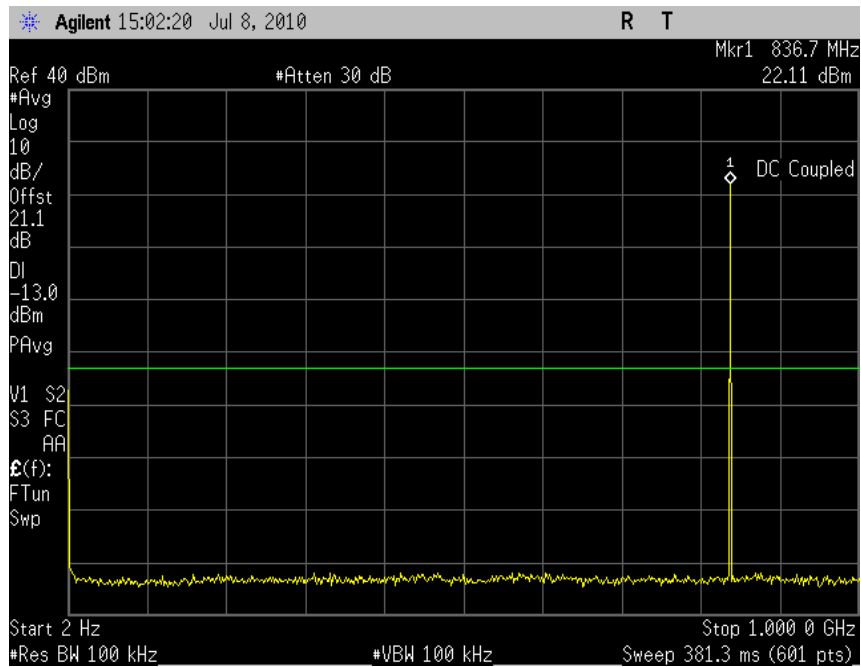

Plot 7.2 - 4 (8PSK Ch190)

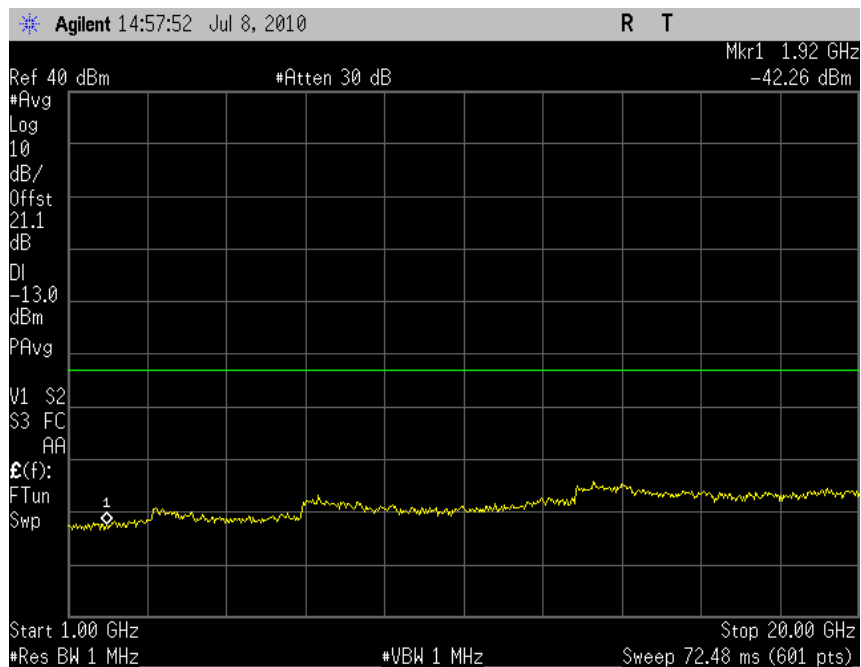

Plot 7.2 -5 (GMSK Ch251)

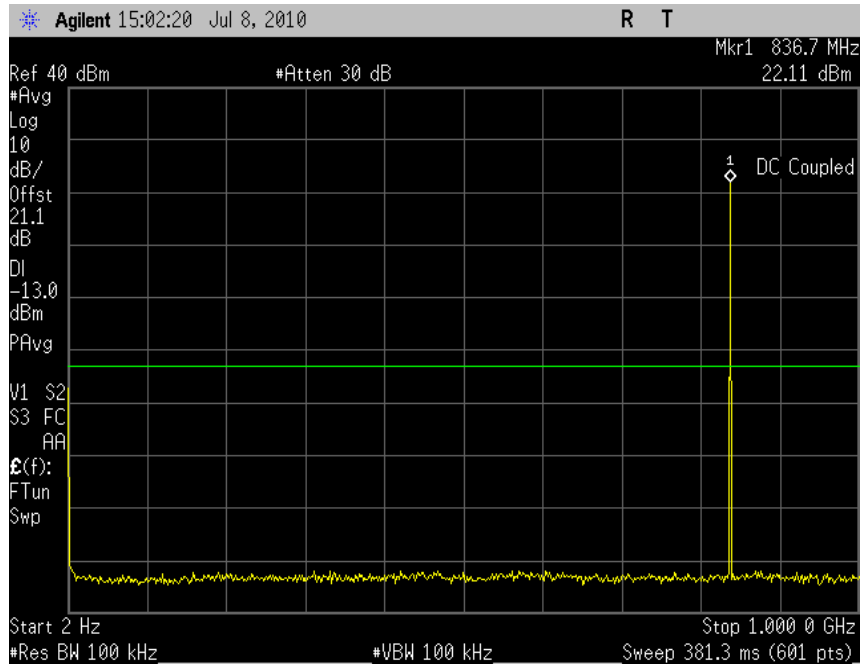

Plot 7.2 -6 (GMSK Ch251)

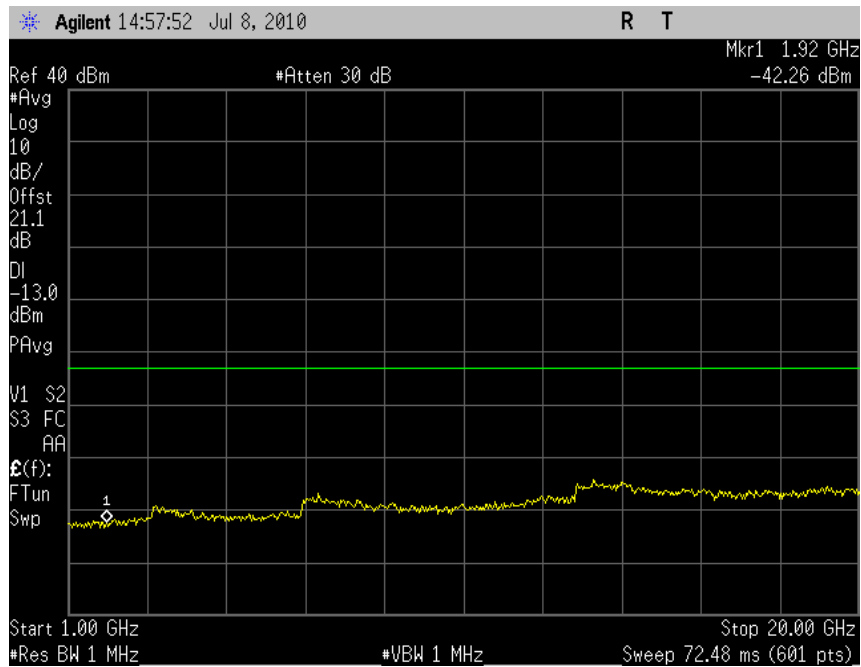

Plot 7.2 -7 (GMSK Ch512)

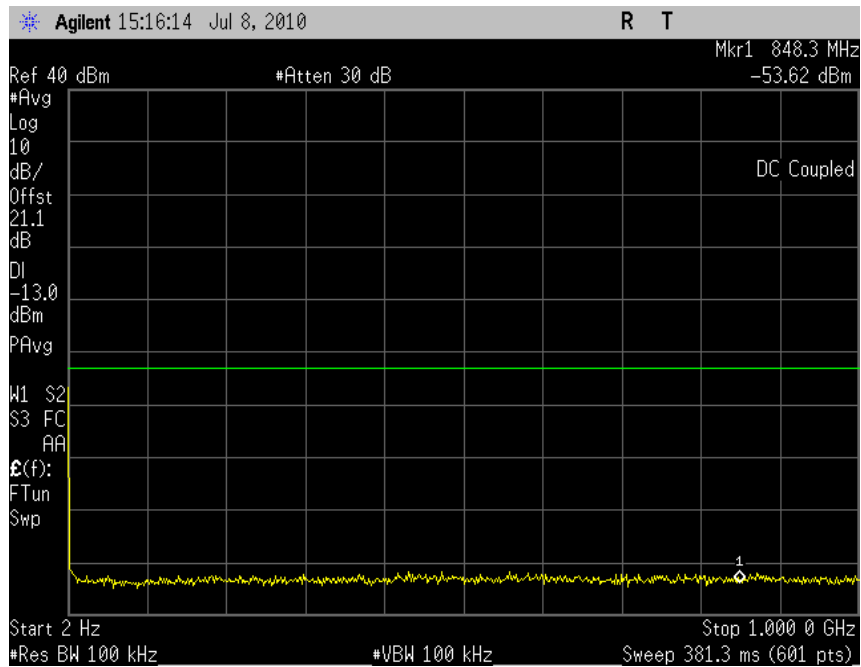

Plot 7.2 -8 (GMSK Ch512)

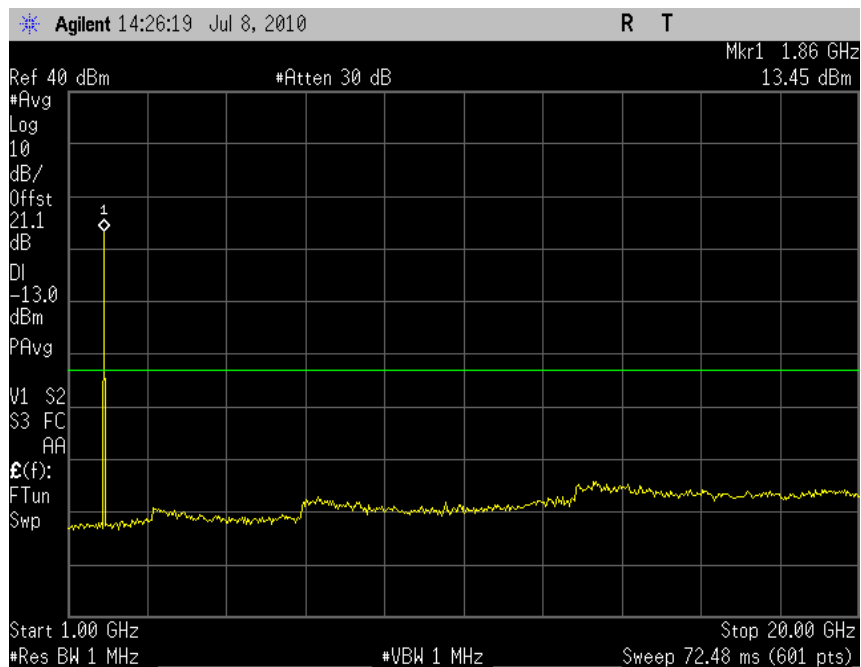

Plot 7.2 -9 (8PSK Ch661)

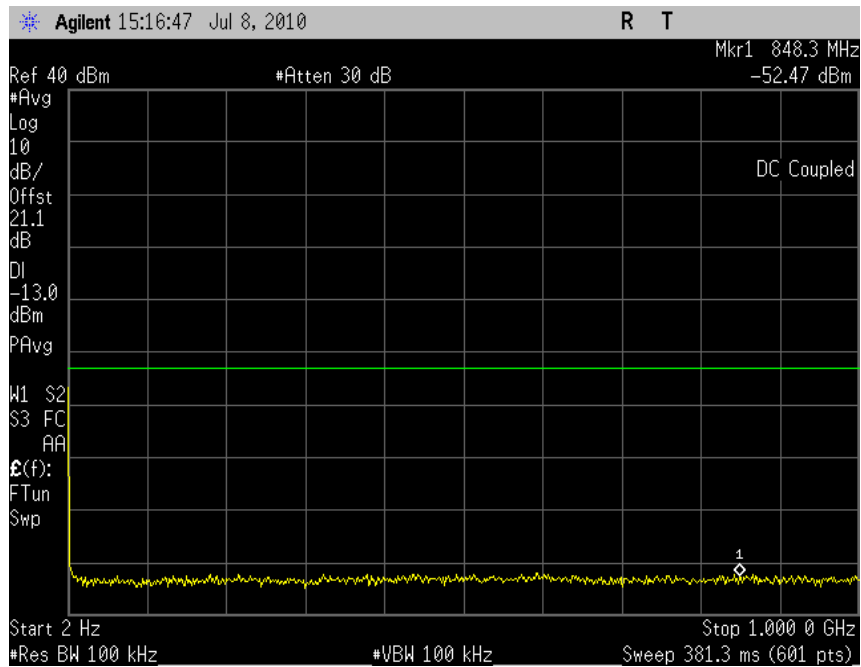

Plot 7.2 -10 (8PSK Ch661)

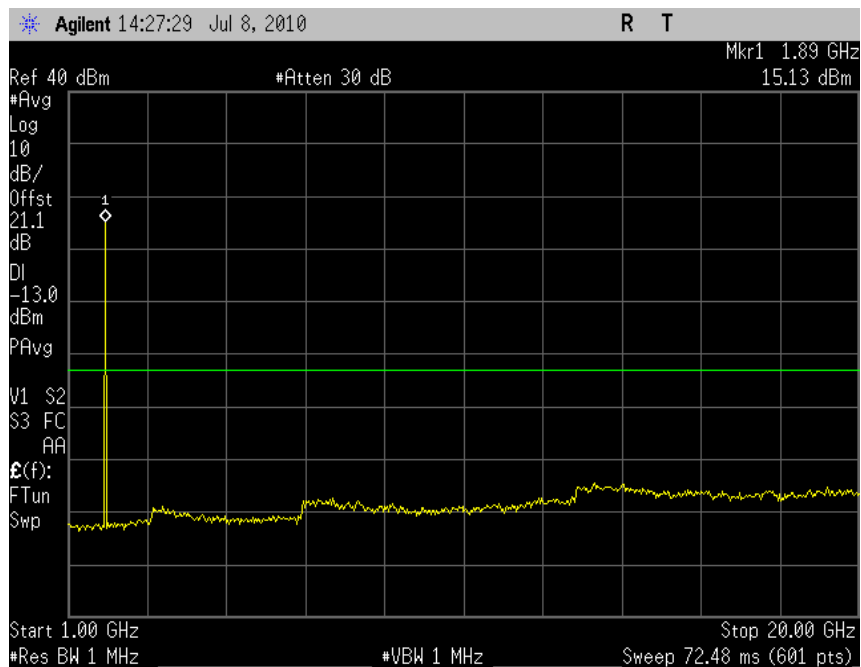

Plot 7.2 -11 (GMSK Ch810)

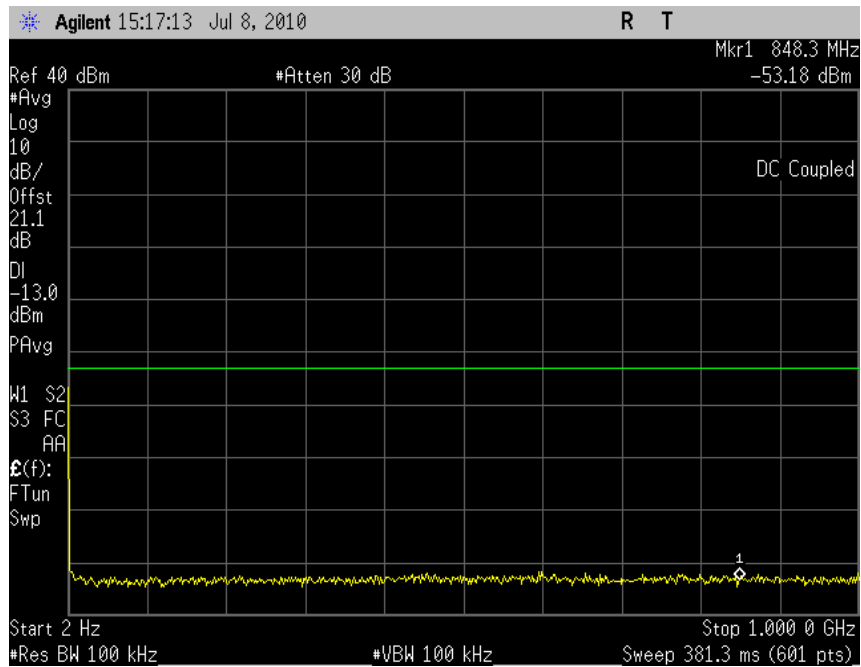

Plot 7.2 -12 (GMSK Ch810)

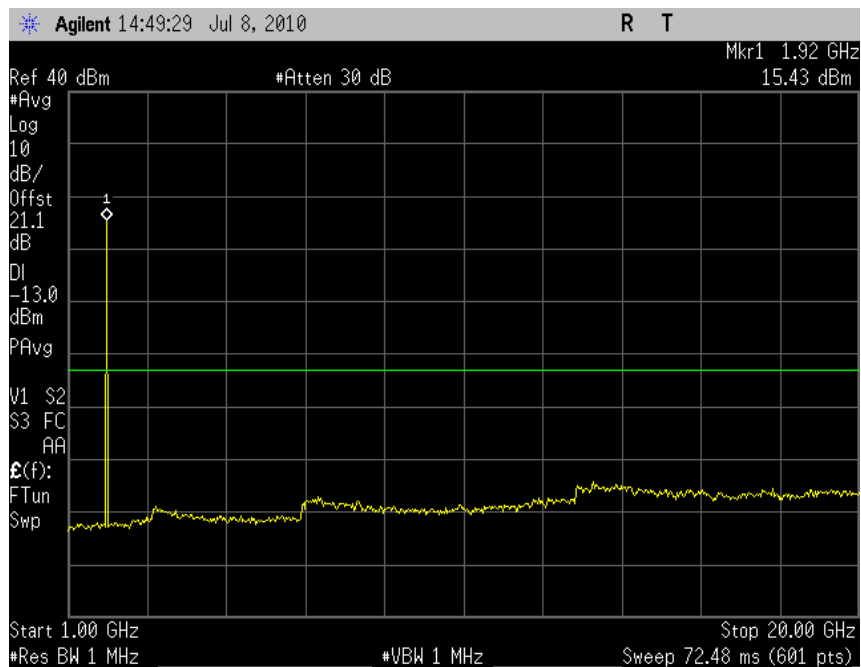

Plot 7.2 -13 (8PSK Ch128)

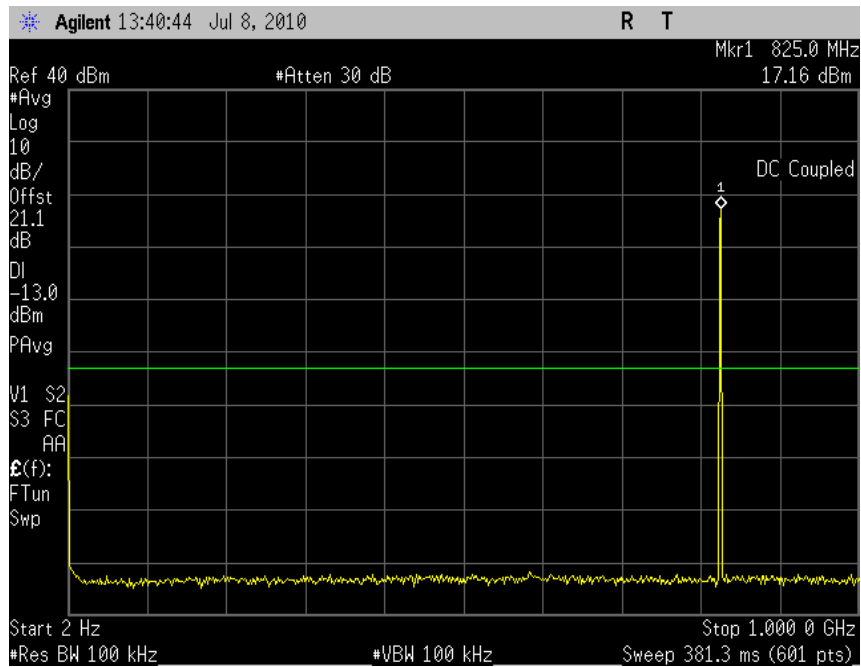

Plot 7.2 -14 (8PSK Ch128)

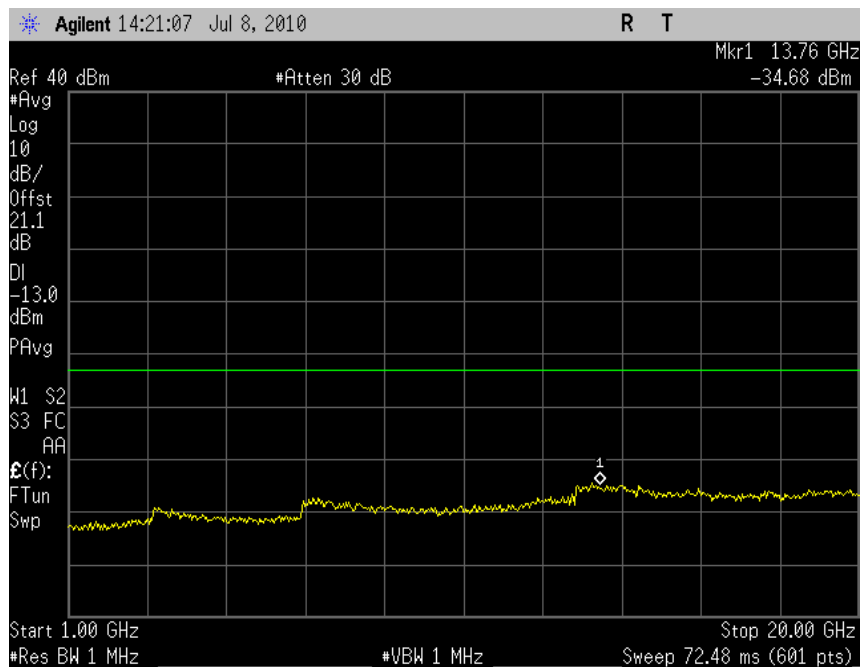

Plot 7.2 -15 (8PSK Ch190)

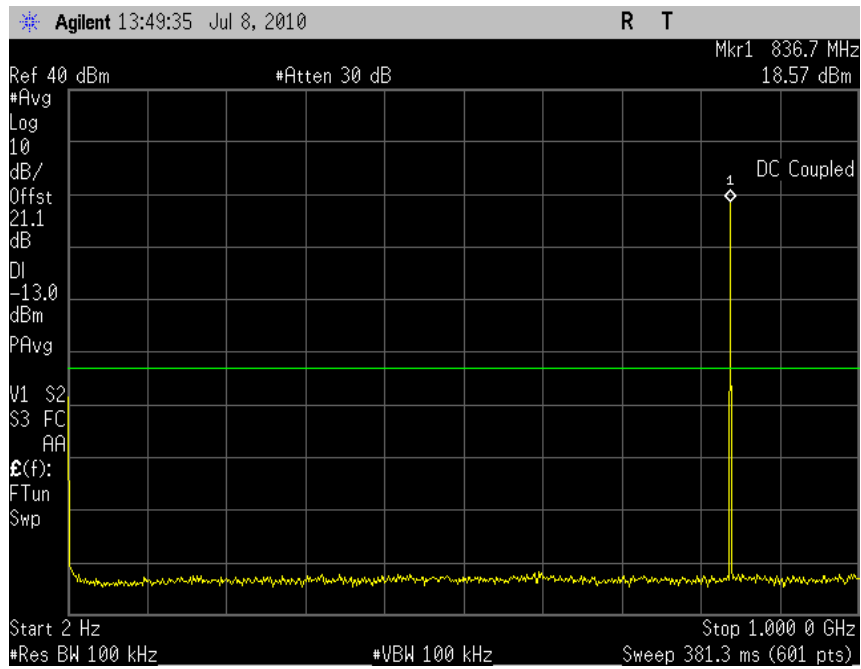

Plot 7.2 -16 (8PSK Ch190)

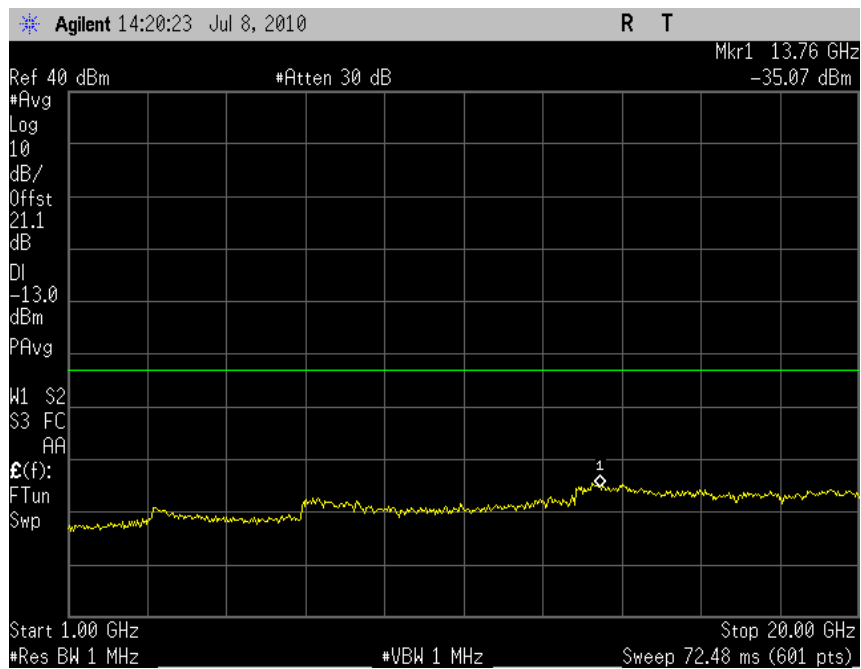

Plot 7.2 -17 (8PSK Ch251)

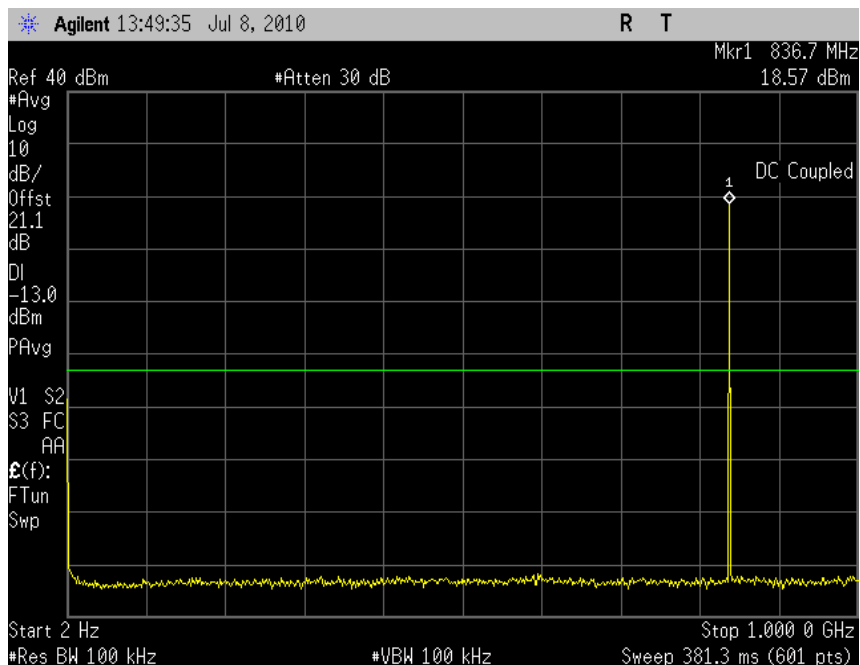

Plot 7.2 -18 (8PSK Ch251)

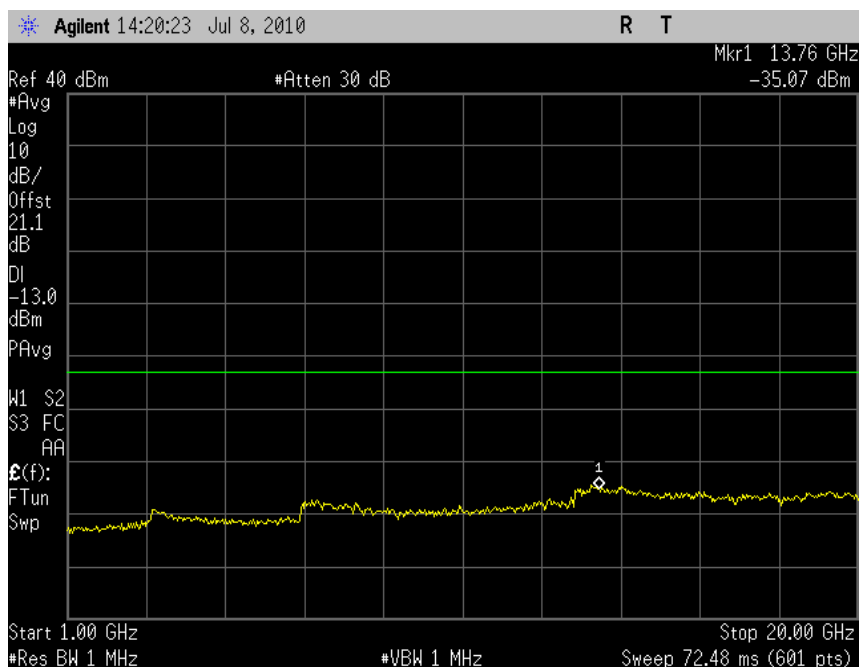

Plot 7.2 -19 (8PSK Ch512)

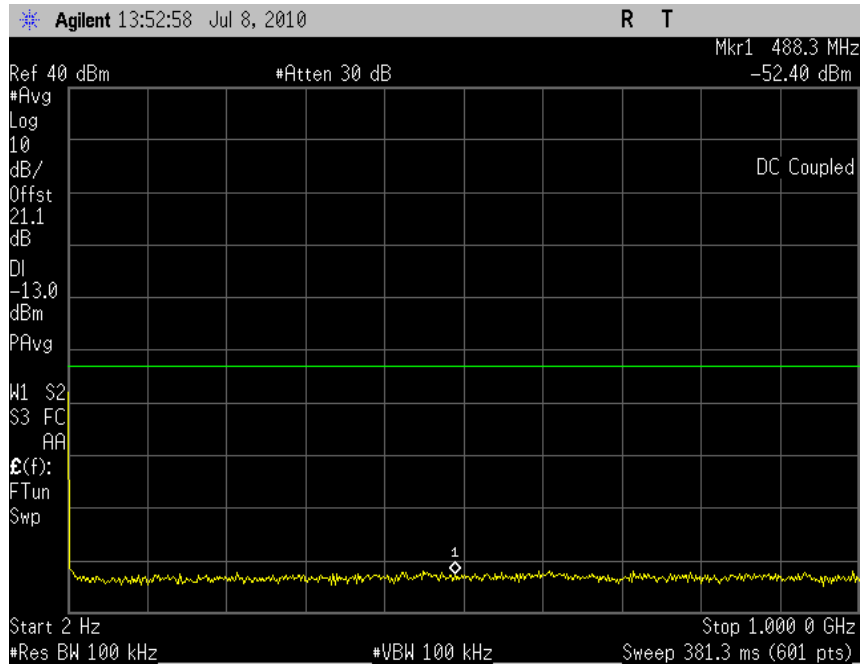

Plot 7.2 -20 (8PSK Ch512)

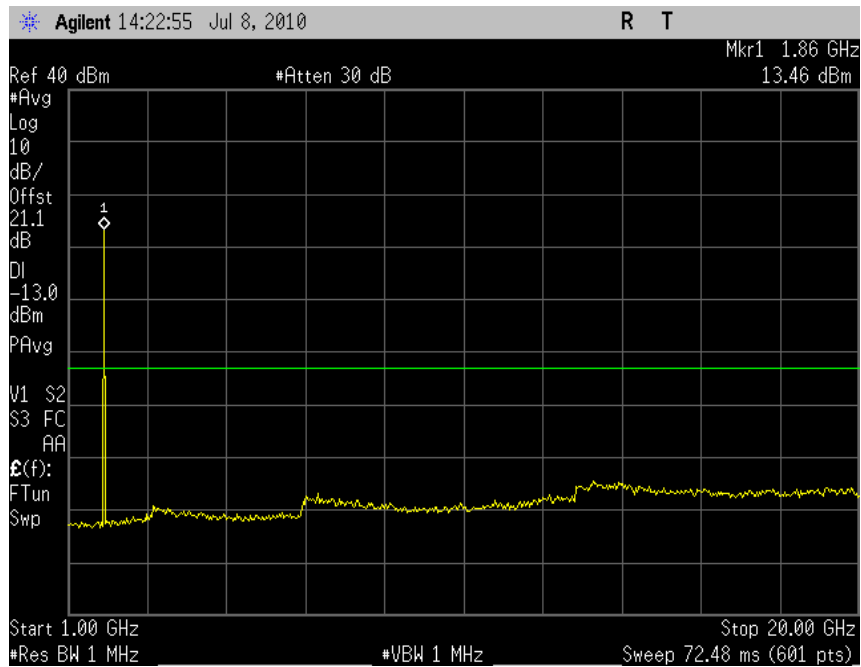

Plot 7.2 - 21 (8PSK Ch661)

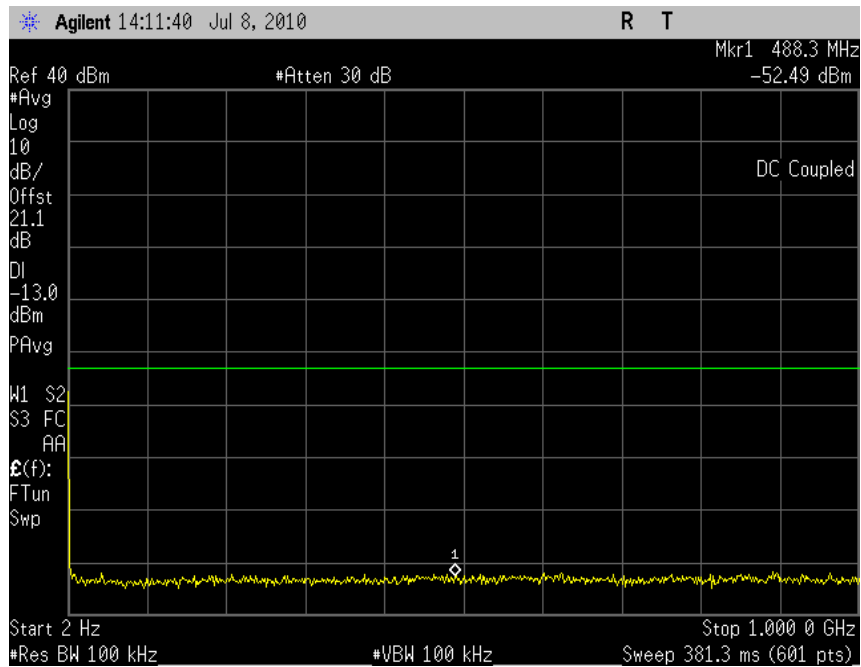

Plot 7.2 - 22 (8PSK Ch661)

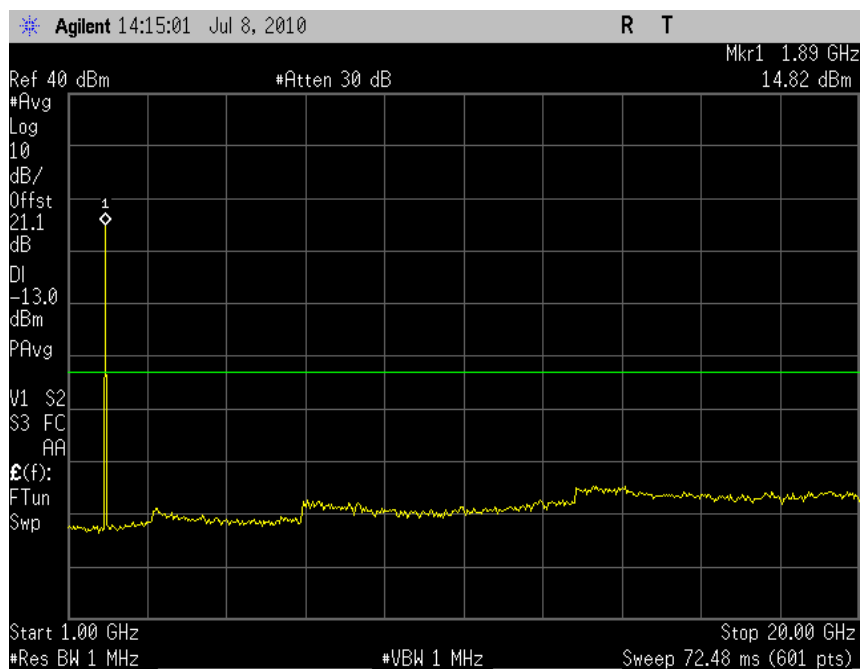

Plot 7.2 - 23 (8PSK Ch810)

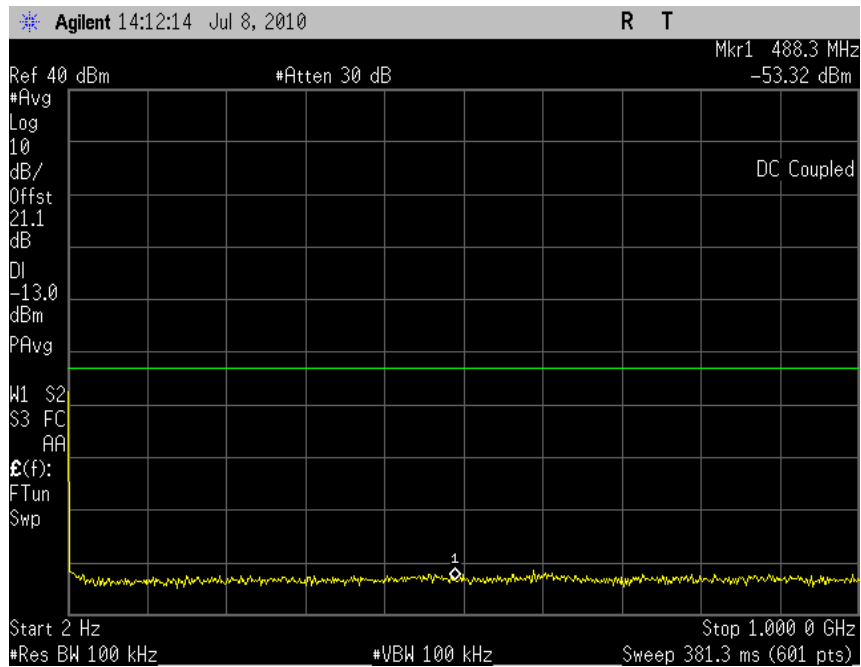

Plot 7.2 - 24 (8PSK Ch810)

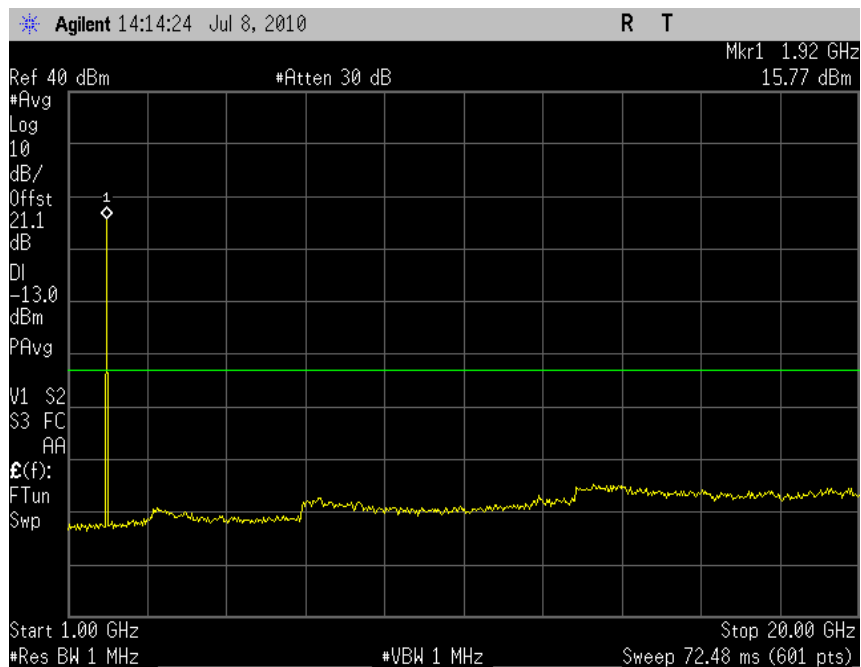

7.2.2 UMTS Emissions Plots

Plot 7.2 - 25 (Rel99, Ch4132)

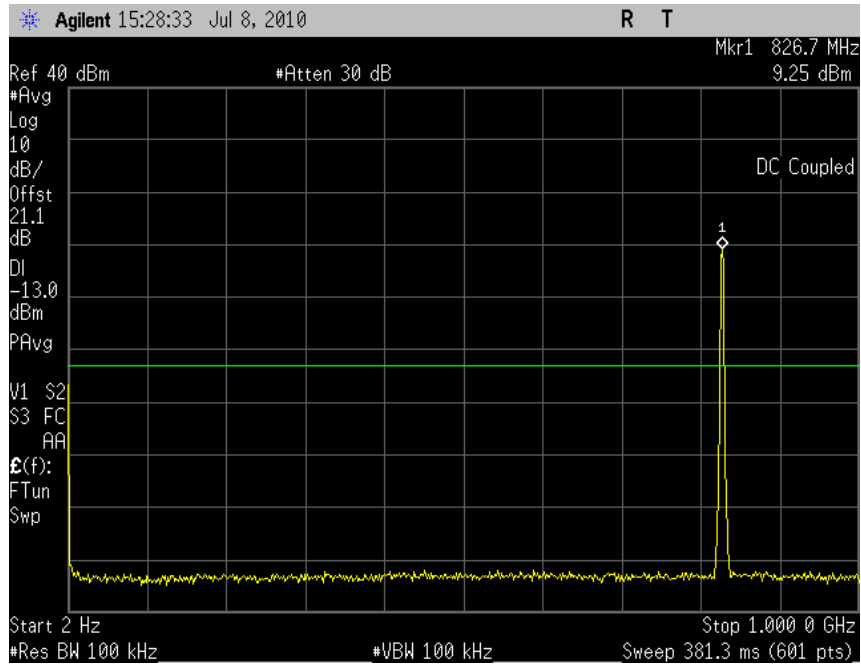

Plot 7.2 - 26 (Rel99, Ch4132)

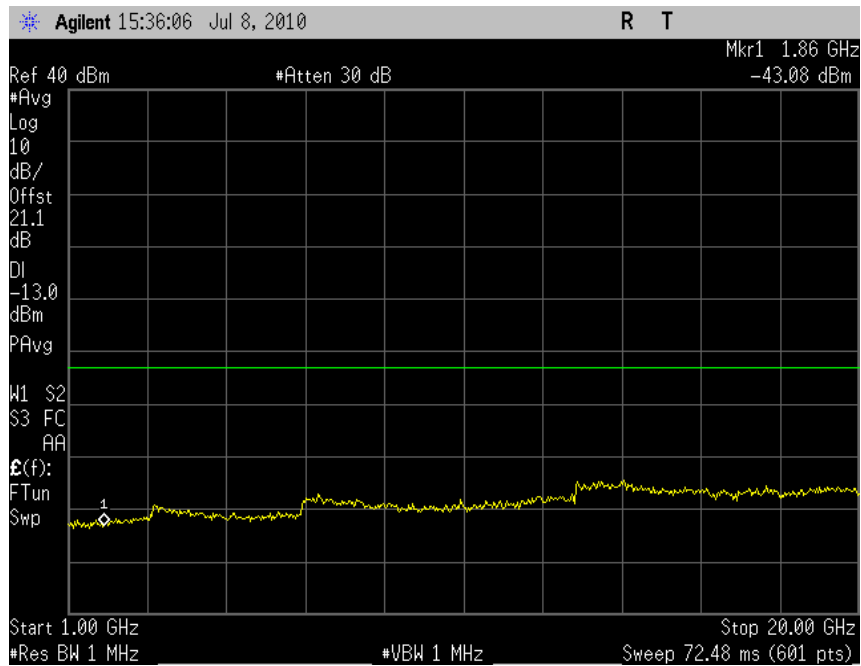

Plot 7.2 - 27 (Rel99, Ch4182)

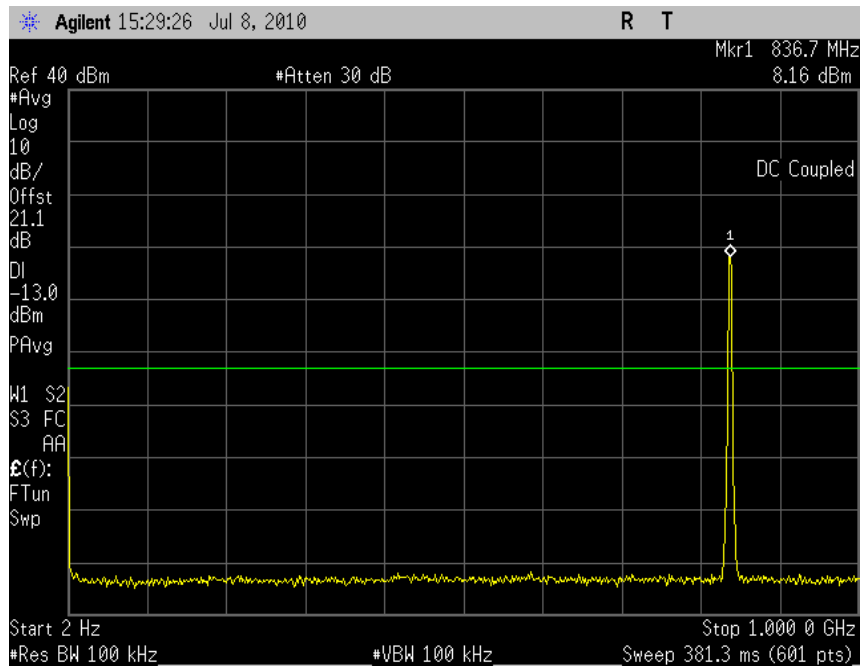

Plot 7.2 - 28 (Rel99, Ch4182)

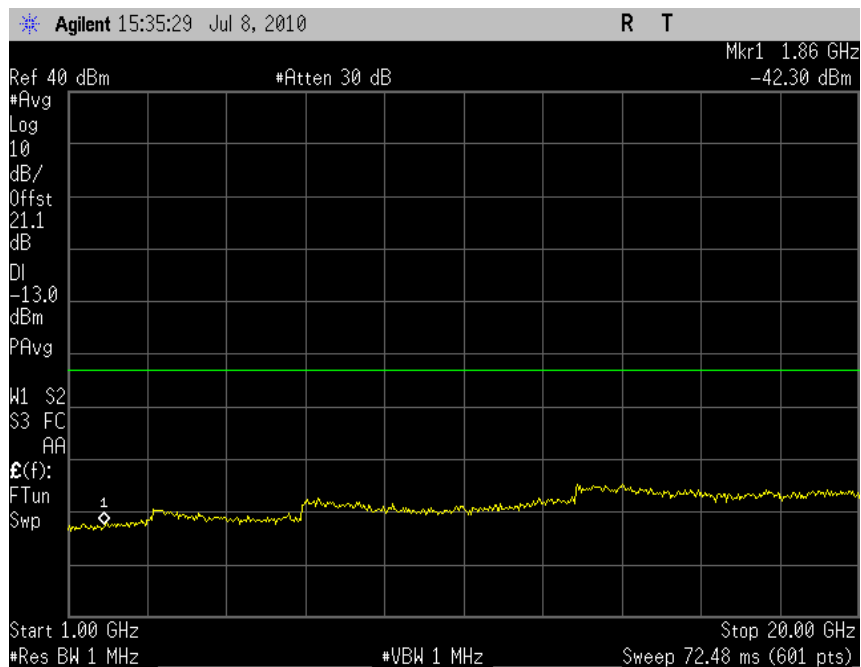

Plot 7.2 - 29 (Rel99, Ch4233)

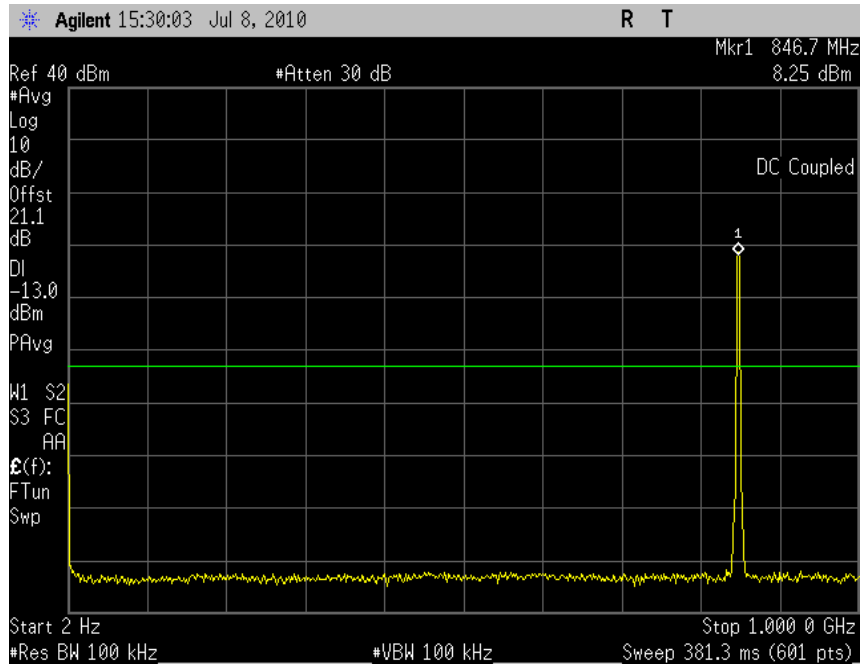

Plot 7.2 - 30 (Rel99, Ch4233)

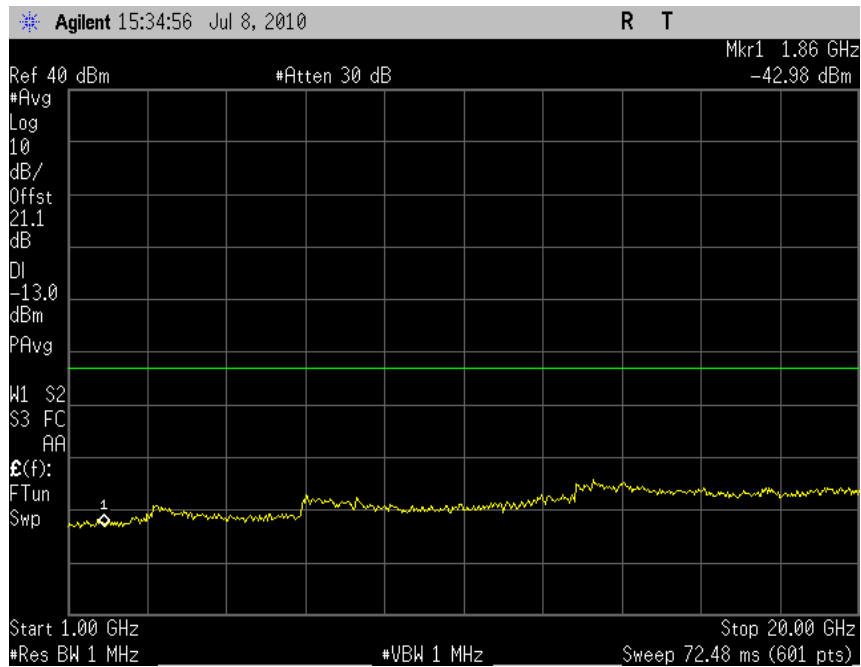

Plot 7.2 - 31 (Rel99, Ch1312)

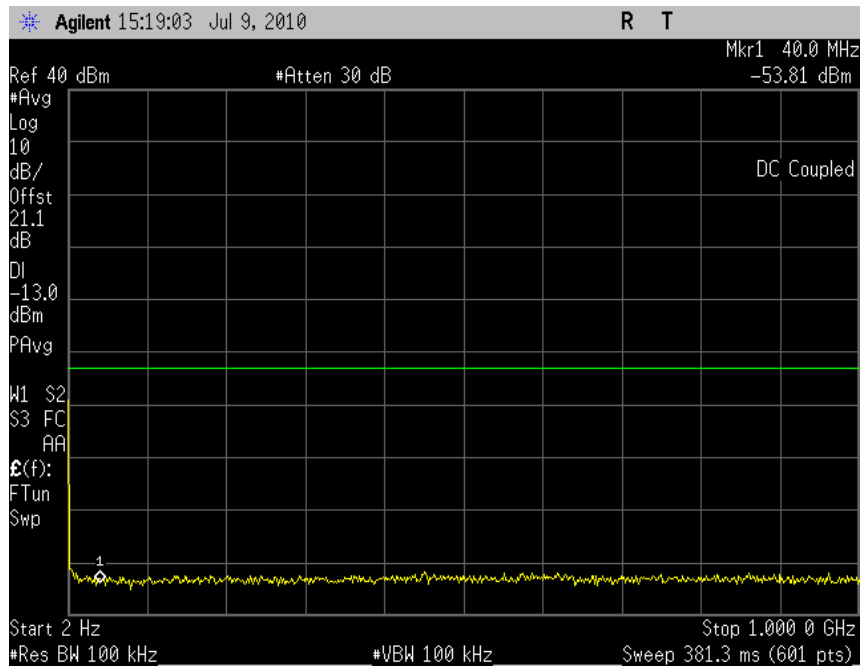

Plot 7.2 - 32 (Rel99, Ch1312)

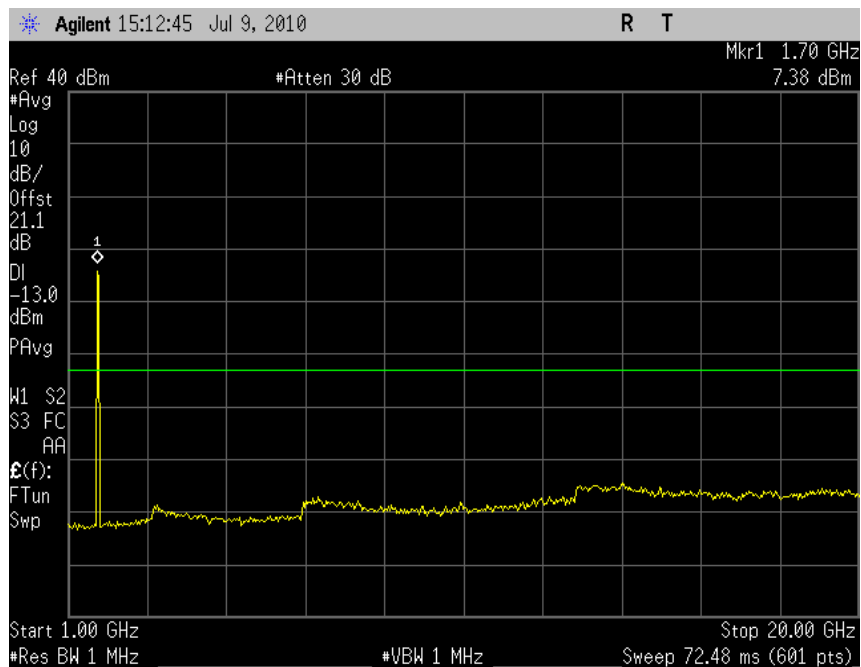

Plot 7.2 - 33 (Rel99, Ch1427)

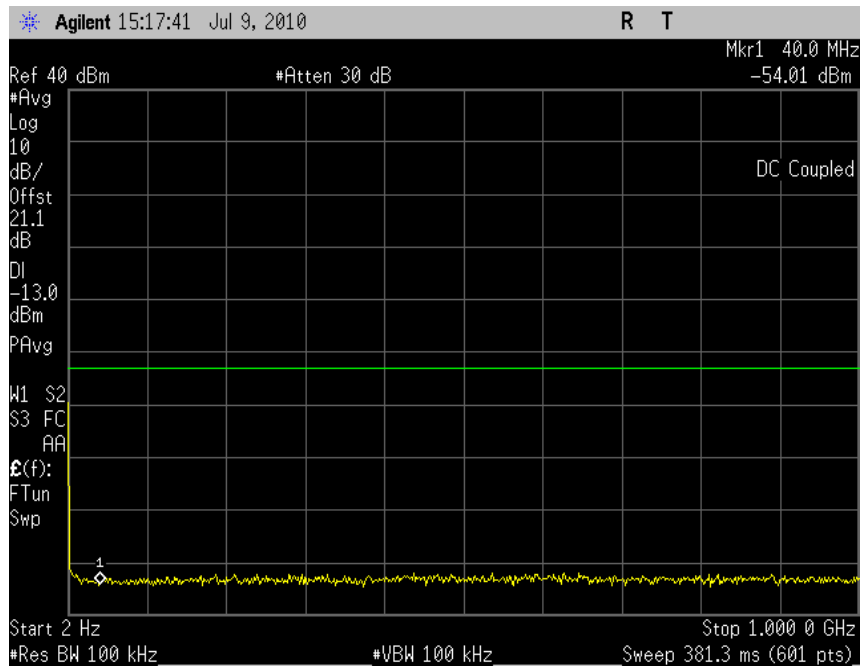

Plot 7.2 - 34 (Rel99, Ch1427)

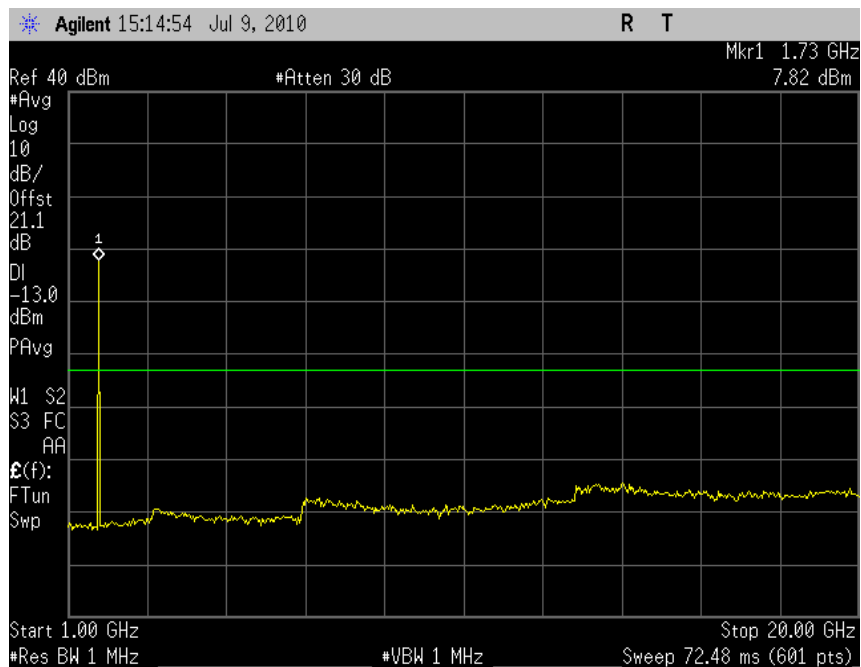

Plot 7.2 - 35 (Rel99, Ch1513)

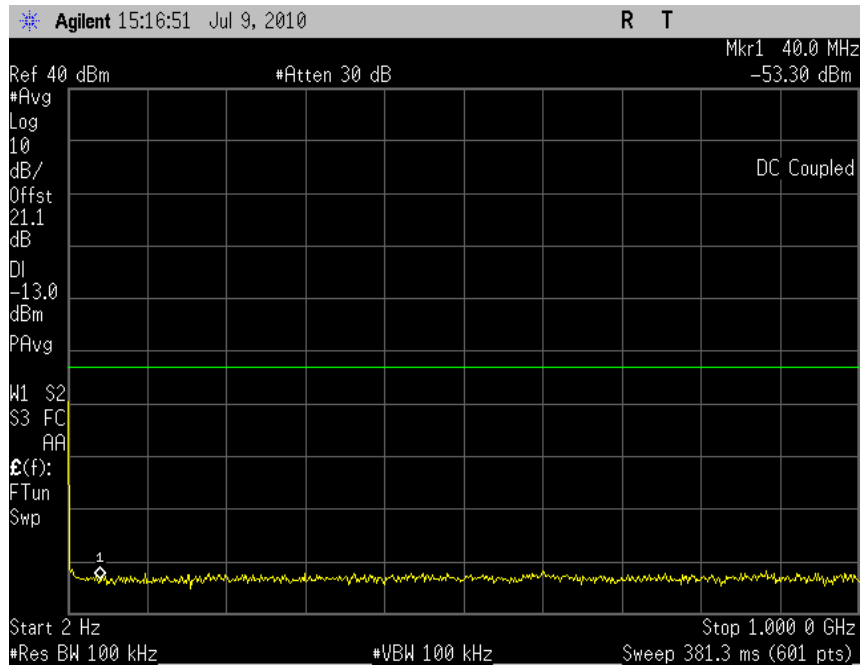

Plot 7.2 - 36 (Rel99, Ch1513)

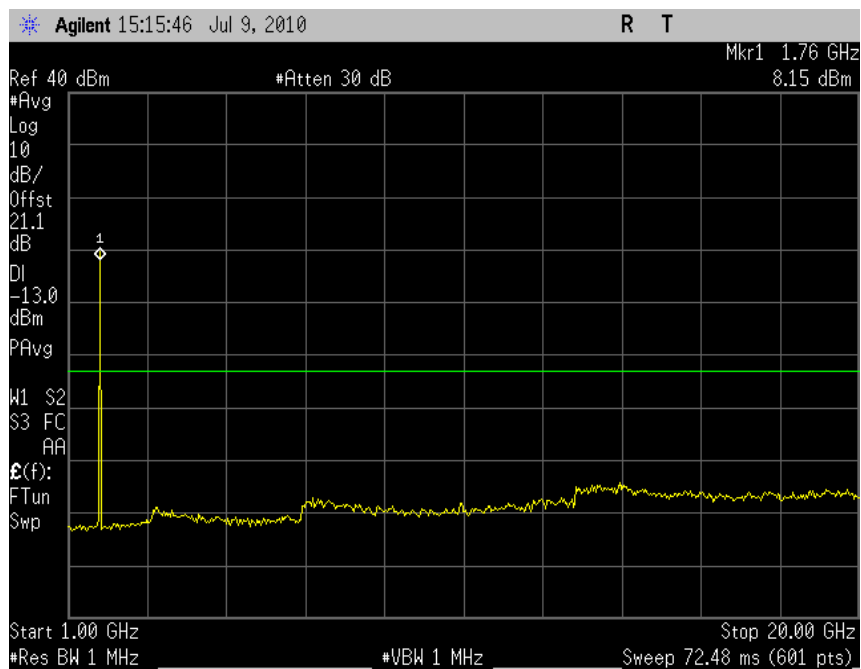

Plot 7.2 - 37 (Rel99, Ch9262)

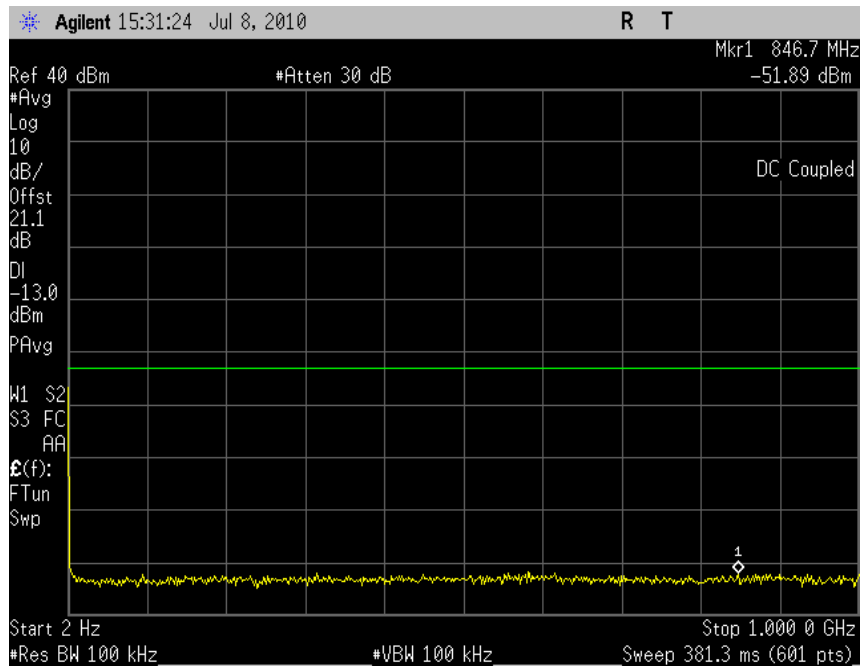

Plot 7.2 - 38 (Rel99, Ch9262)

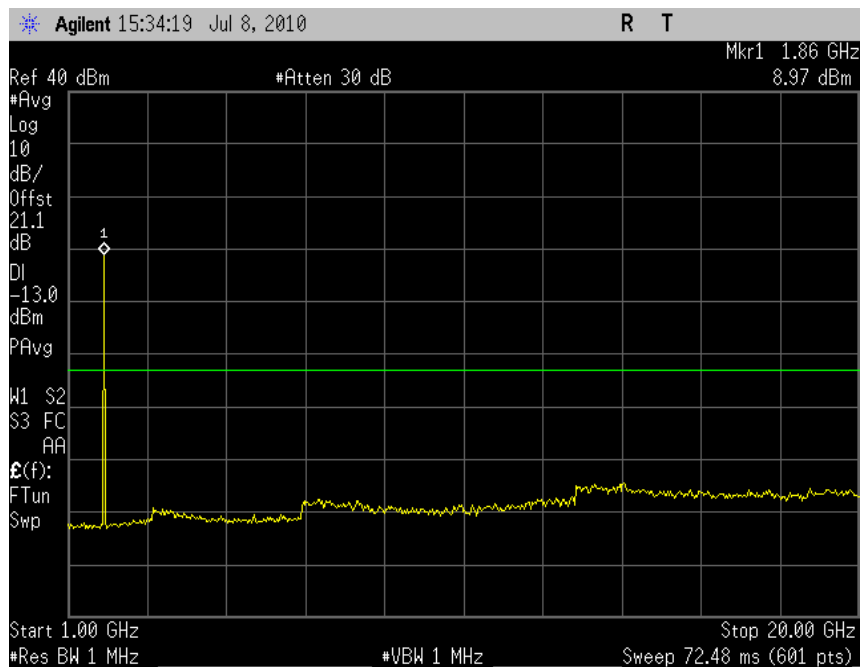

Plot 7.2 - 39 (Rel99, Ch9400)

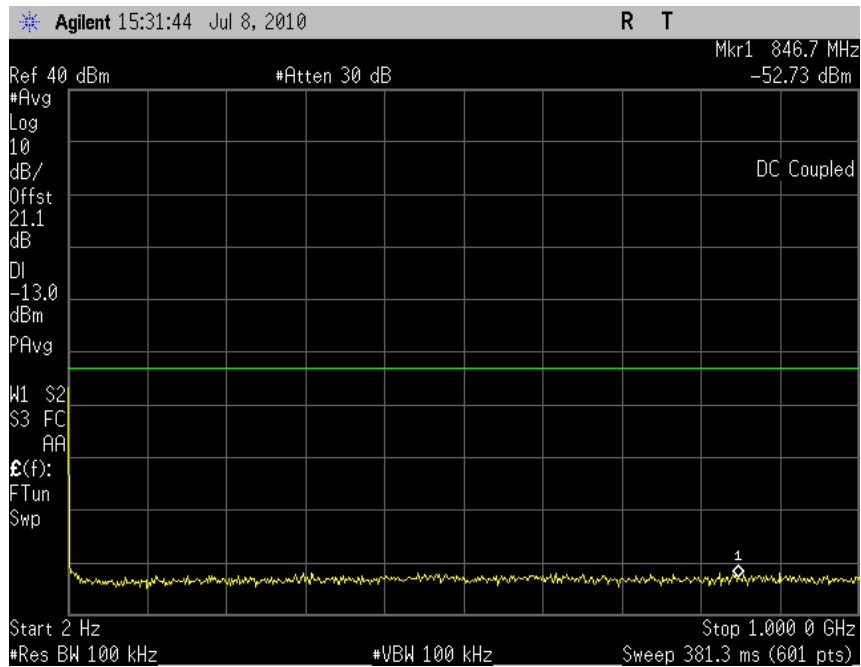

Plot 7.2 - 40 (Rel99, Ch9400)

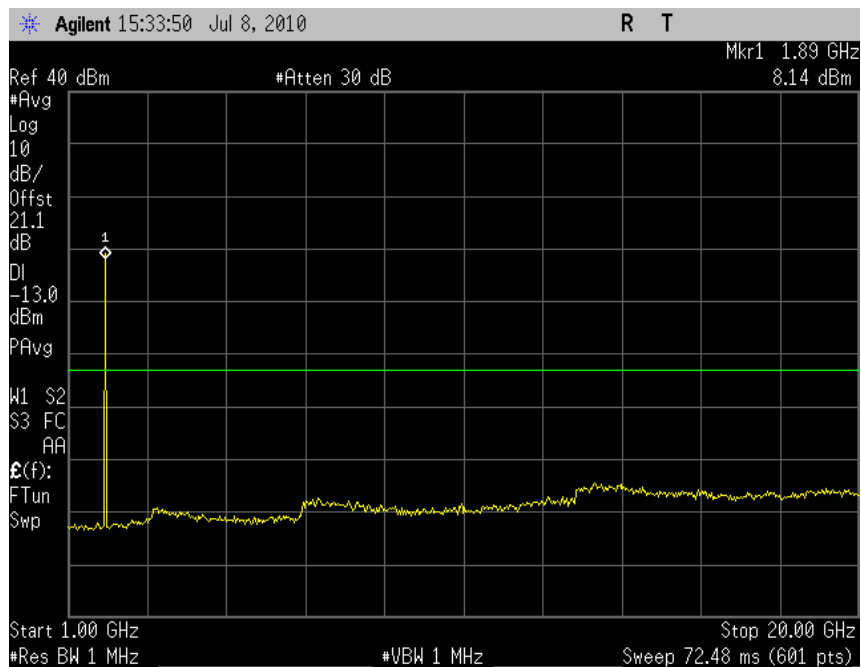

Plot 7.2 - 41 (Rel99, Ch9538)

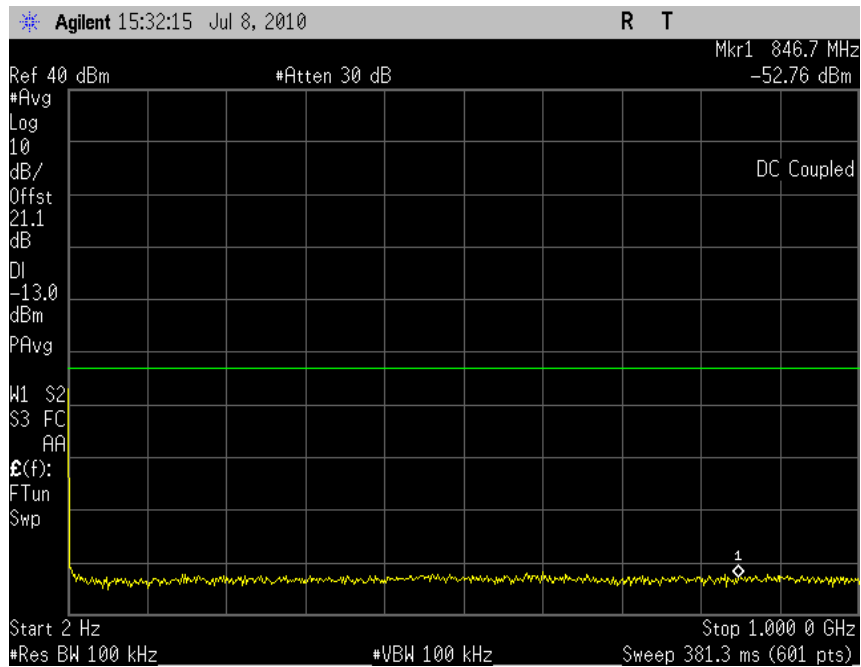

Plot 7.2 - 42 (Rel99, Ch9538)

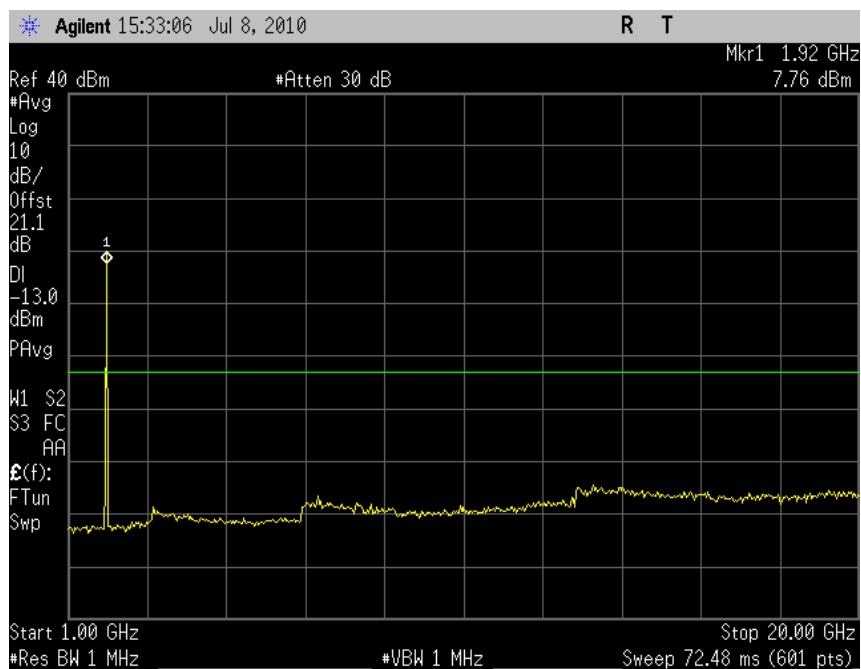

7.2.3 CDMA2000 Emissions Plots

Plot 7.2 -43 (EVDO, Rel 0, Ch. 1013)

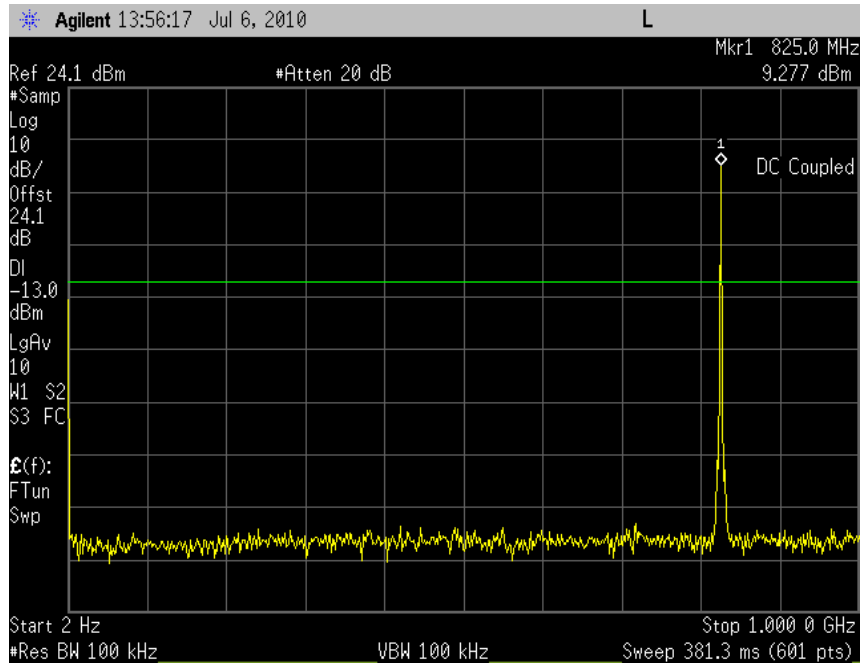

Plot 7.2 -44 (EVDO, Rel 0, Ch. 1013)

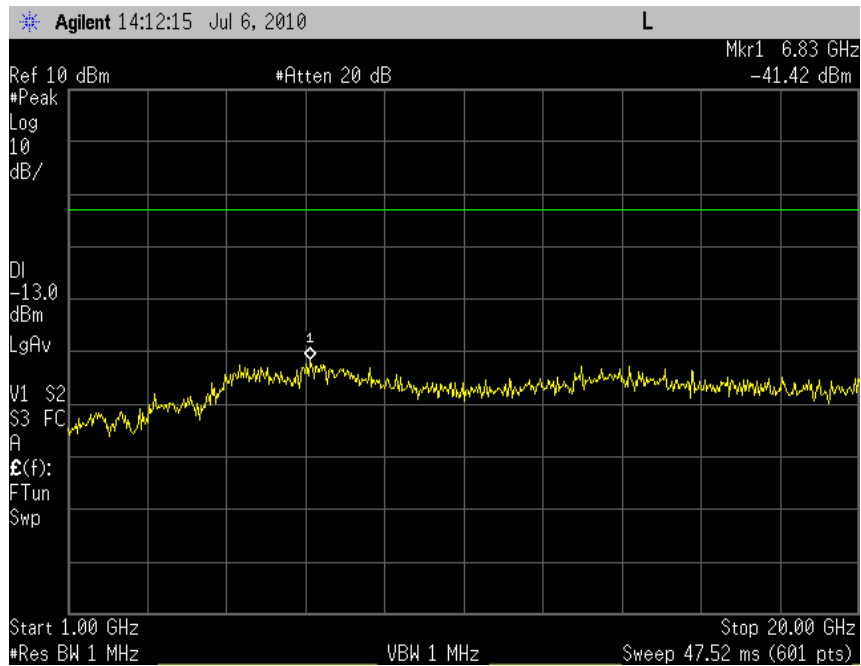

Plot 7.2 -45 (EVDO, Rel 0, Ch. 384)

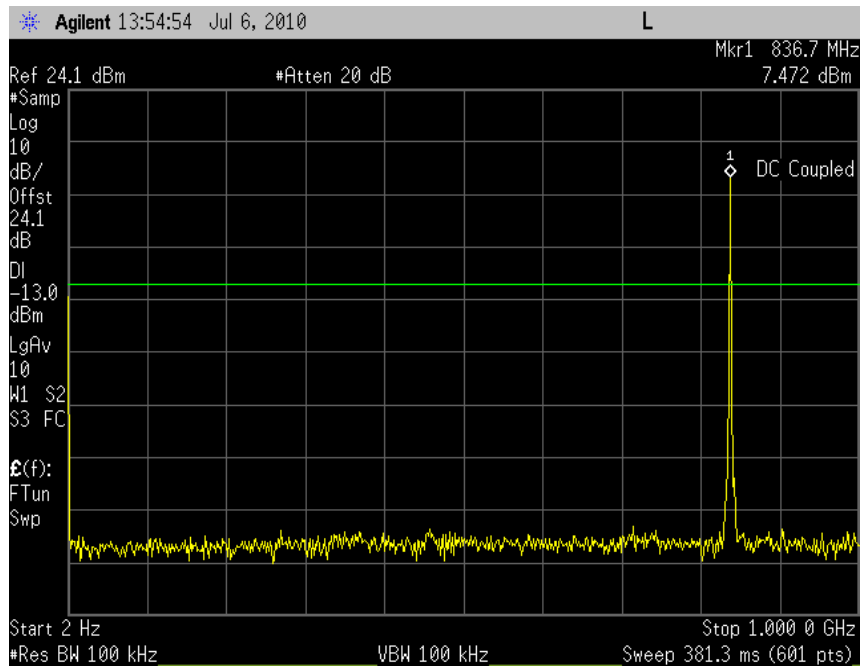

Plot 7.2 -46 (EVDO, Rel 0, Ch. 384)

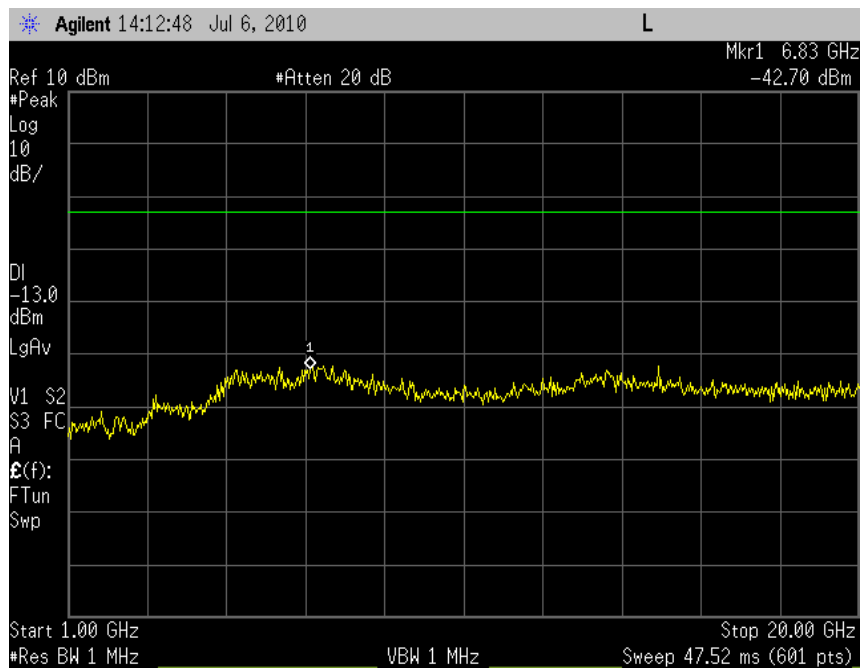

Plot 7.2 - 47 (EVDO, Rel 0, Ch. 777)

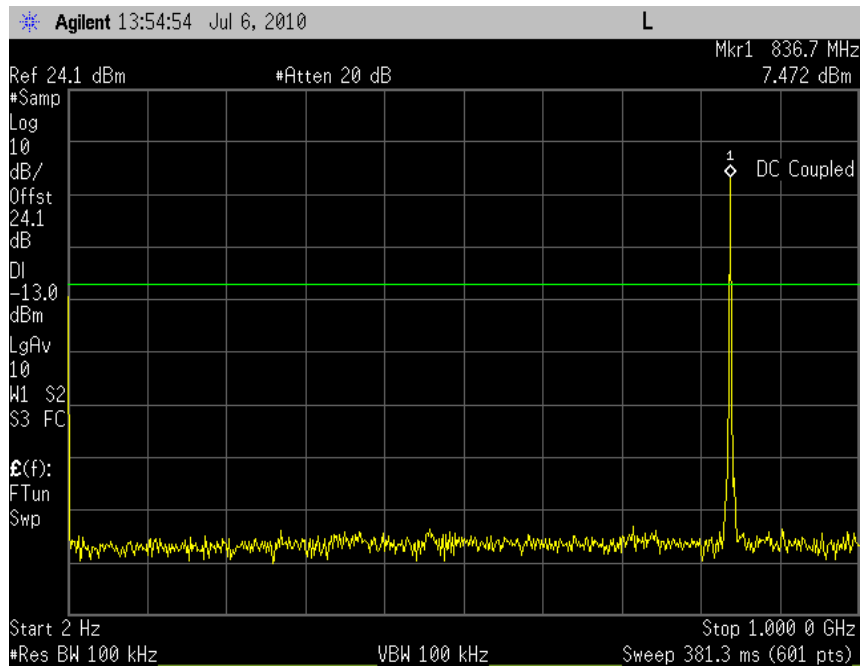

Plot 7.2 - 48 (EVDO, Rel 0, Ch. 777)

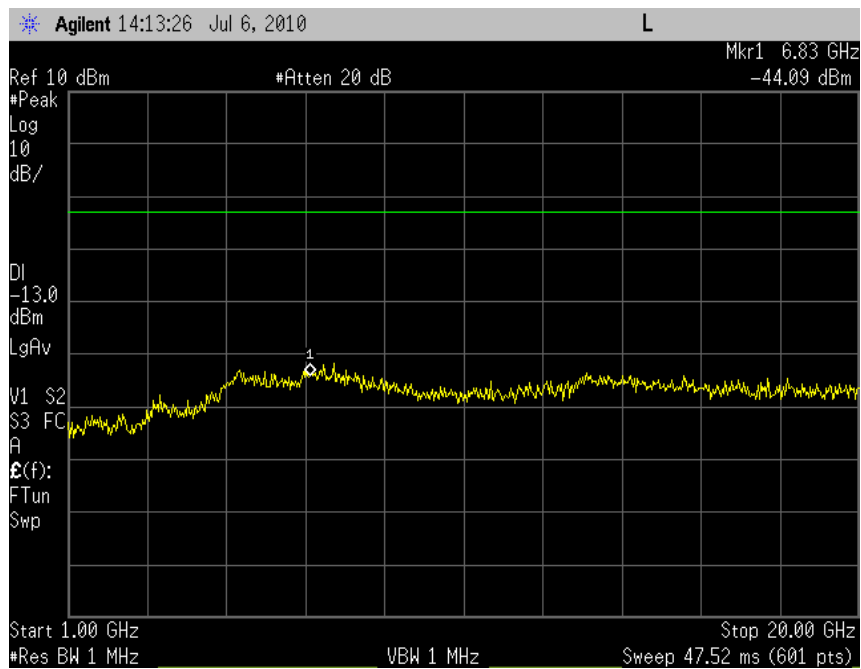

Plot 7.2 - 49 (EVDO, Rel 0, Ch. 25)

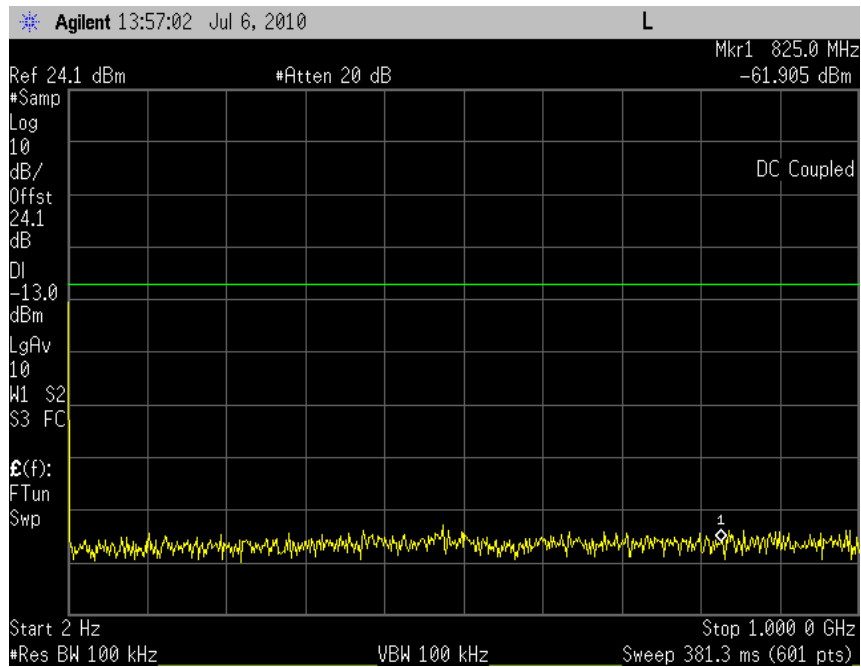

Plot 7.2 - 50 (EVDO, Rel 0, Ch. 25)

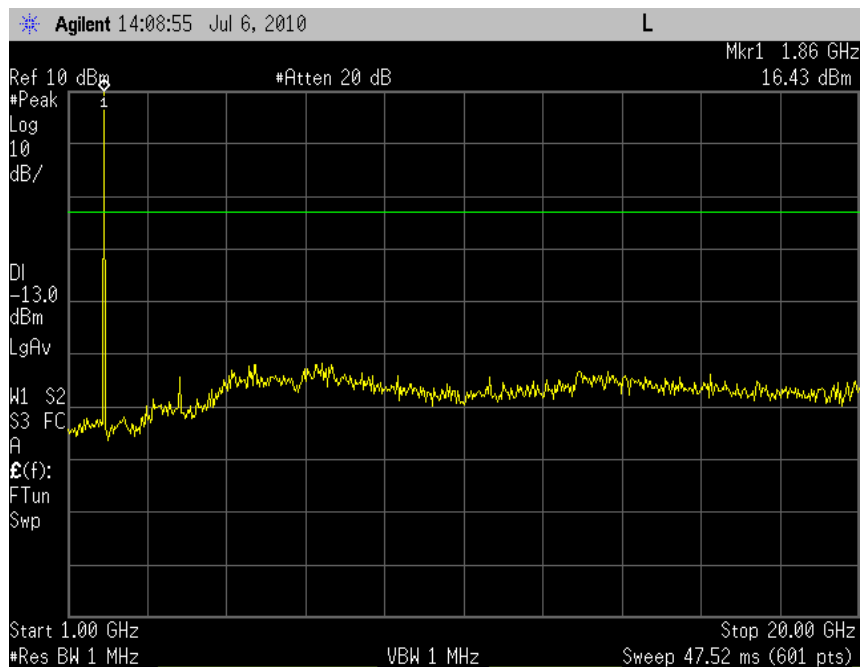

Plot 7.2 - 51 (EVDO, Rel 0, Ch. 600)

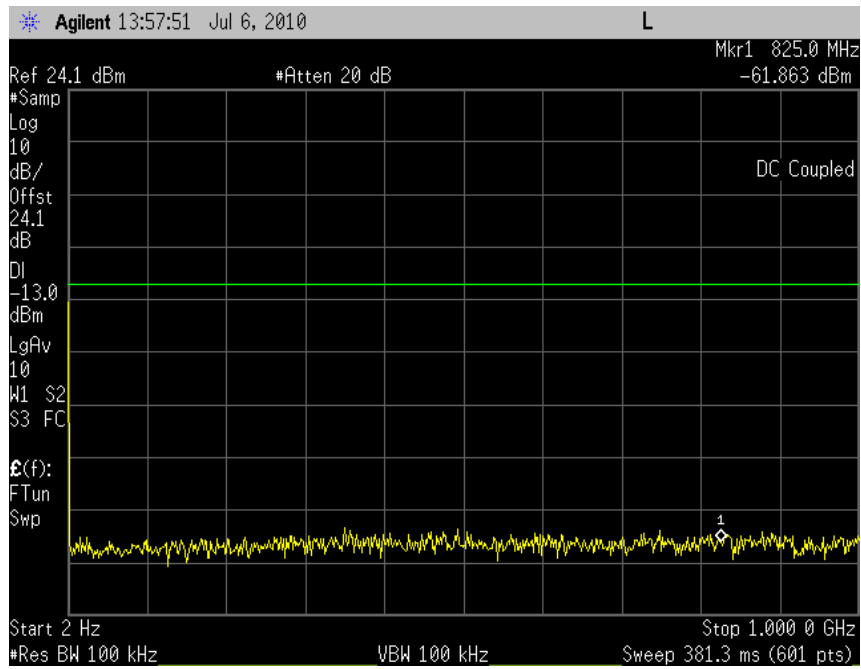

Plot 7.2 - 52 (EVDO, Rel 0, Ch. 600)

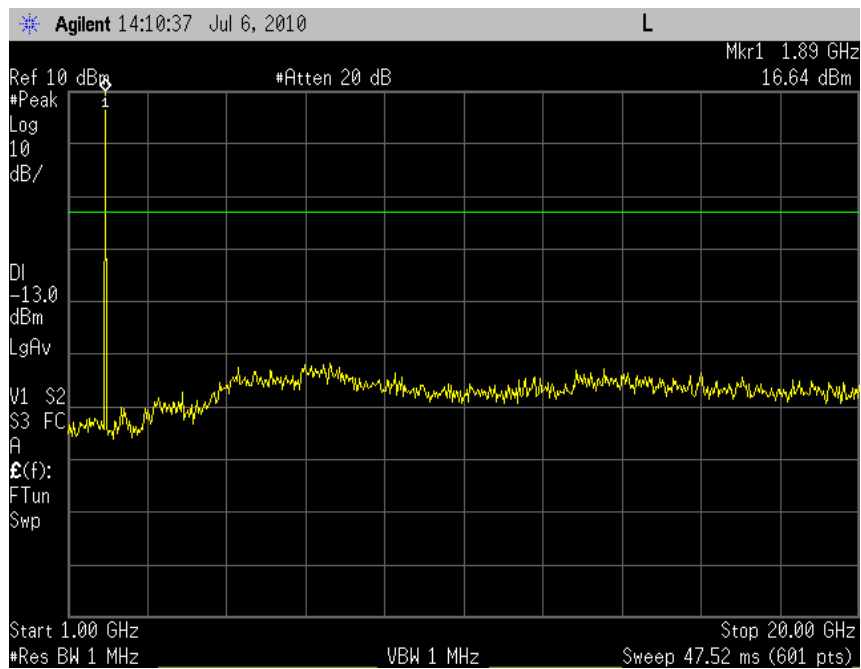

Plot 7.2 - 53 (EVDO, Rel 0, Ch. 1175)

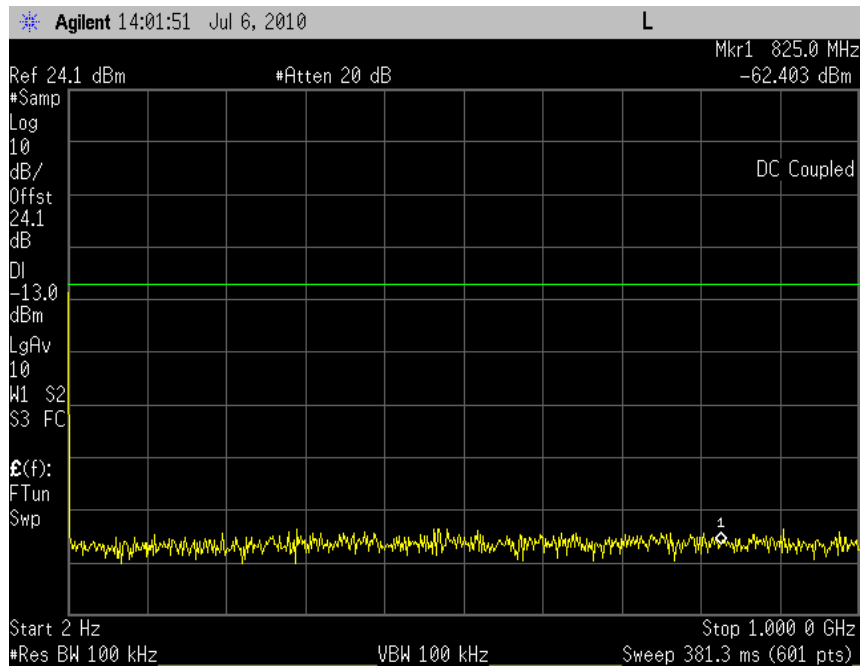

Plot 7.2 - 54 (EVDO, Rel 0, Ch. 1175)

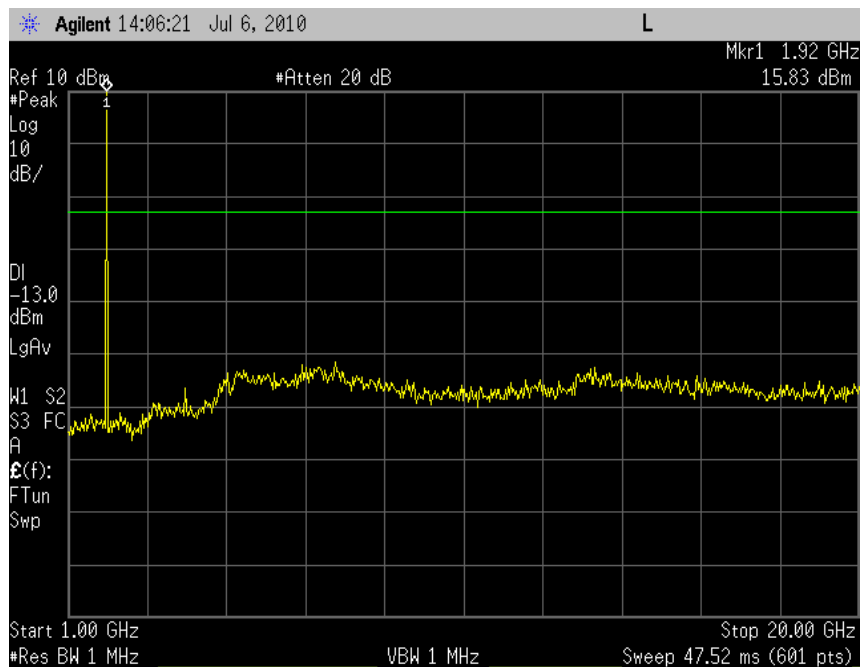

8. Frequency Stability

FCC:	§2.1055, 22.355, 24.235, 27.54		
Limit:	±2.5ppm		
DUT SN	N10F6TXR		
Modes Tested	CDMA 1x / 1x-EVDO	WCDMA/HSPA	GSM/GPRS/EDGE
	Rel 0, RTAP rate = 153.6kbps	Rel 99	GSM EDGE

8.1 Frequency Stability Test Procedure

As the test setup indicates, placed the Gobi3000 module inside the temperature chamber. Measured the transmitting frequency error at 20 degrees C with DC voltage varying from 3.0 volts to 3.6 volts, and then set the temperature to -30 degrees C and allow it to stabilize. After 1 hour soak time, take the measurement on transmitting frequency error at -30 degrees in the same manner. As an incremental of 10 degrees C, repeat the same process until +60 degrees C is completed.

An 8960 call box was used for CDMA 1x/1x-EVDO and UMTS testing.

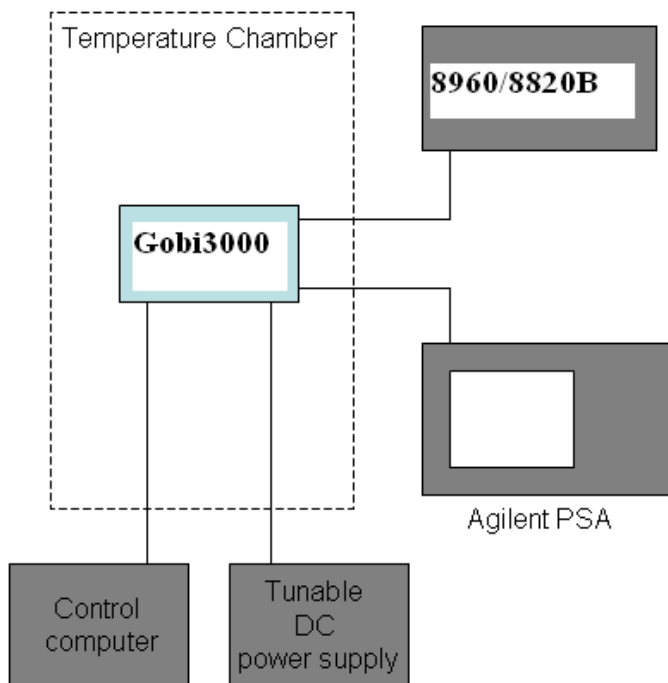

8.2 Frequency Stability Test Results

The test was conducted at mid channel in each band.

Operation Mode:	GMSK	Channel:	190
Tx Frequency:	836.6MHz	Voltage:	3.3v (3.0v ~ 3.6v)
Limit:	±2.5ppm (±2091Hz)		

Temperature (°C)	Deviation of Carrier (Hz)			Specification (Hz)	
	3.0V	3.3V	3.6V	Lower limit	Upper limit
-30	20.1	25.6	10.1	-2091	2091
-20	-16.6	-17.4	23.5	-2091	2091
-10	31.3	21.6	25.7	-2091	2091
0	11.2	-7.8	3.8	-2091	2091
10	-24.6	-8.6	36.1	-2091	2091
20	27.6	20.4	22.0	-2091	2091
24	-104.4	-33.2	-28.7	-2091	2091
30	-15.2	27.1	-25.3	-2091	2091
40	-46.5	-30.2	-23.4	-2091	2091
50	20.6	18.8	15.3	-2091	2091
60	-15.4	-16.2	-26.5	-2091	2091

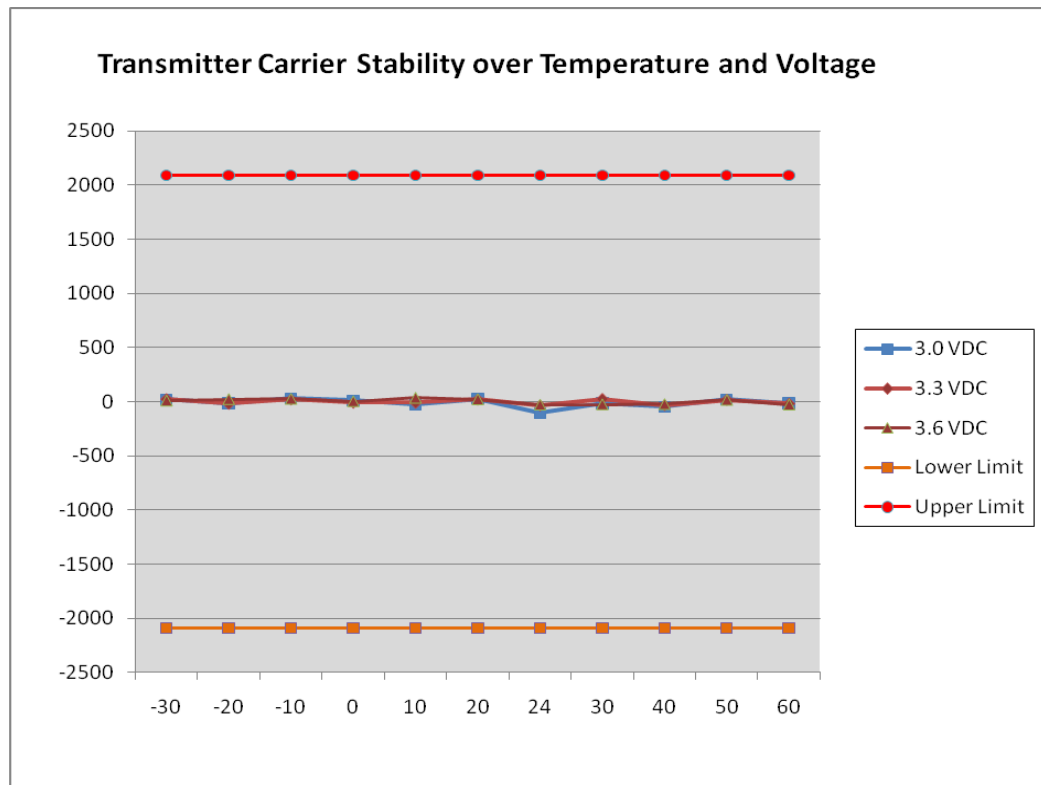

Operation Mode:	GMSK	Channel:	661
Tx Frequency:	1880MHz	Voltage:	3.3v (3.0v ~ 3.6v)
Limit:	±2.5ppm (±4700Hz)		

Temperature (°C)	Deviation of Carrier (Hz)			Specification (Hz)	
	3.0V	3.3V	3.6V	Lower limit	Upper limit
-30	40.7	48.2	56.6	-4700	4700
-20	37.5	60.1	63.7	-4700	4700
-10	59.7	41.1	64.1	-4700	4700
0	55.3	50.2	53.7	-4700	4700
10	-310.7	-5.1	25.1	-4700	4700
20	-16.1	-30.1	-29.3	-4700	4700
24	46.3	14.5	-18.4	-4700	4700
30	-15.4	-18.6	-16.5	-4700	4700
40	7.4	6.4	8.6	-4700	4700
50	6.4	-4.3	-17.1	-4700	4700
60	38.5	13.5	41.2	-4700	4700

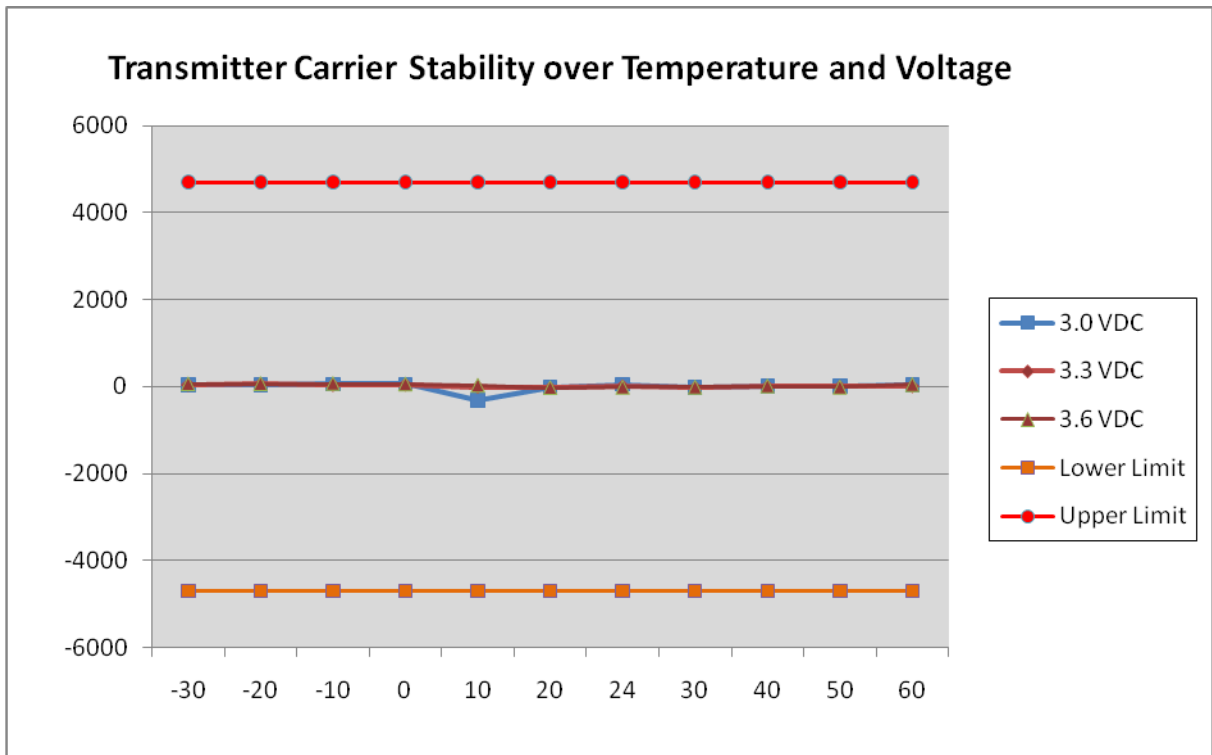

Operation Mode:	8PSK	Channel:	190
Tx Frequency:	836.6MHz	Voltage:	3.3v (3.0v ~ 3.6v)
Limit:	±2.5ppm (±2091Hz)		

Temperature (°C)	Deviation of Carrier (Hz)			Specification (Hz)	
	3.0V	3.3V	3.6V	Lower limit	Upper limit
-30	19.4	26.1	24.2	-2091	2091
-20	-14.3	-14.5	-6.7	-2091	2091
-10	18.6	17.3	21.4	-2091	2091
0	7.6	-14.2	11.2	-2091	2091
10	-169.7	-21.7	-14.4	-2091	2091
20	-11.2	-17.5	-20.4	-2091	2091
24	-23.2	-41.3	-32.5	-2091	2091
30	-15.8	-21.5	-28.5	-2091	2091
40	-11.8	-17.6	-27.4	-2091	2091
50	-9.6	-18.4	-16.2	-2091	2091
60	-13.4	-20.6	-10.8	-2091	2091

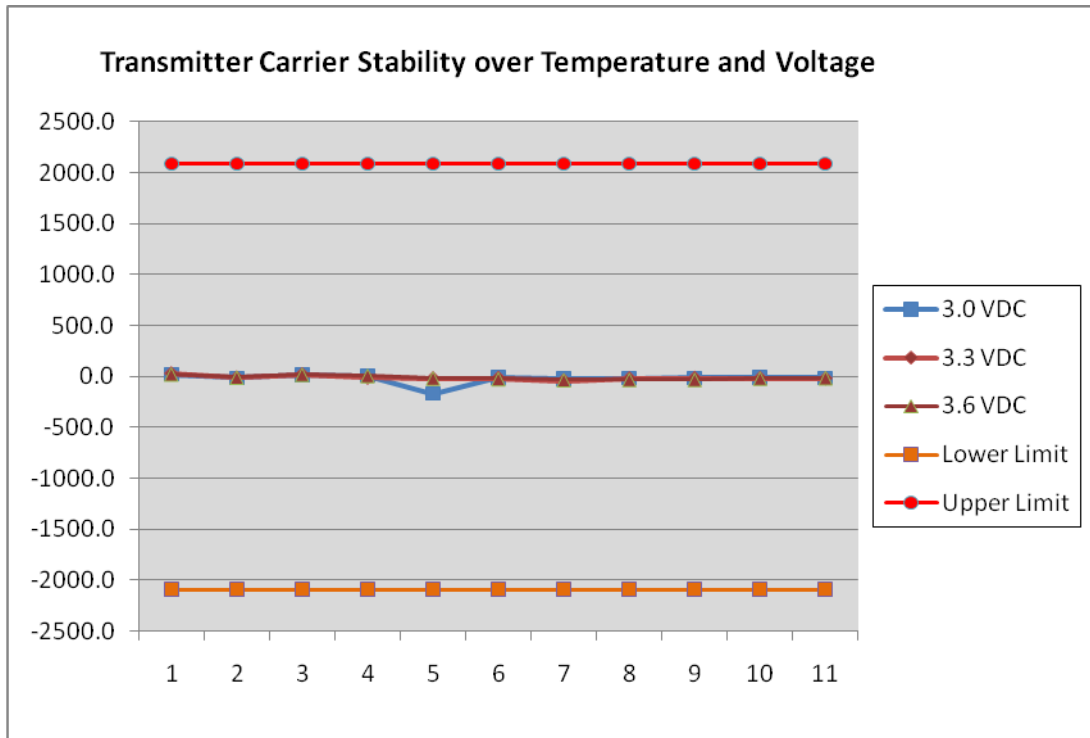

Operation Mode:	8PSK	Channel:	661
Tx Frequency:	1880MHz	Voltage:	3.3v (3.0v ~ 3.6v)
Limit:	±2.5ppm (±4700Hz)		

Temperature (°C)	Deviation of Carrier (Hz)			Specification (Hz)	
	3.0V	3.3V	3.6V	Lower limit	Upper limit
-30	7.4	24.7	30.2	-4700	4700
-20	20.9	33.6	40.2	-4700	4700
-10	50.2	67.4	61.1	-4700	4700
0	57.2	60.2	-46.3	-4700	4700
10	-304.6	29.2	23.2	-4700	4700
20	6.4	-11.5	-16.3	-4700	4700
24	14.4	25.7	8.8	-4700	4700
30	5.5	-8.4	-12.4	-4700	4700
40	12.6	-15.4	14.1	-4700	4700
50	-5.4	-8.8	-15.3	-4700	4700
60	21.5	21.4	17.1	-4700	4700

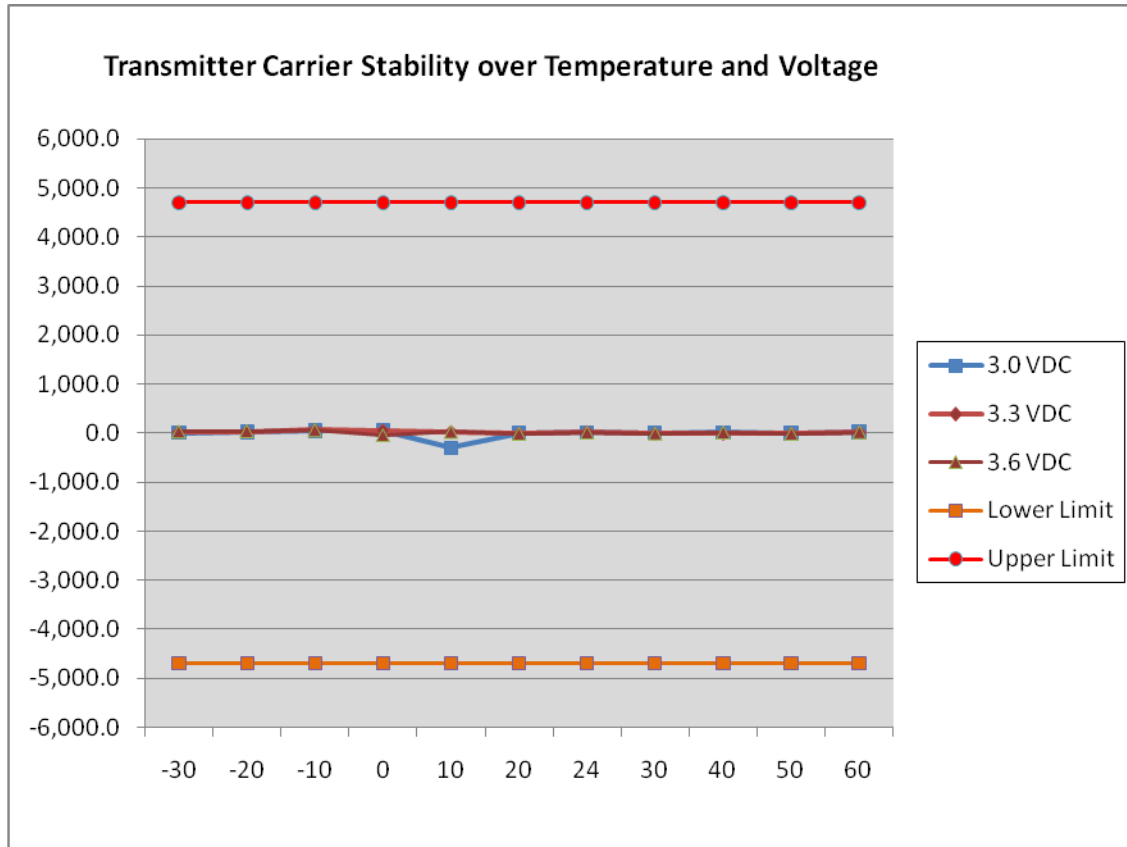

Operation Mode:	WCDMA Rel 99	Channel:	4182
Tx Frequency:	836.4MHz	Voltage:	3.3v (3.0v ~ 3.6v)
Limit:	±2.5ppm (±2091Hz)		

Temperature (°C)	Deviation of Carrier (Hz)			Specification (Hz)	
	3.0V	3.3V	3.6V	Lower limit	Upper limit
-30	-12.6	14.0	-11.8	-2091	2091
-20	-22.5	-12.7	-16.5	-2091	2091
-10	-10.6	-16.8	-8.4	-2091	2091
0	-13.4	-14.4	-12.5	-2091	2091
10	-29.3	-15.6	-12.2	-2091	2091
20	-14.5	-12.5	-15.3	-2091	2091
24	-8.8	9.6	9.5	-2091	2091
30	-21.9	-20.4	-15.3	-2091	2091
40	-15.3	-12.4	-11.9	-2091	2091
50	-11.0	-11.2	-13.8	-2091	2091
60	-12.5	-13.9	-14.8	-2091	2091

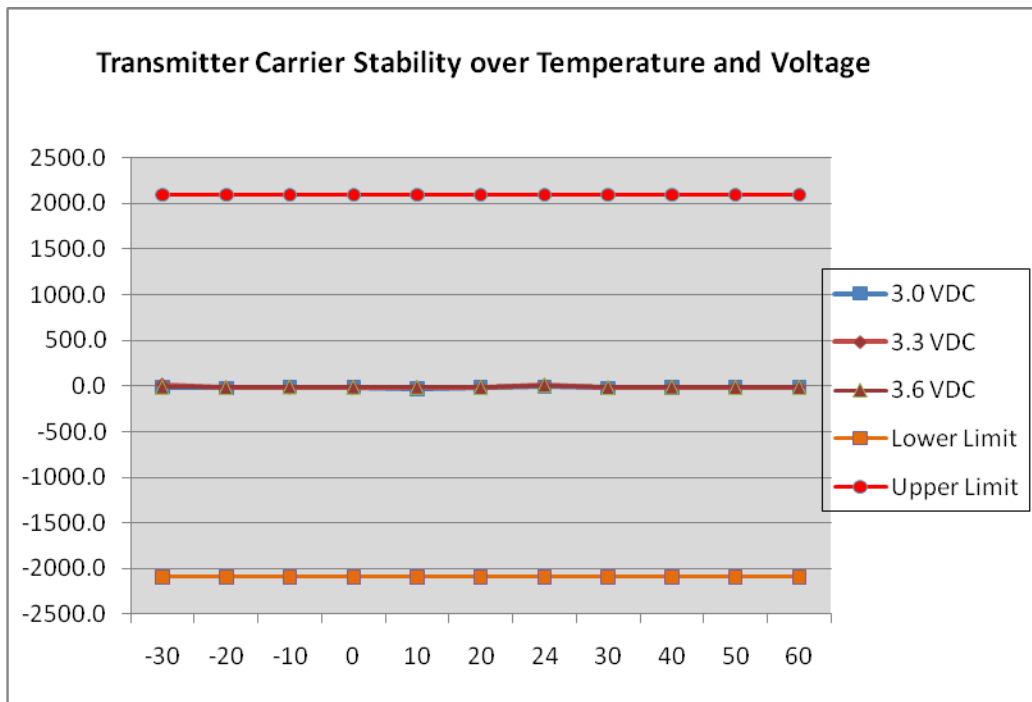

Operation Mode:	WCDMA Rel 99	Channel:	9400
Tx Frequency:	1880MHz	Voltage:	3.3v (3.0v ~ 3.6v)
Limit:	±2.5ppm (±4700Hz)		

Temperature (°C)	Deviation of Carrier (Hz)			Specification (Hz)	
	3.0V	3.3V	3.6V	Lower limit	Upper limit
-30	-36.3	-33.3	-21.7	-4700	4700
-20	24.7	17.1	30.6	-4700	4700
-10	25.3	32.6	20.3	-4700	4700
0	-16.1	13.9	-27.2	-4700	4700
10	-33.5	28.4	23.4	-4700	4700
20	25.4	-23.8	-23.8	-4700	4700
24	23.1	18.8	11.6	-4700	4700
30	25.6	23.6	21.8	-4700	4700
40	-22.9	18.1	-17.8	-4700	4700
50	25.9	19.9	-17.2	-4700	4700
60	-18.4	-21.8	20.5	-4700	4700

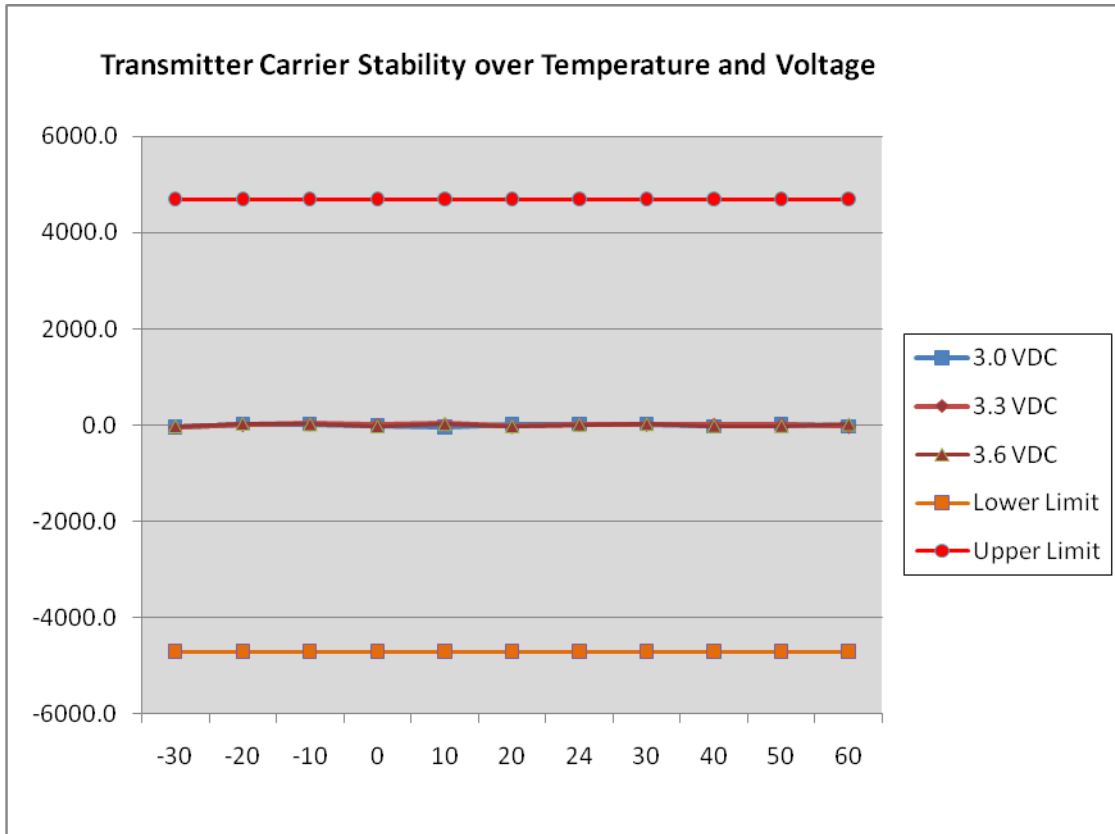

Operation Mode:	WCDMA Rel 99	Channel:	1427
Tx Frequency:	1880MHz	Voltage:	3.3v (3.0v ~ 3.6v)
Limit:	±2.5ppm (±4700Hz)		

Temperature (°C)	Deviation of Carrier (Hz)			Specification (Hz)	
	3.0V	3.3V	3.6V	Lower limit	Upper limit
-30	24.5	29.0	18.7	-4700	4700
-20	18.5	22.3	-17.8	-4700	4700
-10	27.8	26.1	25.2	-4700	4700
0	25.1	23.3	15.0	-4700	4700
10	-51.9	22.7	16.1	-4700	4700
20	-31.2	-20.1	-22.3	-4700	4700
24	-13.9	-19.3	16.3	-4700	4700
30	-22.4	15.7	16.1	-4700	4700
40	-19.6	22.5	17.7	-4700	4700
50	-22.9	-20.5	-21.4	-4700	4700
60	-20.6	-22.5	-22.4	-4700	4700

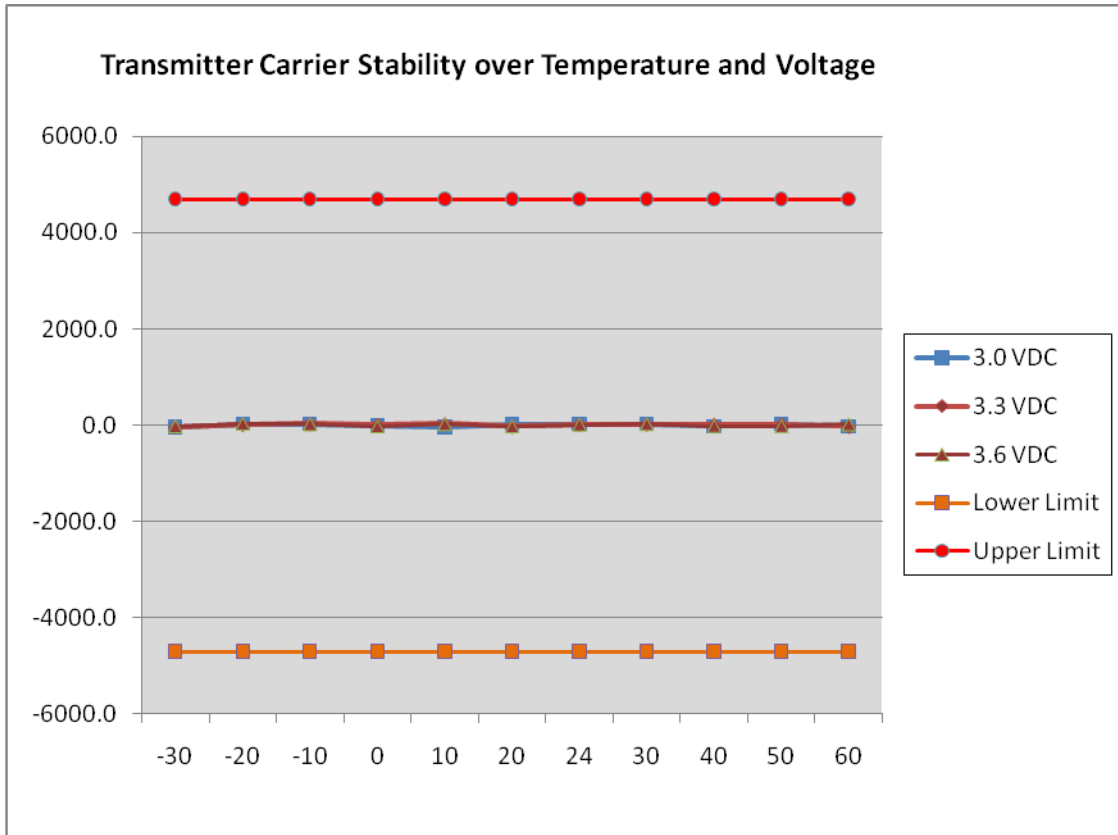

Operation Mode:	EVDO, Rel 0, RTAP rate = 153.6kbps	Channel:	384
Tx Frequency:	836.52MHz	Voltage:	3.3v (3.0v ~ 3.6v)
Limit:	±2.5ppm (±2091Hz)		

Temperature (°C)	Deviation of Carrier (Hz)			Specification (Hz)	
	3.0V	3.3V	3.6V	Lower limit	Upper limit
-30	6.9	6.4	6.5	2091	-2091
-20	-7.3	-7.5	-6.4	2091	-2091
-10	-7.1	-7.4	-6.8	2091	-2091
0	7	7.3	-8.7	2091	-2091
10	-4.7	7.8	9.3	2091	-2091
20	9.2	-7.1	-6.8	2091	-2091
24	3.1	1.9	3.2	2091	-2091
30	9.5	10.6	-4.4	2091	-2091
40	-9.8	11.1	-5.9	2091	-2091
50	11.8	10.2	10.0	2091	-2091
60	11.3	-10.1	8.8	2091	-2091

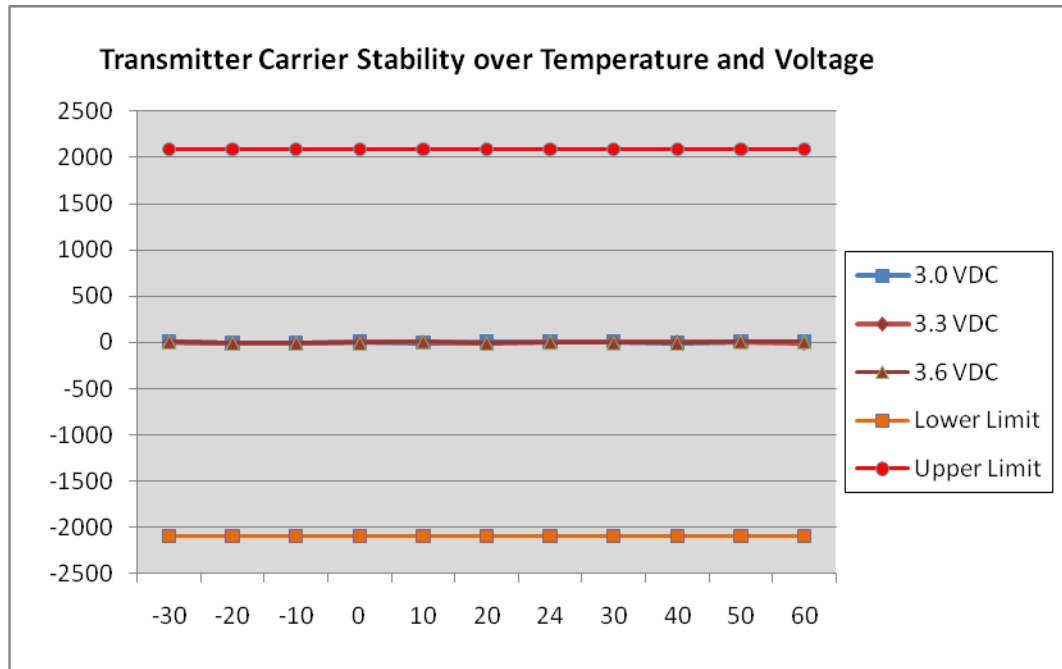

Operation Mode:	EVDO, Rel 0, RTAP rate = 153.6kbps	Channel:	600
Tx Frequency:	1880MHz	Voltage:	3.3v (3.0v ~ 3.6v)
Limit:	±2.5ppm (±4700Hz)		

Temperature (°C)	Deviation of Carrier (Hz)			Specification (Hz)	
	3.0V	3.3V	3.6V	Lower limit	Upper limit
-30	4.6	4.2	4.9	-4700	4700
-20	-7.8	-6.5	3.1	-4700	4700
-10	7.5	7.1	6.3	-4700	4700
0	5.8	6.4	5.3	-4700	4700
10	7.0	4.9	-4.6	-4700	4700
20	-12.6	-5.2	-3.9	-4700	4700
24	-1.8	-1.2	-1.5	-4700	4700
30	4.9	5.6	2.6	-4700	4700
40	-2.8	-2.5	-2.6	-4700	4700
50	-21.0	5.2	4.1	-4700	4700
60	-6.1	-4.5	-5.0	-4700	4700

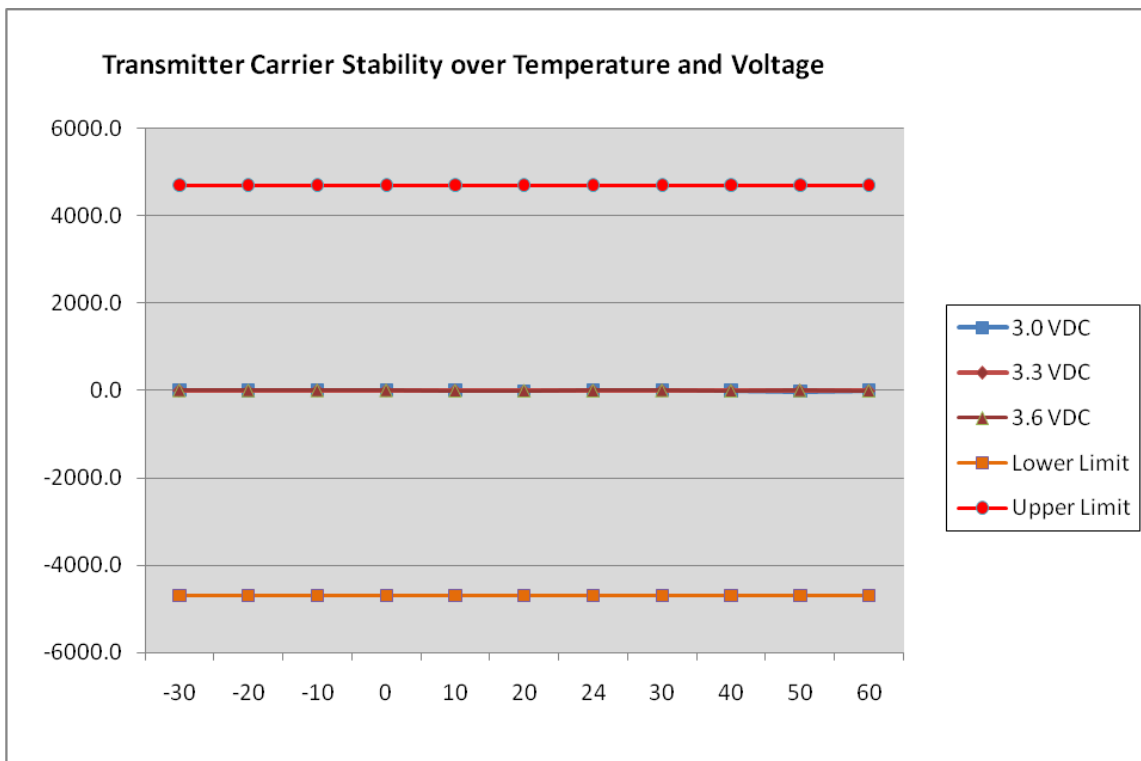

9. Test Equipment and Firmware

The following test equipments were used.

Model	Manufacturer	Description	S/N	Cal Date	Cal Due Date
8960 Series 10 E5515C	Agilent	Wireless Communication Set	K119302	9/16/2009	09/16/2010
E4440A PSA Series	Agilent	Spectrum Analyzer	K159342	9/15/2009	9/15/2010
Compaq 6910p	Hewlett Packard	Notebook Computer	P116464	N/R	N/R
Model 105	TestEquity	Temperature Chamber	K162535	09/22/2009	09/22/2010
50-VD628-1 Rev A/A	Qualcomm	Module Fixture	N10F76FMN	N/R	N/R

The firmwares built in the 8960 and 8820B are as follows, and have been validated to support the testing for all technologies implemented in GOBI3000.

Call Box	Technology	Firmware Rev
8960	EVDO	A.07.21
	1x	B.12.21
	UMTS	A.09.21