

User Manual

Model number: WR3200

WI-FI RF FREQUENCY BANDS AND PERFORMANCE

The Module shall be compliant with the 802.11n (2.4GHz band) and 802.11ac (5GHz band) Wi-Fi standards.

The Module shall be compliant with the 802.11ax (2.4GHz band and 5GHz band) Wi-Fi standard.

The Module shall cover an unobstructed indoor range of Vertical 15M and Horizontal 50M.

Wi-Fi Software Functions

Category	Feature	Description
NAT/NAPT	NAT mode	Port Forwarding and DMZ hosting support
Firewall Security	Stateful Packet Inspection (SPI)/ Denial of Service (DOS)	
	MAC Address Filter	
	URL Filtering	
	PPTP/IPsec pass-through	Allows telecommuters to access their corporate network without being concerned about the issue of Virtual Private Networks running in an IP sharing network.
	Support uPnP	Universal Plug and Play
	Static IP	One address shall be configured with 192.168.0.254/24. This IP address is used by the satellite modem for control/management.
WAN IP Address Assignment	DHCP	The second address shall be obtained via DHCP and provide support to renewal of this address on demand (when triggered by Modem). The following protocols shall be supported: - DHCPv4 client - DHCPv6-PD client - Stateless IPv6 Auto-configuration - Stateless DHCPv6 client for DNS server
Network	IP Multicast: IGMP v2/IGMP snooping	
	DDNS Client	DynDNS.org
	SIP NAT Traversal	
	Support ALG (Application Layer Gateway)	Vendor to provide details of what is supported in their ALG
	Web UI Interface	Full web-based interface with login authentication for users to configure and view status of . Accessible via all Ethernet ports as well as Wi-Fi. The Module cannot use the 192.168.0.x subnet as that is reserved for use by the Satellite modem. At a minimum, the Wi-Fi shall allow a user to configure the following from the local web user interface: - NAT/NAPT inbound port mapping - MAC/device IP address reservation - MAC address whitelist - SSID name(s) and security passphrase - Guest Wi-Fi enable/disable
	Network Time Protocol	System time can be synchronized automatically with time server located in the Internet or with the local computer.
	Remote Management	Allows administrators to manage the device from anywhere at any time via the WAN interface.
Active Queue Management	Intelligent drop of network packets inside a buffer associated with a NIC. Built-in AQM solutions to ensure good performance, even in the presence of bursty satellite traffic and multiple devices with varying link conditions. Kernel support for configuring & running, when needed, AQM algorithms like FQ-Codel, Robust RED, Stochastic Fair Blue, PI, etc.	

Report product info	Report product info for final test	Report: S/N, MAC address, Setup info, chipset lot info, calibration.
	Report product statistics	Collect periodic PHY/L2/L3 stats per radio, per VAP, and per connected device and report to the satellite modem.
Remote debug	Remote debug via Satellite modem or cell phone connected in the Wi-Fi network	Report Error conditions; and accept remote debug and update via Satellite Modem or cell phone connected to the Wi-Fi network.

Setup SOP:

- EUT LAN IP : 192.168.42.1
- EUT WiFi 2.4G SSID : HUGHES_24G
- EUT WiFi 5G SSID : HUGHES_5G

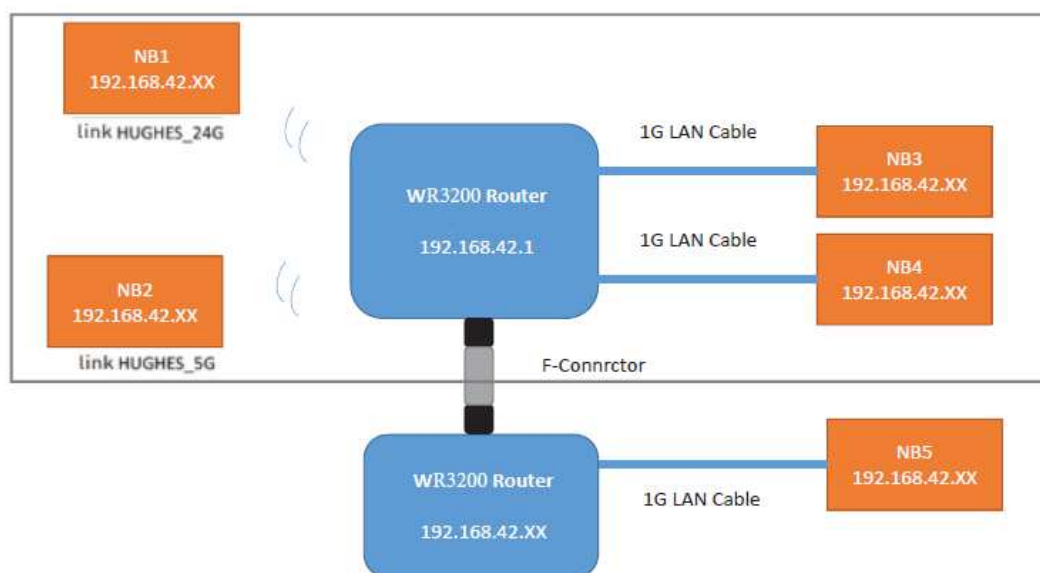

1. The is currently connected to the Test Board(simulation of end-product), please connect the Test Board to the Adapter to power on the EUT
2. Set NB1 WiFi IP to 192.168.42.x1, and connect to module 2.4G SSID through WiFi function (connection password: xxxxxxxx)
3. Set the NB2 WiFi IP to 192.168.42.x2, and connect to the SSID of module 5G through the WiFi function (connection password: xxxxxxxx)
4. Set the NB3 LAN IP to 192.168.42.x3, and connect to the Ethernet port on the module mainboard via RJ45 cable
5. Set the NB4 LAN IP to 192.168.42.x4, and connect to the Ethernet port on the module mainboard via RJ45 cable
6. After NB1~NB4 are all connected to EUT, all NBs can continue to ping module IP (192.168.42.x).

Federal Communication Commission Interference Statement

This device complies with Part 15 of the FCC Rules. Operation is subject to the following two conditions: (1) This device may not cause harmful interference, and (2) this device must accept any interference received, including interference that may cause undesired operation.

This equipment has been tested and found to comply with the limits for a Class B digital device, pursuant to Part 15 of the FCC Rules. These limits are designed to provide reasonable protection against harmful interference in a residential installation. This equipment generates, uses and can radiate radio frequency energy and, if not installed and used in accordance with the instructions, may cause harmful interference to radio communications. However, there is no guarantee that interference will not occur in a particular installation. If this equipment does cause harmful interference to radio or television reception, which can be determined by turning the equipment off and on, the user is encouraged to try to correct the interference by one of the following measures:

- Reorient or relocate the receiving antenna.
- Increase the separation between the equipment and receiver.
- Connect the equipment into an outlet on a circuit different from that to which the receiver is connected.
- Consult the dealer or an experienced radio/TV technician for help.

FCC Caution: Any changes or modifications not expressly approved by the party responsible for compliance could void the user's authority to operate this equipment.

This transmitter must not be co-located or operating in conjunction with any other antenna or transmitter.

Operations in the 5.15-5.25GHz band are restricted to indoor usage only. This device meets all the other requirements specified in Part 15E, Section 15.407 of the FCC Rules.

Radiation Exposure Statement:

This equipment complies with FCC radiation exposure limits set forth for an uncontrolled environment. This equipment should be installed and operated with minimum distance 20cm between the radiator & your body.

This module is intended for OEM integrators only. Per FCC KDB 996369 D03 OEM Manual v01 guidance, the following conditions must be strictly followed when using this certified module:

KDB 996369 D03 OEM Manual v01 rule sections:

2.2 List of applicable FCC rules

This module has been tested for compliance to FCC Part 15C and 15E,

2.3 Summarize the specific operational use conditions

The module is tested for standalone mobile RF exposure use condition. Any other usage conditions such as co-location with other transmitter(s) or being used in a portable condition will need a separate reassessment through a class II permissive change application or new certification.

Host product must be for indoor usage only.

2.4 Limited module procedures

Not applicable.

2.5 Trace antenna designs

Not applicable.

2.6 RF exposure considerations

This equipment complies with FCC mobile radiation exposure limits set forth for an uncontrolled environment. This equipment should be installed and operated with a minimum distance of 20cm between the radiator & your body. If the module is installed in a portable host, a separate SAR evaluation is required to confirm compliance with relevant FCC portable RF exposure rules.

2.7 Antennas

The following antennas have been certified for use with this module; antennas of the

same type with equal gain may also be used with this module. The antenna must be installed such that 20 cm can be maintained between the antenna and users.

Lower gain antennas are not permitted without C2PC for devices with radar detection.

Antenna Type	Dipole
Antenna connector	i-pex(MHF)

2.8 Label and compliance information

The final end product must be labeled in a visible area with the following: “Contains FCC ID: **RAXWR3200**”. The grantee's FCC ID can be used only when all FCC compliance requirements are met.

2.9 Information on test modes and additional testing requirements

This transmitter is tested in a standalone mobile RF exposure condition and any co-located or simultaneous transmission with other transmitter(s) or portable use will require a separate class II permissive change re-evaluation or new certification.

2.10 Additional testing, Part 15 Subpart B disclaimer

This transmitter module is tested as a subsystem and its certification does not cover the FCC Part 15 Subpart B (unintentional radiator) rule requirement applicable to the final host. The final host will still need to be reassessed for compliance to this portion of rule requirements if applicable.

As long as all conditions above are met, further transmitter test will not be required. However, the OEM integrator is still responsible for testing their end-product for any additional compliance requirements required with this module installed.

IMPORTANT NOTE: In the event that these conditions can not be met (for example certain laptop configurations or co-location with another transmitter), then the FCC authorization is no longer considered valid and the FCC ID can not be used on the final product. In these circumstances, the OEM integrator will be responsible for re-evaluating the end product (including the transmitter) and obtaining a separate FCC authorization.

Manual Information To the End User

The OEM integrator has to be aware not to provide information to the end user regarding how to install or remove this RF module in the user's manual of the end product which integrates this module.

The end user manual shall include all required regulatory information/warning as show in this manual.

OEM/Host manufacturer responsibilities

OEM/Host manufacturers are ultimately responsible for the compliance of the Host and Module. The final product must be reassessed against all the essential requirements of the FCC rule such as FCC Part 15 Subpart B before it can be placed on the US market. This includes reassessing the transmitter module for compliance with the Radio and EMF essential requirements of the FCC rules. This module must not be incorporated into any other device or system without retesting for compliance as multi-radio and combined equipment

Antenna list:

Set 1. WG622221-HS :

Frequency (MHz)	Chain 0 (5G3)		Chain 1 (5G6)	
	Gain(Max) dBi	Gain(Min) dBi	Gain(Max) dBi	Gain(Min) dBi
5150~5250MHz	2.5	1.8	3.0	2.8
5250~5350MHz	1.8	1.5	2.9	2.5
5470~5725MHz	1.7	1.5	2.7	2.5
5725~5850MHz	1.8	1.6	2.7	2.1

Antenna Spec

ANT set	RF Chain	Model	Gain (Max) dBi	Gain (Min) dBi	Frequency range(MHz)	Antenna Type	Connecter Type	Cable Length (mm)
1	0	WG622221-HS	1.9	1.2	2.4~2.4835	Dipole	i-pex(MHF)	60
	1	WG622221-HS	2.1	1.7	2.4~2.4835	Dipole	i-pex(MHF)	70
	0	WG622221-HS	2.5	1.5	5.15~5.85	Dipole	i-pex(MHF)	40
	1	WG622221-HS	3.0	2.1	5.15~5.85	Dipole	i-pex(MHF)	41

Antenna Location :

ANT set 1 :

