



FCC RADIO TEST REPORT

FCC ID : RAXG3100
Equipment : Fios Home Router, Fios Business Router
Brand Name : Verizon
Model Name : G3100
Applicant : Arcadyan Technology Corporation
No.8, Sec.2, Guangfu Rd.,Hsinchu, 30071 Taiwan
Manufacturer : Arcadyan Technology Corporation
No.8, Sec.2, Guangfu Rd.,Hsinchu, 30071 Taiwan
Standard : 47 CFR FCC Part 15 Subpart C § 15.249

The product was received on Apr. 01, 2019, and testing was started from Apr. 02, 2019 and completed on Jun. 04, 2019. We, SPORTON INTERNATIONAL INC. EMC & Wireless Communications Laboratory, would like to declare that the tested sample has been evaluated in accordance with the procedures given in ANSI C63.10-2013, 47 CFR FCC Part 15 Subpart C and shown compliance with the applicable technical standards.

The report must not be used by the client to claim product certification, approval, or endorsement by TAF or any agency of government.

The test results in this report apply exclusively to the tested model / sample. Without written approval of SPORTON INTERNATIONAL INC. EMC & Wireless Communications Laboratory, the test report shall not be reproduced except in full.

Approved by: Sam Chen

SPORTON INTERNATIONAL INC. EMC & Wireless Communications Laboratory
No. 52, Huaya 1st Rd., Guishan Dist., Taoyuan City, Taiwan (R.O.C.)



Table of Contents

History of this test report.....3

Summary of Test Result.....4

1. General Information5

 1.1. Product Details.....5

 1.2. Accessories.....5

 1.3. Table for Multiple Listing6

 1.4. Table for Carrier Frequencies.....6

 1.5. Antenna Information.....7

 1.6. Table for Test Modes8

 1.7. Table for Testing Locations9

 1.8. Table for Supporting Units.....9

 1.9. Duty Cycle10

 1.10. Test Configurations11

2. Test Result14

 2.1. AC Power Line Conducted Emissions Measurement.....14

 2.2. Field Strength of Fundamental Emissions Measurement.....18

 2.3. 20dB Spectrum Bandwidth Measurement21

 2.4. Radiated Emissions Measurement25

 2.5. Band Edge Emissions Measurement.....34

 2.6. Antenna Requirements.....38

3. List of Measuring Equipments39

4. Measurement Uncertainty.....41

Appendix A. Test Photos

Appendix B. Photographs of EUT



Summary of Test Result

Report Clause	Ref Std. Clause	Test Items	Result (PASS/FAIL)	Remark
2.1	15.207	AC Power Line Conducted Emissions	PASS	-
2.2	15.249(a)	Field Strength of Fundamental Emissions	PASS	-
2.3	15.215(c)	20dB Spectrum Bandwidth	PASS	-
2.4	15.249(a)/(d)	Radiated Emissions	PASS	-
2.5	15.249(d)	Band Edge Emissions	PASS	-
2.6	15.203	Antenna Requirements	PASS	-

Declaration of Conformity:

The test results with all measurement uncertainty excluded are presented in accordance with the regulation limits or requirements declared by manufacturers.

Comments and Explanations:

The declared of product specification for EUT presented in the report are provided by the manufacturer, and the manufacturer takes all the responsibilities for the accuracy of product specification.

Reviewed by: **Sam Chen**

Report Producer: **Cindy Peng**



1. General Information

1.1. Product Details

Items	Description
Power Type	From power adapter
Modulation	908.42 MHz: 2FSK
	908.40 MHz: 2FSK
	916.00 MHz: 2GFSK
Data Rate	908.42 MHz: 9.6kbps
	908.40 MHz: 40kbps
	916.00 MHz: 100kbps
Frequency Range	902~928MHz
Operation Frequency Range	908.42 MHz
	908.40 MHz
	916.00 MHz
Channel Number	3
Channel Bandwidth (99%)	0.11288 MHz
Max. Field Strength	93.88 dBuV/m at 3m (QP)
Carrier Frequencies	Please refer to section 1.3
Antenna	Please refer to section 1.4

Note: The above information was declared by manufacturer.

1.2. Accessories

No.	Equipment Name	Brand Name	Model Name	Rating
1	Adapter 1	LEI	ML42AY120350-A1	INPUT: 105-125V ~ 60Hz, 1.5A OUTPUT: 12V, 3.5A
2	Adapter 2	Delta	ADH-42AW B	INPUT: 105-125V ~ 60Hz, 1.2A OUTPUT: 12V, 3.5A
No.	Other			
3	RJ-45 cable	Non-shielded: 3m		



1.3. Table for Multiple Listing

The equipment names in the following table are all refer to the identical product.

Equipment Name	Model Name	Description
Fios Home Router	G3100	All the equipments are identical, the difference equipment name served as marketing strategy.
Fios Business Router		

1.4. Table for Carrier Frequencies

Frequency Band	Channel No.	Frequency
902~928MHz	1	908.42 MHz
	2	908.40 MHz
	3	916.00 MHz



1.5. Antenna Information

For WLAN and Bluetooth Antenna:

Ant.	Port	Brand	Model Name	Antenna Type	Connector	Gain (dBi)			
						WLAN 2.4GHz	5GHz B1	5GHz B4	BT
1	4	Arcadyan	-	Monopole	N/A	2.2	0.4	-	-
2	2	Arcadyan	12080073700J	PCB	I-PEX	0.3	1.2	-	-
3	3	Arcadyan	12080073800J	PCB	I-PEX	2.49	0.9	-	-
4	1	Arcadyan	12080073900J	PCB	I-PEX	1.7	2.48	-	-
5	3	Arcadyan	12080073400J	PCB	I-PEX	-	-	0.7	-
6	2	Arcadyan	12080073300J	PCB	I-PEX	-	-	1.3	-
7	1	Arcadyan	12080073600J	PCB	I-PEX	-	-	0.4	-
8	4	Arcadyan	12080073500J	PCB	I-PEX	-	-	1.6	-
9	1	Arcadyan	-	PIFA	N/A	-	-	-	-0.85

For Zigbee and Z-wave Antenna:

Ant.	Port	Brand	Model Name	Antenna Type	Connector	Gain (dBi)	
						Zigbee	Z-wave
10	1	Arcadyan	-	PIFA	N/A	4.4	-
11	1	Arcadyan	-	PIFA	N/A	-	0.7

Note: The above information was declared by manufacturer.

<For WLAN 2.4GHz Function>

For IEEE 802.11b mode (1TX/1RX):

Only Port 1 can be used as transmitting/receiving antenna.

For IEEE 802.11g/n/VHT/ax mode (4TX/4RX):

Port 1、Port 2、Port 3 and Port 4 can be used as transmitting/receiving antenna.

Port 1、Port 2、Port 3 and Port 4 could transmit/receive simultaneously.

<For WLAN 5GHz Band 1/Band 4 Function>

For IEEE 802.11a/n/ac mode (4TX/4RX):

Port 1、Port 2、Port 3 and Port 4 can be used as transmitting/receiving antenna.

Port 1、Port 2、Port 3 and Port 4 could transmit/receive simultaneously.

<For Bluetooth Function>

For Bluetooth mode (1TX/1RX)

Only Port 1 can be use as transmit and receive antenna.

<For Zigbee Function>

For Zigbee mode (1TX/1RX)

Only Port 1 can be use as transmit and receive antenna.

<For Z-wave Function>

For Z-wave mode (1TX/1RX)

Only Port 1 can be use as transmit and receive antenna.



1.6. Table for Test Modes

The following table is a list of the test modes shown in this test report.

Test Items	Mode	Channel	Port
AC Power Line Conducted Emissions	CTX	-	1
Field Strength of Fundamental Emissions 20dB Spectrum Bandwidth	CTX	1, 2, 3	1
Radiated Emissions 30MHz ~ 1GHz	CTX	-	1
Radiated Emissions 1GHz~10 th Harmonic	CTX	1, 2, 3	1
Band Edge Emissions	CTX	1, 2, 3	1

The following test modes were performed for all tests:

AC Power Conducted Emissions	
Test Mode	Description
1	WLAN 2.4GHz – EUT + Adapter 1
2	WLAN 2.4GHz – EUT + Adapter 2
Mode 2 has been evaluated to be the worst case among Mode 1~2, thus measurement for Mode 3~7 will follow this same test mode.	
3	WLAN 5GHz – EUT + Adapter 2
4	Bluetooth 4.0 – EUT + Adapter 2
5	Bluetooth 5.0 – EUT + Adapter 2
6	Z-wave – EUT + Adapter 2
7	Zigbee – EUT + Adapter 2
Mode 7 is the worst case, so it was selected to record in this test report.	

Radiated Emissions 30MHz ~ 1GHz	
Test Mode	Description
1	WLAN 2.4GHz – EUT + Adapter 1
2	WLAN 2.4GHz – EUT + Adapter 2
Mode 1 has been evaluated to be the worst case among Mode 1~2, thus measurement for Mode 3~7 will follow this same test mode.	
3	WLAN 5GHz – EUT + Adapter 1
4	Bluetooth 4.0 – EUT + Adapter 1
5	Bluetooth 5.0 – EUT + Adapter 1
6	Z-wave – EUT + Adapter 1
7	Zigbee – EUT + Adapter 1
Mode 4 is the worst case, so it was selected to record in this test report.	



Co-location RF Exposure Evaluation	
Test Mode	Description
1	WLAN 2.4GHz + WLAN 5GHz Band 1 + WLAN 5GHz Band 4 + Bluetooth + Z-wave
2	WLAN 2.4GHz + WLAN 5GHz Band 1 + WLAN 5GHz Band 4 + Zigbee + Z-wave
Refer to Sporton Test Report No.: FA932731 for Co-location RF Exposure Evaluation.	

Note: The EUT can only be used at Y axis position.

1.7. Table for Testing Locations

Testing Location					
<input type="checkbox"/>	HWA YA	ADD	:	No. 52, Huaya 1st Rd., Guishan Dist., Taoyuan City, Taiwan (R.O.C.)	
		TEL	:	886-3-327-3456	FAX : 886-3-327-0973
<input checked="" type="checkbox"/>	JHUBEI	ADD	:	No.8, Lane 724, Bo-ai St., Jhubei City, HsinChu County 302, Taiwan, R.O.C.	
		TEL	:	886-3-656-9065	FAX : 886-3-656-9085

Test Condition	Test Site No.	Test Engineer	Test Environment	Test Date
RF Conducted	TH01-CB	Serway Li	22~24°C / 53~55%	May 02, 2019~Jun. 04, 2019
Radiated (below 1GHz)	03CH04-CB	Stim Sung	22~24°C / 50~60%	Apr. 02, 2019~Jun. 04, 2019
Radiated (above 1GHz)	03CH06-CB			
AC Conduction	CO02-CB	GN Hou	21.2~22.4°C / 62~65%	May 14, 2019

Test site Designation No. TW0006 with FCC.

Test site registered number IC 4086B with Industry Canada.

1.8. Table for Supporting Units

For AC Conduction:

No.	Equipment	Brand Name	Model Name	FCC ID
A	LAN NB	DELL	E6430	N/A
B	Flash disk3.0	Transcend	JetFlash-700	N/A
C	Fixture	Silicon LABs	BRD4001A+SLSDA001A	N/A

For RF Conducted and Radiated:

No.	Equipment	Brand Name	Model Name	FCC ID
A	NB	DELL	E4300	N/A



1.9. Duty Cycle

On Time (ms)	On+Off Time (ms)	Duty Cycle (%)	Duty Factor (dB)	1/T Minimum VBW (kHz)
7.826	31.884	24.55%	6.10	0.13

1.10. Test Configurations

1.10.1. AC Power Line Conduction Emissions Test Configuration

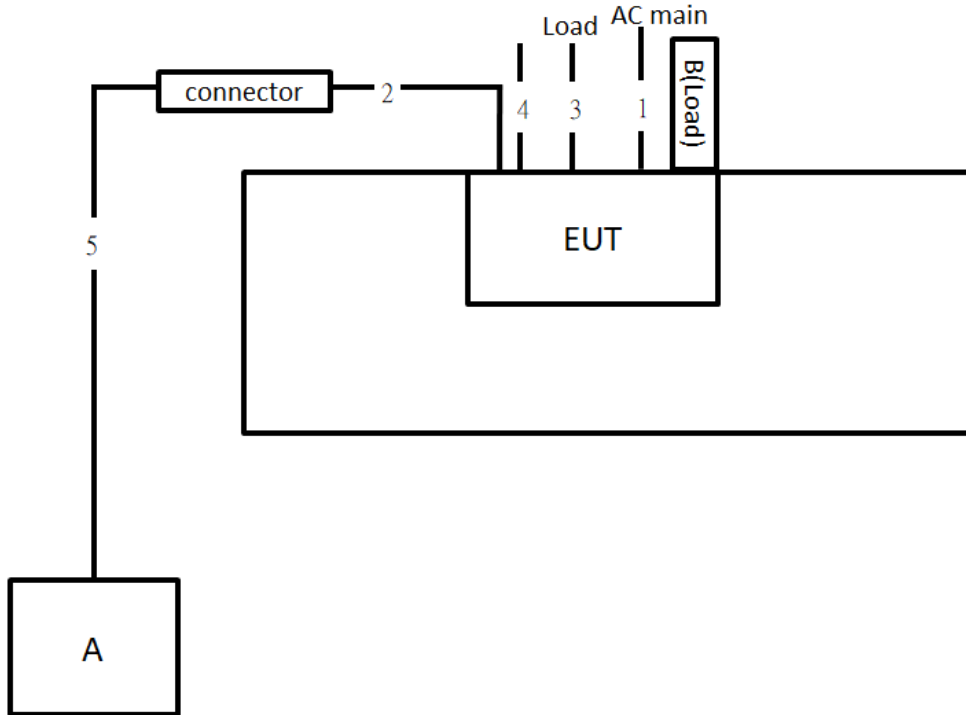

Item	Connection	Shielded	Length
1	Power cable	No	1.5m
2	RJ-45 cable	No	3m
3	RJ-45 cable*4	No	1.5m
4	Coaxial cable	Yes	1.5m
5	RJ-45 cable	No	10m

1.10.2. Radiation Emissions Test Configuration

Test Configuration: 30MHz~1GHz

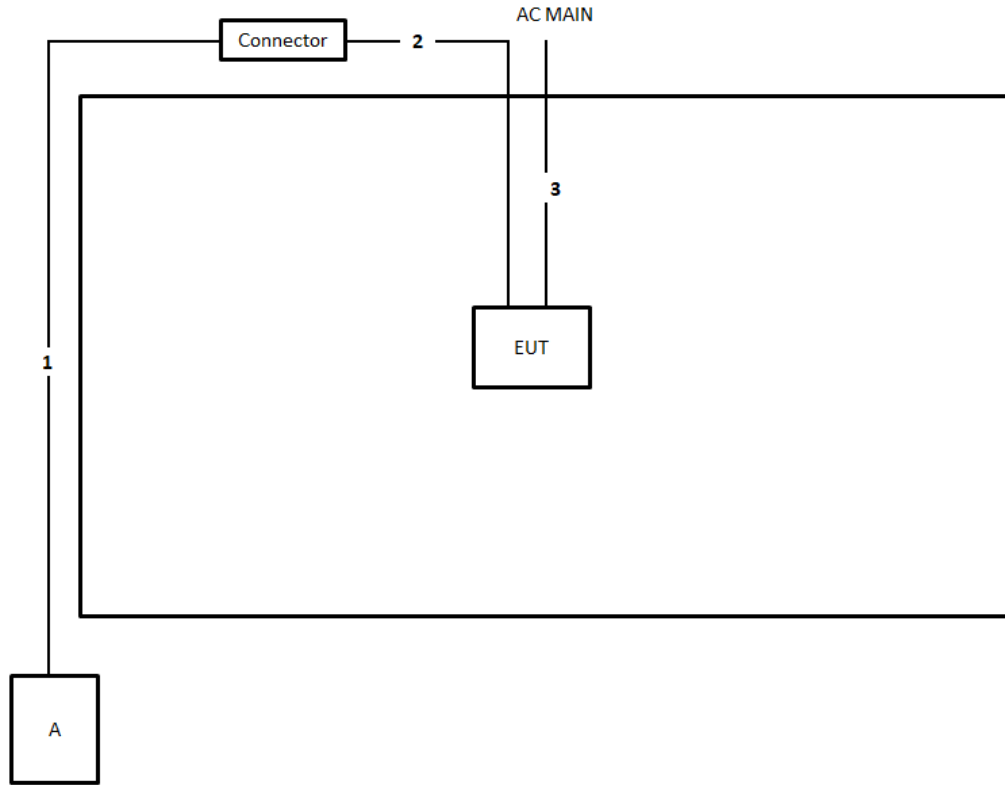

Item	Connection	Shielded	Length
1	RJ-45 cable	No	10m
2	RJ-45 cable	No	3m
3	Power cable	No	1.5m



Test Configuration: Above 1GHz

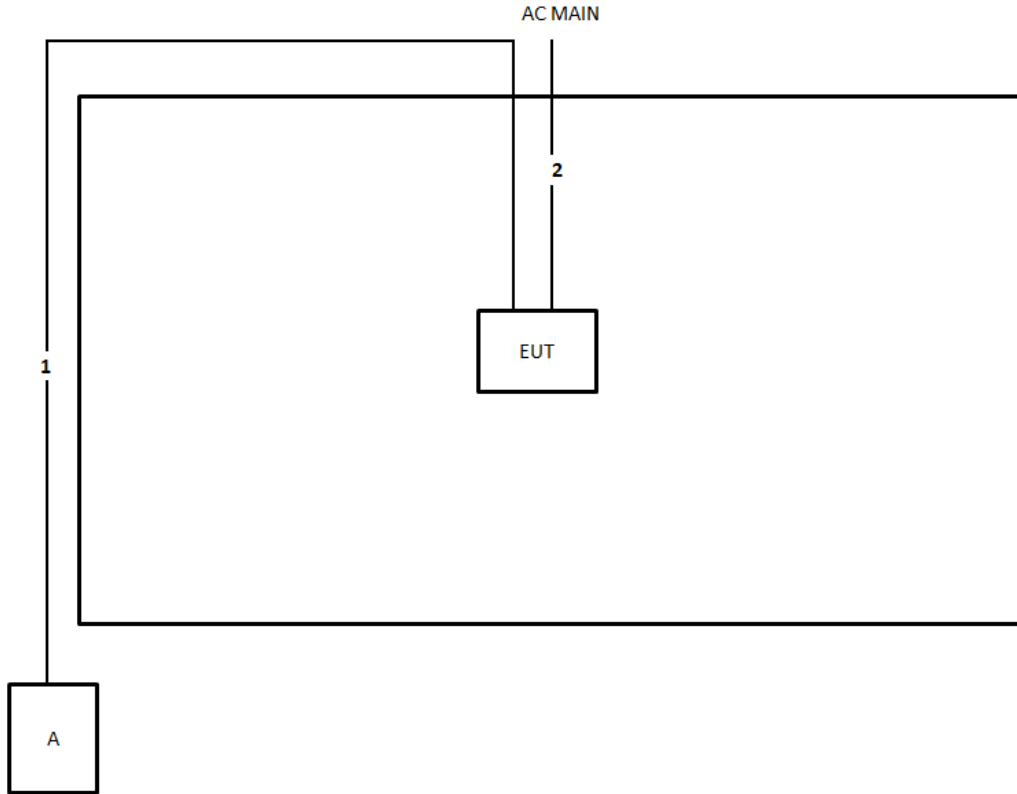

Item	Connection	Shielded	Length
1	RJ-45 cable	No	10m
2	Power cable	No	1.5m



2. Test Result

2.1. AC Power Line Conducted Emissions Measurement

2.1.1. Limit

For this product which is designed to be connected to the AC power line, the radio frequency voltage that is conducted back onto the AC power line on any frequency or frequencies within the band 150 kHz to 30 MHz shall not exceed below limits table.

Frequency (MHz)	QP Limit (dBuV)	AV Limit (dBuV)
0.15~0.5	66~56	56~46
0.5~5	56	46
5~30	60	50

2.1.2. Measuring Instruments and Setting

Refer a test equipment and calibration data table in this test report. The following table is the setting of the receiver.

Receiver Parameters	Setting
Attenuation	10 dB
Start Frequency	0.15 MHz
Stop Frequency	30 MHz
IF Bandwidth	9 kHz

2.1.3. Test Procedures

1. Configure the EUT according to ANSI C63.10. The EUT or host of EUT has to be placed 0.4 meter far from the conducting wall of the shielding room and at least 80 centimeters from any other grounded conducting surface.
2. Connect EUT or host of EUT to the power mains through a line impedance stabilization network (LISN).
3. All the support units are connected to the other LISNs. The LISN should provide 50uH/50ohms coupling impedance.
4. The frequency range from 150 kHz to 30 MHz was searched.
5. Set the test-receiver system to Peak Detect Function and Specified Bandwidth with Maximum Hold Mode.
6. The measurement has to be done between each power line and ground at the power terminal.

2.1.4. Test Setup Layout

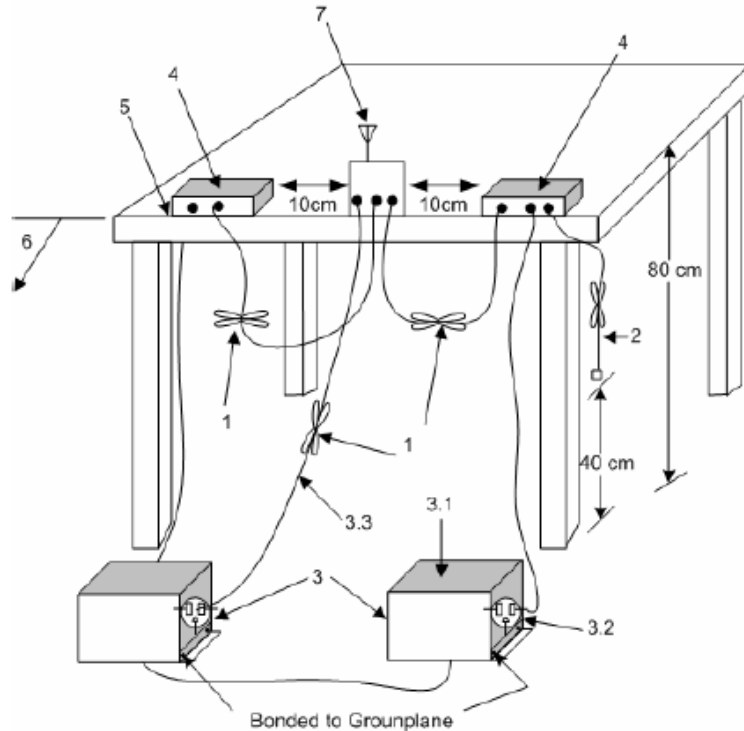

- 1—Interconnecting cables that hang closer than 40 cm to the ground plane shall be folded back and forth in the center forming a bundle 30 cm to 40 cm long.
- 2—The I/O cables that are not connected to an accessory shall be bundled in the center. The end of the cable may be terminated, if required, using the correct terminating impedance. The overall length shall not exceed 1 m.
- 3—EUT connected to one LISN. Unused LISN measuring port connectors shall be terminated in 50 Ω loads. LISN may be placed on top of, or immediately beneath, reference ground plane.
 - 3.1—All other equipment powered from additional LISN(s).
 - 3.2—A multiple-outlet strip may be used for multiple power cords of non-EUT equipment.
 - 3.3—LISN at least 80 cm from nearest part of EUT chassis.
- 4—Non-EUT components of EUT system being tested.
- 5—Rear of EUT, including peripherals, shall all be aligned and flush with edge of tabletop.
- 6—Edge of tabletop shall be 40 cm removed from a vertical conducting plane that is bonded to the ground plane.
- 7—Antenna can be integral or detachable. If detachable, then the antenna shall be attached for this test.

2.1.5. Test Deviation

There is no deviation with the original standard.

2.1.6. EUT Operation during Test

The EUT was placed on the test table and programmed in normal function.



2.1.7. Results of AC Power Line Conducted Emissions Measurement

Configuration	CTX	Phase	Line
Test Mode	Mode 7		

14/05/2019

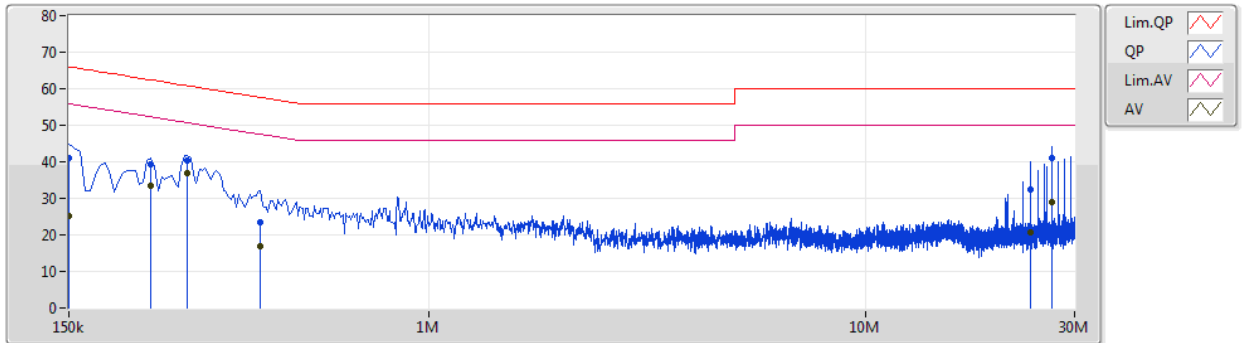

Type	Freq (Hz)	Level (dBuV)	Limit (dBuV)	Margin (dB)	Factor (dB)	Condition	Comment	Raw (dBuV)	AF (dB)	CL (dB)	AT (dB)
QP	150k	41.01	66.00	-24.99	10.17	Line	-	30.84	0.05	0.02	10.10
AV	150k	25.12	56.00	-30.88	10.17	Line	-	14.95	0.05	0.02	10.10
QP	231k	39.44	62.41	-22.97	10.17	Line	-	29.27	0.05	0.02	10.10
AV	231k	33.46	52.41	-18.95	10.17	Line	-	23.29	0.05	0.02	10.10
QP	280.5k	40.21	60.80	-20.59	10.17	Line	-	30.04	0.05	0.02	10.10
AV	280.5k	36.87	50.80	-13.93	10.17	Line	"Worst"	26.70	0.05	0.02	10.10
QP	411k	23.55	57.63	-34.08	10.18	Line	-	13.37	0.06	0.02	10.10
AV	411k	16.90	47.63	-30.73	10.18	Line	-	6.72	0.06	0.02	10.10
QP	23.753M	32.33	60.00	-27.67	10.62	Line	-	21.71	0.32	0.18	10.12
AV	23.753M	20.81	50.00	-29.19	10.62	Line	-	10.19	0.32	0.18	10.12
QP	26.601M	41.07	60.00	-18.93	10.68	Line	-	30.39	0.35	0.21	10.12
AV	26.601M	28.85	50.00	-21.15	10.68	Line	-	18.17	0.35	0.21	10.12



Configuration	CTX	Phase	Neutral
Test Mode	Mode 7		

14/05/2019

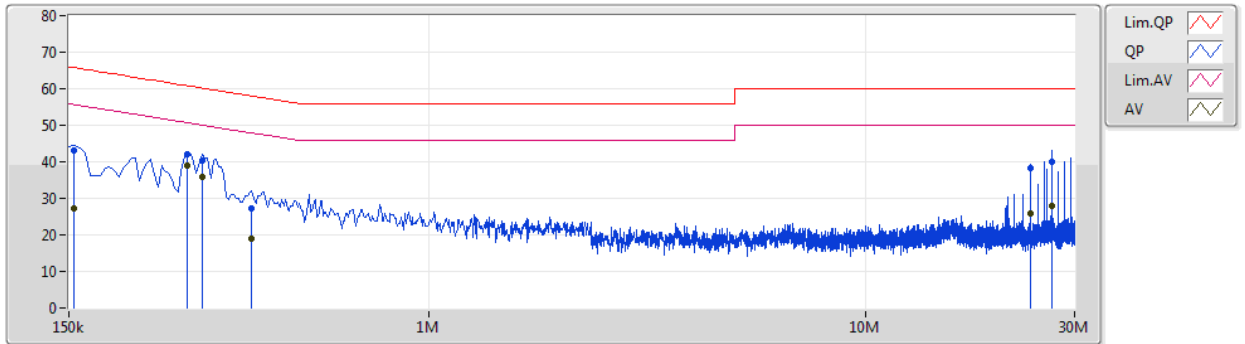

Type	Freq (Hz)	Level (dBuV)	Limit (dBuV)	Margin (dB)	Factor (dB)	Condition	Comment	Raw (dBuV)	AF (dB)	CL (dB)	AT (dB)
QP	154.5k	43.06	65.75	-22.69	10.15	Neutral	-	32.91	0.03	0.02	10.10
AV	154.5k	27.27	55.75	-28.48	10.15	Neutral	-	17.12	0.03	0.02	10.10
QP	280.5k	42.02	60.80	-18.78	10.15	Neutral	-	31.87	0.03	0.02	10.10
AV	280.5k	39.09	50.80	-11.71	10.15	Neutral	"Worst"	28.94	0.03	0.02	10.10
QP	303k	40.18	60.17	-19.99	10.16	Neutral	-	30.02	0.04	0.02	10.10
AV	303k	36.03	50.17	-14.14	10.16	Neutral	-	25.87	0.04	0.02	10.10
QP	393k	27.41	58.01	-30.60	10.16	Neutral	-	17.25	0.04	0.02	10.10
AV	393k	19.03	48.01	-28.98	10.16	Neutral	-	8.87	0.04	0.02	10.10
QP	23.748M	38.17	60.00	-21.83	10.56	Neutral	-	27.61	0.26	0.18	10.12
AV	23.748M	26.03	50.00	-23.97	10.56	Neutral	-	15.47	0.26	0.18	10.12
QP	26.601M	40.04	60.00	-19.96	10.62	Neutral	-	29.42	0.29	0.21	10.12
AV	26.601M	28.09	50.00	-21.91	10.62	Neutral	-	17.47	0.29	0.21	10.12

Note:

Level = Read Level + LISN Factor + Cable Loss



2.2. Field Strength of Fundamental Emissions Measurement

2.2.1. Limit

The field strength of fundamental emissions within these bands specified at a distance of 3 meters (measurement instrumentation employing an average detector) shall comply with the following table.

Frequency Band (MHz)	Fundamental Emissions Limit (dBuV/m) at 3m
902~928MHz	94 (QP)

2.2.2. Measuring Instruments and Setting

Refer a test equipment and calibration data table in this test report. The following table is the setting of the spectrum analyzer.

Power Meter Parameter	Setting
RBW	100 kHz
VBW	300 kHz
Detector	QP
Trace	Max Hold
Sweep Time	Auto

2.2.3. Test Procedures

1. Configure the EUT according to ANSI C63.10. The EUT was placed on the top of the turntable 0.8 meter above ground. The phase center of the receiving antenna mounted on the top of a height-variable antenna tower was placed 3 meters far away from the turntable.
2. Power on the EUT and all the supporting units. The turntable was rotated by 360 degrees to determine the position of the highest radiation.
3. The height of the broadband receiving antenna was varied between one meter and four meters above ground to find the maximum emissions field strength of both horizontal and vertical polarization.
4. For each suspected emissions, the antenna tower was scan (from 1 M to 4 M) and then the turntable was rotated (from 0 degree to 360 degrees) to find the maximum reading.
5. For Fundamental emissions, use 100kHz VBW and 300kHz RBW for QP reading in spectrum analyzer.
6. When the radiated emissions limits are expressed in terms of the average value of the emissions, and pulsed operation is employed, the measurement field strength shall be determined by averaging over one complete pulse train, including blanking intervals, as long as the pulse train does not exceed 0.1 seconds. As an alternative (provided the transmitter operates for longer than 0.1 seconds) or in cases where the pulse train exceeds 0.1 seconds, the measured field strength shall be determined from the average absolute voltage during a 0.1 second interval during which the field strength is at its maximum value.

2.2.4. Test Setup Layout

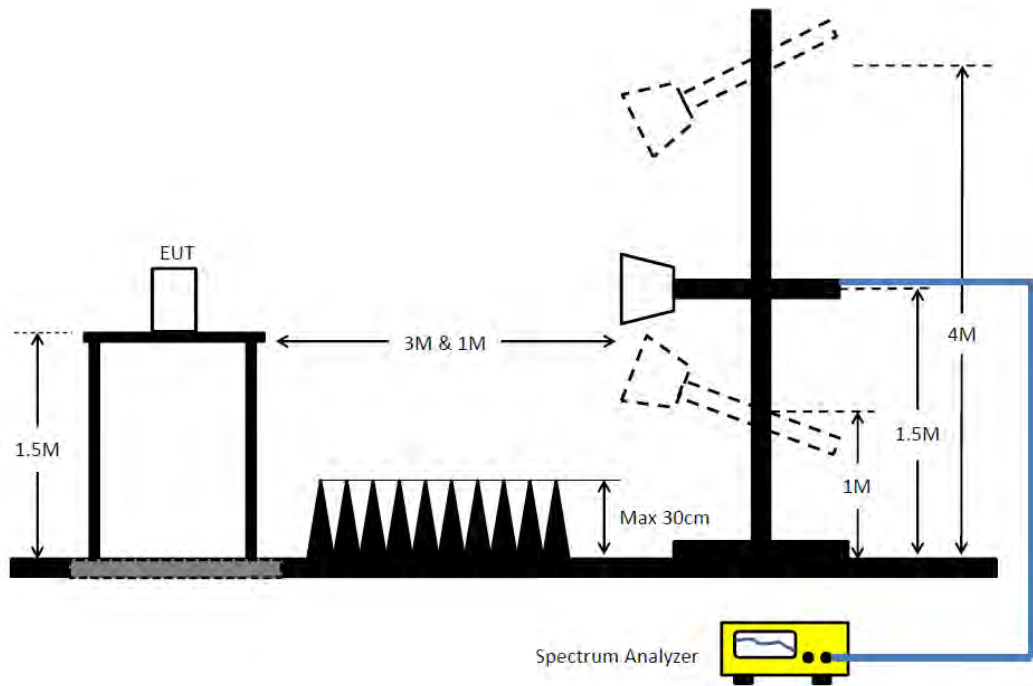

2.2.5. Test Deviation

There is no deviation with the original standard.

2.2.6. EUT Operation during Test

The EUT was programmed to be in continuously transmitting mode.



2.2.7. Test Result of Field Strength of Fundamental Emissions

Configurations	Channel 1, 2, 3
-----------------------	-----------------

Channel 1

	Freq	Level	Limit Line	Over Limit	Read Level	CableAntenna Loss	Preamp Factor	A/Pos	T/Pos	Remark	Pol/Phase
	MHz	dBuV/m	dBuV/m	dB	dBuV	dB	dB/m	dB	cm	deg	
1	875.00	31.57	46.00	-14.43	34.00	3.09	26.19	31.71	128	255 QP	VERTICAL
2	896.00	38.17	46.00	-7.83	40.00	3.09	26.71	31.63	102	36 QP	VERTICAL
3	901.40	36.31	46.00	-9.69	38.00	3.09	26.81	31.59	106	278 QP	VERTICAL
4	908.40	93.88	93.98	-0.10	95.59	3.13	26.67	31.51	128	255 QP	VERTICAL
5	930.20	31.45	46.00	-14.55	32.99	3.22	26.60	31.36	100	358 QP	VERTICAL

Channel 2

	Freq	Level	Limit Line	Over Limit	Read Level	CableAntenna Loss	Preamp Factor	A/Pos	T/Pos	Remark	Pol/Phase
	MHz	dBuV/m	dBuV/m	dB	dBuV	dB	dB/m	dB	cm	deg	
1	874.90	31.53	46.00	-14.47	34.00	3.09	26.19	31.75	114	187 QP	VERTICAL
2	896.00	35.17	46.00	-10.83	37.00	3.09	26.71	31.63	102	102 QP	VERTICAL
3	901.10	36.31	46.00	-9.69	38.00	3.09	26.81	31.59	109	311 QP	VERTICAL
4	908.40	93.88	93.98	-0.10	95.59	3.13	26.67	31.51	125	253 QP	VERTICAL
5	932.90	31.49	46.00	-14.51	32.99	3.24	26.62	31.36	105	101 QP	VERTICAL

Channel 3

	Freq	Level	Limit Line	Over Limit	Read Level	CableAntenna Loss	Preamp Factor	A/Pos	T/Pos	Remark	Pol/Phase
	MHz	dBuV/m	dBuV/m	dB	dBuV	dB	dB/m	dB	cm	deg	
1	875.00	35.57	46.00	-10.43	38.00	3.09	26.19	31.71	100	104 QP	HORIZONTAL
2	916.00	93.82	93.98	-0.16	95.60	3.16	26.57	31.51	100	154 QP	HORIZONTAL
3	931.70	34.49	46.00	-11.51	35.99	3.24	26.62	31.36	100	119 QP	HORIZONTAL

Note:

Emission level (dBuV/m) = 20 log Emission level (uV/m)

Corrected Reading: Antenna Factor + Cable Loss + Read Level - Preamp Factor = Level

2.3. 20dB Spectrum Bandwidth Measurement

2.3.1. Limit

Intentional radiators must be designed to ensure that the 20 dB bandwidth of the emissions in the specific band (902~928MHz).

2.3.2. Measuring Instruments and Setting

Refer a test equipment and calibration data table in this test report. The following table is the setting of the spectrum analyzer.

Spectrum Parameters	Setting
Attenuation	Auto
Span Frequency	> 20dB Bandwidth
RBW	10 kHz
VBW	10 kHz
Detector	Peak
Trace	Max Hold
Sweep Time	Auto

2.3.3. Test Procedures

1. The transmitter output (antenna port) was connected to the spectrum analyzer in peak hold mode.
2. The resolution bandwidth of 10 kHz and the video bandwidth of 10 kHz were used.
3. Measured the spectrum width with power higher than 20dB below carrier.

2.3.4. Test Setup Layout

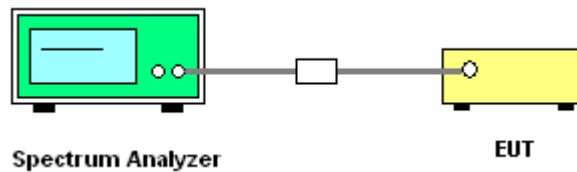

2.3.5. Test Deviation

There is no deviation with the original standard.

2.3.6. EUT Operation during Test

The EUT was programmed to be in continuously transmitting mode.



2.3.7. Test Result of 20dB Spectrum Bandwidth

Configurations	Channel 1, 2, 3
-----------------------	-----------------

Frequency	20dB BW (MHz)	99% OBW (MHz)	Frequency range (MHz) $f_L > 902\text{MHz}$	Frequency range (MHz) $f_H < 928\text{MHz}$	Test Result
908.42 MHz	0.0839	0.07525	908.3968	908.4808	PASS
908.40 MHz	0.0953	0.08973	908.3508	908.4463	PASS
916.00 MHz	0.1187	0.11288	915.9392	916.0579	PASS



20 dB/99% Bandwidth Bandwidth Plot on 908.42 MHz

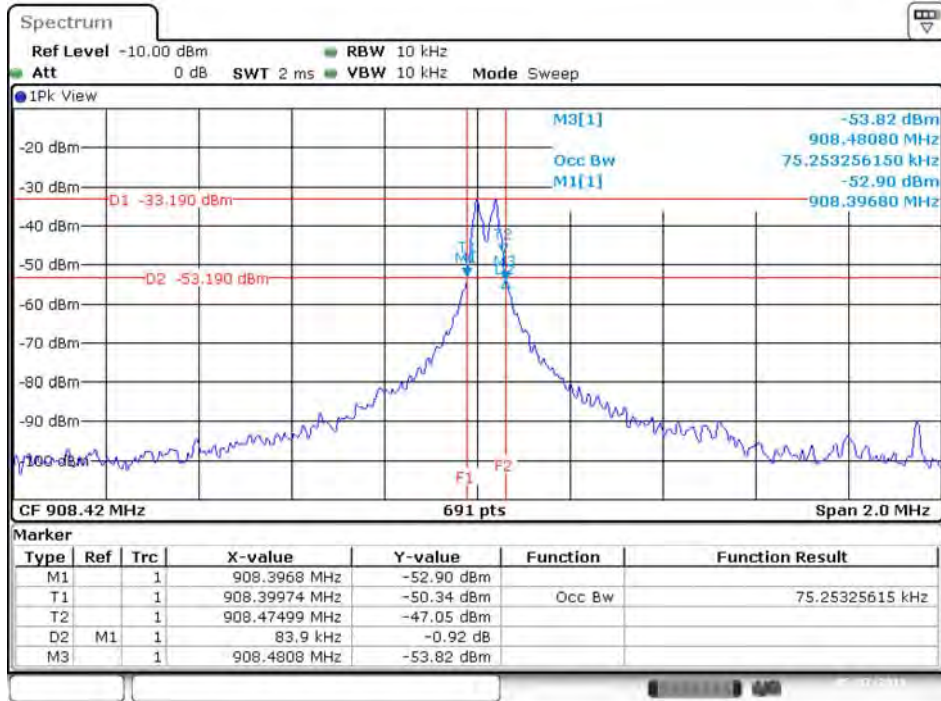

Date: 7.MAY.2019 01:52:49

20 dB/99% Bandwidth Plot on 908.40 MHz

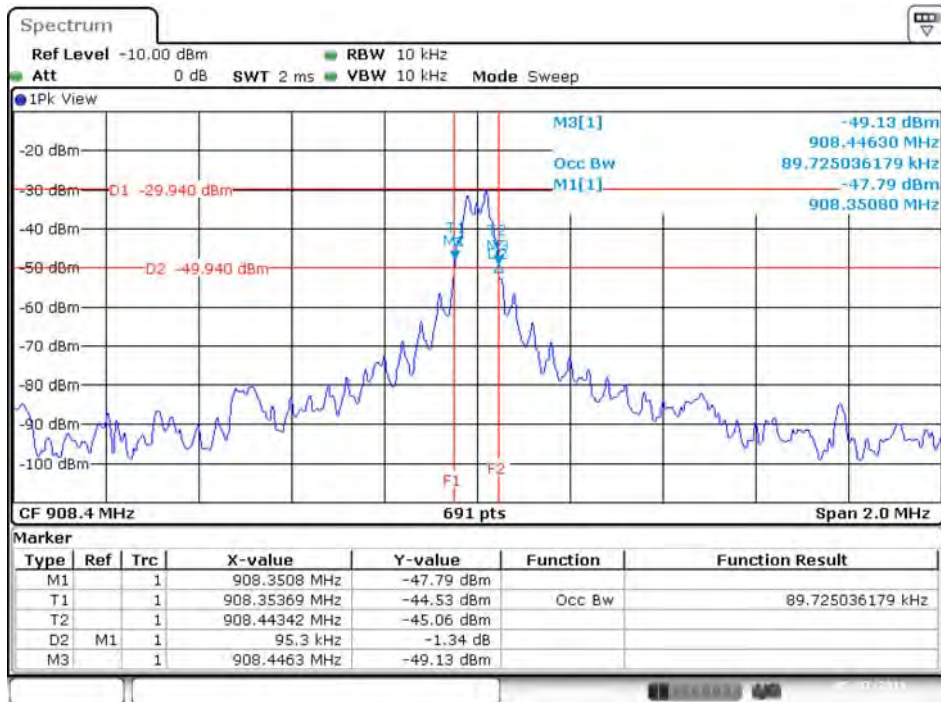

Date: 7.MAY.2019 02:05:23



20 dB/99% Bandwidth Plot on 916.00 MHz

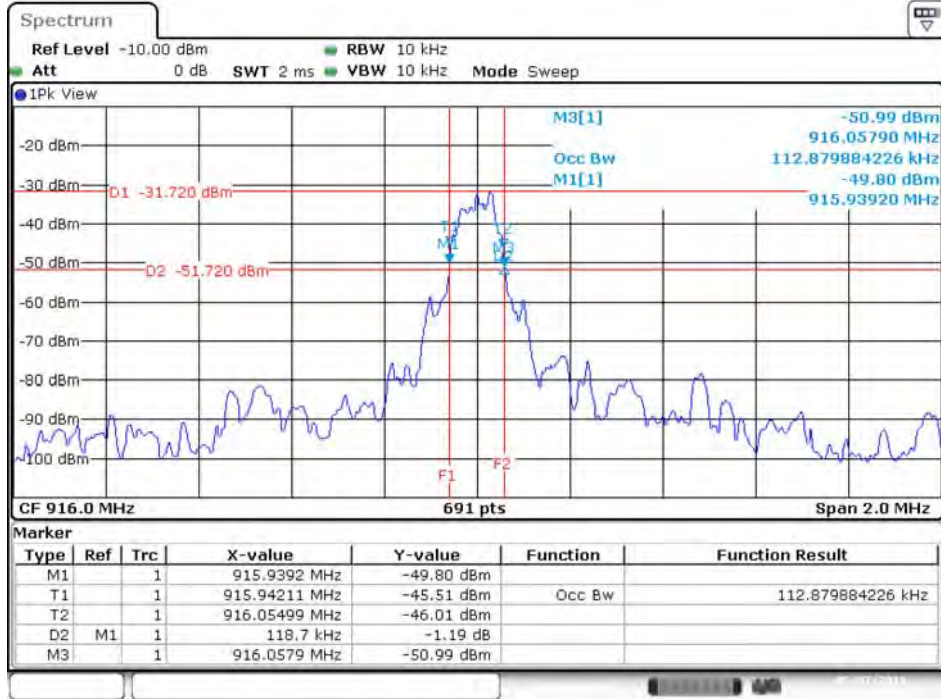

Date: 7.MAY.2019 02:13:46



2.4. Radiated Emissions Measurement

2.4.1. Limit

Harmonic emissions limits comply with below 54 dBuV/m at 3m. Other emissions radiated outside of the specified frequency bands, except for harmonics, shall be attenuated by at least 50 dB below the level of the fundamental or comply with the radiated emissions limits specified in section 15.209(a) limit in the table below has to be followed.

Table with 3 columns: Frequencies (MHz), Field Strength (micorvolts/meter), Measurement Distance (meters). Rows include frequency ranges like 0.009~0.490, 0.490~1.705, 1.705~30.0, 30~88, 88~216, 216~960, and Above 960.

2.4.2. Measuring Instruments and Setting

Refer a test equipment and calibration data table in this test report. The following table is the setting of the spectrum analyzer and receiver.

Table with 2 columns: Spectrum Parameter, Setting. Rows include Attenuation (Auto), Start Frequency (1000 MHz), Stop Frequency (10th carrier harmonic), and RBW / VBW settings for restricted and non-restricted bands.

Table with 2 columns: Receiver Parameter, Setting. Rows include Attenuation (Auto) and three Start ~ Stop Frequency ranges with corresponding RBW settings for QP.



2.4.3. Test Procedures

1. Configure the EUT according to ANSI C63.10. The EUT was placed on the top of the turntable 1.5 meter above ground. The phase center of the receiving antenna mounted on the top of a height-variable antenna tower was placed 3 meters far away from the turntable.
2. Power on the EUT and all the supporting units. The turntable was rotated by 360 degrees to determine the position of the highest radiation.
3. The height of the broadband receiving antenna was varied between one meter and four meters above ground to find the maximum emissions field strength of both horizontal and vertical polarization.
4. For each suspected emissions, the antenna tower was scan (from 1 M to 4 M) and then the turntable was rotated (from 0 degree to 360 degrees) to find the maximum reading.
5. Set the test-receiver system to Peak or CISPR quasi-peak Detect Function with specified bandwidth under Maximum Hold Mode.
6. For emissions above 1GHz, use 1MHz VBW and 3MHz RBW for peak reading. Then 1MHz RBW and 1/T VBW for average reading in spectrum analyzer.
7. When the radiated emissions limits are expressed in terms of the average value of the emissions, and pulsed operation is employed, the measurement field strength shall be determined by averaging over one complete pulse train, including blanking intervals, as long as the pulse train does not exceed 0.1 seconds. As an alternative (provided the transmitter operates for longer than 0.1 seconds) or in cases where the pulse train exceeds 0.1 seconds, the measured field strength shall be determined from the average absolute voltage during a 0.1 second interval during which the field strength is at its maximum value.
8. If the emissions level of the EUT in peak mode was 3 dB lower than the average limit specified, then testing will be stopped and peak values of EUT will be reported, otherwise, the emissions which do not have 3 dB margin will be repeated one by one using the quasi-peak method for below 1GHz.
9. For testing above 1GHz, the emissions level of the EUT in peak mode was lower than average limit (that means the emissions level in peak mode also complies with the limit in average mode), then testing will be stopped and peak values of EUT will be reported, otherwise, the emissions will be measured in average mode again and reported.
10. In case the emission is lower than 30MHz, loop antenna has to be used for measurement and the recorded data should be QP measured by receiver. High – Low scan is not required in this case.

2.4.4. Test Setup Layout

For Radiated Emissions: 9kHz ~30MHz

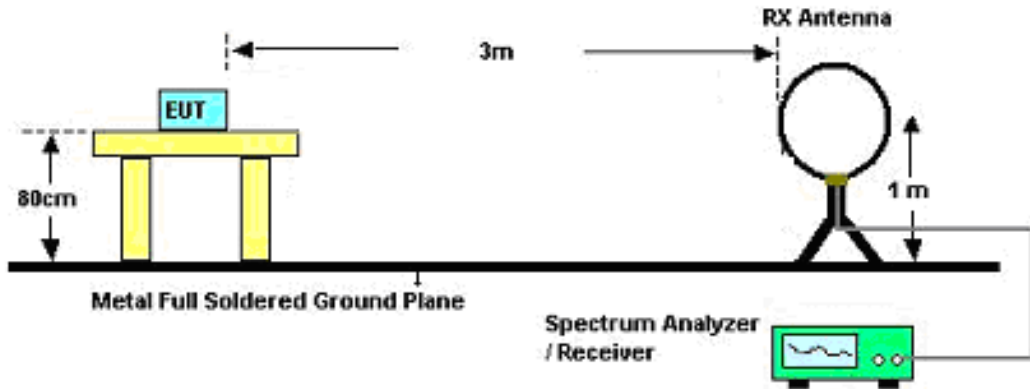

For Radiated Emissions: 30MHz~1GHz

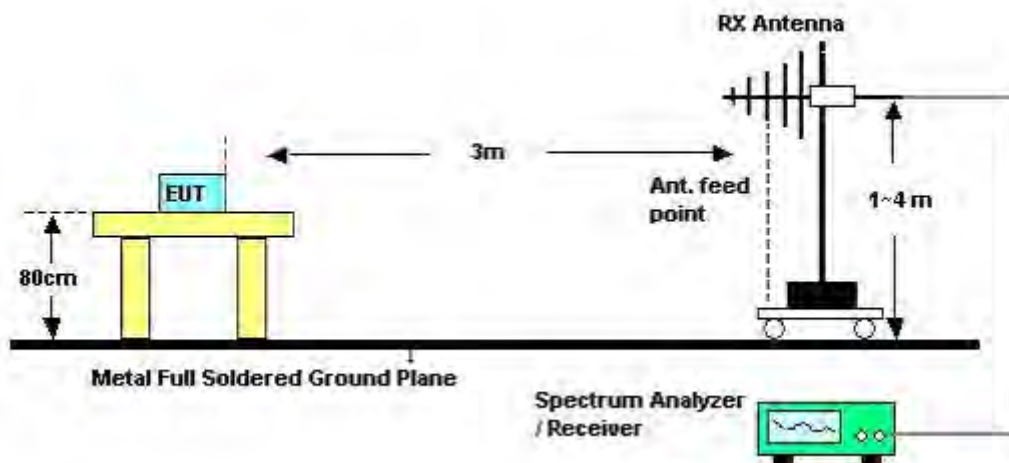



2.4.8. Results of Radiated Emissions (30MHz~1GHz)

Configuration	CTX	Test Mode	Mode 4
---------------	-----	-----------	--------

Horizontal

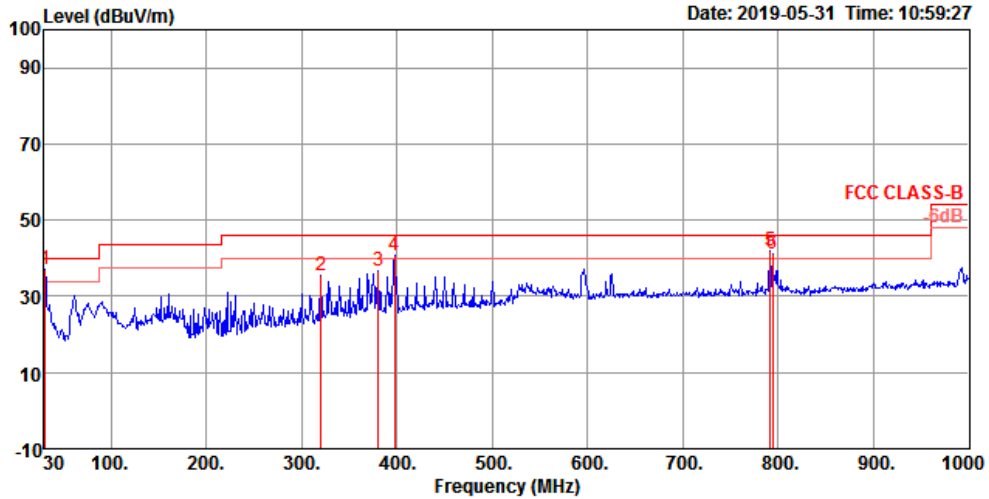

	Freq	Level	Limit	Over	Read	CableAntenna	Preamp	A/Pos	T/Pos	Remark	Pol/Phase	
	MHz	dBuV/m	dBuV/m	dB	dBuV	dB	dB/m	dB	cm	deg		
1	30.97	36.89	40.00	-3.11	45.06	0.51	23.51	32.19	125	140	Peak	HORIZONTAL
2	320.03	35.39	46.00	-10.61	45.96	1.92	19.48	31.97	100	117	Peak	HORIZONTAL
3	380.17	36.82	46.00	-9.18	45.85	2.11	20.85	31.99	100	300	Peak	HORIZONTAL
4	397.63	40.63	46.00	-5.37	49.03	2.14	21.55	32.09	100	309	Peak	HORIZONTAL
5	791.45	41.85	46.00	-4.15	44.52	3.05	26.00	31.72	150	153	Peak	HORIZONTAL
6	794.36	40.96	46.00	-5.04	43.51	3.06	26.09	31.70	150	153	Peak	HORIZONTAL



Vertical

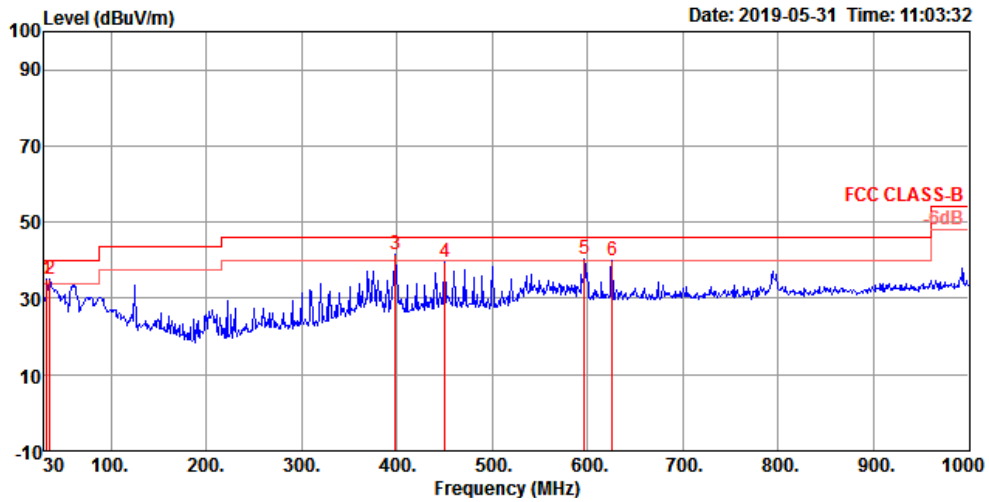

	Freq	Level	Limit	Over	Read	Cable	Antenna	Preamp	A/Pos	T/Pos	Remark	Pol/Phase
	MHz	dBuV/m	dBuV/m	dB	dBuV	dB	dB/m	dB	cm	deg		
1	32.91	35.00	40.00	-5.00	44.26	0.54	22.40	32.20	100	135	Peak	VERTICAL
2	35.82	34.88	40.00	-5.12	45.83	0.58	20.68	32.21	200	196	Peak	VERTICAL
3	398.60	41.43	46.00	-4.57	49.76	2.15	21.61	32.09	100	220	Peak	VERTICAL
4	450.01	39.38	46.00	-6.62	46.10	2.32	22.80	31.84	125	250	Peak	VERTICAL
5	596.48	40.25	46.00	-5.75	44.99	2.59	24.67	32.00	150	226	Peak	VERTICAL
6	625.58	39.96	46.00	-6.04	44.15	2.66	25.21	32.06	100	255	Peak	VERTICAL

Note:

The amplitude of spurious emissions which are attenuated by more than 20dB below the permissible value has no need to be reported.

Emission level (dBuV/m) = 20 log Emission level (uV/m).

Corrected Reading: Antenna Factor + Cable Loss + Read Level - Preamp Factor = Level.



2.4.9. Results for Radiated Emissions (1GHz~10th Harmonic)

Configurations	Channel 1
-----------------------	-----------

Horizontal

	Freq	Level	Limit Line	Over Limit	Read Level	CableAntenna Loss	Preamp Factor	A/Pos	T/Pos	Remark	Pol/Phase	
	MHz	dBuV/m	dBuV/m	dB	dBuV	dB	dB/m	dB	cm	deg		
1	2725.17	49.93	74.00	-24.07	49.45	6.00	28.65	34.17	178	158	Peak	HORIZONTAL
2	2725.34	37.48	54.00	-16.52	37.00	6.00	28.65	34.17	178	158	Average	HORIZONTAL

Vertical

	Freq	Level	Limit Line	Over Limit	Read Level	CableAntenna Loss	Preamp Factor	A/Pos	T/Pos	Remark	Pol/Phase	
	MHz	dBuV/m	dBuV/m	dB	dBuV	dB	dB/m	dB	cm	deg		
1	2725.30	44.17	54.00	-9.83	43.69	6.00	28.65	34.17	150	270	Average	VERTICAL
2	2725.35	58.58	74.00	-15.42	58.10	6.00	28.65	34.17	150	270	Peak	VERTICAL

Note:

The amplitude of spurious emissions which are attenuated by more than 20dB below the permissible value has no need to be reported.

Emission level (dBuV/m) = 20 log Emission level (uV/m).

Corrected Reading: Antenna Factor + Cable Loss + Read Level - Preamp Factor = Level.



Configurations	Channel 2
-----------------------	-----------

Horizontal

	Freq	Level	Limit Line	Over Limit	Read Level	CableAntenna Loss	Preamp Factor	A/Pos	T/Pos	Remark	Pol/Phase	
	MHz	dBuV/m	dBuV/m	dB	dBuV	dB	dB/m	dB	cm	deg		
1	2725.27	35.14	54.00	-18.86	34.66	6.00	28.65	34.17	178	159	Average	HORIZONTAL
2	2725.29	50.26	74.00	-23.74	49.78	6.00	28.65	34.17	178	159	Peak	HORIZONTAL

Vertical

	Freq	Level	Limit Line	Over Limit	Read Level	CableAntenna Loss	Preamp Factor	A/Pos	T/Pos	Remark	Pol/Phase	
	MHz	dBuV/m	dBuV/m	dB	dBuV	dB	dB/m	dB	cm	deg		
1	2725.04	59.72	74.00	-14.28	59.24	6.00	28.65	34.17	200	269	Peak	VERTICAL
2	2725.23	38.15	54.00	-15.85	37.67	6.00	28.65	34.17	200	269	Average	VERTICAL

Note:

The amplitude of spurious emissions which are attenuated by more than 20dB below the permissible value has no need to be reported.

Emission level (dBuV/m) = 20 log Emission level (uV/m).

Corrected Reading: Antenna Factor + Cable Loss + Read Level - Preamp Factor = Level.



Configurations	Channel 3
-----------------------	-----------

Horizontal

	Freq	Level	Limit Line	Over Limit	Read Level	CableAntenna Loss	Preamp Factor	Preamp Factor	A/Pos	T/Pos	Remark	Pol/Phase
	MHz	dBuV/m	dBuV/m	dB	dBuV	dB	dB/m	dB	cm	deg		
1	1832.05	49.57	74.00	-24.43	53.96	4.50	25.84	34.73	179	160	Peak	HORIZONTAL
2	1832.07	29.68	54.00	-24.32	34.07	4.50	25.84	34.73	179	160	Average	HORIZONTAL

Vertical

	Freq	Level	Limit Line	Over Limit	Read Level	CableAntenna Loss	Preamp Factor	Preamp Factor	A/Pos	T/Pos	Remark	Pol/Phase
	MHz	dBuV/m	dBuV/m	dB	dBuV	dB	dB/m	dB	cm	deg		
1	1831.97	56.70	74.00	-17.30	61.09	4.50	25.84	34.73	202	267	Peak	VERTICAL
2	1832.03	30.79	54.00	-23.21	35.18	4.50	25.84	34.73	202	267	Average	VERTICAL

Note:

The amplitude of spurious emissions which are attenuated by more than 20dB below the permissible value has no need to be reported.

Emission level (dBuV/m) = 20 log Emission level (uV/m).

Corrected Reading: Antenna Factor + Cable Loss + Read Level - Preamp Factor = Level.



2.5. Band Edge Emissions Measurement

2.5.1. Limit

Band edge emissions radiated outside of the specified frequency bands shall be attenuated by at least 50 dB below the level of the fundamental or comply with the radiated emissions limits specified in section 15.209(a) limit in the table below has to be followed.

Frequencies (MHz)	Field Strength (microvolts/meter)	Measurement Distance (meters)
0.009~0.490	2400/F(kHz)	300
0.490~1.705	24000/F(kHz)	30
1.705~30.0	30	30
30~88	100	3
88~216	150	3
216~960	200	3
Above 960	500	3

2.5.2. Measuring Instruments and Setting

Refer a test equipment and calibration data table in this test report. The following table is the setting of the spectrum analyzer.

Spectrum Parameter	Setting
Attenuation	Auto
Span Frequency	100 MHz
RBW / VBW (Emission in restricted band)	RBW 120kHz for QP
RBW / VBW (Emission in non-restricted band)	100kHz/300kHz for Peak

2.5.3. Test Procedures

The test procedure is the same as section 2.2.3.

2.5.4. Test Setup Layout

This test setup layout is the same as that shown in section 2.2.4.

2.5.5. Test Deviation

There is no deviation with the original standard.

2.5.6. EUT Operation during Test

The EUT was programmed to be in continuously transmitting mode.



2.5.7. Test Result of Band Edge and Fundamental Emissions

Configurations	Channel 1, 2, 3
-----------------------	-----------------

Channel 1

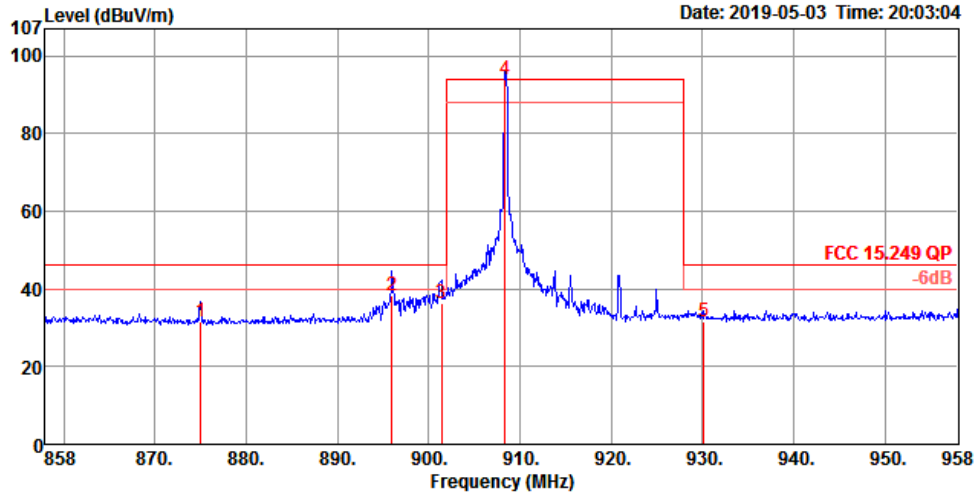

	Freq	Level	Limit	Over	Read	CableAntenna	Preamp	A/Pos	T/Pos	Remark	Pol/Phase
	MHz	dBuV/m	dBuV/m	dB	dBuV	dB	dB/m	dB	cm	deg	
1	875.00	31.57	46.00	-14.43	34.00	3.09	26.19	31.71	128	255 QP	VERTICAL
2	896.00	38.17	46.00	-7.83	40.00	3.09	26.71	31.63	102	36 QP	VERTICAL
3	901.40	36.31	46.00	-9.69	38.00	3.09	26.81	31.59	106	278 QP	VERTICAL
4	908.40	93.88	46.00	-14.55	95.59	3.13	26.67	31.51	128	255 QP	VERTICAL
5	930.20	31.45	46.00	-14.55	32.99	3.22	26.60	31.36	100	358 QP	VERTICAL

Item 4 is the fundamental frequency at 908.42 MHz.



Channel 2

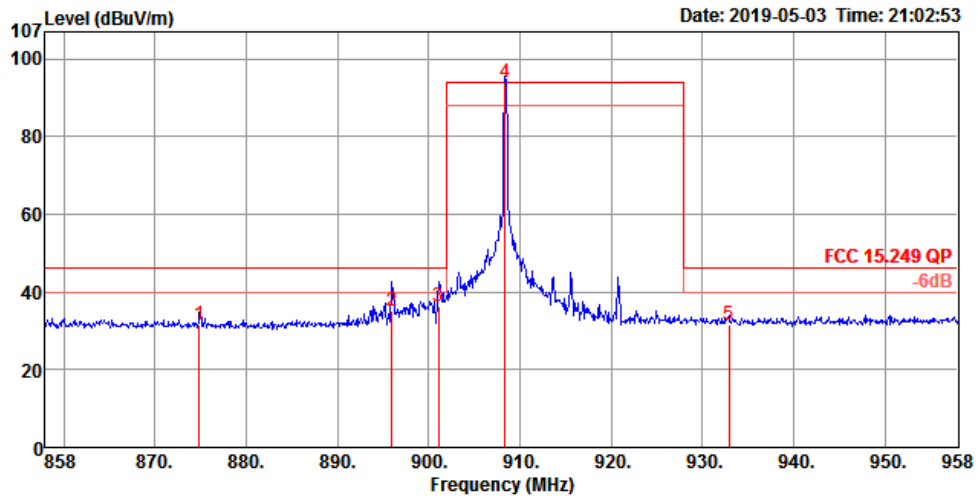

	Freq	Level	Limit Line	Over Limit	Read Level	CableAntenna Loss	Preamp Factor	A/Pos	T/Pos	Remark	Pol/Phase
	MHz	dBuV/m	dBuV/m	dB	dBuV	dB	dB/m	dB	cm	deg	
1	874.90	31.53	46.00	-14.47	34.00	3.09	26.19	31.75	114	187 QP	VERTICAL
2	896.00	35.17	46.00	-10.83	37.00	3.09	26.71	31.63	102	102 QP	VERTICAL
3	901.10	36.31	46.00	-9.69	38.00	3.09	26.81	31.59	109	311 QP	VERTICAL
4	908.40	93.88			95.59	3.13	26.67	31.51	125	253 QP	VERTICAL
5	932.90	31.49	46.00	-14.51	32.99	3.24	26.62	31.36	105	101 QP	VERTICAL

Item 4 is the fundamental frequency at 908.40 MHz.



Channel 3

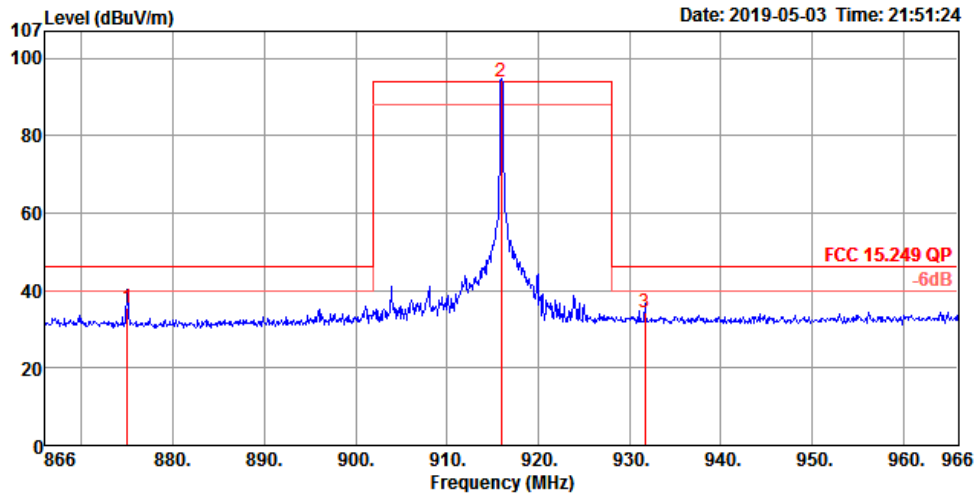

	Freq	Level	Limit	Over	Read	CableAntenna	Preamp	A/Pos	T/Pos	Remark	Pol/Phase
	MHz	dBuV/m	dBuV/m	dB	dBuV	dB	dB/m	dB	cm	deg	
1	875.00	35.57	46.00	-10.43	38.00	3.09	26.19	31.71	100	104 QP	HORIZONTAL
2	916.00	93.82			95.60	3.16	26.57	31.51	100	154 QP	HORIZONTAL
3	931.70	34.49	46.00	-11.51	35.99	3.24	26.62	31.36	100	119 QP	HORIZONTAL

Item 2 is the fundamental frequency at 916.00 MHz.

Note:

Emission level (dBuV/m) = 20 log Emission level (uV/m).

Corrected Reading: Antenna Factor + Cable Loss + Read Level - Preamp Factor = Level.



2.6. Antenna Requirements

2.6.1. Limit

Except for special regulations, the Low-power Radio-frequency Devices must not be equipped with any jacket for installing an antenna with extension cable. An intentional radiator shall be designed to ensure that no antenna other than that furnished by the responsible party shall be used with the device. The use of a permanently attached antenna or of an antenna that uses a unique coupling to the intentional radiator shall be considered sufficient to comply with the provisions of this Section. The manufacturer may design the unit so that the user can replace a broken antenna, but the use of a standard antenna jack or electrical connector is prohibited.

2.6.2. Antenna Connector Construction

The antenna connector complied with the requirements.



3. List of Measuring Equipments

Instrument	Manufacturer	Model No.	Serial No.	Characteristics	Calibration Date	Calibration Due Date	Remark
LISN	Schwarzbeck	NSLK 8127	8127650	9kHz ~ 30MHz	Nov. 21, 2018	Nov. 20, 2019	Conduction (CO02-CB)
LISN	Schwarzbeck	NSLK 8127	8127478	9kHz ~ 30MHz	Nov. 05, 2018	Nov. 04, 2019	Conduction (CO02-CB)
EMI Receiver	Agilent	N9038A	MY52260140	9kHz ~ 8.4GHz	Jan. 16, 2019	Jan. 15, 2020	Conduction (CO02-CB)
COND Cable	Woken	Cable	2	0.15MHz ~ 30MHz	Nov. 06, 2018	Nov. 05, 2019	Conduction (CO02-CB)
Software	Audix	E3	6.120210n	-	N.C.R.	N.C.R.	Conduction (CO02-CB)
Loop Antenna	Teseq	HLA 6120	24155	9kHz - 30 MHz	Mar. 29, 2019	Mar. 28, 2020	Radiation (03CH04-CB)
BILOG ANTENNA with 6 dB attenuator	Schaffner & Woken	CBL6112B & N-6-06	22021&AT-N0607	30MHz ~ 1GHz	Oct. 12, 2018	Oct. 11, 2019	Radiation (03CH04-CB)
Pre-Amplifier	Agilent	310N	187291	0.1MHz ~ 1GHz	Mar. 19, 2019	Mar. 18, 2020	Radiation (03CH04-CB)
Spectrum Analyzer	R&S	FSP40	100142	9kHz~40GHz	Dec. 26, 2018	Dec. 25, 2019	Radiation (03CH04-CB)
EMI Test Receiver	R&S	ESCS	100359	9kHz ~ 2.75GHz	Jul. 03, 2018	Jul. 02, 2019	Radiation (03CH04-CB)
RF Cable-low	Woken	RG402	Low Cable-03+22	30MHz ~ 1GHz	Oct. 08, 2018	Oct. 07, 2019	Radiation (03CH04-CB)
Horn Antenna	SCHWARZBECK	BBHA9120D	9120D-1292	1GHz~18GHz	Jul. 20, 2018	Jul. 19, 2019	Radiation (03CH06-CB)
Pre-Amplifier	Agilent	83017A	MY53270064	0.5GHz ~ 26.5GHz	May 09, 2018	May 08, 2019	Radiation (03CH06-CB)
Pre-Amplifier	Agilent	83017A	MY53270064	0.5GHz ~ 26.5GHz	May 08, 2019	May 07, 2020	Radiation (03CH06-CB)
Spectrum analyzer	R&S	FSP40	100080	9kHz~40GHz	Oct. 03, 2018	Oct. 02, 2019	Radiation (03CH06-CB)
RF Cable-high	HUBER+SUHNER	RG402	High Cable-05	1GHz~18GHz	Oct. 08, 2018	Oct. 07, 2019	Radiation (03CH06-CB)
RF Cable-high	HUBER+SUHNER	RG402	High Cable-05+24	1GHz~18GHz	Oct. 08, 2018	Oct. 07, 2019	Radiation (03CH06-CB)
Spectrum analyzer	R&S	FSV40	100979	9kHz~40GHz	Feb. 25, 2019	Feb. 24, 2020	Conducted (TH01-CB)
RF Cable-high	Woken	RG402	High Cable-06	1 GHz ~ 26.5 GHz	Oct. 08, 2018	Oct. 07, 2019	Conducted (TH01-CB)
RF Cable-high	Woken	RG402	High Cable-07	1 GHz ~26.5 GHz	Oct. 08, 2018	Oct. 07, 2019	Conducted (TH01-CB)
RF Cable-high	Woken	RG402	High Cable-08	1 GHz ~26.5 GHz	Oct. 08, 2018	Oct. 07, 2019	Conducted (TH01-CB)



Instrument	Manufacturer	Model No.	Serial No.	Characteristics	Calibration Date	Calibration Due Date	Remark
RF Cable-high	Woken	RG402	High Cable-09	1 GHz –26.5 GHz	Oct. 08, 2018	Oct. 07, 2019	Conducted (TH01-CB)
RF Cable-high	Woken	RG402	High Cable-10	1 GHz –26.5 GHz	Oct. 08, 2018	Oct. 07, 2019	Conducted (TH01-CB)
RF Cable-high	Woken	RG402	High Cable-28	1 GHz –26.5 GHz	Nov. 19, 2018	Nov. 18, 2019	Conducted (TH01-CB)
Power Sensor	Agilent	E9327A	US40442088	50MHz~18GHz	Jan. 15, 2019	Jan. 14, 2020	Conducted (TH01-CB)
Power Meter	Agilent	E4416A	GB41291199	50MHz~18GHz	Jan. 15, 2019	Jan. 14, 2020	Conducted (TH01-CB)

Note: Calibration Interval of instruments listed above is one year.

N.C.R. means Non-Calibration required.



4. Measurement Uncertainty

Test Items	Uncertainty	Remark
Conducted Emission (150kHz ~ 30MHz)	2.0 dB	Confidence levels of 95%
Radiated Emission (30MHz ~ 1,000MHz)	3.9 dB	Confidence levels of 95%
Radiated Emission (1GHz ~ 18GHz)	3.9 dB	Confidence levels of 95%
Conducted Emission	1.3 dB	Confidence levels of 95%