

LITE

承認書

SPECIFICATION FOR APPROVAL

客戶名稱(CUSTOMER): 智易科技股份有限公司

品名(DESCRIPTION): RF ANTENNA ASSEMBLY
DIPOLE, BLACK+1. 13CABLE
, GRAY, +IPEX

客戶料號(PART NO): 120300058600J

料號(PART NO): 503021-0113-0BC

送樣日期(DATE): 2020. 10. 29

承認號碼(APPROVED NO):

Liteconn Co., Ltd		Customer Approval	
Prepare	Approval	Check	Approval

堅詠股份有限公司

Liteconn Co., Ltd

Taipei:
Liteconn Co., Ltd
24158新北市三重區中興北街188巷19號
NO. 19 Lane 188, Zhongsing N., St.,
Sanchong Dist, New Taipei City 24158
TEL: 886-2-2995-0485
FAX: 886-2-2995-7395
網址: <http://www.liteconn.com.cn>

ShenZhen:
LiteTek Technology CO., LTD
中國深圳市寶安區松崗街道紅星西坊大田洋工
業園D區
D Avenue, Da Tian Yang Industrial
Area, Hong Xing Xi Fang, Song Gang
Town, Bao'an District Shenzhen
518105, China
TEL: 86-755-2962-6909~17
FAX: 86-755-2962-6919~20

SuZhou:
LiteTek Technology CO., LTD
中國蘇州市吳中區角直鎮機場路39號
(浦澄路口)
NO 39, Airport Road, Luzhi
Town, Wuzhone District, Suzhou, China
TEL: 86-0512-6602-7901~3
FAX: 86-0512-6602-7910

Antenna Type Dipole

120300058600J

Specifications	
Standard	IEEE802.11n and 802.11 a/b/g/ac
Frequency range	2.4 to 2.49GHz , 4.9 to 5.9 GHz
Peak gain	2.35 dBi @ 2.4 GHz
	2.44 dBi @ 5 GHz

Liteconn Co.,Ltd.

APPROVAL INDEX

1 封面	-----	pages	1
2 Antenna Type & Specifications	-----	pages	2
3 目錄	-----	pages	3
4 產品圖及包規	-----	pages	4~5
5 測報	-----	pages	6~12
6 線材資料	-----	pages	13~17
7 端子資料	-----	pages	18~32
8 銅管資料	-----	pages	33~41
9 塑件資料	-----	pages	42~55
10 套管資料	-----	pages	56~63

REV.	FILE No.	DRAWN BY	DATE
X0	TWRFQA1503009	Eva_long	2015.03.12

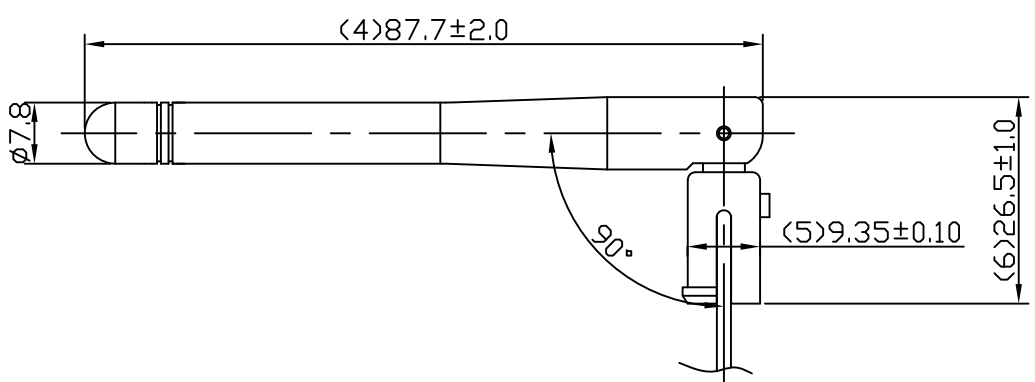
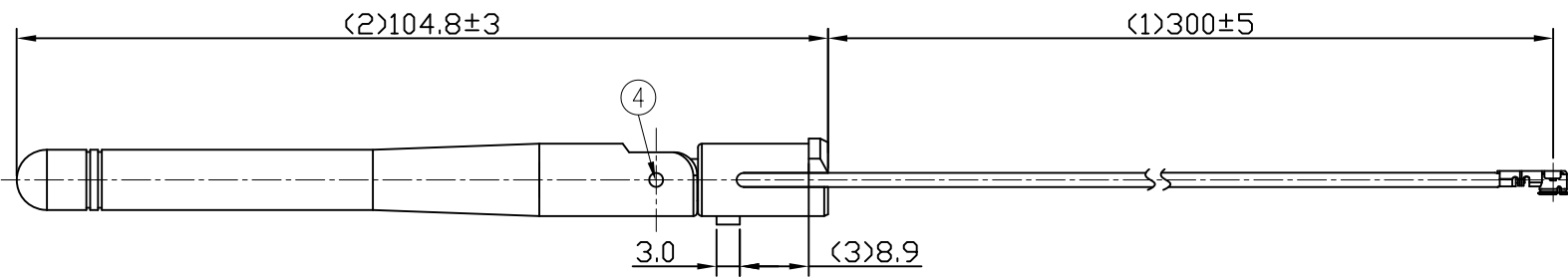
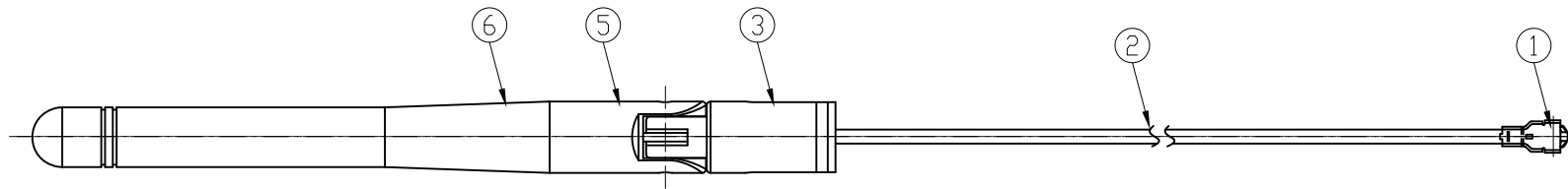

SPECIFICATION:

1. NORMAL IMPEDANCE: 50Ω;
2. FREQUENCY RANGE: 2.4~2.5GHz&5.15~5.825GHZ;
3. VSWR: 2.0Max.;
4. GAIN: 2dBi;
5. 圖面上標有“(*)”符號的尺寸為重點管控尺寸;
6. P/N: ;
7. WEIGHT: g ;
8. MADE IN CHINA.







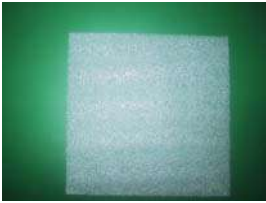

6	ANT. SLEEVE	MATERIAL:TPEE,COLOR:BLACK	1	N/A
5	UPPER BASE	MATERIAL:PC+PBT,COLOR:BLACK	1	N/A
4	REVIT	MATERIAL:PDM,COLOR:BLACK	2	N/A
3	BOTTOM BASE	MATERIAL:PC+PBT,COLOR:BLACK	1	N/A
2	RF CABLE	1.13 CABLE,GRAY	1	N/A
1	RF CONNECTOR	IPEX FOR 1.13 CABLE	1	N/A
ITEM	PART NAME	DESCRIPTION	Q'TY	REMARK

DWG TYPE: CUSTOMER DRAWING		LITE Liteconn Co., Ltd.	
GENERAL TOLERANCE: UNLESS OTHERWISE SPECIFIED		TITLE: RF ANTENNA ASSEMBLY DIPOLE BLACK+1.13 CABLE GRAY+IPEX	
X.X ±0.35	X.X° ±3°	APPD:	DWG No.: 503021-0113-0BC
X.XX ±0.25	X.XX° ±2°	CHECK:	
X.XXX ±0.15	X.XXX° ±1°	DRAW: Eva_long	DATE: 2015.03.12 SCALE: 1:1 UNIT: mm PAGE: 1/1

COMPIANCE WITH THE REQUIREMENT: ✓RoHS; □HF; □SONY SS-00259; □OTHER.
*NO USING RESTRICTED AND BANNED SUBSTANCE

蘇州利慶電子有限公司

包裝作業規範

LITE	標題	包裝作業規範： 純板端天線		備注： ECN NO:EN1101014
文件編號	AAA-CAR-0041	版次	A1	作業說明：
<p>包裝作業示意圖：</p> <div style="display: flex; justify-content: space-around; align-items: flex-start;"> <div style="text-align: center;">  圖1: 成品 </div> <div style="text-align: center;">  圖2: 珍珠棉 </div> <div style="text-align: center;">  圖3: 橡皮筋 </div> </div> <div style="display: flex; justify-content: space-around; align-items: flex-start; margin-top: 20px;"> <div style="text-align: center;">  圖4: 25PCS一扎 </div> <div style="text-align: center;">  圖5: 膠袋 </div> <div style="text-align: center;">  圖6: 裝入膠袋 </div> </div> <div style="display: flex; justify-content: space-around; align-items: flex-start; margin-top: 20px;"> <div style="text-align: center;">  圖7: 封口機封口 </div> <div style="text-align: center;">  圖8: 裝入紙箱 </div> <div style="text-align: center;">  圖9: 每紙箱1000PCS </div> </div>				<ol style="list-style-type: none"> 1. 將檢驗好的成品每25PCS用氣泡棉裹住,再用橡皮筋扎好,如圖1.2.3.4所示. 2. 將25PCS一扎的成品放入膠袋里面,再在每一膠袋中放入一包干燥劑,然後用封口機封好膠袋口,在PE袋上貼上產品料號標籤,如圖5.6.7所示. 3. 將一平板放入紙箱底部,四個角落加上护角,將封好的每一袋成品放入紙箱里面,如圖8所示. 4. 紙箱一層放10袋成品,共250PCS,每紙箱放4層,共1000PCS. 5. 每裝一層放一平板,一箱放5PCS平板,用膠紙封好,貼上相應的標籤.標籤上注明雙方的料號,如圖所示. 6. 再裝上一外箱,并封裝好,打好包裝帶.

核准:

審核:

制定:

測試報告

TEST REPORT

CUSTOMER : 智易

CUSTOMER NO. : 120300058600J

FILE NO : _____

DESCRIPTION : 2.4GHz & 5GHz Antenna

LITE P/N : _____

DATE : 2020/10/26

堅詠股份有限公司

ADD : NO. 19, LANE 188, CHUNG—HSIN N. ST.

SANCHUAN, TAIPEI HSIEN, TAIWAN R.O.C

TEL : (886-2) 2995-0485

FAX : (886-2) 2995-7395

[http : //www.liteconn.com](http://www.liteconn.com)



堅詠股份有限公司

Liteconn Co., Ltd.

TEL:+886-2-2995-0485 FAX:+886-2-2995-7395 <http://www.liteconn.com>

CONNECTOR & RF ANTENNA

Test time : 2020/10/26

Company : 智易

Model :

Project : 2.4G & 5G ANTENNA

Photo :

場型量測示意圖

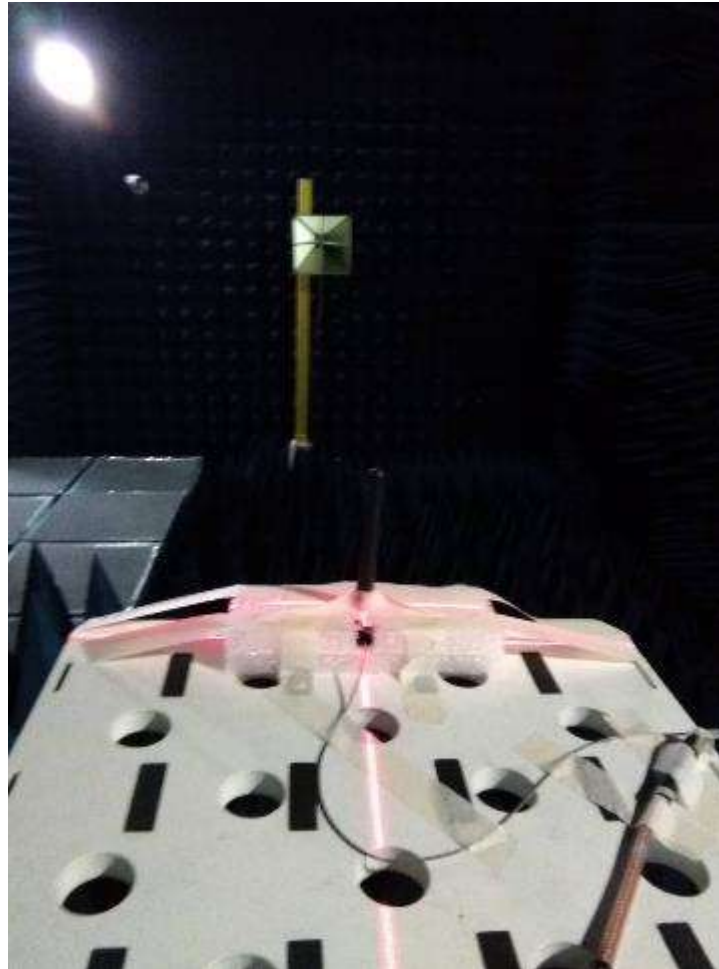
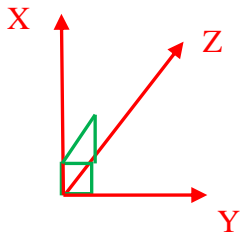



堅詠股份有限公司

Liteconn Co., Ltd.

TEL:+886-2-2995-0485 FAX:+886-2-2995-7395 <http://www.liteconn.com>

CONNECTOR & RF ANTENNA

Test time : 2020/10/26

Company : 智易

Model :

Project : 2.4G & 5G ANTENNA

Photo :

網儀量測示意圖





堅詠股份有限公司

Liteconn Co., Ltd.

TEL:+886-2-2995-0485 FAX:+886-2-2995-7395 http://www.liteconn.com

CONNECTOR & RF ANTENNA

Test time : 2020/10/26

Company : 智易

Model :

Project : 2.4G & 5G ANTENNA

Photo :

ANTENNA 1

Return Loss & VSWR & Smith

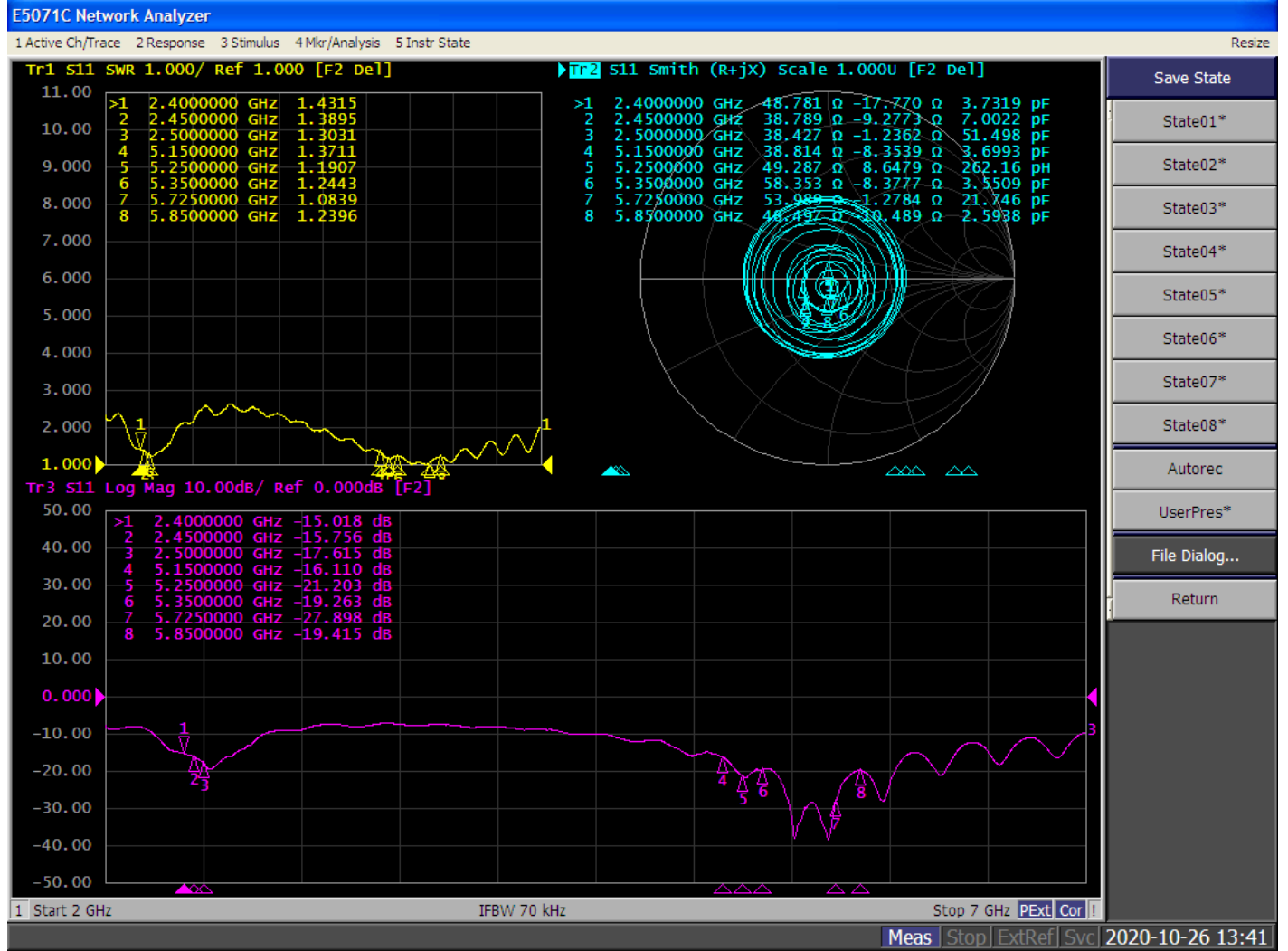

Test time : 2020/10/26

Company : 智易

Model :

Project : 2.4G & 5G ANTENNA

Photo :

ANTENNA 1
3D Radiation Pattern

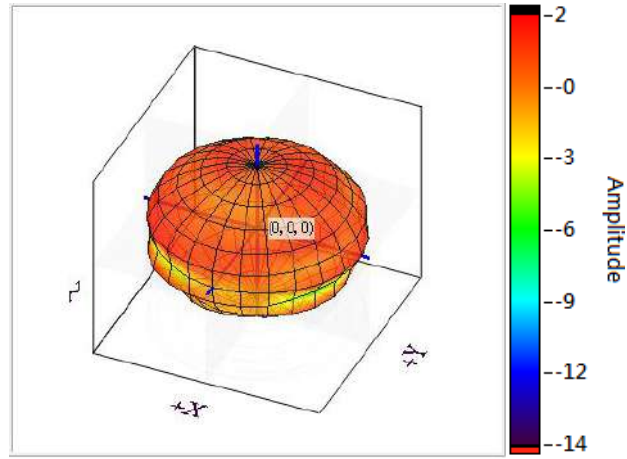

2400 MHz

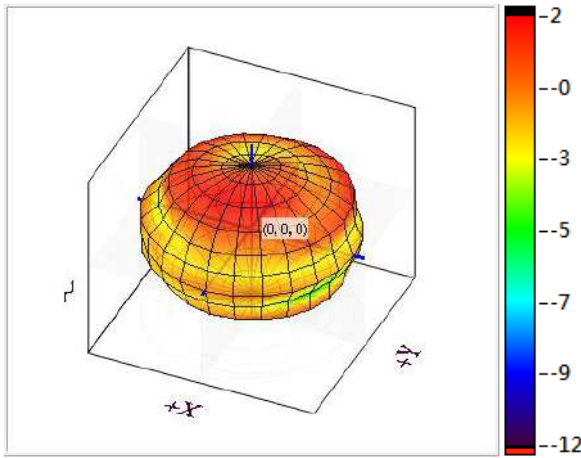

2450 MHz

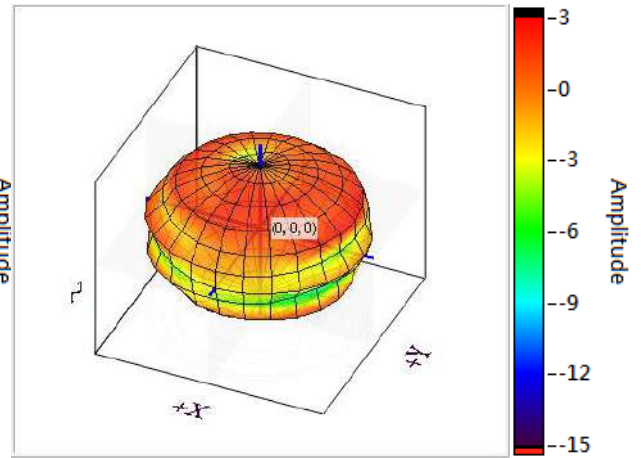

2500 MHz

3D Antenna Gain

Frequency (MHz)	Peak Gain (dBi)	Efficiency (%)
2400	2.14	56.63
2450	2.06	53.7
2500	2.35	59.68

Test time : 2020/10/26

Company : 智易

Model :

Project : 2.4G & 5G ANTENNA

Photo :

ANTENNA 1
3D Radiation Pattern

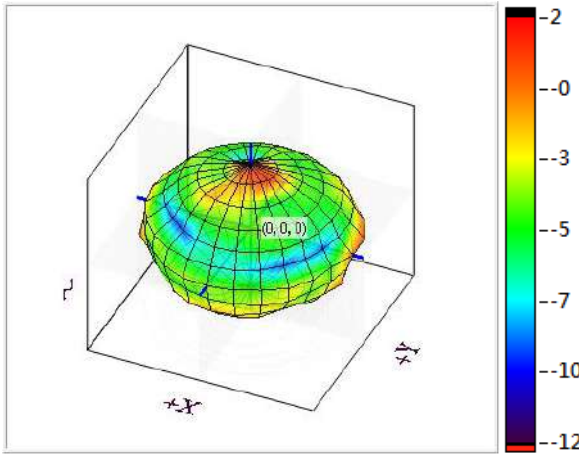

5150 MHz

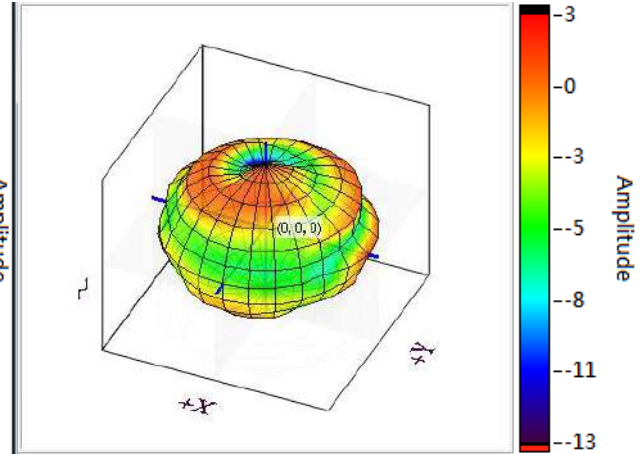

5250 MHz

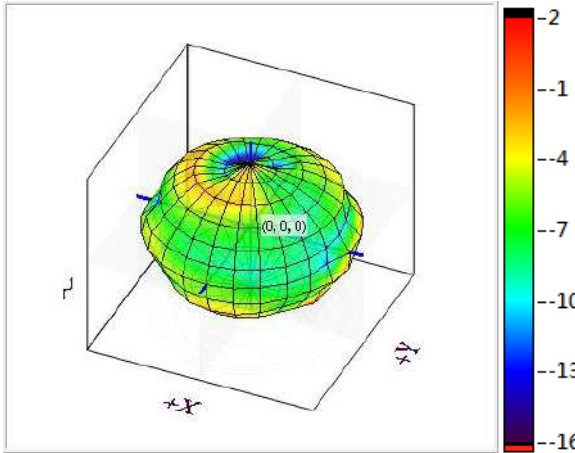

5350 MHz

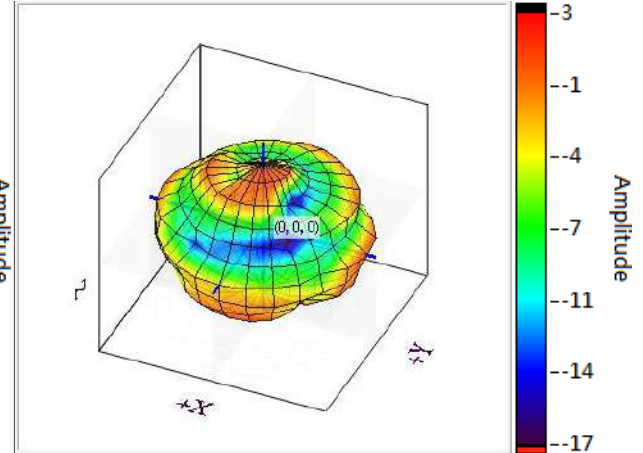

5725 MHz

Test time : 2020/10/26

Company : 智易

Model :

Project : 2.4G & 5G ANTENNA

Photo :

ANTENNA 1
3D Radiation Pattern

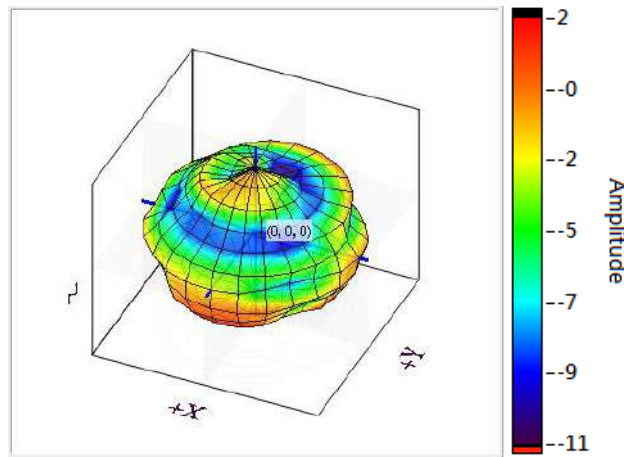

5850 MHz

3D Antenna Gain

Frequency (MHz)	Peak Gain (dBi)	Efficiency (%)
5150	1.97	47.27
5250	2.24	51.11
5350	2.16	50.6
5725	2.44	55.99
5850	2.03	49.31

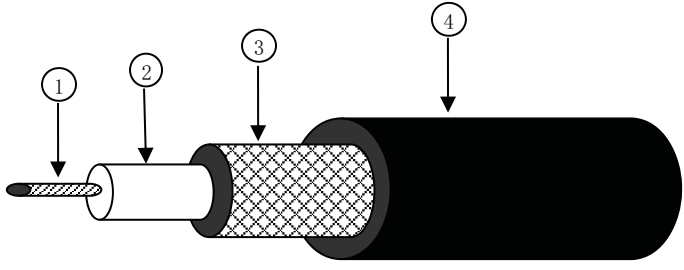
电缆名称		RF1.13	
结构 Structure	项目 Item	标准值 Standard value	
①内导体 inner conductor	材料 Material	镀锡铜丝 tinned copper wire	
	组成: 总根数/单根外径 (mm) Makeup: total/O.D.ofevery wire (mm)	7/0.08 ± 0.003mm	
	(绞合) 标准外径 (mm) (intertwist) NOM. O. D. (mm)	0.24 ± 0.02mm	
②绝缘层 Insulation	材料 Material	聚全氟乙丙烯 (FEP)	
	颜色 colour	透明 clarity	
	标准外径 (mm) NOM. O. D. (mm)	0.682 ± 0.05mm	
③外导体 outer conductor	材料 Material	镀锡铜丝 tinned copper wire	
	组成: 总根数/单根外径 (mm) Makeup: total/O.D.ofevery wire (mm)	16*4/0.05	
	标准外径 (mm) NOM. O. D. (mm)	0.91 ± 0.03mm	
	覆盖率 (%) coverage ratio (%)	91 ± 5	
④护套 jacket	材料 Material	聚全氟乙丙烯 (FEP)	
	颜色 colour	/	
	标准外径 (mm) NOM. O. D. (mm)	1.13 (+0.07mm-0.03mm)	
电性能特性 Electrical characteristics		机械特性 mechanical properties	
项目 Item	标准值 Standard value	项目 Item	标准值 Standard value
1. 阻抗 Impedance	50 ± 2 Ω	1. 恒定温度 steady temperature	-55~+200℃
2. 电容 Capacitance	97pF/m	2. 最小弯曲半径 minimum bending radius	12mm
3. 驻波比 Standing wave ratio	≤ 1.3@0~6GHz	3. 最大拉伸强度 maximum tensile strength	0.6kg
4. 速率 Velocity	70%	4. 线缆重量 Cable weight	3.2g/m
5. 最大工作电压 Max.operating voltage	1000V	5. 额定温度 rated temperature	150℃
6. 最大工作频率 Max.operating frequency	6GHz	/	/
截面图		包装 Packing	
		项目 Item	标准值 Standard value
		包装方式 Packing mode	纸盘 Papery plate
		每盘长度 The length of each plate	1000m
		每盘接头数 Each connector plate number	≤ 3
		每段最短长度 The shortest length of each root	≥ 10
使用提示 Use tips			
存储环境 Storage environment	温度: 30℃以下; 湿度: 20%~65%		
最佳保存周期 The best save cycle	2个月; 2个月以上作业性下降, 如上锡效果变差, 但电性能不受影响。夏季高温高湿环境开剥后需尽快流转		
加工温度 Processing temperature	260℃的极限情况下, 可短时间承受; 300℃以上分子通常带有的等端基会分解; 400℃以上发生显著的热分解		
铁氟龙收缩 Teflon Shrink	固有材料特性。绝缘: 0.2mm以下; 护套: 0.3mm以下		
护套窜动 Jacket traverse	加工长度 (护套残留长度) 低于5cm易发生		

上海康成铜业集团有限公司

地址：上海市松江区大江路 99 号
电话：021-31271079

邮编：201600
传真：31271122

材质报告

QR8.2.4-02
№ 15073101

客户名称	正旭	出厂日期	2015.7.31
产品名称	镀锡圆铜线	型号/规格	Φ 0.05 mm
批 号	150731	重 量	150.82 kg
抽样数量	10 轴	合格数量	10 轴
检验项目	标准值	实测值	判 定
外观	表面光洁、无氧化、刮伤等 与良好工业品不相符的缺陷		
直径mm	0.05±0.003	0.049~0.05	OK
20℃电阻率Ω mm ² /m	≤0.01850	0.01715~0.01738	OK
伸长率%	≥15	16~19	OK
排线	整齐、紧密、均匀	OK	OK
铜的成分%	Cu+ Sn ≥99.95 Fe<0.0025 Ni<0.0020 Sn<0.0025 Zn<0.0020 Bi<0.0006 Sb<0.0004 As<0.0005 S<0.0025	Cu+ Sn ≥99.96 Fe=0.0004 Ni=0.0004 Sn=0.0008 Zn=0.0003 Bi=0.0003 Sb=0.0003 As=0.0003 S=0.0008	
备注	1. 《电工圆铜线》GB3953-2009 《镀锡圆铜线》GB/T4910-2009 2. 《抽样计划》参照 GB2828-87 依《MIL-STD-105E》一般检验水准 II 级进行 抽样检验。 3. 本产品制程及材料符合 RoHS 及 REACH 相关规定		
综合判定			

检验员：靳春娟

审核：桂志平

日期：2015.7.31

上海康成铜业集团有限公司

SHANGHAI KANCHENG COPPER GROUP CO., LTD.

No.99 Dajiang Rd. High Technology Zone, Songjiang, Shanghai, China. Contact Person: Mr. Michael Chen

TEL:+86-21-31271079

FAX:+86-21-31271122

物质安全资料表 (MSDS)

KC130101

1. 物料及企业标识

产品名称 铜锡合金线
制造商 上海康成铜业集团有限公司
地址 上海市松江区高新科技园区大江路 99 号
电话 021—31271080 021—3127017
传真 021—31271122

2. 材料组成和成分信息

单一产品或混合物 单一产品
含量 铜+锡≥99.95
危害不纯物 无

3. 危险标识

健康危害效应 无
环境影响 无
物理及化学危害 无
特殊危害 无

4. 急救措施

无特别危险性，避免用手或脏东西直接接触，以免引起表面氧化；避免撞伤或刮伤

5. 消防措施

适用灭火剂 水、泡沫、干粉（不易燃烧）

6. 意外释放措施

无特别危险性防护设施

7. 操作和储存

操作处所避免油污。

储存 存放于干燥处，避免阳光直射、雨淋、高温，以免引起氧化。

8. 暴露控制/个人防护

常温下使用无特别要求

9. 物理和化学特性

比重 8.9~8.94
颜色 紫铜色
气味 无
状态 线状
熔点 1083℃

10. 稳定性/反应

长期置于空气中会氧化无刺激性、无毒性、无危害性分解物。

11. 毒理学信息

无毒

12. 生态信息

可能的环境影响/ 环境流布：无资料

13. 处置注意事项

应该考虑为了安全和环境问题所推荐的首选处理方法）：导致排放废弃物及有关废弃物处理的法律以及当地废弃物处理之规定处理。

14. **（运输资料）**

避免与酸性碱性物品共同运输。

15. 法规信息

适用法规：无资料

16. 其他信息

符合欧盟 ROHS 指令，符合 REACH 法规要求及环保要求。

制表部门：质保部

制表人： 桂志平

制表日期：2013. 8. 28



July 01, 2014

To: JIANHUA FENG
SUZHOU XIANGCHENG ZHENGXU WIRES AND CABLES CO LTD
Email: zzg@zhxdz.com

Subject: Follow-Up Testing Completed - Conforming Results
Sample Tag #: F133608, 11149
File #: E365708, Vol. #: 1
CCN: AVLV2, Appliance wiring material - component

Dear Sir / Madam:

Please Note: This letter is automatically sent when sample tag is completed with Conforming results.

Any information and documentation involving UL Mark services are provided on behalf of UL LLC (UL) or any authorized licensee of UL.

The Follow-Up Services Testing has been completed on the Appliance wiring material - component, 11149 selected by our UL Representative at your SUZHOU XIANGCHENG ZHENGXU WIRES AND CABLES CO LTD, SUZHOU JIANGSU, China factory on May 15, 2014.

Please see below an itemized list of test(s) performed under the above referenced Tag.

HORIZONTAL-SPECIMEN APPLIANCE-WIRE FLAME TEST

Your continued cooperation in maintaining conformance with the applicable test requirements is appreciated.

If we can be of any further assistance, please do not hesitate to contact Xiao-lan Zhou at +86 512 6875 8537, Ext. 66537, or via email at FUSAdmin.SUZ@ul.com.

Note: Should any of your FUS Sample Testing contact information change, please let us know so our records can be updated.

CC:

No.06027-1
Feb / 26/'08

材料証明書
MATERIAL CERTIFICATE

当社製品には下記の材料が使われている事を証明致します。

WE HEREBY CERTIFY THAT THE FOLLOWING MATERIALS ARE USED IN OUR PRODUCT.

PRODUCT NAME : MHF series micro coaxial connector PLUG & RECEPTACLE VERTICAL

Plug, Non halogen free type

Part No.	Contents	Housing	Contact	Ground contact
20278-101R-08	材質名/ Material	PBT	Phosphor bronze	Phosphor bronze
20278-111R-08				
20278-101R-13	型名/ Cat No.	DURANEX 3116	C5210R-H	C5191R-1/2H
20278-111R-13				
20278-101R-32	材料メーカー	WINTECH POLYMER LTD.	Nippon Mining &	HARADA METAL
20278-111R-32	Manufacturer		Metals Co.,Ltd.	INDUSTRY Co.,Ltd.
20278-101R-18				
20278-111R-18	UL94難燃性	V-0	-----	-----
20308-101R-13	UL94 flame			
20308-111R-13	class			
20308-101R-32				
20308-111R-32	UL file No.	E213445	-----	-----
20351-101R-37				
20351-111R-37				

※添付資料 : ULカード写し/UL CARD COPY

APPROVAL	CHECK	ORIGINATOR
T.Harada Feb/26/'08	T.Tagawa Feb/26/'08	K.Ohbayashi Feb/26/'08

Plug, Halogen free type

Part No.	Contents	Housing	Contact	Ground contact
20278-102R-08	材質名/ Material	PBT	Phosphor bronze	Phosphor bronze
20278-112R-08	型名/ Cat No.	XFR4840 GF10	C5210R-H	C5191R-1/2H
20278-102R-13	材料メーカー	WINTECH POLYMER LTD.	Nippon Mining & Metals Co.,Ltd.	HARADA METAL INDUSTRY Co.,Ltd.
20278-112R-13	Manufacturer			
20278-102R-32	UL94難燃性	V-0	-----	-----
20278-112R-32	UL94 flame			
20278-102R-18	class			
20278-112R-18	UL file No.	E213445	-----	-----
20351-102R-37				
20351-112R-37				

※添付資料：ULカード写し／UL CARD COPY

Receptacle

Part No.	Contents	Housing	Contact	Ground contact
20279-001E-01	材質名/ Material	LCP	Brass	Phosphor bronze
20314-001E-01	型名/ Cat No.	VECTRA E130i	C2680R-o	C5191R-1/2H
	材料メーカー	Polyplastics Co.,Ltd	Nippon Mining & Metals Co.,Ltd.	HARADA METAL INDUSTRY Co.,Ltd.
	Manufacturer			
	UL94難燃性	V-0	-----	-----
	UL94 flame			
	class			
	UL file No.	E 106764	-----	-----

※添付資料：ULカード写し／UL CARD COPY

QMFZ2 Component – Plastics

Friday, October 24, 2003

E213445

WINTECH POLYMER LTD

18-1 KONAN 2-CHOME MINATO-KU TOKYO 108-8280 JP

Material Designation: **3116(e)**

Product Description: Polybutylene Terephthalate (PBT), designated "Duranex" furnished as pellets.

Color	Min. Thick. (mm)	Flame Class	HWI	HAI	RTI Elec	RTI Imp	RTI Str	IEC GWIT	IEC GWFI
ALL	0.75	V-0	4	0	130	–	130	–	–
	1.5	V-0	3	0	130	120	130	–	–
NC, BK	3	5VA	2	0	130	120	130	–	–
CTI: 2	IEC CTI (V): –	HVTR: 3			D495: 6			IEC Ball Pressure (° C): –	
Dielectric Strength (kV/mm): 23		Volume Resistivity (10⁹ohm-cm): 16						Dimensional Stability(%):0.0	
ISO Tensile Strength (MPa): –		ISO Flexural Strength (MPa): –						ISO Heat Deflection (C): –	
ISO Tensile Impact (kJ/m²): –		ISO Izod Impact (kJ/m²): –						ISO Charpy Impact(kJ/m²): –	

(e) Virgin and regrind from 1 to 50 by weight incl. have the same basic material characteristics (at a minimum thickness of 0.75 mm), except for 310EP which has a lower as received Tensile Impact value from 26 to 50 percent regrind.

Report Date: 11/15/2000

Underwriters Laboratories IncR

UL94 small-scale test data does not pertain to building materials, furnishings and related contents. UL 94 small-scale test data is intended solely for determining the flammability of plastic materials used in components and parts of end-product devices and appliances, where the acceptability of the combination is determined by ULI.

Component - Plastics

E213445

WINTECH POLYMER LTD

18-1 KONAN 2-CHOME, MINATO-KU, TOKYO 108-8280 JP

XFR 4840 GF10

Polybutylene Terephthalate (PBT), "Duranex", furnished as pellets

Color	Min Thk (mm)	Flame Class	HWI	HAI	RTI Elec	RTI Imp	RTI Str
ALL	0.75	V-0	1	0	75	75	75
	1.5	V-0	1	0	75	75	75
	3.0	V-0	1	0	75	75	75

Comparative Tracking Index (CTI): **1**

Dimensional Stability (%): -

High-Voltage Arc Tracking Rate
(HVTR): **0**High Volt. Low Current Arc Resis (D495): **5**Dielectric Strength (kV/mm): **24**Volume Resistivity (10xohm-cm): **14**

UL94 small-scale test data does not pertain to building materials, furnishings and related contents. UL94 small-scale test data is intended solely for determining the flammability of plastic materials used in the components and parts of end-product devices and appliances, where the acceptability of the combination is determined by ULI.

Report Date: 2006-07-24

Last Revised: 2006-07-25

Underwriters Laboratories Inc®

**IEC and ISO Test Methods**

Test Name	Test Method	Units	Thickness	
			Tested (mm)	Value
IEC Flammability	IEC 60695-11-10	Class (color)	0.75	V-0 (ALL)
			1.5	V-0 (ALL)
			3.0	V-0 (ALL)
Glow-Wire Flammability (GWFI)	IEC 60695-2-12	C	-	-
Glow-Wire Ignition (GWIT)	IEC 60695-2-13	C	-	-
IEC Comparative Tracking Index	IEC 60112	Volts (Max)	-	-
IEC Ball Pressure	IEC 60695-10-2	C	-	-
ISO Heat Deflection (1.80 MPa)	ISO 75-2	C	-	-
ISO Tensile Strength	ISO 527-2	MPa	-	-
ISO Flexural Strength	ISO 178	MPa	-	-
ISO Tensile Impact	ISO 8256	kJ/m2	-	-
ISO Izod Impact	ISO 180	kJ/m2	-	-
ISO Charpy Impact	ISO 179-2	kJ/m2	-	-

Underwriters Laboratories Inc®

QMFZ2 Component - Plastics

Friday, October 24, 2003

E106764

POLYPLASTICS CO LTD

VECTRA DIV 18-1 KONAN 2-CHOME MINATO-KU TOKYO 108-8280 JAPAN

Material Designation: **E130i(d)(e)**

Product Description: Liquid Crystal Polymer (LCP), thermotropic aromatic polyester, designated "Vectra" furnished as pellets.

Color	Min. Thick. (mm)	Flame Class	HWI	HAI	RTI Elec	RTI Imp	RTI Str	IEC GWIT	IEC GWFI
ALL	0.75	V-0	2	4	240	220	240	-	-
	1.5	V-0	1	4	240	220	240	-	-
	3.0	V-0	0	4	240	220	240	-	-

CTI: 4

HVTR: 0

D495: 5

IEC Ball Pressure (°C): -

Dielectric Strength (kV/mm): 39

Volume Resistivity (10⁸ohm-cm): 16

Dimensional Stability(%): 0

ISO Tensile Strength (MPa): -

ISO Flexural Strength (MPa): -

ISO Heat Deflection (°C): -

ISO Tensile Impact (kJ/m²): -

ISO Izod Impact (kJ/m²): -

ISO Charpy Impact (kJ/m²): -

(d) Virgin and regrind up to 50% by weight incl. have the same basic material characteristics for colors NC and BK.

(e) In addition, regrind at 26 to 50% have the same basic characteristics at a minimum of 1.5mm except RTI's for the Mechanical w/Impact property is 180C.

Report Date: 8/19/1992

Underwriters Laboratories Inc®

UL94 small-scale test data does not pertain to building materials, furnishings and related contents. UL 94 small-scale test data is intended solely for determining the flammability of plastic materials used in components and parts of end-product devices and appliances, where the acceptability of the combination is determined by ULI.

PART NO.
20278-...R...

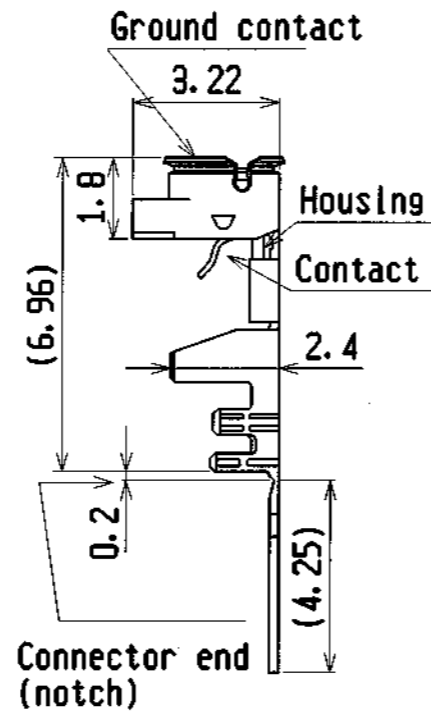
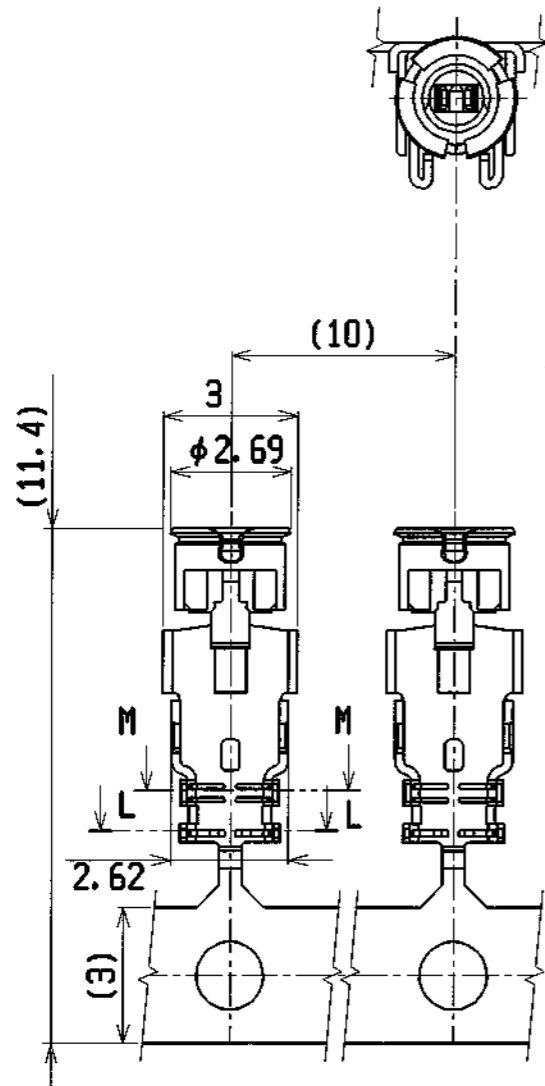

Part No. 20278-101R-08
20278-102R-08
20278-101R-13
20278-102R-13
20278-101R-32
20278-102R-32

For hand tool
(with notch)

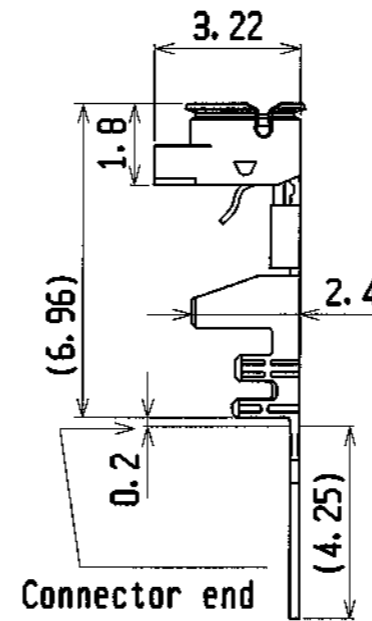

Part No. 20278-111R-08
20278-112R-08
20278-111R-13
20278-112R-13
20278-111R-32
20278-112R-32

For semi auto
termination machine
(without notch)

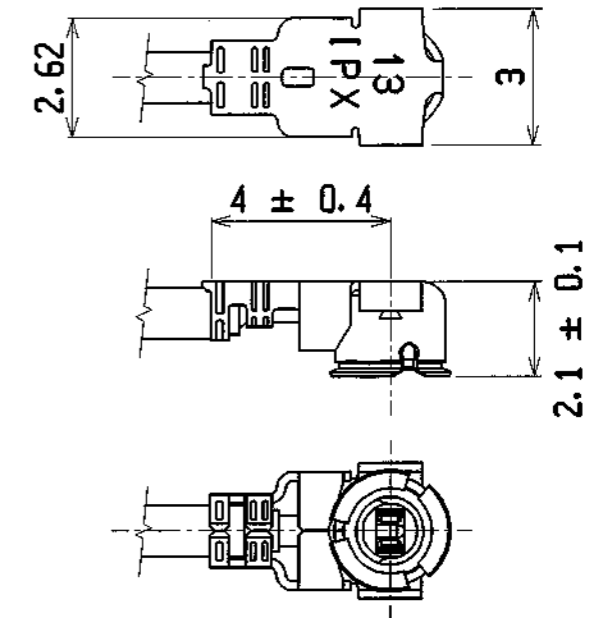

Cable Ass'y

Plug
P/N 20278-1...R-08
P/N 20278-1...R-13
P/N 20278-1...R-32

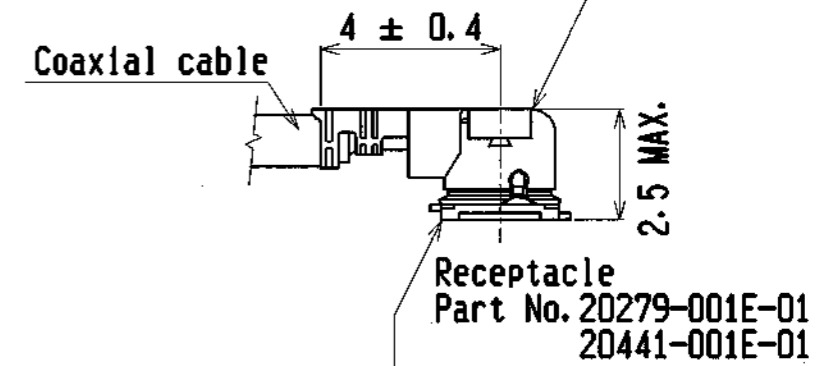

MATING

GENERAL TOLERANCE		
6 MAX.	±0.2	
6 OVER MAX. 30	±0.3	
30 OVER MAX. 120	±0.5	
ANGLE	±2°	

19C 208056	K.O	Feb/04/08	EK	DESIGN'D BY	DATE
18C 207346	K.O	Jul/10/08	E.K	K. Ohbayashi	JUN/13/01
17C 205233	K.O	May/18/05	T.H	CHK'D BY	DATE
16C 205024	K.O	Jan/20/05	T.H		
15C 204398	K.O	Nov/12/04	T.H	APP'D BY	DATE
REV ECN	BY	DATE	APP	K. Katabuchi	JUN/13/01
REV. RECORD				CUSTOMER COPY	PROJECTION
SERIES No. 2814					

I-PEX		Interconnect and Packaging Electronics TOKYO, JAPAN	
TITLE MF series micro coaxial connector plug vertical (ground contact : gold plating)			General
SCALE	UNIT	DWG. No.	SHEET REV.
6/1	mm	20278	1/4 19C

PART NO.
20278-***R-***

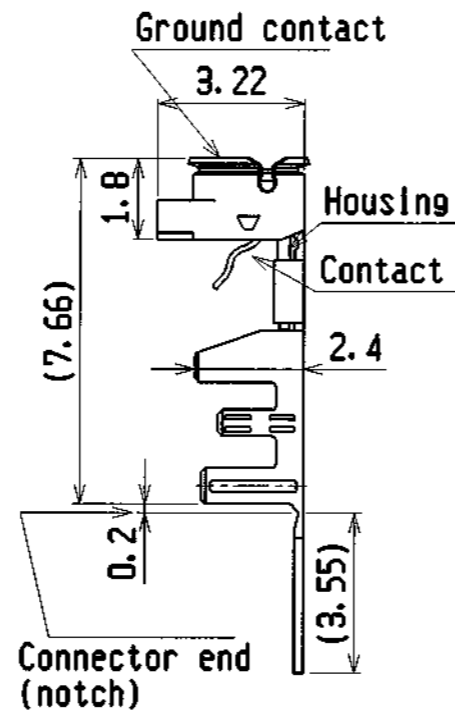
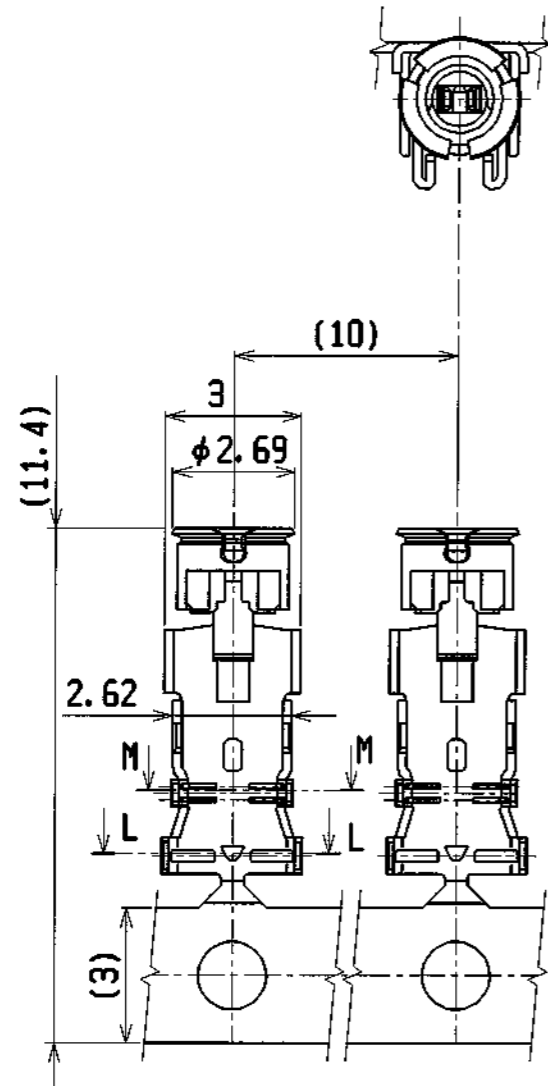

Part No. 20278-101R-18
20278-102R-18
For hand tool
(with notch)

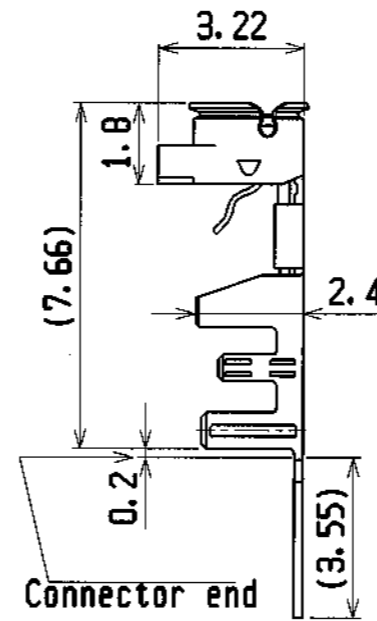

Part No. 20278-111R-18
20278-112R-18
For semi auto
termination machine
(without notch)

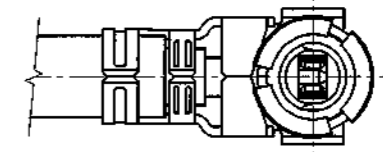
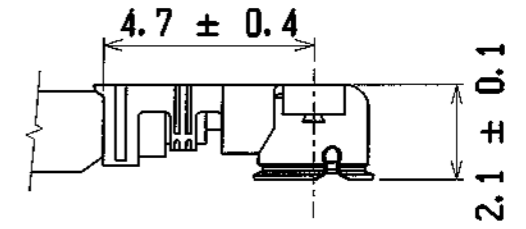
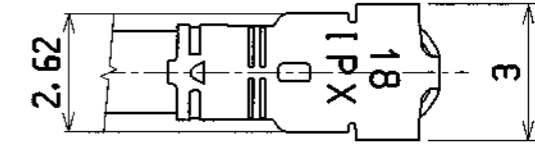

Cable Ass'y

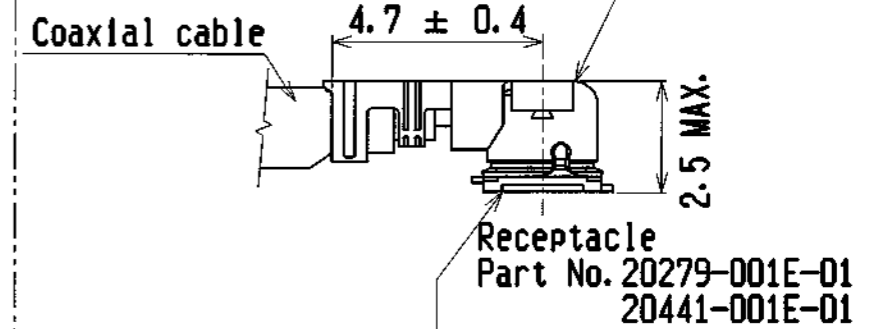

Plug
P/N 20278-1**R-18



MATING

GENERAL TOLERANCE	
6 MAX.	±0.2
6 OVER MAX. 30	±0.3
30 OVER MAX. 120	±0.5
ANGLE	±2'

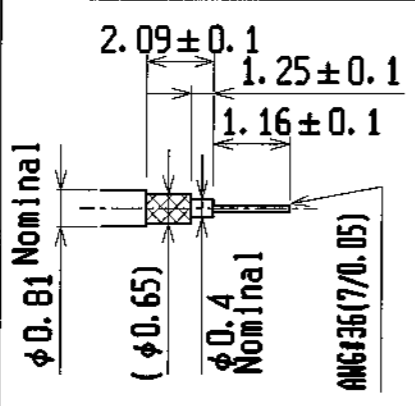
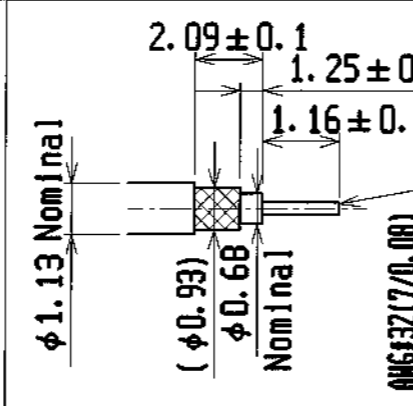
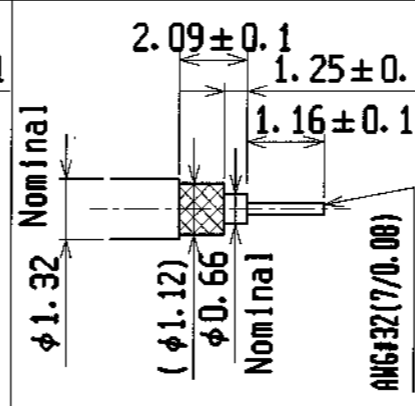
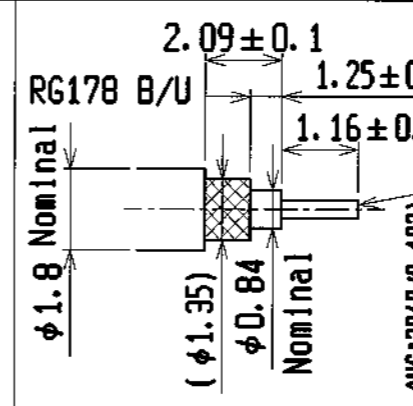
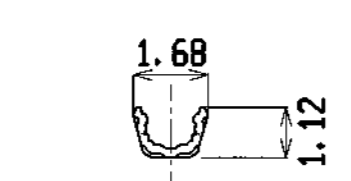
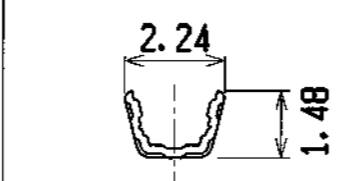
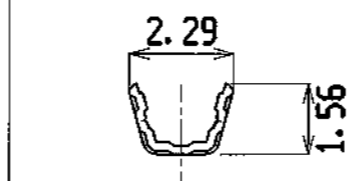
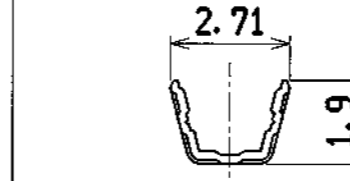
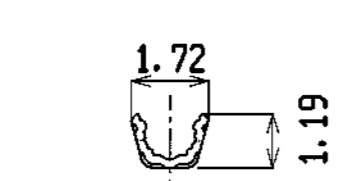
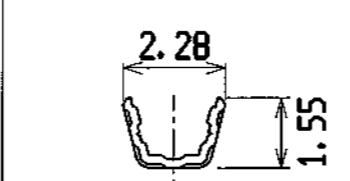
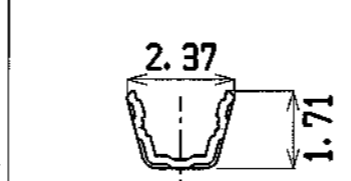
DESIGN D BY	DATE	I-PEX Interconnect and Packaging Electronics TOKYO, JAPAN	TITLE MNF series micro coaxial connector plug vertical (ground contact : gold plating)	General							
CHK D BY	DATE										
APP D BY	DATE										
REV	ECN	BY	DATE	APP	CUSTOMER COPY	PROJECTION	SCALE	UNIT	DWG. No.	SHEET	REV.
							6/1	mm	20278	2/4	19C
REV. RECORD					SERIES No.						
					2814						

Part No. of non halogen free type	20278-101R-08 20278-111R-08	20278-101R-13 20278-111R-13	20278-101R-32 20278-111R-32	20278-101R-18 20278-111R-18	
Part No. of halogen free type	20278-102R-08 20278-112R-08	20278-102R-13 20278-112R-13	20278-102R-32 20278-112R-32	20278-102R-18 20278-112R-18	
Housing color	White	Black	Black	White	
Applicable cable nominal dimension	 2.09 ± 0.1 1.25 ± 0.1 1.16 ± 0.1 $\phi 0.81$ Nominal $(\phi 0.65)$ $\phi 0.4$ Nominal ANG#35(7/0.05)	 2.09 ± 0.1 1.25 ± 0.1 1.16 ± 0.1 $\phi 1.13$ Nominal $(\phi 0.93)$ $\phi 0.68$ Nominal ANG#32(7/0.08)	 2.09 ± 0.1 1.25 ± 0.1 1.16 ± 0.1 $\phi 1.32$ Nominal $(\phi 1.12)$ $\phi 0.66$ Nominal ANG#32(7/0.08)	 RG178 B/U 2.09 ± 0.1 1.25 ± 0.1 1.16 ± 0.1 $\phi 1.8$ Nominal $(\phi 1.35)$ $\phi 0.84$ Nominal ANG#30(7/0.102)	
Braided shield of Outer conductor 外部導体の編組	Single / 1重編組	Single / 1重編組	Double / 2重編組	Single / 1重編組	
P/N of hand Tool	90187-008C	90187-013C	90187-032C	90233-018	
P/N of semi auto termination machine	90213-008C	90213-013C	90213-032C	90232-018	
Sect. M-M	 1.68 1.12	 2.24 1.48	 2.29 1.56	 2.71 1.9	
Sect. L-L	 1.72 1.19	 2.28 1.55	 2.37 1.71	 3.1 2.26	
Crimp Height	CH-1	1.34~1.40	1.34~1.40	1.34~1.40	1.34~1.40
	CH-2	0.76~0.84	1.06~1.14	1.20~1.30	1.41~1.49
	CH-3	0.85~0.97	1.15~1.35	1.26~1.46	1.70~1.80

Cable cut length

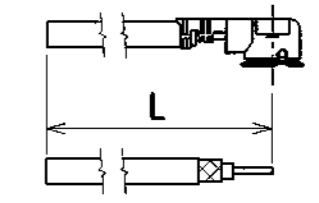

Crimp Height

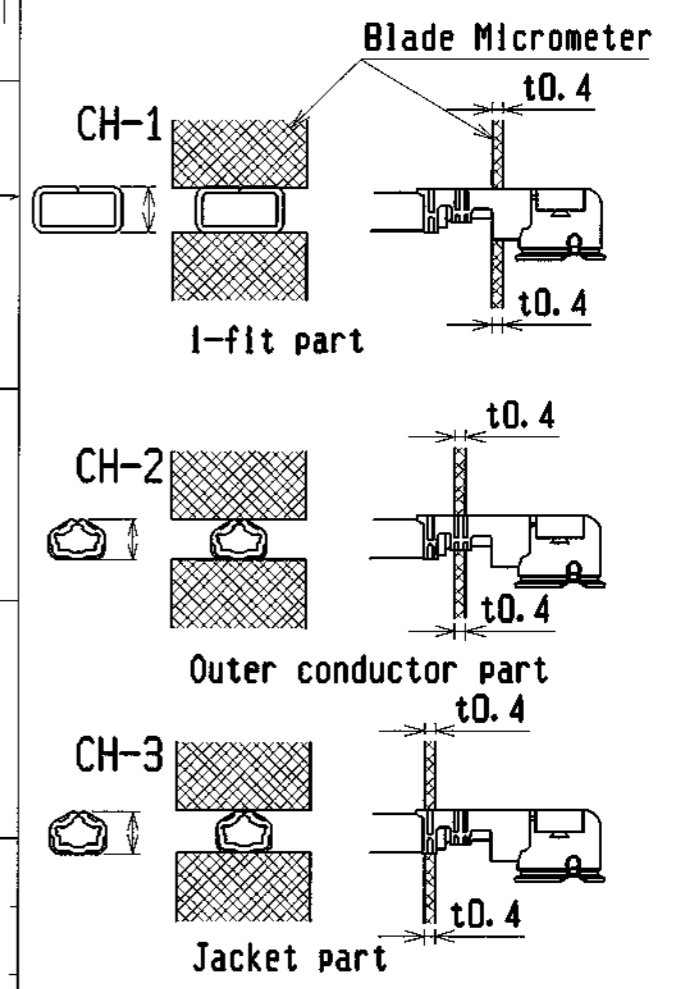

NOTE-1
 中心導体, 外部導体への半田コーティングは不可
 Must not use solder coated
 inner conductor and outer conductor.

DESIGN D BY	DATE	 I-PEX Interconnect and Packaging Electronics TOKYO, JAPAN	TITLE NHF series micro coaxial connector plus vertical (ground contact : sold plating) General					
CHK D BY	DATE							
APP D BY	DATE							
REV	ECN	BY	DATE	APP	SCALE UNIT --/-- mm	DWG. No. 20278	SHEET 3/4	REV. 19C
REV. RECORD SERIES No. 2814								

Notes

1. Material

- (1) Housing : PBT , UL94V-0
- (2) Contact
phosphor bronze
gold plating 0.1 μ m MIN.
over nickel 1.27 μ m MIN.
- (3) Ground contact
phosphor bronze
gold plating 0.05 μ m MIN.
over nickel 1.27 μ m MIN.

2. Packing : reel

3. Mating partner part No.
: 20279-001E-01, 20441-001E-01

4. Permissible load of cable at mating

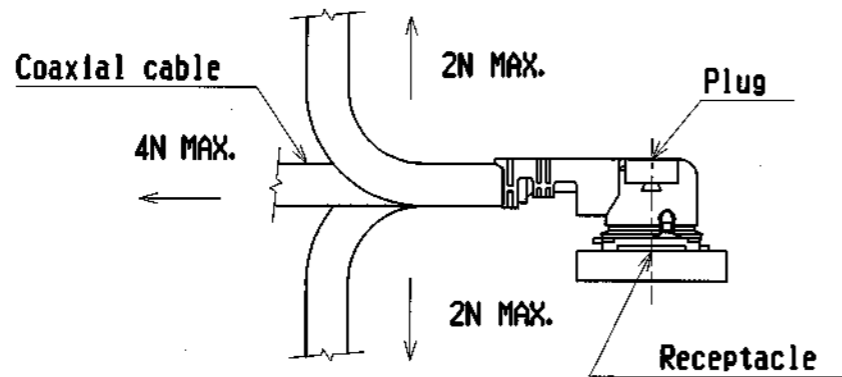

5. Suggestions for mating & unmating operation.

5-1 Mating.

Please mate the connector straightly to vertical direction as much as possible, adjusting the mating axis of plug and receptacle. As excessive slant angle mating may break the connector, please don't do it.

1. 材料

- (1) ハウジング : PBT, UL94V-0
- (2) コンタクト
りん青銅
金メッキ0.1 μ m MIN.
下地 ニッケル1.27 μ m MIN.
- (3) グランドコンタクト
りん青銅
金メッキ0.05 μ m MIN.
下地 ニッケル1.27 μ m MIN.

2. 梱包 : リール

3. かん合相手 part No.
: 20279-001E-01, 20441-001E-01

4. コネクタかん合後のケーブルに対する荷重

5. コネクタかん合時および抜去時の注意

5-1 コネクタ挿入時

PlugとReceptacleのかん合軸を合わせ、できるだけ垂直に挿入して下さい。極端な斜め挿入は行わないで下さい。コネクタ破損の原因となりますので、過度なこじり挿入は行わないで下さい。

5-2 Unmating.

- (1) In case of unmating by pulling tool.
Please use the pulling tool as the following drawing, and please pull plug to vertical direction as directly as possible.

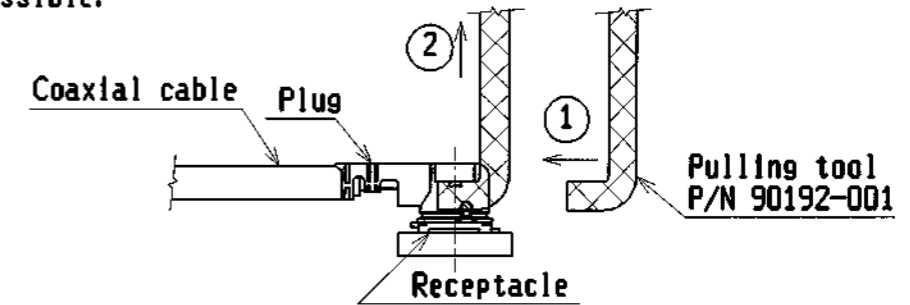

- (2) In case of unmating directly by hand
Please catch the catching area of plug, and please pull plug to vertical direction as directly as possible.

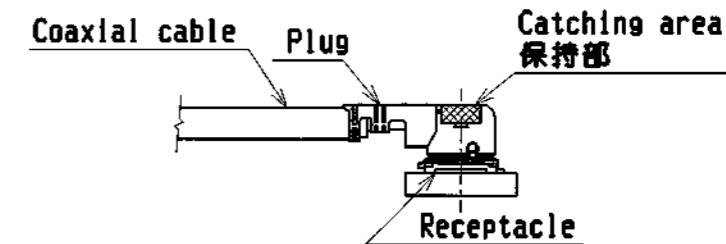

5-2 コネクタ抜去時

- (1) 抜去ジグを用いる場合
下図のようにできるだけ垂直に引き抜いて下さい。

- (2) 手で直接引き抜く場合
下図の保持部をつかみ、できるだけ垂直に引き抜いて下さい。

5-3 Crimp over standards of outer conductor

Standards: Less than 10% from total numbers of outer conductor
(Numbers of outer conductor's crimp over from outer conductor's barrel)

5-4 Caution about Heat shrinkage tubes

Please be careful not to melt housing when using heat shrinkage tubes. It will become cause of open circuit.

6. This is 'Pb-free' connector.

5-3 外部導体はみ出し量



外部導体はみ出し量規定
: 外部導体トータル本数の10%以下
(外部導体パレルの外にはみ出し量)

5-4 熱収縮チューブについての注意

熱収縮チューブで外部導体を覆う場合は、導通不良の原因となりますので、熱によりハウジングを溶融させないように注意してください。

6. 本コネクタは'Pb-free'である

GENERAL TOLERANCE	
6 MAX.	±0.2
6 OVER MAX. 30	±0.3
30 OVER MAX. 120	±0.5
ANGLE	±2°

					DESIGN'D BY	DATE	 Interconnect and Packaging Electronics TOKYO, JAPAN				
					CHK'D BY	DATE					
					APP'D BY	DATE					
REV	ECN	BY	DATE	APP	TITLE		MF series micro coaxial connector plug vertical (ground contact : gold plating)				
REV. RECORD					CUSTOMER COPY	PROJECTION	SCALE	UNIT	OWG. No.	SHEET	REV.
SERIES No. 2814							-/-	mm	20278	4/4	19C

MATERIAL SAFETY DATA SHEET (MSDS)

Issued: Oct 3, 2012

Revised: Oct 3, 2012

File No. 2302-1

1. CHEMICAL PRODUCT & COMPANY IDENTIFICATION

CHEMICAL PRODUCT NAME : DURANEX® 310NF EF2001
NAME OF COMPANY : WinTech Polymer Ltd.
SECTION IN CHARGE : Quality Assurance Dept.
ADDRESS : 2-18-1 Konan, Minato-ku, Tokyo, 108-8280 Japan
TELEPHONE NUMBER : 03-6711-8605
FACSIMILE NUMBER : 03-6711-8616

2. HAZARDS IDENTIFICATION

【GHS CLASSIFICATION】 :

•Physical and Chemical Hazards : Flammable solids : Classification not possible
Self-reactive substances and mixtures : Not applicable
Pyrophoric solids : Not classified
Self-heating substances and mixtures : Not classified
Substances and mixtures, which in contact with water, emit flammable gases : Not classified
Oxidizing solids : Not classified
Corrosive to metal : Not classified

•Health Hazards : Carcinogeneses : No hazard
Specific target organ/systemic toxicity (Repeated exposure) : No hazard

•Environmental Hazards : No hazard

【SYMBOL】 : None

【SIGNAL WORD】 : None

【HAZARD STATEMENT】 : None

【PRECAUTIONARY STATEMENTS】 :

•Prevention : •Wash hands thoroughly after handling.
•Wear protective gloves.

•Response :

•Storage : •Avoid direct sunlight and store in a well-ventilated place.

•Disposal : •Dispose of contents/container in accordance with local & national regulations.

3. COMPOSITION/INFORMATION ON INGREDIENTS

SUBSTANCE/PREPARATION : Preparation

COMMON CHEMICAL NAME : Polybutyleneterephthalate

SYNONYMS : Polybutyleneterephthalate(PBT)

INGREDIENTS AND COMPOSITION : PBT ≥ 60%, Glass fiber 10%, Phosphorus Flame retardant and others ≤ 30%

CHEMICAL FORMULA : $\left[\text{C}_6\text{H}_4\text{CO}(\text{CH}_2)_4\text{CO} \right]_n$

SERIAL No. IN : 7-1039 (base resin)
OFFICIAL GAZETTE : (Law Concerning Examination and Regulation of Manufacture, etc., of
Chemical Substances)
CAS No. : 24968-12-5 (base resin)

4. FIRST-AID MEASURES

INGESTION : Help to vomit as much as possible. If sick feeling continues, and ask a physician for advice.

INHALATION : When a gas generated from the molten polymer, especially fume generated during combustion or heat, has been inhaled, remove fresh air without delay and wait until the victim is recovered. If sick feeling continues, ask a physician for advice.

SKIN CONTACT : Cool the contacted skin with clean water without delay, if a contact with the polymer in a molten form. Do not force to remove the solid resin on the skin. If any burns are observed on the skin, ask a physician for advice.

EYE CONTACT : Cool and rinse the eye with clean water for at least 15 minutes when the eyes had contact with molten polymer. In case of wearing contact lenses, remove the lenses as soon as possible, and ask a physician for advice. When the eye had contact with the polymer in an ordinary solid form, rinse the eye with clean water without delay. If the discomfort persists, ask a physician for advice.

5. FIRE-FIGHTING MEASURES

EXTINGUISHING MEDIA : Water, foam fire-extinguishing agent, powder fire-extinguishing agent, and carbon dioxide gas.

SPECIFIC METHODS : Extinguish the fire with water. A method of extinguishing an ordinary fire may be applied. Do not apply water directly to processing machines.

SPECIFIC HAZARDS : Incomplete combustion leads to generation of toxic gases such as carbon monoxide or tetrahydrofuran, in addition to carbonic acid gas and water.

SPECIAL EQUIPMENT FOR THE PROTECTION OF FIREFIGHTERS : In case the fire gained force, use a gas mask or other protective equipment.

6. ACCIDENTAL LEAKAGE MEASURES

PERSONAL PRECAUTIONS : When pellets were spilled on the road or floor, wipe them off with a broom or cleaner not to cause slipping.

ENVIRONMENTAL PRECAUTION : Handle the spillage in accordance with provisions given in the "Resin pellet spillage preventive manual", in order to prevent intakes by marine animals and birds.

7. HANDLING AND STORAGE

HANDLING : This resin in a pellet form will neither ignite nor explode at room temperatures.

HANDLING 2 : For molding work, effective means for local exhaust are required to discharge gases generated by melt processing.

HANDLING 3 : Avoid inhaling of gases generated in moulding work. Do not directly touch resin of high temperature.

HANDLING 4 : Avoid retaining hot resin in the processing machines for many hours.

HANDLING 5 : This pellets spilled on the floor are likely to cause slipping. Remove such spillage at any times.

HANDLING 6	: Glass fibers are not generally exposed in a single substance under normal processing and handling conditions as they are compounded in pellets. However, the following measures will be necessary to minimize the exposure to glass fibers or dusts containing glass fibers, when pellets or molded parts containing glass fibers are cut, ground or burnt, depending on environmental and operational conditions. <ul style="list-style-type: none"> • Those who are sensitive in skin to glass fiber should wear suitable (protective) clothes to minimize the exposure of their skin. • Wash working clothes apart from other laundry, so that the latter will not cause contamination with glass fibers. • Provide the workshop with partitions to prevent diffusion of glass fiber dusts. • Pay precautions not to rub face, neck or arms with hands. Wash hands and gargle after working without fail. • Keep dust sources totally enclosed. • Provide local air exhausters and implement periodical inspections and adjustments at least once a year. • Reduce cutting and grinding processes to the possible minimum, and devise working procedures to minimize dust generation. • Provide dust-preventive masks, protective glasses and gloves for personal hygiene. • Determine the operational environment at indoor working places and confirm the effects of environmental improvement. Note) Glass fibers are, like road dusts, told to be least hazardous to human bodies, but proper measures are required to avoid useless inhaling.
STORAGE	: Keep the substance away from any fire or heat sources for the sake of safe storage.
RECOMMENDED PACKAGING MATERIALS	: No information.

8. EXPOSURE CONTROL / PERSONAL PROTECTION

CONTROL CONCENTRATION	: None at present
PERMISSIBLE CONCENTRATION	: OSHA PEL/1985 Max. permissible concentration of inactive powder 15mg/m ³ - ditto - (Aspiration) 5 mg/m ³ ACGIH TLV/1992 1993 Exposure limit of the powder TWA 10 mg/m ³
ENGINEERING MEASURE	: When handling dust: Use totally enclosed containers resisting dust explosion. When heat melted in molding: Effective local ventilation must be provided.
PERSONAL PROTECTIVE EQUIPMENT	:
RESPIRATORY PROTECTION	: Wear a dust-proof mask.
EYE PROTECTION	: Wear protective glasses or goggles.
HAND PROTECTION	: Wear heat-resisting gloves against burns, when handling molten polymer.
SKIN & BODY PROTECTION	: Wear long sleeve clothes against burns, when handling molten polymer.

9. PHYSICAL AND CHEMICAL PROPERTIES

APPEARANCE etc.	: Pellet
BOILING POINT	: Not applicable

VAPOUR PRESSURE	: Not applicable
VOLATILITY	: Not applicable
SUBLIMATION	: None
MELTING POINT	: 228°C
DENSITY	: 1.40g/cm ³
SOLUBILITY	: Insoluble in water
FLASH POINT	: 300°C or higher
IGNITION POINT	: 300°C or higher
EXPLOSION PROPERTY	: Not applicable
INFLAMMABILITY	: None
REACTIVITY WITH WATER	: None
OXIDIZABILITY	: None
SELF-REACTIVITY	: None
DUST EXPLOSIVENESS	: Upper explosion limit : Not applicable. Lower explosion limit : 35g/m ³

10. STABILITY AND REACTIVITY

STABILITY AND REACTIVITY	: Stable for normal storage or handling.
--------------------------	--

11. TOXICOLOGICAL INFORMATION

SKIN CORROSIVE PROPERTIES	: No finding.
SENSITIZING & IRRITANT EFFECTS	: Gas generated in drying or melting is irritating eyes and skins.
ACUTE TOXICITY(INCLUDING LD50)	: No finding.
SUBACUTE TOXICITY	: No finding.
CHRONIC TOXICITY	: No finding.
CARCINOGENECITY	: No finding.
MUTAGENECITY(Microorganisms,chromosomal aberration)	: No finding.
REPRODUCTIVE TOXICITY	: No finding.
TERATOGENICITY	: No finding.
OTHERS(Including generation of hazardous gases by reaction with water,for example)	: No finding in this report means that there will be no hazard in general,but no proving data available at the time of reporting.
OTHER CAUTIONS	: With regard to dust,the maximum permissible concentration and limits are fixed by OSHA and ACGIH.

OTHER CAUTIONS : Information on hazards of glass fibers as filler.
2 <Effects on Human Bodies>

(1) Effects on skin

Stimulation to the skin with glass fibers may be caused when glass fibers diameter is larger than $4.5 \sim 5 \mu\text{m}$. They give mechanical stimulation followed by itchiness to the skin, but further continuous exposure reportedly results in extinction of stimulation. It may sometimes leads to irritable dermatitis complicated with urticaria or eczema-like reaction. It is, however reported that such dermatitis is not so serious in general and does not last too long. Therefore, skin stimulation can be prevented by proper use of glass fibers.

(2) Effects on Tumor

Investigations made on glass fibers till today reveal that there is neither increase in mortality of glass fiber production workers due to lung cancer or mesothelioma nor such cases reported.

<Animal Test Report>

It is suggested that carcinogenicity of mineral fibers is dependent on their shapes rather than on their constituents. According to a report on experiments using 17 kinds of artificial mineral fibers in various sizes prepared by Dr.Stanton of National Cancer Institute, in USA, statistical studies on corelations between the diameter and length of fibers and the coincidence of mesothelioma have revealed that mineral fibers having a diameter smaller than $0.25 \mu\text{m}$ and a length larger than $8 \mu\text{m}$ are closely related to the coincidence of cancers. Since these experiments were performed by artificially dosing the subject animals with a large quantity of glass fibers and consequently they are quite different from the actual exposures to human bodies, it is told to be problematic to make a conclusion that mineral fibers are hazardous to human health, basing on the results obtained from these experiments. Upto the present time, there is no result obtainable to demonstrate a mechanism of glass fibers causing lung cancers in spite of experiment by long exposure to glass fibers with high concentration.

12. ECOLOGICAL INFORMATION

BIODEGRADABILITY : No finding.

BIOACCUMULATIO : No finding.
N

FISH TOXICITY : No finding.

13. DISPOSAL CONSIDERATION

WASTE FROM : This is designated as waste plastics among industrial wastes by the
RESIDUES Wastes Disposal Law. Disposal waste pellets through licensed wastes handlers or local autonomous bodies if they are handling wastes disposal.

WASTE FROM : When disposed by incineration,use the well controlled incinerators in
RESIDUES 2 accordance with the Wastes Disposal Law,Air Pollution Control Law and Water Pollution Prevention Law.

14. TRANSPORT CONSIDERATION

UN : Not applicable
CLASSIFICATION
NUMBER

OTHER CAUTIONS : Handle with care so as not to give damages to containers or not to be subjected to wetting.

OTHER CAUTIONS : Secure the containers firmly so as not to cause collapsing.
2

15. REGULATORY INFORMATION

WASTE DISPOSAL : Waste plastics among industrial wastes.
LAW

16. OTHER INFORMATION

**HANDLING OF THE
DETAILS GIVEN
ABOVE** : This MSDS is the English version translated from the Japanese
MSDS which is prepared for domestic use.
Details given above are based on references, information and data
available at this moment, but no warranty can be made on exactness
of these details. They are also prepared on the assumption that the
product will be handled in a normal way. For special handling,
adequate safety and environmental measures should be taken in
respect to its applications. Our products are not specifically intended
for implants for medical and dental applications, and therefore they
are not recommended for such applications.
"No finding" in this report means that there will be no hazard in
general, but no proving data is available at the time of reporting.

**WHERE TO CALL
FOR FURTHER
INFORMATION** : WinTech Polymer Ltd. Quality Assurance Dept.
Tel. No 03-6711-8605

Material Safety Data Sheet (MSDS)

物质安全数据表

SECTION 1. IDENTIFICATION OF THE SUBSTANCE/PREPARATION AND OF THE COMPANY

第一部分 物质/配制品/公司名称

1.1 Identification of the chemical (substance or preparation)

化学品（物质或配制品）名称：**BRASS**

1.2 Use of the chemical

化学品用途：五金机械类加工用

1.3 Company identification

公司信息

Company name 公司名：苏州博联铜业有限公司
Address 地址：江苏省吴江市七都镇建设路 88 号
Postal code 邮编：2152034
Country 国家：中国
Telephone number 电话：0512-63808992
Fax number 传真：0512-63808992

E-Mail (person responsible for MSDS) 责任人邮箱：blty2992@163.com

Date of latest version MSDS 最新版日期：2015-10-15

1.4 Emergency Telephone

应急电话

In case of an emergency, please contact: 紧急情况请联系：0512-63808992

SECTION 2. HAZARDS IDENTIFICATION

第二部分 危险鉴定

按法规的标准不属于有害品类

SECTION 3. COMPOSITION/INFORMATION ON INGREDIENTS

第三部分 成分组成信息

3.1 General Chemical Description

铜金属表面覆镍和锡膜之金属结构

3.2 Base Substances of Preparation

配制品基本成分

<i>components</i> 成分	<i>EC-No.</i>	<i>CAS-No.</i>	<i>Content (% or range)</i> 浓度 (浓度范围)
铜	231-159-6	7440-50-8	57.0%-63.0%
锌	231-111-4	7440-66-6	33.0%-43.0%
铅	--	7439-92-1	0.01%-4.00%

3.3 Declaration of Ingredients according to EC 1907/2006(REACH Regulation) (If necessary)

遵照EC 1907/2006(REACH)成分声明 (如果需要)

<i>Hazardous components</i> 危险成分	<i>EC-No.</i>	<i>CAS-No.</i>	<i>Content (% or range)</i> 浓度 (浓度范围)	<i>Classification</i> 分类
NA 无危害物质				

Please refer to section 16 for an overview of all R-phrases mentioned here.

涉及的所有风险分级 (R-phrases) 请参阅第十六部分。

SECTION 4. FIRST AID MEASURES

第四部分 急救措施

4.1 General information

一般建议

<i>Exposure Route</i> 接触途径	<i>Specific First Aid Measures</i> 具体急救措施
<i>Inhalation</i> 呼吸吸入	热融化后的可能产生重金属熏烟, 吸入熏烟可能导致贫血, 失眠, 体弱等不良状况。
<i>Skin</i> 皮肤接触	热融化的产品可能导致皮肤灼伤(极少发生)。
<i>Eye contact</i> 眼睛接触	极高温融化的熏烟导致眼睛刺痛, 过敏(极少发生)。
<i>Ingestion</i> 食入	导致消化不良和可能导致胃部损伤。

4.2 Advice to doctor

医生注意: 无

SECTION 5. FIRE-FIGHTING MEASURES

第五部分 消防措施

5.1 Suitable fire-fighting equipment

合适的消防设备

	Suitable 适合	Unsuitable 不适合
Fire fighting equipment 消防设备	不易燃烧, 选择适用干粉, 泡沫, 洒水, 二氧化碳灭火器 热的产品喷溅导致灼伤。	无
Protection gear 保护用具	穿著防火衣和佩戴自携式呼吸器	无

5.2 Dangerous decomposition products: 无

5.3 Additional information for firefighters: 无

SECTION 6. ACCIDENTAL RELEASE MEASURES

第六部分 泄露应急处理

6.1 Personal precautions : 无

6.2 Environmental precautions : 产品可回收再用

6.3 Methods for cleaning up/taking up : 产品可回收再用

清除的方法

用惰性物质吸收，做有害废物处理。

SECTION 7. HANDLING AND STORAGE

第七部分 操作处置和储存

7.1 Handling : 无

7.2 Storage

储存环境: 温度-5~40度C, 湿度小于 65%

7.3 Specific use(s)

无

SECTION 8. EXPOSURE CONTROLS / PERSONAL PROTECTION

第八部分 接触控制/个人防护

8.1 Exposure limit values

最大暴露浓度: 外部表面金属高温高湿易氧化, 需按照规格储存。

8.2 Exposure controls

暴露控制: 无相关数据

Environmental exposure controls

环境暴露控制: 无相关数据

SECTION 9. PHYSICAL AND CHEMICAL PROPERTIES

第九部分 理化特性

9.1 General information

常规信息: Appearance 外观: 金黄色的固体

9.2 Important health, safety and environmental information

重要健康、安全和环保信息

Acidity/pH pH值	不适用
Boiling point/boiling range 沸点/沸程	不适用
Flash point 闪点	不适用
Flammability (solid, gas) 易燃性(固体, 气体)	不易燃烧
Explosive properties 爆炸特性	不适用
Oxidising properties 氧化性	不适用
Vapour pressure 蒸汽压力	不适用
Relative density 相对密度	不适用
Solubility 溶解度	不适用
Water solubility 水溶性	不适用
Partition coefficient: n-octanol/water 分配系数: 辛醇/水	不适用
Viscosity 粘度	不适用
Vapour density 蒸汽密度	不适用
Evaporation rate 蒸发率	不适用

9.3 Other information

其它信息: 无

SECTION 10. STABILITY AND REACTIVITY

第十部分 稳定性和反应活性

10.1 Conditions to avoid

应避免的情况: 高温和潮湿

10.2 Materials to avoid

应避免接触的物质: 无

10.3 Hazardous decomposition products: 无相关数据

SECTION 11. TOXICOLOGICAL INFORMATION

第十一部分 毒理学资料

无相关数据

SECTION 12. ECOLOGICAL INFORMATION

第十二部分 生态学资料

12.1 Ecotoxicity

无相关数据

12.2 Mobility

流动性：不适用

12.3 Persistence and degradability

持久性和降解性：不适用

12.4 Bioaccumulative potential

生物累积的潜在可能性：无相关数据

12.5 Results of PBT assessment

PBT评估结果：无相关数据

12.6 Other adverse effects

其它不利影响：无相关数据

SECTION 13. DISPOSAL CONSIDERATIONS

第十三部分 废弃处理

金属材料可回收再使用

SECTION 14. TRANSPORT INFORMATION

第十四部分 运输信息

Classification according to ADR

陆地运输：不是危险品，无相关限制

Classification according to IMDG

海运：不是危险品，无相关限制

Classification according to IATA

航空运输：不是危险品，无相关限制

运输分类可能会因容器的体积和国家或地区的法规而有所不同

SECTION 15. REGULATORY INFORMATION

第十五部分 法规信息

无相关资料

SECTION 16. OTHER INFORMATION

第十六部分 其它信息

无其他的信息

參考文獻	依據我司产品规格书		
製表單位	名稱： 苏州博联铜业有限公司	製表人	张月泉
	地址： 江苏省吴江市七都镇建设路 88 号	製表日期	2015 年 10 月 15 日



A724NA
AD4011

ALLOY High Impact / Natural
ALLOY超韌級 / 本色

SHINITE® ALLOY

		Unit	Test Method	Values
Mechanical properties		機械性質		
Izod Impact(Notched)	衝擊強度	Kg-cm/cm	ASTM D256	80
-20°C	衝擊強度	Kg-cm/cm	ASTM D256	75
-40°C	衝擊強度	Kg-cm/cm	ASTM D256	70
Tensile Strength	拉伸強度	Kg/cm ²	ASTM D638	530
Nominal Tensile Strain at Break	拉伸率	%	ASTM D638	> 50
Flexural Strength	彎曲強度	Kg/cm ²	ASTM D790	780
Flexural Modulus	彎曲模數	Kg/cm ²	ASTM D790	20000
Thermal properties		熱性質		
Heat Deflection Temperature	熱變形溫度		ASTM D648	
66psi		°C		-
264psi		°C		74
Flammability	防火性	-	UL94	HB
Melting Point	熔點	°C	DSC	223
Melt Index	熔融指數	g/10min	ASTM D1238	14
Electrical properties		電氣性質		
Dielectric Strength	介電強度	KV/MM	ASTM D149	38
Dielectric Constant	介電常數	...	ASTM D150	-
Volume Resistivity	體積電阻	Ω-CM	ASTM D257	1E+17
Other properties		其它性質		
Specific Gravity	比重	-	ASTM D792	1.20
Water Absorption	吸水率	%	ASTM D570	0.14
Mold Shrinkage	成形收縮率		ASTM D955	
Flow	流動方向	%		0.4~0.6
Cross Flow	垂直方向	%		0.5~0.7
Injection Molding		成型條件		
INJECTION MACHINE	成型機台	OZ		3
DRYING	乾燥			2 HR ×140 (°C) 4 HR ×120 (°C) 6 HR ×100 (°C)
BARREL TEMPERATURE	成型溫度	°C		
REAR				240-230
MIDDLE				245-235
FRONT				250-240
NOZZLE				255-245
MOLD TEMPERATURE	模溫	°C		60-80
INJECTION PRESSURE	射出壓力	kg/cm ²		600-1000
INJECTION SPEED	射出速度	-		FAST

以上數據僅供參考，實際數據以產品出廠檢驗報告為準
Data listed above is for reference. The actual quality of certain batch is varied within a specific range, as indicated in each COA.

此塑料規格獲得UL防火認證，並經第三公正檢測單位檢驗通過RoHS和SVHC法規，歡迎至新光網站或來信查詢檢測報告
This grade is UL V-0 approved, and comply with RoHS & SVHC regulatio
Feel free to inquire the testing report on www.shinkong.com.tw or mail to service@shinkong.com.tw

EC SAFETY DATA SHEET

1. COMPANY Shinkong Synthetic Fibers Corporation,
Engineering Plastic Division,
8F, 123, Sec. 2, Nanking East Road,
Taipei, Taiwan

PHONE 02-2507-1251, 03-493-2131

FAX 02-2507-7594, 03-491-5763

1. COMMERCIAL PRODUCT NAME : SHINITE A724

Chemical Characterization : Blends of polycarbonate(CAS#25971-63-5) and Polybutylene Terephthalate (PBT)

CAS# 30965-26-5

Physical State : Solid

Odor and Form : Pellet with slight odor

2. Hazardous Decomposition Products :

Processing fumes evolved at recommended processing conditions contain trace levels of carbon monoxide, carbon dioxide ,aromatic and aliphatic hydrocarbons and may also contain trace levels of THF (tetrahydrofuran).

4. First Aide :

If molten polymer contacts the skin or eyes, cool rapidly with cold water. DO NOT use solvent for removal.

DO NOT attempt to remove the polymer from the skin!

Obtain IMMEDIATE medical attention.

5. Measures in Case of Accidents and Fires

After Spillage/Leakage/Gas Leakage :

Sweep up and dispose in proper containers to prevent slipping hazards.

Fire Extinguishing Media :

Suitable - water spray and foam. Water is the best.

Not recommended - carbon dioxide and dry chemicals.

Fire Fighting : Approved pressure demand breathing apparatus and protective clothing should be used for all fires.

6. Industrial Hygiene :

A continuous supply of fresh air to the workplace together with removal of processing fumes through exhaust systems is recommended.

7. Storage and Handling

Storage :

Store in a cool and dry place. Keep containers tightly closed to prevent moisture absorption and contamination.

Handling :

Follow recommendations in processing guide. Prevent contact with skin and eyes.

Provide adequate ventilation.

8. Protective Measures

Respiratory protection - dust mask

Eye protection - safety glasses

Hand protection - thermal protective gloves should be worn around molten plastic

9. Physical Data and Safety Data

Melting Point (°C) : -(because of PC/PBT alloy is Alloy type)

Density @ 25°C : 1.10~1.30 g/cm³ ASTM D 1505

Vapor Pressure : Not applicable

Viscosity : Not applicable

Solubility in Water : Insoluble

PH value : Not applicable

Flash Point : Not applicable

Ignition Temperature (°C) : 450°C, estimated

Explosion : Not sensitive to impact and static discharge.

Thermal Decomposition : None under 400°C

Stability : Stable under recommended conditions of storage and handling.

Reactivity : Not reactive under recommended conditions of storage, handling, processing and use.

Conditions to Avoid : Do not exceed temperature recommended. Purgings should be collected in small shapes to allow for rapid cooling.

10. Protection Against Fire and Explosion :

Large, molten masses of plastic may ignite spontaneously in air.

Water quenching of plastic fires is recommended.

11. Information on Toxicity TOXIC : N/A

Product not considered primary eye and skin irritant.

12. Information on Ecological Effects

We recommend this material be disposed of by properly scrubbed incineration or recycling. Not expected to present any significant ecological problems.

13. Disposal :

Product is not a RCRA hazardous waste. Recycling is encouraged. Dispose of using good manufacturing practices under local regulations for your area.

14. Transport

GGVSEE/IMDG Code : UN No. : None

ICAO/IATA-DGR : Not Regulated GGVE/GGVS :

RID/ADR : ADNR :

DOT Hazard Class : Not Regulated

Proper Shipping Name : Not Regulated

Identification Number : Not Listed

TDGA : Not Listed

15. Regulations

TSCA Status : This product complies with Chemical Substance Inventory requirements of the US EPA Toxic Substances Control Act (TSCA).

WHMIS Classification : Not a controlled product.

Commercial Product Name : Shinite A724

16. Further Information

SHINITE is a registered trademark of the SHINKONG SYNTHETIC FIBERS CO..

QMFZ2 Component - Plastics	Wednesday, September 14, 2005	E107536
----------------------------	-------------------------------	---------

SHINKONG SYNTHETIC FIBERS CORP
 223 YEN PING RD SEC 3 PIN CHENG TAOYUAN HSIEN 324 TW

Material Designation: [A724](#)

Product Description: Polybutylene Terephthalate/Polycarbonate (PBT/PC), furnished as pellets.

Color	Min. Thick. (mm)	Flame Class	HWI	HAI	RTI Elec	RTI Imp	RTI Str	IEC GWIT	IEC GWFI
NC	0.8	HB	4	1	75	75	75	-	-
	1.6	HB	4	1	75	75	75	-	-
	3.2	HB	2	1	75	75	75	-	-

CTI: -	IEC CTI (V): -	HVTR: 2	D495: -	IEC Ball Pressure (°C): -
--------	----------------	---------	---------	---------------------------

Dielectric Strength (kV/mm): 38	Volume Resistivity (10 ⁹ ohm-cm): 17	Dimensional Stability(%): -
ISO Tensile Strength (MPa): -	ISO Flexural Strength (MPa): -	ISO Heat Deflection (°C): -
ISO Tensile Impact (kJ/m ²): -	ISO Izod Impact (kJ/m ²): -	ISO Charpy Impact (kJ/m ²): -

Report Date: 4/6/1992	Underwriters Laboratories Inc®
-----------------------	--------------------------------

UL94 small-scale test data does not pertain to building materials, furnishings and related contents. UL 94 small-scale test data is intended solely for determining the flammability of plastic materials used in components and parts of end-product devices and appliances, where the acceptability of the combination is determined by ULI.

POM (共聚甲醛)

夺钢™

DURACON®

M90-44

(标准品级)

宝理塑料

Polyplastics

目录

1. M90-44的一般性质

客户注意事项

- 本资料所记载的物性值是按各种规格及实验方法规定的条件下制得的实验片的代表性测试值。
- 有关适当的操作规程，请根据使用目的参考相应材料的[技术资料]。
- 本资料是根据本公司积累的经验及实验数据作成的，本文所示数据对在不同的条件下使用的制品不一定能完全适用。
因此其内容并非能保证完全适用于客户的使用条件，引用或借用时请客户作最终判断。
- 有关本公司材料的安全使用，请参考与所用材料、品级相对应的制品安全数据表 [MSDS]。
- 有关本资料所介绍的应用例、使用例等技术及数据、使用寿命、可能性等请客户自作考虑。此外，本公司材料并没有考虑到在医疗和齿科方面的应用（用作移植组织片），故不推荐用在此方面。
- 本资料是根据现阶段搜集到的资料、信息、数据而作成的，如有新的见解时，有可能不加预告而作更改，敬请注意。
- 对本公司制品的说明材料，或者是这里所说的注意事项等，如有任何不明白的地方，敬请与本公司联系商谈。

*[DURACON®]（夺钢）是宝理塑料株式会社在日本及其他国家的注册商标。

1. M90-44的一般物性

表1-1 一般物性(ISO)

项 目	单 位	试验方法	标准
			M90-44
			标准
密度	g/cm ³	ISO 1183	1.41
拉伸强度	MPa	ISO 527-1,2	62
断裂应变	%	ISO 527-1,2	35 ^{*1}
拉伸弹性模量	MPa	ISO 527-1,2	2700
弯曲强度	MPa	ISO 178	87
弯曲模量	MPa	ISO 178	2500
简支梁冲击强度(有缺口)	kJ/m ²	ISO 179/1eA	6
负荷变形温度(1.8MPa)	°C	ISO 75-1,2	95
线性热膨胀系数((23×55° C)流动方向)	x10 ⁻⁵ /°C	ISO 11359-2	12
线性热膨胀系数((23×55° C)垂直方向)	x10 ⁻⁵ /°C	ISO 11359-2	12
绝缘破坏强度(3mmt)	kV/mm	IEC 60243-1	19
体积电阻率	Ω · cm	IEC 60093	1×10 ¹⁴
表面电阻率	Ω	IEC 60093	1×10 ¹⁶
阻燃性		UL94	HB

以上数值为材料的代表性测试值、并非该规格材料的最低值。

*1)断裂公称应变

*2)有关UL (Underwriters Laboratories Inc.) 的认定值、请参照UL发行的黄卡 (File No.E45034)。

*3)本品级受以日本国外汇管理及外国贸易法为依据的出口贸易管理条例表中的第1条第16项的制约。

表1-2 一般物性(ASTM)

项 目	单 位	试验方法	标准
			M90-44
			标准
比重		ASTM D792	1.41
拉伸强度	MPa	ASTM D638	60
拉伸率	%	ASTM D638	60
弯曲强度	MPa	ASTM D790	90
弯曲模量	MPa	ASTM D790	2580
悬臂梁冲击强度(有缺口)	J/m	ASTM D256	63
悬臂梁冲击强度(无缺口)	J/m	ASTM D256	760
负荷变形温度(1.82MPa)	°C	ASTM D648	110
线性热膨胀系数(常温、流动方向)	$\times 10^{-5}/^{\circ}\text{C}$	ASTM D696	10
线性热膨胀系数(常温、垂直方向)	$\times 10^{-5}/^{\circ}\text{C}$	ASTM D696	10
绝缘破坏强度(短时间法:2mmt)	MV/m	ASTM D149	24
体积电阻率(3mmt)	$\Omega \cdot \text{cm}$	ASTM D257	1×10^{14}
表面电阻率(3mmt)	Ω	ASTM D257	1×10^{16}
阻燃性		UL94	HB

以上数值为材料的代表性测试值、并非该规格材料的最低值。

*1)有关UL (Underwriters Laboratories Inc.) 的认定值、请参照UL发行的黄卡 (File No.E45034) 。

*2)本品级受以日本国外汇管理及外国贸易法为依据的出口贸易管理条例表中的第1条第16项的制约。

Polyplastics

宝理塑料株式会社

日本东京都港区港南2丁目18番1号
JR品川East Building (邮编:108-8280)
Phone:81-3-6711-8600 Fax:81-3-6711-8606

Affiliates

Polyplastics Asia Pacific Sdn. Bnd. (Kuala Lumpur)
Polyplastics Asia Pacific Singapore Pte. Ltd. (Singapore)
Polyplastics Marketing (T) Ltd. (Bangkok)

宝理塑料(中国)有限公司(香港)
宝理工程塑料贸易(上海)有限公司(上海)
宝理塑料贸易(上海)有限公司(上海)
台湾宝理塑料有限公司(台北)
宝泰菱工程塑料(南通)有限公司(南通)

MATERIAL SAFETY DATA SHEET (MSDS)

Issued: Dec 27 , 2001

Revised: May 7 , 2002

File No. 1001

1. CHEMICAL PRODUCT & COMPANY IDENTIFICATION

CHEMICAL PRODUCT NAME : DURACON M90-44
NAME OF COMPANY : Polyplastics Co.,Ltd.
SECTION IN CHARGE : Quality Assurance Dept.
ADDRESS : 3-2-5 Kasumigaseki, Chiyoda-ku, Tokyo
TELEPHONE NUMBER : 03-3593-2280
FACSIMILE NUMBER : 03-3593-2189

2. COMPOSITION/INFORMATION ON INGREDIENTS

SUBSTANCE/PREPARATION : Substance
RATION
COMMON CHEMICAL NAME : Polyoxymethylene
SYNONYMS : Polyacetal(POM)
INGREDIENTS AND COMPOSITION : POM \geq 98%, Stabilizers etc. \leq 2%
CHEMICAL FORMULA : $\left[\text{CH}_2 - \text{O} \right]_p / \left[\text{CH}_2 \text{CH}_2 \text{O} \right]_q$
SERIAL No IN OFFICIAL GAZETTE : 7-129 (base resin)
(Law Concerning Examination and Regulation of Manufacture, etc., of Chemical Substances)
CAS No : 24969-26-4 (base resin)
INGREDIENTS CONTRIBUTING TO THE HAZARD : Formaldehyde

3. HAZARDS IDENTIFICATION

MOST IMPORTANT HAZARDS : Incomplete combustion leads to generation of toxic gases such as carbon monoxide, in addition to carbonic acid gas and water.
Decomposition of polymer also leads to generation of formaldehyde.
HUMAN HEALTH EFFECTS : Not applicable
ENVIRONMENTAL EFFECTS : Not applicable
PHYSICAL AND CHEMICAL HAZARDS : It is inflammable substance and combustible if an igniting source is existent. Neither dangerous reaction, fire nor explosion can be caused under normal conditions.
THE CLASSIFICATION : Not applicable

4. FIRST-AID MEASURES

INGESTION : Help to vomit as much as possible. If sick feeling continues, ask a physician for advice.
INHALATION : When a gas generated from the molten polymer has been inhaled, remove fresh air without delay and wait until the victim is recovered. If sick feeling continues, ask a physician for advice.

- SKIN CONTACT : Cool the contacted skin with clean water without delay,if a contact with the polymer In a molten form. Do not force to remove the solid resin on the skin. If any burns are observed on the skin,ask a physician for advice.
- EYE CONTACT : Cool and rinse the eye with clean water for at least 15 minutes when the eyes had contact with molten polymer. In case of wearing contact lenses,remove the lenses as soon as possible,and ask a physician for advice. When the eye had contact with the polymer in an ordinary solid form,rinse the eye with clean water without delay. If the discomfort persists,ask a physician for advice.
-

5. FIRE-FIGHTING MEASURES

- EXTINGUISHING MEDIA : Water,form fire-extinguishing agent,powder fire-extinguishing agent,and carbon dioxide gas.
- SPECIFIC METHODS : Extinguish the fire with water. A method of extinguishing an ordinary fire may be applied. Do not apply water directly to processing machines.
- SPECIFIC HAZARDS : Incomplete combustion leads to generation of toxic gases such as carbon monoxide or formaldehyde,in addition to carbonic acid gas and water.
- SPECIAL EQUIPMENT FOR THE PROTECTION OF FIREFIGHTERS : In case the fire gained force,use a gas mask or other protective equipment.
-

6. ACCIDENTAL LEAKAGE MEASURES

- PERSONAL PRECAUTIONS : When pellets were spilled on the road or floor,wipe them off with a besom or cleaner not to cause slipping.
- ENVIRONMENTAL PRECAUTION : Handle the spillage in accordance with provisions given in the "Resin pellet spillage preventive manual",in order to prevent intakes by marine animals and birds.
-

7. HANDLING AND STORAGE

- HANDLING : Polyacetal resin in a pellet form will neither ignite nor explode at room temperatures, but it falls under the inflammables designated by the Fire Service Law. Keep it away from the igniting sources, as it quickly gains force once it is ignited.
- HANDLING 2 : Polyacetal resin in a powdered form is likely to cause dust explosion and is therefore designated in the Guideline for Hazard of Dust Explosion in U.S.Bureau of Mines. Effective earthing means or use of inert gas like N₂ are required for dust handling equipment to eliminate static electricity.
- HANDLING 3 : Polyacetal pellets spilled on the floor are likely to cause slipping. Remove such spillage at any times.
- HANDLING 4 : For molding work,effective means for local exhaust are required to discharge gases generated by melt processing.
- HANDLING 5 : Avoid inhaling of gases generated in moulding work. Do not directly touch resin of high temperature.
- HANDLING 6 : Avoid retaining hot resin in the processing machines for many hours.
- HANDLING 7 : Avoid mixed extrusion with strong acid,oxidizing agents and PVC.
- STORAGE : Keep the substance away from any fire or heat sources for the sake of safe storage.
- STORAGE 2 : This polymer is a synthetic resin designated as an inflammable substance by the Fire Service Law and should be handled in accordance with municipal rules and regulations (concerning fire-fighting equipment, indoor storage, for instance).

RECOMMENDED : No information.
PACKAGING
MATERIALS

8. EXPOSURE CONTROL / PERSONAL PROTECTION

CONTROL : None at present
CONCENTRATION

PERMISSIBLE : OSHA PEL/1985
CONCENTRATION Max. permissible concentration of inactive powder 15mg/m³
- ditto - (Aspiration) 5mg/m³
ACGIH TLV/1992 1993
Exposure limit of the powder TWA 10 mg/m³
(Reference) Human exposure to formaldehyde
- Ministry of Health & Welfare/2002
Guideline value 0.08 ppm
OSHA Parameter/1992
TWA 0.75 ppm
STEL 2 ppm
ACGIH TLV/1992 1993
TWA 0.3 ppm

ENGINEERING : When handling dust: Use totally enclosed containers resisting dust
MEASURE explosion.
When heat melted in molding: Effective local ventilation must be provided.

PERSONAL :
PROTECTIVE
EQUIPMENT

RESPIRATORY : Wear a dust-proof mask.
PROTECTION

EYE PROTECTION : Wear protective glasses or goggles.

HAND PROTECTION : Wear heat-resisting gloves against burns, when handling molten
polymer.

SKIN & BODY : Wear long sleeve clothes against burns, when handling molten polymer.
PROTECTION

9. PHYSICAL AND CHEMICAL PROPERTIES

APPEARANCE etc. : Pellet

BOILING POINT : Not applicable

VAPOUR : Not applicable
PRESSURE

VOLATILITY : Not applicable

SUBLIMATION : None

MELTING POINT : 165°C

DENSITY : 1.41

SOLUBILITY : Insoluble in water

FLASH POINT : 320°C or higher

IGNITION POINT : 400°C or higher

EXPLOSION : Not applicable
PROPERTY

INFLAMMABILITY : Inflammable(Designated as inflammable resin by the Fire Service Law)

REACTIVITY WITH : None
WATER

OXIDIZABILITY : None
SELF-REACTIVITY : None
DUST : Upper explosion limit : Not applicable.
EXPLOSIVENESS : Lower explosion limit : 35g/m³

10. STABILITY AND REACTIVITY

STABILITY AND REACTIVITY : Stable for normal storage or handling.
CONDITIONS TO AVOID : Avoid contacts with strong acid, oxidizing agent or PVC under hot melt conditions.
HAZARDOUS DECOMPOSITION PRODUCTS : Formaldehyde will be generated when heated (for drying or melting) or burnt.

11. TOXICOLOGICAL INFORMATION

SKIN CORROSIVE PROPERTIES : No finding.
SENSITIZING & IRRITANT EFFECTS : Gas generated in drying or melting is irritating eyes and skins.
ACUTE TOXICITY (INCLUDING LD50) : No finding.
SUBACUTE TOXICITY : No finding.
CHRONIC TOXICITY : No finding.
CARCINOGENICITY : No finding.
MUTAGENICITY (Microorganisms, chromosomal aberration) : No finding.
REPRODUCTIVE TOXICITY : No finding.
TERATOGENICITY : No finding.
OTHERS (Including generation of hazardous gases by reaction with water, for example) : No finding in this report means that there will be no hazard in general, but no proving data available at the time of reporting.
OTHER CAUTIONS : With regard to dust, the maximum permissible concentration and limits are fixed by OSHA and ACGIH.
OTHER CAUTIONS : Formaldehyde will be generated when heated (for drying or melting) or burnt.

12. ECOLOGICAL INFORMATION

BIODEGRADABILITY : No finding.
BIOACCUMULATION : No finding.
FISH TOXICITY : No finding.

13. DISPOSAL CONSIDERATION

WASTE FROM RESIDUES : This is designated as waste plastics among industrial wastes by the Wastes Disposal Law. Disposal waste Duracon through licensed waste handlers or local autonomous bodies if they are handling waste disposal.

WASTE FROM RESIDUES 2 : When disposed by incineration, use the well controlled incinerators in accordance with the Wastes Disposal Law, Air Pollution Control Law and Water Pollution Prevention Law.

14. TRANSPORT CONSIDERATION

UN CLASSIFICATION NUMBER : Not applicable

OTHER CAUTIONS : Handle with care so as not to give damages to containers or not to be subjected to wetting.

OTHER CAUTIONS 2 : Secure the containers firmly so as not to cause collapsing.

15. REGULATORY INFORMATION

FIRE SERVICE LAW : Inflammable synthetic resin
Designated quantity: More than 20m³ for the foamed product.
More than 3,000 kg for other types.

WASTE DISPOSAL LAW : Waste plastics among industrial wastes.

OTHERS : Formaldehyde is designated as Class 3 substance by the Industrial Safety and Health Law (Regulations concerning hazards caused by specific chemicals) and designated as deleterious substance by the Poisons and Deleterious Substance Control Law. Recommended usage, criteria, and limit values are provided by Japan Industrial Safety and Health Society, OSHA and ACGIH.

16. OTHER INFORMATION

HANDLING OF THE DETAILS GIVEN ABOVE : This MSDS is the English version translated from the Japanese MSDS which is prepared for domestic use.
Details given above are based on references, information and data available at this moment, but no warranty can be made on exactness of these details. They are also prepared on the assumption that the product will be handled in a normal way. For special handling, adequate safety and environmental measures should be taken in respect to its applications. Our products are not specifically intended for implants for medical and dental applications, and therefore they are not recommended for such applications.
"No finding" in this report means that there will be no hazard in general, but no proving data is available at the time of reporting.

WHERE TO CALL FOR FURTHER INFORMATION : Polyplastics Co., Ltd. Quality Assurance Dept.
Tel. No 03-3593-2280



長春人造樹脂廠股份有限公司

台北市 10477 松江路三零一號七樓

CHANG CHUN PLASTICS CO.,LTD.

NO.301 SONGKIANG ROAD, 7FL., TAIPEI, TAIWAN, R.O.C.

TEL: 886-2-25038131

FAX:886-2-25033378

材質證明

MATERIAL FORMULATION CONFIDENTIAL REPORT

材質名稱 Type of Material : TPEE(Thermoplastic Polyether-ester Elastomer)
熱塑性聚醚酯彈性體

規格 Grade : TPEE 1140, 1155, 1163, 1172

說明 Description :

TPEE 1140, 1155, 1163, 1172 熱塑性聚醚酯彈性體包含 TPEE 純樹脂及添加劑。TPEE 1140, 1155, 1163, 1172 完全符合 RoHS 指令的規定。The raw material of TPEE 1140, 1155, 1163, 1172 contains TPEE pure resin and a few of additives. We certify that our TPEE1140, 1155, 1163, 1172 can be according with RoHS regulation.

TPEE 1140, 1155, 1163, 1172 成分表

Chemical Composition of TPEE 1140, 1155, 1163, 1172

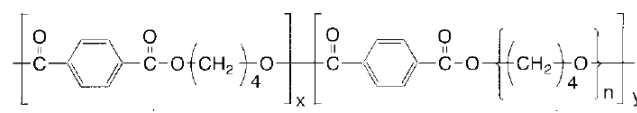
規格 Grade TPEE 1140, 1155, 1163, 1172			
組成 Chemical Composition	Molecular formula	CAS Number	含量(%) Content (%)
1 TPEE樹脂 TPEE resin	(1) Chemical formula $(C_{10}H_{10}O_4 \cdot C_4H_{10}O_2 \cdot (C_4H_8O)_nH_2O)_x$ (2) Chemical Structure 	9078-71-1	>99.5%
2 添加劑 Additives	NA	NA	0.2-0.5%

MATERIAL SUPPLIER

Company: CHANG CHUN PLASTICS CO., LTD KAOHSIUNG FACTORY

Signature: Ching-Neng Tseng / Chief Manager / Technical Section

Address: No.14 KUNG-YEH 1ST ROAD. JEN-WU INDUSTRIES DISTRICT

KAOHSIUNG, TAIWAN, ROC.

Date: July 22, 2008



物质安全资料表

一、物品与厂商资料

物品名称：热塑性聚酯弹性体
其它名称：TPEE 1130, 1140, 1148, 1155, 1163, 1172
建议用途及限制使用：建议使用汽车零件，天线，电线电缆，运动器材等
制造商或供货商名称、地址及电话： 长春人造树脂厂股份有限公司/台北市松江路301号7楼 TEL: 886-2-2500-1800； FAX: 886-2-2501-8018 http://www.ccp.com.tw/
紧急联络电话/传真电话：+ 886-7-3711301

二、危害辨识资料

物品危害分类：无
标示内容：无
象征符号：无
警示语：无
危害警告讯息：过度高温产生烟雾及气体可能造成鼻子、喉咙及呼吸道的不适。
危害防范措施：无
其它危害：无

三、成分辨识资料

纯物质
中文名称：热塑性聚酯弹性体
同义名称：共聚酯弹性体
化学文摘社登记号码(CAS No.): 9078-71-1
危害物质成分：无

四、急救措施

不同暴露途径之急救方法： <ul style="list-style-type: none">· 吸入：当吸入加热所产生之气体时：<ul style="list-style-type: none">- 尽速移至通风良好之处- 身体以半竖立姿势休息- 松开衣物- 保持温暖· 皮肤接触：若高温的液体产物溅到皮肤，应立即冲冷水来冷却，并应送医治疗。注意：勿从伤口处移走溶解的材料· 眼睛接触：若被高温的液体产物溅到眼睛，立即送医并以大量的冷水冲洗。· 食入：无毒性物质危险，此材料不具生物活性
最重要症状及危害效应：无
对急救人员之防护：无
对医师之提示：如果碰触到熔体，请以大量冷水冲洗，并寻求医疗协助。

五、灭火措施

适用灭火剂：水、干粉、泡沫、二氧化碳
灭火时可能遭遇之特殊危害：无
特殊灭火程序：依A级火灾处理，并避免吸入粉尘
消防人员之特殊防护设备：穿着个人防护装备

六、泄漏处理方法

个人应注意事项：处理时应穿着个人防护装
环境注意事项：此物质无毒性及生态危害问题
清理方法：清扫放入垃圾桶内，可回收使用

七、安全处置与储存方法

处置: 需足够的通风和排气喷口, 喷管。灰尘和油烟处理时排气通风须有效处理

储存: 应存放于干燥及通风良好之处

八、暴露预防措施

工程控制: 无			
控制参数			
八小时日时量平均 容许浓度 TWA	短时间时量平均 容许浓度 STEL	最高容许 浓度 CEILING	生物指标
10mg/m ³	无规范	无规范	无规范
个人防护设备: · 呼吸防护: 防粉尘用防护面罩 · 手部防护: 隔热手套 · 眼睛防护: 安全护目眼镜 · 皮肤及身体防护: 穿合适防护手套和衣服, 以隔绝和皮肤最少的接触			
卫生措施: 应在所有的工作地点设置足够的洗涤设施, 使用品温的肥皂或洗手液, 溶剂不可用作洗手液。吸烟, 进食和饮水在工作区和储存区应予以禁止。			

九、物理及化学性质

外观: 白色固体	气味: 无臭
嗅觉阈值: 无	熔点: 150-220°C
Ph值: 无	沸点/沸点范围: 无
易燃性(固体,气体): 无	闪火点: >335 °C
分解温度: >300°C	测试方法: ASTM D93
自燃温度: >420°C	爆炸界限: 无
蒸气压: 无	蒸气密度: 无
度: 1.0 -1.27 kg/l(25°C)	溶解度: 无
辛醇 / 水分配系数(log Kow): 无	挥发速率: 无

十、安定性及反应性

安定性: 在正常使用和存放情形下安定

特殊状况下可能之危害反应: 勿长时间加热至300°C以上, 以避免热降解

应避免之状况: 加热至300°C以上

应避免之物质: 强碱, 强碱, 强氧化剂

危害分解物: 一氧化碳, 二氧化碳, 酸, 醇, 四氢呋喃

十一、毒性资料

暴露途径(吸入, 进食, 皮肤或眼睛接触): 无
症状: 无
急毒性: 无
慢毒性或长期毒性: 无

十二、生态资料

生态毒性: 无
持久性及降解性: 持久性
生物蓄积性: 无

土壤中之流动性：无
其它不良效应：如果眼睛和皮肤有刺激反应，可能影响中枢神经系统

十三、废弃处置方法

废弃处置方法：1. 回收再利用 2. 视为工业废弃物, 焚化处理

十四、运送数据

联合国编号：无规范
联合国运输名称：无规范
运输危害分类：无规范
包装类别：太空包, 纸袋
海洋污染物（是 / 否）否
特殊运送方法及注意事项：非危险运送物品, 保持货品远离潮湿.

十五、法规资料

适用法规：无规范

十六、其它数据

参考文献		
制窗体位	名称：长春人造树脂厂股份有限公司高雄厂	
	地址/电话：高雄市仁武區工业一路14号/(07)3711301	
制表人	职称：副工程师	姓名：胡益嘉
制表日期	2008/9/24	修改日期：2011/2/11
备注	Email: yjhu@ccp.com.tw	

物质安全资料表

MATERIAL SAFETY DATA SHEET

一、物品与厂商资料 Article and supplier information:

物品名称: 环保热缩套管 H Article: Heat shrinkable tube (WOER)
规格型号: Spec: black plastics w/ white printing
供货商名称: 昆山沃尔康电子有限公司 Supplier: KUNSHAN VOLKAN ELECTRONICS CO. LTD

二、成分资料 Composition and information on ingredients:(G 管) 混合物 Admixture

化学性质: 环境物质 (CHEMICAL PROPERTIES: ENVIRONMENT MATERIALS)			
英文名称 (English name)	中文名 Chinese name	含量 Content	测试方法 Test method
Cadmium	镉 (Cd)	≤100ppm	EN1122: 2001
Lead	铅 (Pb)	≤1000ppm	EPA3050B
Chromium (VI)	铬 (Cr) VI	≤1000ppm	EPA7196A、EPA3060A
Mercury	汞 (Hg)	≤1000ppm	EPA3052
Polybrominated Biphenyls (PBBS)	多溴联苯	≤1000ppm	EPA3540C EPA3550C
Polybrominated Diphenylethers (PBDES) except DecaBDE	多溴联苯醚(不 含十溴联苯醚)	≤1000ppm	EPA3540C EPA3550C

三、辨别资料 DISCERN INFORMATION:

最重要的 危害项目 KEY HAZARD ITEM	健康危害效应: 点燃后在短时间内会熄灭, 有少量烟雾产生, 对人体呼吸道产生轻微伤害。 Health hazard note: Be fired for a moment and will be flameout, it will produce a little smoke, the smoke will hazard breath a little.
	环境影响: 危害空气。Environment hazard note: If be fired and pollute the air.
	物理性及化学性危害: 常态是管状, 在 90-125℃ 预热收缩。Physics and chemistry characteristic: it normal is pipe and will shrink at 90-125℃, that perhaps is harmful.
	特殊危害: 如果火烤、烟熏, 烟雾会冲击眼睛、呼吸系统, 对人体产生伤害。 Specific hazard: if be fired or sootiness, it will produce smoke and smoke hurt eyes breath.
主要症状: 眼睛流泪, 喷嚏, 咳嗽, 在呼吸新鲜空气会减轻相应症状。 Main symptom: lachrymation, sneeze, cough. It will be good after breathing fresh air.	
物品燃烧危险: 必须在点燃时会短时间燃烧。 Fireproofing characteristic: It can flame for a moment after leaving fire.	

四、急救措施 FIRST—AID MEASURES:

不同暴露途径之急救方法: First-aid measures: 吸入: 在正常操作下没有吸入的危险。Normal it is no harmful for breath. If be fired, and breath the smoke 皮肤接触: 正常接触时对皮肤无损伤。由于此管易划伤, 建议操作时戴手套。 Skin touch: Normal it is no harmful for skin

眼睛接触: 无影响 Normal it is no harmful for eyes. If be fired , the smoke hurt eyes a little, leave the smoke and eyes will come to comfort.
食入: 不能食用 Can't be eat.
最重要及危害效应: 吸入燃烧烟雾, 冲击呼吸系统。Key symptom: Be fired ,the smoke choke the breath.
对急救人员之防护: 配戴呼吸防护装置。First aid defend: Get on gas mask
对医师之提示: 对呼吸系统严重症者, 应不断吸入新鲜空气来减轻症状。 Doctor suggest: If breath a lot of smoke ,must breath more fresh air , it can help you to reduce the symptom.

五、FIRE-FIGHTING MEASURES:

适用灭火剂: 不能长时间燃烧, 使用粉末灭火器。Fire-fighting material medical: Dust farina powder
灭火时可能遭遇之特殊危害: 燃烧可产生少量烟雾, 冲击人体呼吸系统。 During fire-fighting, special hazard: Be fired ,produce a little smoke , and it can choke the breath
特殊灭火程序: 无。Special fire-fighting program: No special program
消防人员之特殊防护设备: 正常消防设备。Fire-fighter special dependence: Normal fire-fighting device

六、GIVEAWAY TRANSACT METHOD:

个人应注意事项: 无 Person notice: No
环境注意事项: 无 Environment notice: No
清理方法: 无 Cleaning method: No special method

七、安全处理与储存方法 SAFETY AND DEPOSIT METHOD

处置: 常温下用纸箱包装, 不要放置在太阳光下直射。 Treatment: At normal temperature ,paper box package, no sun straight shine
储存: 常温下用纸箱包装好放置在凉荫处。 Deposit: At normal temperature paper box package, no sun straight shine

八、物理及化学性质 PHYSICAL AND CHEMICAL PROPERTIES:

物质状态: 软质套管。State: Soft pipe	形状: 套管状 Shape: Pipe
颜色: 黑色及彩色。Color: Manifold color	气味: 无味 Smell: No
分解温度: 125℃ 预热收缩, 不会分解。 Decompose temperature: 125 °C shrink, but don' t decompose	闪点: 阻燃 Flash point: Fire-resistant
自然温度: 常温 Normal temperature	爆炸界限: 无 Explode rate: No

九、稳定性及反应性 STABILITY AND REACYIVITY:

稳定性: 不能分解。Stability: No decompose
特殊状况下可能之危害反应: 有火的话, 此种产品会短时间燃烧, 产生烟雾。Special condition, perhaps hazard: If has fire, the production can be fired for a moment and produce a little smoke
应避免之状况: 高温放置会收缩。 Please avoid the condition: At heat temperature condition the production will shrink
应避免之物质: 火种 Please avoid the condition: Fire
危害分解物: 烟雾。Hazard decompose material: Smoke

十、毒性资料 TOXICOLOGICAL INFORMATION:

急毒性: 无 Rapid virulence: No
局部效应: 无 Part effect: No
致敏感性: 无 Cause hypersusceptibility : No
慢毒性或长期毒性: 无 Slowly or long-term virulence: No
特殊效应: 无 Special effect: No

十一、生态效应 ECOLOGICAL INFORMATION:

可能之环境影响/环境流: 该产品不会在自然界分解, 对动植物及水生物不会产生危害。

Perhaps environment effect: The production can't decompose at nature condition, so it can't hazard the animal and plant.

十二、处置注意事项 DISPOSAL CONSIDERATIONS:

废弃处置方法: 这些物品将统一收集给废品收购站, 作相应环保处理。

Trash disposal: Collect and treat for the environment.

十三、运送资料 TRANSPORTATION INFORMATION:

国际运送规定: 无 World wild transportation rule: No

联合国编号: 无 U.N. code: No

国内运送规定: 无 Transportation in china rule: No

特殊运送方法及注意事项: 避免挤压变形, 利器损伤。Special transportation method and notice: Avoid extrusion distortion, edge tool hurt

十四、法规资料 REGULATORY INFORMATION:

适用法规: UL224 Comply rule or law: UL224

十五、其它资料 OTHER INFORMATION:

参考文献: SGS 检测报告 Reference : SGS Test Report

(以上内容如有歧义以中文为准 If the Chinese and English content have some different things, the Chinese content is right)

昆山沃尔康电子有限公司
套管品质部
2010年12月12日



NOTICE OF AUTHORIZATION TO APPLY THE UL MARK

2007-09-18

Mr. Shaodun He
SHENZHEN WOER HEAT-SHRINKABLE MATERIAL CO LTD
Xinwei Industrial Park, Woer Mansion
Nanshan District, Xili
Shenzhen, Guangdong 518052
China

E-mail: sfshhd@163.com

Reference: File E203950 Project 07SC04243 P.O. Number HE, SHAODUN
USR/CNR - Evaluation of Currently Recognized Heat Shrinkable Flexible Cross-linked
Product: Polyolefin Tubing Cat. No. RSFR-H, rated 125C, 600V, VW-1, in all colors except clear, in 0.35
mm to 75.0 mm recovered ID, with modified compound.

Dear Mr. He,

Any information and documentation involving UL Mark services are provided on behalf of Underwriters Laboratories Inc. (UL) or any authorized licensee of UL.

UL's investigation of your product has been completed under the above project number and the subject product was determined to comply with the applicable requirements.

This letter temporarily supplements the UL Follow-Up Services Procedure and serves as authorization to apply the UL Recognized Marking and/or Recognized Component Mark only at the factory under UL's Follow-Up Service Program to the subject product, which is constructed as described below:

Identical to the subject model, which was submitted to UL for this investigation. The UL Records covering the product will be in the Follow-Up Services Procedure, File E203950, Volume 2. See attachment – 5 pages.

This authorization applies only to the address on this letter.

This authorization is effective from the date of this Notice and only for products at the indicated manufacturing locations. Records in the Follow-Up Services Procedure covering the product are now being prepared and will be sent to the indicated manufacturing locations in the near future. Please note that Follow-Up Services Procedures are sent to the manufacturers only unless the Applicant specifically requests this document.

Products that bear the UL Mark shall be identical to those that were evaluated by UL and found to comply with UL's requirements. If changes in construction are discovered, appropriate action will be taken for products not in conformance with UL's requirements and continued use of the UL Mark may be withdrawn.

Sincerely,

Audrey Woo
Project Engineer
Department: 3015TSCL
Tel: 408-754-6507
Fax: 408-689-6507
E-mail: audrey.woo@us.ul.com

Reviewed by:

JaneAnn P Matulich
Lead Engineering Associate
Department: 3015TSCL
E-mail: janeann.p.matulich@us.ul.com



DESCRIPTION

PRODUCT COVERED:

USR, CNR: Component - Extruded Electrical Tubing, Heat-Shrinkable Polyolefin Tubing, are Recognized with the following ratings:

Cat. No.	Colors	Recovered ID, mm	Temp. Rating, Deg. C	Voltage Rating, V	Flame Rating
RSFR-x	Black	1.0 - 4.0	125	600	VW-1
RSFR-x	White	0.5 - 25.0	125	600	VW-1
WKZM-x-yz	White	0.5 - 25.0	125	600	All Tubing
RSFR-H	All except Clear	0.35 - 75.0	125	600	VW-1

Note: for RSFR-x only, Black color tubing - x represents expanded ID of 2 mm - 8 mm. For White color tubing - x represents expanded ID of 1 mm - 50 mm.

Note: for WKZM-x-yz only, - x represents expanded ID of 1 mm - 50 mm and - yz represents any alpha and/or numeric combination for internal Client code.

USR: United States Standard Recognized.

CNR: Canadian National Standard Recognized.

GENERAL:

The tubing contained in this Report is constructed in accordance with the Bi-National Standard for Extruded Insulating Tubing, UL 224, Fifth Edition, and with the Canadian Standard for Insulating Tubing, CSA 22.2, No. 198.1, Second Edition.

MARKING:

Full Recognized company name, or File Number "E203950", catalog number, voltage rating, temperature rating in degrees C, inside diameter (before and after recovery) and date of manufacture shall be marked on tags attached to both ends of the tubing, on the shipping spool label, or on the smallest unit container.

The tag markings shall include the Recognized Component Mark for Canada, , in order to be considered UL Canadian Certified.

OPTIONAL MARKING:

- * Cat. Nos. **RSFR-H** and RSFR-x may be marked "VW-1".
- Cat. No. WKZM-x-yz: None

CONSTRUCTION DETAILS:

The tubing shall conform to the appropriate wall thickness and dimension table in UL 224 and to the following:

Cat. No.	Recovered ID, mm	Color	Material	Composition Formulation @
RSFR-x	1.0 - 4.0	Black	Polyolefin	Beijing Chemical EVA (14-2) 100%
RSFR-x	0.5 - 25.0	White	Polyolefin	Beijing Chemical EVA (14-2)100%
WKZM-x-yz	0.5 - 25.0#	White	Polyolefin	Beijing Chemical EVA (14-2) 50% with Huiyuan Chemical Co., Ltd. KY-405 50%
RSFR-H	0.35 - 75.0	All except Clear	Polyolefin	See Table I

@ - The tubing formula consists only of the materials stated in the table. No other materials are added such as plasticizers, anti-oxygen agents, etc., unless specified in the formula above.

Note: for RSFR-x only, Black color tubing - x represents expanded ID of 2 mm - 8 mm. For White color tubing - x represents expanded ID of 1 mm - 50 mm.

Note: for WKZM-x-yz only, - x represents expanded ID of 1 mm - 50 mm and - yz represents any alpha and/or numeric combination for internal Client code.

- the minimum recovered wall thickness is limited to 0.70 mm for the minimum expanded inner diameter size of 1.0 to 16.0 mm.

Maximum Expansion Ratio:

Cat. No. RSFR-x may be expanded up to a maximum of 155% of its original extruded diameter.

Cat. No. WKZM-x-yz may be expanded up to a maximum of 176% of its original extruded diameter.

Cat. No. RSFR-H may be expanded up to a maximum of **335%** of its original extruded diameter.

DESCRIPTION

PRODUCT COVERED:

USR, CNR: Component - Extruded Electrical Tubing, Heat-Shrinkable Polyolefin Tubing, are Recognized with the following ratings:

Cat. No.	Colors	Recovered ID, mm	Temp. Rating, Deg. C	Voltage Rating, V	Flame Rating
RSFR-x	Black	1.0 - 4.0	125	600	VW-1
RSFR-x	White	0.5 - 25.0	125	600	VW-1
WKZM-x-yz	White	0.5 - 25.0	125	600	All Tubing
RSFR-H	All except Clear	0.35 - 75.0	125	600	VW-1

Note: for RSFR-x only, Black color tubing - x represents expanded ID of 2 mm - 8 mm. For White color tubing - x represents expanded ID of 1 mm - 50 mm.

Note: for WKZM-x-yz only, - x represents expanded ID of 1 mm - 50 mm and - yz represents any alpha and/or numeric combination for internal Client code.

USR: United States Standard Recognized.

CNR: Canadian National Standard Recognized.

GENERAL:

The tubing contained in this Report is constructed in accordance with the Bi-National Standard for Extruded Insulating Tubing, UL 224, Fifth Edition, and with the Canadian Standard for Insulating Tubing, CSA 22.2, No. 198.1, Second Edition.

MARKING:

Full Recognized company name, or File Number "E203950", catalog number, voltage rating, temperature rating in degrees C, inside diameter (before and after recovery) and date of manufacture shall be marked on tags attached to both ends of the tubing, on the shipping spool label, or on the smallest unit container.

The tag markings shall include the Recognized Component Mark for Canada, , in order to be considered UL Canadian Certified.

OPTIONAL MARKING:

- * Cat. Nos. **RSFR-H** and RSFR-x may be marked "VW-1".
- Cat. No. WKZM-x-yz: None

CONSTRUCTION DETAILS:

The tubing shall conform to the appropriate wall thickness and dimension table in UL 224 and to the following:

Cat. No.	Recovered ID, mm	Color	Material	Composition Formulation @
RSFR-x	1.0 - 4.0	Black	Polyolefin	Beijing Chemical EVA (14-2) 100%
RSFR-x	0.5 - 25.0	White	Polyolefin	Beijing Chemical EVA (14-2)100%
WKZM-x-yz	0.5 - 25.0#	White	Polyolefin	Beijing Chemical EVA (14-2) 50% with Huiyuan ChemicalCo., Ltd. KY-405 50%
RSFR-H	0.35 - 75.0	All except Clear	Polyolefin	See Table I

@ - The tubing formula consists only of the materials stated in the table. No other materials are added such as plasticizers, anti-oxygen agents, etc., unless specified in the formula above.

Note: for RSFR-x only, Black color tubing - x represents expanded ID of 2 mm - 8 mm. For White color tubing - x represents expanded ID of 1 mm - 50 mm.

Note: for WKZM-x-yz only, - x represents expanded ID of 1 mm - 50 mm and - yz represents any alpha and/or numeric combination for internal Client code.

- the minimum recovered wall thickness is limited to 0.70 mm for the minimum expanded inner diameter size of 1.0 to 16.0 mm.

Maximum Expansion Ratio:

Cat. No. RSFR-x may be expanded up to a maximum of 155% of its original extruded diameter.

Cat. No. WKZM-x-yz may be expanded up to a maximum of 176% of its original extruded diameter.

Cat. No. RSFR-H may be expanded up to a maximum of **335%** of its original extruded diameter.