

LITE

承認書

SPECIFICATION FOR APPROVAL

客戶名稱(CUSTOMER):

智易科技股份有限公司

品名(DESCRIPTION):

RF ANTENNA ASSEMBLY
DIPOLE, BLACK+1.13 CABLE GRAY+IPEX

客戶料號(PART NO):

料號(PART NO):

503021-0013-0BC

送樣日期(DATE):

2020.07.31

承認號碼(APPROVED NO):

Liteconn Co., Ltd		Customer Approval	
Prepare	Approval	Check	Approval

堅詠股份有限公司

Liteconn Co., Ltd

Taipei:
Liteconn Co., Ltd
24158新北市三重區中興北街188巷19號

NO.19 Lane 188, Jhongsing N., St.,
Sanchong Dist, New Taipei City 24158

TEL:886-2-2995-0485

FAX:886-2-2995-7395

網址: <http://www.liteconn.com.cn>

ShenZhen:
LiteTek Technology CO., LTD
中國深圳市寶安區松崗街道紅星西坊大田洋工業園D區
D Avenue, Da Tian Yang Industrial
Area, Hong Xing Xi Fang, Song Gang
Town, Bao'an District Shenzhen
518105, China
TEL:86-755-2962-6909~17
FAX:86-755-2962-6919~20

SuZhou:
LiteTek Technology CO., LTD
中國蘇州市吳中區角直鎮機場路39號
(甫澄路口)
NO 39, Airport Road, Luzhi
Town, Wuzhone District, Suzhou, China
TEL:86-0512-6602-7901~3
FAX:86-0512-6602-7910

Antenna Type Dipole

120300087500J

Specifications	
Standard	IEEE802.11n and 802.11 a/b/g/ac
Frequency range	2.4 to 2.49GHz , 4.9 to 5.9 GHz
Peak gain	1.74 dBi @ 2.4 GHz
	1.68 dBi @ 5 GHz

Liteconn Co.,Ltd.

APPROVAL INDEX

1 封面	-----	pages	1
2 Antenna Type & Specifications	-----	pages	2
3 目錄	-----	pages	3
4 產品圖及包規	-----	pages	4~5
5 測報	-----	pages	6~12
6 線材資料	-----	pages	13~17
7 端子資料	-----	pages	18~32
8 銅管資料	-----	pages	33~38
9 套管資料	-----	pages	39~46
10 塑件資料	-----	pages	47~62

REV.	FILE No.	DRAWN BY	DATE
X0	TWRFGA2007009	Eva_long	2020.07.23

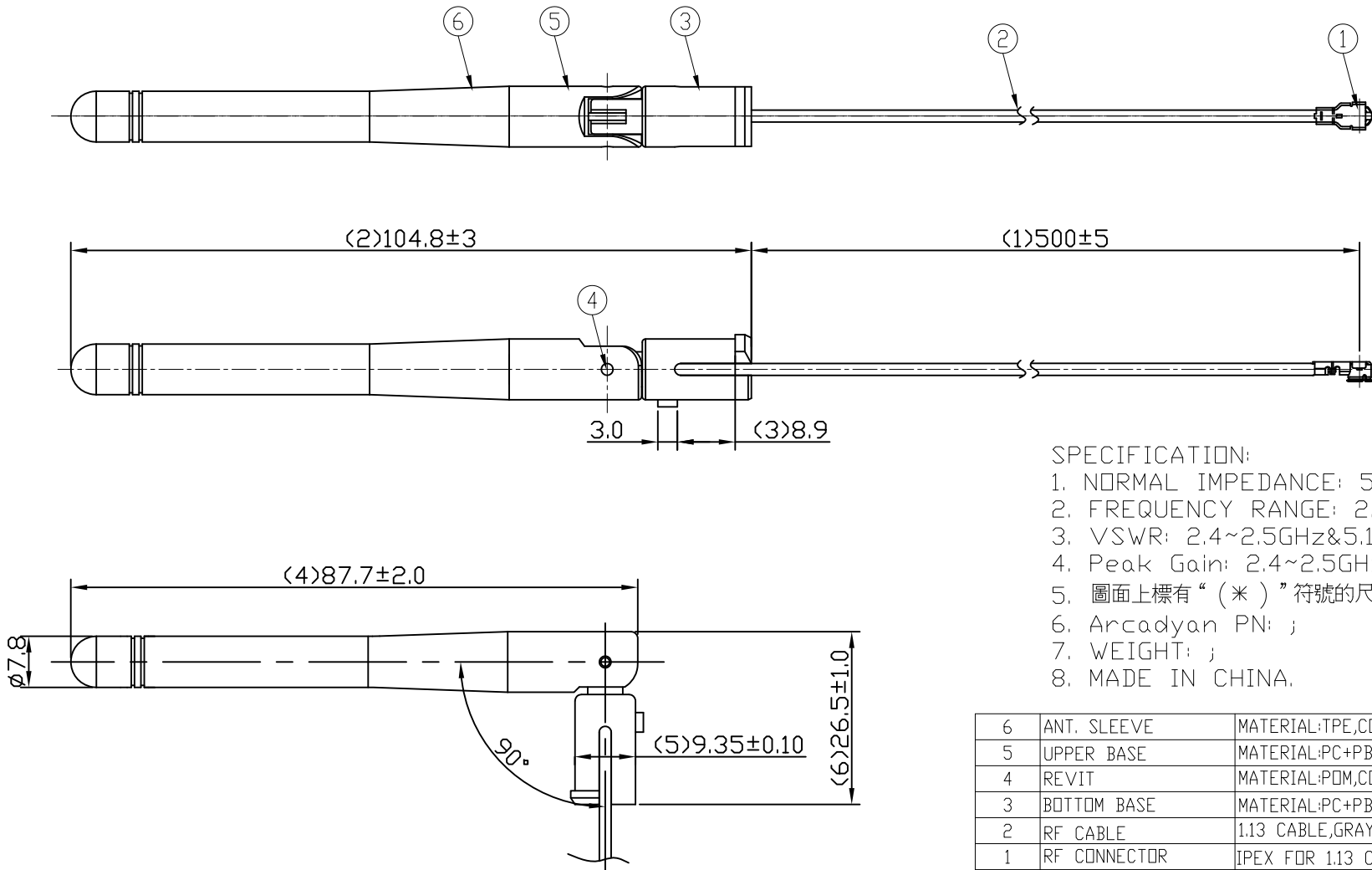

SPECIFICATION:

1. NORMAL IMPEDANCE: 50Ω;
2. FREQUENCY RANGE: 2.4~2.5GHz&5.15~5.85GHz;
3. VSWR: 2.4~2.5GHz&5.15~5.85GHz≤2.0;
4. Peak Gain: 2.4~2.5GHz≥2dBi,5.15~5.85GHz≥2dBi;
5. 圖面上標有“(*)”符號的尺寸為重點管控尺寸,
6. Arcadyan PN: ;
7. WEIGHT: ;
8. MADE IN CHINA.







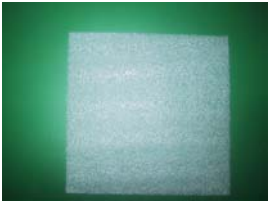

6	ANT. SLEEVE	MATERIAL:TPE,COLOR:BLACK	1	N/A
5	UPPER BASE	MATERIAL:PC+PBT,COLOR:BLACK	1	N/A
4	REVIT	MATERIAL:PDM,COLOR:BLACK	2	N/A
3	BOTTOM BASE	MATERIAL:PC+PBT,COLOR:BLACK	1	N/A
2	RF CABLE	1.13 CABLE,GRAY	1	N/A
1	RF CONNECTOR	IPEX FOR 1.13 CABLE	1	N/A
ITEM	PART NAME	DESCRIPTION	Q'TY	REMARK

DWG TYPE: CUSTOMER DRAWING		LITE Liteconn Co., Ltd.	
GENERAL TOLERANCE: UNLESS OTHERWISE SPECIFIED		TITLE: RF ANTENNA ASSEMBLY DIPOLE BLACK+1.13 CABLE GRAY+IPEX	
X.X ±0.35	X.X° ±3°	APPD:	DWG No.: 503021-0013-0BC
X.XX ±0.25	X.XX° ±2°	CHECK:	
X.XXX ±0.15	X.XXX° ±1°	DRAW: Eva_long	DATE: 2020.07.23
		SCALE: 1:1	UNIT: mm
		PAGE: 1/1	

COMPIANCE WITH THE REQUIREMENT: ✓RoHS; □ HF; □ SONY SS-00259; □ OTHER.
*NO USING RESTRICTED AND BANNED SUBSTANCE

蘇州利慶電子有限公司

包裝作業規範

LITE	標題	包裝作業規範： 純板端天線		備注： ECN NO:EN1101014
文件編號	AAA-CAR-0041	版次	A1	作業說明：
<p>包裝作業示意圖：</p> <div style="display: flex; justify-content: space-around; align-items: flex-start;"> <div style="text-align: center;">  圖1: 成品 </div> <div style="text-align: center;">  圖2: 珍珠棉 </div> <div style="text-align: center;">  圖3: 橡皮筋 </div> </div> <div style="display: flex; justify-content: space-around; align-items: flex-start; margin-top: 10px;"> <div style="text-align: center;">  圖4: 25PCS一扎 </div> <div style="text-align: center;">  圖5: 膠袋 </div> <div style="text-align: center;">  圖6: 裝入膠袋 </div> </div> <div style="display: flex; justify-content: space-around; align-items: flex-start; margin-top: 10px;"> <div style="text-align: center;">  圖7: 封口機封口 </div> <div style="text-align: center;">  圖8: 裝入紙箱 </div> <div style="text-align: center;">  圖9: 每紙箱1000PCS </div> </div>				<ol style="list-style-type: none"> 1. 將檢驗好的成品每25PCS用氣泡棉裹住,再用橡皮筋扎好,如圖1.2.3.4所示. 2. 將25PCS一扎的成品放入膠袋里面,再在每一膠袋中放入一包干燥劑,然後用封口機封好膠袋口,在PE袋上貼上產品料號標籤,如圖5.6.7所示. 3. 將一平板放入紙箱底部,四個角落加上护角,將封好的每一袋成品放入紙箱里面,如圖8所示. 4. 紙箱一層放10袋成品,共250PCS,每紙箱放4層,共1000PCS. 5. 每裝一層放一平板,一箱放5PCS平板,用膠紙封好,貼上相應的標籤.標籤上注明雙方的料號,如圖所示. 6. 再裝上一外箱,并封裝好,打好包裝帶.

核准:

審核:

制定:

測試報告

TEST REPORT

CUSTOMER : 智易

CUSTOMER NO. : _____

FILE NO : _____

DESCRIPTION : 2.4GHz & 5GHz Antenna

LITE P/N : _____

DATE : 2020/08/03

堅詠股份有限公司

ADD : NO. 19, LANE 188, CHUNG—HSIN N. ST.

SANCHUAN, TAIPEI HSIEN, TAIWAN R.O.C

TEL : (886-2) 2995-0485

FAX : (886-2) 2995-7395

[http : //www.liteconn.com](http://www.liteconn.com)

Test time : 2020/08/03

Company : 智易

Model :

Project : 2.4G & 5G ANTENNA

Photo :

場型量測示意圖

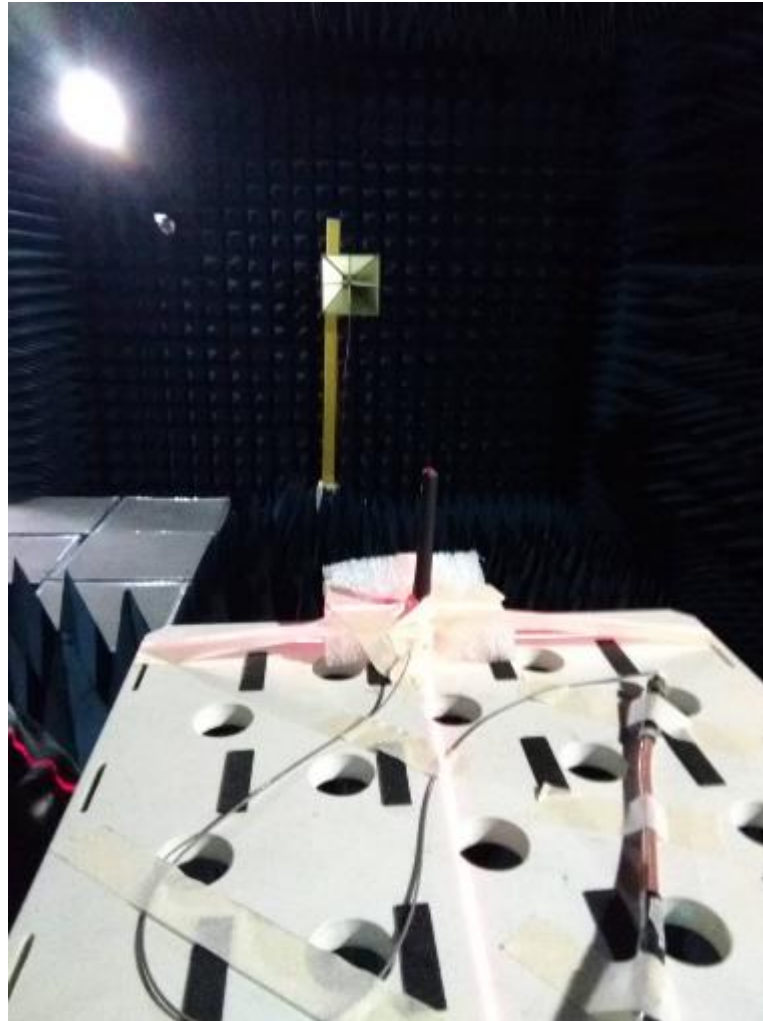
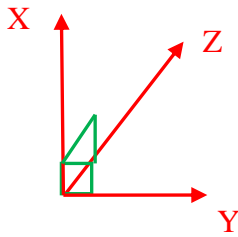



堅詠股份有限公司

Liteconn Co., Ltd.

TEL:+886-2-2995-0485 FAX:+886-2-2995-7395 <http://www.liteconn.com>

CONNECTOR & RF ANTENNA

Test time : 2020/08/03

Company : 智易

Model :

Project : 2.4G & 5G ANTENNA

Photo :

網儀量測示意圖





堅詠股份有限公司

Liteconn Co., Ltd.

TEL:+886-2-2995-0485 FAX:+886-2-2995-7395 http://www.liteconn.com

CONNECTOR & RF ANTENNA

Test time : 2020/08/03

Company : 智易

Model :

Project : 2.4G & 5G ANTENNA

Photo :

ANTENNA 1

Return Loss & VSWR & Smith

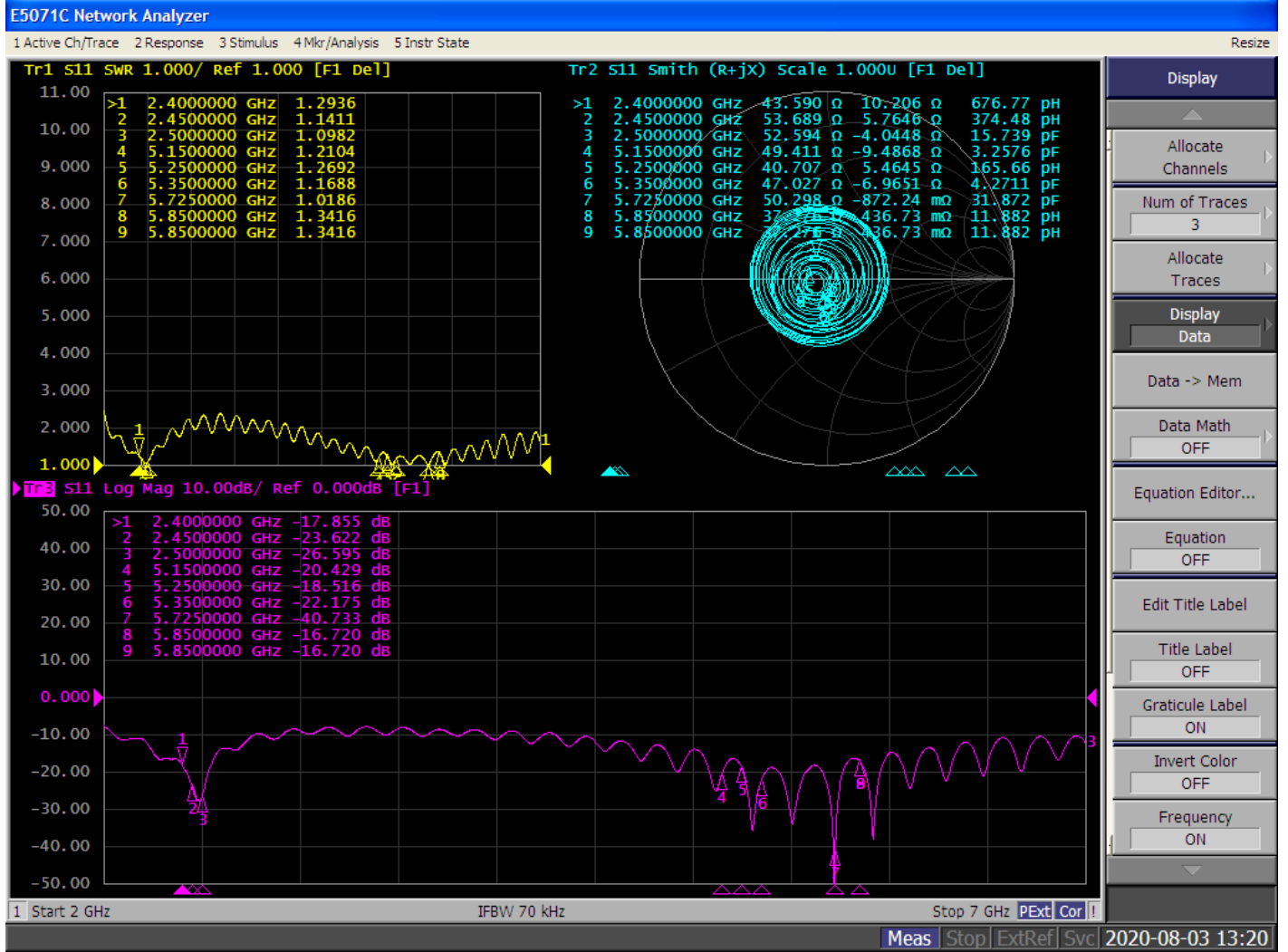

Test time : 2020/08/03

Company : 智易

Model :

Project : 2.4G & 5G ANTENNA

Photo :

ANTENNA 1
3D Radiation Pattern

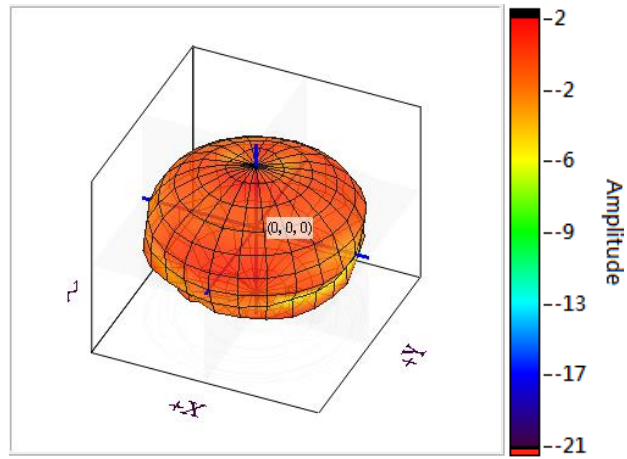

2400 MHz

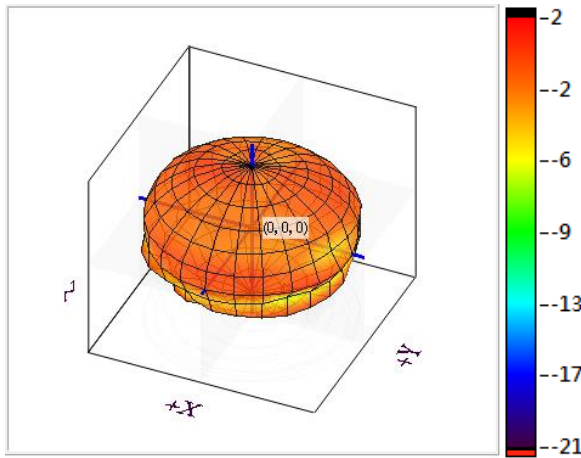

2450 MHz

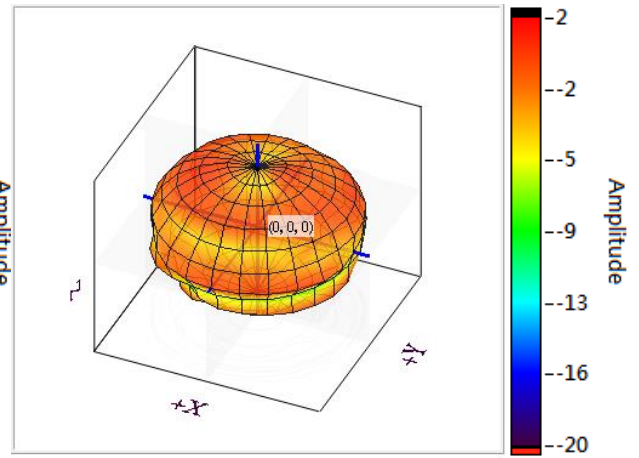

2500 MHz

3D Antenna Gain

Frequency (MHz)	Peak Gain (dBi)	Efficiency (%)
2400	1.59	48.38
2450	1.66	49.76
2500	1.74	50.54

Test time : 2020/08/03

Company : 智易

Model :

Project : 2.4G & 5G ANTENNA

Photo :

ANTENNA 1
3D Radiation Pattern

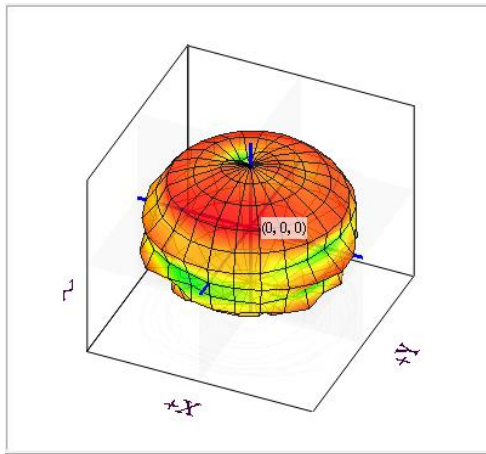

5150 MHz

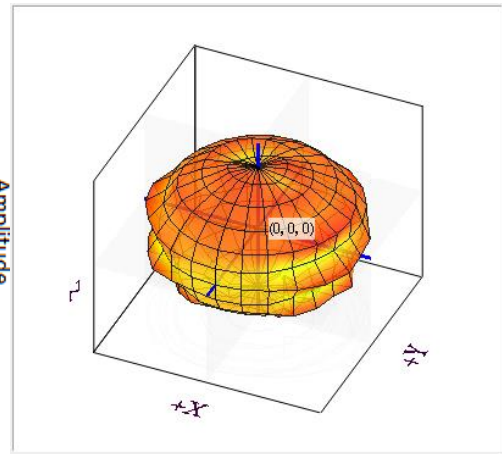

5250 MHz

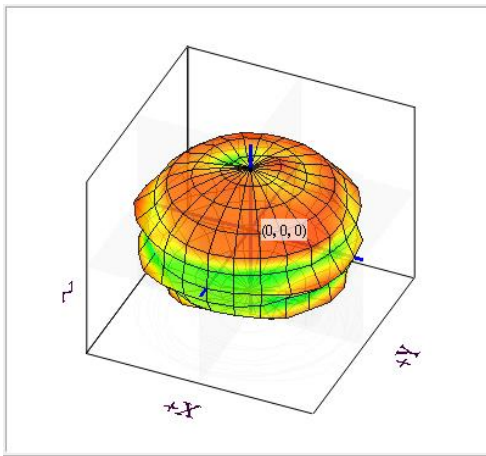

5350 MHz

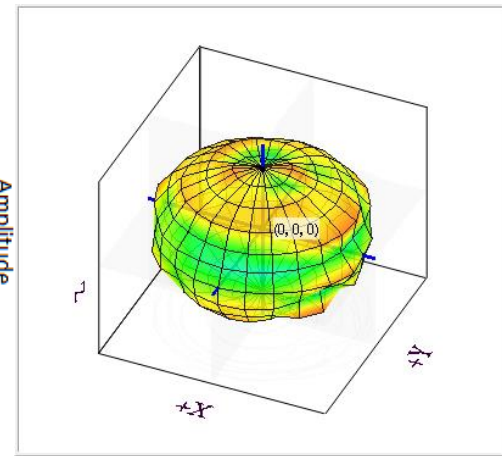

5725 MHz

Test time : 2020/08/03

Company : 智易

Model :

Project : 2.4G & 5G ANTENNA

Photo :

ANTENNA 1
3D Radiation Pattern

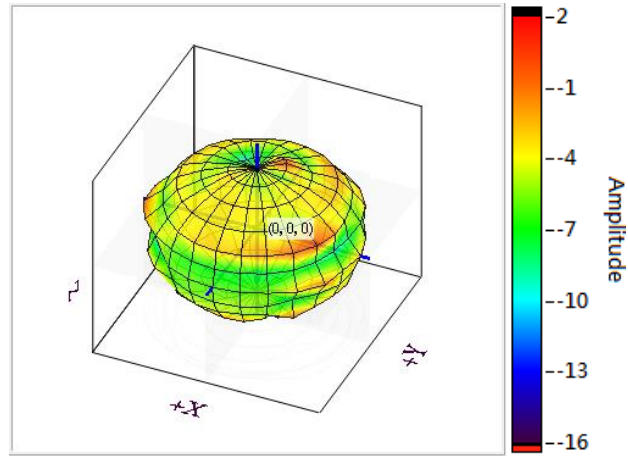

5850 MHz

3D Antenna Gain

Frequency (MHz)	Peak Gain (dBi)	Efficiency (%)
5150	1.34	40.21
5250	1.45	44.05
5350	1.29	38.58
5725	1.27	36.36
5850	1.68	49.77

型号 Type	RF-1.13/50	料号 P/N	ZX113XX	
结构图 Structure drawing				
结构特性 Structure characteristics				
结构 Structure	项目 Item	标准值 Standard value		
①内导体 Inner conductor	材料 Material	镀锡铜线 Tinned copper wire		
	组成:总根数/单根外径(mm) Makeup total / O.D. of every wire(mm)	7/0.08		
	(绞台)标称外径(mm) (Intertwist)NOM.O.D.(mm)	0.24±0.05		
②绝缘层 Insulation	材料 Material	聚全氟乙丙烯 FEP		
	颜色 Color	透明 Clarity		
	标称外径(mm) NOM.O.D.(mm)	0.68±0.05		
③外导体 Outer conductor	材料 Material	镀锡铜线 Tinned copper wire		
	组成:总根数/单根外径(mm) Makeup total / O.D. of every wire(mm)	16*4/0.05		
	标称外径(mm) NOM.O.D.(mm)	0.91±0.05		
	覆盖率(%) Coverage ratio(%)	90±5		
④护套层 Jacket	材料 Material	聚全氟乙丙烯 FEP		
	颜色 Color	灰色 Gray/黑 Black/白 White		
	标称外径(mm) NOM.O.D.(mm)	1.13±0.05		
电性能特性 Electrical characteristics				
项目 Item	标准值 Standard value	项目 Item	频率 Frequency	标准值 Standard value 单位 Unit:dB/m
电容(pF/m) Capacitance(pF/m)	98	衰减 Attenuation	1GHz	≤2.2
速率(%) Velocity(%)	70		2GHz	≤3.1
阻抗(Ω) Impedance(Ω)	50±2		3GHz	≤3.9
驻波比 Standing wave ratio	≤2.0@0~6GHz		4GHz	≤5.0
最大工作电压(V) Max.operating voltage(V)	1000		5GHz	≤5.9
最大工作频率(GHz) Max.operating frequency(GHz)	6		6GHz	≤6.1
可靠性 Dependability				
项目 Item	单位 Unit	标准值 Standard value		
最小弯曲半径(一次) Min.bending radius static	mm	4		
最小弯曲半径(重复) Min.bending radius repeated	mm	—		
工作温度范围 Operating temperature	℃	-55~+200		
包装 Packing				
项目 Item	单位 Unit	标准值 Standard value		
包装方式 Packing mode	/	纸盘 Papery plate		
每盘长度 The length of each plate	m	1000		
每盘接头数 Each connector plate number	/	≤4		
每段最短长度 The shortest length of each root	m	≥10		
使用提示 Use tips				
存储环境 Storage environment	温度: 30℃以下; 湿度: 20%~65%			
最佳保存周期 The best save cycle	2个月; 2个月以上作业性下降, 如上锡效果变差, 但电性能不受影响。夏季高温高湿环境开剥后需尽快流转			
加工温度 Processing temperature	260℃的极限情况下, 可短时间承受; 300℃以上分子通常带有的等端基会分解; 400℃以上发生显著的热分解			
铁氟龙收缩 Teflon Shrink	固有材料特性。绝缘: 0.2mm以下; 护套: 0.3mm以下			
护套窜动 Jacket traverse	加工长度(护套残留长度)低于5cm易发生			
其他 Other				
特殊加工工艺, 请与供方协商后使用				



物质安全数据表(MSDS)

一、物品名称与厂商资料

物品名称	氟塑料电线电缆
物品编号	RF0.81,RF1.13,RF1.37,RG145,RG178,RG316等
供货商名称	苏州市相城区正旭电线电缆有限公司
联系地址	江苏省苏州市相城区阳澄湖镇岸山开发区
紧急联络电话和传真	TEL: 0512-65429886 FAX: 0512-65420768

二、成分辨识资料

	物质名称	分子式	CAS NO	成分含量%
1	铜	Cu	7440-50-8	20~35%
2	锡	Sn	7440-31-5	5~10%
3	PTFE	(C2F4) _n	9002-84-0	20~35%
4	FEP	(C3F6·C2F4) _x	25067-11-2	25~35%
5	色母	-	-	0.5%
6	其它	-	-	2%

三、危害辨识数据:

危害与效应	健康危害效应: 燃烧不产生酸性气体,对人体无害
	环境影响: 无
	物理性及化学性危害: 无
	特殊危害: 无
主要症状: 无	
危害物质分类: 本产品为固态,自然状态下无毒	

四、急救措施:

不同暴露途径之急救方法:	吸入: 吸入溢出的气体, 如有不适, 立即就医
	皮肤接触: 无
	眼睛接触: 无
	食入: 如有不适, 立即就医
最重要症状及危害效应: 无	
对急救人员之防护: 无	
对医师之提示: 告知医师患者接触方式	

五、灭火措施:

适用灭火剂	水、二氧化碳、泡沫
灭火时可能遭遇之特殊危害	无
特殊灭火程序	移除可燃物
消防人员之特殊防护设备	无

六、泄漏处理方法

个人注意事项	本品为固体,不会产生泄露,该项不适用
环境注意事项	本品为固体,不会产生泄露,该项不适用
清理方法	本品为固体,不会产生泄露,该项不适用

七、安全处置与储存方法

处置	操作时小心烫伤
储存	储存于通风良好处,避免阳光直射,避免腐蚀性液体和气体接触

八、暴露预防措施

工程控制: 无
控制参数: 无
个人防护设备: 口罩, 手套 • 呼吸防护: 口罩 • 手部防护: 手套 • 眼睛防护: 无 • 皮肤及身体防护: 无
卫生措施: 保持环境清洁

九、物理及化学性质

物质状态: 固体	形状: 线状
颜色: 客户需求	气味: 无
分解温度: >250℃	沸点: 无
PH值: 中性	爆炸界限: 无

十、安定性及反应性

安定性: 常温下极安定且具化学惰性。
特殊状况下可能之危害反应: 无
应避免之状况: 无
应避免之物质: 无
危害分解物: 无

十一、毒性资料

急毒性：无
局部效应：无
致敏感性：无
慢毒性或长期毒性：无
特殊效应：无

十二、生态资料

可能之环境影响： 此项产品无法被生物分解，但可经适当之方式予以回收再利用。
--

十三、废弃处置方法

废弃处置方法： 需遵守现行中央、省及地方政府之相关法规。

十四、运送资料

国际运送规定：此物质无危险性。
联合国编号：无
国内运送规定：无
特殊运送方法及注意事项：无

十五、法规资料

适用法规：无

十六、其他资料

参考文献	无
表单位	名称：苏州市相城区正旭电线电缆有限公司
	地址：江苏省苏州市相城区阳澄湖镇岸山开发区
	电话：0512-65429886
制表人	赵正刚
制表日期	2015-7-1



**INDUSTRY FILE REVIEW
SUPPLEMENTAL ANNOUNCEMENT LETTER**

UL COMPLIANCE COORDINATOR
SUZHOU XIANGCHENG ZHENGXU WIRES AND CABLES CO LTD
TIANDUOLI ROAD 1.ANSHAN DEVELOPMENT ZONE
YANGCHENGHU TOWN
XIANGCHENG DISTRICT
SUZHOU
CHINA

Our Reference: File E365708

Subject: Industry File Review – Status of Products with Respect to New Requirements in the Standard for Safety for Appliance Wiring Material, UL758 Review ID# 758-2014-013

On June 17, 2016, UL announced an Industry File Review for the Subject Number and Effective Date noted below. New requirements have been developed that may be applicable to your product(s).

SUBJECT NUMBER: 758 **EFFECTIVE DATE:** December 8, 2016

This letter is intended to supplement the Action Required/Announcement Letter dated June 17, 2016 and provide additional guidance for clients manufacturing products under CCN AVL2 “Appliance Wiring Material – Component” and CCN AVL3 “Appliance Wiring Material- Unlisted Component”

Requirements for production line testing performed by the Manufacturer have been revised. There are three new items in UL 758 that require your attention prior to the Effective Date of December 8, 2016;

- **Appliance wiring material constructed of laminated film insulating material with uninsulated intervals (Section 48.2):** The production line tests on laminated flat constructions of AWM with a purposeful gap in the insulation have been defined. All AWM of this construction must be tested using one of the three methods described in either 48.2.1, 48A, or in the Section General of the individual manufacturer’s Follow-Up Services Procedure.
- **Section 48.2.1** now allows for use of a DC spark tester in lieu of an AC spark tester
- **Production-Line Dielectric Test (section 49):** A DC dielectric tester may be used in lieu of an AC dielectric tester for the production-line testing of shielded cords.

UL Field Representatives will review the required test methods employed at the manufacturing site during their routine inspection visits to verify compliance. Any non-compliance with these requirements after the Effective Date will be identified on a “Held Shipment” Variation Notice (VN). Therefore, please ensure that the required production line test equipment and test methods are in place before the Effective Date.

As stated in the Industry File Review Important Letter, Recognition Coverage on your products will cease and you cannot use the UL Mark unless those products comply with the new requirements on or before December 8, 2016

Should your products be covered in a Multiple Listing (ML), Multiple Recognition or Multiple Classification agreement, or you have an Alternate Listee (AL) arrangement with another company, it is suggested that the company(s) be advised of the status of your products as their Recognition Coverage along with the authorization to use the UL Mark will also cease if your products do not comply with the new and revised requirements on or before the Effective Date.

Any information and documentation involving UL Mark Services are provided on behalf of UL LLC (UL) or any authorized licensee of UL.

We appreciate your participation in UL’s Certification Program and your continued cooperation with UL’s Industry File Review Process.

VERY TRULY YOURS,

CHARLES GARUFI
SENIOR STAFF ENGINEER
CENTRALIZED PHASE ONE REVIEW TEAM
DEPARTMENT 7080AMEL

UL LLC
1285 Walt Whitman Road, Melville, NY 11747-3081 USA
T: 631.271.6200 / F: 631.271.8259 / W: UL.com

Paper Mailed

PART NO.
20278-...R-...

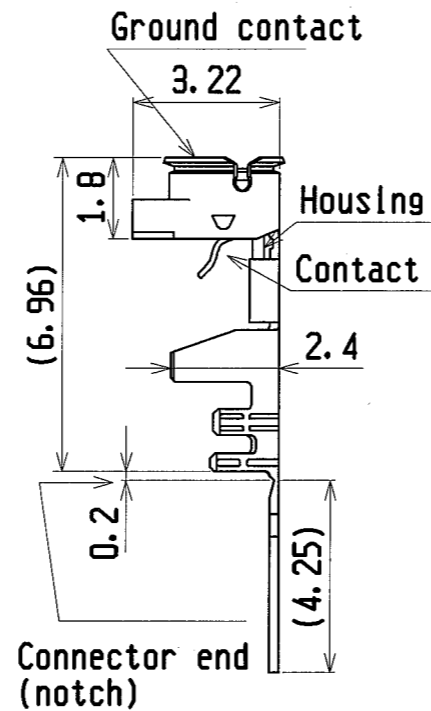
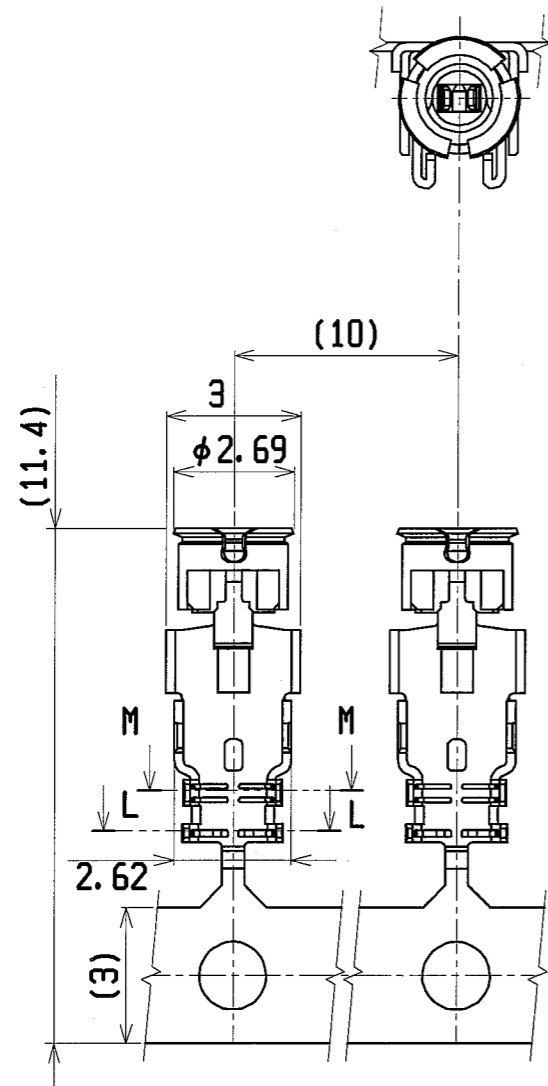

Part No. 20278-101R-08
20278-102R-08
20278-101R-13
20278-102R-13
20278-101R-32
20278-102R-32

For hand tool
(with notch)

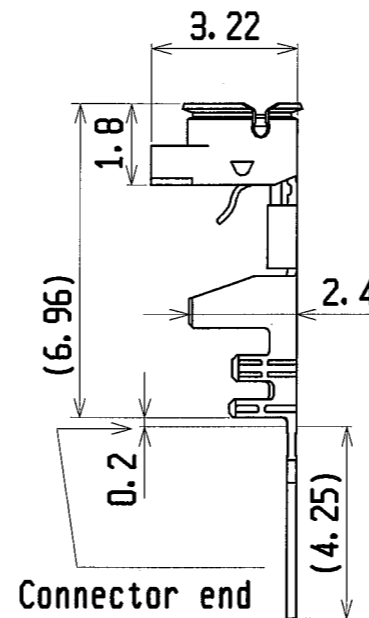

Part No. 20278-111R-08
20278-112R-08
20278-111R-13
20278-112R-13
20278-111R-32
20278-112R-32

For semi auto
termination machine
(without notch)

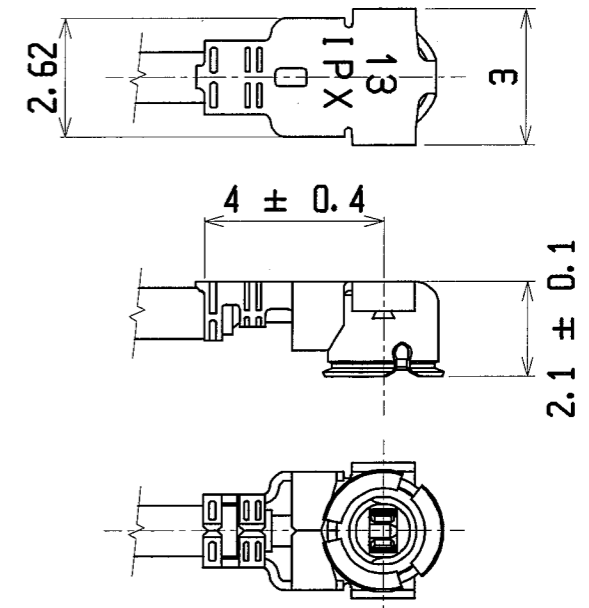

Cable Ass'y

Plug
P/N 20278-1...R-08
P/N 20278-1...R-13
P/N 20278-1...R-32

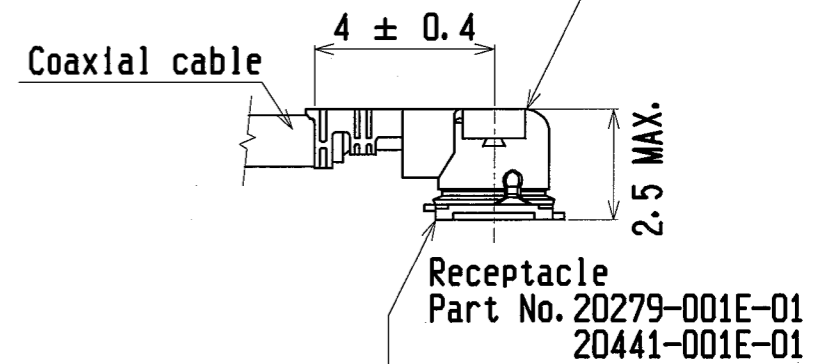

MATING

GENERAL TOLERANCE		
6 MAX.	±0.2	
6 OVER MAX. 30	±0.3	
30 OVER MAX. 120	±0.5	
ANGLE	±2°	

19C	Z08056	K.O	Feb/04/08	EK	DESIGN'D BY	DATE
18C	Z07346	K.O	Jul/10/08	E.K	K. Ohbayashi	JUN/13/01
17C	Z05233	K.O	May/18/05	T.H	CHK'D BY	DATE
16C	Z05024	K.O	Jan/20/05	T.H		
15C	Z04398	K.O	Nov/12/04	T.H	APP'D BY	DATE
REV	ECN	BY	DATE	APP	K. Katabuchi	JUN/13/01
REV. RECORD					CUSTOMER	PROJECTION
SERIES No. 2814					COPY	6/1 mm

I-PEX Interconnect and Packaging Electronics TOKYO, JAPAN

TITLE: MHF series micro coaxial connector plug vertical (ground contact : gold plating)

General

SCALE: 6/1 mm UNIT: mm DWG. No. 20278 SHEET 1/4 REV. 19C

PART NO.
20278-***R-***

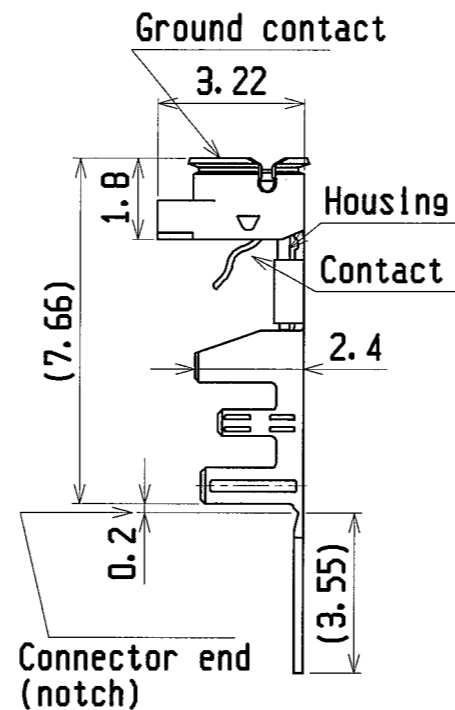
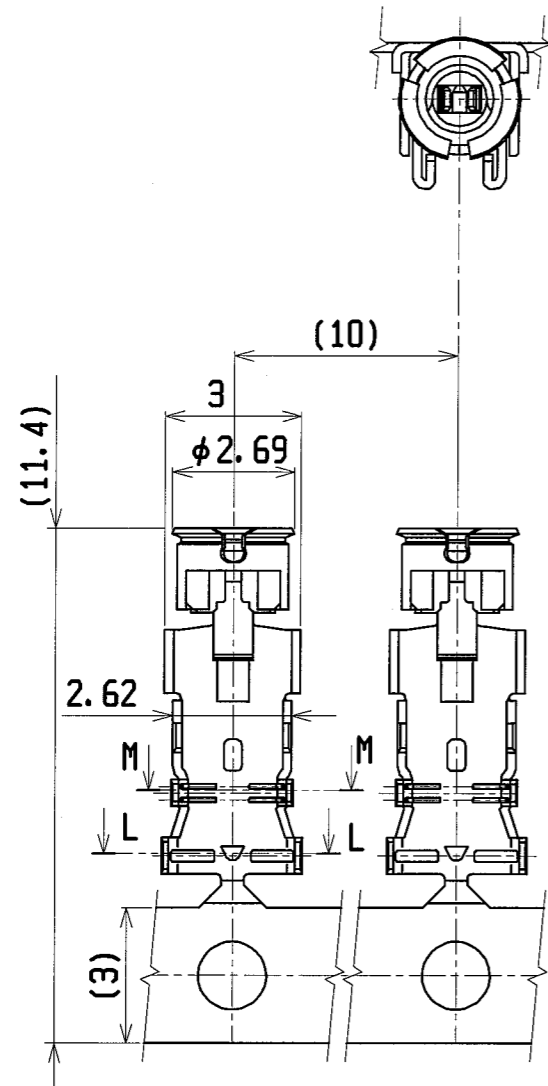

Part No. 20278-101R-18
20278-102R-18
For hand tool
(with notch)

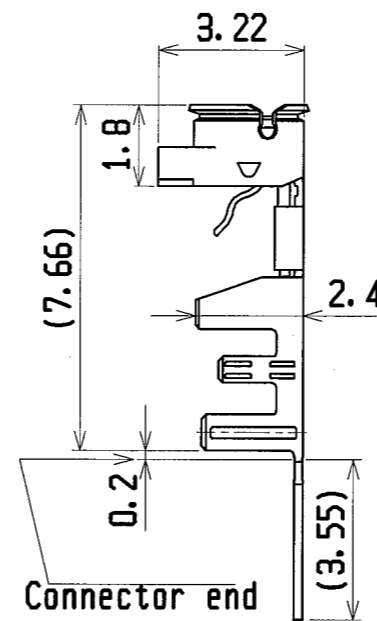

Part No. 20278-111R-18
20278-112R-18
For semi auto
termination machine
(without notch)

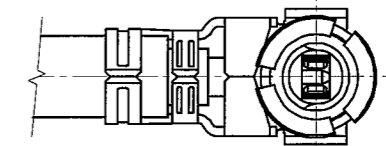
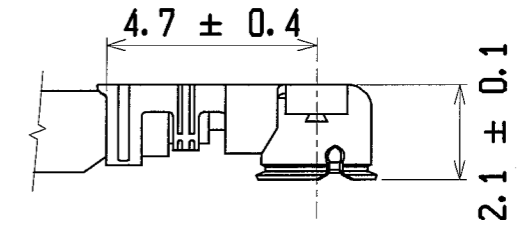
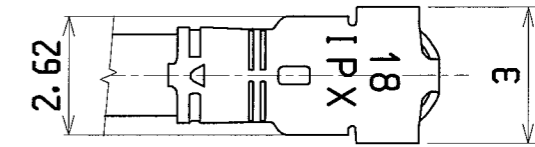

Cable Ass'y

Plug
P/N 20278-1**R-18

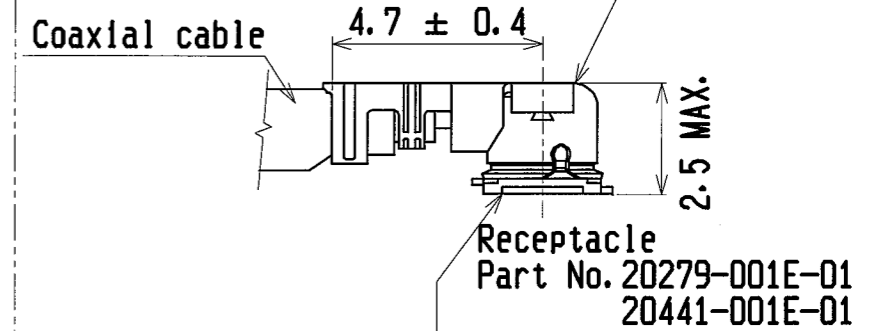

MATING

GENERAL TOLERANCE	
6 MAX.	±0.2
6 OVER MAX. 30	±0.3
30 OVER MAX. 120	±0.5
ANGLE	±2°

DESIGN D BY	DATE	I-PEX Interconnect and Packaging Electronics TOKYO, JAPAN	TITLE MHF series micro coaxial connector plug vertical (ground contact : gold plating) General	
CHK' D BY	DATE			
APP' D BY	DATE			
REV ECN BY DATE APP	CUSTOMER COPY	PROJECTION	SCALE UNIT DWG. No.	SHEET REV.
SERIES No. 2814			6/1 mm 20278	2/4 19C

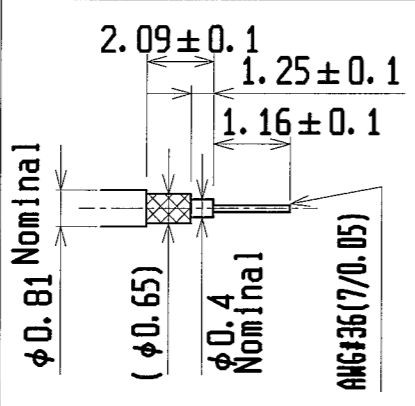
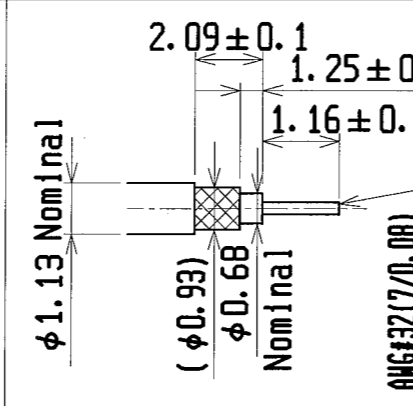
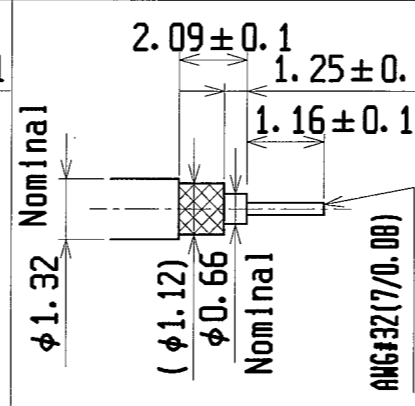
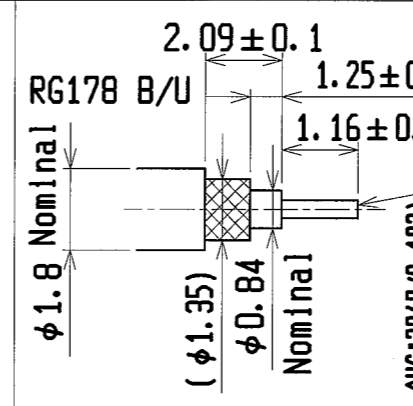
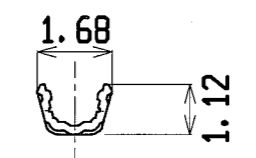
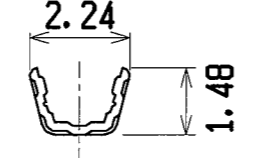
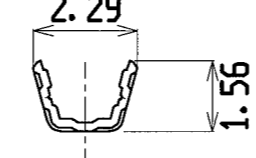
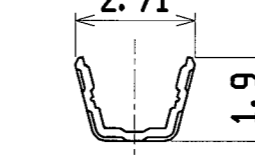
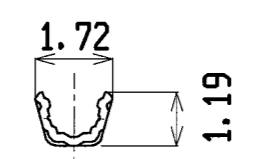
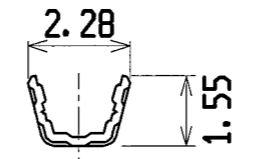
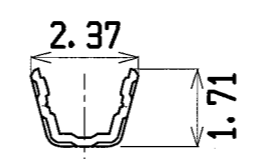
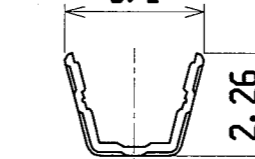
Part No. of non halogen free type	20278-101R-08 20278-111R-08	20278-101R-13 20278-111R-13	20278-101R-32 20278-111R-32	20278-101R-18 20278-111R-18	
Part No. of halogen free type	20278-102R-08 20278-112R-08	20278-102R-13 20278-112R-13	20278-102R-32 20278-112R-32	20278-102R-18 20278-112R-18	
Housing color	White	Black	Black	White	
Applicable cable nominal dimension	 2.09 ± 0.1 1.25 ± 0.1 1.16 ± 0.1 $\phi 0.81$ Nominal $(\phi 0.65)$ $\phi 0.4$ Nominal AWG#36(7/0.05)	 2.09 ± 0.1 1.25 ± 0.1 1.16 ± 0.1 $\phi 1.13$ Nominal $(\phi 0.93)$ $\phi 0.68$ Nominal AWG#32(7/0.08)	 2.09 ± 0.1 1.25 ± 0.1 1.16 ± 0.1 $\phi 1.32$ Nominal $(\phi 1.12)$ $\phi 0.66$ Nominal AWG#32(7/0.08)	 2.09 ± 0.1 1.25 ± 0.1 1.16 ± 0.1 $\phi 1.8$ Nominal RG178 B/U $(\phi 1.35)$ $\phi 0.84$ Nominal AWG#30(7/0.102)	
Braided shield of Outer conductor 外部導体の編組	Single / 1重編組	Single / 1重編組	Double / 2重編組	Single / 1重編組	
P/N of hand Tool	90187-008C	90187-013C	90187-032C	90233-018	
P/N of semi auto termination machine	90213-008C	90213-013C	90213-032C	90232-018	
Sect. M-M	 1.68 1.12	 2.24 1.48	 2.29 1.56	 2.71 1.9	
Sect. L-L	 1.72 1.19	 2.28 1.55	 2.37 1.71	 3.1 2.26	
Crimp Height	CH-1	1.34~1.40	1.34~1.40	1.34~1.40	1.34~1.40
	CH-2	0.76~0.84	1.06~1.14	1.20~1.30	1.41~1.49
	CH-3	0.85~0.97	1.15~1.35	1.26~1.46	1.70~1.80

Cable cut length

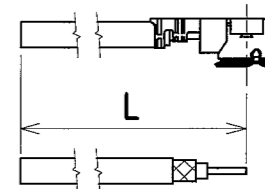

Crimp Height

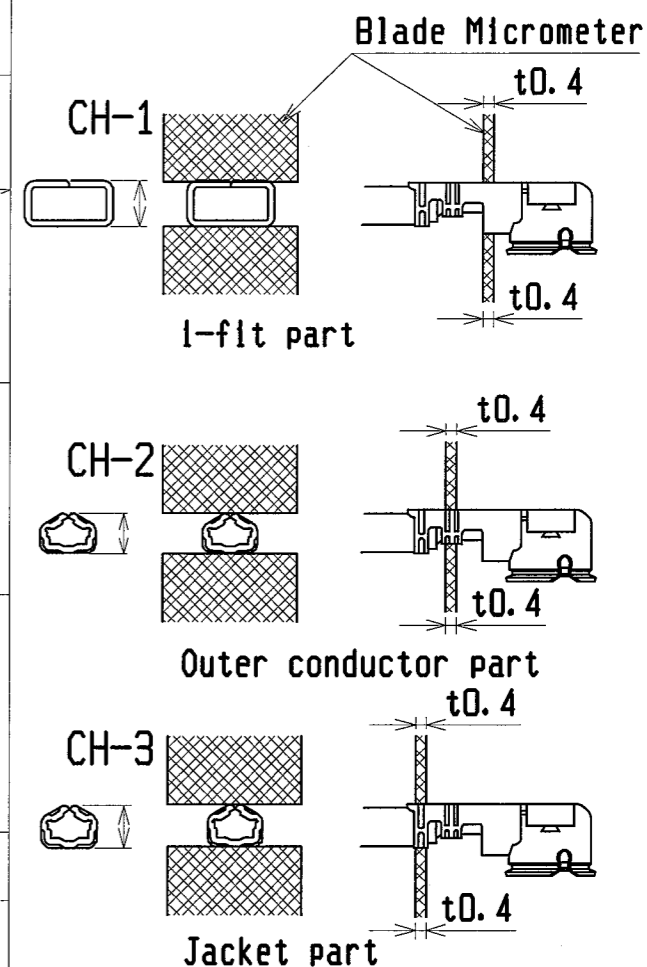

NOTE-1

中心導体, 外部導体への半田コーティングは不可
Must not use solder coated
Inner conductor and outer conductor.

DESIGN D BY	DATE	 I-PEX Interconnect and Packaging Electronics TOKYO, JAPAN	General							
CHK' D BY	DATE									
APP' D BY	DATE									
REV	ECN	BY	DATE	APP	TITLE	SCALE	UNIT	DWG. No.	SHEET	REV.
REV. RECORD					CUSTOMER COPY	PROJECTION	mm	20278	3/4	19C
SERIES No. 2814										

Notes

1. Material

- (1) Housing : PBT , UL94V-0
- (2) Contact
phosphor bronze
gold plating 0.1 μ m MIN.
over nickel 1.27 μ m MIN.
- (3) Ground contact
phosphor bronze
gold plating 0.05 μ m MIN.
over nickel 1.27 μ m MIN.

2. Packing : reel

3. Mating partner part No.
: 20279-001E-01, 20441-001E-01

4. Permissible load of cable at mating

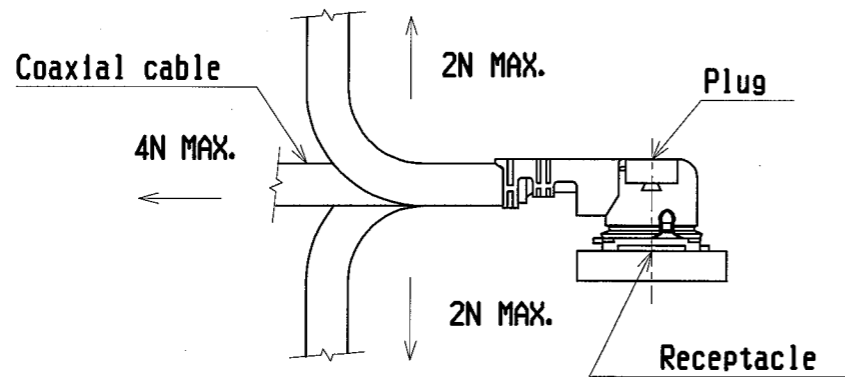

5. Suggestions for mating & unmating operation.

5-1 Mating.

Please mate the connector straightly to vertical direction as much as possible, adjusting the mating axis of plug and receptacle. As excessive slant angle mating may break the connector, please don't do it.

1. 材料

- (1) ハウジング : PBT, UL94V-0
- (2) コンタクト
りん青銅
金メッキ0.1 μ m MIN.
下地 ニッケル1.27 μ m MIN.
- (3) グランドコンタクト
りん青銅
金メッキ0.05 μ m MIN.
下地 ニッケル1.27 μ m MIN.

2. 梱包 : リール

3. かん合相手 part No.
: 20279-001E-01, 20441-001E-01

4. コネクタかん合後のケーブルに対する荷重

5. コネクタかん合時および抜去時の注意

5-1 コネクタ挿入時

PlugとReceptacleのかん合軸を合わせ、できるだけ垂直に挿入して下さい。極端な斜め挿入は行わないで下さい。コネクタ破損の原因となりますので、過度なこじり挿入は行わないで下さい。

5-2 Unmating.

- (1) In case of unmating by pulling tool.
Please use the pulling tool as the following drawing, and please pull plug to vertical direction as directly as possible.

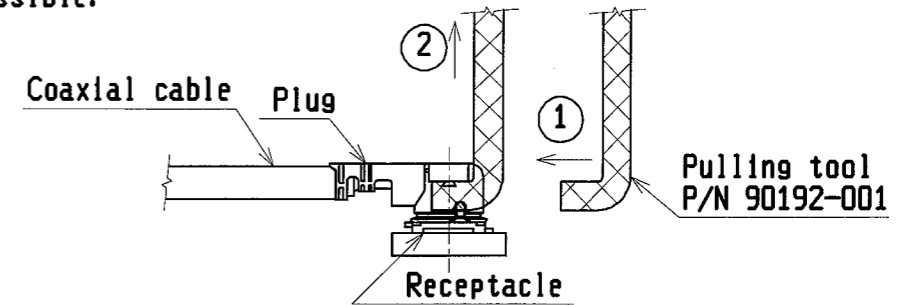

- (2) In case of unmating directly by hand
Please catch the catching area of plug, and please pull plug to vertical direction as directly as possible.

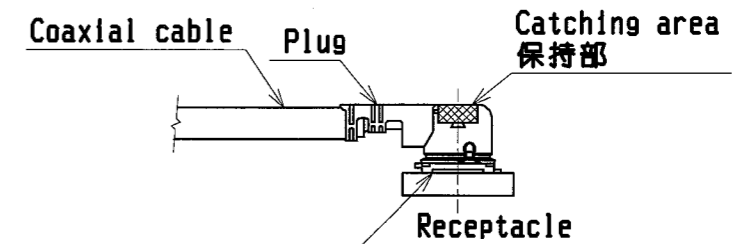

5-3 Crimp over standards of outer conductor

Standards: Less than 10% from total numbers of outer conductor
(Numbers of outer conductor's crimp over from outer conductor's barrel)

5-4 Caution about Heat shrinkage tubes

Please be careful not to melt housing when using heat shrinkage tubes. It will become cause of open circuit.

6. This is 'Pb-free' connector.

5-2 コネクタ抜去時

- (1) 抜去ジグを用いる場合
下図のようにできるだけ垂直に引き抜いて下さい。

- (2) 手で直接引き抜く場合
下図の保持部をつかみ、できるだけ垂直に引き抜いて下さい。

5-3 外部導体はみ出し量

外部導体はみ出し量規定 : 外部導体トータル本数の10%以下 (外部導体パレルの外にはみ出し量)

5-4 熱収縮チューブについての注意

熱収縮チューブで外部導体を覆う場合は、導通不良の原因となりますので、熱によりハウジングを溶融させないように注意してください。

6. 本コネクタは'Pb-free'である

GENERAL TOLERANCE	
6 MAX.	±0.2
6 OVER MAX. 30	±0.3
30 OVER MAX. 120	±0.5
ANGLE	±2°

DESIGN'D BY	DATE	Interconnect and Packaging Electronics TOKYO, JAPAN	TITLE MHF series micro coaxial connector plug vertical (ground contact : gold plating)	General	
CHK'D BY	DATE				
APP'D BY	DATE				
REV	ECN	BY	DATE	APP	SCALE UNIT DWG. No. SHEET REV. -/- mm 20278 4/4 19C
REV. RECORD SERIES No. 2814					CUSTOMER COPY PROJECTION

No.06027-1
Feb / 26/'08

材料証明書
MATERIAL CERTIFICATE

当社製品には下記の材料が使われている事を証明致します。

WE HEREBY CERTIFY THAT THE FOLLOWING MATERIALS ARE USED IN OUR PRODUCT.

PRODUCT NAME : MHF series micro coaxial connector PLUG & RECEPTACLE VERTICAL

Plug, Non halogen free type

Part No.	Contents	Housing	Contact	Ground contact
20278-101R-08	材質名/ Material	PBT	Phosphor bronze	Phosphor bronze
20278-111R-08				
20278-101R-13	型名/ Cat No.	DURANEX 3116	C5210R-H	C5191R-1/2H
20278-111R-13				
20278-101R-32	材料メーカー	WINTECH POLYMER LTD.	Nippon Mining & Metals Co.,Ltd.	HARADA METAL INDUSTRY Co.,Ltd.
20278-111R-32	Manufacturer			
20278-101R-18				
20278-111R-18	UL94難燃性	V-0	-----	-----
20308-101R-13	UL94 flame			
20308-111R-13	class			
20308-101R-32				
20308-111R-32	UL file No.	E213445	-----	-----
20351-101R-37				
20351-111R-37				

※添付資料 : ULカード写し/UL CARD COPY

APPROVAL	CHECK	ORIGINATOR
T.Harada Feb/26/'08	T.Tagawa Feb/26/'08	K.Ohbayashi Feb/26/'08

Plug, Halogen free type

Part No.	Contents	Housing	Contact	Ground contact
20278-102R-08	材質名/ Material	PBT	Phosphor bronze	Phosphor bronze
20278-112R-08	型名/ Cat No.	XFR4840 GF10	C5210R-H	C5191R-1/2H
20278-102R-13	材料メーカー	WINTECH POLYMER LTD.	Nippon Mining & Metals Co.,Ltd.	HARADA METAL INDUSTRY Co.,Ltd.
20278-112R-13	Manufacturer			
20278-102R-32	UL94難燃性	V-0	-----	-----
20278-112R-32	UL94 flame			
20278-102R-18	class			
20278-112R-18	UL file No.	E213445	-----	-----
20351-102R-37				
20351-112R-37				

※添付資料：ULカード写し／UL CARD COPY

Receptacle

Part No.	Contents	Housing	Contact	Ground contact
20279-001E-01	材質名/ Material	LCP	Brass	Phosphor bronze
20314-001E-01	型名/ Cat No.	VECTRA E130i	C2680R-o	C5191R-1/2H
	材料メーカー	Polyplastics Co.,Ltd	Nippon Mining & Metals Co.,Ltd.	HARADA METAL INDUSTRY Co.,Ltd.
	Manufacturer			
	UL94難燃性	V-0	-----	-----
	UL94 flame			
	class			
	UL file No.	E 106764	-----	-----

※添付資料：ULカード写し／UL CARD COPY

QMFZ2 Component – Plastics

Friday, October 24, 2003

E213445

WINTECH POLYMER LTD

18-1 KONAN 2-CHOME MINATO-KU TOKYO 108-8280 JP

Material Designation: **3116(e)**

Product Description: Polybutylene Terephthalate (PBT), designated "Duranex" furnished as pellets.

Color	Min. Thick. (mm)	Flame Class	HWI	HAI	RTI Elec	RTI Imp	RTI Str	IEC GWIT	IEC GWFI
ALL	0.75	V-0	4	0	130	–	130	–	–
	1.5	V-0	3	0	130	120	130	–	–
NC, BK	3	5VA	2	0	130	120	130	–	–
CTI: 2	IEC CTI (V): –	HVTR: 3			D495: 6			IEC Ball Pressure (° C): –	
Dielectric Strength (kV/mm): 23		Volume Resistivity (10⁹ohm-cm): 16						Dimensional Stability(%):0.0	
ISO Tensile Strength (MPa): –		ISO Flexural Strength (MPa): –						ISO Heat Deflection (C): –	
ISO Tensile Impact (kJ/m²): –		ISO Izod Impact (kJ/m²): –						ISO Charpy Impact(kJ/m²): –	

(e) Virgin and regrind from 1 to 50 by weight incl. have the same basic material characteristics (at a minimum thickness of 0.75 mm), except for 310EP which has a lower as received Tensile Impact value from 26 to 50 percent regrind.

Report Date: 11/15/2000

Underwriters Laboratories IncR

UL94 small-scale test data does not pertain to building materials, furnishings and related contents. UL 94 small-scale test data is intended solely for determining the flammability of plastic materials used in components and parts of end-product devices and appliances, where the acceptability of the combination is determined by ULI.

Component - Plastics

E213445

WINTECH POLYMER LTD

18-1 KONAN 2-CHOME, MINATO-KU, TOKYO 108-8280 JP

XFR 4840 GF10

Polybutylene Terephthalate (PBT), "Duranex", furnished as pellets

Color	Min Thk (mm)	Flame Class	HWI	HA1	RTI Elec	RTI Imp	RTI Str
ALL	0.75	V-0	1	0	75	75	75
	1.5	V-0	1	0	75	75	75
	3.0	V-0	1	0	75	75	75

Comparative Tracking Index (CTI): **1**

Dimensional Stability (%): -

High-Voltage Arc Tracking Rate
(HVTR): **0**High Volt, Low Current Arc Resis (D495): **5**Dielectric Strength (kV/mm): **24**Volume Resistivity (10xohm-cm): **14**

UL94 small-scale test data does not pertain to building materials, furnishings and related contents. UL94 small-scale test data is intended solely for determining the flammability of plastic materials used in the components and parts of end-product devices and appliances, where the acceptability of the combination is determined by ULI.

Report Date: 2006-07-24

Last Revised: 2006-07-25

Underwriters Laboratories Inc®

**IEC and ISO Test Methods**

Test Name	Test Method	Units	Thickness Tested (mm)	Value
IEC Flammability	IEC 60695-11-10	Class (color)	0.75	V-0 (ALL)
			1.5	V-0 (ALL)
			3.0	V-0 (ALL)
Glow-Wire Flammability (GWFI)	IEC 60695-2-12	C	-	-
Glow-Wire Ignition (GWIT)	IEC 60695-2-13	C	-	-
IEC Comparative Tracking Index	IEC 60112	Volts (Max)	-	-
IEC Ball Pressure	IEC 60695-10-2	C	-	-
ISO Heat Deflection (1.80 MPa)	ISO 75-2	C	-	-
ISO Tensile Strength	ISO 527-2	MPa	-	-
ISO Flexural Strength	ISO 178	MPa	-	-
ISO Tensile Impact	ISO 8256	kJ/m2	-	-
ISO Izod Impact	ISO 180	kJ/m2	-	-
ISO Charpy Impact	ISO 179-2	kJ/m2	-	-

Underwriters Laboratories Inc®

QMFZ2 Component - Plastics

Friday, October 24, 2003

E106764

POLYPLASTICS CO LTD

VECTRA DIV 18-1 KONAN 2-CHOME MINATO-KU TOKYO 108-8280 JAPAN

Material Designation: **E130i(d)(e)**

Product Description: Liquid Crystal Polymer (LCP), thermotropic aromatic polyester, designated "Vectra" furnished as pellets.

Color	Min. Thick. (mm)	Flame Class	HWI	HAI	RTI Elec	RTI Imp	RTI Str	IEC GWIT	IEC GWFI
ALL	0.75	V-0	2	4	240	220	240	-	-
	1.5	V-0	1	4	240	220	240	-	-
	3.0	V-0	0	4	240	220	240	-	-
CTI: 4		HVTR: 0		D495: 5			IEC Ball Pressure (°C): -		
Dielectric Strength (kV/mm): 39		Volume Resistivity (10⁸ohm-cm): 16			Dimensional Stability(%): 0				
ISO Tensile Strength (MPa): -		ISO Flexural Strength (MPa): -			ISO Heat Deflection (°C): -				
ISO Tensile Impact (kJ/m²): -		ISO Izod Impact (kJ/m²): -			ISO Charpy Impact (kJ/m²): -				

(d) Virgin and regrind up to 50% by weight incl. have the same basic material characteristics for colors NC and BK.

(e) In addition, regrind at 26 to 50% have the same basic characteristics at a minimum of 1.5mm except RTI's for the Mechanical w/Impact property is 180C.

Report Date: 8/19/1992

Underwriters Laboratories Inc®

UL94 small-scale test data does not pertain to building materials, furnishings and related contents. UL 94 small-scale test data is intended solely for determining the flammability of plastic materials used in components and parts of end-product devices and appliances, where the acceptability of the combination is determined by ULI.

MATERIAL SAFETY DATA SHEET (MSDS)

Issued: Feb 6 , 2013

Revised: Feb 6 , 2013

File No. 2302-1

1. CHEMICAL PRODUCT & COMPANY IDENTIFICATION

CHEMICAL PRODUCT NAME : DURANEX® 310NF ED3002
NAME OF COMPANY : WinTech Polymer Ltd.
SECTION IN CHARGE : Quality Assurance Dept.
ADDRESS : 2-18-1 Konan, Minato-ku, Tokyo,108-8280 Japan
TELEPHONE NUMBER : 03-6711-8605
FACSIMILE NUMBER : 03-6711-8616

2. HAZARDS IDENTIFICATION

【GHS CLASSIFICATION】 :

•Physical and Chemical Hazards : Flammable solids : Classification not possible
Self-reactive substances and mixtures : Not applicable
Pyrophoric solids : Not classified
Self-heating substances and mixtures : Classification not possible
Substances and mixtures, which in contact with water, emit flammable gases : Not classified
Oxidizing solids : Not classified
Corrosive to metal : Not classified

•Health Hazards : •Carcinogeneses : Category 2
•Specific target organ/systemic toxicity (Repeated exposure) : Category 1 (Lung)

•Environmental Hazards : Classification not possible

【SYMBOL】 : ⚠(Flame), ⚠(Health Hazard)

【SIGNAL WORD】 : Danger

【HAZARD STATEMENT】 : Suspected of causing cancer.
Causes damage to organs(Lung) through prolonged or repeated exposure.

【PRECAUTIONARY STATEMENTS】 :

•Prevention : •Wash hands thoroughly after handling.
•Wear protective gloves.

•Response :

•Storage : •Avoid direct sunlight and store in a well-ventilated place.

•Disposal : •Dispose of contents/container in accordance with local & national regulations.

【REMARKS】 : Hazards information result from carbon black, not from our product itself.

3. COMPOSITION/INFORMATION ON INGREDIENTS

SUBSTANCE/PREPARATION : Preparation

COMMON CHEMICAL NAME : Polybutyleneterephthalate

SYNONYMS : Polybutyleneterephthalate(PBT)

INGREDIENTS AND COMPOSITION : PBT \geq 59.5%, Glass fiber 10%, Carbon black \leq 0.5%
Phosphorus Flame retardant and others \leq 30%

CHEMICAL FORMULA	: $\left[\text{C}_6\text{H}_4\text{O}(\text{CH}_2)_4\text{O} \right]_n$
SERIAL No. IN OFFICIAL GAZETTE	: 7-1039 (base resin) (Law Concerning Examination and Regulation of Manufacture, etc., of Chemical Substances)
CAS No.	: 24968-12-5 (base resin)

4. FIRST-AID MEASURES

INGESTION	: Help to vomit as much as possible. If sick feeling continues, and ask a physician for advice.
INHALATION	: When a gas generated from the molten polymer, especially fume generated during combustion or heat, has been inhaled, remove fresh air without delay and wait until the victim is recovered. If sick feeling continues, ask a physician for advice.
SKIN CONTACT	: Cool the contacted skin with clean water without delay, if a contact with the polymer in a molten form. Do not force to remove the solid resin on the skin. If any burns are observed on the skin, ask a physician for advice.
EYE CONTACT	: Cool and rinse the eye with clean water for at least 15 minutes when the eyes had contact with molten polymer. In case of wearing contact lenses, remove the lenses as soon as possible, and ask a physician for advice. When the eye had contact with the polymer in an ordinary solid form, rinse the eye with clean water without delay. If the discomfort persists, ask a physician for advice.

5. FIRE-FIGHTING MEASURES

EXTINGUISHING MEDIA	: Water, foam fire-extinguishing agent, powder fire-extinguishing agent, and carbon dioxide gas.
SPECIFIC METHODS	: Extinguish the fire with water. A method of extinguishing an ordinary fire may be applied. Do not apply water directly to processing machines.
SPECIFIC HAZARDS	: Incomplete combustion leads to generation of toxic gases such as carbon monoxide or tetrahydrofuran, in addition to carbonic acid gas and water.
SPECIAL EQUIPMENT FOR THE PROTECTION OF FIREFIGHTERS	: In case the fire gained force, use a gas mask or other protective equipment.

6. ACCIDENTAL LEAKAGE MEASURES

PERSONAL PRECAUTIONS	: When pellets were spilled on the road or floor, wipe them off with a broom or cleaner not to cause slipping.
ENVIRONMENTAL PRECAUTION	: Handle the spillage in accordance with provisions given in the "Resin pellet spillage preventive manual", in order to prevent intakes by marine animals and birds.

7. HANDLING AND STORAGE

HANDLING	: This resin in a pellet form will neither ignite nor explode at room temperatures.
HANDLING 2	: For molding work, effective means for local exhaust are required to discharge gases generated by melt processing.
HANDLING 3	: Avoid inhaling of gases generated in moulding work. Do not directly touch resin of high temperature.
HANDLING 4	: Avoid retaining hot resin in the processing machines for many hours.
HANDLING 5	: This pellets spilled on the floor are likely to cause slipping. Remove such spillage at any times.

HANDLING 6	: Glass fibers are not generally exposed in a single substance under normal processing and handling conditions as they are compounded in pellets. However, the following measures will be necessary to minimize the exposure to glass fibers or dusts containing glass fibers, when pellets or molded parts containing glass fibers are cut, ground or burnt, depending on environmental and operational conditions. <ul style="list-style-type: none"> • Those who are sensitive in skin to glass fiber should wear suitable (protective) clothes to minimize the exposure of their skin. • Wash working clothes apart from other laundry, so that the latter will not cause contamination with glass fibers. • Provide the workshop with partitions to prevent diffusion of glass fiber dusts. • Pay precautions not to rub face, neck or arms with hands. Wash hands and gargle after working without fail. • Keep dust sources totally enclosed. • Provide local air exhausters and implement periodical inspections and adjustments at least once a year. • Reduce cutting and grinding processes to the possible minimum, and devise working procedures to minimize dust generation. • Provide dust-preventive masks, protective glasses and gloves for personal hygiene. • Determine the operational environment at indoor working places and confirm the effects of environmental improvement. Note) Glass fibers are, like road dusts, told to be least hazardous to human bodies, but proper measures are required to avoid useless inhaling.
STORAGE	: Keep the substance away from any fire or heat sources for the sake of safe storage.
RECOMMENDED PACKAGING MATERIALS	: No information.

8. EXPOSURE CONTROL / PERSONAL PROTECTION

CONTROL CONCENTRATION	: None at present
PERMISSIBLE CONCENTRATION	: OSHA PEL/1985 Max. permissible concentration of inactive powder 15mg/m ³ - ditto - (Aspiration) 5 mg/m ³ ACGIH TLV/1992 1993 Exposure limit of the powder TWA 10 mg/m ³
ENGINEERING MEASURE	: When handling dust: Use totally enclosed containers resisting dust explosion. When heat melted in molding: Effective local ventilation must be provided.
PERSONAL PROTECTIVE EQUIPMENT	:
RESPIRATORY PROTECTION	: Wear a dust-proof mask.
EYE PROTECTION	: Wear protective glasses or goggles.
HAND PROTECTION	: Wear heat-resisting gloves against burns, when handling molten polymer.
SKIN & BODY PROTECTION	: Wear long sleeve clothes against burns, when handling molten polymer.

9. PHYSICAL AND CHEMICAL PROPERTIES

APPEARANCE etc.	: Pellet
BOILING POINT	: Not applicable

VAPOUR PRESSURE	: Not applicable
VOLATILITY	: Not applicable
SUBLIMATION	: None
MELTING POINT	: 228°C
DENSITY	: 1.40g/cm ³
SOLUBILITY	: Insoluble in water
FLASH POINT	: 300°C or higher
IGNITION POINT	: 300°C or higher
EXPLOSION PROPERTY	: Not applicable
INFLAMMABILITY	: None
REACTIVITY WITH WATER	: None
OXIDIZABILITY	: None
SELF-REACTIVITY	: None
DUST EXPLOSIVENESS	: Upper explosion limit : Not applicable. Lower explosion limit : 35g/m ³

10. STABILITY AND REACTIVITY

STABILITY AND REACTIVITY	: Stable for normal storage or handling.
--------------------------	--

11. TOXICOLOGICAL INFORMATION

SKIN CORROSIVE PROPERTIES	: No finding.
SENSITIZING & IRRITANT EFFECTS	: Gas generated in drying or melting is irritating eyes and skins.
ACUTE TOXICITY(INCLUDING LD50)	: No finding.
SUBACUTE TOXICITY	: No finding.
CHRONIC TOXICITY	: The product contains the substance that causes damage to lung and respiratory through prolonged or repeated exposure.(CB)
CARCINOGENECITY	: The product contains the substance of carcinogenic category 2 in the GHS classification.(CB)
MUTAGENECITY(Micro organisms,chromosomal aberration)	: No finding.
REPRODUCTIVE TOXICITY	: No finding.
TERATOGENICITY	: No finding.
OTHERS(Including generation of hazardous gases by reaction with water,for example)	: No finding in this report means that there will be no hazard in general,but no proving data available at the time of reporting.
OTHER CAUTIONS	: With regard to dust,the maximum permissible concentration and limits are fixed by OSHA and ACGIH.

OTHER CAUTIONS : Information on hazards of glass fibers as filler.
2 <Effects on Human Bodies>

(1) Effects on skin

Stimulation to the skin with glass fibers may be caused when glass fibers diameter is larger than $4.5 \sim 5 \mu\text{m}$. They give mechanical stimulation followed by itchiness to the skin, but further continuous exposure reportedly results in extinction of stimulation. It may sometimes leads to irritable dermatitis complicated with urticaria or eczema-like reaction. It is, however reported that such dermatitis is not so serious in general and does not last too long. Therefore, skin stimulation can be prevented by proper use of glass fibers.

(2) Effects on Tumor

Investigations made on glass fibers till today reveal that there is neither increase in mortality of glass fiber production workers due to lung cancer or mesothelioma nor such cases reported.

<Animal Test Report>

It is suggested that carcinogenicity of mineral fibers is dependent on their shapes rather than on their constituents. According to a report on experiments using 17 kinds of artificial mineral fibers in various sizes prepared by Dr.Stanton of National Cancer Institute, in USA, statistical studies on corelations between the diameter and length of fibers and the coincidence of mesothelioma have revealed that mineral fibers having a diameter smaller than $0.25 \mu\text{m}$ and a length larger than $8 \mu\text{m}$ are closely related to the coincidence of cancers. Since these experiments were performed by artificially dosing the subject animals with a large quantity of glass fibers and consequently they are quite different from the actual exposures to human bodies, it is told to be problematic to make a conclusion that mineral fibers are hazardous to human health, basing on the results obtained from these experiments. Upto the present time, there is no result obtainable to demonstrate a mechanism of glass fibers causing lung cancers in spite of experiment by long exposure to glass fibers with high concentration.

OTHER CAUTIONS : Toxicological information of Carbon black which is an ingredient is
3 shown below. Toxicity of the ingredient does not appear as product for pellet. When dust is generated by cutting and sanding, toxicity appears. Avoid breathing dust and avoid generating dust.

[Carbon black]

Acute toxicity

Oral: Rat LD50 15,400mg/kg GHS Not classified

Dermal: No information

Inhalation: No information

Skin Corrosion/Irritation: No information

Eye Damage/Irritation: No information

Sensitization-Skin: No information

Germ Cell Mutagenicity: No information

Carcinogenicity: IARC 2B; Possible carcinogenic to humans.

Toxicity to Reproduction: No information

Specific Target Organ Toxicity(Single Exposure)

No information

Specific Target Organ Toxicity(Repeated Exposure)

Category 1 based on the influence on lungs (the hyperplasia of the epithelium, pulmonary fiber symptom) in pneumoconiosis of human and a rat inhalational examination in the range of guidance level Category 1

Aspiration Hazard: No information

REMARKS : Hazards information and so on result from the national classification of carbon black.

12. ECOLOGICAL INFORMATION

BIODEGRADABILITY : No finding.

BIOACCUMULATIO : No finding.

N

FISH TOXICITY : No finding.

13. DISPOSAL CONSIDERATION

- WASTE FROM RESIDUES : This is designated as waste plastics among industrial wastes by the Wastes Disposal Law. Disposal waste pellets through licensed wastes handlers or local autonomous bodies if they are handling wastes disposal.
- WASTE FROM RESIDUES 2 : When disposed by incineration, use the well controlled incinerators in accordance with the Wastes Disposal Law, Air Pollution Control Law and Water Pollution Prevention Law.
-

14. TRANSPORT CONSIDERATION

- UN CLASSIFICATION NUMBER : Not applicable
- OTHER CAUTIONS : Handle with care so as not to give damages to containers or not to be subjected to wetting.
- OTHER CAUTIONS : Secure the containers firmly so as not to cause collapsing.
2
-

15. REGULATORY INFORMATION

- WASTE DISPOSAL LAW : Waste plastics among industrial wastes.
- INDUSTRIAL SAFETY AND HEALTH LAW : Designated as Cabinet order No.93 Annex 9 No.130.(Carbon black)
-

16. OTHER INFORMATION

- HANDLING OF THE DETAILS GIVEN ABOVE : This MSDS is the English version translated from the Japanese MSDS which is prepared for domestic use. Details given above are based on references, information and data available at this moment, but no warranty can be made on exactness of these details. They are also prepared on the assumption that the product will be handled in a normal way. For special handling, adequate safety and environmental measures should be taken in respect to its applications. Our products are not specifically intended for implants for medical and dental applications, and therefore they are not recommended for such applications. "No finding" in this report means that there will be no hazard in general, but no proving data is available at the time of reporting.
- WHERE TO CALL FOR FURTHER INFORMATION : WinTech Polymer Ltd. Quality Assurance Dept.
Tel. No 03-6711-8605

苏州博联铜业有限公司产品质量证书

证书顺序号: 20200807001

用户	苏州正旭		技术标准	JIS H3100		合同号	样品
产品名称	牌号	规格mm	长度m	数量	重量Kg	等级	批号
铅黄铜棒	C3604	Φ4.5	2.5		按实际发货	A	20200806001
化学成分%							
Cu	Zn	Pb	Fe	Ni	Sn	Mn	其他
58.0453	38.5867	2.7954	0.2412	0.1021	0.2258	0	无
工艺力学性能							
状态	抗拉强度Mpa	延伸率%	硬度HV	状态	公差	尺寸	表面质量
合格	328	15.31	92	1/2H	合格	合格	合格

产品信息

客户须知	售后服务
<p>1、凡提出异议, 请注明质量证书合同号、牌号、规格、日期、异议内容、并在7个工作日内提出。</p> <p>2、对有质量异议的产品, 未协调好以前不得继续投入使用, 否则, 视质量异议不成立。</p> <p>3、本公司负责对有质量问题材料进行更换或退货, 不承担客户提出的加工赔偿要求及其他损失。</p> <p>4、客户主动索要质保书, 过期、遗失等本公司不再增补, 仅限于相对应批次材料使用。</p> <p>5、无质量证明书专用章无效, 复印件无效。</p>	<p>服务电话: 13962535781</p> <p>公司网址: http://www.szblty.com/</p> <p>传真号码: 0512-63808992</p> <p>邮箱地址: blty2992@163.com</p> <p>公司地址: 苏州市吴江区七都镇建设路88号</p>

核准人: 宋振华

检验员:

张月泉

盖章确认:



日期:

2020-8-7

Material Safety Data Sheet (MSDS)

物质安全数据表

SECTION 1. IDENTIFICATION OF THE SUBSTANCE/PREPARATION AND OF THE COMPANY

第一部分 物质/配制品/公司名称

1.1 Identification of the chemical (substance or preparation)

化学品（物质或配制品）名称：BRASS

1.2 Use of the chemical

化学品用途：五金机械类加工用

1.3 Company identification

公司信息

Company name 公司名：苏州博联铜业有限公司
Address 地址：江苏省吴江市七都镇建设路 88 号
Postal code 邮编：2152034
Country 国家：中国
Telephone number 电话：0512-63808992
Fax number 传真：0512-63808992

E-Mail (person responsible for MSDS) 责任人邮箱：blty2992@163.com

Date of latest version MSDS 最新版日期：2018-7-15

1.4 Emergency Telephone

应急电话

In case of an emergency, please contact: 紧急情况请联系：0512-63808992

SECTION 2. HAZARDS IDENTIFICATION

第二部分 危险鉴定

按法规的标准不属于有害品类

SECTION 3. COMPOSITION/INFORMATION ON INGREDIENTS

第三部分 成分组成信息

3.1 General Chemical Description

铜金属表面覆镍和锡膜之金属结构

3.2 Base Substances of Preparation

配制品基本成分

components 成分	EC-No.	CAS-No.	Content (% or range) 浓度 (浓度范围)
铜	231-159-6	7440-50-8	57.0%-63.0%
锌	231-111-4	7440-66-6	33.0%-43.0%
铅	--	7439-92-1	0.01%-4.00%

3.3 Declaration of Ingredients according to EC 1907/2006(REACH Regulation) (If necessary)

遵照EC 1907/2006(REACH)成分声明 (如果需要)

<i>Hazardous components</i> 危险成分	<i>EC-No.</i>	<i>CAS-No.</i>	<i>Content (% or range)</i> 浓度 (浓度范围)	<i>Classification</i> 分类
NA 无危害物质				

Please refer to section 16 for an overview of all R-phrases mentioned here.

涉及的所有风险分级 (R-phrases) 请参阅第十六部分。

SECTION 4. FIRST AID MEASURES

第四部分 急救措施

4.1 General information

一般建议

<i>Exposure Route</i> 接触途径	<i>Specific First Aid Measures</i> 具体急救措施
<i>Inhalation</i> 呼吸吸入	热融化后的可能产生重金属熏烟，吸入熏烟可能导致贫血，失眠，体弱等不良状况。
<i>Skin</i> 皮肤接触	热融化的产品可能导致皮肤灼伤(极少发生)。
<i>Eye contact</i> 眼睛接触	极高温融化的熏烟导致眼睛刺痛，过敏(极少发生)。
<i>Ingestion</i> 食入	导致消化不良和可能导致胃部损伤。

4.2 Advice to doctor

医生注意：无

SECTION 5. FIRE-FIGHTING MEASURES

第五部分 消防措施

5.1 Suitable fire-fighting equipment

合适的消防设备

	Suitable 适合	Unsuitable 不适合
Fire fighting equipment 消防设备	不易燃烧，选择适用干粉，泡沫，洒水，二氧化碳灭火器 热的产品喷溅导致灼伤。	无
Protection gear 保护用具	穿著防火衣和佩戴自携式呼吸器	无

5.2 Dangerous decomposition products: 无

5.3 Additional information for firefighters: 无

SECTION 6. ACCIDENTAL RELEASE MEASURES

第六部分 泄露应急处理

6.1 Personal precautions : 无

6.2 Environmental precautions : 产品可回收再用

6.3 Methods for cleaning up/taking up : 产品可回收再用

清除的方法

用惰性物质吸收，做有害废物处理。

SECTION 7. HANDLING AND STORAGE

第七部分 操作处置和储存

7.1 Handling : 无

7.2 Storage

储存环境: 温度-5~40度C, 湿度小于 65%

7.3 Specific use(s)

无

SECTION 8. EXPOSURE CONTROLS / PERSONAL PROTECTION

第八部分 接触控制/个人防护

8.1 Exposure limit values

最大暴露浓度: 外部表面金属高温高湿易氧化, 需按照规格储存。

8.2 Exposure controls

暴露控制: 无相关数据

Environmental exposure controls

环境暴露控制: 无相关数据

SECTION 9. PHYSICAL AND CHEMICAL PROPERTIES

第九部分 理化特性

9.1 General information

常规信息: Appearance 外观: 金黄色的固体

9.2 Important health, safety and environmental information

重要健康、安全和环保信息

Acidity/pH pH值	不适用
Boiling point/boiling range 沸点/沸程	不适用
Flash point 闪点	不适用
Flammability (solid, gas) 易燃性(固体, 气体)	不易燃烧
Explosive properties 爆炸特性	不适用
Oxidising properties 氧化性	不适用
Vapour pressure 蒸汽压力	不适用
Relative density 相对密度	不适用
Solubility 溶解度	不适用
Water solubility 水溶性	不适用
Partition coefficient: n-octanol/water 分配系数: 辛醇/水	不适用
Viscosity 粘度	不适用
Vapour density 蒸汽密度	不适用
Evaporation rate 蒸发率	不适用

9.3 Other information

其它信息: 无

SECTION 10. STABILITY AND REACTIVITY

第十部分 稳定性和反应活性

10.1 Conditions to avoid

应避免的情况: 高温和潮湿

10.2 Materials to avoid

应避免接触的物质: 无

10.3 Hazardous decomposition products: 无相关数据

SECTION 11. TOXICOLOGICAL INFORMATION

第十一部分 毒理学资料

无相关数据

SECTION 12. ECOLOGICAL INFORMATION

第十二部分 生态学资料

12.1 Ecotoxicity

无相关数据

12.2 Mobility

流动性：不适用

12.3 Persistence and degradability

持久性和降解性：不适用

12.4 Bioaccumulative potential

生物累积的潜在可能性：无相关数据

12.5 Results of PBT assessment

PBT评估结果：无相关数据

12.6 Other adverse effects

其它不利影响：无相关数据

SECTION 13. DISPOSAL CONSIDERATIONS

第十三部分 废弃处理

金属材料可回收再使用

SECTION 14. TRANSPORT INFORMATION

第十四部分 运输信息

Classification according to ADR

陆地运输：不是危险品，无相关限制

Classification according to IMDG

海运：不是危险品，无相关限制

Classification according to IATA

航空运输：不是危险品，无相关限制

运输分类可能会因容器的体积和国家或地区的法规而有所不同

SECTION 15. REGULATORY INFORMATION

第十五部分 法规信息

无相关资料

SECTION 16. OTHER INFORMATION

第十六部分 其它信息

无其他的信息

參考文獻	依據我司产品规格书		
製表單位	名稱： 苏州博联铜业有限公司	製表人	张月泉
	地址： 江苏省吴江市七都镇建设路 88 号	製表日期	2018 年 7 月 15 日



深圳市沃尔核材股份有限公司
SHENZHEN WOER HEAT-SHRINKABLE MATERIAL CO.,LTD.

材质证明书

沃尔核材股份有限公司无卤环保型 RSFR-H 热缩套管是一种阻燃型的热收缩套管，组成材料为聚烯烃加适量阻燃剂和助剂。产品中铅 (Pb)、镉 (Cd)、汞 (Hg)、六价铬 (Cr⁶⁺)、多溴联苯 (PBB)、多溴联苯醚 (PBDE) 等环境物质含量符合日本 SONY-SS-00259 和欧盟 RoHS2.0 (2011/65/EC) 指令环保要求。其主要成份如下：

原料名称			使用目的	含量	供应商	CAS.NO.
中文	英文	分子式				
乙烯-醋酸乙 烯共聚物	Ethylene-vinyl acetate copolymer	(CH ₂ -CH ₂) m-(CH ₂ -CH-C OOCH ₃) _n	主剂	50%	北京有机	24937-78-8
氢氧化镁	Magnesium Hydroxide	Mg(OH) ₂	阻燃剂	35%	锦昊辉	1309-42-8
磷系阻燃剂	Phosphorus	P	阻燃剂	10%	上海海以	7723-14-0
色母粒	Pigment	色母+填充剂	着色剂	5%	华万彩	——
油墨	Printing Ink	——	印字	——	信华	——

深圳市沃尔核材股份有限公司
二零一四年五月二十五日

品质中心

深圳市沃尔核材股份有限公司

物 质 安 全 资 料 表

MATERIAL SAFETY DATA SHEET

一、化学品名称和制造商信息 Chemical Product & Company Information :

物品名称: 无卤环保热缩套管 Article: Halogen Free Heat Shrinkable Tubings.
规格型号: 全系列规格 Spec: All Spec.
制造商或供货商名称: 深圳市沃尔核材股份有限公司 Manufacture or supplier: ShenZhen Woer Heat—Shrinkable Material Co.,Ltd.
地址及电话: 深圳市坪山新区兰景北路沃尔工业园/深圳市南山区西丽新围沃尔大厦 Address: WOER BULIDING XINWEI INDUSTRY PARK XILI TOWN SHENZHEN CITY CHINA TEL: 86-755-28299167 FAX: 86-755-28299164

二、化学组成信息 Composition/Information on Ingredients :

原料名称 Raw Material Name			使用目的 Using aim	含量 Content	供应商 Manufacturer	CAS. NO.
中文	英文 English Name	分子式				
乙烯-醋酸乙 烯共聚物	Ethylene-viny l acetate copolymer	(CH ₂ -CH ₂) m-(CH ₂ -CH-COO CH ₃) _n	主剂 Main Material	50%	北京有机 China Sinopec	24937-78-8
氢氧化镁	Magnesium Hydroxide	Mg(OH) ₂	阻燃剂 Flame-Retard ant Material	35%	锦昊辉 Jinhaohui Material Co.,Ltd.	1309-42-8
磷系阻燃剂	Phosphorus	P	阻燃剂 Flame-Retard ant Material	10%	上海海以 Shanghai Haiyi Co.,Ltd	7723-14-0
色母粒	Pigment	色母+填充剂	着色剂 Colorant Material	5%	华万彩 Huawangcai Co.,Ltd	—
油墨	Printing Ink	—	印字 Printint ink	—	信华 Xinhua Co.,Ltd	—

三、危害信息 Hazards Identification :

深圳市沃尔核材股份有限公司

最重要的危害项目 KEY HAZARD ITEM	健康危害效应：点燃后在短时间内会熄灭，有少量烟雾产生，对人体呼吸道产生轻微伤害。Health hazard note: Be fired for a moment and will be flameout, it will produce a little smoke, the smoke will hazard breath a little.
	环境影响：危害空气。 Environment hazard note: If be fired and pollute the air.
	物理性及化学性危害：常态是管状，在 70-125℃ 预热收缩。 Physics and chemistry characteristic: it normal is pipe and will shrink at 70-125℃, that perhaps is harmful.
	特殊危害：如果火烤、烟熏，烟雾会冲击眼睛、呼吸系统，对人体产生伤害。 Specific hazard: if be fired or sootiness, it will produce smoke and hurt eyes breath.
主要症状：眼睛流泪，喷嚏，咳嗽，在呼吸新鲜空气会减轻相应症状。 Mostly symptom: lachrymation , sneeze ,cough. It will be good after breathing fresh air.	
物品燃烧危险：点燃时会短时间燃烧。 Fireproofing characteristic: It flames out for a moment after leaving fire.	

四、急救措施 First Aid Measures :

不同暴露途径之急救方法：First-aid measures: 吸入：在正常操作下没有吸入的危险。 Normal it is not harmful for breath. 皮肤接触：正常接触时对皮肤无损伤。由于此管易划伤，建议操作时戴手套。 Skin touch: Normal it is not harmful for skin 眼睛接触：无影响 Normal it is not harmful for eyes. 食入：不能食用。 It can' t be eated..
最重要及危害效应：吸入燃烧烟雾，冲击呼吸系统。 Key symptom: Be fired ,the smoke choke the breath.
对急救人员之防护：配戴呼吸防护装置。 First aid defend: Get on gas mask
对医师之提示：对呼吸系统严重症者，应不断吸入新鲜空气来减轻症状。 Doctor suggest: If breath a lot of smoke ,must breath more fresh air , it can help you to reduce the symptom.

五、消防措施 Fire Fighting Measures:

适用灭火剂：不能长时间燃烧，使用粉末灭火器。 Fire-fighting material medical: Dust farina powder .
灭火时可能遭遇之特殊危害：燃烧可产生少量烟雾，冲击人体呼吸系统。 During fire-fighting, special hazard: Be fired ,produce a little smoke , and it can choke the breath.
特殊灭火程序：无。 Special fire-fighting program: No special program.
消防人员之特殊防护设备：正常消防设备。 Fire-fighter special dependence: Normal fire-fighting device.

六、泄露应急处理 Accidental Release Measures :

个人应注意事项：无 Person notice: No
环境注意事项：无 Environment notice: No

深圳市沃尔核材股份有限公司

清理方法：无 Cleaning method: No special method

七、操作和储存 Handling and Storage:

操作：用烘箱和热风枪加热即可收缩。
 Handling: Using oven or heating gun and it will shrink.

储存：常温下用纸箱包装好放置在凉荫处。
 Deposit: At normal temperature paper box package, no sun straight shine.

八、接触控制和个人防护措施 Exposure Controls/Personal Protection:

接触控制：无危害 Exposure Controls: No danger.

个人防护措施：无 Dependence: No

九：理化特性 Physical and Chemical Properties :

ITEM		TESTING METHOD	REQUIREMENT	
Physical	Tensile strength /MPa	GB/T 1040	≥10.4	
	Elongation/%	GB/T 1040	≥200	
	Ensil strength after aging/MPa	UL224; 158℃×168h	≥7.3	
	Elongation after aging/%	UL 224; 158℃×168h	≥100	
	Cold Blend	UL 224; -30℃×1h	No cracking	
Electrical	Dielectric Withstand	300V	UL224	No Breakdown for 1500V
		600V	UL224	No Breakdown for 2500V
	Dielectric Strength KV/mm		GB/T1408	≥15
	Volume resistance /Ω•cm		GB/T1410	≥1×10 ¹⁴
Chemical	Anti Corrosion		UL 224; 158℃×168h	PASS
	Copper stability		UL 224; 158℃×168h	PASS
	Flammability		UL224	☆

注：☆表示黄色和白色阻燃性能要特别说明，其他颜色阻燃性能能够达到要求。

Note: yellow and white flame retardant performance needs to be improved, the other can reach the required color flame retardant properties

十、稳定性和反应活性 Stability and Reactivity :

稳定性：不能分解。Stability: No decompose

特殊状况下可能之危害反应：有火的话，此种产品会短时间燃烧，产生烟雾。
 Special condition, perhaps hazard: If has fire, the production can be fired for a moment and produce a little smoke.

应避免之状况：高温放置会收缩。
 Please avoid the condition: At heat temperature condition the production will shrink.

应避免之物质：火种 Please avoid the condition: Fire.

危害分解物：烟雾。 Hazard decompose material: Smoke.

十一、毒理学信息 Toxicological Information:

深圳市沃尔核材股份有限公司

急毒性: 无 Rapid virulence: No
局部效应: 无 Part effect: No
致敏感性: 无 Cause hypersusceptibility : No
慢毒性或长期毒性: 无 Slowly or long-term virulence: No
特殊效应: 无 Special effect: No

十二、生态学信息 Ecological Information:

可能之环境影响/环境流: 该产品不会在自然界分解, 对动植物及水生物不会产生危害。Perhaps environment effect: The production can't decompose at nature condition, so it can't hazard the animal and plant.

十三、废弃处置 Disposal Considerations:

废弃处置方法: 这些物品将统一收集给废品收购站, 作相应环保处理。 Trash disposal: Collect and treat for the environment.

十四、运输信息 Transport Information:

国际运送规定: 无 World wild transportation rule: No
联合国编号: 无 U.N. code: No
国内运送规定: 无 Transportation in china rule: No
特殊运送方法及注意事项: 避免挤压变形, 利器损伤。 Special transportation method and notice: Avoid extrusion distortion, edge tool hurt.

十五、法规信息 Regulatory Information:

适用法规: UL224 Comply rule or law: UL224

十六、其他信息 Other Information:

参考文献: CTI/ITS/SGS检测报告 Reference : CTI/ITS/SGS Test Report
製表單位名稱: 深圳市沃尔核材股份有限公司
地址: 深圳市坪山新区兰景北路沃尔工业园 電話: 0755-28299167
製表人: 范松林 Tabulation: Songlin Fan
製表日期: 2017年03月07日 Date the MSDS Was prepared: Mar 07 2017
備註: 无

(以上内容如有歧义以中文为准 If the Chinese and English content are different, the Chinese content is right)



NOTICE OF AUTHORIZATION TO APPLY THE UL MARK

2007-09-18

Mr. Shaodun He
SHENZHEN WOER HEAT-SHRINKABLE MATERIAL CO LTD
Xinwei Industrial Park, Woer Mansion
Nanshan District, Xili
Shenzhen, Guangdong 518052
China

E-mail: sfshsd@163.com

Reference: File E203950 Project 07SC04243 P.O. Number HE, SHAODUN
USR/CNR - Evaluation of Currently Recognized Heat Shrinkable Flexible Cross-linked
Product: Polyolefin Tubing Cat. No. RSFR-H, rated 125C, 600V, VW-1, in all colors except clear, in 0.35
mm to 75.0 mm recovered ID, with modified compound.

Dear Mr. He,

Any information and documentation involving UL Mark services are provided on behalf of Underwriters Laboratories Inc. (UL) or any authorized licensee of UL.

UL's investigation of your product has been completed under the above project number and the subject product was determined to comply with the applicable requirements.

This letter temporarily supplements the UL Follow-Up Services Procedure and serves as authorization to apply the UL Recognized Marking and/or Recognized Component Mark only at the factory under UL's Follow-Up Service Program to the subject product, which is constructed as described below:

Identical to the subject model, which was submitted to UL for this investigation. The UL Records covering the product will be in the Follow-Up Services Procedure, File E203950, Volume 2. See attachment – 5 pages.

This authorization applies only to the address on this letter.

This authorization is effective from the date of this Notice and only for products at the indicated manufacturing locations. Records in the Follow-Up Services Procedure covering the product are now being prepared and will be sent to the indicated manufacturing locations in the near future. Please note that Follow-Up Services Procedures are sent to the manufacturers only unless the Applicant specifically requests this document.

Products that bear the UL Mark shall be identical to those that were evaluated by UL and found to comply with UL's requirements. If changes in construction are discovered, appropriate action will be taken for products not in conformance with UL's requirements and continued use of the UL Mark may be withdrawn.

Sincerely,

Audrey Woo
Project Engineer
Department: 3015TSCL
Tel: 408-754-6507
Fax: 408-689-6507
E-mail: audrey.woo@us.ul.com

Reviewed by:

JaneAnn P Matulich
Lead Engineering Associate
Department: 3015TSCL
E-mail: janeann.p.matulich@us.ul.com



DESCRIPTION

PRODUCT COVERED:

USR, CNR: Component - Extruded Electrical Tubing, Heat-Shrinkable Polyolefin Tubing, are Recognized with the following ratings:

Cat. No.	Colors	Recovered ID, mm	Temp. Rating, Deg. C	Voltage Rating, V	Flame Rating
RSFR-x	Black	1.0 - 4.0	125	600	VW-1
RSFR-x	White	0.5 - 25.0	125	600	VW-1
WKZM-x-yz	White	0.5 - 25.0	125	600	All Tubing
RSFR-H	All except Clear	0.35 - 75.0	125	600	VW-1

Note: for RSFR-x only, Black color tubing - x represents expanded ID of 2 mm - 8 mm. For White color tubing - x represents expanded ID of 1 mm - 50 mm.

Note: for WKZM-x-yz only, - x represents expanded ID of 1 mm - 50 mm and - yz represents any alpha and/or numeric combination for internal Client code.

USR: United States Standard Recognized.

CNR: Canadian National Standard Recognized.

GENERAL:

The tubing contained in this Report is constructed in accordance with the Bi-National Standard for Extruded Insulating Tubing, UL 224, Fifth Edition, and with the Canadian Standard for Insulating Tubing, CSA 22.2, No. 198.1, Second Edition.

MARKING:

Full Recognized company name, or File Number "E203950", catalog number, voltage rating, temperature rating in degrees C, inside diameter (before and after recovery) and date of manufacture shall be marked on tags attached to both ends of the tubing, on the shipping spool label, or on the smallest unit container.

The tag markings shall include the Recognized Component Mark for Canada, , in order to be considered UL Canadian Certified.

OPTIONAL MARKING:

- * Cat. Nos. **RSFR-H** and RSFR-x may be marked "VW-1".
- Cat. No. WKZM-x-yz: None

CONSTRUCTION DETAILS:

The tubing shall conform to the appropriate wall thickness and dimension table in UL 224 and to the following:

Cat. No.	Recovered ID, mm	Color	Material	Composition Formulation @
RSFR-x	1.0 - 4.0	Black	Polyolefin	Beijing Chemical EVA (14-2) 100%
RSFR-x	0.5 - 25.0	White	Polyolefin	Beijing Chemical EVA (14-2)100%
WKZM-x-yz	0.5 - 25.0#	White	Polyolefin	Beijing Chemical EVA (14-2) 50% with Huiyuan ChemicalCo., Ltd. KY-405 50%
RSFR-H	0.35 - 75.0	All except Clear	Polyolefin	See Table I

@ - The tubing formula consists only of the materials stated in the table. No other materials are added such as plasticizers, anti-oxygen agents, etc., unless specified in the formula above.

Note: for RSFR-x only, Black color tubing - x represents expanded ID of 2 mm - 8 mm. For White color tubing - x represents expanded ID of 1 mm - 50 mm.

Note: for WKZM-x-yz only, - x represents expanded ID of 1 mm - 50 mm and - yz represents any alpha and/or numeric combination for internal Client code.

- the minimum recovered wall thickness is limited to 0.70 mm for the minimum expanded inner diameter size of 1.0 to 16.0 mm.

Maximum Expansion Ratio:

Cat. No. RSFR-x may be expanded up to a maximum of 155% of its original extruded diameter.

Cat. No. WKZM-x-yz may be expanded up to a maximum of 176% of its original extruded diameter.

Cat. No. RSFR-H may be expanded up to a maximum of **335%** of its original extruded diameter.



台湾塑胶工业股份有限公司
FORMOSA PLASTICS CORPORATION

4F,201,TUNG HWA NORTH ROAD,TAIPEI TAIWAN
SALES DEPARTMENT,PLASTICS DIVIAION
TEL:886-2-27122211EXT 7193 FAX: 886-2-27137012

Certificate of Compliance

物性测定结果

判断结果：一级合格

品名	LOT NO	项目	检测方法	检测值
POM FM090	68WA1	出货日期 2016/12/20		
		Melt index(g/10min)	ASTM D1238	9.0
		熔融指数		
		Density(g/cm ³)	ASTM D792	1.41
		密度		
		Heat Deflection Temperature (°C)	ASTM D648	110.0
		热变形温度		
		Softening point temperature(°C)	ASTM D1525	162.0
		软化点温度		
		Tensile strength Yield (MPa)	ASTM D638	50.8
		降伏点拉力强度		
		Tensile elongation at break (%)	ASTM D638	60.0
		断裂点伸长率		
		Rockwell hardness (R scalr)	ASTM D785	80
		洛氏硬度		
		Flexural modulus (MPa)	ASTM D790	2550
		刚性系数		
		IZOD Impact strength(J/m)	ASTM D256	64.0
		IZOD 冲击强度		
		Mold Shrinkage (%)	ASTM D955	1.80
		收缩率		

FORMOSA PLASTICS CORP.
台湾塑胶工业股份有限公司



Tchi

物質安全資料表

序號：731

第1頁/3頁

一、物品與廠商資料

物品名稱：聚縮醛(POLYOXYMETHYLENE)
物品編號：-
製造商或供應商名稱、地址及電話：台灣塑膠工業股份有限公司聚縮醛廠 嘉義縣新港鄉中洋村中洋工業區3號
緊急聯絡電話/傳真電話：黃至誠 (05)3772111 轉 123 / (05)377-0312

二、成分辨識資料

中英文名稱：聚縮醛(POLYOXYMETHYLENE)
同義名稱：POLYACETAL、ACETAL RESIN
化學文摘社登記號碼(CAS NO.)：24969-26-4
危害物質成分(成分百分比)：100

三、危害辨識資料

最 重 要 危 害 與 效 應	健康危害效應：吸入：可造成鼻及咽喉發炎，支氣管肺炎。 皮膚：頻繁接觸造成皮膚變硬，變黑，皮膚炎及過敏。 眼睛：其液體會造成嚴重的灼傷。 食入：造成口，咽及胃嚴重的刺激及灼傷及發炎，並會造成嚴重的腹痛，隨之失去意識。 對大鼠實驗，具致癌性。
	環境影響：-
	物理性及化學性危害：-
	特殊危害：-
主要症狀：經熱融後之聚縮醛 如有甲醛蒸氣產生會有嚴重刺激性，並造成皮膚灼傷。	
物品危害分類：4(易燃固體)	

四、急救措施

吸 入：1. 將患者移至新鮮空氣處。 2. 若無呼吸，即施予人工呼吸或心肺甦術。 3. 立即送醫。	
皮膚接觸：1. 脫去髒衣物。 2. 儘速以大量清水沖洗十五分鐘。 3. 立即送醫。	
眼睛接觸：1. 立即用大量清水沖洗，並不時打開上下眼皮。 2. 立即就醫。	
食 入：1. 勿催吐。 2. 給予患者 500~800ml 之水，以稀釋胃中物質。 3. 自然嘔吐後，反復給予喝水，送醫。	
最重要症狀及危害效應概要：-	
對急救人員之防護：-	
對醫師之提示：-	

五、滅火措施

適用滅火劑：化學乾粉、二氧化碳、泡沫。
滅火時可能遭遇之特殊危害：-
特殊滅火程序：1. 噴水冷卻暴露於火場之物質表面，並保護救災人員。 2. 在安全許可下，遮斷火場之燃料源。 3. 若外洩物還未著火，使用噴水以分散蒸氣。 4. 允許火災在控制下，繼續燃燒或者使用泡沫或化學乾粉滅火。 5. 室內火災或室外大型火災，應配自攜式呼吸器。
消防人員之特殊防護裝備：-

物質安全資料表

序號：731

第2頁/3 頁

六、洩漏處理方法

個人應注意事項：作業人員應著適當防護具。

環境注意事項：-

清理方法：-

七、安全處置與儲存方法

處置：焚化或安全掩埋。

儲存：1. 儲存容器應加以標識滿，不用時容器應加以密閉。
2. 容器應避免衝擊等物理傷害。
3. 儲存於陰涼，乾燥，通風良好之地方，遠離作業場所。
4. 遠離熱源，火花及火星。
5. 避免陽光直接照射。
6. 最好分開置於空曠處儲存。

八、暴露預防措施

工程控制：-

控制參數

八小時日時量平均 容許濃度 TWA	短時間時量平均 容許濃度 STEL	最高容許 濃度 CEILING	生物指標 BEIS
-	-	-	-

個人防護設備：眼部：化學安全護目鏡。
呼吸：有機濾毒罐呼吸防護器；自攜式呼吸器。
手套：防塵手套。
皮膚：圍裙、工作靴。

衛生措施：作業人員應依規定著適當防護具。作業場所不得吸煙及飲食。

九、物理及化學性質

物質狀態：粒狀物	形狀：固體
顏色：乳白色	氣味：無
PH 值：-	沸點/沸點範圍：-
分解溫度：>460°F(238°C)	閃火點：- 測試方法：-
自燃溫度：-	爆炸界限：NOT TESTED
蒸氣壓：-	蒸氣密度：-
密度：-	溶解度：0.2-0.25% (24HR immersion at 25°C)

十、安定性及反應性

安定性：正常狀況下安定。

特殊狀況下可能之危害反應：32-2 項健康危害效應。

應避免之狀況：避免與火源接觸。

應避免之物質：強氧化劑、強酸。

危害分解物：燃燒分解物為一氧化碳、二氧化碳。

物質安全資料表

序號：731

第3頁/3 頁

十一、毒性資料

急毒性：-
局部效應：-
致敏感性：-
慢毒性或長期毒性：-
特殊效應：-

十二、生態資料

可能之環境影響/環境流佈：-

十三、廢棄處置方法

廢棄處置方法：1.化學焚化。2.掩埋。

十四、運送資料

國際運送規定：-
聯合國編號：-
國內運輸規定：-
特殊運送方法及注意事項：-

十五、法規資料

適用法規：-

十六、其他資料

參考文獻	-
製表者單位	名稱：台灣塑膠工業股份有限公司 POM 廠 地址/電話：嘉義縣新港鄉中洋村中洋工業區 3 號 (05)377-2111#123
製表人	職稱：工安 姓名(簽章)：黃至誠
製表日期	100 年 11 月 09 日
備註	

iq.ul.com

Component - Plastics [\[guide info\]](#)

E173318

FORMOSA PLASTICS CORP

HSIN KANG POM PLANT, 3 CHUNG YANG INDUSTRIAL PARK, HSIN KANG HSIANG, CHIA-YI 616 TW

FM025, FM090, FM090LV, FM090LMD, FM090UV, FM270

Acetal Polyoxymethylene (POM), furnished as pellets

Color	Min Thk	Flame	HWI	HAI	RTI		RTI Str
	(mm)	Class			Elec	Imp	
ALL	0.8	HB	5	0	110	90	90
	3.0	HB	3	0	110	90	100

Comparative Tracking Index (CTI): 0

Inclined Plane Tracking (IPT): -

Dielectric Strength (kV/mm): -

Volume Resistivity (10^X ohm-cm): -

High-Voltage Arc Tracking Rate (HVTR): 0

High Volt, Low Current Arc Resis (D495): 5

Dimensional Stability (%): -

ANSI/UL 94 small-scale test data does not pertain to building materials, furnishings and related contents. ANSI/UL 94 small-scale test data is intended solely for determining the flammability of plastic materials used in the components and parts of end-product devices and appliances, where the acceptability of the combination is determined by UL.

Report Date: 1999-01-18

Last Revised: 2016-06-20

© 2016 UL LLC

**IEC and ISO Test Methods**

Test Name	Test Method	Units	Thk (mm)	Value
Flammability	IEC 60695-11-10	Class (color)	0.8	HB75 (ALL)
			3.0	HB40 (ALL)
Glow-Wire Flammability (GWFI)	IEC 60695-2-12	C	-	-
Glow-Wire Ignition (GWIT)	IEC 60695-2-13	C	-	-
IEC Comparative Tracking Index	IEC 60112	Volts (Max)	-	-
IEC Ball Pressure	IEC 60695-10-2	C	-	-
ISO Heat Deflection (1.80 MPa)	ISO 75-2	C	-	-
ISO Tensile Strength	ISO 527-2	MPa	-	-
ISO Flexural Strength	ISO 178	MPa	-	-
ISO Tensile Impact	ISO 8256	kJ/m ²	-	-
ISO Izod Impact	ISO 180	kJ/m ²	-	-
ISO Charpy Impact	ISO 179-2	kJ/m ²	-	-

新 光 合 成 纖 維 股 份 有 限 公 司
中 壩 廠
臺 灣

8th Fl., 123, Sec.2, Nanking East Road, Taipei, Taiwan
Tel: 886-2-2507-0131 886-2-2507-1251(30Lines) 886-3-4932131
Fax:886-2-2506-8047 886-3-491-5763

產 品 材 質 證 明

新 耐 特 (SHINITE) PC/PBT

規 格 (GRADE) : A724

新耐特 (SHINITE) PC/PBT 為新光合成纖維股份有限公司，所產製的工程塑膠系列之一，經由混練程序製得。具有優越的機械性、高剛性、尺寸安定性、耐熱老化性和化學性質。

此外新耐特 (SHINITE) PC/PBT A724

製品 組成如下：

組成 CHEMICAL NAME	GRADE 規 格	A724
polycarbonate (PC) 樹脂 CAS NO: 25971-63-5		40%~80%
Polybutylene Terephthalate (PBT) 樹脂 CAS NO: 26062-94-2		20%~60%
Additives 添加劑 CAS NO: N.A.		1%~10%

GREEN PRODUCT (無毒材料) 符合 RoHS 、REACH(SVHC)

如有任何的問題及意見，歡迎撥空指教，謝謝。



送出日期:October 13, 2011



Material Safety Data Sheet

Product Name: SHINBLEND® ALLOY A724
Revision Number: 4
Version Date: 2010/2/16

Page:1/3

1. Chemical, Product and Company Identification	
PRODUCT	SHINBLEND® ALLOY A724
COMPANY	Shinkong Synthetic Fibers Corporation, Engineering Plastic Division, 8F, 123, Sec. 2, Nanking East Road, Taipei, Taiwan
PHONE	886-2-2507-1251, 886-3-493-2131
FAX	886-2-2506-8047, 886-3-491-5763
2. Composition/ Information on Ingredients	
Chemical Characterization : Blends of polycarbonate(CAS#25971-63-5) and Polybutylene Terephthalate (PBT, CAS# 30965-26-5)	
3. Hazards Identification	
Hazardous Decomposition Products : Processing fumes evolved at recommended processing conditions contain trace levels of carbon monoxide, carbon dioxide ,aromatic and aliphatic hydrocarbons.	
4. First Aid Measures	
If molten polymer contacts the skin or eyes, cool rapidly with cold water. DO NOT use solvent for removal. DO NOT attempt to remove the polymer from the skin! Obtain IMMEDIATE medical attention.	
5. Fire Fighting Measures	
Suitable - water spray and foam. Water is the best. Approved pressure demand breathing apparatus and protective clothing should be used for all fires.	
6. Accidental release measures	
Sweep up and dispose in proper containers to prevent slipping hazards.	



Material Safety Data Sheet

Product Name: SHINBLEND® ALLOY A724
Revision Number: 4
Version Date: 2010/2/16

Page:3/3

11. Toxicological information

Product not considered primary eye and skin irritant.

TOXIC : N/A

12. Ecological information

We recommend this material be disposed of by properly scrubbed incineration or recycling

Not expected to present any significant ecological problems.

13. Disposal considerations

Product is not a RCRA hazardous waste. Recycling is encouraged. Dispose of using good manufacturing practices under local regulations for your area.

14. Transport information

GGVSEE/IMDG Code :

UN No. : None

ICAO/IATA-DGR : Not Regulated

GGVE/GGVS :

RID/ADR :

ADNR :

DOT Hazard Class : Not Regulated

Proper Shipping Name : Not Regulated

Identification Number : Not Listed

TDGA : Not Listed

15. Regulatory Information

TSCA Status : This product complies with Chemical Substance Inventory requirements of the US EPA Toxic Substances Control Act (TSCA).

WHMIS Classification : Not a controlled product.

16. Other information

SHINITE is a registered trademark of the SHINKONG SYNTHETIC FIBERS CO.

Component - Plastics

E107536

Guide Information

SHINKONG SYNTHETIC FIBERS CORP

223 YEN PING RD SEC 3, PIN CHENG TAOYUAN HSIEN 324 TW

A724

Polybutylene Terephthalate/Polycarbonate (PBT/PC), furnished as pellets

<u>Color</u>	<u>Min. Thk</u> <u>(mm)</u>	<u>Flame</u> <u>Class</u>	<u>HWI</u>	<u>HAI</u>	<u>RTI</u> <u>Elec</u>	<u>RTI</u> <u>Imp</u>	<u>RTI</u> <u>Str</u>
NC	0.8	HB	4	1	75	75	75
	1.6	HB	4	1	75	75	75
	3.2	HB	2	1	75	75	75

Comparative Tracking Index (CTI): -
Dielectric Strength (kV/mm): 38
High-Voltage Arc Tracking Rate (HVTR): 2
Dimensional Stability (%): -

Inclined Plane Tracking (IPT) kV: -
Volume Resistivity (10^x ohm-cm): 17
High Volt, Low Current Arc Resis (D495): -

ANSI/UL 94 small-scale test data does not pertain to building materials, furnishings and related contents. ANSI/UL 94 small-scale test data is intended solely for determining the flammability of plastic materials used in the components and parts of end-product devices and appliances, where the acceptability of the combination is determined by UL.

Report Date: 1992-04-06

Last Revised: 2005-09-21

© 2018 UL LLC

**IEC and ISO Test Methods**

Test Name	Test Method	Units	Thk (mm)	Value
Flammability	IEC 60695-11-10	Class (color)	0.8	HB75 (NC)
			1.6	HB75 (NC)
			3.2	HB40 (NC)
Glow-Wire Flammability (GWFI)	IEC 60695-2-12	°C	-	-
Glow-Wire Ignition (GWIT)	IEC 60695-2-13	°C	-	-
IEC Comparative Tracking Index	IEC 60112	Volts (Max)	-	-
IEC Ball Pressure	IEC 60695-10-2	°C	-	-
ISO Heat Deflection (1.80 MPa)	ISO 75-2	°C	-	-
ISO Tensile Strength	ISO 527-2	MPa	-	-
ISO Flexural Strength	ISO 178	MPa	-	-
ISO Tensile Impact	ISO 8256	kJ/m ²	-	-
ISO Izod Impact	ISO 180	kJ/m ²	-	-
ISO Charpy Impact	ISO 179-2	kJ/m ²	-	-

物性检测报告

Physical Test Report

产品型号: TPE 100A
Product Type

客户:

说

明:

序号 NO	检测项目 Test Item	检测内容 Test Content	检测方法 Test method	单位 Unit	检测结果 Result
1	物理性能 Physical properties	硬度 Hardness	ASTM D-2240	<input checked="" type="checkbox"/> ShoreA <input type="checkbox"/> ShoreC <input type="checkbox"/> ShoreD	98
		比重 Specific Gravity	ASTM D-792	g/cm3	1.02
		拉伸强度 Tensile Strength	ASTM D-412	kgf/cm2	147
		最大延伸率 Ultimate Elongation	ASTM D-412	%	390
		撕裂强度 Tear Strength	ASTM D-624	kgf/cm	67
		300%定伸 300%elongation	ASTM D-412	kgf/cm2	89
		颜色 (目测)			
2	备注 Remark				
3	加工参考意见: Manufacture of Reference comments 参考温度: 165-210°C.				

物质安全资料表

1. 化學品及廠商資料

化學品名稱	TPE 100A
建議用途及限制使用	注塑加工
製造者	东莞市宇邦塑胶有限公司
地址	东莞市樟木头镇塑胶原料市场三期B61号
電話	0769-87126360
傳真電話	0769-87126361

2. 危害性分類

物品危害分類	無(不屬於 GHS 27 種危害分類)
標示內容	無(不屬於 GHS 27 種危害分類)
其他危害	眼睛:細粉或加工過程發煙, 進入眼睛可能對眼睛造成刺激。 皮膚:加工過程高溫熔融狀態, 若接觸皮膚可能引起皮膚燙傷。 吸入:細粉或加工過程發煙, 進入呼吸道可能對呼吸道造成刺激。 食入:若誤食, 建議就醫取出。

3. 成分辨識資料

化學名稱	Styrene- Butadiene Copolymer	Mineral Oil	Additives
含量	>72.5 %	≤ 28.5%	≤ 2 %
化學式	(C ₈ H ₈ . C ₅ H ₈ O ₂ . C ₄ H ₄) x	-	-
CAS No.	9003-55-8	64742-54-7	Proprietary
危害性不純物	無		

4. 急救措施

不同暴露途徑之急救方

式:

吸入

若吸入熔融樹脂逸出之氣體, 將患者移至通風處, 立即送醫。

皮膚接觸

若接觸到橡膠粒或橡膠粉末, 以清水沖洗。

若接觸到熔膠, 以大量(肥皂)水沖洗患部及衣物, 立即送醫。

眼睛接觸

若接觸到橡膠粒或橡膠粉末, 以大量清水至少沖洗 15 分鐘。若有不適, 立即送醫。

若接觸到高溫熔融樹脂逸出之氣體, 以大量清水至少沖洗 15 分鐘。若有不適, 立即送醫。

食入

催吐, 以清水漱口, 若有不適, 立即送醫。

最重要症狀及危害效應

未經加工時, 無危害。加工時, 燙傷危害。

對醫師之提示

無需特殊解毒劑，是病患之症狀給予支持性療法。

5. 消防措施

適用滅火劑	水、泡沫、乾粉
滅火時可能遭遇之特殊危害	無
特殊滅火程序	移除可燃物
消防人員設備	使用供氧式呼吸防護具

6. 洩漏處理方法

個人應注意事項	若塑膠粒或塑膠粉末殘留於地面上，可能會導致人員滑倒。
環境注意事項	為防止鳥類或魚類由排水系統中攝食，須徹底回收
清理方法	回收或廢棄

7. 安全處置與儲存方法

處置	操作處所須嚴禁煙火，做好整理整頓以避免粉塵累積。為防止塵爆，空氣輸送管路、袋濾器及儲槽須加裝靜電消除裝置，並確實接地。袋濾器之濾材採導電性材質。
儲存	存放於陰涼處所，避免直射陽光、雨淋及急遽之溫差。儲存處嚴禁煙火

8. 暴露預防措施

控制參數：
容許濃度(TLV) 可吸入粉塵濃度 5mg/m³，全天濃度不超過 10mg/m³ 為上限。
個人防護設備：
呼吸防護 清洗成型機時使用防毒面具。
手部防護 接觸熔膠時使用皮手套。
眼睛防護 平時使用安全眼鏡，清洗成型機時使用護目鏡
皮膚及身體防護 長袖作業服
衛生措施 身體接觸膠粒後，若殘留細粉，建議清洗。

9. 物理及化學性質

物質狀態	固態
形狀	粒狀
顏色	白色
氣味	無
熔點	無
PH 值	無
沸點	無

易燃性	低
閃火點	不適用
分解溫度	不適用
自燃溫度	不適用
爆炸界限	不適用
蒸氣壓	極微小可忽略不計
蒸氣密度	無(固體)
密度	0.92~0.95
溶解度	不溶於水
辛醇/水分配係數	無
嗅覺閾值	無

11. 毒性資料

暴露途徑	無毒害
症狀	無
急毒性	無
慢毒性或長期毒性	無
刺激性	分解後之橡膠所產生的煙及蒸氣會刺激眼睛

12. 生態資料

生態毒性	無生態毒性
持久性及降解性	水無法溶解，於環境周遭呈安定狀態殘存，於陽光長期照射後將呈現表層剝離狀態，目前不預期能經生化作用而分解。
生物蓄積性	不適用
土壤中之流動性	無法經生化作用分解，於陸上環境將殘存於土壤中。
其他不良效應	為防止被海洋生物或鳥類攝食，嚴禁丟棄至海洋或水域。

13. 廢棄物處理

廢棄處置方法：

適當之焚化爐燃燒或掩埋法。不適當之焚化爐可能會產生有毒氣體如 CO, HCN, AN 及 SM.

14. 運送資料

國際運送規定	避免弄潮或被草率處理，包裝不要受損。 若包裝受損，將造成膠粒灑出，容易有滑倒或摔倒情形發生，應盡速處理。
聯合國運輸名稱	不適用
運輸危害分類	不適用
包裝類別	不適用
海洋污染物	無
特殊運送方法及注意事項	無

15. 法規資料

適用法規	職業安全衛生法 職業安全衛生設施規則 勞工作業環境空氣中有害物容許濃度標準 道路交通安全規則 事業廢棄物貯存清除處理方法及設施標準
------	---

16. 其他資料

Component - Plastics

E83247

Guide Information

DONGGUAN YUBANG PLASTIC CO.,LD

1-1 NIHONBASHI-HONCHO 1-CHOME, CHUO-KU TOKYO 103-0023 JP

5526

Thermoplastic Elastomer (TPE), ester-ester "Hytrell", furnished as pellets

<u>Color</u>	<u>Min. Thk</u> <u>(mm)</u>	<u>Flame</u> <u>Class</u>	<u>HWI</u>	<u>HAI</u>	<u>RTI</u> <u>Elec</u>	<u>RTI</u> <u>Imp</u>	<u>RTI</u> <u>Str</u>
NC	1.5	HB	-	-	50	50	50

Comparative Tracking Index (CTI): -	Inclined Plane Tracking (IPT) kV: -
Dielectric Strength (kV/mm): -	Volume Resistivity (10 ^x ohm-cm): -
High-Voltage Arc Tracking Rate (HVTR): -	High Volt, Low Current Arc Resis (D495): -
Dimensional Stability (%): -	

ANSI/UL 94 small-scale test data does not pertain to building materials, furnishings and related contents. ANSI/UL 94 small-scale test data is intended solely for determining the flammability of plastic materials used in the components and parts of end-product devices and appliances, where the acceptability of the combination is determined by UL.

Report Date: 1986-06-26

Last Revised: 2003-10-24

© 2018 UL LLC

**IEC and ISO Test Methods**

Test Name	Test Method	Units	Thk (mm)	Value
Flammability	IEC 60695-11-10	Class (color)	1.5	HB75 (NC)
Glow-Wire Flammability (GWFI)	IEC 60695-2-12	°C	-	-
Glow-Wire Ignition (GWIT)	IEC 60695-2-13	°C	-	-
IEC Comparative Tracking Index	IEC 60112	Volts (Max)	-	-
IEC Ball Pressure	IEC 60695-10-2	°C	-	-
ISO Heat Deflection (1.80 MPa)	ISO 75-2	°C	-	-
ISO Tensile Strength	ISO 527-2	MPa	-	-
ISO Flexural Strength	ISO 178	MPa	-	-
ISO Tensile Impact	ISO 8256	kJ/m ²	-	-
ISO Izod Impact	ISO 180	kJ/m ²	-	-
ISO Charpy Impact	ISO 179-2	kJ/m ²	-	-