

TEST REPORT

CERTIFICATE OF CONFORMITY

Standard: 47 CFR FCC Part 15, Subpart E (Section 15.407)
Report No.: RFBARR-WTW-P23040352J-1
FCC ID: RAS-MT7925B22M
Product: 2TX 11be (WiFi7) BW160 + BT/BLE Combo Card
Brand: MediaTek
Model No.: MT7925B22M
Received Date: 2024/3/12
Test Date: 2024/5/7 ~ 2024/5/8
Issued Date: 2024/6/19

Applicant: MediaTek Inc.
Address: No. 1, Dusing 1st Rd., Hsinchu Science Park, Hsinchu City, 30078 Taiwan
Issued By: Bureau Veritas Consumer Products Services (H.K.) Ltd., Taoyuan Branch
Hsin Chu Laboratory
Lab Address: E-2, No.1, Li Hsin 1st Road, Hsinchu Science Park, Hsinchu City 300, Taiwan
Test Location: E-2, No.1, Li Hsin 1st Road, Hsinchu Science Park, Hsinchu City 300, Taiwan
FCC Registration / 723255 / TW2022
Designation Number:

Approved by: _____



, Date: _____

2024/6/19

Wen Yu / Assistant Manager

This test report consists of 150 pages in total. It may be duplicated completely for legal use with the approval of the applicant. It should not be reproduced except in full, without the written approval of our laboratory. The test results in the report only apply to the tested sample. The test results in this report are traceable to the national or international standards.



Prepared by : Claire Kuan / Specialist

This report is governed by, and incorporates by reference, the Conditions of Testing as posted at the date of issuance of this report at <http://www.bureauveritas.com/home/about-us/our-business/cps/about-us/terms-conditions/> and is intended for your exclusive use. Any copying or replication of this report to or for any other person or entity, or use of our name or trademark, is permitted only with our prior written permission. This report sets forth our findings solely with respect to the test samples identified herein. The results set forth in this report are not indicative or representative of the quality or characteristics of the lot from which a test sample was taken or any similar or identical product unless specifically and expressly noted. Our report includes all of the tests requested by you and the results thereof based upon the information that you provided to us. Measurement uncertainty is only provided upon request for accredited tests. Statements of conformity are based on simple acceptance criteria without taking measurement uncertainty into account, unless otherwise requested in writing. You have 60 days from date of issuance of this report to notify us of any material error or omission caused by our negligence or if you require measurement uncertainty; provided, however, that such notice shall be in writing and shall specifically address the issue you wish to raise. A failure to raise such issue within the prescribed time shall constitute your unqualified acceptance of the completeness of this report, the tests conducted and the correctness of the report contents.

Table of Contents

Release Control Record	3
1 Certificate.....	4
2 Summary of Test Results	5
2.1 Measurement Uncertainty	5
2.2 Supplementary Information	5
3 General Information	6
3.1 General Description of EUT	6
3.2 Antenna Description of EUT	8
3.3 Channel List.....	10
3.4 Test Mode Applicability and Tested Channel Detail.....	12
3.5 Duty Cycle of Test Signal.....	13
3.6 Test Program Used and Operation Descriptions	15
3.7 Connection Diagram of EUT and Peripheral Devices	15
3.8 Configuration of Peripheral Devices and Cable Connections	16
4 Test Instruments	17
4.1 AC Power Conducted Emissions	17
4.2 Unwanted Emissions below 1 GHz	18
4.3 Unwanted Emissions above 1 GHz.....	19
5 Limits of Test Items.....	20
5.1 AC Power Conducted Emissions	20
5.2 Unwanted Emissions below 1 GHz	20
5.3 Unwanted Emissions above 1 GHz.....	21
6 Test Arrangements.....	22
6.1 AC Power Conducted Emissions	22
6.1.1 Test Setup	22
6.1.2 Test Procedure.....	22
6.2 Unwanted Emissions below 1 GHz	23
6.2.1 Test Setup	23
6.2.2 Test Procedure.....	24
6.3 Unwanted Emissions above 1 GHz.....	25
6.3.1 Test Setup	25
6.3.2 Test Procedure.....	26
7 Test Results of Test Item	27
7.1 AC Power Conducted Emissions	27
7.2 Unwanted Emissions below 1 GHz	29
7.3 Unwanted Emissions above 1 GHz.....	33
8 Pictures of Test Arrangements	149
9 Information of the Testing Laboratories	150



Release Control Record

Issue No.	Description	Date Issued
RFBARR-WTW-P23040352J-1	Original release.	2024/6/19

1 Certificate

Product: 2TX 11be (WiFi7) BW160 + BT/BLE Combo Card

Brand: MediaTek

Test Model: MT7925B22M

Sample Status: Engineering sample

Applicant: MediaTek Inc.

Test Date: 2024/5/7 ~ 2024/5/8

Standard: 47 CFR FCC Part 15, Subpart E (Section 15.407)

Measurement ANSI C63.10-2013

procedure: KDB 789033 D02 General UNII Test Procedure New Rules v02r01

The above equipment has been tested by **Bureau Veritas Consumer Products Services (H.K.) Ltd., Taoyuan Branch**, and found compliance with the requirement of the above standards. The test record, data evaluation & Equipment Under Test (EUT) configurations represented herein are true and accurate accounts of the measurements of the sample's RF characteristics under the conditions specified in this report.

2 Summary of Test Results

47 CFR FCC Part 15, Subpart E (Section 15.407)			
Clause	Test Item	Result	Remark
15.407(a)(2)	26 dB Bandwidth	N/A	Refer to Note 1 below
15.407(a)(1) 15.407(a)(3)	RF Output Power	N/A	Refer to Note 1 below
15.407(e)	Power Spectral Density	N/A	Refer to Note 1 below
15.407(e)	6 dB Bandwidth	N/A	Refer to Note 1 below
---	Occupied Bandwidth	N/A	Refer to Note 1 below
15.407(g)	Frequency Stability	N/A	Refer to Note 1 below
15.407(b)(9)	AC Power Conducted Emissions	Pass	Minimum passing margin is -6.99 dB at 0.15781 MHz
15.407(b)(9)	Unwanted Emissions below 1 GHz	Pass	Minimum passing margin is -0.9 dB at 300.27 MHz
15.203	Unwanted Emissions above 1 GHz	Pass	Minimum passing margin is -0.17 dB at 5149.93 MHz
15.203	Antenna Requirement	Pass	Antenna connector is i-pex(MHF), R-SMA, RP SMA PLUG, IPEX not a standard connector.

Notes:

1. AC Power Conducted Emissions and Unwanted Emissions test items were performed for this addendum. The others testing data refer to original test report.
2. Determining compliance based on the results of the compliance measurement, not taking into account measurement instrumentation uncertainty.
3. The "Dynamic Frequency Selection measurement" was recorded in DFS test report.

2.1 Measurement Uncertainty

Where relevant, the following measurement uncertainty levels have been estimated for tests performed on the EUT as specified in CISPR 16-4-2:

Measurement	Specification	Expanded Uncertainty (k=2) (±)
AC Power Conducted Emissions	150 kHz ~ 30 MHz	1.9 dB
Unwanted Emissions below 1 GHz	9 kHz ~ 30 MHz	3.1 dB
	30 MHz ~ 1 GHz	5.5 dB
Unwanted Emissions above 1 GHz	1 GHz ~ 18 GHz	5.1 dB
	18 GHz ~ 40 GHz	5.3 dB

The other instruments specified are routine verified to remain within the calibrated levels, no measurement uncertainty is required to be calculated.

2.2 Supplementary Information

There is not any deviation from the test standards for the test method, and no modifications required for compliance.

3 General Information

3.1 General Description of EUT

Product	2TX 11be (WiFi7) BW160 + BT/BLE Combo Card
Brand	MediaTek
Test Model	MT7925B22M
Status of EUT	Engineering sample
Power Supply Rating	3.3 Vdc from host equipment
Modulation Type	64QAM, 16QAM, QPSK, BPSK for OFDM 256QAM for OFDM in 11ac mode 1024QAM for OFDMA in 11ax mode 4096QAM for OFDMA in 11be mode
Modulation Technology	OFDM, OFDMA
Transfer Rate	802.11a: up to 54 Mbps 802.11n: up to 300 Mbps 802.11ac: up to 1733.3 Mbps 802.11ax: up to 2401.9 Mbps 802.11be: up to 2882.4 Mbps
Operating Frequency	5.18 GHz ~ 5.24 GHz 5.25 GHz ~ 5.32 GHz 5.5 GHz ~ 5.72 GHz 5.745 GHz ~ 5.825 GHz
Number of Channel	802.11a, 802.11n (HT20), 802.11ac (VHT20), 802.11ax (HE20), 802.11be (EHT20): 25 802.11n (HT40), 802.11ac (VHT40), 802.11ax (HE40), 802.11be (EHT40): 12 802.11ac (VHT80), 802.11ax (HE80), 802.11be (EHT80): 6 802.11ac (VHT160), 802.11ax (HE160), 802.11be (EHT160): 2
Resource Unit (RU)	Single RU: 26-tone, 52-tone, 106-tone, 242-tone, 484-tone, 996-tone, 2 * 996-tone Multi-RU (Small RU): 52-tone + 26-tone, 106-tone + 26-tone Multi-RU (Large RU): 484-tone + 242-tone, 996-tone + 484-tone, 996-tone + 484-tone + 242-tone
Output Power	5.18 GHz ~ 5.25 GHz : 239.157 mW (23.79 dBm) 5.25 GHz ~ 5.32 GHz : 222.907 mW (23.48 dBm) 5.5 GHz ~ 5.72 GHz : 209.52 mW (23.21 dBm) 5.745 GHz ~ 5.825 GHz : 618.21 mW (27.91 dBm)

Note:

- This report is prepared for FCC Class II permissive change. The difference compared with the Report No.: RFBARR-WTW-P23040352-1 & RFBARR-WTW-P23040352I-1 design is as the following information:
 - ◆ Add Monopole Antenna (Refer to Section 3.2).
- According to above condition, only AC Power Conducted Emissions and Unwanted Emissions test items need to be performed. And all data were verified to meet the requirements.
- There are Bluetooth and WLAN (2.4 GHz & 5 GHz & 6 GHz) technology used for the EUT.
- Simultaneously transmission condition.

Condition	Technology	
1	WLAN (2.4 GHz) (1TX)	WLAN (5 GHz) (1TX)
2	WLAN (2.4 GHz) (1TX)	WLAN (5.9 GHz) (1TX)
3	WLAN (2.4 GHz) (1TX)	WLAN (6 GHz) (1TX)
4	WLAN (5 GHz) (1TX)	WLAN (6 GHz) (1TX)
5	WLAN (5 GHz) (2TX)	Bluetooth
6	WLAN (5.9 GHz) (2TX)	Bluetooth
7	WLAN (6GHz) (2TX)	Bluetooth

Note: The emission of the simultaneous operation has been evaluated and no non-compliance was found.

5. The EUT has below Sku numbers, which are identical to each other in all aspects except for the following table:

Sku No	Brand	Model	Different
Sku1	MediaTek	MT7925B22M	DVDDIO 3.3V, power from platform.
Sku2	MediaTek	MT7925B22M	DVDDIO 1.8V, power from IC PMU. (Power Management Unit).

6. The EUT support OFDMA and Partial RU mode, therefore partial RU combination were investigated and the worst case scenario was identified.

7. The EUT support MRU mode is listed as below.

BW	Small size		Large size		
	52+26-tone MRU	106+26-tone MRU	484+242-tone MRU	996+484-tone MRU	996+484+242-tone MRU
20 MHz	v	v	-	-	-
40 MHz	v	v	-	-	-
80 MHz	v	v	v	-	-
160 MHz	v	v	v	v	v

8. The above EUT information is declared by manufacturer and for more detailed features description, please refers to the manufacturer's specifications or user's manual.

3.2 Antenna Description of EUT

1. The antenna information is listed as below.

Original								
Antenna Set	RF Chain No.	Brand	Model	Antenna Net Gain (dBi)	Frequency Range (GHz)	Antenna Type	Connector Type	Cable Length (mm)
1	Chain0	PSA	RFMTA340718EMLB302	3.18 4.92	2.4~2.4835 5.15~5.895	PIFA	i-pex(MHF)	200
	Chain1	PSA	RFMTA340718EMLB302	3.18 4.92	2.4~2.4835 5.15~5.895	PIFA	i-pex(MHF)	200
2	Chain0	PSA	RFMTA311020EMMB301	1.71 4.82 4.76 4.29 4.61 4.09	2.4~2.4835 5.15~5.895 5.925~6.425 6.425~6.525 6.525~6.875 6.875~7.125	PIFA	i-pex(MHF)	200
	Chain1	PSA	RFMTA311020EMMB301	1.71 4.82 4.76 4.29 4.61 4.09	2.4~2.4835 5.15~5.895 5.925~6.425 6.425~6.525 6.525~6.875 6.875~7.125	PIFA	i-pex(MHF)	200
3	Chain0	PSA	RFMTA421230IMMB701	-13.92 -13.91 -13.91 -14.46	5.925~6.425 6.425~6.525 6.525~6.875 6.875~7.125	PIFA	i-pex(MHF)	300
	Chain1	PSA	RFMTA421230IMMB701	-13.92 -13.91 -13.91 -14.46	5.925~6.425 6.425~6.525 6.525~6.875 6.875~7.125	PIFA	i-pex(MHF)	300
4	Chain0	Cortec	AN2450-4902BRS	2.42 3.87	2.4~2.4835 5.15~5.895	Dipole	R-SMA	150
	Chain1	Cortec	AN2450-4902BRS	2.42 3.87	2.4~2.4835 5.15~5.895	Dipole	R-SMA	150
5	Chain0	VSO	JR2Q00340-1	1.62 3.2 3.93 3.61 3.61 3.14	2.4~2.4835 5.15~5.895 5.925~6.425 6.425~6.525 6.525~6.875 6.875~7.125	Dipole	RP SMA PLUG	40
	Chain1	VSO	JR2Q00340-1	1.62 3.2 3.93 3.61 3.61 3.14	2.4~2.4835 5.15~5.895 5.925~6.425 6.425~6.525 6.525~6.875 6.875~7.125	Dipole	RP SMA PLUG	40
6	Chain0	PSA	RFPCA460632IMMB701	-13.2 -13.67 -13.67 -13.09	5.925~6.425 6.425~6.525 6.525~6.875 6.875~7.125	Dipole	IPEX	320
	Chain1	PSA	RFPCA460632IMMB701	-13.2 -13.67 -13.67 -13.09	5.925~6.425 6.425~6.525 6.525~6.875 6.875~7.125	Dipole	IPEX	320

Newly								
Antenna Set	RF Chain No.	Brand	Model	Antenna Net Gain (dBi)	Frequency Range (GHz)	Antenna Type	Connector Type	Cable Length (mm)
7	Chain0	HongBo	260-25096	3.11	2.4~2.4835	Monopole	i-pex(MHF)	300
				4.88	5.15~5.895			
				4.91	5.25~5.35			
				4.9	5.47~5.725			
				4.9	5.725~5.85			
				4.87	5.85~5.895			
				4.73	5.925~6.425			
				4.29	6.425~6.525			
				4.58	6.525~6.875			
	4.09	6.875~7.125						
	Chain1	HongBo	260-25096	3.11	2.4~2.4835	Monopole	i-pex(MHF)	300
				4.88	5.15~5.895			
				4.91	5.25~5.35			
				4.9	5.47~5.725			
				4.9	5.725~5.85			
				4.87	5.85~5.895			
				4.73	5.925~6.425			
				4.29	6.425~6.525			
4.58				6.525~6.875				
4.09	6.875~7.125							

Note: For 1TX diversity configuration, transmit chain 0 and chain 1 have been evaluated, the chain 0 will be used as representative test.

* Detail antenna specification please refer to antenna datasheet and/or antenna measurement report.

2. The EUT incorporates a MIMO function:

5 GHz Band		
Modulation Mode	TX & RX Configuration	
802.11a	1TX (Diversity) / 2TX	2RX
802.11n (HT20)	1TX (Diversity) / 2TX	2RX
802.11n (HT40)	1TX (Diversity) / 2TX	2RX
802.11ac (VHT20)	1TX (Diversity) / 2TX	2RX
802.11ac (VHT40)	1TX (Diversity) / 2TX	2RX
802.11ac (VHT80)	1TX (Diversity) / 2TX	2RX
802.11ac (VHT160)	1TX (Diversity) / 2TX	2RX
802.11ax (HE20)	1TX (Diversity) / 2TX	2RX
802.11ax (HE40)	1TX (Diversity) / 2TX	2RX
802.11ax (HE80)	1TX (Diversity) / 2TX	2RX
802.11ax (HE160)	1TX (Diversity) / 2TX	2RX
802.11be (EHT20)	1TX (Diversity) / 2TX	2RX
802.11be (EHT40)	1TX (Diversity) / 2TX	2RX
802.11be (EHT80)	1TX (Diversity) / 2TX	2RX
802.11be (EHT160)	1TX (Diversity) / 2TX	2RX
802.11ax (RU26/52/106/242/484/996/996x2)	1TX (Diversity) / 2TX	2RX
802.11be (RU26/52/106/242/484/996/996x2 MRU52+26/106+26/ 484+242/996+484/996+484+242)	1TX (Diversity) / 2TX	2RX

Note: The modulation and bandwidth are similar for 802.11n mode for 20 MHz (40 MHz), 802.11ac mode for 20 MHz (40 MHz, 80 MHz, 160 MHz), 802.11ax mode for 20 MHz (40 MHz, 80 MHz, 160 MHz) and 802.11be mode for 20 MHz (40 MHz, 80 MHz, 160 MHz) therefore the manufacturer will control the power for 802.11n/ac/ax mode is same as the 802.11be mode or more lower than it and investigated worst case to representative mode in test report.

3.3 Channel List

FOR 5180 ~ 5240 MHz

4 channels are provided for 802.11a, 802.11n (HT20), 802.11ac (VHT20), 802.11ax (HE20), 802.11be (EHT20):

Channel	Frequency	Channel	Frequency
36	5180 MHz	44	5220 MHz
40	5200 MHz	48	5240 MHz

2 channels are provided for 802.11n (HT40), 802.11ac (VHT40), 802.11ax (HE40), 802.11be (EHT40):

Channel	Frequency	Channel	Frequency
38	5190 MHz	46	5230 MHz

1 channel is provided for 802.11ac (VHT80), 802.11ax (HE80), 802.11be (EHT80):

Channel	Frequency
42	5210 MHz

FOR 5250 ~ 5320 MHz

4 channels are provided for 802.11a, 802.11n (HT20), 802.11ac (VHT20), 802.11ax (HE20), 802.11be (EHT20):

Channel	Frequency	Channel	Frequency
52	5260 MHz	60	5300 MHz
56	5280 MHz	64	5320 MHz

2 channels are provided for 802.11n (HT40), 802.11ac (VHT40), 802.11ax (HE40), 802.11be (EHT40):

Channel	Frequency	Channel	Frequency
54	5270 MHz	62	5310 MHz

1 channel is provided for 802.11ac (VHT80), 802.11ax (HE80), 802.11be (EHT80):

Channel	Frequency
58	5290 MHz

1 straddle channel is provided for 802.11ac (VHT160), 802.11ax (HE160), 802.11be (EHT160):

Channel	Frequency
50	5250 MHz

FOR 5500 ~ 5720 MHz

12 channels are provided for 802.11a, 802.11n (HT20), 802.11ac (VHT20), 802.11ax (HE20), 802.11be (EHT20):

Channel	Frequency	Channel	Frequency
100	5500 MHz	124	5620 MHz
104	5520 MHz	128	5640 MHz
108	5540 MHz	132	5660 MHz
112	5560 MHz	136	5680 MHz
116	5580 MHz	140	5700 MHz
120	5600 MHz	144	5720 MHz

6 channels are provided for 802.11n (HT40), 802.11ac (VHT40), 802.11ax (HE40), 802.11be (EHT40):

Channel	Frequency	Channel	Frequency
102	5510 MHz	126	5630 MHz
110	5550 MHz	134	5670 MHz
118	5590 MHz	142	5710 MHz

3 channels are provided for 802.11ac (VHT80), 802.11ax (HE80), 802.11be (EHT80):

Channel	Frequency	Channel	Frequency
106	5530 MHz	138	5690 MHz
122	5610 MHz		

1 channel is provided for 802.11ac (VHT160), 802.11ax (HE160), 802.11be (EHT160):

Channel	Frequency
114	5570 MHz

FOR 5745 ~ 5825 MHz:

5 channels are provided for 802.11a, 802.11n (HT20), 802.11ac (VHT20), 802.11ax (HE20), 802.11be (EHT20):

Channel	Frequency	Channel	Frequency
149	5745 MHz	161	5805 MHz
153	5765 MHz	165	5825 MHz
157	5785 MHz		

2 channels are provided for 802.11n (HT40), 802.11ac (VHT40), 802.11ax (HE40), 802.11be (EHT40):

Channel	Frequency	Channel	Frequency
151	5755 MHz	159	5795 MHz

1 channel is provided for 802.11ac (VHT80), 802.11ax (HE80), 802.11be (EHT80):

Channel	Frequency
155	5775 MHz

3.4 Test Mode Applicability and Tested Channel Detail

Pre-Scan:	1. Pre-Scan has been conducted to determine the worst-case mode from all possible combinations between available modulations, data rates and antenna ports.
-----------	---

Following channel(s) was (were) selected for the final test as listed below:

Test Item	EUT Configure Mode	Mode	Signal Mode	Tested Channel	Modulation	Data Rate Parameter
AC Power Conducted Emissions	C	802.11be (EHT20)	2S2T	165	BPSK	MCS0
Unwanted Emissions below 1 GHz	A, B	802.11be (EHT20)	2S2T	165	BPSK	MCS0
Unwanted Emissions above 1 GHz	A, B	802.11be (EHT20)	1S1T / 2S2T	149, 157, 165	BPSK	MCS0
		802.11be (EHT40)	1S1T / 2S2T	38, 46, 54, 62		
		802.11be (EHT80)	1S1T / 2S2T	106, 122, 138		
EUT Configure Mode:	A	EUT only (remove 50 ohm terminator and Connect to the appropriate equipment)				
	B	EUT with 50 ohm terminator				
	C	EUT with antenna (Monopole Ant.)				

Note:
The worst SKU is SKU 1. This evaluation condition is determined by referring to the evaluation results of the original report.

3.5 Duty Cycle of Test Signal

802.11be (EHT20) 1S1T: Duty cycle = 3.945 ms / 5.214 ms x 100% = 75.7%, duty factor = 10 * log (1/Duty cycle) = 1.21 dB

802.11be (EHT40) 1S1T: Duty cycle = 3.952 ms / 5.241 ms x 100% = 75.4%, duty factor = 10 * log (1/Duty cycle) = 1.23 dB

802.11be (EHT80) 1S1T: Duty cycle = 1.93 ms / 2.606 ms x 100% = 74.1%, duty factor = 10 * log (1/Duty cycle) = 1.30 dB

802.11be (EHT20) 2S2T: Duty cycle = 2.014 ms / 3.287 ms x 100% = 61.3%, duty factor = 10 * log (1/Duty cycle) = 2.13 dB

802.11be (EHT40) 2S2T: Duty cycle = 2.014 ms / 3.299 ms x 100% = 61.0%, duty factor = 10 * log (1/Duty cycle) = 2.14 dB

802.11be (EHT80) 2S2T: Duty cycle = 1.01 ms / 1.702 ms x 100% = 59.3%, duty factor = 10 * log (1/Duty cycle) = 2.27 dB



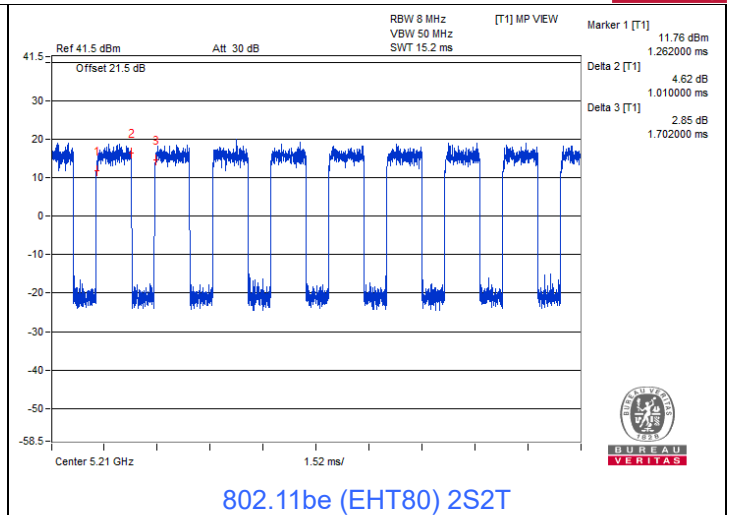
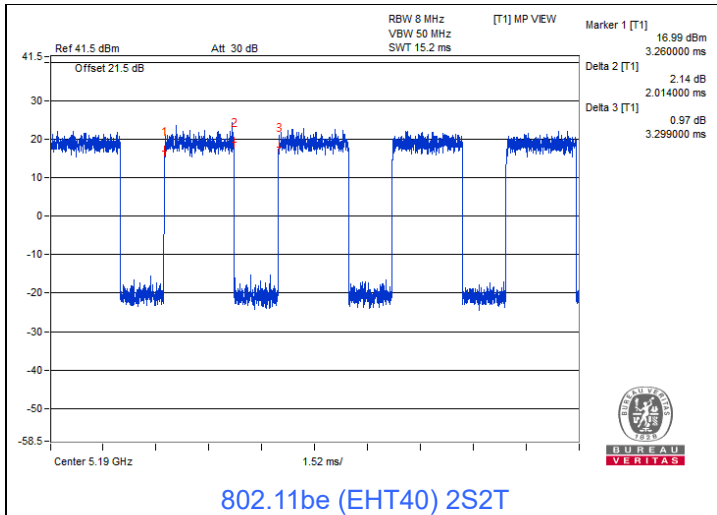

3.6 Test Program Used and Operation Descriptions

Controlling software (Wi-Fi: QAtool_V06 (0.0.2.100)) has been activated to set the EUT under transmission condition continuously at specific channel frequency.

3.7 Connection Diagram of EUT and Peripheral Devices

For AC Power Conducted Emission test

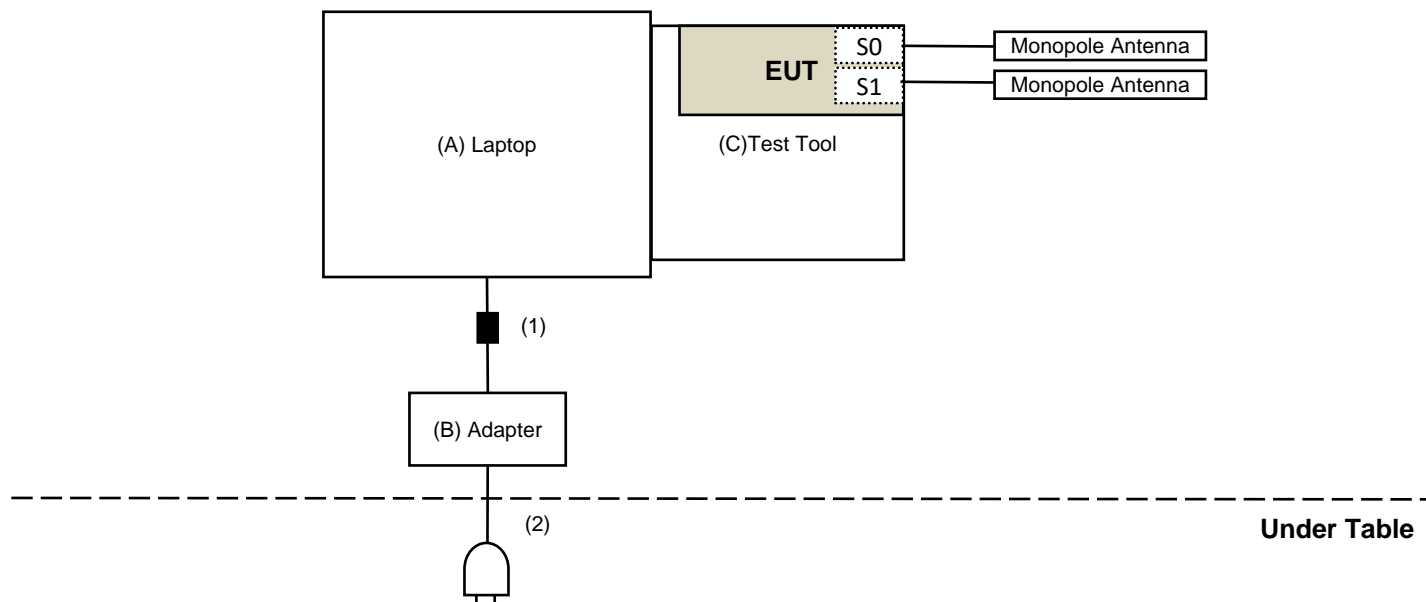

For Unwanted Emission test

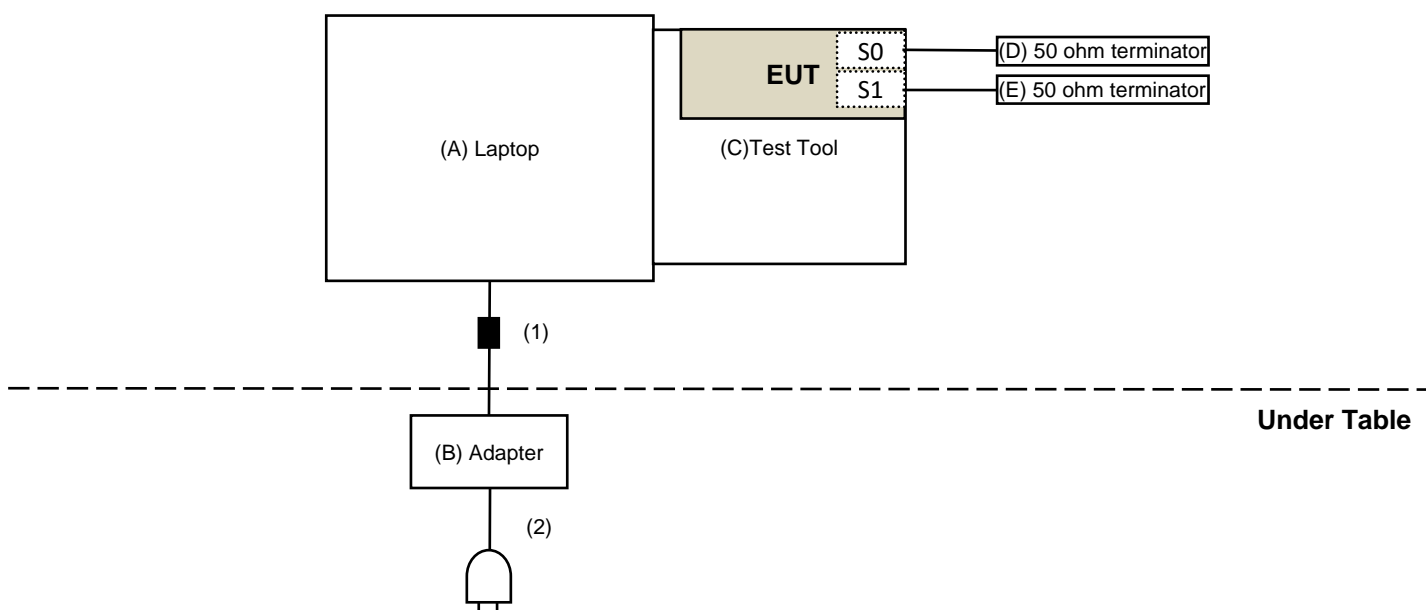

3.8 Configuration of Peripheral Devices and Cable Connections

ID	Product	Brand	Model No.	Serial No.	FCC ID	Remarks
A	Laptop	DELL	E5430	HYV4VY1	DoC	Provided by Lab
B	Adapter	DELL	LLA65NS2-01	N/A	N/A	Provided by Lab
C	Test Tool	Mediatek	MTK1849	N/A	N/A	Supplied by applicant
D	50 Ohm terminator	WOKEN	WTER-18S2	N/A	N/A	Provided by Lab
E	50 Ohm terminator	WOKEN	WTER-18S2	N/A	N/A	Provided by Lab

ID	Cable Descriptions	Qty.	Length (m)	Shielding (Yes/No)	Cores (Qty.)	Remarks
1	DC Cable	1	1.8	No	1	Provided by Lab
2	AC Cable	1	1	No	0	Provided by Lab

4 Test Instruments

The calibration interval of the all test instruments are 12 months and the calibrations are traceable to NML/ROC and NIST/USA.

4.1 AC Power Conducted Emissions

Description Manufacturer	Model No.	Serial No.	Calibrated Date	Calibrated Until
50 ohm terminal resistance Telegartner	50 ohm	3	2023/10/20	2024/10/19
EMI Test Receiver R&S	ESCS 30	847124/029	2023/10/18	2024/10/17
Fixed Attenuator STI	STI02-2200-10	005	2024/2/19	2025/2/18
LISN R&S	ESH3-Z5	835239/001	2024/4/3	2025/4/2
		848773/004	2023/10/13	2024/10/12
RF Coaxial Cable JYEBAO	5D-FB	COCCAB-001	2024/2/19	2025/2/18
Software BVADT	BVADT_Cond_V7.3.7.4	N/A	N/A	N/A

Notes:

1. The test was performed in Conduction 1
2. Tested Date: 2024/5/8

4.2 Unwanted Emissions below 1 GHz

Mode A

Description Manufacturer	Model No.	Serial No.	Calibrated Date	Calibrated Until
MXA Signal Analyzer Keysight	N9020B	MY60112409	2024/2/20	2025/2/19
Software	ADT_RF Test Software V7.6.5.4	N/A	N/A	N/A

Notes:

1. The test was performed in Oven room 2.
2. Tested Date: 2024/5/16

Mode B

Description Manufacturer	Model No.	Serial No.	Calibrated Date	Calibrated Until
Bi_Log Antenna Schwarzbeck	VULB 9168	9168-406	2023/10/13	2024/10/12
Boresight Antenna Tower & Turn Table Max-Full	MF-7802BS	MF780208530	N/A	N/A
Fixed Attenuator Mini-Circuits	UNAT-5+	PAD-ATT5-03	2024/2/17	2025/2/16
Loop Antenna Electro-Metrics	EM-6879	264	2024/2/23	2025/2/22
MXA Signal Analyzer Keysight	N9020B	MY60112408	2024/3/7	2025/3/6
MXE EMI Receiver Keysight	N9038A	MY59050100	2023/6/13	2024/6/12
Preamplifier EMCI	EMC330N	980701	2024/2/17	2025/2/16
	EMC001340	980142	2024/2/19	2025/2/18
RF Coaxial Cable JYEBAO	5D-FB	LOOPCAB-001	2024/2/19	2025/2/18
		LOOPCAB-002	2024/2/19	2025/2/18
RF Coaxial Cable mTJ	100100-CFD400LW-200	CFD400-200	2024/2/17	2025/2/16
	100100-CFD400LW-400	CFD400-400	2024/2/17	2025/2/16
	100100-CFD400LW-800	CFD400-800	2024/2/17	2025/2/16
Software	ADT_Radiated_V8.7.08	N/A	N/A	N/A

Notes:

1. The test was performed in 966 Chamber No. 4.
2. Tested Date: 2024/5/8

4.3 Unwanted Emissions above 1 GHz

Mode A

Refer to section 4.2 to Mode A

Mode B

Description Manufacturer	Model No.	Serial No.	Calibrated Date	Calibrated Until
Boresight Antenna Tower & Turn Table Max-Full	MF-7802BS	MF780208530	N/A	N/A
Horn Antenna Schwarzbeck	BBHA 9120D	9120D-783	2023/11/12	2024/11/11
	BBHA 9170	9170-739	2023/11/12	2024/11/11
MXA Signal Analyzer Keysight	N9020B	MY60112408	2024/3/7	2025/3/6
Preamplifier EMCI	EMC12630SE	980688	2023/10/3	2024/10/2
	EMC184045SE	980387	2023/8/9	2024/8/8
RF Coaxial Cable EMCI	EMC102-KM-KM-1200	160924	2024/1/29	2025/1/28
	EMC102-KM-KM-4000	200214	2024/1/29	2025/1/28
	EMC104-SM-SM-1200	160922	2024/1/29	2025/1/28
	EMC104-SM-SM-2000	180502	2024/1/29	2025/1/28
	EMC104-SM-SM-6000	210704	2023/11/2	2024/11/1
Software	ADT_Radiated_V8.7.08	N/A	N/A	N/A

Notes:

1. The test was performed in 966 Chamber No. 4.
2. Tested Date: 2024/5/7 ~ 2024/5/8

5 Limits of Test Items

5.1 AC Power Conducted Emissions

Frequency (MHz)	Conducted Limit (dBuV)	
	Quasi-peak	Average
0.15 - 0.5	66 - 56	56 - 46
0.50 - 5.0	56	46
5.0 - 30.0	60	50

Notes:

1. The lower limit shall apply at the transition frequencies.
2. The limit decreases in line with the logarithm of the frequency in the range of 0.15 to 0.50 MHz.

5.2 Unwanted Emissions below 1 GHz

Radiated emissions which fall in the restricted bands must comply with the radiated emission limits specified as below table.

Frequencies (MHz)	Field Strength (microvolts/meter)	Measurement Distance (meters)
0.009 ~ 0.490	2400/F(kHz)	300
0.490 ~ 1.705	24000/F(kHz)	30
1.705 ~ 30.0	30	30
30 ~ 88	100	3
88 ~ 216	150	3
216 ~ 960	200	3
Above 960	500	3

Notes:

1. The lower limit shall apply at the transition frequencies.
2. Emission level (dBuV/m) = 20 log Emission level (uV/m).

5.3 Unwanted Emissions above 1 GHz

Radiated emissions which fall in the restricted bands must comply with the radiated emission limits specified as below table.

Frequencies (MHz)	Field Strength (microvolts/meter)	Measurement Distance (meters)
Above 960	500	3

Notes:

1. The lower limit shall apply at the transition frequencies.
2. Emission level (dBuV/m) = 20 log Emission level (uV/m).
3. For frequencies above 1000 MHz, the field strength limits are based on average detector, however, the peak field strength of any emission shall not exceed the maximum permitted average limits, specified above by more than 20 dB under any condition of modulation.

Limits of unwanted emission out of the restricted bands

Applicable To	Limit	
789033 D02 General UNII Test Procedure New Rules v02r01	Field Strength at 3 m	
	PK: 74 (dBµV/m)	AV: 54 (dBµV/m)

For transmitters operating in the 5.15-5.25 GHz band:

Applicable To	EIRP Limit	Equivalent Field Strength at 3 m
15.407(b)(1)	PK: -27 (dBm/MHz)	PK: 68.2 (dBµV/m)

For transmitters operating in the 5.25-5.35 GHz band:

Applicable To	EIRP Limit	Equivalent Field Strength at 3 m
15.407(b)(2)	PK: -27 (dBm/MHz)	PK: 68.2 (dBµV/m)

For transmitters operating in the 5.47-5.725 GHz band:

Applicable To	EIRP Limit	Equivalent Field Strength at 3 m
15.407(b)(3)	PK: -27 (dBm/MHz)	PK: 68.2 (dBµV/m)

For transmitters operating in the 5.725-5.850 GHz band:

Applicable To	EIRP Limit	Equivalent Field Strength at 3 m
15.407(b)(4)(i)	PK: -27 (dBm/MHz) ^{*1}	PK: 68.2 (dBµV/m) ^{*1}
	PK: 10 (dBm/MHz) ^{*2}	PK: 105.2 (dBµV/m) ^{*2}
	PK: 15.6 (dBm/MHz) ^{*3}	PK: 110.8 (dBµV/m) ^{*3}
	PK: 27 (dBm/MHz) ^{*4}	PK: 122.2 (dBµV/m) ^{*4}

^{*1} beyond 75 MHz or more above of the band edge.

^{*2} below the band edge increasing linearly to 10 dBm/MHz at 25 MHz above.

^{*3} below the band edge increasing linearly to a level of 15.6 dBm/MHz at 5 MHz above.

^{*4} from 5 MHz above or below the band edge increasing linearly to a level of 27 dBm/MHz at the band edge.

Note: The following formula is used to convert the equipment isotropic radiated power (eirp) to field strength:

$$E = \frac{1000000\sqrt{30P}}{3} \mu\text{V/m, where P is the eirp (Watts).}$$

6 Test Arrangements

6.1 AC Power Conducted Emissions

6.1.1 Test Setup

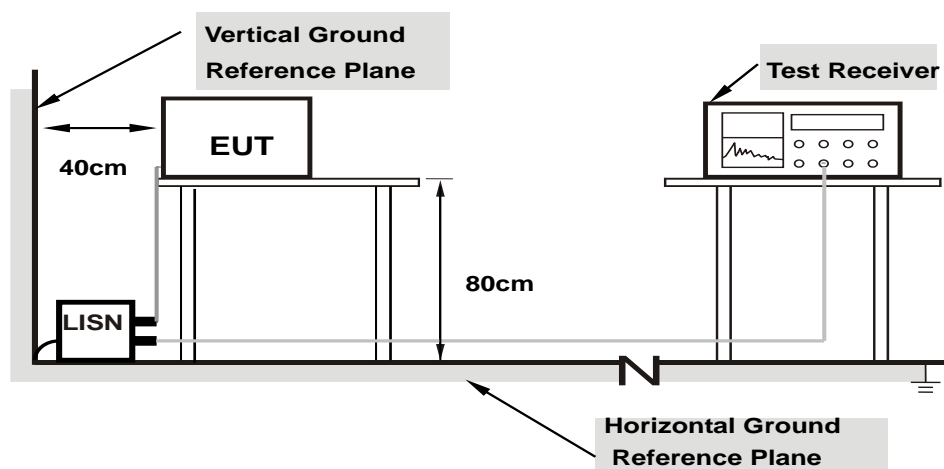

Note: 1.Support units were connected to second LISN.

For the actual test configuration, please refer to the attached file (Test Setup Photo).

6.1.2 Test Procedure

- The EUT was placed on a 0.8 meter to the top of table and placed 0.4 meters from the conducting wall of the shielded room with EUT being connected to the power mains through a line impedance stabilization network (LISN). Other support units were connected to the power mains through another LISN. The two LISNs provide 50 ohm/ 50 uH of coupling impedance for the measuring instrument.
- Both lines of the power mains connected to the EUT were checked for maximum conducted interference.
- The frequency range from 150 kHz to 30 MHz was searched. Emission levels under (Limit – 20 dB) was not recorded.

Note: The resolution bandwidth and video bandwidth of test receiver is 9 kHz for quasi-peak detection (QP) and average detection (AV) at frequency 0.15 MHz-30 MHz.

6.2 Unwanted Emissions below 1 GHz

6.2.1 Test Setup

For Conducted Configuration:

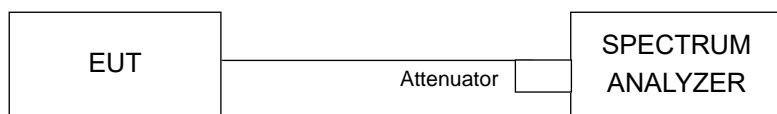

For Radiated Configuration:

For Radiated emission below 30 MHz

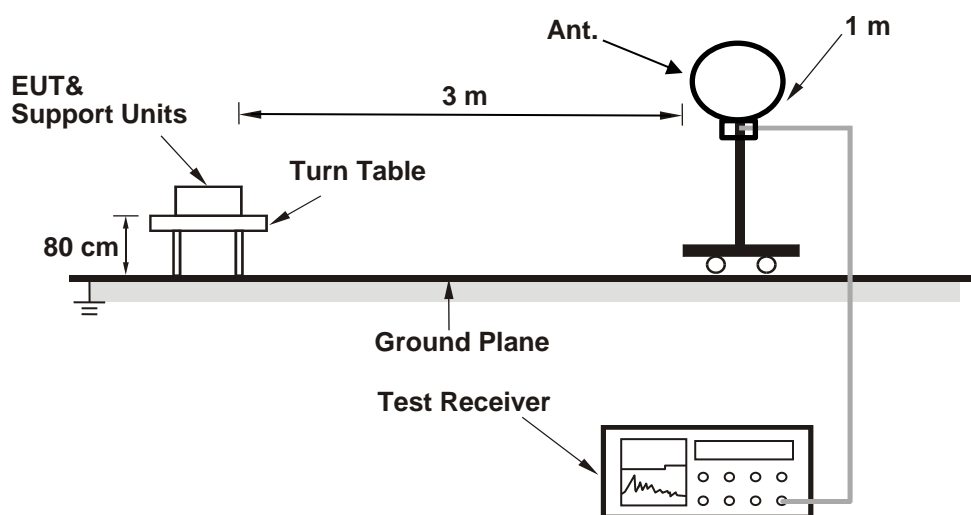

For Radiated emission above 30 MHz

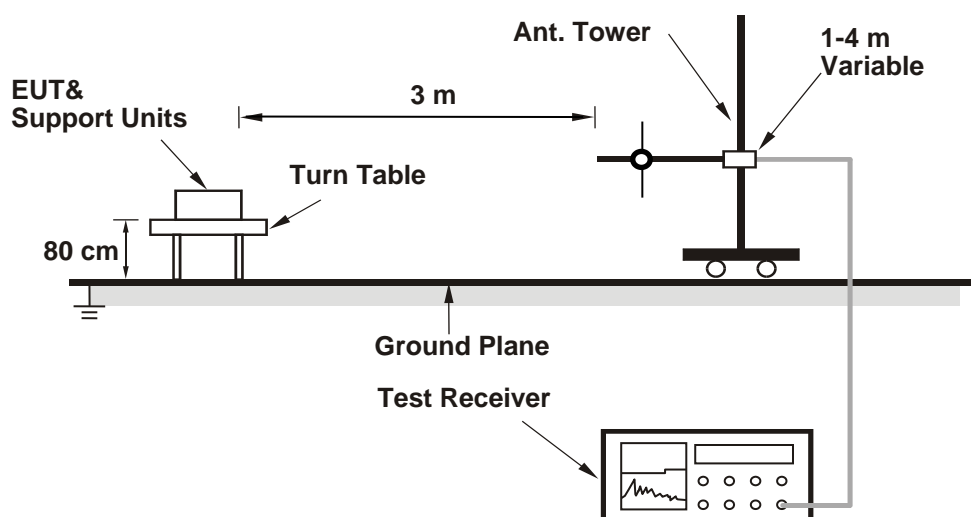

For the actual test configuration, please refer to the attached file (Test Setup Photo).

6.2.2 Test Procedure

Following FCC KDB 789033 D02 General UNII Test Procedures:

Radiated versus Conducted Measurements.

The unwanted emission limits in both the restricted and non-restricted bands are based on antenna-port conducted measurements in conjunction with cabinet emissions tests are permitted to demonstrate compliance.

The following steps was performed:

- a. Cabinet emissions measurements. Radiated measurement was performed to ensure that cabinet emissions are below the emission limits. For the cabinet-emission measurements the antenna was replaced by a termination matching the nominal impedance of the antenna.
- b. Conducted tests was performed using equipment that matches the nominal impedance of the antenna assembly used with the EUT.
- c. EIRP calculation. A value representative of an upper bound on out-of-band antenna gain (in dBi) shall be added to the measured antenna-port conducted emission power to compute EIRP within the specified measurement bandwidth. (For emissions in the restricted bands, additional calculations are required to convert EIRP to field strength at the specified distance.) The upper bound on antenna gain for a device with a single RF output shall be selected as the maximum in-band gain of the antenna across all operating bands or 2 dBi, whichever is greater.
- d. EIRP adjustments for multiple outputs. (Follow the procedures specified in FCC KDB Publication 662911)
- e. For all of Radiation emission test

For Radiated emission below 30 MHz

- a. The EUT was placed on the top of a rotating table 0.8 meters above the ground at 3 meter chamber room for test. The table was rotated 360 degrees to determine the position of the highest radiation.
- b. The EUT was set 3 meters away from the interference-receiving antenna, which was mounted on the top of a variable-height antenna tower.
- c. Parallel, perpendicular, and ground-parallel orientations of the antenna are set to make the measurement.
- d. For each suspected emission, the EUT was arranged to its worst case and the rotatable table was turned from 0 degrees to 360 degrees to find the maximum reading.
- e. The test-receiver system was set to Quasi-Peak Detect Function and Specified Bandwidth with Maximum Hold Mode, except for the frequency band (9 kHz to 90 kHz and 110 kHz to 490 kHz) set to average detect function and peak detect function.

Notes:

1. The resolution bandwidth and video bandwidth of test receiver/spectrum analyzer is 200 Hz at frequency below 150 kHz.
2. The resolution bandwidth and video bandwidth of test receiver/spectrum analyzer is 9 kHz or 10 kHz at frequency (150 kHz to 30 MHz).
3. All modes of operation were investigated and the worst-case emissions are reported.

For Radiated emission above 30 MHz

- a. The EUT was placed on the top of a rotating table 0.8 meters above the ground at 3 meter chamber room for test. The table was rotated 360 degrees to determine the position of the highest radiation.
- b. The EUT was set 3 meters away from the interference-receiving antenna, which was mounted on the top of a variable-height antenna tower.
- c. The height of antenna is varied from one meter to four meters above the ground to determine the maximum value of the field strength. Both horizontal and vertical polarizations of the antenna are set to make the measurement.
- d. For each suspected emission, the EUT was arranged to its worst case and then the antenna was tuned to heights from 1 meter to 4 meters and the rotatable table was turned from 0 degrees to 360 degrees to find the maximum reading.
- e. The test-receiver system was set to quasi-peak detect function and specified bandwidth with maximum hold mode when the test frequency is below 1 GHz.

Notes:

1. The resolution bandwidth and video bandwidth of test receiver/spectrum analyzer is 120 kHz for Quasi-peak detection (QP) at frequency below 1 GHz.
2. All modes of operation were investigated and the worst-case emissions are reported.

6.3 Unwanted Emissions above 1 GHz

6.3.1 Test Setup

For Conducted Configuration:

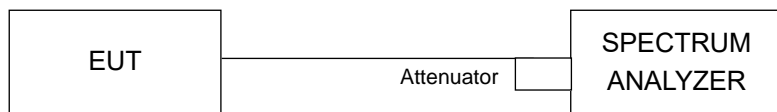

For Radiated Configuration:

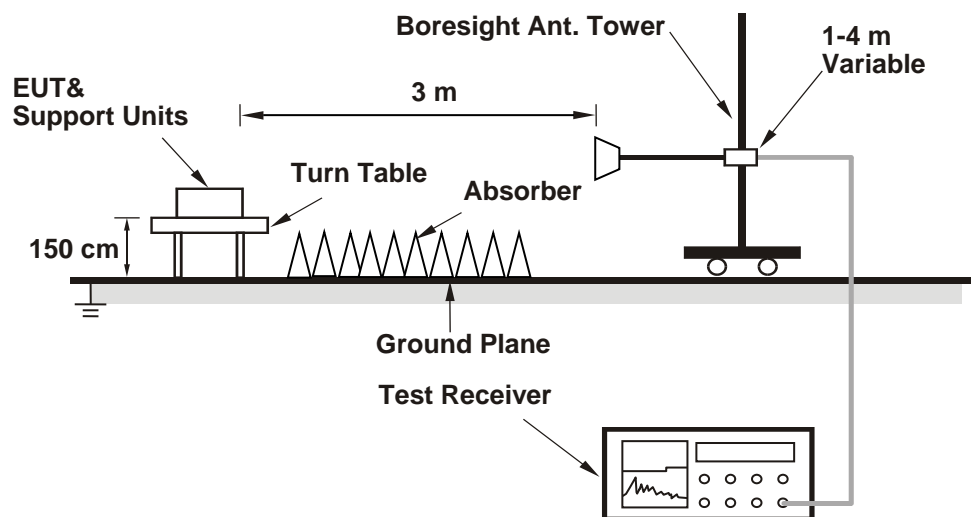

For the actual test configuration, please refer to the attached file (Test Setup Photo).

6.3.2 Test Procedure

Following FCC KDB 789033 D02 General UNII Test Procedures:

Radiated versus Conducted Measurements.

The unwanted emission limits in both the restricted and non-restricted bands are based on antenna-port conducted measurements in conjunction with cabinet emissions tests are permitted to demonstrate compliance.

The following steps was performed:

- a. Cabinet emissions measurements. Radiated measurement was performed to ensure that cabinet emissions are below the emission limits. For the cabinet-emission measurements the antenna was replaced by a termination matching the nominal impedance of the antenna.
- b. Conducted tests was performed using equipment that matches the nominal impedance of the antenna assembly used with the EUT.
- c. EIRP calculation. A value representative of an upper bound on out-of-band antenna gain (in dBi) shall be added to the measured antenna-port conducted emission power to compute EIRP within the specified measurement bandwidth. (For emissions in the restricted bands, additional calculations are required to convert EIRP to field strength at the specified distance.) The upper bound on antenna gain for a device with a single RF output shall be selected as the maximum in-band gain of the antenna across all operating bands or 2 dBi, whichever is greater.
- d. EIRP adjustments for multiple outputs. (Follow the procedures specified in FCC KDB Publication 662911)
- e. For all of Radiation emission test

For Radiated emission above 1 GHz

- a. The EUT was placed on the top of a rotating table 1.5 meters above the ground at 3 meter chamber room for test. The table was rotated 360 degrees to determine the position of the highest radiation.
- b. The EUT was set 3 meters away from the interference-receiving antenna, which was mounted on the top of a variable-height antenna tower.
- c. The height of antenna is varied from one meter to four meters above the ground to determine the maximum value of the field strength. Both horizontal and vertical polarizations of the antenna are set to make the measurement.
- d. For each suspected emission, the EUT was arranged to its worst case and then the antenna was tuned to heights from 1 meter to 4 meters and the rotatable table was turned from 0 degrees to 360 degrees to find the maximum reading.
- e. The test-receiver system was set to peak and average detects function and specified bandwidth with maximum hold mode when the test frequency is above 1 GHz. If the peak reading value also meets average limit, measurement with the average detector is unnecessary.

Notes:

1. The resolution bandwidth of test receiver/spectrum analyzer is 1 MHz and the video bandwidth is 3 MHz for Peak detection (PK) and Average detection (AV) at frequency above 1 GHz.
2. For fundamental and harmonic signal measurement, the resolution bandwidth of test receiver/spectrum analyzer is 1 MHz and the video bandwidth is $\geq 1/T$ (Duty cycle < 98%) or 10 Hz (Duty cycle $\geq 98\%$) for Average detection (AV) at frequency above 1 GHz.
3. All modes of operation were investigated and the worst-case emissions are reported.

7 Test Results of Test Item

7.1 AC Power Conducted Emissions

Mode C 2S2T

RF Mode	802.11be (EHT20)	Channel	CH 165 : 5825 MHz
Frequency Range	150 kHz ~ 30 MHz	Detector Function & Resolution Bandwidth	Quasi-Peak (QP) / Average (AV), 9 kHz
Input Power (System)	120 Vac, 60 Hz	Environmental Conditions	22 °C, 72 % RH
Tested By	Sampson Chen		

Phase Of Power : Line (L)

No	Frequency (MHz)	Correction Factor (dB)	Reading Value (dBuV)		Emission Level (dBuV)		Limit (dBuV)		Margin (dB)	
			Q.P.	AV.	Q.P.	AV.	Q.P.	AV.	Q.P.	AV.
1	0.15781	9.94	48.65	32.67	58.59	42.61	65.58	55.58	-6.99	-12.97
2	0.18516	9.94	26.60	12.99	36.54	22.93	64.25	54.25	-27.71	-31.32
3	0.20859	9.94	40.28	23.04	50.22	32.98	63.26	53.26	-13.04	-20.28
4	0.36875	9.95	21.66	7.27	31.61	17.22	58.53	48.53	-26.92	-31.31
5	2.98828	10.09	20.39	13.76	30.48	23.85	56.00	46.00	-25.52	-22.15
6	23.35938	11.09	20.77	15.19	31.86	26.28	60.00	50.00	-28.14	-23.72

Remarks:

1. Q.P. and AV. are abbreviations of quasi-peak and average individually.
2. The emission levels of other frequencies were very low against the limit.
3. Margin value = Emission level – Limit value
4. Correction factor = Insertion loss + Cable loss
5. Emission Level = Correction Factor + Reading Value

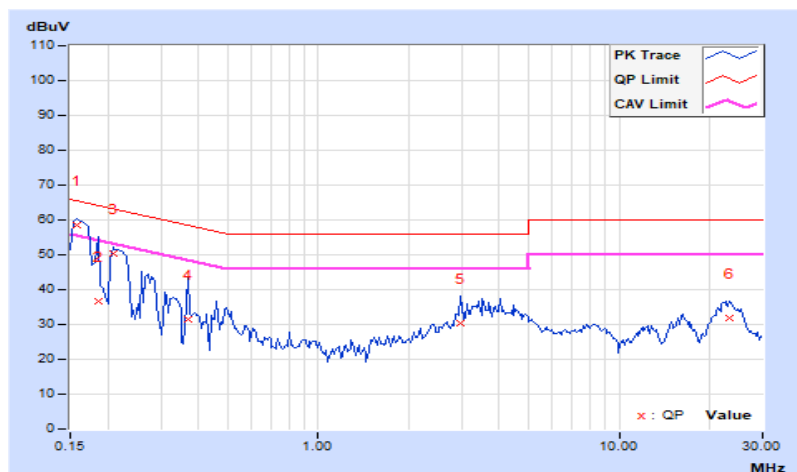

RF Mode	802.11be (EHT20)	Channel	CH 165 : 5825 MHz
Frequency Range	150 kHz ~ 30 MHz	Detector Function & Resolution Bandwidth	Quasi-Peak (QP) / Average (AV), 9 kHz
Input Power (System)	120 Vac, 60 Hz	Environmental Conditions	22 °C, 72 % RH
Tested By	Sampson Chen		

Phase Of Power : Neutral (N)										
No	Frequency (MHz)	Correction Factor (dB)	Reading Value (dBuV)		Emission Level (dBuV)		Limit (dBuV)		Margin (dB)	
			Q.P.	AV.	Q.P.	AV.	Q.P.	AV.	Q.P.	AV.
1	0.15000	9.97	44.59	21.34	54.56	31.31	66.00	56.00	-11.44	-24.69
2	0.16953	9.98	44.94	27.12	54.92	37.10	64.98	54.98	-10.06	-17.88
3	0.20859	9.99	37.49	21.16	47.48	31.15	63.26	53.26	-15.78	-22.11
4	0.25938	9.99	31.31	14.00	41.30	23.99	61.45	51.45	-20.15	-27.46
5	3.48438	10.16	23.22	15.74	33.38	25.90	56.00	46.00	-22.62	-20.10
6	4.05469	10.19	21.71	15.93	31.90	26.12	56.00	46.00	-24.10	-19.88

Remarks:

1. Q.P. and AV. are abbreviations of quasi-peak and average individually.
2. The emission levels of other frequencies were very low against the limit.
3. Margin value = Emission level – Limit value
4. Correction factor = Insertion loss + Cable loss
5. Emission Level = Correction Factor + Reading Value

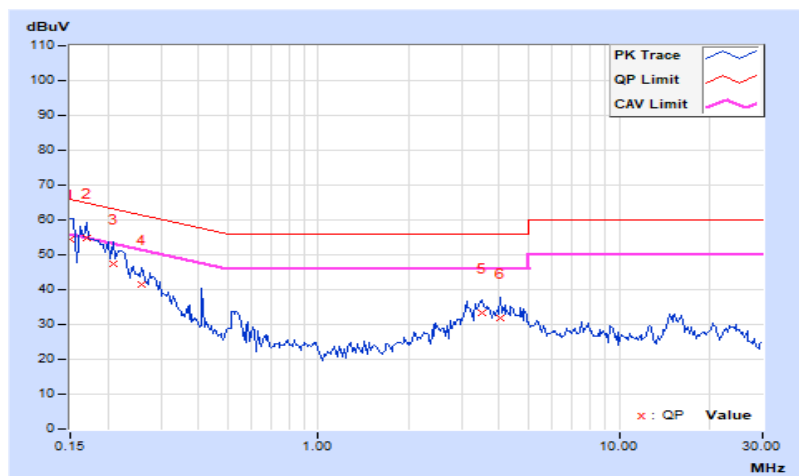

7.2 Unwanted Emissions below 1 GHz

Radiated versus Conducted Measurement

For Radiated measurement:

The level of unwanted emissions was measured when radiated by the cabinet or structure of the equipment with the antenna connector(s) terminated by a specified load (cabinet radiation)

For Conducted measurement:

The level of unwanted emissions was measured as their power in a specified load (conducted spurious emissions).

Conducted Emission Convert Formula

a. $\text{Emission Level (dBuV/m)} = \text{EIRP Level (dBm)} - 20\log(d) + 104.8$

d = measurement distance in 3 meters.

b. $\text{EIRP Level (dBm)} = \text{Raw Value(dBm)} + \text{Correction Factor(dB)}$

c. Correction Factor is directional gain, and the composite gain will be used when signal support the correlated signal

For the out of band spurious the gain for the specific band may have been used rather than the highest gain across all bands.

For the band edge the gain for the specific band may have been used.

Notes:

1. In restricted bands below 1000 MHz, add upper bound on ground plane reflection:

For $f = 30 - 1000$ MHz, add 4.7 dB.

2. The conducted emission test was considered some factor to compute test result.

Mode A 2S2T

802.11be (EHT20) - Channel 165

Conducted spurious emission table

No.	Frequency (MHz)	Emission Level (dBuV/m)	Limit (dBuV/m)	Margin (dB)	Raw Value (dBm)		Correction Factor (dB)	EIRP Level (dBm)
					Chain0	Chain1		
1	33.88	32.37	40	-7.63	-70.3	-71.42	4.92	-62.89
2	120.94	33.21	43.5	-10.29	-69.52	-70.5	4.92	-62.05
3	298.57	32.91	46	-13.09	-70.05	-70.53	4.92	-62.35
4	439.1	33.77	46	-12.23	-71.4	-68.06	4.92	-61.49
5	775.08	34.48	46	-11.52	-71	-67.22	4.92	-60.78
6	935.98	34.57	46	-11.43	-67.75	-69.72	4.92	-60.69

Remarks:

1. Margin value = Emission Level – Limit value
2. The other emission levels were very low against the limit.
3. The frequency range 9 kHz ~ 30 MHz: all emissions are more than 20 dB below the limit, therefore do not be recorded in this report.

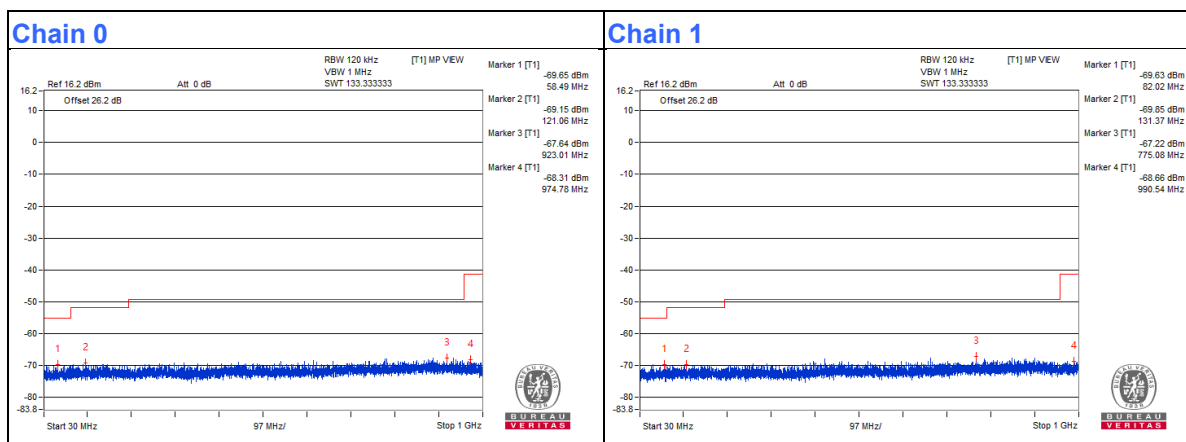

Mode B 2S2T

RF Mode	802.11be (EHT20)	Channel	CH 165 : 5825 MHz
Frequency Range	30 MHz ~ 1 GHz	Detector Function & Bandwidth	QP: RB=120kHz, DET=Quasi-Peak
Input Power (System)	120 Vac, 60 Hz	Environmental Conditions	22.0 °C, 69.0 % RH
Tested By	Sampson Chen		

Antenna Polarity & Test Distance : Horizontal at 3 m								
No	Frequency (MHz)	Emission Level (dBuV/m)	Limit (dBuV/m)	Margin (dB)	Antenna Height (m)	Table Angle (Degree)	Raw Value (dBuV)	Correction Factor (dB/m)
1	216.17	39.8 QP	46.0	-6.2	1.50 H	125	56.2	-16.4
2	240.12	41.5 QP	46.0	-4.5	3.00 H	344	56.0	-14.5
3	300.27	45.1 QP	46.0	-0.9	1.50 H	258	57.5	-12.4
4	326.43	40.5 QP	46.0	-5.5	2.00 H	323	52.0	-11.5
5	702.57	42.6 QP	46.0	-3.4	1.50 H	51	46.5	-3.9
6	840.34	40.8 QP	46.0	-5.2	3.00 H	298	42.4	-1.6

Remarks:

1. Emission Level(dBuV/m) = Raw Value(dBuV) + Correction Factor(dB/m)
2. Correction Factor(dB/m) = Antenna Factor(dB/m) + Cable Factor(dB) – Pre-Amplifier Factor(dB)
3. Margin value = Emission Level – Limit value
4. The other emission levels were very low against the limit of frequency range 30 MHz ~ 1 GHz.
5. The frequency range 9 kHz ~ 30 MHz: all emissions are more than 20 dB below the limit, therefore do not be recorded in this report.

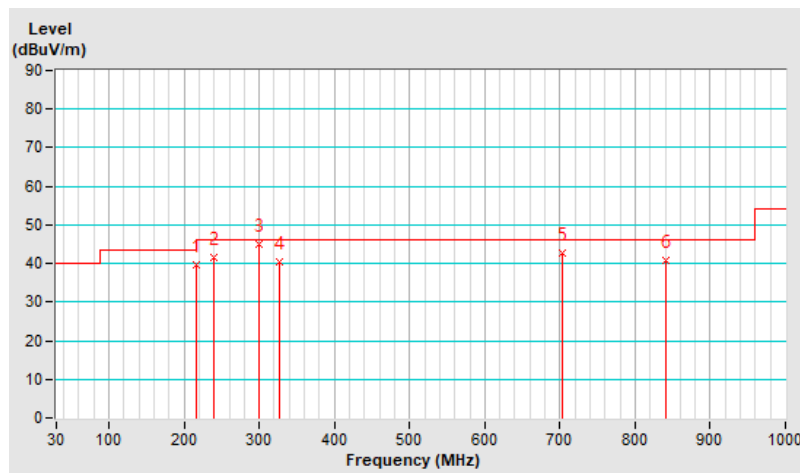

RF Mode	802.11be (EHT20)	Channel	CH 165 : 5825 MHz
Frequency Range	30 MHz ~ 1 GHz	Detector Function & Bandwidth	QP: RB=120kHz, DET=Quasi-Peak
Input Power (System)	120 Vac, 60 Hz	Environmental Conditions	22.0 °C, 69.0 % RH
Tested By	Sampson Chen		

Antenna Polarity & Test Distance : Vertical at 3 m								
No	Frequency (MHz)	Emission Level (dBuV/m)	Limit (dBuV/m)	Margin (dB)	Antenna Height (m)	Table Angle (Degree)	Raw Value (dBuV)	Correction Factor (dB/m)
1	100.69	30.3 QP	43.5	-13.2	1.00 V	253	47.4	-17.1
2	146.05	28.1 QP	43.5	-15.4	3.00 V	223	41.0	-12.9
3	245.10	35.5 QP	46.0	-10.5	2.00 V	127	49.8	-14.3
4	302.25	41.4 QP	46.0	-4.6	3.00 V	55	53.7	-12.3
5	336.43	30.5 QP	46.0	-15.5	2.00 V	56	41.9	-11.4
6	700.77	39.8 QP	46.0	-6.2	2.00 V	312	43.7	-3.9

Remarks:

1. Emission Level(dBuV/m) = Raw Value(dBuV) + Correction Factor(dB/m)
2. Correction Factor(dB/m) = Antenna Factor(dB/m) + Cable Factor(dB) – Pre-Amplifier Factor(dB)
3. Margin value = Emission Level – Limit value
4. The other emission levels were very low against the limit of frequency range 30 MHz ~ 1 GHz.
5. The frequency range 9 kHz ~ 30 MHz: all emissions are more than 20 dB below the limit, therefore do not be recorded in this report.

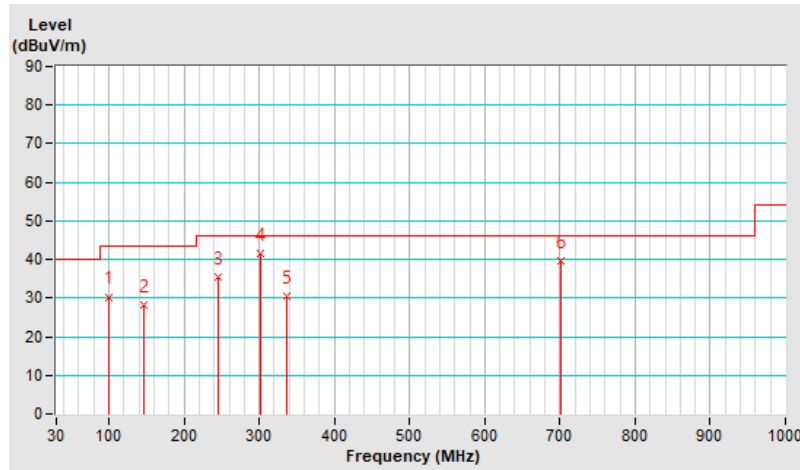

7.3 Unwanted Emissions above 1 GHz

Radiated versus Conducted Measurement

For Radiated measurement:

The level of unwanted emissions was measured when radiated by the cabinet or structure of the equipment with the antenna connector(s) terminated by a specified load (cabinet radiation)

For Conducted measurement:

The level of unwanted emissions was measured as their power in a specified load (conducted spurious emissions).

Conducted Emission Convert Formula

a. $\text{Emission Level (dBuV/m)} = \text{EIRP Level (dBm)} - 20\log(d) + 104.8$

d = measurement distance in 3 meters.

b. $\text{EIRP Level (dBm)} = \text{Raw Value(dBm)} + \text{Correction Factor(dB)}$

c. Correction Factor is directional gain, and the composite gain will be used when signal support the correlated signal

For the out of band spurious the gain for the specific band may have been used rather than the highest gain across all bands.

For the band edge the gain for the specific band may have been used.

Notes: The conducted emission test was considered some factor to compute test result.

Mode A 1S1T
802.11be (EHT20) - Channel 149
Conducted spurious emission table

No.	Frequency (MHz)	Emission Level (dBuV/m)	Limit (dBuV/m)	Margin (dB)	Raw Value (dBm)	Correction Factor (dB)	EIRP Level (dBm)
1	3848.44	64.75 PK	74	-9.25	-35.43	4.92	-30.51
2	3810.94	43.18 AV	54	-10.82	-57	4.92	-52.08
3	7648.44	62.96 PK	74	-11.04	-37.22	4.92	-32.30
4	7676.56	41.05 AV	54	-12.95	-59.13	4.92	-54.21
5	11503.12	62.94 PK	74	-11.06	-37.24	4.92	-32.32
6	11475	41.83 AV	54	-12.17	-58.35	4.92	-53.43
7	#17224.56	54.02 PK	68.2	-14.18	-46.16	4.92	-41.24

Remarks:

1. Margin value = Emission Level – Limit value
2. The other emission levels were very low against the limit.
3. " # " : The frequency is out of the restricted band.

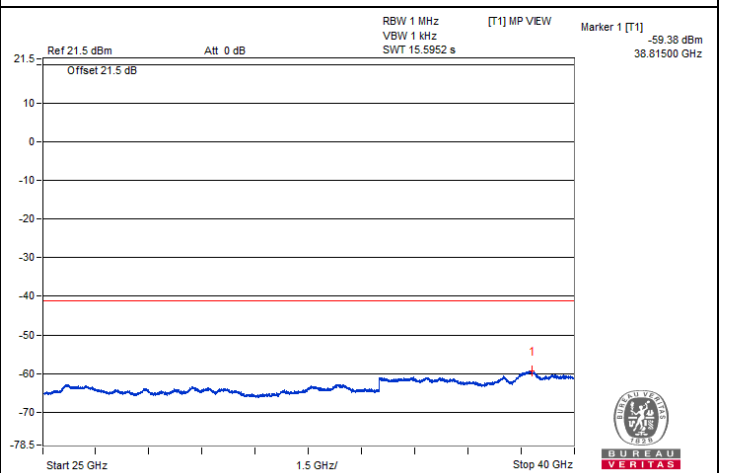
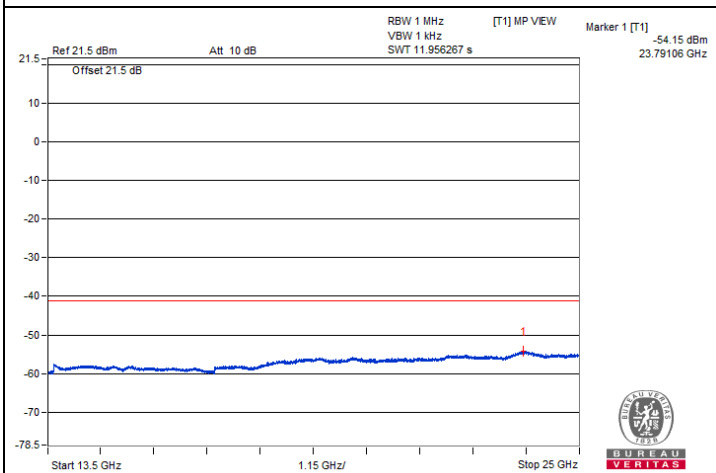
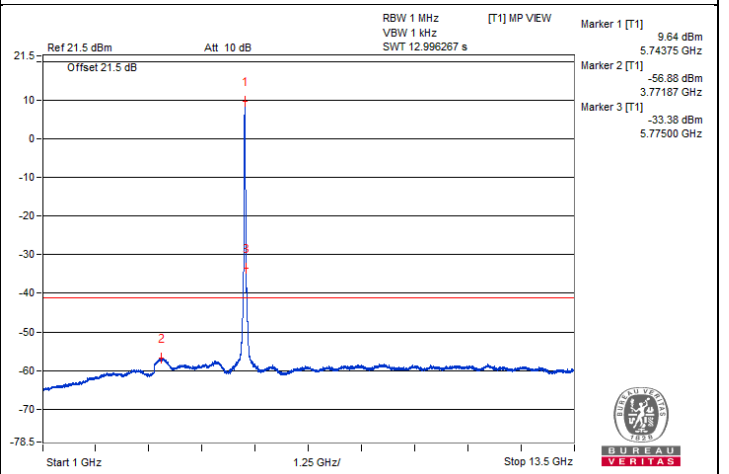
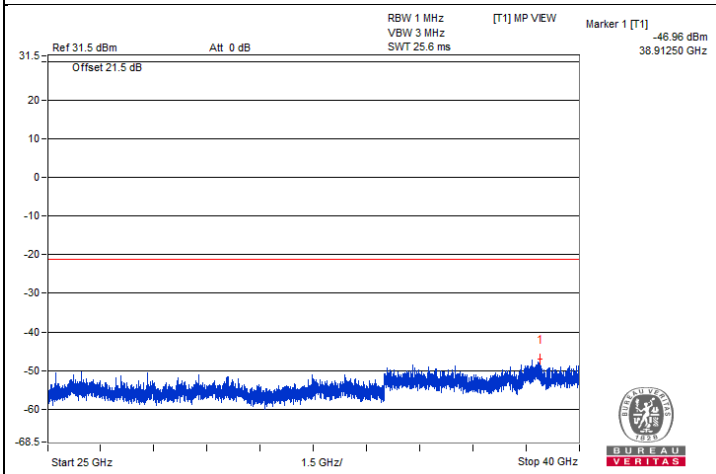
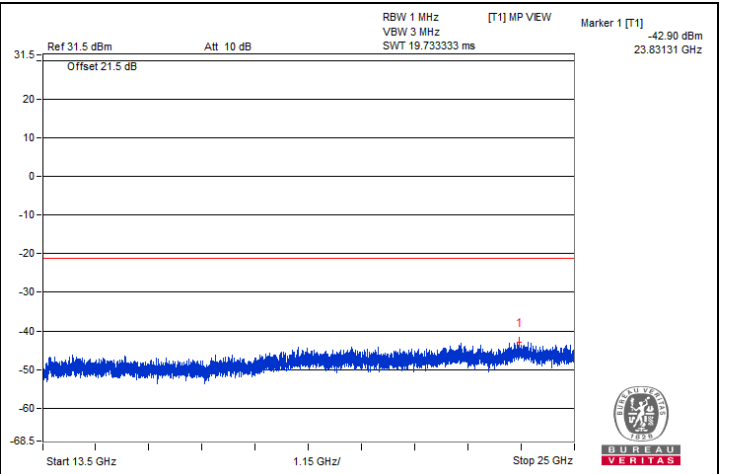
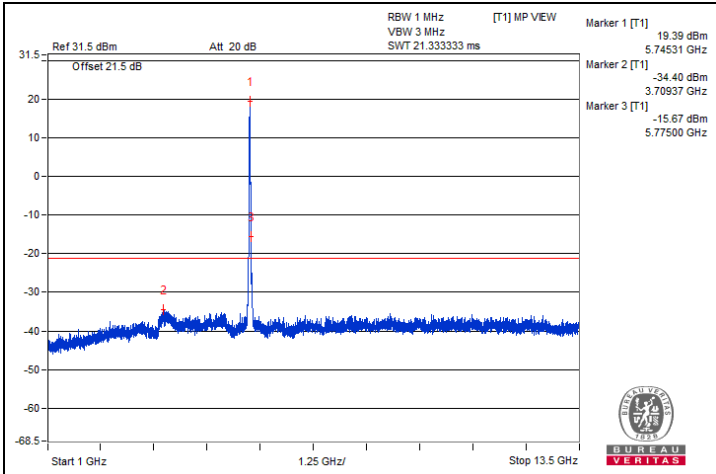



Bandedge table

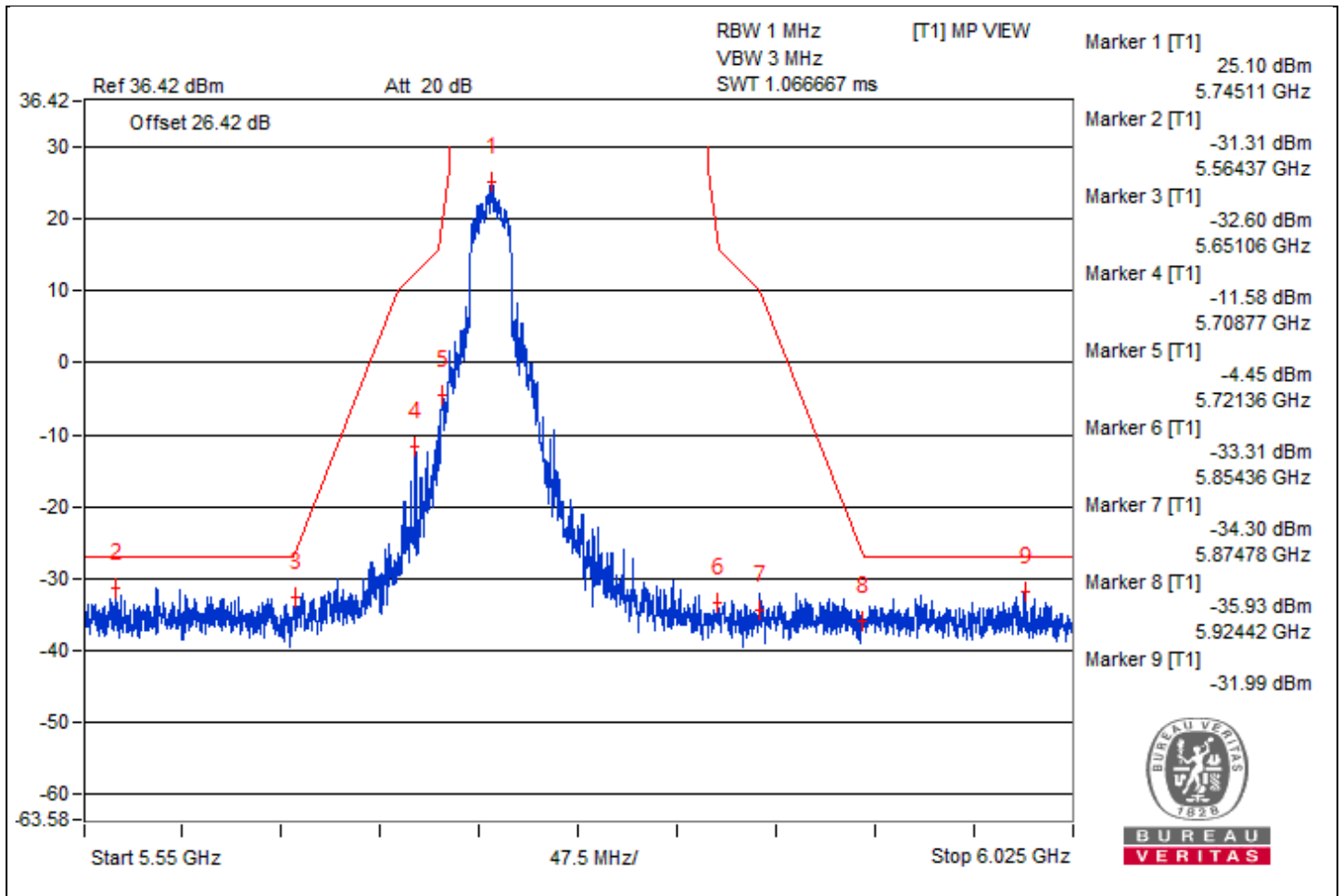

802.11be (EHT20) - Channel 157
Conducted spurious emission table

No.	Frequency (MHz)	Emission Level (dBuV/m)	Limit (dBuV/m)	Margin (dB)	Raw Value (dBm)	Correction Factor (dB)	EIRP Level (dBm)
1	3845.31	64.51 PK	74	-9.49	-35.67	4.92	-30.75
2	3862.5	43.17 AV	54	-10.83	-57.01	4.92	-52.09
3	7721.87	62.74 PK	74	-11.26	-37.44	4.92	-32.52
4	7720.31	41.2 AV	54	-12.8	-58.98	4.92	-54.06
5	11557.81	63.36 PK	74	-10.64	-36.82	4.92	-31.90
6	11556.25	41.26 AV	54	-12.74	-58.92	4.92	-54.00
7	#17346.75	53 PK	68.2	-15.2	-47.18	4.92	-42.26

Remarks:

1. Margin value = Emission Level – Limit value
2. The other emission levels were very low against the limit.
3. " # " : The frequency is out of the restricted band.

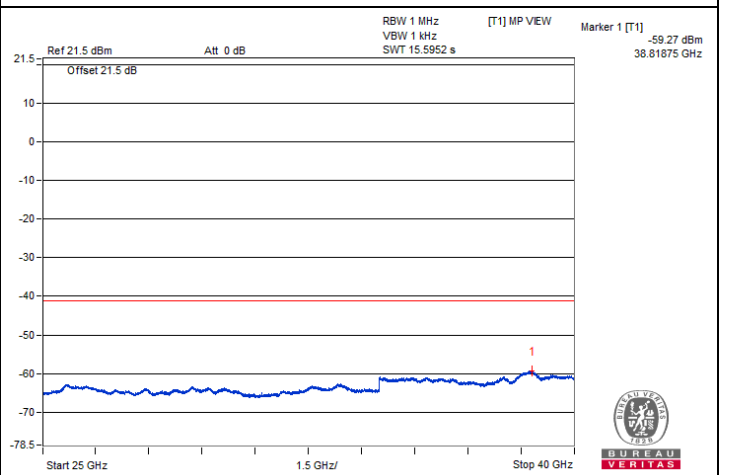
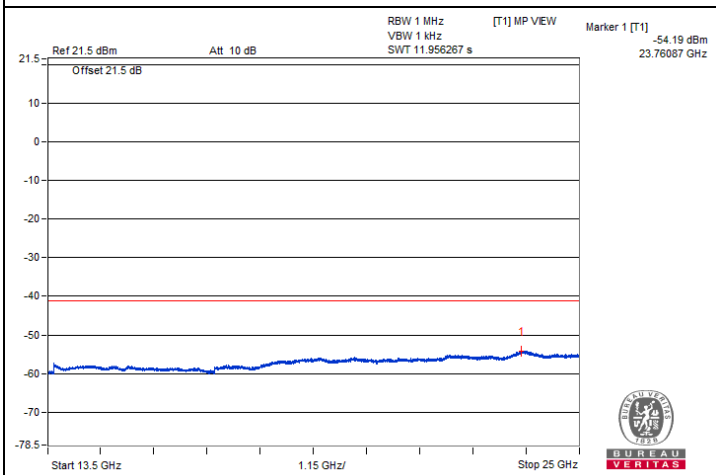
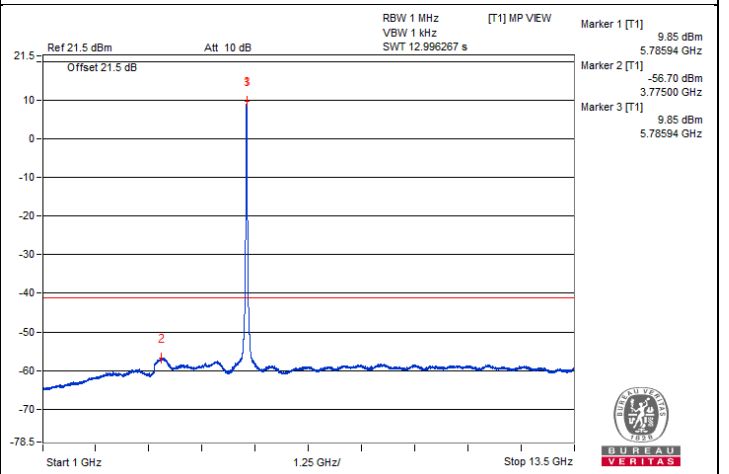
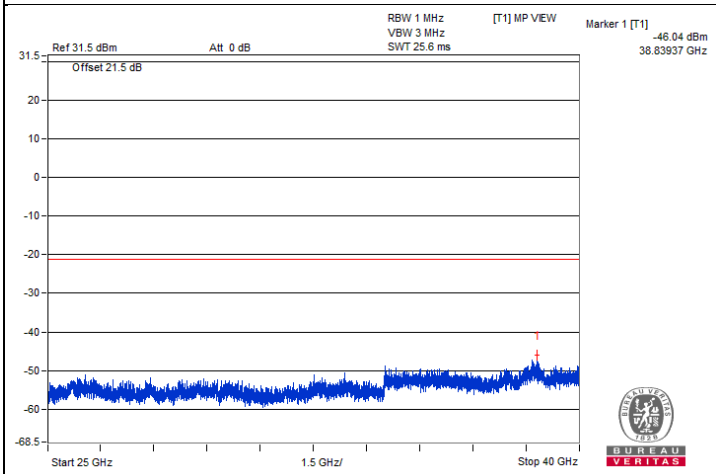
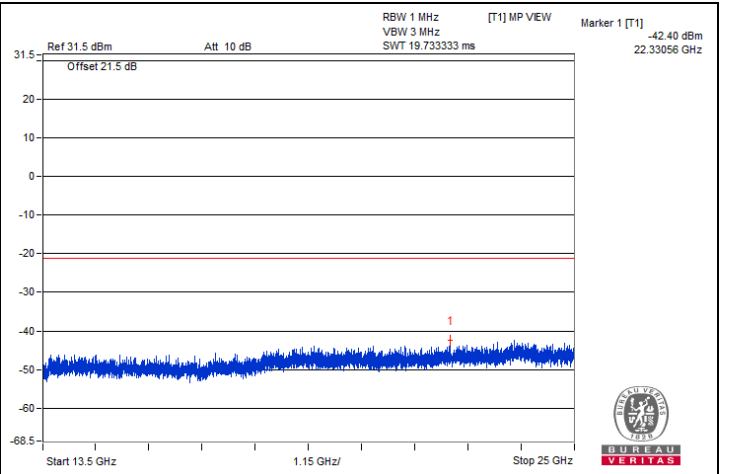
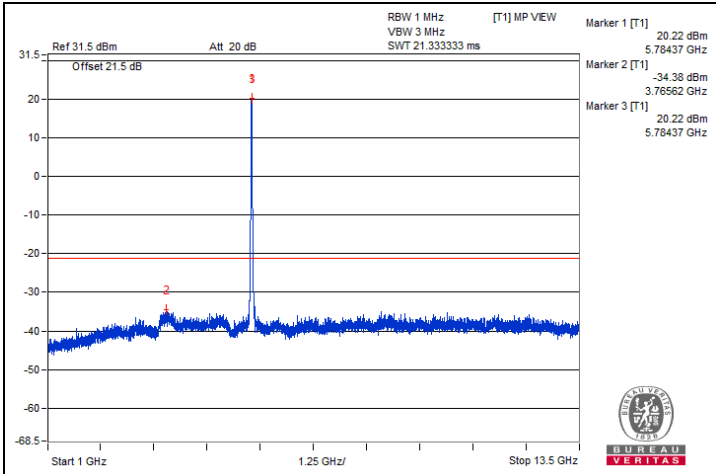



Bandedge table

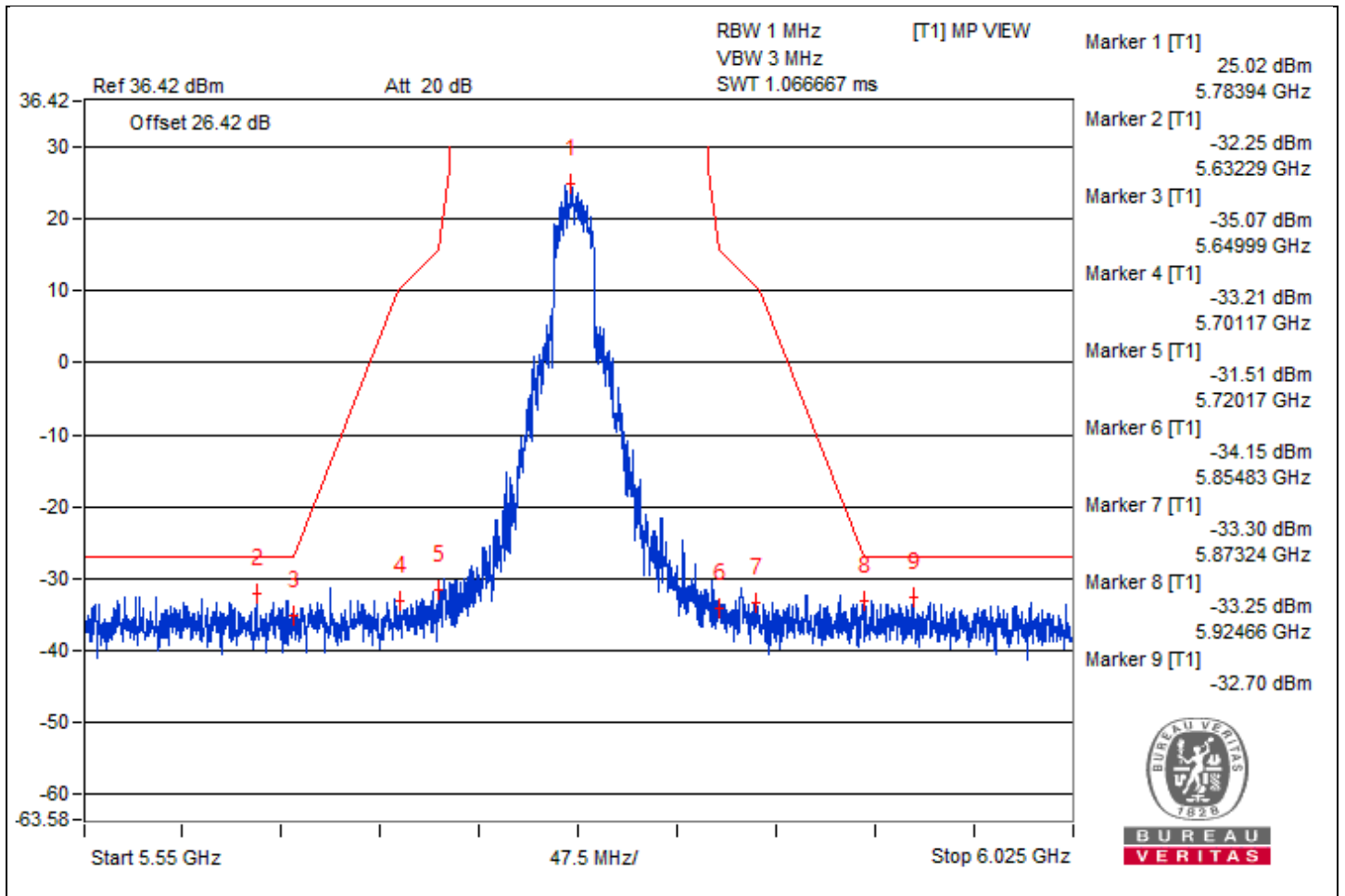

802.11be (EHT20) - Channel 165
Conducted spurious emission table

No.	Frequency (MHz)	Emission Level (dBuV/m)	Limit (dBuV/m)	Margin (dB)	Raw Value (dBm)	Correction Factor (dB)	EIRP Level (dBm)
1	3867.19	66.05 PK	74	-7.95	-34.13	4.92	-29.21
2	3865.62	42.86 AV	54	-11.14	-57.32	4.92	-52.40
3	#7760.94	62.78 PK	68.2	-5.42	-37.4	4.92	-32.48
4	11640.62	62.95 PK	74	-11.05	-37.23	4.92	-32.31
5	11634.37	40.99 AV	54	-13.01	-59.19	4.92	-54.27
6	#17463.19	53.21 PK	68.2	-14.99	-46.97	4.92	-42.05

Remarks:

1. Margin value = Emission Level – Limit value
2. The other emission levels were very low against the limit.
3. " # " : The frequency is out of the restricted band.

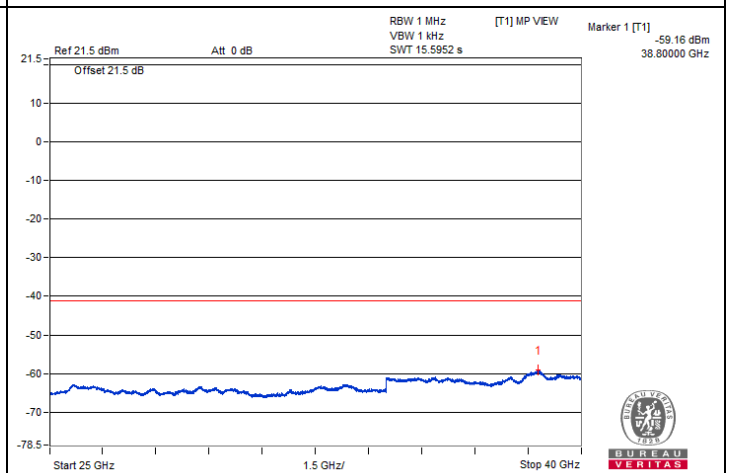
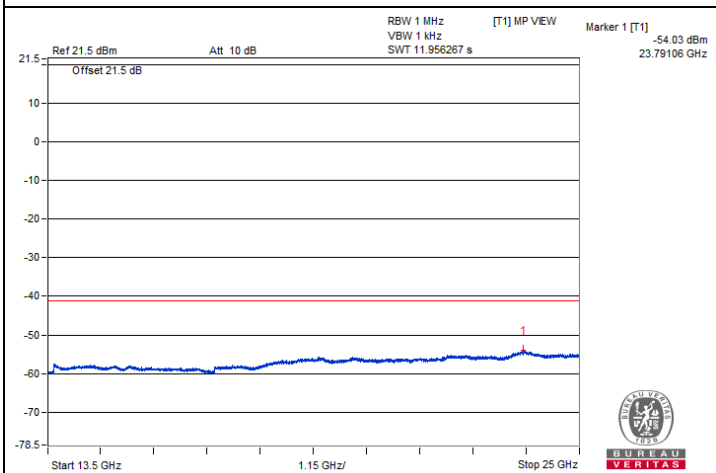
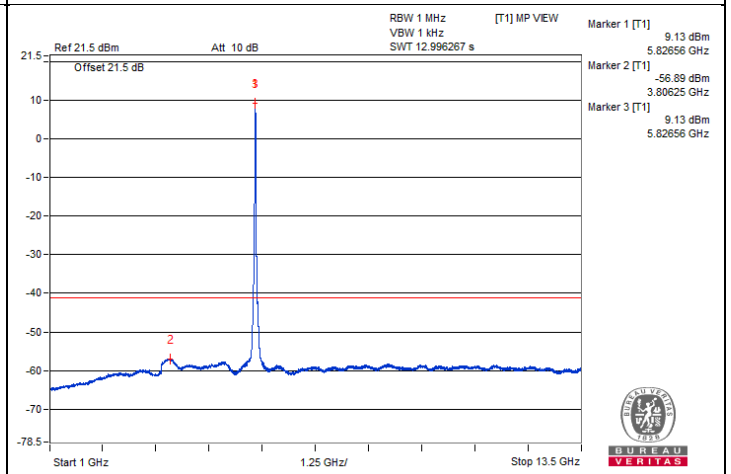
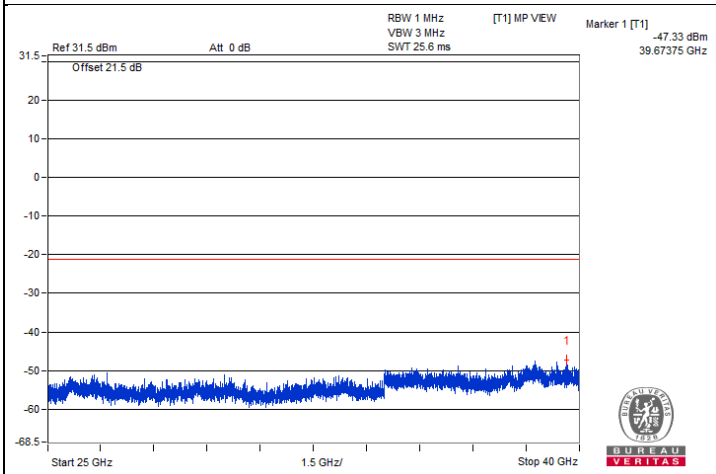
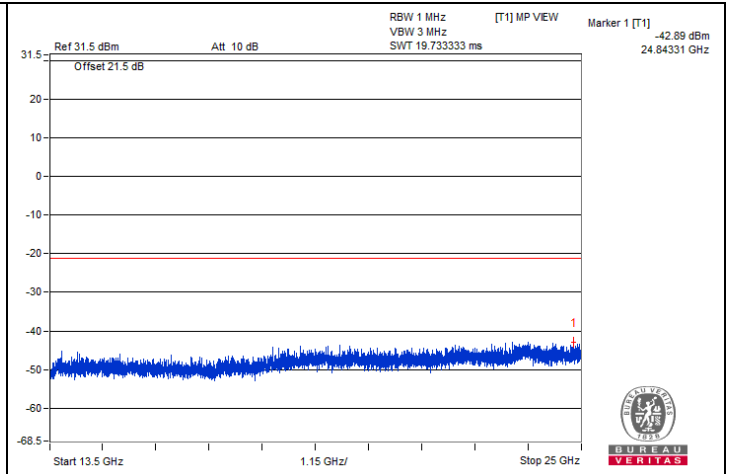
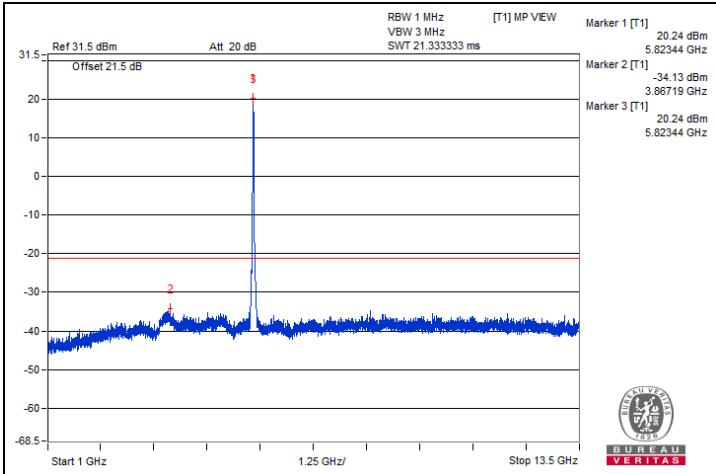

Bandedge table

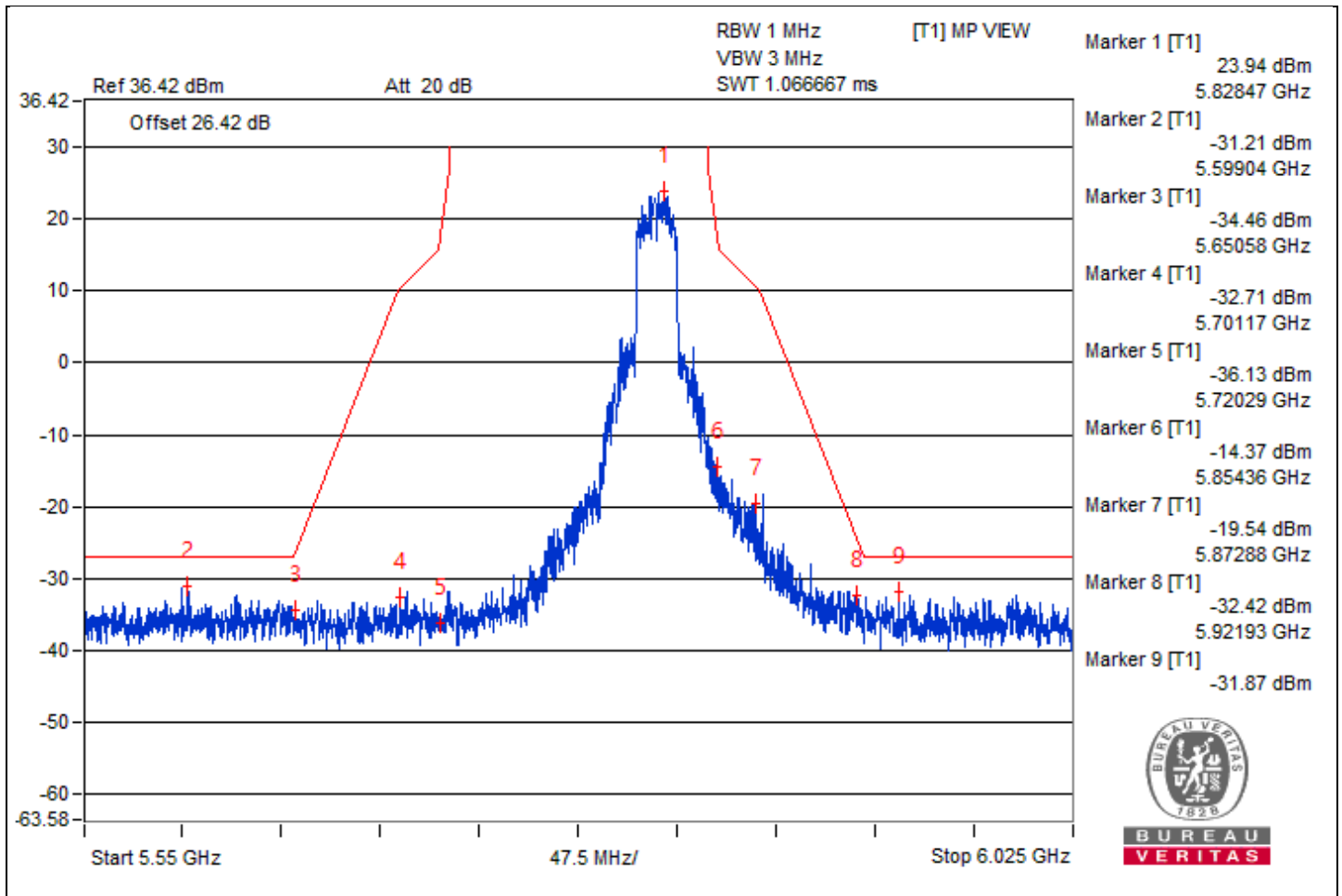

802.11be (EHT40) - Channel 38

Conducted spurious emission table

No.	Frequency (MHz)	Emission Level (dBuV/m)	Limit (dBuV/m)	Margin (dB)	Raw Value (dBm)	Correction Factor (dB)	EIRP Level (dBm)
1	#3471.87	61.25 PK	68.2	-6.95	-38.93	4.92	-34.01
2	#6939.06	62.19 PK	68.2	-6.01	-37.99	4.92	-33.07
3	#10371.87	62.35 PK	68.2	-5.85	-37.83	4.92	-32.91
4	15555.62	51.01 PK	74	-22.99	-49.17	4.92	-44.25
5	15570	41.27 AV	54	-12.73	-58.91	4.92	-53.99

Remarks:

1. Margin value = Emission Level – Limit value
2. The other emission levels were very low against the limit.
3. " # " : The frequency is out of the restricted band.

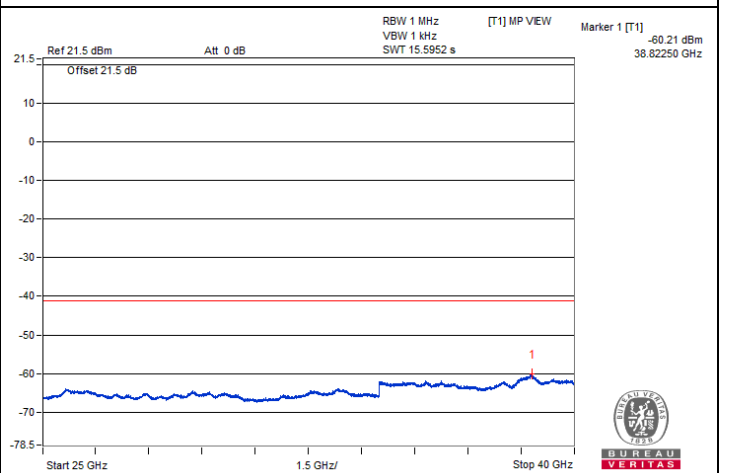
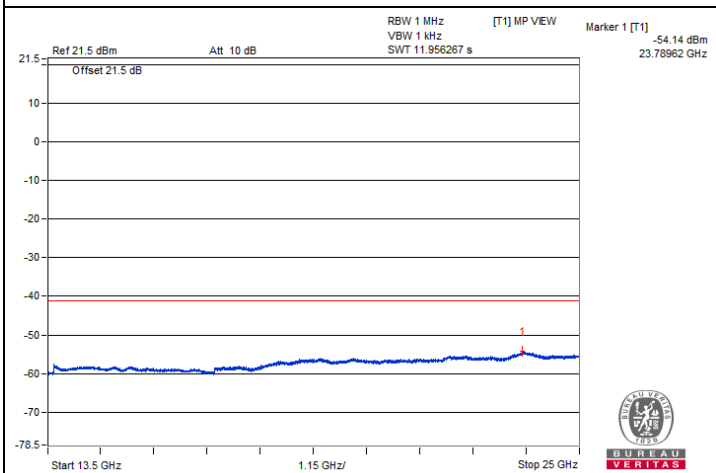
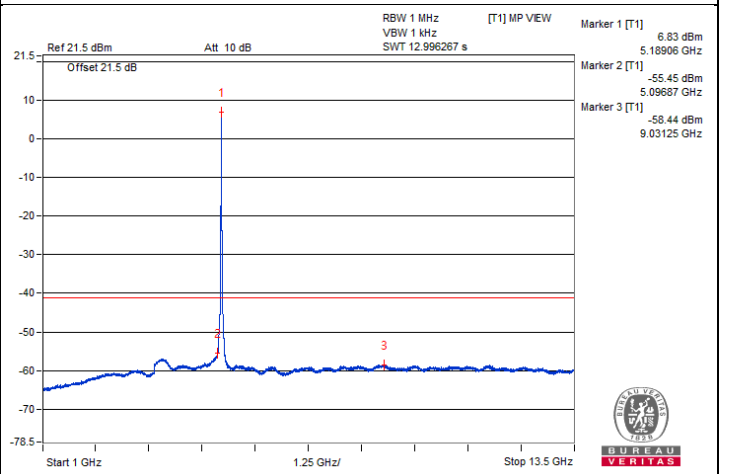
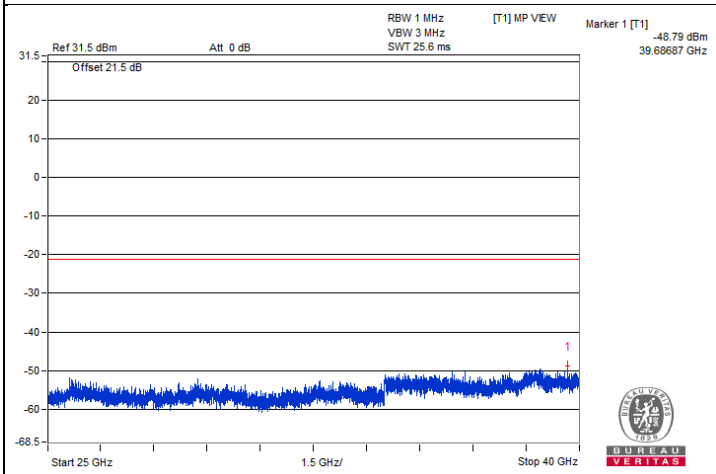
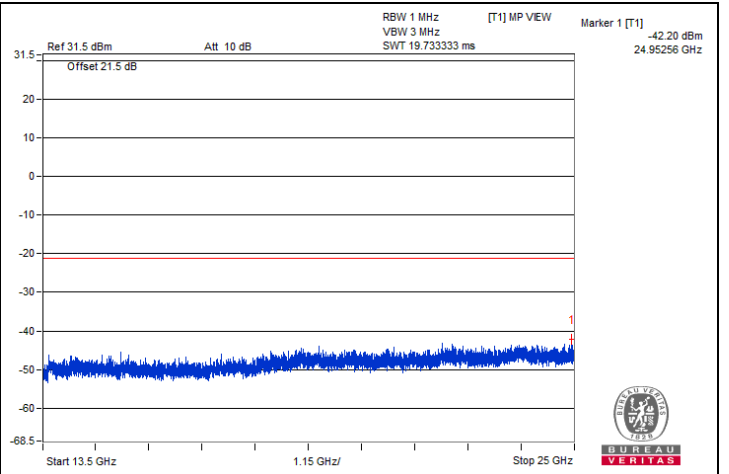
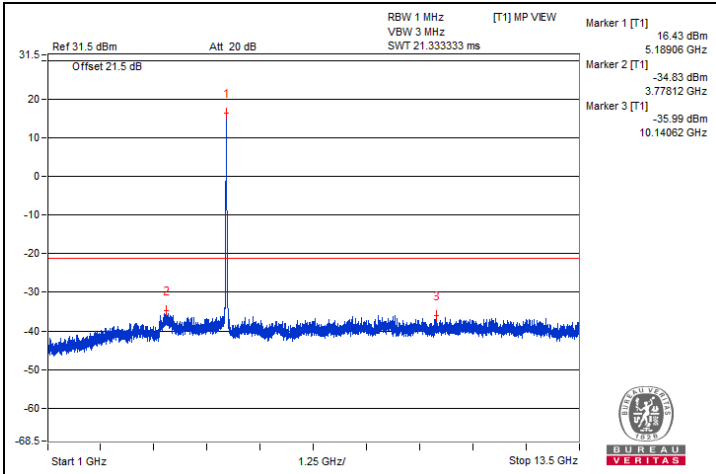

Bandedge table

No.	Frequency (MHz)	Emission Level (dBuV/m)	Limit (dBuV/m)	Margin (dB)	Raw Value (dBm)	Correction Factor (dB)	EIRP Level (dBm)
1	5149.23	66.62 PK	74	-7.38	-33.56	4.92	-28.64
2	5149.93	53.83 AV	54	-0.17	-46.35	4.92	-41.43

Remarks:

1. Margin value = Emission Level – Limit value
2. The other emission levels were very low against the limit.

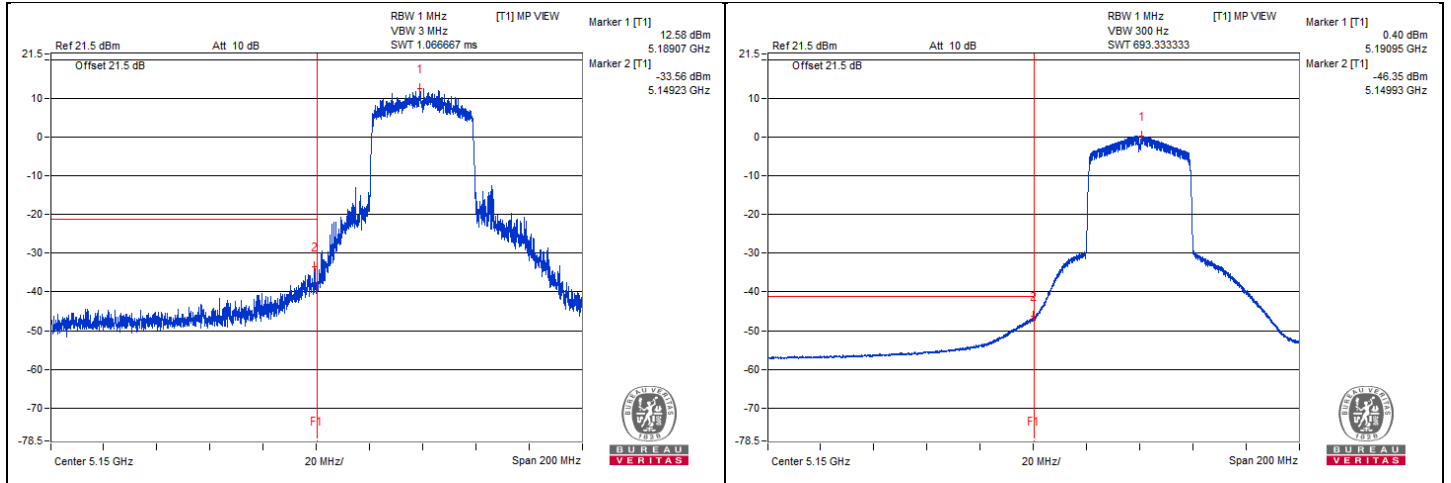

802.11be (EHT40) - Channel 46

Conducted spurious emission table

No.	Frequency (MHz)	Emission Level (dBuV/m)	Limit (dBuV/m)	Margin (dB)	Raw Value (dBm)	Correction Factor (dB)	EIRP Level (dBm)
1	#3479.69	62.2 PK	68.2	-6	-37.98	4.92	-33.06
2	#6981.25	63.2 PK	68.2	-5	-36.98	4.92	-32.06
3	#10456.25	62.97 PK	68.2	-5.23	-37.21	4.92	-32.29
4	15689.31	52.74 PK	74	-21.26	-47.44	4.92	-42.52
5	15695.06	41.74 AV	54	-12.26	-58.44	4.92	-53.52

Remarks:

1. Margin value = Emission Level – Limit value
2. The other emission levels were very low against the limit.
3. " # " : The frequency is out of the restricted band.

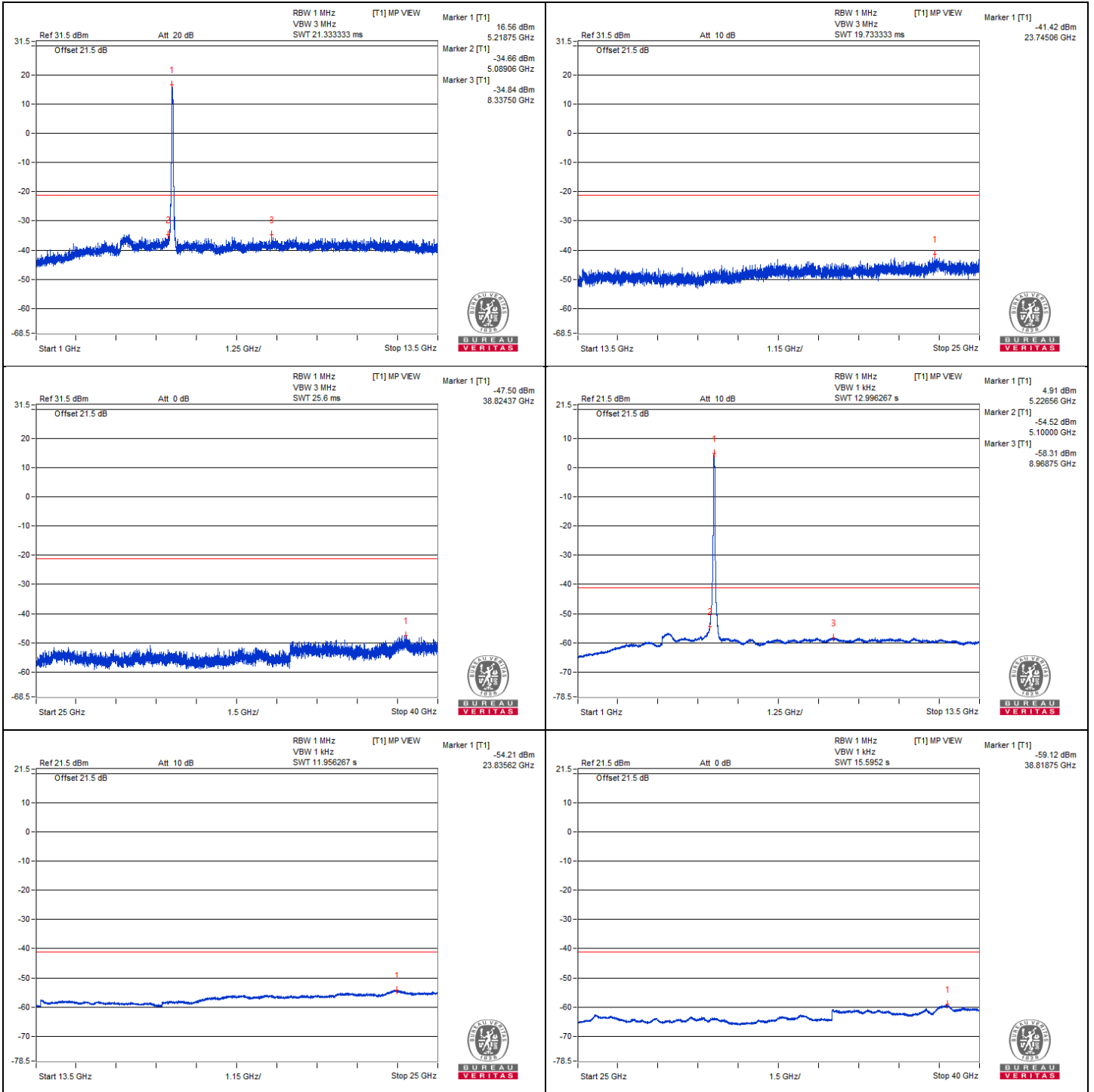

Bandedge table

No.	Frequency (MHz)	Emission Level (dBuV/m)	Limit (dBuV/m)	Margin (dB)	Raw Value (dBm)	Correction Factor (dB)	EIRP Level (dBm)
1	5394.98	62.01 PK	74	-11.99	-38.17	4.92	-33.25
2	5350	50.13 AV	54	-3.87	-50.05	4.92	-45.13

Remarks:

1. Margin value = Emission Level – Limit value
2. The other emission levels were very low against the limit.

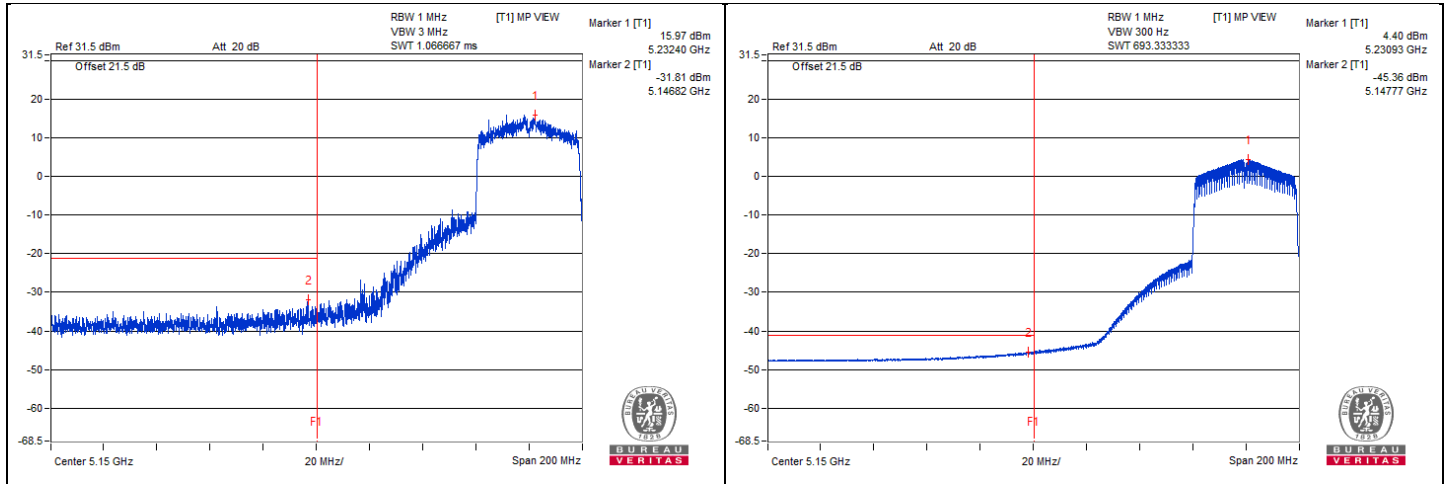

802.11be (EHT40) - Channel 54

Conducted spurious emission table

No.	Frequency (MHz)	Emission Level (dBuV/m)	Limit (dBuV/m)	Margin (dB)	Raw Value (dBm)	Correction Factor (dB)	EIRP Level (dBm)
1	3517.19	60.92 PK	74	-13.08	-39.26	4.92	-34.34
2	3520.31	39.32 AV	54	-14.68	-60.86	4.92	-55.94
3	#7012.5	63.62 PK	68.2	-4.58	-36.56	4.92	-31.64
4	#10531.25	62.76 PK	68.2	-5.44	-37.42	4.92	-32.50
5	15818.69	51.04 PK	74	-22.96	-49.14	4.92	-44.22
6	15808.62	41.52 AV	54	-12.48	-58.66	4.92	-53.74

Remarks:

1. Margin value = Emission Level – Limit value
2. The other emission levels were very low against the limit.
3. " # " : The frequency is out of the restricted band.

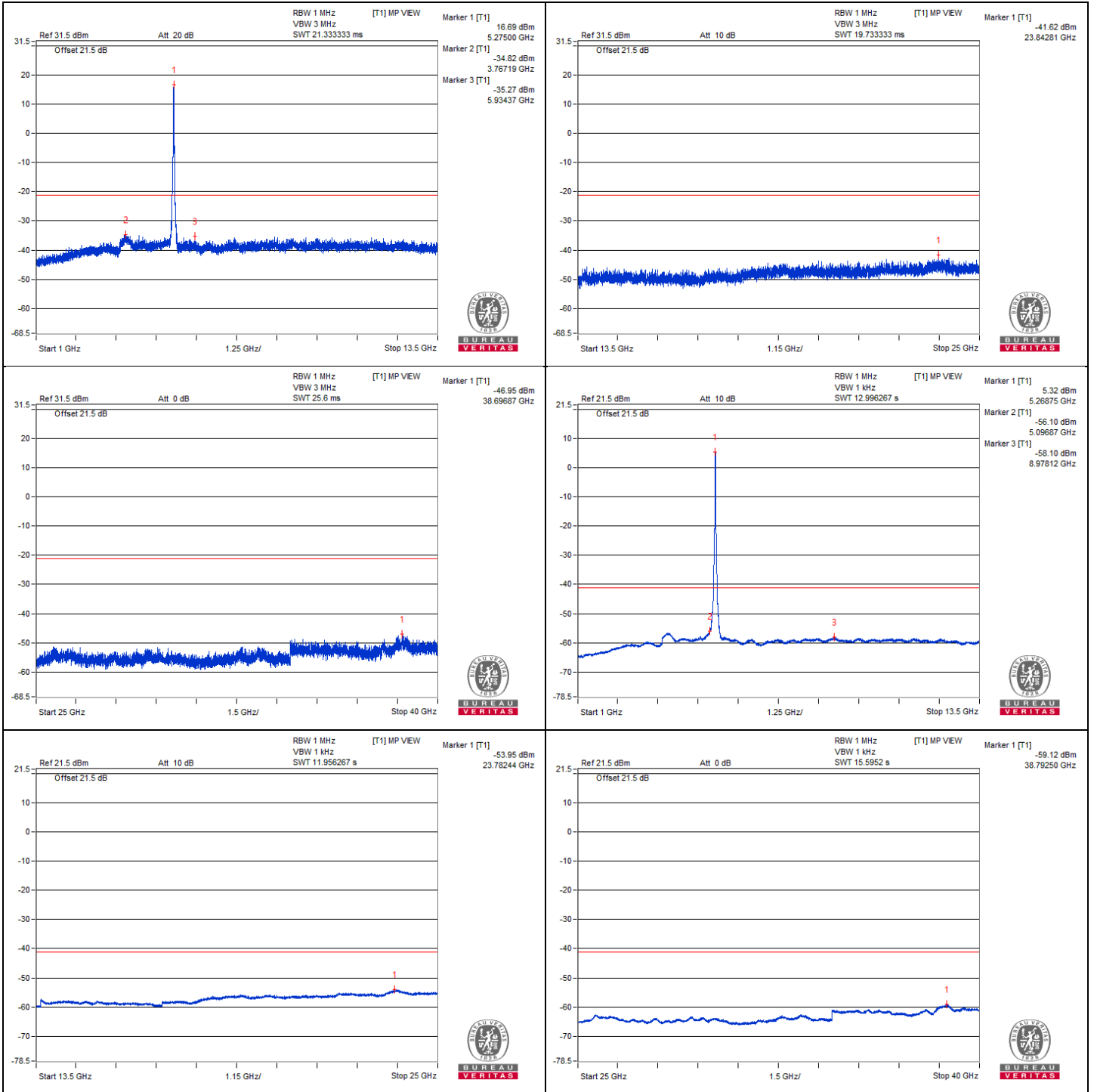

Bandedge table

No.	Frequency (MHz)	Emission Level (dBuV/m)	Limit (dBuV/m)	Margin (dB)	Raw Value (dBm)	Correction Factor (dB)	EIRP Level (dBm)
1	5358.52	68.06 PK	74	-5.94	-32.12	4.92	-27.20
2	5350.1	55.87 AV	54	-0.13	-46.31	4.92	-39.39

Remarks:

1. Margin value = Emission Level – Limit value
2. The other emission levels were very low against the limit.

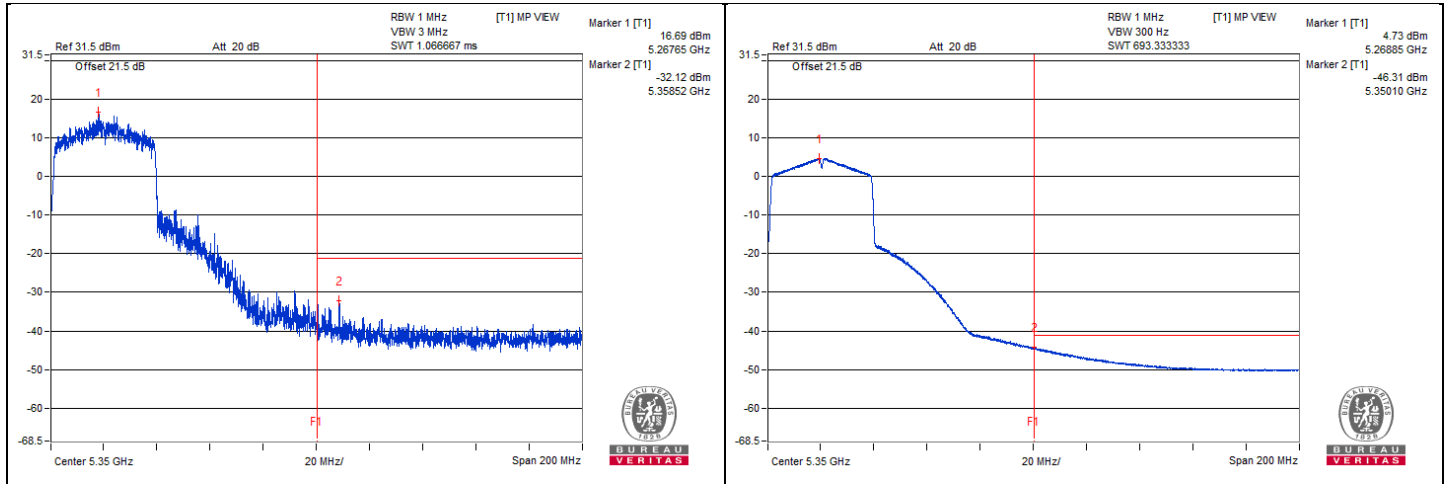

802.11be (EHT40) - Channel 62
Conducted spurious emission table

No.	Frequency (MHz)	Emission Level (dBuV/m)	Limit (dBuV/m)	Margin (dB)	Raw Value (dBm)	Correction Factor (dB)	EIRP Level (dBm)
1	3554.69	61.44 PK	74	-12.56	-38.74	4.92	-33.82
2	3557.81	39.44 AV	54	-14.56	-60.74	4.92	-55.82
3	#7076.56	64.24 PK	68.2	-3.96	-35.94	4.92	-31.02
4	10617.19	63.5 PK	74	-10.5	-36.68	4.92	-31.76
5	10628.12	41.51 AV	54	-12.49	-58.67	4.92	-53.75
6	15926.5	52.12 PK	74	-21.88	-48.06	4.92	-43.14
7	15929.37	41.63 AV	54	-12.37	-58.55	4.92	-53.63

Remarks:

1. Margin value = Emission Level – Limit value
2. The other emission levels were very low against the limit.
3. " # " : The frequency is out of the restricted band.

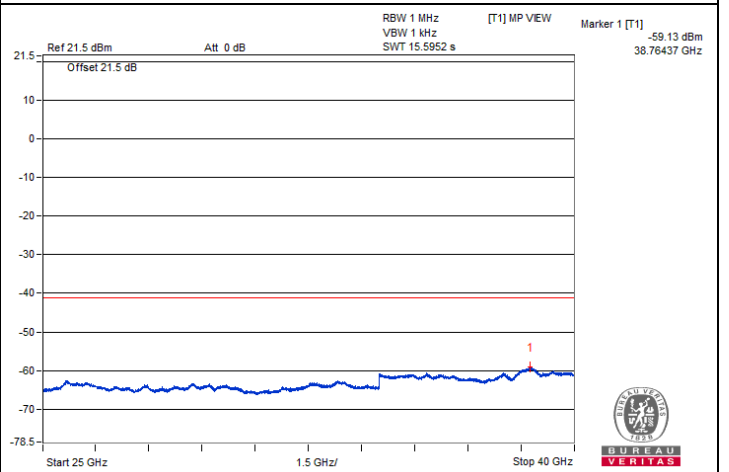
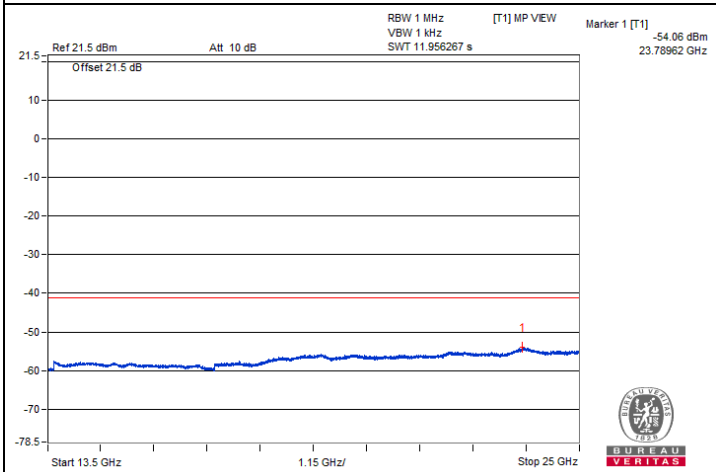
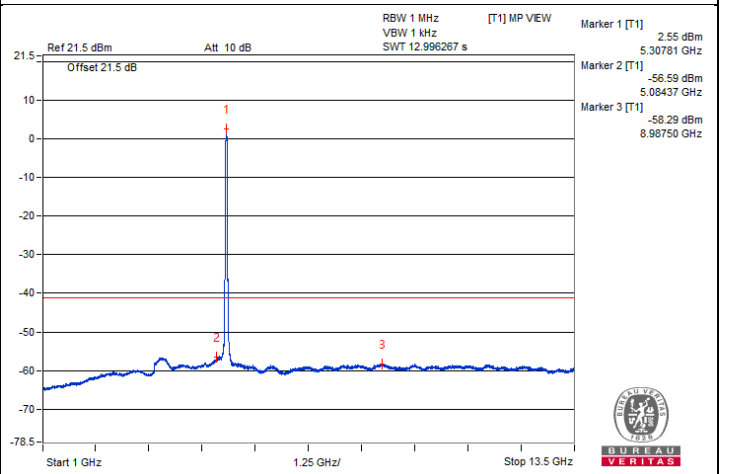
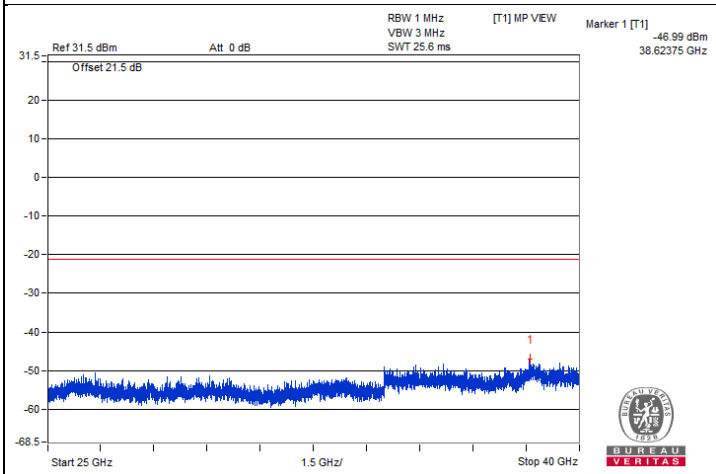
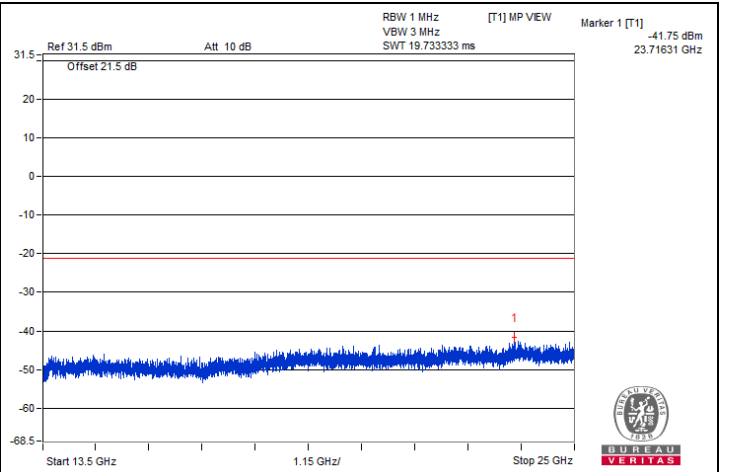
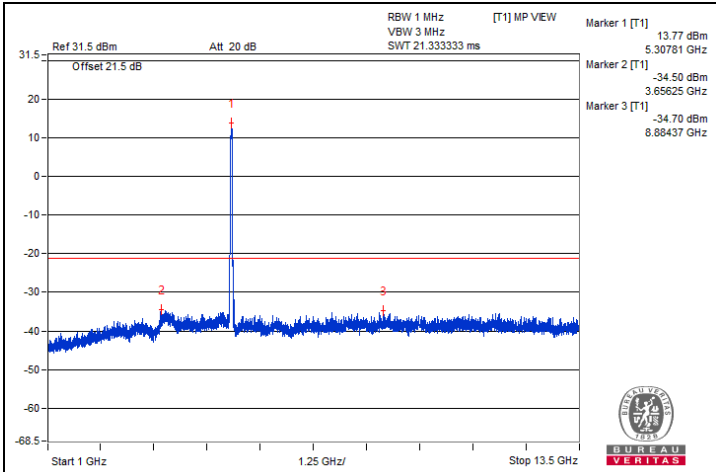

Bandedge table

No.	Frequency (MHz)	Emission Level (dBuV/m)	Limit (dBuV/m)	Margin (dB)	Raw Value (dBm)	Correction Factor (dB)	EIRP Level (dBm)
1	5372.1	65.57 PK	74	-8.43	-34.61	4.92	-29.69
2	5350	52.72 AV	54	-1.28	-47.46	4.92	-42.54

Remarks:

1. Margin value = Emission Level – Limit value
2. The other emission levels were very low against the limit.

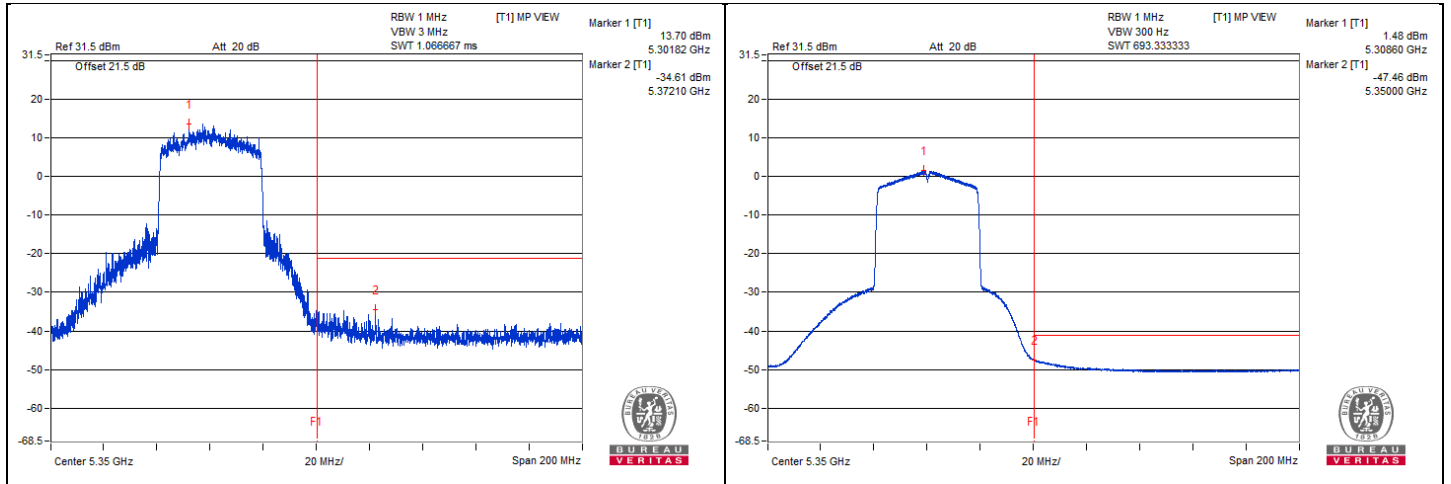

802.11be (EHT80) - Channel 106

Conducted spurious emission table

No.	Frequency (MHz)	Emission Level (dBuV/m)	Limit (dBuV/m)	Margin (dB)	Raw Value (dBm)	Correction Factor (dB)	EIRP Level (dBm)
1	3698.44	65.04 PK	74	-8.96	-35.14	4.92	-30.22
2	3685.94	42.73 AV	54	-11.27	-57.45	4.92	-52.53
3	7362.5	61.29 PK	74	-12.71	-38.89	4.92	-33.97
4	7357.81	40.46 AV	54	-13.54	-59.72	4.92	-54.80
5	11045.31	62.77 PK	74	-11.23	-37.41	4.92	-32.49
6	11054.69	41.34 AV	54	-12.66	-58.84	4.92	-53.92
7	#16590.62	51.79 PK	68.2	-16.41	-48.39	4.92	-43.47

Remarks:

1. Margin value = Emission Level – Limit value
2. The other emission levels were very low against the limit.
3. " # " : The frequency is out of the restricted band.

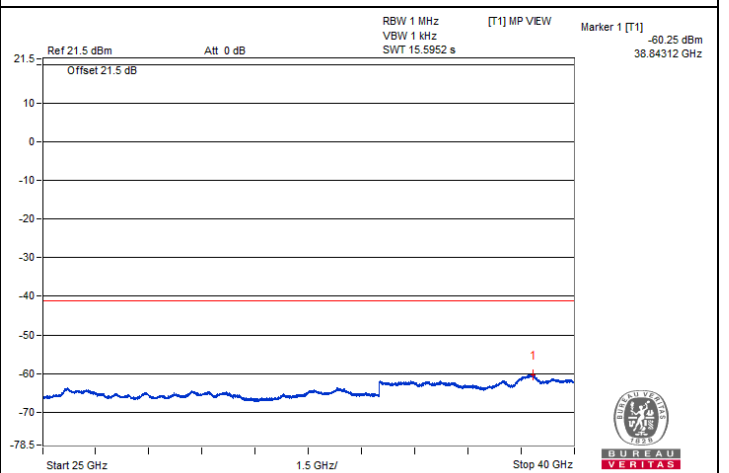
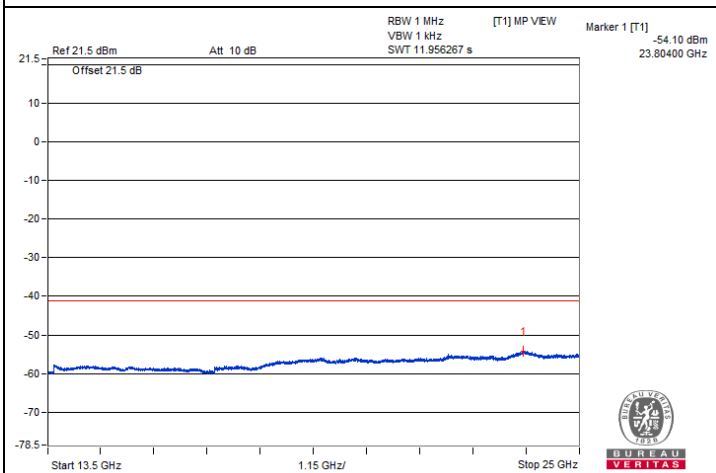
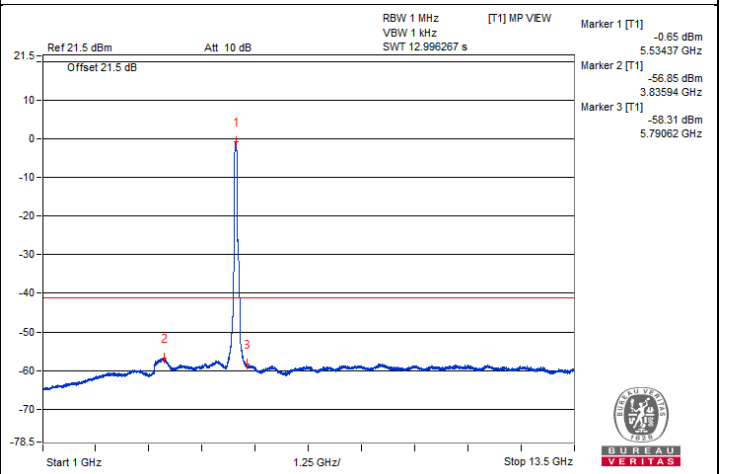
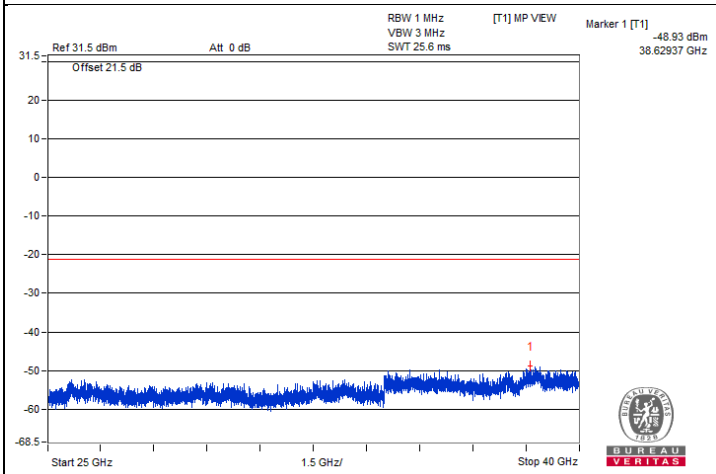
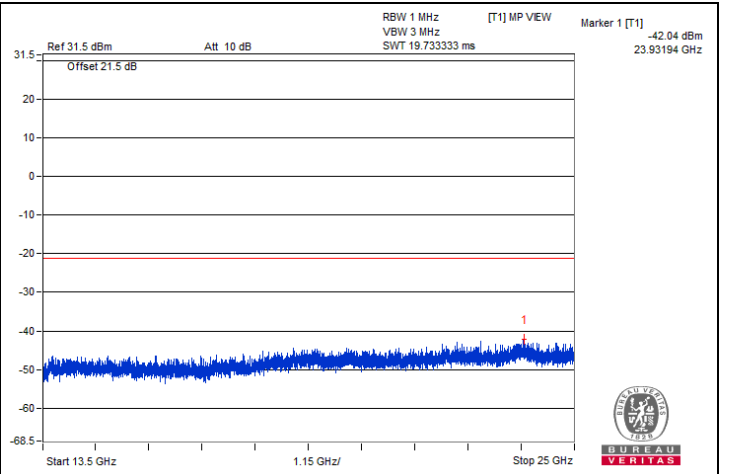
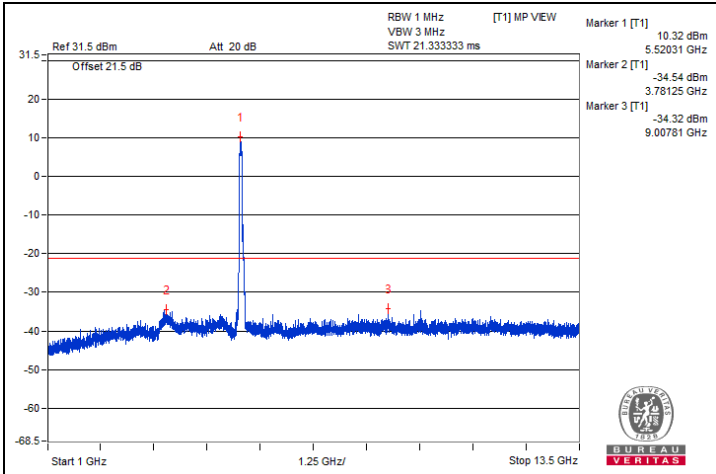

Bandedge table

No.	Frequency (MHz)	Emission Level (dBUV/m)	Limit (dBUV/m)	Margin (dB)	Raw Value (dBm)	Correction Factor (dB)	EIRP Level (dBm)
1	5457.09	66.56 PK	74	-7.44	-33.62	4.92	-28.70
2	5457.22	53.62 AV	54	-0.38	-46.56	4.92	-41.64
3	#5468.97	65.94 PK	68.2	-2.26	-34.24	4.92	-29.32

Remarks:

1. Margin value = Emission Level – Limit value
2. The other emission levels were very low against the limit.

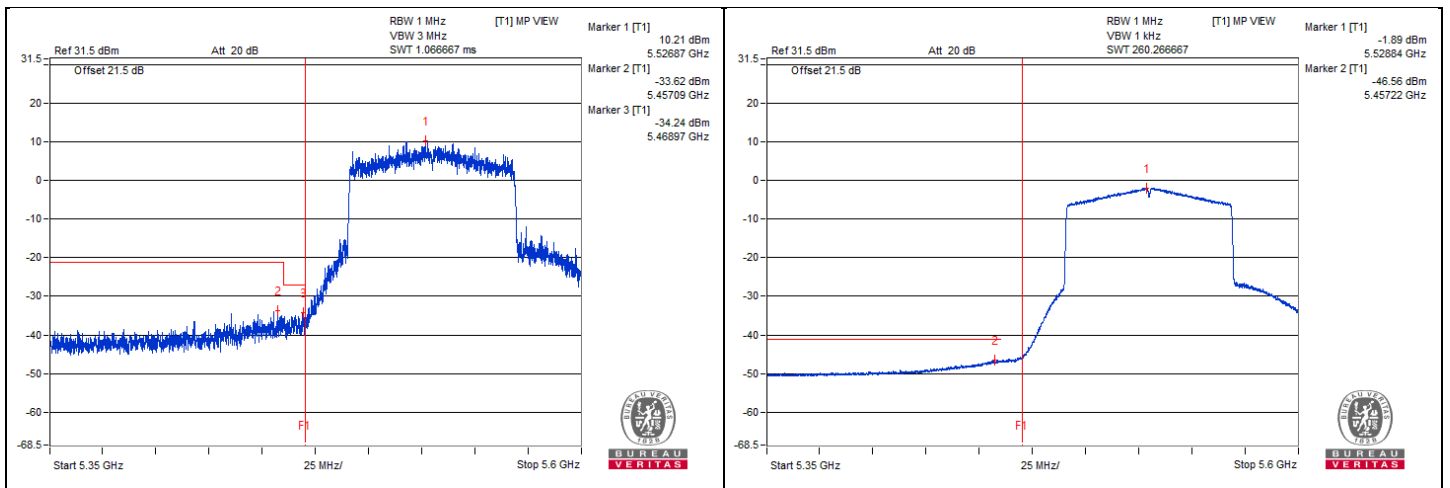

802.11be (EHT80) - Channel 122

Conducted spurious emission table

No.	Frequency (MHz)	Emission Level (dBuV/m)	Limit (dBuV/m)	Margin (dB)	Raw Value (dBm)	Correction Factor (dB)	EIRP Level (dBm)
1	3723.44	64 PK	74	-10	-36.18	4.92	-31.26
2	3739.06	43.4 AV	54	-10.6	-56.78	4.92	-51.86
3	7481.25	61.42 PK	74	-12.58	-38.76	4.92	-33.84
4	7498.44	40.39 AV	54	-13.61	-59.79	4.92	-54.87
5	11204.69	62.36 PK	74	-11.64	-37.82	4.92	-32.90
6	11214.06	40.85 AV	54	-13.15	-59.33	4.92	-54.41
7	#16826.37	52.22 PK	68.2	-15.98	-47.96	4.92	-43.04

Remarks:

1. Margin value = Emission Level – Limit value
2. The other emission levels were very low against the limit.
3. " # " : The frequency is out of the restricted band.

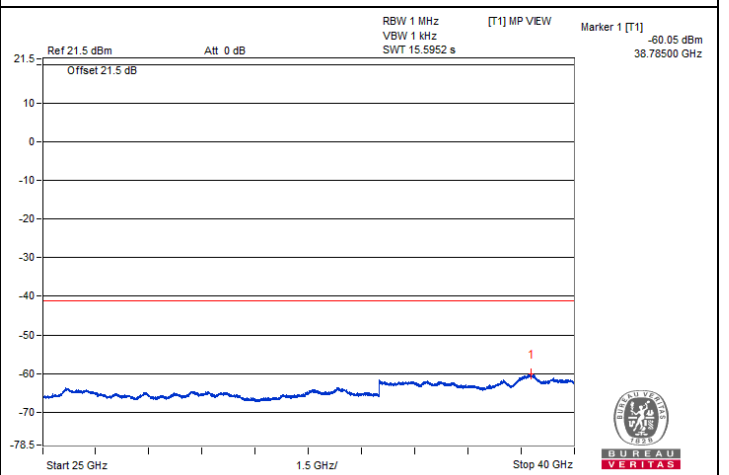
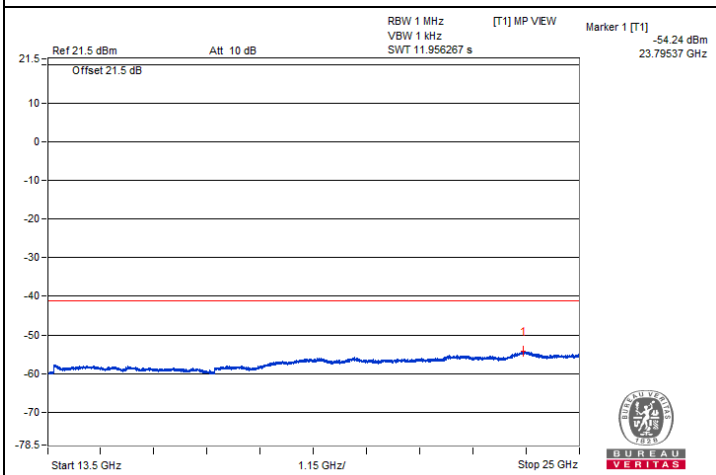
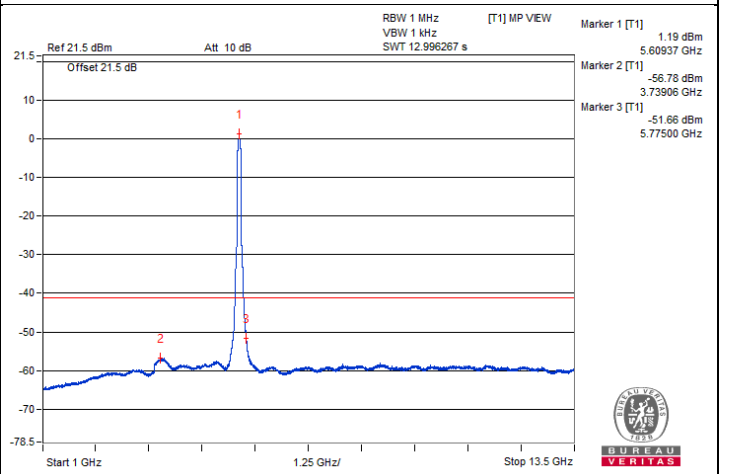
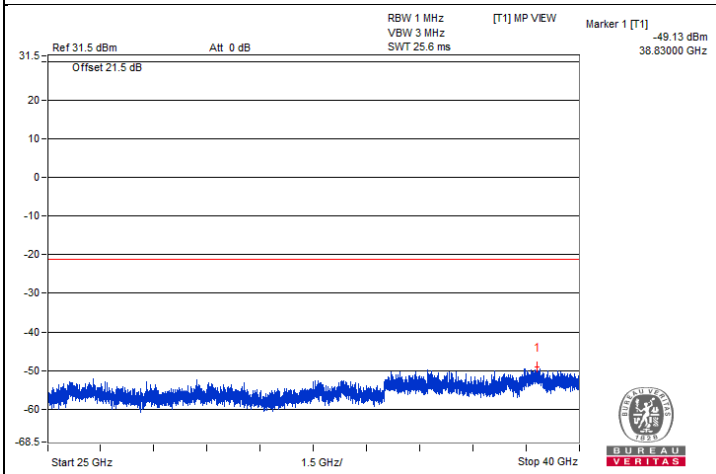
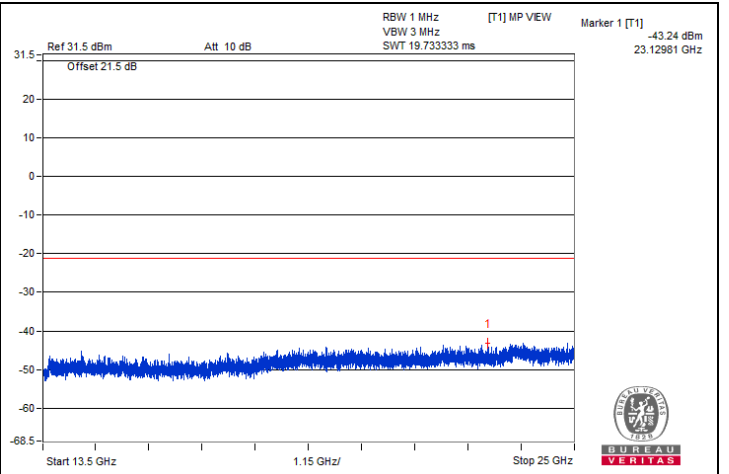
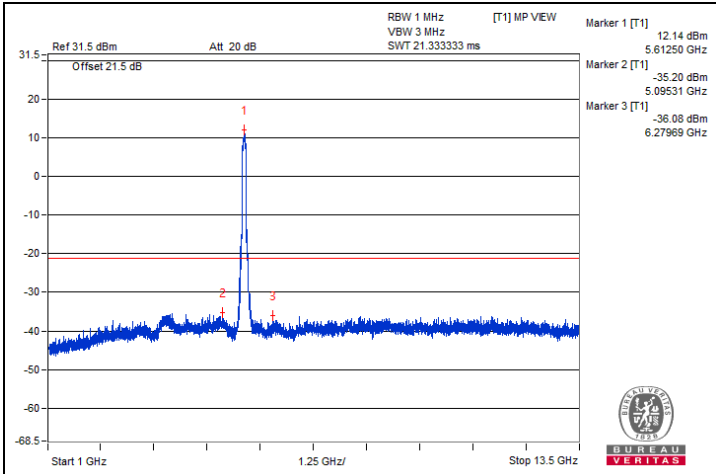

Bandedge table

No.	Frequency (MHz)	Emission Level (dBuV/m)	Limit (dBuV/m)	Margin (dB)	Raw Value (dBm)	Correction Factor (dB)	EIRP Level (dBm)
1	#5759.07	67.89 PK	68.2	-0.31	-32.29	4.92	-27.37

Remarks:

1. Margin value = Emission Level – Limit value
2. The other emission levels were very low against the limit.

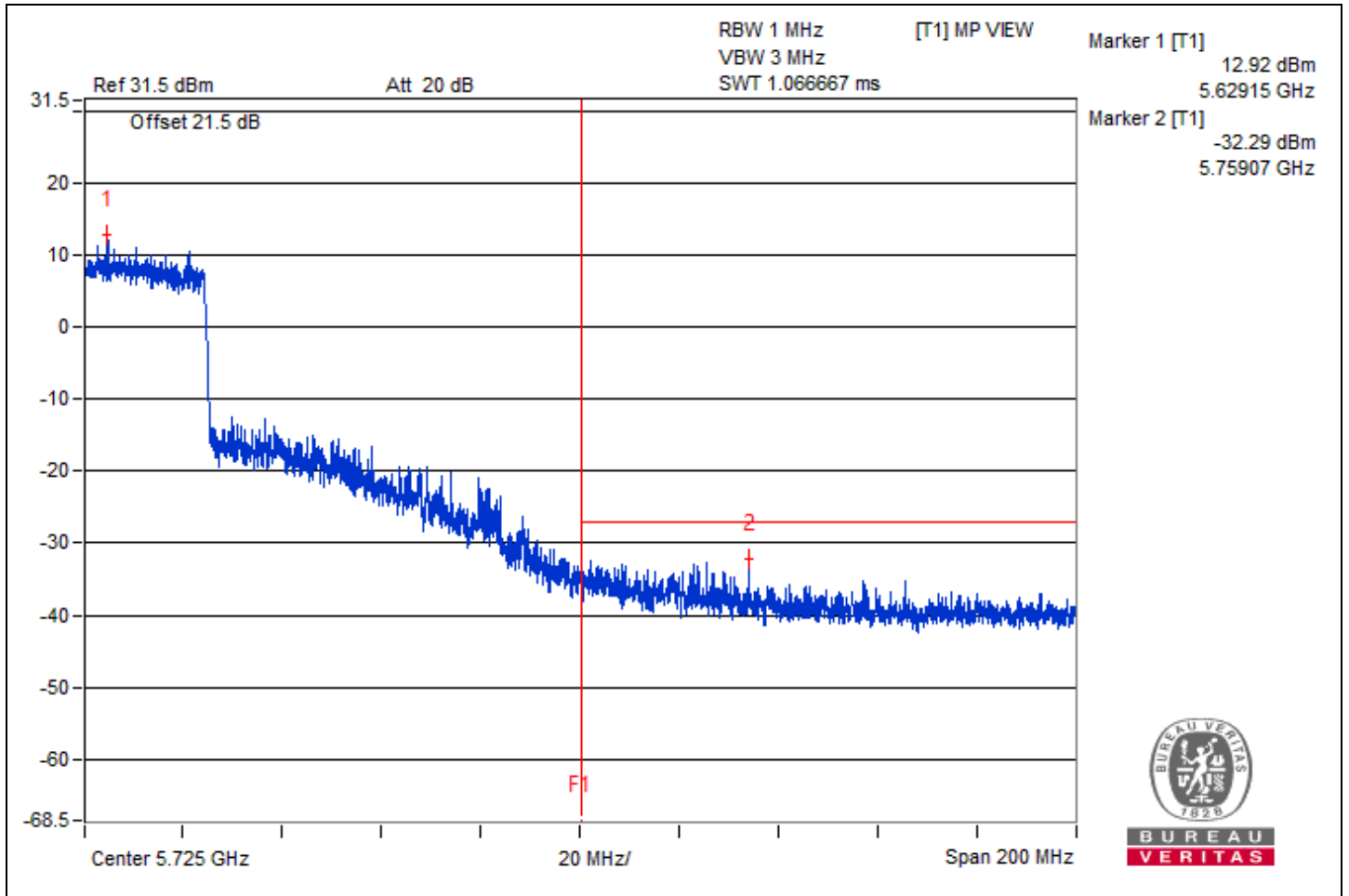

802.11be (EHT80) - Channel 138

Conducted spurious emission table

No.	Frequency (MHz)	Emission Level (dBuV/m)	Limit (dBuV/m)	Margin (dB)	Raw Value (dBm)	Correction Factor (dB)	EIRP Level (dBm)
1	3723.44	63.95 PK	74	-10.05	-36.23	4.92	-31.31
2	3746.87	43.16 AV	54	-10.84	-57.02	4.92	-52.10
3	7500	61.79 PK	74	-12.21	-38.39	4.92	-33.47
4	7492.19	40.56 AV	54	-13.44	-59.62	4.92	-54.70
5	11201.56	62.37 PK	74	-11.63	-37.81	4.92	-32.89
6	11217.19	41.03 AV	54	-12.97	-59.15	4.92	-54.23
7	#16826.37	50.73 PK	68.2	-17.47	-49.45	4.92	-44.53

Remarks:

1. Margin value = Emission Level – Limit value
2. The other emission levels were very low against the limit.
3. " # " : The frequency is out of the restricted band.

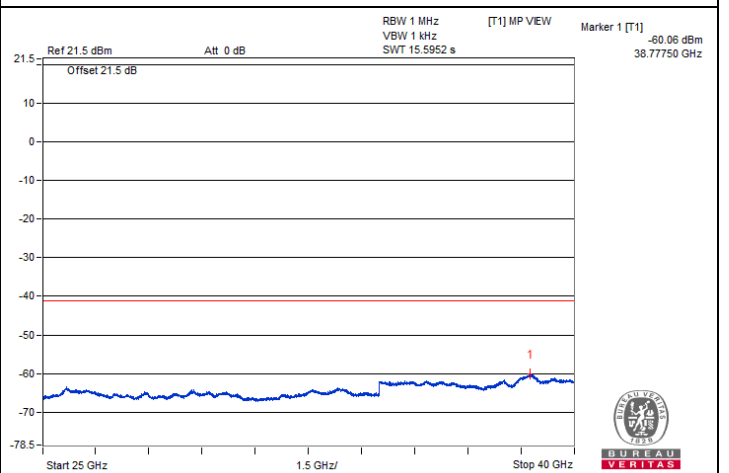
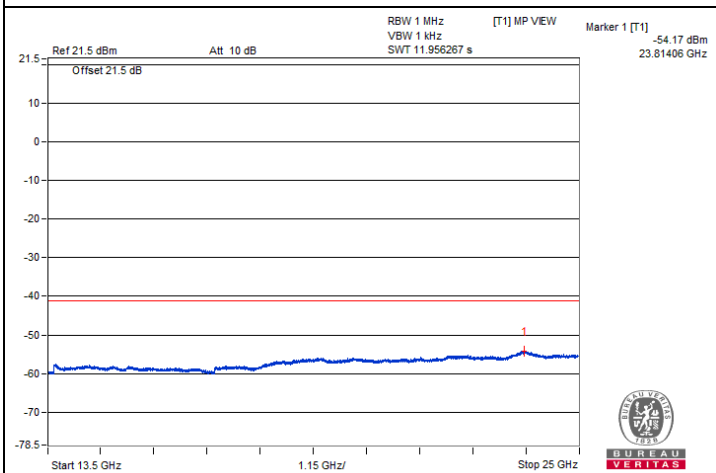
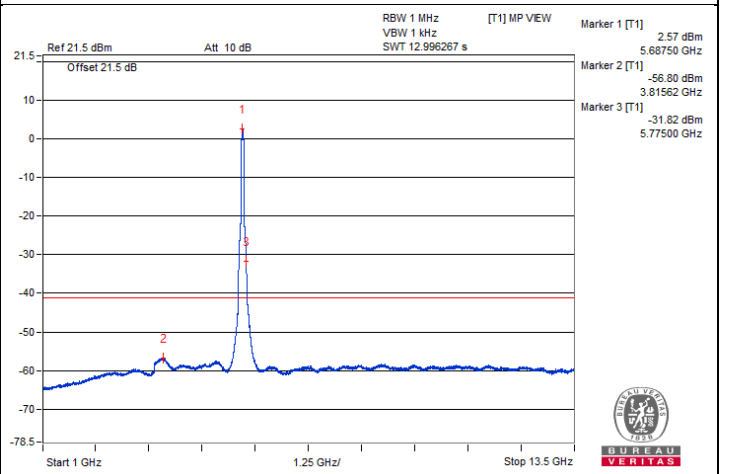
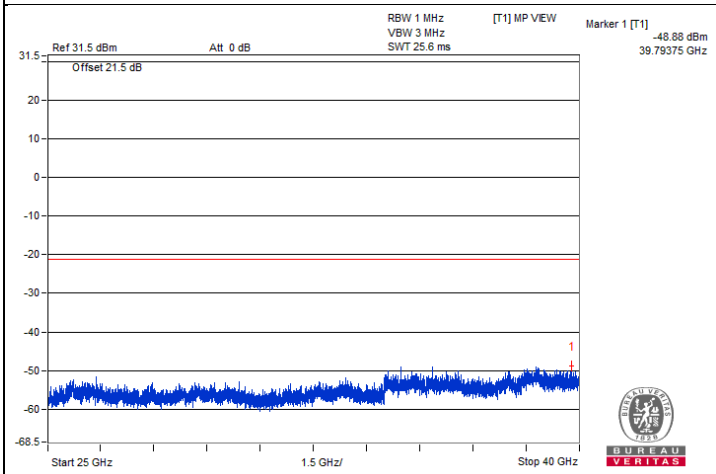
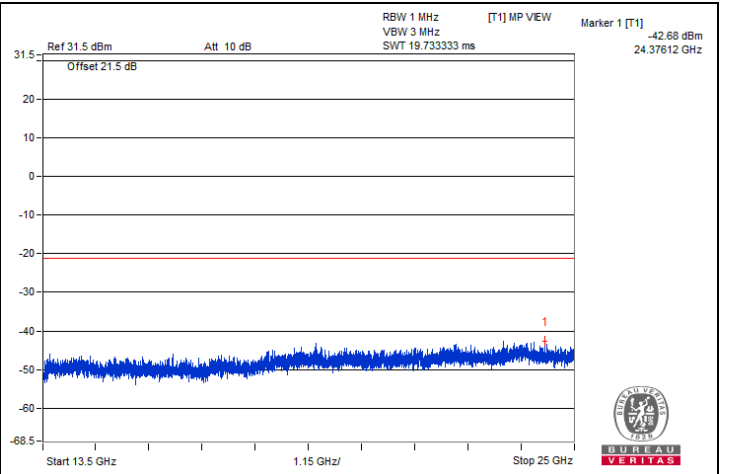
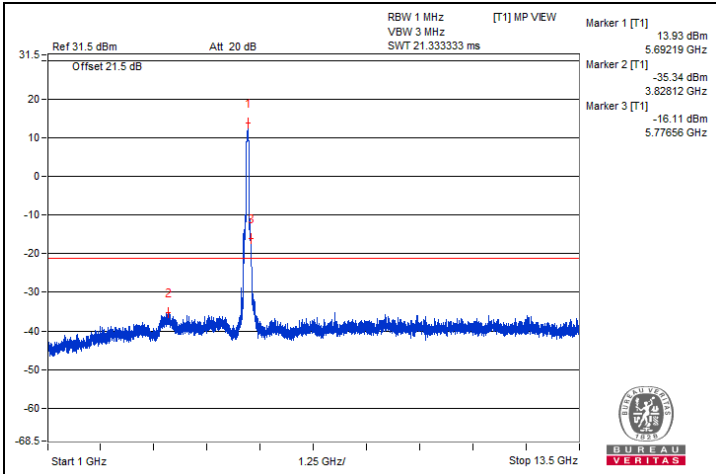

Bandedge table

No.	Frequency (MHz)	Emission Level (dBuV/m)	Limit (dBuV/m)	Margin (dB)	Raw Value (dBm)	Correction Factor (dB)	EIRP Level (dBm)
1	#5860.8	67 PK	68.2	-1.2	-33.18	4.92	-28.26

Remarks:

1. Margin value = Emission Level – Limit value
2. The other emission levels were very low against the limit.

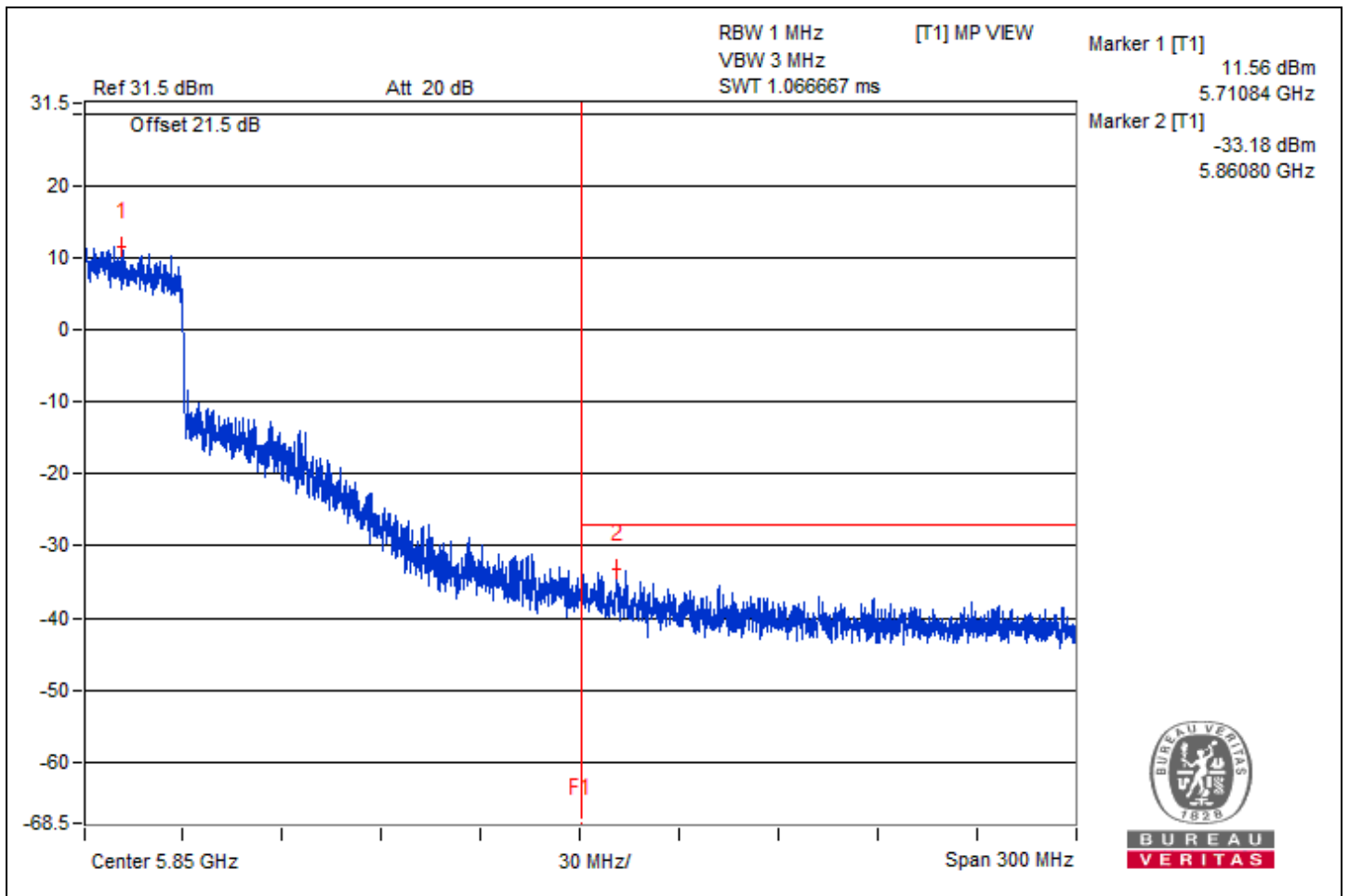

Mode A 2S2T
802.11be (EHT20) - Channel 149
Conducted spurious emission table

No.	Frequency (MHz)	Emission Level (dBuV/m)	Limit (dBuV/m)	Margin (dB)	Raw Value (dBm)		Correction Factor (dB)	EIRP Level (dBm)
					Chain0	Chain1		
1	3823.44	66.43 PK	74	-7.57	-36.76	-36.77	4.92	-28.83
2	3831.25	46.38 AV	54	-7.62	-56.89	-56.74	4.92	-48.88
3	7645.31	65.28 PK	74	-8.72	-38.61	-37.31	4.92	-29.98
4	7667.19	44.2 AV	54	-9.8	-59.05	-58.93	4.92	-51.06
5	11485.94	65.95 PK	74	-8.05	-39.01	-35.98	4.92	-29.31
6	11495.31	44.64 AV	54	-9.36	-58.66	-58.44	4.92	-50.62
7	#17223.12	54.72 PK	68.2	-13.48	-48.38	-48.56	4.92	-40.54

Remarks:

1. Margin value = Emission Level – Limit value
2. The other emission levels were very low against the limit.
3. " # " : The frequency is out of the restricted band.



Chain 0

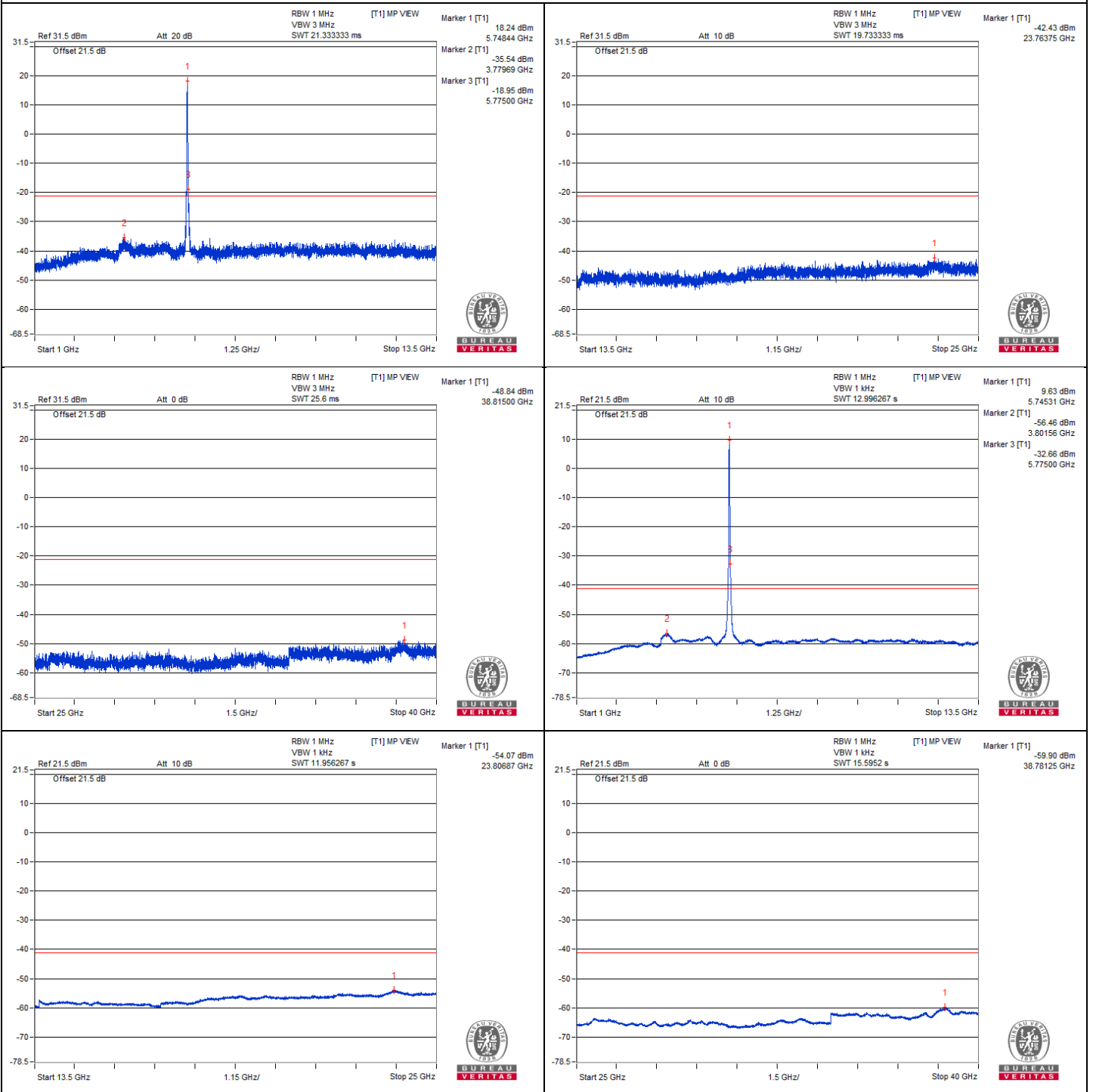



Chain 1

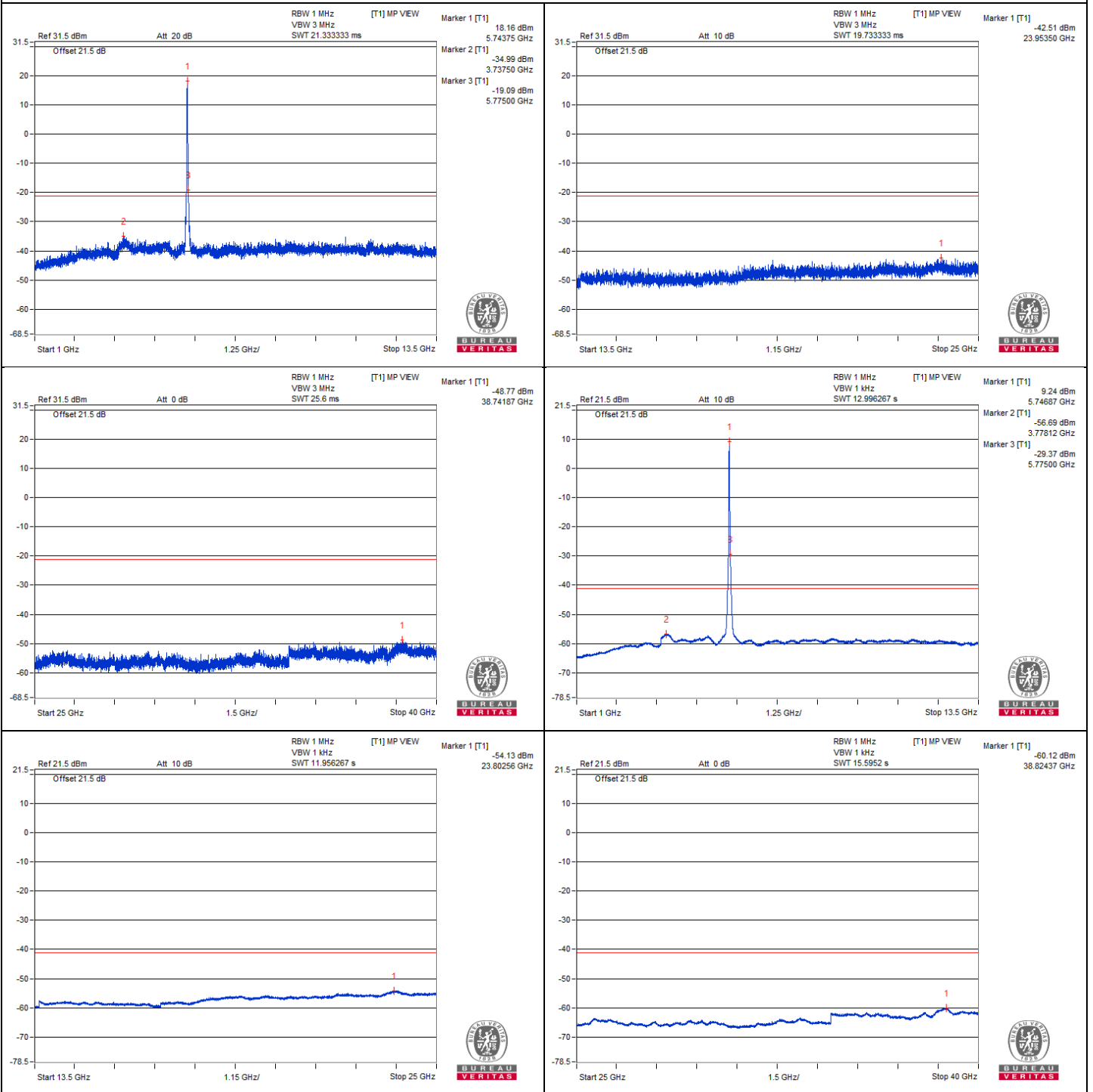



Bandedge table

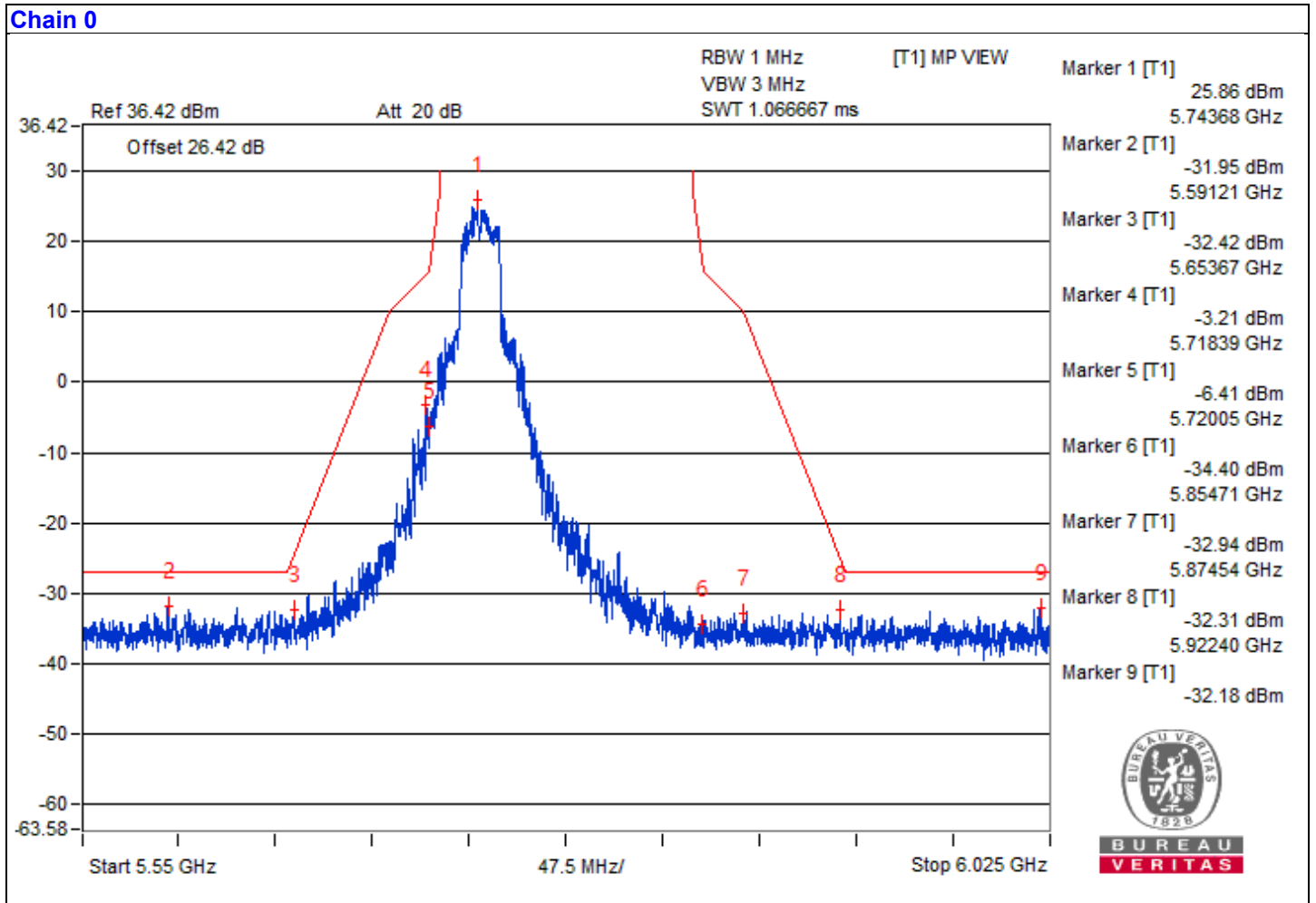



Chain 1

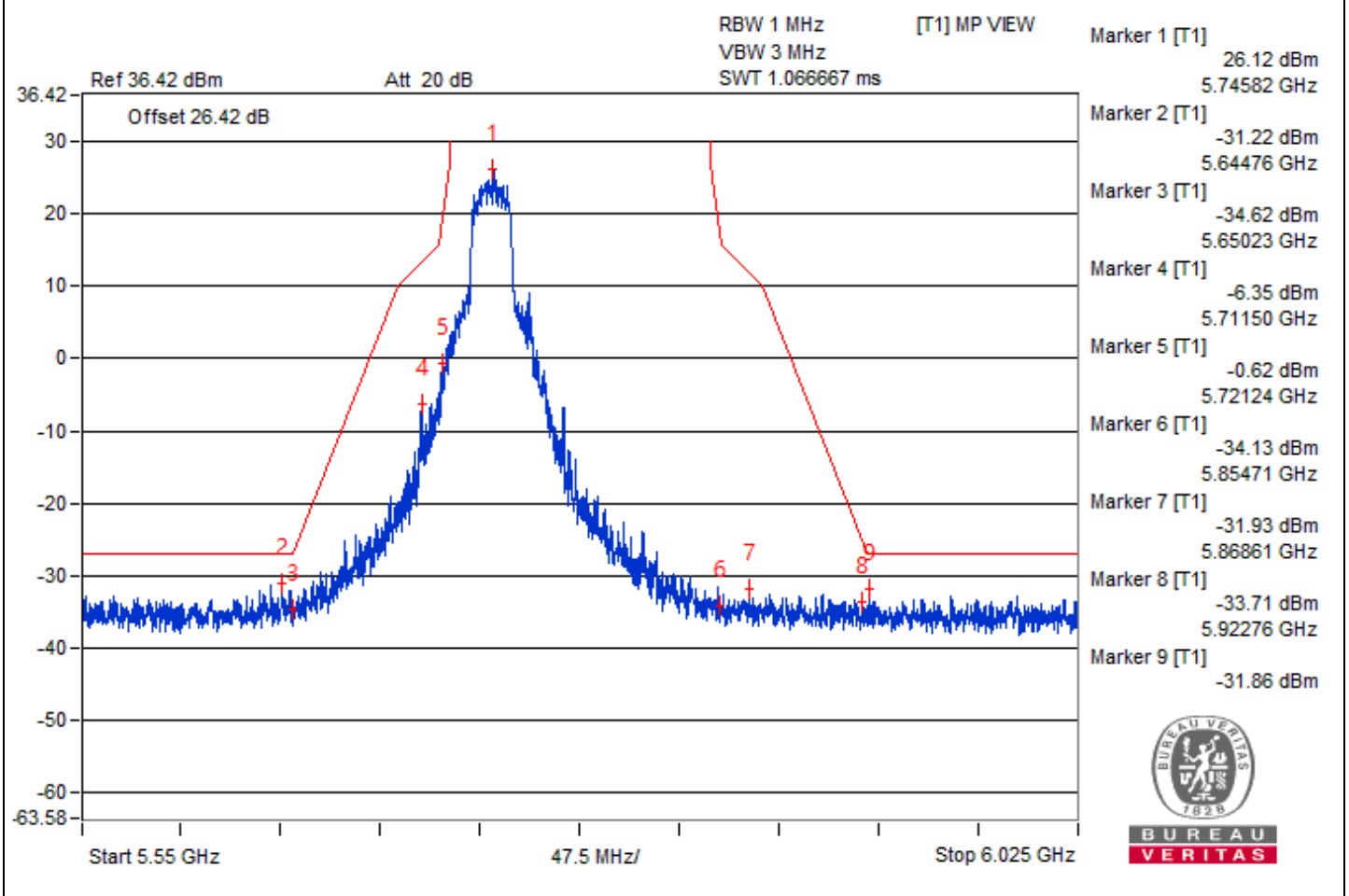

802.11be (EHT20) - Channel 157
Conducted spurious emission table

No.	Frequency (MHz)	Emission Level (dBuV/m)	Limit (dBuV/m)	Margin (dB)	Raw Value (dBm)		Correction Factor (dB)	EIRP Level (dBm)
					Chain0	Chain1		
1	3854.69	66.17 PK	74	-7.83	-36.96	-37.09	4.92	-29.09
2	3839.06	46.11 AV	54	-7.89	-56.92	-57.24	4.92	-49.15
3	7695.31	64.59 PK	74	-9.41	-39.48	-37.87	4.92	-30.67
4	7693.75	44.24 AV	54	-9.76	-58.94	-58.96	4.92	-51.02
5	11557.81	65.31 PK	74	-8.69	-40.91	-36.11	4.92	-29.95
6	11560.94	44.42 AV	54	-9.58	-58.79	-58.76	4.92	-50.84
7	#17364	54.88 PK	68.2	-13.32	-48.01	-48.64	4.92	-40.38

Remarks:

1. Margin value = Emission Level – Limit value
2. The other emission levels were very low against the limit.
3. " # " : The frequency is out of the restricted band.



Chain 0

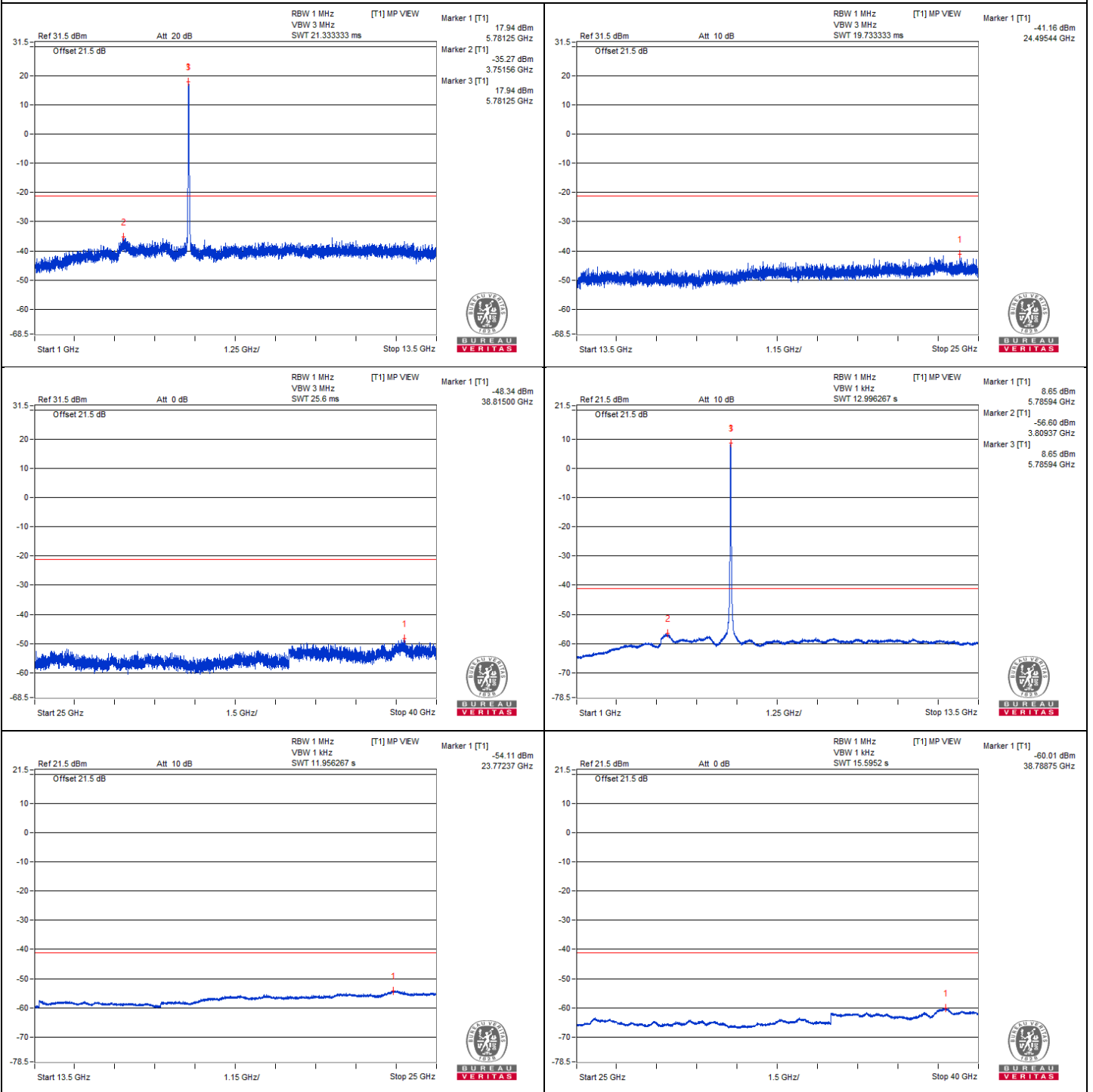



Chain 1

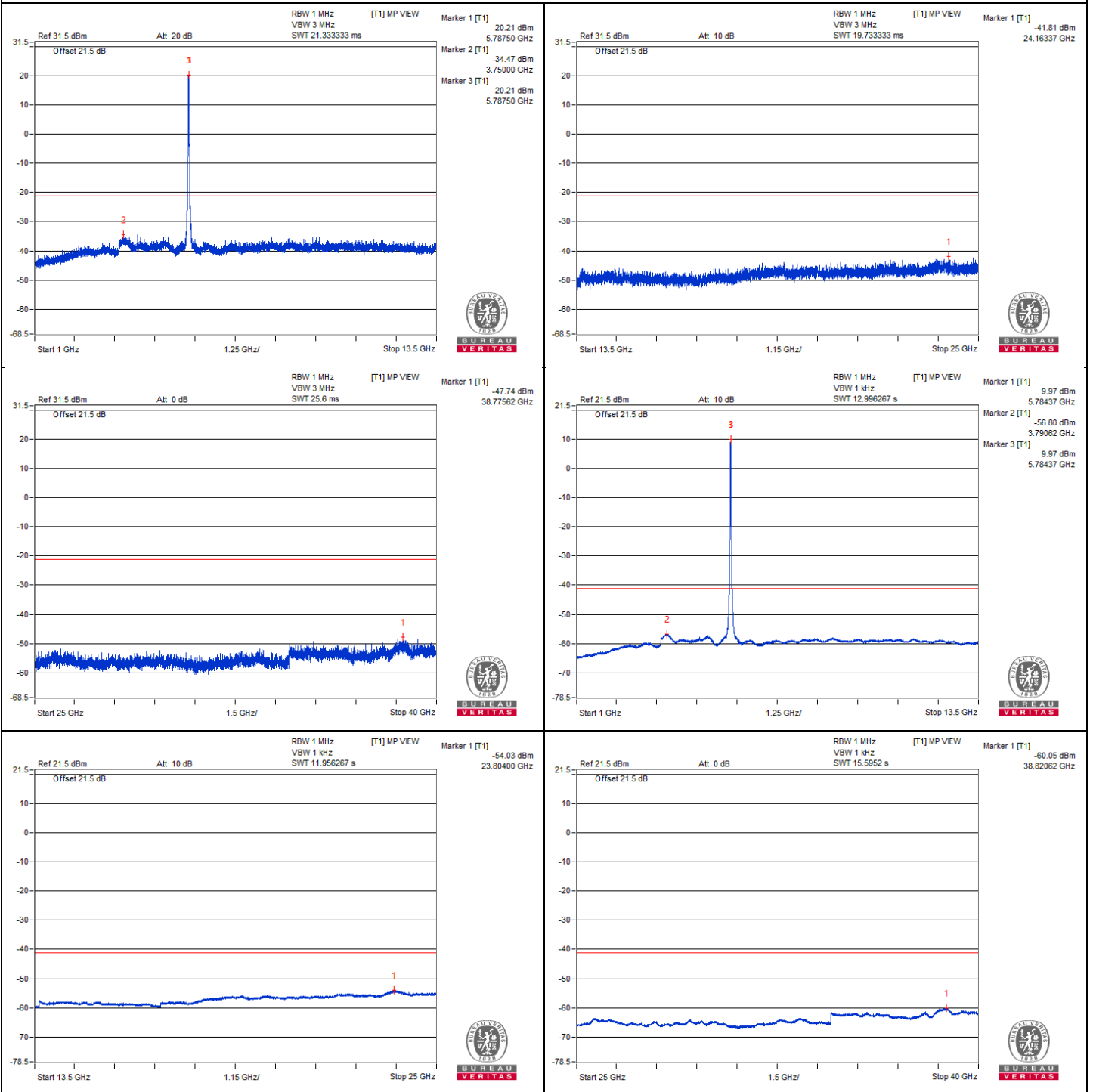



Bandedge table

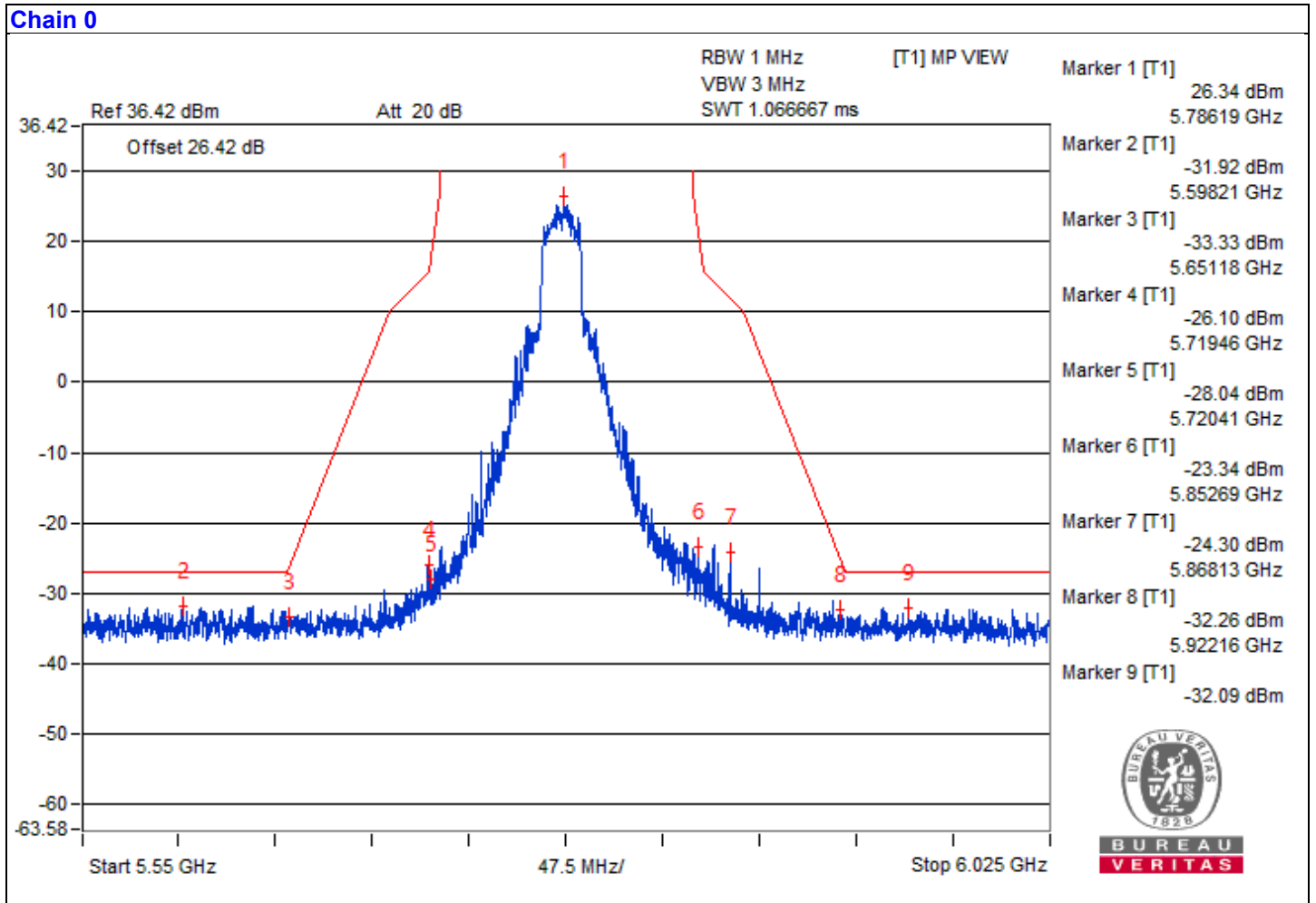



Chain 1

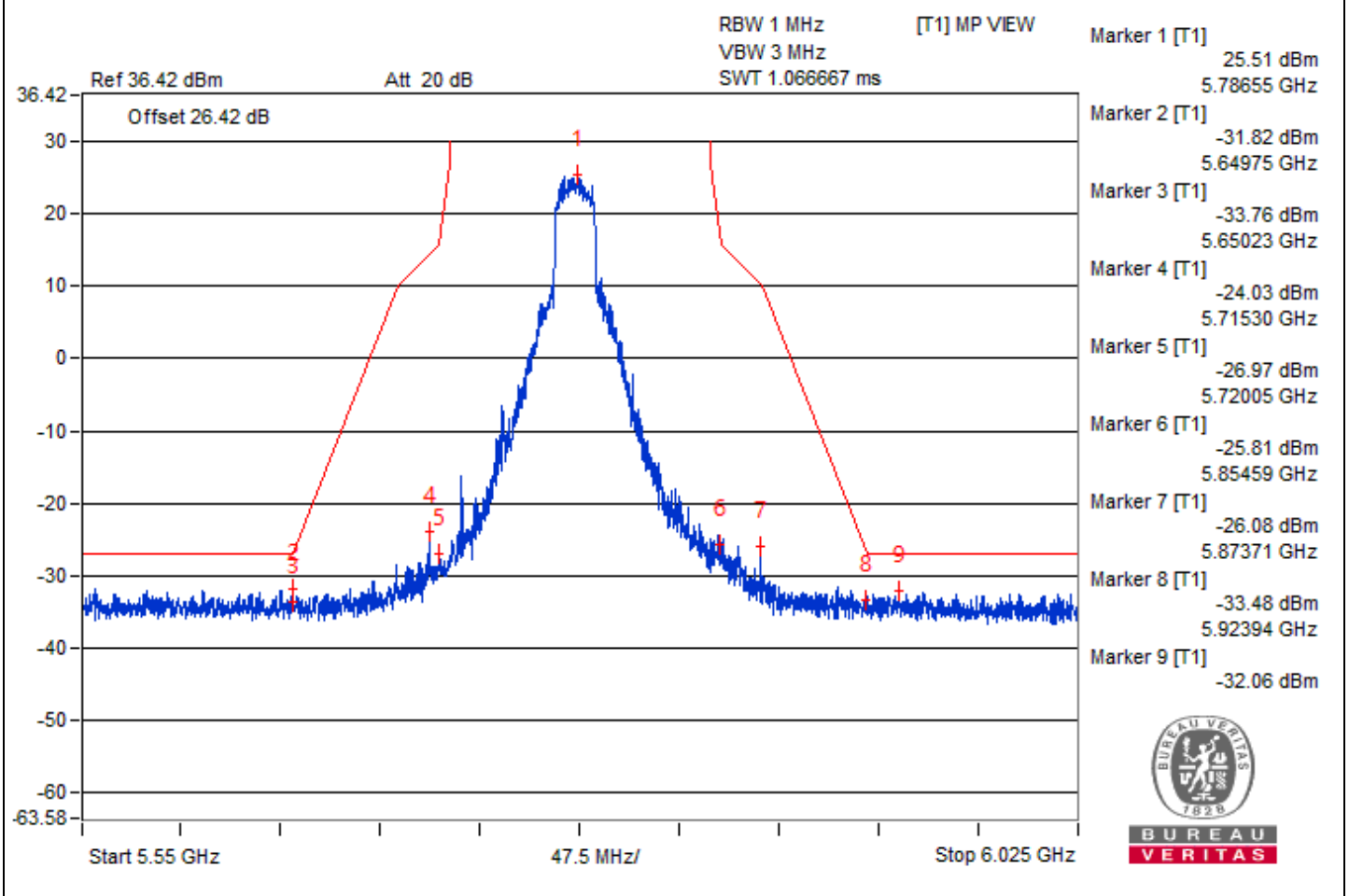

802.11be (EHT20) - Channel 165

Conducted spurious emission table

No.	Frequency (MHz)	Emission Level (dBuV/m)	Limit (dBuV/m)	Margin (dB)	Raw Value (dBm)		Correction Factor (dB)	EIRP Level (dBm)
					Chain0	Chain1		
1	3878.12	66.79 PK	74	-7.21	-38.6	-34.95	4.92	-28.47
2	3867.19	45.95 AV	54	-8.05	-57.31	-57.18	4.92	-49.31
3	7748.44	65.27 PK	74	-8.73	-38.83	-37.17	4.92	-29.99
4	11642.19	64.91 PK	74	-9.09	-38.93	-37.71	4.92	-30.35
5	11631.25	44.03 AV	54	-9.97	-59.33	-59	4.92	-51.23
6	#17474.69	55.82 PK	68.2	-12.38	-47.15	-47.61	4.92	-39.44

Remarks:

1. Margin value = Emission Level – Limit value
2. The other emission levels were very low against the limit.
3. " # " : The frequency is out of the restricted band.



Chain 0

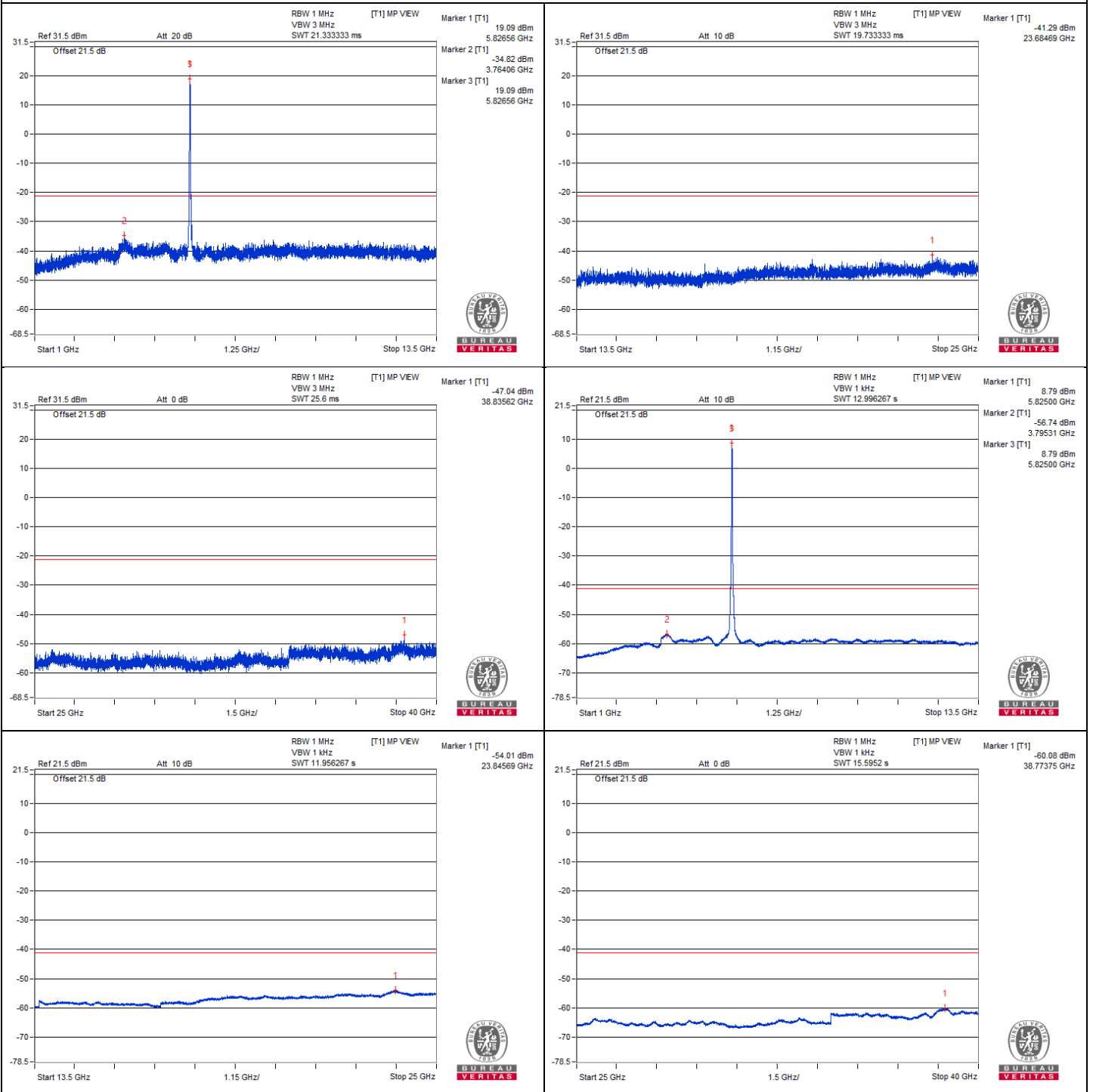



Chain 1

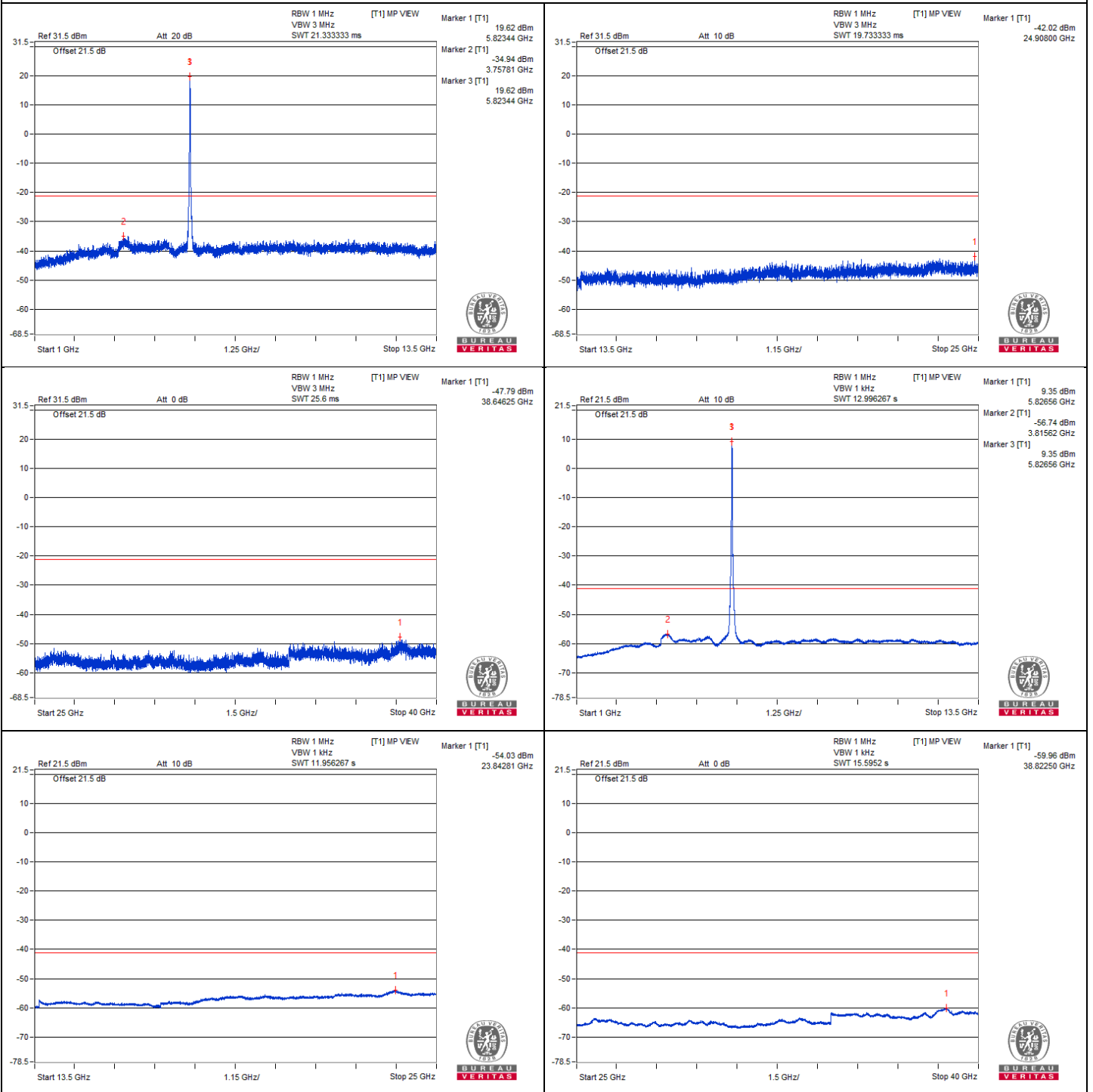



Bandedge table

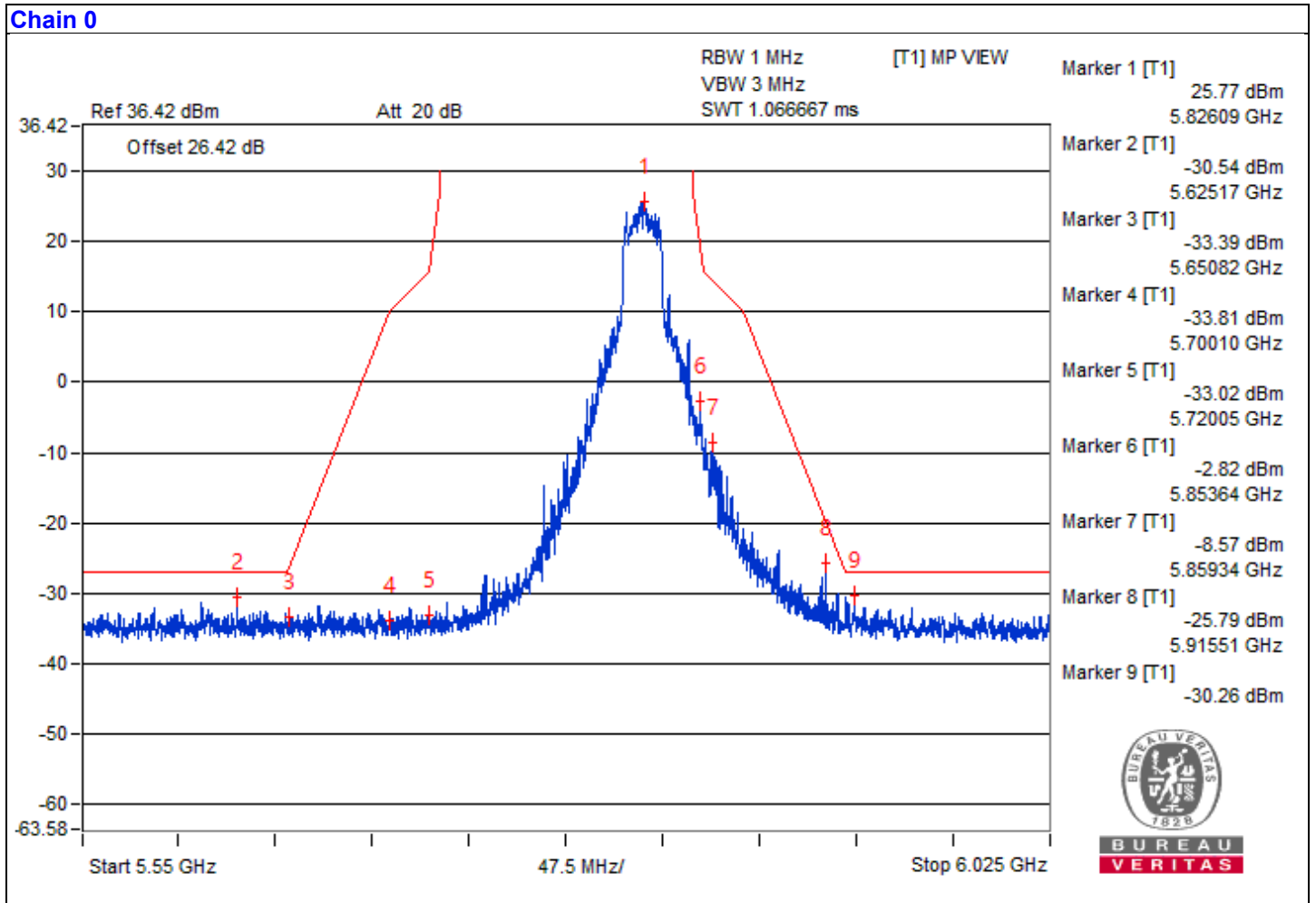



Chain 1

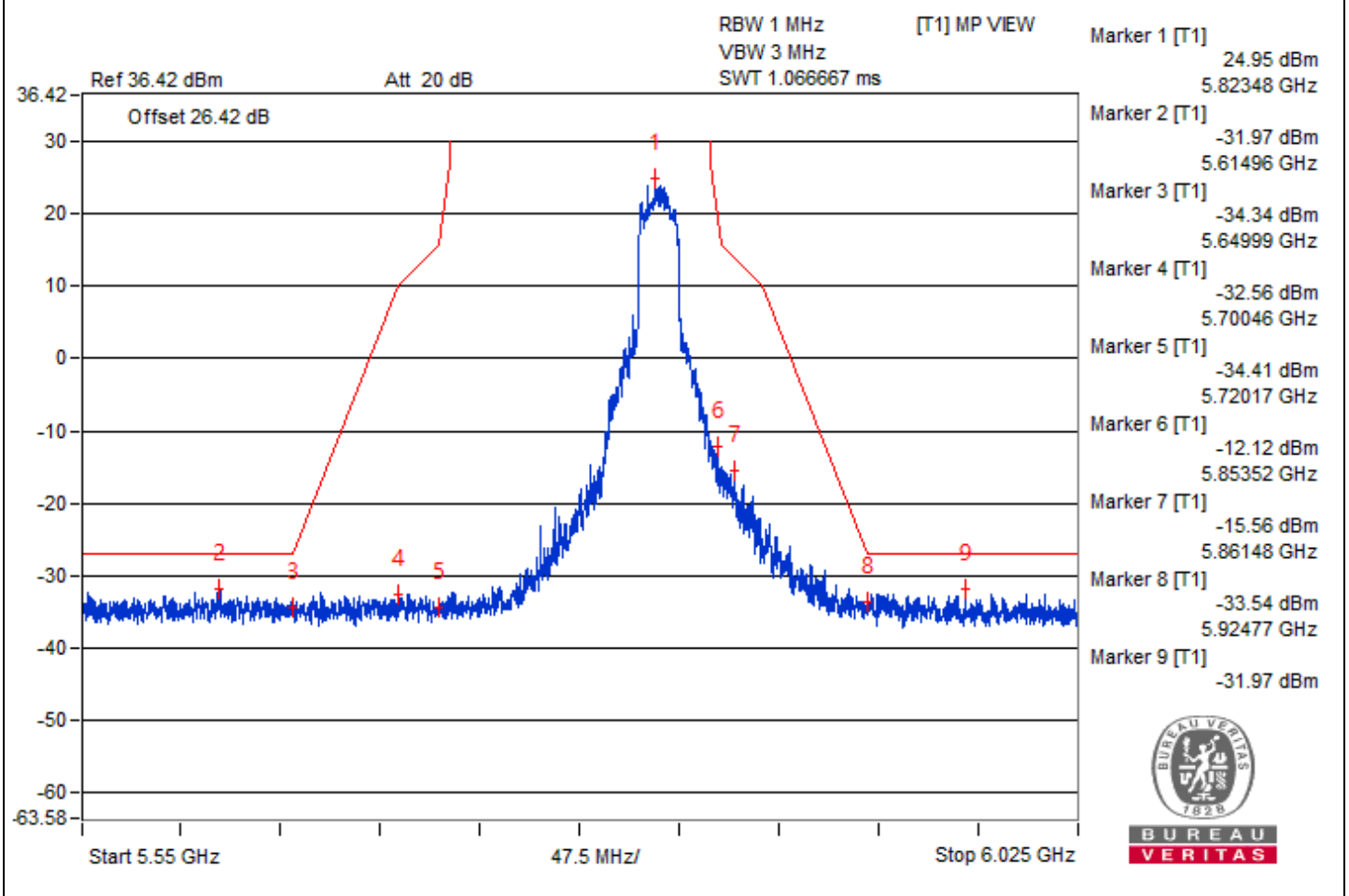

802.11be (EHT40) - Channel 38

Conducted spurious emission table

No.	Frequency (MHz)	Emission Level (dBuV/m)	Limit (dBuV/m)	Margin (dB)	Raw Value (dBm)		Correction Factor (dB)	EIRP Level (dBm)
					Chain0	Chain1		
1	#3462.5	62.96 PK	68.2	-5.24	-41.34	-39.35	4.92	-32.30
2	#6903.12	63.61 PK	68.2	-4.59	-38.44	-41.12	4.92	-31.65
3	#10370.31	64.04 PK	68.2	-4.16	-38.88	-39.44	4.92	-31.22
4	15585.81	54.54 PK	74	-19.46	-48.99	-48.33	4.92	-40.72
5	15587.25	44.6 AV	54	-9.4	-58.62	-58.57	4.92	-50.66

Remarks:

1. Margin value = Emission Level – Limit value
2. The other emission levels were very low against the limit.
3. " # " : The frequency is out of the restricted band.



Chain 0

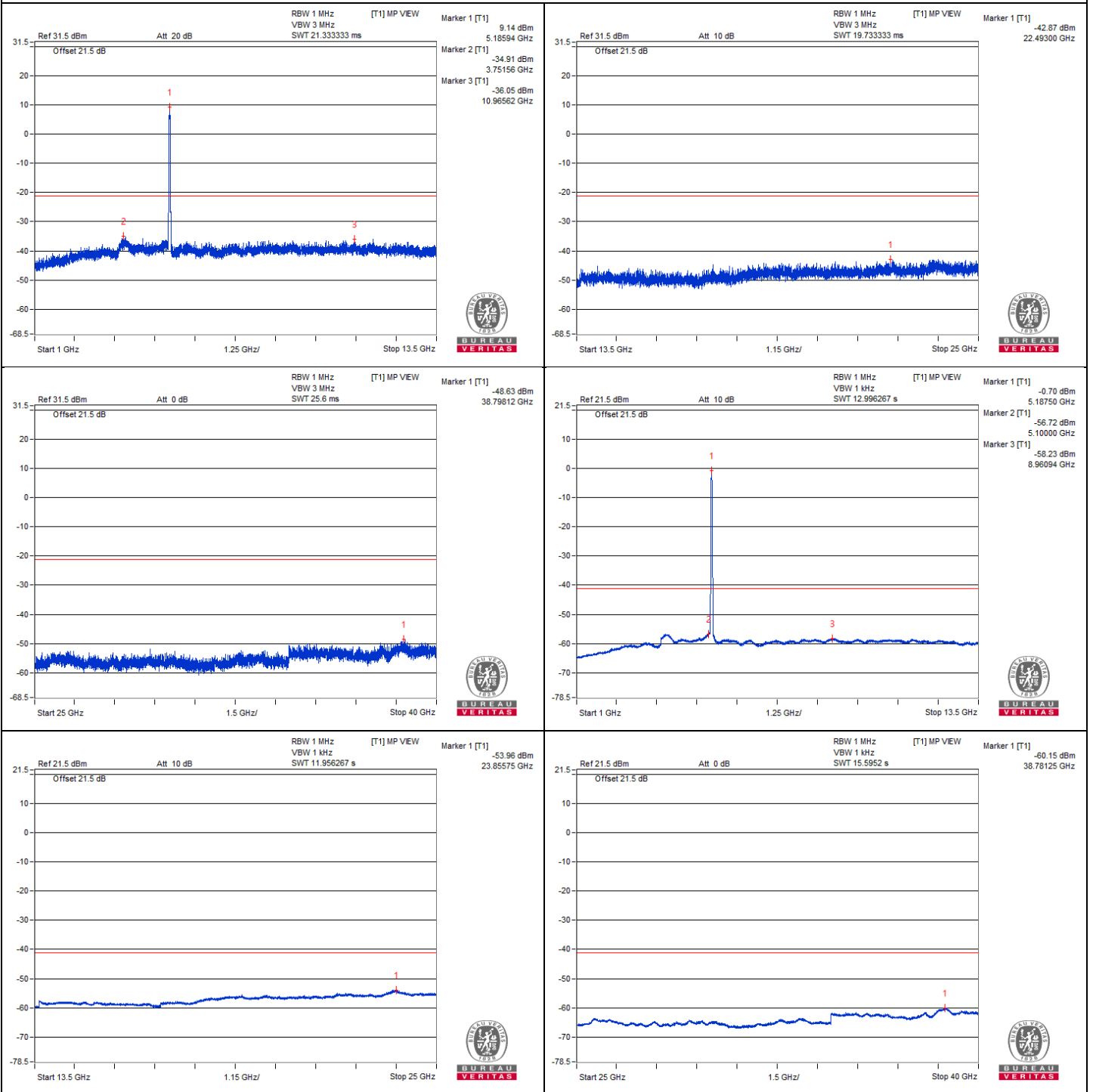



Chain 1

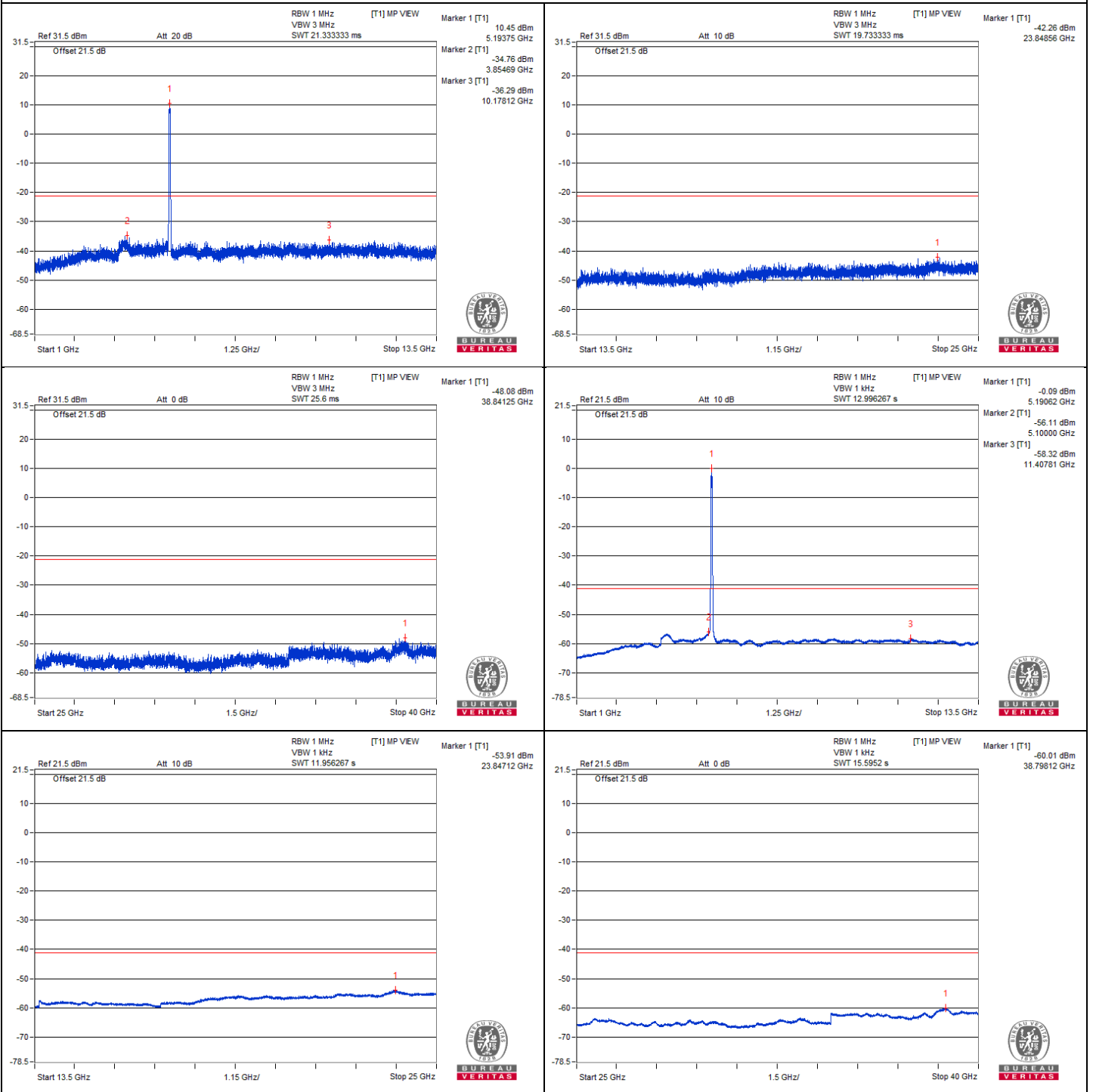

Bandedge table

No.	Frequency (MHz)	Emission Level (dBuV/m)	Limit (dBuV/m)	Margin (dB)	Raw Value (dBm)		Correction Factor (dB)	EIRP Level (dBm)
					Chain0	Chain1		
1	5148.87	61.24 PK	74	-12.76	-41.28	-42.74	4.92	-34.02
2	5149.77	50.79 AV	54	-3.21	-52.36	-52.44	4.92	-44.47

Remarks:

1. Margin value = Emission Level – Limit value
2. The other emission levels were very low against the limit.

Chain 0

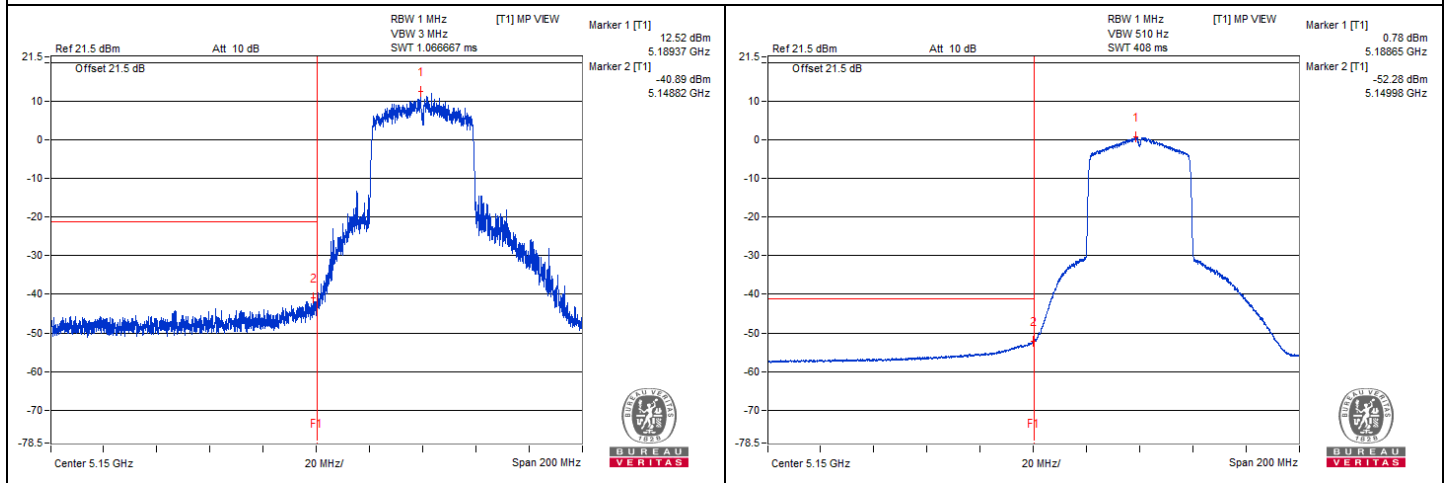

Chain 1

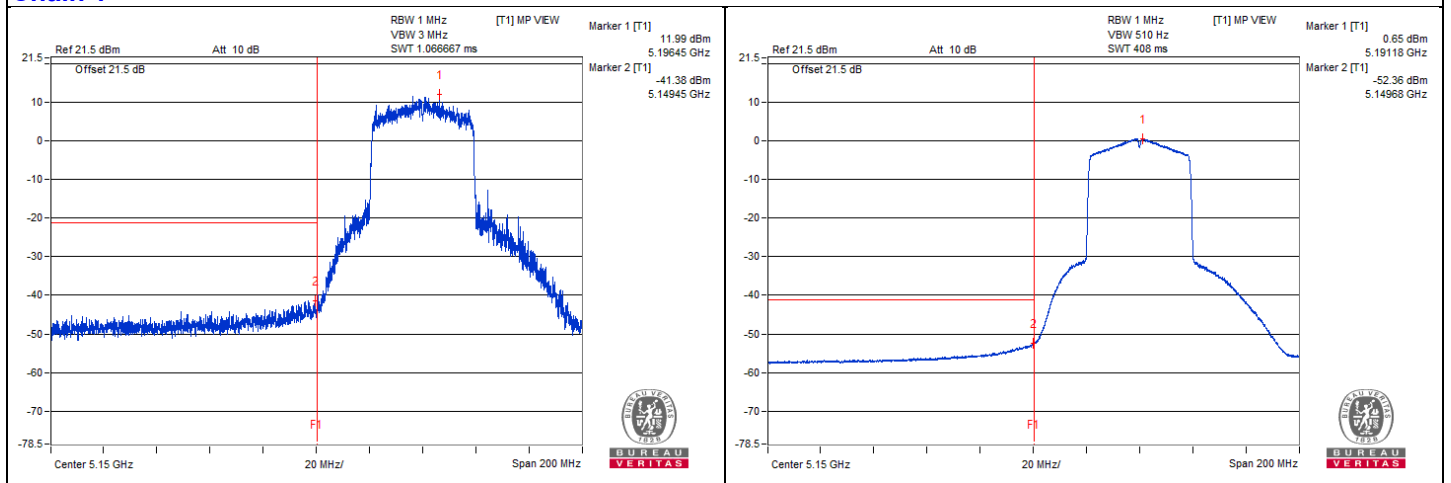

802.11be (EHT40) - Channel 46

Conducted spurious emission table

No.	Frequency (MHz)	Emission Level (dBuV/m)	Limit (dBuV/m)	Margin (dB)	Raw Value (dBm)		Correction Factor (dB)	EIRP Level (dBm)
					Chain0	Chain1		
1	#3487.5	63.36 PK	68.2	-4.84	-38.78	-41.23	4.92	-31.90
2	#6959.37	64.55 PK	68.2	-3.65	-39.11	-38.21	4.92	-30.71
3	#10479.69	65.42 PK	68.2	-2.78	-37.77	-37.78	4.92	-29.84
4	15679.25	54.63 PK	74	-19.37	-49.18	-48.01	4.92	-40.63
5	15672.06	44.64 AV	54	-9.36	-58.5	-58.6	4.92	-50.62

Remarks:

1. Margin value = Emission Level – Limit value
2. The other emission levels were very low against the limit.
3. " # " : The frequency is out of the restricted band.



Chain 0

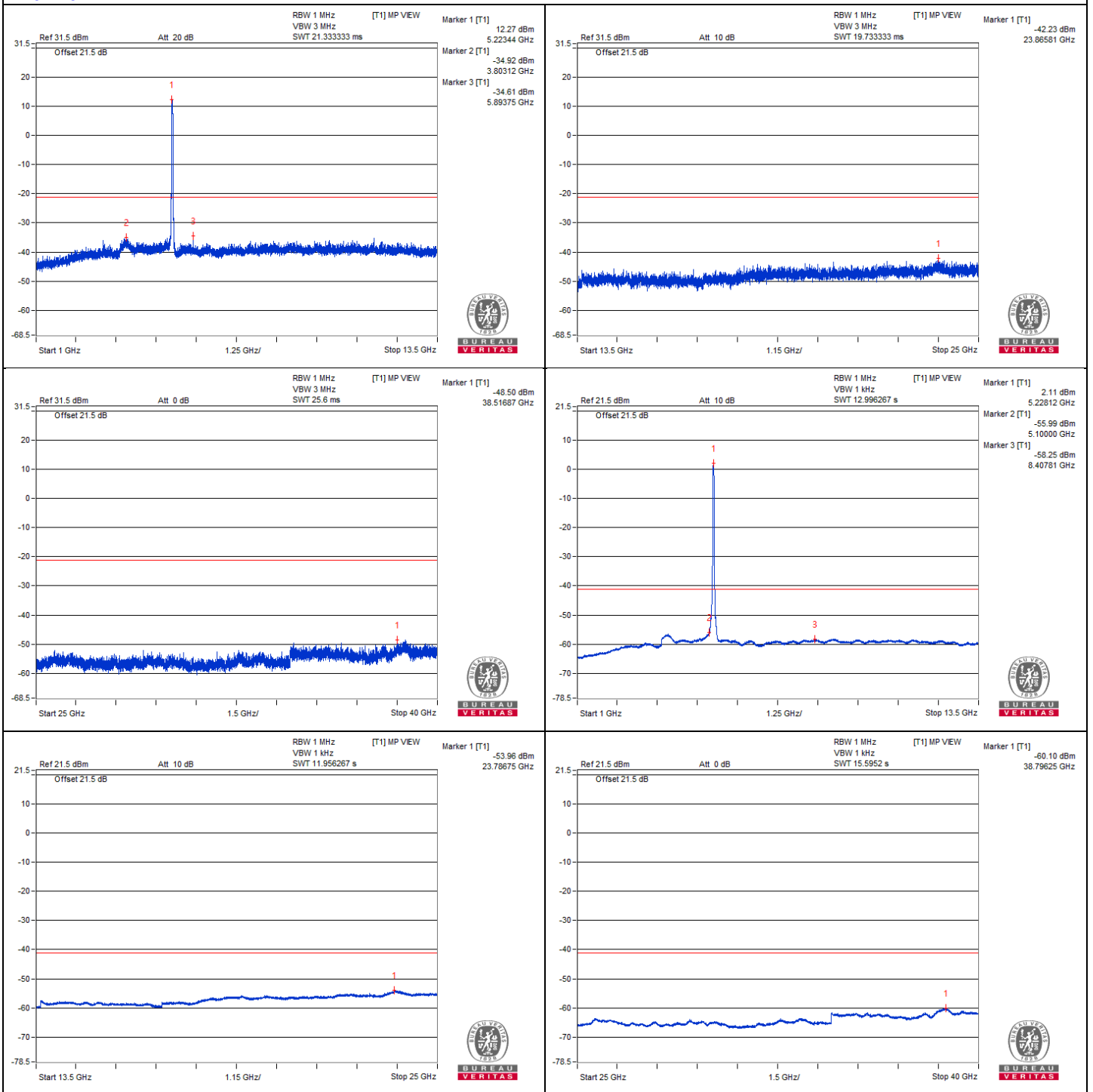



Chain 1

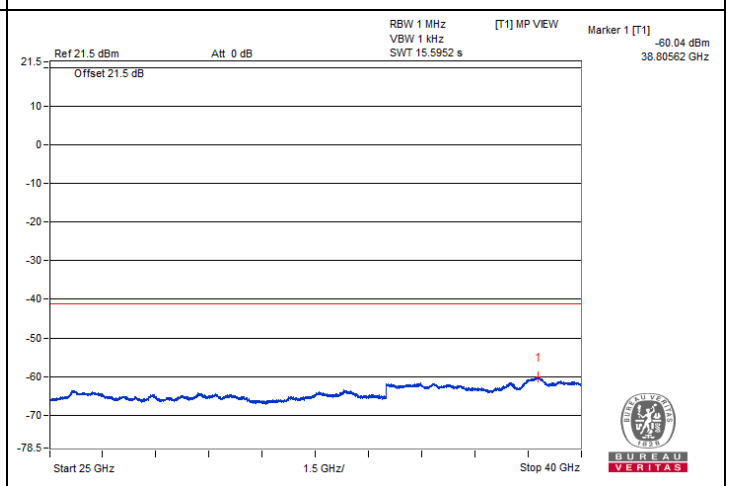
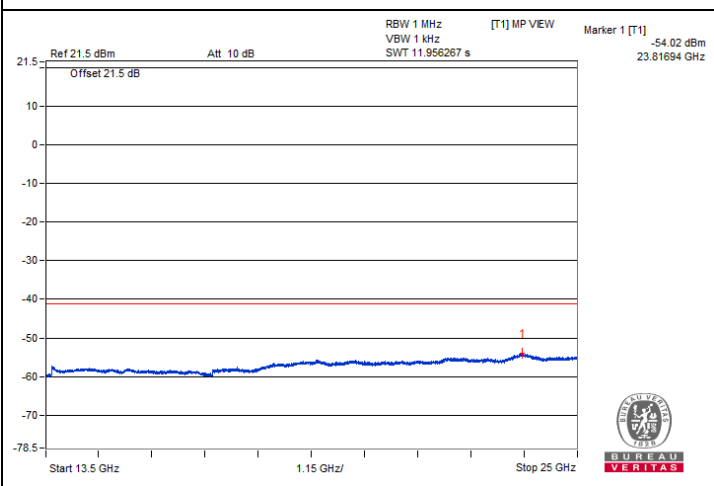
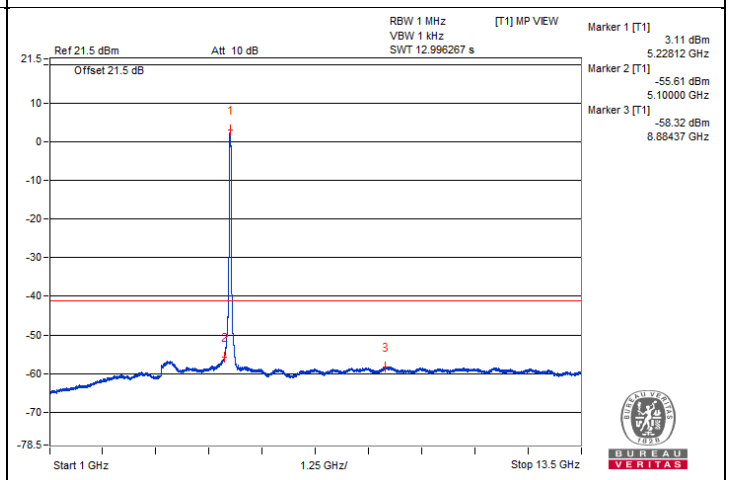
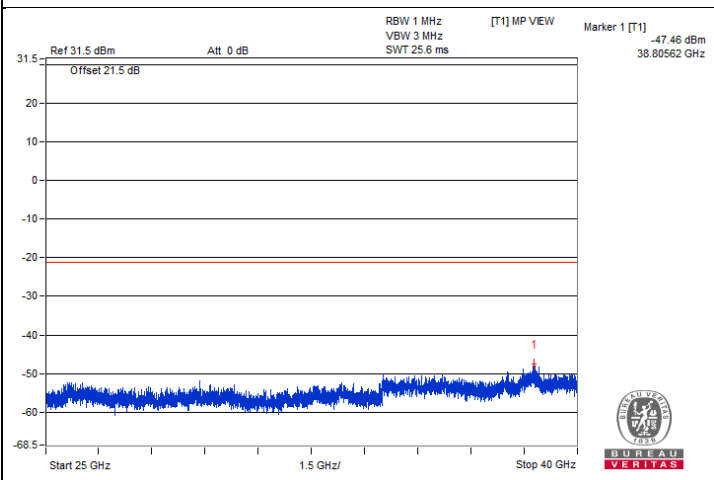
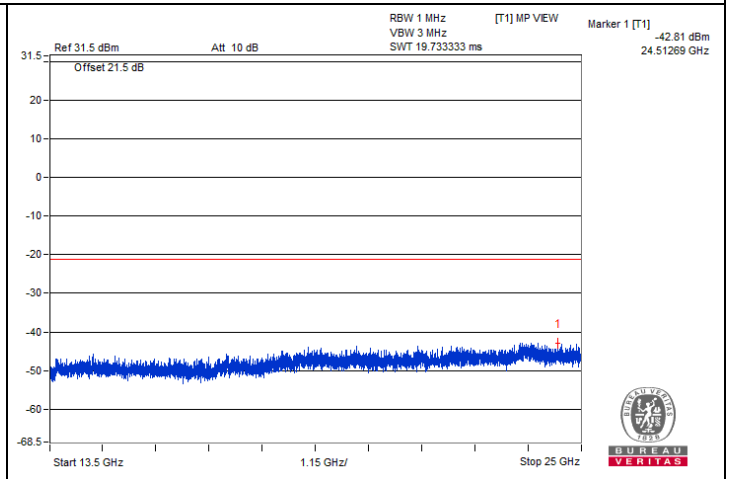
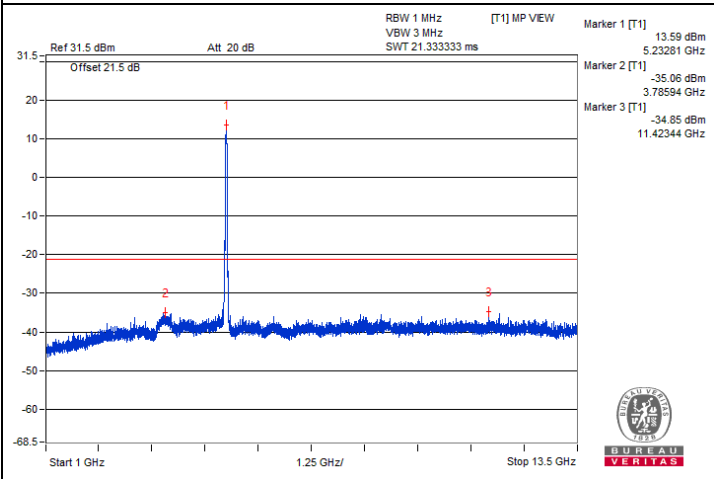

Bandedge table

No.	Frequency (MHz)	Emission Level (dBuV/m)	Limit (dBuV/m)	Margin (dB)	Raw Value (dBm)		Correction Factor (dB)	EIRP Level (dBm)
					Chain0	Chain1		
1	5137.57	64.46 PK	74	-9.54	-37.28	-40.92	4.92	-30.80
2	5149.98	51.68 AV	54	-2.32	-51.6	-51.43	4.92	-43.58

Remarks:

1. Margin value = Emission Level – Limit value
2. The other emission levels were very low against the limit.

Chain 0

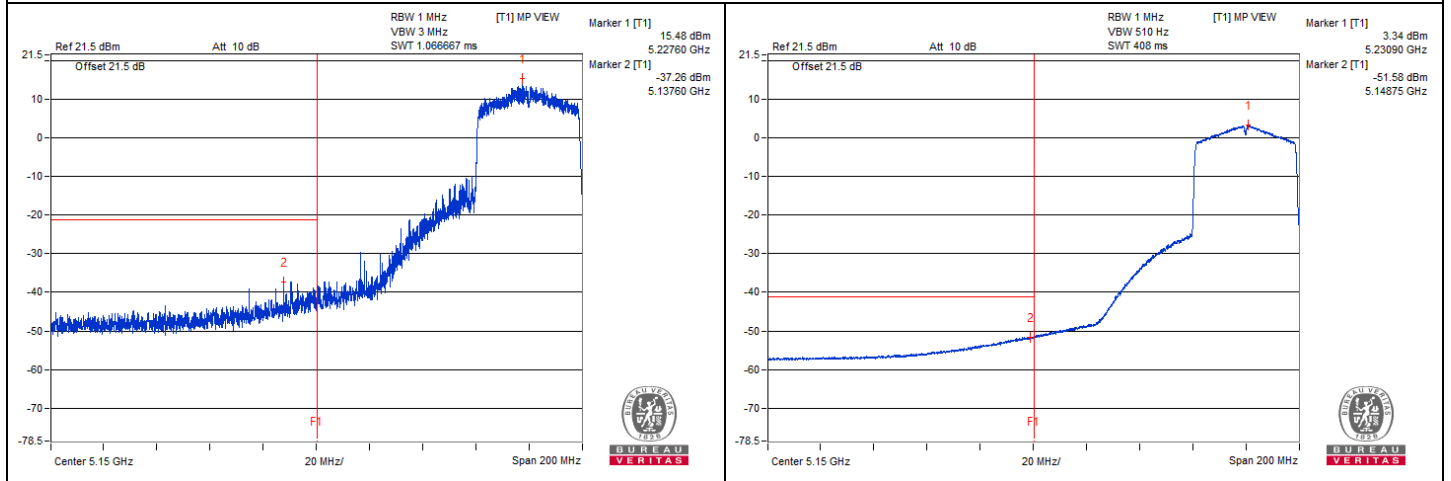

Chain 1

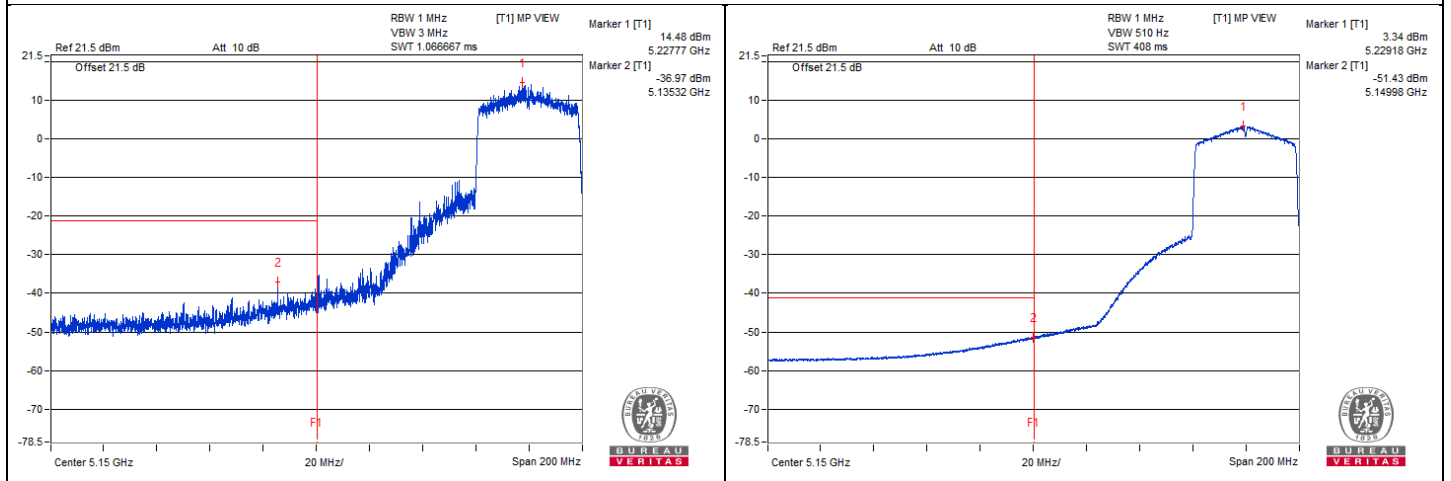

802.11be (EHT40) - Channel 54
Conducted spurious emission table

No.	Frequency (MHz)	Emission Level (dBuV/m)	Limit (dBuV/m)	Margin (dB)	Raw Value (dBm)		Correction Factor (dB)	EIRP Level (dBm)
					Chain0	Chain1		
1	3512.5	62.89 PK	74	-11.11	-42.06	-39.05	4.92	-32.37
2	3521.87	42.24 AV	54	-11.76	-60.7	-61.22	4.92	-53.02
3	#7028.12	63.67 PK	68.2	-4.53	-38.87	-40.29	4.92	-31.59
4	#10526.56	64.53 PK	68.2	-3.67	-40.1	-37.58	4.92	-30.73
5	15818.69	54.7 PK	74	-19.3	-48.89	-48.13	4.92	-40.56
6	15812.94	44.45 AV	54	-9.55	-58.8	-58.68	4.92	-50.81

Remarks:

1. Margin value = Emission Level – Limit value
2. The other emission levels were very low against the limit.
3. " # " : The frequency is out of the restricted band.



Chain 0

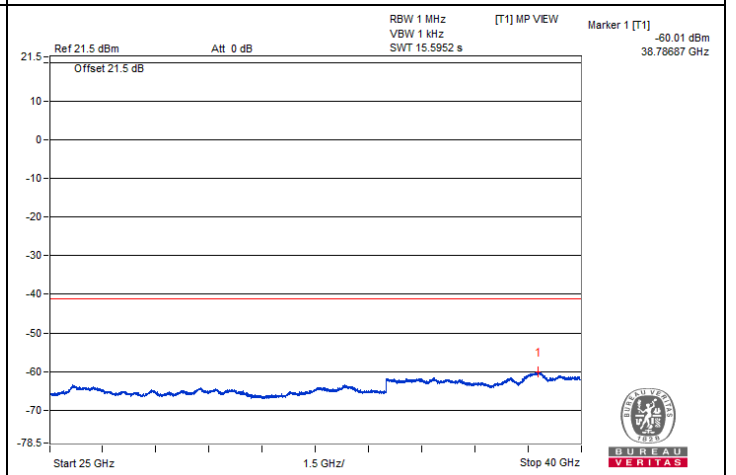
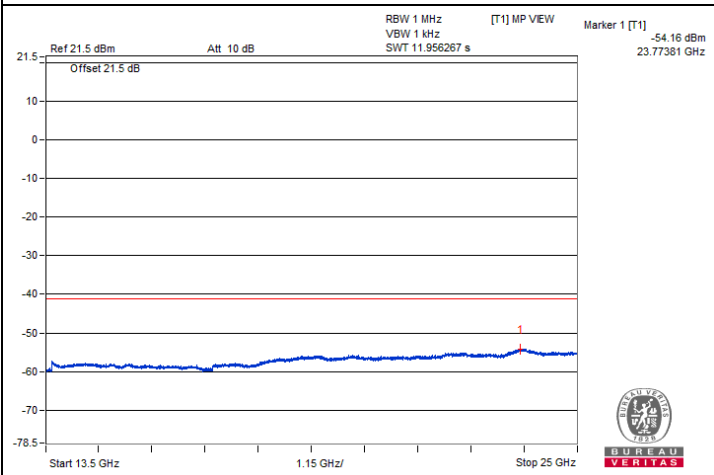
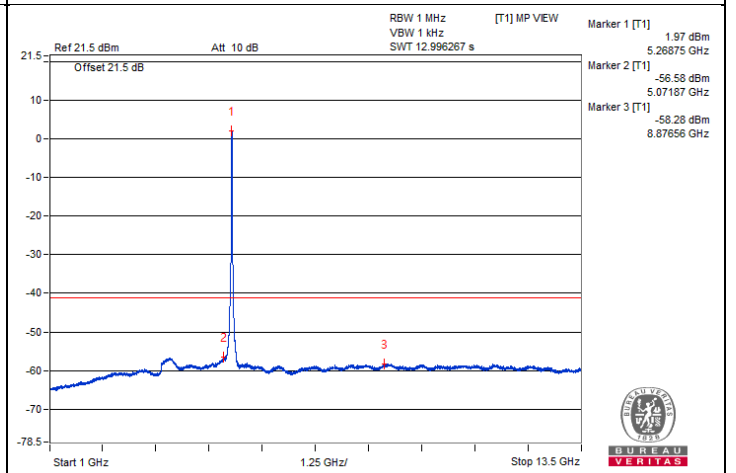
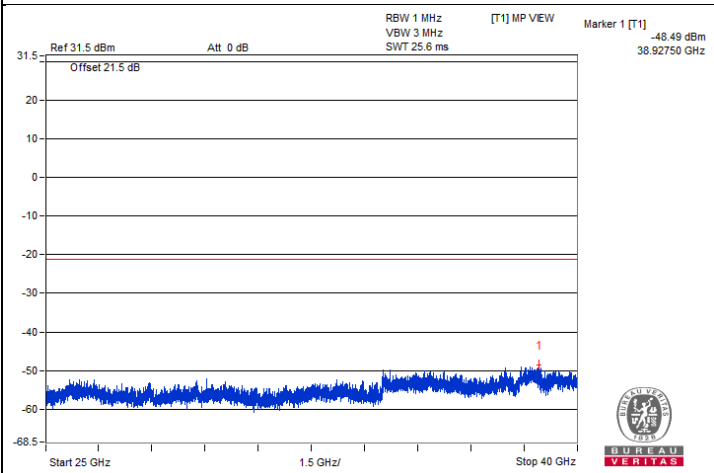
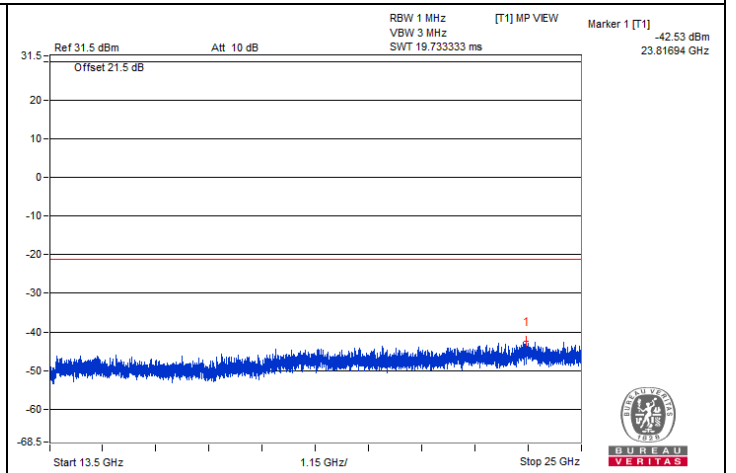
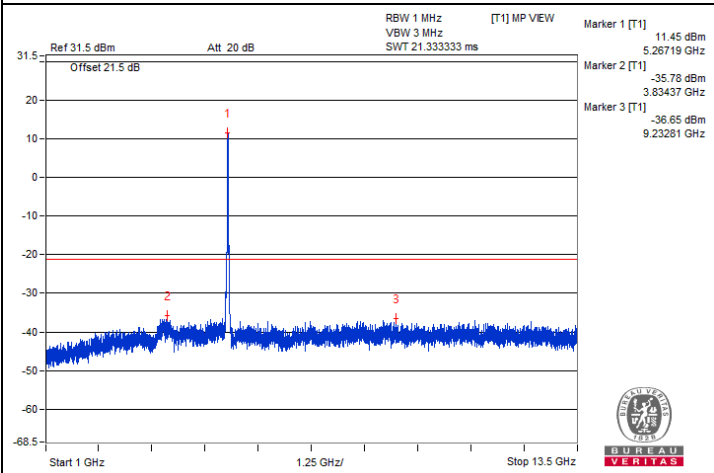



Chain 1

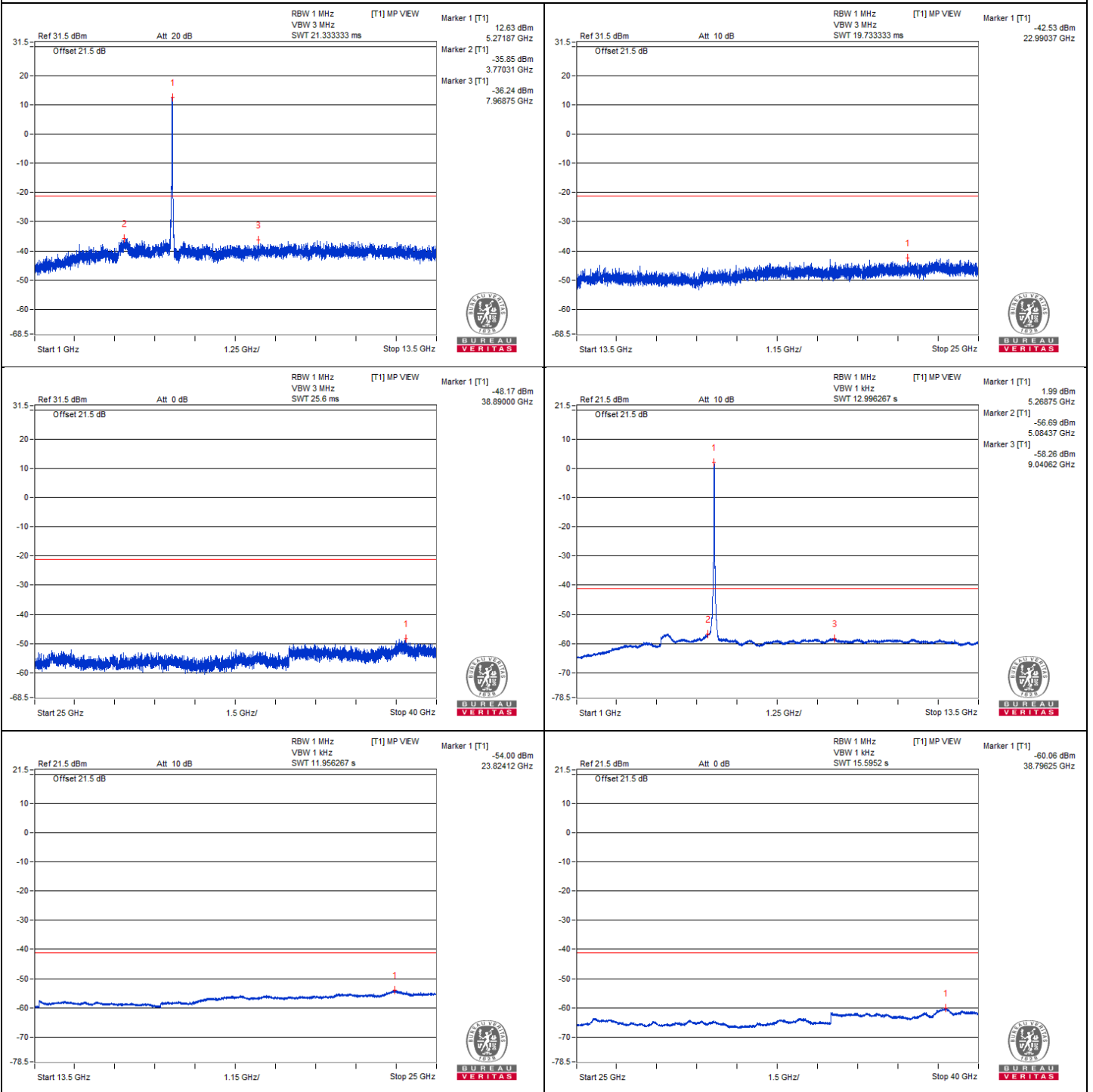

Bandedge table

No.	Frequency (MHz)	Emission Level (dBuV/m)	Limit (dBuV/m)	Margin (dB)	Raw Value (dBm)		Correction Factor (dB)	EIRP Level (dBm)
					Chain0	Chain1		
1	5354.7	65.58 PK	74	-8.42	-42.93	-35.29	4.92	-29.68
2	5350.05	52.53 AV	54	-1.47	-50.36	-50.98	4.92	-42.73

Remarks:

1. Margin value = Emission Level – Limit value
2. The other emission levels were very low against the limit.

Chain 0

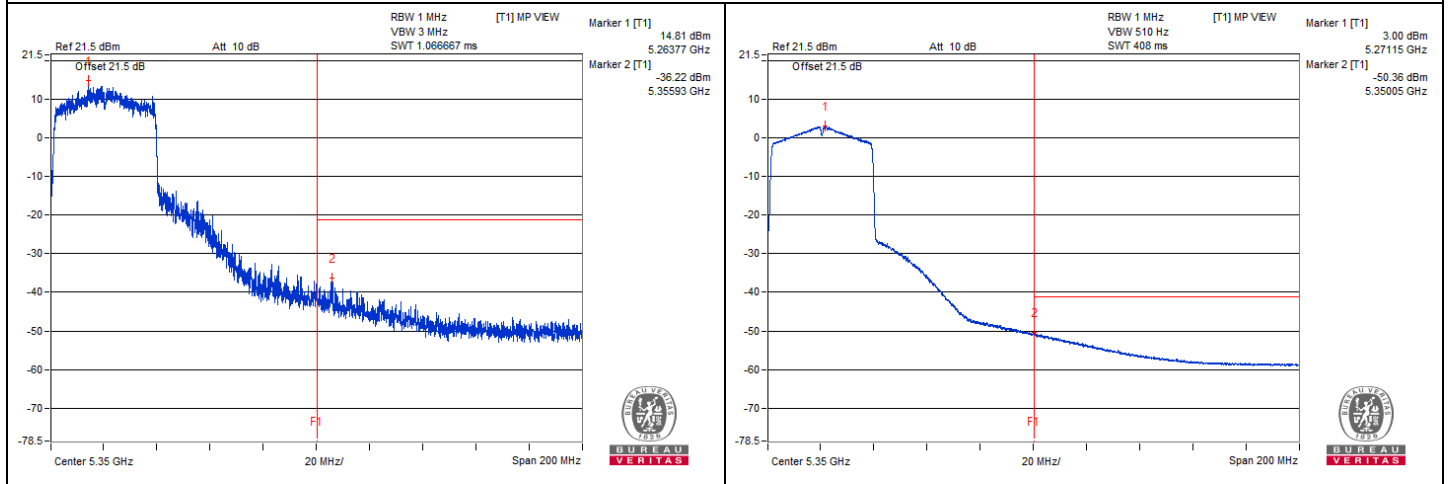

Chain 1

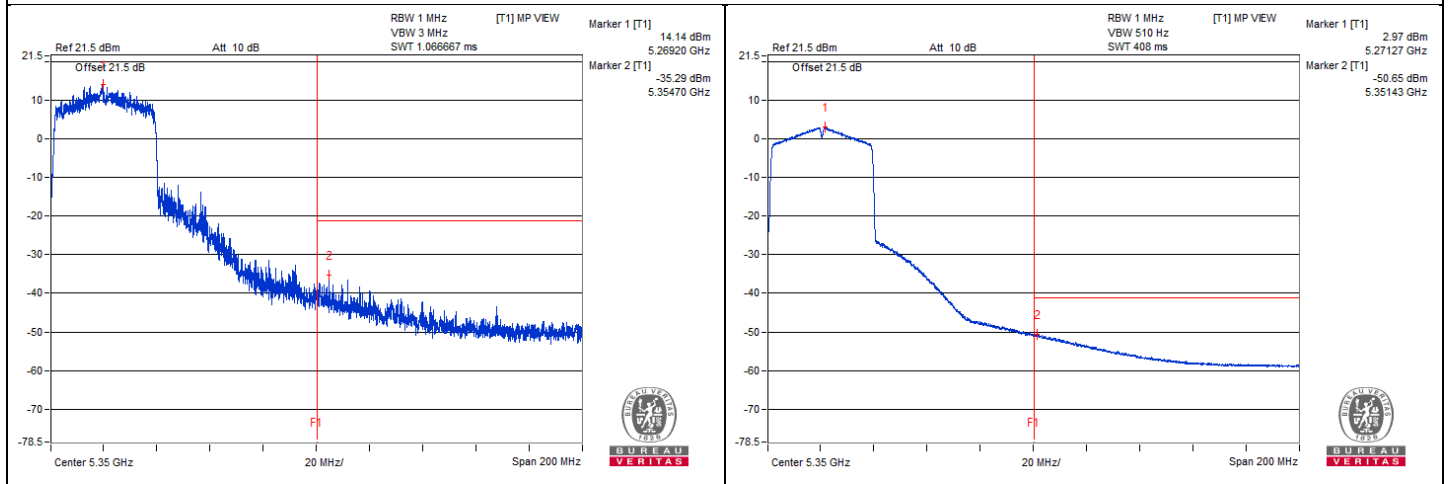

802.11be (EHT40) - Channel 62
Conducted spurious emission table

No.	Frequency (MHz)	Emission Level (dBuV/m)	Limit (dBuV/m)	Margin (dB)	Raw Value (dBm)		Correction Factor (dB)	EIRP Level (dBm)
					Chain0	Chain1		
1	3548.44	63.63 PK	74	-10.37	-40.32	-38.92	4.92	-31.63
2	3550	42.53 AV	54	-11.47	-60.56	-60.76	4.92	-52.73
3	#7100	64.54 PK	68.2	-3.66	-37.94	-39.51	4.92	-30.72
4	10623.44	65.64 PK	74	-8.36	-38.57	-36.72	4.92	-29.62
5	10632.81	44.31 AV	54	-9.69	-58.88	-58.89	4.92	-50.95
6	15915	54.68 PK	74	-19.32	-47.06	-50.69	4.92	-40.58
7	15916.44	44.44 AV	54	-9.56	-58.74	-58.77	4.92	-50.82

Remarks:

1. Margin value = Emission Level – Limit value
2. The other emission levels were very low against the limit.
3. " # " : The frequency is out of the restricted band.



Chain 0

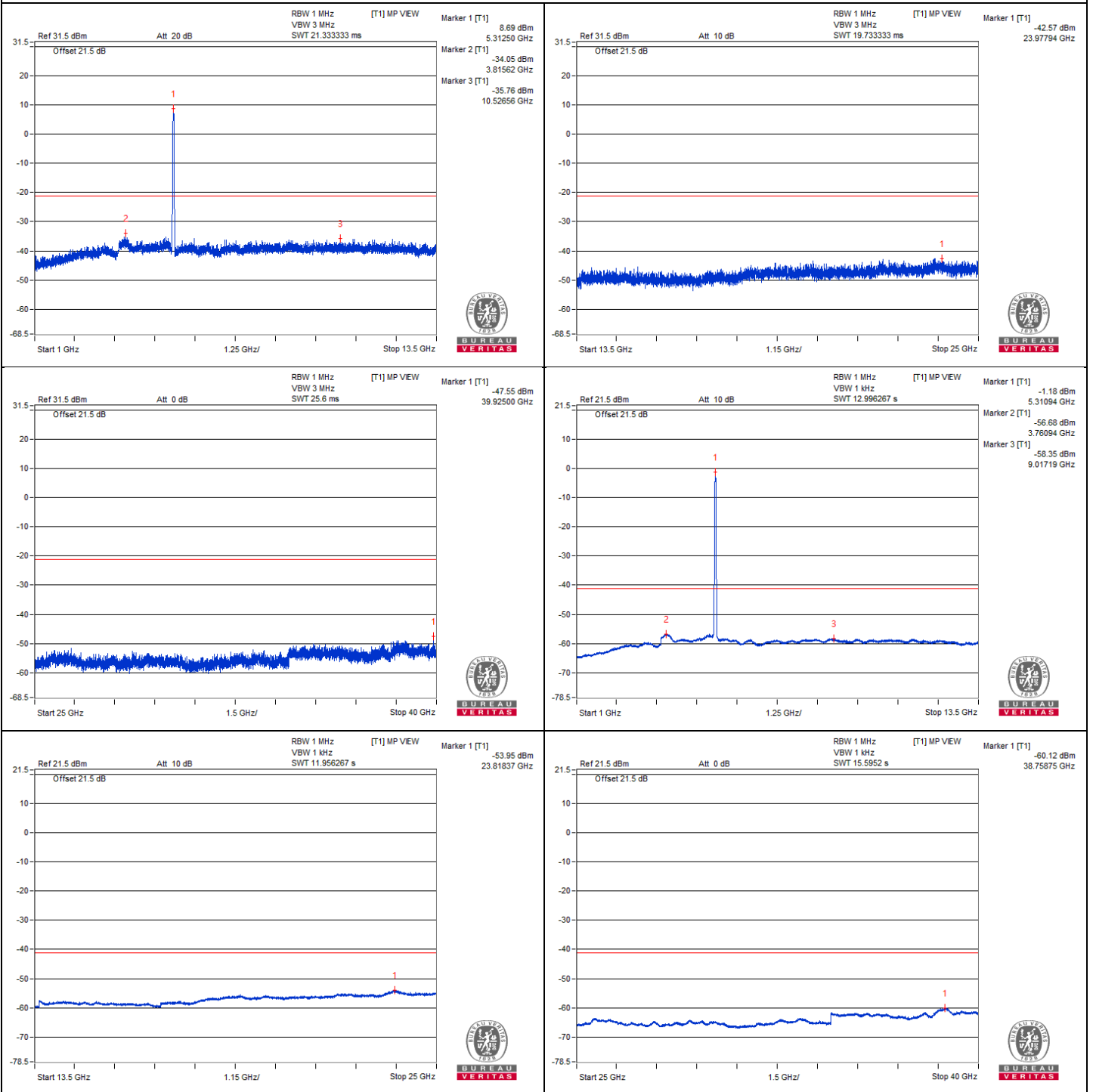



Chain 1

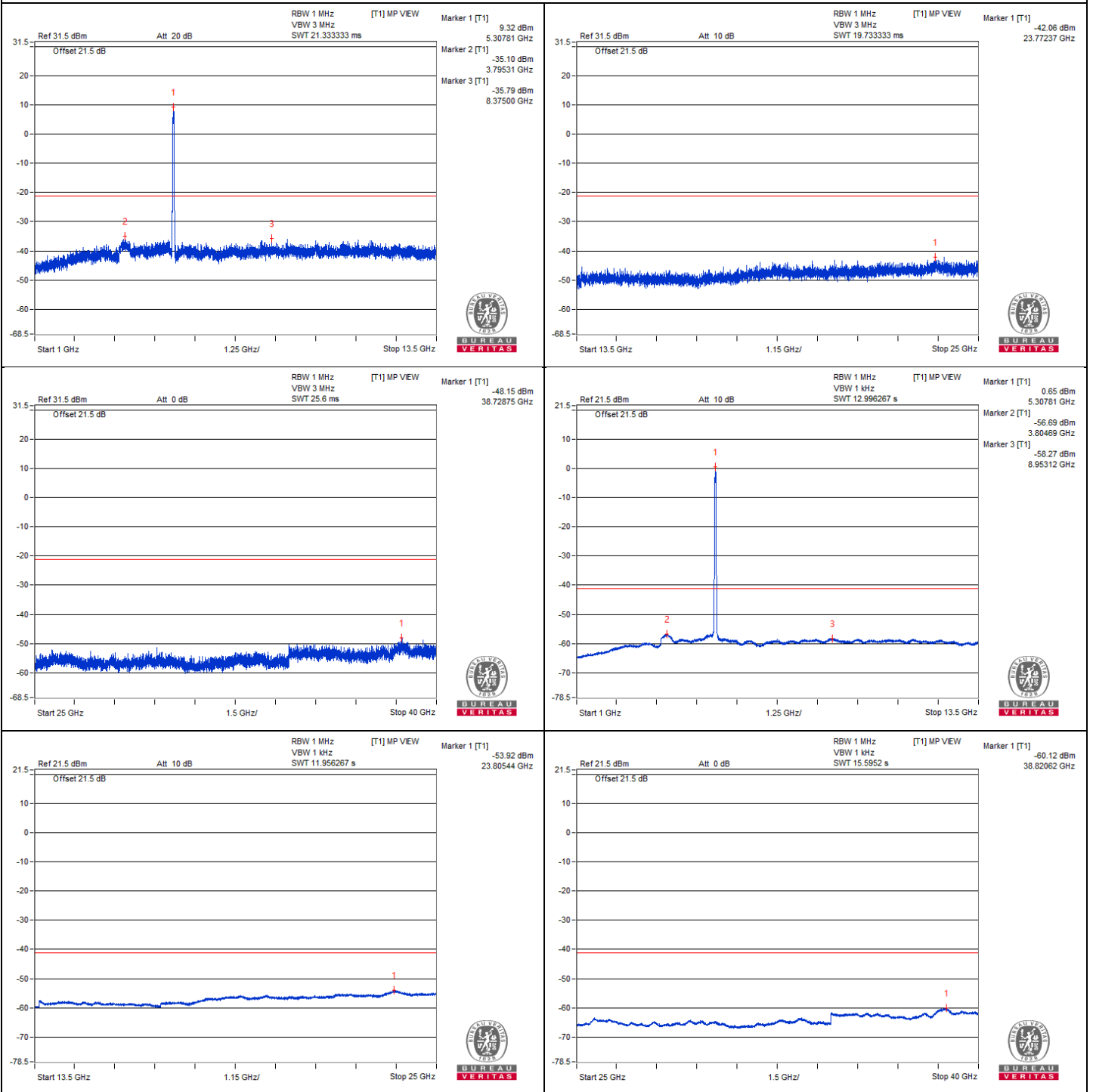

Bandedge table

No.	Frequency (MHz)	Emission Level (dBuV/m)	Limit (dBuV/m)	Margin (dB)	Raw Value (dBm)		Correction Factor (dB)	EIRP Level (dBm)
					Chain0	Chain1		
1	5351	61.51 PK	74	-12.49	-41.15	-42.28	4.92	-33.75
2	5350.73	49.99 AV	54	-4.01	-53.5	-52.92	4.92	-45.27

Remarks:

1. Margin value = Emission Level – Limit value
2. The other emission levels were very low against the limit.

Chain 0

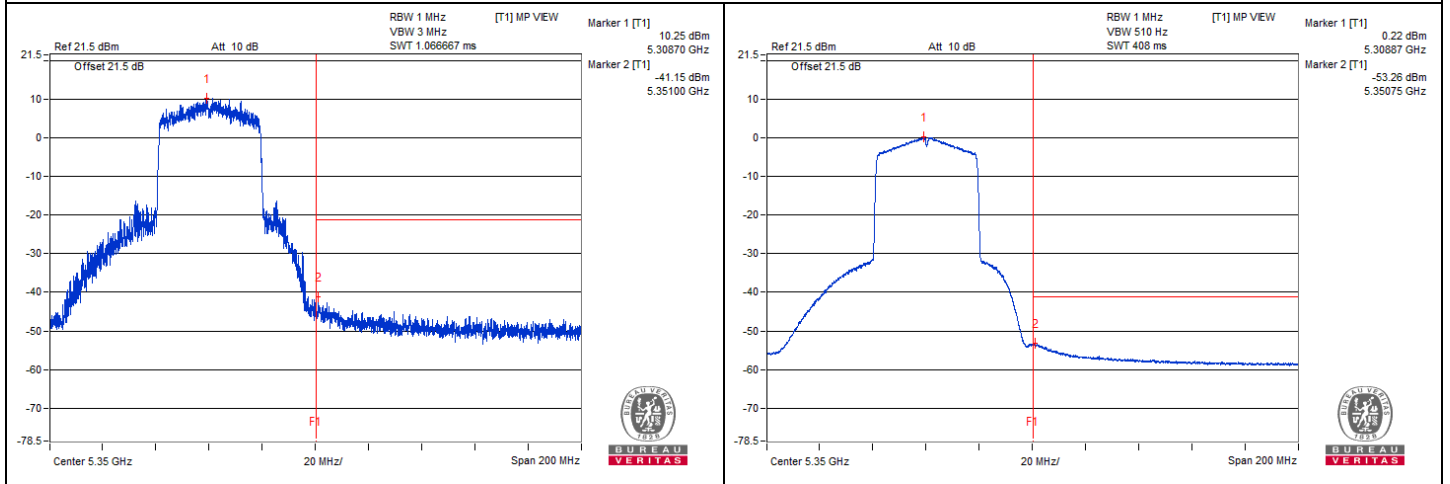

Chain 1

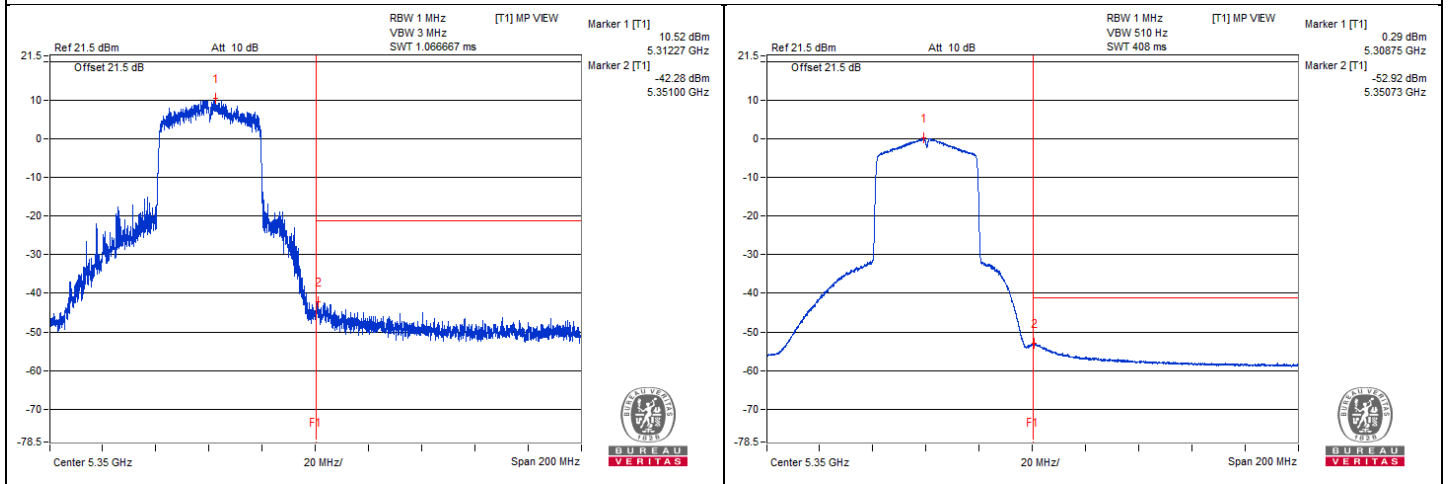

802.11be (EHT80) - Channel 106
Conducted spurious emission table

No.	Frequency (MHz)	Emission Level (dBuV/m)	Limit (dBuV/m)	Margin (dB)	Raw Value (dBm)		Correction Factor (dB)	EIRP Level (dBm)
					Chain0	Chain1		
1	3698.44	66.24 PK	74	-7.76	-36.4	-37.58	4.92	-29.02
2	3704.69	45.88 AV	54	-8.12	-57.27	-57.36	4.92	-49.38
3	7356.25	64.11 PK	74	-9.89	-39.84	-38.43	4.92	-31.15
4	7389.06	43.73 AV	54	-10.27	-59.51	-59.42	4.92	-51.53
5	11048.44	65.5 PK	74	-8.5	-38.33	-37.13	4.92	-29.76
6	11042.19	44.48 AV	54	-9.52	-58.76	-58.67	4.92	-50.78
7	#16589.19	55.26 PK	68.2	-12.94	-49.26	-46.92	4.92	-40.00

Remarks:

1. Margin value = Emission Level – Limit value
2. The other emission levels were very low against the limit.
3. " # " : The frequency is out of the restricted band.



Chain 0

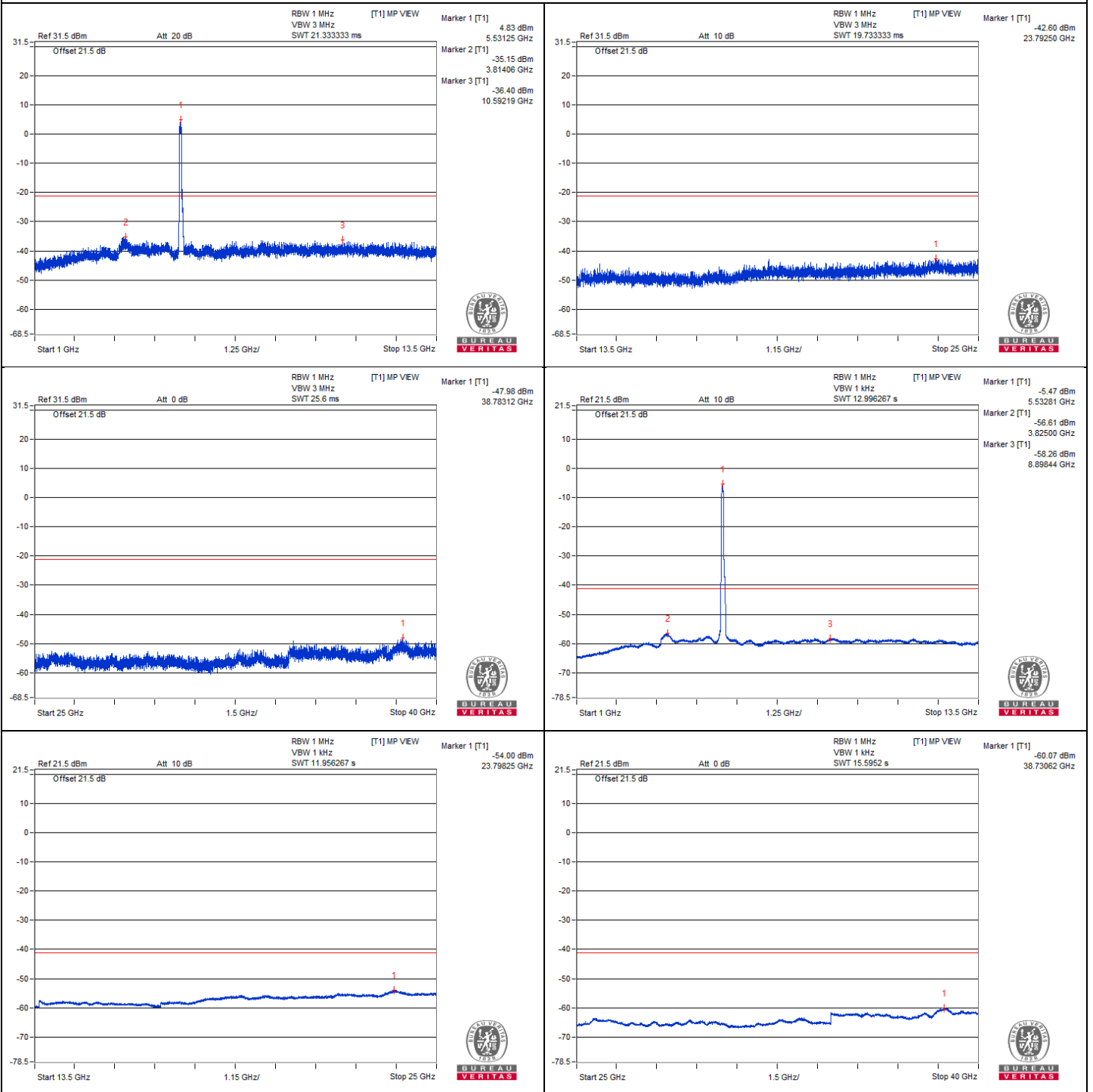



Chain 1

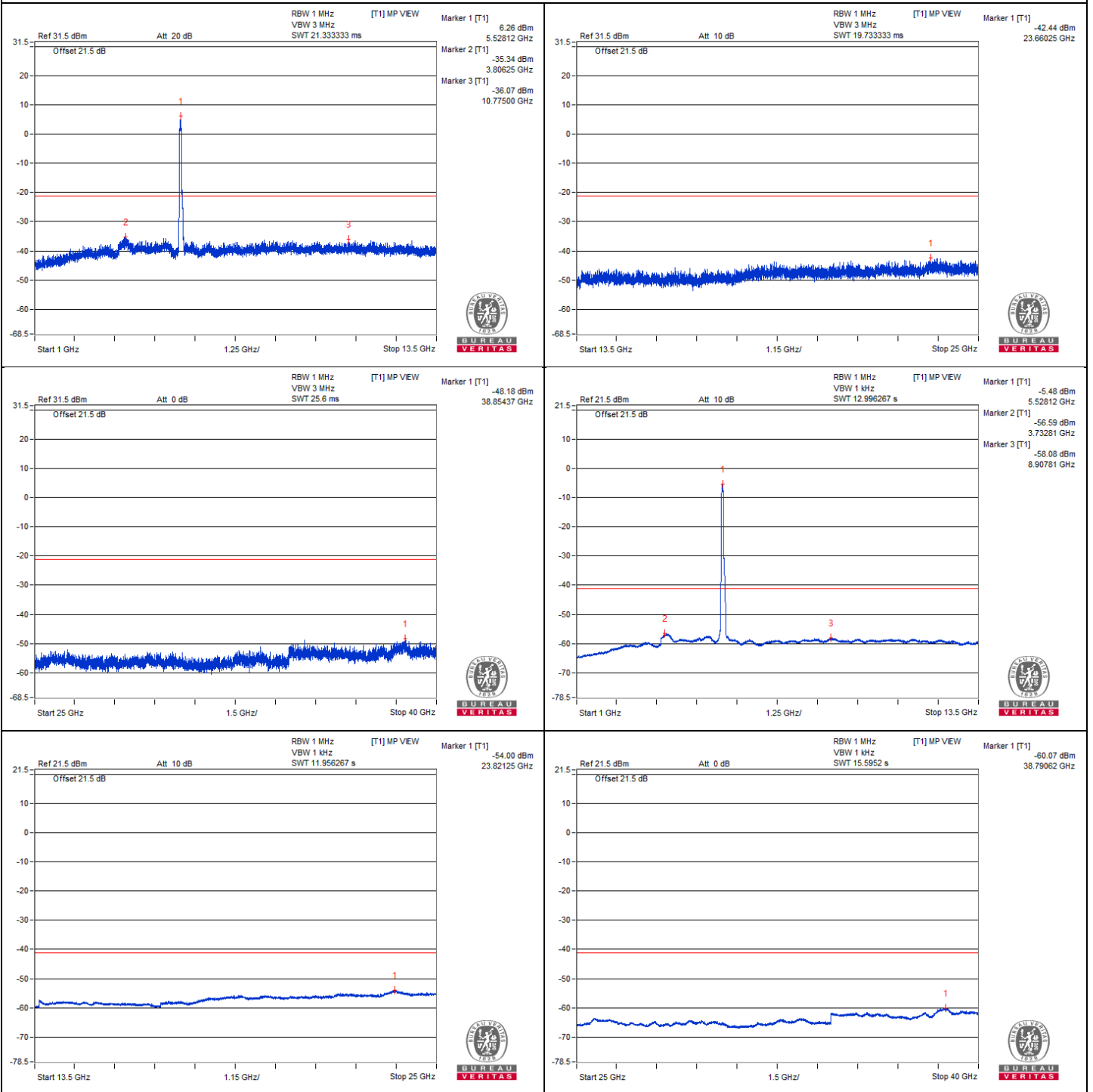

Bandedge table

No.	Frequency (MHz)	Emission Level (dBuV/m)	Limit (dBuV/m)	Margin (dB)	Raw Value (dBm)		Correction Factor (dB)	EIRP Level (dBm)
					Chain0	Chain1		
1	5443.94	62.07 PK	74	-11.93	-41.09	-41.15	4.92	-33.19
2	5459.44	51.63 AV	54	-2.37	-51.2	-51.96	4.92	-43.63
3	#5466.03	63.37 PK	68.2	-4.83	-39.1	-40.69	4.92	-31.89

Remarks:

1. Margin value = Emission Level – Limit value
2. The other emission levels were very low against the limit.

Chain 0

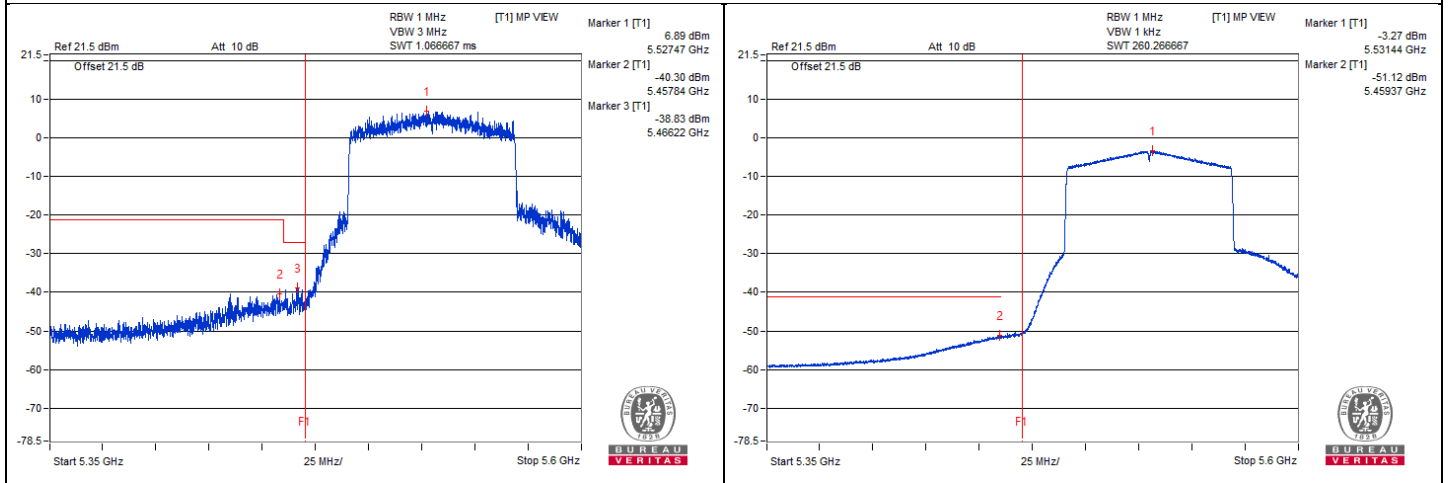

Chain 1

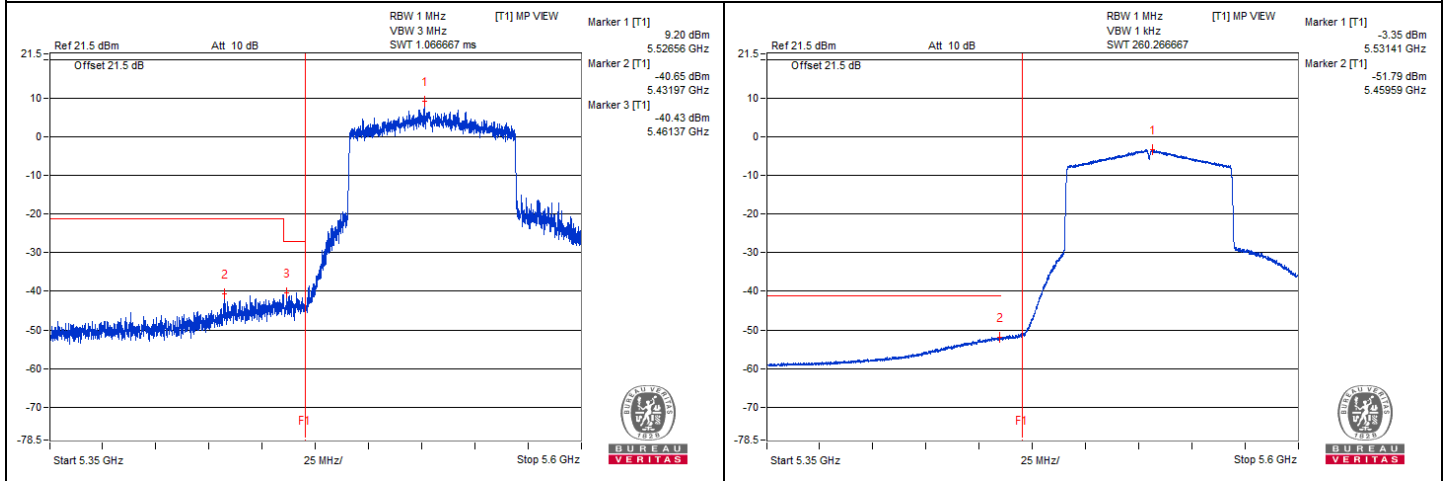

802.11be (EHT80) - Channel 122
Conducted spurious emission table

No.	Frequency (MHz)	Emission Level (dBuV/m)	Limit (dBuV/m)	Margin (dB)	Raw Value (dBm)		Correction Factor (dB)	EIRP Level (dBm)
					Chain0	Chain1		
1	3729.69	65.82 PK	74	-8.18	-37.52	-37.23	4.92	-29.44
2	3750	46.24 AV	54	-7.76	-56.94	-56.96	4.92	-49.02
3	7479.69	64.7 PK	74	-9.3	-40.07	-37.33	4.92	-30.56
4	7489.06	43.53 AV	54	-10.47	-59.36	-59.98	4.92	-51.73
5	11226.56	64.02 PK	74	-9.98	-38.72	-39.68	4.92	-31.24
6	11203.12	43.95 AV	54	-10.05	-59.31	-59.17	4.92	-51.31
7	#16824.94	54.41 PK	68.2	-13.79	-48.4	-49.19	4.92	-40.85

Remarks:

1. Margin value = Emission Level – Limit value
2. The other emission levels were very low against the limit.
3. " # " : The frequency is out of the restricted band.



Chain 0

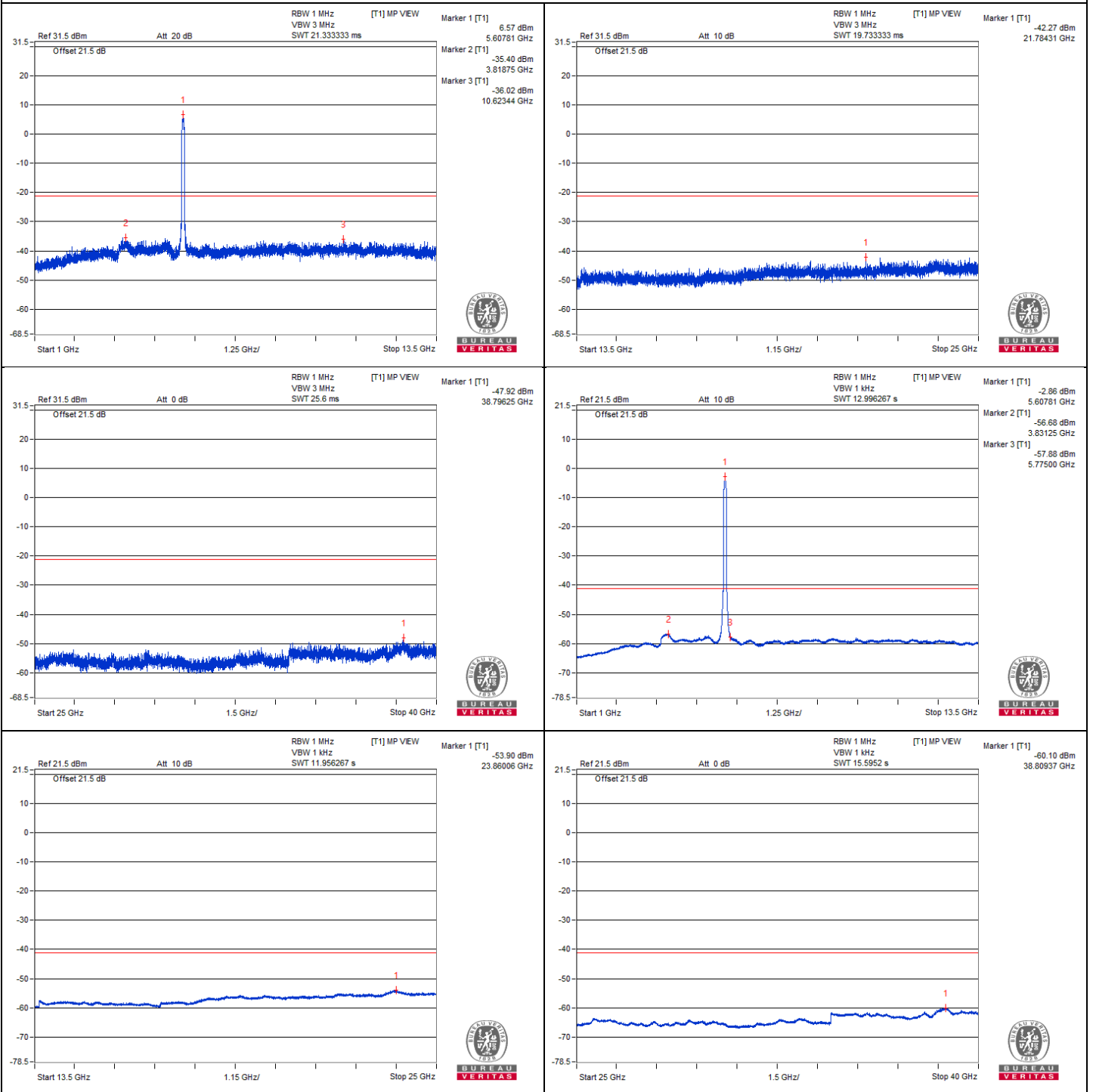



Chain 1

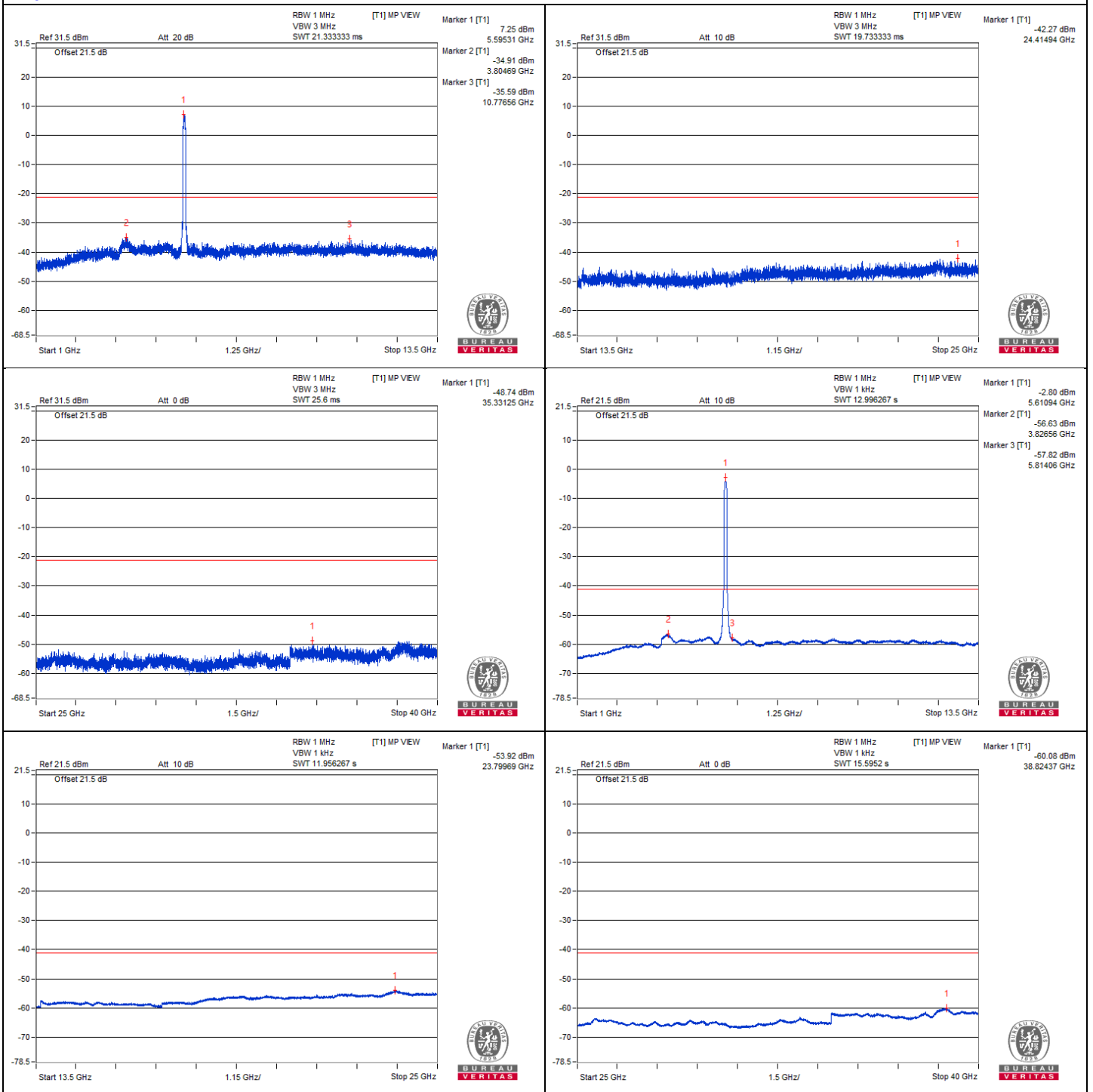

Bandedge table

No.	Frequency (MHz)	Emission Level (dBuV/m)	Limit (dBuV/m)	Margin (dB)	Raw Value (dBm)		Correction Factor (dB)	EIRP Level (dBm)
					Chain0	Chain1		
1	#5725.8	67.05 PK	68.2	-1.15	-35.43	-37	4.92	-28.21

Remarks:

1. Margin value = Emission Level – Limit value
2. The other emission levels were very low against the limit.

Chain 0

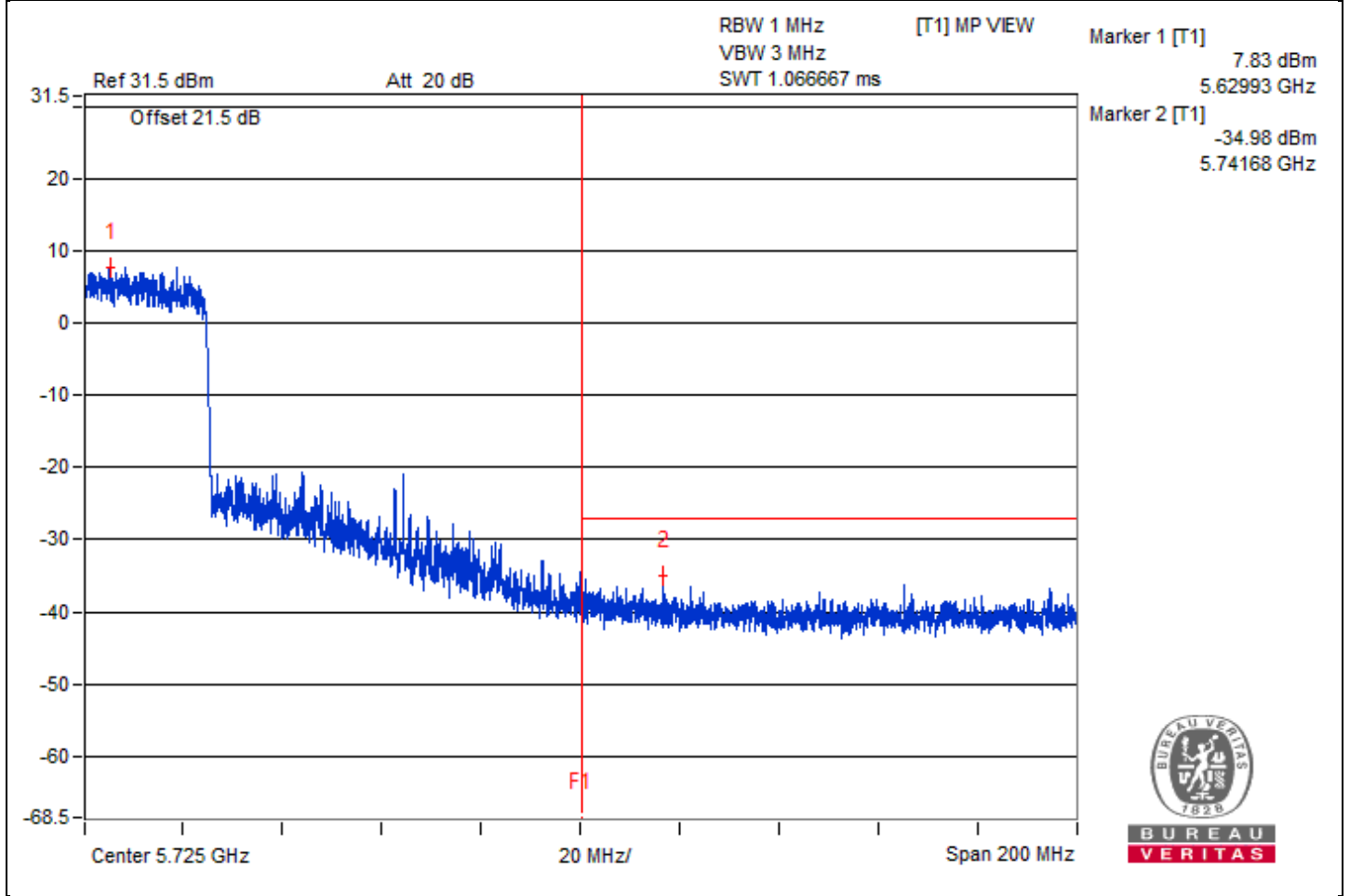



Chain 1

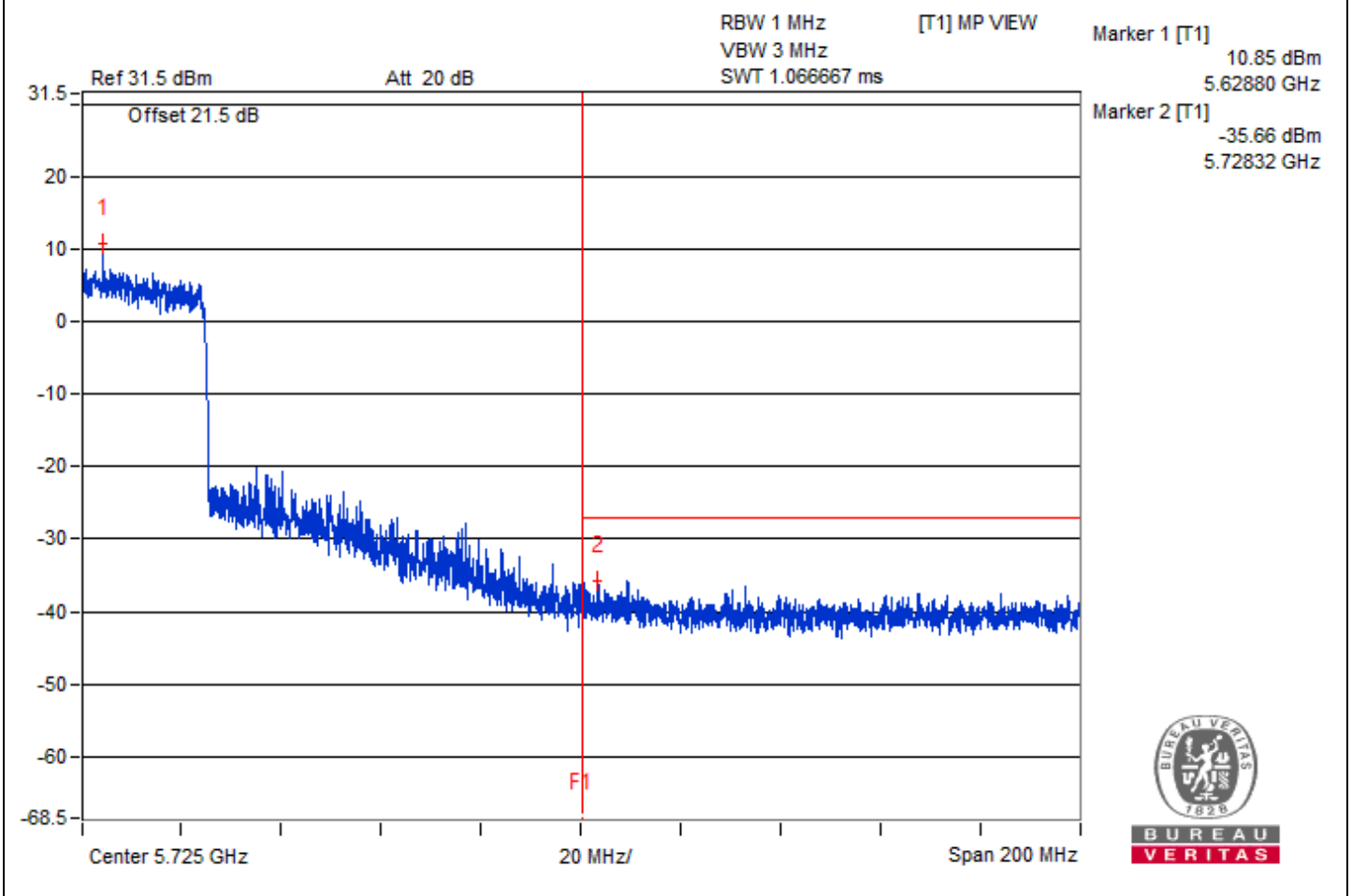

802.11be (EHT80) - Channel 138
Conducted spurious emission table

No.	Frequency (MHz)	Emission Level (dBuV/m)	Limit (dBuV/m)	Margin (dB)	Raw Value (dBm)		Correction Factor (dB)	EIRP Level (dBm)
					Chain0	Chain1		
1	3731.25	67.6 PK	74	-6.4	-36.63	-34.75	4.92	-27.66
2	3742.19	46.28 AV	54	-7.72	-57.03	-56.79	4.92	-48.98
3	7484.37	63.52 PK	74	-10.48	-40.98	-38.66	4.92	-31.74
4	7489.06	43.54 AV	54	-10.46	-59.71	-59.6	4.92	-51.72
5	11206.25	64.53 PK	74	-9.47	-39.52	-37.95	4.92	-30.73
6	11200	43.82 AV	54	-10.18	-59.38	-59.36	4.92	-51.44
7	#16845.06	54.83 PK	68.2	-13.37	-47.06	-50.22	4.92	-40.43

Remarks:

1. Margin value = Emission Level – Limit value
2. The other emission levels were very low against the limit.
3. " # " : The frequency is out of the restricted band.



Chain 0

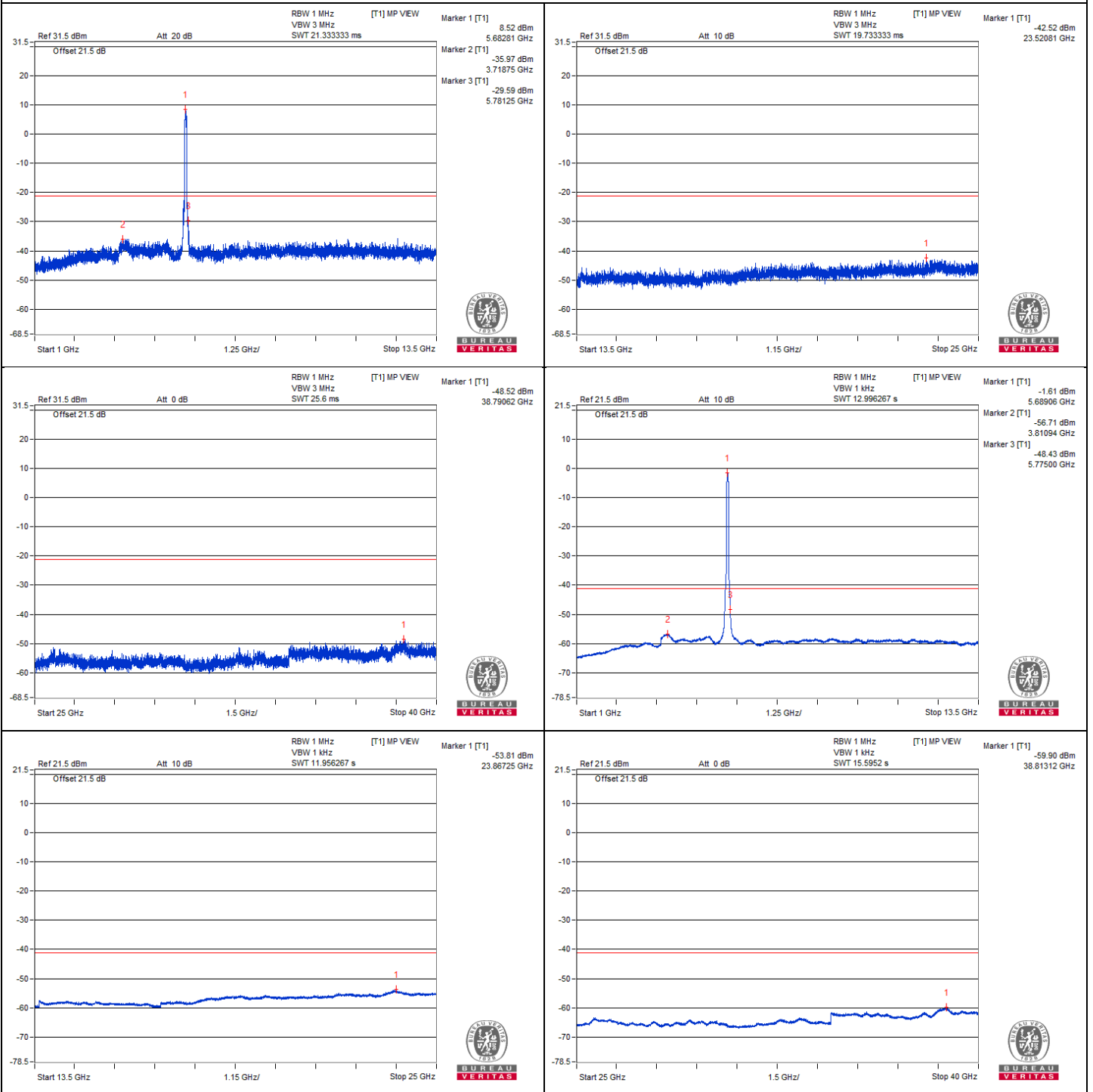



Chain 1

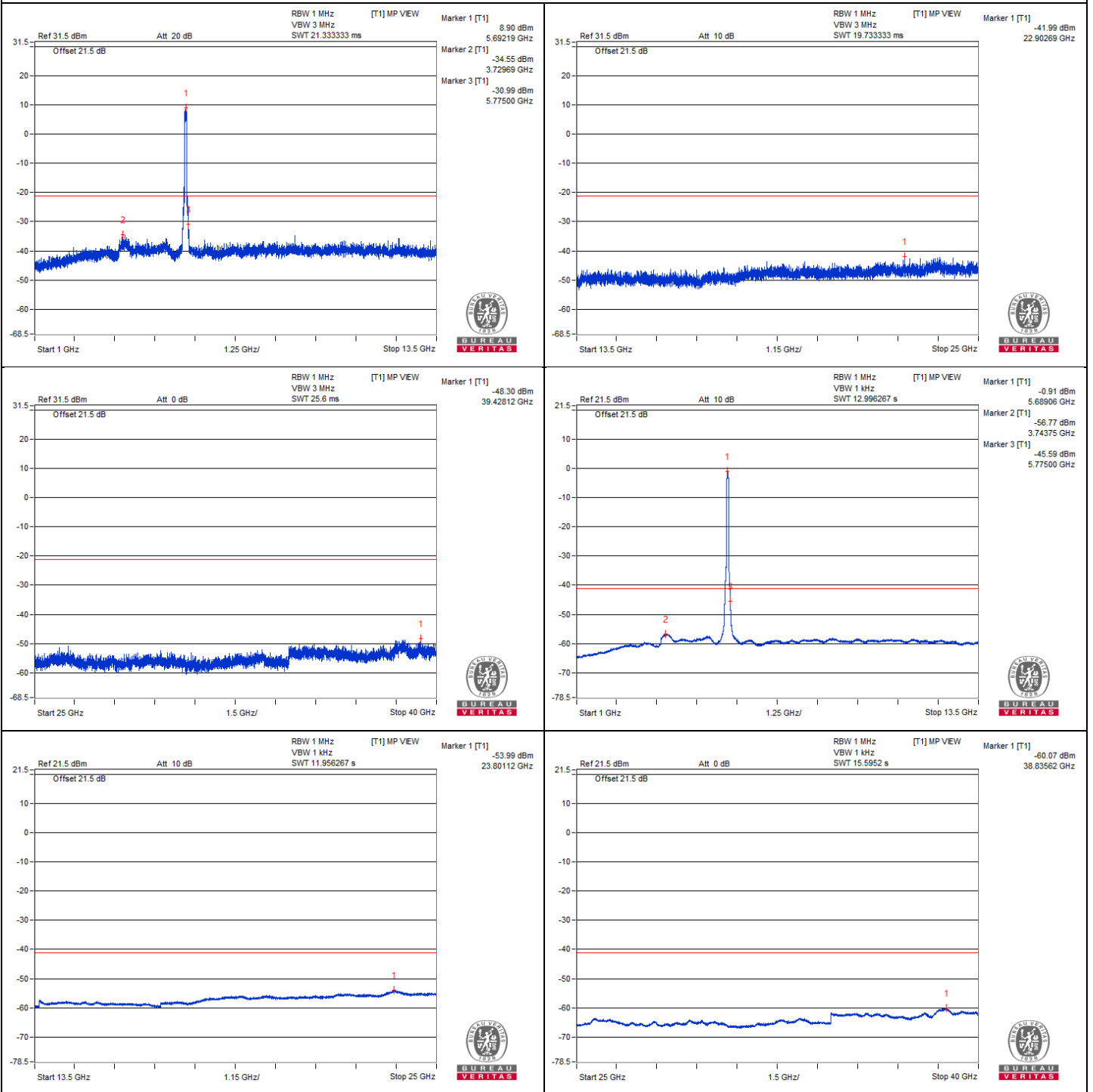



Bandedge table

No.	Frequency (MHz)	Emission Level (dBuV/m)	Limit (dBuV/m)	Margin (dB)	Raw Value (dBm)		Correction Factor (dB)	EIRP Level (dBm)
					Chain0	Chain1		
1	#5868.15	66.72 PK	68.2	-1.48	-39.49	-34.71	4.92	-28.54

Remarks:

1. Margin value = Emission Level – Limit value
2. The other emission levels were very low against the limit.

Chain 0

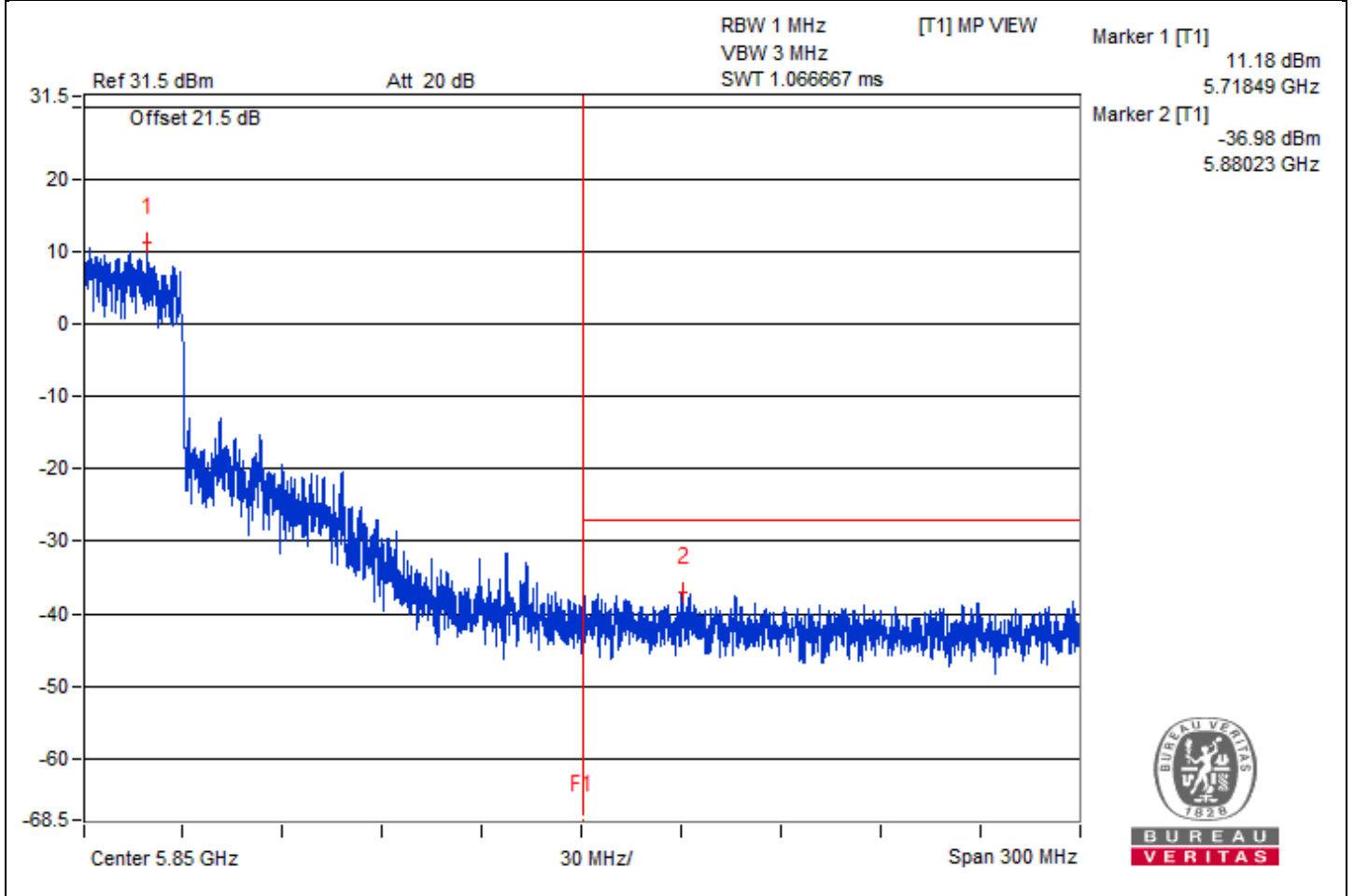



Chain 1

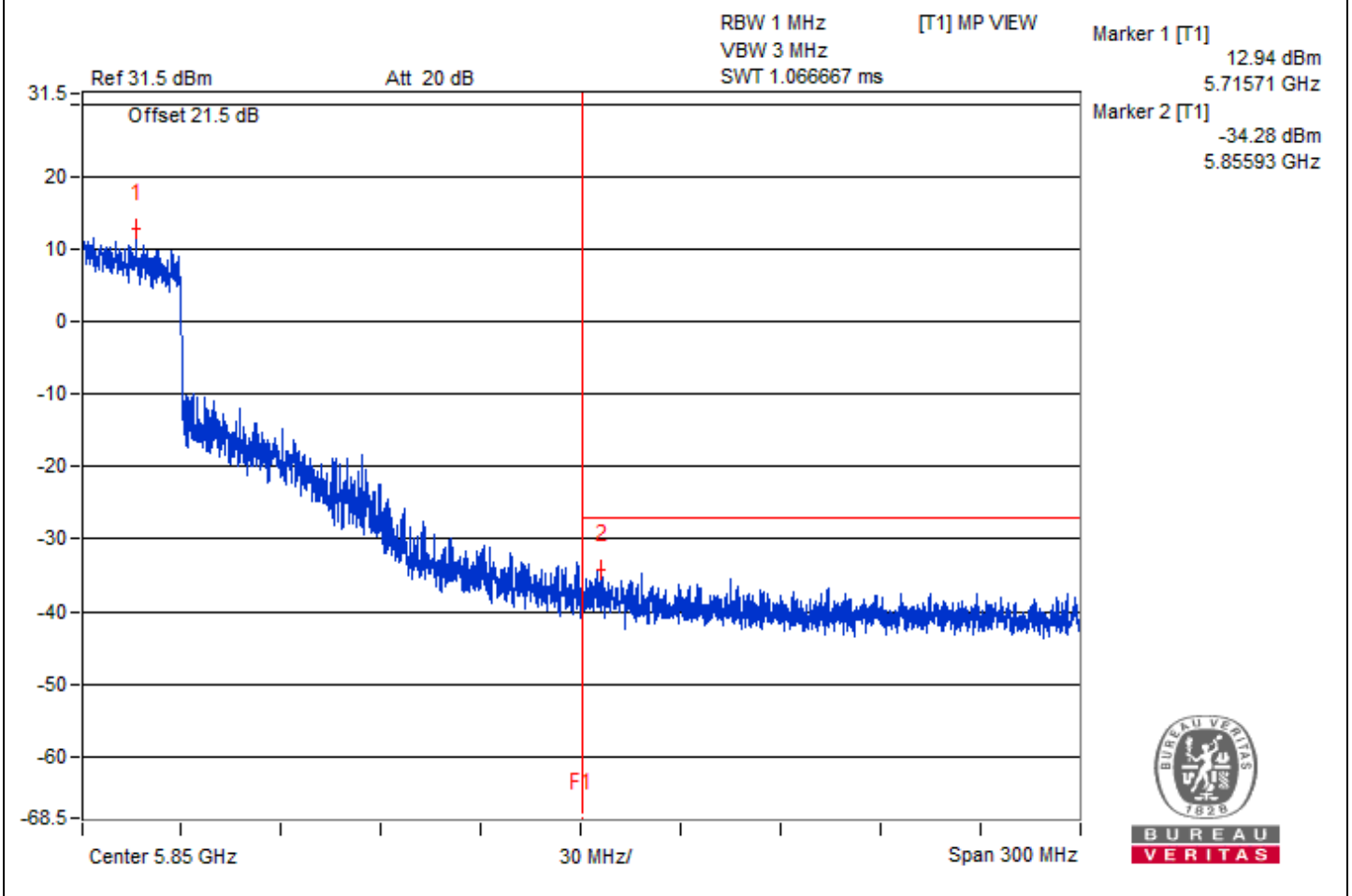

Mode B 1S1T

RF Mode	802.11be (EHT20)	Channel	CH 149 : 5745 MHz
Frequency Range	1 GHz ~ 40 GHz	Detector Function & Bandwidth	PK: RB=1 MHz, VB=3 MHz, DET=Peak AV: RB=1 MHz, VB=300 Hz, DET=Peak
Input Power (System)	120 Vac, 60 Hz	Environmental Conditions	24.0 °C, 68.0 % RH
Tested By	Sampson Chen		

Antenna Polarity & Test Distance : Horizontal at 3 m

No	Frequency (MHz)	Emission Level (dBuV/m)	Limit (dBuV/m)	Margin (dB)	Antenna Height (m)	Table Angle (Degree)	Raw Value (dBuV)	Correction Factor (dB/m)
1	11490.00	48.2 PK	74.0	-25.8	3.67 H	75	31.3	16.9
2	11490.00	37.2 AV	54.0	-16.8	3.67 H	75	20.3	16.9
3	#17235.00	49.3 PK	68.2	-18.9	1.58 H	80	29.2	20.1

Remarks:

1. Emission Level(dBuV/m) = Raw Value(dBuV) + Correction Factor(dB/m)
2. Correction Factor(dB/m) = Antenna Factor(dB/m) + Cable Factor(dB) – Pre-Amplifier Factor(dB)
3. Margin value = Emission Level – Limit value
4. The other emission levels were very low against the limit.
5. "#": The radiated frequency is out of the restricted band.

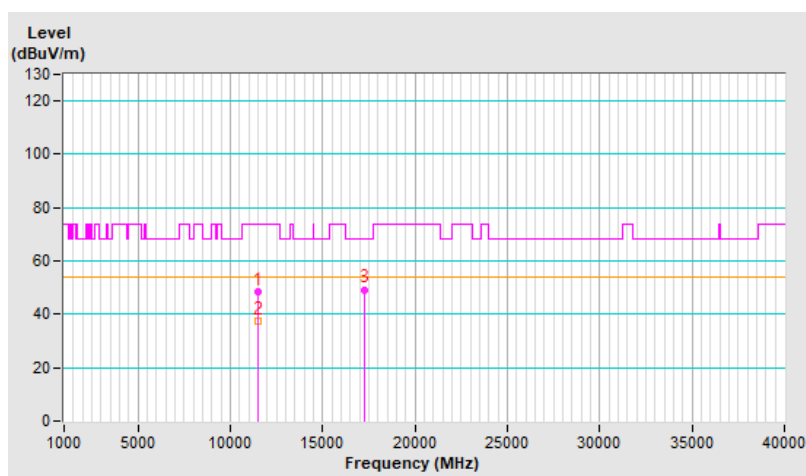

RF Mode	802.11be (EHT20)	Channel	CH 149 : 5745 MHz
Frequency Range	1 GHz ~ 40 GHz	Detector Function & Bandwidth	PK: RB=1 MHz, VB=3 MHz, DET=Peak AV: RB=1 MHz, VB=300 Hz, DET=Peak
Input Power (System)	120 Vac, 60 Hz	Environmental Conditions	24.0 °C, 68.0 % RH
Tested By	Sampson Chen		

Antenna Polarity & Test Distance : Vertical at 3 m								
No	Frequency (MHz)	Emission Level (dBuV/m)	Limit (dBuV/m)	Margin (dB)	Antenna Height (m)	Table Angle (Degree)	Raw Value (dBuV)	Correction Factor (dB/m)
1	11490.00	50.0 PK	74.0	-24.0	2.59 V	233	33.1	16.9
2	11490.00	40.6 AV	54.0	-13.4	2.59 V	233	23.7	16.9
3	#17235.00	49.6 PK	68.2	-18.6	1.28 V	56	29.5	20.1

Remarks:

1. Emission Level(dBuV/m) = Raw Value(dBuV) + Correction Factor(dB/m)
2. Correction Factor(dB/m) = Antenna Factor(dB/m) + Cable Factor(dB) – Pre-Amplifier Factor(dB)
3. Margin value = Emission Level – Limit value
4. The other emission levels were very low against the limit.
5. "#": The radiated frequency is out of the restricted band.

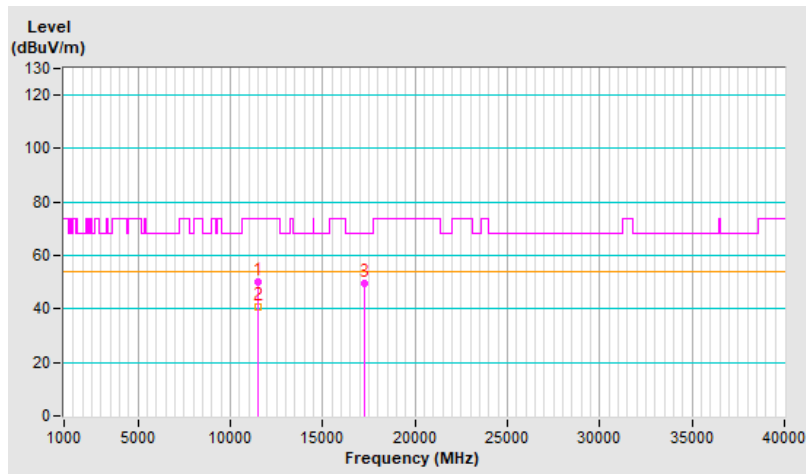

RF Mode	802.11be (EHT20)	Channel	CH 157 : 5785 MHz
Frequency Range	1 GHz ~ 40 GHz	Detector Function & Bandwidth	PK: RB=1 MHz, VB=3 MHz, DET=Peak AV: RB=1 MHz, VB=300 Hz, DET=Peak
Input Power (System)	120 Vac, 60 Hz	Environmental Conditions	24.0 °C, 68.0 % RH
Tested By	Sampson Chen		

Antenna Polarity & Test Distance : Horizontal at 3 m								
No	Frequency (MHz)	Emission Level (dBuV/m)	Limit (dBuV/m)	Margin (dB)	Antenna Height (m)	Table Angle (Degree)	Raw Value (dBuV)	Correction Factor (dB/m)
1	11570.00	48.5 PK	74.0	-25.5	3.65 H	60	31.5	17.0
2	11570.00	36.7 AV	54.0	-17.3	3.65 H	60	19.7	17.0
3	#17355.00	49.1 PK	68.2	-19.1	1.55 H	95	28.0	21.1

Remarks:

1. Emission Level(dBuV/m) = Raw Value(dBuV) + Correction Factor(dB/m)
2. Correction Factor(dB/m) = Antenna Factor(dB/m) + Cable Factor(dB) – Pre-Amplifier Factor(dB)
3. Margin value = Emission Level – Limit value
4. The other emission levels were very low against the limit.
5. "#": The radiated frequency is out of the restricted band.

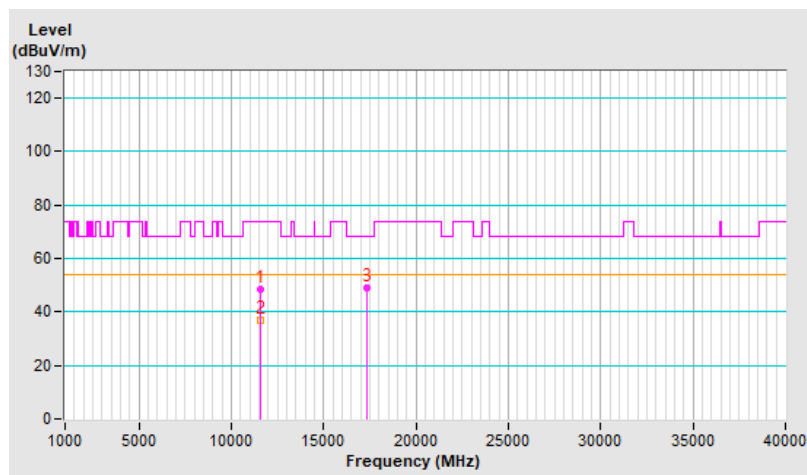

RF Mode	802.11be (EHT20)	Channel	CH 157 : 5785 MHz
Frequency Range	1 GHz ~ 40 GHz	Detector Function & Bandwidth	PK: RB=1 MHz, VB=3 MHz, DET=Peak AV: RB=1 MHz, VB=300 Hz, DET=Peak
Input Power (System)	120 Vac, 60 Hz	Environmental Conditions	24.0 °C, 68.0 % RH
Tested By	Sampson Chen		

Antenna Polarity & Test Distance : Vertical at 3 m								
No	Frequency (MHz)	Emission Level (dBuV/m)	Limit (dBuV/m)	Margin (dB)	Antenna Height (m)	Table Angle (Degree)	Raw Value (dBuV)	Correction Factor (dB/m)
1	11570.00	49.8 PK	74.0	-24.2	2.64 V	233	32.8	17.0
2	11570.00	40.7 AV	54.0	-13.3	2.64 V	233	23.7	17.0
3	#17355.00	51.0 PK	68.2	-17.2	1.23 V	54	29.9	21.1

Remarks:

1. Emission Level(dBuV/m) = Raw Value(dBuV) + Correction Factor(dB/m)
2. Correction Factor(dB/m) = Antenna Factor(dB/m) + Cable Factor(dB) – Pre-Amplifier Factor(dB)
3. Margin value = Emission Level – Limit value
4. The other emission levels were very low against the limit.
5. "#": The radiated frequency is out of the restricted band.

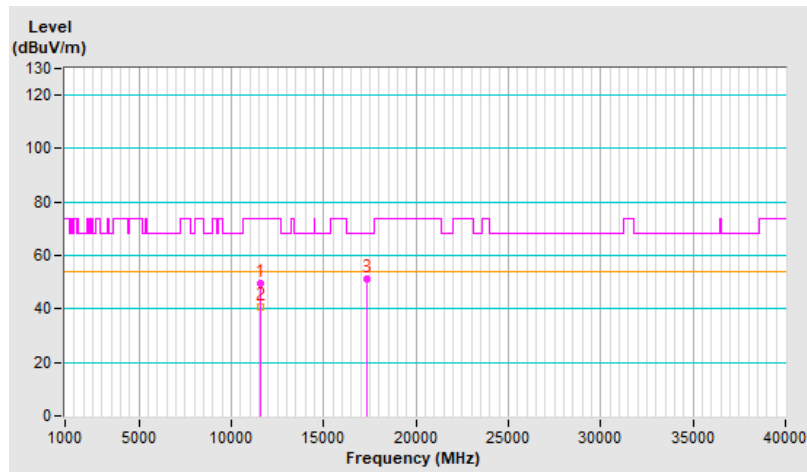

RF Mode	802.11be (EHT20)	Channel	CH 165 : 5825 MHz
Frequency Range	1 GHz ~ 40 GHz	Detector Function & Bandwidth	PK: RB=1 MHz, VB=3 MHz, DET=Peak AV: RB=1 MHz, VB=300 Hz, DET=Peak
Input Power (System)	120 Vac, 60 Hz	Environmental Conditions	24.0 °C, 68.0 % RH
Tested By	Sampson Chen		

Antenna Polarity & Test Distance : Horizontal at 3 m								
No	Frequency (MHz)	Emission Level (dBuV/m)	Limit (dBuV/m)	Margin (dB)	Antenna Height (m)	Table Angle (Degree)	Raw Value (dBuV)	Correction Factor (dB/m)
1	11650.00	49.5 PK	74.0	-24.5	3.63 H	79	32.6	16.9
2	11650.00	37.4 AV	54.0	-16.6	3.63 H	79	20.5	16.9
3	#17475.00	48.9 PK	68.2	-19.3	1.54 H	84	26.5	22.4

Remarks:

1. Emission Level(dBuV/m) = Raw Value(dBuV) + Correction Factor(dB/m)
2. Correction Factor(dB/m) = Antenna Factor(dB/m) + Cable Factor(dB) – Pre-Amplifier Factor(dB)
3. Margin value = Emission Level – Limit value
4. The other emission levels were very low against the limit.
5. "#": The radiated frequency is out of the restricted band.

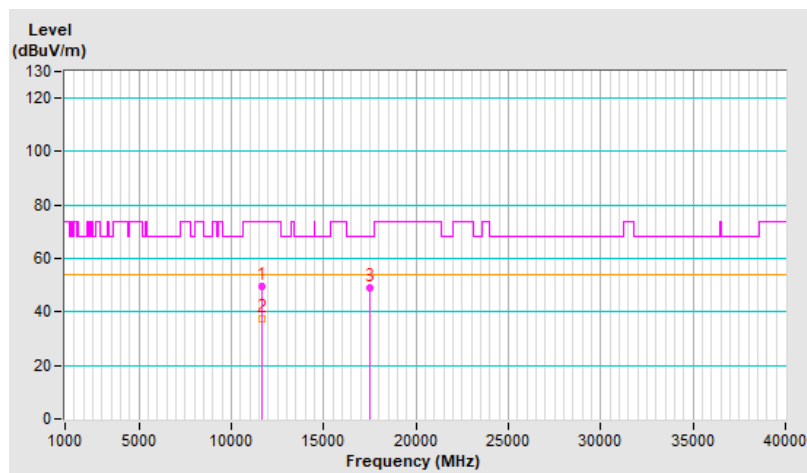

RF Mode	802.11be (EHT20)	Channel	CH 165 : 5825 MHz
Frequency Range	1 GHz ~ 40 GHz	Detector Function & Bandwidth	PK: RB=1 MHz, VB=3 MHz, DET=Peak AV: RB=1 MHz, VB=300 Hz, DET=Peak
Input Power (System)	120 Vac, 60 Hz	Environmental Conditions	24.0 °C, 68.0 % RH
Tested By	Sampson Chen		

Antenna Polarity & Test Distance : Vertical at 3 m								
No	Frequency (MHz)	Emission Level (dBuV/m)	Limit (dBuV/m)	Margin (dB)	Antenna Height (m)	Table Angle (Degree)	Raw Value (dBuV)	Correction Factor (dB/m)
1	11650.00	50.9 PK	74.0	-23.1	2.63 V	245	34.0	16.9
2	11650.00	41.9 AV	54.0	-12.1	2.63 V	245	25.0	16.9
3	#17475.00	50.8 PK	68.2	-17.4	1.25 V	46	28.4	22.4

Remarks:

1. Emission Level(dBuV/m) = Raw Value(dBuV) + Correction Factor(dB/m)
2. Correction Factor(dB/m) = Antenna Factor(dB/m) + Cable Factor(dB) – Pre-Amplifier Factor(dB)
3. Margin value = Emission Level – Limit value
4. The other emission levels were very low against the limit.
5. " # " : The radiated frequency is out of the restricted band.

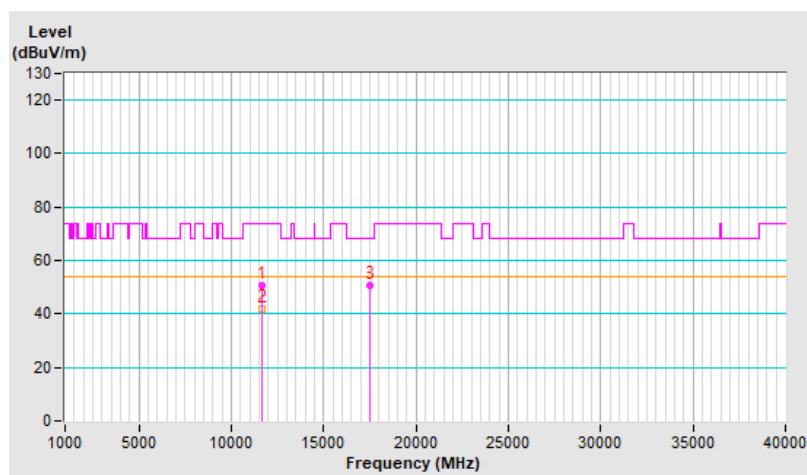

RF Mode	802.11be (EHT40)	Channel	CH 38 : 5190 MHz
Frequency Range	1 GHz ~ 40 GHz	Detector Function & Bandwidth	PK: RB=1 MHz, VB=3 MHz, DET=Peak AV: RB=1 MHz, VB=300 Hz, DET=Peak
Input Power (System)	120 Vac, 60 Hz	Environmental Conditions	24.0 °C, 68.0 % RH
Tested By	Sampson Chen		

Antenna Polarity & Test Distance : Horizontal at 3 m								
No	Frequency (MHz)	Emission Level (dBuV/m)	Limit (dBuV/m)	Margin (dB)	Antenna Height (m)	Table Angle (Degree)	Raw Value (dBuV)	Correction Factor (dB/m)
1	#10380.00	50.5 PK	68.2	-17.7	3.66 H	68	34.5	16.0
2	15570.00	51.5 PK	74.0	-22.5	1.59 H	81	34.6	16.9
3	15570.00	40.4 AV	54.0	-13.6	1.59 H	81	23.5	16.9

Remarks:

1. Emission Level(dBuV/m) = Raw Value(dBuV) + Correction Factor(dB/m)
2. Correction Factor(dB/m) = Antenna Factor(dB/m) + Cable Factor(dB) – Pre-Amplifier Factor(dB)
3. Margin value = Emission Level – Limit value
4. The other emission levels were very low against the limit.
5. " # " : The radiated frequency is out of the restricted band.

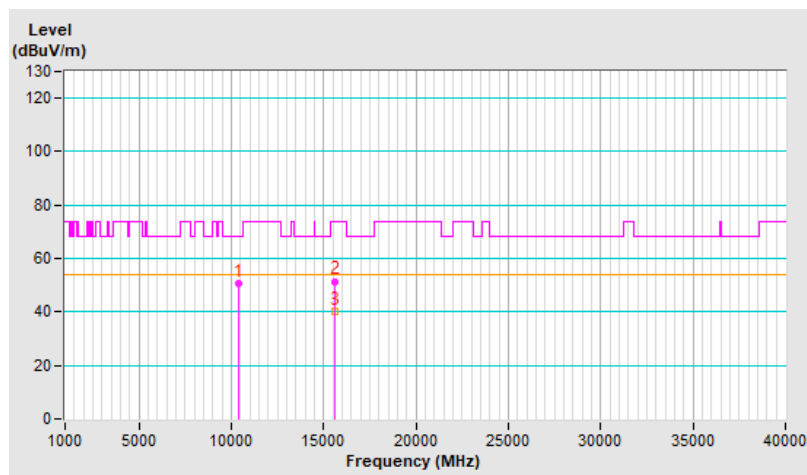

RF Mode	802.11be (EHT40)	Channel	CH 38 : 5190 MHz
Frequency Range	1 GHz ~ 40 GHz	Detector Function & Bandwidth	PK: RB=1 MHz, VB=3 MHz, DET=Peak AV: RB=1 MHz, VB=300 Hz, DET=Peak
Input Power (System)	120 Vac, 60 Hz	Environmental Conditions	24.0 °C, 68.0 % RH
Tested By	Sampson Chen		

Antenna Polarity & Test Distance : Vertical at 3 m								
No	Frequency (MHz)	Emission Level (dBuV/m)	Limit (dBuV/m)	Margin (dB)	Antenna Height (m)	Table Angle (Degree)	Raw Value (dBuV)	Correction Factor (dB/m)
1	#10380.00	50.1 PK	68.2	-18.1	2.57 V	217	34.1	16.0
2	15570.00	49.9 PK	74.0	-24.1	1.33 V	70	33.0	16.9
3	15570.00	40.4 AV	54.0	-13.6	1.33 V	70	23.5	16.9

Remarks:

1. Emission Level(dBuV/m) = Raw Value(dBuV) + Correction Factor(dB/m)
2. Correction Factor(dB/m) = Antenna Factor(dB/m) + Cable Factor(dB) – Pre-Amplifier Factor(dB)
3. Margin value = Emission Level – Limit value
4. The other emission levels were very low against the limit.
5. " # " : The radiated frequency is out of the restricted band.

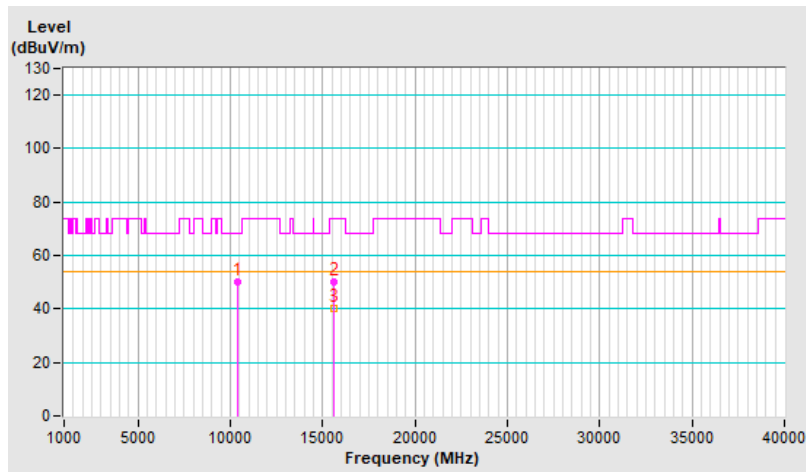

RF Mode	802.11be (EHT40)	Channel	CH 46 : 5230 MHz
Frequency Range	1 GHz ~ 40 GHz	Detector Function & Bandwidth	PK: RB=1 MHz, VB=3 MHz, DET=Peak AV: RB=1 MHz, VB=300 Hz, DET=Peak
Input Power (System)	120 Vac, 60 Hz	Environmental Conditions	24.0 °C, 68.0 % RH
Tested By	Sampson Chen		

Antenna Polarity & Test Distance : Horizontal at 3 m								
No	Frequency (MHz)	Emission Level (dBuV/m)	Limit (dBuV/m)	Margin (dB)	Antenna Height (m)	Table Angle (Degree)	Raw Value (dBuV)	Correction Factor (dB/m)
1	#10460.00	48.5 PK	68.2	-19.7	3.68 H	85	32.5	16.0
2	15690.00	51.2 PK	74.0	-22.8	1.53 H	85	34.0	17.2
3	15690.00	39.0 AV	54.0	-15.0	1.53 H	85	21.8	17.2

Remarks:

1. Emission Level(dBuV/m) = Raw Value(dBuV) + Correction Factor(dB/m)
2. Correction Factor(dB/m) = Antenna Factor(dB/m) + Cable Factor(dB) – Pre-Amplifier Factor(dB)
3. Margin value = Emission Level – Limit value
4. The other emission levels were very low against the limit.
5. "#": The radiated frequency is out of the restricted band.

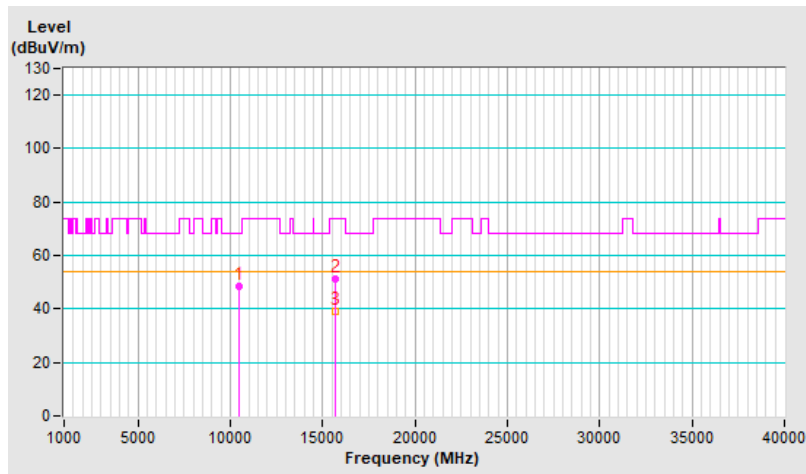

RF Mode	802.11be (EHT40)	Channel	CH 46 : 5230 MHz
Frequency Range	1 GHz ~ 40 GHz	Detector Function & Bandwidth	PK: RB=1 MHz, VB=3 MHz, DET=Peak AV: RB=1 MHz, VB=300 Hz, DET=Peak
Input Power (System)	120 Vac, 60 Hz	Environmental Conditions	24.0 °C, 68.0 % RH
Tested By	Sampson Chen		

Antenna Polarity & Test Distance : Vertical at 3 m								
No	Frequency (MHz)	Emission Level (dBuV/m)	Limit (dBuV/m)	Margin (dB)	Antenna Height (m)	Table Angle (Degree)	Raw Value (dBuV)	Correction Factor (dB/m)
1	#10460.00	49.8 PK	68.2	-18.4	2.62 V	224	33.8	16.0
2	15690.00	51.1 PK	74.0	-22.9	1.22 V	62	33.9	17.2
3	15690.00	38.7 AV	54.0	-15.3	1.22 V	62	21.5	17.2

Remarks:

1. Emission Level(dBuV/m) = Raw Value(dBuV) + Correction Factor(dB/m)
2. Correction Factor(dB/m) = Antenna Factor(dB/m) + Cable Factor(dB) – Pre-Amplifier Factor(dB)
3. Margin value = Emission Level – Limit value
4. The other emission levels were very low against the limit.
5. " # " : The radiated frequency is out of the restricted band.

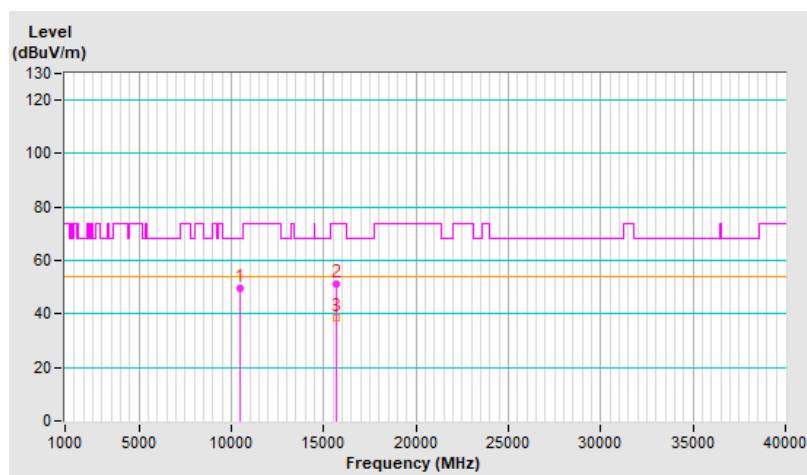

RF Mode	802.11be (EHT40)	Channel	CH 54 : 5270 MHz
Frequency Range	1 GHz ~ 40 GHz	Detector Function & Bandwidth	PK: RB=1 MHz, VB=3 MHz, DET=Peak AV: RB=1 MHz, VB=300 Hz, DET=Peak
Input Power (System)	120 Vac, 60 Hz	Environmental Conditions	24.0 °C, 68.0 % RH
Tested By	Sampson Chen		

Antenna Polarity & Test Distance : Horizontal at 3 m								
No	Frequency (MHz)	Emission Level (dBuV/m)	Limit (dBuV/m)	Margin (dB)	Antenna Height (m)	Table Angle (Degree)	Raw Value (dBuV)	Correction Factor (dB/m)
1	#10540.00	48.9 PK	68.2	-19.3	3.66 H	61	32.8	16.1
2	15810.00	50.3 PK	74.0	-23.7	1.62 H	84	33.2	17.1
3	15810.00	40.8 AV	54.0	-13.2	1.62 H	84	23.7	17.1

Remarks:

1. Emission Level(dBuV/m) = Raw Value(dBuV) + Correction Factor(dB/m)
2. Correction Factor(dB/m) = Antenna Factor(dB/m) + Cable Factor(dB) – Pre-Amplifier Factor(dB)
3. Margin value = Emission Level – Limit value
4. The other emission levels were very low against the limit.
5. " # " : The radiated frequency is out of the restricted band.

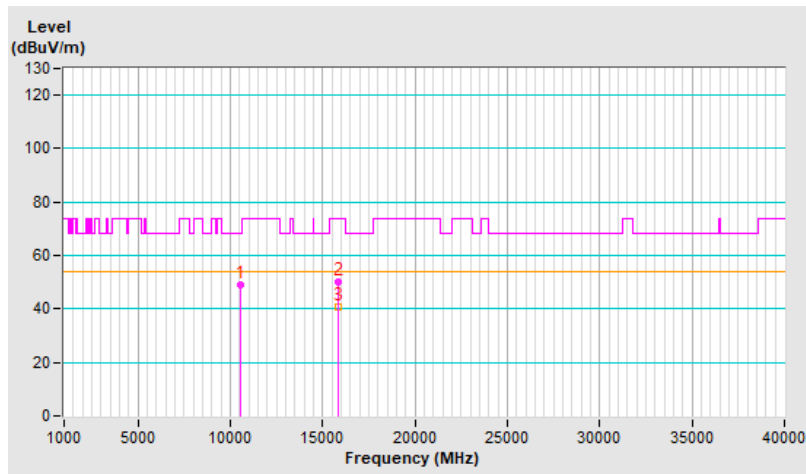

RF Mode	802.11be (EHT40)	Channel	CH 54 : 5270 MHz
Frequency Range	1 GHz ~ 40 GHz	Detector Function & Bandwidth	PK: RB=1 MHz, VB=3 MHz, DET=Peak AV: RB=1 MHz, VB=300 Hz, DET=Peak
Input Power (System)	120 Vac, 60 Hz	Environmental Conditions	24.0 °C, 68.0 % RH
Tested By	Sampson Chen		

Antenna Polarity & Test Distance : Vertical at 3 m								
No	Frequency (MHz)	Emission Level (dBuV/m)	Limit (dBuV/m)	Margin (dB)	Antenna Height (m)	Table Angle (Degree)	Raw Value (dBuV)	Correction Factor (dB/m)
1	#10540.00	50.6 PK	68.2	-17.6	2.63 V	237	34.5	16.1
2	15810.00	51.8 PK	74.0	-22.2	1.23 V	53	34.7	17.1
3	15810.00	40.6 AV	54.0	-13.4	1.23 V	53	23.5	17.1

Remarks:

1. Emission Level(dBuV/m) = Raw Value(dBuV) + Correction Factor(dB/m)
2. Correction Factor(dB/m) = Antenna Factor(dB/m) + Cable Factor(dB) – Pre-Amplifier Factor(dB)
3. Margin value = Emission Level – Limit value
4. The other emission levels were very low against the limit.
5. " # " : The radiated frequency is out of the restricted band.

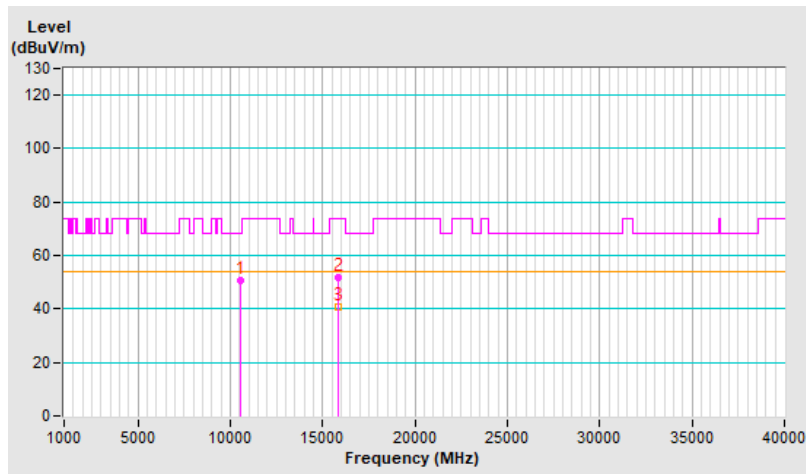

RF Mode	802.11be (EHT40)	Channel	CH 62 : 5310 MHz
Frequency Range	1 GHz ~ 40 GHz	Detector Function & Bandwidth	PK: RB=1 MHz, VB=3 MHz, DET=Peak AV: RB=1 MHz, VB=300 Hz, DET=Peak
Input Power (System)	120 Vac, 60 Hz	Environmental Conditions	24.0 °C, 68.0 % RH
Tested By	Sampson Chen		

Antenna Polarity & Test Distance : Horizontal at 3 m								
No	Frequency (MHz)	Emission Level (dBuV/m)	Limit (dBuV/m)	Margin (dB)	Antenna Height (m)	Table Angle (Degree)	Raw Value (dBuV)	Correction Factor (dB/m)
1	10620.00	49.6 PK	74.0	-24.4	3.63 H	61	33.2	16.4
2	10620.00	37.6 AV	54.0	-16.4	3.63 H	61	21.2	16.4
3	15930.00	51.2 PK	74.0	-22.8	1.61 H	73	33.9	17.3
4	15930.00	41.1 AV	54.0	-12.9	1.61 H	73	23.8	17.3

Remarks:

1. Emission Level(dBuV/m) = Raw Value(dBuV) + Correction Factor(dB/m)
2. Correction Factor(dB/m) = Antenna Factor(dB/m) + Cable Factor(dB) – Pre-Amplifier Factor(dB)
3. Margin value = Emission Level – Limit value
4. The other emission levels were very low against the limit.

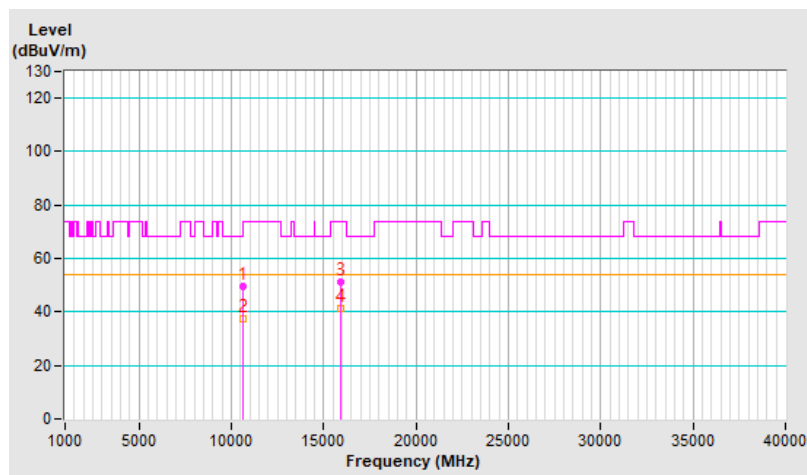

RF Mode	802.11be (EHT40)	Channel	CH 62 : 5310 MHz
Frequency Range	1 GHz ~ 40 GHz	Detector Function & Bandwidth	PK: RB=1 MHz, VB=3 MHz, DET=Peak AV: RB=1 MHz, VB=300 Hz, DET=Peak
Input Power (System)	120 Vac, 60 Hz	Environmental Conditions	24.0 °C, 68.0 % RH
Tested By	Sampson Chen		

Antenna Polarity & Test Distance : Vertical at 3 m								
No	Frequency (MHz)	Emission Level (dBuV/m)	Limit (dBuV/m)	Margin (dB)	Antenna Height (m)	Table Angle (Degree)	Raw Value (dBuV)	Correction Factor (dB/m)
1	10620.00	51.6 PK	74.0	-22.4	2.54 V	220	35.2	16.4
2	10620.00	42.6 AV	54.0	-11.4	2.54 V	220	26.2	16.4
3	15930.00	50.1 PK	74.0	-23.9	1.33 V	44	32.8	17.3
4	15930.00	39.6 AV	54.0	-14.4	1.33 V	44	22.3	17.3

Remarks:

1. Emission Level(dBuV/m) = Raw Value(dBuV) + Correction Factor(dB/m)
2. Correction Factor(dB/m) = Antenna Factor(dB/m) + Cable Factor(dB) – Pre-Amplifier Factor(dB)
3. Margin value = Emission Level – Limit value
4. The other emission levels were very low against the limit.

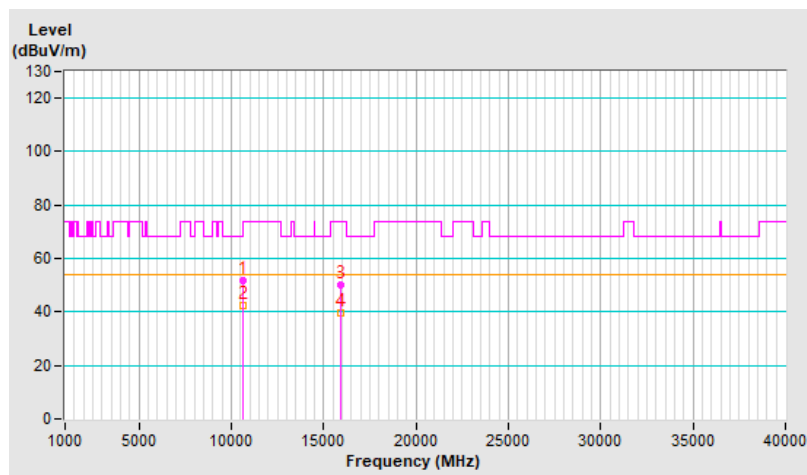

RF Mode	802.11be (EHT80)	Channel	CH 106 : 5530 MHz
Frequency Range	1 GHz ~ 40 GHz	Detector Function & Bandwidth	PK: RB=1 MHz, VB=3 MHz, DET=Peak AV: RB=1 MHz, VB=1 kHz, DET=Peak
Input Power (System)	120 Vac, 60 Hz	Environmental Conditions	24.0 °C, 68.0 % RH
Tested By	Sampson Chen		

Antenna Polarity & Test Distance : Horizontal at 3 m								
No	Frequency (MHz)	Emission Level (dBuV/m)	Limit (dBuV/m)	Margin (dB)	Antenna Height (m)	Table Angle (Degree)	Raw Value (dBuV)	Correction Factor (dB/m)
1	11060.00	47.9 PK	74.0	-26.1	3.73 H	91	31.0	16.9
2	11060.00	38.6 AV	54.0	-15.4	3.73 H	91	21.7	16.9
3	#16590.00	49.9 PK	68.2	-18.3	1.57 H	86	29.5	20.4

Remarks:

1. Emission Level(dBuV/m) = Raw Value(dBuV) + Correction Factor(dB/m)
2. Correction Factor(dB/m) = Antenna Factor(dB/m) + Cable Factor(dB) – Pre-Amplifier Factor(dB)
3. Margin value = Emission Level – Limit value
4. The other emission levels were very low against the limit.
5. "#": The radiated frequency is out of the restricted band.

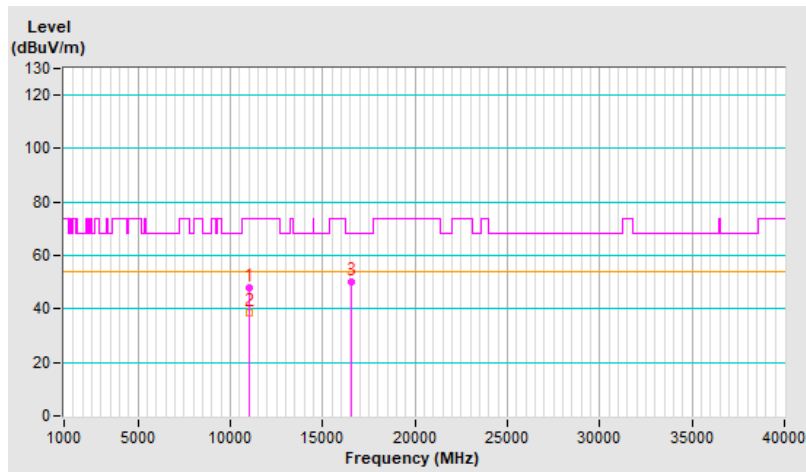

RF Mode	802.11be (EHT80)	Channel	CH 106 : 5530 MHz
Frequency Range	1 GHz ~ 40 GHz	Detector Function & Bandwidth	PK: RB=1 MHz, VB=3 MHz, DET=Peak AV: RB=1 MHz, VB=1 kHz, DET=Peak
Input Power (System)	120 Vac, 60 Hz	Environmental Conditions	24.0 °C, 68.0 % RH
Tested By	Sampson Chen		

Antenna Polarity & Test Distance : Vertical at 3 m								
No	Frequency (MHz)	Emission Level (dBuV/m)	Limit (dBuV/m)	Margin (dB)	Antenna Height (m)	Table Angle (Degree)	Raw Value (dBuV)	Correction Factor (dB/m)
1	11060.00	52.5 PK	74.0	-21.5	2.59 V	224	35.6	16.9
2	11060.00	40.9 AV	54.0	-13.1	2.59 V	224	24.0	16.9
3	#16590.00	49.6 PK	68.2	-18.6	1.26 V	52	29.2	20.4

Remarks:

1. Emission Level(dBuV/m) = Raw Value(dBuV) + Correction Factor(dB/m)
2. Correction Factor(dB/m) = Antenna Factor(dB/m) + Cable Factor(dB) – Pre-Amplifier Factor(dB)
3. Margin value = Emission Level – Limit value
4. The other emission levels were very low against the limit.
5. "#": The radiated frequency is out of the restricted band.

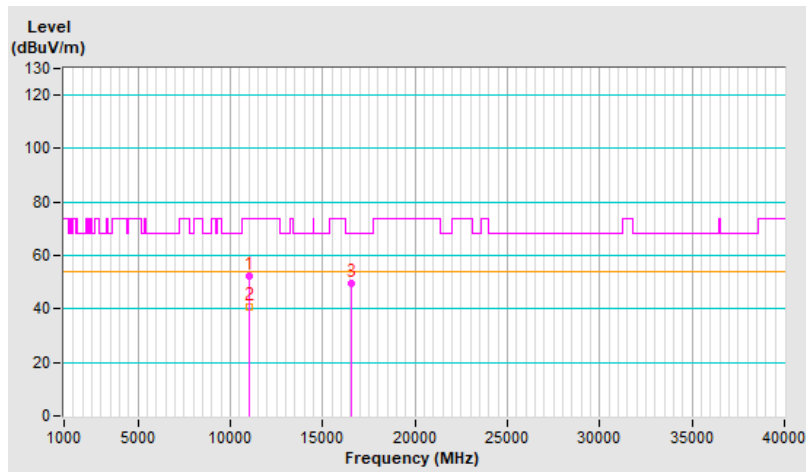

RF Mode	802.11be (EHT80)	Channel	CH 122 : 5610 MHz
Frequency Range	1 GHz ~ 40 GHz	Detector Function & Bandwidth	PK: RB=1 MHz, VB=3 MHz, DET=Peak AV: RB=1 MHz, VB=1 kHz, DET=Peak
Input Power (System)	120 Vac, 60 Hz	Environmental Conditions	24.0 °C, 68.0 % RH
Tested By	Sampson Chen		

Antenna Polarity & Test Distance : Horizontal at 3 m								
No	Frequency (MHz)	Emission Level (dBuV/m)	Limit (dBuV/m)	Margin (dB)	Antenna Height (m)	Table Angle (Degree)	Raw Value (dBuV)	Correction Factor (dB/m)
1	11220.00	49.0 PK	74.0	-25.0	3.72 H	80	32.3	16.7
2	11220.00	37.6 AV	54.0	-16.4	3.72 H	80	20.9	16.7
3	#16830.00	51.4 PK	68.2	-16.8	1.56 H	78	30.2	21.2

Remarks:

1. Emission Level(dBuV/m) = Raw Value(dBuV) + Correction Factor(dB/m)
2. Correction Factor(dB/m) = Antenna Factor(dB/m) + Cable Factor(dB) – Pre-Amplifier Factor(dB)
3. Margin value = Emission Level – Limit value
4. The other emission levels were very low against the limit.
5. " # " : The radiated frequency is out of the restricted band.

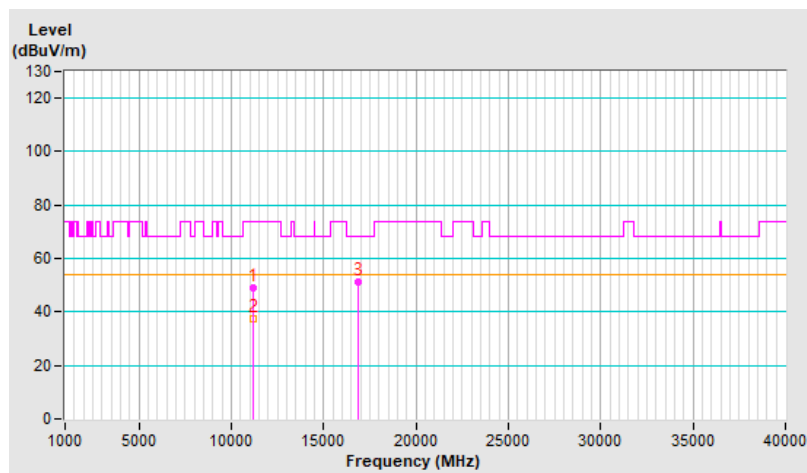

RF Mode	802.11be (EHT80)	Channel	CH 122 : 5610 MHz
Frequency Range	1 GHz ~ 40 GHz	Detector Function & Bandwidth	PK: RB=1 MHz, VB=3 MHz, DET=Peak AV: RB=1 MHz, VB=1 kHz, DET=Peak
Input Power (System)	120 Vac, 60 Hz	Environmental Conditions	24.0 °C, 68.0 % RH
Tested By	Sampson Chen		

Antenna Polarity & Test Distance : Vertical at 3 m								
No	Frequency (MHz)	Emission Level (dBuV/m)	Limit (dBuV/m)	Margin (dB)	Antenna Height (m)	Table Angle (Degree)	Raw Value (dBuV)	Correction Factor (dB/m)
1	11220.00	50.3 PK	74.0	-23.7	2.53 V	226	33.6	16.7
2	11220.00	41.4 AV	54.0	-12.6	2.53 V	226	24.7	16.7
3	#16830.00	50.3 PK	68.2	-17.9	1.24 V	48	29.1	21.2

Remarks:

1. Emission Level(dBuV/m) = Raw Value(dBuV) + Correction Factor(dB/m)
2. Correction Factor(dB/m) = Antenna Factor(dB/m) + Cable Factor(dB) – Pre-Amplifier Factor(dB)
3. Margin value = Emission Level – Limit value
4. The other emission levels were very low against the limit.
5. " # " : The radiated frequency is out of the restricted band.

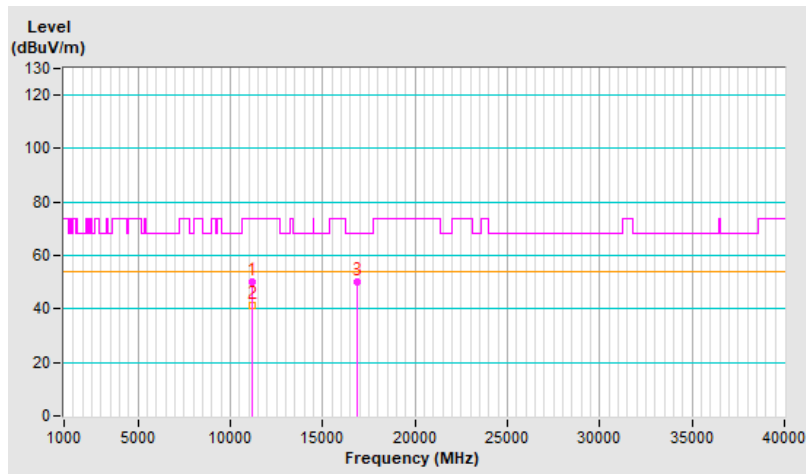

RF Mode	802.11be (EHT80)	Channel	CH 138 : 5690 MHz
Frequency Range	1 GHz ~ 40 GHz	Detector Function & Bandwidth	PK: RB=1 MHz, VB=3 MHz, DET=Peak AV: RB=1 MHz, VB=1 kHz, DET=Peak
Input Power (System)	120 Vac, 60 Hz	Environmental Conditions	24.0 °C, 68.0 % RH
Tested By	Sampson Chen		

Antenna Polarity & Test Distance : Horizontal at 3 m								
No	Frequency (MHz)	Emission Level (dBuV/m)	Limit (dBuV/m)	Margin (dB)	Antenna Height (m)	Table Angle (Degree)	Raw Value (dBuV)	Correction Factor (dB/m)
1	11380.00	48.5 PK	74.0	-25.5	3.63 H	71	31.5	17.0
2	11380.00	37.3 AV	54.0	-16.7	3.63 H	71	20.3	17.0
3	#17070.00	51.1 PK	68.2	-17.1	1.55 H	89	30.7	20.4

Remarks:

1. Emission Level(dBuV/m) = Raw Value(dBuV) + Correction Factor(dB/m)
2. Correction Factor(dB/m) = Antenna Factor(dB/m) + Cable Factor(dB) – Pre-Amplifier Factor(dB)
3. Margin value = Emission Level – Limit value
4. The other emission levels were very low against the limit.
5. " # " : The radiated frequency is out of the restricted band.

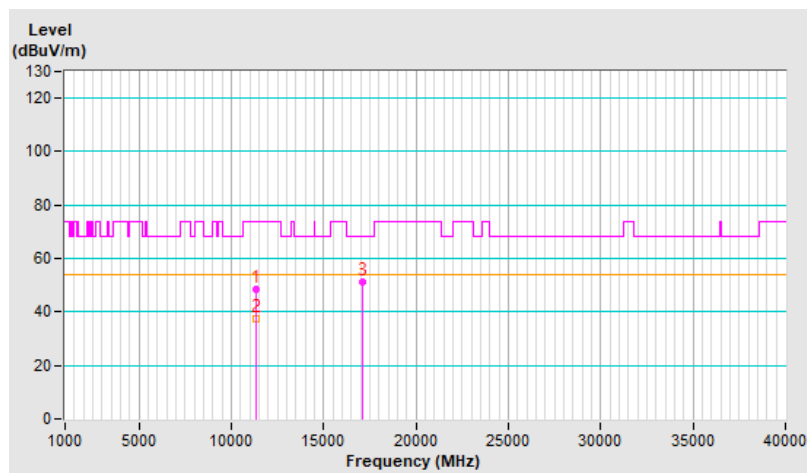

RF Mode	802.11be (EHT80)	Channel	CH 138 : 5690 MHz
Frequency Range	1 GHz ~ 40 GHz	Detector Function & Bandwidth	PK: RB=1 MHz, VB=3 MHz, DET=Peak AV: RB=1 MHz, VB=1 kHz, DET=Peak
Input Power (System)	120 Vac, 60 Hz	Environmental Conditions	24.0 °C, 68.0 % RH
Tested By	Sampson Chen		

Antenna Polarity & Test Distance : Vertical at 3 m								
No	Frequency (MHz)	Emission Level (dBuV/m)	Limit (dBuV/m)	Margin (dB)	Antenna Height (m)	Table Angle (Degree)	Raw Value (dBuV)	Correction Factor (dB/m)
1	11380.00	51.0 PK	74.0	-23.0	2.61 V	243	34.0	17.0
2	11380.00	43.2 AV	54.0	-10.8	2.61 V	243	26.2	17.0
3	#17070.00	50.9 PK	68.2	-17.3	1.24 V	48	30.5	20.4

Remarks:

1. Emission Level(dBuV/m) = Raw Value(dBuV) + Correction Factor(dB/m)
2. Correction Factor(dB/m) = Antenna Factor(dB/m) + Cable Factor(dB) – Pre-Amplifier Factor(dB)
3. Margin value = Emission Level – Limit value
4. The other emission levels were very low against the limit.
5. "#": The radiated frequency is out of the restricted band.

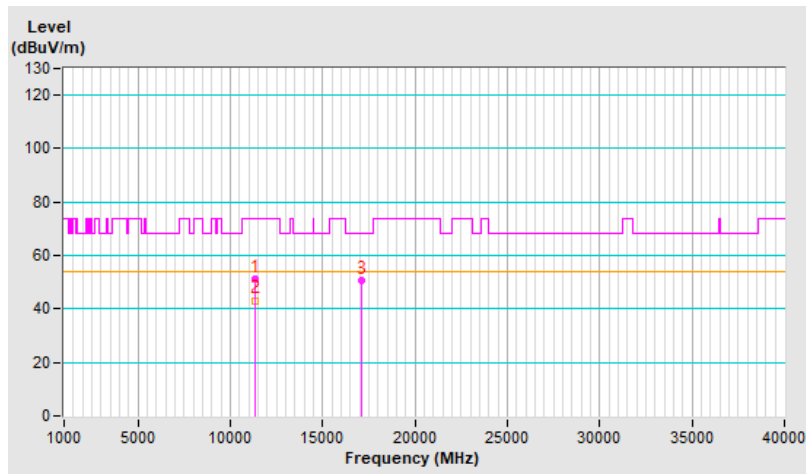

2S2T

RF Mode	802.11be (EHT20)	Channel	CH 149 : 5745 MHz
Frequency Range	1 GHz ~ 40 GHz	Detector Function & Bandwidth	PK: RB=1 MHz, VB=3 MHz, DET=Peak AV: RB=1 MHz, VB=510 Hz, DET=Peak
Input Power (System)	120 Vac, 60 Hz	Environmental Conditions	23.0 °C, 71.0 % RH
Tested By	Sampson Chen		

Antenna Polarity & Test Distance : Horizontal at 3 m								
No	Frequency (MHz)	Emission Level (dBuV/m)	Limit (dBuV/m)	Margin (dB)	Antenna Height (m)	Table Angle (Degree)	Raw Value (dBuV)	Correction Factor (dB/m)
1	11490.00	48.4 PK	74.0	-25.6	3.66 H	70	31.5	16.9
2	11490.00	37.1 AV	54.0	-16.9	3.66 H	70	20.2	16.9
3	#17235.00	49.2 PK	68.2	-19.0	1.57 H	77	29.1	20.1

Remarks:

1. Emission Level(dBuV/m) = Raw Value(dBuV) + Correction Factor(dB/m)
2. Correction Factor(dB/m) = Antenna Factor(dB/m) + Cable Factor(dB) – Pre-Amplifier Factor(dB)
3. Margin value = Emission Level – Limit value
4. The other emission levels were very low against the limit.
5. "#": The radiated frequency is out of the restricted band.

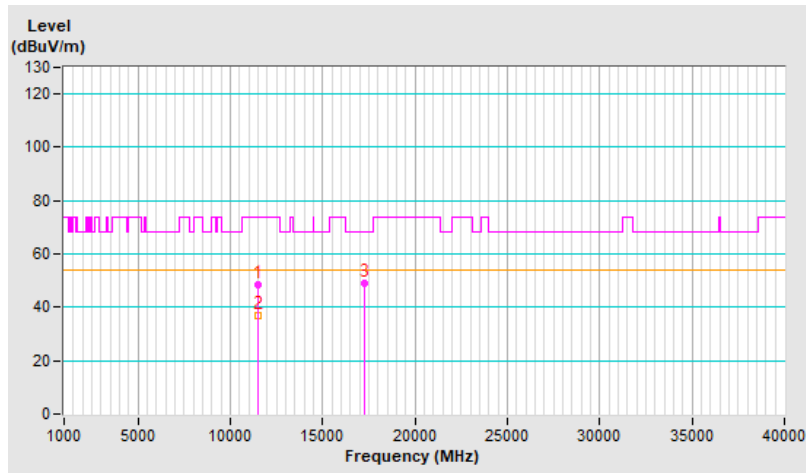

RF Mode	802.11be (EHT20)	Channel	CH 149 : 5745 MHz
Frequency Range	1 GHz ~ 40 GHz	Detector Function & Bandwidth	PK: RB=1 MHz, VB=3 MHz, DET=Peak AV: RB=1 MHz, VB=510 Hz, DET=Peak
Input Power (System)	120 Vac, 60 Hz	Environmental Conditions	23.0 °C, 71.0 % RH
Tested By	Sampson Chen		

Antenna Polarity & Test Distance : Vertical at 3 m								
No	Frequency (MHz)	Emission Level (dBuV/m)	Limit (dBuV/m)	Margin (dB)	Antenna Height (m)	Table Angle (Degree)	Raw Value (dBuV)	Correction Factor (dB/m)
1	11490.00	49.9 PK	74.0	-24.1	2.54 V	222	33.0	16.9
2	11490.00	40.8 AV	54.0	-13.2	2.54 V	222	23.9	16.9
3	#17235.00	49.6 PK	68.2	-18.6	1.28 V	66	29.5	20.1

Remarks:

1. Emission Level(dBuV/m) = Raw Value(dBuV) + Correction Factor(dB/m)
2. Correction Factor(dB/m) = Antenna Factor(dB/m) + Cable Factor(dB) – Pre-Amplifier Factor(dB)
3. Margin value = Emission Level – Limit value
4. The other emission levels were very low against the limit.
5. "#": The radiated frequency is out of the restricted band.

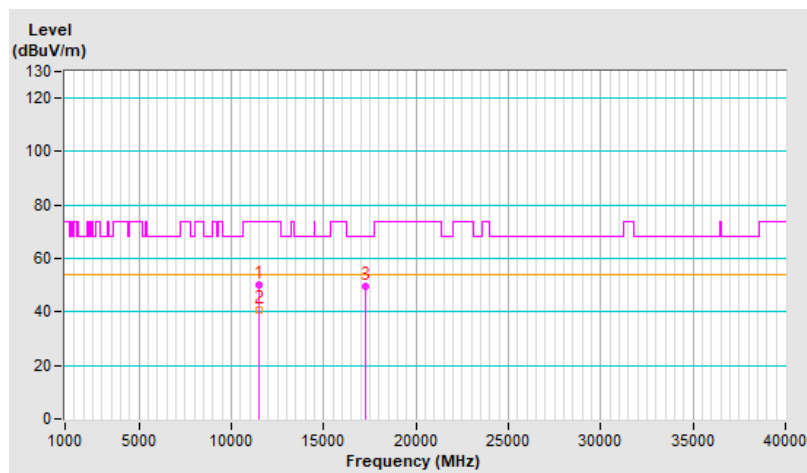

RF Mode	802.11be (EHT20)	Channel	CH 157 : 5785 MHz
Frequency Range	1 GHz ~ 40 GHz	Detector Function & Bandwidth	PK: RB=1 MHz, VB=3 MHz, DET=Peak AV: RB=1 MHz, VB=510 Hz, DET=Peak
Input Power (System)	120 Vac, 60 Hz	Environmental Conditions	23.0 °C, 71.0 % RH
Tested By	Sampson Chen		

Antenna Polarity & Test Distance : Horizontal at 3 m								
No	Frequency (MHz)	Emission Level (dBuV/m)	Limit (dBuV/m)	Margin (dB)	Antenna Height (m)	Table Angle (Degree)	Raw Value (dBuV)	Correction Factor (dB/m)
1	11570.00	48.2 PK	74.0	-25.8	3.70 H	77	31.2	17.0
2	11570.00	37.1 AV	54.0	-16.9	3.70 H	77	20.1	17.0
3	#17355.00	49.1 PK	68.2	-19.1	1.55 H	89	28.0	21.1

Remarks:

1. Emission Level(dBuV/m) = Raw Value(dBuV) + Correction Factor(dB/m)
2. Correction Factor(dB/m) = Antenna Factor(dB/m) + Cable Factor(dB) – Pre-Amplifier Factor(dB)
3. Margin value = Emission Level – Limit value
4. The other emission levels were very low against the limit.
5. " # " : The radiated frequency is out of the restricted band.

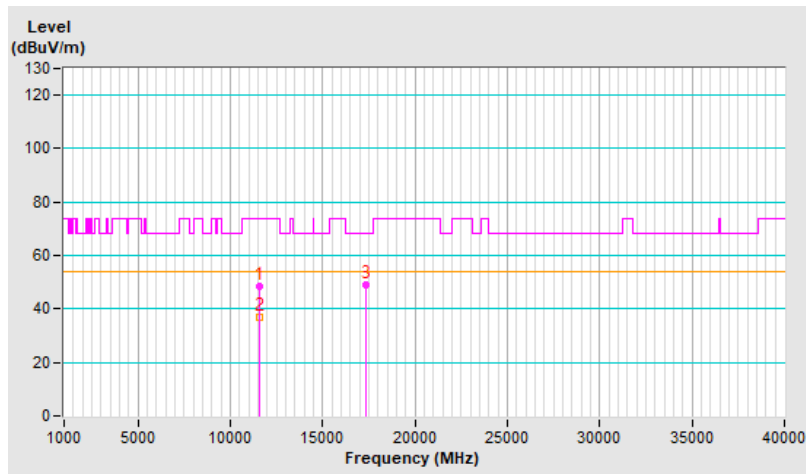

RF Mode	802.11be (EHT20)	Channel	CH 157 : 5785 MHz
Frequency Range	1 GHz ~ 40 GHz	Detector Function & Bandwidth	PK: RB=1 MHz, VB=3 MHz, DET=Peak AV: RB=1 MHz, VB=510 Hz, DET=Peak
Input Power (System)	120 Vac, 60 Hz	Environmental Conditions	23.0 °C, 71.0 % RH
Tested By	Sampson Chen		

Antenna Polarity & Test Distance : Vertical at 3 m								
No	Frequency (MHz)	Emission Level (dBuV/m)	Limit (dBuV/m)	Margin (dB)	Antenna Height (m)	Table Angle (Degree)	Raw Value (dBuV)	Correction Factor (dB/m)
1	11570.00	49.9 PK	74.0	-24.1	2.61 V	229	32.9	17.0
2	11570.00	40.3 AV	54.0	-13.7	2.61 V	229	23.3	17.0
3	#17355.00	50.1 PK	68.2	-18.1	1.29 V	43	29.0	21.1

Remarks:

1. Emission Level(dBuV/m) = Raw Value(dBuV) + Correction Factor(dB/m)
2. Correction Factor(dB/m) = Antenna Factor(dB/m) + Cable Factor(dB) – Pre-Amplifier Factor(dB)
3. Margin value = Emission Level – Limit value
4. The other emission levels were very low against the limit.
5. "#": The radiated frequency is out of the restricted band.

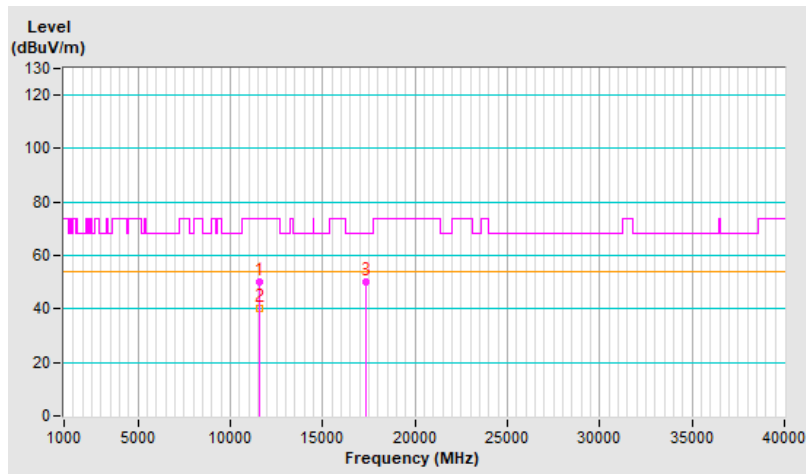

RF Mode	802.11be (EHT20)	Channel	CH 165 : 5825 MHz
Frequency Range	1 GHz ~ 40 GHz	Detector Function & Bandwidth	PK: RB=1 MHz, VB=3 MHz, DET=Peak AV: RB=1 MHz, VB=510 Hz, DET=Peak
Input Power (System)	120 Vac, 60 Hz	Environmental Conditions	23.0 °C, 71.0 % RH
Tested By	Sampson Chen		

Antenna Polarity & Test Distance : Horizontal at 3 m								
No	Frequency (MHz)	Emission Level (dBuV/m)	Limit (dBuV/m)	Margin (dB)	Antenna Height (m)	Table Angle (Degree)	Raw Value (dBuV)	Correction Factor (dB/m)
1	11650.00	47.9 PK	74.0	-26.1	3.62 H	77	31.0	16.9
2	11650.00	37.0 AV	54.0	-17.0	3.62 H	77	20.1	16.9
3	#17475.00	48.5 PK	68.2	-19.7	1.56 H	92	26.1	22.4

Remarks:

1. Emission Level(dBuV/m) = Raw Value(dBuV) + Correction Factor(dB/m)
2. Correction Factor(dB/m) = Antenna Factor(dB/m) + Cable Factor(dB) – Pre-Amplifier Factor(dB)
3. Margin value = Emission Level – Limit value
4. The other emission levels were very low against the limit.
5. "#": The radiated frequency is out of the restricted band.

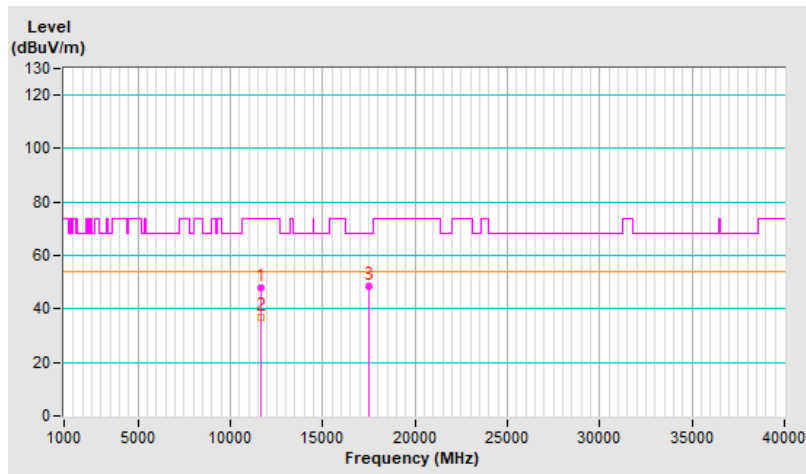

RF Mode	802.11be (EHT20)	Channel	CH 165 : 5825 MHz
Frequency Range	1 GHz ~ 40 GHz	Detector Function & Bandwidth	PK: RB=1 MHz, VB=3 MHz, DET=Peak AV: RB=1 MHz, VB=510 Hz, DET=Peak
Input Power (System)	120 Vac, 60 Hz	Environmental Conditions	23.0 °C, 71.0 % RH
Tested By	Sampson Chen		

Antenna Polarity & Test Distance : Vertical at 3 m								
No	Frequency (MHz)	Emission Level (dBuV/m)	Limit (dBuV/m)	Margin (dB)	Antenna Height (m)	Table Angle (Degree)	Raw Value (dBuV)	Correction Factor (dB/m)
1	11650.00	50.2 PK	74.0	-23.8	2.56 V	219	33.3	16.9
2	11650.00	40.5 AV	54.0	-13.5	2.56 V	219	23.6	16.9
3	#17475.00	49.4 PK	68.2	-18.8	1.28 V	65	27.0	22.4

Remarks:

1. Emission Level(dBuV/m) = Raw Value(dBuV) + Correction Factor(dB/m)
2. Correction Factor(dB/m) = Antenna Factor(dB/m) + Cable Factor(dB) – Pre-Amplifier Factor(dB)
3. Margin value = Emission Level – Limit value
4. The other emission levels were very low against the limit.
5. "#": The radiated frequency is out of the restricted band.

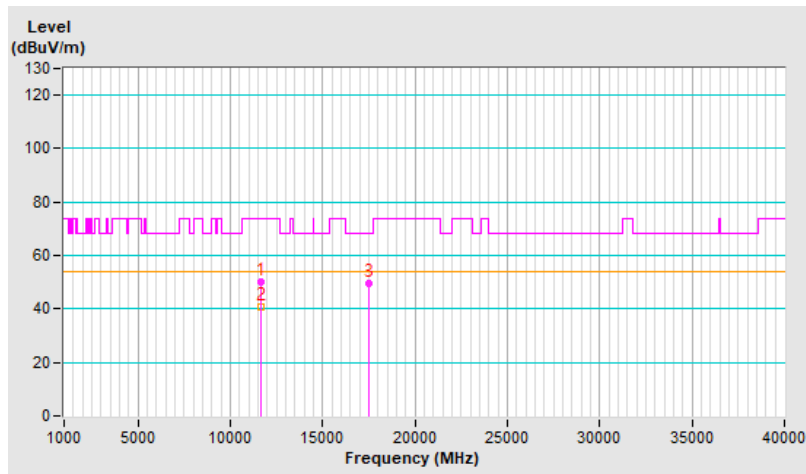

RF Mode	802.11be (EHT40)	Channel	CH 38 : 5190 MHz
Frequency Range	1 GHz ~ 40 GHz	Detector Function & Bandwidth	PK: RB=1 MHz, VB=3 MHz, DET=Peak AV: RB=1 MHz, VB=510 Hz, DET=Peak
Input Power (System)	120 Vac, 60 Hz	Environmental Conditions	23.0 °C, 71.0 % RH
Tested By	Sampson Chen		

Antenna Polarity & Test Distance : Horizontal at 3 m								
No	Frequency (MHz)	Emission Level (dBuV/m)	Limit (dBuV/m)	Margin (dB)	Antenna Height (m)	Table Angle (Degree)	Raw Value (dBuV)	Correction Factor (dB/m)
1	#10380.00	48.3 PK	68.2	-19.9	3.66 H	71	32.3	16.0
2	15570.00	50.1 PK	74.0	-23.9	1.63 H	84	33.2	16.9
3	15570.00	41.5 AV	54.0	-12.5	1.63 H	84	24.6	16.9

Remarks:

1. Emission Level(dBuV/m) = Raw Value(dBuV) + Correction Factor(dB/m)
2. Correction Factor(dB/m) = Antenna Factor(dB/m) + Cable Factor(dB) – Pre-Amplifier Factor(dB)
3. Margin value = Emission Level – Limit value
4. The other emission levels were very low against the limit.
5. "# # ": The radiated frequency is out of the restricted band.

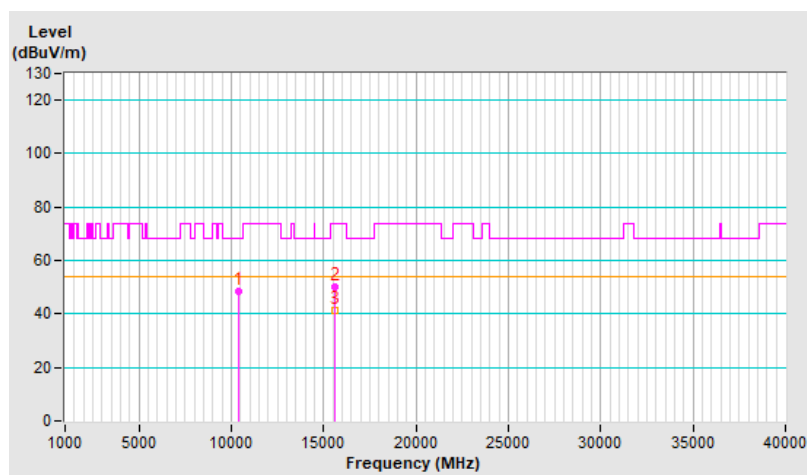

RF Mode	802.11be (EHT40)	Channel	CH 38 : 5190 MHz
Frequency Range	1 GHz ~ 40 GHz	Detector Function & Bandwidth	PK: RB=1 MHz, VB=3 MHz, DET=Peak AV: RB=1 MHz, VB=510 Hz, DET=Peak
Input Power (System)	120 Vac, 60 Hz	Environmental Conditions	23.0 °C, 71.0 % RH
Tested By	Sampson Chen		

Antenna Polarity & Test Distance : Vertical at 3 m								
No	Frequency (MHz)	Emission Level (dBuV/m)	Limit (dBuV/m)	Margin (dB)	Antenna Height (m)	Table Angle (Degree)	Raw Value (dBuV)	Correction Factor (dB/m)
1	#10380.00	50.0 PK	68.2	-18.2	2.62 V	236	34.0	16.0
2	15570.00	49.1 PK	74.0	-24.9	1.24 V	41	32.2	16.9
3	15570.00	39.7 AV	54.0	-14.3	1.24 V	41	22.8	16.9

Remarks:

1. Emission Level(dBuV/m) = Raw Value(dBuV) + Correction Factor(dB/m)
2. Correction Factor(dB/m) = Antenna Factor(dB/m) + Cable Factor(dB) – Pre-Amplifier Factor(dB)
3. Margin value = Emission Level – Limit value
4. The other emission levels were very low against the limit.
5. " # " : The radiated frequency is out of the restricted band.

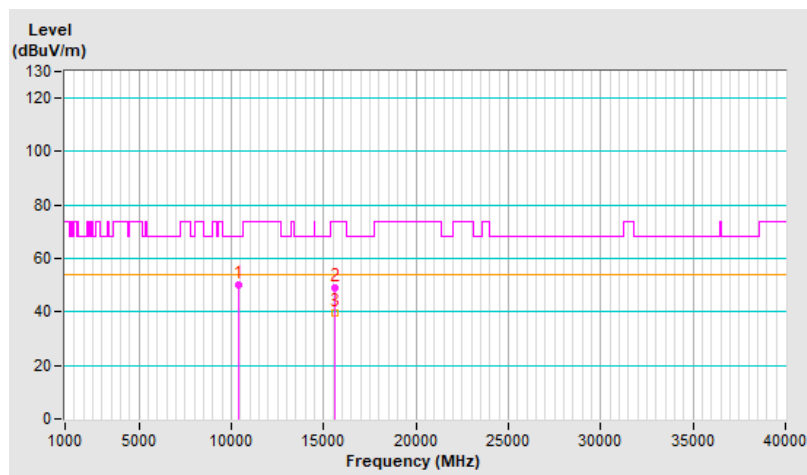

RF Mode	802.11be (EHT40)	Channel	CH 46 : 5230 MHz
Frequency Range	1 GHz ~ 40 GHz	Detector Function & Bandwidth	PK: RB=1 MHz, VB=3 MHz, DET=Peak AV: RB=1 MHz, VB=510 Hz, DET=Peak
Input Power (System)	120 Vac, 60 Hz	Environmental Conditions	23.0 °C, 71.0 % RH
Tested By	Sampson Chen		

Antenna Polarity & Test Distance : Horizontal at 3 m								
No	Frequency (MHz)	Emission Level (dBuV/m)	Limit (dBuV/m)	Margin (dB)	Antenna Height (m)	Table Angle (Degree)	Raw Value (dBuV)	Correction Factor (dB/m)
1	#10460.00	47.7 PK	68.2	-20.5	3.66 H	90	31.7	16.0
2	15690.00	49.3 PK	74.0	-24.7	1.63 H	88	32.1	17.2
3	15690.00	41.2 AV	54.0	-12.8	1.63 H	88	24.0	17.2

Remarks:

1. Emission Level(dBuV/m) = Raw Value(dBuV) + Correction Factor(dB/m)
2. Correction Factor(dB/m) = Antenna Factor(dB/m) + Cable Factor(dB) – Pre-Amplifier Factor(dB)
3. Margin value = Emission Level – Limit value
4. The other emission levels were very low against the limit.
5. " # " : The radiated frequency is out of the restricted band.

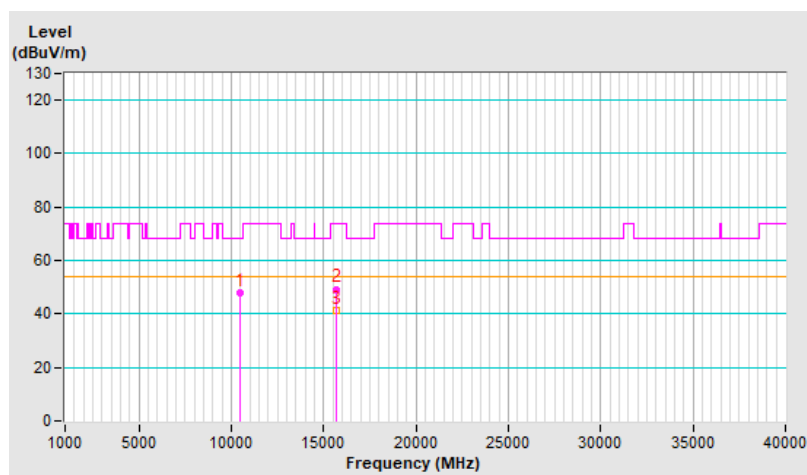

RF Mode	802.11be (EHT40)	Channel	CH 46 : 5230 MHz
Frequency Range	1 GHz ~ 40 GHz	Detector Function & Bandwidth	PK: RB=1 MHz, VB=3 MHz, DET=Peak AV: RB=1 MHz, VB=510 Hz, DET=Peak
Input Power (System)	120 Vac, 60 Hz	Environmental Conditions	23.0 °C, 71.0 % RH
Tested By	Sampson Chen		

Antenna Polarity & Test Distance : Vertical at 3 m								
No	Frequency (MHz)	Emission Level (dBuV/m)	Limit (dBuV/m)	Margin (dB)	Antenna Height (m)	Table Angle (Degree)	Raw Value (dBuV)	Correction Factor (dB/m)
1	#10460.00	50.2 PK	68.2	-18.0	2.57 V	245	34.2	16.0
2	15690.00	49.7 PK	74.0	-24.3	1.31 V	40	32.5	17.2
3	15690.00	40.0 AV	54.0	-14.0	1.31 V	40	22.8	17.2

Remarks:

1. Emission Level(dBuV/m) = Raw Value(dBuV) + Correction Factor(dB/m)
2. Correction Factor(dB/m) = Antenna Factor(dB/m) + Cable Factor(dB) – Pre-Amplifier Factor(dB)
3. Margin value = Emission Level – Limit value
4. The other emission levels were very low against the limit.
5. " # " : The radiated frequency is out of the restricted band.

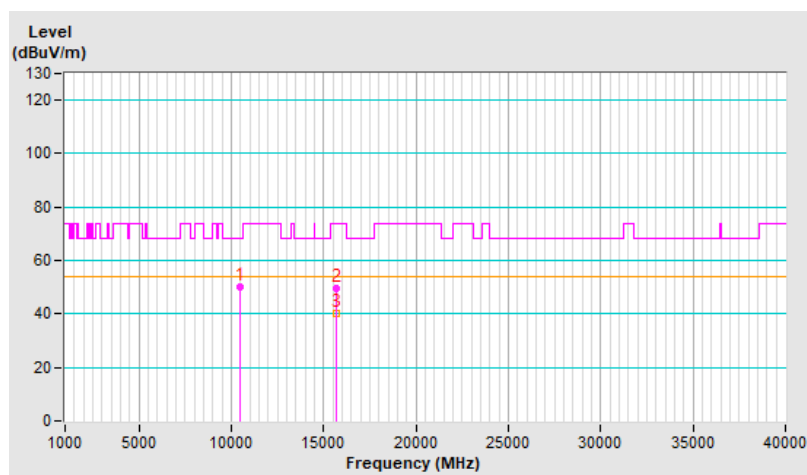

RF Mode	802.11be (EHT40)	Channel	CH 54 : 5270 MHz
Frequency Range	1 GHz ~ 40 GHz	Detector Function & Bandwidth	PK: RB=1 MHz, VB=3 MHz, DET=Peak AV: RB=1 MHz, VB=510 Hz, DET=Peak
Input Power (System)	120 Vac, 60 Hz	Environmental Conditions	23.0 °C, 71.0 % RH
Tested By	Sampson Chen		

Antenna Polarity & Test Distance : Horizontal at 3 m								
No	Frequency (MHz)	Emission Level (dBuV/m)	Limit (dBuV/m)	Margin (dB)	Antenna Height (m)	Table Angle (Degree)	Raw Value (dBuV)	Correction Factor (dB/m)
1	#10540.00	48.9 PK	68.2	-19.3	3.66 H	76	32.8	16.1
2	15810.00	49.1 PK	74.0	-24.9	1.54 H	81	32.0	17.1
3	15810.00	40.9 AV	54.0	-13.1	1.54 H	81	23.8	17.1

Remarks:

1. Emission Level(dBuV/m) = Raw Value(dBuV) + Correction Factor(dB/m)
2. Correction Factor(dB/m) = Antenna Factor(dB/m) + Cable Factor(dB) – Pre-Amplifier Factor(dB)
3. Margin value = Emission Level – Limit value
4. The other emission levels were very low against the limit.
5. "#": The radiated frequency is out of the restricted band.

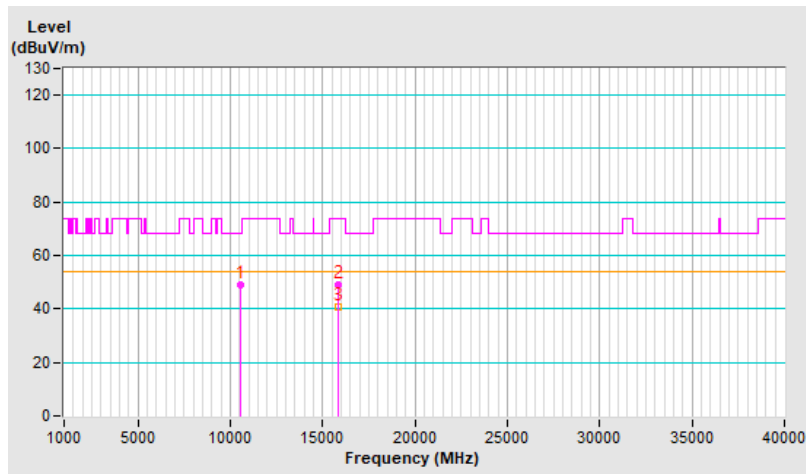

RF Mode	802.11be (EHT40)	Channel	CH 54 : 5270 MHz
Frequency Range	1 GHz ~ 40 GHz	Detector Function & Bandwidth	PK: RB=1 MHz, VB=3 MHz, DET=Peak AV: RB=1 MHz, VB=510 Hz, DET=Peak
Input Power (System)	120 Vac, 60 Hz	Environmental Conditions	23.0 °C, 71.0 % RH
Tested By	Sampson Chen		

Antenna Polarity & Test Distance : Vertical at 3 m								
No	Frequency (MHz)	Emission Level (dBuV/m)	Limit (dBuV/m)	Margin (dB)	Antenna Height (m)	Table Angle (Degree)	Raw Value (dBuV)	Correction Factor (dB/m)
1	#10540.00	49.3 PK	68.2	-18.9	2.62 V	247	33.2	16.1
2	15810.00	49.3 PK	74.0	-24.7	1.27 V	57	32.2	17.1
3	15810.00	40.0 AV	54.0	-14.0	1.27 V	57	22.9	17.1

Remarks:

1. Emission Level(dBuV/m) = Raw Value(dBuV) + Correction Factor(dB/m)
2. Correction Factor(dB/m) = Antenna Factor(dB/m) + Cable Factor(dB) – Pre-Amplifier Factor(dB)
3. Margin value = Emission Level – Limit value
4. The other emission levels were very low against the limit.
5. " # " : The radiated frequency is out of the restricted band.

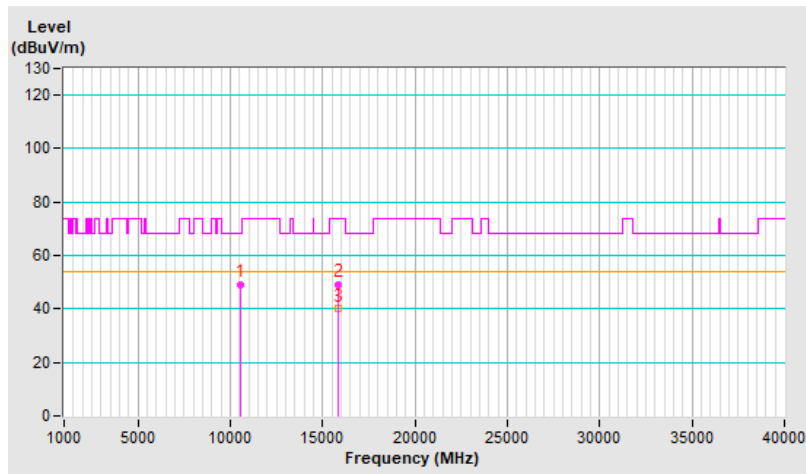

RF Mode	802.11be (EHT40)	Channel	CH 62 : 5310 MHz
Frequency Range	1 GHz ~ 40 GHz	Detector Function & Bandwidth	PK: RB=1 MHz, VB=3 MHz, DET=Peak AV: RB=1 MHz, VB=510 Hz, DET=Peak
Input Power (System)	120 Vac, 60 Hz	Environmental Conditions	23.0 °C, 71.0 % RH
Tested By	Sampson Chen		

Antenna Polarity & Test Distance : Horizontal at 3 m								
No	Frequency (MHz)	Emission Level (dBuV/m)	Limit (dBuV/m)	Margin (dB)	Antenna Height (m)	Table Angle (Degree)	Raw Value (dBuV)	Correction Factor (dB/m)
1	10620.00	48.9 PK	74.0	-25.1	3.71 H	73	32.5	16.4
2	10620.00	37.7 AV	54.0	-16.3	3.71 H	73	21.3	16.4
3	15930.00	48.8 PK	74.0	-25.2	1.57 H	77	31.5	17.3
4	15930.00	40.5 AV	54.0	-13.5	1.57 H	77	23.2	17.3

Remarks:

1. Emission Level(dBuV/m) = Raw Value(dBuV) + Correction Factor(dB/m)
2. Correction Factor(dB/m) = Antenna Factor(dB/m) + Cable Factor(dB) – Pre-Amplifier Factor(dB)
3. Margin value = Emission Level – Limit value
4. The other emission levels were very low against the limit.

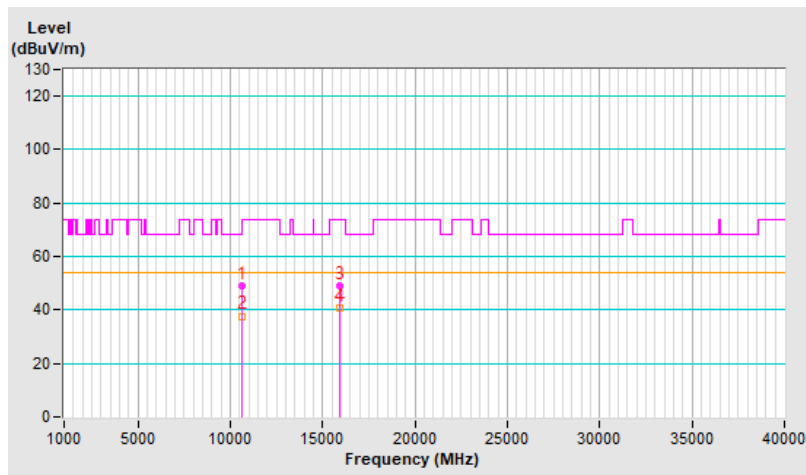

RF Mode	802.11be (EHT40)	Channel	CH 62 : 5310 MHz
Frequency Range	1 GHz ~ 40 GHz	Detector Function & Bandwidth	PK: RB=1 MHz, VB=3 MHz, DET=Peak AV: RB=1 MHz, VB=510 Hz, DET=Peak
Input Power (System)	120 Vac, 60 Hz	Environmental Conditions	23.0 °C, 71.0 % RH
Tested By	Sampson Chen		

Antenna Polarity & Test Distance : Vertical at 3 m								
No	Frequency (MHz)	Emission Level (dBuV/m)	Limit (dBuV/m)	Margin (dB)	Antenna Height (m)	Table Angle (Degree)	Raw Value (dBuV)	Correction Factor (dB/m)
1	10620.00	49.7 PK	74.0	-24.3	2.65 V	249	33.3	16.4
2	10620.00	40.4 AV	54.0	-13.6	2.65 V	249	24.0	16.4
3	15930.00	49.1 PK	74.0	-24.9	1.24 V	67	31.8	17.3
4	15930.00	39.8 AV	54.0	-14.2	1.24 V	67	22.5	17.3

Remarks:

1. Emission Level(dBuV/m) = Raw Value(dBuV) + Correction Factor(dB/m)
2. Correction Factor(dB/m) = Antenna Factor(dB/m) + Cable Factor(dB) – Pre-Amplifier Factor(dB)
3. Margin value = Emission Level – Limit value
4. The other emission levels were very low against the limit.

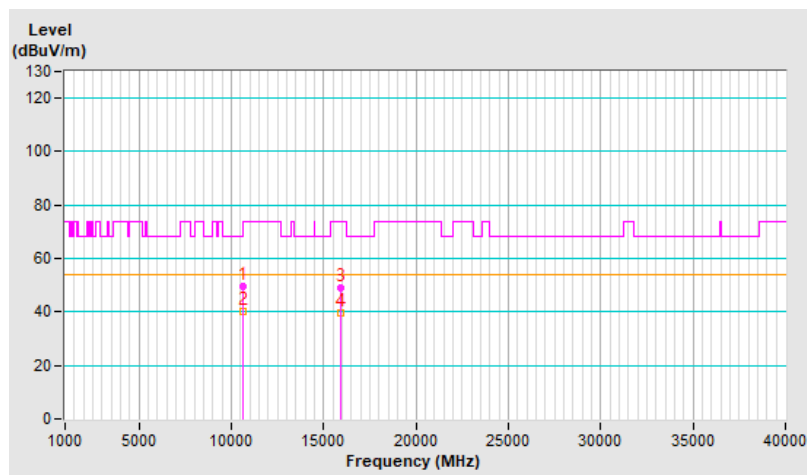

RF Mode	802.11be (EHT80)	Channel	CH 106 : 5530 MHz
Frequency Range	1 GHz ~ 40 GHz	Detector Function & Bandwidth	PK: RB=1 MHz, VB=3 MHz, DET=Peak AV: RB=1 MHz, VB=1 kHz, DET=Peak
Input Power (System)	120 Vac, 60 Hz	Environmental Conditions	23.0 °C, 71.0 % RH
Tested By	Sampson Chen		

Antenna Polarity & Test Distance : Horizontal at 3 m								
No	Frequency (MHz)	Emission Level (dBuV/m)	Limit (dBuV/m)	Margin (dB)	Antenna Height (m)	Table Angle (Degree)	Raw Value (dBuV)	Correction Factor (dB/m)
1	11060.00	47.9 PK	74.0	-26.1	3.69 H	85	31.0	16.9
2	11060.00	37.0 AV	54.0	-17.0	3.69 H	85	20.1	16.9
3	#16590.00	50.0 PK	68.2	-18.2	1.60 H	92	29.6	20.4

Remarks:

1. Emission Level(dBuV/m) = Raw Value(dBuV) + Correction Factor(dB/m)
2. Correction Factor(dB/m) = Antenna Factor(dB/m) + Cable Factor(dB) – Pre-Amplifier Factor(dB)
3. Margin value = Emission Level – Limit value
4. The other emission levels were very low against the limit.
5. " # " : The radiated frequency is out of the restricted band.

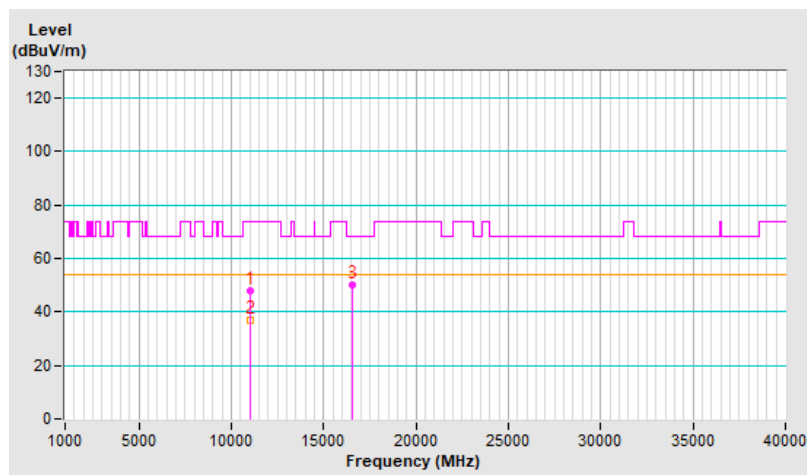

RF Mode	802.11be (EHT80)	Channel	CH 106 : 5530 MHz
Frequency Range	1 GHz ~ 40 GHz	Detector Function & Bandwidth	PK: RB=1 MHz, VB=3 MHz, DET=Peak AV: RB=1 MHz, VB=1 kHz, DET=Peak
Input Power (System)	120 Vac, 60 Hz	Environmental Conditions	23.0 °C, 71.0 % RH
Tested By	Sampson Chen		

Antenna Polarity & Test Distance : Vertical at 3 m								
No	Frequency (MHz)	Emission Level (dBuV/m)	Limit (dBuV/m)	Margin (dB)	Antenna Height (m)	Table Angle (Degree)	Raw Value (dBuV)	Correction Factor (dB/m)
1	11060.00	50.4 PK	74.0	-23.6	2.58 V	233	33.5	16.9
2	11060.00	41.0 AV	54.0	-13.0	2.58 V	233	24.1	16.9
3	#16590.00	49.8 PK	68.2	-18.4	1.26 V	55	29.4	20.4

Remarks:

1. Emission Level(dBuV/m) = Raw Value(dBuV) + Correction Factor(dB/m)
2. Correction Factor(dB/m) = Antenna Factor(dB/m) + Cable Factor(dB) – Pre-Amplifier Factor(dB)
3. Margin value = Emission Level – Limit value
4. The other emission levels were very low against the limit.
5. " # " : The radiated frequency is out of the restricted band.

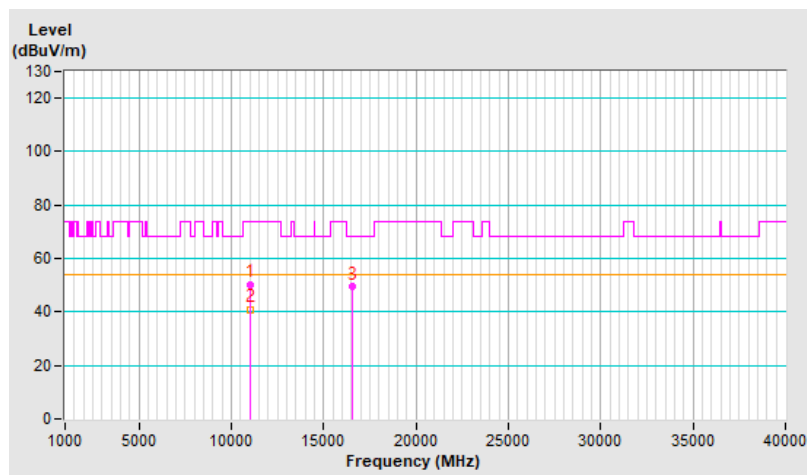

RF Mode	802.11be (EHT80)	Channel	CH 122 : 5610 MHz
Frequency Range	1 GHz ~ 40 GHz	Detector Function & Bandwidth	PK: RB=1 MHz, VB=3 MHz, DET=Peak AV: RB=1 MHz, VB=1 kHz, DET=Peak
Input Power (System)	120 Vac, 60 Hz	Environmental Conditions	23.0 °C, 71.0 % RH
Tested By	Sampson Chen		

Antenna Polarity & Test Distance : Horizontal at 3 m								
No	Frequency (MHz)	Emission Level (dBuV/m)	Limit (dBuV/m)	Margin (dB)	Antenna Height (m)	Table Angle (Degree)	Raw Value (dBuV)	Correction Factor (dB/m)
1	11220.00	48.8 PK	74.0	-25.2	3.68 H	76	32.1	16.7
2	11220.00	37.6 AV	54.0	-16.4	3.68 H	76	20.9	16.7
3	#16830.00	49.7 PK	68.2	-18.5	1.57 H	78	28.5	21.2

Remarks:

1. Emission Level(dBuV/m) = Raw Value(dBuV) + Correction Factor(dB/m)
2. Correction Factor(dB/m) = Antenna Factor(dB/m) + Cable Factor(dB) – Pre-Amplifier Factor(dB)
3. Margin value = Emission Level – Limit value
4. The other emission levels were very low against the limit.
5. "#": The radiated frequency is out of the restricted band.

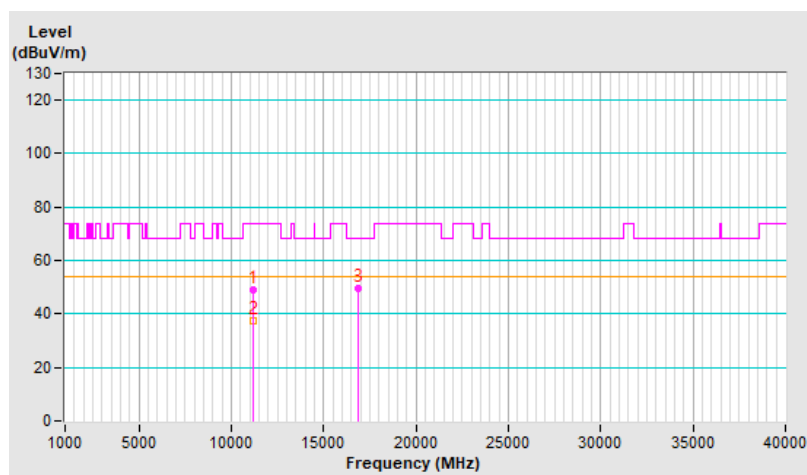

RF Mode	802.11be (EHT80)	Channel	CH 122 : 5610 MHz
Frequency Range	1 GHz ~ 40 GHz	Detector Function & Bandwidth	PK: RB=1 MHz, VB=3 MHz, DET=Peak AV: RB=1 MHz, VB=1 kHz, DET=Peak
Input Power (System)	120 Vac, 60 Hz	Environmental Conditions	23.0 °C, 71.0 % RH
Tested By	Sampson Chen		

Antenna Polarity & Test Distance : Vertical at 3 m								
No	Frequency (MHz)	Emission Level (dBuV/m)	Limit (dBuV/m)	Margin (dB)	Antenna Height (m)	Table Angle (Degree)	Raw Value (dBuV)	Correction Factor (dB/m)
1	11220.00	50.2 PK	74.0	-23.8	2.57 V	222	33.5	16.7
2	11220.00	40.9 AV	54.0	-13.1	2.57 V	222	24.2	16.7
3	#16830.00	49.6 PK	68.2	-18.6	1.34 V	66	28.4	21.2

Remarks:

1. Emission Level(dBuV/m) = Raw Value(dBuV) + Correction Factor(dB/m)
2. Correction Factor(dB/m) = Antenna Factor(dB/m) + Cable Factor(dB) – Pre-Amplifier Factor(dB)
3. Margin value = Emission Level – Limit value
4. The other emission levels were very low against the limit.
5. "#": The radiated frequency is out of the restricted band.

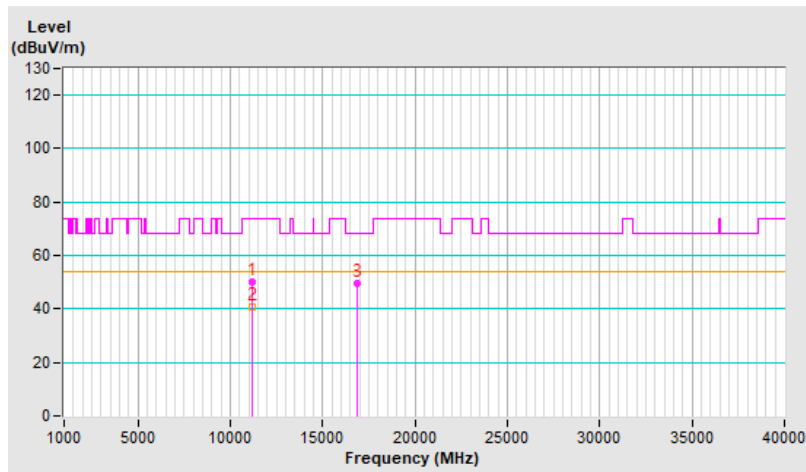

RF Mode	802.11be (EHT80)	Channel	CH 138 : 5690 MHz
Frequency Range	1 GHz ~ 40 GHz	Detector Function & Bandwidth	PK: RB=1 MHz, VB=3 MHz, DET=Peak AV: RB=1 MHz, VB=1 kHz, DET=Peak
Input Power (System)	120 Vac, 60 Hz	Environmental Conditions	23.0 °C, 71.0 % RH
Tested By	Sampson Chen		

Antenna Polarity & Test Distance : Horizontal at 3 m								
No	Frequency (MHz)	Emission Level (dBuV/m)	Limit (dBuV/m)	Margin (dB)	Antenna Height (m)	Table Angle (Degree)	Raw Value (dBuV)	Correction Factor (dB/m)
1	11380.00	48.0 PK	74.0	-26.0	3.62 H	87	31.0	17.0
2	11380.00	36.9 AV	54.0	-17.1	3.62 H	87	19.9	17.0
3	#17070.00	49.8 PK	68.2	-18.4	1.64 H	64	29.4	20.4

Remarks:

1. Emission Level(dBuV/m) = Raw Value(dBuV) + Correction Factor(dB/m)
2. Correction Factor(dB/m) = Antenna Factor(dB/m) + Cable Factor(dB) – Pre-Amplifier Factor(dB)
3. Margin value = Emission Level – Limit value
4. The other emission levels were very low against the limit.
5. "#": The radiated frequency is out of the restricted band.

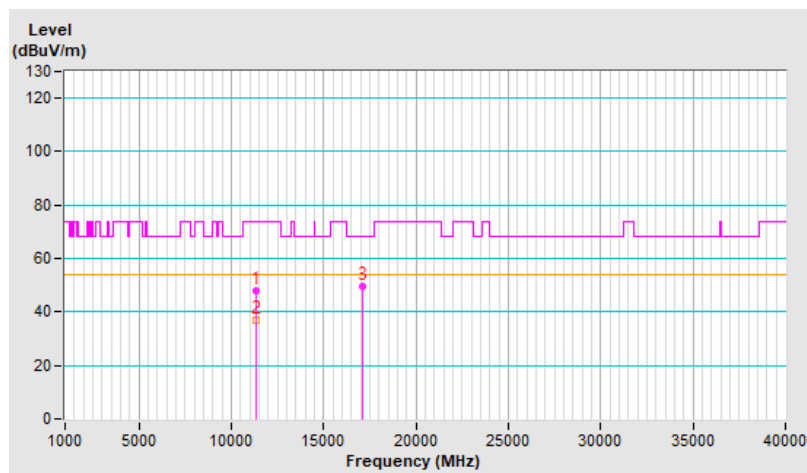

RF Mode	802.11be (EHT80)	Channel	CH 138 : 5690 MHz
Frequency Range	1 GHz ~ 40 GHz	Detector Function & Bandwidth	PK: RB=1 MHz, VB=3 MHz, DET=Peak AV: RB=1 MHz, VB=1 kHz, DET=Peak
Input Power (System)	120 Vac, 60 Hz	Environmental Conditions	23.0 °C, 71.0 % RH
Tested By	Sampson Chen		

Antenna Polarity & Test Distance : Vertical at 3 m								
No	Frequency (MHz)	Emission Level (dBuV/m)	Limit (dBuV/m)	Margin (dB)	Antenna Height (m)	Table Angle (Degree)	Raw Value (dBuV)	Correction Factor (dB/m)
1	11380.00	50.2 PK	74.0	-23.8	2.53 V	233	33.2	17.0
2	11380.00	40.9 AV	54.0	-13.1	2.53 V	233	23.9	17.0
3	#17070.00	49.3 PK	68.2	-18.9	1.29 V	59	28.9	20.4

Remarks:

1. Emission Level(dBuV/m) = Raw Value(dBuV) + Correction Factor(dB/m)
2. Correction Factor(dB/m) = Antenna Factor(dB/m) + Cable Factor(dB) – Pre-Amplifier Factor(dB)
3. Margin value = Emission Level – Limit value
4. The other emission levels were very low against the limit.
5. "#": The radiated frequency is out of the restricted band.

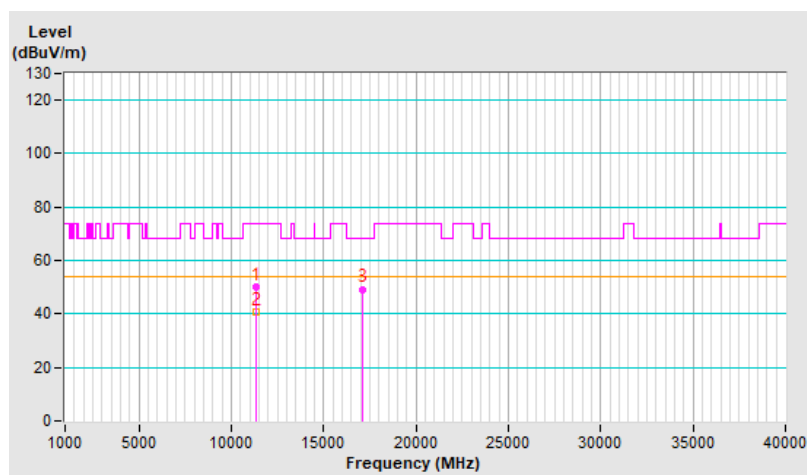

8 Pictures of Test Arrangements

Please refer to the attached file (Test Setup Photo)

9 Information of the Testing Laboratories

We, Bureau Veritas Consumer Products Services (H.K.) Ltd., Taoyuan Branch, were founded in 1988 to provide our best service in EMC, Radio, Telecom and Safety consultation. Our laboratories are FCC recognized accredited test firms and accredited according to ISO/IEC 17025.

If you have any comments, please feel free to contact us at the following:

Lin Kou EMC/RF Lab

Tel: 886-2-26052180

Fax: 886-2-26051924

Hsin Chu EMC/RF/Telecom Lab

Tel: 886-3-6668565

Fax: 886-3-6668323

Hwa Ya EMC/RF/Safety Lab

Tel: 886-3-3183232

Fax: 886-3-3270892

Email: service.adt@bureauveritas.com

Web Site: <http://ee.bureauveritas.com.tw>

The address and road map of all our labs can be found in our web site also.

--- END ---