

TEST REPORT

CERTIFICATE OF CONFORMITY

Standard: 47 CFR FCC Part 15, Subpart C (Section 15.247)

Report No.: RFBARR-WTW-P23040352J-2

FCC ID: RAS-MT7925B22M

Product: 2TX 11be (WiFi7) BW160 + BT/BLE Combo Card

Brand: MediaTek

Model No.: MT7925B22M

Received Date: 2024/3/12

Test Date: 2024/5/7 ~ 2024/5/16

Issued Date: 2024/6/12

Applicant: MediaTek Inc.

Address: No. 1, Dusing 1st Rd., Hsinchu Science Park, Hsinchu City, 30078 Taiwan

Issued By: Bureau Veritas Consumer Products Services (H.K.) Ltd., Taoyuan Branch
Hsin Chu Laboratory

Lab Address: E-2, No.1, Li Hsin 1st Road, Hsinchu Science Park, Hsinchu City 300, Taiwan

Test Location: E-2, No.1, Li Hsin 1st Road, Hsinchu Science Park, Hsinchu City 300, Taiwan

FCC Registration / 723255 / TW2022

Designation Number:

Approved by: _____



May Chen / Manager

Date: _____

2024/6/12

This test report consists of 44 pages in total. It may be duplicated completely for legal use with the approval of the applicant. It should not be reproduced except in full, without the written approval of our laboratory. The test results in the report only apply to the tested sample. The test results in this report are traceable to the national or international standards.



Prepared by : Vito Lung / Specialist

This report is governed by, and incorporates by reference, the Conditions of Testing as posted at the date of issuance of this report at <http://www.bureauveritas.com/home/about-us/our-business/cps/about-us/terms-conditions/> and is intended for your exclusive use. Any copying or replication of this report to or for any other person or entity, or use of our name or trademark, is permitted only with our prior written permission. This report sets forth our findings solely with respect to the test samples identified herein. The results set forth in this report are not indicative or representative of the quality or characteristics of the lot from which a test sample was taken or any similar or identical product unless specifically and expressly noted. Our report includes all of the tests requested by you and the results thereof based upon the information that you provided to us. Measurement uncertainty is only provided upon request for accredited tests. Statements of conformity are based on simple acceptance criteria without taking measurement uncertainty into account, unless otherwise requested in writing. You have 60 days from date of issuance of this report to notify us of any material error or omission caused by our negligence or if you require measurement uncertainty; provided, however, that such notice shall be in writing and shall specifically address the issue you wish to raise. A failure to raise such issue within the prescribed time shall constitute your unqualified acceptance of the completeness of this report, the tests conducted and the correctness of the report contents.

Table of Contents

Release Control Record	3
1 Certificate.....	4
2 Summary of Test Results	5
2.1 Measurement Uncertainty	5
2.2 Supplementary Information	5
3 General Information	6
3.1 General Description	6
3.2 Antenna Description of EUT	7
3.3 Channel List.....	9
3.4 Test Mode Applicability and Tested Channel Detail.....	10
3.5 Duty Cycle of Test Signal.....	11
3.6 Test Program Used and Operation Descriptions	12
3.7 Connection Diagram of EUT and Peripheral Devices	12
3.8 Configuration of Peripheral Devices and Cable Connections	13
4 Test Instruments	14
4.1 AC Power Conducted Emissions	14
4.2 Unwanted Emissions below 1 GHz	15
4.3 Unwanted Emissions above 1 GHz.....	16
5 Limits of Test Items.....	17
5.1 AC Power Conducted Emissions	17
5.2 Unwanted Emissions below 1 GHz	17
5.3 Unwanted Emissions above 1 GHz.....	17
6 Test Arrangements.....	18
6.1 AC Power Conducted Emissions	18
6.1.1 Test Setup	18
6.1.2 Test Procedure.....	18
6.2 Unwanted Emissions below 1 GHz	19
6.2.1 Test Setup	19
6.2.2 Test Procedure.....	20
6.3 Unwanted Emissions above 1 GHz.....	22
6.3.1 Test Setup	22
6.3.2 Test Procedure.....	23
7 Test Results of Test Item	24
7.1 AC Power Conducted Emissions	24
7.2 Unwanted Emissions below 1 GHz	26
7.3 Unwanted Emissions above 1 GHz.....	30
8 Pictures of Test Arrangements	43
9 Information of the Testing Laboratories	44



Release Control Record

Issue No.	Description	Date Issued
RFBARR-WTW-P23040352J-2	Original release.	2024/6/12

1 Certificate

Product: 2TX 11be (WiFi7) BW160 + BT/BLE Combo Card

Brand: MediaTek

Test Model: MT7925B22M

Sample Status: Engineering sample

Applicant: MediaTek Inc.

Test Date: 2024/5/7 ~ 2024/5/16

Standard: 47 CFR FCC Part 15, Subpart C (Section 15.247)

Measurement ANSI C63.10-2013

procedure: KDB 558074 D01 15.247 Meas Guidance v05r02

The above equipment has been tested by **Bureau Veritas Consumer Products Services (H.K.) Ltd., Taoyuan Branch**, and found compliance with the requirement of the above standards. The test record, data evaluation & Equipment Under Test (EUT) configurations represented herein are true and accurate accounts of the measurements of the sample's RF characteristics under the conditions specified in this report.

2 Summary of Test Results

47 CFR FCC Part 15, Subpart C (Section 15.247)			
Standard / Clause	Test Item	Result	Remark
15.247 (a)(1)	RF Output Power	N/A	Refer to Note 1 below
15.247(a)(1) (iii)	Number of Hopping Frequency Used	N/A	Refer to Note 1 below
15.247(a)(1) (iii)	Dwell Time on Each Channel	N/A	Refer to Note 1 below
15.247(a)(1)	Hopping Channel Separation	N/A	Refer to Note 1 below
15.247(a)(1)	20 dB Bandwidth	N/A	Refer to Note 1 below
15.247(d)	Conducted Out of Band Emissions	N/A	Refer to Note 1 below
15.207	AC Power Conducted Emissions	Pass	Minimum passing margin is -9.77 dB at 0.15781 MHz
15.205 / 15.209 / 15.247(d)	Unwanted Emissions below 1 GHz	Pass	Minimum passing margin is -0.3 dB at 299.51 MHz
15.205 / 15.209 / 15.247(d)	Unwanted Emissions above 1 GHz	Pass	Minimum passing margin is -17.4 dB at 7323.00 MHz
15.203	Antenna Requirement	Pass	Antenna connector is i-pex(MHF), R-SMA, RP SMA PLUG, IPEX not a standard connector.

Notes:

1. Only AC Power Conducted Emissions and Unwanted Emissions test items were performed for this addendum. The others testing data refer to original test report.
2. Determining compliance based on the results of the compliance measurement, not taking into account measurement instrumentation uncertainty.

2.1 Measurement Uncertainty

Where relevant, the following measurement uncertainty levels have been estimated for tests performed on the EUT as specified in CISPR 16-4-2:

Parameter	Specification	Expanded Uncertainty (k=2) (±)
AC Power Conducted Emissions	150 kHz ~ 30 MHz	1.9 dB
Unwanted Emissions below 1 GHz	9 kHz ~ 30 MHz	3.1 dB
	30 MHz ~ 1 GHz	5.5 dB
Unwanted Emissions above 1 GHz	1 GHz ~ 18 GHz	5.1 dB
	18 GHz ~ 40 GHz	5.3 dB

The other instruments specified are routine verified to remain within the calibrated levels, no measurement uncertainty is required to be calculated.

2.2 Supplementary Information

There is not any deviation from the test standards for the test method, and no modifications required for compliance.

3 General Information

3.1 General Description

Product	2TX 11be (WiFi7) BW160 + BT/BLE Combo Card
Brand	MediaTek
Test Model	MT7925B22M
Status of EUT	Engineering sample
Power Supply Rating	3.3 Vdc from host equipment
Modulation Type	GFSK, $\pi/4$ -DQPSK, 8DPSK
Modulation Technology	FHSS
Transfer Rate	Up to 3 Mbps
Operating Frequency	2.402 GHz ~ 2.48 GHz
Number of Channel	79
Output Power	19.724 mW (12.95 dBm)

Note:

- This report is prepared for FCC Class II permissive change. The difference compared with the Report No.: RFBARR-WTW-P23040352-2 design is as the following information:
 - ◆ Add Monopole Antenna. (Refer Section 3.2)
- According to above condition, only AC Power Conducted Emissions and Unwanted Emissions needs to be performed. All data for meeting the requirement is verified.
- There are Bluetooth and WLAN (2.4 GHz & 5 GHz & 5.9 GHz & 6 GHz) technology used for the EUT.
- Simultaneously transmission condition.

Condition	Technology	
1	WLAN (2.4 GHz) (1TX)	WLAN (5 GHz) (1TX)
2	WLAN (2.4 GHz) (1TX)	WLAN (5.9 GHz) (1TX)
3	WLAN (2.4 GHz) (1TX)	WLAN (6 GHz) (1TX)
4	WLAN (5 GHz) (1TX)	WLAN (6 GHz) (1TX)
5	WLAN (5 GHz) (2TX)	Bluetooth
6	WLAN (5.9 GHz) (2TX)	Bluetooth
7	WLAN (6GHz) (2TX)	Bluetooth

Note: The emission of the simultaneous operation has been evaluated and no non-compliance was found.

- The EUT has below Sku numbers, which are identical to each other in all aspects except for the following table:

Sku No	Brand	Model	Different
Sku1	MediaTek	MT7925B22M	DVDDIO 3.3V, power from platform.
Sku2	MediaTek	MT7925B22M	DVDDIO 1.8V, power from IC PMU. (Power Management Unit).

- The above EUT information is declared by manufacturer and for more detailed features description, please refer to the manufacturer's specifications or User's Manual.

3.2 Antenna Description of EUT

1. The antenna information is listed as below.

Original								
Antenna Set	RF Chain No.	Brand	Model	Antenna Net Gain (dBi)	Frequency Range (GHz)	Antenna Type	Connector Type	Cable Length (mm)
1	Chain0	PSA	RFMTA340718EMLB302	3.18 4.92	2.4~2.4835 5.15~5.895	PIFA	i-pex(MHF)	200
	Chain1	PSA	RFMTA340718EMLB302	3.18 4.92	2.4~2.4835 5.15~5.895	PIFA	i-pex(MHF)	200
2	Chain0	PSA	RFMTA311020EMMB301	1.71 4.82 4.76 4.29 4.61 4.09	2.4~2.4835 5.15~5.895 5.925~6.425 6.425~6.525 6.525~6.875 6.875~7.125	PIFA	i-pex(MHF)	200
	Chain1	PSA	RFMTA311020EMMB301	1.71 4.82 4.76 4.29 4.61 4.09	2.4~2.4835 5.15~5.895 5.925~6.425 6.425~6.525 6.525~6.875 6.875~7.125	PIFA	i-pex(MHF)	200
3	Chain0	PSA	RFMTA421230IMMB701	-13.92 -13.91 -13.91 -14.46	5.925~6.425 6.425~6.525 6.525~6.875 6.875~7.125	PIFA	i-pex(MHF)	300
	Chain1	PSA	RFMTA421230IMMB701	-13.92 -13.91 -13.91 -14.46	5.925~6.425 6.425~6.525 6.525~6.875 6.875~7.125	PIFA	i-pex(MHF)	300
4	Chain0	Cortec	AN2450-4902BRS	2.42 3.87	2.4~2.4835 5.15~5.895	Dipole	R-SMA	150
	Chain1	Cortec	AN2450-4902BRS	2.42 3.87	2.4~2.4835 5.15~5.895	Dipole	R-SMA	150
5	Chain0	VSO	JR2Q00340-1	1.62 3.2 3.93 3.61 3.61 3.14	2.4~2.4835 5.15~5.895 5.925~6.425 6.425~6.525 6.525~6.875 6.875~7.125	Dipole	RP SMA PLUG	40
	Chain1	VSO	JR2Q00340-1	1.62 3.2 3.93 3.61 3.61 3.14	2.4~2.4835 5.15~5.895 5.925~6.425 6.425~6.525 6.525~6.875 6.875~7.125	Dipole	RP SMA PLUG	40
6	Chain0	PSA	RFPCA460632IMMB701	-13.2 -13.67 -13.67 -13.09	5.925~6.425 6.425~6.525 6.525~6.875 6.875~7.125	Dipole	IPEX	320
	Chain1	PSA	RFPCA460632IMMB701	-13.2 -13.67 -13.67 -13.09	5.925~6.425 6.425~6.525 6.525~6.875 6.875~7.125	Dipole	IPEX	320

Newly								
Antenna Set	RF Chain No.	Brand	Model	Antenna Net Gain (dBi)	Frequency Range (GHz)	Antenna Type	Connector Type	Cable Length (mm)
7	Chain0	HongBo	260-25096	3.11	2.4~2.4835	Monopole	i-pex(MHF)	300
				4.88	5.15~5.895			
				4.91	5.25~5.35			
				4.9	5.47~5.725			
				4.9	5.725~5.85			
				4.87	5.85~5.895			
				4.73	5.925~6.425			
				4.29	6.425~6.525			
				4.58	6.525~6.875			
	4.09	6.875~7.125						
	Chain1	HongBo	260-25096	3.11	2.4~2.4835	Monopole	i-pex(MHF)	300
				4.88	5.15~5.895			
				4.91	5.25~5.35			
				4.9	5.47~5.725			
				4.9	5.725~5.85			
				4.87	5.85~5.895			
				4.73	5.925~6.425			
				4.29	6.425~6.525			
4.58				6.525~6.875				
4.09	6.875~7.125							

* Detail antenna specification please refer to antenna datasheet and/or antenna measurement report.

3.3 Channel List

79 channels are provided for BT-EDR:

Channel	Frequency (MHz)	Channel	Frequency (MHz)	Channel	Frequency (MHz)	Channel	Frequency (MHz)
0	2402	20	2422	40	2442	60	2462
1	2403	21	2423	41	2443	61	2463
2	2404	22	2424	42	2444	62	2464
3	2405	23	2425	43	2445	63	2465
4	2406	24	2426	44	2446	64	2466
5	2407	25	2427	45	2447	65	2467
6	2408	26	2428	46	2448	66	2468
7	2409	27	2429	47	2449	67	2469
8	2410	28	2430	48	2450	68	2470
9	2411	29	2431	49	2451	69	2471
10	2412	30	2432	50	2452	70	2472
11	2413	31	2433	51	2453	71	2473
12	2414	32	2434	52	2454	72	2474
13	2415	33	2435	53	2455	73	2475
14	2416	34	2436	54	2456	74	2476
15	2417	35	2437	55	2457	75	2477
16	2418	36	2438	56	2458	76	2478
17	2419	37	2439	57	2459	77	2479
18	2420	38	2440	58	2460	78	2480
19	2421	39	2441	59	2461		

3.4 Test Mode Applicability and Tested Channel Detail

Pre-Scan:	1. Pre-Scan has been conducted to determine the worst-case mode from all possible combinations between available modulations and data rates.
-----------	--

Following channel(s) was (were) selected for the final test as listed below:

Test Item	EUT Configure Mode	Tested Channel	Modulation	Data Rate Parameter
AC Power Conducted Emissions	C	39	GFSK	DH5
Unwanted Emissions below 1 GHz	A, B	39	GFSK	DH5
Unwanted Emissions above 1 GHz	A, B	0, 39, 78	GFSK	DH5
EUT Configure Mode:	A	EUT only (remove 50 ohm terminator and Connect to the appropriate equipment)		
	B	EUT with 50 ohm terminator		
	C	EUT with antenna (Monopole Ant.)		

Note: The worst SKU is SKU 1. This evaluation condition is determined by referring to the evaluation results of the original report.

3.5 Duty Cycle of Test Signal

GFSK: Duty cycle = $2.869 \text{ ms} / 3.751 \text{ ms} \times 100\% = 76.5\%$, duty factor = $10 * \log (1/\text{Duty cycle}) = 1.16 \text{ dB}$

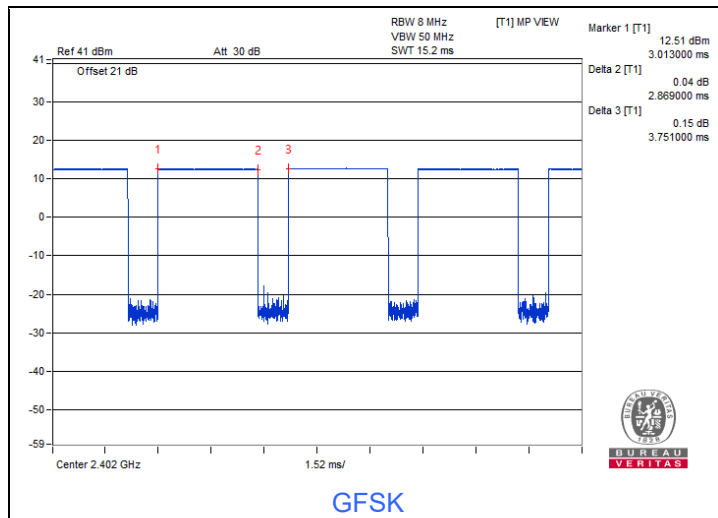

3.6 Test Program Used and Operation Descriptions

Controlling software (WCN_Combotool) has been activated to set the EUT under transmission condition continuously at specific channel frequency.

3.7 Connection Diagram of EUT and Peripheral Devices

For AC Power Conducted Emission test

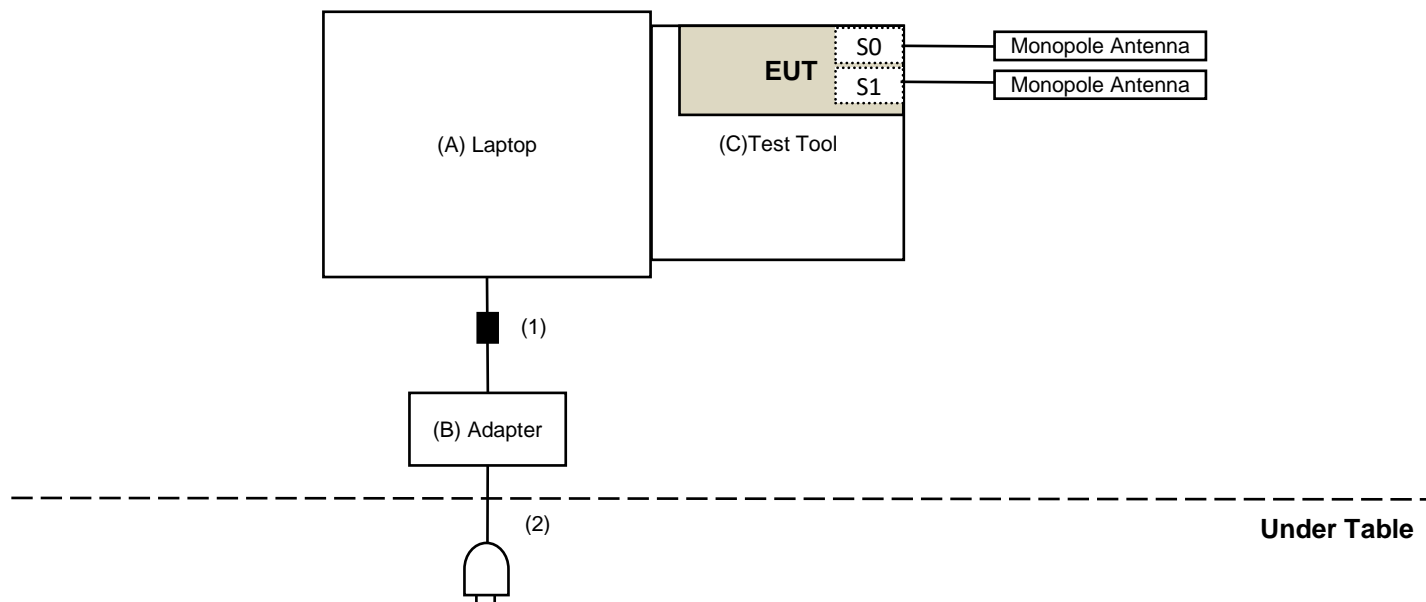

For Unwanted Emission test

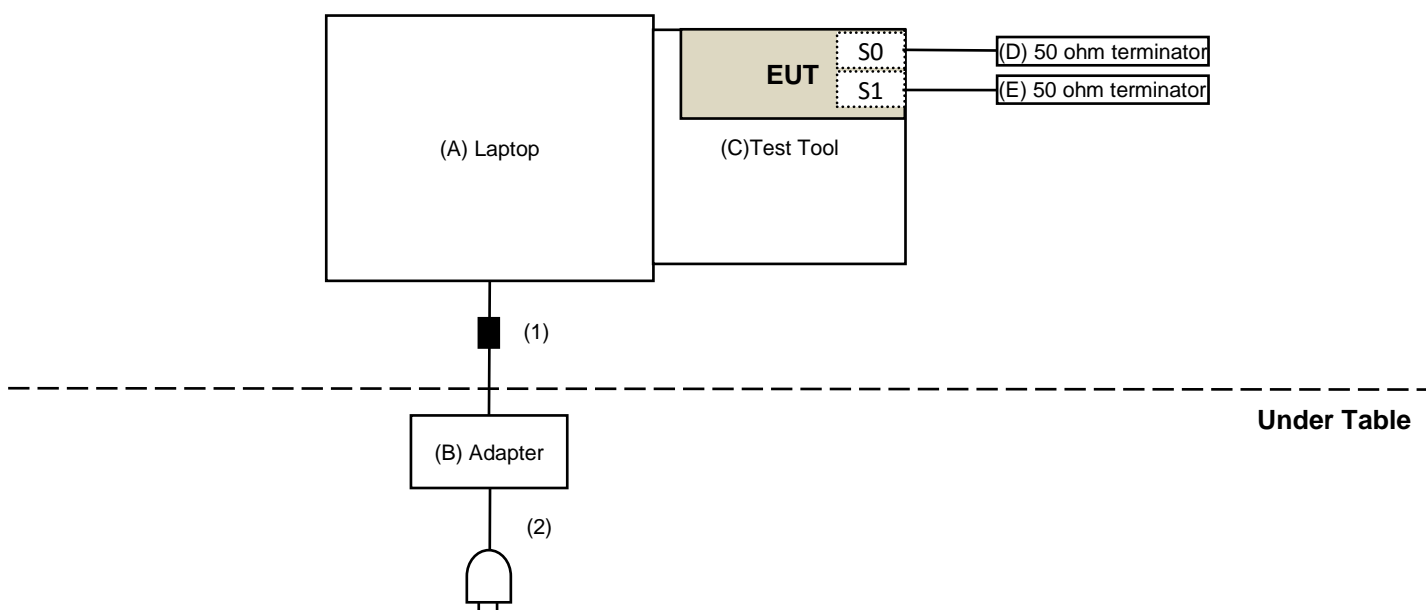

3.8 Configuration of Peripheral Devices and Cable Connections

ID	Product	Brand	Model No.	Serial No.	FCC ID	Remarks
A	Laptop	DELL	E5430	HYV4VY1	DoC	Provided by Lab
B	Adapter	DELL	LLA65NS2-01	N/A	N/A	Provided by Lab
C	Test Tool	Mediatek	MTK1849	N/A	N/A	Supplied by applicant
D	50 Ohm terminator	WOKEN	WTER-18S2	N/A	N/A	Provided by Lab
E	50 Ohm terminator	WOKEN	WTER-18S2	N/A	N/A	Provided by Lab

ID	Cable Descriptions	Qty.	Length (m)	Shielding (Yes/No)	Cores (Qty.)	Remarks
1	DC Cable	1	1.8	No	1	Provided by Lab
2	AC Cable	1	1	No	0	Provided by Lab

4 Test Instruments

The calibration interval of the all test instruments are 12 months and the calibrations are traceable to NML/ROC and NIST/USA.

4.1 AC Power Conducted Emissions

Description Manufacturer	Model No.	Serial No.	Calibrated Date	Calibrated Until
50 ohm terminal resistance Telegartner	50 ohm	3	2023/10/20	2024/10/19
EMI Test Receiver R&S	ESCS 30	847124/029	2023/10/18	2024/10/17
Fixed Attenuator STI	STI02-2200-10	005	2024/2/19	2025/2/18
LISN R&S	ESH3-Z5	835239/001	2024/4/3	2025/4/2
		848773/004	2023/10/13	2024/10/12
RF Coaxial Cable JYEBAO	5D-FB	COCCAB-001	2024/2/19	2025/2/18
Software BVADT	BVADT_Cond_V7.3.7.4	N/A	N/A	N/A

Notes:

1. The test was performed in Conduction 1
2. Tested Date: 2024/5/8

4.2 Unwanted Emissions below 1 GHz

Mode A

Description Manufacturer	Model No.	Serial No.	Calibrated Date	Calibrated Until
MXA Signal Analyzer Keysight	N9020B	MY60112409	2024/2/20	2025/2/19
Software	ADT_RF Test Software V7.6.5.4	N/A	N/A	N/A

Notes:

1. The test was performed in Oven room 2.
2. Tested Date: 2024/5/16

Mode B

Description Manufacturer	Model No.	Serial No.	Calibrated Date	Calibrated Until
Bi_Log Antenna Schwarzbeck	VULB 9168	9168-406	2023/10/13	2024/10/12
Boresight Antenna Tower & Turn Table Max-Full	MF-7802BS	MF780208530	N/A	N/A
Fixed Attenuator Mini-Circuits	UNAT-5+	PAD-ATT5-03	2024/2/17	2025/2/16
Loop Antenna Electro-Metrics	EM-6879	264	2024/2/23	2025/2/22
MXA Signal Analyzer Keysight	N9020B	MY60112408	2024/3/7	2025/3/6
MXE EMI Receiver Keysight	N9038A	MY59050100	2023/6/13	2024/6/12
Preamplifier EMCI	EMC330N	980701	2024/2/17	2025/2/16
	EMC001340	980142	2024/2/19	2025/2/18
RF Coaxial Cable JYEBAO	5D-FB	LOOPCAB-001	2024/2/19	2025/2/18
		LOOPCAB-002	2024/2/19	2025/2/18
RF Coaxial Cable mTJ	100100-CFD400LW-200	CFD400-200	2024/2/17	2025/2/16
	100100-CFD400LW-400	CFD400-400	2024/2/17	2025/2/16
	100100-CFD400LW-800	CFD400-800	2024/2/17	2025/2/16
Software	ADT_Radiated_V8.7.08	N/A	N/A	N/A

Notes:

1. The test was performed in 966 Chamber No. 4.
2. Tested Date: 2024/5/8

4.3 Unwanted Emissions above 1 GHz

Mode A

Refer to section 4.2 to Mode A

Mode B

Description Manufacturer	Model No.	Serial No.	Calibrated Date	Calibrated Until
Boresight Antenna Tower & Turn Table Max-Full	MF-7802BS	MF780208530	N/A	N/A
Horn Antenna Schwarzbeck	BBHA 9120D	9120D-783	2023/11/12	2024/11/11
	BBHA 9170	9170-739	2023/11/12	2024/11/11
MXA Signal Analyzer Keysight	N9020B	MY60112408	2024/3/7	2025/3/6
Preamplifier EMCI	EMC12630SE	980688	2023/10/3	2024/10/2
	EMC184045SE	980387	2023/8/9	2024/8/8
RF Coaxial Cable EMCI	EMC102-KM-KM-1200	160924	2024/1/29	2025/1/28
	EMC102-KM-KM-4000	200214	2024/1/29	2025/1/28
	EMC104-SM-SM-1200	160922	2024/1/29	2025/1/28
	EMC104-SM-SM-2000	180502	2024/1/29	2025/1/28
	EMC104-SM-SM-6000	210704	2023/11/2	2024/11/1
Software	ADT_Radiated_V8.7.08	N/A	N/A	N/A

Notes:

1. The test was performed in 966 Chamber No. 4.
2. Tested Date: 2024/5/7

5 Limits of Test Items

5.1 AC Power Conducted Emissions

Frequency (MHz)	Conducted Limit (dBuV)	
	Quasi-peak	Average
0.15 - 0.5	66 - 56	56 - 46
0.50 - 5.0	56	46
5.0 - 30.0	60	50

Notes:

1. The lower limit shall apply at the transition frequencies.
2. The limit decreases in line with the logarithm of the frequency in the range of 0.15 to 0.50 MHz.

5.2 Unwanted Emissions below 1 GHz

Radiated emissions up to 1 GHz which fall in the restricted bands must comply with the radiated emission limits specified as below table. Other emissions shall be at least 20 dB below the highest level of the desired power:

Frequencies (MHz)	Field Strength (microvolts/meter)	Measurement Distance (meters)
0.009 ~ 0.490	2400/F(kHz)	300
0.490 ~ 1.705	24000/F(kHz)	30
1.705 ~ 30.0	30	30
30 ~ 88	100	3
88 ~ 216	150	3
216 ~ 960	200	3
Above 960	500	3

Notes:

1. The lower limit shall apply at the transition frequencies.
2. Emission level (dBuV/m) = 20 log Emission level (uV/m).

5.3 Unwanted Emissions above 1 GHz

Radiated emissions above 1 GHz which fall in the restricted bands must comply with the radiated emission limits specified as below table. Other emissions shall be at least 20 dB below the highest level of the desired power:

Frequencies (MHz)	Field Strength (microvolts/meter)	Measurement Distance (meters)
Above 960	500	3

Notes:

1. The lower limit shall apply at the transition frequencies.
2. Emission level (dBuV/m) = 20 log Emission level (uV/m).
3. For frequencies above 1000 MHz, the field strength limits are based on average detector, however, the peak field strength of any emission shall not exceed the maximum permitted average limits, specified above by more than 20 dB under any condition of modulation.

6 Test Arrangements

6.1 AC Power Conducted Emissions

6.1.1 Test Setup

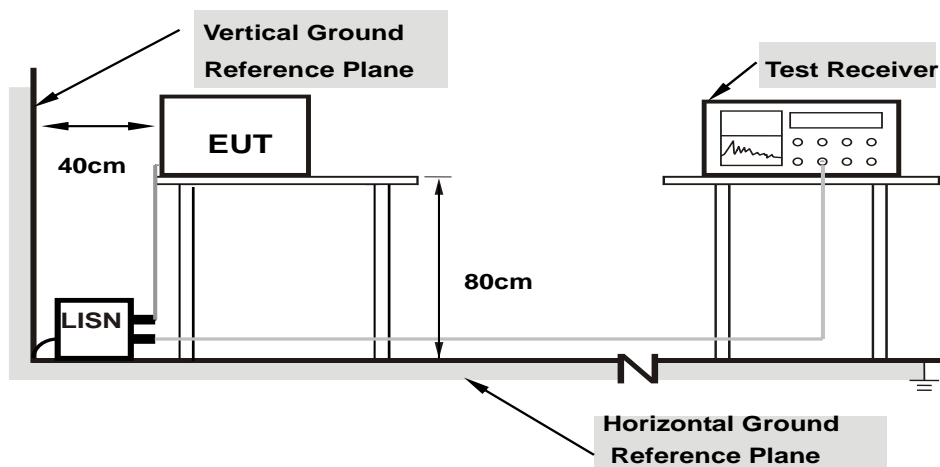

Note: 1.Support units were connected to second LISN.

For the actual test configuration, please refer to the attached file (Test Setup Photo).

6.1.2 Test Procedure

- The EUT was placed on a 0.8 meter to the top of table and placed 0.4 meters from the conducting wall of the shielded room with EUT being connected to the power mains through a line impedance stabilization network (LISN). Other support units were connected to the power mains through another LISN. The two LISNs provide 50 ohm/ 50 uH of coupling impedance for the measuring instrument.
- Both lines of the power mains connected to the EUT were checked for maximum conducted interference.
- The frequency range from 150 kHz to 30 MHz was searched. Emission levels under (Limit – 20 dB) was not recorded.

Note: The resolution bandwidth and video bandwidth of test receiver is 9 kHz for quasi-peak detection (QP) and average detection (AV) at frequency 0.15 MHz-30 MHz.

6.2 Unwanted Emissions below 1 GHz

6.2.1 Test Setup

For Conducted Configuration:

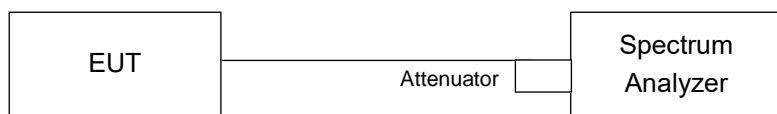

For Radiated Configuration:

For Radiated emission below 30 MHz

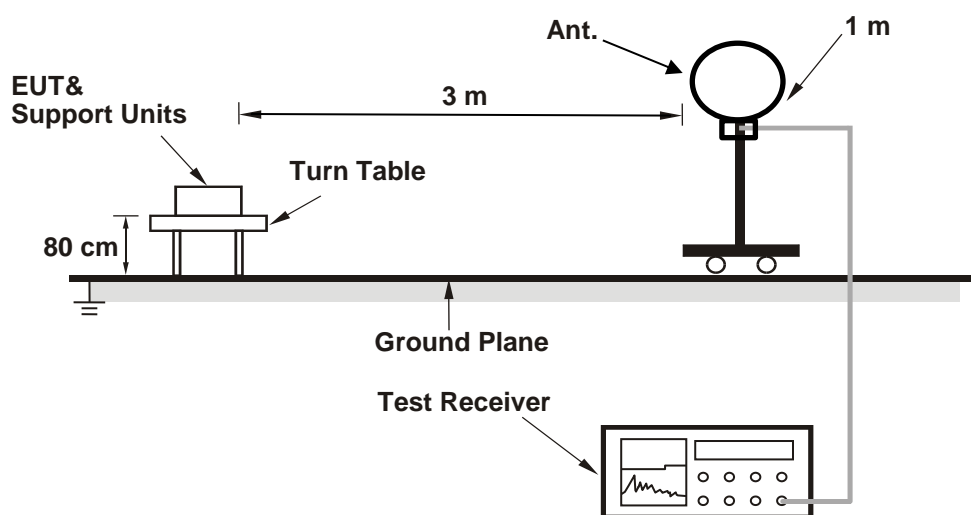

For Radiated emission above 30 MHz

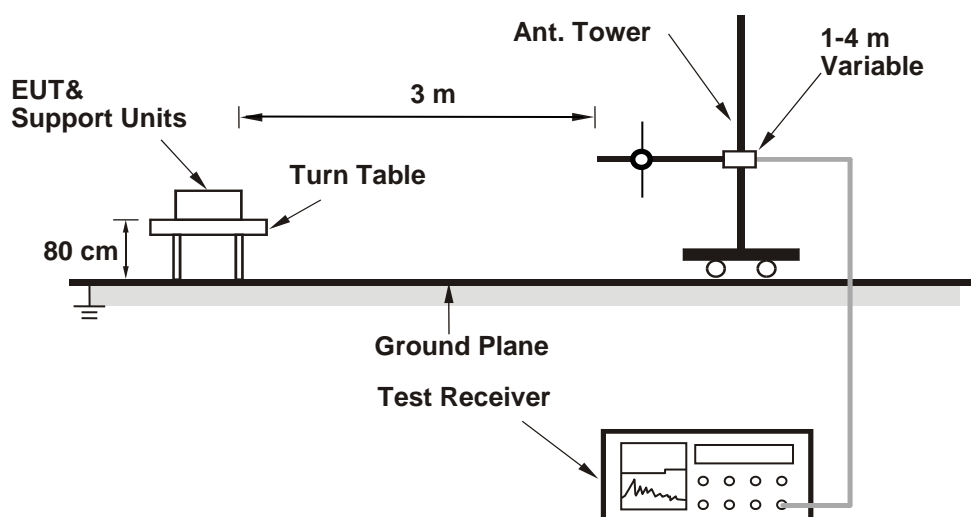

For the actual test configuration, please refer to the attached file (Test Setup Photo).

6.2.2 Test Procedure

Radiated versus Conducted Measurement.

The unwanted emission limits in both the restricted and non-restricted bands are based on antenna-port conducted measurements in conjunction with cabinet emissions tests are permitted to demonstrate compliance.

The following steps was performed:

- a. Cabinet emissions measurements. Radiated measurement was performed to ensure that cabinet emissions are below the emission limits. For the cabinet-emission measurements the antenna was replaced by a termination matching the nominal impedance of the antenna.
- b. Conducted tests was performed using equipment that matches the nominal impedance of the antenna assembly used with the EUT.
- c. EIRP calculation. A value representative of an upper bound on out-of-band antenna gain (in dBi) shall be added to the measured antenna-port conducted emission power to compute EIRP within the specified measurement bandwidth. (For emissions in the restricted bands, additional calculations are required to convert EIRP to field strength at the specified distance.) The upper bound on antenna gain for a device with a single RF output shall be selected as the maximum in-band gain of the antenna across all operating bands or 2 dBi, whichever is greater.
- d. EIRP adjustments for multiple outputs. (Follow the procedures specified in FCC KDB Publication 662911)
- e. For all of Radiation emission test

For Radiated emission below 30 MHz

- e-1.1. The EUT was placed on the top of a rotating table 0.8 meters above the ground at 3 meter chamber room for test. The table was rotated 360 degrees to determine the position of the highest radiation.
- e-1.2. The EUT was set 3 meters away from the interference-receiving antenna, which was mounted on the top of a variable-height antenna tower.
- e-1.3. Parallel, perpendicular, and ground-parallel orientations of the antenna are set to make the measurement.
- e-1.4. For each suspected emission, the EUT was arranged to its worst case and the rotatable table was turned from 0 degrees to 360 degrees to find the maximum reading.
- e-1.5. The test-receiver system was set to Quasi-Peak Detect Function and Specified Bandwidth with Maximum Hold Mode, except for the frequency band (9 kHz to 90 kHz and 110 kHz to 490 kHz) set to average detect function and peak detect function.

Notes:

1. The resolution bandwidth and video bandwidth of test receiver/spectrum analyzer is 200 Hz at frequency below 150 kHz.
2. The resolution bandwidth and video bandwidth of test receiver/spectrum analyzer is 9 kHz or 10 kHz at frequency (150 kHz to 30 MHz).
3. All modes of operation were investigated and the worst-case emissions are reported.

For Radiated emission above 30 MHz

- e-2.1. The EUT was placed on the top of a rotating table 0.8 meters above the ground at 3 meter chamber room for test. The table was rotated 360 degrees to determine the position of the highest radiation.
- e-2.2. The EUT was set 3 meters away from the interference-receiving antenna, which was mounted on the top of a variable-height antenna tower.
- e-2.3. The height of antenna is varied from one meter to four meters above the ground to determine the maximum value of the field strength. Both horizontal and vertical polarizations of the antenna are set to make the measurement.
- e-2.4. For each suspected emission, the EUT was arranged to its worst case and then the antenna was tuned to heights from 1 meter to 4 meters and the rotatable table was turned from 0 degrees to 360 degrees to find the maximum reading.
- e-2.5. The test-receiver system was set to quasi-peak detect function and specified bandwidth with maximum hold mode when the test frequency is below 1 GHz.

Notes:

1. The resolution bandwidth and video bandwidth of test receiver/spectrum analyzer is 120 kHz for Quasi-peak detection (QP), Average detection (AV), Peak detection (PK) at frequency (30MHz to 1 GHz).
2. All modes of operation were investigated and the worst-case emissions are reported.

6.3 Unwanted Emissions above 1 GHz

6.3.1 Test Setup

For Conducted Configuration:

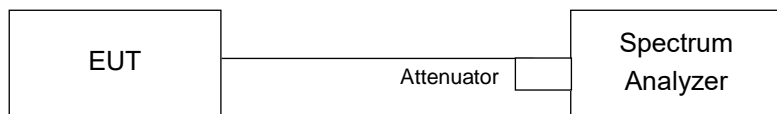

For Radiated Configuration:

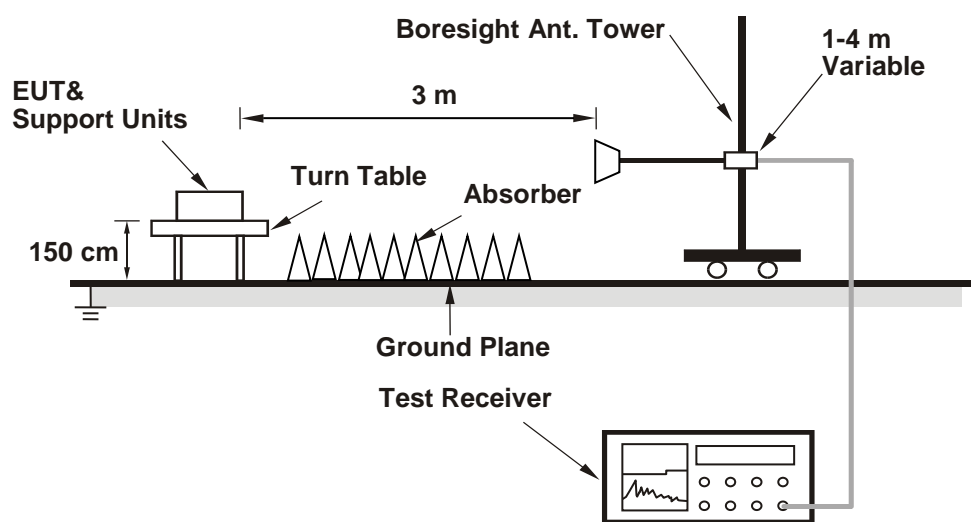

For the actual test configuration, please refer to the attached file (Test Setup Photo).

6.3.2 Test Procedure

Radiated versus Conducted Measurement.

The unwanted emission limits in both the restricted and non-restricted bands are based on antenna-port conducted measurements in conjunction with cabinet emissions tests are permitted to demonstrate compliance.

The following steps was performed:

- a. Cabinet emissions measurements. Radiated measurement was performed to ensure that cabinet emissions are below the emission limits. For the cabinet-emission measurements the antenna was replaced by a termination matching the nominal impedance of the antenna.
- b. Conducted tests was performed using equipment that matches the nominal impedance of the antenna assembly used with the EUT.
- c. EIRP calculation. A value representative of an upper bound on out-of-band antenna gain (in dBi) shall be added to the measured antenna-port conducted emission power to compute EIRP within the specified measurement bandwidth. (For emissions in the restricted bands, additional calculations are required to convert EIRP to field strength at the specified distance.) The upper bound on antenna gain for a device with a single RF output shall be selected as the maximum in-band gain of the antenna across all operating bands or 2 dBi, whichever is greater.
- d. EIRP adjustments for multiple outputs. (Follow the procedures specified in FCC KDB Publication 662911)
- e. For all of Radiation emission test

- e-1. The EUT was placed on the top of a rotating table 1.5 meters above the ground at 3 meter chamber room for test. The table was rotated 360 degrees to determine the position of the highest radiation.
- e-2. The EUT was set 3 meters away from the interference-receiving antenna, which was mounted on the top of a variable-height antenna tower.
- e-3. The height of antenna is varied from one meter to four meters above the ground to determine the maximum value of the field strength. Both horizontal and vertical polarizations of the antenna are set to make the measurement.
- e-4. For each suspected emission, the EUT was arranged to its worst case and then the antenna was tuned to heights from 1 meter to 4 meters and the rotatable table was turned from 0 degrees to 360 degrees to find the maximum reading.
- e-5. The test-receiver system was set to peak and average detects function and specified bandwidth with maximum hold mode when the test frequency is above 1 GHz. If the peak reading value also meets average limit, measurement with the average detector is unnecessary.

Notes:

1. The resolution bandwidth of test receiver/spectrum analyzer is 1 MHz and the video bandwidth is 3 MHz for Peak detection (PK) and Average detection (AV) at frequency above 1 GHz.
2. For fundamental and harmonic signal measurement, the resolution bandwidth of test receiver/spectrum analyzer is 1 MHz and the video bandwidth is $\geq 1/T$ (Duty cycle < 98%) or 10 Hz (Duty cycle $\geq 98\%$) for Average detection (AV) at frequency above 1 GHz.
3. All modes of operation were investigated and the worst-case emissions are reported.

7 Test Results of Test Item

7.1 AC Power Conducted Emissions

Mode C

RF Mode	BT GFSK	Channel	CH 39 : 2441 MHz
Frequency Range	150 kHz ~ 30 MHz	Detector Function & Resolution Bandwidth	Quasi-Peak (QP) / Average (AV), 9 kHz
Input Power (System)	120 Vac, 60 Hz	Environmental Conditions	22 °C, 72 % RH
Tested By	Sampson Chen		

Phase Of Power : Line (L)										
No	Frequency (MHz)	Correction Factor (dB)	Reading Value (dBuV)		Emission Level (dBuV)		Limit (dBuV)		Margin (dB)	
			Q.P.	AV.	Q.P.	AV.	Q.P.	AV.	Q.P.	AV.
1	0.15781	9.94	31.97	16.94	41.91	26.88	65.58	55.58	-23.67	-28.70
2	0.21641	9.94	36.23	12.47	46.17	22.41	62.96	52.96	-16.79	-30.55
3	0.26328	9.94	32.81	15.43	42.75	25.37	61.33	51.33	-18.58	-25.96
4	0.31406	9.95	18.69	1.42	28.64	11.37	59.86	49.86	-31.22	-38.49
5	3.41016	10.12	24.46	16.90	34.58	27.02	56.00	46.00	-21.42	-18.98
6	22.27344	11.06	20.71	15.15	31.77	26.21	60.00	50.00	-28.23	-23.79

Remarks:

1. Q.P. and AV. are abbreviations of quasi-peak and average individually.
2. The emission levels of other frequencies were very low against the limit.
3. Margin value = Emission level – Limit value
4. Correction factor = Insertion loss + Cable loss
5. Emission Level = Correction Factor + Reading Value

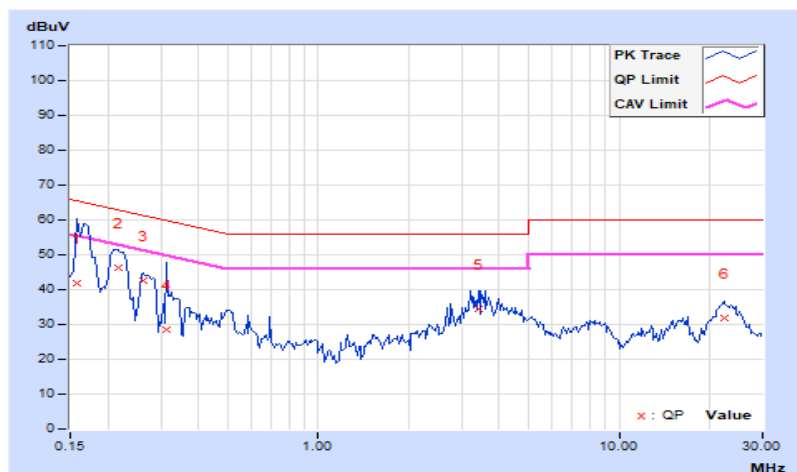

RF Mode	BT GFSK	Channel	CH 39 : 2441 MHz
Frequency Range	150 kHz ~ 30 MHz	Detector Function & Resolution Bandwidth	Quasi-Peak (QP) / Average (AV), 9 kHz
Input Power (System)	120 Vac, 60 Hz	Environmental Conditions	23 °C, 67 % RH
Tested By	Sampson Chen		

Phase Of Power : Neutral (N)										
No	Frequency (MHz)	Correction Factor (dB)	Reading Value (dBuV)		Emission Level (dBuV)		Limit (dBuV)		Margin (dB)	
			Q.P.	AV.	Q.P.	AV.	Q.P.	AV.	Q.P.	AV.
1	0.15781	9.98	45.83	23.83	55.81	33.81	65.58	55.58	-9.77	-21.77
2	0.20469	9.99	32.63	11.59	42.62	21.58	63.42	53.42	-20.80	-31.84
3	0.23594	9.99	35.07	12.81	45.06	22.80	62.24	52.24	-17.18	-29.44
4	0.31016	10.00	20.46	1.14	30.46	11.14	59.97	49.97	-29.51	-38.83
5	0.40391	10.00	16.19	-0.86	26.19	9.14	57.77	47.77	-31.58	-38.63
6	3.92188	10.19	23.44	16.82	33.63	27.01	56.00	46.00	-22.37	-18.99

Remarks:

1. Q.P. and AV. are abbreviations of quasi-peak and average individually.
2. The emission levels of other frequencies were very low against the limit.
3. Margin value = Emission level – Limit value
4. Correction factor = Insertion loss + Cable loss
5. Emission Level = Correction Factor + Reading Value

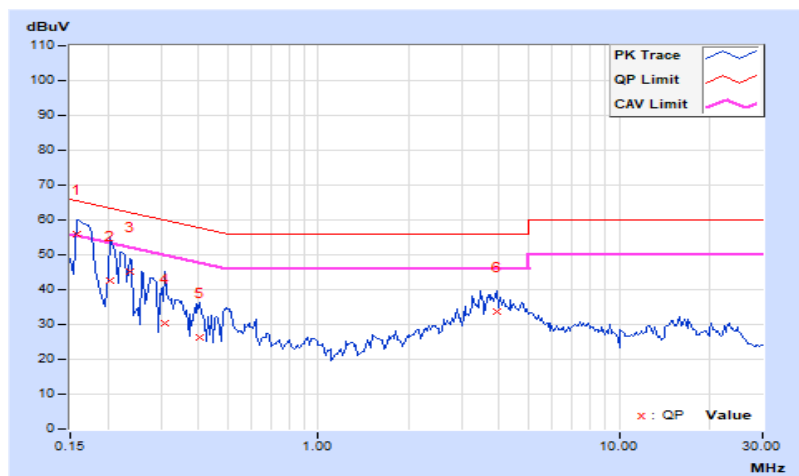

7.2 Unwanted Emissions below 1 GHz

Radiated versus Conducted Measurement

For Radiated measurement:

The level of unwanted emissions was measured when radiated by the cabinet or structure of the equipment with the antenna connector(s) terminated by a specified load (cabinet radiation)

For Conducted measurement:

The level of unwanted emissions was measured as their power in a specified load (conducted spurious emissions).

Conducted Emission Convert Formula

a. $\text{Emission Level (dBuV/m)} = \text{EIRP Level (dBm)} - 20\log(d) + 104.8$

d = measurement distance in 3 meters.

b. $\text{EIRP Level (dBm)} = \text{Raw Value(dBm)} + \text{Correction Factor(dB)}$

c. Correction Factor is directional gain, and the composite gain will be used when signal support the correlated signal

For the out of band spurious the gain for the specific band may have been used rather than the highest gain across all bands.

For the band edge the gain for the specific band may have been used.

Notes:

1. In restricted bands below 1000 MHz, add upper bound on ground plane reflection:

For $f = 30 - 1000$ MHz, add 4.7 dB.

2. The conducted emission test was considered some factor to compute test result.

Mode A
GFSK - Channel 39

Conducted spurious emission table

No.	Frequency (MHz)	Emission Level (dBuV/m)	Limit (dBuV/m)	Margin (dB)	Raw Value (dBm)	Correction Factor (dB)	EIRP Level (dBm)
1	87.23	21.84	40	-18.16	-78.34	4.92	-73.42
2	114.03	22.85	43.5	-20.65	-77.33	4.92	-72.41
3	231.15	22.87	46	-23.13	-77.31	4.92	-72.39
4	435.34	23.91	46	-22.09	-76.27	4.92	-71.35
5	765.5	23.55	46	-22.45	-76.63	4.92	-71.71
6	882.87	24.65	46	-21.35	-75.53	4.92	-70.61

Remarks:

1. Margin value = Emission Level – Limit value
2. The other emission levels were very low against the limit.

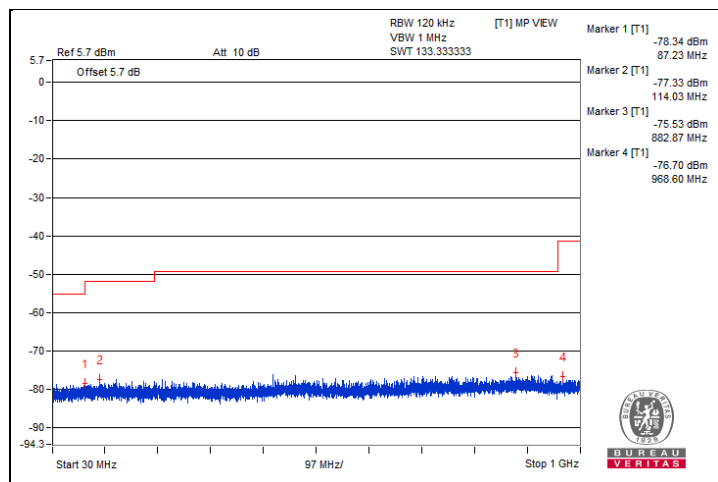

Mode B

RF Mode	BT GFSK	Channel	CH 39 : 2441 MHz
Frequency Range	30 MHz ~ 1 GHz	Detector Function & Bandwidth	QP: RB=120kHz, DET=Quasi-Peak
Input Power (System)	120 Vac, 60 Hz	Environmental Conditions	22.0 °C, 69.0 % RH
Tested By	Sampson Chen		

Antenna Polarity & Test Distance : Horizontal at 3 m								
No	Frequency (MHz)	Emission Level (dBuV/m)	Limit (dBuV/m)	Margin (dB)	Antenna Height (m)	Table Angle (Degree)	Raw Value (dBuV)	Correction Factor (dB/m)
1	215.46	39.8 QP	43.5	-3.7	1.00 H	129	56.2	-16.4
2	239.46	41.7 QP	46.0	-4.3	3.00 H	333	56.2	-14.5
3	299.51	45.7 QP	46.0	-0.3	3.00 H	250	58.1	-12.4
4	326.30	40.2 QP	46.0	-5.8	2.00 H	312	51.7	-11.5
5	701.89	42.7 QP	46.0	-3.3	1.50 H	60	46.6	-3.9
6	840.26	40.7 QP	46.0	-5.3	3.00 H	295	42.3	-1.6

Remarks:

1. Emission Level(dBuV/m) = Raw Value(dBuV) + Correction Factor(dB/m)
2. Correction Factor(dB/m) = Antenna Factor(dB/m) + Cable Factor(dB) – Pre-Amplifier Factor(dB)
3. Margin value = Emission Level – Limit value
4. The other emission levels were very low against the limit of frequency range 30 MHz ~ 1 GHz.
5. The frequency range 9 kHz ~ 30 MHz: all emissions are more than 20 dB below the limit, therefore do not be recorded in this report.

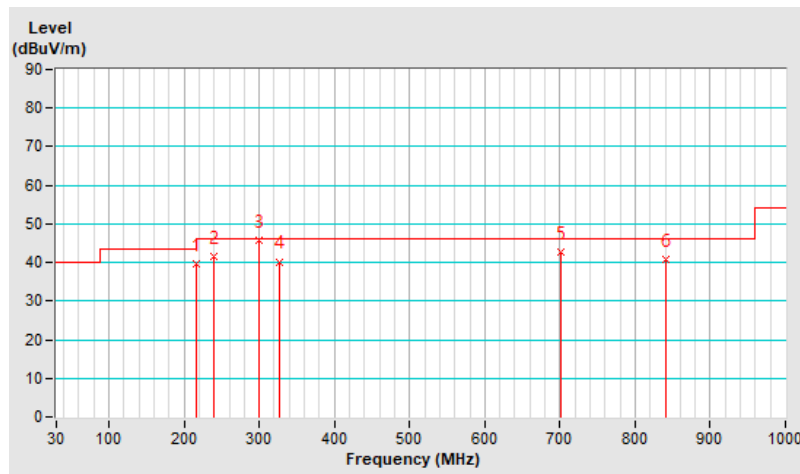

RF Mode	BT GFSK	Channel	CH 39 : 2441 MHz
Frequency Range	30 MHz ~ 1 GHz	Detector Function & Bandwidth	QP: RB=120kHz, DET=Quasi-Peak
Input Power (System)	120 Vac, 60 Hz	Environmental Conditions	22.0 °C, 69.0 % RH
Tested By	Sampson Chen		

Antenna Polarity & Test Distance : Vertical at 3 m								
No	Frequency (MHz)	Emission Level (dBuV/m)	Limit (dBuV/m)	Margin (dB)	Antenna Height (m)	Table Angle (Degree)	Raw Value (dBuV)	Correction Factor (dB/m)
1	100.30	30.0 QP	43.5	-13.5	1.50 V	256	47.1	-17.1
2	145.32	28.1 QP	43.5	-15.4	2.00 V	230	41.0	-12.9
3	244.91	35.8 QP	46.0	-10.2	1.00 V	115	50.1	-14.3
4	301.78	40.7 QP	46.0	-5.3	3.00 V	70	53.0	-12.3
5	336.25	30.7 QP	46.0	-15.3	2.00 V	56	42.1	-11.4
6	700.66	39.6 QP	46.0	-6.4	2.00 V	326	43.5	-3.9

Remarks:

1. Emission Level(dBuV/m) = Raw Value(dBuV) + Correction Factor(dB/m)
2. Correction Factor(dB/m) = Antenna Factor(dB/m) + Cable Factor(dB) – Pre-Amplifier Factor(dB)
3. Margin value = Emission Level – Limit value
4. The other emission levels were very low against the limit of frequency range 30 MHz ~ 1 GHz.
5. The frequency range 9 kHz ~ 30 MHz: all emissions are more than 20 dB below the limit, therefore do not be recorded in this report.

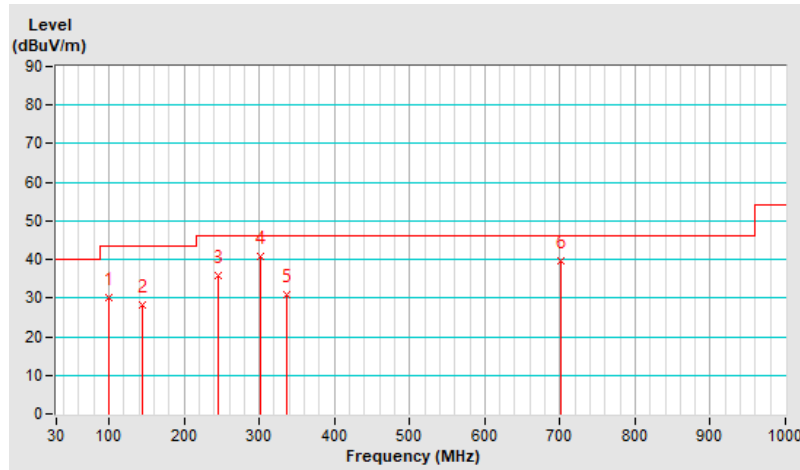

7.3 Unwanted Emissions above 1 GHz

Radiated versus Conducted Measurement

For Radiated measurement:

The level of unwanted emissions was measured when radiated by the cabinet or structure of the equipment with the antenna connector(s) terminated by a specified load (cabinet radiation)

For Conducted measurement:

The level of unwanted emissions was measured as their power in a specified load (conducted spurious emissions).

Conducted Emission Convert Formula

a. $\text{Emission Level (dBuV/m)} = \text{EIRP Level (dBm)} - 20\log(d) + 104.8$

d = measurement distance in 3 meters.

b. $\text{EIRP Level (dBm)} = \text{Raw Value(dBm)} + \text{Correction Factor(dB)}$

c. Correction Factor is directional gain, and the composite gain will be used when signal support the correlated signal

For the out of band spurious the gain for the specific band may have been used rather than the highest gain across all bands.

For the band edge the gain for the specific band may have been used.

Notes: The conducted emission test was considered some factor to compute test result.

**Mode A
GFSK - Channel 0**

Conducted spurious emission table

No.	Frequency (MHz)	Emission Level (dBuV/m)	Limit (dBuV/m)	Margin (dB)	Raw Value (dBm)	Correction Factor (dB)	EIRP Level (dBm)
1	4798.44	63.07 PK	74	-10.93	-37.11	4.92	-32.19
2	4807.81	52.15 AV	54	-1.85	-48.03	4.92	-43.11

Remarks:

1. Margin value = Emission Level – Limit value
2. The other emission levels were very low against the limit.

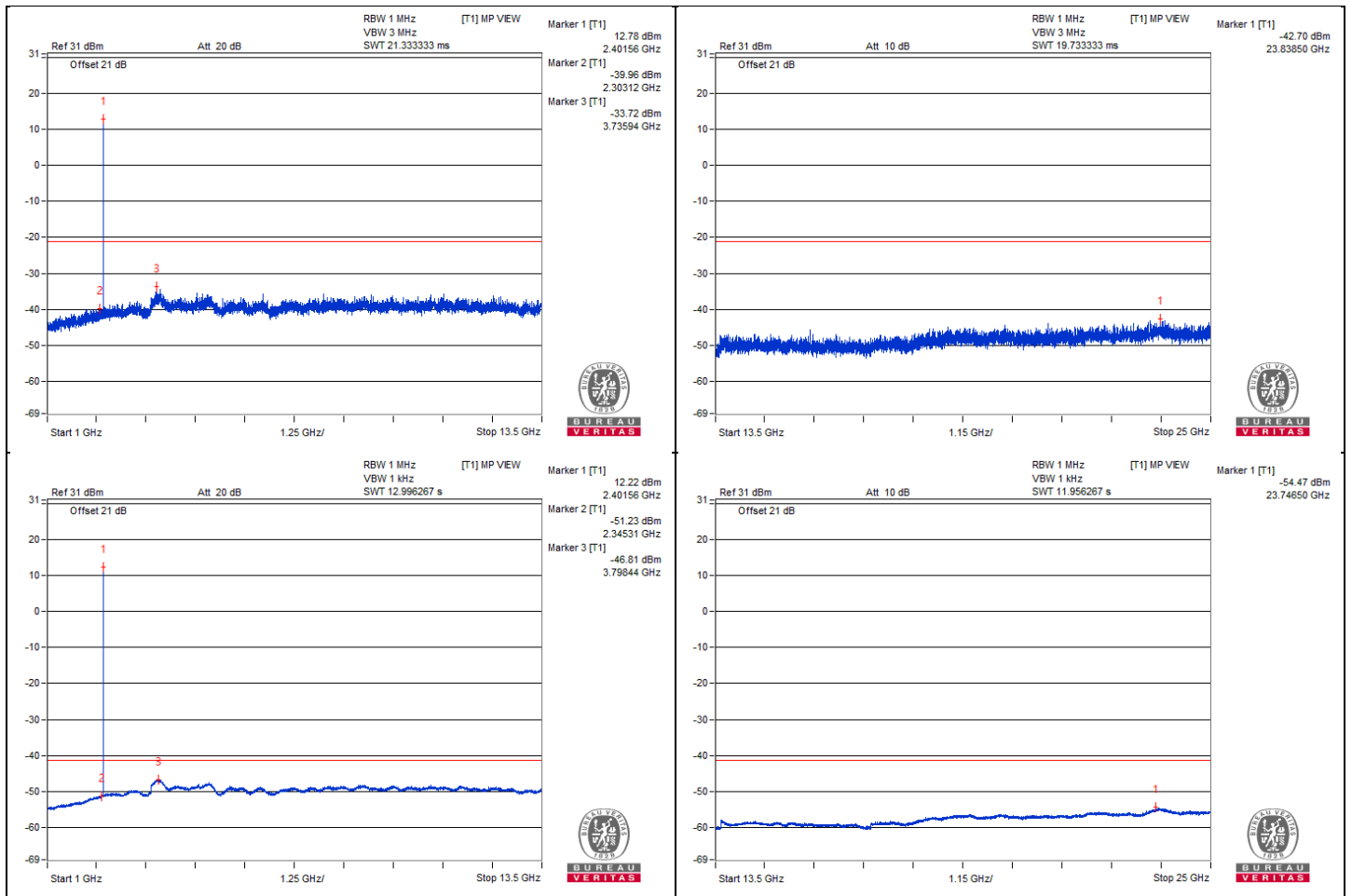

Bandedge table

No.	Frequency (MHz)	Emission Level (dBuV/m)	Limit (dBuV/m)	Margin (dB)	Raw Value (dBm)	Correction Factor (dB)	EIRP Level (dBm)
1	2367.33	59.12 PK	74	-14.88	-39.32	3.18	-36.14
2	2382.51	46.25 AV	54	-7.75	-52.19	3.18	-49.01
3	2490.12	59.35 PK	74	-14.65	-39.09	3.18	-35.91
4	2488.74	46.46 AV	54	-7.54	-51.98	3.18	-48.80

Remarks:

1. Margin value = Emission Level – Limit value
2. The other emission levels were very low against the limit.

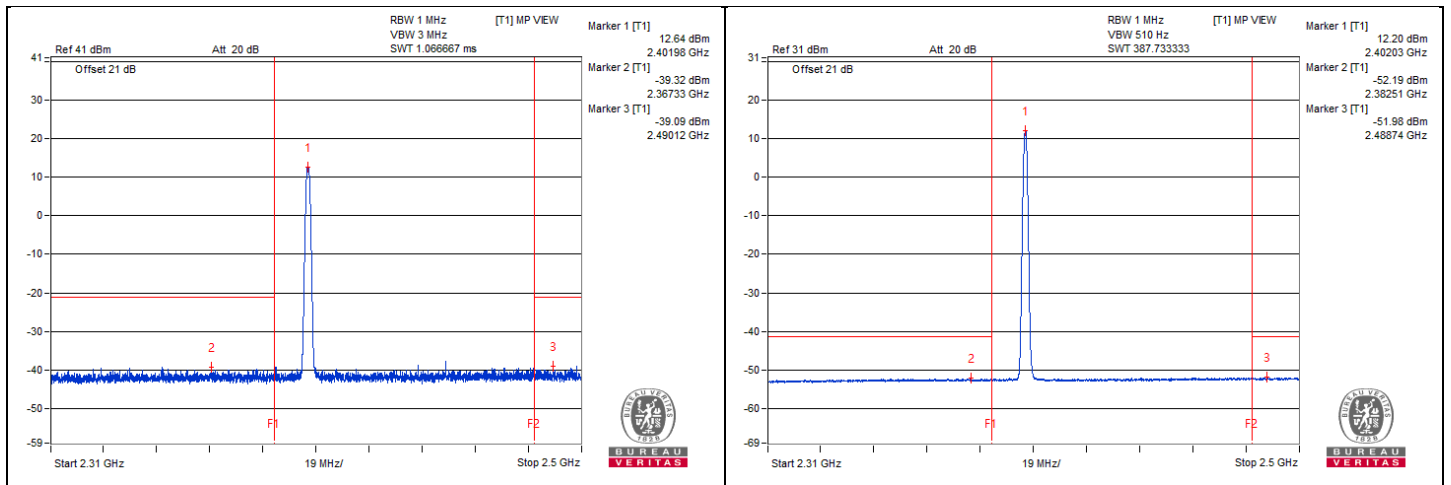

GFSK - Channel 39

Conducted spurious emission table

No.	Frequency (MHz)	Emission Level (dBuV/m)	Limit (dBuV/m)	Margin (dB)	Raw Value (dBm)	Correction Factor (dB)	EIRP Level (dBm)
1	4873.44	63.73 PK	74	-10.27	-36.45	4.92	-31.53
2	4893.75	51.41 AV	54	-2.59	-48.77	4.92	-43.85
3	7325	63.05 PK	74	-10.95	-37.13	4.92	-32.21
4	7321.87	51.01 AV	54	-2.99	-49.17	4.92	-44.25

Remarks:

1. Margin value = Emission Level – Limit value
2. The other emission levels were very low against the limit.

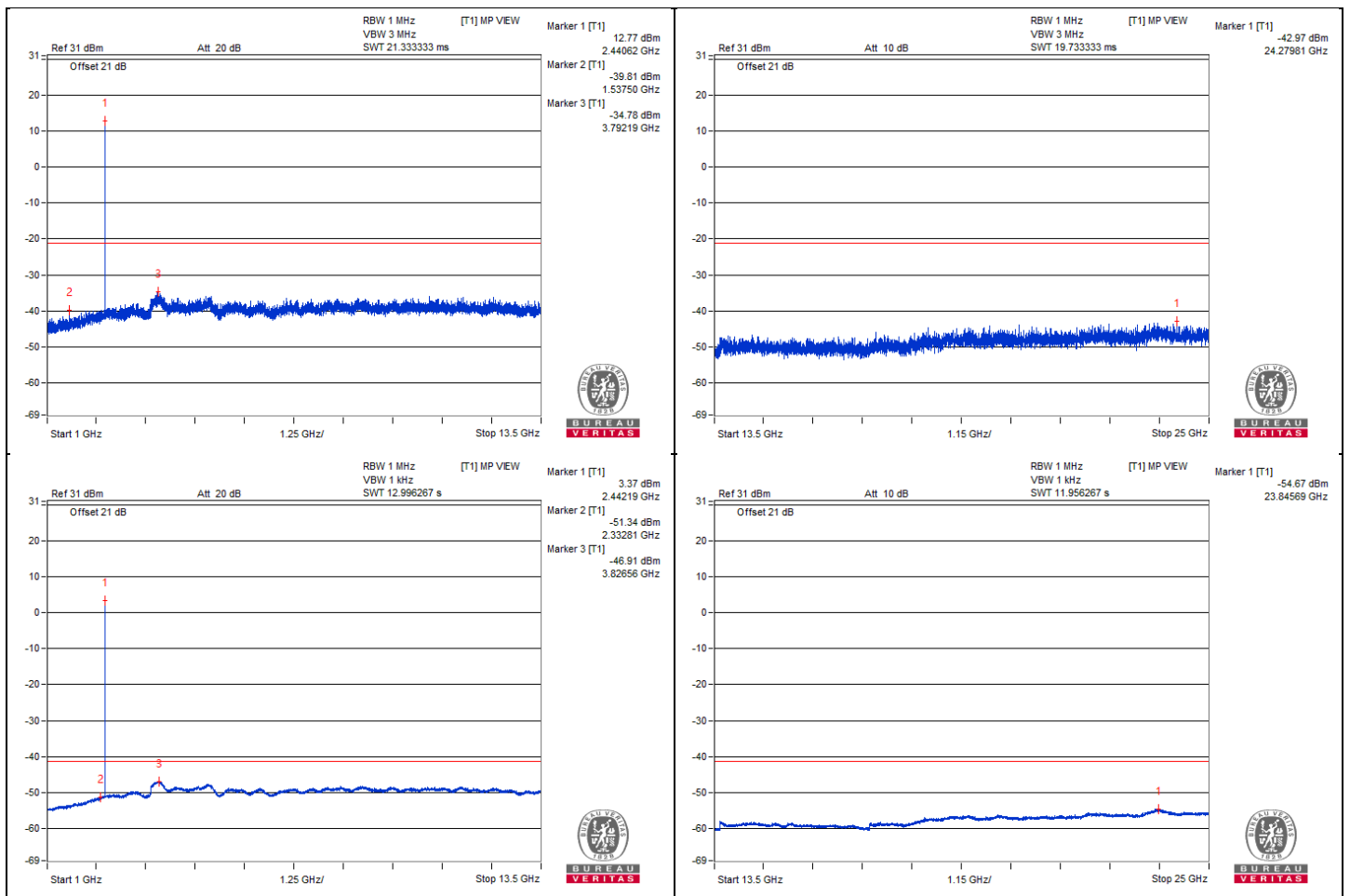

Bandedge table

No.	Frequency (MHz)	Emission Level (dBuV/m)	Limit (dBuV/m)	Margin (dB)	Raw Value (dBm)	Correction Factor (dB)	EIRP Level (dBm)
1	2369.47	59.21 PK	74	-14.79	-39.23	3.18	-36.05
2	2382.84	46.21 AV	54	-7.79	-52.23	3.18	-49.05
3	2496.03	59.2 PK	74	-14.8	-39.24	3.18	-36.06
4	2489.91	46.46 AV	54	-7.54	-51.98	3.18	-48.80

Remarks:

1. Margin value = Emission Level – Limit value
2. The other emission levels were very low against the limit.

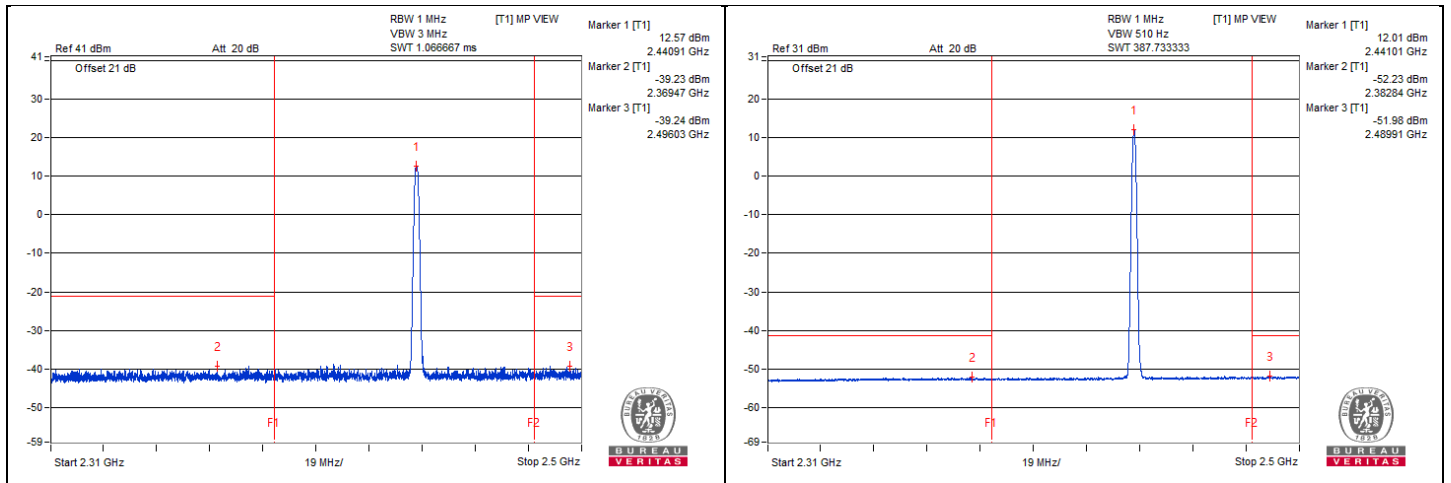

GFSK - Channel 78

Conducted spurious emission table

No.	Frequency (MHz)	Emission Level (dBuV/m)	Limit (dBuV/m)	Margin (dB)	Raw Value (dBm)	Correction Factor (dB)	EIRP Level (dBm)
1	4973.44	62.8 PK	74	-11.2	-37.38	4.92	-32.46
2	4965.62	52.06 AV	54	-1.94	-48.12	4.92	-43.20
3	7421.87	63.07 PK	74	-10.93	-37.11	4.92	-32.19
4	7440.62	50.82 AV	54	-3.18	-49.36	4.92	-44.44

Remarks:

1. Margin value = Emission Level – Limit value
2. The other emission levels were very low against the limit.

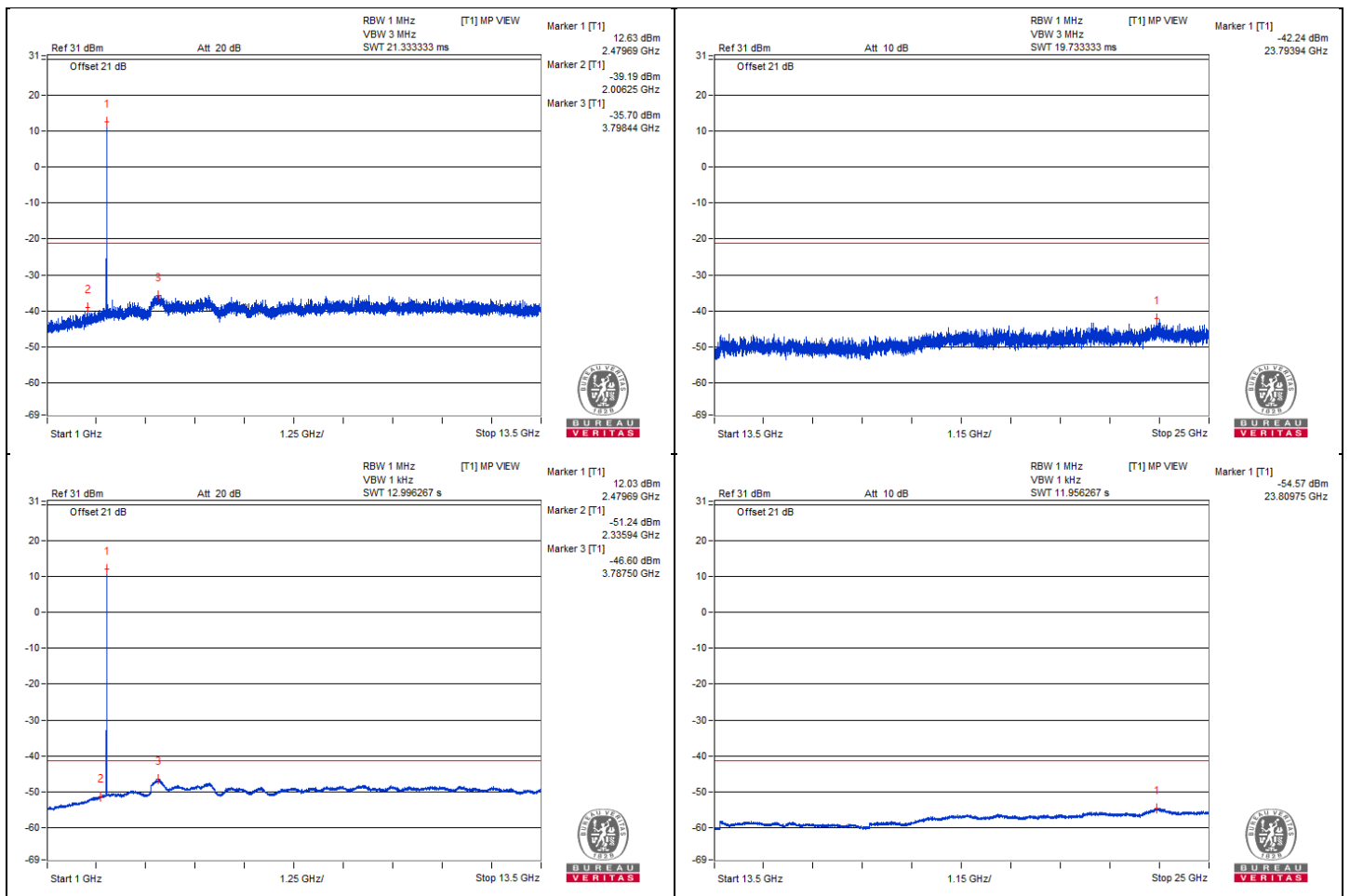

Bandedge table

No.	Frequency (MHz)	Emission Level (dBuV/m)	Limit (dBuV/m)	Margin (dB)	Raw Value (dBm)	Correction Factor (dB)	EIRP Level (dBm)
1	2382.51	58.5 PK	74	-15.5	-39.94	3.18	-36.76
2	2369.66	46.14 AV	54	-7.86	-52.3	3.18	-49.12
3	2491.21	58.97 PK	74	-15.03	-39.47	3.18	-36.29
4	2484.49	46.65 AV	54	-7.35	-51.79	3.18	-48.61

Remarks:

1. Margin value = Emission Level – Limit value
2. The other emission levels were very low against the limit.

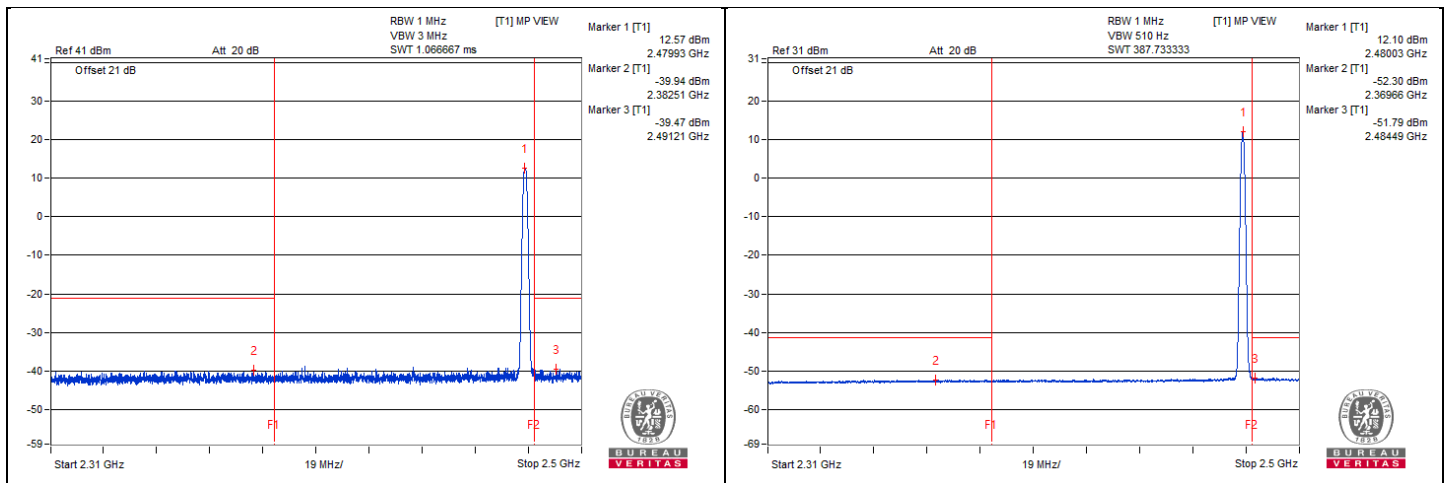

Mode B

RF Mode	BT GFSK	Channel	CH 0 : 2402 MHz
Frequency Range	1 GHz ~ 25 GHz	Detector Function & Bandwidth	PK: RB=1 MHz, VB=3 MHz, DET=Peak AV: RB=1 MHz, VB=510 Hz, DET=Peak
Input Power (System)	120 Vac, 60 Hz	Environmental Conditions	24.0 °C, 68.0 % RH
Tested By	Sampson Chen		

Antenna Polarity & Test Distance : Horizontal at 3 m								
No	Frequency (MHz)	Emission Level (dBuV/m)	Limit (dBuV/m)	Margin (dB)	Antenna Height (m)	Table Angle (Degree)	Raw Value (dBuV)	Correction Factor (dB/m)
1	4804.00	41.6 PK	74.0	-32.4	1.63 H	322	37.0	4.6
2	4804.00	29.9 AV	54.0	-24.1	1.63 H	322	25.3	4.6

Remarks:

1. Emission Level(dBuV/m) = Raw Value(dBuV) + Correction Factor(dB/m)
2. Correction Factor(dB/m) = Antenna Factor(dB/m) + Cable Factor(dB) – Pre-Amplifier Factor(dB)
3. Margin value = Emission Level – Limit value
4. The other emission levels were very low against the limit.

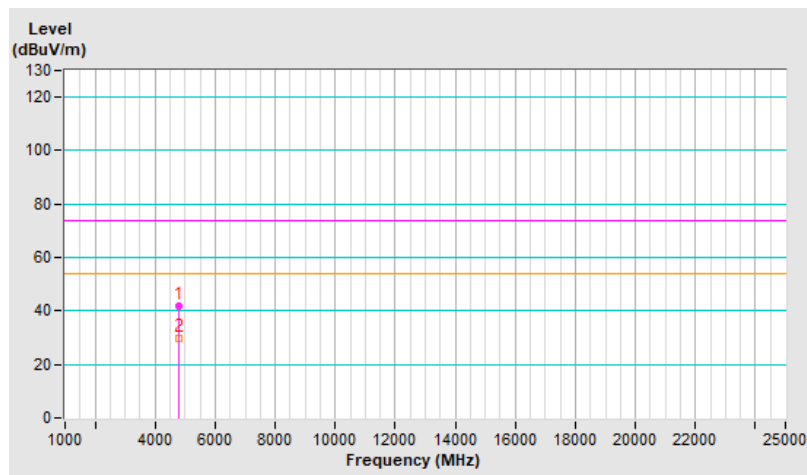

RF Mode	BT GFSK	Channel	CH 0 : 2402 MHz
Frequency Range	1 GHz ~ 25 GHz	Detector Function & Bandwidth	PK: RB=1 MHz, VB=3 MHz, DET=Peak AV: RB=1 MHz, VB=510 Hz, DET=Peak
Input Power (System)	120 Vac, 60 Hz	Environmental Conditions	24.0 °C, 68.0 % RH
Tested By	Sampson Chen		

Antenna Polarity & Test Distance : Vertical at 3 m								
No	Frequency (MHz)	Emission Level (dBuV/m)	Limit (dBuV/m)	Margin (dB)	Antenna Height (m)	Table Angle (Degree)	Raw Value (dBuV)	Correction Factor (dB/m)
1	4804.00	41.7 PK	74.0	-32.3	2.94 V	72	37.1	4.6
2	4804.00	28.9 AV	54.0	-25.1	2.94 V	72	24.3	4.6

Remarks:

1. Emission Level(dBuV/m) = Raw Value(dBuV) + Correction Factor(dB/m)
2. Correction Factor(dB/m) = Antenna Factor(dB/m) + Cable Factor(dB) – Pre-Amplifier Factor(dB)
3. Margin value = Emission Level – Limit value
4. The other emission levels were very low against the limit.

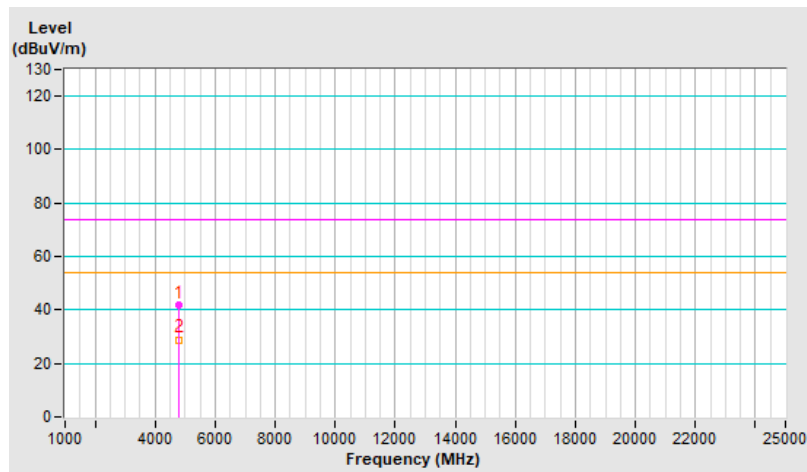

RF Mode	BT GFSK	Channel	CH 39 : 2441 MHz
Frequency Range	1 GHz ~ 25 GHz	Detector Function & Bandwidth	PK: RB=1 MHz, VB=3 MHz, DET=Peak AV: RB=1 MHz, VB=510 Hz, DET=Peak
Input Power (System)	120 Vac, 60 Hz	Environmental Conditions	24.0 °C, 68.0 % RH
Tested By	Sampson Chen		

Antenna Polarity & Test Distance : Horizontal at 3 m								
No	Frequency (MHz)	Emission Level (dBuV/m)	Limit (dBuV/m)	Margin (dB)	Antenna Height (m)	Table Angle (Degree)	Raw Value (dBuV)	Correction Factor (dB/m)
1	4882.00	41.5 PK	74.0	-32.5	1.59 H	330	36.9	4.6
2	4882.00	29.8 AV	54.0	-24.2	1.59 H	330	25.2	4.6
3	7323.00	45.6 PK	74.0	-28.4	1.58 H	165	34.0	11.6
4	7323.00	35.5 AV	54.0	-18.5	1.58 H	165	23.9	11.6

Remarks:

1. Emission Level(dBuV/m) = Raw Value(dBuV) + Correction Factor(dB/m)
2. Correction Factor(dB/m) = Antenna Factor(dB/m) + Cable Factor(dB) – Pre-Amplifier Factor(dB)
3. Margin value = Emission Level – Limit value
4. The other emission levels were very low against the limit.

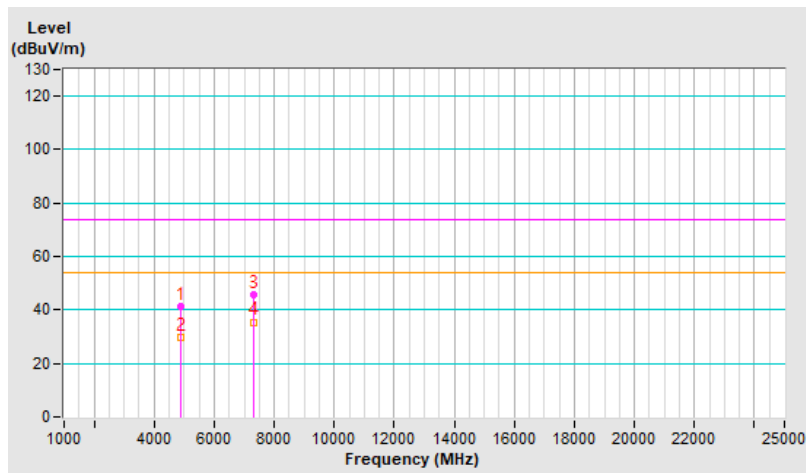

RF Mode	BT GFSK	Channel	CH 39 : 2441 MHz
Frequency Range	1 GHz ~ 25 GHz	Detector Function & Bandwidth	PK: RB=1 MHz, VB=3 MHz, DET=Peak AV: RB=1 MHz, VB=510 Hz, DET=Peak
Input Power (System)	120 Vac, 60 Hz	Environmental Conditions	24.0 °C, 68.0 % RH
Tested By	Sampson Chen		

Antenna Polarity & Test Distance : Vertical at 3 m								
No	Frequency (MHz)	Emission Level (dBuV/m)	Limit (dBuV/m)	Margin (dB)	Antenna Height (m)	Table Angle (Degree)	Raw Value (dBuV)	Correction Factor (dB/m)
1	4882.00	41.7 PK	74.0	-32.3	2.89 V	57	37.1	4.6
2	4882.00	28.9 AV	54.0	-25.1	2.89 V	57	24.3	4.6
3	7323.00	46.6 PK	74.0	-27.4	3.11 V	89	35.0	11.6
4	7323.00	36.6 AV	54.0	-17.4	3.11 V	89	25.0	11.6

Remarks:

1. Emission Level(dBuV/m) = Raw Value(dBuV) + Correction Factor(dB/m)
2. Correction Factor(dB/m) = Antenna Factor(dB/m) + Cable Factor(dB) – Pre-Amplifier Factor(dB)
3. Margin value = Emission Level – Limit value
4. The other emission levels were very low against the limit.

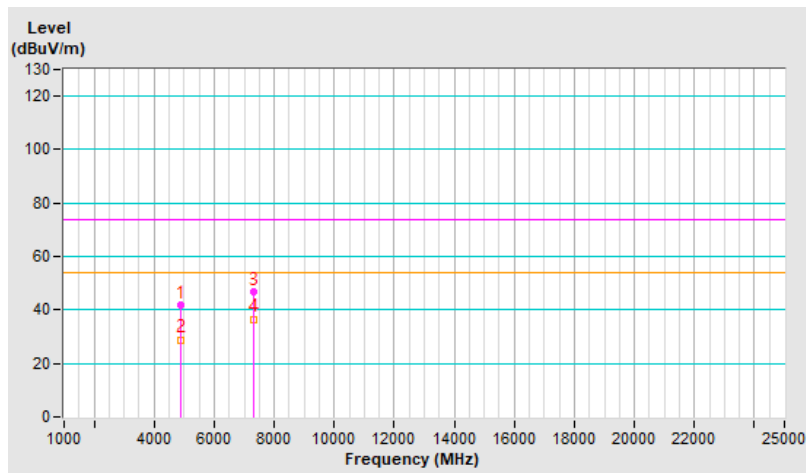

RF Mode	BT GFSK	Channel	CH 78 : 2480 MHz
Frequency Range	1 GHz ~ 25 GHz	Detector Function & Bandwidth	PK: RB=1 MHz, VB=3 MHz, DET=Peak AV: RB=1 MHz, VB=510 Hz, DET=Peak
Input Power (System)	120 Vac, 60 Hz	Environmental Conditions	24.0 °C, 68.0 % RH
Tested By	Sampson Chen		

Antenna Polarity & Test Distance : Horizontal at 3 m								
No	Frequency (MHz)	Emission Level (dBuV/m)	Limit (dBuV/m)	Margin (dB)	Antenna Height (m)	Table Angle (Degree)	Raw Value (dBuV)	Correction Factor (dB/m)
1	4960.00	41.0 PK	74.0	-33.0	1.54 H	323	36.0	5.0
2	4960.00	32.2 AV	54.0	-21.8	1.54 H	323	27.2	5.0
3	7440.00	46.4 PK	74.0	-27.6	1.55 H	174	34.5	11.9
4	7440.00	34.3 AV	54.0	-19.7	1.55 H	174	22.4	11.9

Remarks:

1. Emission Level(dBuV/m) = Raw Value(dBuV) + Correction Factor(dB/m)
2. Correction Factor(dB/m) = Antenna Factor(dB/m) + Cable Factor(dB) – Pre-Amplifier Factor(dB)
3. Margin value = Emission Level – Limit value
4. The other emission levels were very low against the limit.

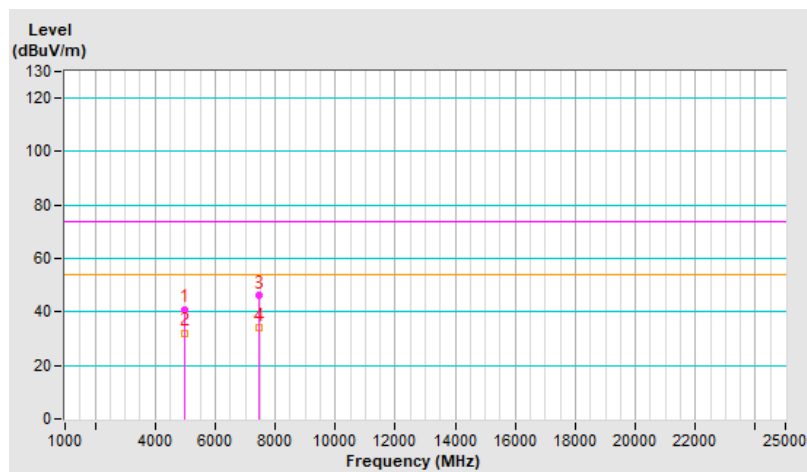

RF Mode	BT GFSK	Channel	CH 78 : 2480 MHz
Frequency Range	1 GHz ~ 25 GHz	Detector Function & Bandwidth	PK: RB=1 MHz, VB=3 MHz, DET=Peak AV: RB=1 MHz, VB=510 Hz, DET=Peak
Input Power (System)	120 Vac, 60 Hz	Environmental Conditions	24.0 °C, 68.0 % RH
Tested By	Sampson Chen		

Antenna Polarity & Test Distance : Vertical at 3 m								
No	Frequency (MHz)	Emission Level (dBuV/m)	Limit (dBuV/m)	Margin (dB)	Antenna Height (m)	Table Angle (Degree)	Raw Value (dBuV)	Correction Factor (dB/m)
1	4960.00	41.7 PK	74.0	-32.3	2.87 V	65	36.7	5.0
2	4960.00	29.1 AV	54.0	-24.9	2.87 V	65	24.1	5.0
3	7440.00	46.2 PK	74.0	-27.8	3.15 V	91	34.3	11.9
4	7440.00	36.3 AV	54.0	-17.7	3.15 V	91	24.4	11.9

Remarks:

1. Emission Level(dBuV/m) = Raw Value(dBuV) + Correction Factor(dB/m)
2. Correction Factor(dB/m) = Antenna Factor(dB/m) + Cable Factor(dB) – Pre-Amplifier Factor(dB)
3. Margin value = Emission Level – Limit value
4. The other emission levels were very low against the limit.

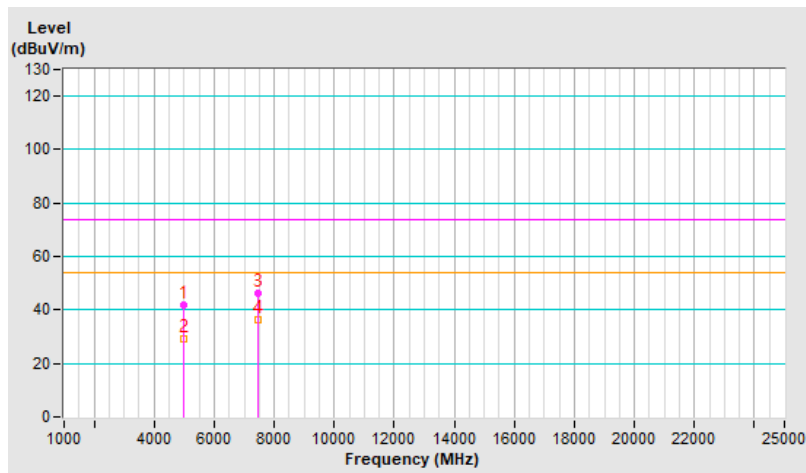

8 Pictures of Test Arrangements

Please refer to the attached file (Test Setup Photo)

9 Information of the Testing Laboratories

We, Bureau Veritas Consumer Products Services (H.K.) Ltd., Taoyuan Branch, were founded in 1988 to provide our best service in EMC, Radio, Telecom and Safety consultation. Our laboratories are FCC recognized accredited test firms and accredited according to ISO/IEC 17025.

If you have any comments, please feel free to contact us at the following:

Lin Kou EMC/RF Lab

Tel: 886-2-26052180

Fax: 886-2-26051924

Hsin Chu EMC/RF/Telecom Lab

Tel: 886-3-6668565

Fax: 886-3-6668323

Hwa Ya EMC/RF/Safety Lab

Tel: 886-3-3183232

Fax: 886-3-3270892

Email: service.adt@bureauveritas.com

Web Site: <http://ee.bureauveritas.com.tw>

The address and road map of all our labs can be found in our web site also.

--- END ---