

# TEST REPORT

## CERTIFICATE OF CONFORMITY

**Standard:** 47 CFR FCC Part 15, Subpart E (Section 15.407)  
**Report No.:** RFBARR-WTW-P23040352I-1  
**FCC ID:** RAS-MT7925B22M  
**Product:** 2TX 11be (WiFi7) BW160 + BT/BLE Combo Card  
**Brand:** MediaTek  
**Model No.:** MT7925B22M  
**Received Date:** 2023/7/11  
**Test Date:** 2023/7/11 ~ 2024/3/16  
**Issued Date:** 2024/4/10

**Applicant:** MediaTek Inc.

**Address:** No. 1, Dusing 1st Rd., Hsinchu Science Park, Hsinchu City, 30078 Taiwan

**Issued By:** Bureau Veritas Consumer Products Services (H.K.) Ltd., Taoyuan Branch  
Hsin Chu Laboratory

**Lab Address:** E-2, No.1, Li Hsin 1st Road, Hsinchu Science Park, Hsinchu City 300, Taiwan

**Test Location:** E-2, No.1, Li Hsin 1st Road, Hsinchu Science Park, Hsinchu City 300, Taiwan

**FCC Registration /** 723255 / TW2022

**Designation Number:**

**Approved by:** \_\_\_\_\_



**Date:** \_\_\_\_\_

2024/4/10

Wen Yu / Assistant Manager

This test report consists of 572 pages in total. It may be duplicated completely for legal use with the approval of the applicant. It should not be reproduced except in full, without the written approval of our laboratory. The test results in the report only apply to the tested sample. The test results in this report are traceable to the national or international standards.



Prepared by : Phoenix Huang / Specialist

This report is governed by, and incorporates by reference, the Conditions of Testing as posted at the date of issuance of this report at <http://www.bureauveritas.com/home/about-us/our-business/cps/about-us/terms-conditions/> and is intended for your exclusive use. Any copying or replication of this report to or for any other person or entity, or use of our name or trademark, is permitted only with our prior written permission. This report sets forth our findings solely with respect to the test samples identified herein. The results set forth in this report are not indicative or representative of the quality or characteristics of the lot from which a test sample was taken or any similar or identical product unless specifically and expressly noted. Our report includes all of the tests requested by you and the results thereof based upon the information that you provided to us. Measurement uncertainty is only provided upon request for accredited tests. Statements of conformity are based on simple acceptance criteria without taking measurement uncertainty into account, unless otherwise requested in writing. You have 60 days from date of issuance of this report to notify us of any material error or omission caused by our negligence or if you require measurement uncertainty; provided, however, that such notice shall be in writing and shall specifically address the issue you wish to raise. A failure to raise such issue within the prescribed time shall constitute your unqualified acceptance of the completeness of this report, the tests conducted and the correctness of the report contents.

## Table of Contents

<b>Release Control Record</b> .....	<b>4</b>
<b>1 Certificate</b> .....	<b>5</b>
<b>2 Summary of Test Results</b> .....	<b>6</b>
2.1 Measurement Uncertainty .....	6
2.2 Supplementary Information .....	7
<b>3 General Information</b> .....	<b>8</b>
3.1 General Description of EUT .....	8
3.2 Antenna Description of EUT .....	10
3.3 Channel List .....	12
3.4 Test Mode Applicability and Tested Channel Detail .....	13
3.5 Duty Cycle of Test Signal .....	18
3.6 Test Program Used and Operation Descriptions .....	24
3.7 Connection Diagram of EUT and Peripheral Devices .....	24
3.8 Configuration of Peripheral Devices and Cable Connections .....	25
<b>4 Test Instruments</b> .....	<b>26</b>
4.1 26 dB Bandwidth .....	26
4.2 RF Output Power .....	26
4.3 Power Spectral Density .....	26
4.4 6 dB Bandwidth .....	26
4.5 Occupied Bandwidth .....	26
4.6 Frequency Stability .....	27
4.7 AC Power Conducted Emissions .....	27
4.8 Unwanted Emissions below 1 GHz .....	28
4.9 Unwanted Emissions above 1 GHz .....	29
<b>5 Limits of Test Items</b> .....	<b>30</b>
5.1 26 dB Bandwidth .....	30
5.2 RF Output Power .....	30
5.3 Power Spectral Density .....	30
5.4 6 dB Bandwidth .....	30
5.5 Occupied Bandwidth .....	31
5.6 Frequency Stability .....	31
5.7 AC Power Conducted Emissions .....	31
5.8 Unwanted Emissions below 1 GHz .....	31
5.9 Unwanted Emissions above 1 GHz .....	32
<b>6 Test Arrangements</b> .....	<b>33</b>
6.1 26 dB Bandwidth .....	33
6.1.1 Test Setup .....	33
6.1.2 Test Procedure .....	33
6.2 RF Output Power .....	33
6.2.1 Test Setup .....	33
6.2.2 Test Procedure .....	33
6.3 Power Spectral Density .....	34
6.3.1 Test Setup .....	34
6.3.2 Test Procedure .....	34
6.4 6 dB Bandwidth .....	34
6.4.1 Test Setup .....	34
6.4.2 Test Procedure .....	34
6.5 Occupied Bandwidth .....	35
6.5.1 Test Setup .....	35
6.5.2 Test Procedure .....	35
6.6 Frequency Stability .....	35
6.6.1 Test Setup .....	35
6.6.2 Test Procedure .....	35
6.7 AC Power Conducted Emissions .....	36



6.7.1	Test Setup .....	36
6.7.2	Test Procedure .....	36
6.8	Unwanted Emissions below 1 GHz .....	37
6.8.1	Test Setup .....	37
6.8.2	Test Procedure .....	38
6.9	Unwanted Emissions above 1 GHz .....	40
6.9.1	Test Setup .....	40
6.9.2	Test Procedure .....	40
<b>7</b>	<b>Test Results of Test Item .....</b>	<b>42</b>
7.1	26 dB Bandwidth .....	42
7.2	RF Output Power .....	58
7.3	Power Spectral Density .....	74
7.4	6 dB Bandwidth .....	89
7.5	Occupied Bandwidth .....	93
7.6	Frequency Stability .....	103
7.7	AC Power Conducted Emissions .....	104
7.8	Unwanted Emissions below 1 GHz .....	108
7.9	Unwanted Emissions above 1 GHz .....	114
<b>8</b>	<b>Pictures of Test Arrangements .....</b>	<b>571</b>
<b>9</b>	<b>Information of the Testing Laboratories .....</b>	<b>572</b>



## Release Control Record

Issue No.	Description	Date Issued
RFBARR-WTW-P23040352I-1	Original release.	2024/4/10

## 1 Certificate

**Product:** 2TX 11be (WiFi7) BW160 + BT/BLE Combo Card

**Brand:** MediaTek

**Test Model:** MT7925B22M

**Sample Status:** Engineering sample

**Applicant:** MediaTek Inc.

**Test Date:** 2023/7/11 ~ 2024/3/16

**Standard:** 47 CFR FCC Part 15, Subpart E (Section 15.407)

**Measurement** ANSI C63.10-2013

**procedure:** KDB 789033 D02 General UNII Test Procedure New Rules v02r01

KDB 662911 D01 Multiple Transmitter Output v02r01

The above equipment has been tested by **Bureau Veritas Consumer Products Services (H.K.) Ltd., Taoyuan Branch**, and found compliance with the requirement of the above standards. The test record, data evaluation & Equipment Under Test (EUT) configurations represented herein are true and accurate accounts of the measurements of the sample's RF characteristics under the conditions specified in this report.

## 2 Summary of Test Results

47 CFR FCC Part 15, Subpart E (Section 15.407)			
Clause	Test Item	Result	Remark
15.407(a)(2)	26 dB Bandwidth	-	For U-NII-2A U-NII-2C Band output power limitation is determined based on 26dBc bandwidth.
15.407(a)(1) 15.407(a)(2) 15.407(a)(3)	RF Output Power	Pass	Meet the requirement of limit.
15.407(a)(1) 15.407(a)(2) 15.407(a)(3)	Power Spectral Density	Pass	Meet the requirement of limit.
15.407(e)	6 dB Bandwidth	Pass	Meet the requirement of limit. (U-NII-3 Band only)
---	Occupied Bandwidth	-	Reference only.
15.407(g)	Frequency Stability	Pass	Meet the requirement of limit.
15.407(b)(9)	AC Power Conducted Emissions	Pass	Minimum passing margin is -10.53 dB at 0.15613 MHz
15.407(b)(9)	Unwanted Emissions below 1 GHz	Pass	Minimum passing margin is -0.7 dB at 300.17 MHz
15.407(b) (1/10) 15.407(b) (2/10) 15.407(b) (3/10) 15.407(b) (4(i)/10)	Unwanted Emissions above 1 GHz	Pass	Minimum passing margin is -0.05 dB at 5458.93 MHz and 5469.00 MHz
15.203	Antenna Requirement	Pass	Antenna connector is i-pex(MHF), R-SMA, RP SMA PLUG, IPEX not a standard connector.

### Notes:

1. Determining compliance based on the results of the compliance measurement, not taking into account measurement instrumentation uncertainty.
2. The "Dynamic Frequency Selection measurement" was recorded in DFS test report.

### 2.1 Measurement Uncertainty

Where relevant, the following measurement uncertainty levels have been estimated for tests performed on the EUT as specified in CISPR 16-4-2:

Measurement	Specification	Expanded Uncertainty (k=2) (±)
26 dB Bandwidth	-	1050.00 Hz
RF Output Power	-	1.1 dB
Power Spectral Density	-	1.3 dB
6 dB Bandwidth	-	1050.00 Hz
Occupied Bandwidth	-	1050.00 Hz
Frequency Stability	-	0.16 ppm
AC Power Conducted Emissions	150 kHz ~ 30 MHz	1.9 dB
Unwanted Emissions below 1 GHz	9 kHz ~ 30 MHz	3.1 dB
	30 MHz ~ 1 GHz	5.5 dB
Unwanted Emissions above 1 GHz	1 GHz ~ 18 GHz	5.1 dB
	18 GHz ~ 40 GHz	5.3 dB

The other instruments specified are routine verified to remain within the calibrated levels, no measurement uncertainty is required to be calculated.

## 2.2 Supplementary Information

There is not any deviation from the test standards for the test method, and no modifications required for compliance.

### 3 General Information

#### 3.1 General Description of EUT

Product	2TX 11be (WiFi7) BW160 + BT/BLE Combo Card
Brand	MediaTek
Test Model	MT7925B22M
Status of EUT	Engineering sample
Power Supply Rating	3.3 Vdc from host equipment
Modulation Type	64QAM, 16QAM, QPSK, BPSK for OFDM 256QAM for OFDM in 11ac mode 1024QAM for OFDMA in 11ax mode 4096QAM for OFDMA in 11be mode
Modulation Technology	OFDM, OFDMA
Transfer Rate	802.11a: up to 54 Mbps 802.11n: up to 300 Mbps 802.11ac: up to 1733.3 Mbps 802.11ax: up to 2401.9 Mbps 802.11be: up to 2882.4 Mbps
Operating Frequency	5.25 GHz ~ 5.32 GHz 5.5 GHz ~ 5.72 GHz
Number of Channel	802.11a, 802.11n (HT20), 802.11ac (VHT20), 802.11ax (HE20), 802.11be (EHT20): 16 802.11n (HT40), 802.11ac (VHT40), 802.11ax (HE40), 802.11be (EHT40): 8 802.11ac (VHT80), 802.11ax (HE80), 802.11be (EHT80): 4 802.11ac (VHT160), 802.11ax (HE160), 802.11be (EHT160): 2
Resource Unit (RU)	Single RU: 26-tone, 52-tone, 106-tone, 242-tone, 484-tone, 996-tone, 2 * 996-tone Multi-RU (Small RU): 52-tone + 26-tone, 106-tone + 26-tone Multi-RU (Large RU): 484-tone + 242-tone, 996-tone + 484-tone, 996-tone + 484-tone + 242-tone
Output Power	<b>1S1T:</b> 5.25 GHz ~ 5.32 GHz : 160.694 mW (22.06 dBm) 5.5 GHz ~ 5.72 GHz : 169.044 mW (22.28 dBm) <b>2S2T:</b> 5.25 GHz ~ 5.32 GHz : 221.112 mW (23.45 dBm) 5.5 GHz ~ 5.72 GHz : 207.227 mW (23.16 dBm)
EUT Category	Client device

Note:

- This report is prepared for FCC class II permissive change. The difference compared with the Report No.: RFBARR-WTW-P23040352-1 as the following:
  - ◆ Enable 802.11be mode of U-NII-2A, U-NII-2C band through software change.
- According to above conditions, for 802.11be mode of U-NII-2A, U-NII-2C band all of test items need to be performed and all data was verified to meet the requirements.
- There are Bluetooth and WLAN (2.4 GHz & 5 GHz & 6 GHz) technology used for the EUT.
- Simultaneously transmission condition.

Condition	Technology	
1	WLAN (2.4 GHz) (1TX)	WLAN (5 GHz) (1TX)
2	WLAN (2.4 GHz) (1TX)	WLAN (5.9 GHz) (1TX)
3	WLAN (2.4 GHz) (1TX)	WLAN (6 GHz) (1TX)
4	WLAN (5 GHz) (1TX)	WLAN (6 GHz) (1TX)
5	WLAN (5 GHz) (2TX)	Bluetooth
6	WLAN (5.9 GHz) (2TX)	Bluetooth
7	WLAN (6GHz) (2TX)	Bluetooth

Note: The emission of the simultaneous operation has been evaluated and no non-compliance was found.



5. The EUT has below Sku numbers, which are identical to each other in all aspects except for the following table:

Sku No	Brand	Model	Different
Sk1	MediaTek	MT7925B22M	DVDDIO 3.3V, power from platform.
Sk2	MediaTek	MT7925B22M	DVDDIO 1.8V, power from IC PMU. (Power Management Unit)

6. The EUT support OFDMA and Partial RU mode, therefore partial RU combination were investigated and the worst case scenario was identified.

7. The EUT support MRU mode is listed as below.

BW	Small size		Large size		
	52+26-tone MRU	106+26-tone MRU	484+242-tone MRU	996+484-tone MRU	996+484+242-tone MRU
20 MHz	v	v	-	-	-
40 MHz	v	v	-	-	-
80 MHz	v	v	v	-	-
160 MHz	v	v	v	v	v

8. The above EUT information is declared by manufacturer and for more detailed features description, please refers to the manufacturer's specifications or user's manual.

### 3.2 Antenna Description of EUT

1. The antenna information is listed as below.

Antenna Set No.	RF Chain No.	Brand	Model	Antenna Net Gain (dBi)	Frequency Range (GHz)	Antenna Type	Connector Type	Cable Length (mm)
1	Chain0	PSA	RFMTA340718EMLB302	3.18 4.92	2.4~2.4835 5.15~5.895	PIFA	i-pex(MHF)	200
	Chain1	PSA	RFMTA340718EMLB302	3.18 4.92	2.4~2.4835 5.15~5.895	PIFA	i-pex(MHF)	200
2	Chain0	PSA	RFMTA311020EMMB301	1.71 4.82 4.76 4.29 4.61 4.09	2.4~2.4835 5.15~5.895 5.925~6.425 6.425~6.525 6.525~6.875 6.875~7.125	PIFA	i-pex(MHF)	200
	Chain1	PSA	RFMTA311020EMMB301	1.71 4.82 4.76 4.29 4.61 4.09	2.4~2.4835 5.15~5.895 5.925~6.425 6.425~6.525 6.525~6.875 6.875~7.125	PIFA	i-pex(MHF)	200
3	Chain0	PSA	RFMTA421230IMMB701	-13.92 -13.91 -13.91 -14.46	5.925~6.425 6.425~6.525 6.525~6.875 6.875~7.125	PIFA	i-pex(MHF)	300
	Chain1	PSA	RFMTA421230IMMB701	-13.92 -13.91 -13.91 -14.46	5.925~6.425 6.425~6.525 6.525~6.875 6.875~7.125	PIFA	i-pex(MHF)	300
4	Chain0	Cortec	AN2450-4902BRS	2.42 3.87	2.4~2.4835 5.15~5.895	Dipole	R-SMA	150
	Chain1	Cortec	AN2450-4902BRS	2.42 3.87	2.4~2.4835 5.15~5.895	Dipole	R-SMA	150
5	Chain0	VSO	JR2Q00340-1	1.62 3.2 3.93 3.61 3.61 3.14	2.4~2.4835 5.15~5.895 5.925~6.425 6.425~6.525 6.525~6.875 6.875~7.125	Dipole	RP SMA PLUG	40
	Chain1	VSO	JR2Q00340-1	1.62 3.2 3.93 3.61 3.61 3.14	2.4~2.4835 5.15~5.895 5.925~6.425 6.425~6.525 6.525~6.875 6.875~7.125	Dipole	RP SMA PLUG	40
6	Chain0	PSA	RFPCA460632IMMB701	-13.2 -13.67 -13.67 -13.09	5.925~6.425 6.425~6.525 6.525~6.875 6.875~7.125	Dipole	IPEX	320
	Chain1	PSA	RFPCA460632IMMB701	-13.2 -13.67 -13.67 -13.09	5.925~6.425 6.425~6.525 6.525~6.875 6.875~7.125	Dipole	IPEX	320

\* Detail antenna specification please refer to antenna datasheet and/or antenna measurement report.

2. The EUT incorporates a MIMO function:

<b>5 GHz Band</b>		
<b>Modulation Mode</b>	<b>TX &amp; RX Configuration</b>	
<b>802.11a</b>	1TX (Diversity) / 2TX	2RX
<b>802.11n (HT20)</b>	1TX (Diversity) / 2TX	2RX
<b>802.11n (HT40)</b>	1TX (Diversity) / 2TX	2RX
<b>802.11ac (VHT20)</b>	1TX (Diversity) / 2TX	2RX
<b>802.11ac (VHT40)</b>	1TX (Diversity) / 2TX	2RX
<b>802.11ac (VHT80)</b>	1TX (Diversity) / 2TX	2RX
<b>802.11ac (VHT160)</b>	1TX (Diversity) / 2TX	2RX
<b>802.11ax (HE20)</b>	1TX (Diversity) / 2TX	2RX
<b>802.11ax (HE40)</b>	1TX (Diversity) / 2TX	2RX
<b>802.11ax (HE80)</b>	1TX (Diversity) / 2TX	2RX
<b>802.11ax (HE160)</b>	1TX (Diversity) / 2TX	2RX
<b>802.11be (EHT20)</b>	1TX (Diversity) / 2TX	2RX
<b>802.11be (EHT40)</b>	1TX (Diversity) / 2TX	2RX
<b>802.11be (EHT80)</b>	1TX (Diversity) / 2TX	2RX
<b>802.11be (EHT160)</b>	1TX (Diversity) / 2TX	2RX
<b>802.11ax (RU26/52/106/242/484/996/996x2)</b>	1TX (Diversity) / 2TX	2RX
<b>802.11be (RU26/52/106/242/484/996/996x2 MRU52+26/106+26/ 484+242/996+484/996+484+242)</b>	1TX (Diversity) / 2TX	2RX

Note: The modulation and bandwidth are similar for 802.11n mode for 20 MHz (40 MHz), 802.11ac mode for 20 MHz (40 MHz, 80 MHz, 160 MHz), 802.11ax mode for 20 MHz (40 MHz, 80 MHz, 160 MHz) and 802.11be mode for 20 MHz (40 MHz, 80 MHz, 160 MHz) therefore the manufacturer will control the power for 802.11n/ac/ax mode is same as the 802.11be mode or more lower than it and investigated worst case to representative mode in test report.

### 3.3 Channel List

#### FOR 5250 ~ 5320 MHz

4 channels are provided for 802.11a, 802.11n (HT20), 802.11ac (VHT20), 802.11ax (HE20), 802.11be (EHT20):

Channel	Frequency	Channel	Frequency
52	5260 MHz	60	5300 MHz
56	5280 MHz	64	5320 MHz

2 channels are provided for 802.11n (HT40), 802.11ac (VHT40), 802.11ax (HE40), 802.11be (EHT40):

Channel	Frequency	Channel	Frequency
54	5270 MHz	62	5310 MHz

1 channel is provided for 802.11ac (VHT80), 802.11ax (HE80), 802.11be (EHT80):

Channel	Frequency
58	5290 MHz

1 straddle channel is provided for 802.11ac (VHT160), 802.11ax (HE160), 802.11be (EHT160):

Channel	Frequency
50	5250 MHz

#### FOR 5500 ~ 5720 MHz

12 channels are provided for 802.11a, 802.11n (HT20), 802.11ac (VHT20), 802.11ax (HE20), 802.11be (EHT20):

Channel	Frequency	Channel	Frequency
100	5500 MHz	124	5620 MHz
104	5520 MHz	128	5640 MHz
108	5540 MHz	132	5660 MHz
112	5560 MHz	136	5680 MHz
116	5580 MHz	140	5700 MHz
120	5600 MHz	144	5720 MHz

6 channels are provided for 802.11n (HT40), 802.11ac (VHT40), 802.11ax (HE40), 802.11be (EHT40):

Channel	Frequency	Channel	Frequency
102	5510 MHz	126	5630 MHz
110	5550 MHz	134	5670 MHz
118	5590 MHz	142	5710 MHz

3 channels are provided for 802.11ac (VHT80), 802.11ax (HE80), 802.11be (EHT80):

Channel	Frequency	Channel	Frequency
106	5530 MHz	138	5690 MHz
122	5610 MHz		

1 channel is provided for 802.11ac (VHT160), 802.11ax (HE160), 802.11be (EHT160):

Channel	Frequency
114	5570 MHz

### 3.4 Test Mode Applicability and Tested Channel Detail

Pre-Scan:	<ol style="list-style-type: none"> <li>The EUT has the following Sku numbers: Sku1/ Sku2. Pre-scan the worst case as a representative test condition.</li> <li>For 1Tx diversity configuration, Pre-scan in these chain 0 and chain 1 and find the worst case as a representative test condition.</li> <li>The worst-case Partial RU modes across all supported bandwidth modes has been determined via pre-scan.</li> <li>Pre-Scan has been conducted to determine the worst-case mode from all possible combinations between available modulations, data rates and antenna ports (if EUT with antenna diversity architecture).</li> </ol>
Worst Case:	<ol style="list-style-type: none"> <li>EUT Worst Condition: Sku1</li> <li>For 1Tx diversity configuration the worst chain is: Chain 0</li> <li>The worst case occurs in 20 MHz bandwidth (RU 26/52/106).</li> </ol>

Following channel(s) was (were) selected for the final test as listed below:

Test Item	EUT Configure Mode	Mode	Signal Mode	Tested Channel	Modulation	Data Rate Parameter	RU/MRU Index
26 dB Bandwidth	A	802.11be (EHT20)	1S1T / 2S2T	52, 60, 64, 100, 116, 140, 144	BPSK	MCS0	NA
		802.11be (EHT40)	1S1T / 2S2T	54, 62, 102, 110, 134, 142	BPSK	MCS0	NA
		802.11be (EHT80)	1S1T / 2S2T	58, 106, 122, 138	BPSK	MCS0	NA
		802.11be (EHT160)	1S1T / 2S2T	50, 114	BPSK	MCS0	NA
		802.11be (EHT20) 26-tone RU	1S1T / 2S2T	64, 100, 140	BPSK	MCS0	8, 0, 8
		802.11be (EHT20) 52-tone RU	1S1T / 2S2T	64, 100, 140	BPSK	MCS0	40, 37, 40
		802.11be (EHT20) 106-tone RU	1S1T / 2S2T	64, 100, 140	BPSK	MCS0	54, 53, 54
		802.11be (EHT20) 52+26-tone MRU	1S1T / 2S2T	64, 100, 140	BPSK	MCS0	72, 70, 72
		802.11be (EHT20) 106+26-tone MRU	1S1T / 2S2T	64, 100, 140	BPSK	MCS0	83, 82, 83
		802.11be (EHT80) 484+242-tone MRU	1S1T / 2S2T	58, 106, 138	BPSK	MCS0	91, 92, 91
		802.11be (EHT160) 996+484-tone MRU	1S1T / 2S2T	50, 114	BPSK	MCS0	95-1, 94-1
		802.11be (EHT160) 996+484+242-tone MRU	1S1T / 2S2T	50, 114	BPSK	MCS0	99-1, 97-1

Test Item	EUT Configure Mode	Mode	Signal Mode	Tested Channel	Modulation	Data Rate Parameter	RU/MRU Index
RF Output Power	A	802.11be (EHT20)	1S1T / 2S2T	52, 60, 64, 100, 116, 140, 144	BPSK	MCS0	NA
		802.11be (EHT40)	1S1T / 2S2T	54, 62, 102, 110, 134, 142	BPSK	MCS0	NA
		802.11be (EHT80)	1S1T / 2S2T	58, 106, 122, 138	BPSK	MCS0	NA
		802.11be (EHT160)	1S1T / 2S2T	50, 114	BPSK	MCS0	NA
		802.11be (EHT20) 26-tone RU	1S1T / 2S2T	64, 100, 140	BPSK	MCS0	8, 0, 8
		802.11be (EHT20) 52-tone RU	1S1T / 2S2T	64, 100, 140	BPSK	MCS0	40, 37, 40
		802.11be (EHT20) 106-tone RU	1S1T / 2S2T	64, 100, 140	BPSK	MCS0	54, 53, 54
		802.11be (EHT20) 52+26-tone MRU	1S1T / 2S2T	64, 100, 140	BPSK	MCS0	72, 70, 72
		802.11be (EHT20) 106+26-tone MRU	1S1T / 2S2T	64, 100, 140	BPSK	MCS0	83, 82, 83
		802.11be (EHT80) 484+242-tone MRU	1S1T / 2S2T	58, 106, 138	BPSK	MCS0	91, 92, 91
		802.11be (EHT160) 996+484-tone MRU	1S1T / 2S2T	50, 114	BPSK	MCS0	95-1, 94-1
		802.11be (EHT160) 996+484+242-tone MRU	1S1T / 2S2T	50, 114	BPSK	MCS0	99-1, 97-1

Test Item	EUT Configure Mode	Mode	Signal Mode	Tested Channel	Modulation	Data Rate Parameter	RU/MRU Index
Power Spectral Density	A	802.11be (EHT20)	1S1T / 2S2T	52, 60, 64, 100, 116, 140, 144	BPSK	MCS0	NA
		802.11be (EHT40)	1S1T / 2S2T	54, 62, 102, 110, 134, 142	BPSK	MCS0	NA
		802.11be (EHT80)	1S1T / 2S2T	58, 106, 122, 138	BPSK	MCS0	NA
		802.11be (EHT160)	1S1T / 2S2T	50, 114	BPSK	MCS0	NA
		802.11be (EHT20) 26-tone RU	1S1T / 2S2T	64, 100, 140	BPSK	MCS0	8, 0, 8
		802.11be (EHT20) 52-tone RU	1S1T / 2S2T	64, 100, 140	BPSK	MCS0	40, 37, 40
		802.11be (EHT20) 106-tone RU	1S1T / 2S2T	64, 100, 140	BPSK	MCS0	54, 53, 54
		802.11be (EHT20) 52+26-tone MRU	1S1T / 2S2T	64, 100, 140	BPSK	MCS0	72, 70, 72
		802.11be (EHT20) 106+26-tone MRU	1S1T / 2S2T	64, 100, 140	BPSK	MCS0	83, 82, 83
		802.11be (EHT80) 484+242-tone MRU	1S1T / 2S2T	58, 106, 138	BPSK	MCS0	91, 92, 91
		802.11be (EHT160) 996+484-tone MRU	1S1T / 2S2T	50, 114	BPSK	MCS0	95-1, 94-1
		802.11be (EHT160) 996+484+242-tone MRU	1S1T / 2S2T	50, 114	BPSK	MCS0	99-1, 97-1
		6 dB Bandwidth	A	802.11be (EHT20)	1S1T / 2S2T	144	BPSK
802.11be (EHT40)	1S1T / 2S2T			142	BPSK	MCS0	NA
802.11be (EHT80)	1S1T / 2S2T			138	BPSK	MCS0	NA

Test Item	EUT Configure Mode	Mode	Signal Mode	Tested Channel	Modulation	Data Rate Parameter	RU/MRU Index
Occupied Bandwidth	A	802.11be (EHT20)	1S1T / 2S2T	52, 60, 64, 100, 116, 140, 144	BPSK	MCS0	NA
		802.11be (EHT40)	1S1T / 2S2T	54, 62, 102, 110, 134, 142	BPSK	MCS0	NA
		802.11be (EHT80)	1S1T / 2S2T	58, 106, 122, 138	BPSK	MCS0	NA
		802.11be (EHT160)	1S1T / 2S2T	50, 114	BPSK	MCS0	NA
		802.11be (EHT20) 26-tone RU	1S1T / 2S2T	64, 100, 140	BPSK	MCS0	8, 0, 8
		802.11be (EHT20) 52-tone RU	1S1T / 2S2T	64, 100, 140	BPSK	MCS0	40, 37, 40
		802.11be (EHT20) 106-tone RU	1S1T / 2S2T	64, 100, 140	BPSK	MCS0	54, 53, 54
		802.11be (EHT20) 52+26-tone MRU	1S1T / 2S2T	64, 100, 140	BPSK	MCS0	72, 70, 72
		802.11be (EHT20) 106+26-tone MRU	1S1T / 2S2T	64, 100, 140	BPSK	MCS0	83, 82, 83
		802.11be (EHT80) 484+242-tone MRU	1S1T / 2S2T	58, 106, 138	BPSK	MCS0	91, 92, 91
		802.11be (EHT160) 996+484-tone MRU	1S1T / 2S2T	50, 114	BPSK	MCS0	95-1, 94-1
		802.11be (EHT160) 996+484+242-tone MRU	1S1T / 2S2T	50, 114	BPSK	MCS0	99-1, 97-1
		Frequency Stability	A	-	-	100	unmodulated
AC Power Conducted Emissions	C	802.11be (EHT40)	1S1T	110	BPSK	MCS0	NA
			2S2T	54	BPSK	MCS0	NA
Unwanted Emissions below 1 GHz	A, B	802.11be (EHT40)	1S1T	110	BPSK	MCS0	NA
			2S2T	54	BPSK	MCS0	NA



Test Item	EUT Configure Mode	Mode	Signal Mode	Tested Channel	Modulation	Data Rate Parameter	RU/MRU Index
Unwanted Emissions above 1 GHz	A, B	802.11be (EHT20)	1S1T / 2S2T	52, 60, 64, 100, 116, 140, 144	BPSK	MCS0	NA
		802.11be (EHT40)	1S1T / 2S2T	54, 62, 102, 110, 134, 142	BPSK	MCS0	NA
		802.11be (EHT80)	1S1T / 2S2T	58, 106, 122, 138	BPSK	MCS0	NA
		802.11be (EHT160)	1S1T / 2S2T	50, 114	BPSK	MCS0	NA
		802.11be (EHT20) 26-tone RU	1S1T / 2S2T	64, 100, 140	BPSK	MCS0	8, 0, 8
		802.11be (EHT20) 52-tone RU	1S1T / 2S2T	64, 100, 140	BPSK	MCS0	40, 37, 40
		802.11be (EHT20) 106-tone RU	1S1T / 2S2T	64, 100, 140	BPSK	MCS0	54, 53, 54
		802.11be (EHT20) 52+26-tone MRU	1S1T / 2S2T	64, 100, 140	BPSK	MCS0	72, 70, 72
		802.11be (EHT20) 106+26-tone MRU	1S1T / 2S2T	64, 100, 140	BPSK	MCS0	83, 82, 83
		802.11be (EHT80) 484+242-tone MRU	1S1T / 2S2T	58, 106, 138	BPSK	MCS0	91, 92, 91
		802.11be (EHT160) 996+484-tone MRU	1S1T / 2S2T	50, 114	BPSK	MCS0	95-1, 94-1
		802.11be (EHT160) 996+484+242-tone MRU	1S1T / 2S2T	50, 114	BPSK	MCS0	99-1, 97-1
		EUT Configure Mode:	A	EUT only (remove 50 ohm terminator and Connect to the appropriate equipment)			
B	EUT with 50 ohm terminator						
C	EUT with antenna						
Note: Channel puncturing mechanism is not supported.							

### 3.5 Duty Cycle of Test Signal

#### For 1S1T

##### 802.11be (EHT20):

Duty cycle = 3.945 ms / 5.214 ms x 100% = 75.7%, duty factor = 10 \* log (1/Duty cycle) = 1.21 dB

##### 802.11be (EHT40):

Duty cycle = 3.952 ms / 5.241 ms x 100% = 75.4%, duty factor = 10 \* log (1/Duty cycle) = 1.23 dB

##### 802.11be (EHT80):

Duty cycle = 1.93 ms / 2.606 ms x 100% = 74.1%, duty factor = 10 \* log (1/Duty cycle) = 1.30 dB

##### 802.11be (EHT160):

Duty cycle = 1.759 ms / 2.276 ms x 100% = 77.3%, duty factor = 10 \* log (1/Duty cycle) = 1.12 dB

##### 802.11be (EHT20) 26-tone RU:

Duty cycle = 1.521 ms / 1.638 ms x 100% = 92.9%, duty factor = 10 \* log (1/Duty cycle) = 0.32 dB

##### 802.11be (EHT20) 52-tone RU:

Duty cycle = 1.521 ms / 1.638 ms x 100% = 92.9%, duty factor = 10 \* log (1/Duty cycle) = 0.32 dB

##### 802.11be (EHT20) 106-tone RU:

Duty cycle = 1.396 ms / 1.506 ms x 100% = 92.7%, duty factor = 10 \* log (1/Duty cycle) = 0.33 dB

##### 802.11be (EHT20) 52+26-tone MRU:

Duty cycle = 1.601 ms / 1.738 ms x 100% = 92.1%, duty factor = 10 \* log (1/Duty cycle) = 0.36 dB

##### 802.11be (EHT20) 106+26-tone MRU:

Duty cycle = 1.601 ms / 1.738 ms x 100% = 92.1%, duty factor = 10 \* log (1/Duty cycle) = 0.36 dB

##### 802.11be (EHT80) 484+242-tone MRU:

Duty cycle = 1.197 ms / 1.307 ms x 100% = 91.6%, duty factor = 10 \* log (1/Duty cycle) = 0.38 dB

##### 802.11be (EHT160) 996+484-tone MRU:

Duty cycle = 1.163 ms / 1.28 ms x 100% = 90.9%, duty factor = 10 \* log (1/Duty cycle) = 0.42 dB

##### 802.11be (EHT160) 996+484+242-tone MRU:

Duty cycle = 1.163 ms / 1.28 ms x 100% = 90.9%, duty factor = 10 \* log (1/Duty cycle) = 0.42 dB



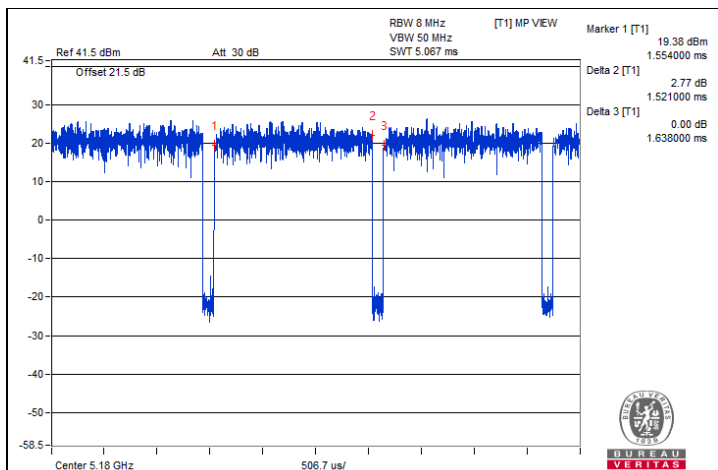

802.11be (EHT20) 26-tone RU

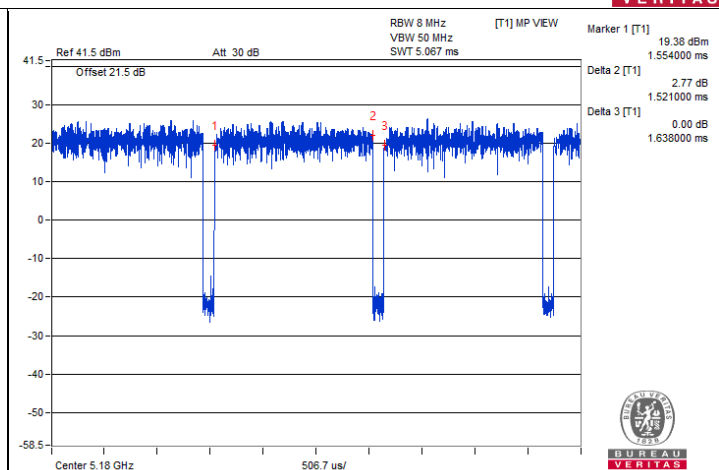

802.11be (EHT20) 52-tone RU

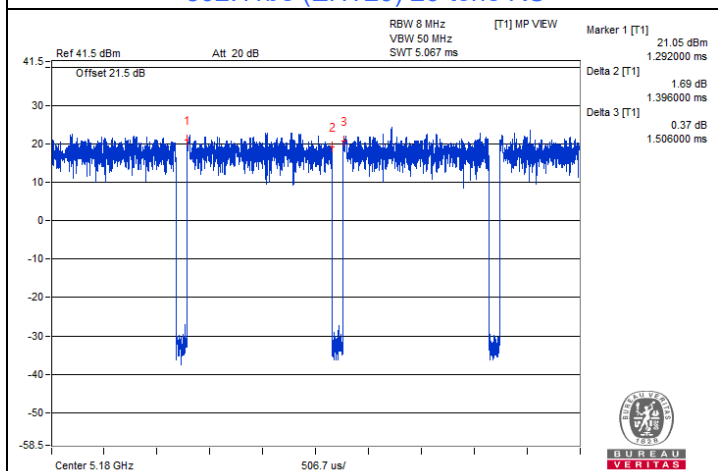

802.11be (EHT20) 106-tone RU

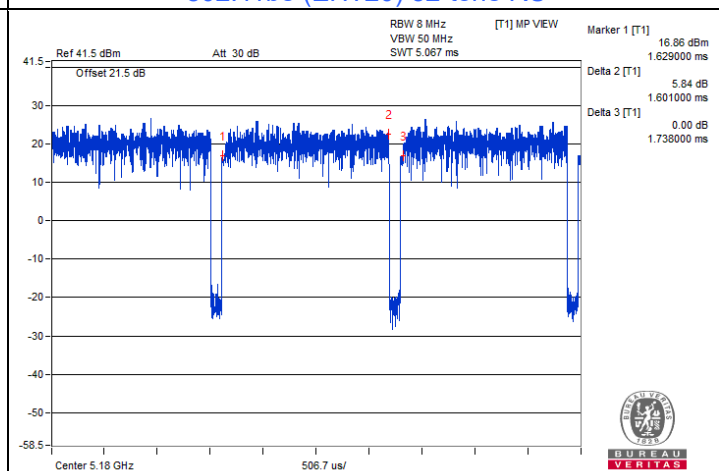

802.11be (EHT20) 52+26-tone MRU

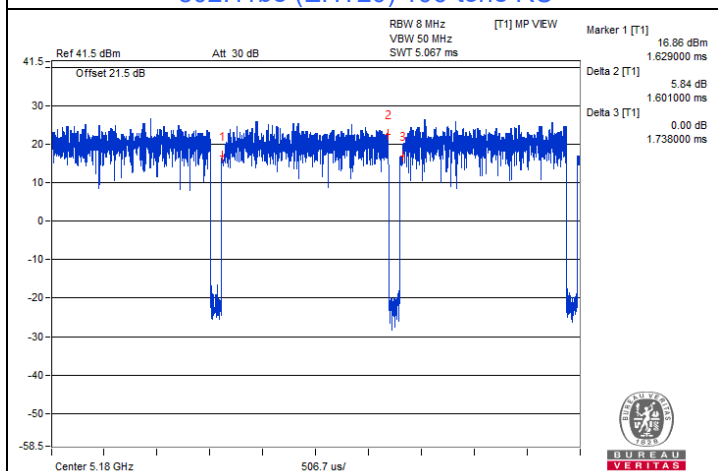

802.11be (EHT20) 106+26-tone MRU

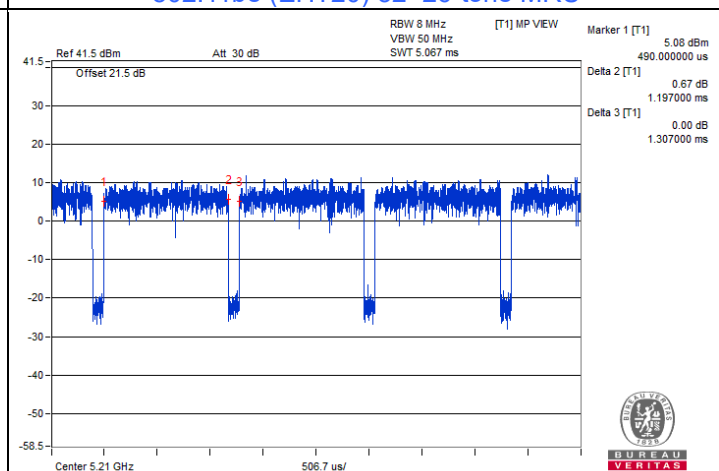

802.11be (EHT80) 484+242-tone MRU

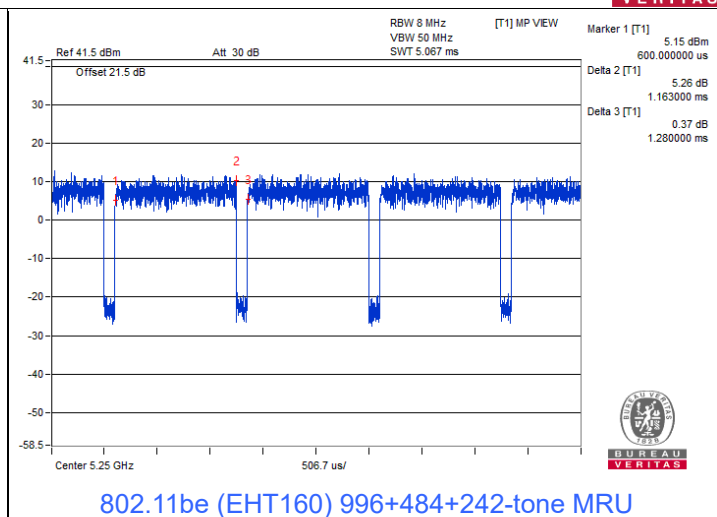
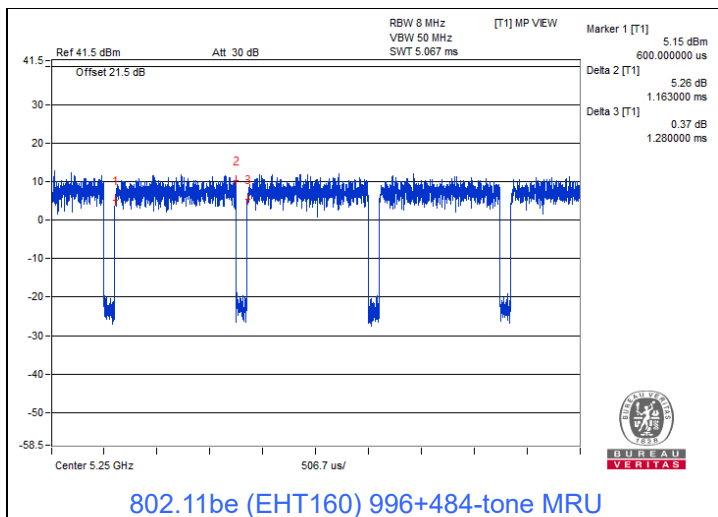

**For 2S2T**

**802.11be (EHT20):**

Duty cycle = 2.014 ms / 3.287 ms x 100% = 61.3%, duty factor =  $10 * \log (1/\text{Duty cycle}) = 2.13 \text{ dB}$

**802.11be (EHT40):**

Duty cycle = 2.014 ms / 3.299 ms x 100% = 61.0%, duty factor =  $10 * \log (1/\text{Duty cycle}) = 2.14 \text{ dB}$

**802.11be (EHT80):**

Duty cycle = 1.01 ms / 1.702 ms x 100% = 59.3%, duty factor =  $10 * \log (1/\text{Duty cycle}) = 2.27 \text{ dB}$

**802.11be (EHT160):**

Duty cycle = 0.935 ms / 1.434 ms x 100% = 65.2%, duty factor =  $10 * \log (1/\text{Duty cycle}) = 1.86 \text{ dB}$

**802.11be (EHT20) 26-tone RU:**

Duty cycle = 0.853 ms / 0.962 ms x 100% = 88.7%, duty factor =  $10 * \log (1/\text{Duty cycle}) = 0.52 \text{ dB}$

**802.11be (EHT20) 52-tone RU:**

Duty cycle = 0.853 ms / 0.962 ms x 100% = 88.7%, duty factor =  $10 * \log (1/\text{Duty cycle}) = 0.52 \text{ dB}$

**802.11be (EHT20) 106-tone RU:**

Duty cycle = 0.853 ms / 0.962 ms x 100% = 88.7%, duty factor =  $10 * \log (1/\text{Duty cycle}) = 0.52 \text{ dB}$

**802.11be (EHT20) 52+26-tone MRU:**

Duty cycle = 0.853 ms / 0.962 ms x 100% = 88.7%, duty factor =  $10 * \log (1/\text{Duty cycle}) = 0.52 \text{ dB}$

**802.11be (EHT20) 106+26-tone MRU:**

Duty cycle = 0.882 ms / 1.008 ms x 100% = 87.5%, duty factor =  $10 * \log (1/\text{Duty cycle}) = 0.58 \text{ dB}$

**802.11be (EHT80) 484+242-tone MRU:**

Duty cycle = 0.649 ms / 0.757 ms x 100% = 85.7%, duty factor =  $10 * \log (1/\text{Duty cycle}) = 0.67 \text{ dB}$

**802.11be (EHT160) 996+484-tone MRU:**

Duty cycle = 0.634 ms / 0.742 ms x 100% = 85.4%, duty factor =  $10 * \log (1/\text{Duty cycle}) = 0.68 \text{ dB}$

**802.11be (EHT160) 996+484+242-tone MRU:**

Duty cycle = 0.634 ms / 0.742 ms x 100% = 85.4%, duty factor =  $10 * \log (1/\text{Duty cycle}) = 0.68 \text{ dB}$



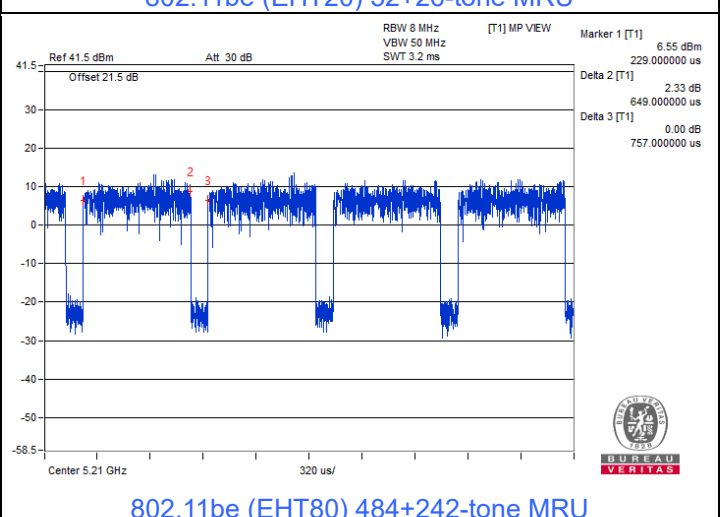
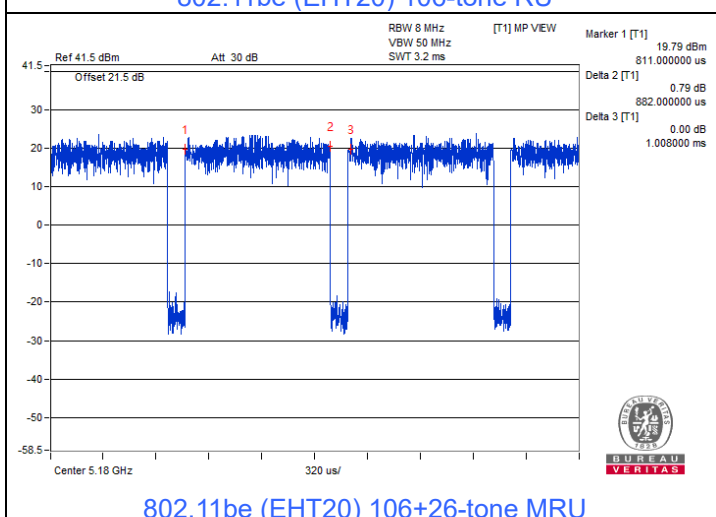
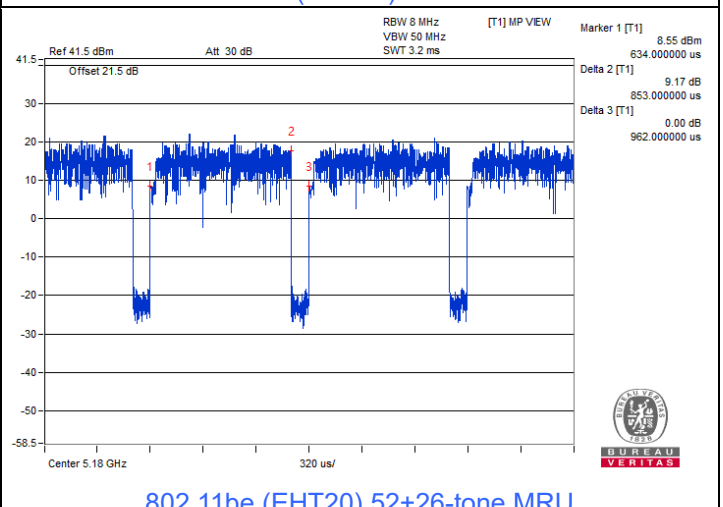
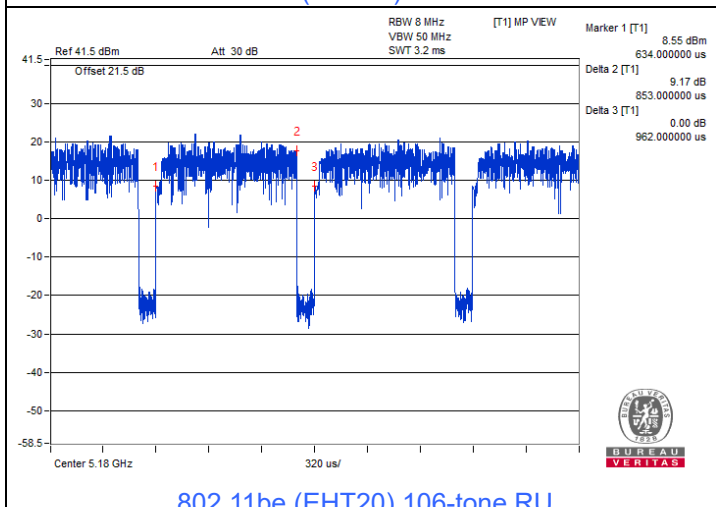
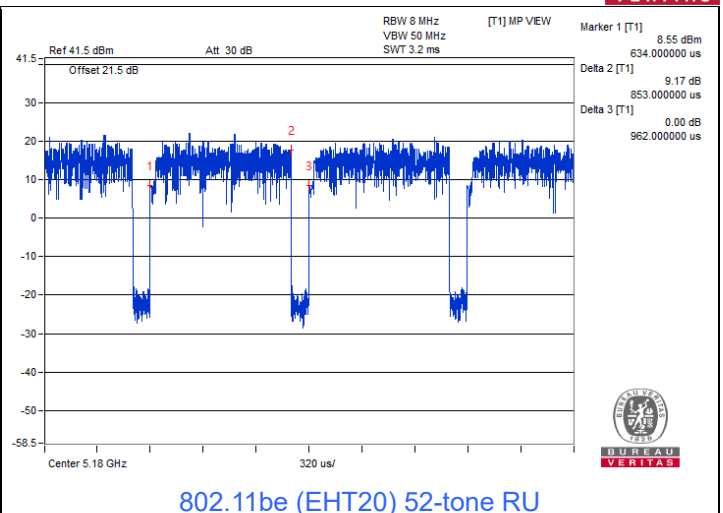
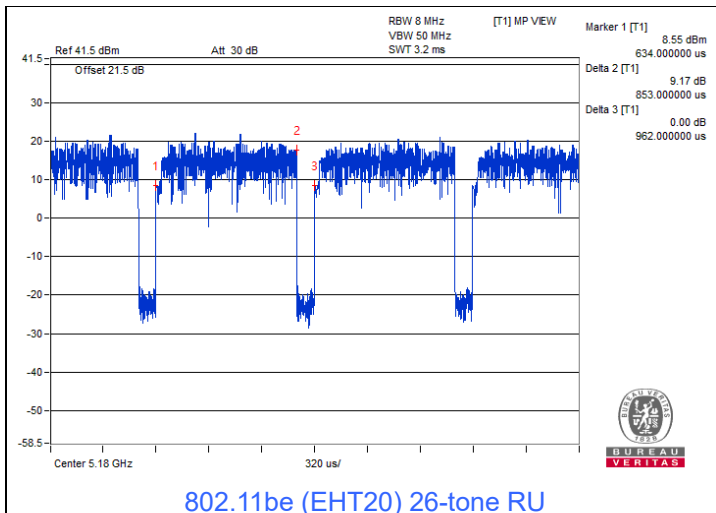



BUREAU  
VERITAS

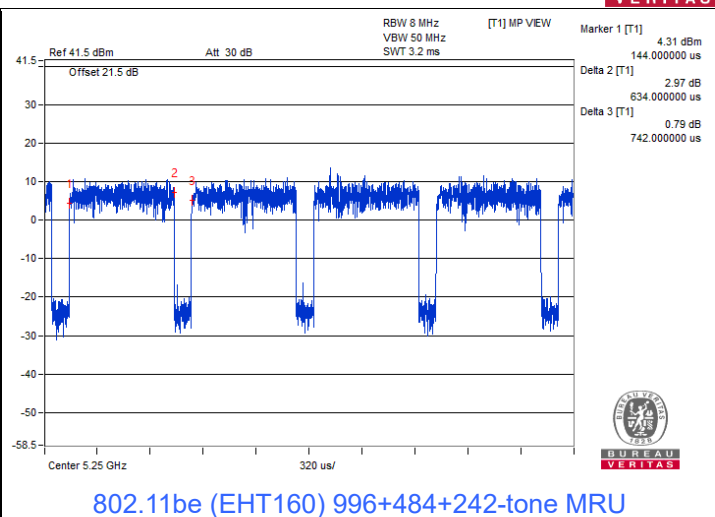
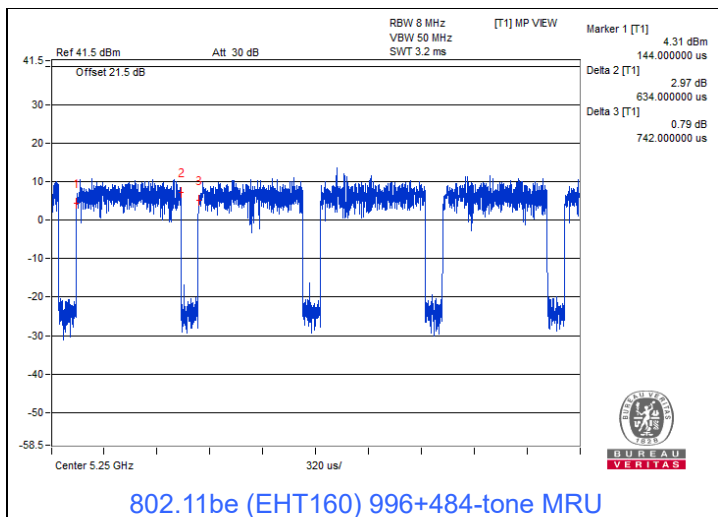

### 3.6 Test Program Used and Operation Descriptions

Controlling software (QAtool\_V06 (0.0.2.100)) has been activated to set the EUT under transmission condition continuously at specific channel frequency.

### 3.7 Connection Diagram of EUT and Peripheral Devices

#### For AC Power Conducted Emission test

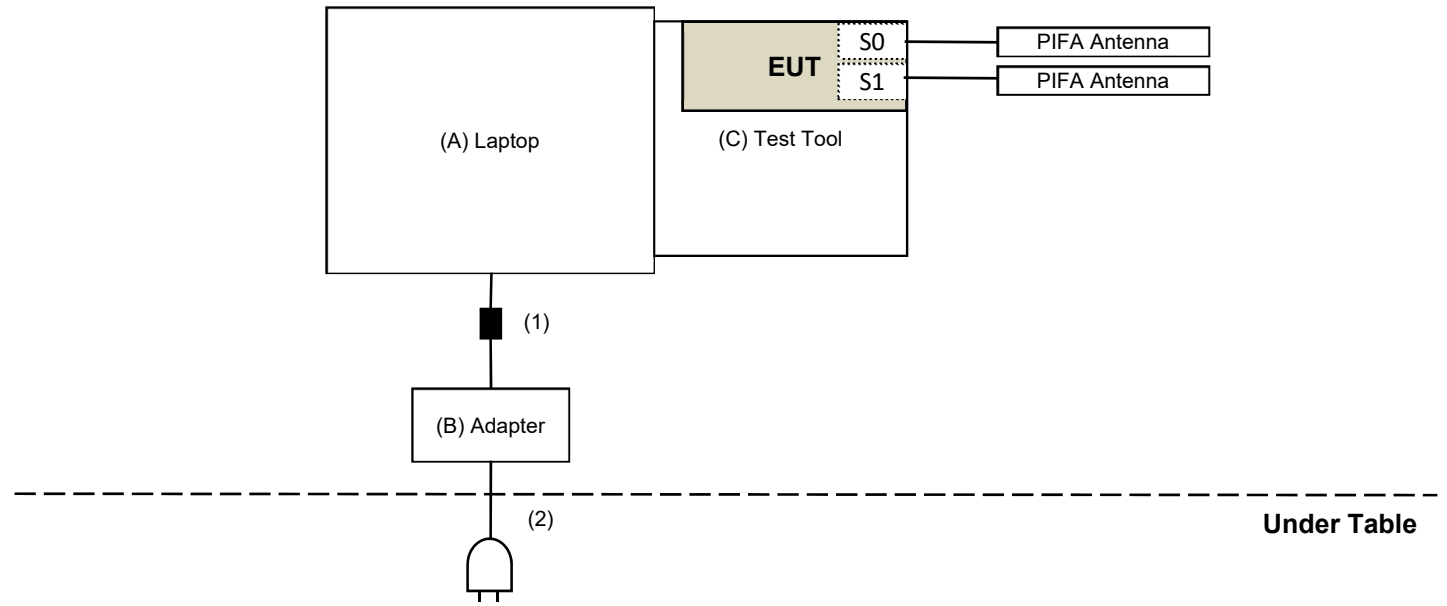

#### For Unwanted Emission test

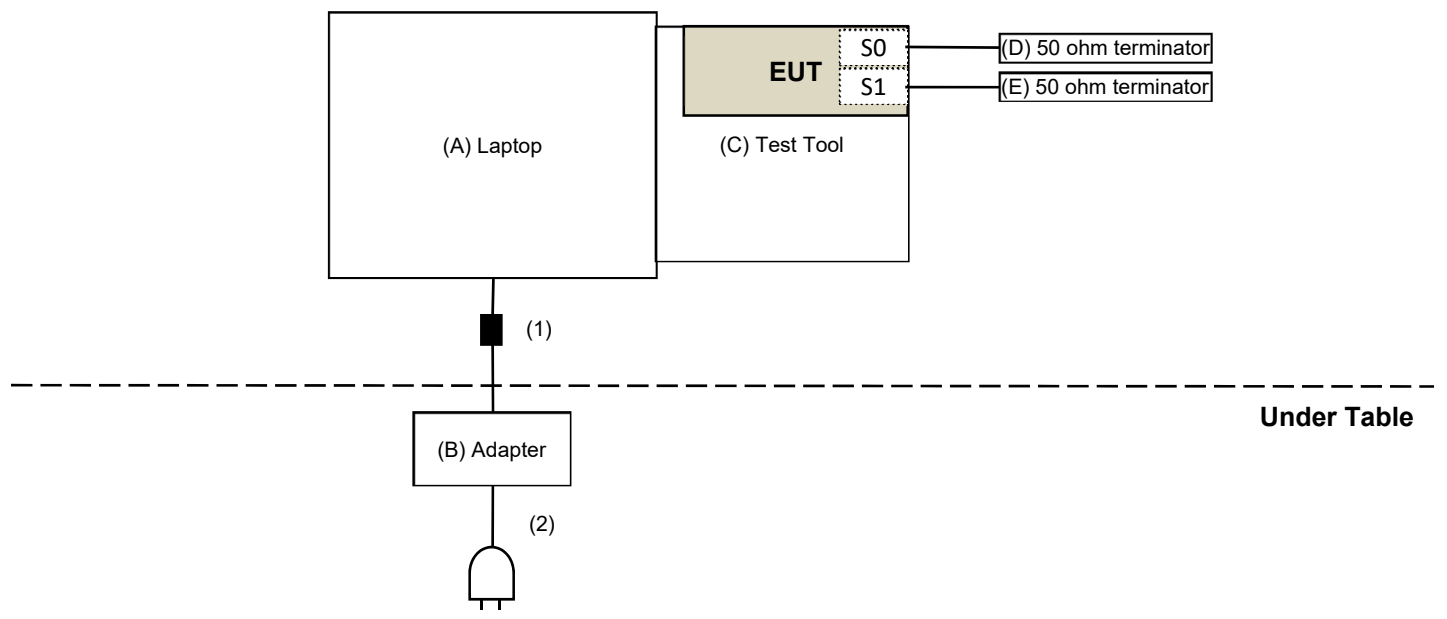



### 3.8 Configuration of Peripheral Devices and Cable Connections

ID	Product	Brand	Model No.	Serial No.	FCC ID	Remarks
A	Laptop	DELL	E5430	HYV4VY1	DoC	Provided by Lab
B	Adapter	DELL	LLA65NS2-01	N/A	N/A	Provided by Lab
C	Test Tool	Mediatek	MTK1849	N/A	N/A	Supplied by applicant
D	50 Ohm terminator	WOKEN	WTER-18S2	N/A	N/A	Provided by Lab
E	50 Ohm terminator	WOKEN	WTER-18S2	N/A	N/A	Provided by Lab

ID	Cable Descriptions	Qty.	Length (m)	Shielding (Yes/No)	Cores (Qty.)	Remarks
1	DC Cable	1	1.8	No	1	Provided by Lab
2	AC Cable	1	1	No	0	Provided by Lab

## 4 Test Instruments

The calibration interval of the all test instruments are 12 months and the calibrations are traceable to NML/ROC and NIST/USA.

### 4.1 26 dB Bandwidth

Description Manufacturer	Model No.	Serial No.	Calibrated Date	Calibrated Until
MXA Signal Analyzer Keysight	N9020B	MY60112409	2023/2/18	2024/2/17
Software	ADT_RF Test Software V7.6.5.4	N/A	N/A	N/A

Notes:

1. The test was performed in Oven room 2.
2. Tested Date: 2023/7/11 ~ 2023/7/13

### 4.2 RF Output Power

Description Manufacturer	Model No.	Serial No.	Calibrated Date	Calibrated Until
MXA Signal Analyzer Keysight	N9020B	MY60112409	2023/2/18	2024/2/17
Pulse Power Sensor Anritsu	MA2411B	1726434	2023/6/19	2024/6/18
RF Power Meter Anritsu	ML2495A	1529002	2023/6/17	2024/6/16
Software	ADT_RF Test Software V7.6.5.4	N/A	N/A	N/A

Notes:

1. The test was performed in Oven room 2.
2. Tested Date: 2023/7/11 ~ 2023/7/13

### 4.3 Power Spectral Density

Refer to section 4.1 to get information of the instruments.

### 4.4 6 dB Bandwidth

Refer to section 4.1 to get information of the instruments.

### 4.5 Occupied Bandwidth

Refer to section 4.1 to get information of the instruments.

#### 4.6 Frequency Stability

Description Manufacturer	Model No.	Serial No.	Calibrated Date	Calibrated Until
DC Power Supply Topward	6603D	795558	N/A	N/A
MXA Signal Analyzer Keysight	N9020B	MY60112409	2023/2/18	2024/2/17
Software	ADT_RF Test Software V7.6.5.4	N/A	N/A	N/A
Temperature & Humidity Chamber Giant Force	GTH-150-40-SP-AR	MAA0812-008	2022/12/26	2023/12/25
True RMS Clamp Meter FLUKE	325	31130711WS	2023/6/8	2024/6/7

Notes:

1. The test was performed in Oven room 2.
2. Tested Date: 2023/7/11

#### 4.7 AC Power Conducted Emissions

Description Manufacturer	Model No.	Serial No.	Calibrated Date	Calibrated Until
50 ohm terminal resistance Telegartner	50 ohm	3	2023/10/20	2024/10/19
EMI Test Receiver R&S	ESCS 30	847124/029	2023/10/18	2024/10/17
Fixed Attenuator STI	STI02-2200-10	005	2024/2/19	2025/2/18
LISN R&S	ESH3-Z5	835239/001	2023/4/6	2024/4/5
		848773/004	2023/10/13	2024/10/12
RF Coaxial Cable JYEBAO	5D-FB	COCCAB-001	2024/2/19	2025/2/18
Software BVADT	BVADT_Cond_V7.3.7.4	N/A	N/A	N/A

Notes:

1. The test was performed in Conduction 1
2. Tested Date: 2024/3/12 ~ 2024/3/16

#### 4.8 Unwanted Emissions below 1 GHz

##### Mode A

Description Manufacturer	Model No.	Serial No.	Calibrated Date	Calibrated Until
MXA Signal Analyzer Keysight	N9020B	MY60112409	2024/2/20	2025/2/19
Software	ADT_RF Test Software V7.6.5.4	N/A	N/A	N/A

Notes:

1. The test was performed in Oven room 2.
2. Tested Date: 2024/3/15

##### Mode B

Description Manufacturer	Model No.	Serial No.	Calibrated Date	Calibrated Until
Bi_Log Antenna Schwarzbeck	VULB 9168	9168-406	2023/10/13	2024/10/12
Boresight Antenna Tower & Turn Table Max-Full	MF-7802BS	MF780208530	N/A	N/A
Fixed Attenuator Mini-Circuits	UNAT-5+	PAD-ATT5-03	2024/2/17	2025/2/16
Loop Antenna Electro-Metrics	EM-6879	264	2024/2/23	2025/2/22
MXA Signal Analyzer Keysight	N9020B	MY60112408	2024/3/7	2025/3/6
MXE EMI Receiver Keysight	N9038A	MY59050100	2023/6/13	2024/6/12
Preamplifier EMCI	EMC330N	980701	2024/2/17	2025/2/16
	EMC001340	980142	2024/2/19	2025/2/18
RF Coaxial Cable JYEBAO	5D-FB	LOOPCAB-002	2024/2/19	2025/2/18
		LOOPCAB-001	2024/2/19	2025/2/18
RF Coaxial Cable mTJ	100100-CFD400LW-800	CFD400-800	2024/2/17	2025/2/16
	100100-CFD400LW-400	CFD400-400	2024/2/17	2025/2/16
	100100-CFD400LW-200	CFD400-200	2024/2/17	2025/2/16
Software	ADT_Radiated_V8.7.08	N/A	N/A	N/A

Notes:

1. The test was performed in 966 Chamber No. 4.
2. Tested Date: 2024/3/12 ~ 2024/3/16

#### 4.9 Unwanted Emissions above 1 GHz

##### Mode A

Description Manufacturer	Model No.	Serial No.	Calibrated Date	Calibrated Until
MXA Signal Analyzer Keysight	N9020B	MY60112409	2023/2/18	2024/2/17
Software	ADT_RF Test Software V7.6.5.4	N/A	N/A	N/A

Notes:

1. The test was performed in Oven room 2.
2. Tested Date: 2023/7/18

##### Mode B

Description Manufacturer	Model No.	Serial No.	Calibrated Date	Calibrated Until
Boresight Antenna Tower & Turn Table Max-Full	MF-7802BS	MF780208530	N/A	N/A
Horn Antenna Schwarzbeck	BBHA 9120D	9120D-783	2022/11/13	2023/11/12
	BBHA 9170	9170-739	2022/11/13	2023/11/12
MXA Signal Analyzer Keysight	N9020B	MY60112408	2023/3/6	2024/3/5
Preamplifier EMCI	EMC12630SE	980688	2022/10/4	2023/10/3
	EMC184045SE	980387	2022/12/28	2023/12/27
RF Coaxial Cable EMCI	EMC102-KM-KM-4000	200214	2023/2/20	2024/2/19
	EMC102-KM-KM-1200	160924	2022/12/28	2023/12/27
	EMC104-SM-SM-6000	210704	2022/11/4	2023/11/3
	EMC104-SM-SM-2000	180502	2023/3/27	2024/3/26
	EMC104-SM-SM-1200	160922	2022/12/15	2023/12/14
Software	ADT_Radiated_V8.7.08	N/A	N/A	N/A

Notes:

1. The test was performed in 966 Chamber No. 4.
2. Tested Date: 2023/7/11

## 5 Limits of Test Items

### 5.1 26 dB Bandwidth

The results are for reference only.

### 5.2 RF Output Power

Operation Band	EUT Category	Limit
U-NII-1	Outdoor Access Point	1 Watt (30 dBm) (Max. e.i.r.p $\leq$ 125mW(21 dBm) at any elevation angle above 30 degrees as measured from the horizon)
	Fixed point-to-point Access Point	1 Watt (30 dBm)
	Indoor Access Point	1 Watt (30 dBm)
	Mobile and Portable client device	250mW (24 dBm)

Operation Band	Limit
U-NII-2A	250 mW (24 dBm) or 11 dBm+10 log B*
U-NII-2C	250 mW (24 dBm) or 11 dBm+10 log B*
U-NII-3	1 Watt (30 dBm)

\*B is the 26 dB emission bandwidth in megahertz

Per KDB 662911 D01 Multiple Transmitter Output Method of conducted output power measurement on IEEE 802.11 devices,

Array Gain = 0 dB (i.e., no array gain) for  $N_{ANT} \leq 4$ ;

Array Gain = 0 dB (i.e., no array gain) for channel widths  $\geq 40$  MHz for any  $N_{ANT}$ ;

Array Gain = 5 log( $N_{ANT}/N_{SS}$ ) dB or 3 dB, whichever is less, for 20-MHz channel widths with  $N_{ANT} \geq 5$ .

For power measurements on all other devices: Array Gain = 10 log( $N_{ANT}/N_{SS}$ ) dB.

### 5.3 Power Spectral Density

Operation Band	EUT Category	Limit
U-NII-1	Outdoor Access Point	17 dBm/MHz
	Fixed point-to-point Access Point	
	Indoor Access Point	
	Mobile and Portable client device	11 dBm/MHz

Operation Band	Limit
U-NII-2A	11 dBm/MHz
U-NII-2C	11 dBm/MHz
U-NII-3	30 dBm/500 kHz

### 5.4 6 dB Bandwidth

Within the 5.725-5.850 GHz band, the minimum 6 dB bandwidth of U-NII devices shall be at least 500 kHz.

## 5.5 Occupied Bandwidth

The results are for reference only.

## 5.6 Frequency Stability

The frequency of the carrier signal shall be maintained within band of operation.

## 5.7 AC Power Conducted Emissions

Frequency (MHz)	Conducted Limit (dBuV)	
	Quasi-peak	Average
0.15 - 0.5	66 - 56	56 - 46
0.50 - 5.0	56	46
5.0 - 30.0	60	50

Notes:

1. The lower limit shall apply at the transition frequencies.
2. The limit decreases in line with the logarithm of the frequency in the range of 0.15 to 0.50 MHz.

## 5.8 Unwanted Emissions below 1 GHz

Radiated emissions which fall in the restricted bands must comply with the radiated emission limits specified as below table.

Frequencies (MHz)	Field Strength (microvolts/meter)	Measurement Distance (meters)
0.009 ~ 0.490	2400/F(kHz)	300
0.490 ~ 1.705	24000/F(kHz)	30
1.705 ~ 30.0	30	30
30 ~ 88	100	3
88 ~ 216	150	3
216 ~ 960	200	3
Above 960	500	3

Notes:

1. The lower limit shall apply at the transition frequencies.
2. Emission level (dBuV/m) = 20 log Emission level (uV/m).

## 5.9 Unwanted Emissions above 1 GHz

Radiated emissions which fall in the restricted bands must comply with the radiated emission limits specified as below table.

Frequencies (MHz)	Field Strength (microvolts/meter)	Measurement Distance (meters)
Above 960	500	3

Notes:

1. The lower limit shall apply at the transition frequencies.
2. Emission level (dBuV/m) = 20 log Emission level (uV/m).
3. For frequencies above 1000 MHz, the field strength limits are based on average detector, however, the peak field strength of any emission shall not exceed the maximum permitted average limits, specified above by more than 20 dB under any condition of modulation.

Limits of unwanted emission out of the restricted bands

Applicable To	Limit	
789033 D02 General UNII Test Procedure New Rules v02r01	Field Strength at 3 m	
	PK: 74 (dBµV/m)	AV: 54 (dBµV/m)

For transmitters operating in the 5.15-5.25 GHz band:

Applicable To	EIRP Limit	Equivalent Field Strength at 3 m
15.407(b)(1)	PK: -27 (dBm/MHz)	PK: 68.2 (dBµV/m)

For transmitters operating in the 5.25-5.35 GHz band:

Applicable To	EIRP Limit	Equivalent Field Strength at 3 m
15.407(b)(2)	PK: -27 (dBm/MHz)	PK: 68.2 (dBµV/m)

For transmitters operating in the 5.47-5.725 GHz band:

Applicable To	EIRP Limit	Equivalent Field Strength at 3 m
15.407(b)(3)	PK: -27 (dBm/MHz)	PK: 68.2 (dBµV/m)

For transmitters operating in the 5.725-5.850 GHz band:

Applicable To	EIRP Limit	Equivalent Field Strength at 3 m
15.407(b)(4)(i)	PK: -27 (dBm/MHz) <sup>*1</sup>	PK: 68.2 (dBµV/m) <sup>*1</sup>
	PK: 10 (dBm/MHz) <sup>*2</sup>	PK: 105.2 (dBµV/m) <sup>*2</sup>
	PK: 15.6 (dBm/MHz) <sup>*3</sup>	PK: 110.8 (dBµV/m) <sup>*3</sup>
	PK: 27 (dBm/MHz) <sup>*4</sup>	PK: 122.2 (dBµV/m) <sup>*4</sup>

<sup>\*1</sup> beyond 75 MHz or more above of the band edge.

<sup>\*2</sup> below the band edge increasing linearly to 10 dBm/MHz at 25 MHz above.

<sup>\*3</sup> below the band edge increasing linearly to a level of 15.6 dBm/MHz at 5 MHz above.

<sup>\*4</sup> from 5 MHz above or below the band edge increasing linearly to a level of 27 dBm/MHz at the band edge.

Note: The following formula is used to convert the equipment isotropic radiated power (eirp) to field strength:

$$E = \frac{1000000 \sqrt{30P}}{3} \mu\text{V/m, where P is the eirp (Watts).}$$



## 6 Test Arrangements

### 6.1 26 dB Bandwidth

#### 6.1.1 Test Setup

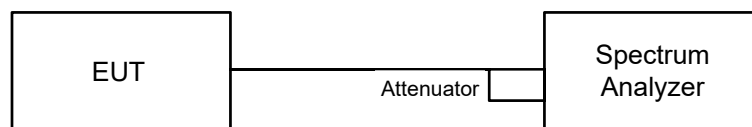

#### 6.1.2 Test Procedure

- Set RBW = approximately 1% of the emission bandwidth.
- Set the VBW > RBW.
- Detector = Peak.
- Trace mode = max hold.
- Measure the maximum width of the emission that is 26 dB down from the peak of the emission. Compare this with the RBW setting of the analyzer. Readjust RBW and repeat measurement as needed until the RBW/EBW ratio is approximately 1%.

### 6.2 RF Output Power

#### 6.2.1 Test Setup

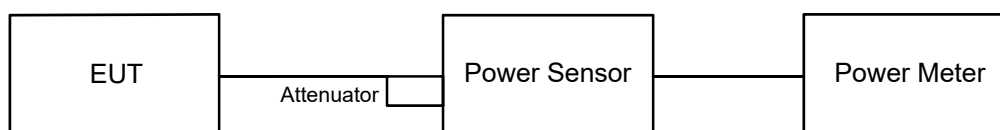

#### For channel straddling:

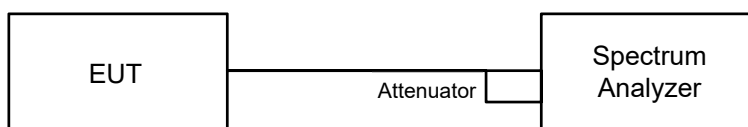

#### 6.2.2 Test Procedure

Method PM is used to perform output power measurement, trigger and gating function of wide band power meter is enabled to measure max output power of TX on burst and set the detector to average. Duty factor is not added to measured value.

#### For channel straddling:

##### Method SA-2

- Set span to encompass the entire emission bandwidth (EBW) of the signal.
- Set RBW = 1 MHz, Set VBW  $\geq$  3 MHz, Detector = RMS
- Sweep points  $\geq$   $[2 \times \text{span} / \text{RBW}]$ . (This gives bin-to-bin spacing  $\leq$  RBW / 2, so that narrowband signals are not lost between frequency bins.) Sweep time = auto, trigger set to "free run".
- Trace average at least 100 traces in power averaging mode.
- Use the peak search function on the instrument to find the peak of the spectrum and record its value.
- Record the max value and add  $10 \log (1/\text{duty cycle})$ .

Note: When measuring straddle channel power, use compute power by integrating the spectrum across the 26 dB EBW or 99% OBW of the signal using the instrument's band power measurement function, with band limits set equal to the EBW or OBW band edges. If the instrument does not have a band power function, then sum the spectrum levels (in power units) at 1 MHz intervals extending across the 26 dB EBW or 99% OBW of the spectrum.

## 6.3 Power Spectral Density

### 6.3.1 Test Setup

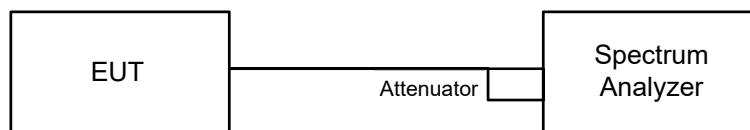

### 6.3.2 Test Procedure

#### For specified measurement bandwidth 1 MHz:

##### Method SA-2

- Set span to encompass the entire emission bandwidth (EBW) of the signal.
- Set RBW = 1 MHz, Set VBW  $\geq$  3 MHz, Detector = RMS
- Sweep points  $\geq$   $[2 \times \text{span} / \text{RBW}]$ . (This gives bin-to-bin spacing  $\leq$  RBW / 2, so that narrowband signals are not lost between frequency bins.)
- Sweep time = auto, trigger set to "free run".
- Trace average at least 100 traces in power averaging mode.
- Use the peak search function on the instrument to find the peak of the spectrum and record its value.
- Record the max value and add 10 log (1/duty cycle).

#### For specified measurement bandwidth 500 kHz:

##### Method SA-2

- Set span to encompass the entire emission bandwidth (EBW) of the signal.
- Set RBW = 300 kHz, Set VBW  $\geq$  1 MHz, Detector = RMS
- Scale the observed power level to an equivalent value in 500 kHz by adjusting (increasing) the measured power by a bandwidth correction factor (BWCF) where  $\text{BWCF} = 10\log(500 \text{ kHz}/300 \text{ kHz})$
- Sweep points  $\geq$   $[2 \times \text{span} / \text{RBW}]$ . (This gives bin-to-bin spacing  $\leq$  RBW / 2, so that narrowband signals are not lost between frequency bins.)
- Sweep time = auto, trigger set to "free run".
- Trace average at least 100 traces in power averaging mode.
- Use the peak search function on the instrument to find the peak of the spectrum and record its value.
- Record the max value and add 10 log (1/duty cycle).

## 6.4 6 dB Bandwidth

### 6.4.1 Test Setup

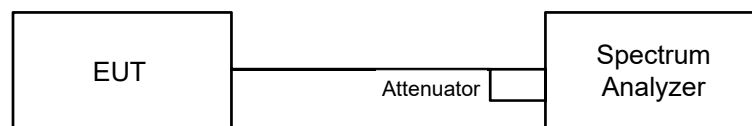

### 6.4.2 Test Procedure

- Set resolution bandwidth (RBW) = 100 kHz.
- Set the video bandwidth (VBW)  $\geq$  3 x RBW, Detector = Peak.
- Trace mode = max hold.
- Sweep = auto couple.
- Measure the maximum width of the emission that is constrained by the frequencies associated with the two amplitude points (upper and lower) that are attenuated by 6 dB relative to the maximum level measured in the fundamental emission.

## 6.5 Occupied Bandwidth

### 6.5.1 Test Setup

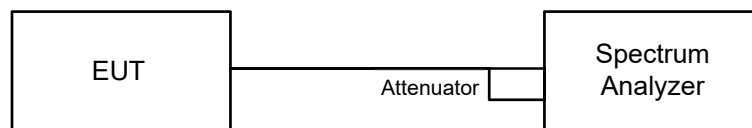

### 6.5.2 Test Procedure

The transmitter output was connected to the spectrum analyzer through an attenuator. The bandwidth of the fundamental frequency was measured by spectrum analyzer with resolution bandwidth in the range of 1% to 5% of the anticipated emission bandwidth, and a video bandwidth at least 3x the resolution bandwidth and set the detector to Sampling. The width of a frequency band such that, below the lower and above the upper frequency limits, the mean powers emitted are each equal to a specified percentage 0.5% of the total mean power of a given emission.

## 6.6 Frequency Stability

### 6.6.1 Test Setup

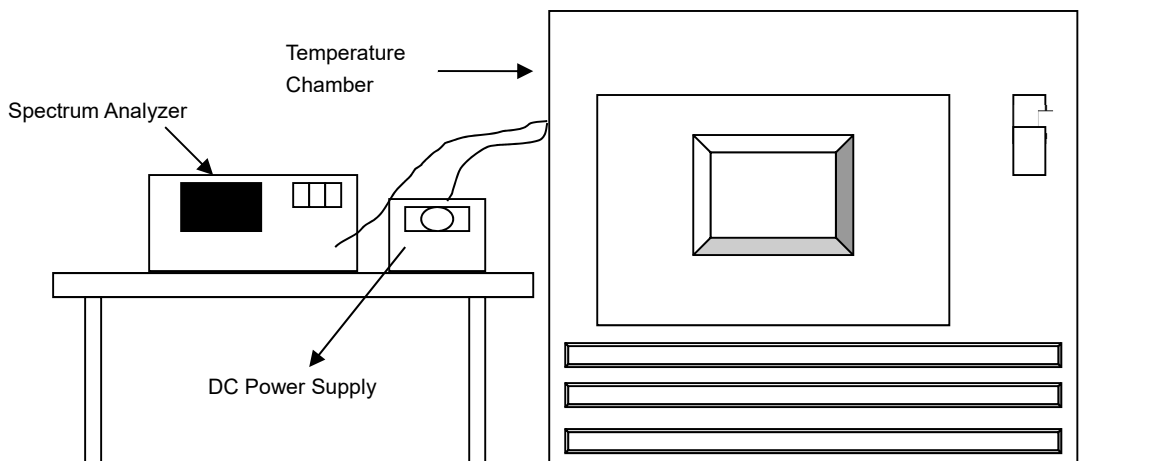

### 6.6.2 Test Procedure

- The EUT was placed inside the environmental test chamber and powered by nominal DC voltage.
- Turn the EUT on and couple its output to a spectrum analyzer.
- Turn the EUT off and set the chamber to the highest temperature specified.
- Allow sufficient time (approximately 30 min) for the temperature of the chamber to stabilize, turn the EUT on and measure the operating frequency after 2, 5, and 10 Minutes.
- Repeat step (d) with the temperature chamber set to the next desired temperature until measurements down to the lowest specified temperature have been completed.
- The test chamber was allowed to stabilize at +20 degree C for a minimum of 30 Minutes. The supply voltage was then adjusted on the EUT from 85% to 115% and the frequency record.

## 6.7 AC Power Conducted Emissions

### 6.7.1 Test Setup

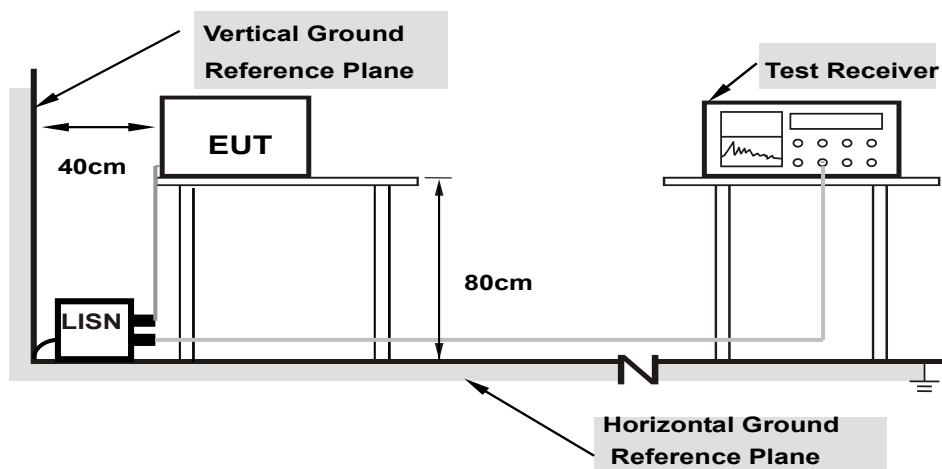

**Note: 1. Support units were connected to second LISN.**

For the actual test configuration, please refer to the attached file (Test Setup Photo).

### 6.7.2 Test Procedure

- The EUT was placed on a 0.8 meter to the top of table and placed 0.4 meters from the conducting wall of the shielded room with EUT being connected to the power mains through a line impedance stabilization network (LISN). Other support units were connected to the power mains through another LISN. The two LISNs provide 50 ohm/ 50 uH of coupling impedance for the measuring instrument.
- Both lines of the power mains connected to the EUT were checked for maximum conducted interference.
- The frequency range from 150 kHz to 30 MHz was searched. Emission levels under (Limit – 20 dB) was not recorded.

Note: The resolution bandwidth and video bandwidth of test receiver is 9 kHz for quasi-peak detection (QP) and average detection (AV) at frequency 0.15 MHz-30 MHz.

## 6.8 Unwanted Emissions below 1 GHz

### 6.8.1 Test Setup

For Radiated Configuration:

For Radiated emission below 30 MHz

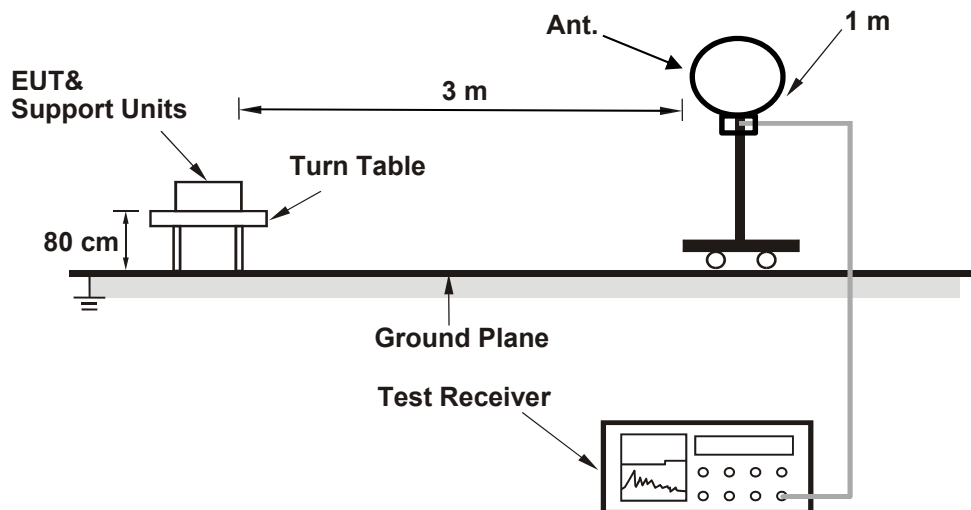

For Radiated emission above 30 MHz

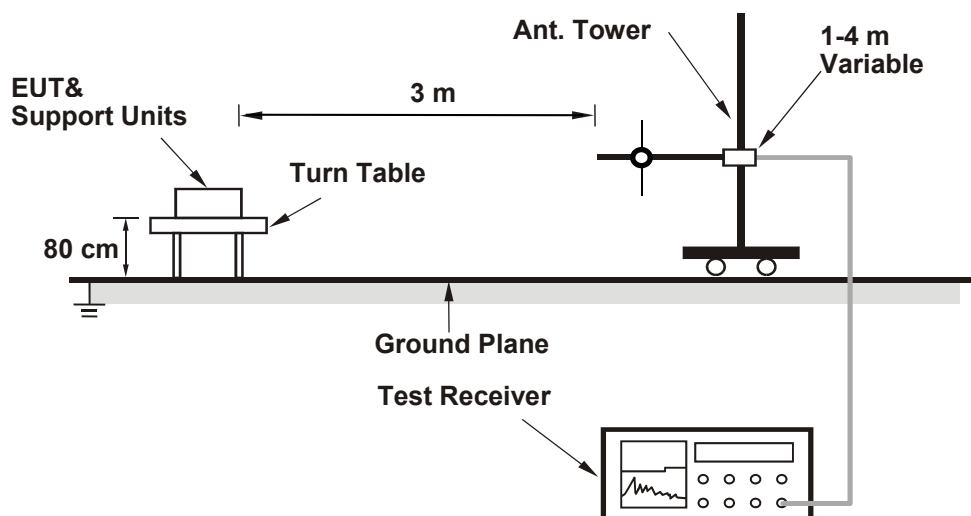

For Conducted Configuration:

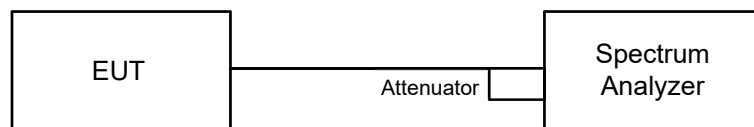

For the actual test configuration, please refer to the attached file (Test Setup Photo).

## 6.8.2 Test Procedure

### Radiated versus Conducted Measurement.

The unwanted emission limits in both the restricted and non-restricted bands are based on antenna-port conducted measurements in conjunction with cabinet emissions tests are permitted to demonstrate compliance.

The following steps was performed:

- a. Cabinet emissions measurements. Radiated measurement was performed to ensure that cabinet emissions are below the emission limits. For the cabinet-emission measurements the antenna was replaced by a termination matching the nominal impedance of the antenna.
- b. Conducted tests was performed using equipment that matches the nominal impedance of the antenna assembly used with the EUT.
- c. EIRP calculation. A value representative of an upper bound on out-of-band antenna gain (in dBi) shall be added to the measured antenna-port conducted emission power to compute EIRP within the specified measurement bandwidth. (For emissions in the restricted bands, additional calculations are required to convert EIRP to field strength at the specified distance.) The upper bound on antenna gain for a device with a single RF output shall be selected as the maximum in-band gain of the antenna across all operating bands or 2 dBi, whichever is greater.
- d. EIRP adjustments for multiple outputs. (Follow the procedures specified in FCC KDB Publication 662911)
- e. For all of Radiation emission test

#### **For Radiated emission below 30 MHz**

- e-1.1. The EUT was placed on the top of a rotating table 0.8 meters above the ground at 3 meter chamber room for test. The table was rotated 360 degrees to determine the position of the highest radiation.
- e-1.2. The EUT was set 3 meters away from the interference-receiving antenna, which was mounted on the top of a variable-height antenna tower.
- e-1.3. Parallel, perpendicular, and ground-parallel orientations of the antenna are set to make the measurement.
- e-1.4. For each suspected emission, the EUT was arranged to its worst case and the rotatable table was turned from 0 degrees to 360 degrees to find the maximum reading.
- e-1.5. The test-receiver system was set to Quasi-Peak Detect Function and Specified Bandwidth with Maximum Hold Mode, except for the frequency band (9 kHz to 90 kHz and 110 kHz to 490 kHz) set to average detect function and peak detect function.

#### Notes:

1. The resolution bandwidth and video bandwidth of test receiver/spectrum analyzer is 200 Hz at frequency below 150 kHz.
2. The resolution bandwidth and video bandwidth of test receiver/spectrum analyzer is 9 kHz or 10 kHz at frequency (150 kHz to 30 MHz).
3. All modes of operation were investigated and the worst-case emissions are reported.

#### **For Radiated emission above 30 MHz**

- e-2.1. The EUT was placed on the top of a rotating table 0.8 meters above the ground at 3 meter chamber room for test. The table was rotated 360 degrees to determine the position of the highest radiation.
- e-2.2. The EUT was set 3 meters away from the interference-receiving antenna, which was mounted on the top of a variable-height antenna tower.
- e-2.3. The height of antenna is varied from one meter to four meters above the ground to determine the maximum value of the field strength. Both horizontal and vertical polarizations of the antenna are set to make the measurement.
- e-2.4. For each suspected emission, the EUT was arranged to its worst case and then the antenna was tuned to heights from 1 meter to 4 meters and the rotatable table was turned from 0 degrees to 360 degrees to find the maximum reading.
- e-2.5. The test-receiver system was set to quasi-peak detect function and specified bandwidth with maximum hold mode when the test frequency is below 1 GHz.

#### Notes:

1. The resolution bandwidth and video bandwidth of test receiver/spectrum analyzer is 120 kHz for Quasi-peak detection (QP) at frequency below 1 GHz.
2. All modes of operation were investigated and the worst-case emissions are reported.



### Radiated versus Conducted Measurement

#### For Radiated measurement:

The level of unwanted emissions was measured when radiated by the cabinet or structure of the equipment with the antenna connector(s) terminated by a specified load (cabinet radiation).

#### For Conducted measurement:

The level of unwanted emissions was measured as their power in a specified load (conducted spurious emissions).

### Conducted Unwanted Emission Convert Formula

- a. Emission Level (dBuV/m) = EIRP Level (dBm) – 20log(d) + 104.8  
d = measurement distance in 3 meters.
- b. EIRP Level (dBm) = Raw Value(dBm) + Correction Factor(dB)
- c. Correction Factor is directional gain, and the composite gain will be used when signal support the correlated signal  
For the out of band spurious the gain for the specific band may have been used rather than the highest gain across all bands.  
For the band edge the gain for the specific band may have been used.

#### Notes:

1. In restricted bands below 1000 MHz, add upper bound on ground plane reflection:  
For frequencies between 30 MHz and 1000 MHz, add 4.7 dB.
2. The conducted emission test was considered some factor to compute test result.

## 6.9 Unwanted Emissions above 1 GHz

### 6.9.1 Test Setup

#### For Radiated Configuration:

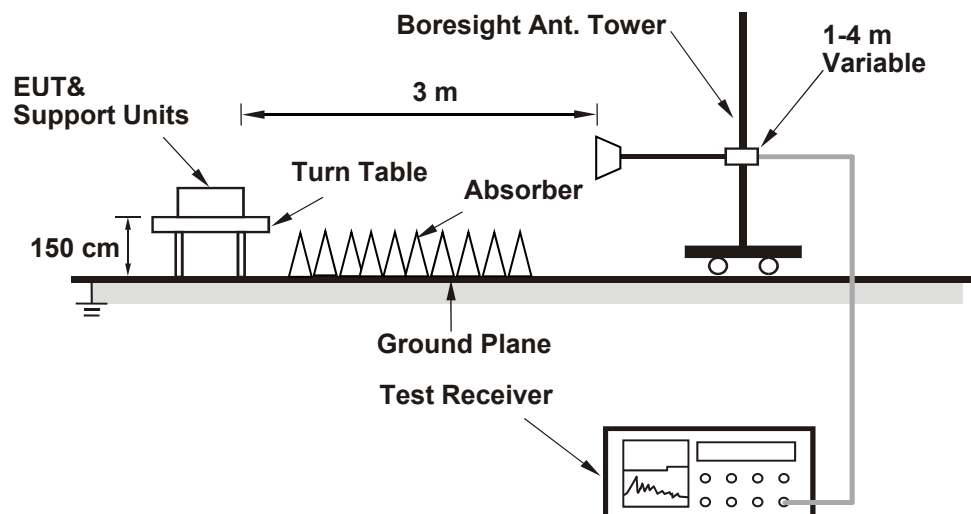

#### For Conducted Configuration:

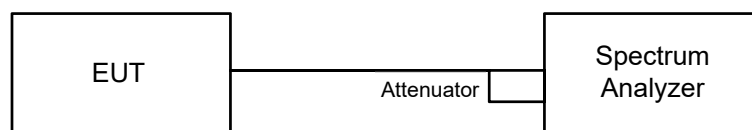

For the actual test configuration, please refer to the attached file (Test Setup Photo).

### 6.9.2 Test Procedure

#### Radiated versus Conducted Measurement.

The unwanted emission limits in both the restricted and non-restricted bands are based on antenna-port conducted measurements in conjunction with cabinet emissions tests are permitted to demonstrate compliance.

The following steps was performed:

- a. Cabinet emissions measurements. Radiated measurement was performed to ensure that cabinet emissions are below the emission limits. For the cabinet-emission measurements the antenna was replaced by a termination matching the nominal impedance of the antenna.
- b. Conducted tests was performed using equipment that matches the nominal impedance of the antenna assembly used with the EUT.
- c. EIRP calculation. A value representative of an upper bound on out-of-band antenna gain (in dBi) shall be added to the measured antenna-port conducted emission power to compute EIRP within the specified measurement bandwidth. (For emissions in the restricted bands, additional calculations are required to convert EIRP to field strength at the specified distance.) The upper bound on antenna gain for a device with a single RF output shall be selected as the maximum in-band gain of the antenna across all operating bands or 2 dBi, whichever is greater.
- d. EIRP adjustments for multiple outputs. (Follow the procedures specified in FCC KDB Publication 662911)
- e. For all of Radiation emission test
  - e-1. The EUT was placed on the top of a rotating table 1.5 meters above the ground at 3 meter chamber room for test. The table was rotated 360 degrees to determine the position of the highest radiation.
  - e-2. The EUT was set 3 meters away from the interference-receiving antenna, which was mounted on the top of a variable-height antenna tower.



- e-3. The height of antenna is varied from one meter to four meters above the ground to determine the maximum value of the field strength. Both horizontal and vertical polarizations of the antenna are set to make the measurement.
- e-4. For each suspected emission, the EUT was arranged to its worst case and then the antenna was tuned to heights from 1 meter to 4 meters and the rotatable table was turned from 0 degrees to 360 degrees to find the maximum reading.
- e-5. The test-receiver system was set to peak and average detects function and specified bandwidth with maximum hold mode when the test frequency is above 1 GHz. If the peak reading value also meets average limit, measurement with the average detector is unnecessary.

Notes:

1. The resolution bandwidth of test receiver/spectrum analyzer is 1 MHz and the video bandwidth is 3 MHz for Peak detection (PK) and Average detection (AV) at frequency above 1 GHz.
2. For fundamental and harmonic signal measurement, the resolution bandwidth of test receiver/spectrum analyzer is 1 MHz and the video bandwidth is  $\geq 1/T$  (Duty cycle < 98%) or 10 Hz (Duty cycle  $\geq 98\%$ ) for Average detection (AV) at frequency above 1 GHz.
3. All modes of operation were investigated and the worst-case emissions are reported.

<b>Radiated versus Conducted Measurement</b>
<p><u>For Radiated measurement:</u> The level of unwanted emissions was measured when radiated by the cabinet or structure of the equipment with the antenna connector(s) terminated by a specified load (cabinet radiation).</p> <p><u>For Conducted measurement:</u> The level of unwanted emissions was measured as their power in a specified load (conducted spurious emissions).</p> <p><u>For Verified radiated measurement:</u> The level of unwanted emissions was measured when radiated by the cabinet or structure of the equipment with the antenna connector(s) terminated by a specified load (cabinet radiation).</p>
<b>Conducted Unwanted Emission Convert Formula</b>
<p>a. Emission Level (dBuV/m) = EIRP Level (dBm) – 20log(d) + 104.8 d = measurement distance in 3 meters.</p> <p>b. EIRP Level (dBm) = Raw Value(dBm) + Correction Factor(dB).</p> <p>c. Correction Factor is directional gain, and the composite gain will be used when signal support the correlated signal For the out of band spurious the gain for the specific band may have been used rather than the highest gain across all bands. For the band edge the gain for the specific band may have been used.</p> <p>Note: The conducted emission test was considered some factor to compute test result.</p>

## 7 Test Results of Test Item

### 7.1 26 dB Bandwidth

Input Power:	3.3 Vdc	Environmental Conditions:	25°C, 60% RH	Tested By:	Willy Lin
--------------	---------	---------------------------	--------------	------------	-----------

For 1S1T

802.11be (EHT20)

Channel	Frequency (MHz)	26 dB Bandwidth (MHz)
52	5260	28.09
60	5300	28.55
64	5320	21.97
100	5500	19.97
116	5580	22.34
140	5700	21.66
144 (U-NII-2C)	5720	18.62
144 (U-NII-3)	5720	5.31

Determined Output Power Limit			
Channel Number	Freq.(MHz)	Min. B(MHz)	Determined Conducted Power Limit (dBm)
52	5260	28.09	25.48 > 24
60	5300	28.55	25.55 > 24
64	5320	21.97	24.41 > 24
100	5500	19.97	24 = 24
116	5580	22.34	24.49 > 24
140	5700	21.66	24.35 > 24
144 (U-NII-2C)	5720	18.62	23.69 < 24

Note: For U-NII-2A, U-NII-2C Band output power limitation is determined based on 26dBc bandwidth.

**802.11be (EHT40)**

Channel	Frequency (MHz)	26 dB Bandwidth (MHz)
54	5270	46.44
62	5310	40.18
102	5510	43.03
110	5550	57.22
134	5670	46.43
142 (U-NII-2C)	5710	38.93
142 (U-NII-3)	5710	12.61

Determined Output Power Limit			
Channel Number	Freq.(MHz)	Min. B(MHz)	Determined Conducted Power Limit (dBm)
54	5270	46.44	27.66 > 24
62	5310	40.18	27.04 > 24
102	5510	43.03	27.33 > 24
110	5550	57.22	28.57 > 24
134	5670	46.43	27.66 > 24
142 (U-NII-2C)	5710	38.93	26.9 > 24

Note: For U-NII-2A, U-NII-2C Band output power limitation is determined based on 26dBc bandwidth.

**802.11be (EHT80)**

Channel	Frequency (MHz)	26 dB Bandwidth (MHz)
58	5290	94.17
106	5530	93.2
122	5610	80.19
138 (U-NII-2C)	5690	85.85
138 (U-NII-3)	5690	10.33

Determined Output Power Limit			
Channel Number	Freq.(MHz)	Min. B(MHz)	Determined Conducted Power Limit (dBm)
58	5290	94.17	30.73 > 24
106	5530	93.20	30.69 > 24
122	5610	80.19	30.04 > 24
138 (U-NII-2C)	5690	85.85	30.33 > 24

Note: For U-NII-2A, U-NII-2C Band output power limitation is determined based on 26dBc bandwidth.

### 802.11be (EHT160)

Channel	Frequency (MHz)	26 dB Bandwidth (MHz)
50 (U-NII-1)	5250	83.16
50 (U-NII-2A)	5250	82.8
114	5570	167.41

#### Determined Output Power Limit

Channel Number	Freq.(MHz)	Min. B(MHz)	Determined Conducted Power Limit (dBm)	
50 (U-NII-2A)	5250	82.80	30.18	> 24
114	5570	167.41	33.23	> 24

Note: For U-NII-2A, U-NII-2C Band output power limitation is determined based on 26dBc bandwidth.

### 802.11be (EHT20) 26-tone RU

Channel	Frequency (MHz)	26 dB Bandwidth (MHz)
64	5320	19.6
100	5500	19.57
140	5700	19.61

#### Determined Output Power Limit

Channel Number	Freq.(MHz)	Min. B(MHz)	Determined Conducted Power Limit (dBm)	
64	5320	19.60	23.92	< 24
100	5500	19.57	23.91	< 24
140	5700	19.61	23.92	< 24

Note: For U-NII-2A, U-NII-2C Band output power limitation is determined based on 26dBc bandwidth.

### 802.11be (EHT20) 52-tone RU

Channel	Frequency (MHz)	26 dB Bandwidth (MHz)
64	5320	19.71
100	5500	19.71
140	5700	19.64

#### Determined Output Power Limit

Channel Number	Freq.(MHz)	Min. B(MHz)	Determined Conducted Power Limit (dBm)	
64	5320	19.71	23.94	< 24
100	5500	19.71	23.94	< 24
140	5700	19.64	23.93	< 24

Note: For U-NII-2A, U-NII-2C Band output power limitation is determined based on 26dBc bandwidth.

### 802.11be (EHT20) 106-tone RU

Channel	Frequency (MHz)	26 dB Bandwidth (MHz)
64	5320	22.03
100	5500	24.4
140	5700	20.19

#### Determined Output Power Limit

Channel Number	Freq.(MHz)	Min. B(MHz)	Determined Conducted Power Limit (dBm)		
64	5320	22.03	24.43	>	24
100	5500	24.40	24.87	>	24
140	5700	20.19	24.05	>	24

Note: For U-NII-2A, U-NII-2C Band output power limitation is determined based on 26dBc bandwidth.

### 802.11be (EHT20) 52+26-tone MRU

Channel	Frequency (MHz)	26 dB Bandwidth (MHz)
64	5320	18.89
100	5500	19.15
140	5700	19.06

#### Determined Output Power Limit

Channel Number	Freq.(MHz)	Min. B(MHz)	Determined Conducted Power Limit (dBm)		
64	5320	18.89	23.76	<	24
100	5500	19.15	23.82	<	24
140	5700	19.06	23.8	<	24

Note: For U-NII-2A, U-NII-2C Band output power limitation is determined based on 26dBc bandwidth.

**802.11be (EHT20) 106+26-tone MRU**

Channel	Frequency (MHz)	26 dB Bandwidth (MHz)
64	5320	20.6
100	5500	19.62
140	5700	19.72

**Determined Output Power Limit**

Channel Number	Freq.(MHz)	Min. B(MHz)	Determined Conducted Power Limit (dBm)		
64	5320	20.60	24.13	>	24
100	5500	19.62	23.92	<	24
140	5700	19.72	23.94	<	24

Note: For U-NII-2A, U-NII-2C Band output power limitation is determined based on 26dBc bandwidth.

**802.11be (EHT80) 484+242-tone MRU**

Channel	Frequency (MHz)	26 dB Bandwidth (MHz)
58	5290	80.83
106	5530	80.55
138 (U-NII-2C)	5690	83.45
138 (U-NII-3)	5690	5.23

**Determined Output Power Limit**

Channel Number	Freq.(MHz)	Min. B(MHz)	Determined Conducted Power Limit (dBm)		
58	5290	80.83	30.07	>	24
106	5530	80.55	30.06	>	24
138 (U-NII-2C)	5690	83.45	30.21	>	24

Note: For U-NII-2A, U-NII-2C Band output power limitation is determined based on 26dBc bandwidth.

**802.11be (EHT160) 996+484-tone MRU**

Channel	Frequency (MHz)	26 dB Bandwidth (MHz)
50 (U-NII-1)	5250	82.36
50 (U-NII-2A)	5250	43.38
114	5570	164.17

**Determined Output Power Limit**

Channel Number	Freq.(MHz)	Min. B(MHz)	Determined Conducted Power Limit (dBm)	
50 (U-NII-2A)	5250	43.38	27.37	> 24
114	5570	164.17	33.15	> 24

Note: For U-NII-2A, U-NII-2C Band output power limitation is determined based on 26dBc bandwidth.

**802.11be (EHT160) 996+484+242-tone MRU**

Channel	Frequency (MHz)	26 dB Bandwidth (MHz)
50 (U-NII-1)	5250	82.18
50 (U-NII-2A)	5250	79.84
114	5570	164.21

**Determined Output Power Limit**

Channel Number	Freq.(MHz)	Min. B(MHz)	Determined Conducted Power Limit (dBm)	
50 (U-NII-2A)	5250	79.84	30.02	> 24
114	5570	164.21	33.15	> 24

Note: For U-NII-2A, U-NII-2C Band output power limitation is determined based on 26dBc bandwidth.

### Spectrum Plot of Minimum Value

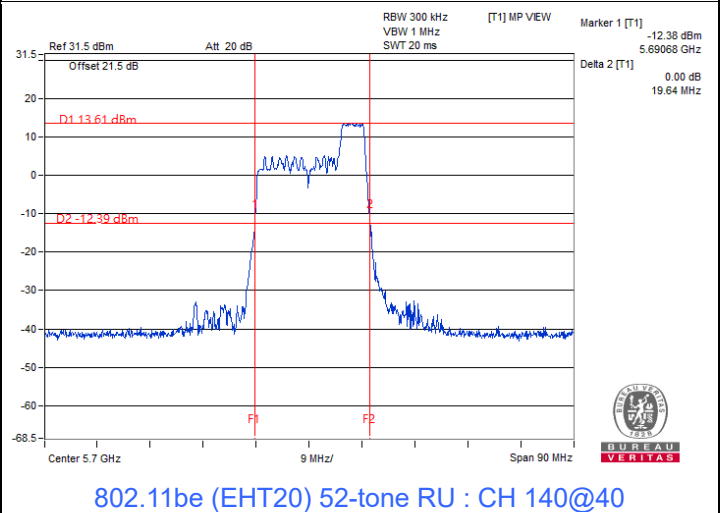
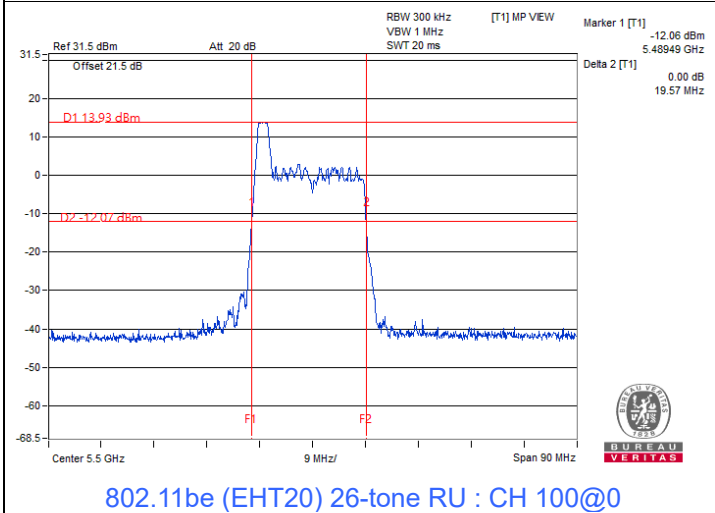
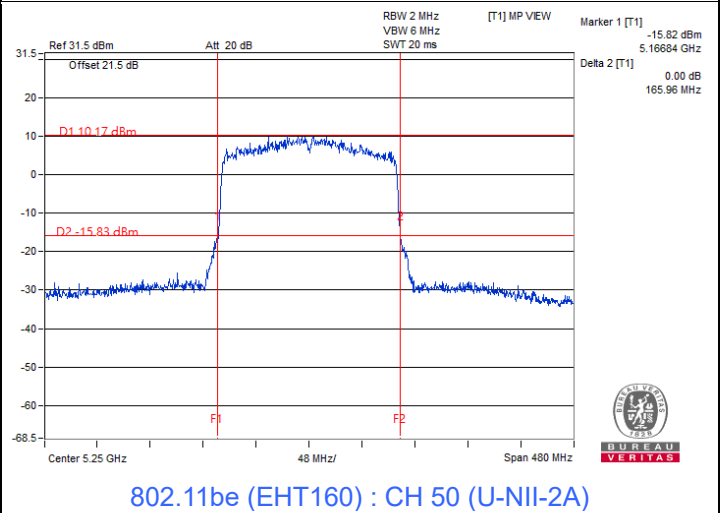
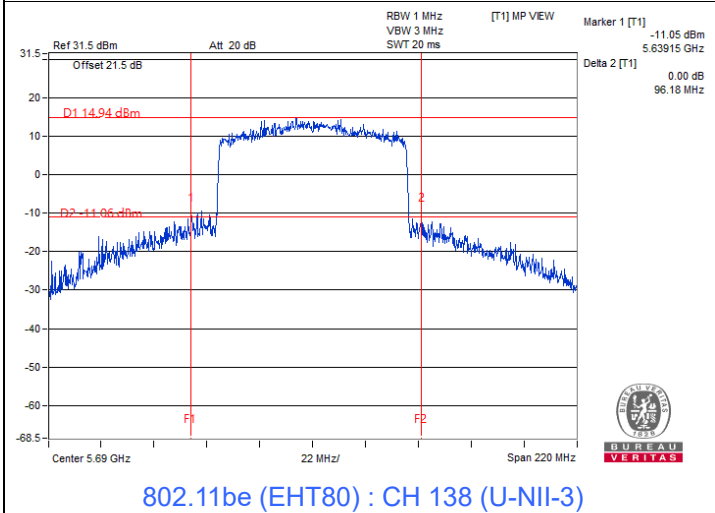
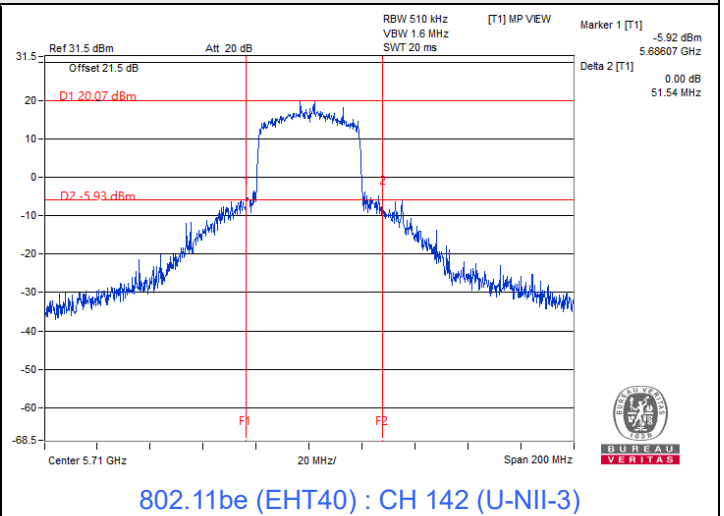
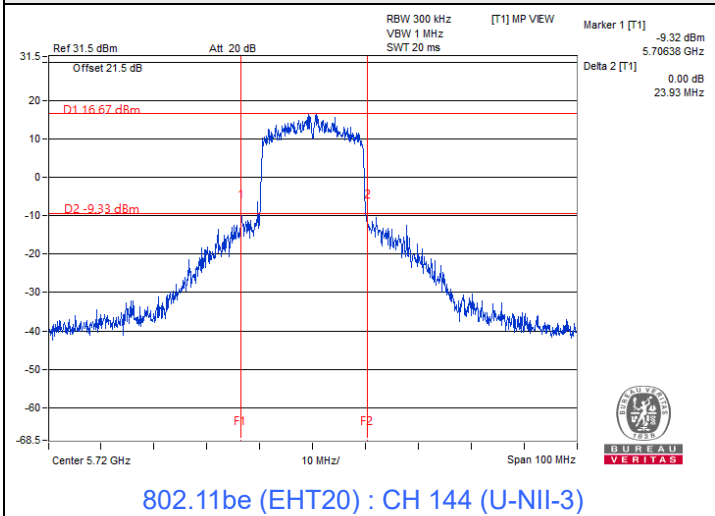



### Spectrum Plot of Minimum Value

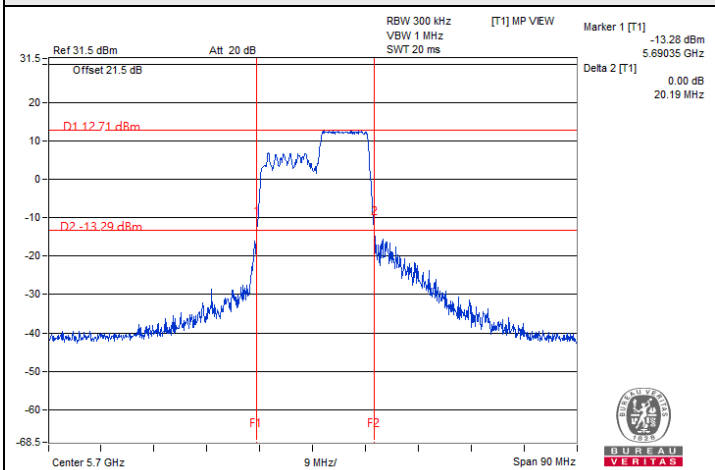

802.11be (EHT20) 106-tone RU : CH 140@54

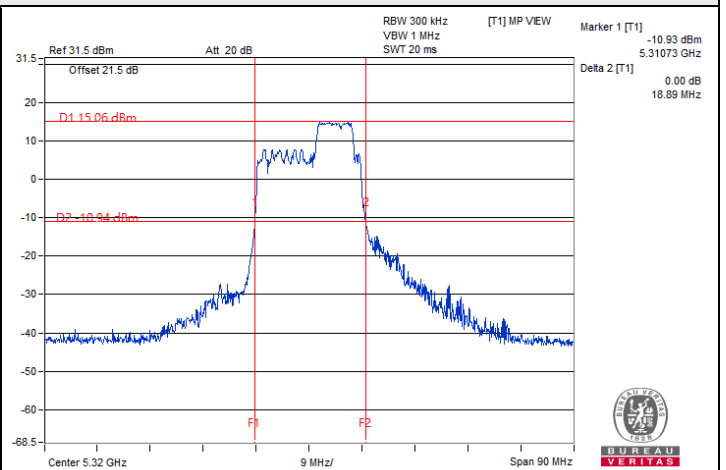

802.11be (EHT20) 52+26-tone MRU : CH 64@72

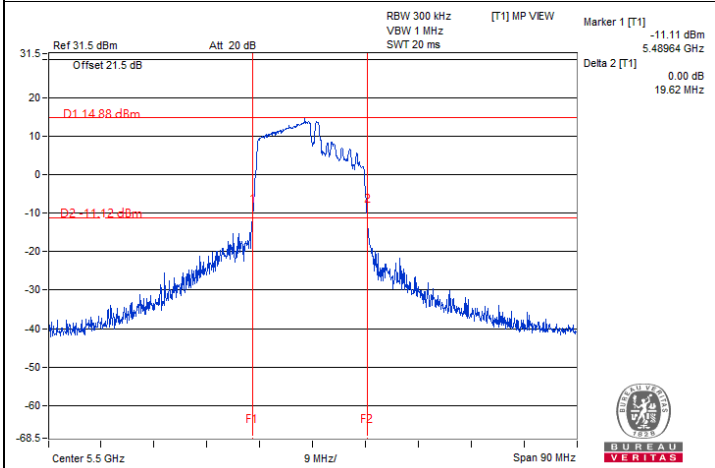

802.11be (EHT20) 106+26-tone MRU : CH 100@82

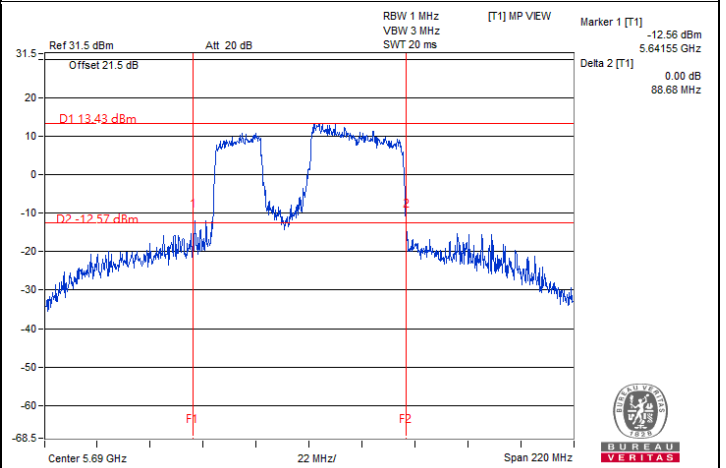

802.11be (EHT80) 484+242-tone MRU : CH 138@91 (U-NII-3)

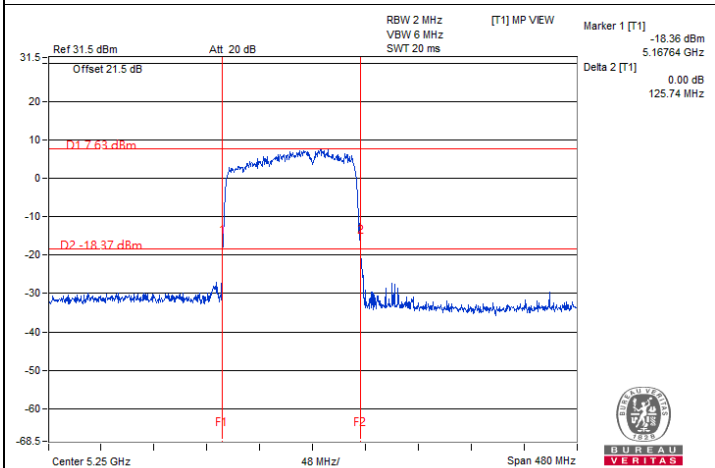

802.11be (EHT160) 996+484-tone MRU : CH 50@95-1 (U-NII-2A)

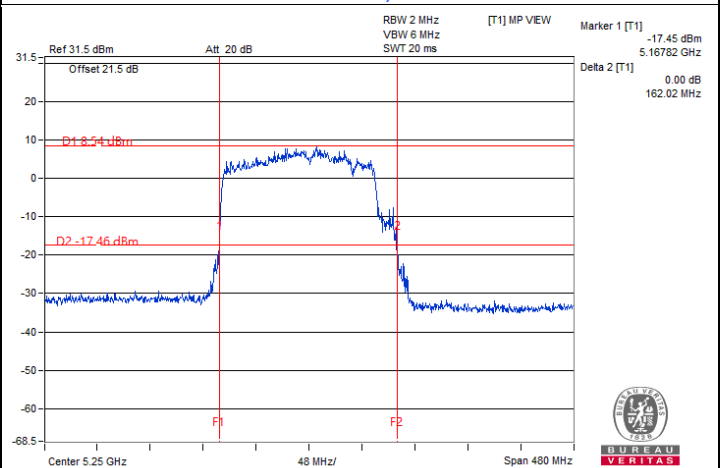

802.11be (EHT160) 996+484+242-tone MRU : CH 50@99-1 (U-NII-2A)

Notes:

1. For U-NII-2C straddle channel = 5725 MHz - Marker 1
2. For U-NII-3 straddle channel = Marker 1 + Delta 2 - 5725 MHz
3. For U-NII-1 straddle channel = 5250 MHz - Marker 1
4. For U-NII-2A straddle channel = Marker 1 + Delta 2 - 5250 MHz

**For 2S2T**

**802.11be (EHT20)**

Channel	Frequency (MHz)	26 dB Bandwidth (MHz)	
		Chain 0	Chain 1
52	5260	19.80	19.93
60	5300	23.44	19.98
64	5320	19.91	20.08
100	5500	20.21	20.50
116	5580	19.94	19.90
140	5700	20.00	21.61
144 (U-NII-2C)	5720	14.95	14.99
144 (U-NII-3)	5720	4.88	4.86

Determined Output Power Limit			
Channel Number	Freq.(MHz)	Min. B(MHz)	Determined Conducted Power Limit (dBm)
52	5260	19.80	23.96 < 24
60	5300	19.98	24 = 24
64	5320	19.91	23.99 < 24
100	5500	20.21	24.05 > 24
116	5580	19.90	23.98 < 24
140	5700	20.00	24.01 > 24
144 (U-NII-2C)	5720	14.95	22.74 < 24

Note: For U-NII-2A, U-NII-2C Band output power limitation is determined based on 26dBc bandwidth.

**802.11be (EHT40)**

Channel	Frequency (MHz)	26 dB Bandwidth (MHz)	
		Chain 0	Chain 1
54	5270	40.25	46.69
62	5310	42.79	48.48
102	5510	44.06	50.84
110	5550	43.52	51.27
134	5670	41.95	46.89
142 (U-NII-2C)	5710	35.43	35.13
142 (U-NII-3)	5710	5.12	5.27

Determined Output Power Limit			
Channel Number	Freq.(MHz)	Min. B(MHz)	Determined Conducted Power Limit (dBm)
54	5270	40.25	27.04 > 24
62	5310	42.79	27.31 > 24
102	5510	44.06	27.44 > 24
110	5550	43.52	27.38 > 24
134	5670	41.95	27.22 > 24
142 (U-NII-2C)	5710	35.13	26.45 > 24

Note: For U-NII-2A, U-NII-2C Band output power limitation is determined based on 26dBc bandwidth.

**802.11be (EHT80)**

Channel	Frequency (MHz)	26 dB Bandwidth (MHz)	
		Chain 0	Chain 1
58	5290	99.57	102.36
106	5530	103.05	95.20
122	5610	80.15	80.22
138 (U-NII-2C)	5690	90.22	88.28
138 (U-NII-3)	5690	5.19	5.17

Determined Output Power Limit			
Channel Number	Freq.(MHz)	Min. B(MHz)	Determined Conducted Power Limit (dBm)
58	5290	99.57	30.98 > 24
106	5530	95.20	30.78 > 24
122	5610	80.15	30.03 > 24
138 (U-NII-2C)	5690	88.28	30.45 > 24

Note: For U-NII-2A, U-NII-2C Band output power limitation is determined based on 26dBc bandwidth.

**802.11be (EHT160)**

Channel	Frequency (MHz)	26 dB Bandwidth (MHz)	
		Chain 0	Chain 1
50 (U-NII-1)	5250	83.17	83.04
50 (U-NII-2A)	5250	87.36	82.77
114	5570	167.84	168.05

Determined Output Power Limit			
Channel Number	Freq.(MHz)	Min. B(MHz)	Determined Conducted Power Limit (dBm)
50 (U-NII-2A)	5250	82.77	30.17 > 24
114	5570	167.84	33.24 > 24

Note: For U-NII-2A, U-NII-2C Band output power limitation is determined based on 26dBc bandwidth.

**802.11be (EHT20) 26-tone RU**

Channel	Frequency (MHz)	26 dB Bandwidth (MHz)	
		Chain 0	Chain 1
64	5320	19.56	19.52
100	5500	19.57	19.49
140	5700	19.63	19.57

Determined Output Power Limit			
Channel Number	Freq.(MHz)	Min. B(MHz)	Determined Conducted Power Limit (dBm)
64	5320	19.52	23.9 < 24
100	5500	19.49	23.89 < 24
140	5700	19.57	23.91 < 24

Note: For U-NII-2A, U-NII-2C Band output power limitation is determined based on 26dBc bandwidth.

**802.11be (EHT20) 52-tone RU**

Channel	Frequency (MHz)	26 dB Bandwidth (MHz)	
		Chain 0	Chain 1
64	5320	19.89	19.54
100	5500	19.81	19.64
140	5700	19.85	19.55

Determined Output Power Limit			
Channel Number	Freq.(MHz)	Min. B(MHz)	Determined Conducted Power Limit (dBm)
64	5320	19.54	23.9 < 24
100	5500	19.64	23.93 < 24
140	5700	19.55	23.91 < 24

Note: For U-NII-2A, U-NII-2C Band output power limitation is determined based on 26dBc bandwidth.

### 802.11be (EHT20) 106-tone RU

Channel	Frequency (MHz)	26 dB Bandwidth (MHz)	
		Chain 0	Chain 1
64	5320	20.27	21.01
100	5500	19.77	19.89
140	5700	20.28	19.58

Determined Output Power Limit			
Channel Number	Freq.(MHz)	Min. B(MHz)	Determined Conducted Power Limit (dBm)
64	5320	20.27	24.06 > 24
100	5500	19.77	23.96 < 24
140	5700	19.58	23.91 < 24

Note: For U-NII-2A, U-NII-2C Band output power limitation is determined based on 26dBc bandwidth.

### 802.11be (EHT20) 52+26-tone MRU

Channel	Frequency (MHz)	26 dB Bandwidth (MHz)	
		Chain 0	Chain 1
64	5320	19.15	19.08
100	5500	19.14	18.71
140	5700	19.48	19.05

Determined Output Power Limit			
Channel Number	Freq.(MHz)	Min. B(MHz)	Determined Conducted Power Limit (dBm)
64	5320	19.08	23.8 < 24
100	5500	18.71	23.72 < 24
140	5700	19.05	23.79 < 24

Note: For U-NII-2A, U-NII-2C Band output power limitation is determined based on 26dBc bandwidth.

**802.11be (EHT20) 106+26-tone MRU**

Channel	Frequency (MHz)	26 dB Bandwidth (MHz)	
		Chain 0	Chain 1
64	5320	19.51	19.52
100	5500	19.70	19.43
140	5700	19.52	19.50

Determined Output Power Limit			
Channel Number	Freq.(MHz)	Min. B(MHz)	Determined Conducted Power Limit (dBm)
64	5320	19.51	23.9 < 24
100	5500	19.43	23.88 < 24
140	5700	19.50	23.9 < 24

Note: For U-NII-2A, U-NII-2C Band output power limitation is determined based on 26dBc bandwidth.

**802.11be (EHT80) 484+242-tone MRU**

Channel	Frequency (MHz)	26 dB Bandwidth (MHz)	
		Chain 0	Chain 1
58	5290	80.84	80.66
106	5530	80.80	80.34
138 (U-NII-2C)	5690	75.27	78.23
138 (U-NII-3)	5690	5.15	5.28

Determined Output Power Limit			
Channel Number	Freq.(MHz)	Min. B(MHz)	Determined Conducted Power Limit (dBm)
58	5290	80.66	30.06 > 24
106	5530	80.34	30.04 > 24
138 (U-NII-2C)	5690	75.27	29.76 > 24

Note: For U-NII-2A, U-NII-2C Band output power limitation is determined based on 26dBc bandwidth.

**802.11be (EHT160) 996+484-tone MRU**

Channel	Frequency (MHz)	26 dB Bandwidth (MHz)	
		Chain 0	Chain 1
50 (U-NII-1)	5250	82.43	82.16
50 (U-NII-2A)	5250	43.32	43.02
114	5570	164.44	163.99

Determined Output Power Limit			
Channel Number	Freq.(MHz)	Min. B(MHz)	Determined Conducted Power Limit (dBm)
50 (U-NII-2A)	5250	43.02	27.33 > 24
114	5570	163.99	33.14 > 24

Note: For U-NII-2A, U-NII-2C Band output power limitation is determined based on 26dBc bandwidth.

**802.11be (EHT160) 996+484+242-tone MRU**

Channel	Frequency (MHz)	26 dB Bandwidth (MHz)	
		Chain 0	Chain 1
50 (U-NII-1)	5250	82.26	82.21
50 (U-NII-2A)	5250	80.32	77.99
114	5570	164.11	164.08

Determined Output Power Limit			
Channel Number	Freq.(MHz)	Min. B(MHz)	Determined Conducted Power Limit (dBm)
50 (U-NII-2A)	5250	77.99	29.92 > 24
114	5570	164.08	33.15 > 24

Note: For U-NII-2A, U-NII-2C Band output power limitation is determined based on 26dBc bandwidth.

### Spectrum Plot of Minimum Value

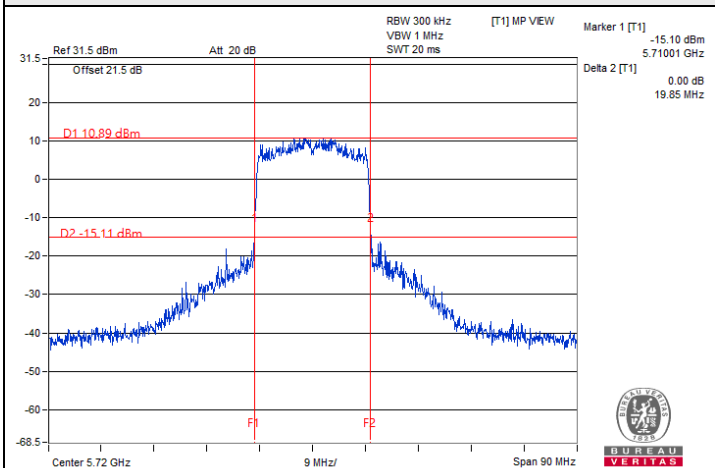

802.11be (EHT20) / Chain 1 : CH 144 (U-NII-3)

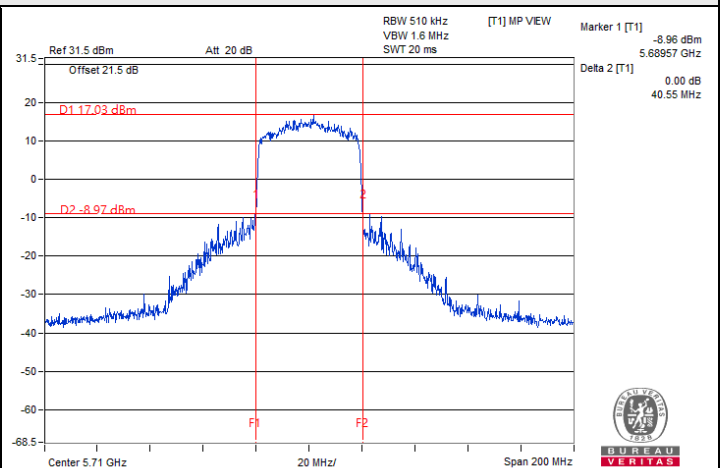

802.11be (EHT40) / Chain 0 : CH 142 (U-NII-3)

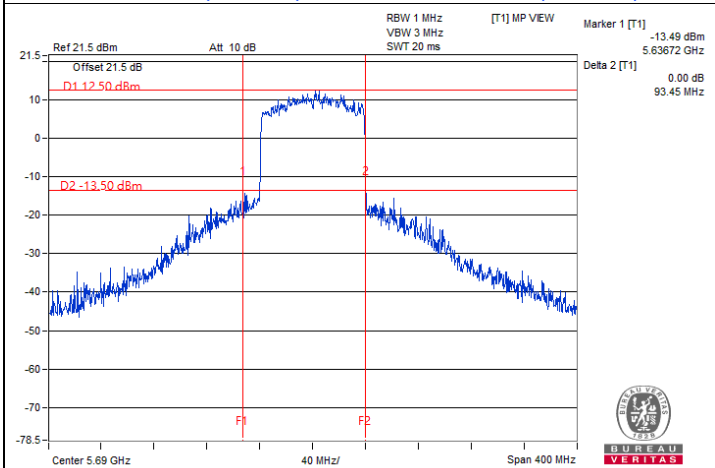

802.11be (EHT80) / Chain 1 : CH 138 (U-NII-3)

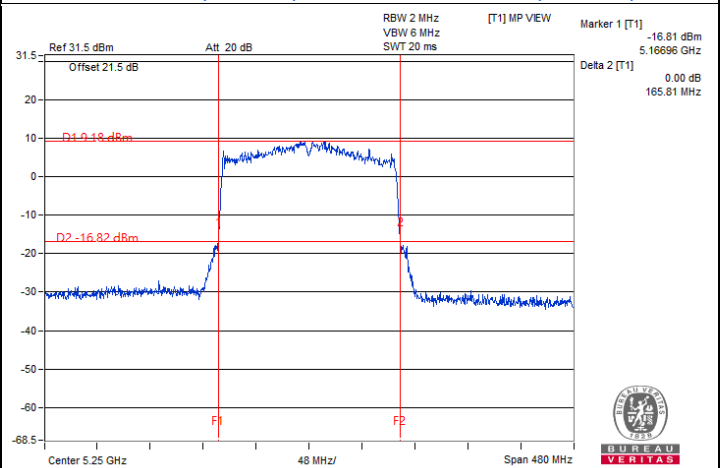

802.11be (EHT160) / Chain 1 : CH 50 (U-NII-2A)

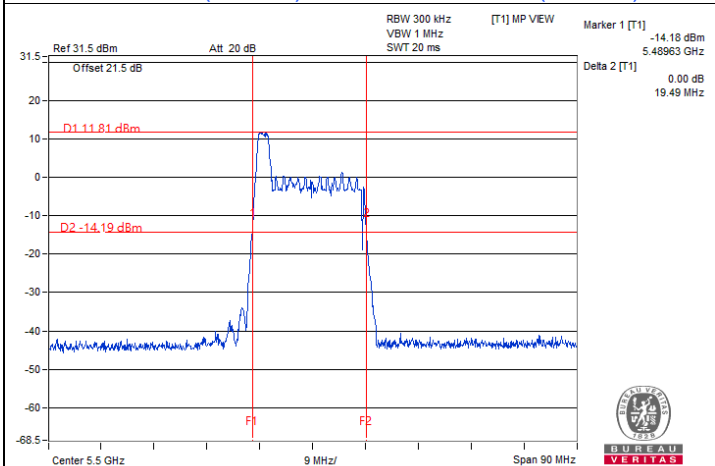

802.11be (EHT20) 26-tone RU / Chain 1 : CH 100@0

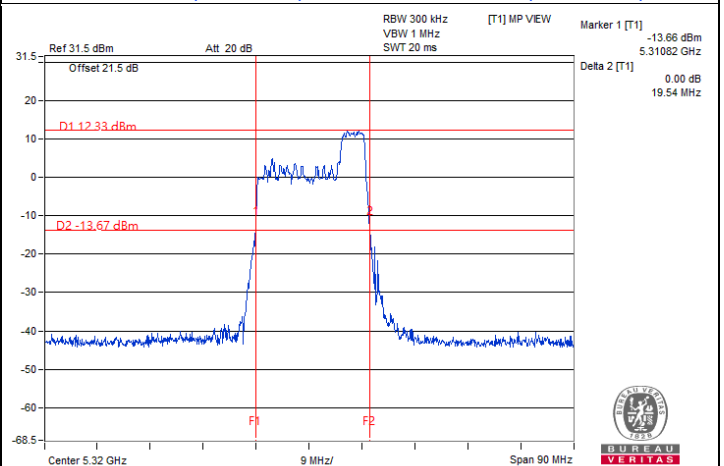

802.11be (EHT20) 52-tone RU / Chain 1 : CH 64@40



### Spectrum Plot of Minimum Value

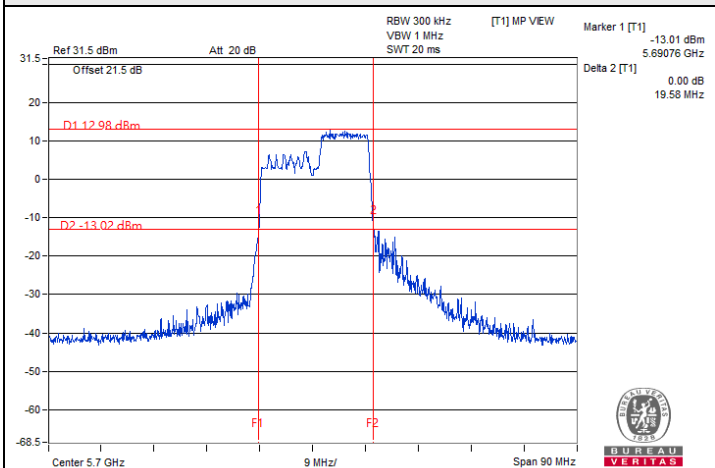

802.11be (EHT20) 106-tone RU / Chain 1 : CH 140@54

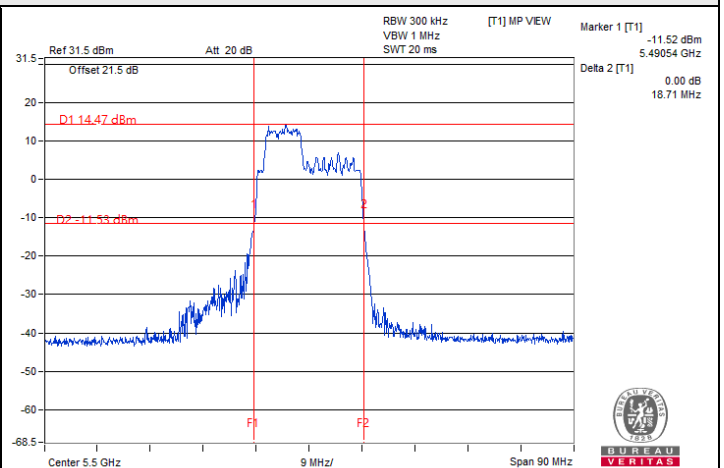

802.11be (EHT20) 52+26-tone MRU / Chain 1 : CH 100@70

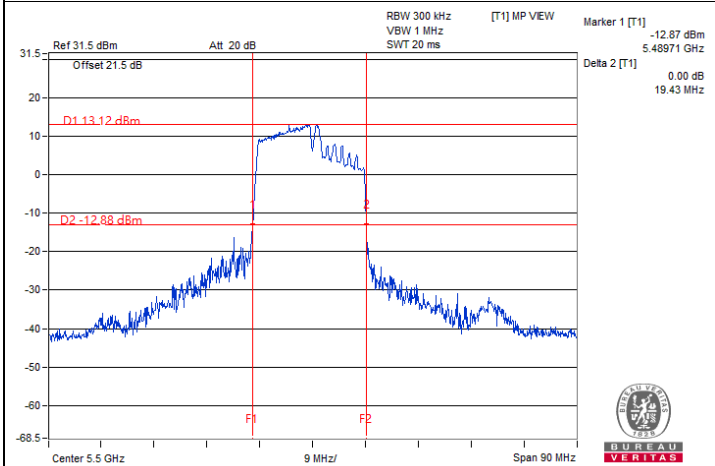

802.11be (EHT20) 106+26-tone MRU / Chain 1 : CH 100@82

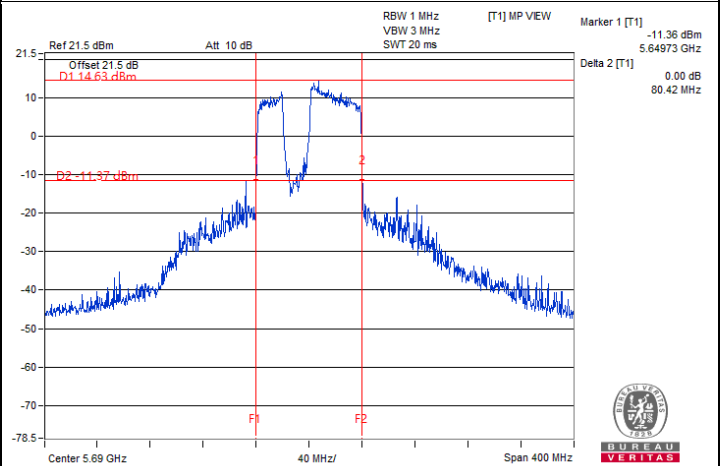

802.11be (EHT80) 484+242-tone MRU / Chain 0 : CH 138@91 (U-NII-3)

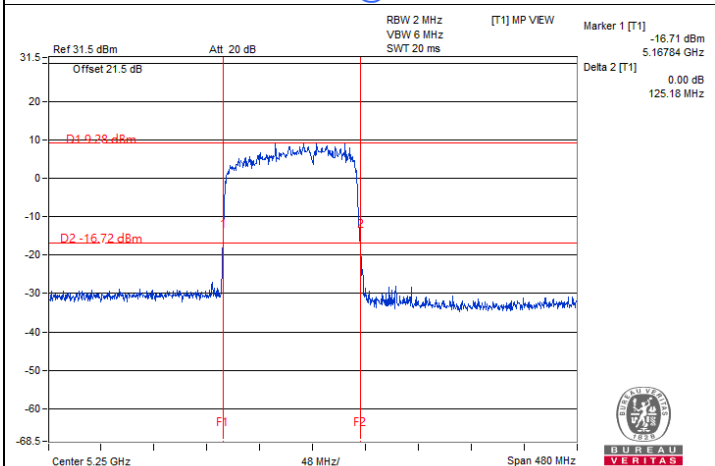

802.11be (EHT160) 996+484-tone MRU / Chain 1 : CH 50@95-1 (U-NII-2A)

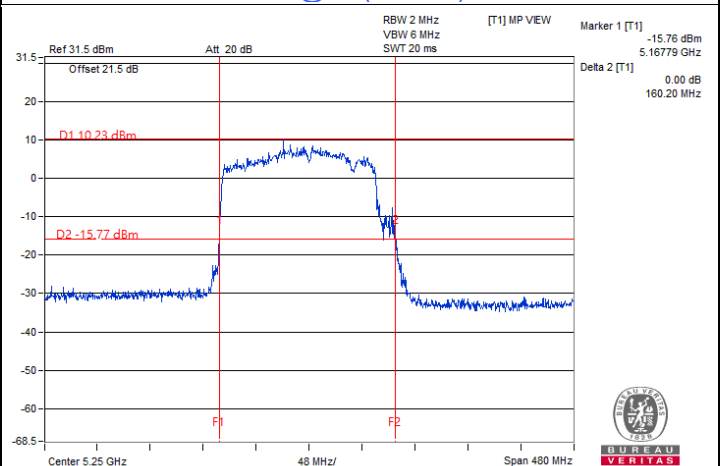

802.11be (EHT160) 996+484+242-tone MRU / Chain 1 : CH 50@99-1 (U-NII-2A)

**Notes:**

1. For U-NII-2C straddle channel = 5725 MHz - Marker 1
2. For U-NII-3 straddle channel = Marker 1 + Delta 2 - 5725 MHz
3. For U-NII-1 straddle channel = 5250 MHz - Marker 1
4. For U-NII-2A straddle channel = Marker 1 + Delta 2 - 5250 MHz

## 7.2 RF Output Power

Input Power:	3.3 Vdc	Environmental Conditions:	25°C, 60% RH	Tested By:	Willy Lin
--------------	---------	---------------------------	--------------	------------	-----------

### For 1S1T

#### 802.11be (EHT20)

Chan.	Chan. Freq. (MHz)	Average Power (mW)	Average Power (dBm)	Power Limit (dBm)	Test Result
52	5260	149.968	21.76	24	Pass
60	5300	149.624	21.75	24	Pass
64	5320	105.439	20.23	24	Pass
100	5500	94.189	19.74	24	Pass
116	5580	140.929	21.49	24	Pass
140	5700	79.25	18.99	24	Pass
*144 (U-NII-2C)	5720	144.919	21.61	23.69	Pass
*144 (U-NII-3)	5720	23.995	13.80	30	Pass

#### Notes:

- \* : Test was performed in accordance with measurement follow FCC KDB 789033 UNII test procedure Method SA-2 and use spectrum analyzer test , the duty factor was included in the total power.
- For U-NII-2A, the antenna gain is 4.92 dBi < 6 dBi, so the output power limit shall not be reduced.
- For U-NII-2C, the antenna gain is 4.92 dBi < 6 dBi, so the output power limit shall not be reduced.
- For U-NII-3, the antenna gain is 4.92 dBi < 6 dBi, so the output power limit shall not be reduced.

#### 802.11be (EHT40)

Chan.	Chan. Freq. (MHz)	Average Power (mW)	Average Power (dBm)	Power Limit (dBm)	Test Result
54	5270	160.694	22.06	24	Pass
62	5310	81.846	19.13	24	Pass
102	5510	79.983	19.03	24	Pass
110	5550	169.044	22.28	24	Pass
134	5670	115.08	20.61	24	Pass
*142 (U-NII-2C)	5710	141.448	21.51	24	Pass
*142 (U-NII-3)	5710	12.123	10.84	30	Pass

#### Notes:

- \* : Test was performed in accordance with measurement follow FCC KDB 789033 UNII test procedure Method SA-2 and use spectrum analyzer test , the duty factor was included in the total power.
- For U-NII-2A, the antenna gain is 4.92 dBi < 6 dBi, so the output power limit shall not be reduced.
- For U-NII-2C, the antenna gain is 4.92 dBi < 6 dBi, so the output power limit shall not be reduced.
- For U-NII-3, the antenna gain is 4.92 dBi < 6 dBi, so the output power limit shall not be reduced.

### 802.11be (EHT80)

Chan.	Chan. Freq. (MHz)	Average Power (mW)	Average Power (dBm)	Power Limit (dBm)	Test Result
58	5290	72.778	18.62	24	Pass
106	5530	73.114	18.64	24	Pass
122	5610	128.233	21.08	24	Pass
*138 (U-NII-2C)	5690	135.962	21.33	24	Pass
*138 (U-NII-3)	5690	6.345	8.02	30	Pass

Notes:

- \* : Test was performed in accordance with measurement follow FCC KDB 789033 UNII test procedure Method SA-2 and use spectrum analyzer test , the duty factor was included in the total power.
- For U-NII-2A, the antenna gain is 4.92 dBi < 6 dBi, so the output power limit shall not be reduced.
- For U-NII-2C, the antenna gain is 4.92 dBi < 6 dBi, so the output power limit shall not be reduced.
- For U-NII-3, the antenna gain is 4.92 dBi < 6 dBi, so the output power limit shall not be reduced.

### 802.11be (EHT160)

Chan.	Chan. Freq. (MHz)	Average Power (mW)	Average Power (dBm)	Power Limit (dBm)	Test Result
*50 (U-NII-1)	5250	27.536	14.40	24	Pass
*50 (U-NII-2A)	5250	26.297	14.20	24	Pass
114	5570	52.119	17.17	24	Pass

Notes:

- \* : Test was performed in accordance with measurement follow FCC KDB 789033 UNII test procedure Method SA-2 and use spectrum analyzer test , the duty factor was included in the total power.
- For U-NII-1, the antenna gain is 4.92 dBi < 6 dBi, so the output power limit shall not be reduced.
- For U-NII-2A, the antenna gain is 4.92 dBi < 6 dBi, so the output power limit shall not be reduced.
- For U-NII-2C, the antenna gain is 4.92 dBi < 6 dBi, so the output power limit shall not be reduced.

### 802.11be (EHT20) 26-tone RU

Chan.	Chan. Freq. (MHz)	Average Power (mW)	Average Power (dBm)	Power Limit (dBm)	Test Result
64	5320	32.81	15.16	23.92	Pass
100	5500	32.885	15.17	23.91	Pass
140	5700	33.037	15.19	23.92	Pass

Notes:

- For U-NII-2A, the antenna gain is 4.92 dBi < 6 dBi, so the output power limit shall not be reduced.
- For U-NII-2C, the antenna gain is 4.92 dBi < 6 dBi, so the output power limit shall not be reduced.

### 802.11be (EHT20) 52-tone RU

Chan.	Chan. Freq. (MHz)	Average Power (mW)	Average Power (dBm)	Power Limit (dBm)	Test Result
64	5320	63.68	18.04	23.94	Pass
100	5500	64.565	18.10	23.94	Pass
140	5700	63.241	18.01	23.93	Pass

Notes:

1. For U-NII-2A, the antenna gain is 4.92 dBi < 6 dBi, so the output power limit shall not be reduced.
2. For U-NII-2C, the antenna gain is 4.92 dBi < 6 dBi, so the output power limit shall not be reduced.

### 802.11be (EHT20) 106-tone RU

Chan.	Chan. Freq. (MHz)	Average Power (mW)	Average Power (dBm)	Power Limit (dBm)	Test Result
64	5320	129.718	21.13	24	Pass
100	5500	128.825	21.10	24	Pass
140	5700	89.536	19.52	24	Pass

Notes:

1. For U-NII-2A, the antenna gain is 4.92 dBi < 6 dBi, so the output power limit shall not be reduced.
2. For U-NII-2C, the antenna gain is 4.92 dBi < 6 dBi, so the output power limit shall not be reduced.

### 802.11be (EHT20) 52+26-tone MRU

Chan.	Chan. Freq. (MHz)	Average Power (mW)	Average Power (dBm)	Power Limit (dBm)	Test Result
64	5320	77.625	18.90	23.76	Pass
100	5500	82.224	19.15	23.82	Pass
140	5700	80.353	19.05	23.8	Pass

Notes:

1. For U-NII-2A, the antenna gain is 4.92 dBi < 6 dBi, so the output power limit shall not be reduced.
2. For U-NII-2C, the antenna gain is 4.92 dBi < 6 dBi, so the output power limit shall not be reduced.

### 802.11be (EHT20) 106+26-tone MRU

Chan.	Chan. Freq. (MHz)	Average Power (mW)	Average Power (dBm)	Power Limit (dBm)	Test Result
64	5320	114.025	20.57	24	Pass
100	5500	114.288	20.58	23.92	Pass
140	5700	90.365	19.56	23.94	Pass

Notes:

1. For U-NII-2A, the antenna gain is 4.92 dBi < 6 dBi, so the output power limit shall not be reduced.
2. For U-NII-2C, the antenna gain is 4.92 dBi < 6 dBi, so the output power limit shall not be reduced.

### 802.11be (EHT80) 484+242-tone MRU

Chan.	Chan. Freq. (MHz)	Average Power (mW)	Average Power (dBm)	Power Limit (dBm)	Test Result
58	5290	46.238	16.65	24	Pass
106	5530	40.087	16.03	24	Pass
*138 (U-NII-2C)	5690	72.307	18.59	24	Pass
*138 (U-NII-3)	5690	3.351	5.25	30	Pass

Notes:

- \* : Test was performed in accordance with measurement follow FCC KDB 789033 UNII test procedure Method SA-2 and use spectrum analyzer test , the duty factor was included in the total power.
- For U-NII-2A, the antenna gain is 4.92 dBi < 6 dBi, so the output power limit shall not be reduced.
- For U-NII-2C, the antenna gain is 4.92 dBi < 6 dBi, so the output power limit shall not be reduced.
- For U-NII-3, the antenna gain is 4.92 dBi < 6 dBi, so the output power limit shall not be reduced.

### 802.11be (EHT160) 996+484-tone MRU

Chan.	Chan. Freq. (MHz)	Average Power (mW)	Average Power (dBm)	Power Limit (dBm)	Test Result
*50 (U-NII-1)	5250	7.544	8.78	24	Pass
*50 (U-NII-2A)	5250	3.905	5.92	24	Pass
114	5570	32.509	15.12	24	Pass

Notes:

- \* : Test was performed in accordance with measurement follow FCC KDB 789033 UNII test procedure Method SA-2 and use spectrum analyzer test , the duty factor was included in the total power.
- For U-NII-1, the antenna gain is 4.92 dBi < 6 dBi, so the output power limit shall not be reduced.
- For U-NII-2A, the antenna gain is 4.92 dBi < 6 dBi, so the output power limit shall not be reduced.
- For U-NII-2C, the antenna gain is 4.92 dBi < 6 dBi, so the output power limit shall not be reduced.

### 802.11be (EHT160) 996+484+242-tone MRU

Chan.	Chan. Freq. (MHz)	Average Power (mW)	Average Power (dBm)	Power Limit (dBm)	Test Result
*50 (U-NII-1)	5250	8.121	9.10	24	Pass
*50 (U-NII-2A)	5250	6.881	8.38	24	Pass
114	5570	36.644	15.64	24	Pass

Notes:

- \* : Test was performed in accordance with measurement follow FCC KDB 789033 UNII test procedure Method SA-2 and use spectrum analyzer test , the duty factor was included in the total power.
- For U-NII-1, the antenna gain is 4.92 dBi < 6 dBi, so the output power limit shall not be reduced.
- For U-NII-2A, the antenna gain is 4.92 dBi < 6 dBi, so the output power limit shall not be reduced.
- For U-NII-2C, the antenna gain is 4.92 dBi < 6 dBi, so the output power limit shall not be reduced.



### Spectrum Plot for channel straddling

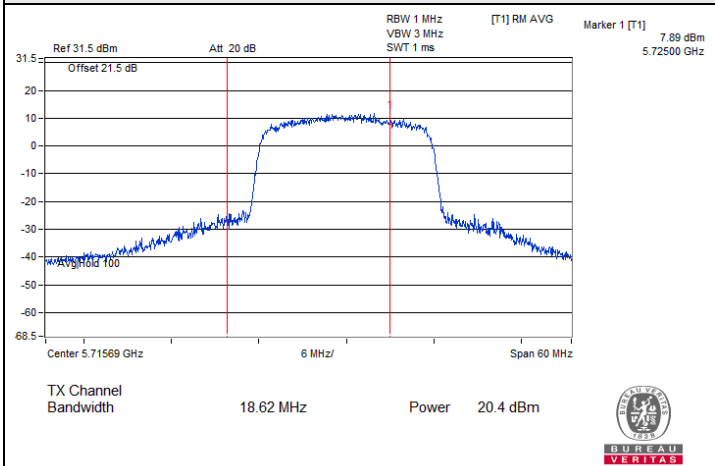

802.11be (EHT20) : CH 144 (U-NII-2C)

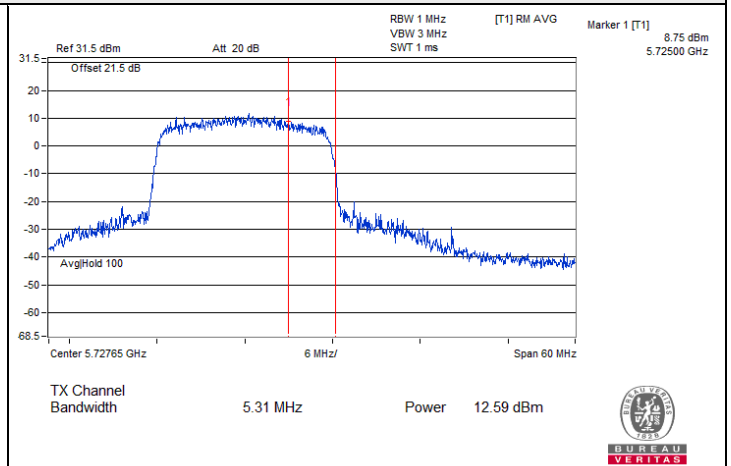

802.11be (EHT20) : CH 144 (U-NII-3)

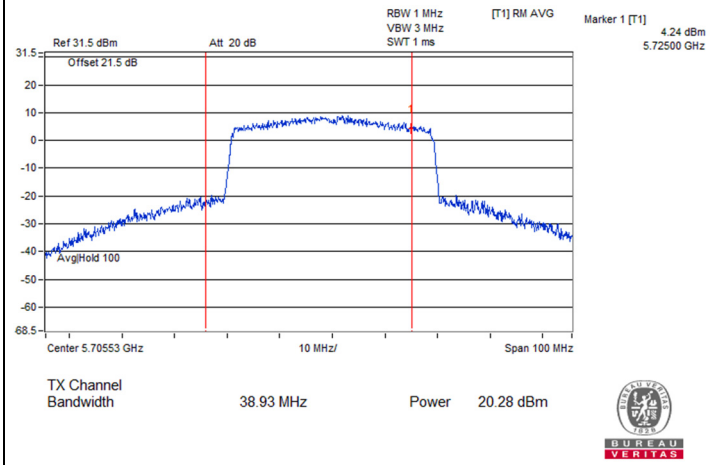

802.11be (EHT40) : CH 142 (U-NII-2C)

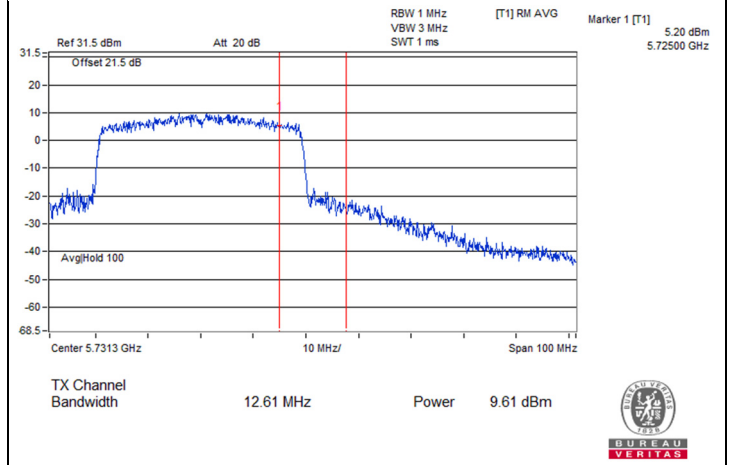

802.11be (EHT40) : CH 142 (U-NII-3)

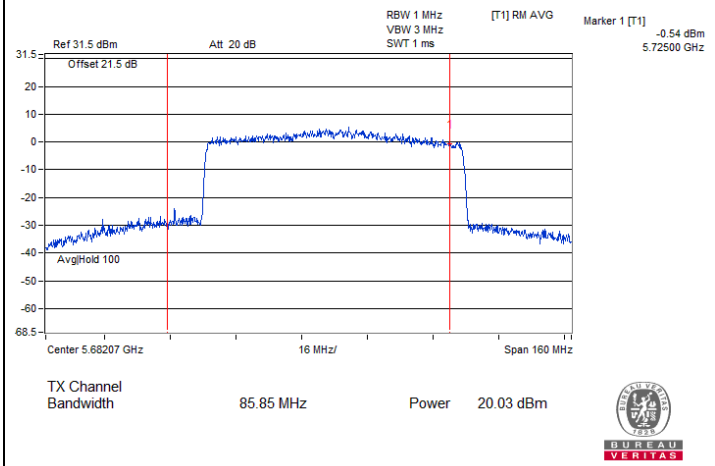

802.11be (EHT80) : CH 138 (U-NII-2C)

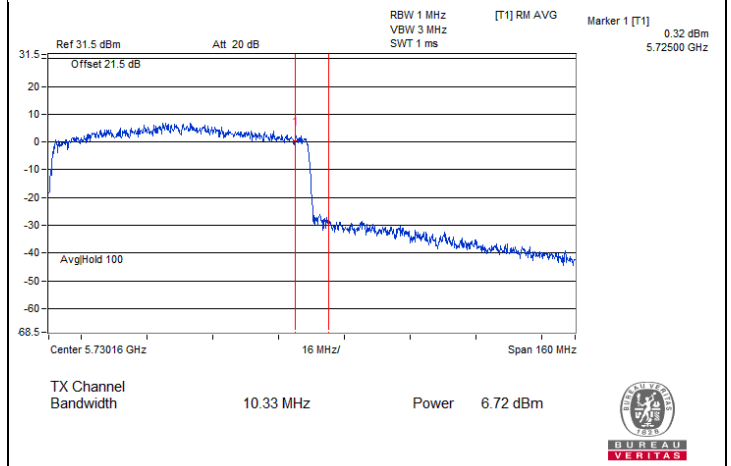

802.11be (EHT80) : CH 138 (U-NII-3)



### Spectrum Plot for channel straddling

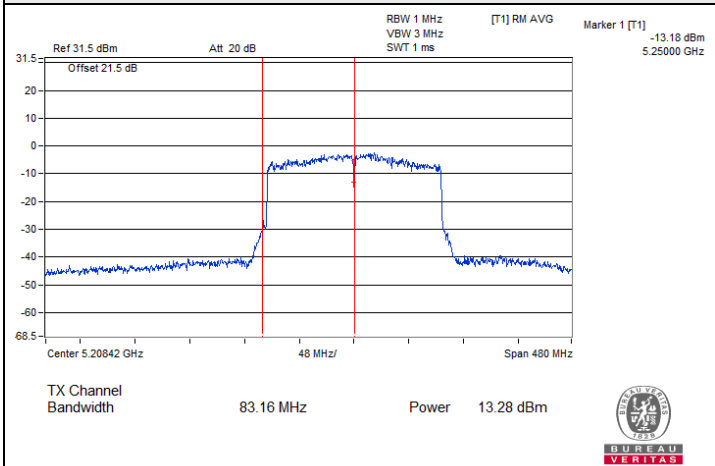

802.11be (EHT160) : CH 50 (U-NII-1)

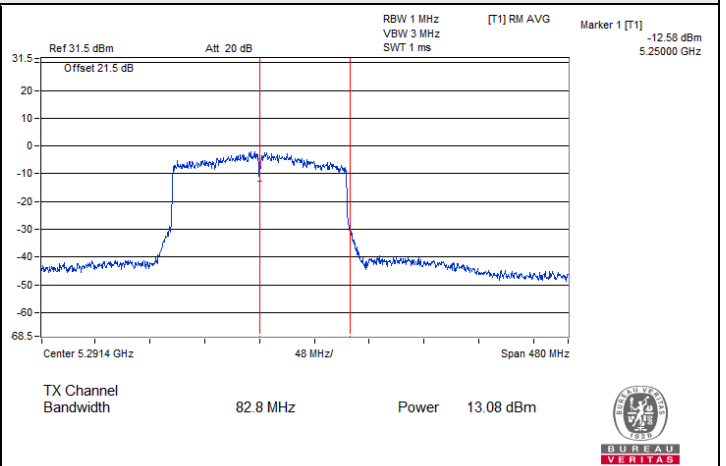

802.11be (EHT160) : CH 50 (U-NII-2A)

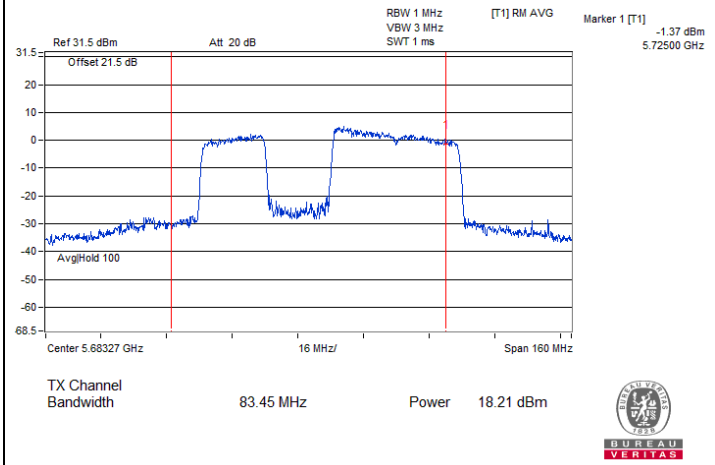

802.11be (EHT80) 484+242-tone MRU : CH 138@91 (U-NII-2C)

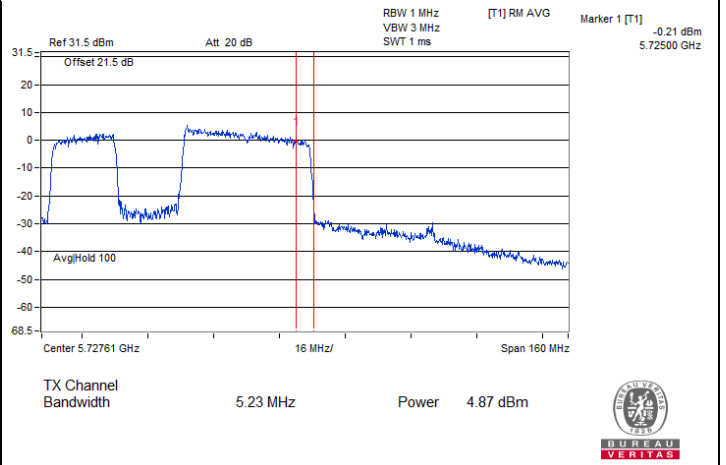

802.11be (EHT80) 484+242-tone MRU : CH 138@91 (U-NII-3)

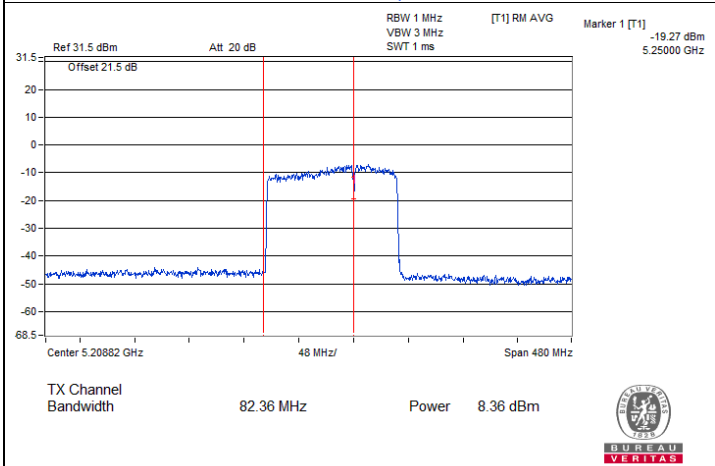

802.11be (EHT160) 996+484-tone MRU : CH 50@95-1 (U-NII-1)

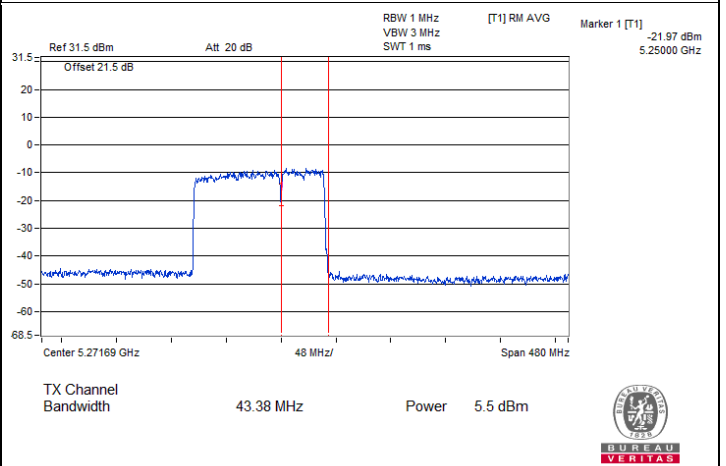

802.11be (EHT160) 996+484-tone MRU : CH 50@95-1 (U-NII-2A)



### Spectrum Plot for channel straddling

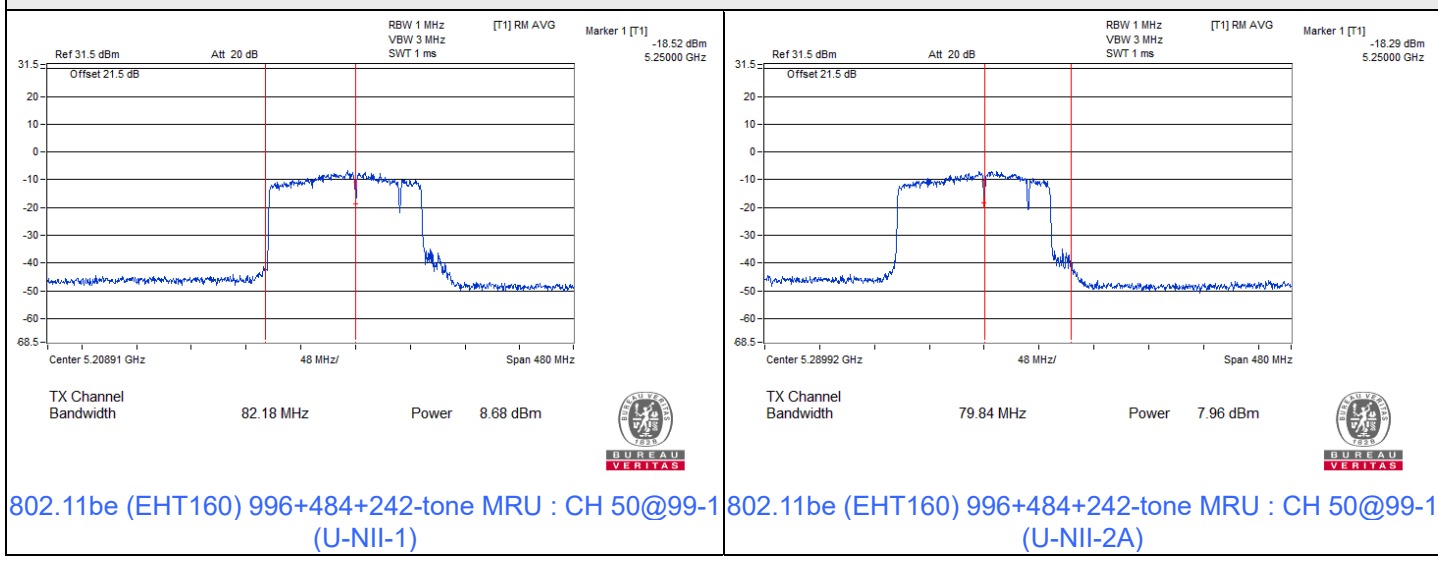



**For 2S2T**
**802.11be (EHT20)**

Chan.	Chan. Freq. (MHz)	Average Power (dBm)		Total Power (mW)	Total Power (dBm)	Power Limit (dBm)	Test Result
		Chain 0	Chain 1				
52	5260	19.77	20.36	203.484	23.09	23.96	Pass
60	5300	19.14	19.82	177.975	22.50	24	Pass
64	5320	19.39	20.15	190.41	22.80	23.99	Pass
100	5500	19.13	20.04	182.772	22.62	24	Pass
116	5580	19.61	20.30	198.563	22.98	23.98	Pass
140	5700	19.45	20.26	194.274	22.88	24	Pass
*144 (U-NII-2C)	5720	15.10	15.54	111.257	20.46	22.74	Pass
*144 (U-NII-3)	5720	9.02	10.10	29.725	14.73	30	Pass

**Notes:**

- \* : Test was performed in accordance with measurement follow FCC KDB 789033 UNII test procedure Method SA-2 and use spectrum analyzer test , the duty factor was included in the total power.
- For U-NII-2A, the directional gain is 4.92 dBi < 6 dBi, so the output power limit shall not be reduced.
- For U-NII-2C, the directional gain is 4.92 dBi < 6 dBi, so the output power limit shall not be reduced.
- For U-NII-3, the directional gain is 4.92 dBi < 6 dBi, so the output power limit shall not be reduced.

**802.11be (EHT40)**

Chan.	Chan. Freq. (MHz)	Average Power (dBm)		Total Power (mW)	Total Power (dBm)	Power Limit (dBm)	Test Result
		Chain 0	Chain 1				
54	5270	20.35	20.52	221.112	23.45	24	Pass
62	5310	18.10	18.30	132.174	21.21	24	Pass
102	5510	18.29	18.62	140.231	21.47	24	Pass
110	5550	19.96	20.34	207.227	23.16	24	Pass
134	5670	20.01	20.27	206.645	23.15	24	Pass
*142 (U-NII-2C)	5710	17.08	17.68	179.634	22.54	24	Pass
*142 (U-NII-3)	5710	6.66	6.74	15.324	11.85	30	Pass

**Notes:**

- \* : Test was performed in accordance with measurement follow FCC KDB 789033 UNII test procedure Method SA-2 and use spectrum analyzer test , the duty factor was included in the total power.
- For U-NII-2A, the directional gain is 4.92 dBi < 6 dBi, so the output power limit shall not be reduced.
- For U-NII-2C, the directional gain is 4.92 dBi < 6 dBi, so the output power limit shall not be reduced.
- For U-NII-3, the directional gain is 4.92 dBi < 6 dBi, so the output power limit shall not be reduced.

### 802.11be (EHT80)

Chan.	Chan. Freq. (MHz)	Average Power (dBm)		Total Power (mW)	Total Power (dBm)	Power Limit (dBm)	Test Result
		Chain 0	Chain 1				
58	5290	16.81	17.01	98.208	19.92	24	Pass
106	5530	17.17	17.57	109.267	20.38	24	Pass
122	5610	19.85	20.06	197.996	22.97	24	Pass
*138 (U-NII-2C)	5690	17.13	18.11	196.077	22.92	24	Pass
*138 (U-NII-3)	5690	1.89	4.55	7.408	8.70	30	Pass

Notes:

- \* : Test was performed in accordance with measurement follow FCC KDB 789033 UNII test procedure Method SA-2 and use spectrum analyzer test , the duty factor was included in the total power.
- For U-NII-2A, the directional gain is 4.92 dBi < 6 dBi, so the output power limit shall not be reduced.
- For U-NII-2C, the directional gain is 4.92 dBi < 6 dBi, so the output power limit shall not be reduced.
- For U-NII-3, the directional gain is 4.92 dBi < 6 dBi, so the output power limit shall not be reduced.

### 802.11be (EHT160)

Chan.	Chan. Freq. (MHz)	Average Power (dBm)		Total Power (mW)	Total Power (dBm)	Power Limit (dBm)	Test Result
		Chain 0	Chain 1				
*50 (U-NII-1)	5250	8.54	9.20	23.715	13.75	24	Pass
*50 (U-NII-2A)	5250	9.68	8.53	25.18	14.01	24	Pass
114	5570	16.06	16.26	82.631	19.17	24	Pass

Notes:

- \* : Test was performed in accordance with measurement follow FCC KDB 789033 UNII test procedure Method SA-2 and use spectrum analyzer test , the duty factor was included in the total power.
- For U-NII-1, the directional gain is 4.92 dBi < 6 dBi, so the output power limit shall not be reduced.
- For U-NII-2A, the directional gain is 4.92 dBi < 6 dBi, so the output power limit shall not be reduced.
- For U-NII-2C, the directional gain is 4.92 dBi < 6 dBi, so the output power limit shall not be reduced.

### 802.11be (EHT20) 26-tone RU

Chan.	Chan. Freq. (MHz)	Average Power (dBm)		Total Power (mW)	Total Power (dBm)	Power Limit (dBm)	Test Result
		Chain 0	Chain 1				
64	5320	12.05	12.15	32.438	15.11	23.9	Pass
100	5500	12.09	12.20	32.777	15.16	23.89	Pass
140	5700	12.10	12.15	32.624	15.14	23.91	Pass

Notes:

- For U-NII-2A, the directional gain is 4.92 dBi < 6 dBi, so the output power limit shall not be reduced.
- For U-NII-2C, the directional gain is 4.92 dBi < 6 dBi, so the output power limit shall not be reduced.

### 802.11be (EHT20) 52-tone RU

Chan.	Chan. Freq. (MHz)	Average Power (dBm)		Total Power (mW)	Total Power (dBm)	Power Limit (dBm)	Test Result
		Chain 0	Chain 1				
64	5320	15.06	15.20	65.176	18.14	23.9	Pass
100	5500	15.03	15.31	65.805	18.18	23.93	Pass
140	5700	15.07	15.26	65.71	18.18	23.91	Pass

Notes:

1. For U-NII-2A, the directional gain is 4.92 dBi < 6 dBi, so the output power limit shall not be reduced.
2. For U-NII-2C, the directional gain is 4.92 dBi < 6 dBi, so the output power limit shall not be reduced.

### 802.11be (EHT20) 106-tone RU

Chan.	Chan. Freq. (MHz)	Average Power (dBm)		Total Power (mW)	Total Power (dBm)	Power Limit (dBm)	Test Result
		Chain 0	Chain 1				
64	5320	18.03	18.10	128.099	21.08	24	Pass
100	5500	18.05	18.21	130.048	21.14	23.96	Pass
140	5700	18.01	18.31	131.005	21.17	23.91	Pass

Notes:

1. For U-NII-2A, the directional gain is 4.92 dBi < 6 dBi, so the output power limit shall not be reduced.
2. For U-NII-2C, the directional gain is 4.92 dBi < 6 dBi, so the output power limit shall not be reduced.

### 802.11be (EHT20) 52+26-tone MRU

Chan.	Chan. Freq. (MHz)	Average Power (dBm)		Total Power (mW)	Total Power (dBm)	Power Limit (dBm)	Test Result
		Chain 0	Chain 1				
64	5320	16.75	17.00	97.434	19.89	23.8	Pass
100	5500	16.87	16.83	96.836	19.86	23.72	Pass
140	5700	16.76	16.94	96.855	19.86	23.79	Pass

Notes:

1. For U-NII-2A, the directional gain is 4.92 dBi < 6 dBi, so the output power limit shall not be reduced.
2. For U-NII-2C, the directional gain is 4.92 dBi < 6 dBi, so the output power limit shall not be reduced.

### 802.11be (EHT20) 106+26-tone MRU

Chan.	Chan. Freq. (MHz)	Average Power (dBm)		Total Power (mW)	Total Power (dBm)	Power Limit (dBm)	Test Result
		Chain 0	Chain 1				
64	5320	17.92	18.24	128.625	21.09	23.9	Pass
100	5500	17.96	18.21	128.739	21.10	23.88	Pass
140	5700	17.90	18.14	126.822	21.03	23.9	Pass

Notes:

1. For U-NII-2A, the directional gain is 4.92 dBi < 6 dBi, so the output power limit shall not be reduced.
2. For U-NII-2C, the directional gain is 4.92 dBi < 6 dBi, so the output power limit shall not be reduced.

### 802.11be (EHT80) 484+242-tone MRU

Chan.	Chan. Freq. (MHz)	Average Power (dBm)		Total Power (mW)	Total Power (dBm)	Power Limit (dBm)	Test Result
		Chain 0	Chain 1				
58	5290	14.11	14.44	53.56	17.29	24	Pass
106	5530	15.05	15.23	65.332	18.15	24	Pass
*138 (U-NII-2C)	5690	19.33	19.38	201.089	23.03	24	Pass
*138 (U-NII-3)	5690	6.18	6.12	9.614	9.83	30	Pass

**Notes:**

- \* : Test was performed in accordance with measurement follow FCC KDB 789033 UNII test procedure Method SA-2 and use spectrum analyzer test , the duty factor was included in the total power.
- For U-NII-2A, the directional gain is 4.92 dBi < 6 dBi, so the output power limit shall not be reduced.
- For U-NII-2C, the directional gain is 4.92 dBi < 6 dBi, so the output power limit shall not be reduced.
- For U-NII-3, the directional gain is 4.92 dBi < 6 dBi, so the output power limit shall not be reduced.

### 802.11be (EHT160) 996+484-tone MRU

Chan.	Chan. Freq. (MHz)	Average Power (dBm)		Total Power (mW)	Total Power (dBm)	Power Limit (dBm)	Test Result
		Chain 0	Chain 1				
*50 (U-NII-1)	5250	9.87	10.19	23.585	13.73	24	Pass
*50 (U-NII-2A)	5250	7.72	7.64	13.72	11.37	24	Pass
114	5570	13.58	13.71	46.3	16.66	24	Pass

**Notes:**

- \* : Test was performed in accordance with measurement follow FCC KDB 789033 UNII test procedure Method SA-2 and use spectrum analyzer test , the duty factor was included in the total power.
- For U-NII-1, the directional gain is 4.92 dBi < 6 dBi, so the output power limit shall not be reduced.
- For U-NII-2A, the directional gain is 4.92 dBi < 6 dBi, so the output power limit shall not be reduced.
- For U-NII-2C, the directional gain is 4.92 dBi < 6 dBi, so the output power limit shall not be reduced.

### 802.11be (EHT160) 996+484+242-tone MRU

Chan.	Chan. Freq. (MHz)	Average Power (dBm)		Total Power (mW)	Total Power (dBm)	Power Limit (dBm)	Test Result
		Chain 0	Chain 1				
*50 (U-NII-1)	5250	9.11	9.67	20.382	13.09	24	Pass
*50 (U-NII-2A)	5250	7.95	7.86	14.45	11.60	24	Pass
114	5570	14.23	14.31	53.462	17.28	24	Pass

**Notes:**

- \* : Test was performed in accordance with measurement follow FCC KDB 789033 UNII test procedure Method SA-2 and use spectrum analyzer test , the duty factor was included in the total power.
- For U-NII-1, the directional gain is 4.92 dBi < 6 dBi, so the output power limit shall not be reduced.
- For U-NII-2A, the directional gain is 4.92 dBi < 6 dBi, so the output power limit shall not be reduced.
- For U-NII-2C, the directional gain is 4.92 dBi < 6 dBi, so the output power limit shall not be reduced.



### Spectrum Plot for channel straddling

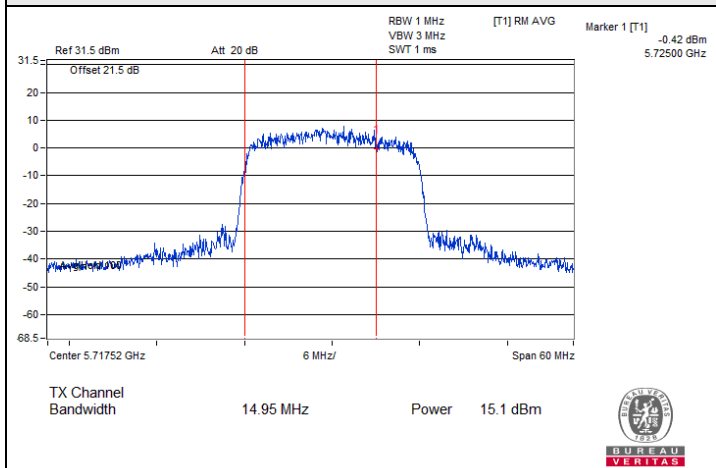

802.11be (EHT20) / Chain 0 : CH 144 (U-NII-2C)

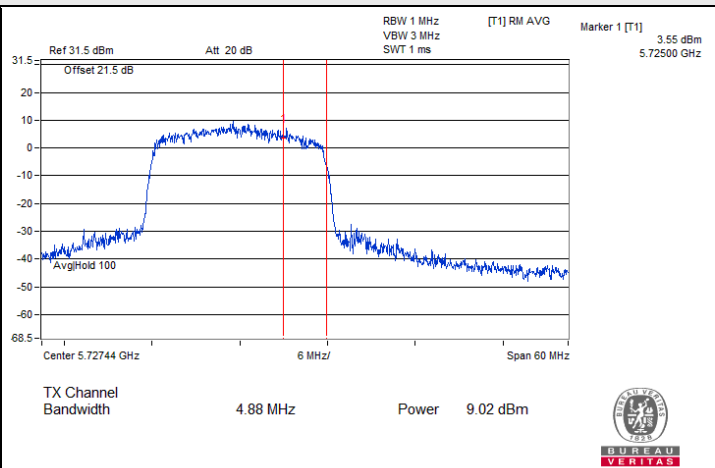

802.11be (EHT20) / Chain 0 : CH 144 (U-NII-3)

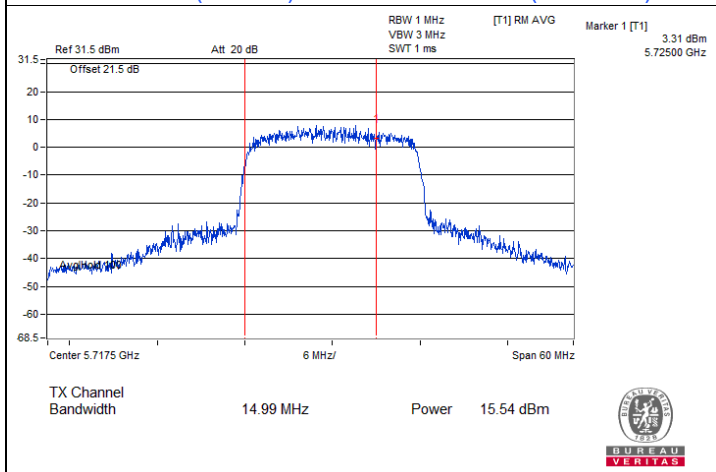

802.11be (EHT20) / Chain 1 : CH 144 (U-NII-2C)

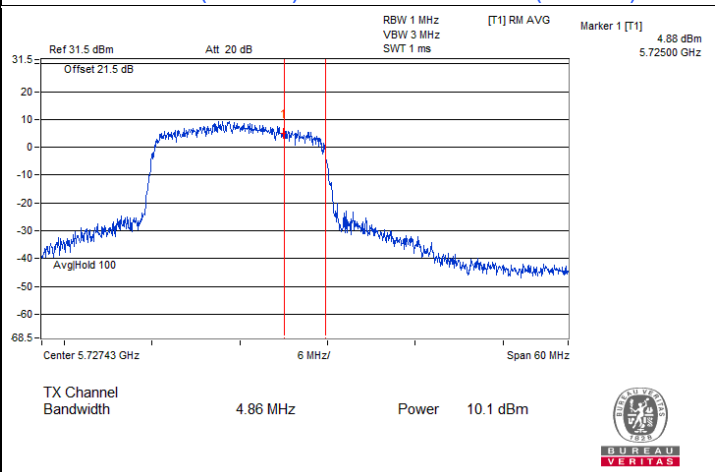

802.11be (EHT20) / Chain 1 : CH 144 (U-NII-3)

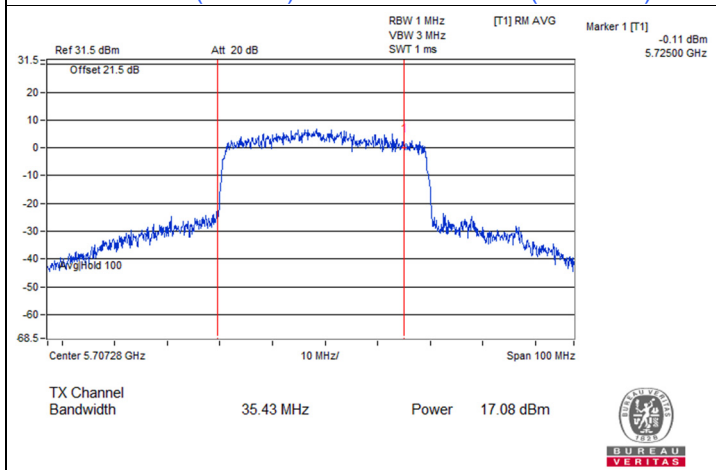

802.11be (EHT40) / Chain 0 : CH 142 (U-NII-2C)

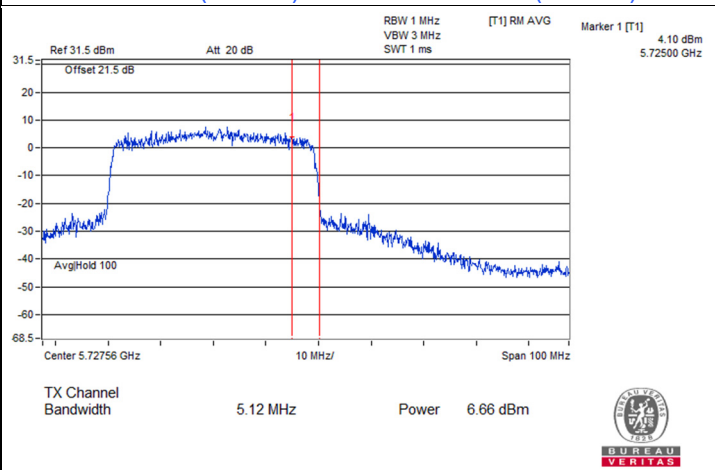

802.11be (EHT40) / Chain 0 : CH 142 (U-NII-3)



### Spectrum Plot for channel straddling

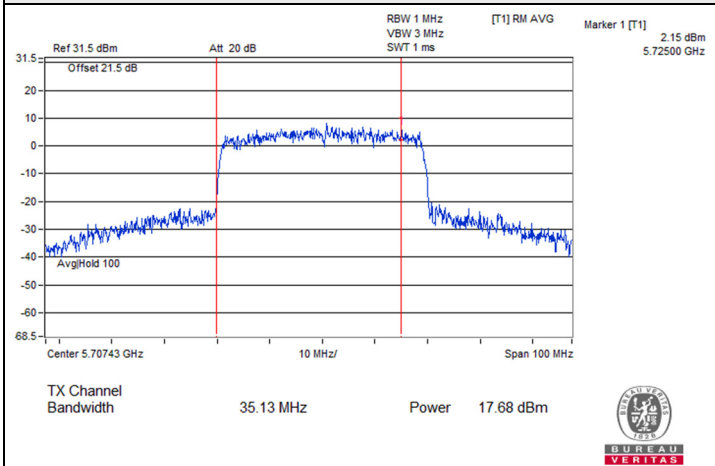

802.11be (EHT40) / Chain 1 : CH 142 (U-NII-2C)

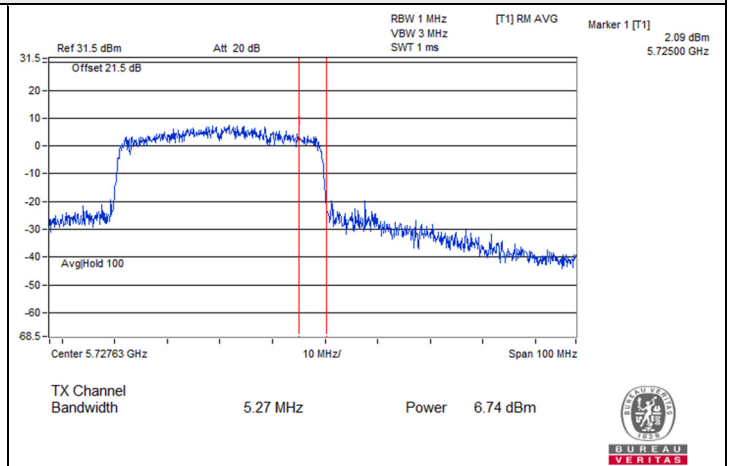

802.11be (EHT40) / Chain 1 : CH 142 (U-NII-3)

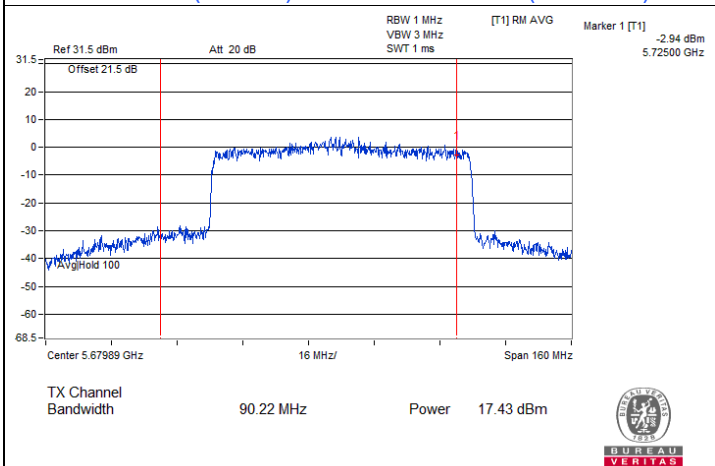

802.11be (EHT80) / Chain 0 : CH 138 (U-NII-2C)

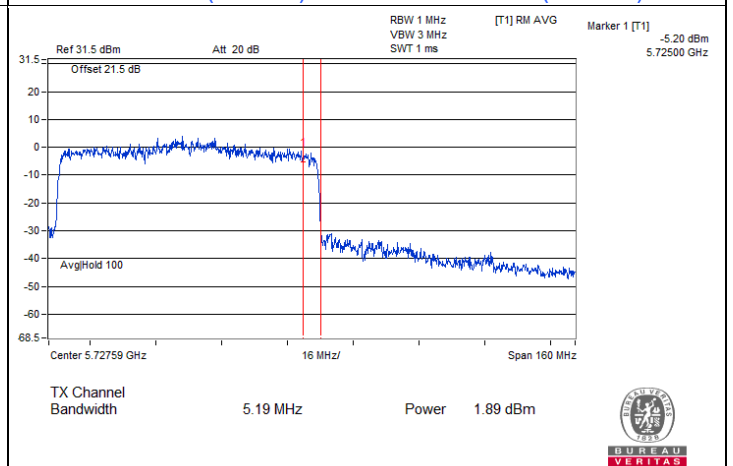

802.11be (EHT80) / Chain 0 : CH 138 (U-NII-3)

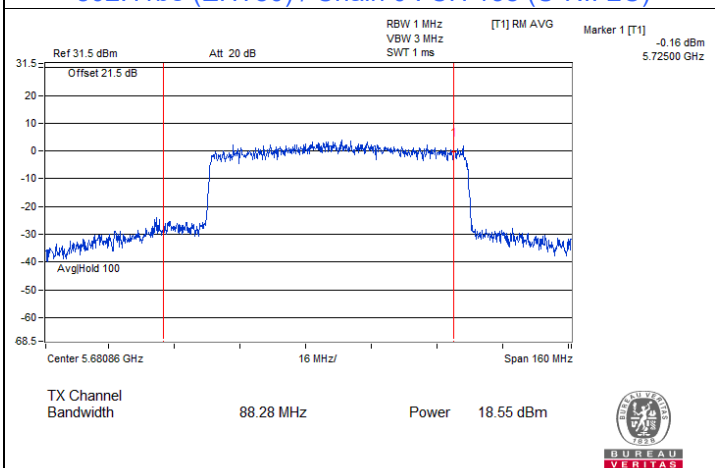

802.11be (EHT80) / Chain 1 : CH 138 (U-NII-2C)

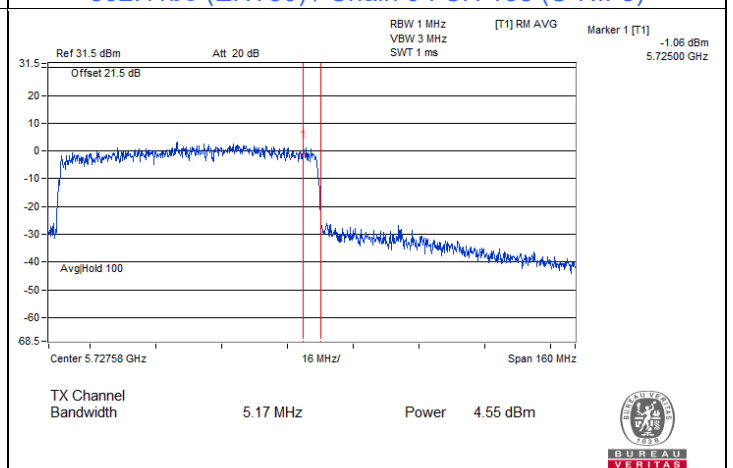

802.11be (EHT80) / Chain 1 : CH 138 (U-NII-3)

### Spectrum Plot for channel straddling

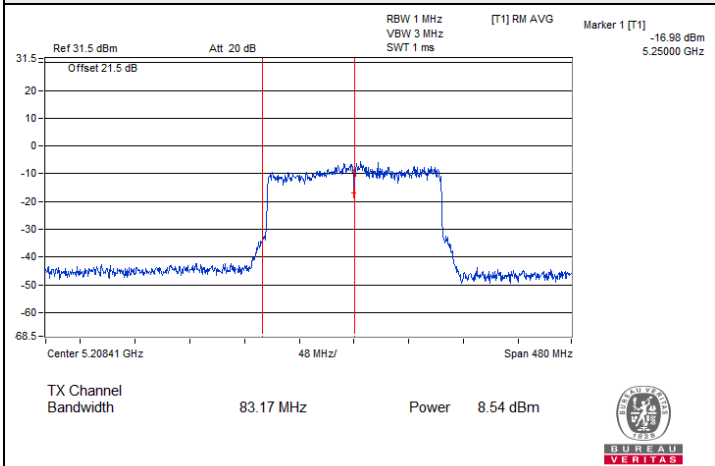

802.11be (EHT160) / Chain 0 : CH 50 (U-NII-1)

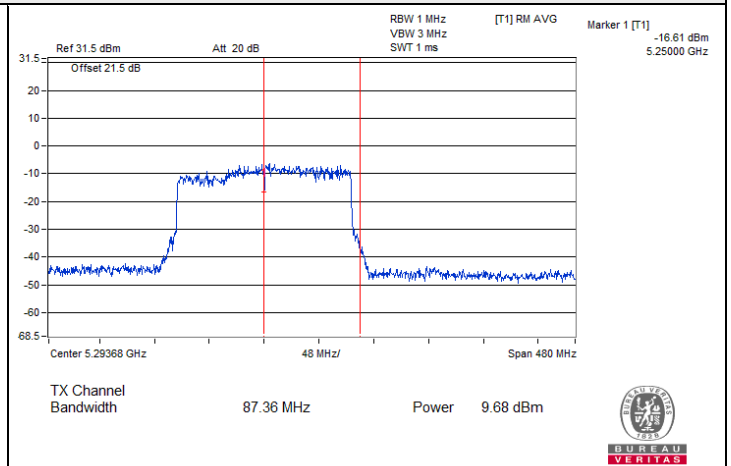

802.11be (EHT160) / Chain 0 : CH 50 (U-NII-2A)

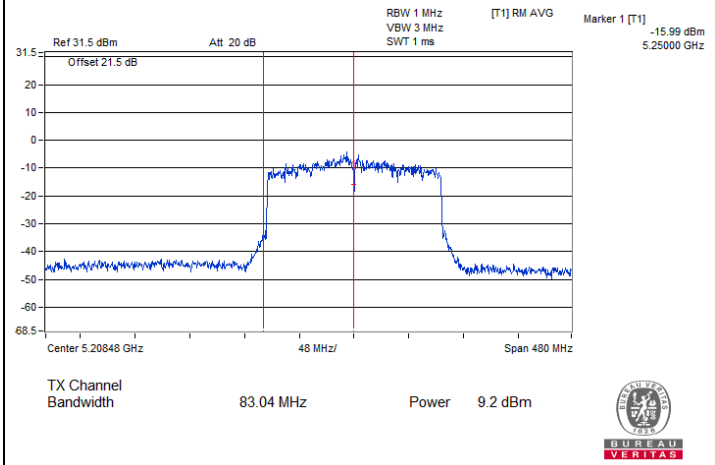

802.11be (EHT160) / Chain 1 : CH 50 (U-NII-1)

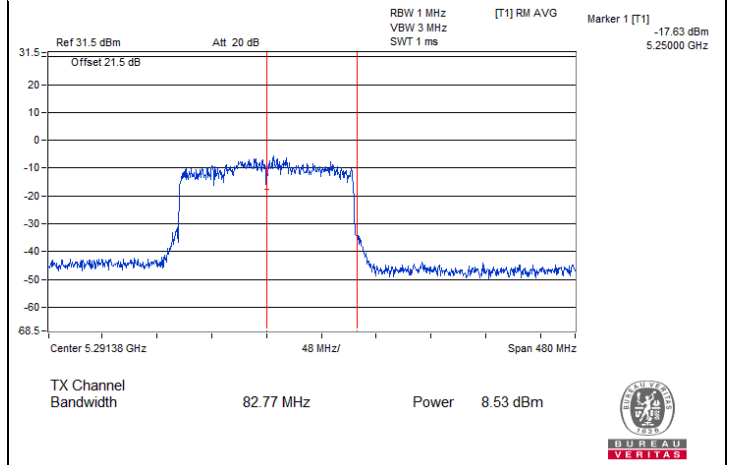

802.11be (EHT160) / Chain 1 : CH 50 (U-NII-2A)

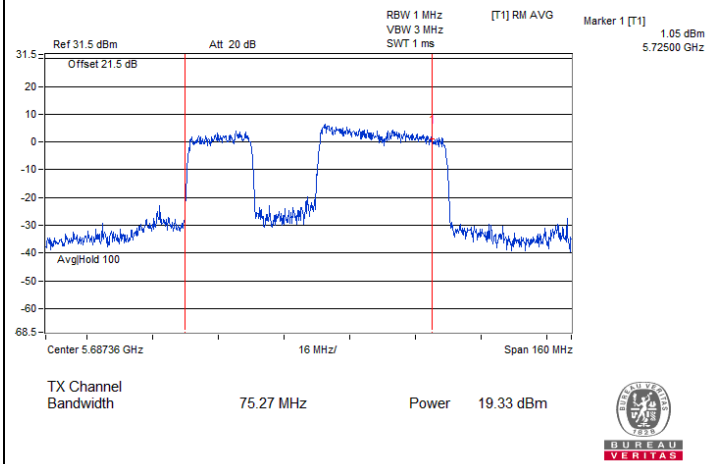

802.11be (EHT80) 484+242-tone MRU / Chain 0 : CH 138@91 (U-NII-2C)

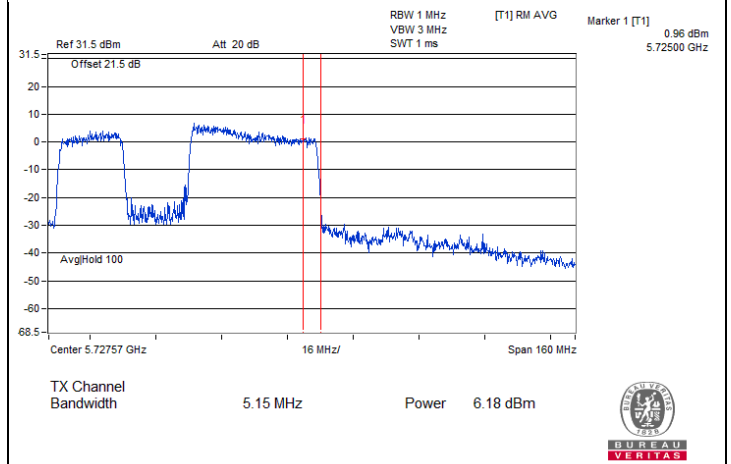

802.11be (EHT80) 484+242-tone MRU / Chain 0 : CH 138@91 (U-NII-3)



### Spectrum Plot for channel straddling

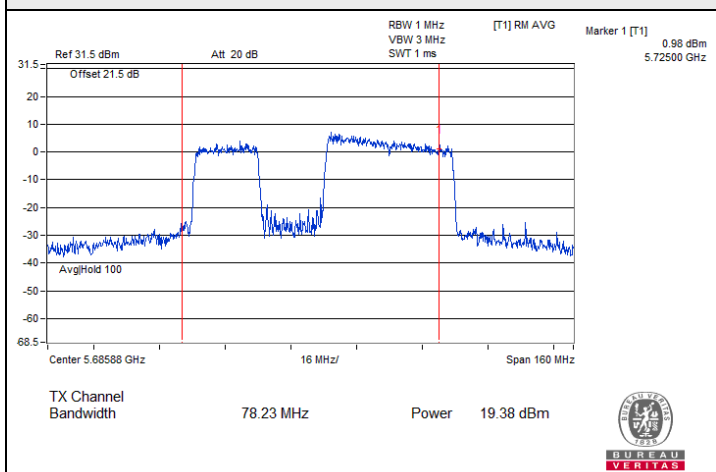

802.11be (EHT80) 484+242-tone MRU / Chain 1 : CH 138@91 (U-NII-2C)

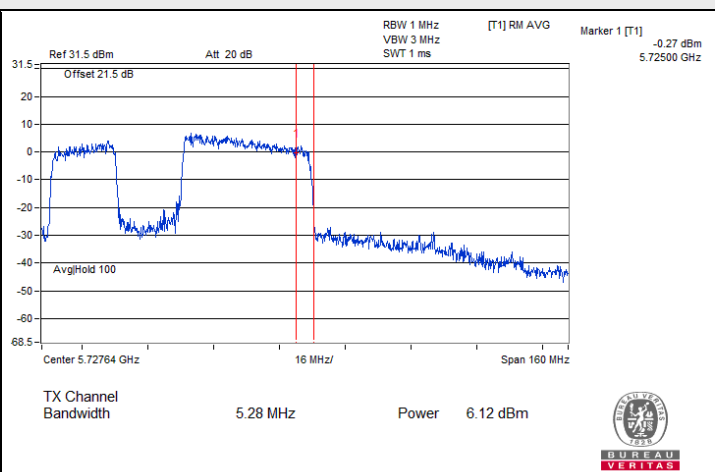

802.11be (EHT80) 484+242-tone MRU / Chain 1 : CH 138@91 (U-NII-3)

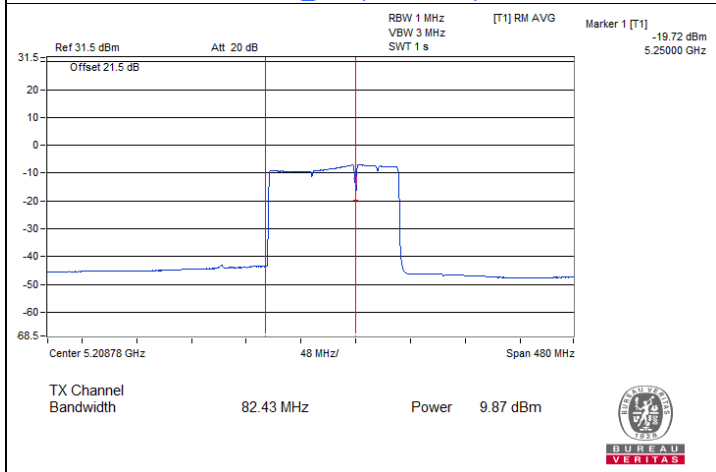

802.11be (EHT160) 996+484-tone MRU / Chain 0 : CH 50@95-1 (U-NII-1)

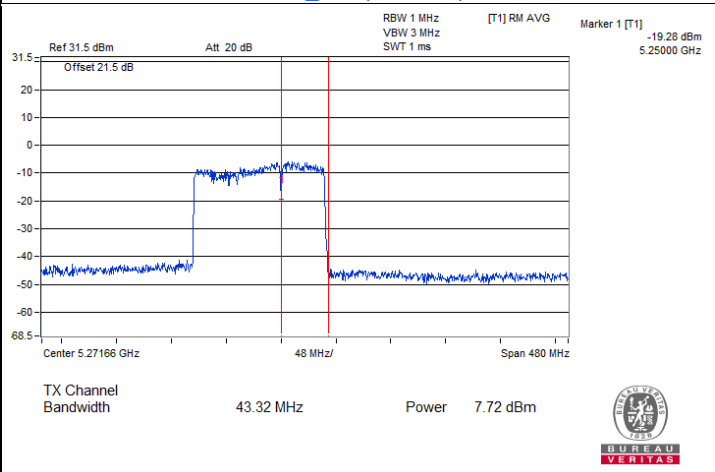

802.11be (EHT160) 996+484-tone MRU / Chain 0 : CH 50@95-1 (U-NII-2A)

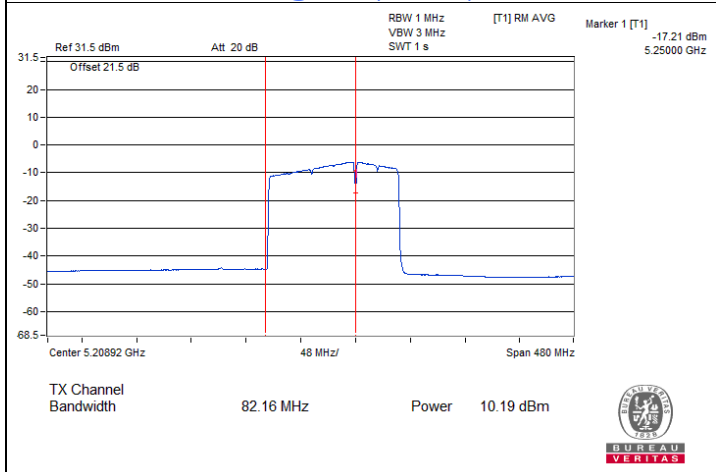

802.11be (EHT160) 996+484-tone MRU / Chain 1 : CH 50@95-1 (U-NII-1)

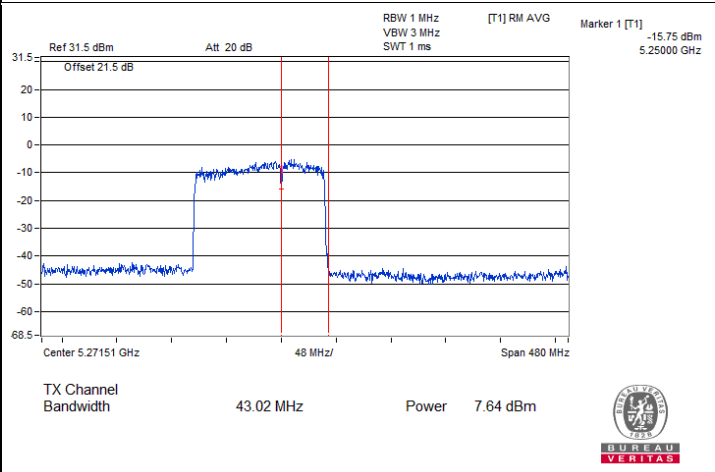

802.11be (EHT160) 996+484-tone MRU / Chain 1 : CH 50@95-1 (U-NII-2A)



### Spectrum Plot for channel straddling

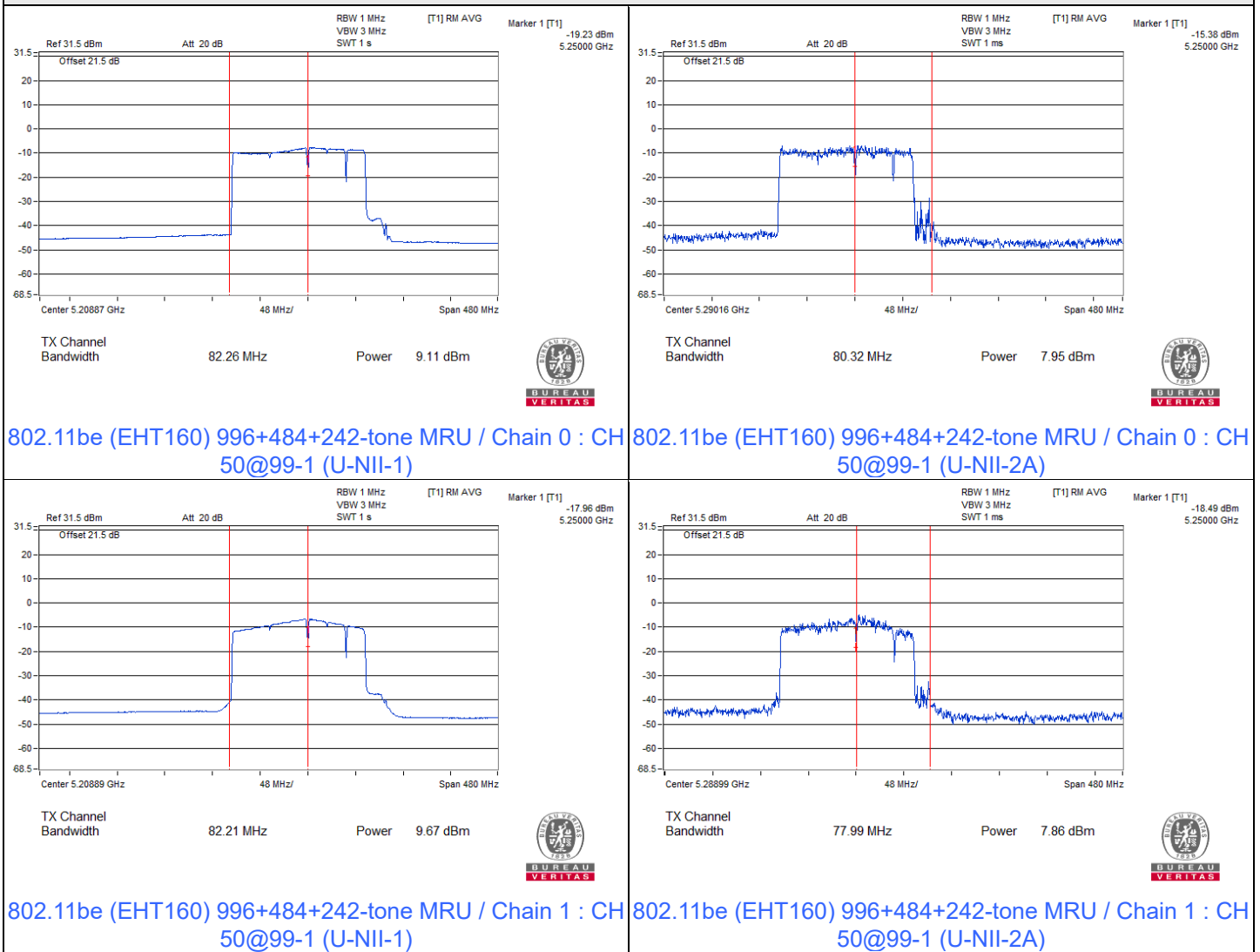

### 7.3 Power Spectral Density

Input Power:	3.3 Vdc	Environmental Conditions:	25°C, 60% RH	Tested By:	Willy Lin
--------------	---------	---------------------------	--------------	------------	-----------

#### For 1S1T

#### 802.11be (EHT20)

Chan.	Chan. Freq. (MHz)	PSD w/o Duty Factor (dBm/MHz)	Duty Factor (dB)	PSD (dBm/MHz)	Max. PSD Limit (dBm/MHz)	Test Result
52	5260	8.38	1.21	9.59	11	Pass
60	5300	8.04	1.21	9.25	11	Pass
64	5320	8.07	1.21	9.28	11	Pass
100	5500	8.12	1.21	9.33	11	Pass
116	5580	8.44	1.21	9.65	11	Pass
140	5700	9.27	1.21	10.48	11	Pass
144 (U-NII-2C)	5720	8.31	1.21	9.52	11	Pass

#### Notes:

1. For U-NII-2A, the antenna gain is 4.92 dBi < 6 dBi, so the power density limit shall not be reduced.
2. For U-NII-2C, the antenna gain is 4.92 dBi < 6 dBi, so the power density limit shall not be reduced.

#### 802.11be (EHT40)

Chan.	Chan. Freq. (MHz)	PSD w/o Duty Factor (dBm/MHz)	Duty Factor (dB)	PSD (dBm/MHz)	Max. PSD Limit (dBm/MHz)	Test Result
54	5270	5.82	1.23	7.05	11	Pass
62	5310	3.16	1.23	4.39	11	Pass
102	5510	2.87	1.23	4.10	11	Pass
110	5550	6.25	1.23	7.48	11	Pass
134	5670	4.92	1.23	6.15	11	Pass
142 (U-NII-2C)	5710	6.45	1.23	7.68	11	Pass

#### Notes:

1. For U-NII-2A, the antenna gain is 4.92 dBi < 6 dBi, so the power density limit shall not be reduced.
2. For U-NII-2C, the antenna gain is 4.92 dBi < 6 dBi, so the power density limit shall not be reduced.

### 802.11be (EHT80)

Chan.	Chan. Freq. (MHz)	PSD w/o Duty Factor (dBm/MHz)	Duty Factor (dB)	PSD (dBm/MHz)	Max. PSD Limit (dBm/MHz)	Test Result
58	5290	-0.73	1.30	0.57	11	Pass
106	5530	-0.66	1.30	0.64	11	Pass
122	5610	1.97	1.30	3.27	11	Pass
138 (U-NII-2C)	5690	2.82	1.30	4.12	11	Pass

Notes:

1. For U-NII-2A, the antenna gain is 4.92 dBi < 6 dBi, so the power density limit shall not be reduced.
2. For U-NII-2C, the antenna gain is 4.92 dBi < 6 dBi, so the power density limit shall not be reduced.

### 802.11be (EHT160)

Chan.	Chan. Freq. (MHz)	PSD w/o Duty Factor (dBm/MHz)	Duty Factor (dB)	PSD (dBm/MHz)	Max. PSD Limit (dBm/MHz)	Test Result
50 (U-NII-1)	5250	-6.14	1.12	-5.02	11	Pass
50 (U-NII-2A)	5250	-6.06	1.12	-4.94	11	Pass
114	5570	-4.92	1.12	-3.80	11	Pass

Notes:

1. For U-NII-1, the antenna gain is 4.92 dBi < 6dBi, so the power density limit shall not be reduced.
2. For U-NII-2A, the antenna gain is 4.92 dBi < 6 dBi, so the power density limit shall not be reduced.
3. For U-NII-2C, the antenna gain is 4.92 dBi < 6 dBi, so the power density limit shall not be reduced.

### 802.11be (EHT20) 26-tone RU

Chan.	Chan. Freq. (MHz)	PSD w/o Duty Factor (dBm/MHz)	Duty Factor (dB)	PSD (dBm/MHz)	Max. PSD Limit (dBm/MHz)	Test Result
64	5320	10.65	0.32	10.97	11	Pass
100	5500	10.66	0.32	10.98	11	Pass
140	5700	10.53	0.32	10.85	11	Pass

Notes:

1. For U-NII-2A, the antenna gain is 4.92 dBi < 6 dBi, so the power density limit shall not be reduced.
2. For U-NII-2C, the antenna gain is 4.92 dBi < 6 dBi, so the power density limit shall not be reduced.

### 802.11be (EHT20) 52-tone RU

Chan.	Chan. Freq. (MHz)	PSD w/o Duty Factor (dBm/MHz)	Duty Factor (dB)	PSD (dBm/MHz)	Max. PSD Limit (dBm/MHz)	Test Result
64	5320	10.48	0.32	10.80	11	Pass
100	5500	10.53	0.32	10.85	11	Pass
140	5700	10.52	0.32	10.84	11	Pass

Notes:

1. For U-NII-2A, the antenna gain is 4.92 dBi < 6 dBi, so the power density limit shall not be reduced.
2. For U-NII-2C, the antenna gain is 4.92 dBi < 6 dBi, so the power density limit shall not be reduced.

### 802.11be (EHT20) 106-tone RU

Chan.	Chan. Freq. (MHz)	PSD w/o Duty Factor (dBm/MHz)	Duty Factor (dB)	PSD (dBm/MHz)	Max. PSD Limit (dBm/MHz)	Test Result
64	5320	10.52	0.33	10.85	11	Pass
100	5500	10.49	0.33	10.82	11	Pass
140	5700	9.06	0.33	9.39	11	Pass

Notes:

1. For U-NII-2A, the antenna gain is 4.92 dBi < 6 dBi, so the power density limit shall not be reduced.
2. For U-NII-2C, the antenna gain is 4.92 dBi < 6 dBi, so the power density limit shall not be reduced.

### 802.11be (EHT20) 52+26-tone MRU

Chan.	Chan. Freq. (MHz)	PSD w/o Duty Factor (dBm/MHz)	Duty Factor (dB)	PSD (dBm/MHz)	Max. PSD Limit (dBm/MHz)	Test Result
64	5320	10.12	0.36	10.48	11	Pass
100	5500	9.84	0.36	10.20	11	Pass
140	5700	10.10	0.36	10.46	11	Pass

Notes:

1. For U-NII-2A, the antenna gain is 4.92 dBi < 6 dBi, so the power density limit shall not be reduced.
2. For U-NII-2C, the antenna gain is 4.92 dBi < 6 dBi, so the power density limit shall not be reduced.

### 802.11be (EHT20) 106+26-tone MRU

Chan.	Chan. Freq. (MHz)	PSD w/o Duty Factor (dBm/MHz)	Duty Factor (dB)	PSD (dBm/MHz)	Max. PSD Limit (dBm/MHz)	Test Result
64	5320	10.59	0.36	10.95	11	Pass
100	5500	10.57	0.36	10.93	11	Pass
140	5700	10.57	0.36	10.93	11	Pass

Notes:

1. For U-NII-2A, the antenna gain is 4.92 dBi < 6 dBi, so the power density limit shall not be reduced.
2. For U-NII-2C, the antenna gain is 4.92 dBi < 6 dBi, so the power density limit shall not be reduced.

### 802.11be (EHT80) 484+242-tone MRU

Chan.	Chan. Freq. (MHz)	PSD w/o Duty Factor (dBm/MHz)	Duty Factor (dB)	PSD (dBm/MHz)	Max. PSD Limit (dBm/MHz)	Test Result
58	5290	-7.47	0.38	-7.09	11	Pass
106	5530	-5.90	0.38	-5.52	11	Pass
138 (U-NII-2C)	5690	-2.63	0.38	-2.25	11	Pass

Notes:

1. For U-NII-2A, the antenna gain is 4.92 dBi < 6 dBi, so the power density limit shall not be reduced.
2. For U-NII-2C, the antenna gain is 4.92 dBi < 6 dBi, so the power density limit shall not be reduced.

### 802.11be (EHT160) 996+484-tone MRU

Chan.	Chan. Freq. (MHz)	PSD w/o Duty Factor (dBm/MHz)	Duty Factor (dB)	PSD (dBm/MHz)	Max. PSD Limit (dBm/MHz)	Test Result
50 (U-NII-1)	5250	-11.97	0.42	-11.55	11	Pass
50 (U-NII-2A)	5250	-11.58	0.42	-11.16	11	Pass
114	5570	-8.97	0.42	-8.55	11	Pass

**Notes:**

1. For U-NII-1, the antenna gain is 4.92 dBi < 6dBi, so the power density limit shall not be reduced.
2. For U-NII-2A, the antenna gain is 4.92 dBi < 6 dBi, so the power density limit shall not be reduced.
3. For U-NII-2C, the antenna gain is 4.92 dBi < 6 dBi, so the power density limit shall not be reduced.

### 802.11be (EHT160) 996+484+242-tone MRU

Chan.	Chan. Freq. (MHz)	PSD w/o Duty Factor (dBm/MHz)	Duty Factor (dB)	PSD (dBm/MHz)	Max. PSD Limit (dBm/MHz)	Test Result
50 (U-NII-1)	5250	-12.60	0.42	-12.18	11	Pass
50 (U-NII-2A)	5250	-12.43	0.42	-12.01	11	Pass
114	5570	-10.44	0.42	-10.02	11	Pass

**Notes:**

1. For U-NII-1, the antenna gain is 4.92 dBi < 6dBi, so the power density limit shall not be reduced.
2. For U-NII-2A, the antenna gain is 4.92 dBi < 6 dBi, so the power density limit shall not be reduced.
3. For U-NII-2C, the antenna gain is 4.92 dBi < 6 dBi, so the power density limit shall not be reduced.

### 802.11be (EHT20)

Chan.	Chan. Freq. (MHz)	PSD w/o Duty Factor (dBm/300kHz)	Duty Factor (dB)	PSD (dBm/500kHz)	PSD Limit (dBm/500kHz)	Test Result
144 (U-NII-3)	5720	0.83	1.21	4.26	30	Pass

Note: For U-NII-3, the antenna gain is 4.92 dBi < 6 dBi, so the power density limit shall not be reduced.

### 802.11be (EHT40)

Chan.	Chan. Freq. (MHz)	PSD w/o Duty Factor (dBm/300kHz)	Duty Factor (dB)	PSD (dBm/500kHz)	PSD Limit (dBm/500kHz)	Test Result
142 (U-NII-3)	5710	-2.66	1.23	0.79	30	Pass

Note: For U-NII-3, the antenna gain is 4.92 dBi < 6 dBi, so the power density limit shall not be reduced.

### 802.11be (EHT80)

Chan.	Chan. Freq. (MHz)	PSD w/o Duty Factor (dBm/300kHz)	Duty Factor (dB)	PSD (dBm/500kHz)	PSD Limit (dBm/500kHz)	Test Result
138 (U-NII-3)	5690	-6.27	1.3	-2.75	30	Pass

Note: For U-NII-3, the antenna gain is 4.92 dBi < 6 dBi, so the power density limit shall not be reduced.



### 802.11be (EHT80) 484+242-tone MRU

Chan.	Chan. Freq. (MHz)	PSD w/o Duty Factor (dBm/300kHz)	Duty Factor (dB)	PSD (dBm/500kHz)	PSD Limit (dBm/500kHz)	Test Result
138 (U-NII-3)	5690	-12.59	0.38	-9.99	30	Pass

Note: For U-NII-3, the antenna gain is 4.92 dBi < 6 dBi, so the power density limit shall not be reduced.

#### Spectrum Plot of Maximum Value

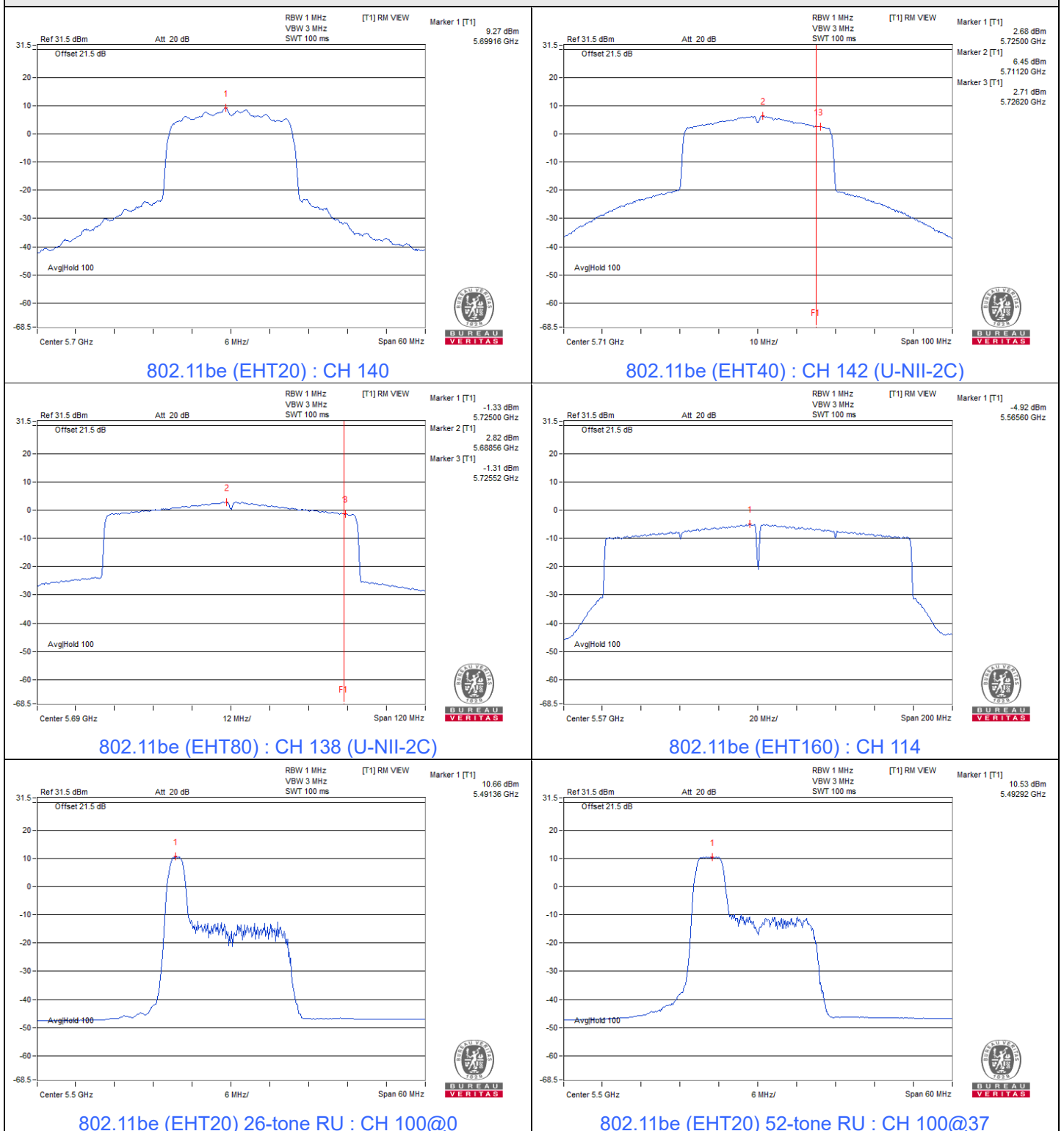



### Spectrum Plot of Maximum Value

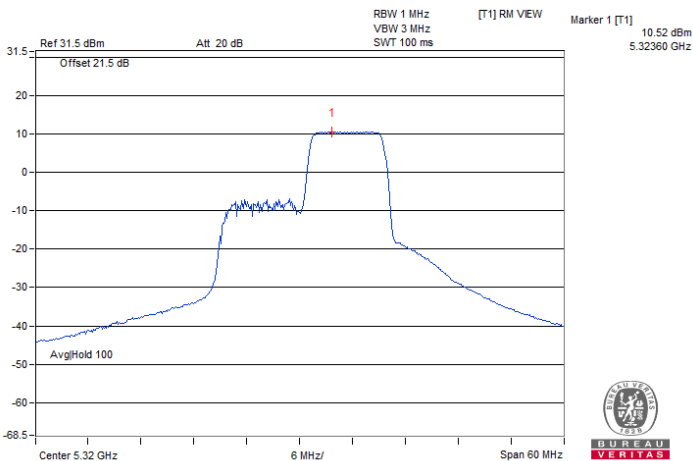

802.11be (EHT20) 106-tone RU : CH 64@54

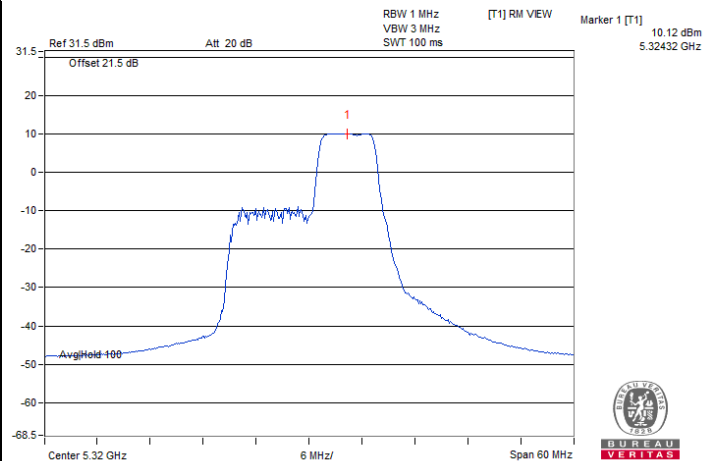

802.11be (EHT20) 52+26-tone MRU : CH 64@72

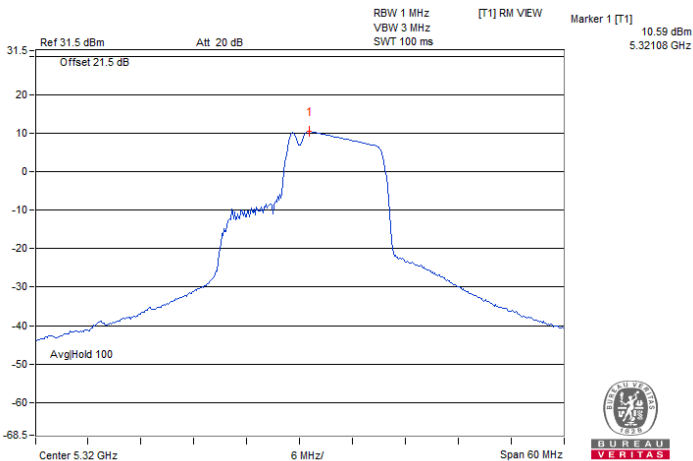

802.11be (EHT20) 106+26-tone MRU : CH 64@83

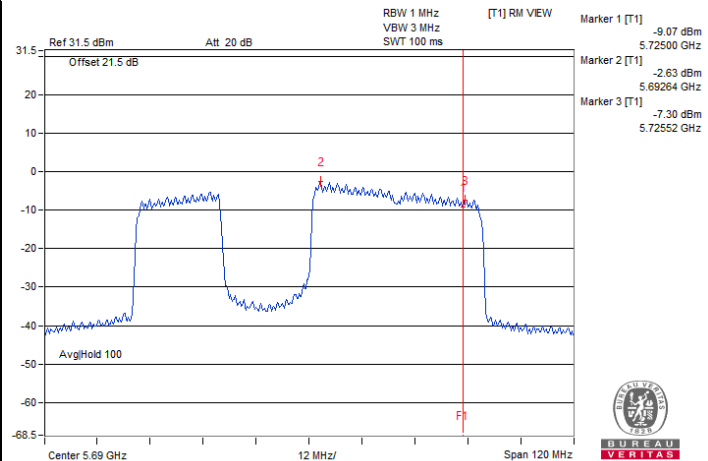

802.11be (EHT80) 484+242-tone MRU : CH 138@91 (U-NII-2C)

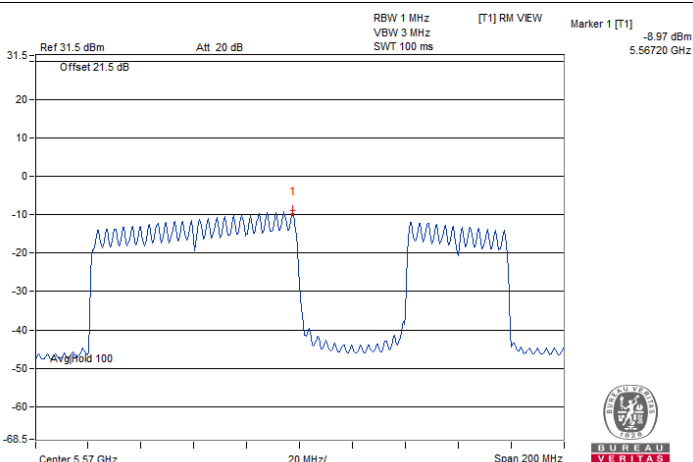

802.11be (EHT160) 996+484-tone MRU : CH 114@94-1

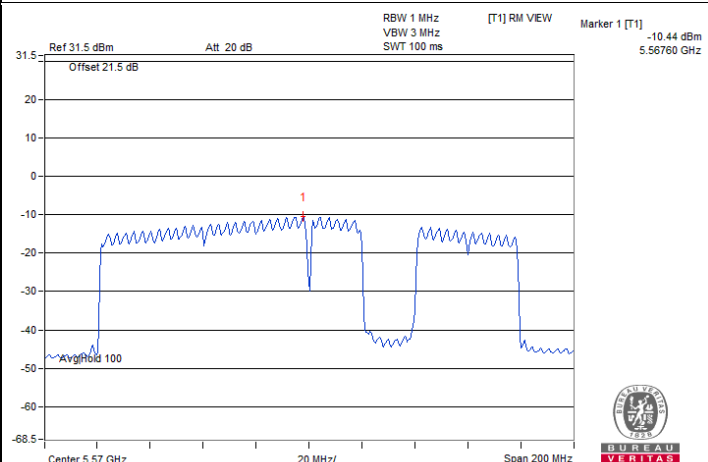

802.11be (EHT160) 996+484+242-tone MRU : CH 114@97-1



### Spectrum Plot of Maximum Value

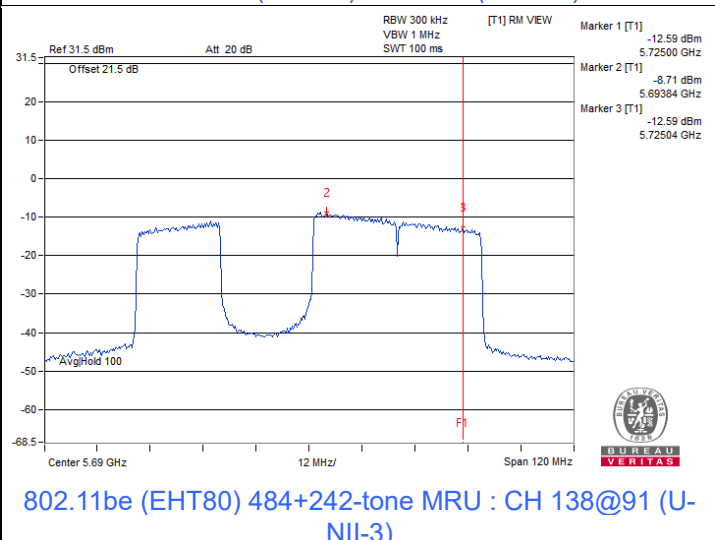
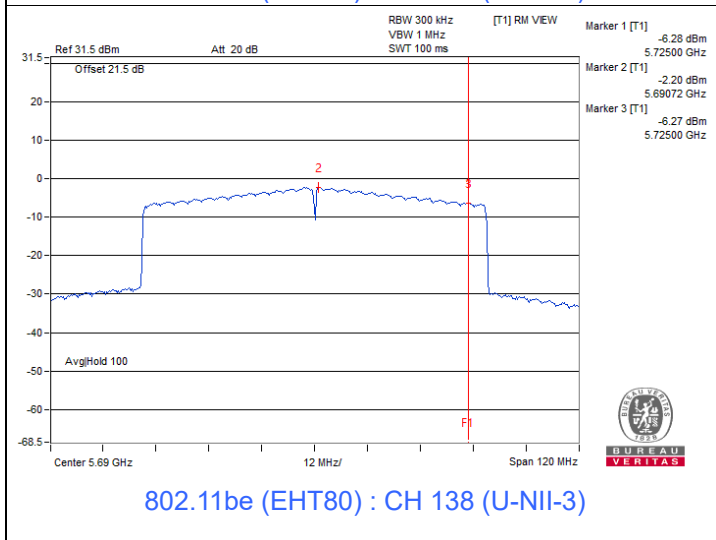
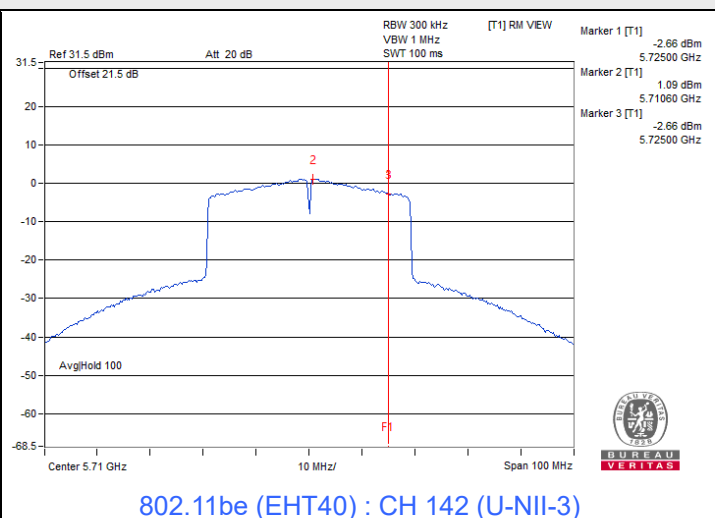
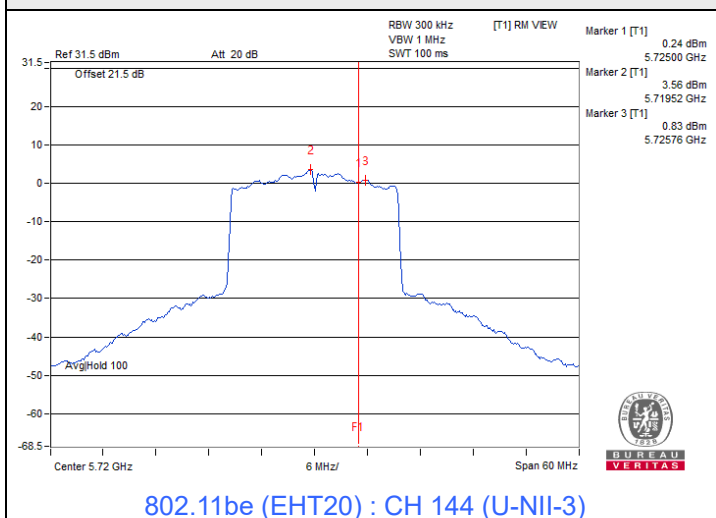



**For 2S2T**

**802.11be (EHT20)**

Chan.	Chan. Freq. (MHz)	PSD w/o Duty Factor (dBm/MHz)		Duty Factor (dB)	Total PSD (dBm/MHz)	Max. PSD Limit (dBm/MHz)	Test Result
		Chain 0	Chain 1				
52	5260	5.53	5.94	2.13	10.88	11	Pass
60	5300	5.06	5.82	2.13	10.60	11	Pass
64	5320	4.94	6.11	2.13	10.70	11	Pass
100	5500	4.77	6.12	2.13	10.64	11	Pass
116	5580	5.00	6.29	2.13	10.83	11	Pass
140	5700	5.37	6.14	2.13	10.91	11	Pass
144 (U-NII-2C)	5720	4.94	6.17	2.13	10.74	11	Pass

**Notes:**

1. Method E) 2) a) of power density measurement of KDB 662911 is using for calculating total power density. Total power density is summing entire spectra across corresponding frequency bins on the various outputs by computer.
2. For U-NII-2A, the directional gain is 4.92 dBi < 6 dBi, so the power density limit shall not be reduced.
3. For U-NII-2C, the directional gain is 4.92 dBi < 6 dBi, so the power density limit shall not be reduced.

**802.11be (EHT40)**

Chan.	Chan. Freq. (MHz)	PSD w/o Duty Factor (dBm/MHz)		Duty Factor (dB)	Total PSD (dBm/MHz)	Max. PSD Limit (dBm/MHz)	Test Result
		Chain 0	Chain 1				
54	5270	3.20	3.27	2.14	8.39	11	Pass
62	5310	0.92	1.27	2.14	6.25	11	Pass
102	5510	0.06	1.20	2.14	5.82	11	Pass
110	5550	3.02	4.13	2.14	8.76	11	Pass
134	5670	1.17	2.64	2.14	7.12	11	Pass
142 (U-NII-2C)	5710	5.04	4.91	2.14	10.13	11	Pass

**Notes:**

1. Method E) 2) a) of power density measurement of KDB 662911 is using for calculating total power density. Total power density is summing entire spectra across corresponding frequency bins on the various outputs by computer.
2. For U-NII-2A, the directional gain is 4.92 dBi < 6 dBi, so the power density limit shall not be reduced.
3. For U-NII-2C, the directional gain is 4.92 dBi < 6 dBi, so the power density limit shall not be reduced.

### 802.11be (EHT80)

Chan.	Chan. Freq. (MHz)	PSD w/o Duty Factor (dBm/MHz)		Duty Factor (dB)	Total PSD (dBm/MHz)	Max. PSD Limit (dBm/MHz)	Test Result
		Chain 0	Chain 1				
58	5290	-4.87	-3.78	2.27	0.99	11	Pass
106	5530	-3.32	-1.79	2.27	2.79	11	Pass
122	5610	-0.60	0.00	2.27	4.99	11	Pass
138 (U-NII-2C)	5690	-0.09	1.06	2.27	5.80	11	Pass

**Notes:**

1. Method E) 2) a) of power density measurement of KDB 662911 is using for calculating total power density. Total power density is summing entire spectra across corresponding frequency bins on the various outputs by computer.
2. For U-NII-2A, the directional gain is 4.92 dBi < 6 dBi, so the power density limit shall not be reduced.
3. For U-NII-2C, the directional gain is 4.92 dBi < 6 dBi, so the power density limit shall not be reduced.

### 802.11be (EHT160)

Chan.	Chan. Freq. (MHz)	PSD w/o Duty Factor (dBm/MHz)		Duty Factor (dB)	Total PSD (dBm/MHz)	Max. PSD Limit (dBm/MHz)	Test Result
		Chain 0	Chain 1				
50 (U-NII-1)	5250	-7.79	-5.43	1.86	-1.58	11	Pass
50 (U-NII-2A)	5250	-7.80	-5.39	1.86	-1.56	11	Pass
114	5570	-6.83	-3.93	1.86	-0.27	11	Pass

**Notes:**

1. Method E) 2) a) of power density measurement of KDB 662911 is using for calculating total power density. Total power density is summing entire spectra across corresponding frequency bins on the various outputs by computer.
2. For U-NII-1, the directional gain is 4.92 dBi < 6dBi, so the power density limit shall not be reduced.
3. For U-NII-2A, the directional gain is 4.92 dBi < 6 dBi, so the power density limit shall not be reduced.
4. For U-NII-2C, the directional gain is 4.92 dBi < 6 dBi, so the power density limit shall not be reduced.

### 802.11be (EHT20) 26-tone RU

Chan.	Chan. Freq. (MHz)	PSD w/o Duty Factor (dBm/MHz)		Duty Factor (dB)	Total PSD (dBm/MHz)	Max. PSD Limit (dBm/MHz)	Test Result
		Chain 0	Chain 1				
64	5320	6.64	7.47	0.52	10.61	11	Pass
100	5500	6.73	7.89	0.52	10.88	11	Pass
140	5700	6.73	7.71	0.52	10.78	11	Pass

**Notes:**

1. Method E) 2) a) of power density measurement of KDB 662911 is using for calculating total power density. Total power density is summing entire spectra across corresponding frequency bins on the various outputs by computer.
2. For U-NII-2A, the directional gain is 4.92 dBi < 6 dBi, so the power density limit shall not be reduced.
3. For U-NII-2C, the directional gain is 4.92 dBi < 6 dBi, so the power density limit shall not be reduced.

### 802.11be (EHT20) 52-tone RU

Chan.	Chan. Freq. (MHz)	PSD w/o Duty Factor (dBm/MHz)		Duty Factor (dB)	Total PSD (dBm/MHz)	Max. PSD Limit (dBm/MHz)	Test Result
		Chain 0	Chain 1				
64	5320	7.20	7.28	0.52	10.77	11	Pass
100	5500	6.27	7.58	0.52	10.50	11	Pass
140	5700	6.43	7.58	0.52	10.57	11	Pass

**Notes:**

1. Method E) 2) a) of power density measurement of KDB 662911 is using for calculating total power density. Total power density is summing entire spectra across corresponding frequency bins on the various outputs by computer.
2. For U-NII-2A, the directional gain is 4.92 dBi < 6 dBi, so the power density limit shall not be reduced.
3. For U-NII-2C, the directional gain is 4.92 dBi < 6 dBi, so the power density limit shall not be reduced.

### 802.11be (EHT20) 106-tone RU

Chan.	Chan. Freq. (MHz)	PSD w/o Duty Factor (dBm/MHz)		Duty Factor (dB)	Total PSD (dBm/MHz)	Max. PSD Limit (dBm/MHz)	Test Result
		Chain 0	Chain 1				
64	5320	6.90	7.50	0.52	10.74	11	Pass
100	5500	6.52	7.61	0.52	10.63	11	Pass
140	5700	6.96	7.73	0.52	10.89	11	Pass

**Notes:**

1. Method E) 2) a) of power density measurement of KDB 662911 is using for calculating total power density. Total power density is summing entire spectra across corresponding frequency bins on the various outputs by computer.
2. For U-NII-2A, the directional gain is 4.92 dBi < 6 dBi, so the power density limit shall not be reduced.
3. For U-NII-2C, the directional gain is 4.92 dBi < 6 dBi, so the power density limit shall not be reduced.

### 802.11be (EHT20) 52+26-tone MRU

Chan.	Chan. Freq. (MHz)	PSD w/o Duty Factor (dBm/MHz)		Duty Factor (dB)	Total PSD (dBm/MHz)	Max. PSD Limit (dBm/MHz)	Test Result
		Chain 0	Chain 1				
64	5320	6.66	7.42	0.52	10.59	11	Pass
100	5500	6.84	7.80	0.52	10.88	11	Pass
140	5700	6.58	7.71	0.52	10.71	11	Pass

**Notes:**

1. Method E) 2) a) of power density measurement of KDB 662911 is using for calculating total power density. Total power density is summing entire spectra across corresponding frequency bins on the various outputs by computer.
2. For U-NII-2A, the directional gain is 4.92 dBi < 6 dBi, so the power density limit shall not be reduced.
3. For U-NII-2C, the directional gain is 4.92 dBi < 6 dBi, so the power density limit shall not be reduced.

### 802.11be (EHT20) 106+26-tone MRU

Chan.	Chan. Freq. (MHz)	PSD w/o Duty Factor (dBm/MHz)		Duty Factor (dB)	Total PSD (dBm/MHz)	Max. PSD Limit (dBm/MHz)	Test Result
		Chain 0	Chain 1				
64	5320	7.18	7.35	0.58	10.86	11	Pass
100	5500	6.85	7.47	0.58	10.76	11	Pass
140	5700	6.93	7.09	0.58	10.60	11	Pass

**Notes:**

- Method E) 2) a) of power density measurement of KDB 662911 is using for calculating total power density. Total power density is summing entire spectra across corresponding frequency bins on the various outputs by computer.
- For U-NII-2A, the directional gain is 4.92 dBi < 6 dBi, so the power density limit shall not be reduced.
- For U-NII-2C, the directional gain is 4.92 dBi < 6 dBi, so the power density limit shall not be reduced.

### 802.11be (EHT80) 484+242-tone MRU

Chan.	Chan. Freq. (MHz)	PSD w/o Duty Factor (dBm/MHz)		Duty Factor (dB)	Total PSD (dBm/MHz)	Max. PSD Limit (dBm/MHz)	Test Result
		Chain 0	Chain 1				
58	5290	-1.41	-0.80	0.67	2.59	11	Pass
106	5530	-0.61	0.38	0.67	3.59	11	Pass
138 (U-NII-2C)	5690	3.52	4.36	0.67	7.64	11	Pass

**Notes:**

- Method E) 2) a) of power density measurement of KDB 662911 is using for calculating total power density. Total power density is summing entire spectra across corresponding frequency bins on the various outputs by computer.
- For U-NII-2A, the directional gain is 4.92 dBi < 6 dBi, so the power density limit shall not be reduced.
- For U-NII-2C, the directional gain is 4.92 dBi < 6 dBi, so the power density limit shall not be reduced.

### 802.11be (EHT160) 996+484-tone MRU

Chan.	Chan. Freq. (MHz)	PSD w/o Duty Factor (dBm/MHz)		Duty Factor (dB)	Total PSD (dBm/MHz)	Max. PSD Limit (dBm/MHz)	Test Result
		Chain 0	Chain 1				
50 (U-NII-1)	5250	-7.09	-6.77	0.68	-3.24	11	Pass
50 (U-NII-2A)	5250	-7.32	-6.56	0.68	-3.23	11	Pass
114	5570	-5.12	-5.67	0.68	-1.70	11	Pass

**Notes:**

- Method E) 2) a) of power density measurement of KDB 662911 is using for calculating total power density. Total power density is summing entire spectra across corresponding frequency bins on the various outputs by computer.
- For U-NII-1, the directional gain is 4.92 dBi < 6dBi, so the power density limit shall not be reduced.
- For U-NII-2A, the directional gain is 4.92 dBi < 6dBi, so the power density limit shall not be reduced.
- For U-NII-2C, the directional gain is 4.92 dBi < 6 dBi, so the power density limit shall not be reduced.

### 802.11be (EHT160) 996+484+242-tone MRU

Chan.	Chan. Freq. (MHz)	PSD w/o Duty Factor (dBm/MHz)		Duty Factor (dB)	Total PSD (dBm/MHz)	Max. PSD Limit (dBm/MHz)	Test Result
		Chain 0	Chain 1				
50 (U-NII-1)	5250	-6.71	-7.34	0.68	-3.32	11	Pass
50 (U-NII-2A)	5250	-6.52	-6.81	0.68	-2.97	11	Pass
114	5570	-5.67	-5.72	0.68	-2.00	11	Pass

**Notes:**

- Method E) 2) a) of power density measurement of KDB 662911 is using for calculating total power density. Total power density is summing entire spectra across corresponding frequency bins on the various outputs by computer.
- For U-NII-1, the directional gain is 4.92 dBi < 6dBi, so the power density limit shall not be reduced.
- For U-NII-2A, the directional gain is 4.92 dBi < 6 dBi, so the power density limit shall not be reduced.
- For U-NII-2C, the directional gain is 4.92 dBi < 6 dBi, so the power density limit shall not be reduced.

### 802.11be (EHT20)

Chan.	Chan. Freq. (MHz)	PSD w/o Duty Factor (dBm/300kHz)		Total PSD w/o Duty Factor (dBm/300kHz)	Duty Factor (dB)	Total PSD (dBm/500kHz)	PSD Limit (dBm/500kHz)	Test Result
		Chain 0	Chain 1					
144 (U-NII-3)	5720	-2.06	-1.26	1.37	2.13	5.72	30	Pass

**Notes:**

- Method E) 2) b) Measure and sum spectral maxima across the outputs of KDB 662911 is using for calculating total power density.
- For U-NII-3, the directional gain is 4.92 dBi < 6 dBi, so the power density limit shall not be reduced.

### 802.11be (EHT40)

Chan.	Chan. Freq. (MHz)	PSD w/o Duty Factor (dBm/300kHz)		Total PSD w/o Duty Factor (dBm/300kHz)	Duty Factor (dB)	Total PSD (dBm/500kHz)	PSD Limit (dBm/500kHz)	Test Result
		Chain 0	Chain 1					
142 (U-NII-3)	5710	-4.13	-3.57	-0.83	2.14	3.53	30	Pass

**Notes:**

- Method E) 2) b) Measure and sum spectral maxima across the outputs of KDB 662911 is using for calculating total power density.
- For U-NII-3, the directional gain is 4.92 dBi < 6 dBi, so the power density limit shall not be reduced.

### 802.11be (EHT80)

Chan.	Chan. Freq. (MHz)	PSD w/o Duty Factor (dBm/300kHz)		Total PSD w/o Duty Factor (dBm/300kHz)	Duty Factor (dB)	Total PSD (dBm/500kHz)	PSD Limit (dBm/500kHz)	Test Result
		Chain 0	Chain 1					
138 (U-NII-3)	5690	-9.54	-8.26	-5.84	2.27	-1.35	30	Pass

**Notes:**

- Method E) 2) b) Measure and sum spectral maxima across the outputs of KDB 662911 is using for calculating total power density.
- For U-NII-3, the directional gain is 4.92 dBi < 6 dBi, so the power density limit shall not be reduced.

**802.11be (EHT80) 484+242-tone MRU**

Chan.	Chan. Freq. (MHz)	PSD w/o Duty Factor (dBm/300kHz)		Total PSD w/o Duty Factor (dBm/300kHz)	Duty Factor (dB)	Total PSD (dBm/500kHz)	PSD Limit (dBm/500kHz)	Test Result
		Chain 0	Chain 1					
138 (U-NII-3)	5690	-6.07	-6.02	-3.03	0.67	-0.14	30	Pass

- Notes:
- Method E) 2) b) Measure and sum spectral maxima across the outputs of KDB 662911 is using for calculating total power density.
  - For U-NII-3, the directional gain is 4.92 dBi < 6 dBi, so the power density limit shall not be reduced.

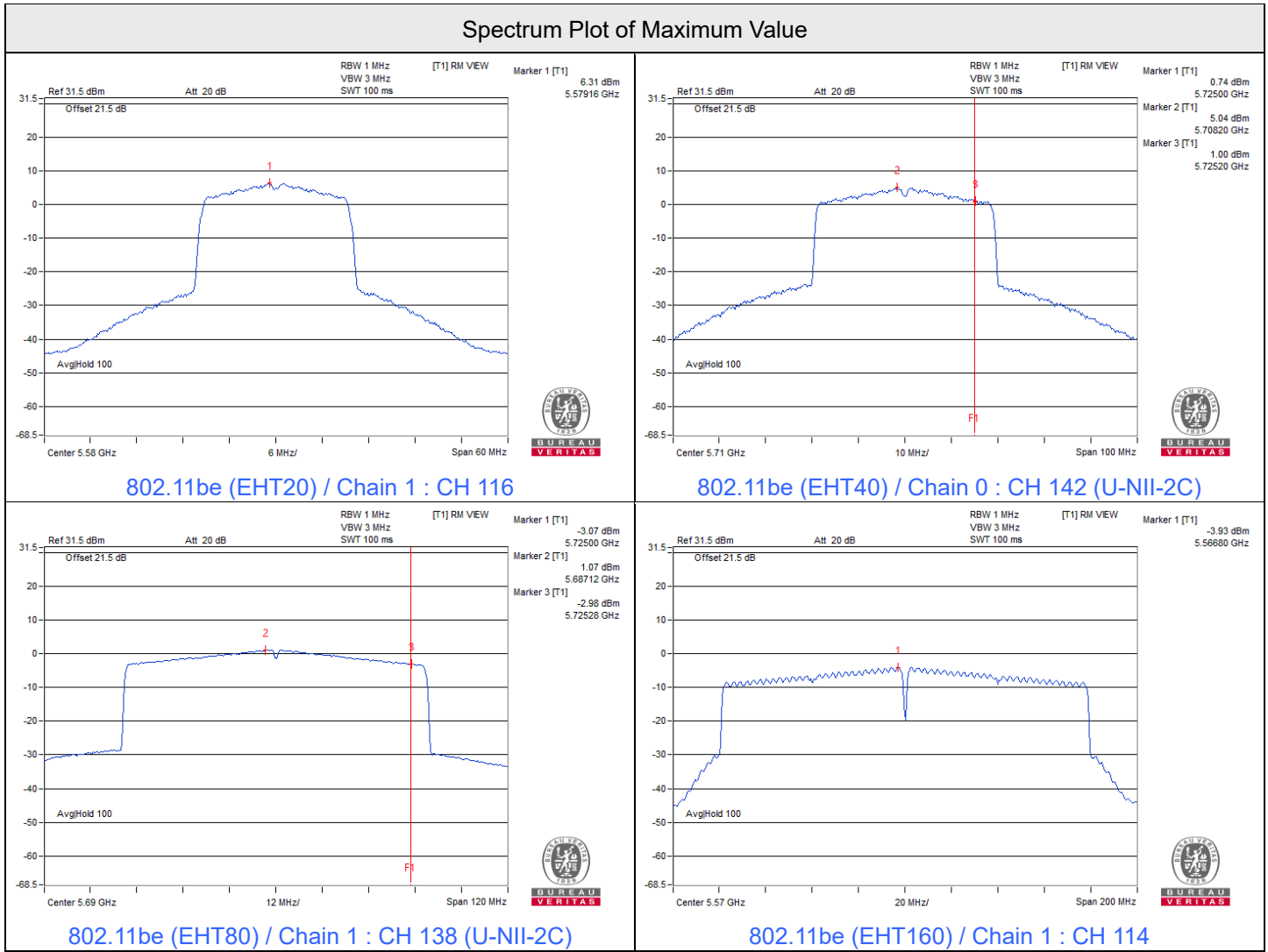



### Spectrum Plot of Maximum Value

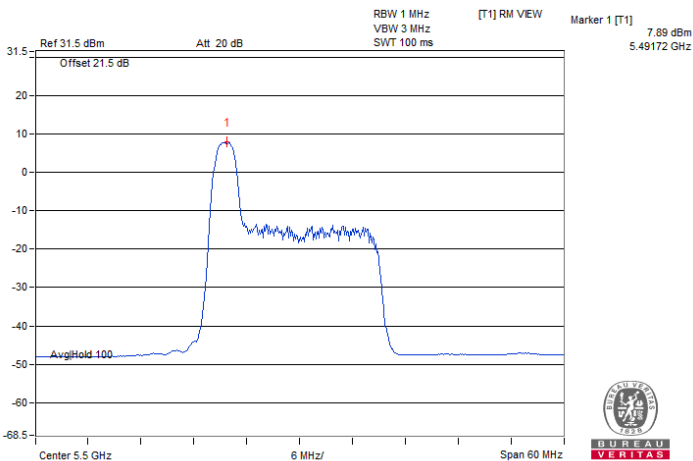

802.11be (EHT20) 26-tone RU / Chain 1 : CH 100@0

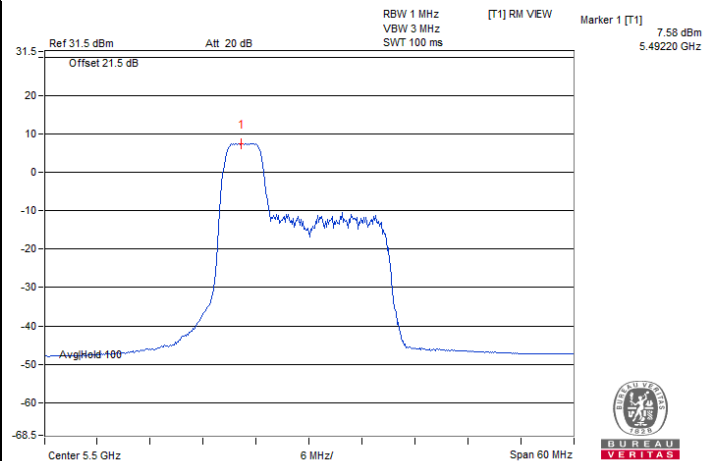

802.11be (EHT20) 52-tone RU / Chain 1 : CH 100@37

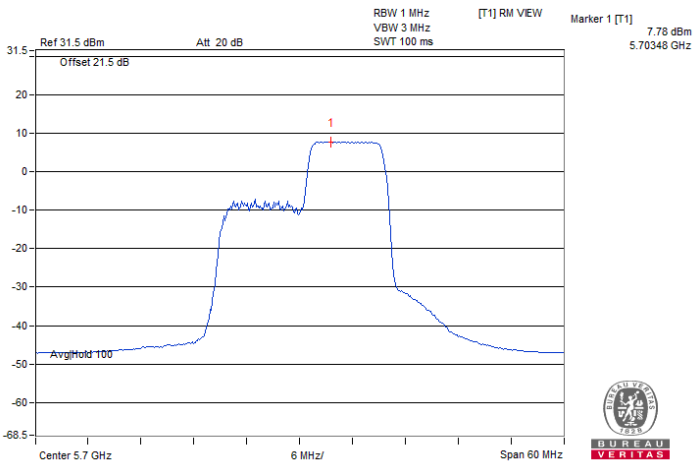

802.11be (EHT20) 106-tone RU / Chain 1 : CH 140@54

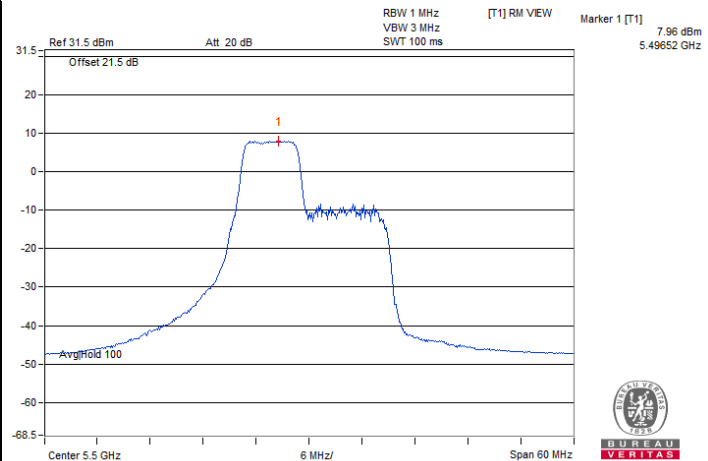

802.11be (EHT20) 52+26-tone MRU / Chain 1 : CH 100@70

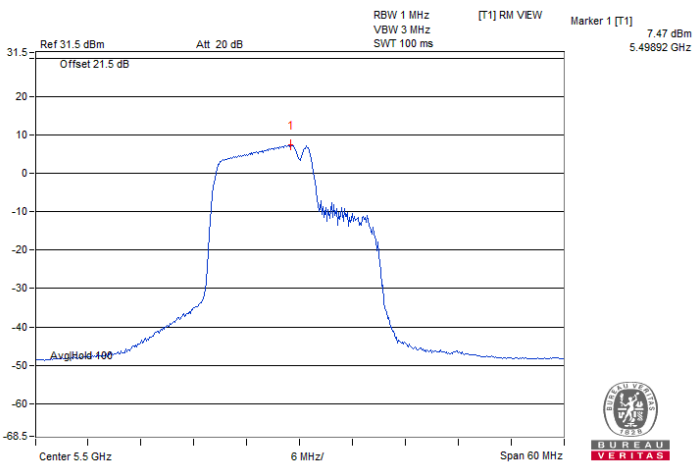

802.11be (EHT20) 106+26-tone MRU / Chain 1 : CH 100@82

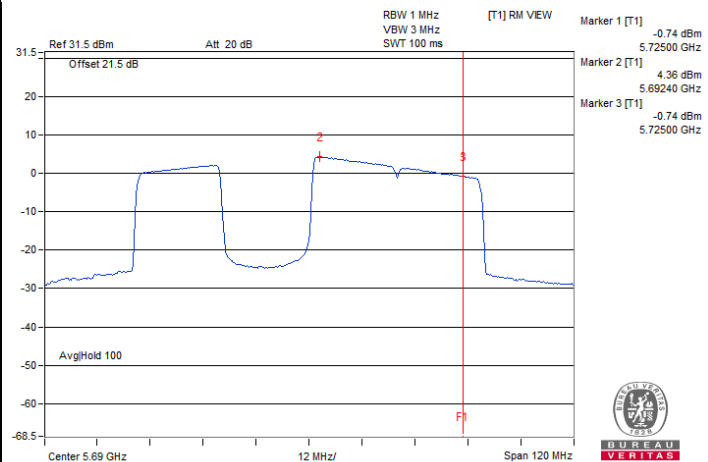

802.11be (EHT80) 484+242-tone MRU / Chain 1 : CH 138@91 (U-NII-2C)

### Spectrum Plot of Maximum Value

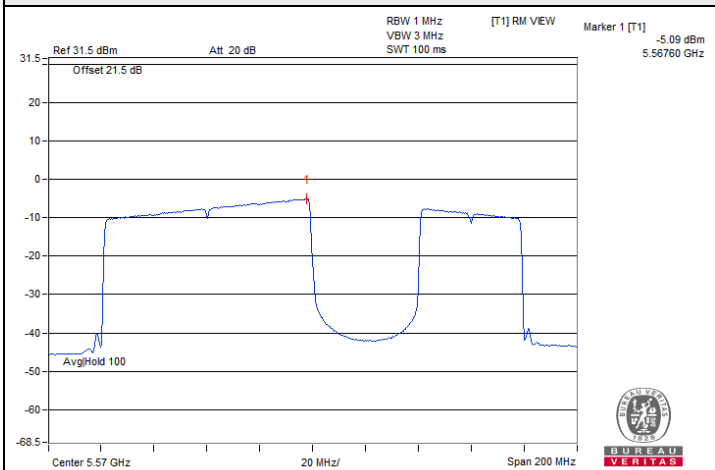

802.11be (EHT160) 996+484-tone MRU / Chain 0 : CH 114@94-1

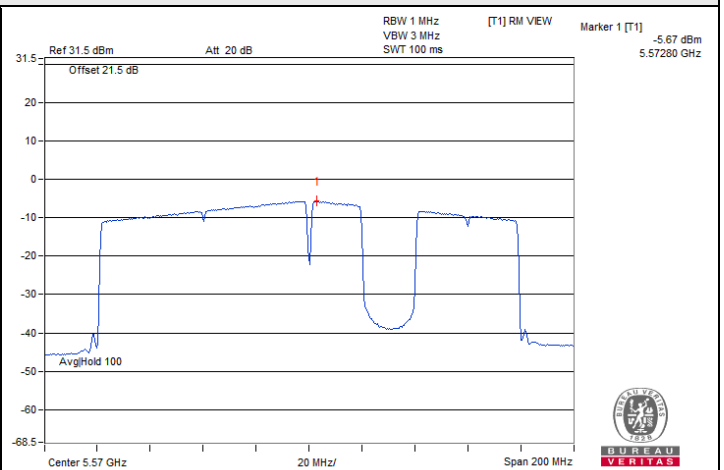

802.11be (EHT160) 996+484+242-tone MRU / Chain 0 : CH 114@97-1

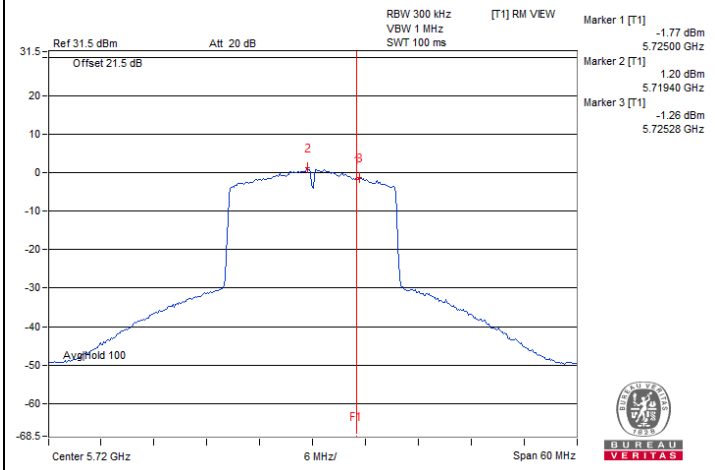

802.11be (EHT20) / Chain 1 : CH 144 (U-NII-3)

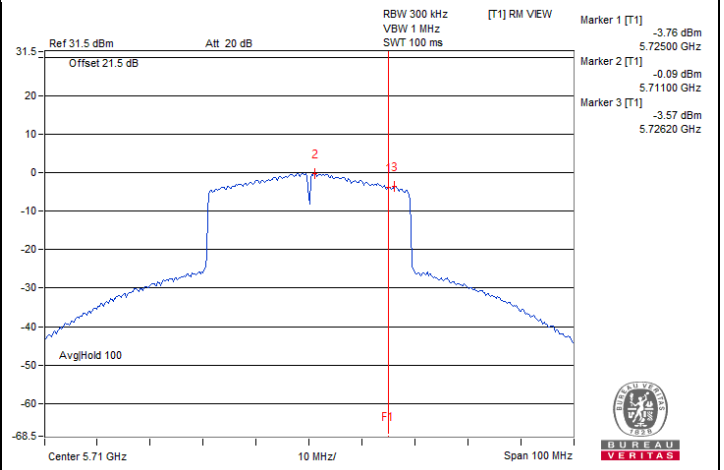

802.11be (EHT40) / Chain 1 : CH 142 (U-NII-3)

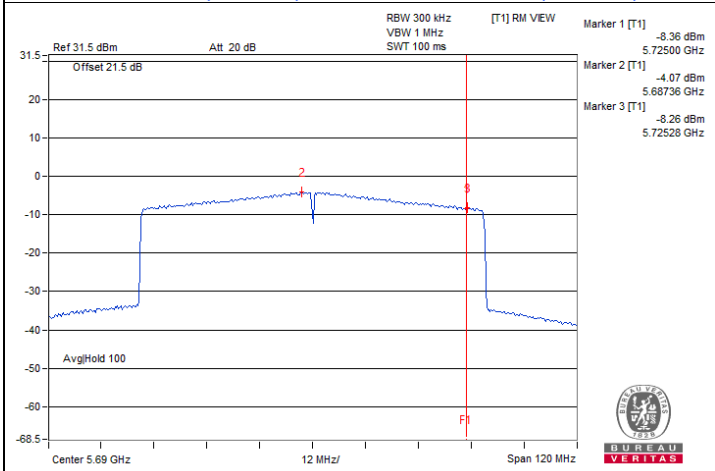

802.11be (EHT80) / Chain 1 : CH 138 (U-NII-3)

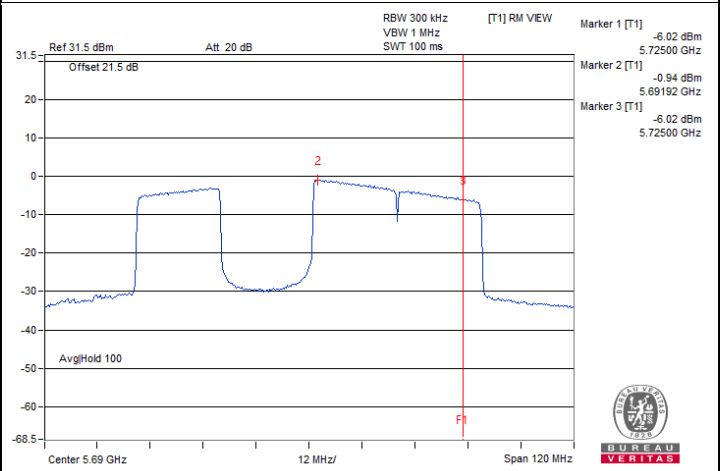

802.11be (EHT80) 484+242-tone MRU / Chain 1 : CH 138@91 (U-NII-3)



#### 7.4 6 dB Bandwidth

Input Power:	3.3 Vdc	Environmental Conditions:	25°C, 60% RH	Tested By:	Willy Lin
--------------	---------	---------------------------	--------------	------------	-----------

#### For 1S1T

##### 802.11be (EHT20)

Channel	Frequency (MHz)	6 dB Bandwidth (MHz)	Minimum Limit (MHz)	Test Result
144 (U-NII-3)	5720	4.01	0.5	Pass

##### 802.11be (EHT40)

Channel	Frequency (MHz)	6 dB Bandwidth (MHz)	Minimum Limit (MHz)	Test Result
142 (U-NII-3)	5710	1.4	0.5	Pass

##### 802.11be (EHT80)

Channel	Frequency (MHz)	6 dB Bandwidth (MHz)	Minimum Limit (MHz)	Test Result
138 (U-NII-3)	5690	2.51	0.5	Pass

### Spectrum Plot of Minimum Value

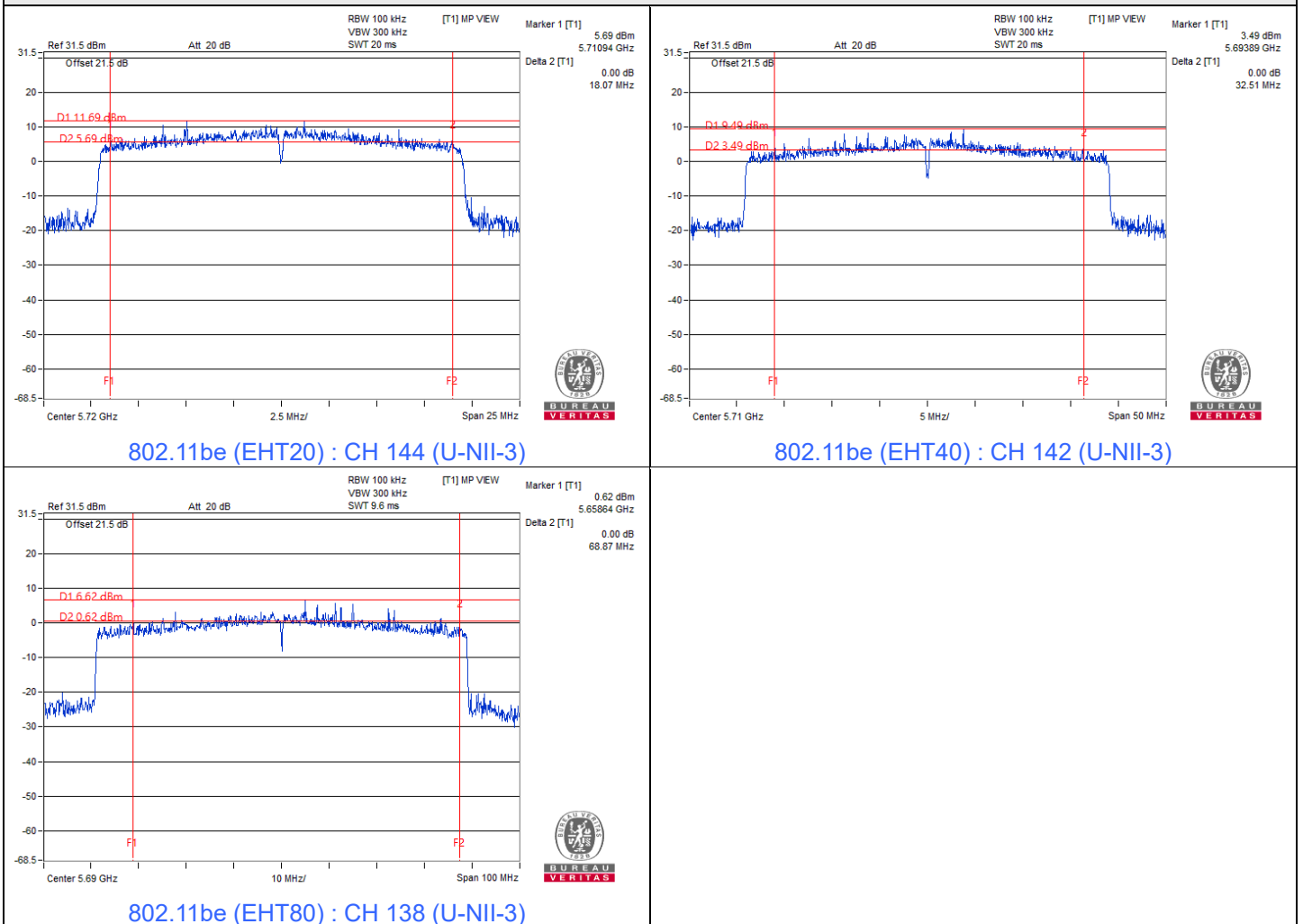

Note: For U-NII-3 straddle channel = Marker 1 + Delta 2 - 5725 MHz

**For 2S2T**

**802.11be (EHT20)**

Channel	Frequency (MHz)	6 dB Bandwidth (MHz)		Minimum Limit (MHz)	Test Result
		Chain 0	Chain 1		
144 (U-NII-3)	5720	1.93	2.41	0.5	Pass

**802.11be (EHT40)**

Channel	Frequency (MHz)	6 dB Bandwidth (MHz)		Minimum Limit (MHz)	Test Result
		Chain 0	Chain 1		
142 (U-NII-3)	5710	3.35	2.48	0.5	Pass

**802.11be (EHT80)**

Channel	Frequency (MHz)	6 dB Bandwidth (MHz)		Minimum Limit (MHz)	Test Result
		Chain 0	Chain 1		
138 (U-NII-3)	5690	2.44	2.51	0.5	Pass

### Spectrum Plot of Minimum Value

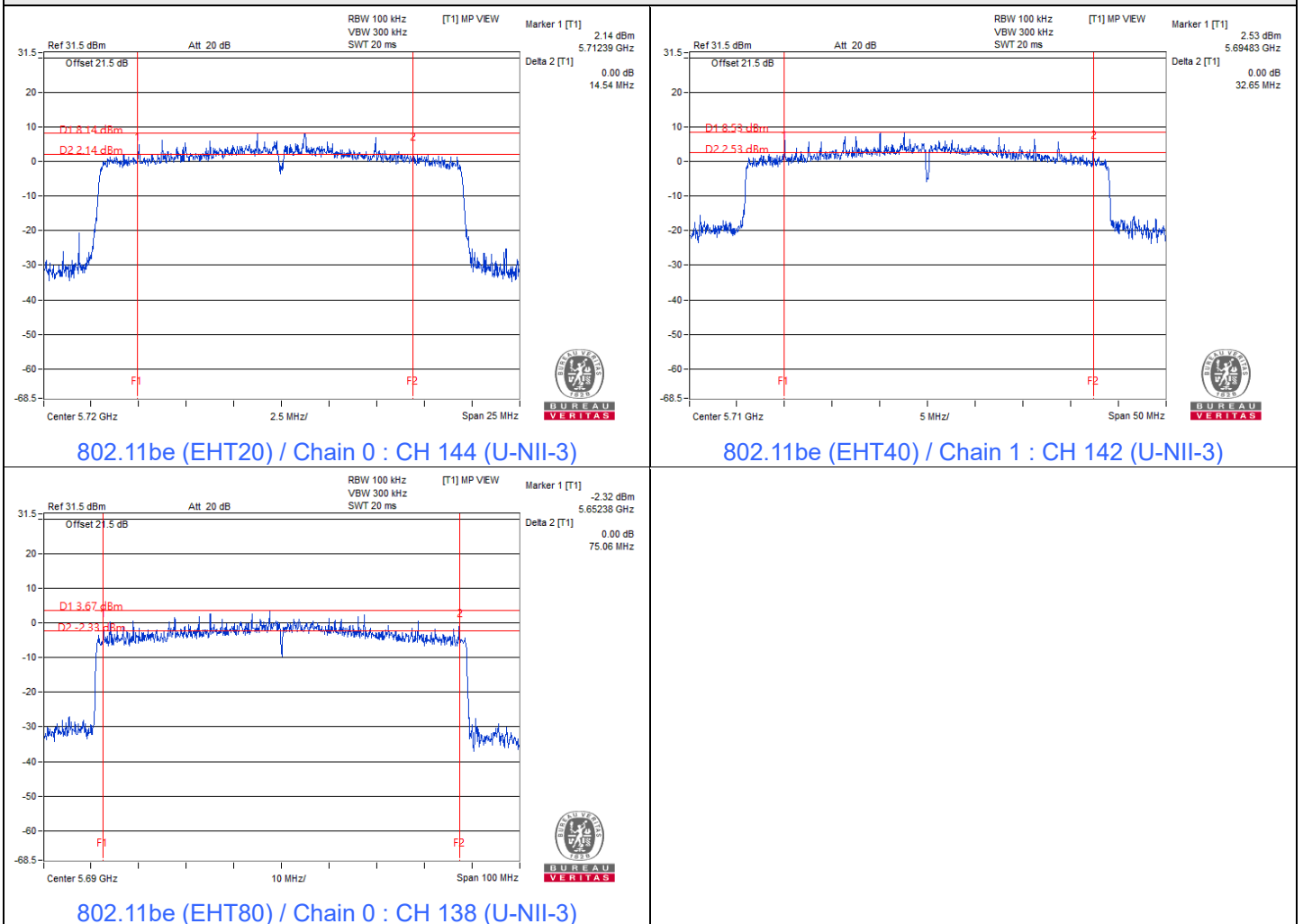

Note: For U-NII-3 straddle channel = Marker 1 + Delta 2 - 5725 MHz

## 7.5 Occupied Bandwidth

Input Power:	3.3 Vdc	Environmental Conditions:	25°C, 60% RH	Tested By:	Willy Lin
--------------	---------	---------------------------	--------------	------------	-----------

### For 1S1T

#### 802.11be (EHT20)

Channel	Frequency (MHz)	Occupied Bandwidth (MHz)
52	5260	18.84
60	5300	18.9
64	5320	18.78
100	5500	18.78
116	5580	18.84
140	5700	18.84
144 (U-NII-2C)	5720	14.42
144 (U-NII-3)	5720	4.42

#### 802.11be (EHT40)

Channel	Frequency (MHz)	Occupied Bandwidth (MHz)
54	5270	37.8
62	5310	37.68
102	5510	37.8
110	5550	37.68
134	5670	37.8
142 (U-NII-2C)	5710	33.84
142 (U-NII-3)	5710	3.84

#### 802.11be (EHT80)

Channel	Frequency (MHz)	Occupied Bandwidth (MHz)
58	5290	76.8
106	5530	77.04
122	5610	77.04
138 (U-NII-2C)	5690	73.4
138 (U-NII-3)	5690	3.4

### 802.11be (EHT160)

Channel	Frequency (MHz)	Occupied Bandwidth (MHz)
50 (U-NII-1)	5250	78.24
50 (U-NII-2A)	5250	77.76
114	5570	156

### 802.11be (EHT20) 26-tone RU

Channel	Frequency (MHz)	Occupied Bandwidth (MHz)
64	5320	18.12
100	5500	18.18
140	5700	18.24

### 802.11be (EHT20) 52-tone RU

Channel	Frequency (MHz)	Occupied Bandwidth (MHz)
64	5320	18.12
100	5500	18.12
140	5700	18.18

### 802.11be (EHT20) 106-tone RU

Channel	Frequency (MHz)	Occupied Bandwidth (MHz)
64	5320	18.18
100	5500	18.12
140	5700	18.12

### 802.11be (EHT20) 52+26-tone MRU

Channel	Frequency (MHz)	Occupied Bandwidth (MHz)
64	5320	17.16
100	5500	17.16
140	5700	17.16

**802.11be (EHT20) 106+26-tone MRU**

Channel	Frequency (MHz)	Occupied Bandwidth (MHz)
64	5320	17.88
100	5500	17.76
140	5700	17.34

**802.11be (EHT80) 484+242-tone MRU**

Channel	Frequency (MHz)	Occupied Bandwidth (MHz)
58	5290	77.28
106	5530	77.28
138 (U-NII-2C)	5690	73.64
138 (U-NII-3)	5690	3.64

**802.11be (EHT160) 996+484-tone MRU**

Channel	Frequency (MHz)	Occupied Bandwidth (MHz)
50 (U-NII-1)	5250	78.24
50 (U-NII-2A)	5250	38.88
114	5570	156

**802.11be (EHT160) 996+484+242-tone MRU**

Channel	Frequency (MHz)	Occupied Bandwidth (MHz)
50 (U-NII-1)	5250	77.76
50 (U-NII-2A)	5250	59.04
114	5570	156



### Spectrum Plot of Maximum Value

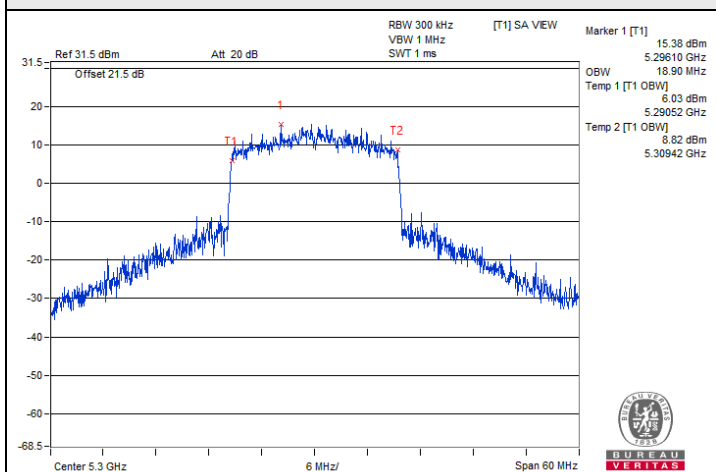

802.11be (EHT20) : CH 60

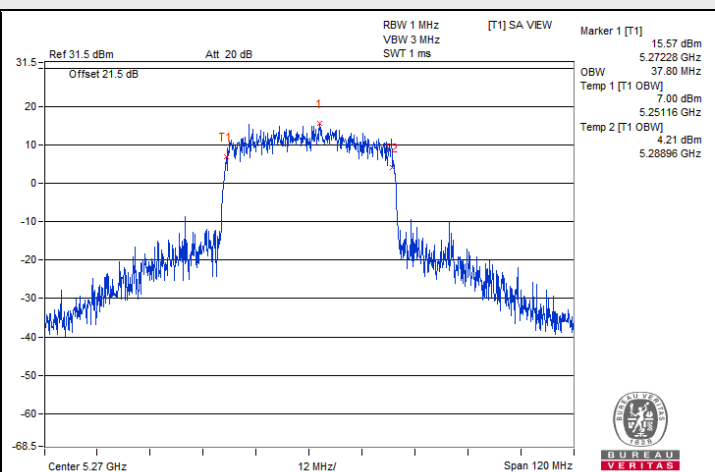

802.11be (EHT40) : CH 54

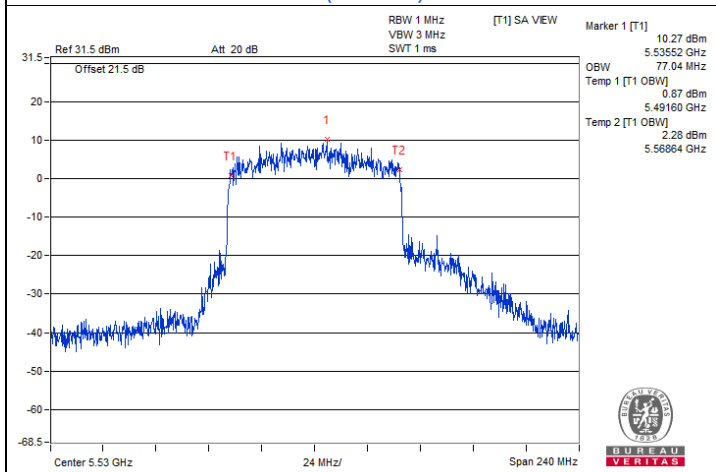

802.11be (EHT80) : CH 106

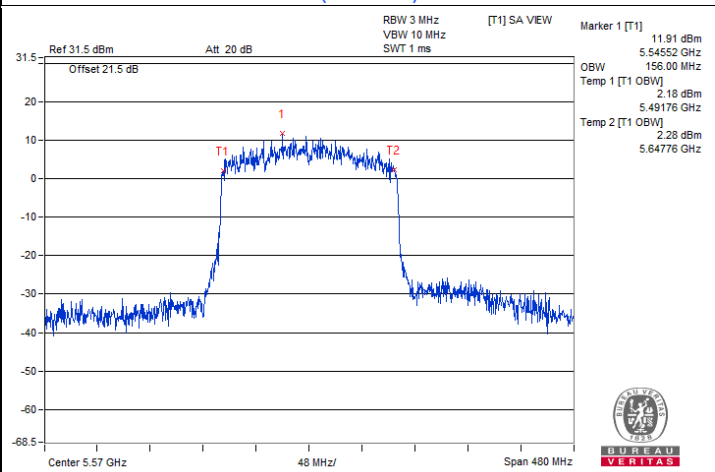

802.11be (EHT160) : CH 114

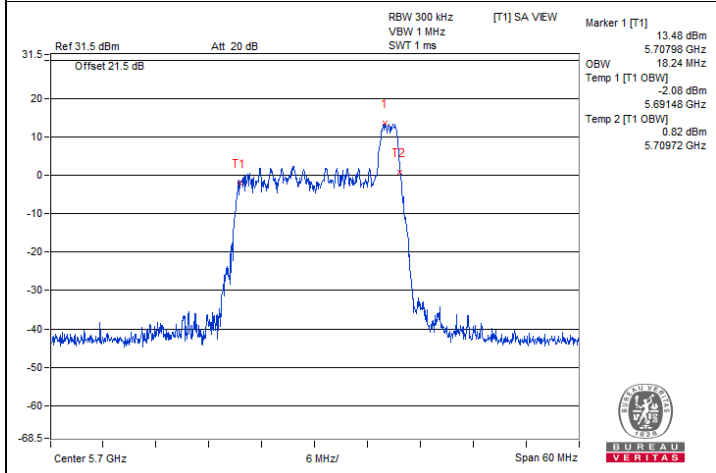

802.11be (EHT20) 26-tone RU : CH 140@8

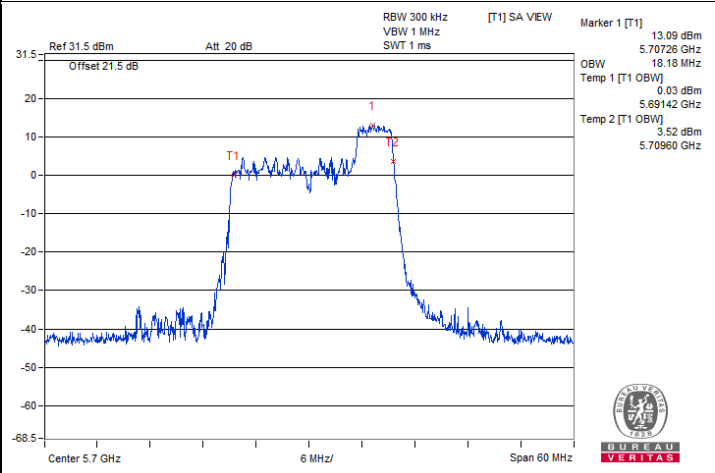

802.11be (EHT20) 52-tone RU : CH 140@40





### Spectrum Plot of Maximum Value

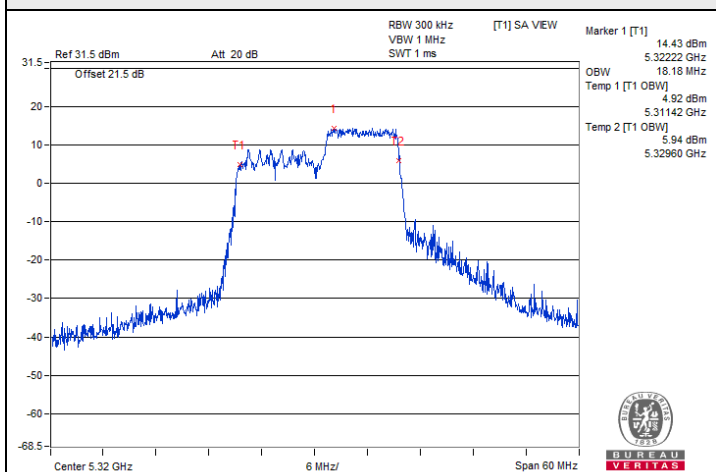

802.11be (EHT20) 106-tone RU : CH 64@54

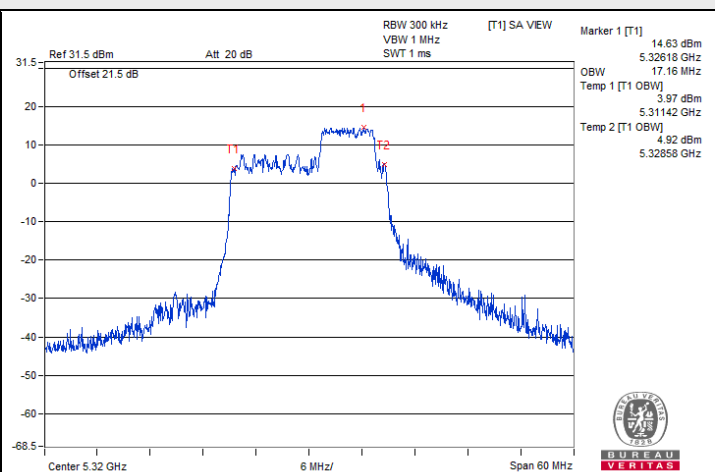

802.11be (EHT20) 52+26-tone MRU : CH 64@72

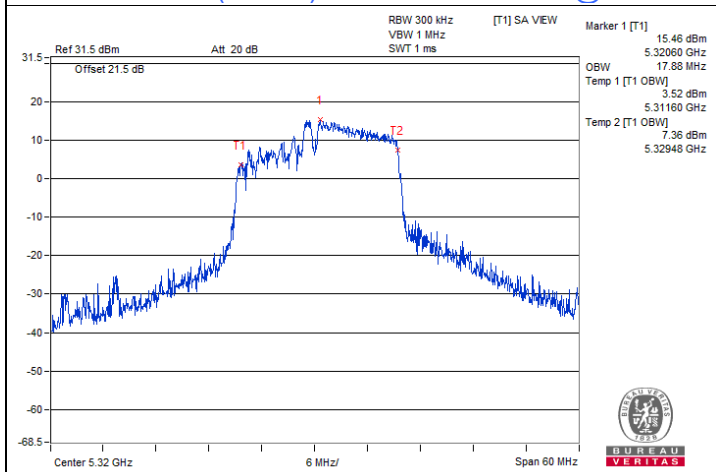

802.11be (EHT20) 106+26-tone MRU : CH 64@83

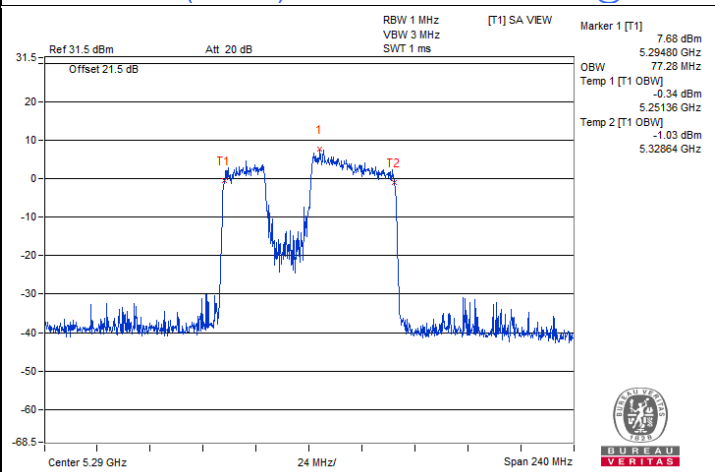

802.11be (EHT80) 484+242-tone MRU : CH 58@91

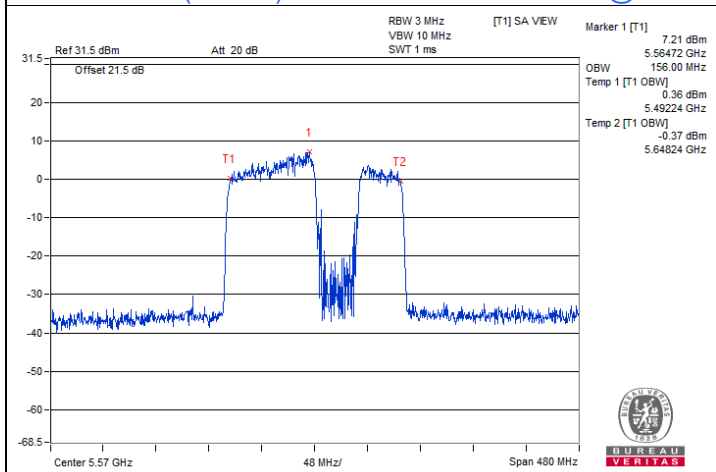

802.11be (EHT160) 996+484-tone MRU : CH 114@94-1

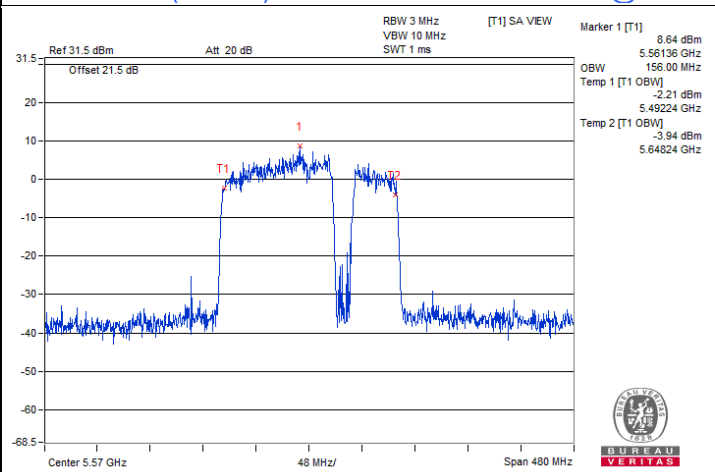

802.11be (EHT160) 996+484+242-tone MRU : CH 114@97-1

**For 2S2T**
**802.11be (EHT20)**

Channel	Frequency (MHz)	Occupied Bandwidth (MHz)	
		Chain 0	Chain 1
52	5260	18.78	18.78
60	5300	18.78	18.78
64	5320	18.78	18.84
100	5500	18.78	18.84
116	5580	18.78	18.78
140	5700	18.78	18.78
144 (U-NII-2C)	5720	14.42	14.42
144 (U-NII-3)	5720	4.36	4.36

**802.11be (EHT40)**

Channel	Frequency (MHz)	Occupied Bandwidth (MHz)	
		Chain 0	Chain 1
54	5270	37.68	37.56
62	5310	37.56	37.80
102	5510	37.80	37.68
110	5550	37.80	37.80
134	5670	37.68	37.80
142 (U-NII-2C)	5710	33.84	33.96
142 (U-NII-3)	5710	3.96	3.84

**802.11be (EHT80)**

Channel	Frequency (MHz)	Occupied Bandwidth (MHz)	
		Chain 0	Chain 1
58	5290	77.28	77.28
106	5530	77.04	77.28
122	5610	77.04	77.28
138 (U-NII-2C)	5690	73.64	73.64
138 (U-NII-3)	5690	3.40	3.40

**802.11be (EHT160)**

Channel	Frequency (MHz)	Occupied Bandwidth (MHz)	
		Chain 0	Chain 1
50 (U-NII-1)	5250	78.24	78.24
50 (U-NII-2A)	5250	77.28	77.28
114	5570	155.52	155.04

**802.11be (EHT20) 26-tone RU**

Channel	Frequency (MHz)	Occupied Bandwidth (MHz)	
		Chain 0	Chain 1
64	5320	18.18	18.24
100	5500	18.18	18.24
140	5700	18.24	18.30

**802.11be (EHT20) 52-tone RU**

Channel	Frequency (MHz)	Occupied Bandwidth (MHz)	
		Chain 0	Chain 1
64	5320	18.12	18.00
100	5500	18.06	18.18
140	5700	18.24	18.12

**802.11be (EHT20) 106-tone RU**

Channel	Frequency (MHz)	Occupied Bandwidth (MHz)	
		Chain 0	Chain 1
64	5320	18.18	18.12
100	5500	18.18	18.18
140	5700	17.76	18.18

**802.11be (EHT20) 52+26-tone MRU**

Channel	Frequency (MHz)	Occupied Bandwidth (MHz)	
		Chain 0	Chain 1
64	5320	17.16	17.16
100	5500	17.16	17.16
140	5700	17.22	16.92

**802.11be (EHT20) 106+26-tone MRU**

Channel	Frequency (MHz)	Occupied Bandwidth (MHz)	
		Chain 0	Chain 1
64	5320	17.58	17.76
100	5500	17.82	17.94
140	5700	17.64	17.88

**802.11be (EHT80) 484+242-tone MRU**

Channel	Frequency (MHz)	Occupied Bandwidth (MHz)	
		Chain 0	Chain 1
58	5290	77.28	77.28
106	5530	77.04	77.28
138 (U-NII-2C)	5690	73.64	73.64
138 (U-NII-3)	5690	3.88	3.64

**802.11be (EHT160) 996+484-tone MRU**

Channel	Frequency (MHz)	Occupied Bandwidth (MHz)	
		Chain 0	Chain 1
50 (U-NII-1)	5250	78.72	78.24
50 (U-NII-2A)	5250	39.36	38.88
114	5570	156.48	156.48

**802.11be (EHT160) 996+484+242-tone MRU**

Channel	Frequency (MHz)	Occupied Bandwidth (MHz)	
		Chain 0	Chain 1
50 (U-NII-1)	5250	78.24	78.24
50 (U-NII-2A)	5250	60.48	59.52
114	5570	155.52	156.48



### Spectrum Plot of Maximum Value

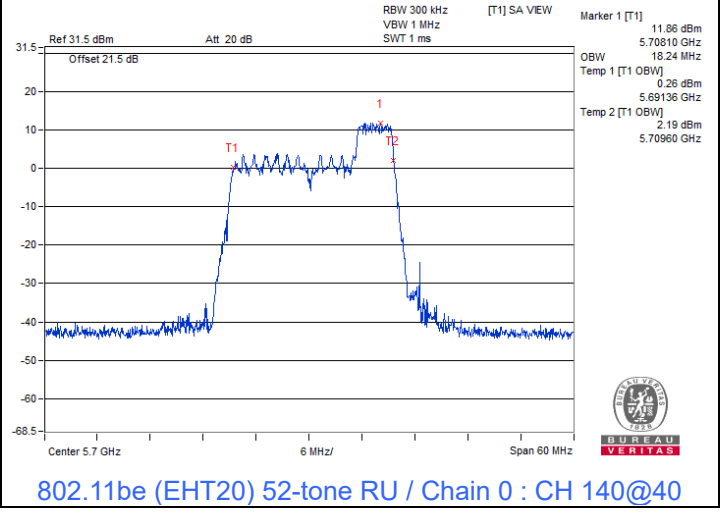
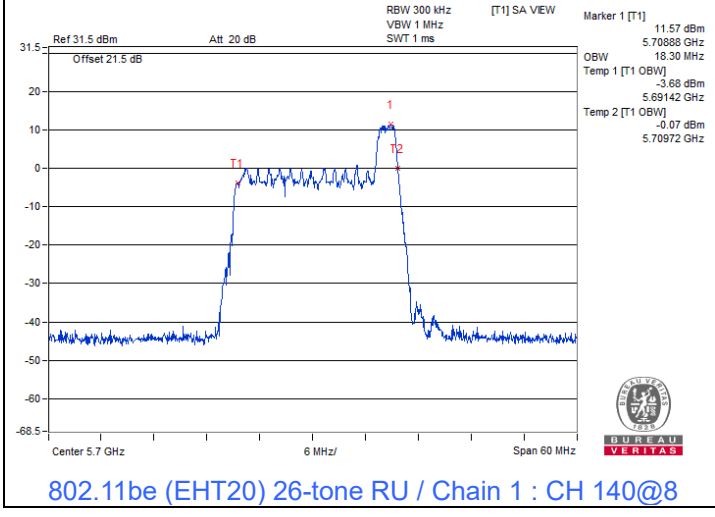
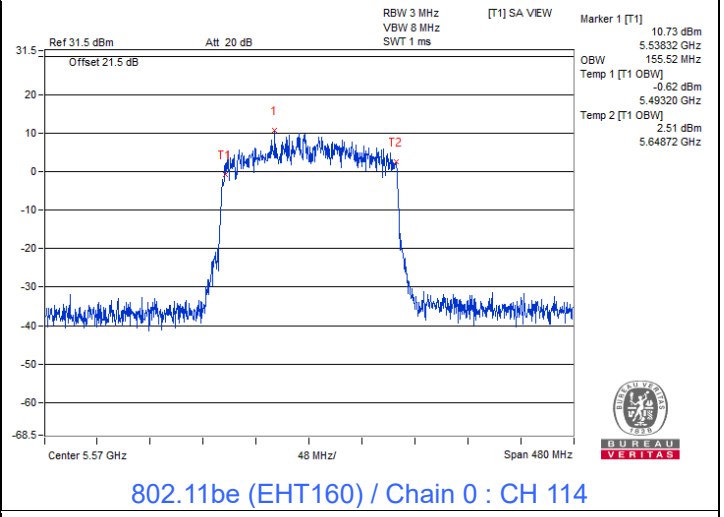
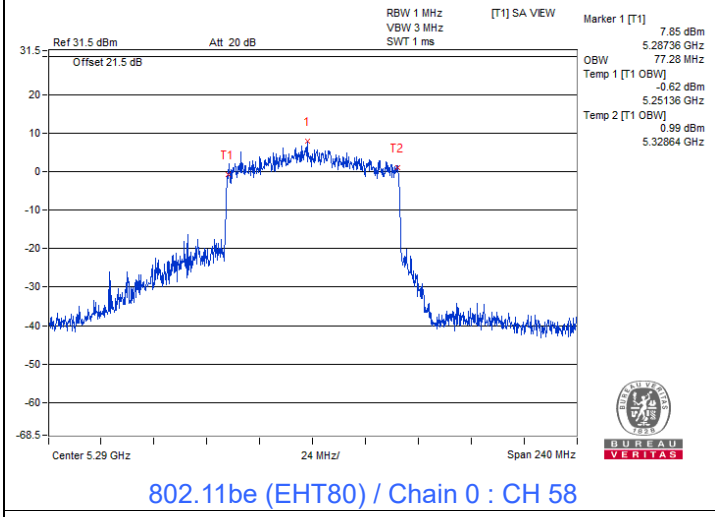
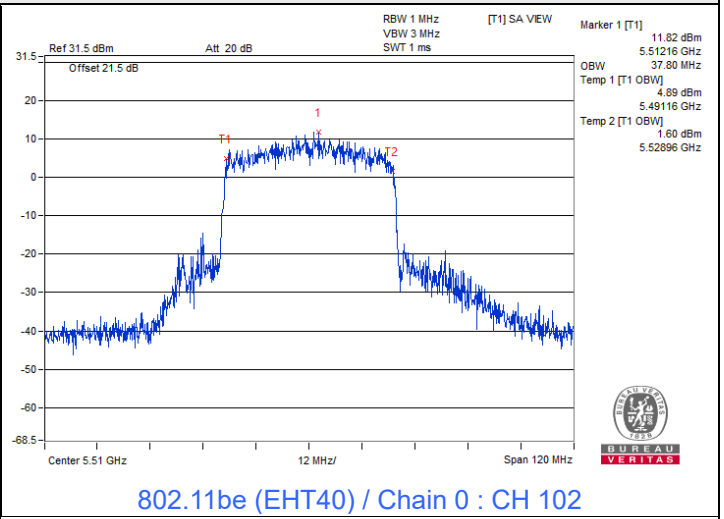
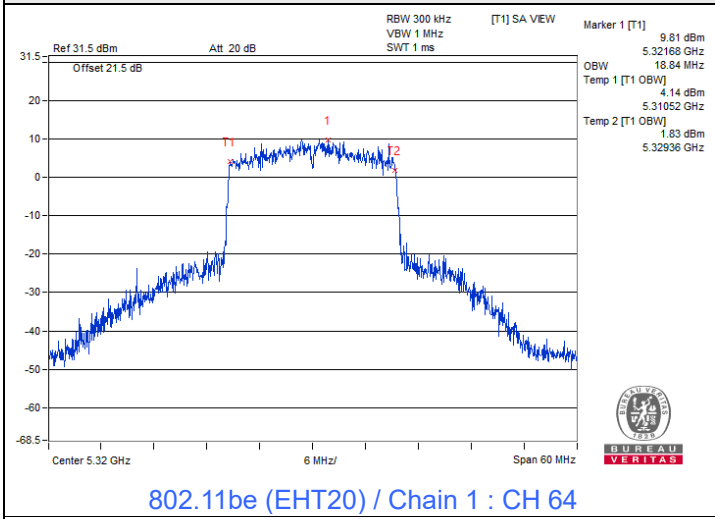



### Spectrum Plot of Maximum Value

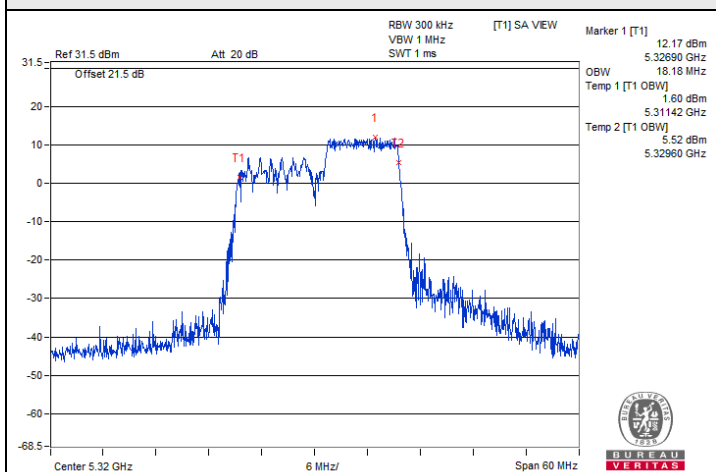

802.11be (EHT20) 106-tone RU / Chain 0 : CH 64@54

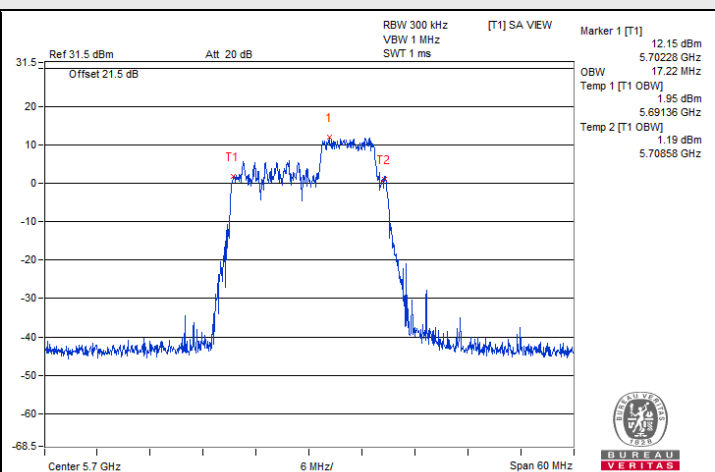

802.11be (EHT20) 52+26-tone MRU / Chain 0 : CH 140@72

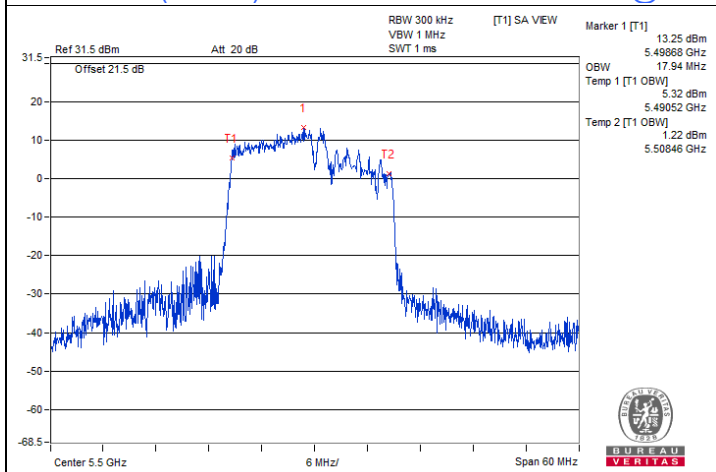

802.11be (EHT20) 106+26-tone MRU / Chain 1 : CH 100@82

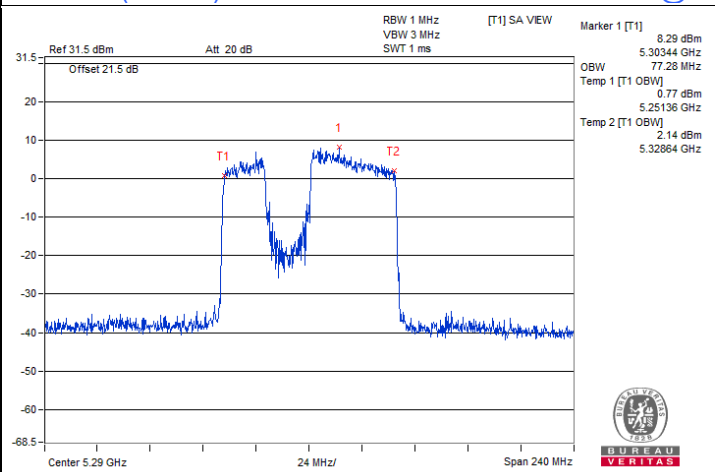

802.11be (EHT80) 484+242-tone MRU / Chain 0 : CH 58@91

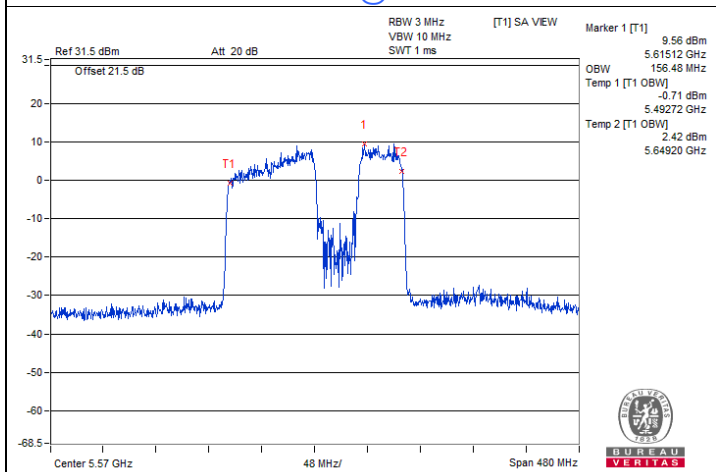

802.11be (EHT160) 996+484-tone MRU / Chain 0 : CH 114@94-1

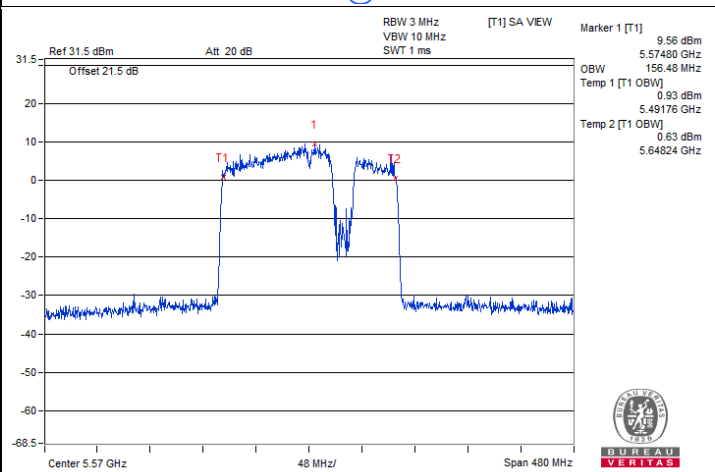

802.11be (EHT160) 996+484+242-tone MRU / Chain 1 : CH 114@97-1

## 7.6 Frequency Stability

Input Power:	3.3 Vdc	Environmental Conditions:	25°C, 60% RH	Tested By:	Willy Lin
--------------	---------	---------------------------	--------------	------------	-----------

Frequency Stability Versus Temperature									
Operating Frequency: 5500 MHz									
Temp. (°C)	Power Supply (Vdc)	0 Minute		2 Minutes		5 Minutes		10 Minutes	
		Measured Frequency (MHz)	Test Result	Measured Frequency (MHz)	Test Result	Measured Frequency (MHz)	Test Result	Measured Frequency (MHz)	Test Result
70	3.3	5500.0176	Pass	5500.0164	Pass	5500.0185	Pass	5500.0175	Pass
60	3.3	5500.0031	Pass	5500.0042	Pass	5500.0024	Pass	5500.0024	Pass
50	3.3	5499.9931	Pass	5499.9959	Pass	5499.9928	Pass	5499.9941	Pass
40	3.3	5500.0051	Pass	5500.0069	Pass	5500.0054	Pass	5500.0059	Pass
30	3.3	5500.0229	Pass	5500.0227	Pass	5500.022	Pass	5500.024	Pass
20	3.3	5500.0151	Pass	5500.0174	Pass	5500.0145	Pass	5500.0151	Pass
10	3.3	5500.0203	Pass	5500.0206	Pass	5500.0222	Pass	5500.0244	Pass
0	3.3	5500.0207	Pass	5500.0217	Pass	5500.0212	Pass	5500.0243	Pass
-10	3.3	5499.975	Pass	5499.9772	Pass	5499.9737	Pass	5499.9731	Pass

Frequency Stability Versus Voltage									
Operating Frequency: 5500 MHz									
Temp. (°C)	Power Supply (Vdc)	0 Minute		2 Minutes		5 Minutes		10 Minutes	
		Measured Frequency (MHz)	Test Result	Measured Frequency (MHz)	Test Result	Measured Frequency (MHz)	Test Result	Measured Frequency (MHz)	Test Result
20	3.795	5500.0228	Pass	5500.0238	Pass	5500.0238	Pass	5500.0237	Pass
	3.3	5500.0151	Pass	5500.0174	Pass	5500.0145	Pass	5500.0151	Pass
	2.805	5500.0195	Pass	5500.0188	Pass	5500.0195	Pass	5500.0172	Pass

## 7.7 AC Power Conducted Emissions

### For 1S1T

<b>RF Mode</b>	802.11be (EHT40)	<b>Channel</b>	CH 110 : 5550 MHz
<b>Frequency Range</b>	150 kHz ~ 30 MHz	<b>Detector Function &amp; Resolution Bandwidth</b>	Quasi-Peak (QP) / Average (AV), 9 kHz
<b>Input Power (System)</b>	120 Vac, 60 Hz	<b>Environmental Conditions</b>	24°C, 66% RH
<b>Tested By</b>	Sampson Chen		

Phase Of Power : Line (L)										
No	Frequency (MHz)	Correction Factor (dB)	Reading Value (dBuV)		Emission Level (dBuV)		Limit (dBuV)		Margin (dB)	
			Q.P.	AV.	Q.P.	AV.	Q.P.	AV.	Q.P.	AV.
1	0.15651	9.93	43.23	21.34	53.16	31.27	65.65	55.65	-12.49	-24.38
2	0.19359	9.93	40.10	23.70	50.03	33.63	63.88	53.88	-13.85	-20.25
3	0.49213	9.95	15.35	0.41	25.30	10.36	56.13	46.13	-30.83	-35.77
4	3.56501	10.10	25.20	17.10	35.30	27.20	56.00	46.00	-20.70	-18.80
5	15.98256	10.88	18.34	10.51	29.22	21.39	60.00	50.00	-30.78	-28.61
6	23.86237	11.29	22.41	16.51	33.70	27.80	60.00	50.00	-26.30	-22.20

#### Remarks:

1. Q.P. and AV. are abbreviations of quasi-peak and average individually.
2. The emission levels of other frequencies were very low against the limit.
3. Margin value = Emission level – Limit value
4. Correction factor = Insertion loss + Cable loss
5. Emission Level = Correction Factor + Reading Value

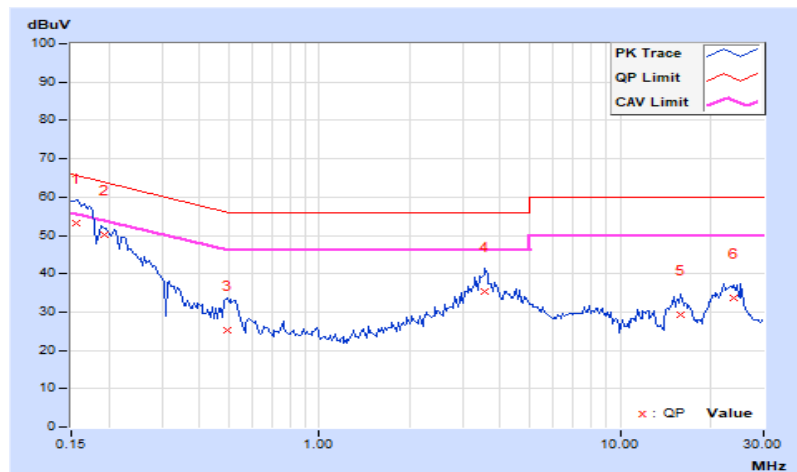



<b>RF Mode</b>	802.11be (EHT40)	<b>Channel</b>	CH 110 : 5550 MHz
<b>Frequency Range</b>	150 kHz ~ 30 MHz	<b>Detector Function &amp; Resolution Bandwidth</b>	Quasi-Peak (QP) / Average (AV), 9 kHz
<b>Input Power (System)</b>	120 Vac, 60 Hz	<b>Environmental Conditions</b>	24°C, 66% RH
<b>Tested By</b>	Sampson Chen		

Phase Of Power : Neutral (N)										
No	Frequency (MHz)	Correction Factor (dB)	Reading Value (dBuV)		Emission Level (dBuV)		Limit (dBuV)		Margin (dB)	
			Q.P.	AV.	Q.P.	AV.	Q.P.	AV.	Q.P.	AV.
1	0.15513	9.99	44.15	24.00	54.14	33.99	65.72	55.72	-11.58	-21.73
2	0.21581	9.99	35.01	12.62	45.00	22.61	62.98	52.98	-17.98	-30.37
3	0.49650	10.00	16.05	1.00	26.05	11.00	56.06	46.06	-30.01	-35.06
4	3.65421	10.14	25.56	16.31	35.70	26.45	56.00	46.00	-20.30	-19.55
5	15.39153	10.68	17.99	8.50	28.67	19.18	60.00	50.00	-31.33	-30.82
6	25.11609	10.99	20.31	17.79	31.30	28.78	60.00	50.00	-28.70	-21.22

**Remarks:**

1. Q.P. and AV. are abbreviations of quasi-peak and average individually.
2. The emission levels of other frequencies were very low against the limit.
3. Margin value = Emission level – Limit value
4. Correction factor = Insertion loss + Cable loss
5. Emission Level = Correction Factor + Reading Value

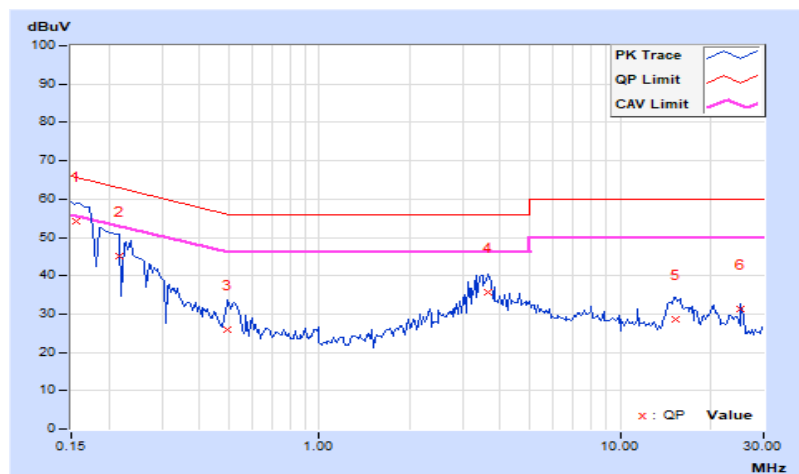

### For 2S2T

<b>RF Mode</b>	802.11be (EHT40)	<b>Channel</b>	CH 54 : 5270 MHz
<b>Frequency Range</b>	150 kHz ~ 30 MHz	<b>Detector Function &amp; Resolution Bandwidth</b>	Quasi-Peak (QP) / Average (AV), 9 kHz
<b>Input Power (System)</b>	120 Vac, 60 Hz	<b>Environmental Conditions</b>	20°C, 69% RH
<b>Tested By</b>	Sampson Chen		

Phase Of Power : Line (L)										
No	Frequency (MHz)	Correction Factor (dB)	Reading Value (dBuV)		Emission Level (dBuV)		Limit (dBuV)		Margin (dB)	
			Q.P.	AV.	Q.P.	AV.	Q.P.	AV.	Q.P.	AV.
1	0.15851	9.93	44.35	22.54	54.28	32.47	65.54	55.54	-11.26	-23.07
2	0.19469	9.93	41.10	22.70	51.03	32.63	63.83	53.83	-12.80	-21.20
3	0.50213	9.95	16.35	1.41	26.30	11.36	56.00	46.00	-29.70	-34.64
4	3.57501	10.10	25.50	18.10	35.60	28.20	56.00	46.00	-20.40	-17.80
5	15.88256	10.88	19.34	11.51	30.22	22.39	60.00	50.00	-29.78	-27.61
6	23.85237	11.29	23.41	17.51	34.70	28.80	60.00	50.00	-25.30	-21.20

### Remarks:

1. Q.P. and AV. are abbreviations of quasi-peak and average individually.
2. The emission levels of other frequencies were very low against the limit.
3. Margin value = Emission level – Limit value
4. Correction factor = Insertion loss + Cable loss
5. Emission Level = Correction Factor + Reading Value

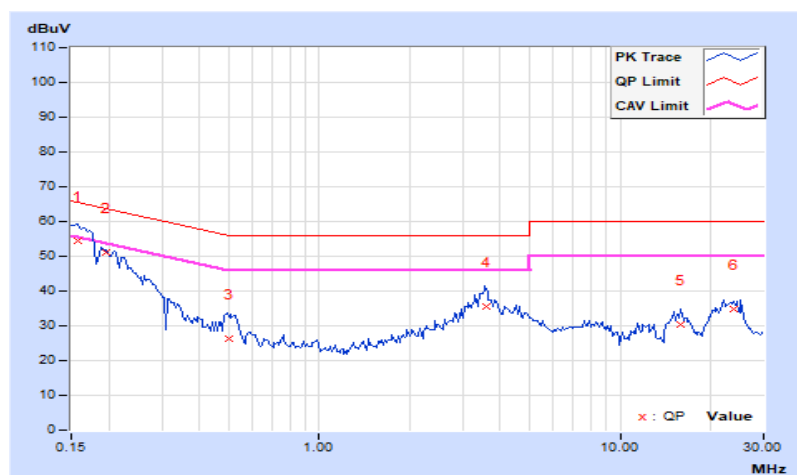

<b>RF Mode</b>	802.11be (EHT40)	<b>Channel</b>	CH 54 : 5270 MHz
<b>Frequency Range</b>	150 kHz ~ 30 MHz	<b>Detector Function &amp; Resolution Bandwidth</b>	Quasi-Peak (QP) / Average (AV), 9 kHz
<b>Input Power (System)</b>	120 Vac, 60 Hz	<b>Environmental Conditions</b>	20°C, 69% RH
<b>Tested By</b>	Sampson Chen		

Phase Of Power : Neutral (N)										
No	Frequency (MHz)	Correction Factor (dB)	Reading Value (dBuV)		Emission Level (dBuV)		Limit (dBuV)		Margin (dB)	
			Q.P.	AV.	Q.P.	AV.	Q.P.	AV.	Q.P.	AV.
1	0.15613	9.99	45.15	25.00	55.14	34.99	65.67	55.67	-10.53	-20.68
2	0.22581	9.99	34.01	11.62	44.00	21.61	62.60	52.60	-18.60	-30.99
3	0.50650	10.01	17.05	2.00	27.06	12.01	56.00	46.00	-28.94	-33.99
4	3.67421	10.15	26.56	17.31	36.71	27.46	56.00	46.00	-19.29	-18.54
5	15.40153	10.68	18.69	9.50	29.37	20.18	60.00	50.00	-30.63	-29.82
6	26.11609	11.01	19.31	15.79	30.32	26.80	60.00	50.00	-29.68	-23.20

**Remarks:**

1. Q.P. and AV. are abbreviations of quasi-peak and average individually.
2. The emission levels of other frequencies were very low against the limit.
3. Margin value = Emission level – Limit value
4. Correction factor = Insertion loss + Cable loss
5. Emission Level = Correction Factor + Reading Value

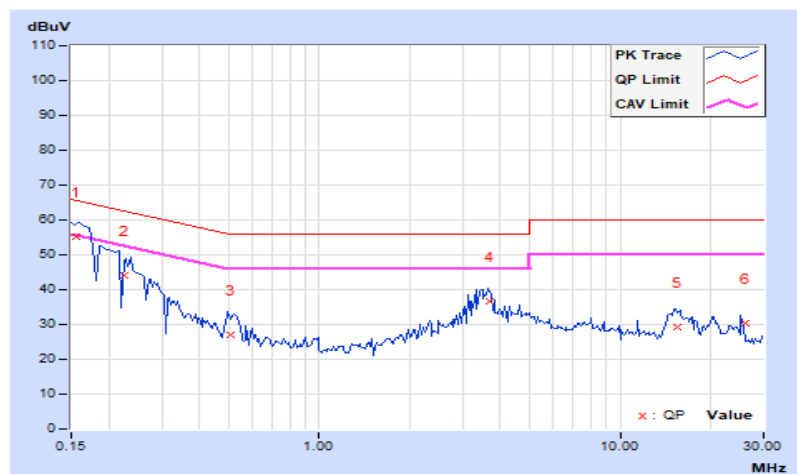

## 7.8 Unwanted Emissions below 1 GHz

Mode A  
For 1S1T

RF Mode	802.11be (EHT40)	Channel	CH 110 : 5550 MHz
Frequency Range	30 MHz ~ 1 GHz	Environmental Conditions	25°C, 65% RH
Tested By	Katina Lu		

Conducted Unwanted Emissions							
No.	Frequency (MHz)	Emission Level (dBUV/m)	Limit (dBUV/m)	Margin (dB)	Raw Value Chain 0 (dBm)	Correction Factor (dB)	EIRP Level (dBm)
1	64.92	31.28 PK	40	-8.72	-73.6	9.62	-63.98
2	159.74	31.94 PK	43.5	-11.56	-72.94	9.62	-63.32
3	352.52	32.75 PK	46	-13.25	-72.13	9.62	-62.51
4	508.69	32.27 PK	46	-13.73	-72.61	9.62	-62.99
5	769.02	33.21 PK	46	-12.79	-71.67	9.62	-62.05
6	851.95	33.74 PK	46	-12.26	-71.14	9.62	-61.52

Notes:

1. Margin value = Emission Level - Limit value
2. The frequency range 9 kHz ~ 30 MHz: all emissions are more than 20 dB below the limit, therefore do not be recorded in this report.

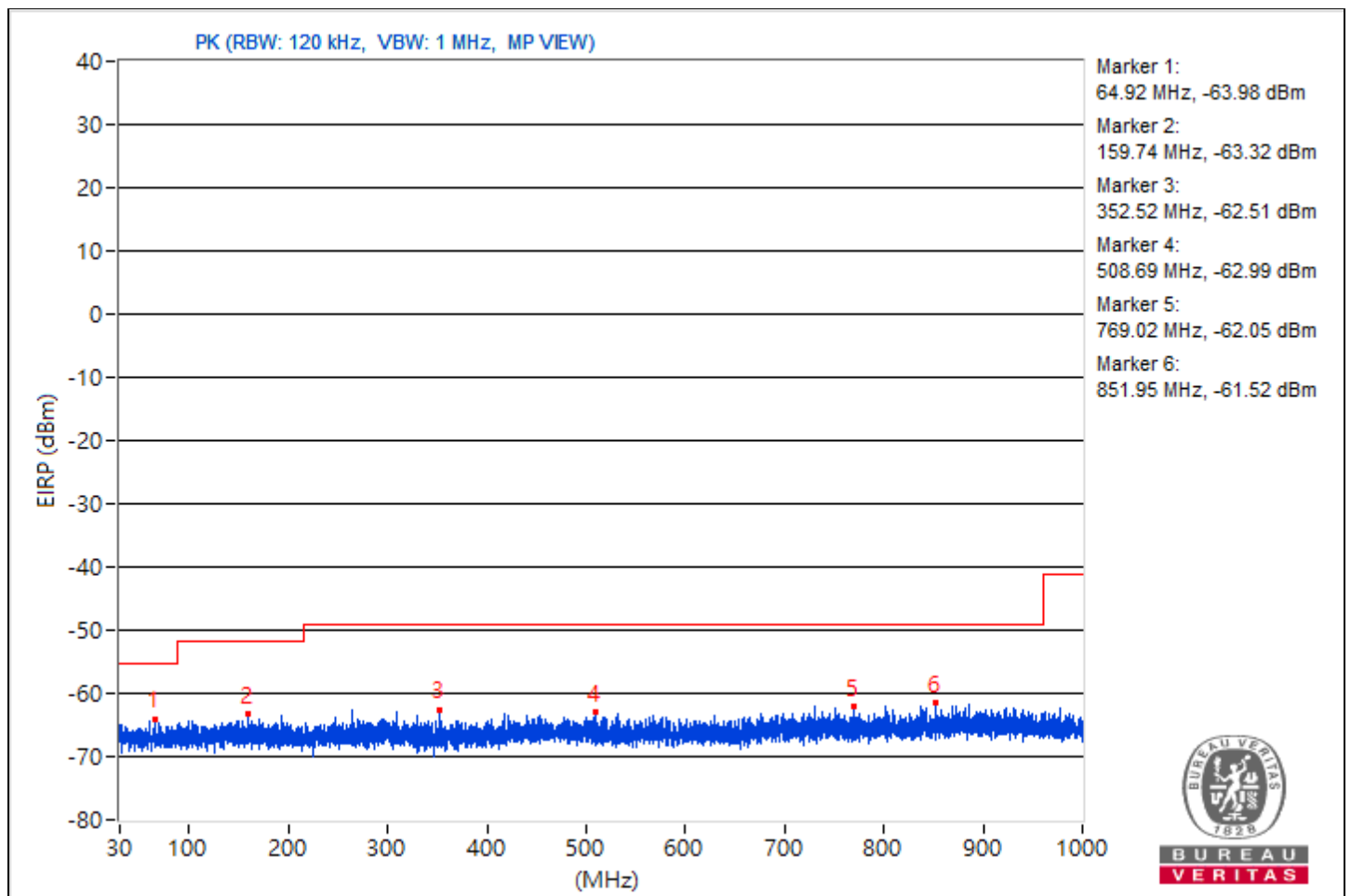

**For 2S2T**

RF Mode	802.11be (EHT40)	Channel	CH 54 : 5270 MHz
Frequency Range	30 MHz ~ 1 GHz	Environmental Conditions	25°C, 65% RH
Tested By	Katina Lu		

Conducted Unwanted Emissions								
No.	Frequency (MHz)	Emission Level (dBUV/m)	Limit (dBUV/m)	Margin (dB)	Raw Value Chain 0 (dBm)	Raw Value Chain 1 (dBm)	Correction Factor (dB)	EIRP Level (dBm)
1	55.46	33.74 PK	40	-6.26	-72.53	-76.76	9.62	-61.52
2	144.82	33.4 PK	43.5	-10.1	-76.67	-73.04	9.62	-61.86
3	325.37	34.51 PK	46	-11.49	-71.97	-75.5	9.62	-60.75
4	440.43	34.59 PK	46	-11.41	-75.95	-71.67	9.62	-60.67
5	741.98	35.42 PK	46	-10.58	-71.73	-73.36	9.62	-59.84
6	961.08	35.78 PK	54	-18.22	-75.42	-70.25	9.62	-59.48

Notes:

1. Margin value = Emission Level - Limit value
2. The frequency range 9 kHz ~ 30 MHz: all emissions are more than 20 dB below the limit, therefore do not be recorded in this report.

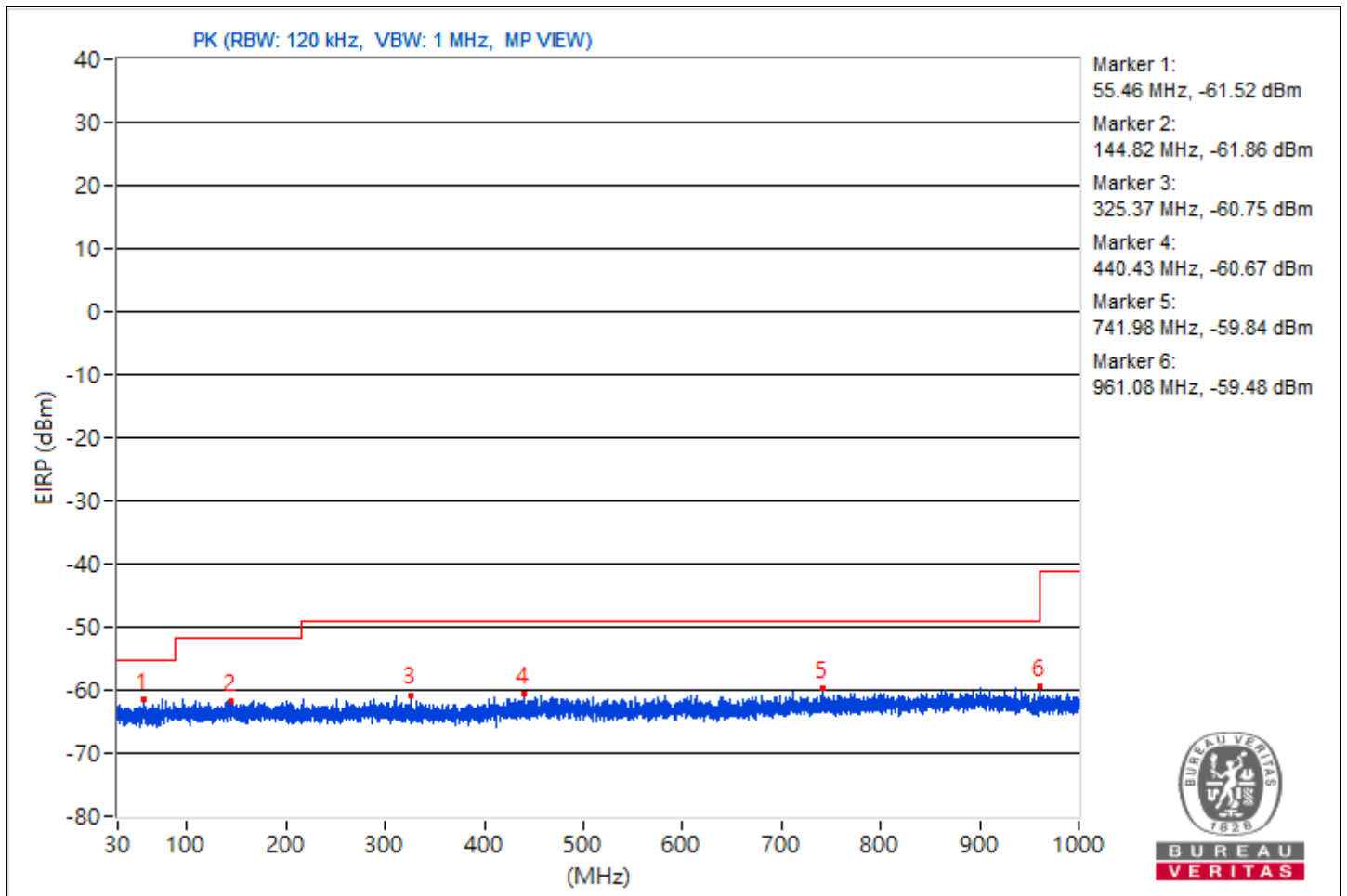

**Mode B**  
**For 1S1T**

<b>RF Mode</b>	802.11be (EHT40)	<b>Channel</b>	CH 110 : 5550 MHz
<b>Frequency Range</b>	30 MHz ~ 1 GHz	<b>Detector Function &amp; Bandwidth</b>	QP: RB=120kHz, DET=Quasi-Peak
<b>Input Power (System)</b>	120 Vac, 60 Hz	<b>Environmental Conditions</b>	25°C, 66% RH
<b>Tested By</b>	Sampson Chen		

Antenna Polarity & Test Distance : Horizontal at 3 m								
No	Frequency (MHz)	Emission Level (dBuV/m)	Limit (dBuV/m)	Margin (dB)	Antenna Height (m)	Table Angle (Degree)	Raw Value (dBuV)	Correction Factor (dB/m)
1	214.98	40.1 QP	43.5	-3.4	2.00 H	129	56.5	-16.4
2	239.37	42.1 QP	46.0	-3.9	1.00 H	360	56.6	-14.5
3	299.13	45.2 QP	46.0	-0.8	1.50 H	250	57.6	-12.4
4	326.09	40.9 QP	46.0	-5.1	1.00 H	333	52.4	-11.5
5	700.05	42.3 QP	46.0	-3.7	2.00 H	60	46.2	-3.9
6	840.21	40.5 QP	46.0	-5.5	1.50 H	290	42.1	-1.6

**Remarks:**

1. Emission Level(dBuV/m) = Raw Value(dBuV) + Correction Factor(dB/m)
2. Correction Factor(dB/m) = Antenna Factor(dB/m) + Cable Factor(dB) – Pre-Amplifier Factor(dB)
3. Margin value = Emission Level – Limit value
4. The other emission levels were very low against the limit of frequency range 30 MHz ~ 1 GHz.
5. The frequency range 9 kHz ~ 30 MHz: all emissions are more than 20 dB below the limit, therefore do not be recorded in this report.

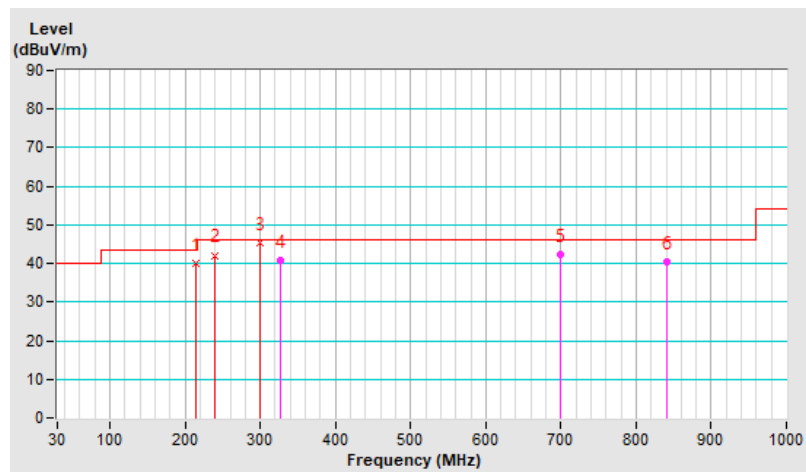

<b>RF Mode</b>	802.11be (EHT40)	<b>Channel</b>	CH 110 : 5550 MHz
<b>Frequency Range</b>	30 MHz ~ 1 GHz	<b>Detector Function &amp; Bandwidth</b>	QP: RB=120kHz, DET=Quasi-Peak
<b>Input Power (System)</b>	120 Vac, 60 Hz	<b>Environmental Conditions</b>	25°C, 66% RH
<b>Tested By</b>	Sampson Chen		

Antenna Polarity & Test Distance : Vertical at 3 m								
No	Frequency (MHz)	Emission Level (dBuV/m)	Limit (dBuV/m)	Margin (dB)	Antenna Height (m)	Table Angle (Degree)	Raw Value (dBuV)	Correction Factor (dB/m)
1	100.21	30.3 QP	43.5	-13.2	1.50 V	256	47.4	-17.1
2	143.98	28.5 QP	43.5	-15.0	2.00 V	255	41.5	-13.0
3	242.23	35.5 QP	46.0	-10.5	2.00 V	285	49.9	-14.4
4	300.10	40.5 QP	46.0	-5.5	2.00 V	295	52.9	-12.4
5	335.94	31.3 QP	46.0	-14.7	2.00 V	265	42.7	-11.4
6	700.05	39.5 QP	46.0	-6.5	2.00 V	255	43.4	-3.9

**Remarks:**

1. Emission Level(dBuV/m) = Raw Value(dBuV) + Correction Factor(dB/m)
2. Correction Factor(dB/m) = Antenna Factor(dB/m) + Cable Factor(dB) – Pre-Amplifier Factor(dB)
3. Margin value = Emission Level – Limit value
4. The other emission levels were very low against the limit of frequency range 30 MHz ~ 1 GHz.
5. The frequency range 9 kHz ~ 30 MHz: all emissions are more than 20 dB below the limit, therefore do not be recorded in this report.

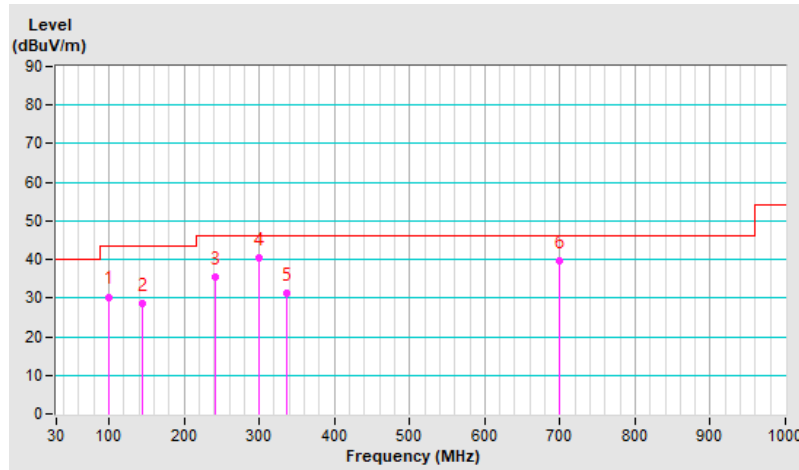

For 2S2T

<b>RF Mode</b>	802.11be (EHT40)	<b>Channel</b>	CH 54 : 5270 MHz
<b>Frequency Range</b>	30 MHz ~ 1 GHz	<b>Detector Function &amp; Bandwidth</b>	QP: RB=120kHz, DET=Quasi-Peak
<b>Input Power (System)</b>	120 Vac, 60 Hz	<b>Environmental Conditions</b>	20°C, 70% RH
<b>Tested By</b>	Sampson Chen		

Antenna Polarity & Test Distance : Horizontal at 3 m								
No	Frequency (MHz)	Emission Level (dBuV/m)	Limit (dBuV/m)	Margin (dB)	Antenna Height (m)	Table Angle (Degree)	Raw Value (dBuV)	Correction Factor (dB/m)
1	213.61	39.2 QP	43.5	-4.3	2.00 H	150	60.6	-21.4
2	240.45	42.3 QP	46.0	-3.7	1.00 H	351	61.7	-19.4
<b>3</b>	<b>300.17</b>	<b>45.3 QP</b>	<b>46.0</b>	<b>-0.7</b>	<b>1.00 H</b>	<b>208</b>	<b>62.7</b>	<b>-17.4</b>
4	325.09	40.7 QP	46.0	-5.3	1.50 H	306	57.3	-16.6
5	700.73	42.5 QP	46.0	-3.5	2.00 H	50	51.5	-9.0
6	841.02	40.6 QP	46.0	-5.4	1.50 H	280	47.3	-6.7

Remarks:

1. Emission Level(dBuV/m) = Raw Value(dBuV) + Correction Factor(dB/m)
2. Correction Factor(dB/m) = Antenna Factor(dB/m) + Cable Factor(dB) – Pre-Amplifier Factor(dB)
3. Margin value = Emission Level – Limit value
4. The other emission levels were very low against the limit of frequency range 30 MHz ~ 1 GHz.
5. The frequency range 9 kHz ~ 30 MHz: all emissions are more than 20 dB below the limit, therefore do not be recorded in this report.

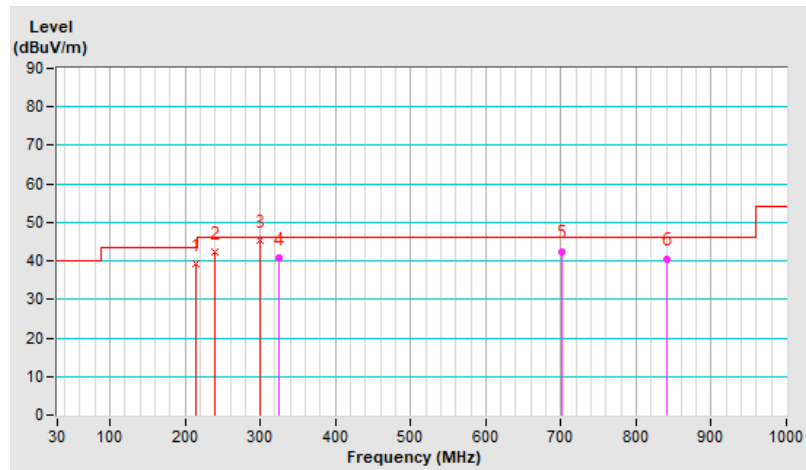



<b>RF Mode</b>	802.11be (EHT40)	<b>Channel</b>	CH 54 : 5270 MHz
<b>Frequency Range</b>	30 MHz ~ 1 GHz	<b>Detector Function &amp; Bandwidth</b>	QP: RB=120kHz, DET=Quasi-Peak
<b>Input Power (System)</b>	120 Vac, 60 Hz	<b>Environmental Conditions</b>	20°C, 70% RH
<b>Tested By</b>	Sampson Chen		

Antenna Polarity & Test Distance : Vertical at 3 m								
No	Frequency (MHz)	Emission Level (dBuV/m)	Limit (dBuV/m)	Margin (dB)	Antenna Height (m)	Table Angle (Degree)	Raw Value (dBuV)	Correction Factor (dB/m)
1	101.26	30.6 QP	43.5	-12.9	1.50 V	270	52.6	-22.0
2	144.76	29.6 QP	43.5	-13.9	2.00 V	260	47.6	-18.0
3	243.43	35.1 QP	46.0	-10.9	2.00 V	290	54.4	-19.3
4	301.29	40.3 QP	46.0	-5.7	1.50 V	265	57.7	-17.4
5	337.17	31.2 QP	46.0	-14.8	1.00 V	270	47.7	-16.5
6	701.31	39.9 QP	46.0	-6.1	2.00 V	290	48.9	-9.0

**Remarks:**

1. Emission Level(dBuV/m) = Raw Value(dBuV) + Correction Factor(dB/m)
2. Correction Factor(dB/m) = Antenna Factor(dB/m) + Cable Factor(dB) – Pre-Amplifier Factor(dB)
3. Margin value = Emission Level – Limit value
4. The other emission levels were very low against the limit of frequency range 30 MHz ~ 1 GHz.
5. The frequency range 9 kHz ~ 30 MHz: all emissions are more than 20 dB below the limit, therefore do not be recorded in this report.

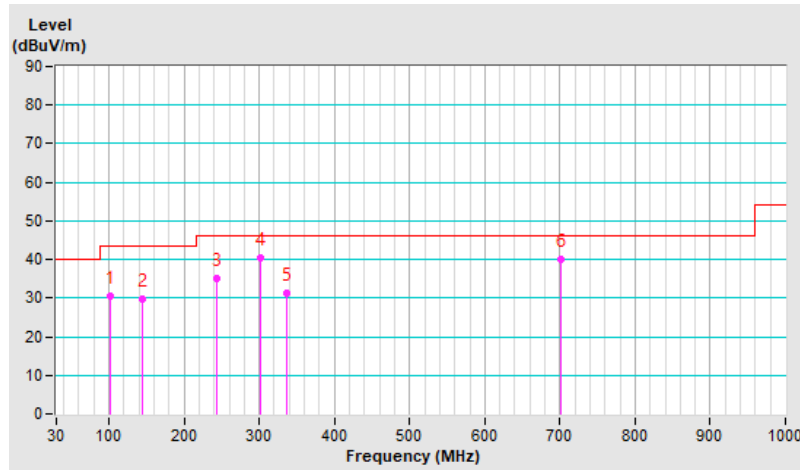

## 7.9 Unwanted Emissions above 1 GHz

### Mode A

### For 1S1T

### 802.11be (EHT20) - Channel 52

#### Conducted spurious emission table

No.	Frequency (MHz)	Emission Level (dBuV/m)	Limit (dBuV/m)	Margin (dB)	Raw Value (dBm)	Correction Factor (dB)	EIRP Level (dBm)
1	3510.93	61.35 PK	74	-12.65	-38.83	4.92	-33.91
2	3514.06	39.14 AV	54	-14.86	-61.04	4.92	-56.12
3	#7018.75	62.24 PK	68.2	-5.96	-37.94	4.92	-33.02
4	#10503.12	63.38 PK	68.2	-4.82	-36.8	4.92	-31.88
5	15795.68	52.37 PK	74	-21.63	-47.81	4.92	-42.89
6	15768.37	41.63 AV	54	-12.37	-58.55	4.92	-53.63

#### Remarks:

1. Margin value = Emission Level – Limit value
2. The other emission levels were very low against the limit.
3. " # " : The frequency is out of the restricted band.



BUREAU VERITAS

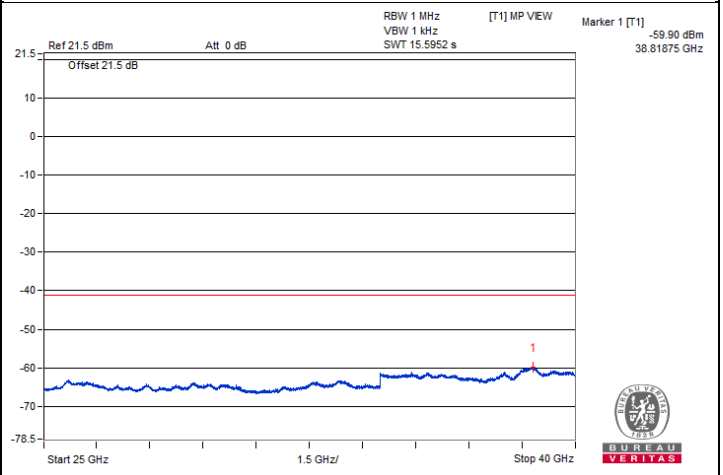
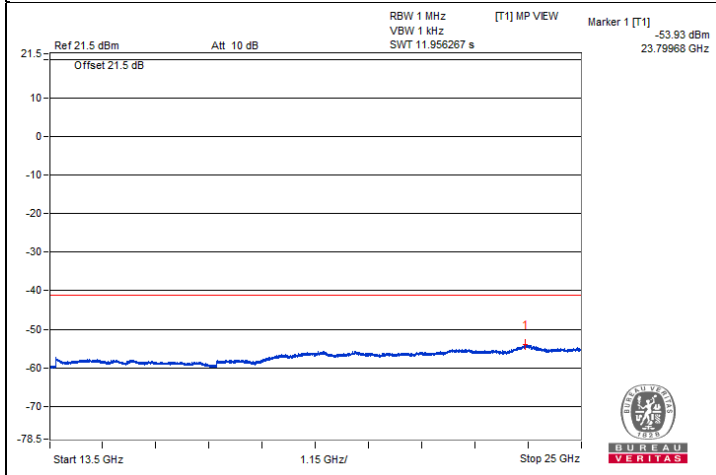
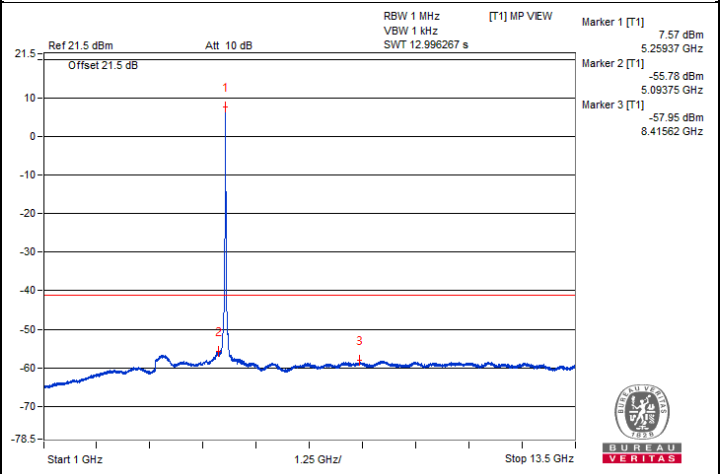
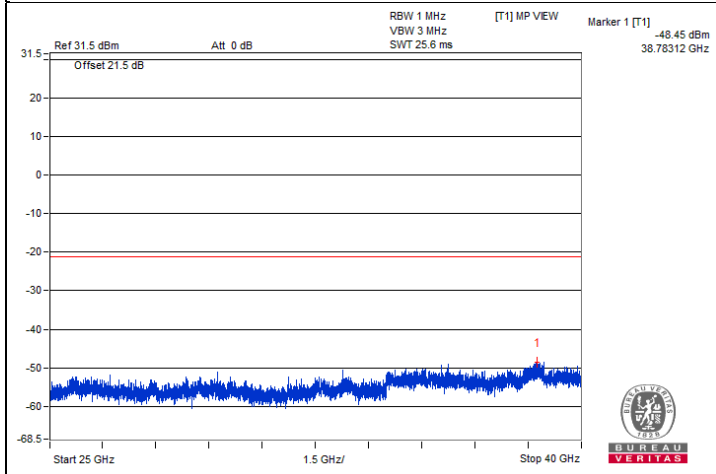
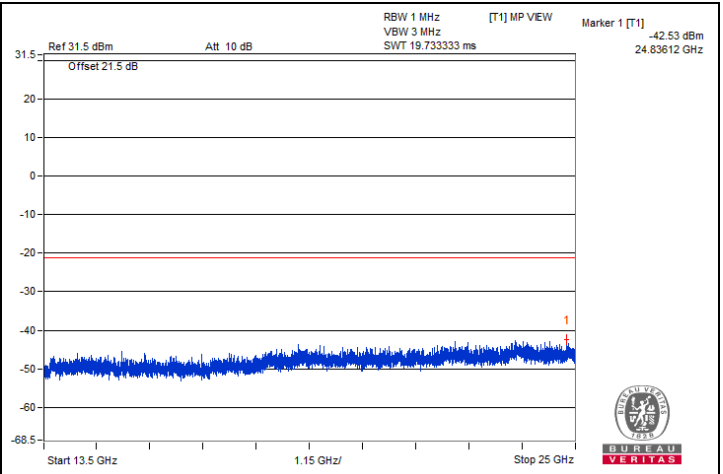
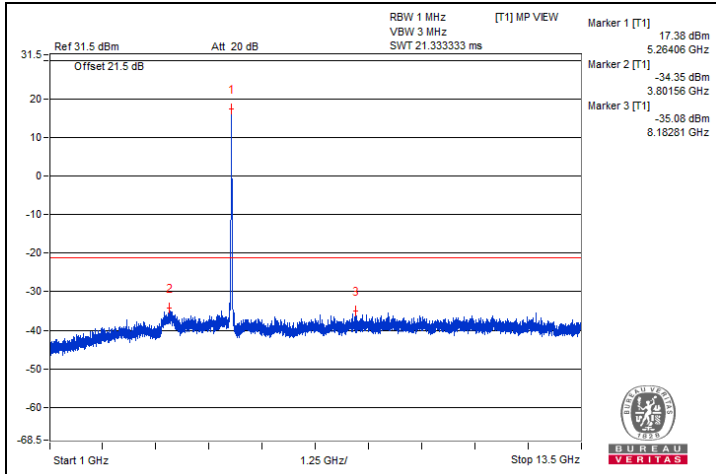

**Bandedge table**

No.	Frequency (MHz)	Emission Level (dBuV/m)	Limit (dBuV/m)	Margin (dB)	Raw Value (dBm)	Correction Factor (dB)	EIRP Level (dBm)
1	5441.7	62.33 PK	74	-11.67	-37.85	4.92	-32.93
2	5441.42	50.39 AV	54	-3.61	-49.79	4.92	-44.87

Remarks:

1. Margin value = Emission Level – Limit value
2. The other emission levels were very low against the limit.

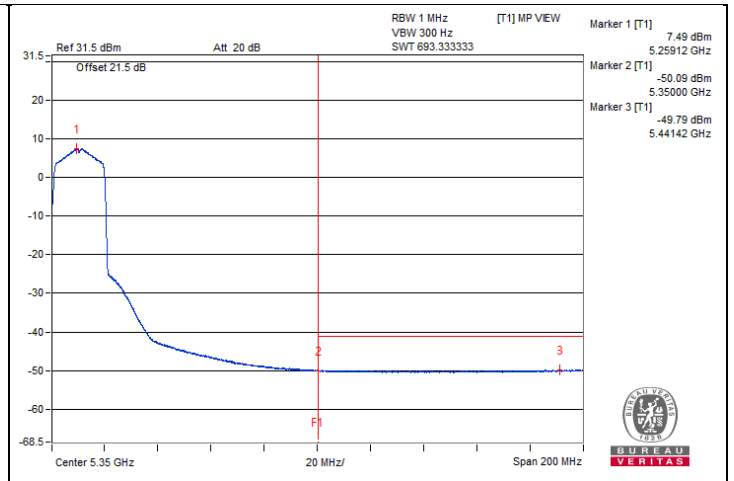
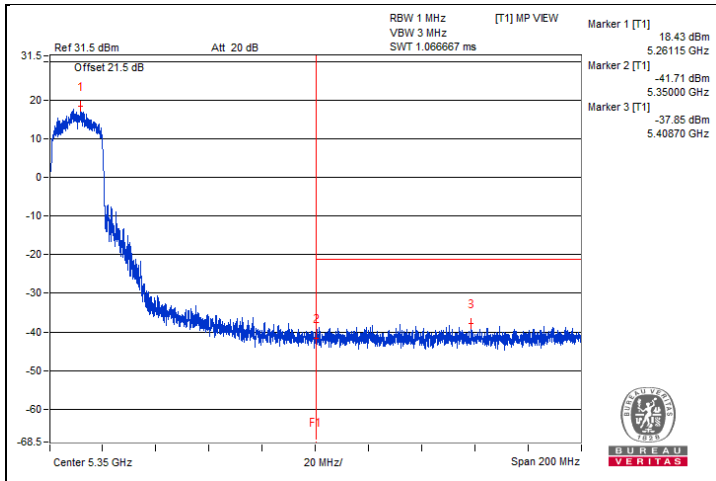

### 802.11be (EHT20) - Channel 60

#### Conducted spurious emission table

No.	Frequency (MHz)	Emission Level (dBuV/m)	Limit (dBuV/m)	Margin (dB)	Raw Value (dBm)	Correction Factor (dB)	EIRP Level (dBm)
1	3550.62	61.64 PK	74	-12.36	-38.54	4.92	-33.62
2	3553.12	39.35 AV	54	-14.65	-60.83	4.92	-55.91
3	#7067.18	62.61 PK	68.2	-5.59	-37.57	4.92	-32.65
4	15910.12	52.22 PK	74	-21.78	-47.96	4.92	-43.04
5	15910.68	41.48 AV	54	-12.52	-58.7	4.92	-53.78

Remarks:

1. Margin value = Emission Level – Limit value
2. The other emission levels were very low against the limit.
3. " # " : The frequency is out of the restricted band.



BUREAU  
VERITAS

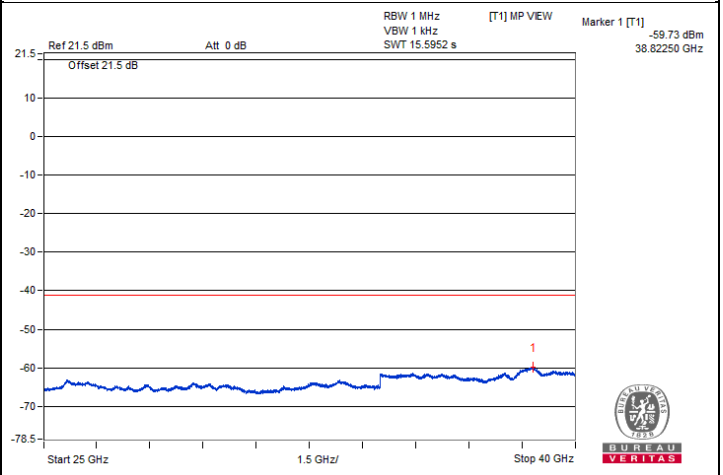
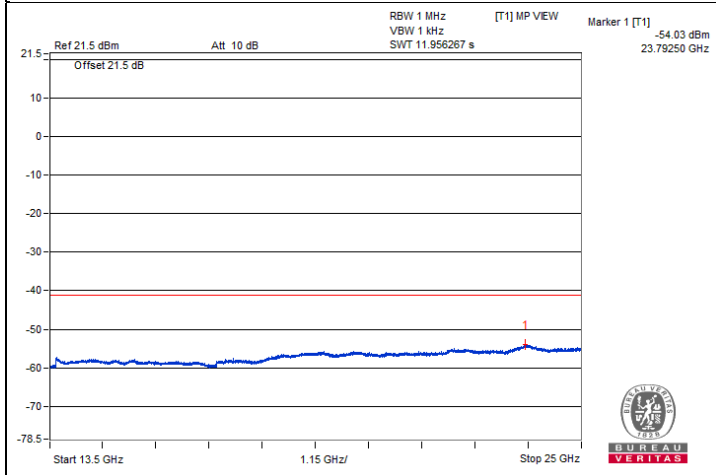
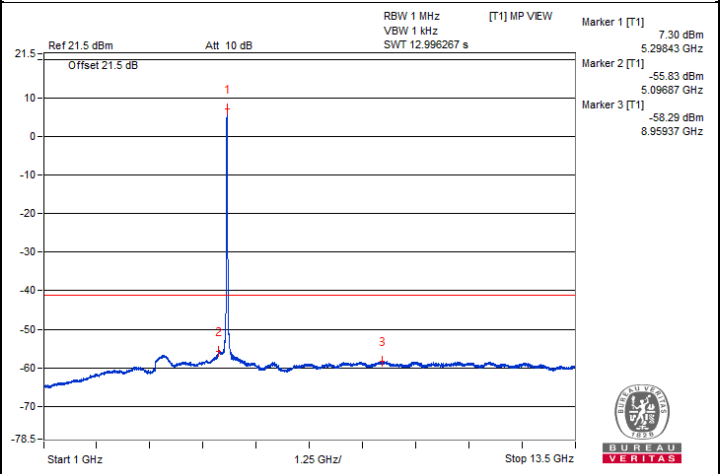
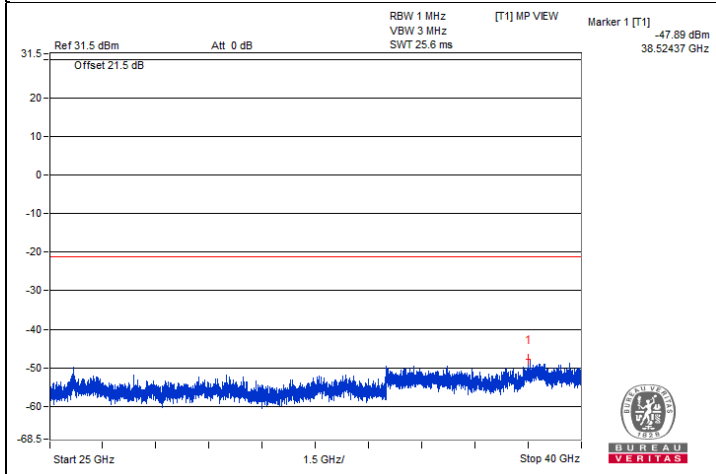
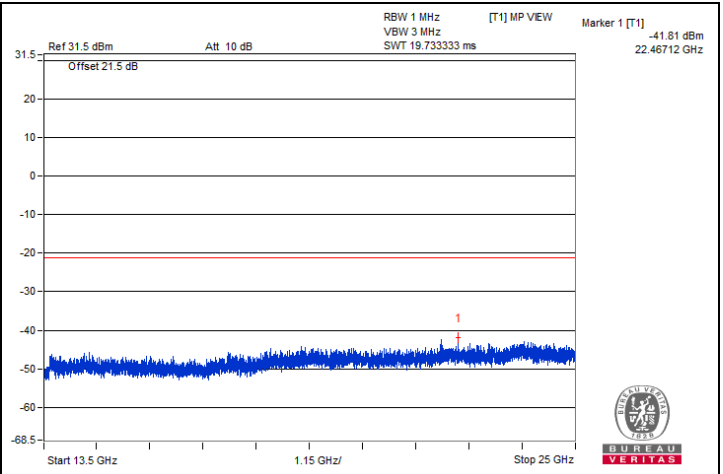
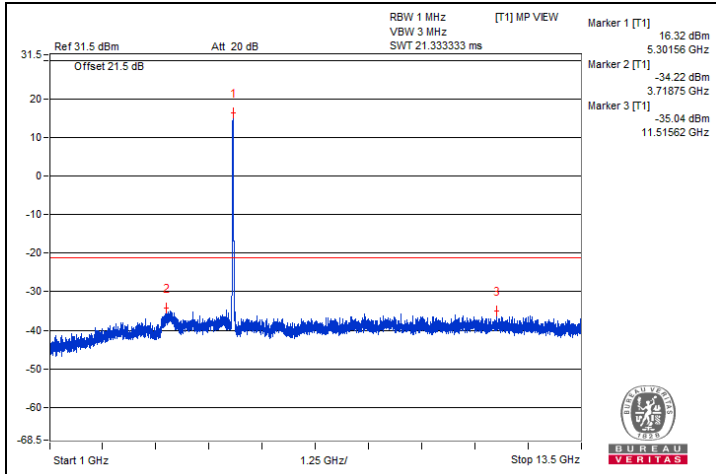

**Bandedge table**

No.	Frequency (MHz)	Emission Level (dBuV/m)	Limit (dBuV/m)	Margin (dB)	Raw Value (dBm)	Correction Factor (dB)	EIRP Level (dBm)
1	5449.45	63.33 PK	74	-10.67	-36.85	4.92	-31.93
2	5449.17	51.65 AV	54	-2.35	-48.53	4.92	-43.61

Remarks:

1. Margin value = Emission Level – Limit value
2. The other emission levels were very low against the limit.

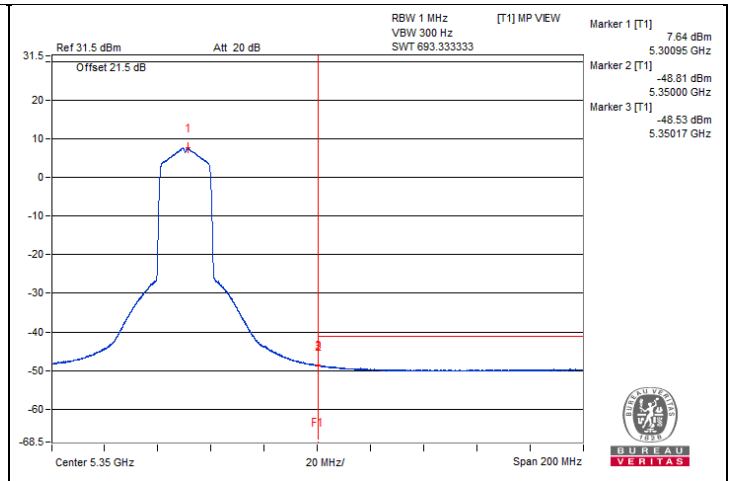
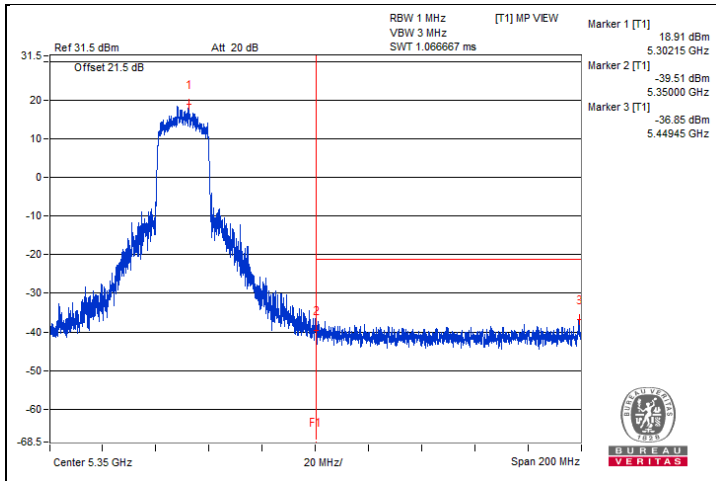

### 802.11be (EHT20) - Channel 64

#### Conducted spurious emission table

No.	Frequency (MHz)	Emission Level (dBuV/m)	Limit (dBuV/m)	Margin (dB)	Raw Value (dBm)	Correction Factor (dB)	EIRP Level (dBm)
1	3559.62	60.84 PK	74	-13.16	-39.34	4.92	-34.42
2	3559.37	39.44 AV	54	-14.56	-60.74	4.92	-55.82
3	#7093.75	62.35 PK	68.2	-5.85	-37.83	4.92	-32.91
4	10648.87	63.11 PK	74	-10.89	-37.07	4.92	-32.15
5	10648.43	41.36 AV	54	-12.64	-58.82	4.92	-53.90
6	15976.81	53.08 PK	74	-20.92	-47.1	4.92	-42.18
7	15973.93	41.63 AV	54	-12.37	-58.55	4.92	-53.63

Remarks:

1. Margin value = Emission Level – Limit value
2. The other emission levels were very low against the limit.
3. " # " : The frequency is out of the restricted band.



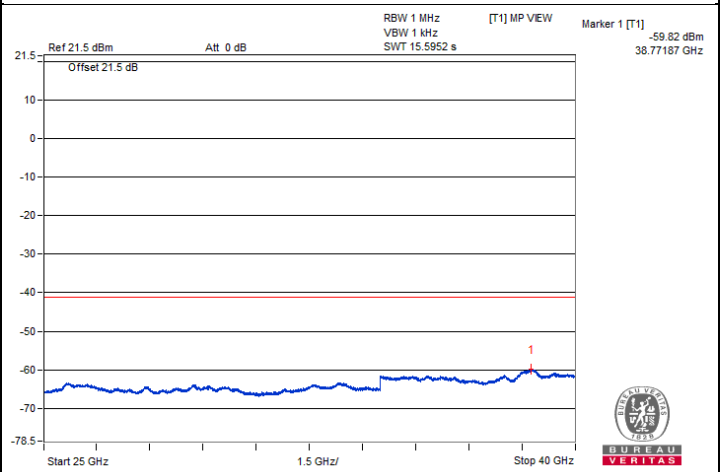
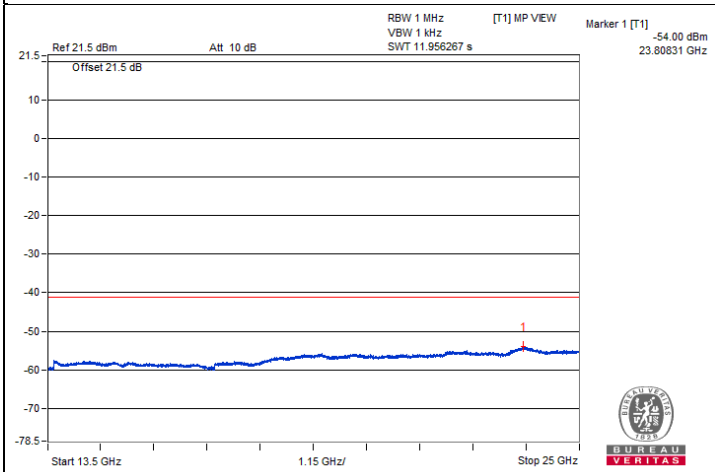
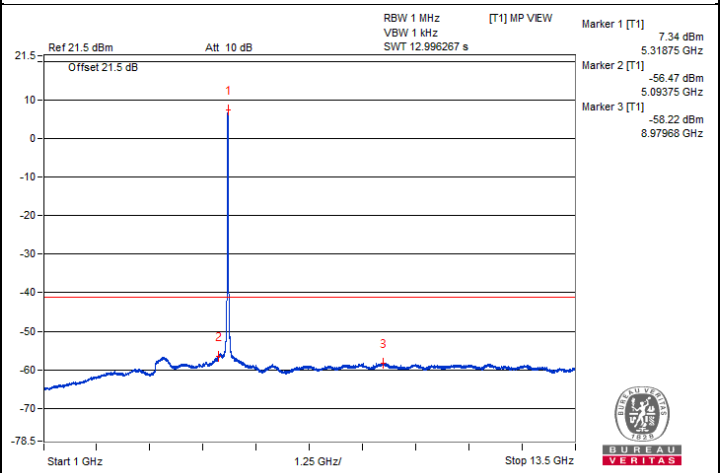
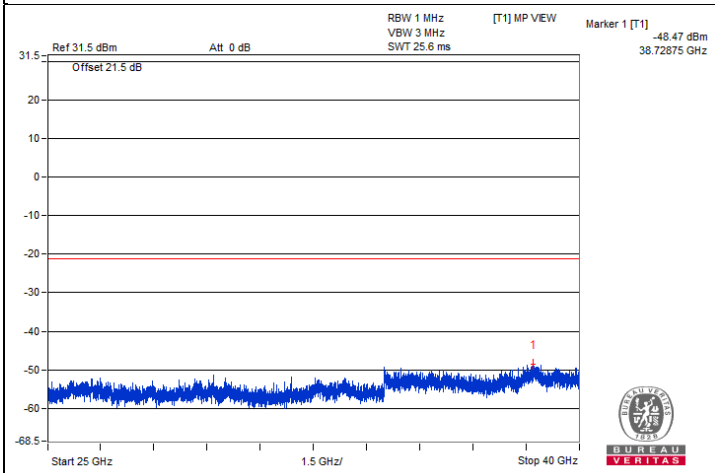
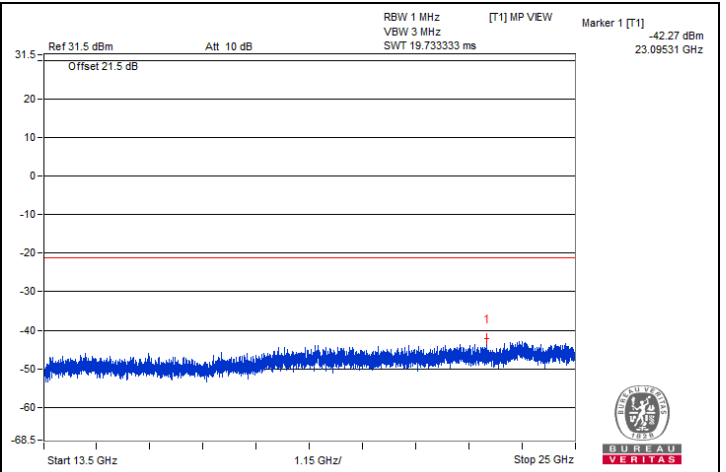
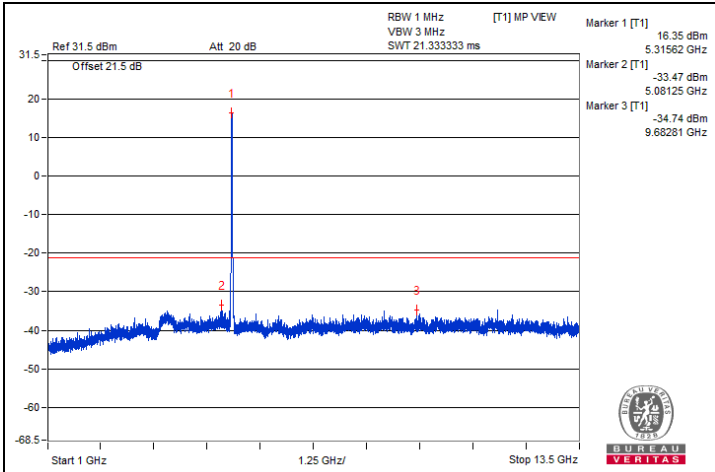

**Bandedge table**

No.	Frequency (MHz)	Emission Level (dBuV/m)	Limit (dBuV/m)	Margin (dB)	Raw Value (dBm)	Correction Factor (dB)	EIRP Level (dBm)
1	5350.2	69.17 PK	74	-4.83	-31.01	4.92	-26.09
2	5350.05	53.78 AV	54	-0.22	-46.4	4.92	-41.48

Remarks:

1. Margin value = Emission Level – Limit value
2. The other emission levels were very low against the limit.

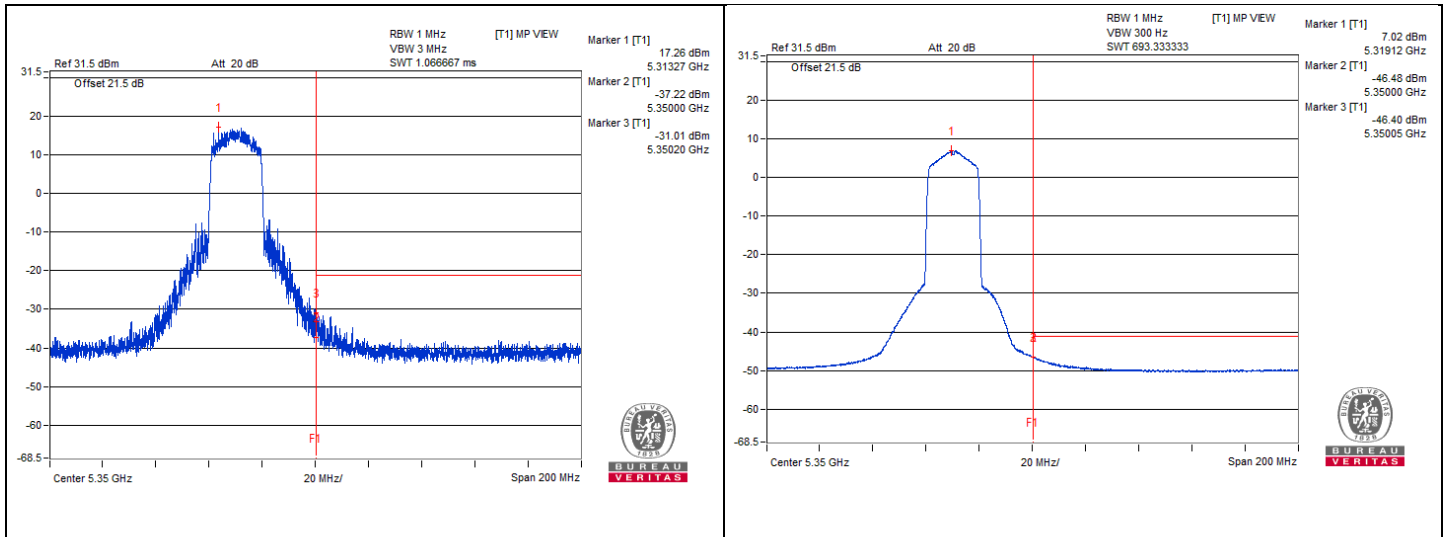

## 802.11be (EHT20) - Channel 100

### Conducted spurious emission table

No.	Frequency (MHz)	Emission Level (dBuV/m)	Limit (dBuV/m)	Margin (dB)	Raw Value (dBm)	Correction Factor (dB)	EIRP Level (dBm)
1	3665.87	63.82 PK	74	-10.18	-36.36	4.92	-31.44
2	3665.62	42.75 AV	54	-11.25	-57.43	4.92	-52.51
3	7342.18	63.01 PK	74	-10.99	-37.17	4.92	-32.25
4	7342.56	40.77 AV	54	-13.23	-59.41	4.92	-54.49
5	11009.18	63.14 PK	74	-10.86	-37.04	4.92	-32.12
6	11009.37	41.31 AV	54	-12.69	-58.87	4.92	-53.95
7	#16505.81	52.62 PK	68.2	-15.58	-47.56	4.92	-42.64

#### Remarks:

1. Margin value = Emission Level – Limit value
2. The other emission levels were very low against the limit.
3. " # " : The frequency is out of the restricted band.

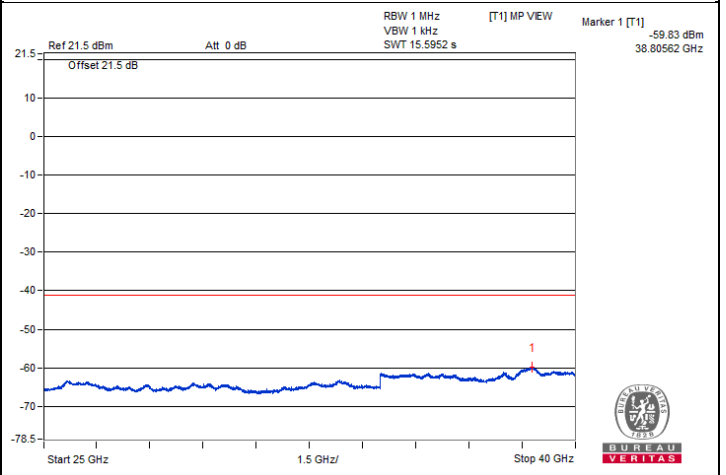
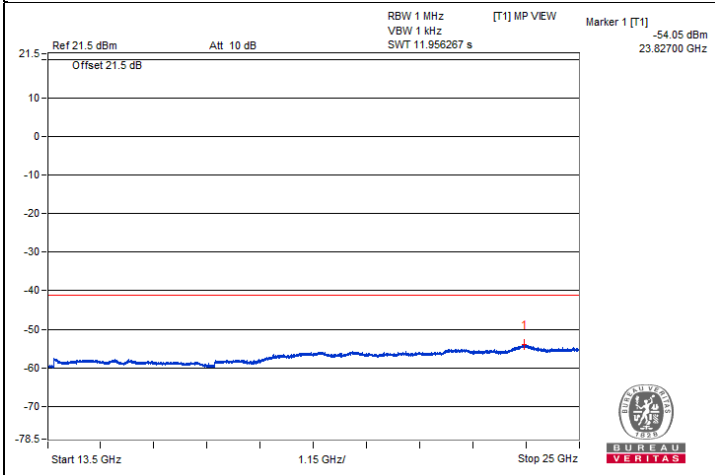
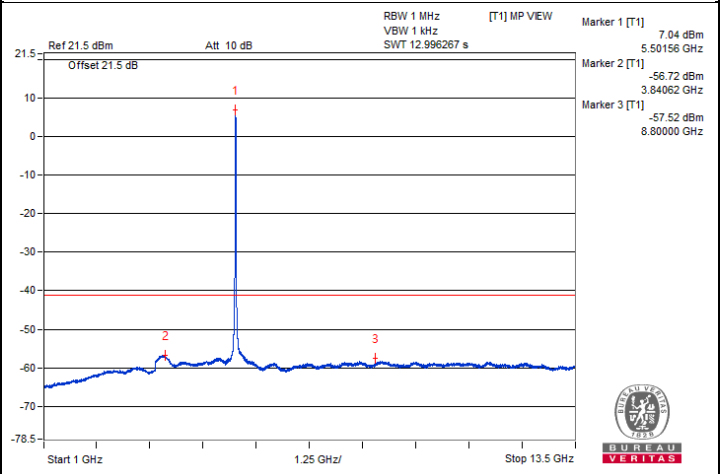
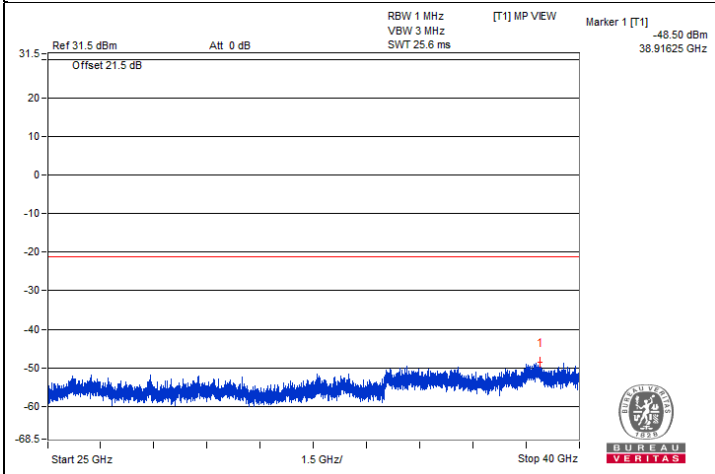
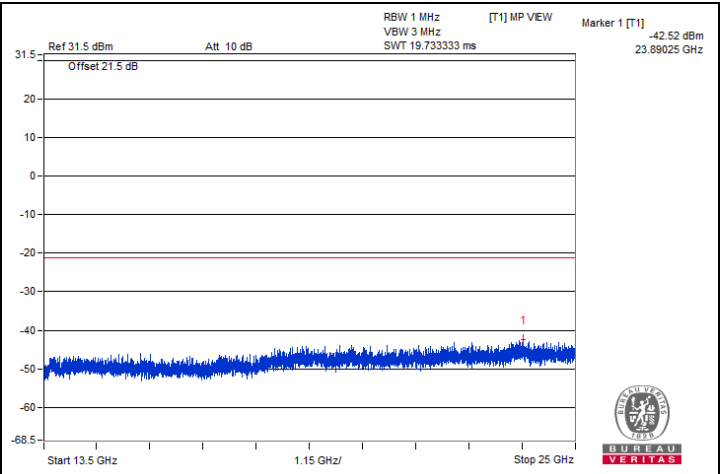
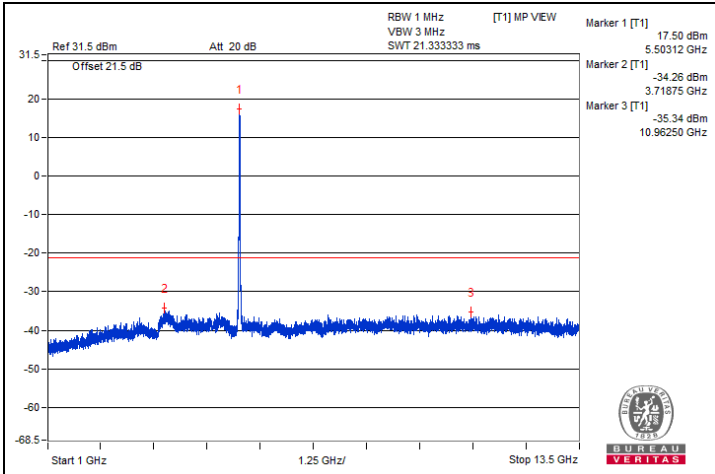

**Bandedge table**

No.	Frequency (MHz)	Emission Level (dBuV/m)	Limit (dBuV/m)	Margin (dB)	Raw Value (dBm)	Correction Factor (dB)	EIRP Level (dBm)
1	5455.78	63.49 PK	74	-10.51	-36.69	4.92	-31.77
2	5459.75	48.01 AV	54	-5.99	-52.17	4.92	-47.25
3	#5470	67.42 PK	68.2	-0.78	-32.76	4.92	-27.84

Remarks:

1. Margin value = Emission Level – Limit value
2. The other emission levels were very low against the limit.
3. " # " : The frequency is out of the restricted band.

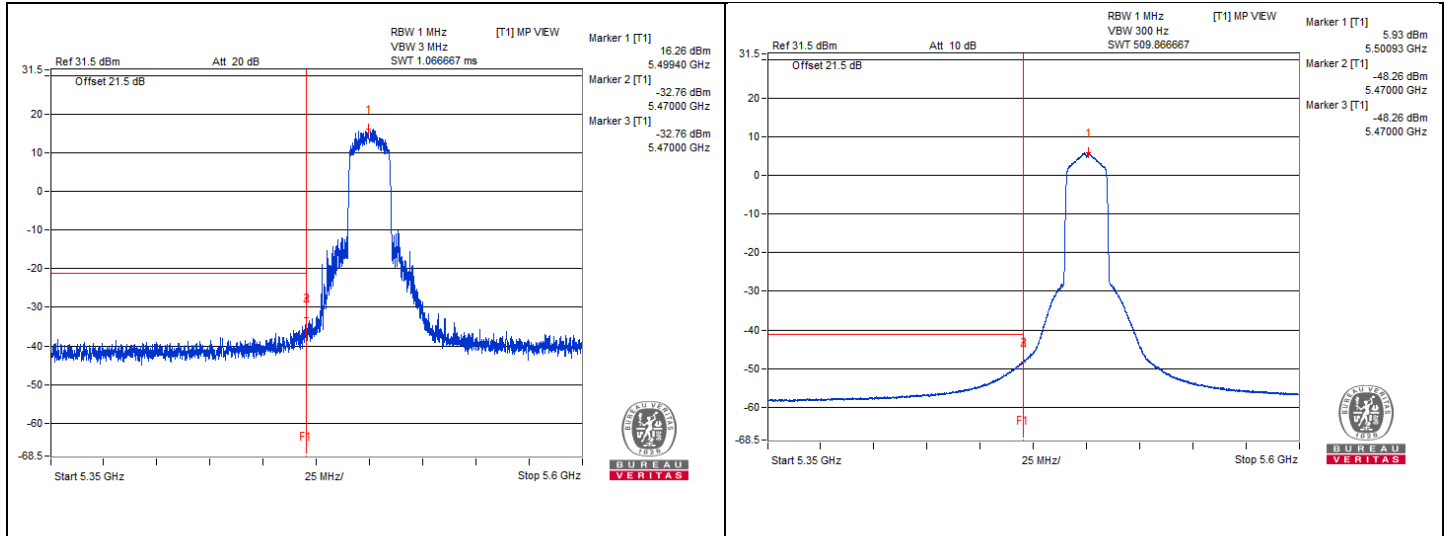

## 802.11be (EHT20) - Channel 116

### Conducted spurious emission table

No.	Frequency (MHz)	Emission Level (dBuV/m)	Limit (dBuV/m)	Margin (dB)	Raw Value (dBm)	Correction Factor (dB)	EIRP Level (dBm)
1	3734.68	64.55 PK	74	-9.45	-35.63	4.92	-30.71
2	3735.93	43.07 AV	54	-10.93	-57.11	4.92	-52.19
3	7454.68	61.66 PK	74	-12.34	-38.52	4.92	-33.60
4	7454.5	40.39 AV	54	-13.61	-59.79	4.92	-54.87
5	11179.68	62.4 PK	74	-11.6	-37.78	4.92	-32.86
6	11177.18	40.98 AV	54	-13.02	-59.2	4.92	-54.28
7	#16737.25	52.55 PK	68.2	-15.65	-47.63	4.92	-42.71

#### Remarks:

1. Margin value = Emission Level – Limit value
2. The other emission levels were very low against the limit.
3. " # " : The frequency is out of the restricted band.

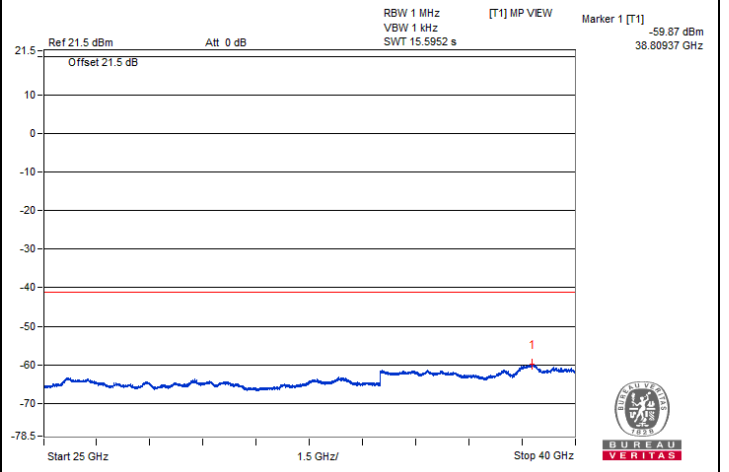
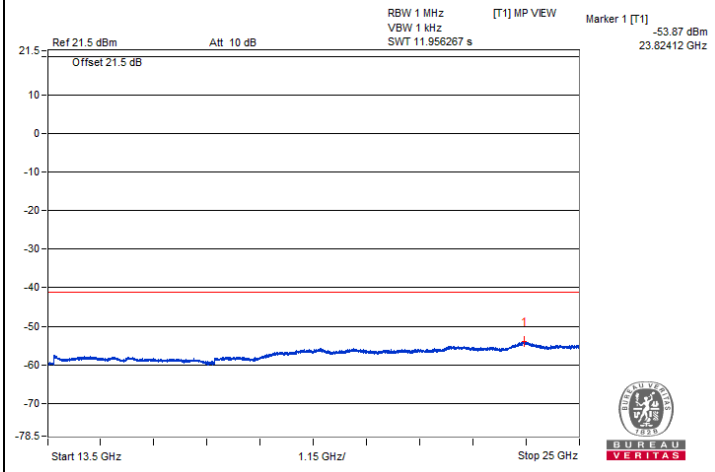
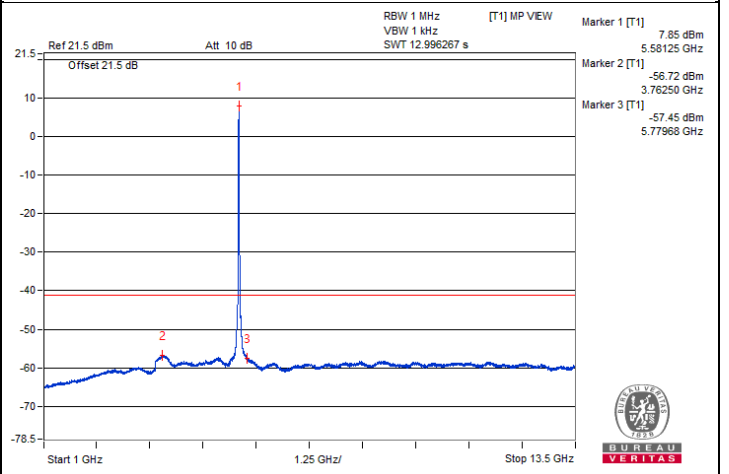
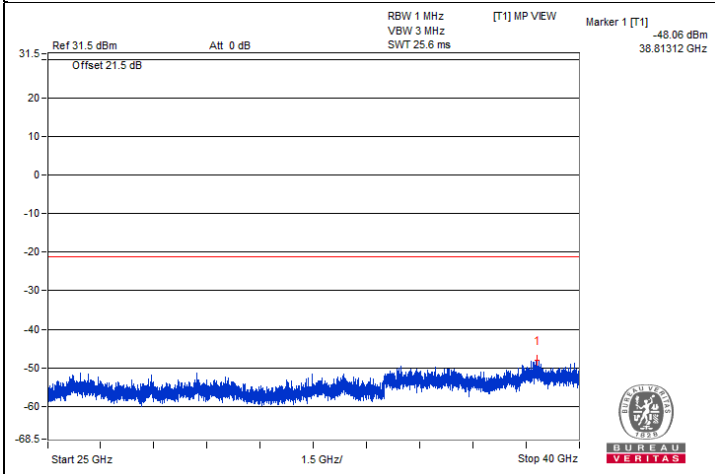
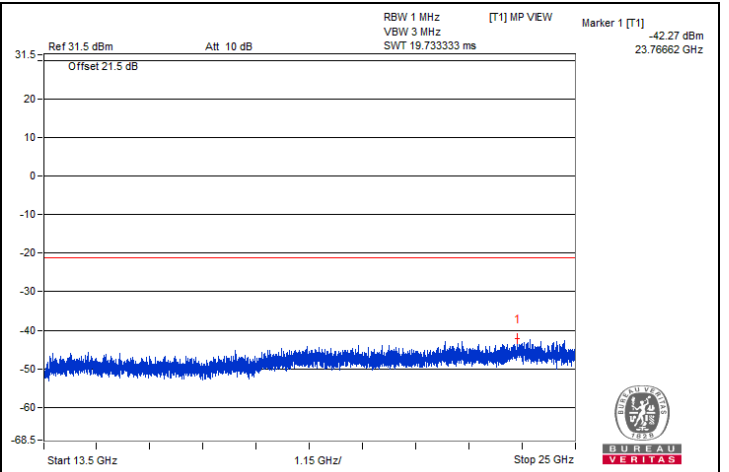
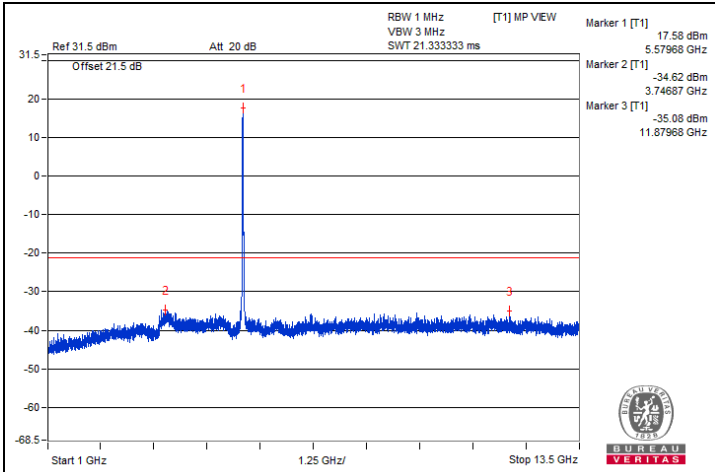

**Bandedge table**

No.	Frequency (MHz)	Emission Level (dBUV/m)	Limit (dBUV/m)	Margin (dB)	Raw Value (dBm)	Correction Factor (dB)	EIRP Level (dBm)
1	#5784.9	63.65 PK	68.2	-4.55	-36.53	4.92	-31.61

Remarks:

1. Margin value = Emission Level – Limit value
2. The other emission levels were very low against the limit.
3. " # " : The frequency is out of the restricted band.

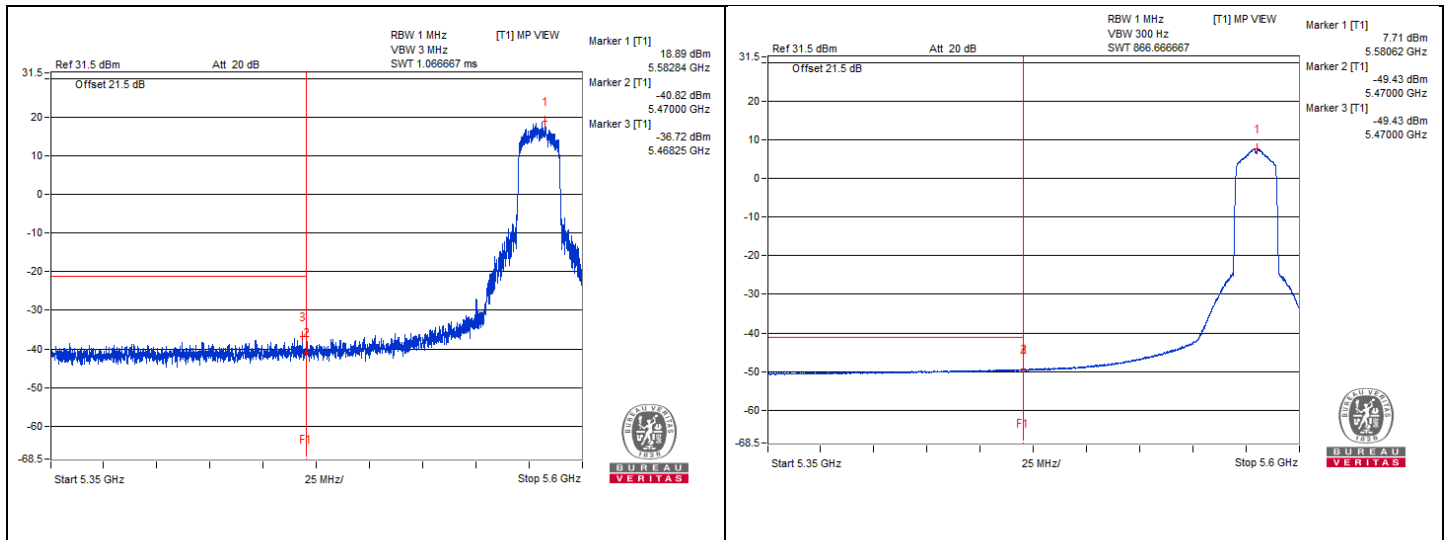



## 802.11be (EHT20) - Channel 140

### Conducted spurious emission table

No.	Frequency (MHz)	Emission Level (dBuV/m)	Limit (dBuV/m)	Margin (dB)	Raw Value (dBm)	Correction Factor (dB)	EIRP Level (dBm)
1	3812.5	65.35 PK	74	-8.65	-34.83	4.92	-29.91
2	3810.93	43.4 AV	54	-10.6	-56.78	4.92	-51.86
3	7607.5	62.88 PK	74	-11.12	-37.3	4.92	-32.38
4	7606.25	40.9 AV	54	-13.1	-59.28	4.92	-54.36
5	11410.93	63.43 PK	74	-10.57	-36.75	4.92	-31.83
6	11404.68	41.36 AV	54	-12.64	-58.82	4.92	-53.90
7	#17108.12	52.07 PK	68.2	-16.13	-48.11	4.92	-43.19

#### Remarks:

1. Margin value = Emission Level – Limit value
2. The other emission levels were very low against the limit.
3. " # " : The frequency is out of the restricted band.

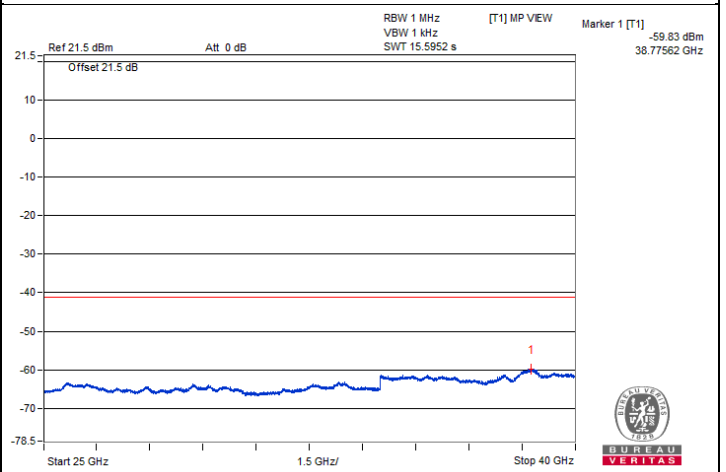
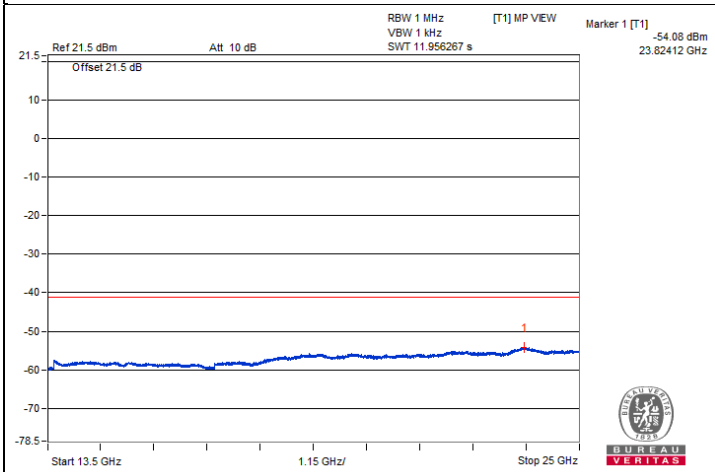
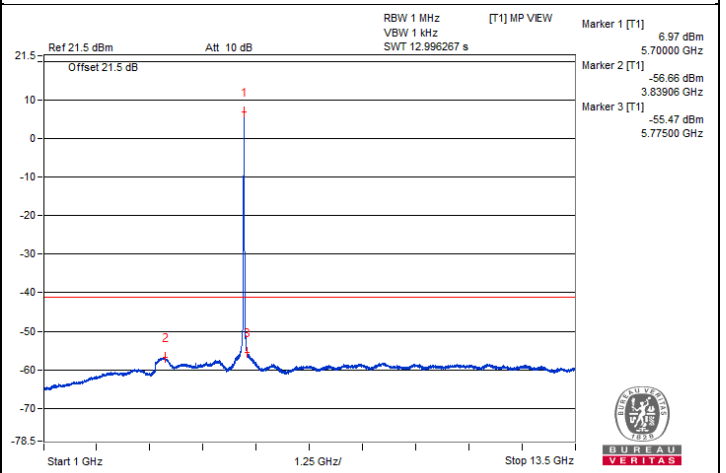
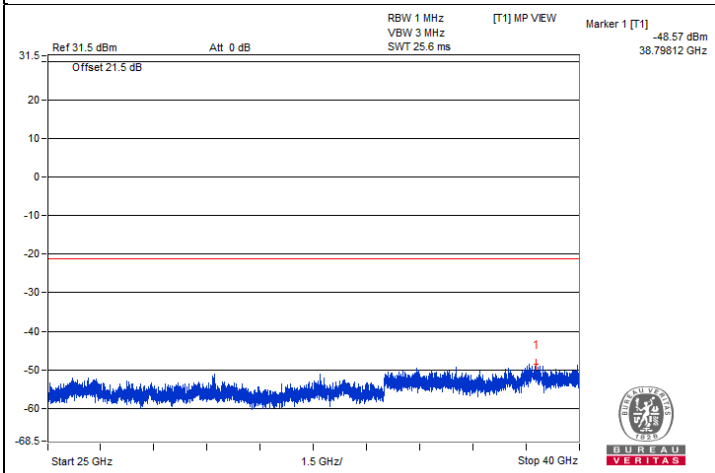
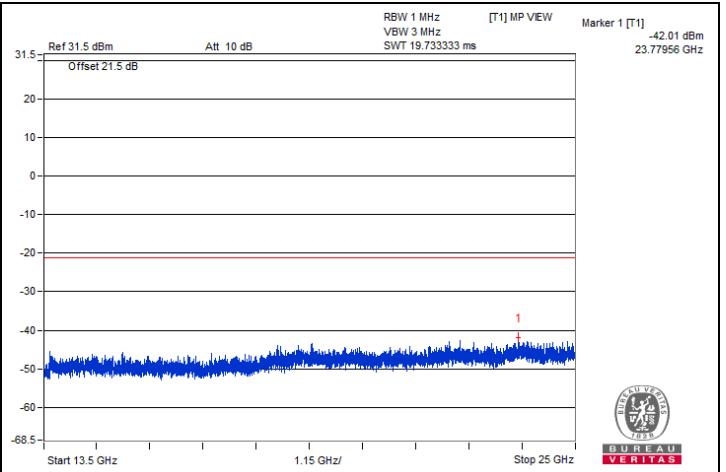
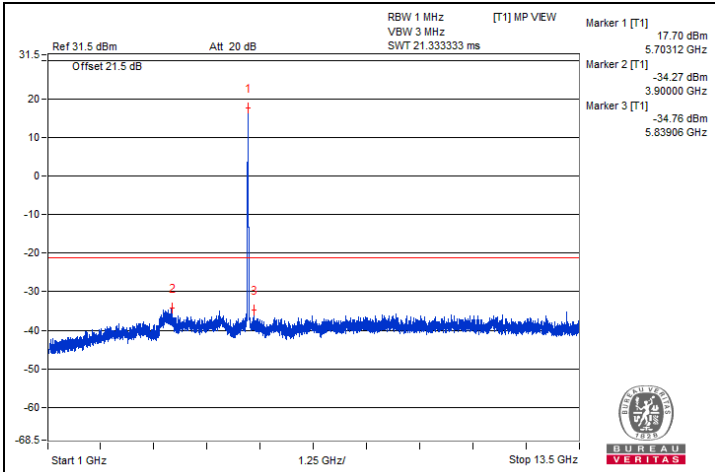

**Bandedge table**

No.	Frequency (MHz)	Emission Level (dBUV/m)	Limit (dBUV/m)	Margin (dB)	Raw Value (dBm)	Correction Factor (dB)	EIRP Level (dBm)
1	#5730.75	67.92 PK	68.2	-0.28	-32.26	4.92	-27.34

Remarks:

1. Margin value = Emission Level – Limit value
2. The other emission levels were very low against the limit.
3. " # " : The frequency is out of the restricted band.

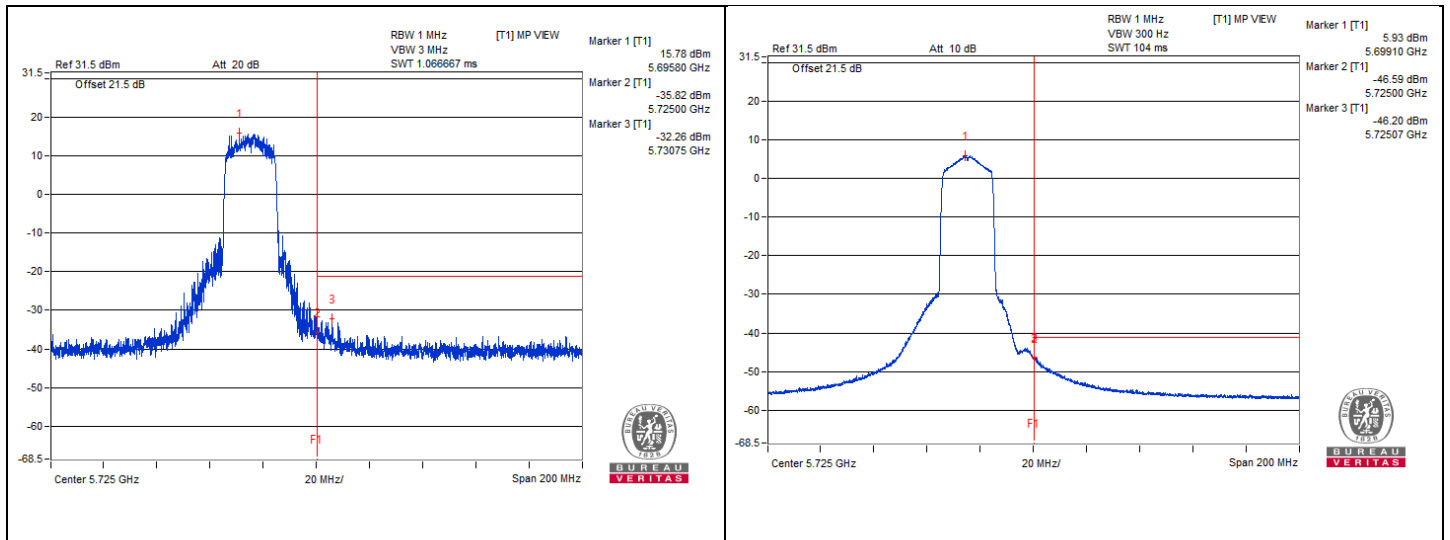

**802.11be (EHT20) - Channel 144**
**Conducted spurious emission table**

No.	Frequency (MHz)	Emission Level (dBuV/m)	Limit (dBuV/m)	Margin (dB)	Raw Value (dBm)	Correction Factor (dB)	EIRP Level (dBm)
1	3831.25	64.92 PK	74	-9.08	-35.26	4.92	-30.34
2	3820.31	43.47 AV	54	-10.53	-56.71	4.92	-51.79
3	7629.62	62.7 PK	74	-11.3	-37.48	4.92	-32.56
4	7629.68	41.07 AV	54	-12.93	-59.11	4.92	-54.19
5	11440	63.3 PK	74	-10.7	-36.88	4.92	-31.96
6	11440.62	41.6 AV	54	-12.4	-58.58	4.92	-53.66
7	#17142.62	52.53 PK	68.2	-15.67	-47.65	4.92	-42.73

**Remarks:**

1. Margin value = Emission Level – Limit value
2. The other emission levels were very low against the limit.
3. " # " : The frequency is out of the restricted band.

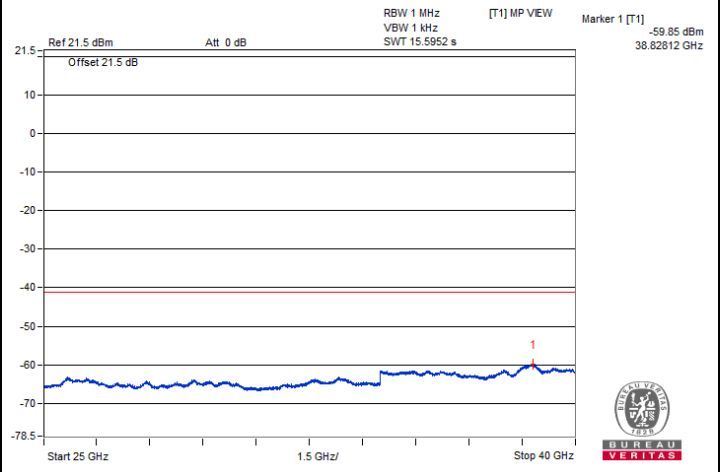
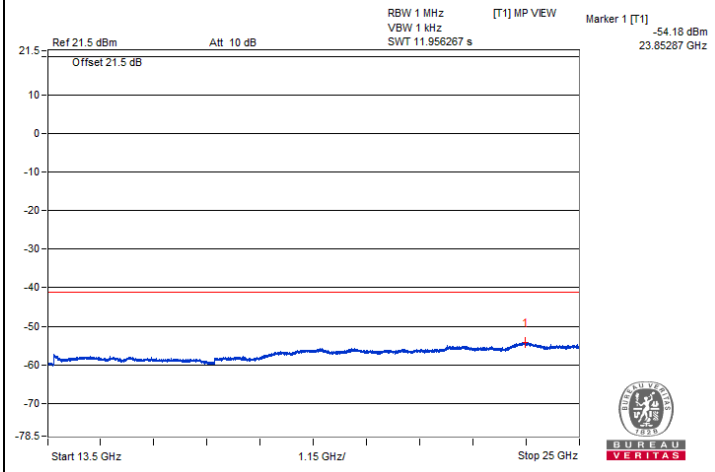
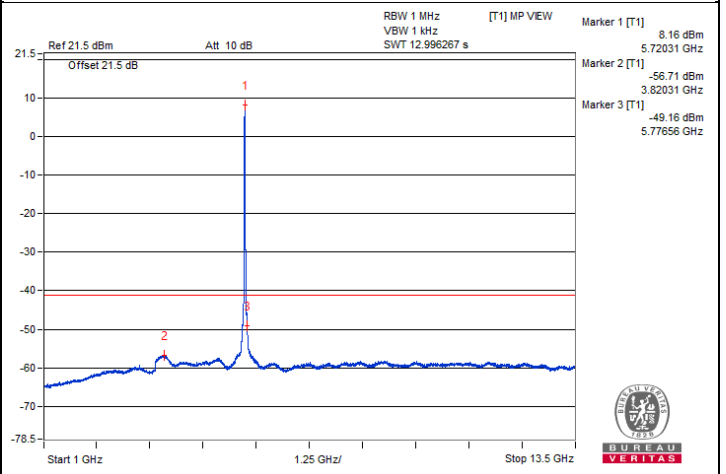
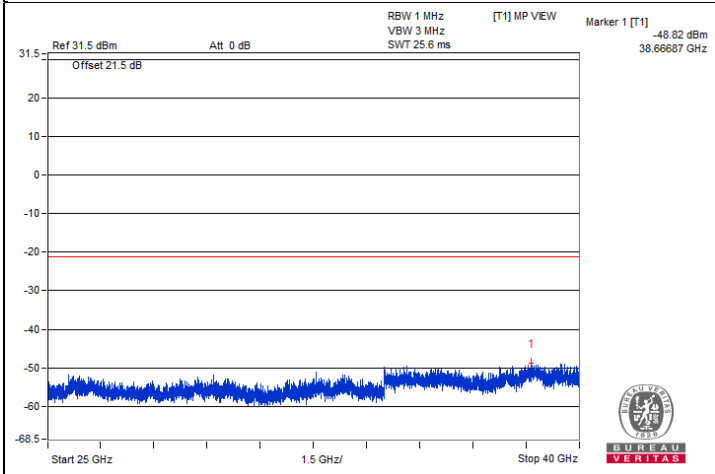
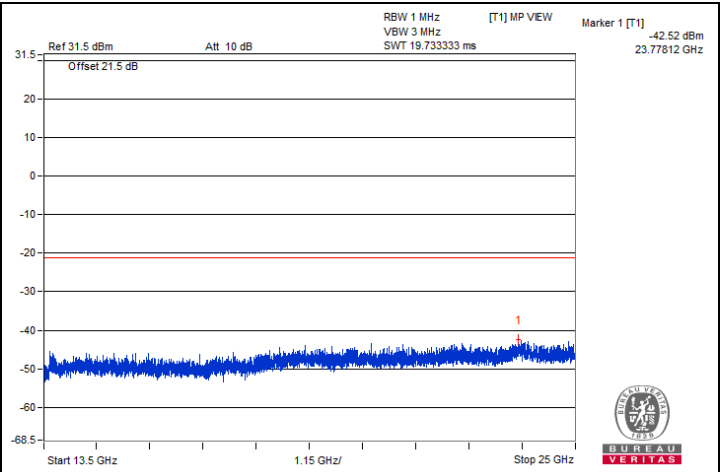
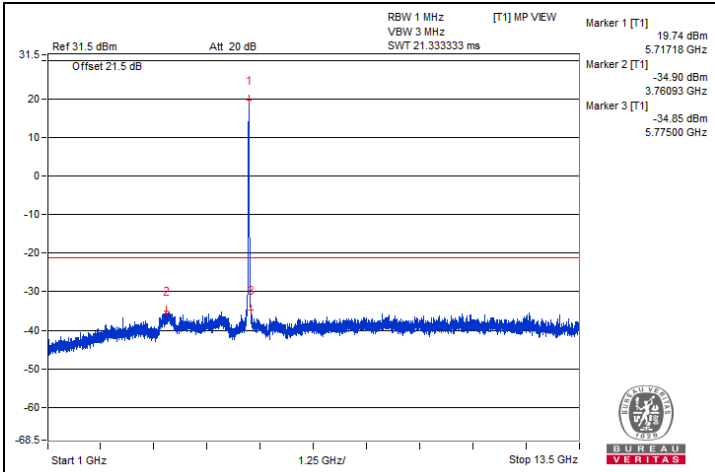

**Bandedge table**

No.	Frequency (MHz)	Emission Level (dBUV/m)	Limit (dBUV/m)	Margin (dB)	Raw Value (dBm)	Correction Factor (dB)	EIRP Level (dBm)
1	#5878.86	63.9 PK	68.2	-4.3	-36.28	4.92	-31.36

Remarks:

1. Margin value = Emission Level – Limit value
2. The other emission levels were very low against the limit.
3. " # " : The frequency is out of the restricted band.

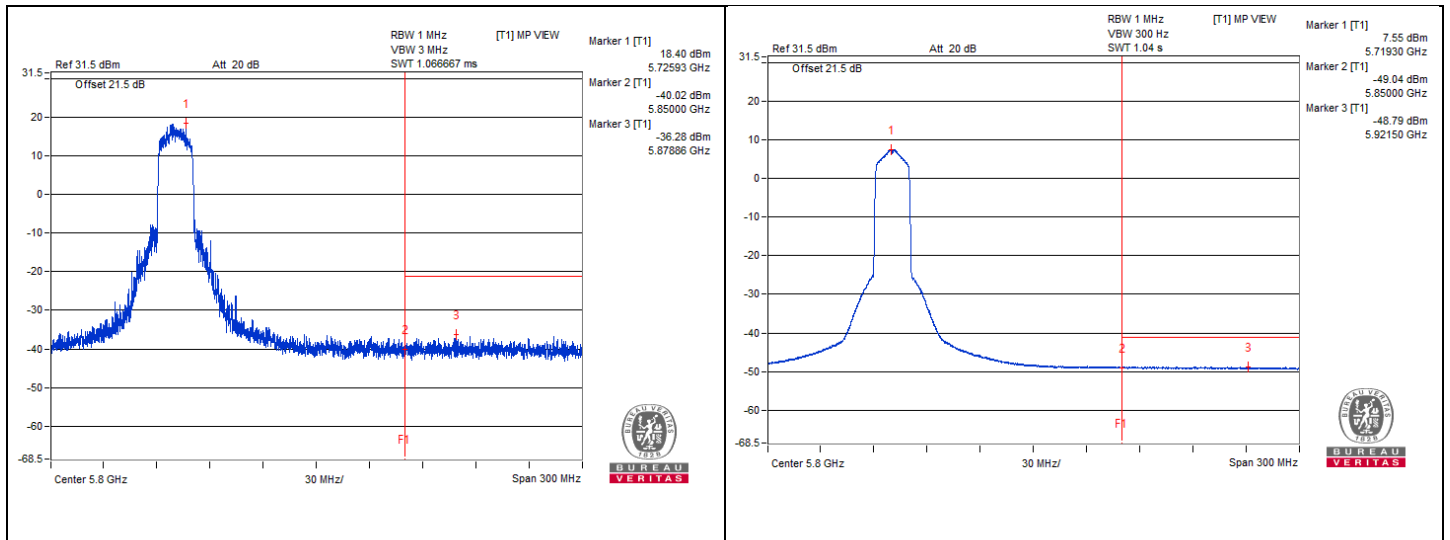

**802.11be (EHT40) - Channel 54**
**Conducted spurious emission table**

No.	Frequency (MHz)	Emission Level (dBuV/m)	Limit (dBuV/m)	Margin (dB)	Raw Value (dBm)	Correction Factor (dB)	EIRP Level (dBm)
1	3514.06	60.15 PK	74	-13.85	-40.03	4.92	-35.11
2	3521.87	39.1 AV	54	-14.9	-61.08	4.92	-56.16
3	#7012.5	62.48 PK	68.2	-5.72	-37.7	4.92	-32.78
4	#10537.5	62.24 PK	68.2	-5.96	-37.94	4.92	-33.02
5	15828.75	51.58 PK	74	-22.42	-48.6	4.92	-43.68
6	15827.25	41.67 AV	54	-12.33	-58.51	4.92	-53.59

**Remarks:**

1. Margin value = Emission Level – Limit value
2. The other emission levels were very low against the limit.
3. " # " : The frequency is out of the restricted band.

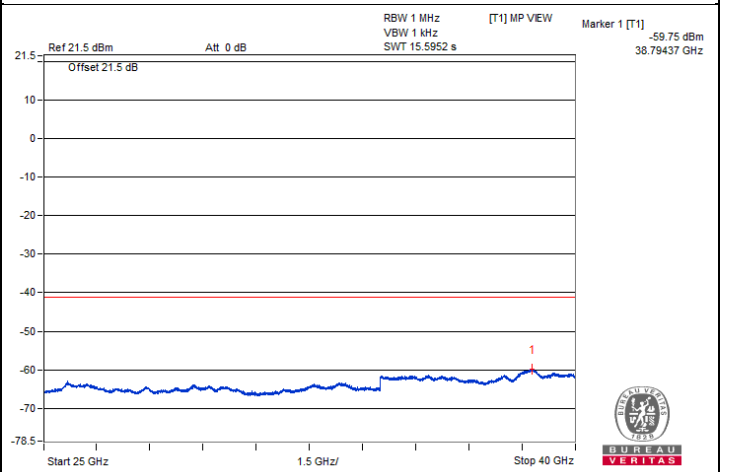
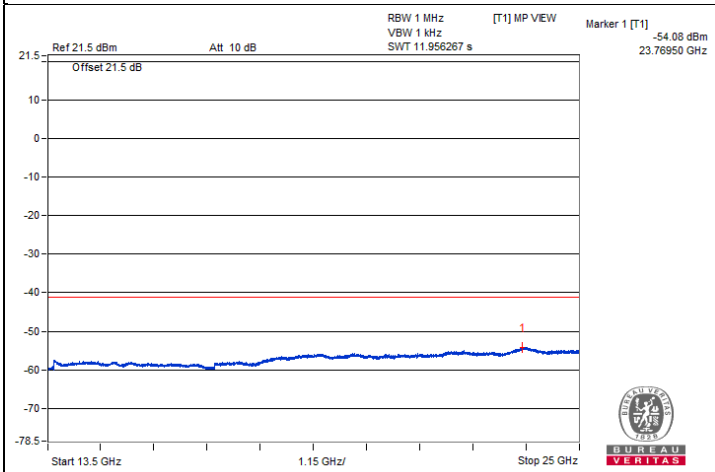
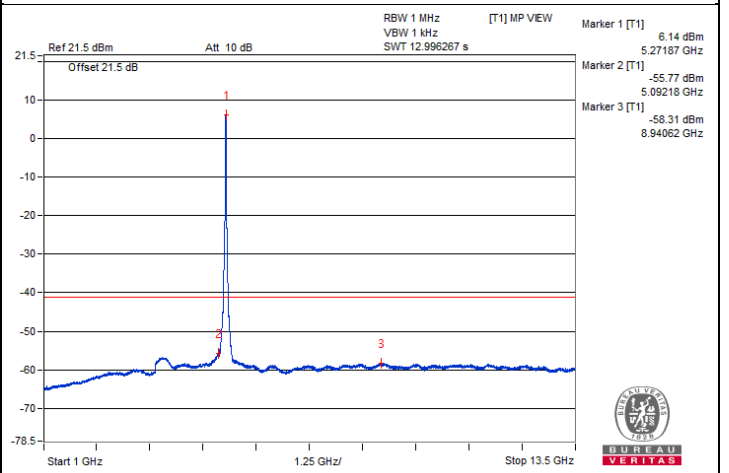
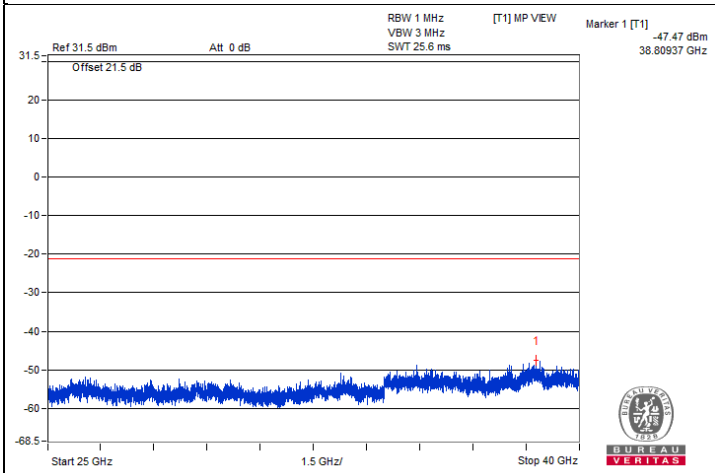
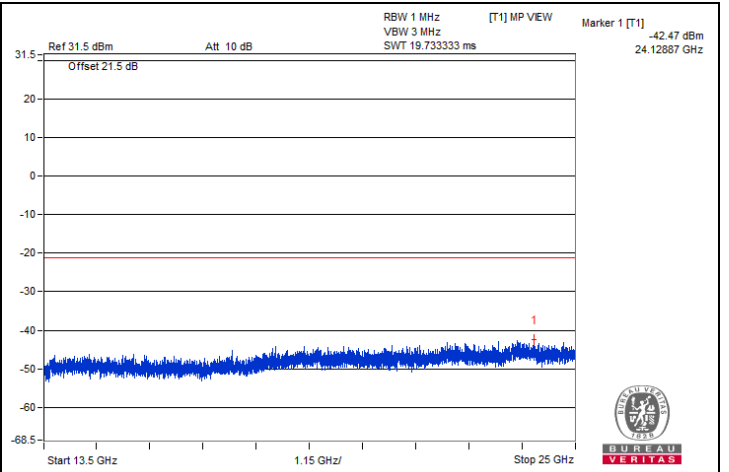
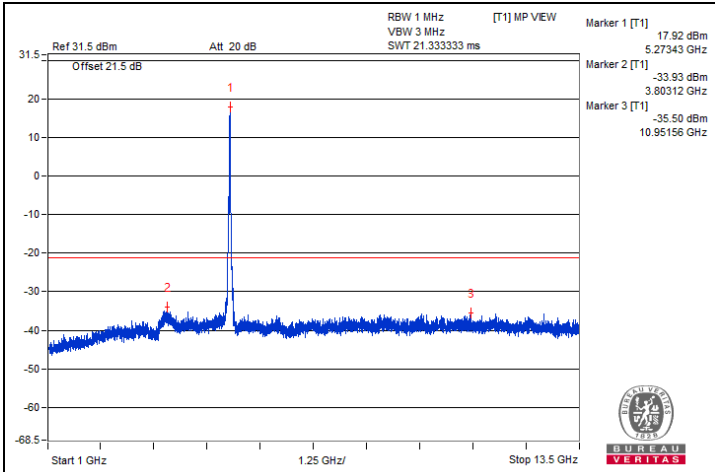



**Bandedge table**

No.	Frequency (MHz)	Emission Level (dBuV/m)	Limit (dBuV/m)	Margin (dB)	Raw Value (dBm)	Correction Factor (dB)	EIRP Level (dBm)
1	5355.1	66.49 PK	74	-7.51	-33.69	4.92	-28.77
2	5350.2	51.39 AV	54	-2.61	-48.79	4.92	-43.87

Remarks:

1. Margin value = Emission Level – Limit value
2. The other emission levels were very low against the limit.

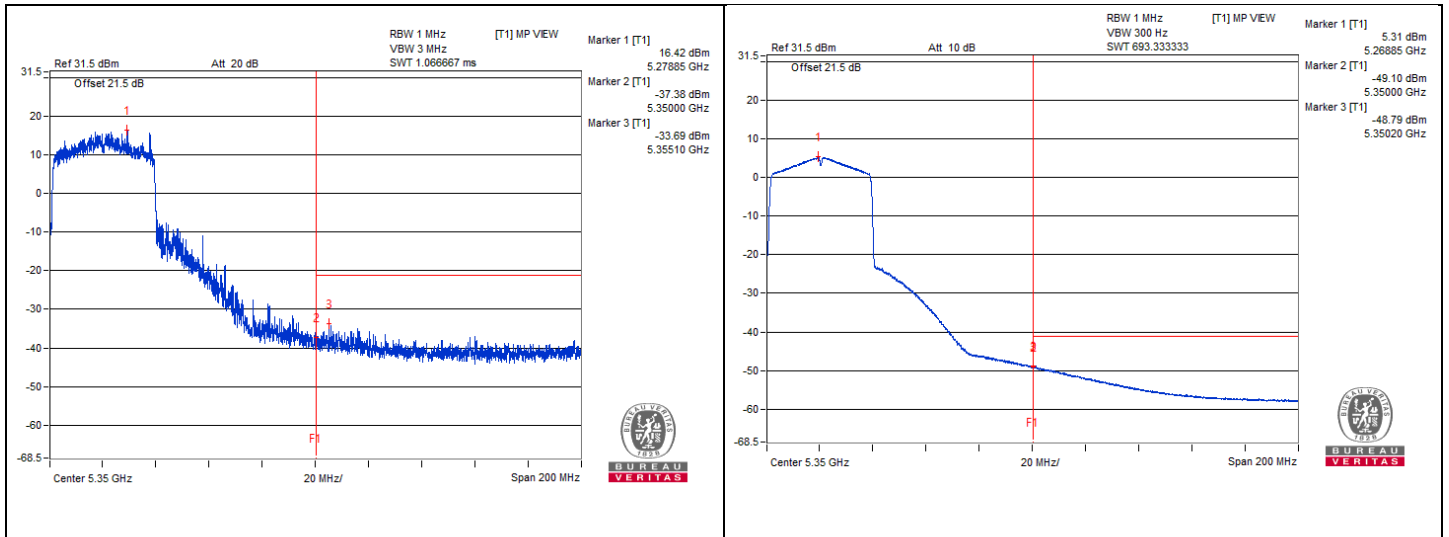

**802.11be (EHT40) - Channel 62**
**Conducted spurious emission table**

No.	Frequency (MHz)	Emission Level (dBuV/m)	Limit (dBuV/m)	Margin (dB)	Raw Value (dBm)	Correction Factor (dB)	EIRP Level (dBm)
1	3559.68	60.32 PK	74	-13.68	-39.86	4.92	-34.94
2	3559.37	39.27 AV	54	-14.73	-60.91	4.92	-55.99
3	#7092.18	62.34 PK	68.2	-5.86	-37.84	4.92	-32.92
4	10635	63.55 PK	74	-10.45	-36.63	4.92	-31.71
5	10635.93	41.4 AV	54	-12.6	-58.78	4.92	-53.86
6	15937.87	52.02 PK	74	-21.98	-48.16	4.92	-43.24
7	15940.87	41.76 AV	54	-12.24	-58.42	4.92	-53.50

Remarks:

1. Margin value = Emission Level – Limit value
2. The other emission levels were very low against the limit.
3. " # " : The frequency is out of the restricted band.



BUREAU VERITAS

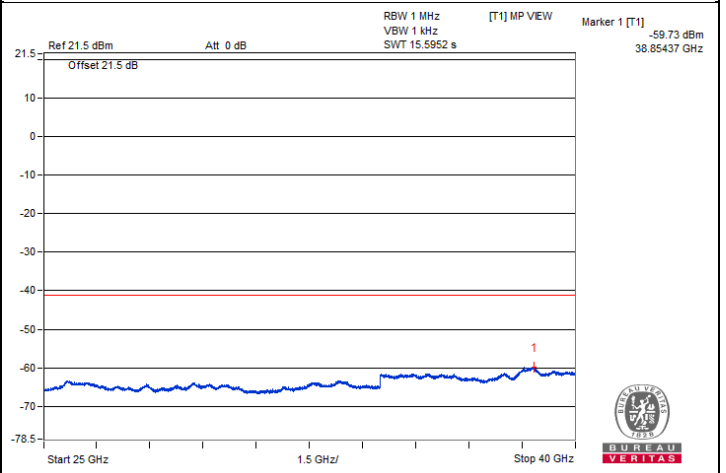
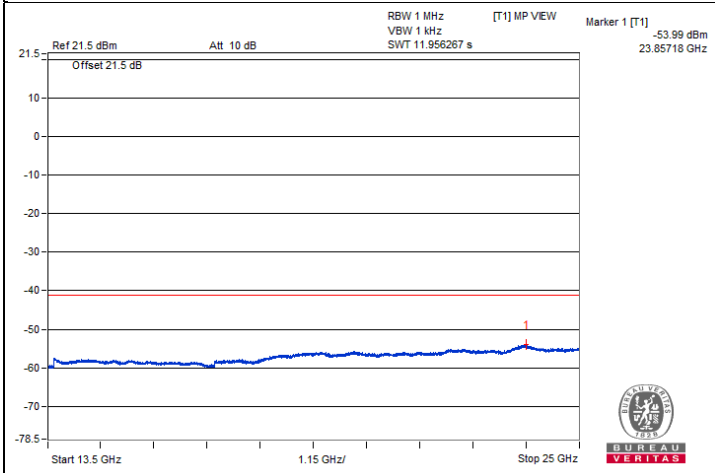
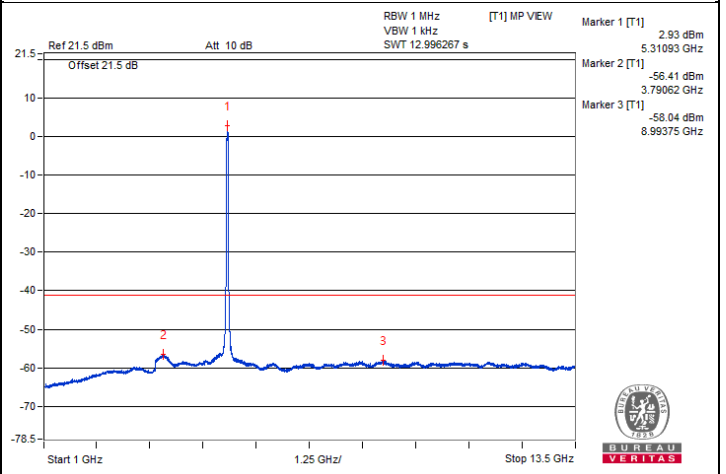
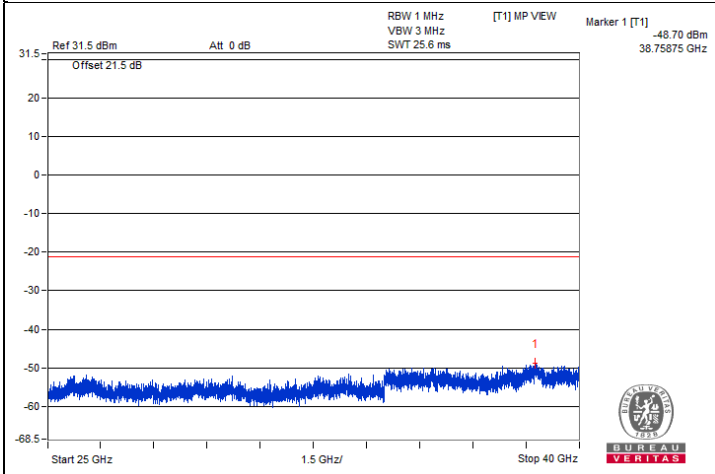
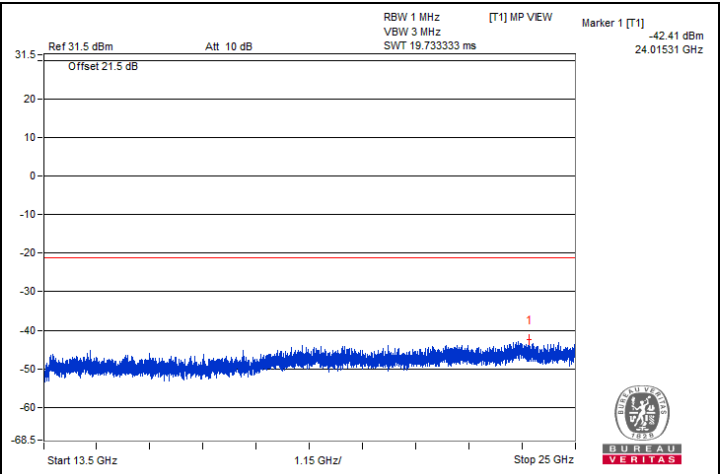
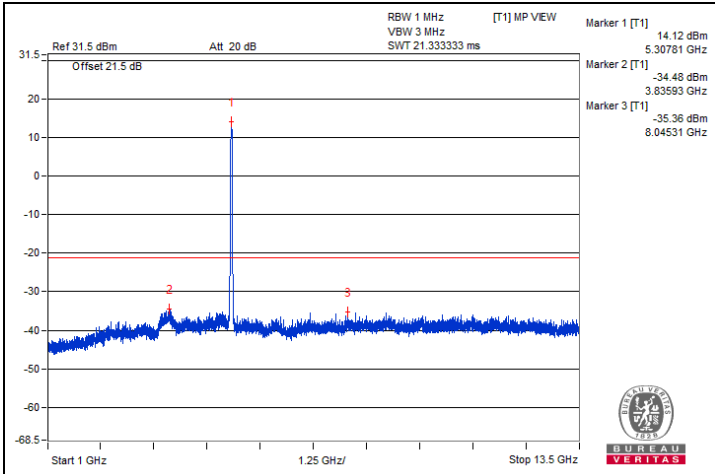

**Bandedge table**

No.	Frequency (MHz)	Emission Level (dBuV/m)	Limit (dBuV/m)	Margin (dB)	Raw Value (dBm)	Correction Factor (dB)	EIRP Level (dBm)
1	5351.1	65.66 PK	74	-8.34	-34.52	4.92	-29.60
2	5350.22	52.35 AV	54	-1.65	-47.83	4.92	-42.91

Remarks:

1. Margin value = Emission Level – Limit value
2. The other emission levels were very low against the limit.

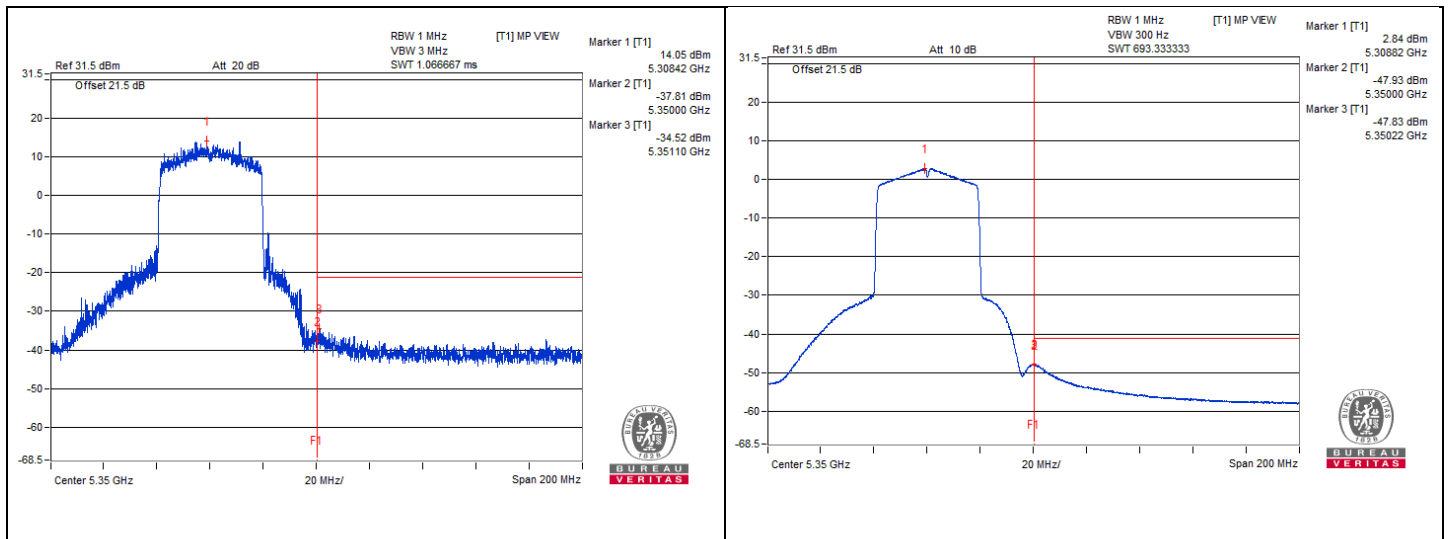

### 802.11be (EHT40) - Channel 102

#### Conducted spurious emission table

No.	Frequency (MHz)	Emission Level (dBuV/m)	Limit (dBuV/m)	Margin (dB)	Raw Value (dBm)	Correction Factor (dB)	EIRP Level (dBm)
1	3667.18	63.47 PK	74	-10.53	-36.71	4.92	-31.79
2	3670.31	42.71 AV	54	-11.29	-57.47	4.92	-52.55
3	7354.12	62.15 PK	74	-11.85	-38.03	4.92	-33.11
4	7354.68	40.84 AV	54	-13.16	-59.34	4.92	-54.42
5	11029.68	63.44 PK	74	-10.56	-36.74	4.92	-31.82
6	11029.06	41.46 AV	54	-12.54	-58.72	4.92	-53.80
7	#16530.25	52.89 PK	68.2	-15.31	-47.29	4.92	-42.37

Remarks:

1. Margin value = Emission Level – Limit value
2. The other emission levels were very low against the limit.
3. " # " : The frequency is out of the restricted band.

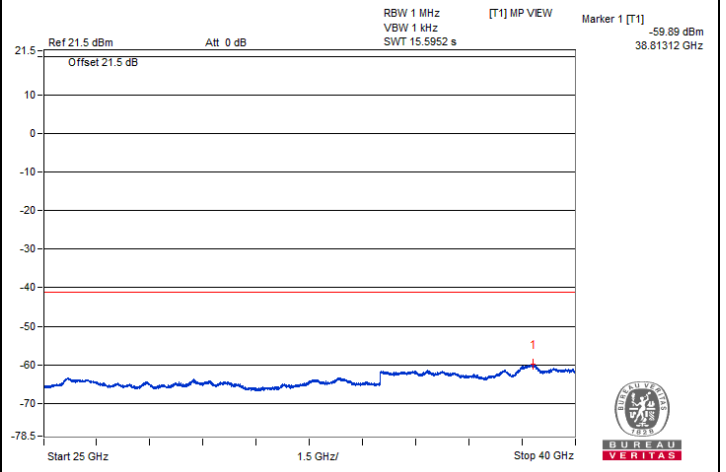
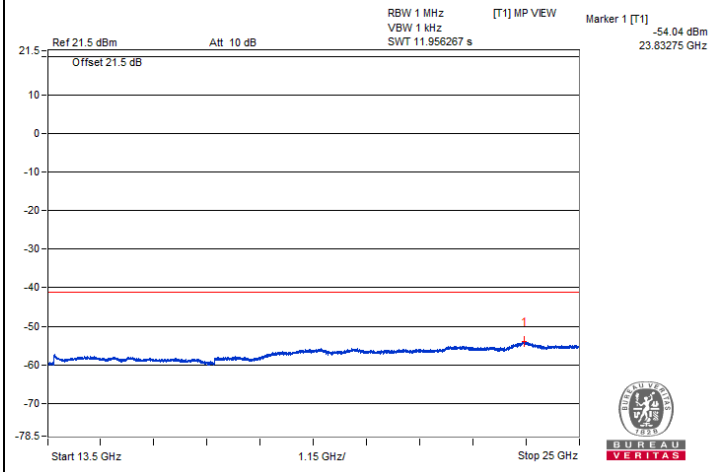
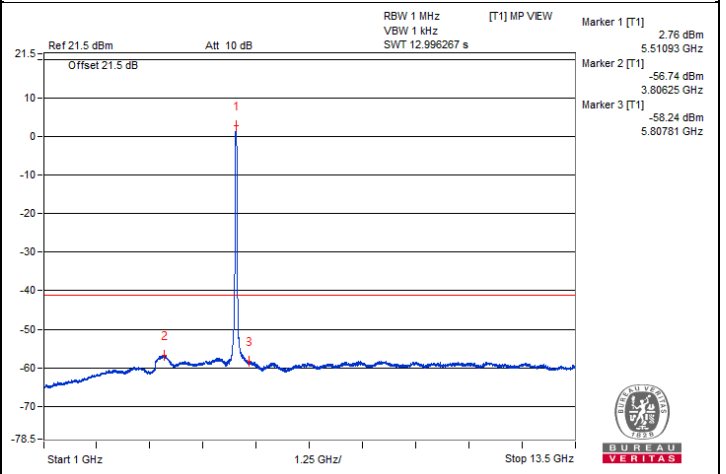
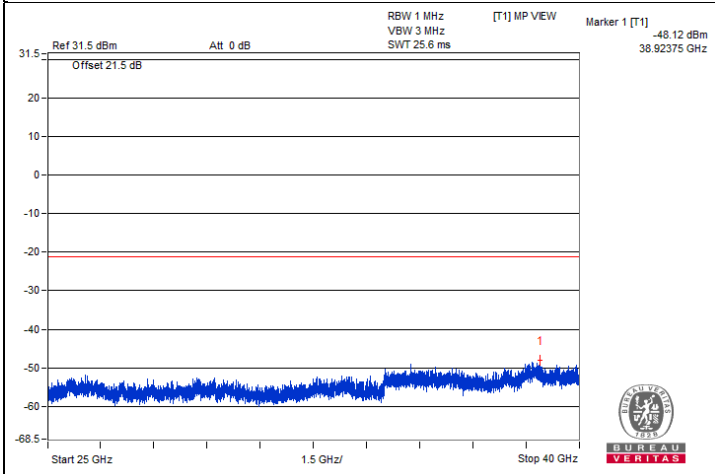
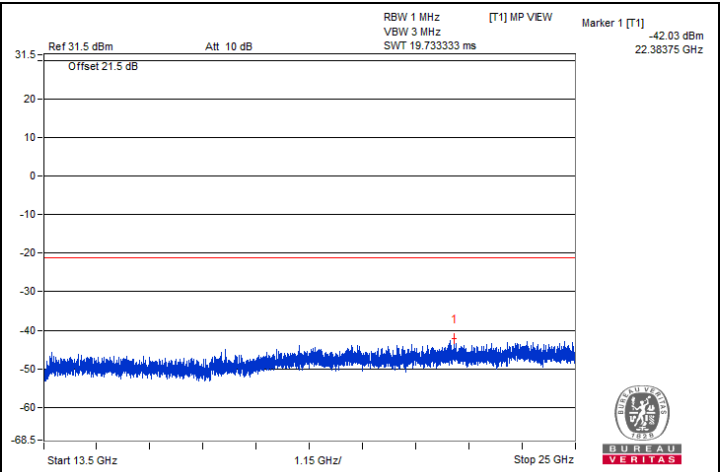
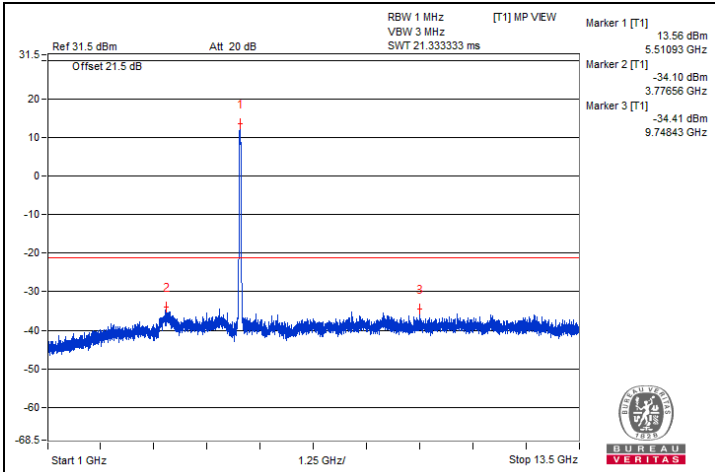

**Bandedge table**

No.	Frequency (MHz)	Emission Level (dBuV/m)	Limit (dBuV/m)	Margin (dB)	Raw Value (dBm)	Correction Factor (dB)	EIRP Level (dBm)
1	5459.87	64.59 PK	74	-9.41	-35.59	4.92	-30.67
2	5459.87	52.97 AV	54	-1.03	-47.21	4.92	-42.29
3	#5470	66.77 PK	68.2	-1.43	-33.41	4.92	-28.49

Remarks:

1. Margin value = Emission Level – Limit value
2. The other emission levels were very low against the limit.
3. " # " : The frequency is out of the restricted band.

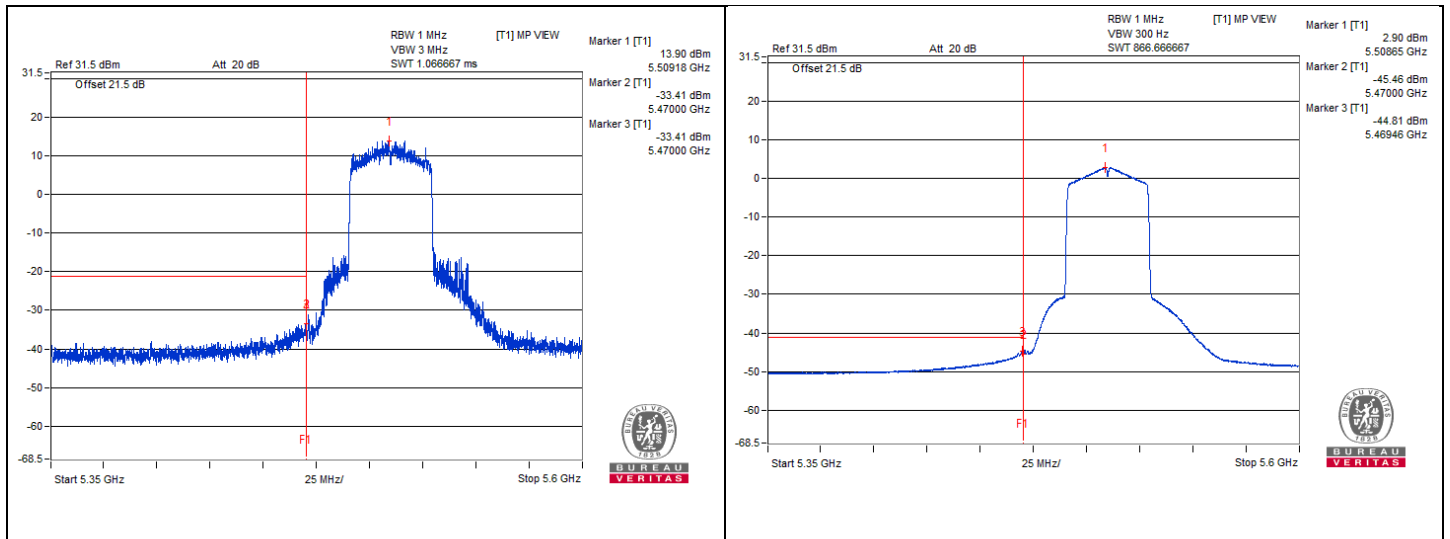

### 802.11be (EHT40) - Channel 110

#### Conducted spurious emission table

No.	Frequency (MHz)	Emission Level (dBuV/m)	Limit (dBuV/m)	Margin (dB)	Raw Value (dBm)	Correction Factor (dB)	EIRP Level (dBm)
1	3701.5	64.99 PK	74	-9.01	-35.19	4.92	-30.27
2	3701.56	42.87 AV	54	-11.13	-57.31	4.92	-52.39
3	7404.68	62.25 PK	74	-11.75	-37.93	4.92	-33.01
4	7403.12	40.52 AV	54	-13.48	-59.66	4.92	-54.74
5	11109.37	63.01 PK	74	-10.99	-37.17	4.92	-32.25
6	11108.43	41.44 AV	54	-12.56	-58.74	4.92	-53.82
7	#16638.06	50.84 PK	68.2	-17.36	-49.34	4.92	-44.42

#### Remarks:

1. Margin value = Emission Level – Limit value
2. The other emission levels were very low against the limit.
3. " # " : The frequency is out of the restricted band.



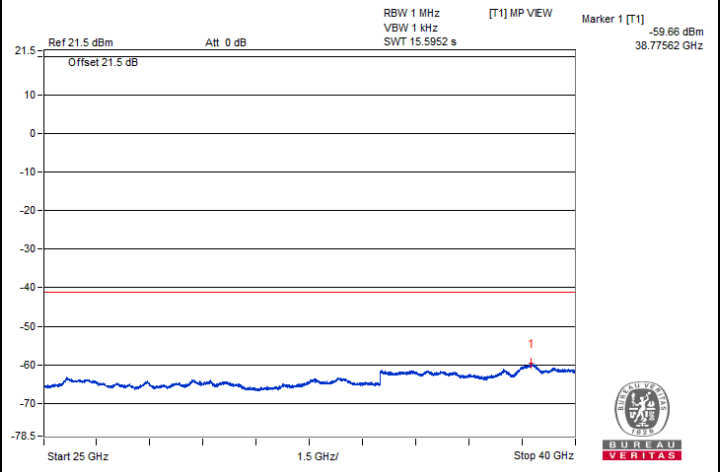
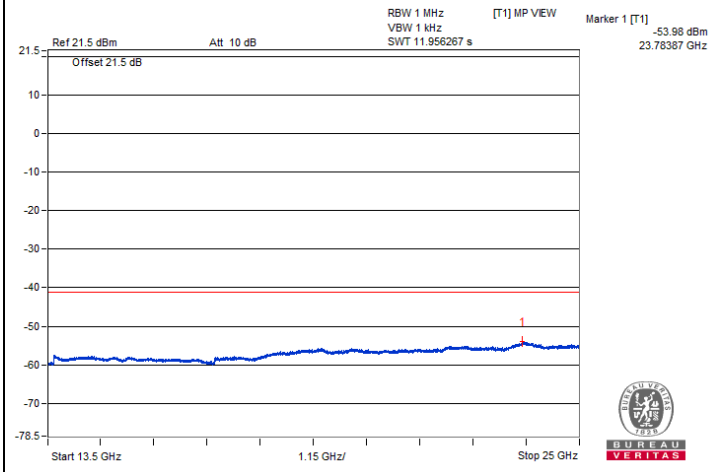
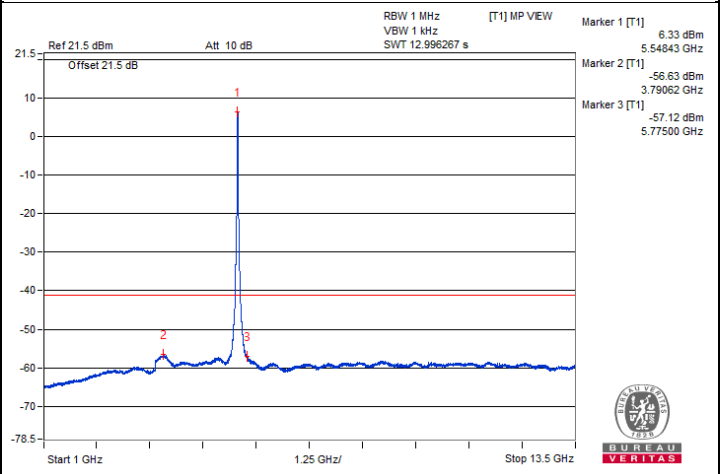
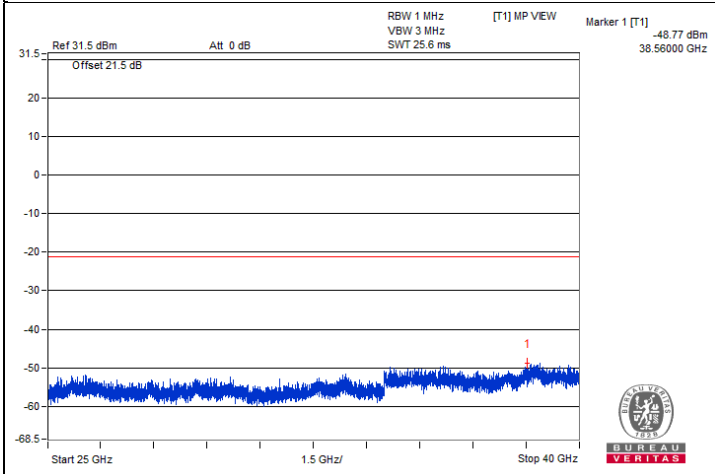
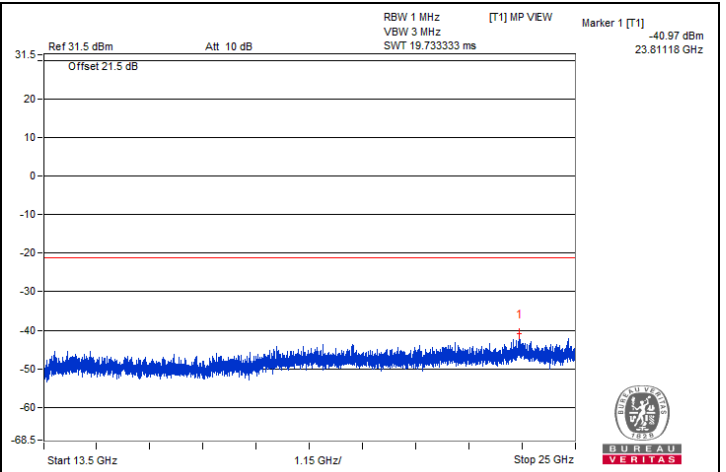
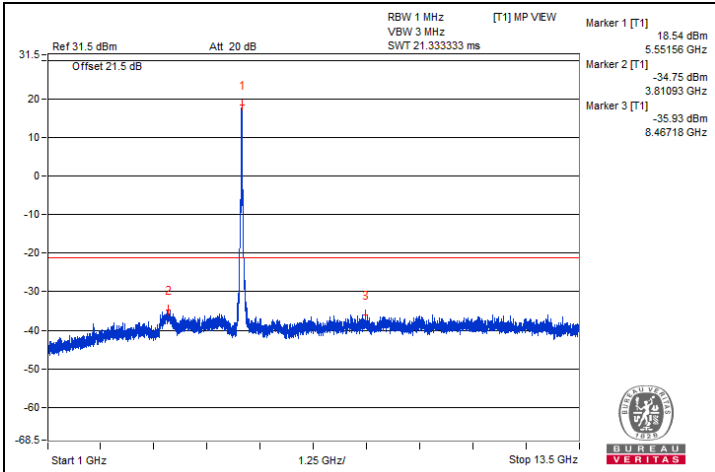

**Bandedge table**

No.	Frequency (MHz)	Emission Level (dBuV/m)	Limit (dBuV/m)	Margin (dB)	Raw Value (dBm)	Correction Factor (dB)	EIRP Level (dBm)
1	5450.65	64.23 PK	74	-9.77	-35.95	4.92	-31.03
2	5459.56	49.72 AV	54	-4.28	-50.46	4.92	-45.54
3	#5467.96	67.8 PK	68.2	-0.4	-32.38	4.92	-27.46

Remarks:

1. Margin value = Emission Level – Limit value
2. The other emission levels were very low against the limit.
3. " # " : The frequency is out of the restricted band.

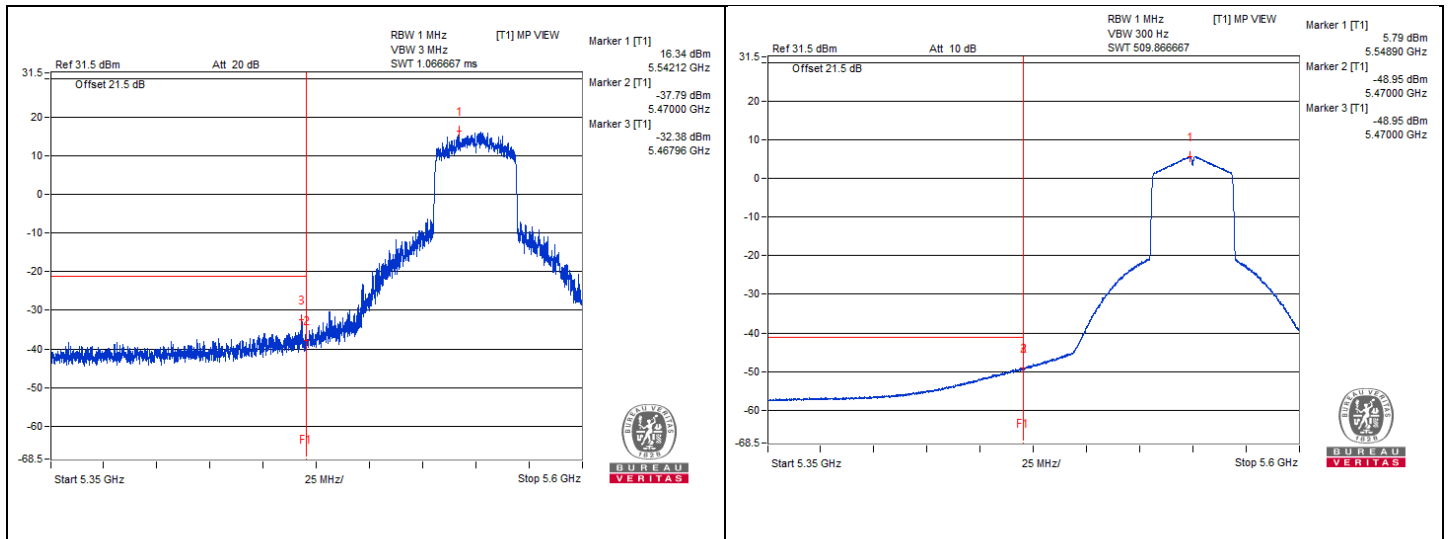

**802.11be (EHT40) - Channel 134**
**Conducted spurious emission table**

No.	Frequency (MHz)	Emission Level (dBuV/m)	Limit (dBuV/m)	Margin (dB)	Raw Value (dBm)	Correction Factor (dB)	EIRP Level (dBm)
1	3798.81	65.21 PK	74	-8.79	-34.97	4.92	-30.05
2	3798.43	43.35 AV	54	-10.65	-56.83	4.92	-51.91
3	7579.75	63.17 PK	74	-10.83	-37.01	4.92	-32.09
4	7579.68	40.79 AV	54	-13.21	-59.39	4.92	-54.47
5	11343.75	62.81 PK	74	-11.19	-37.37	4.92	-32.45
6	11343.12	40.93 AV	54	-13.07	-59.25	4.92	-54.33
7	#17020.43	51.75 PK	68.2	-16.45	-48.43	4.92	-43.51

**Remarks:**

1. Margin value = Emission Level – Limit value
2. The other emission levels were very low against the limit.
3. " # " : The frequency is out of the restricted band.

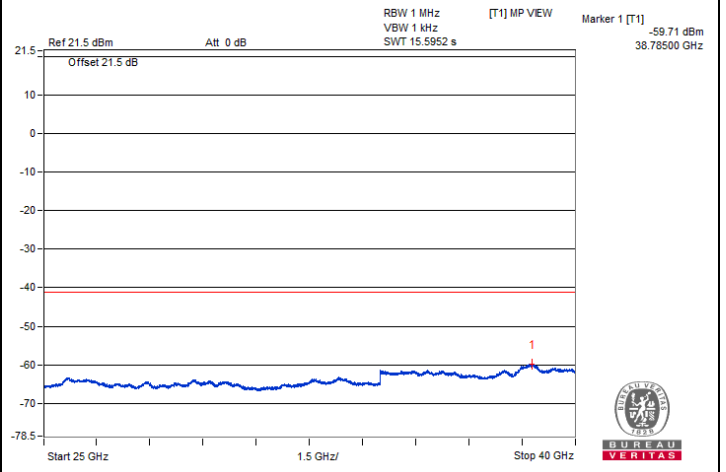
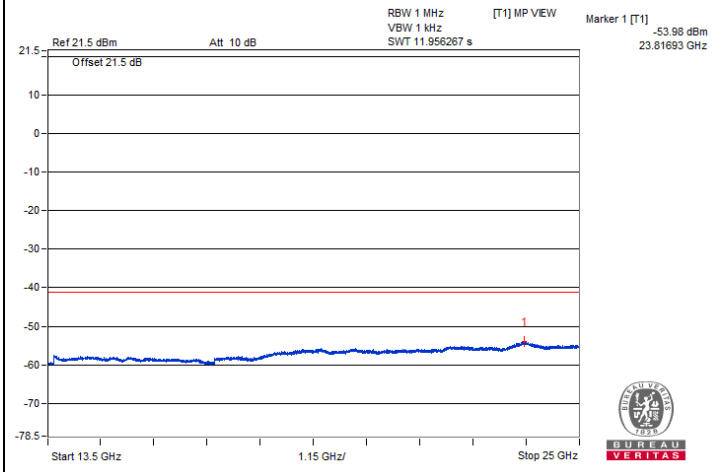
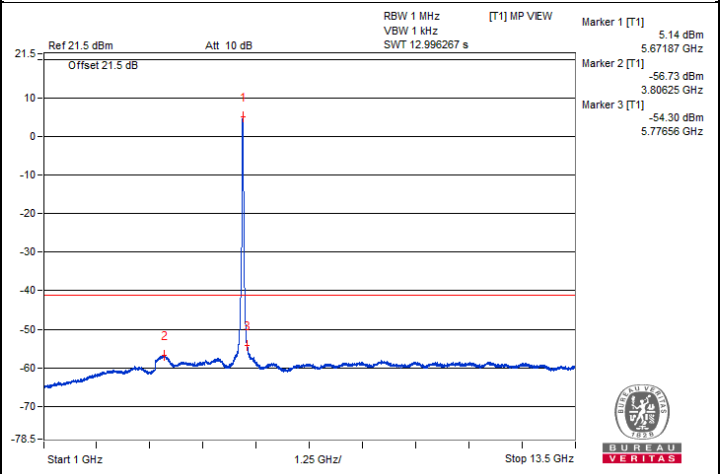
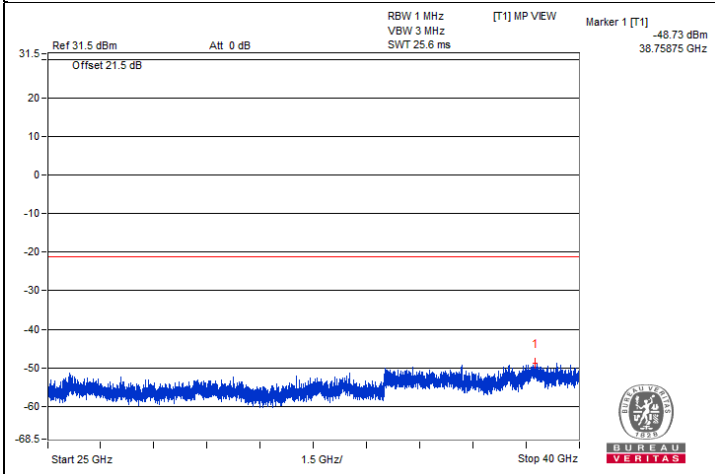
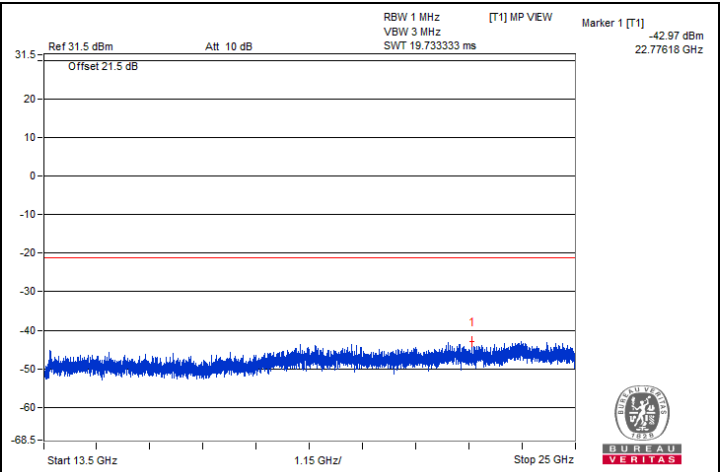
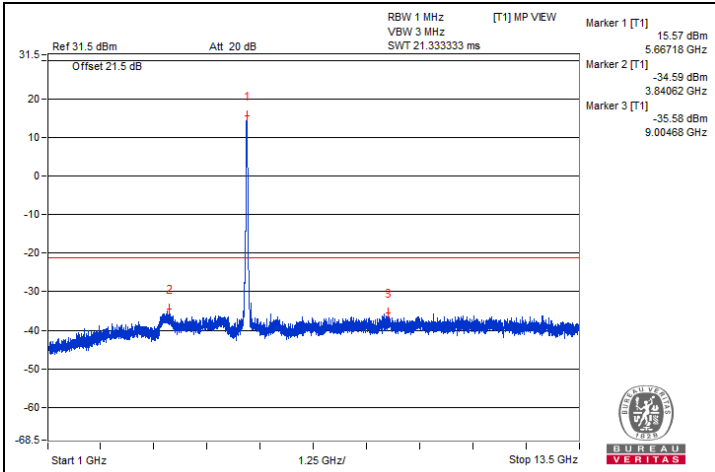

**Bandedge table**

No.	Frequency (MHz)	Emission Level (dBuV/m)	Limit (dBuV/m)	Margin (dB)	Raw Value (dBm)	Correction Factor (dB)	EIRP Level (dBm)
1	#5725.32	67.28 PK	68.2	-0.92	-32.9	4.92	-27.98

Remarks:

1. Margin value = Emission Level – Limit value
2. The other emission levels were very low against the limit.
3. " # " : The frequency is out of the restricted band.

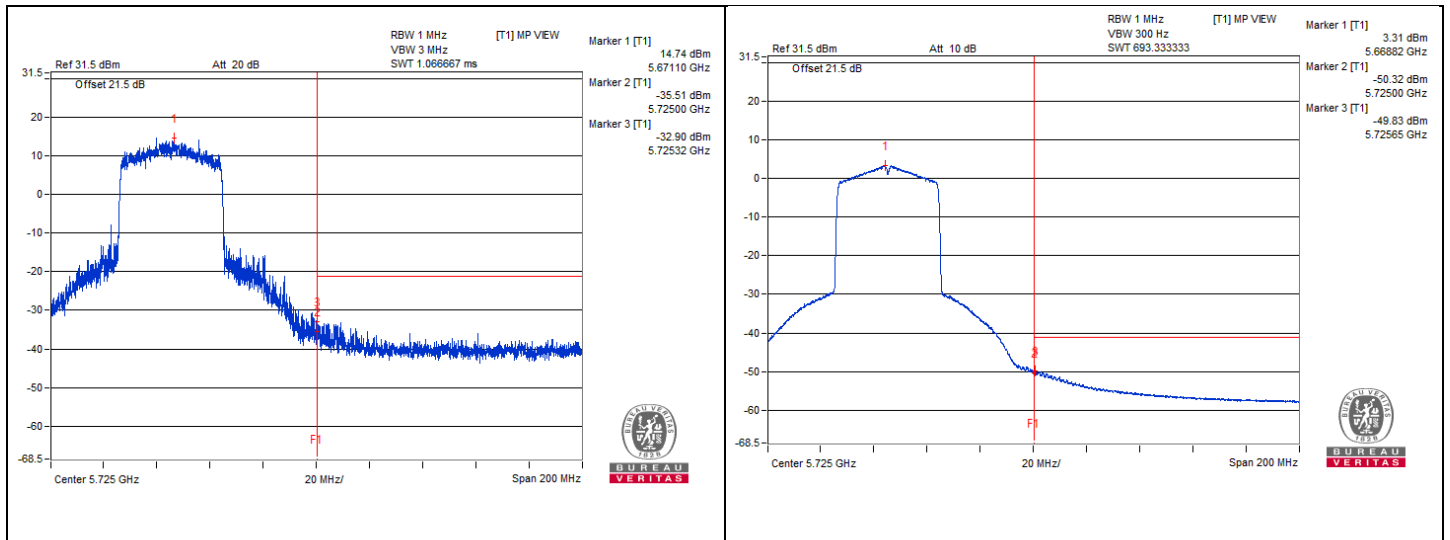

## 802.11be (EHT40) - Channel 142

### Conducted spurious emission table

No.	Frequency (MHz)	Emission Level (dBuV/m)	Limit (dBuV/m)	Margin (dB)	Raw Value (dBm)	Correction Factor (dB)	EIRP Level (dBm)
1	3803.12	66.04 PK	74	-7.96	-34.14	4.92	-29.22
2	3802.18	43.48 AV	54	-10.52	-56.7	4.92	-51.78
3	7620.31	62.99 PK	74	-11.01	-37.19	4.92	-32.27
4	7615.62	40.94 AV	54	-13.06	-59.24	4.92	-54.32
5	11428.12	63.68 PK	74	-10.32	-36.5	4.92	-31.58
6	11415.62	41.39 AV	54	-12.61	-58.79	4.92	-53.87
7	#17134	52.66 PK	68.2	-15.54	-47.52	4.92	-42.60

#### Remarks:

1. Margin value = Emission Level – Limit value
2. The other emission levels were very low against the limit.
3. " # " : The frequency is out of the restricted band.

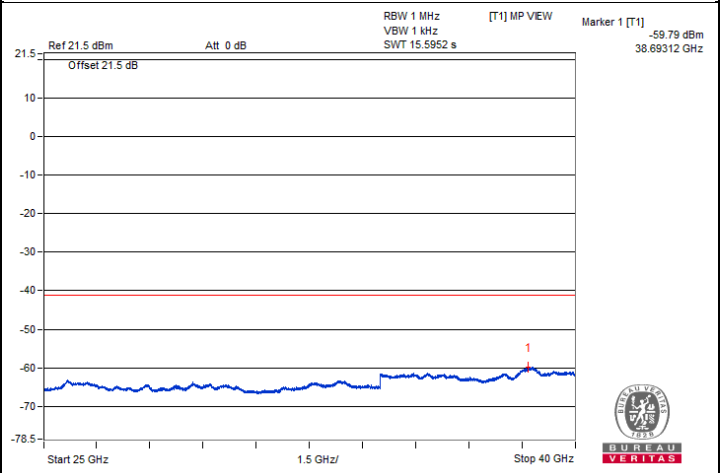
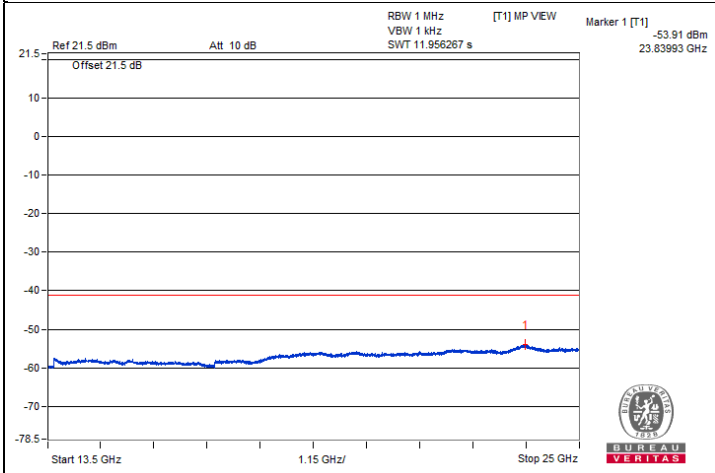
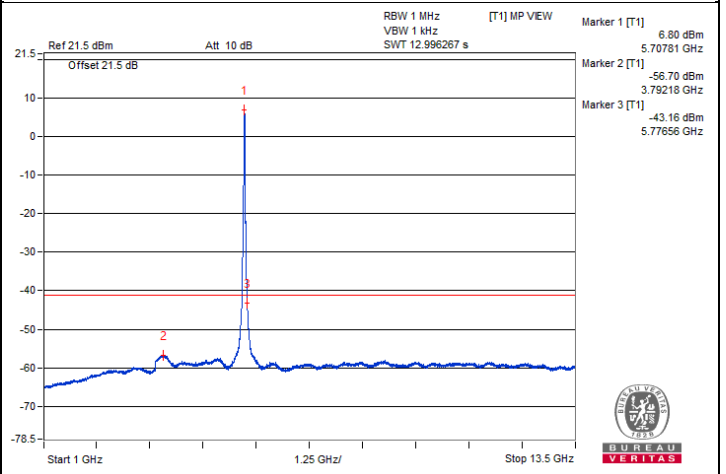
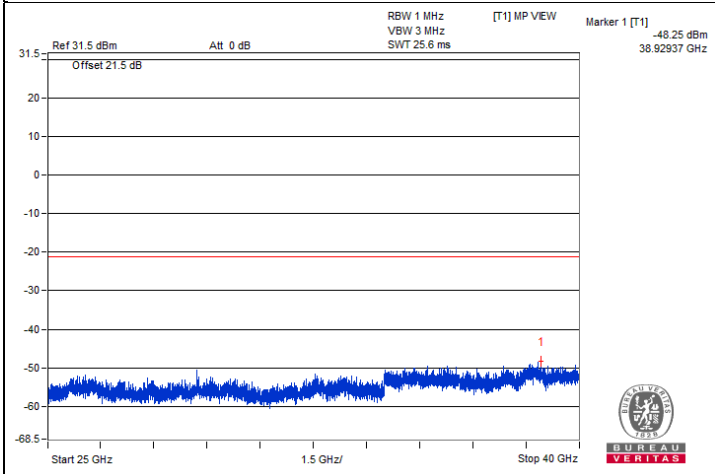
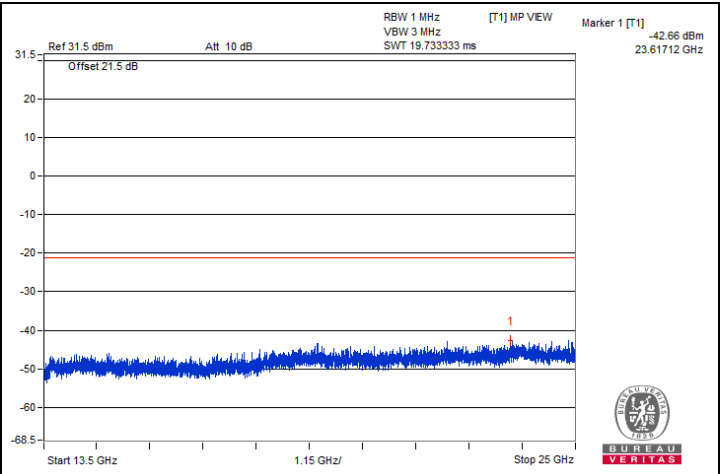
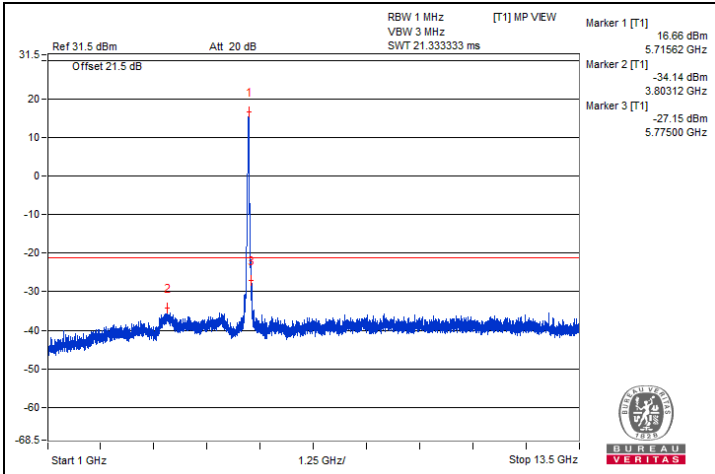

**Bandedge table**

No.	Frequency (MHz)	Emission Level (dBUV/m)	Limit (dBUV/m)	Margin (dB)	Raw Value (dBm)	Correction Factor (dB)	EIRP Level (dBm)
1	#5850.21	64.18 PK	68.2	-4.02	-36	4.92	-31.08

Remarks:

1. Margin value = Emission Level – Limit value
2. The other emission levels were very low against the limit.
3. " # " : The frequency is out of the restricted band.

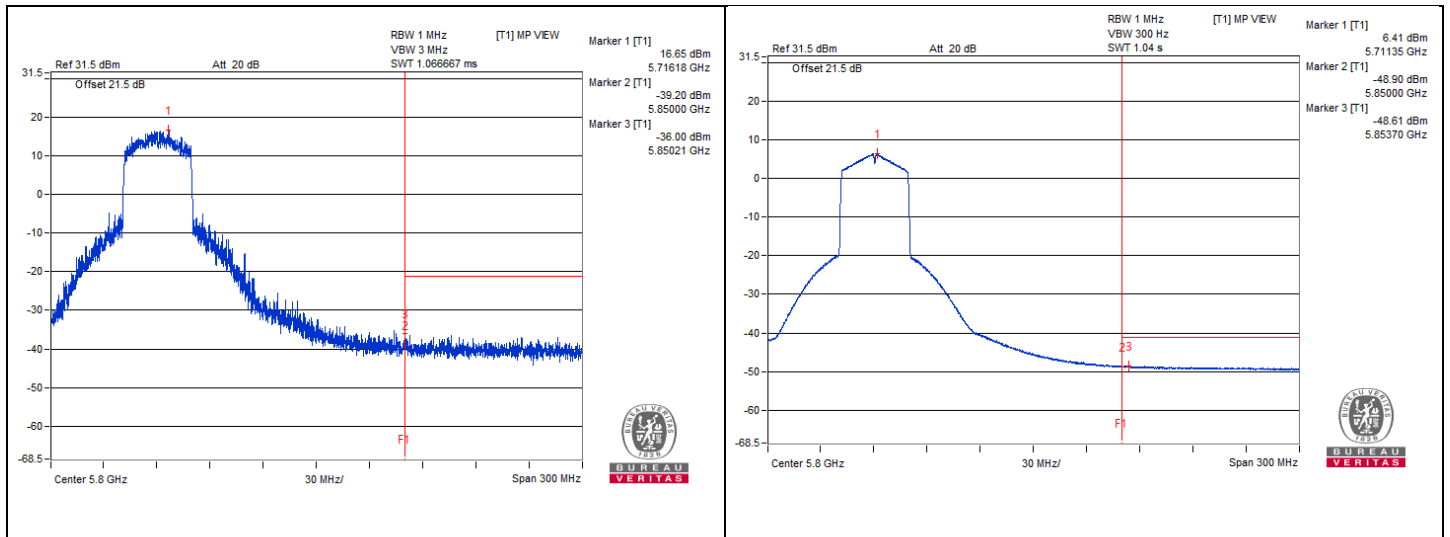



**802.11be (EHT80) - Channel 58**
**Conducted spurious emission table**

No.	Frequency (MHz)	Emission Level (dBuV/m)	Limit (dBuV/m)	Margin (dB)	Raw Value (dBm)	Correction Factor (dB)	EIRP Level (dBm)
1	3545.31	60.98 PK	74	-13.02	-39.2	4.92	-34.28
2	3540.62	39.53 AV	54	-14.47	-60.65	4.92	-55.73
3	#7037.5	62.44 PK	68.2	-5.76	-37.74	4.92	-32.82
4	#10584.37	62.72 PK	68.2	-5.48	-37.46	4.92	-32.54
5	15860.37	52.36 PK	74	-21.64	-47.82	4.92	-42.90
6	15856.06	41.61 AV	54	-12.39	-58.57	4.92	-53.65

**Remarks:**

1. Margin value = Emission Level – Limit value
2. The other emission levels were very low against the limit.
3. " # " : The frequency is out of the restricted band.



BUREAU VERITAS

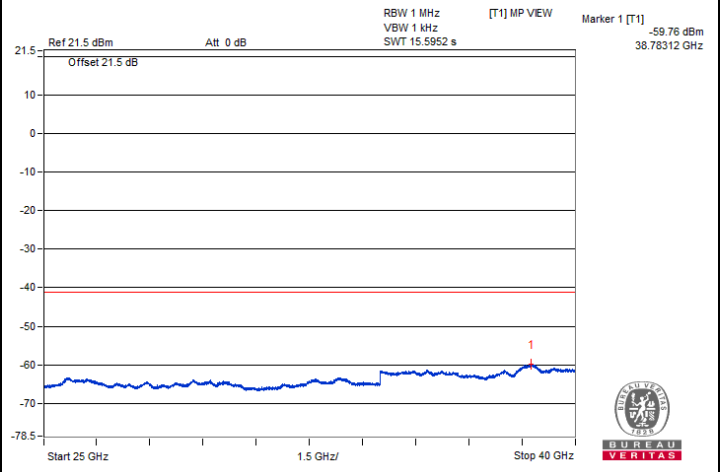
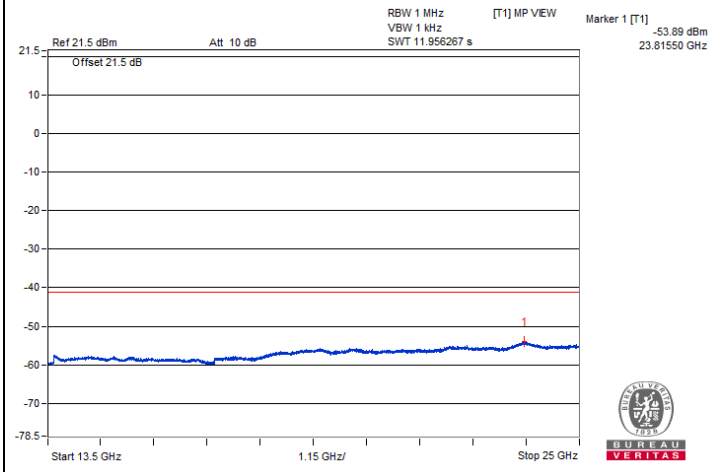
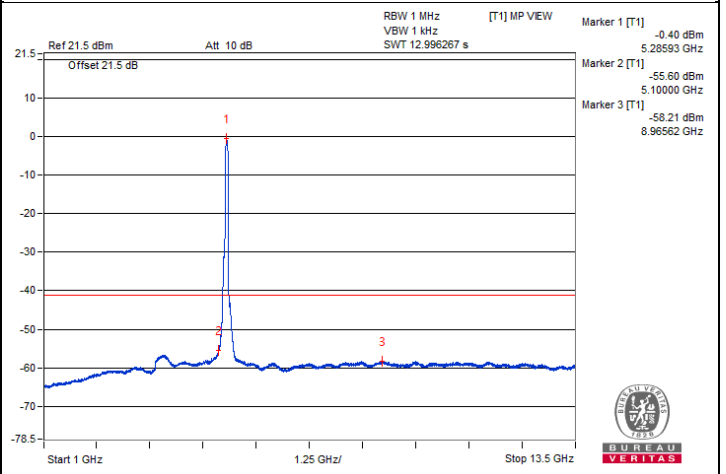
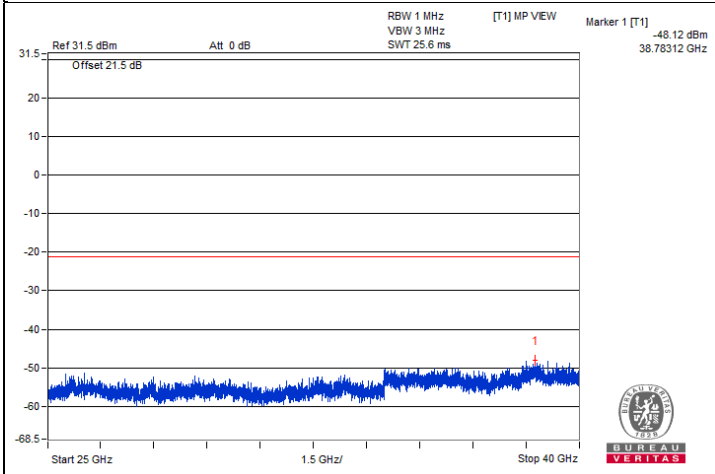
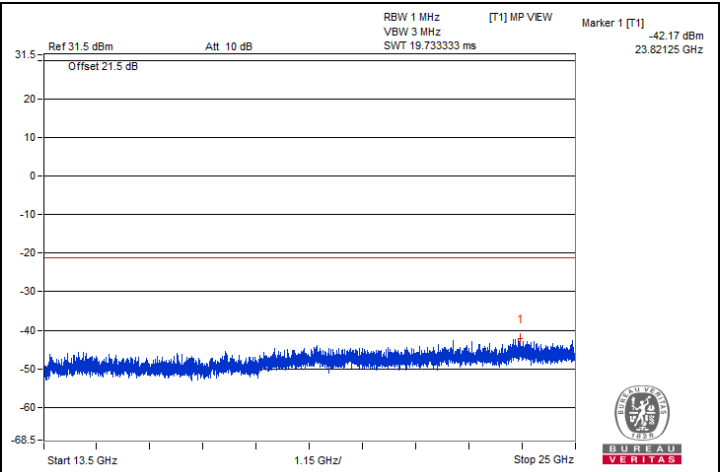
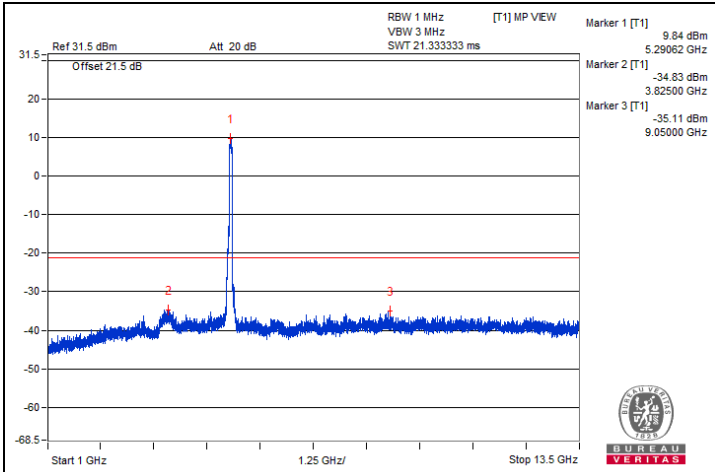

**Bandedge table**

No.	Frequency (MHz)	Emission Level (dBuV/m)	Limit (dBuV/m)	Margin (dB)	Raw Value (dBm)	Correction Factor (dB)	EIRP Level (dBm)
1	5359.8	66.3 PK	74	-7.7	-33.88	4.92	-28.96
2	5350.52	52.59 AV	54	-1.41	-47.59	4.92	-42.67

Remarks:

1. Margin value = Emission Level – Limit value
2. The other emission levels were very low against the limit.

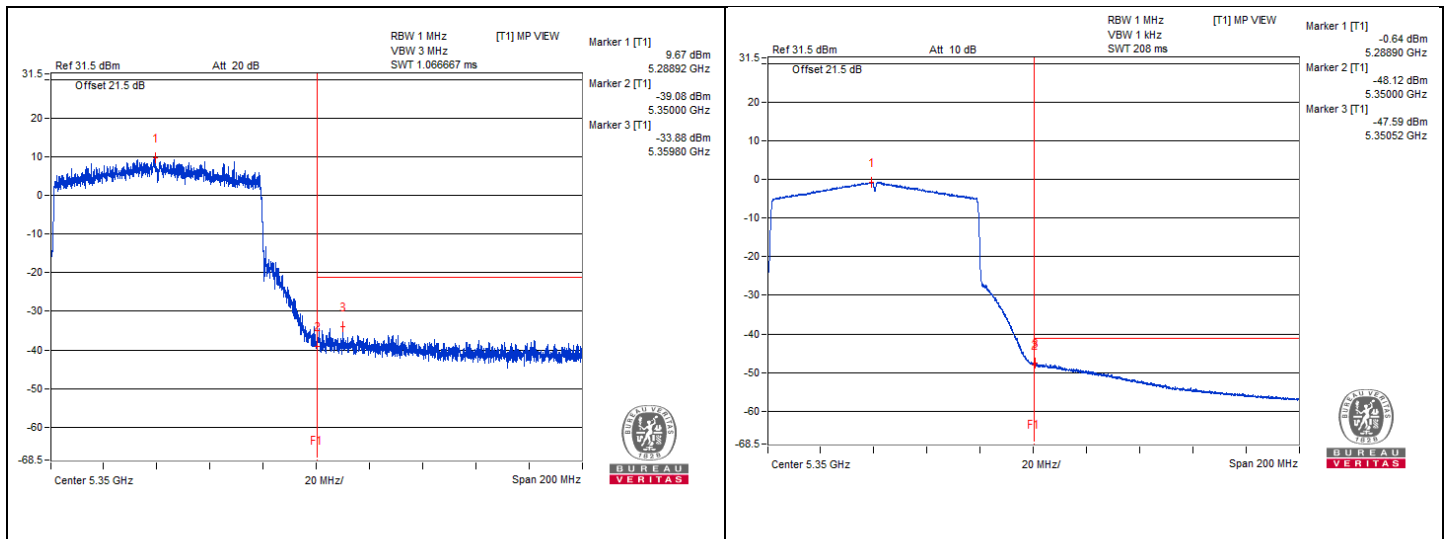

## 802.11be (EHT80) - Channel 106

### Conducted spurious emission table

No.	Frequency (MHz)	Emission Level (dBuV/m)	Limit (dBuV/m)	Margin (dB)	Raw Value (dBm)	Correction Factor (dB)	EIRP Level (dBm)
1	3696.87	63.78 PK	74	-10.22	-36.4	4.92	-31.48
2	3698.43	42.9 AV	54	-11.1	-57.28	4.92	-52.36
3	7386.56	62.04 PK	74	-11.96	-38.14	4.92	-33.22
4	7385.93	40.73 AV	54	-13.27	-59.45	4.92	-54.53
5	11054.68	63.13 PK	74	-10.87	-37.05	4.92	-32.13
6	11052.18	41.54 AV	54	-12.46	-58.64	4.92	-53.72
7	#16605	52.37 PK	68.2	-15.83	-47.81	4.92	-42.89

Remarks:

1. Margin value = Emission Level – Limit value
2. The other emission levels were very low against the limit.
3. " # " : The frequency is out of the restricted band.



BUREAU VERITAS

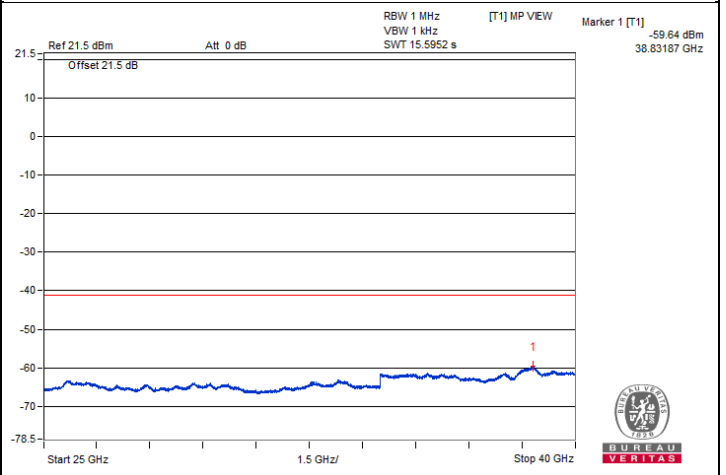
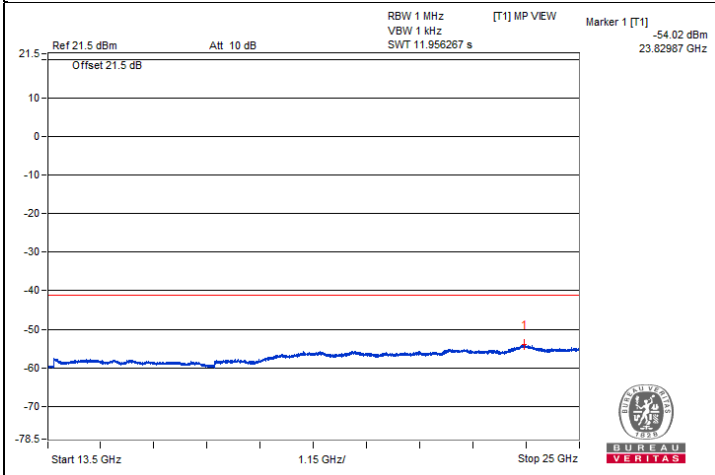
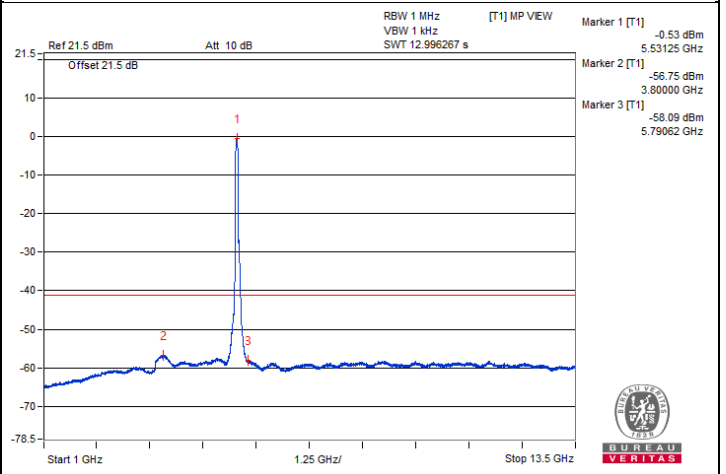
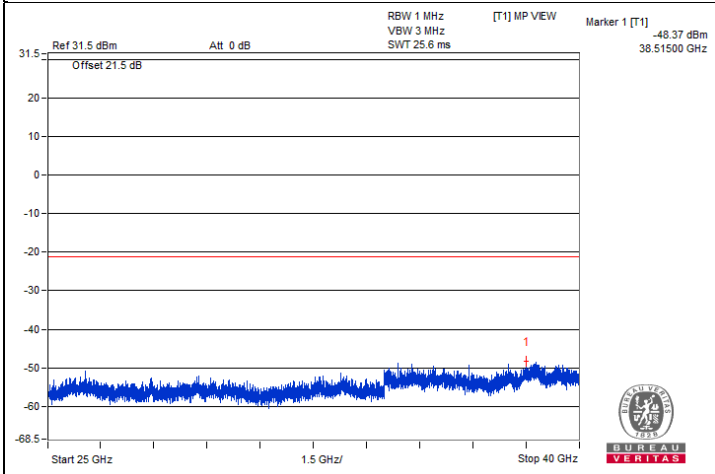
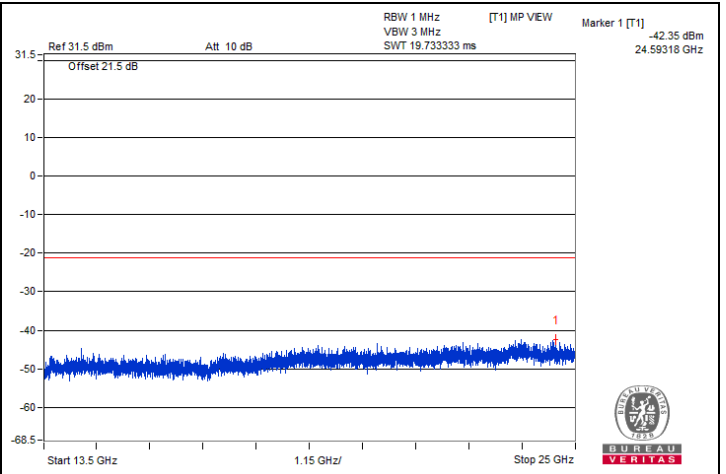
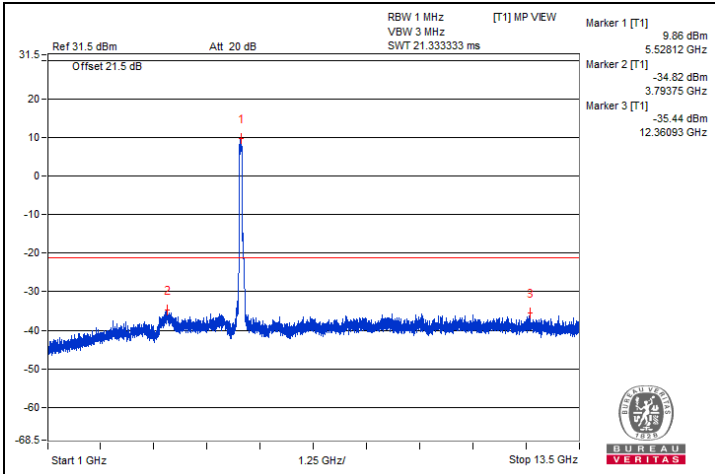

**Bandedge table**

No.	Frequency (MHz)	Emission Level (dBuV/m)	Limit (dBuV/m)	Margin (dB)	Raw Value (dBm)	Correction Factor (dB)	EIRP Level (dBm)
1	5459.31	66.16 PK	74	-7.84	-34.02	4.92	-29.10
2	5459.84	52.46 AV	54	-1.54	-47.72	4.92	-42.80
3	#5468.93	65.56 PK	68.2	-2.64	-34.62	4.92	-29.70

Remarks:

1. Margin value = Emission Level – Limit value
2. The other emission levels were very low against the limit.
3. " # " : The frequency is out of the restricted band.

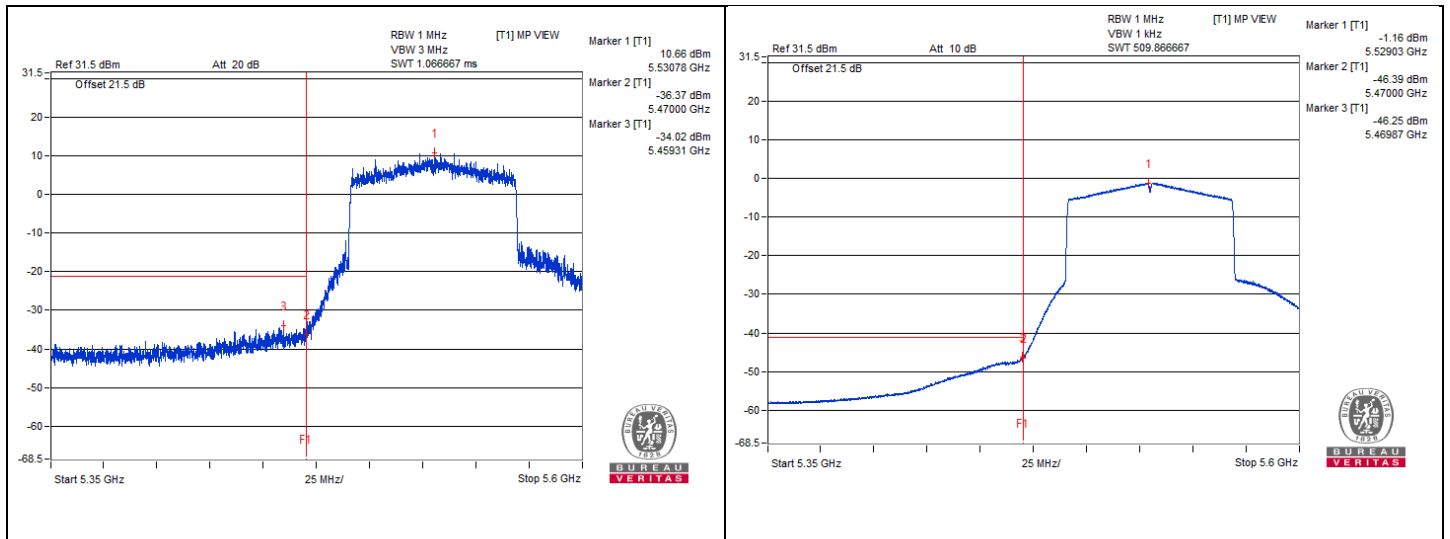

## 802.11be (EHT80) - Channel 122

### Conducted spurious emission table

No.	Frequency (MHz)	Emission Level (dBuV/m)	Limit (dBuV/m)	Margin (dB)	Raw Value (dBm)	Correction Factor (dB)	EIRP Level (dBm)
1	3754.68	64.24 PK	74	-9.76	-35.94	4.92	-31.02
2	3757.81	43.48 AV	54	-10.52	-56.7	4.92	-51.78
3	7481.87	62.01 PK	74	-11.99	-38.17	4.92	-33.25
4	7484.37	40.43 AV	54	-13.57	-59.75	4.92	-54.83
5	11206.25	62.58 PK	74	-11.42	-37.6	4.92	-32.68
6	11212.5	41.12 AV	54	-12.88	-59.06	4.92	-54.14
7	#16817.75	51.47 PK	68.2	-16.73	-48.71	4.92	-43.79

#### Remarks:

1. Margin value = Emission Level – Limit value
2. The other emission levels were very low against the limit.
3. " # " : The frequency is out of the restricted band.

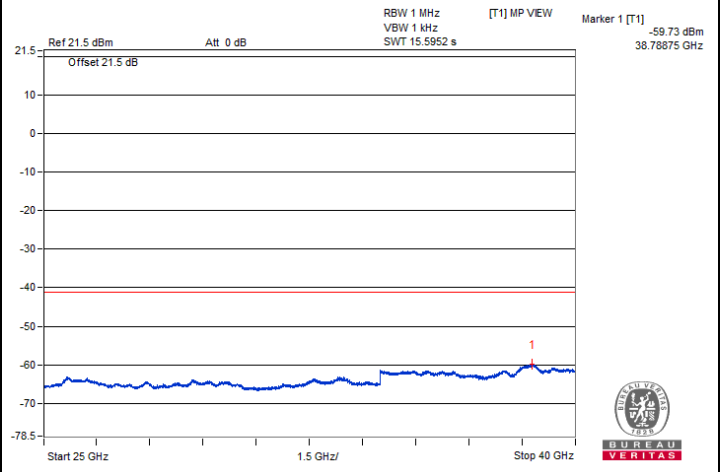
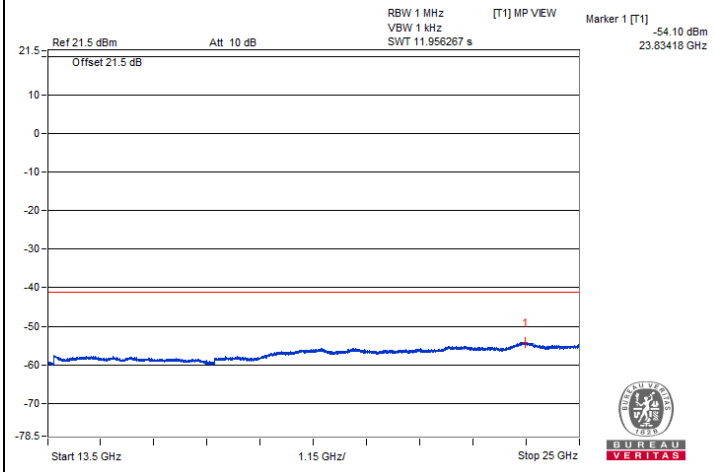
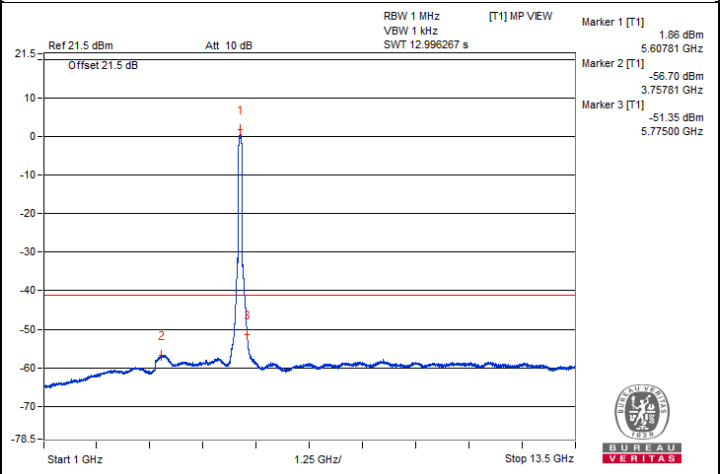
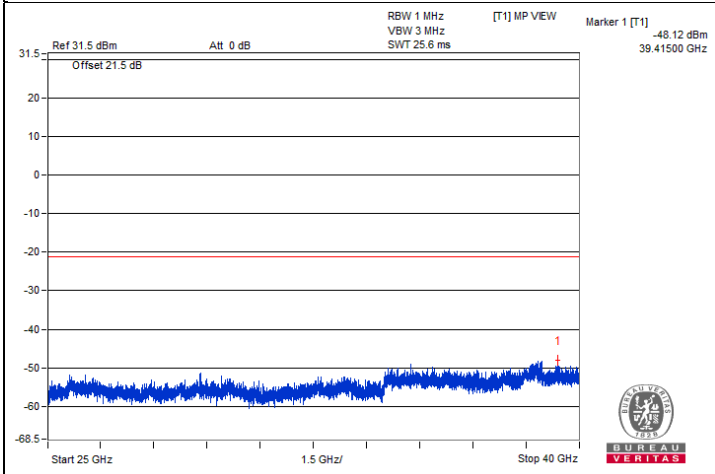
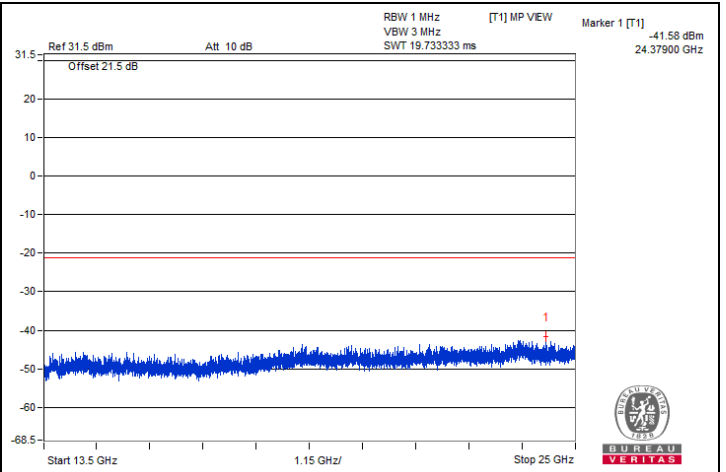
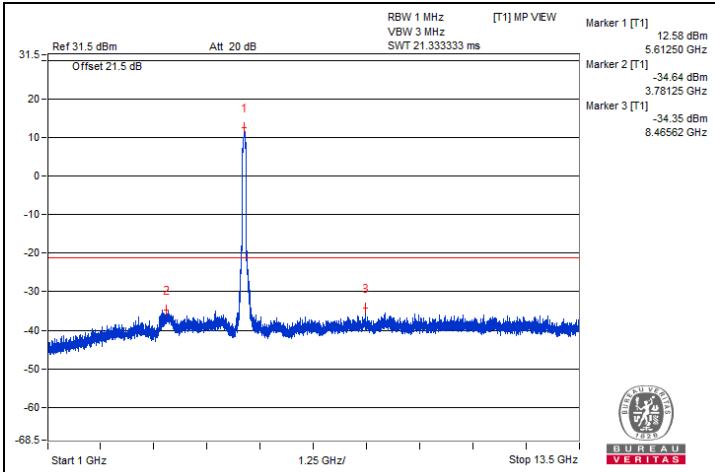





### Bandedge table

No.	Frequency (MHz)	Emission Level (dBuV/m)	Limit (dBuV/m)	Margin (dB)	Raw Value (dBm)	Correction Factor (dB)	EIRP Level (dBm)
1	#5725.55	67.2 PK	68.2	-1	-32.98	4.92	-28.06

Remarks:

1. Margin value = Emission Level – Limit value
2. The other emission levels were very low against the limit.
3. " # " : The frequency is out of the restricted band.

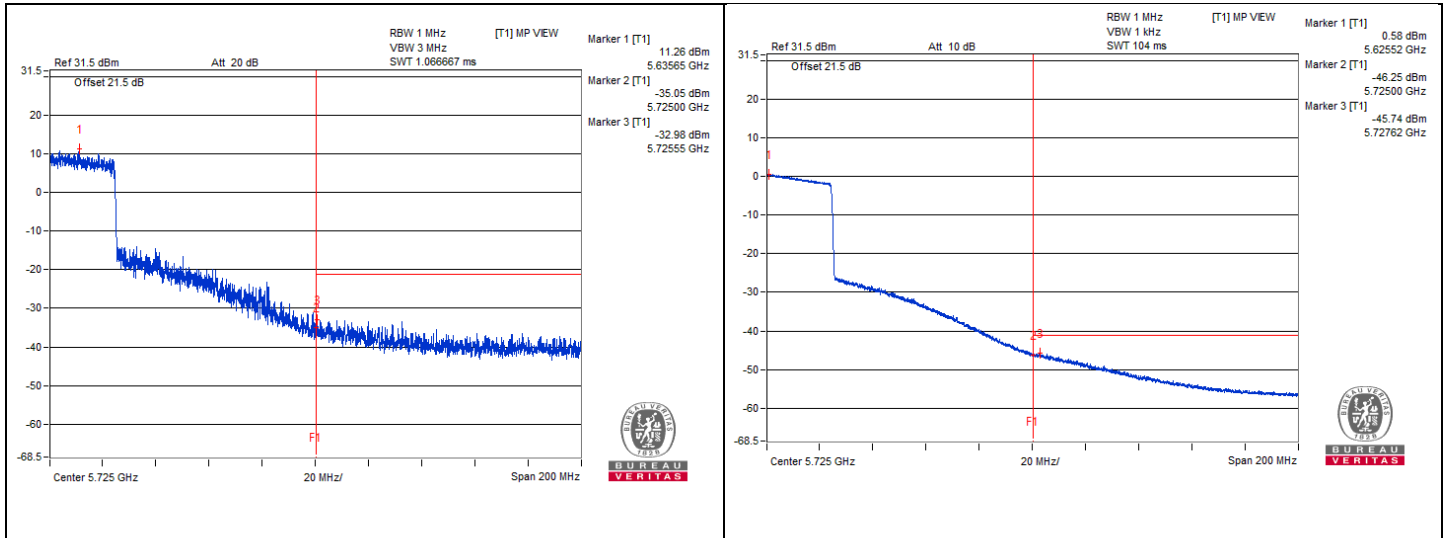

**802.11be (EHT80) - Channel 138**
**Conducted spurious emission table**

No.	Frequency (MHz)	Emission Level (dBuV/m)	Limit (dBuV/m)	Margin (dB)	Raw Value (dBm)	Correction Factor (dB)	EIRP Level (dBm)
1	3740.31	64.46 PK	74	-9.54	-35.72	4.92	-30.80
2	3746.87	43.4 AV	54	-10.6	-56.78	4.92	-51.86
3	7479.68	61.96 PK	74	-12.04	-38.22	4.92	-33.30
4	7485.93	40.42 AV	54	-13.58	-59.76	4.92	-54.84
5	11221.56	62.63 PK	74	-11.37	-37.55	4.92	-32.63
6	11223.43	40.97 AV	54	-13.03	-59.21	4.92	-54.29
7	#16814.87	51.68 PK	68.2	-16.52	-48.5	4.92	-43.58

**Remarks:**

1. Margin value = Emission Level – Limit value
2. The other emission levels were very low against the limit.
3. " # " : The frequency is out of the restricted band.

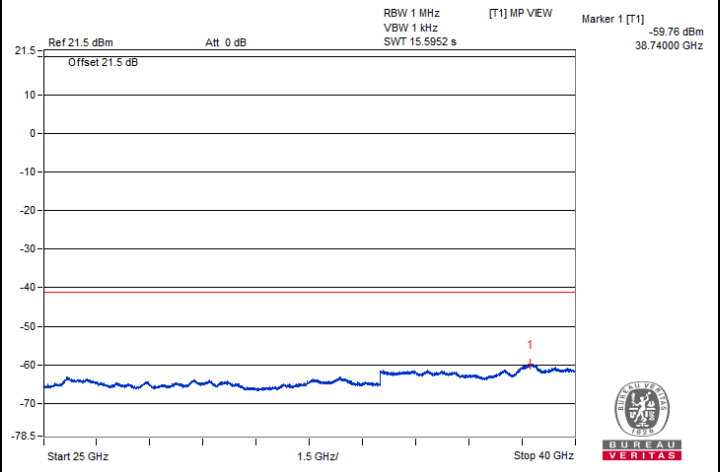
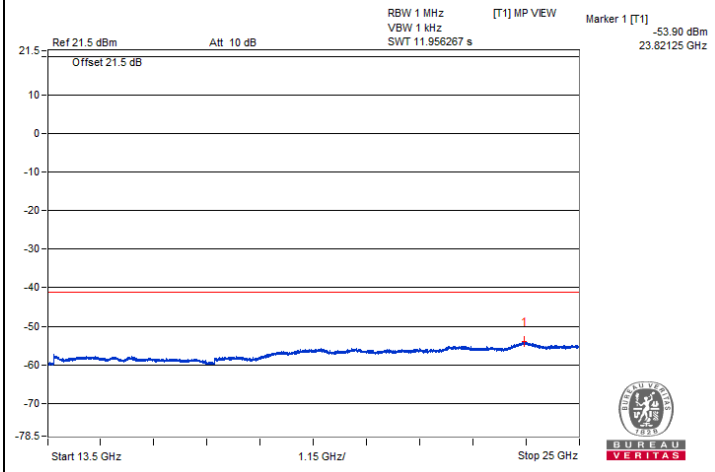
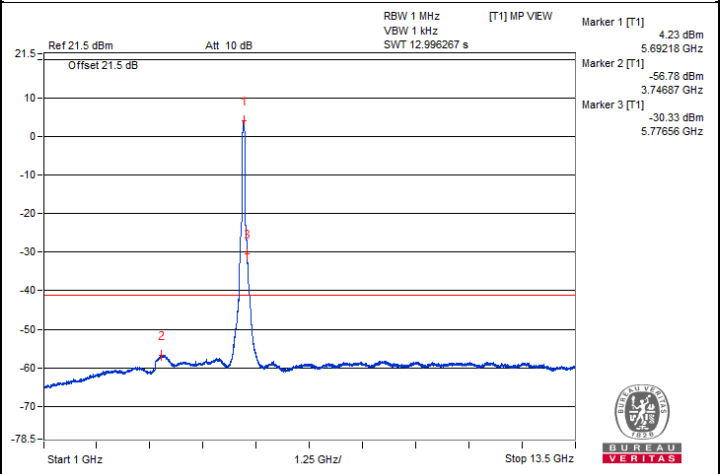
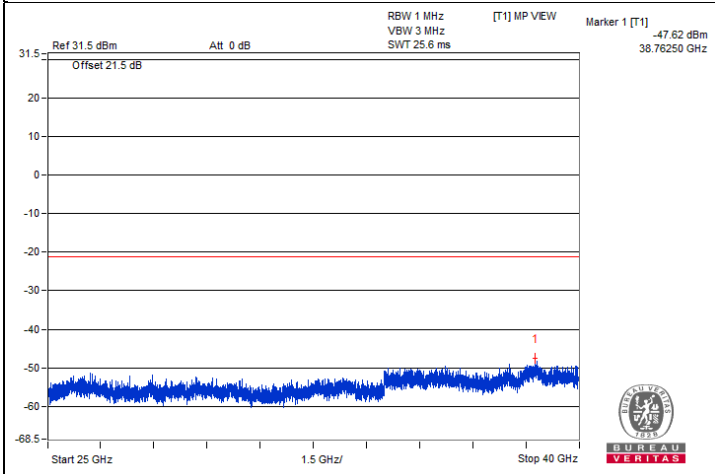
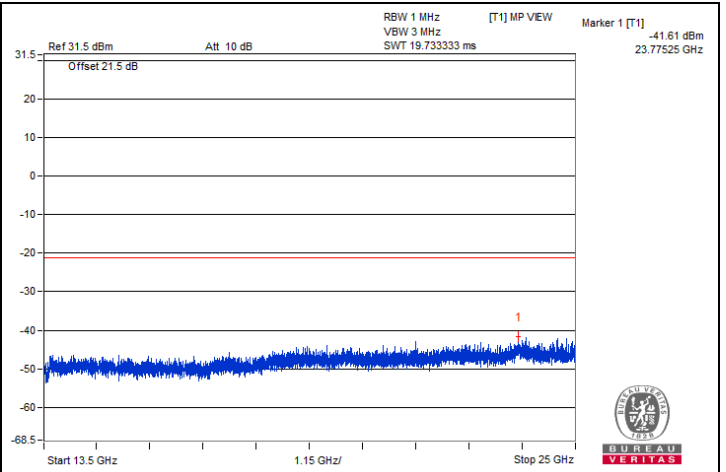
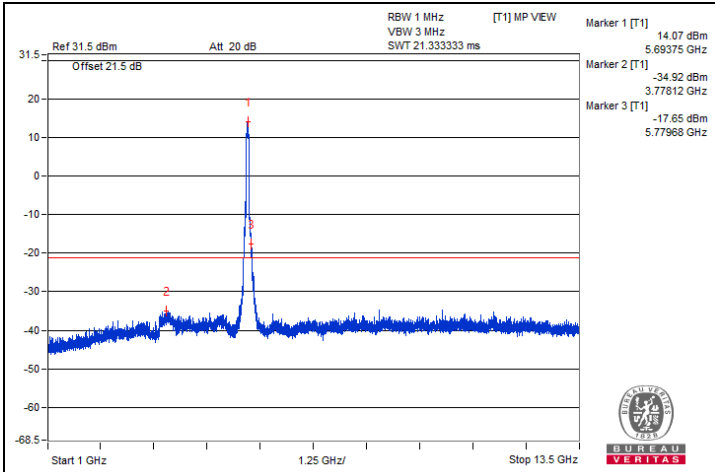

**Bandedge table**

No.	Frequency (MHz)	Emission Level (dBuV/m)	Limit (dBuV/m)	Margin (dB)	Raw Value (dBm)	Correction Factor (dB)	EIRP Level (dBm)
1	#5854.07	68 PK	68.2	-0.2	-32.18	4.92	-27.26

Remarks:

1. Margin value = Emission Level – Limit value
2. The other emission levels were very low against the limit.
3. " # " : The frequency is out of the restricted band.

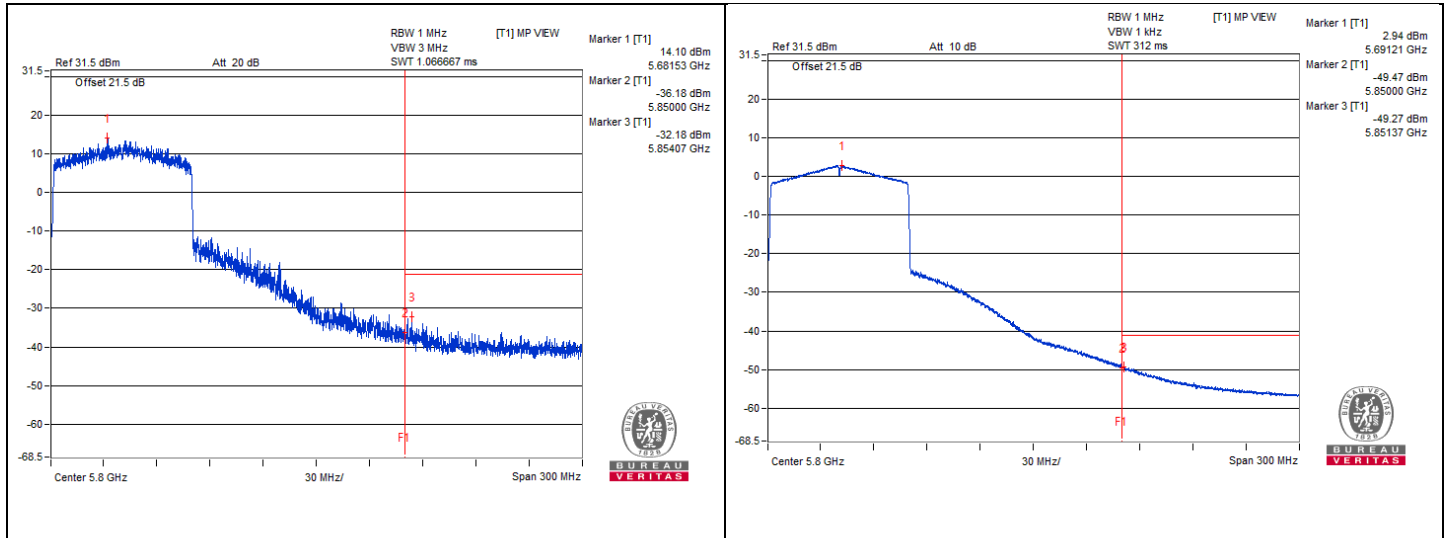

**802.11be (EHT160) - Channel 50**
**Conducted spurious emission table**

No.	Frequency (MHz)	Emission Level (dBuV/m)	Limit (dBuV/m)	Margin (dB)	Raw Value (dBm)	Correction Factor (dB)	EIRP Level (dBm)
1	#3484.37	62.41 PK	68.2	-5.79	-37.77	4.92	-32.85
2	#6982.81	62.33 PK	68.2	-5.87	-37.85	4.92	-32.93
3	#10507.81	63.67 PK	68.2	-4.53	-36.51	4.92	-31.59
4	15745.37	52.14 PK	74	-21.86	-48.04	4.92	-43.12
5	15743.93	41.66 AV	54	-12.34	-58.52	4.92	-53.60

**Remarks:**

1. Margin value = Emission Level – Limit value
2. The other emission levels were very low against the limit.
3. " # " : The frequency is out of the restricted band.

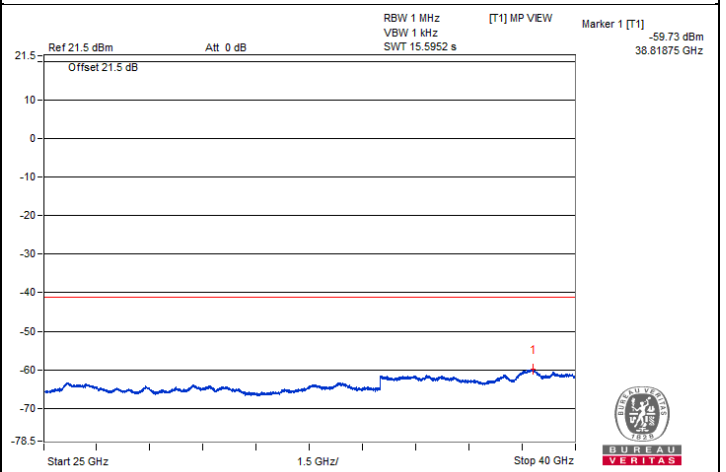
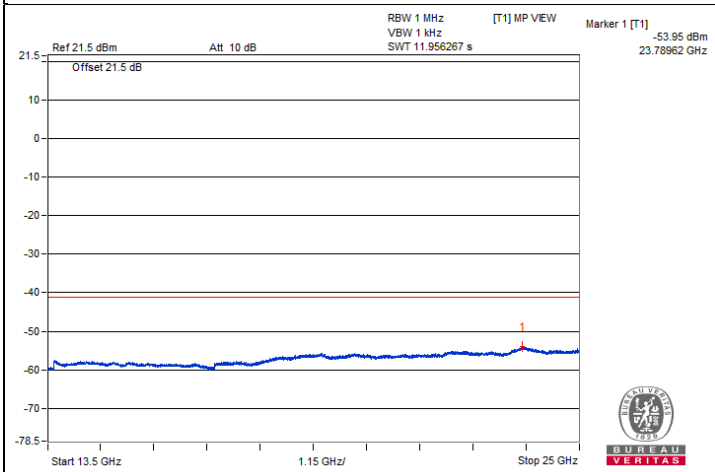
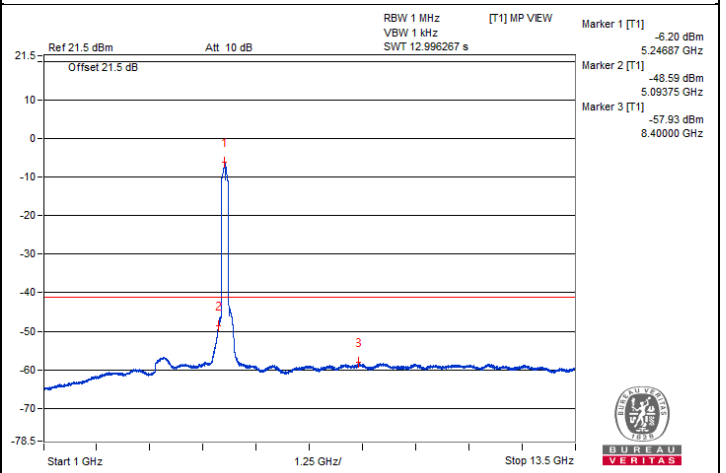
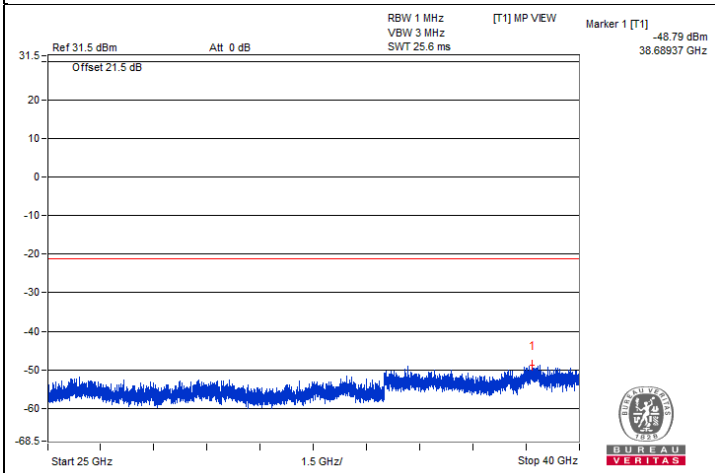
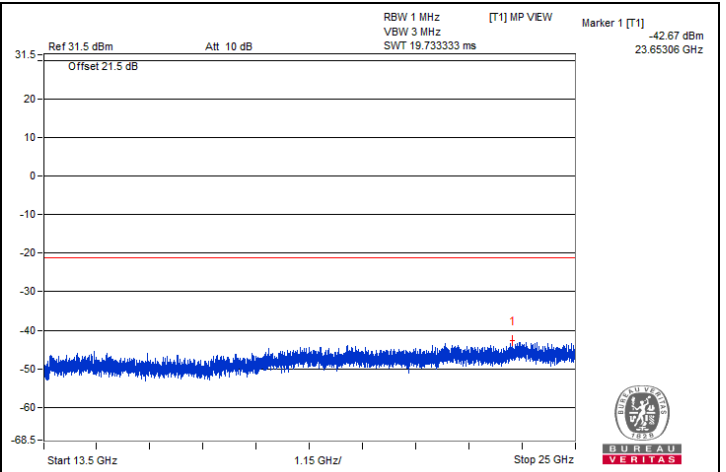
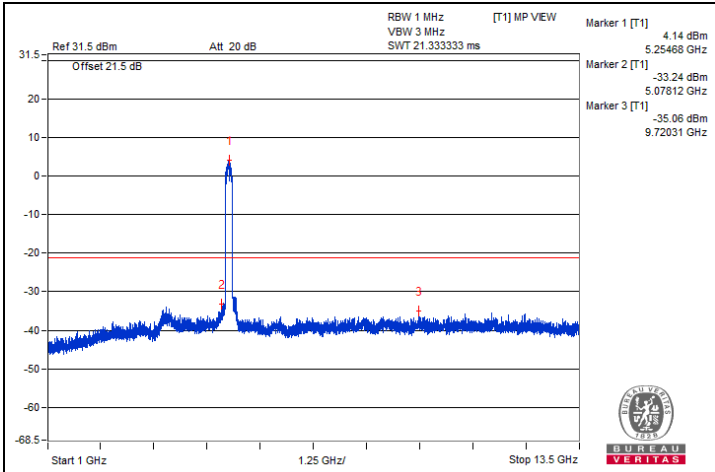

**Bandedge table**

No.	Frequency (MHz)	Emission Level (dBuV/m)	Limit (dBuV/m)	Margin (dB)	Raw Value (dBm)	Correction Factor (dB)	EIRP Level (dBm)
1	5356.3	65.86 PK	74	-8.14	-34.32	4.92	-29.40
2	5363.07	53.39 AV	54	-0.61	-46.79	4.92	-41.87

Remarks:

1. Margin value = Emission Level – Limit value
2. The other emission levels were very low against the limit.

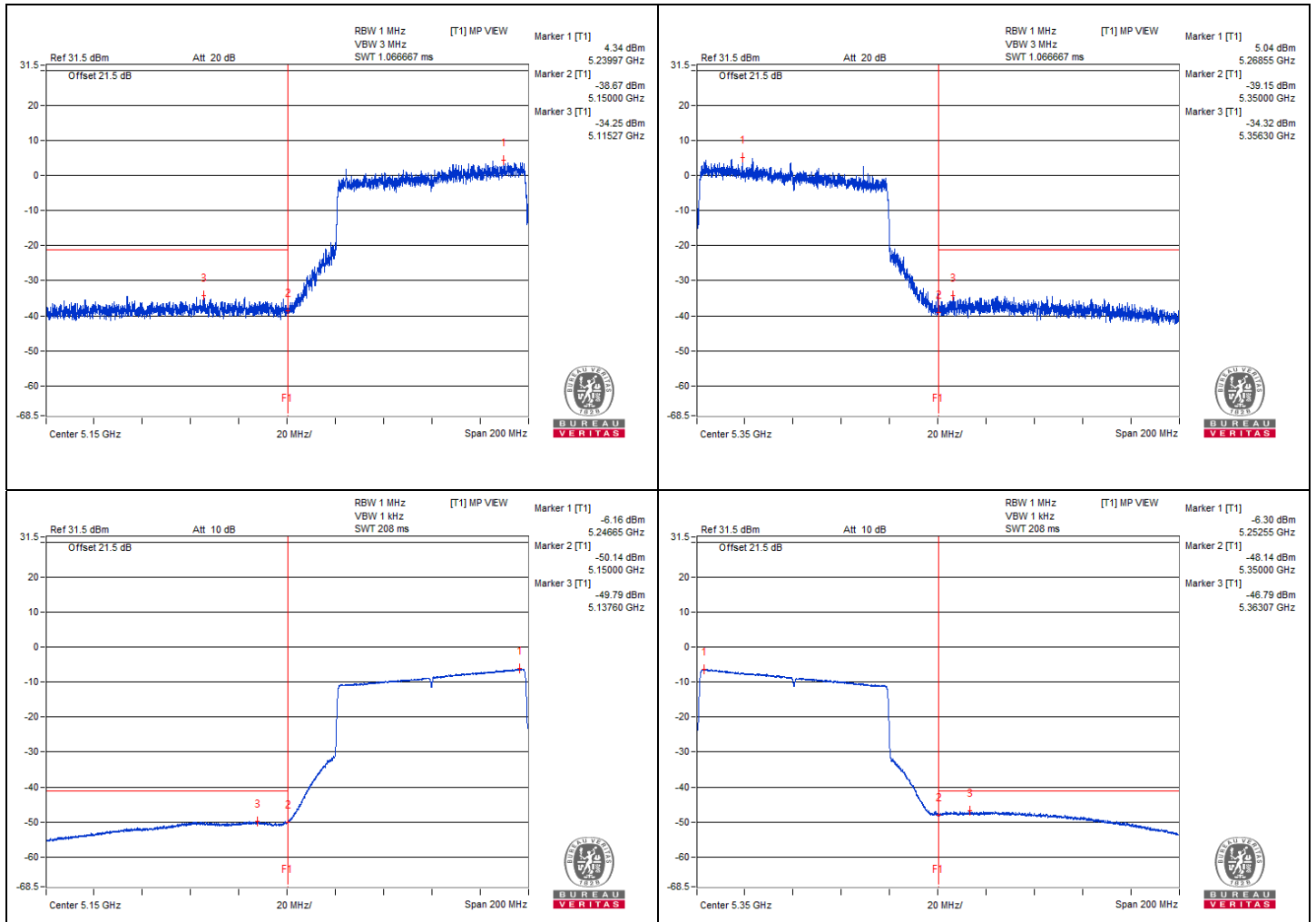

### 802.11be (EHT160) - Channel 114

#### Conducted spurious emission table

No.	Frequency (MHz)	Emission Level (dBuV/m)	Limit (dBuV/m)	Margin (dB)	Raw Value (dBm)	Correction Factor (dB)	EIRP Level (dBm)
1	3725	64.89 PK	74	-9.11	-35.29	4.92	-30.37
2	3725	43.27 AV	54	-10.73	-56.91	4.92	-51.99
3	7424.06	62.95 PK	74	-11.05	-37.23	4.92	-32.31
4	7428.12	40.35 AV	54	-13.65	-59.83	4.92	-54.91
5	11129.68	62.8 PK	74	-11.2	-37.38	4.92	-32.46
6	11123.43	41.24 AV	54	-12.76	-58.94	4.92	-54.02
7	#16691.25	51.84 PK	68.2	-16.36	-48.34	4.92	-43.42

Remarks:

1. Margin value = Emission Level – Limit value
2. The other emission levels were very low against the limit.
3. " # " : The frequency is out of the restricted band.



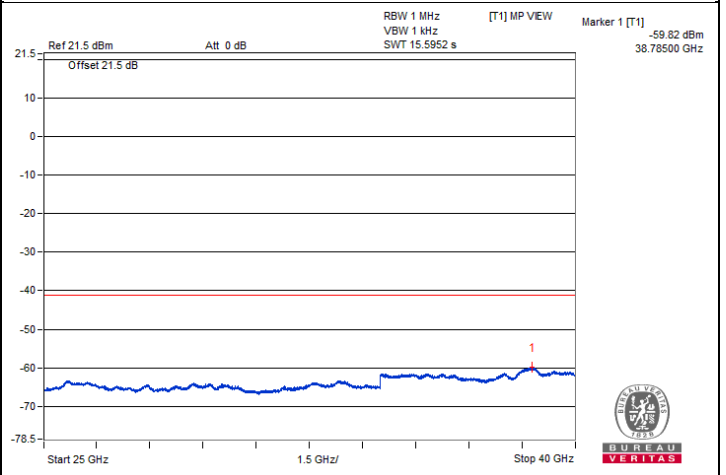
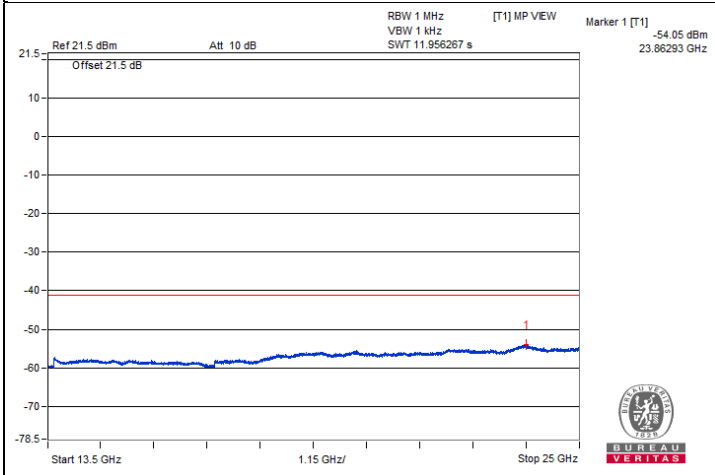
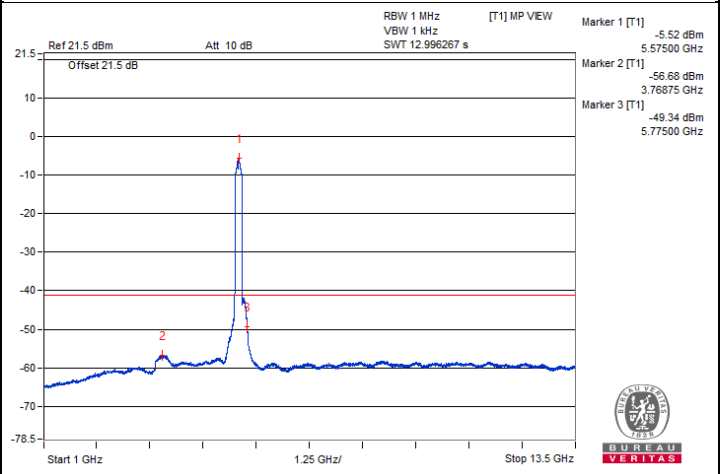
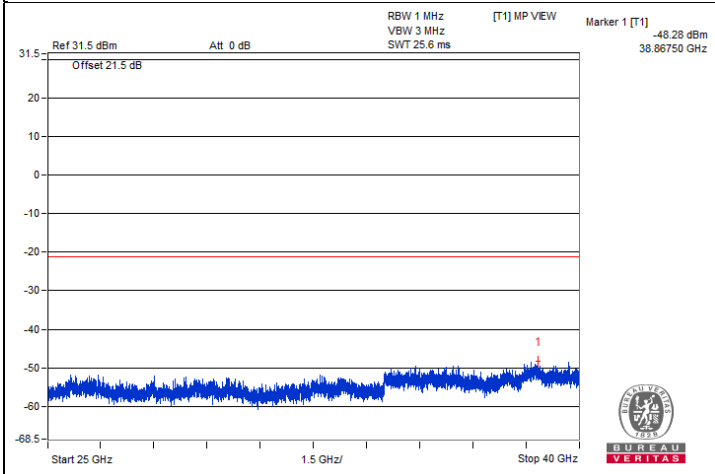
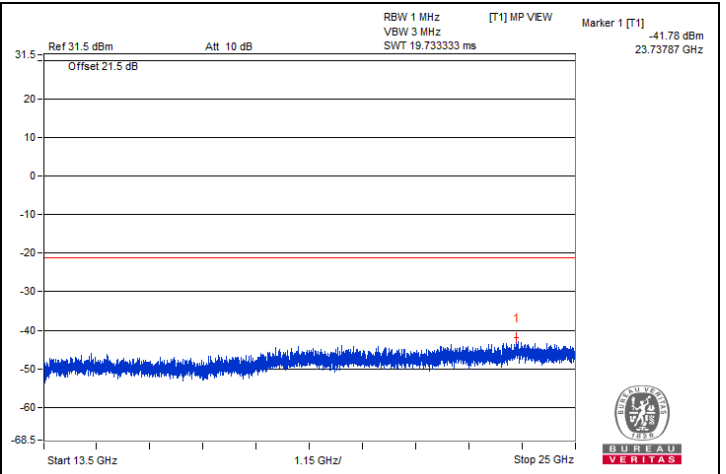
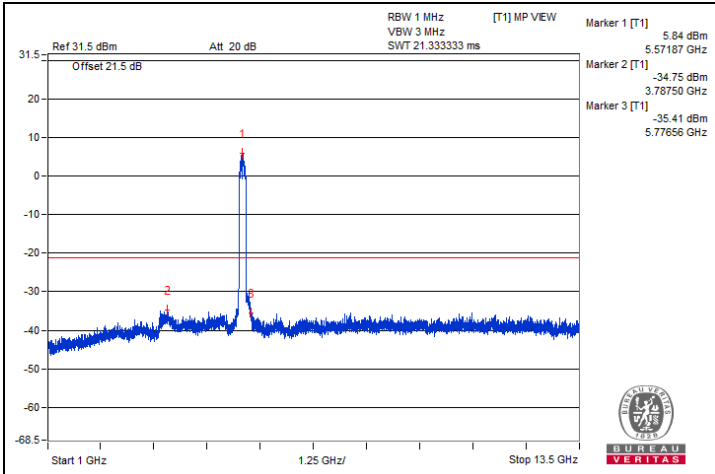

**Bandedge table**

No.	Frequency (MHz)	Emission Level (dBuV/m)	Limit (dBuV/m)	Margin (dB)	Raw Value (dBm)	Correction Factor (dB)	EIRP Level (dBm)
1	#5462.56	65.92 PK	68.2	-2.28	-34.26	4.92	-29.34

Remarks:

1. Margin value = Emission Level – Limit value
2. The other emission levels were very low against the limit.
3. " # " : The frequency is out of the restricted band.

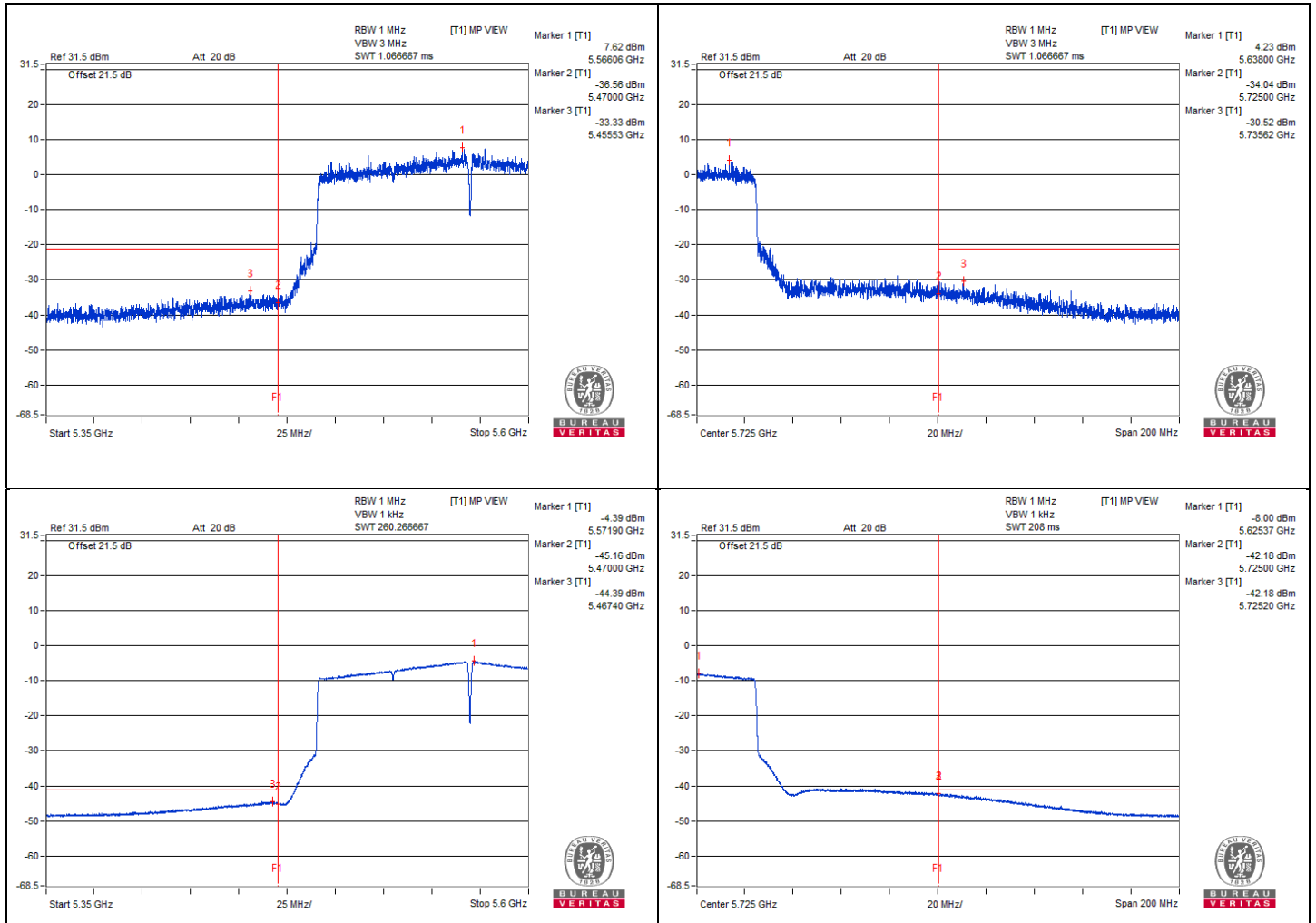

### 802.11be (EHT20) 26-tone RU - Channel 64

#### Conducted spurious emission table

No.	Frequency (MHz)	Emission Level (dBuV/m)	Limit (dBuV/m)	Margin (dB)	Raw Value (dBm)	Correction Factor (dB)	EIRP Level (dBm)
1	3554.68	51.31 PK	74	-22.69	-48.87	4.92	-43.95
2	3559.37	39.58 AV	54	-14.42	-60.6	4.92	-55.68
3	#7104.68	53.63 PK	68.2	-14.57	-46.55	4.92	-41.63
4	10656.68	53.94 PK	74	-20.06	-46.24	4.92	-41.32
5	10656.25	41.55 AV	54	-12.45	-58.63	4.92	-53.71
6	15969.62	52.09 PK	74	-21.91	-48.09	4.92	-43.17
7	15963.87	41.83 AV	54	-12.17	-58.35	4.92	-53.43

Remarks:

1. Margin value = Emission Level – Limit value
2. The other emission levels were very low against the limit.
3. " # " : The frequency is out of the restricted band.

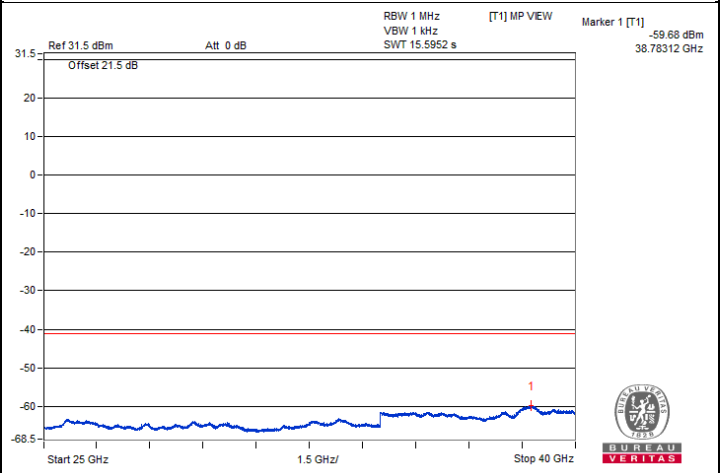
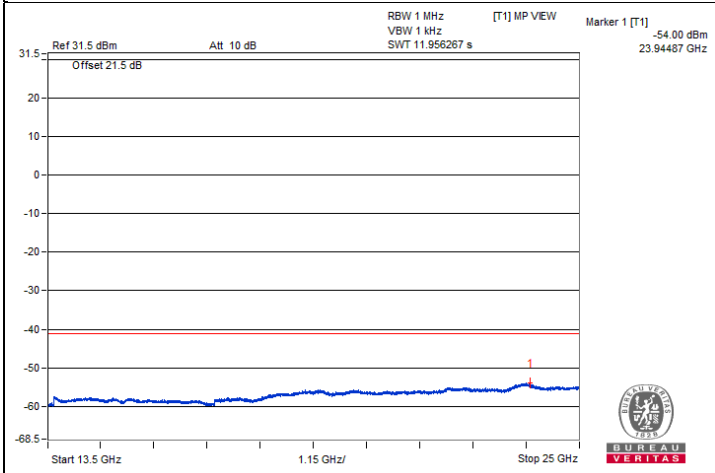
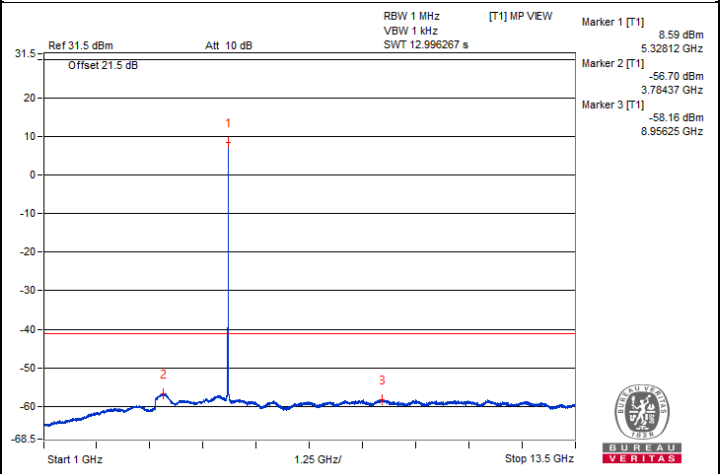
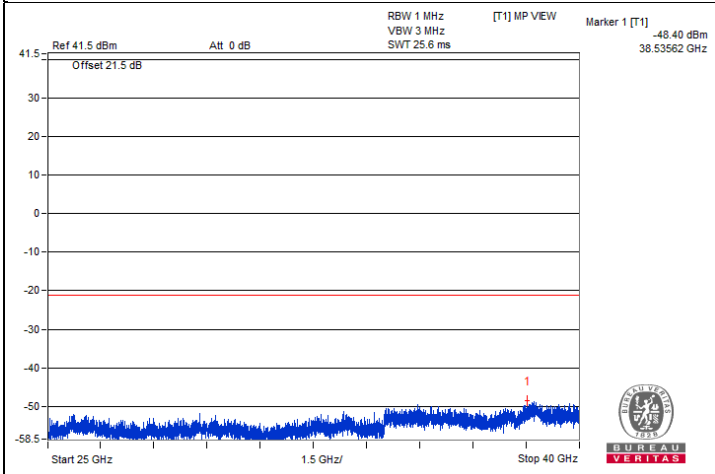
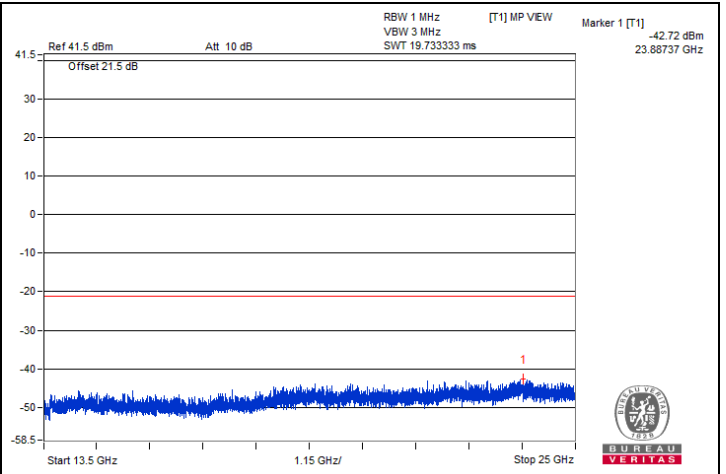
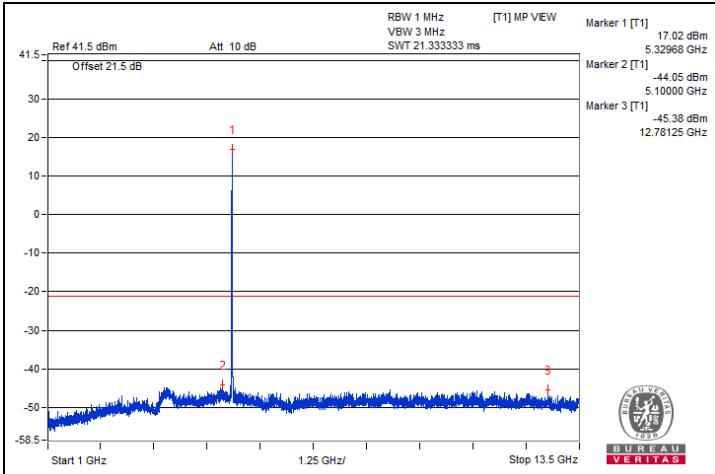

**Bandedge table**

No.	Frequency (MHz)	Emission Level (dBuV/m)	Limit (dBuV/m)	Margin (dB)	Raw Value (dBm)	Correction Factor (dB)	EIRP Level (dBm)
1	5352.3	63.39 PK	74	-10.61	-36.79	4.92	-31.87
2	5352.57	43.2 AV	54	-10.8	-56.98	4.92	-52.06

Remarks:

1. Margin value = Emission Level – Limit value
2. The other emission levels were very low against the limit.

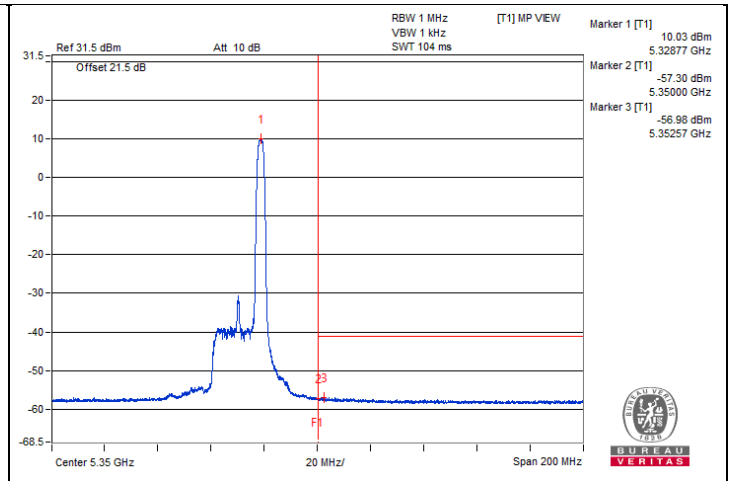
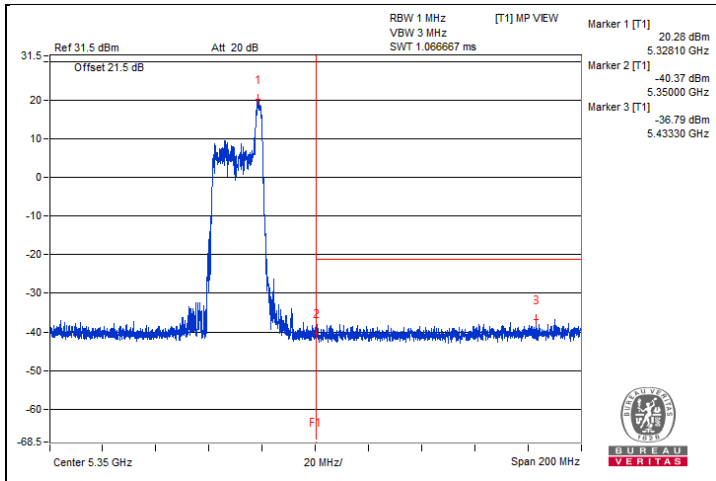

## 802.11be (EHT20) 26-tone RU - Channel 100

### Conducted spurious emission table

No.	Frequency (MHz)	Emission Level (dBuV/m)	Limit (dBuV/m)	Margin (dB)	Raw Value (dBm)	Correction Factor (dB)	EIRP Level (dBm)
1	3685.62	53.63 PK	74	-20.37	-46.55	4.92	-41.63
2	3685.93	42.88 AV	54	-11.12	-57.3	4.92	-52.38
3	7340.62	52.28 PK	74	-21.72	-47.9	4.92	-42.98
4	7340.06	41.02 AV	54	-12.98	-59.16	4.92	-54.24
5	11010.37	53.12 PK	74	-20.88	-47.06	4.92	-42.14
6	11010.93	41.48 AV	54	-12.52	-58.7	4.92	-53.78
7	#16495.75	52.89 PK	68.2	-15.31	-47.29	4.92	-42.37

#### Remarks:

1. Margin value = Emission Level – Limit value
2. The other emission levels were very low against the limit.
3. " # " : The frequency is out of the restricted band.



BUREAU VERITAS

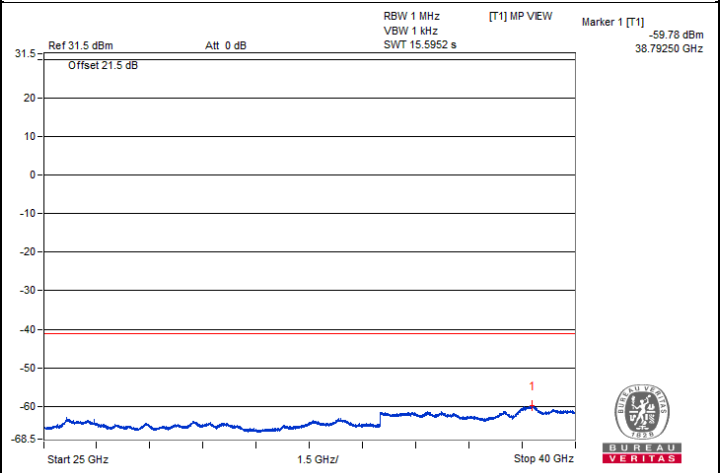
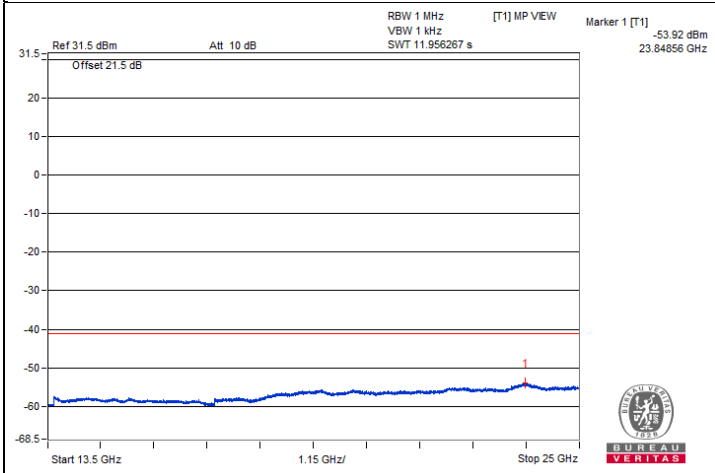
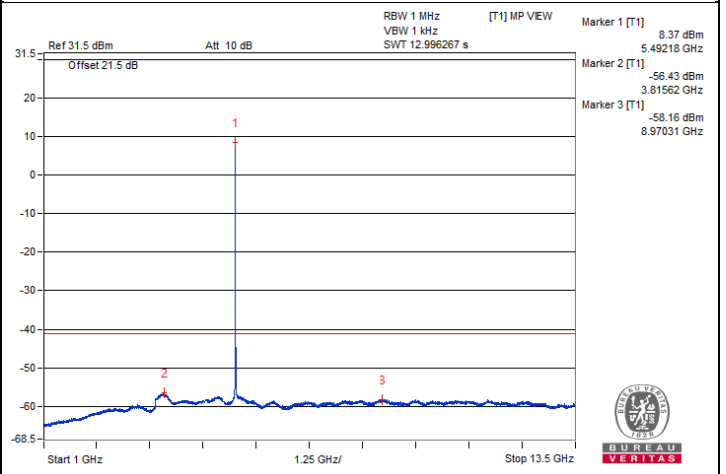
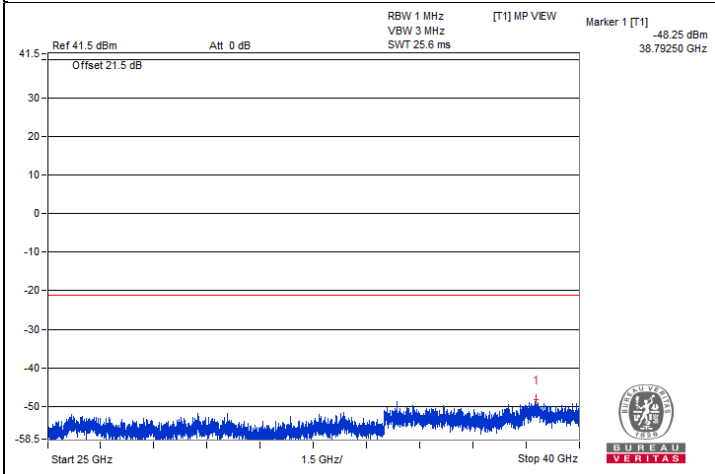
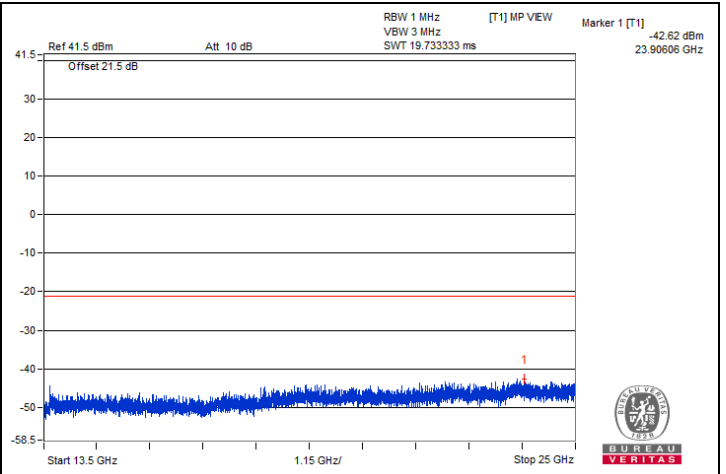
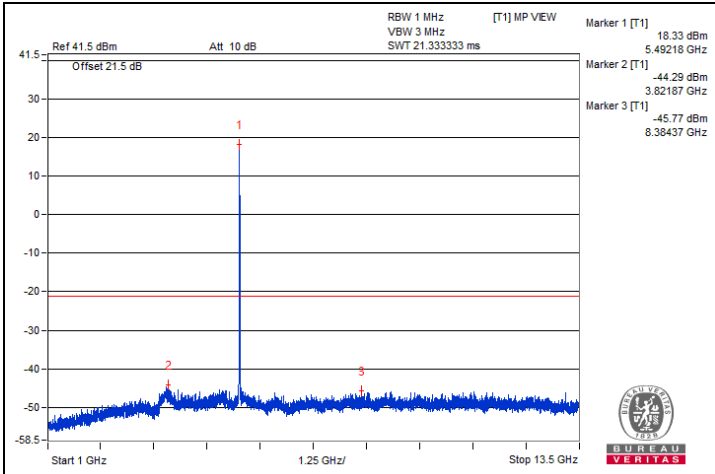

**Bandedge table**

No.	Frequency (MHz)	Emission Level (dBUV/m)	Limit (dBUV/m)	Margin (dB)	Raw Value (dBm)	Correction Factor (dB)	EIRP Level (dBm)
1	5449.4	62.94 PK	74	-11.06	-37.24	4.92	-32.32
2	5457.18	44.03 AV	54	-9.97	-56.15	4.92	-51.23
3	#5462.9	63.33 PK	68.2	-4.87	-36.85	4.92	-31.93

Remarks:

1. Margin value = Emission Level – Limit value
2. The other emission levels were very low against the limit.
3. " # " : The frequency is out of the restricted band.

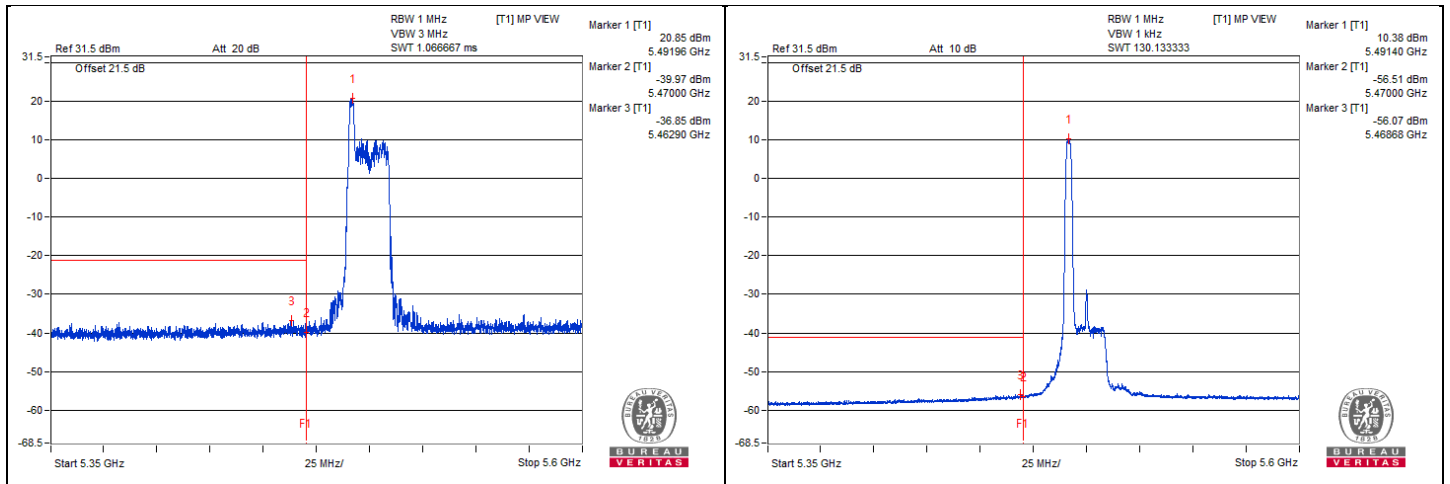



### 802.11be (EHT20) 26-tone RU - Channel 140

#### Conducted spurious emission table

No.	Frequency (MHz)	Emission Level (dBuV/m)	Limit (dBuV/m)	Margin (dB)	Raw Value (dBm)	Correction Factor (dB)	EIRP Level (dBm)
1	3806.25	54.94 PK	74	-19.06	-45.24	4.92	-40.32
2	3812.5	43.52 AV	54	-10.48	-56.66	4.92	-51.74
3	7595.93	52.09 PK	74	-21.91	-48.09	4.92	-43.17
4	7604.68	41 AV	54	-13	-59.18	4.92	-54.26
5	11410.93	53.06 PK	74	-20.94	-47.12	4.92	-42.20
6	11410.62	41.51 AV	54	-12.49	-58.67	4.92	-53.75
7	#17099.5	53.5 PK	68.2	-14.7	-46.68	4.92	-41.76

Remarks:

1. Margin value = Emission Level – Limit value
2. The other emission levels were very low against the limit.
3. " # " : The frequency is out of the restricted band.

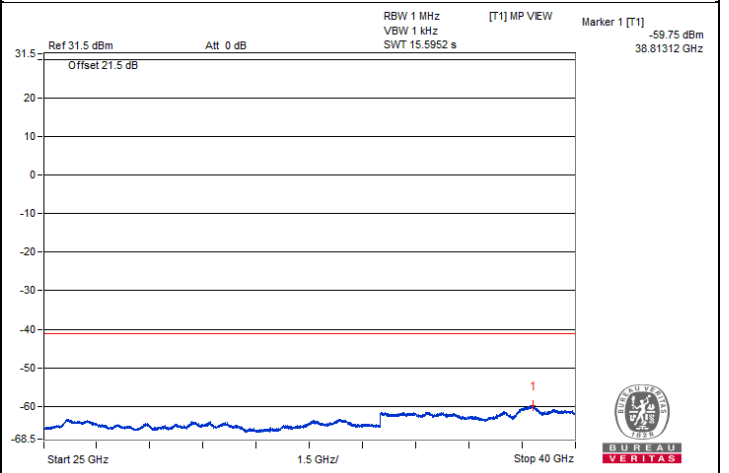
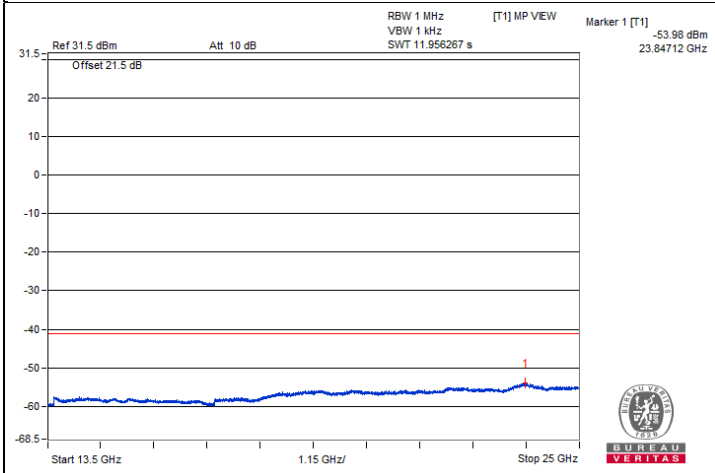
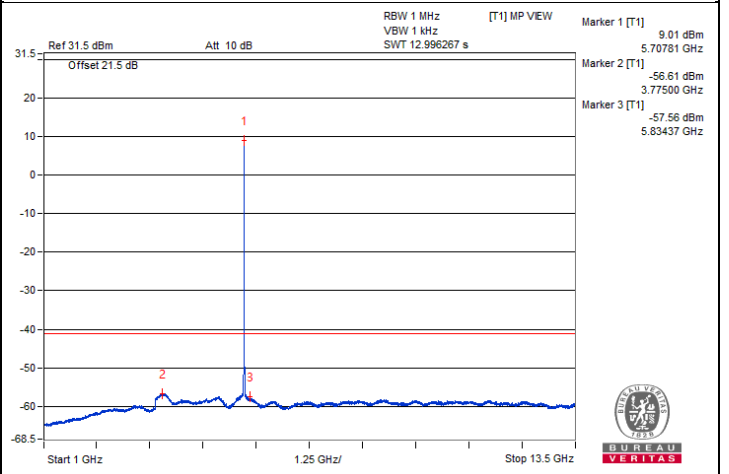
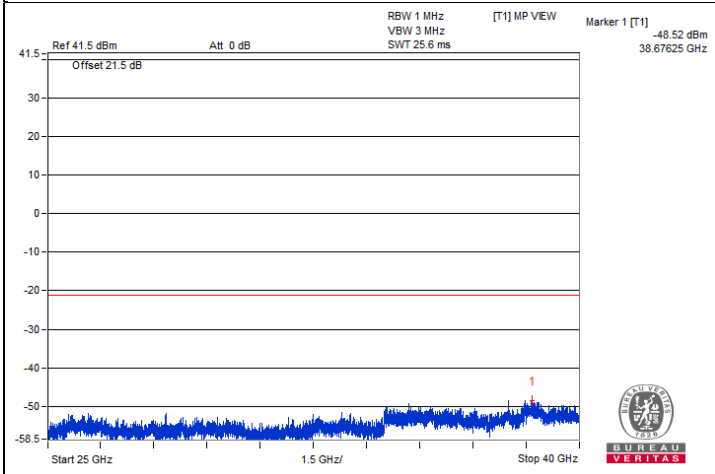
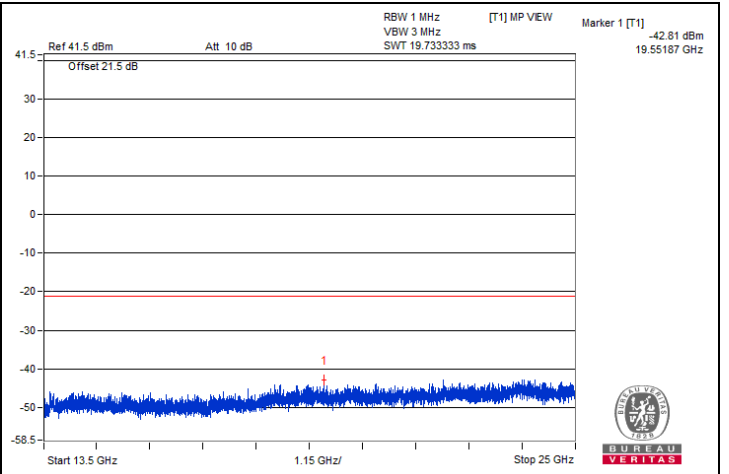
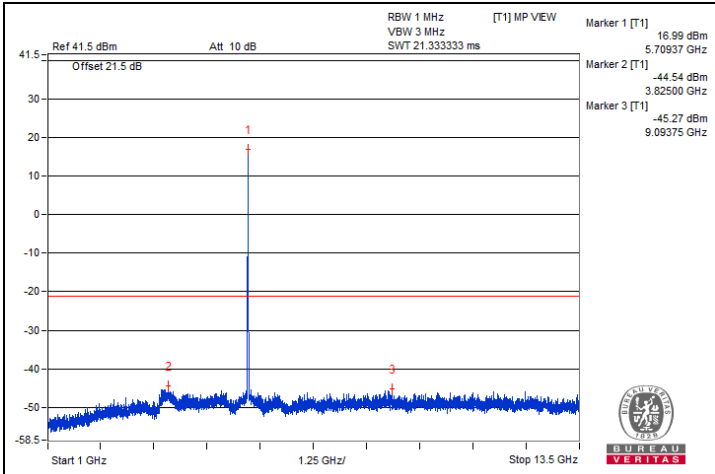

**Bandedge table**

No.	Frequency (MHz)	Emission Level (dBuV/m)	Limit (dBuV/m)	Margin (dB)	Raw Value (dBm)	Correction Factor (dB)	EIRP Level (dBm)
1	#5726.52	64.24 PK	68.2	-3.96	-35.94	4.92	-31.02

Remarks:

1. Margin value = Emission Level – Limit value
2. The other emission levels were very low against the limit.
3. " # " : The frequency is out of the restricted band.

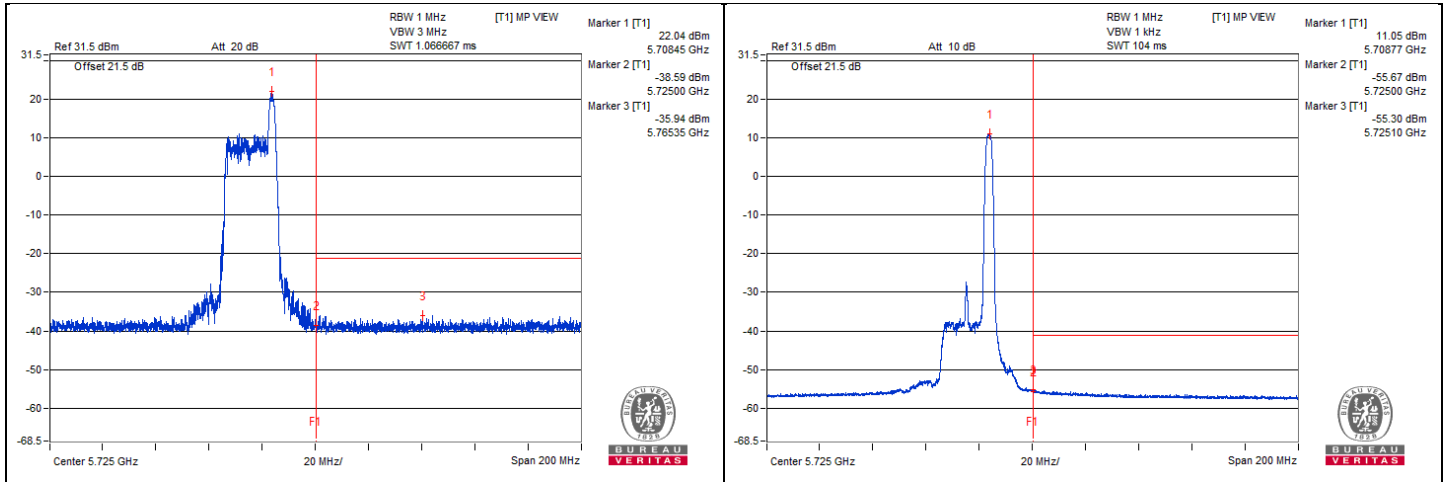

### 802.11be (EHT20) 52-tone RU - Channel 64

#### Conducted spurious emission table

No.	Frequency (MHz)	Emission Level (dBuV/m)	Limit (dBuV/m)	Margin (dB)	Raw Value (dBm)	Correction Factor (dB)	EIRP Level (dBm)
1	3554.68	50.75 PK	74	-23.25	-49.43	4.92	-44.51
2	3548.43	39.5 AV	54	-14.5	-60.68	4.92	-55.76
3	#7101.56	52.69 PK	68.2	-15.51	-47.49	4.92	-42.57
4	10631.25	52.12 PK	74	-21.88	-48.06	4.92	-43.14
5	10625	41.38 AV	54	-12.62	-58.8	4.92	-53.88
6	15968.18	53.55 PK	74	-20.45	-46.63	4.92	-41.71
7	15968.31	41.67 AV	54	-12.33	-58.51	4.92	-53.59

#### Remarks:

1. Margin value = Emission Level – Limit value
2. The other emission levels were very low against the limit.
3. " # " : The frequency is out of the restricted band.

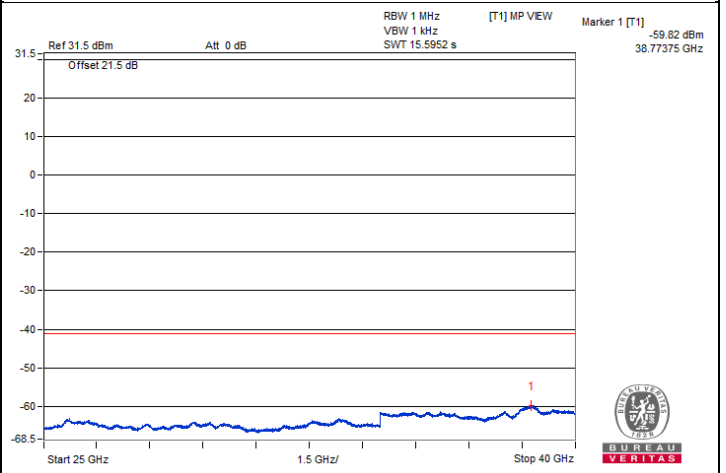
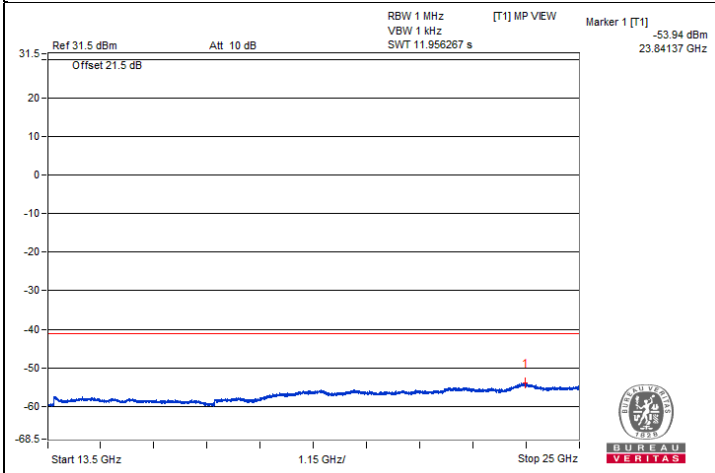
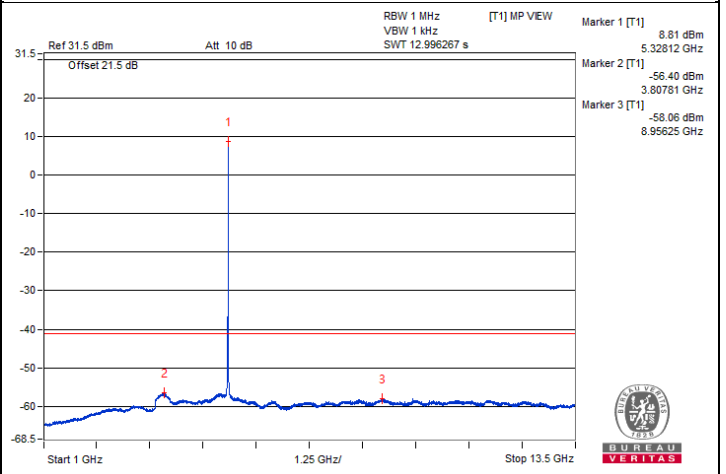
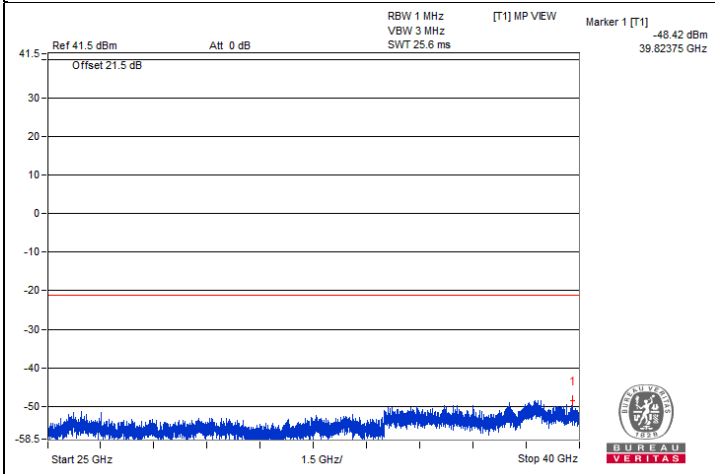
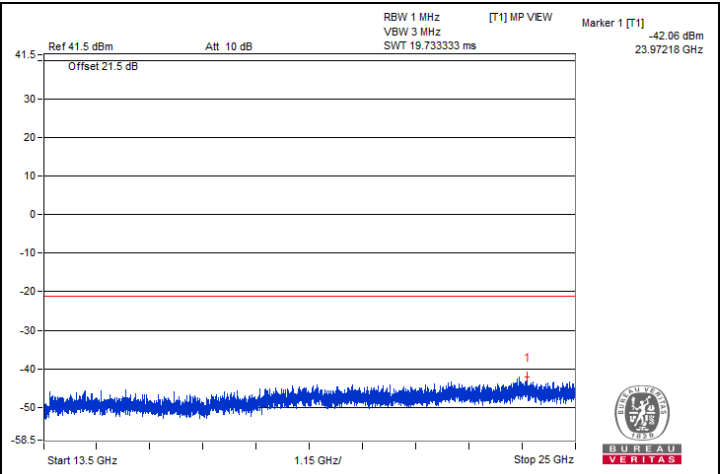
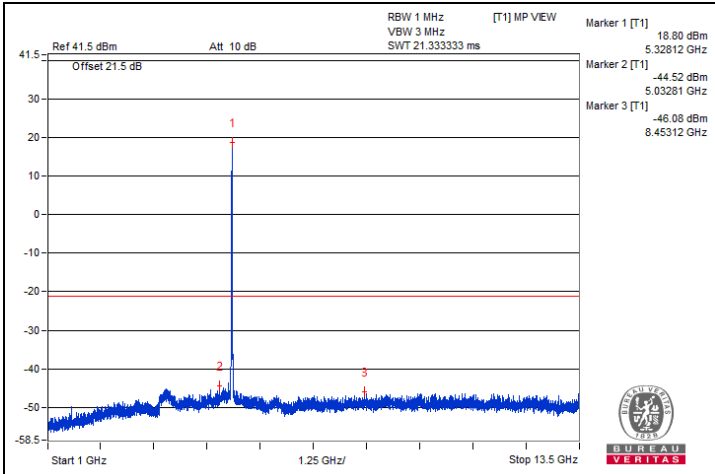

**Bandedge table**

No.	Frequency (MHz)	Emission Level (dBuV/m)	Limit (dBuV/m)	Margin (dB)	Raw Value (dBm)	Correction Factor (dB)	EIRP Level (dBm)
1	5353.67	63.38 PK	74	-10.62	-36.8	4.92	-31.88
2	5356.55	45.56 AV	54	-8.44	-54.62	4.92	-49.70

Remarks:

1. Margin value = Emission Level – Limit value
2. The other emission levels were very low against the limit.

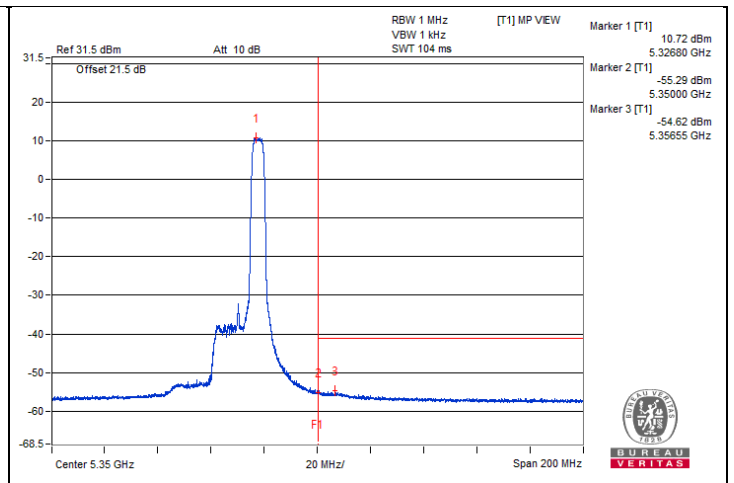
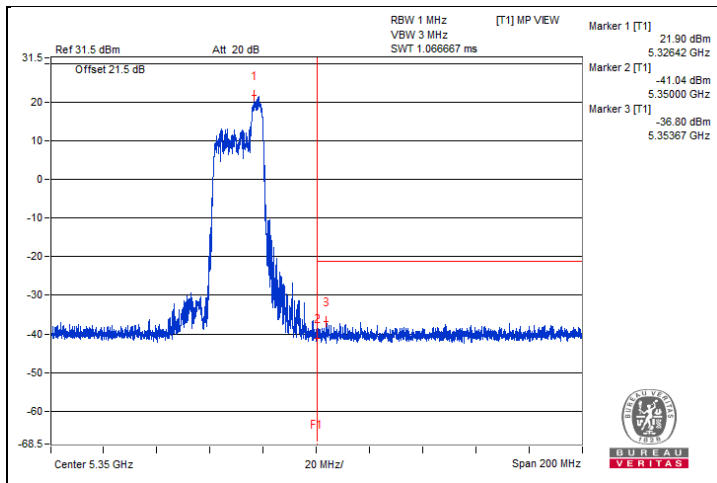

### 802.11be (EHT20) 52-tone RU - Channel 100

#### Conducted spurious emission table

No.	Frequency (MHz)	Emission Level (dBuV/m)	Limit (dBuV/m)	Margin (dB)	Raw Value (dBm)	Correction Factor (dB)	EIRP Level (dBm)
1	3673.43	54.08 PK	74	-19.92	-46.1	4.92	-41.18
2	3673.06	42.85 AV	54	-11.15	-57.33	4.92	-52.41
3	7353.12	52.07 PK	74	-21.93	-48.11	4.92	-43.19
4	7350.31	40.97 AV	54	-13.03	-59.21	4.92	-54.29
5	10984.37	52.82 PK	74	-21.18	-47.36	4.92	-42.44
6	10982.81	41.44 AV	54	-12.56	-58.74	4.92	-53.82
7	#16488.56	51.74 PK	68.2	-16.46	-48.44	4.92	-43.52

Remarks:

1. Margin value = Emission Level – Limit value
2. The other emission levels were very low against the limit.
3. " # " : The frequency is out of the restricted band.



BUREAU  
VERITAS

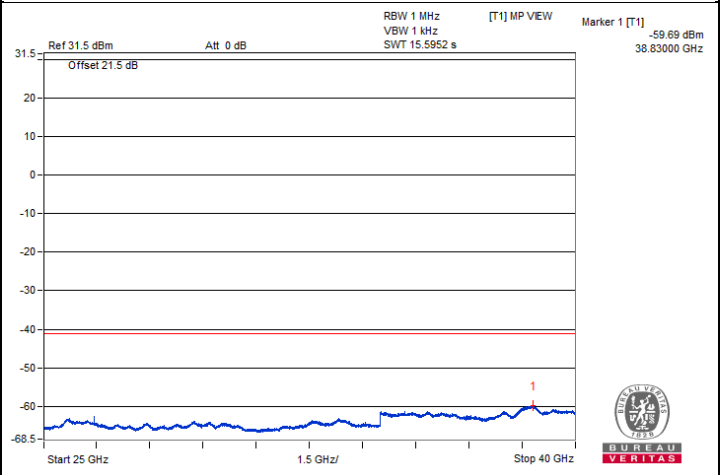
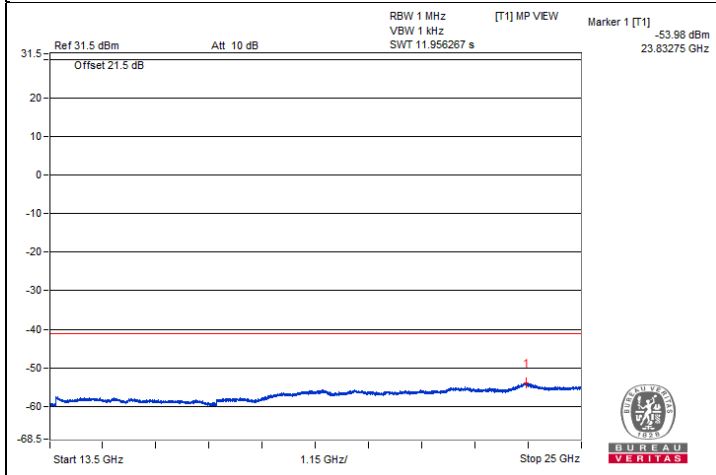
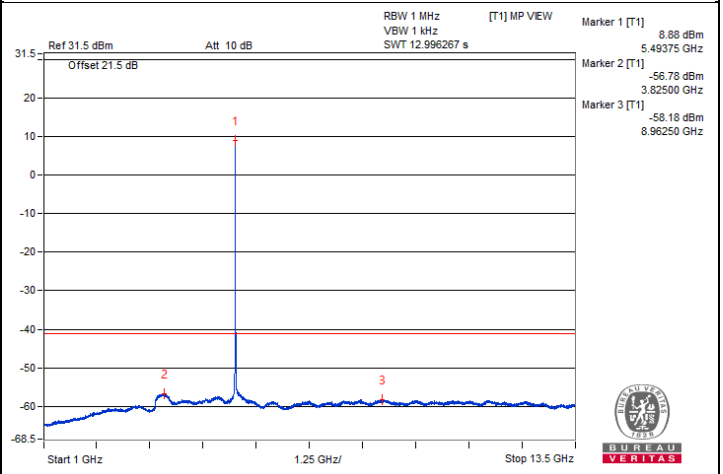
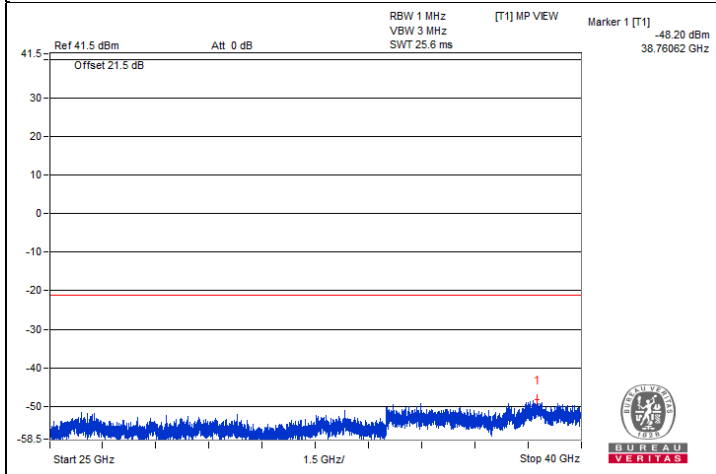
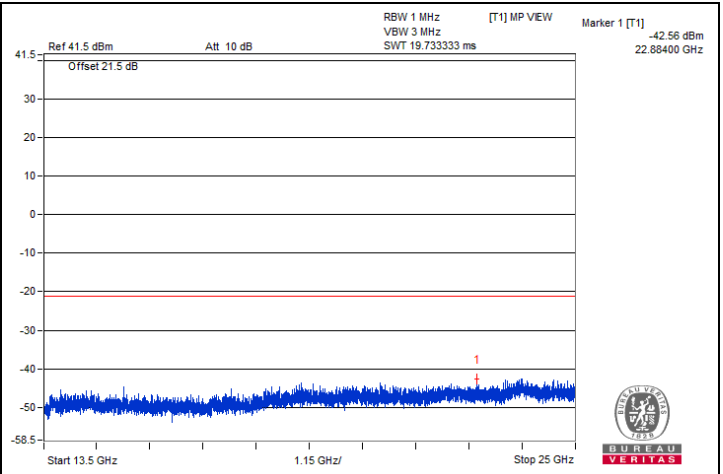
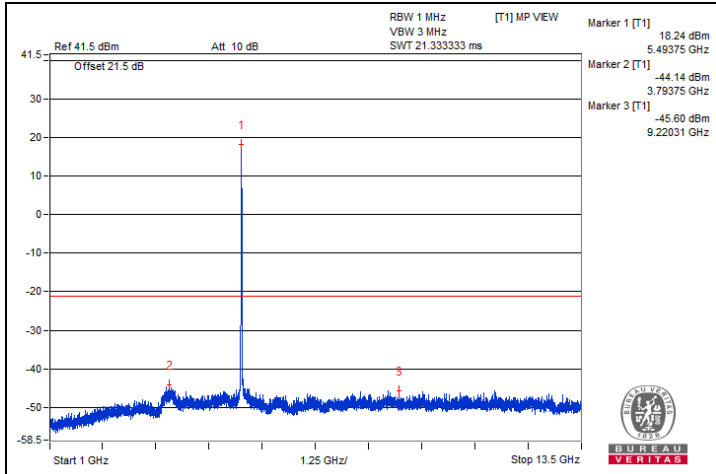



### Bandedge table

No.	Frequency (MHz)	Emission Level (dBUV/m)	Limit (dBUV/m)	Margin (dB)	Raw Value (dBm)	Correction Factor (dB)	EIRP Level (dBm)
1	5459.03	64.28 PK	74	-9.72	-35.9	4.92	-30.98
2	5458.62	44.51 AV	54	-9.49	-55.67	4.92	-50.75
3	#5463.71	64.31 PK	68.2	-3.89	-35.87	4.92	-30.95

Remarks:

1. Margin value = Emission Level – Limit value
2. The other emission levels were very low against the limit.
3. " # " : The frequency is out of the restricted band.

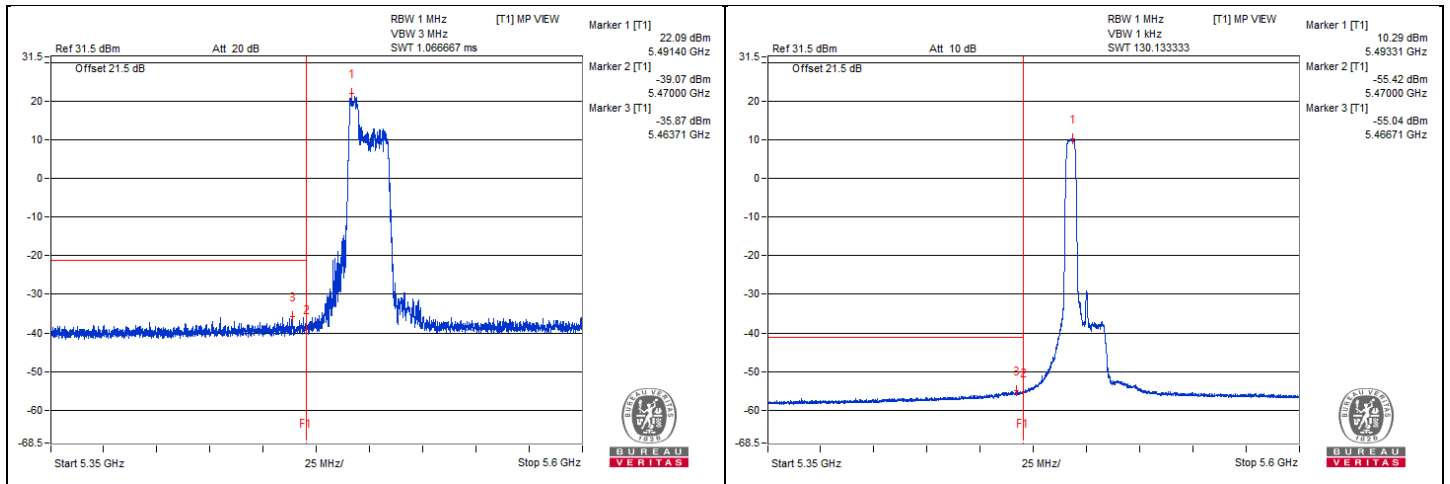

**802.11be (EHT20) 52-tone RU - Channel 140**

**Conducted spurious emission table**

No.	Frequency (MHz)	Emission Level (dBuV/m)	Limit (dBuV/m)	Margin (dB)	Raw Value (dBm)	Correction Factor (dB)	EIRP Level (dBm)
1	3814.06	55.04 PK	74	-18.96	-45.14	4.92	-40.22
2	3814.06	43.41 AV	54	-10.59	-56.77	4.92	-51.85
3	7609.37	53.33 PK	74	-20.67	-46.85	4.92	-41.93
4	7601.56	41.18 AV	54	-12.82	-59	4.92	-54.08
5	11403.12	54.6 PK	74	-19.4	-45.58	4.92	-40.66
6	11403.5	41.54 AV	54	-12.46	-58.64	4.92	-53.72
7	#17102.37	53.48 PK	68.2	-14.72	-46.7	4.92	-41.78

Remarks:

1. Margin value = Emission Level – Limit value
2. The other emission levels were very low against the limit.
3. " # " : The frequency is out of the restricted band.



BUREAU VERITAS

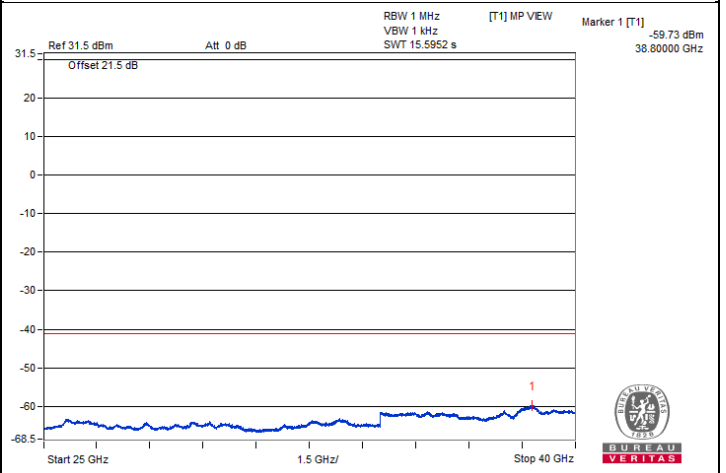
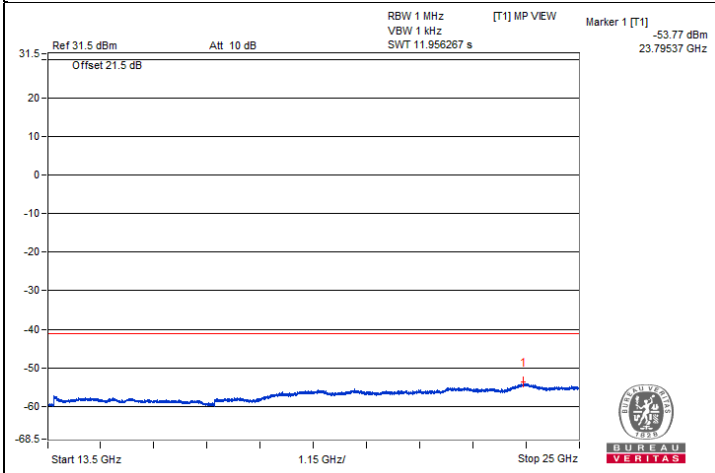
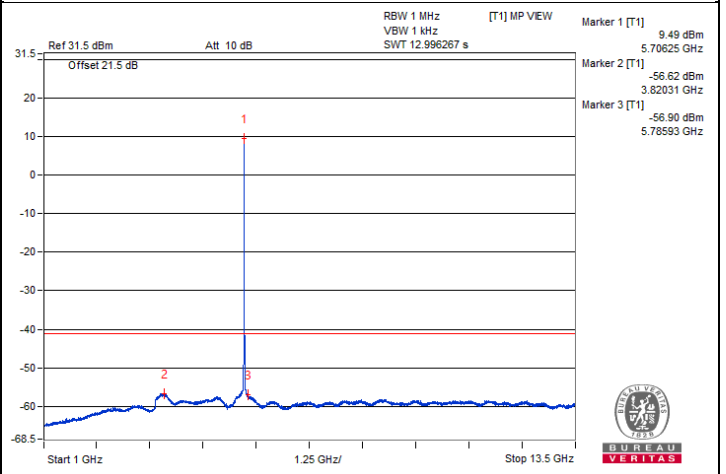
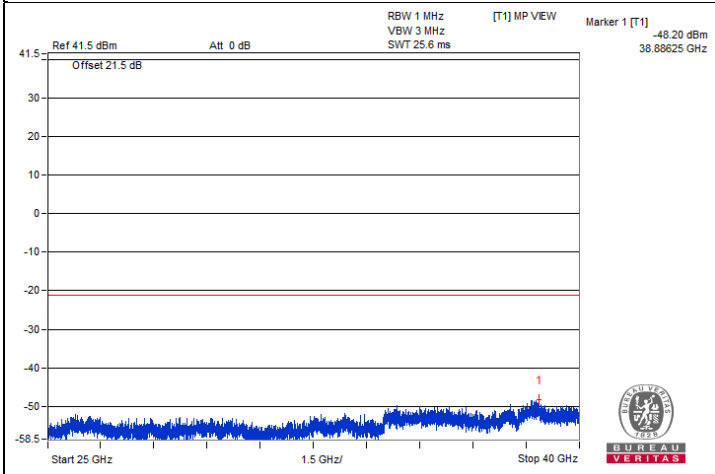
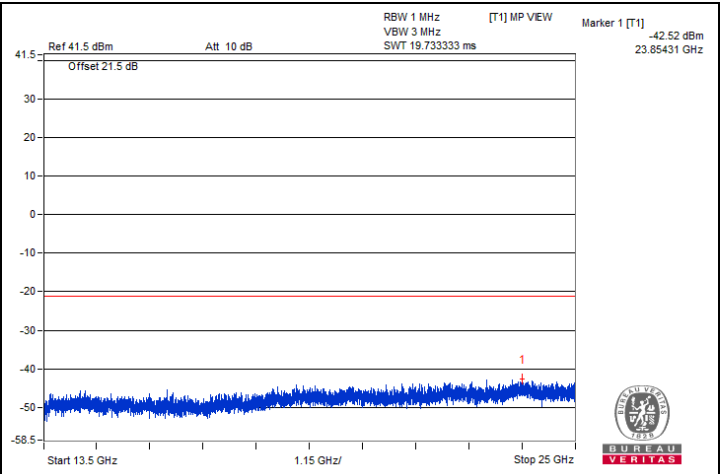
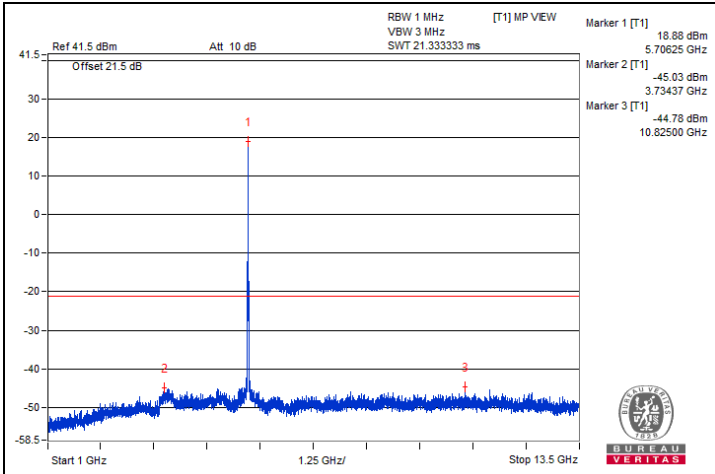

### Bandedge table

No.	Frequency (MHz)	Emission Level (dBuV/m)	Limit (dBuV/m)	Margin (dB)	Raw Value (dBm)	Correction Factor (dB)	EIRP Level (dBm)
1	#5729.77	67.67 PK	68.2	-0.53	-32.51	4.92	-27.59

Remarks:

1. Margin value = Emission Level – Limit value
2. The other emission levels were very low against the limit.
3. "#": The frequency is out of the restricted band.

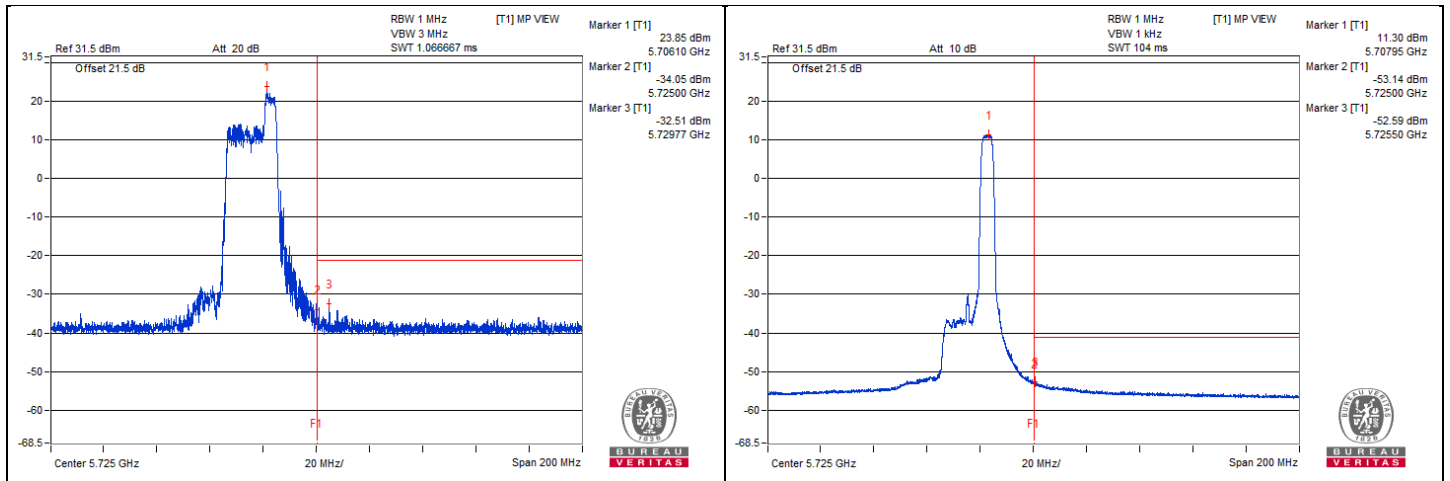

### 802.11be (EHT20) 106-tone RU - Channel 64

#### Conducted spurious emission table

No.	Frequency (MHz)	Emission Level (dBuV/m)	Limit (dBuV/m)	Margin (dB)	Raw Value (dBm)	Correction Factor (dB)	EIRP Level (dBm)
1	3556.25	50.86 PK	74	-23.14	-49.32	4.92	-44.40
2	3556.25	39.64 AV	54	-14.36	-60.54	4.92	-55.62
3	#7089.06	52.16 PK	68.2	-16.04	-48.02	4.92	-43.10
4	10640.62	52.81 PK	74	-21.19	-47.37	4.92	-42.45
5	10637.5	41.51 AV	54	-12.49	-58.67	4.92	-53.75
6	15956.68	53.49 PK	74	-20.51	-46.69	4.92	-41.77
7	15958.12	41.74 AV	54	-12.26	-58.44	4.92	-53.52

#### Remarks:

1. Margin value = Emission Level – Limit value
2. The other emission levels were very low against the limit.
3. " # " : The frequency is out of the restricted band.



BUREAU VERITAS

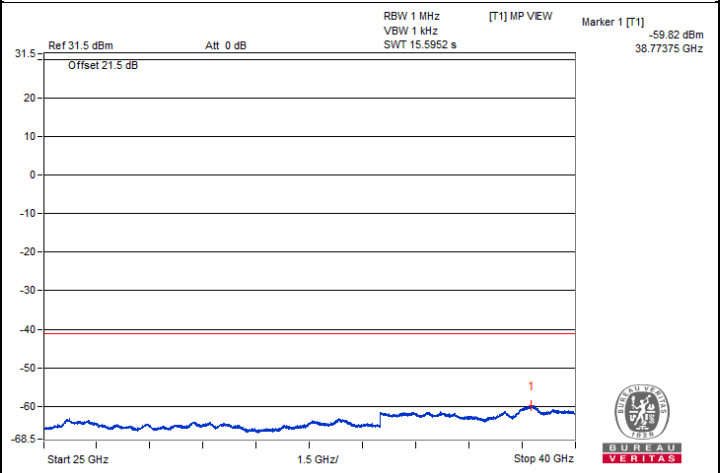
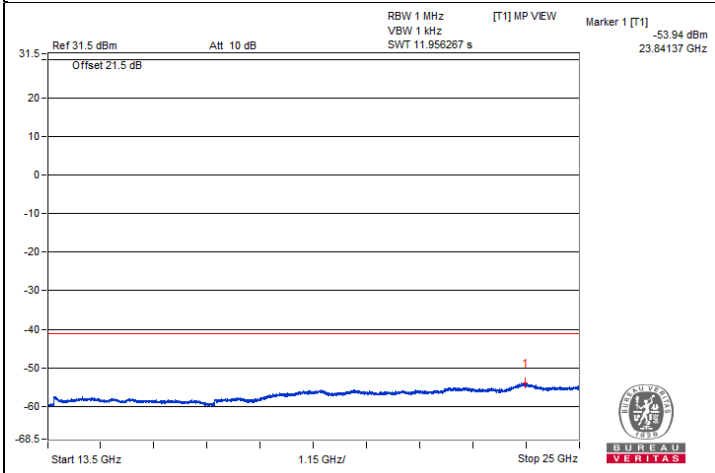
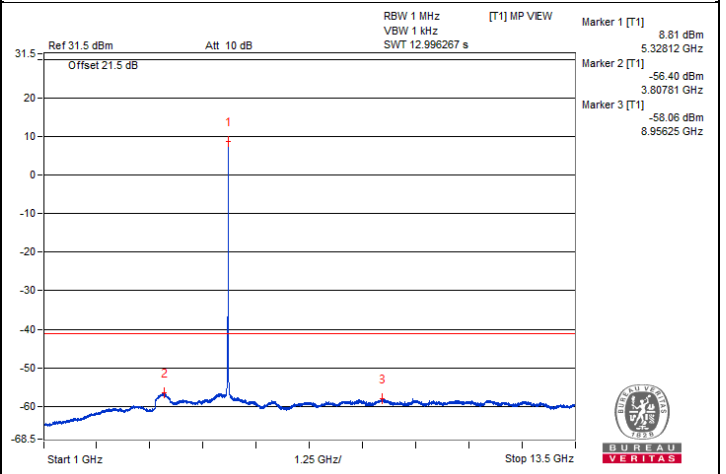
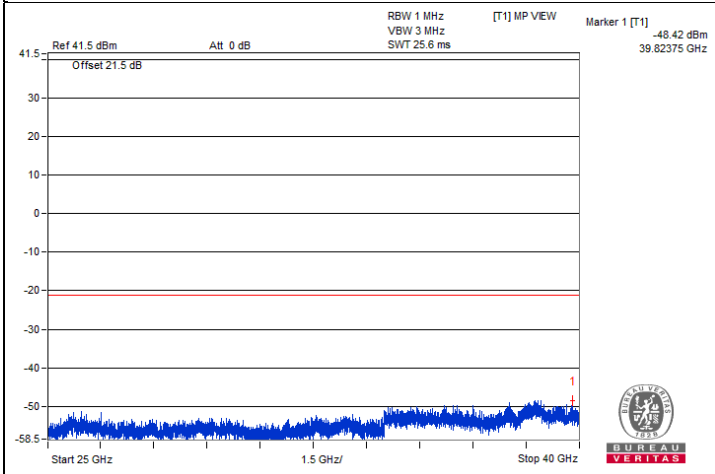
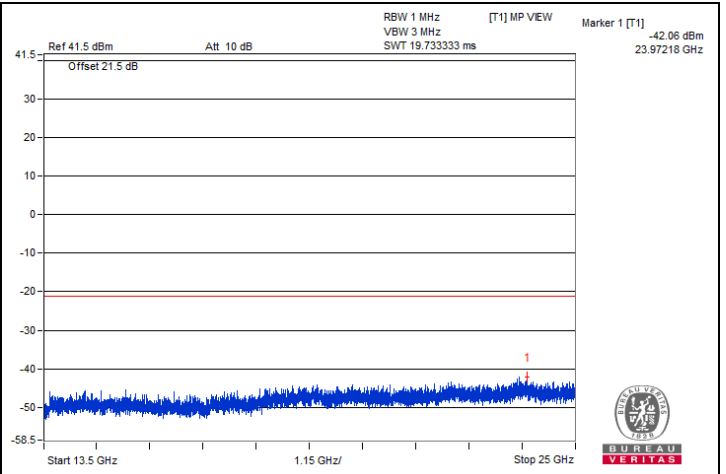
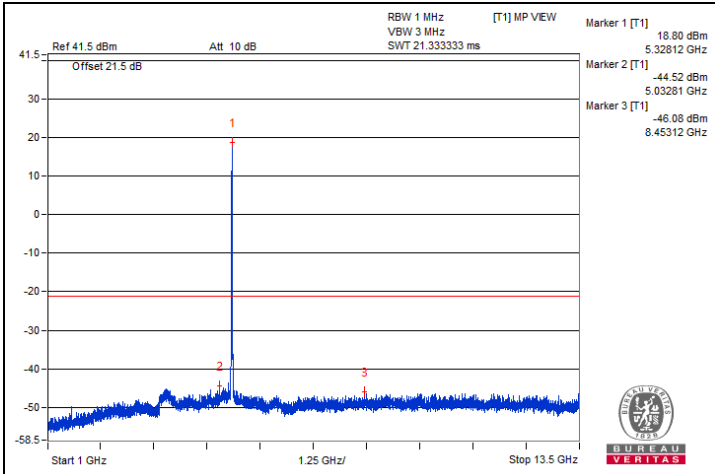

**Bandedge table**

No.	Frequency (MHz)	Emission Level (dBuV/m)	Limit (dBuV/m)	Margin (dB)	Raw Value (dBm)	Correction Factor (dB)	EIRP Level (dBm)
1	5351.7	70.66 PK	74	-3.34	-29.52	4.92	-24.60
2	5350.6	48.62 AV	54	-5.38	-51.56	4.92	-46.64

Remarks:

1. Margin value = Emission Level – Limit value
2. The other emission levels were very low against the limit.

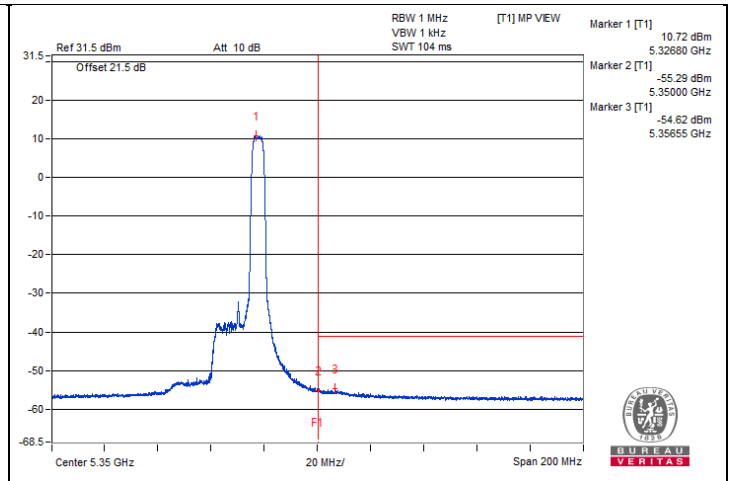
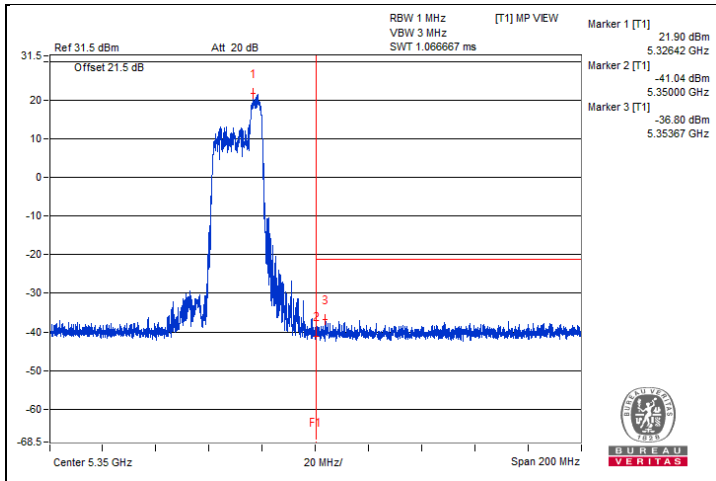

## 802.11be (EHT20) 106-tone RU - Channel 100

### Conducted spurious emission table

No.	Frequency (MHz)	Emission Level (dBuV/m)	Limit (dBuV/m)	Margin (dB)	Raw Value (dBm)	Correction Factor (dB)	EIRP Level (dBm)
1	3674.06	55.34 PK	74	-18.66	-44.84	4.92	-39.92
2	3676.56	42.82 AV	54	-11.18	-57.36	4.92	-52.44
3	7342.18	51.9 PK	74	-22.1	-48.28	4.92	-43.36
4	7342.06	41.1 AV	54	-12.9	-59.08	4.92	-54.16
5	11006.25	53.08 PK	74	-20.92	-47.1	4.92	-42.18
6	11006.25	41.53 AV	54	-12.47	-58.65	4.92	-53.73
7	#16491.43	51.84 PK	68.2	-16.36	-48.34	4.92	-43.42

#### Remarks:

1. Margin value = Emission Level – Limit value
2. The other emission levels were very low against the limit.
3. " # " : The frequency is out of the restricted band.





BUREAU  
VERITAS

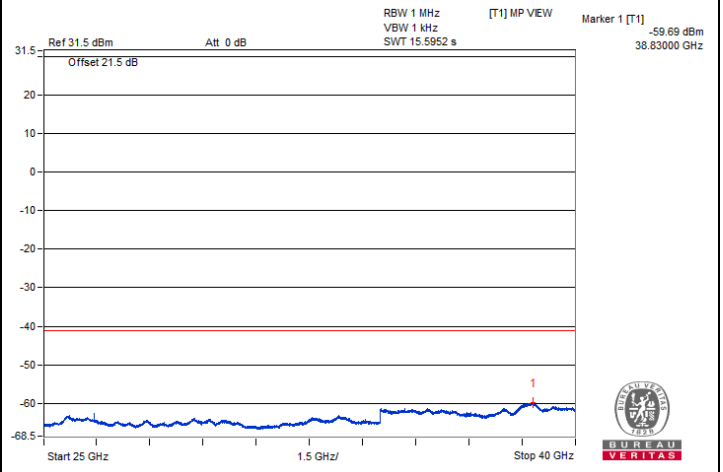
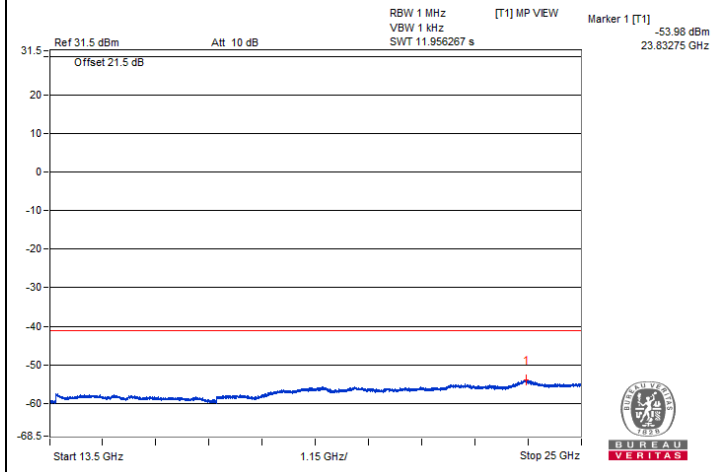
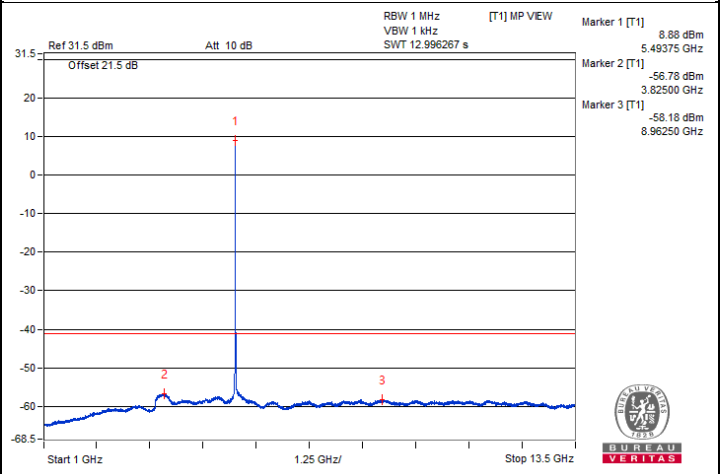
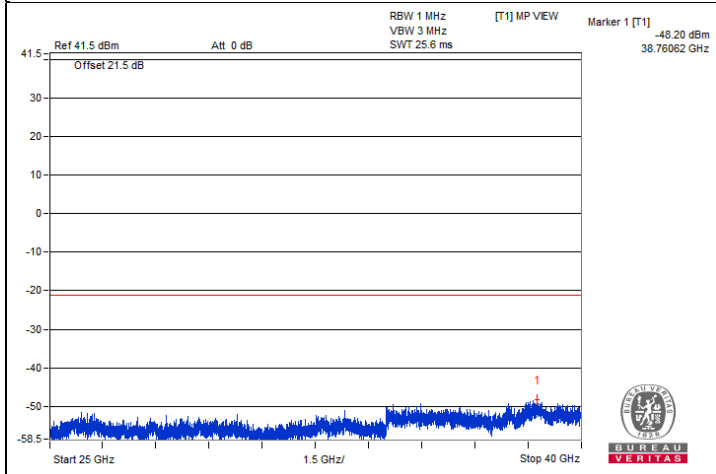
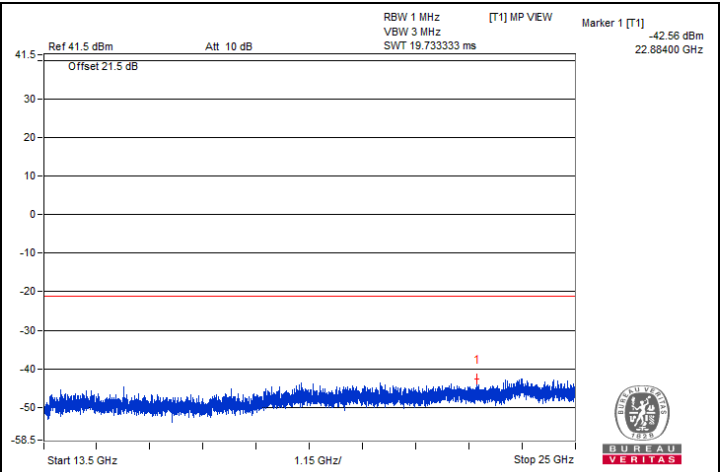
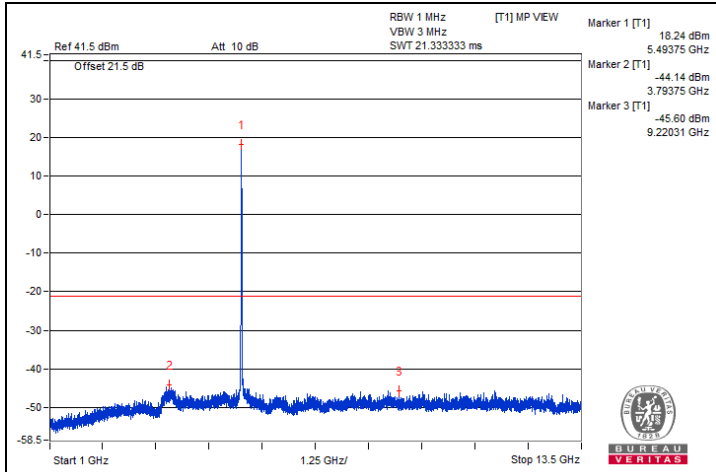

**Bandedge table**

No.	Frequency (MHz)	Emission Level (dBUV/m)	Limit (dBUV/m)	Margin (dB)	Raw Value (dBm)	Correction Factor (dB)	EIRP Level (dBm)
1	5458.5	62.92 PK	74	-11.08	-37.26	4.92	-32.34
2	5459.96	45.63 AV	54	-8.37	-54.55	4.92	-49.63
3	#5469	68.15 PK	68.2	-0.05	-32.03	4.92	-27.11

Remarks:

1. Margin value = Emission Level – Limit value
2. The other emission levels were very low against the limit.
3. " # " : The frequency is out of the restricted band.

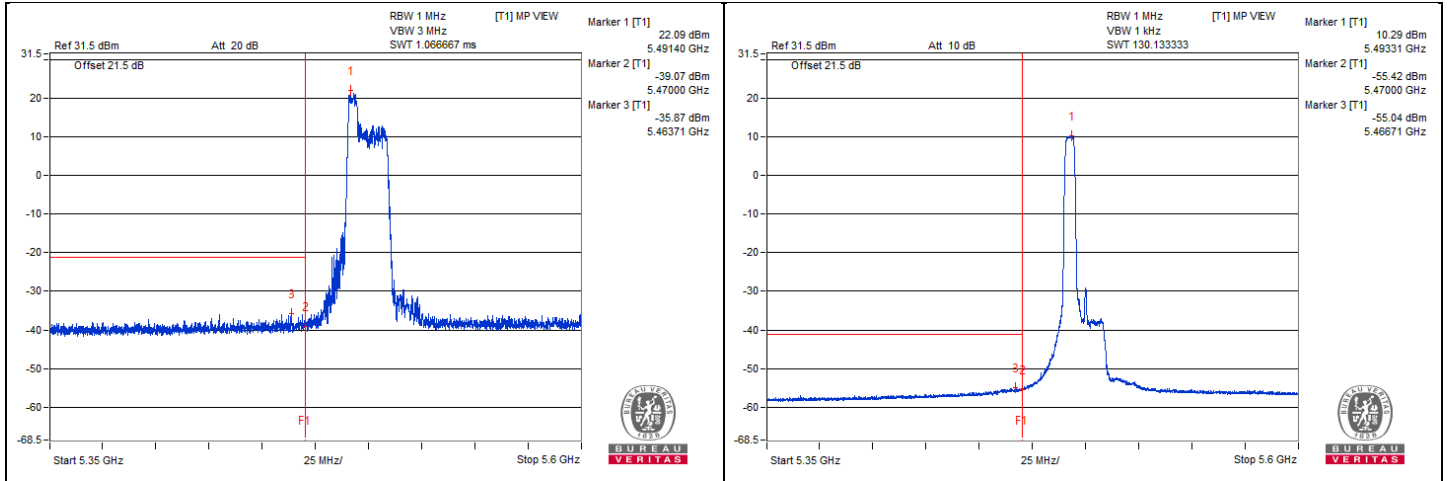

### 802.11be (EHT20) 106-tone RU - Channel 140

#### Conducted spurious emission table

No.	Frequency (MHz)	Emission Level (dBuV/m)	Limit (dBuV/m)	Margin (dB)	Raw Value (dBm)	Correction Factor (dB)	EIRP Level (dBm)
1	3801.56	54.9 PK	74	-19.1	-45.28	4.92	-40.36
2	3809.37	43.39 AV	54	-10.61	-56.79	4.92	-51.87
3	7614.06	52.65 PK	74	-21.35	-47.53	4.92	-42.61
4	7610.62	41.04 AV	54	-12.96	-59.14	4.92	-54.22
5	11405.93	53.32 PK	74	-20.68	-46.86	4.92	-41.94
6	11406.25	41.42 AV	54	-12.58	-58.76	4.92	-53.84
7	#17082.25	51.64 PK	68.2	-16.56	-48.54	4.92	-43.62

Remarks:

1. Margin value = Emission Level – Limit value
2. The other emission levels were very low against the limit.
3. " # " : The frequency is out of the restricted band.



BUREAU VERITAS

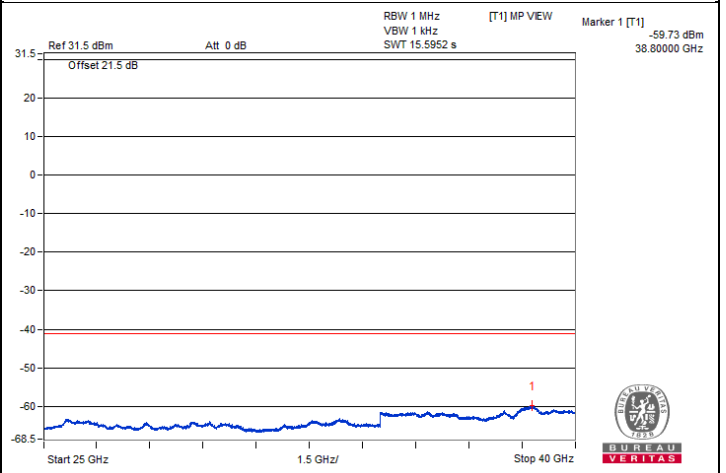
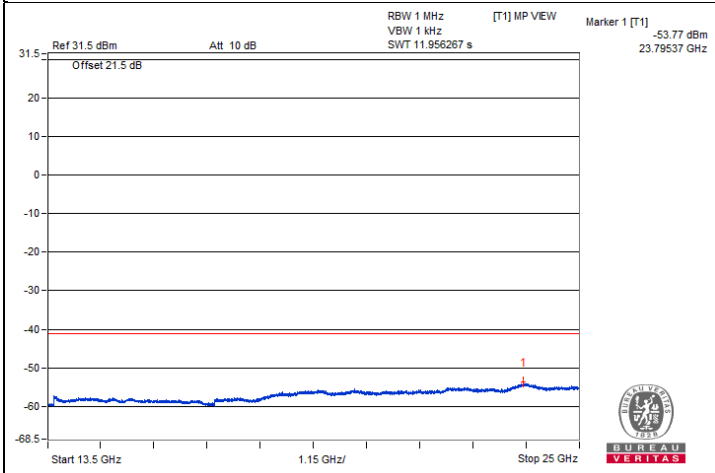
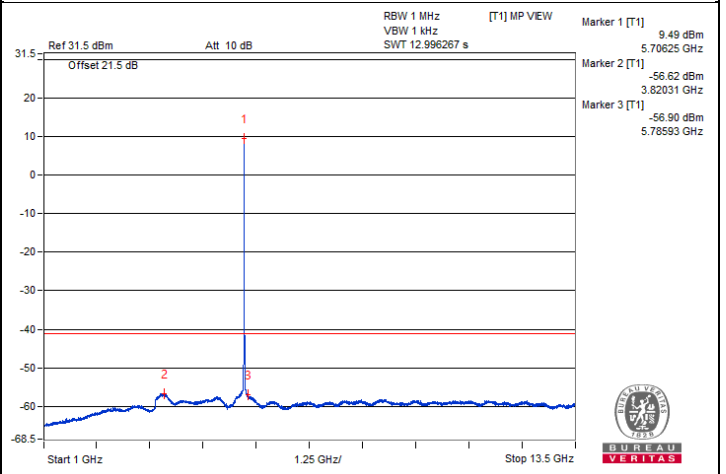
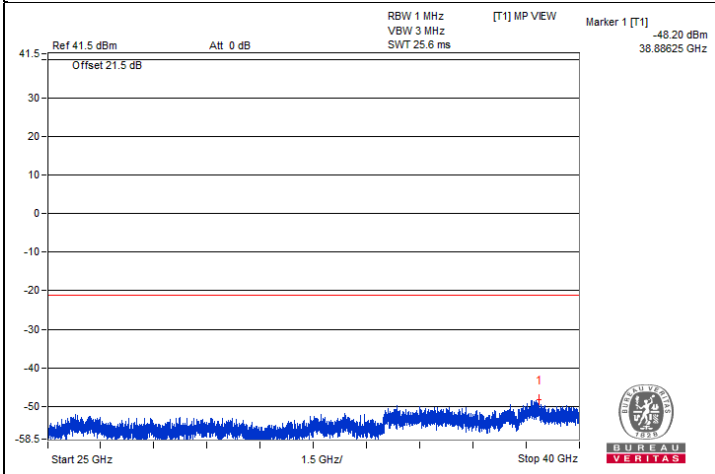
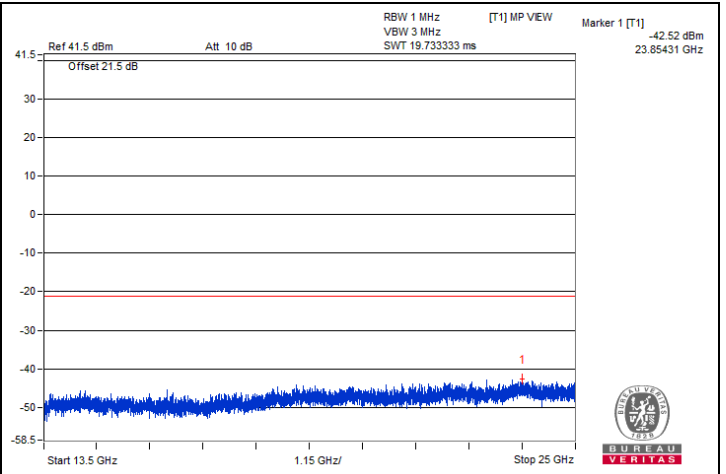
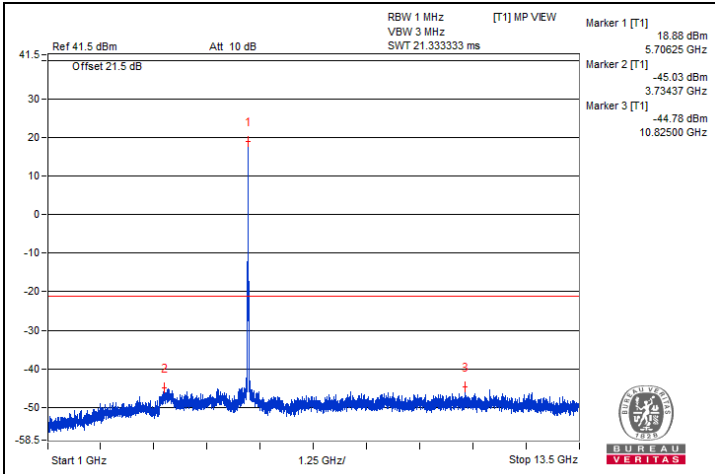

**Bandedge table**

No.	Frequency (MHz)	Emission Level (dBuV/m)	Limit (dBuV/m)	Margin (dB)	Raw Value (dBm)	Correction Factor (dB)	EIRP Level (dBm)
1	#5727.82	68.11 PK	68.2	-0.09	-32.07	4.92	-27.15

Remarks:

1. Margin value = Emission Level – Limit value
2. The other emission levels were very low against the limit.
3. " # " : The frequency is out of the restricted band.

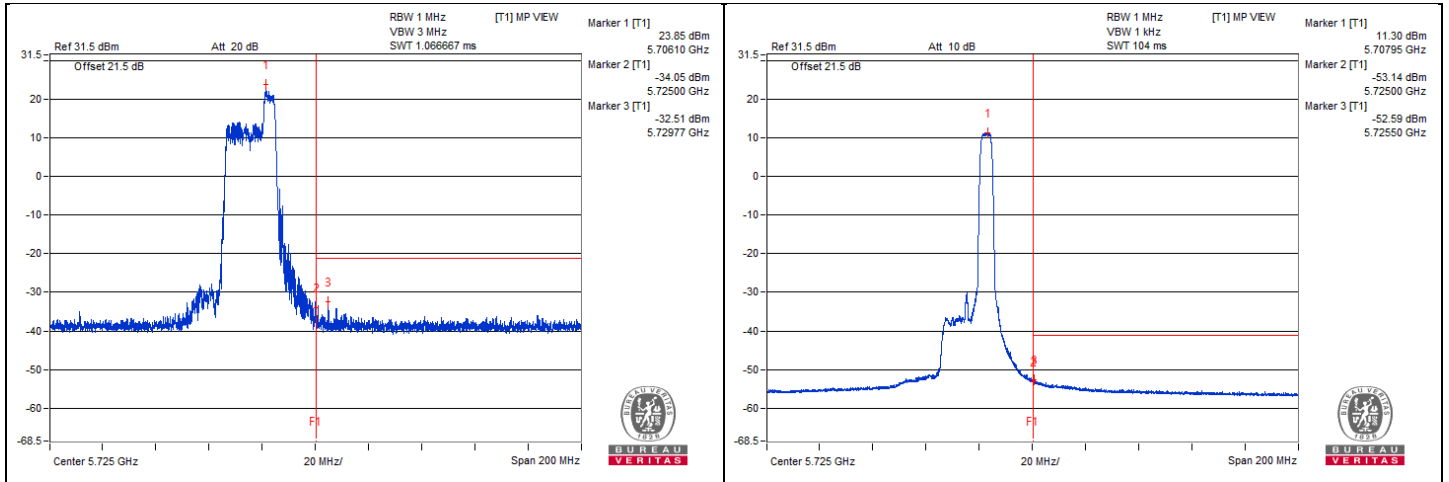

**802.11be (EHT20) 52+26-tone MRU - Channel 64**
**Conducted spurious emission table**

No.	Frequency (MHz)	Emission Level (dBuV/m)	Limit (dBuV/m)	Margin (dB)	Raw Value (dBm)	Correction Factor (dB)	EIRP Level (dBm)
1	3554.68	51.24 PK	74	-22.76	-48.94	4.92	-44.02
2	3562.5	39.6 AV	54	-14.4	-60.58	4.92	-55.66
3	#7084.37	52.07 PK	68.2	-16.13	-48.11	4.92	-43.19
4	10645.31	53.65 PK	74	-20.35	-46.53	4.92	-41.61
5	10650	41.5 AV	54	-12.5	-58.68	4.92	-53.76
6	15960.31	53.19 PK	74	-20.81	-46.99	4.92	-42.07
7	15952.37	41.68 AV	54	-12.32	-58.5	4.92	-53.58

**Remarks:**

1. Margin value = Emission Level – Limit value
2. The other emission levels were very low against the limit.
3. " # " : The frequency is out of the restricted band.



BUREAU VERITAS

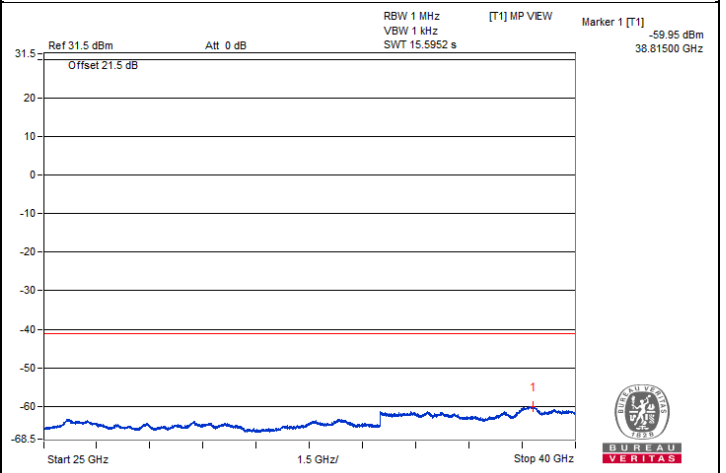
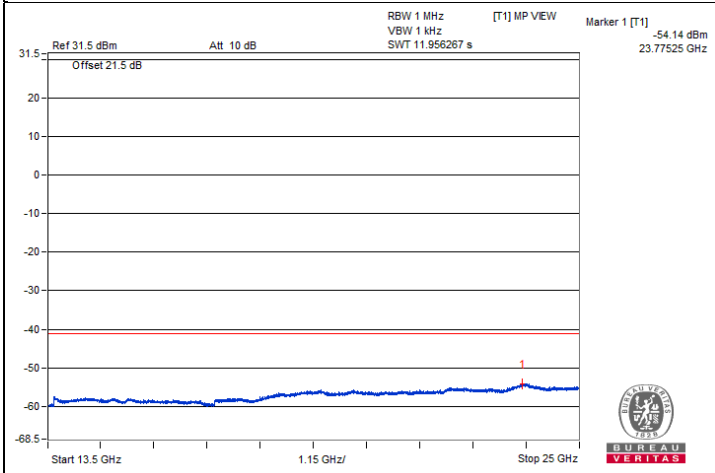
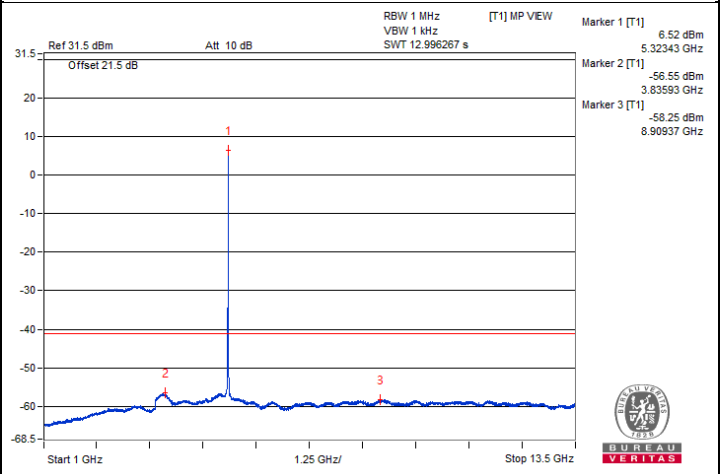
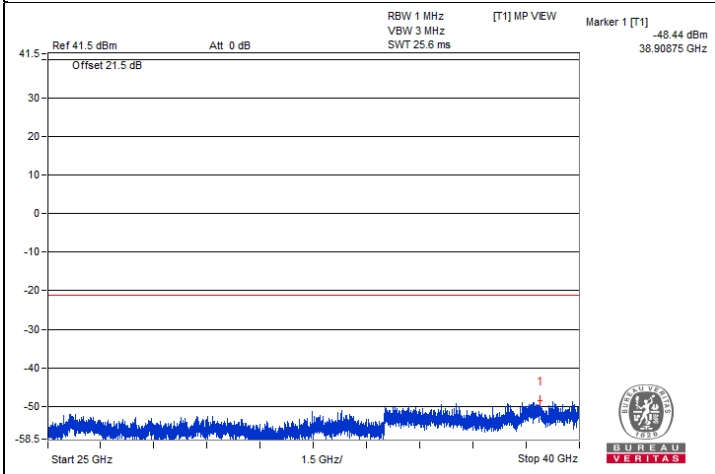
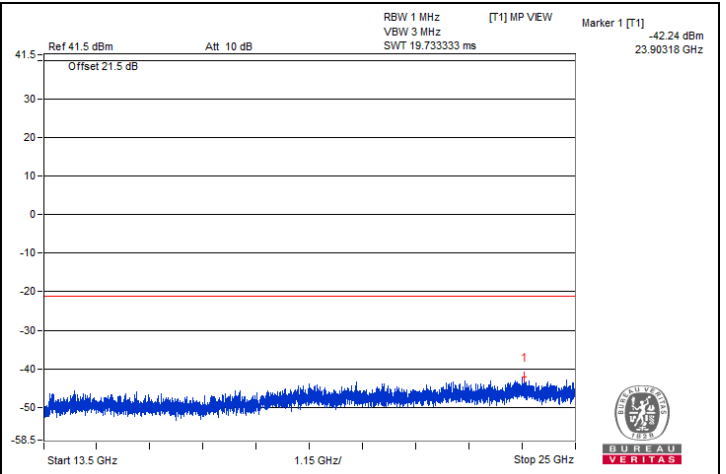
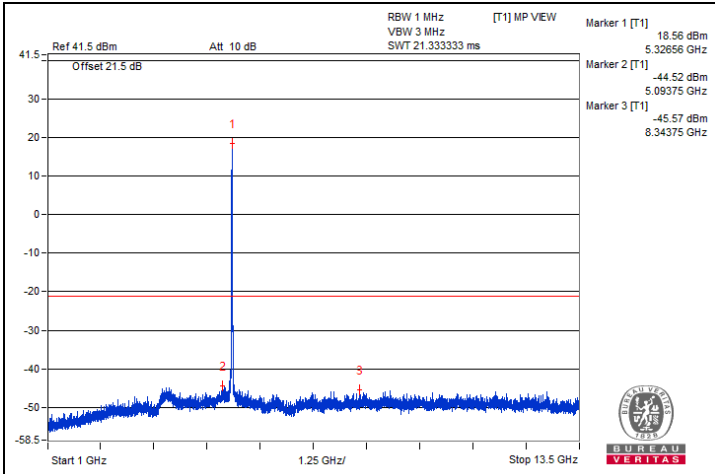

**Bandedge table**

No.	Frequency (MHz)	Emission Level (dBUV/m)	Limit (dBUV/m)	Margin (dB)	Raw Value (dBm)	Correction Factor (dB)	EIRP Level (dBm)
1	5361.85	63.68 PK	74	-10.32	-36.5	4.92	-31.58
2	5350.02	45.68 AV	54	-8.32	-54.5	4.92	-49.58

Remarks:

1. Margin value = Emission Level – Limit value
2. The other emission levels were very low against the limit.

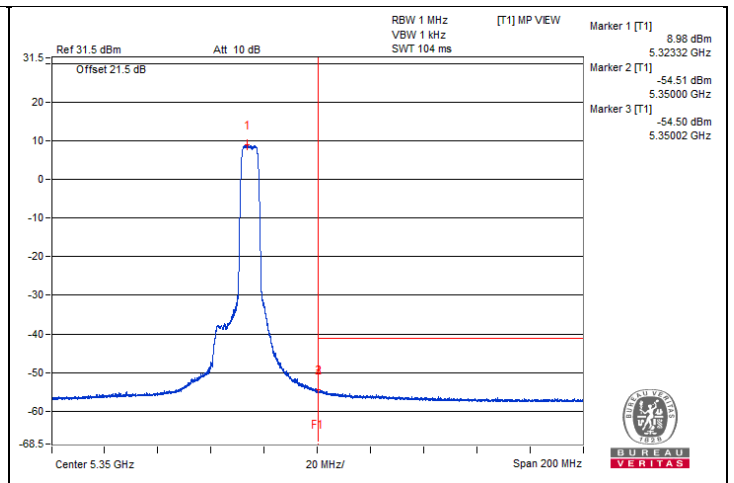
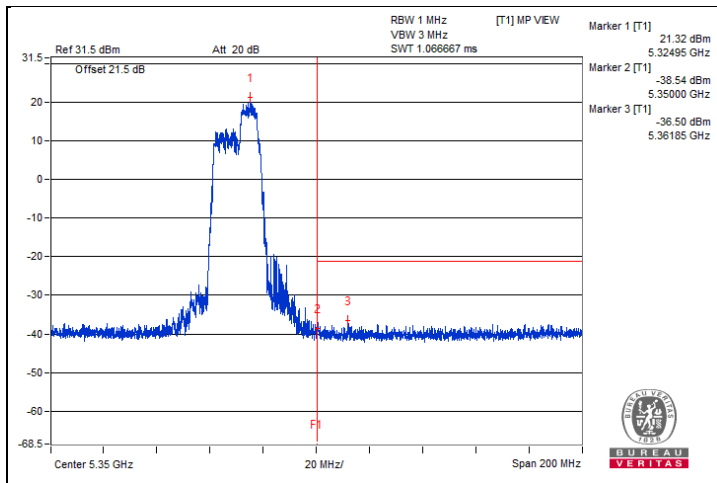



### 802.11be (EHT20) 52+26-tone MRU - Channel 100

#### Conducted spurious emission table

No.	Frequency (MHz)	Emission Level (dBuV/m)	Limit (dBuV/m)	Margin (dB)	Raw Value (dBm)	Correction Factor (dB)	EIRP Level (dBm)
1	3685.93	53.61 PK	74	-20.39	-46.57	4.92	-41.65
2	3684.37	42.9 AV	54	-11.1	-57.28	4.92	-52.36
3	7331.25	52.39 PK	74	-21.61	-47.79	4.92	-42.87
4	7317.18	40.99 AV	54	-13.01	-59.19	4.92	-54.27
5	11006.25	53.29 PK	74	-20.71	-46.89	4.92	-41.97
6	11009.37	41.49 AV	54	-12.51	-58.69	4.92	-53.77
7	#16508.68	52.28 PK	68.2	-15.92	-47.9	4.92	-42.98

Remarks:

1. Margin value = Emission Level – Limit value
2. The other emission levels were very low against the limit.
3. " # " : The frequency is out of the restricted band.



BUREAU VERITAS

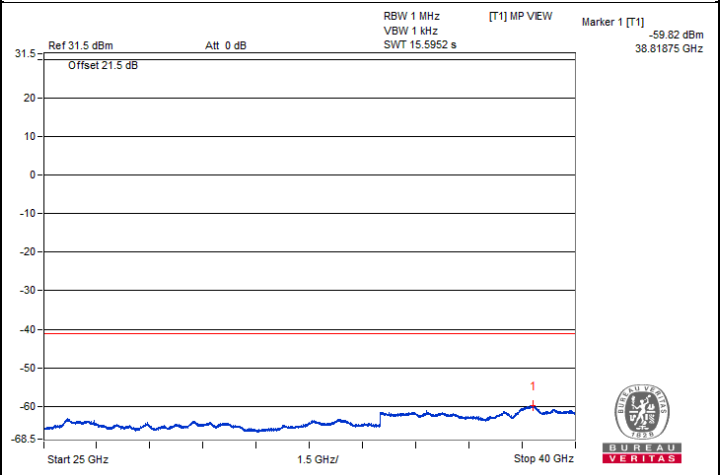
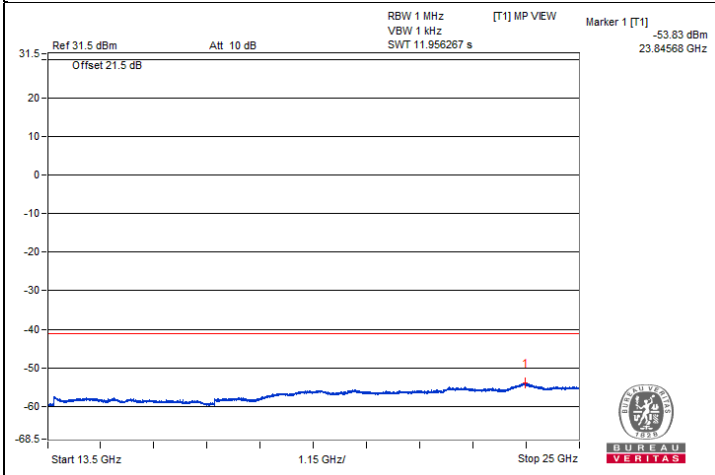
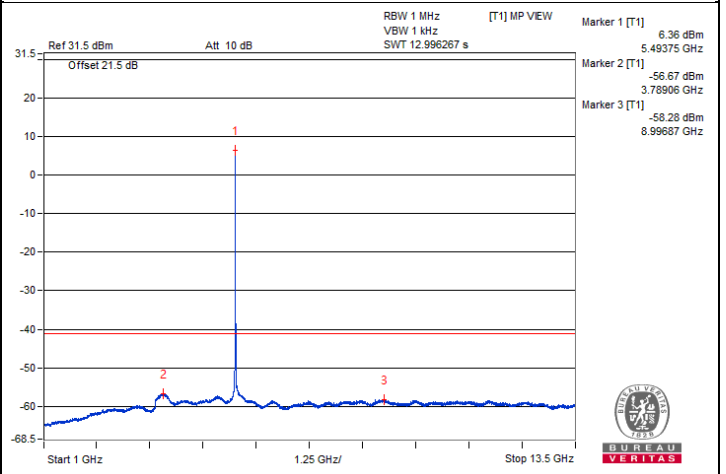
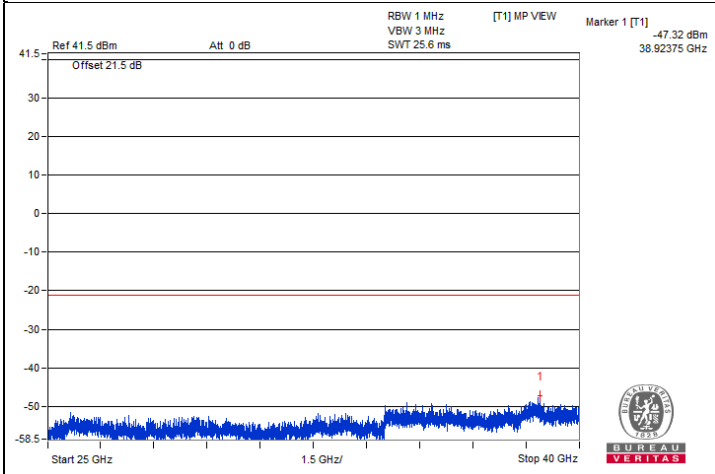
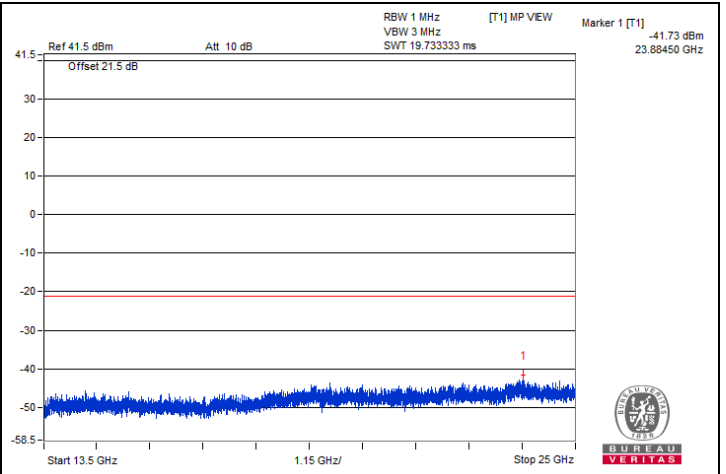
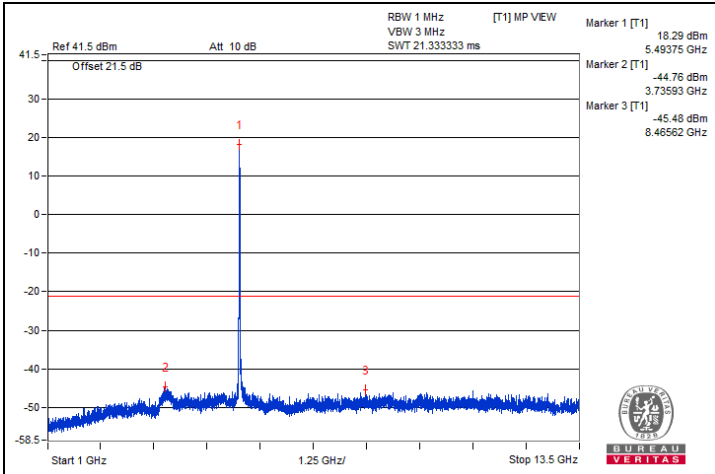

**Bandedge table**

No.	Frequency (MHz)	Emission Level (dBuV/m)	Limit (dBuV/m)	Margin (dB)	Raw Value (dBm)	Correction Factor (dB)	EIRP Level (dBm)
1	5368.65	63.05 PK	74	-10.95	-37.13	4.92	-32.21
2	5458.84	44.39 AV	54	-9.61	-55.79	4.92	-50.87
3	#5468.62	63.05 PK	68.2	-5.15	-37.13	4.92	-32.21

Remarks:

1. Margin value = Emission Level – Limit value
2. The other emission levels were very low against the limit.
3. " # " : The frequency is out of the restricted band.

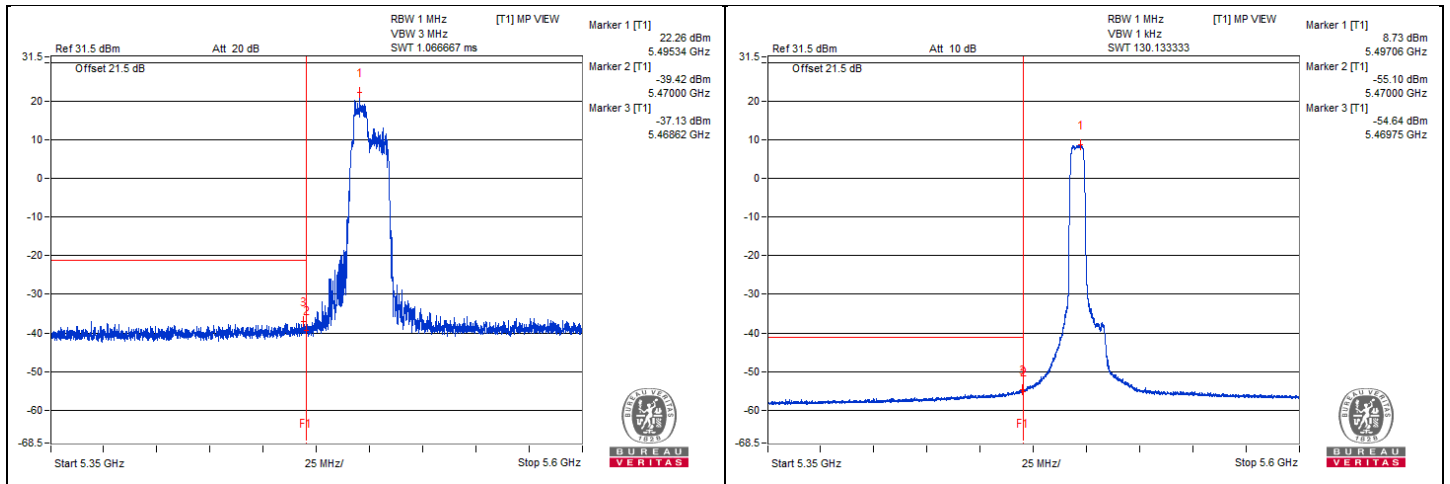

### 802.11be (EHT20) 52+26-tone MRU - Channel 140

#### Conducted spurious emission table

No.	Frequency (MHz)	Emission Level (dBuV/m)	Limit (dBuV/m)	Margin (dB)	Raw Value (dBm)	Correction Factor (dB)	EIRP Level (dBm)
1	3784.37	56.25 PK	74	-17.75	-43.93	4.92	-39.01
2	3782.81	43.48 AV	54	-10.52	-56.7	4.92	-51.78
3	7610.93	52.28 PK	74	-21.72	-47.9	4.92	-42.98
4	7609.37	40.88 AV	54	-13.12	-59.3	4.92	-54.38
5	11406.5	53.26 PK	74	-20.74	-46.92	4.92	-42.00
6	11406.25	41.27 AV	54	-12.73	-58.91	4.92	-53.99
7	#17116.75	51.82 PK	68.2	-16.38	-48.36	4.92	-43.44

Remarks:

1. Margin value = Emission Level – Limit value
2. The other emission levels were very low against the limit.
3. " # " : The frequency is out of the restricted band.



BUREAU  
VERITAS

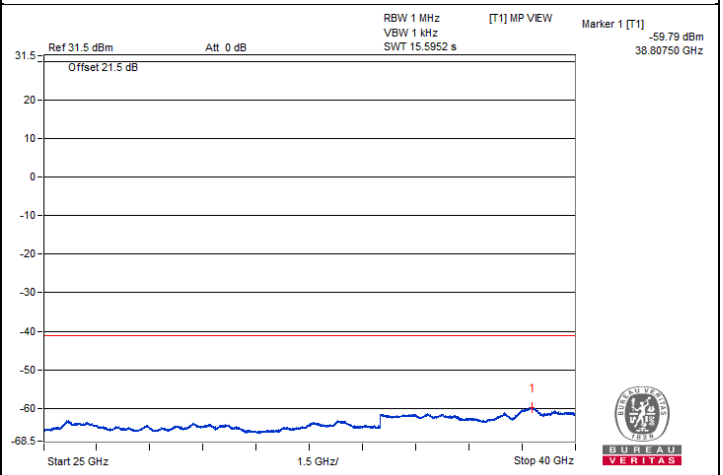
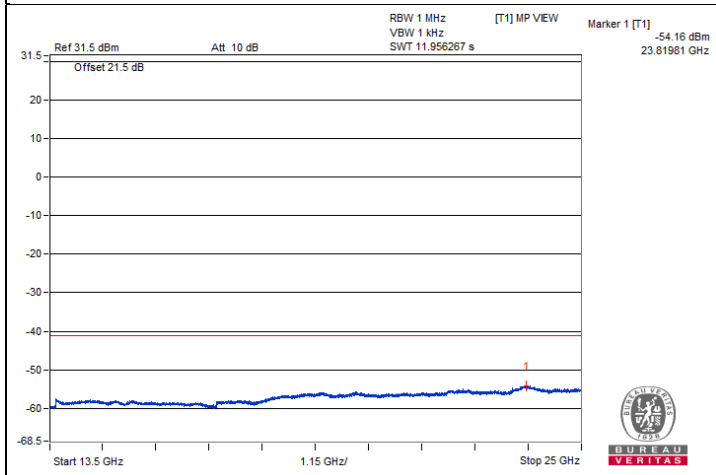
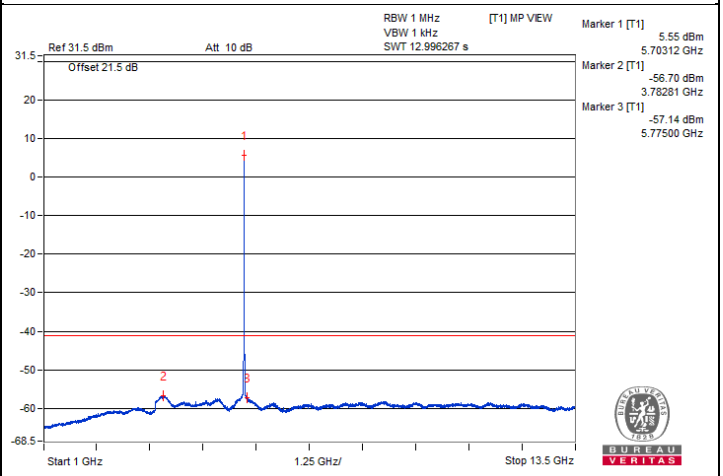
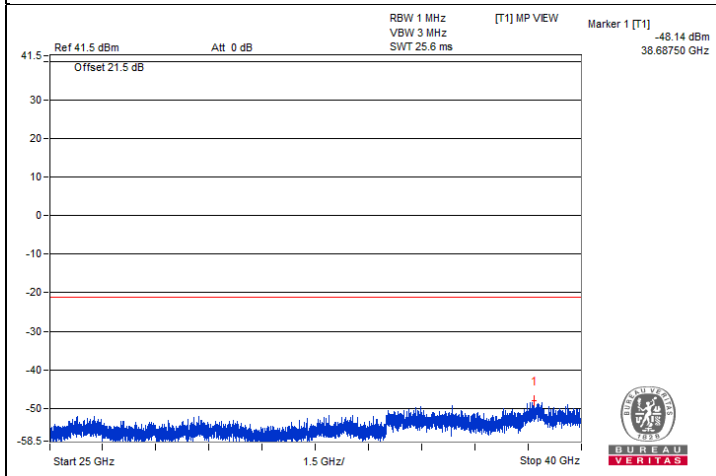
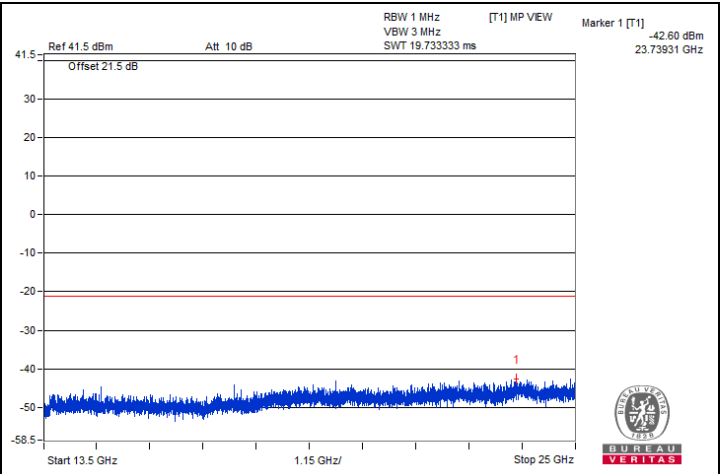
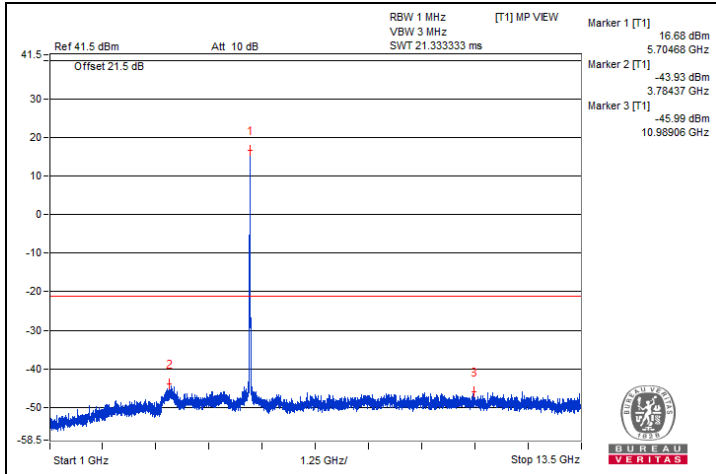

### Bandedge table

No.	Frequency (MHz)	Emission Level (dBuV/m)	Limit (dBuV/m)	Margin (dB)	Raw Value (dBm)	Correction Factor (dB)	EIRP Level (dBm)
1	#5731.45	65.72 PK	68.2	-2.48	-34.46	4.92	-29.54

Remarks:

1. Margin value = Emission Level – Limit value
2. The other emission levels were very low against the limit.
3. " # " : The frequency is out of the restricted band.

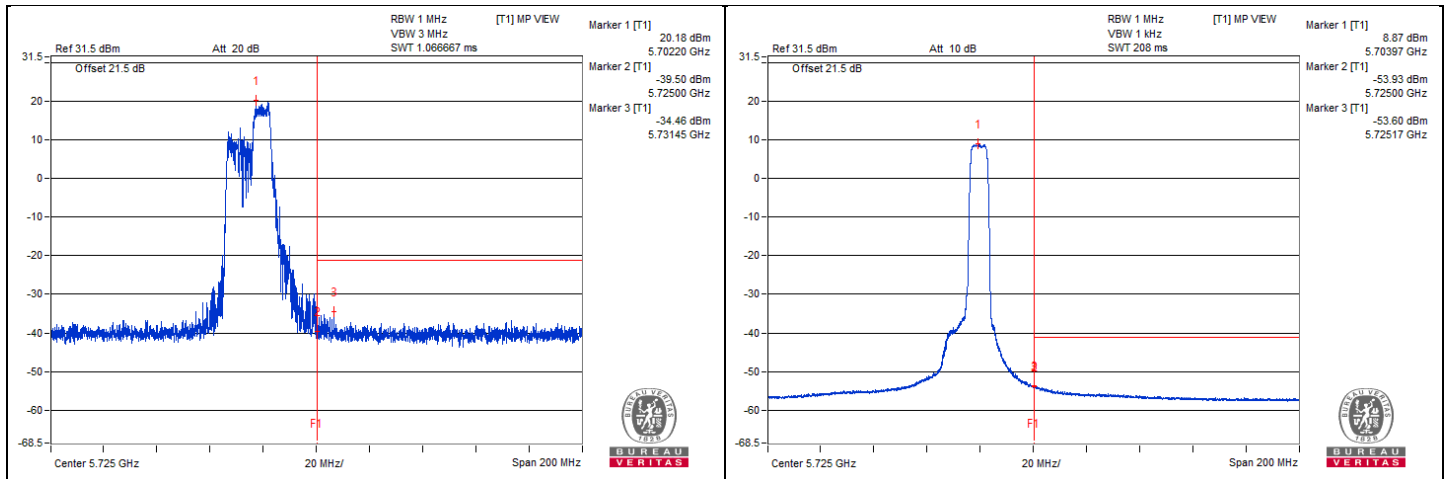

**802.11be (EHT20) 106+26-tone MRU - Channel 64**
**Conducted spurious emission table**

No.	Frequency (MHz)	Emission Level (dBuV/m)	Limit (dBuV/m)	Margin (dB)	Raw Value (dBm)	Correction Factor (dB)	EIRP Level (dBm)
1	3535.93	50.33 PK	74	-23.67	-49.85	4.92	-44.93
2	3551.56	39.37 AV	54	-14.63	-60.81	4.92	-55.89
3	#7081.25	52.15 PK	68.2	-16.05	-48.03	4.92	-43.11
4	10631.25	53.29 PK	74	-20.71	-46.89	4.92	-41.97
5	10623.43	41.24 AV	54	-12.76	-58.94	4.92	-54.02
6	15959.56	51.86 PK	74	-22.14	-48.32	4.92	-43.40
7	15959.56	41.83 AV	54	-12.17	-58.35	4.92	-53.43

**Remarks:**

1. Margin value = Emission Level – Limit value
2. The other emission levels were very low against the limit.
3. " # " : The frequency is out of the restricted band.



BUREAU  
VERITAS

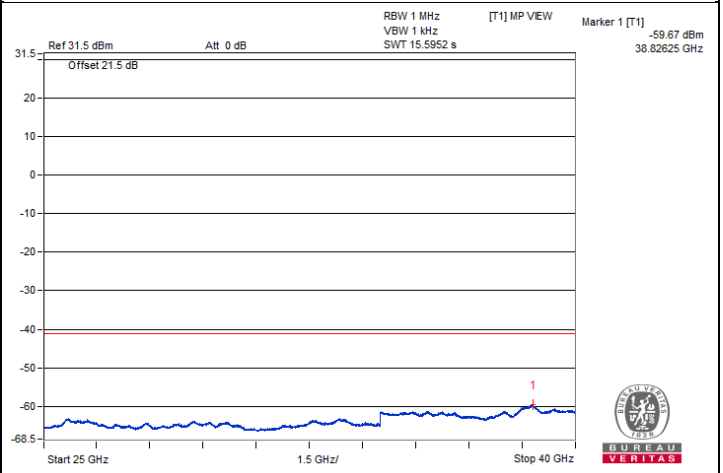
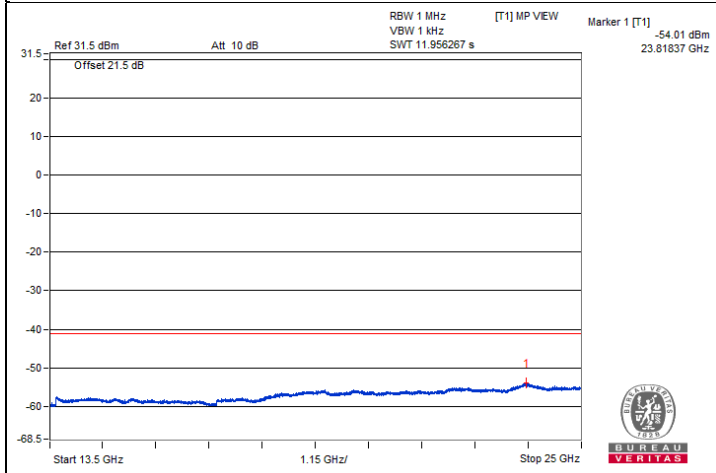
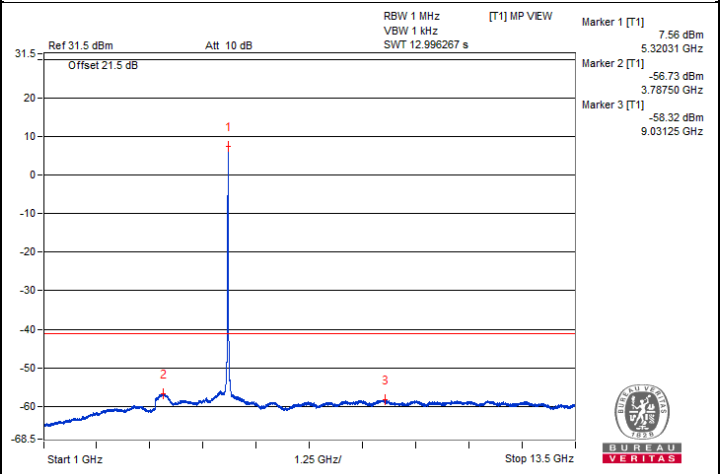
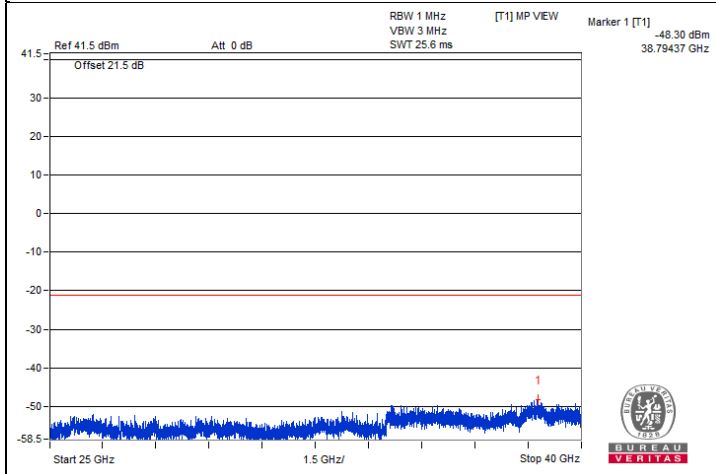
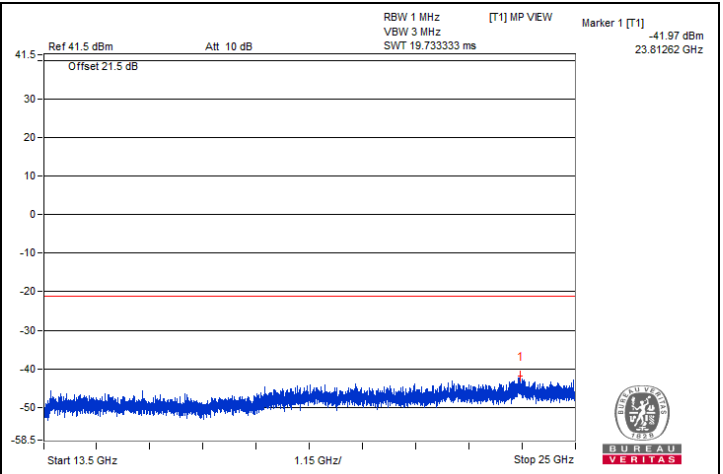
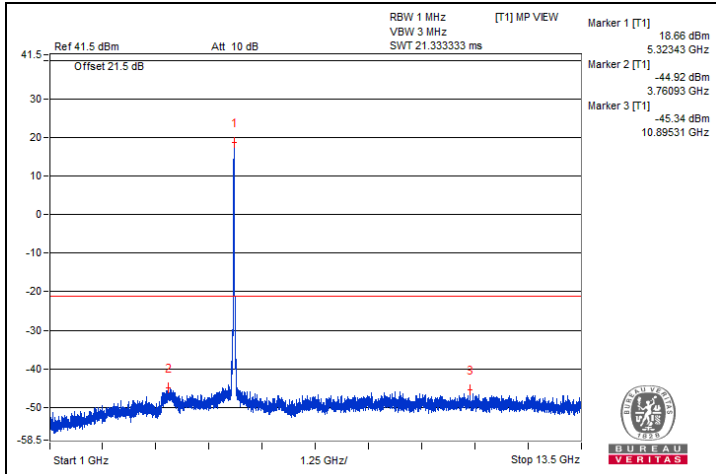



**Bandedge table**

No.	Frequency (MHz)	Emission Level (dBuV/m)	Limit (dBuV/m)	Margin (dB)	Raw Value (dBm)	Correction Factor (dB)	EIRP Level (dBm)
1	5350.77	69.96 PK	74	-4.04	-30.22	4.92	-25.30
2	5350.3	50.67 AV	54	-3.33	-49.51	4.92	-44.59

Remarks:

1. Margin value = Emission Level – Limit value
2. The other emission levels were very low against the limit.

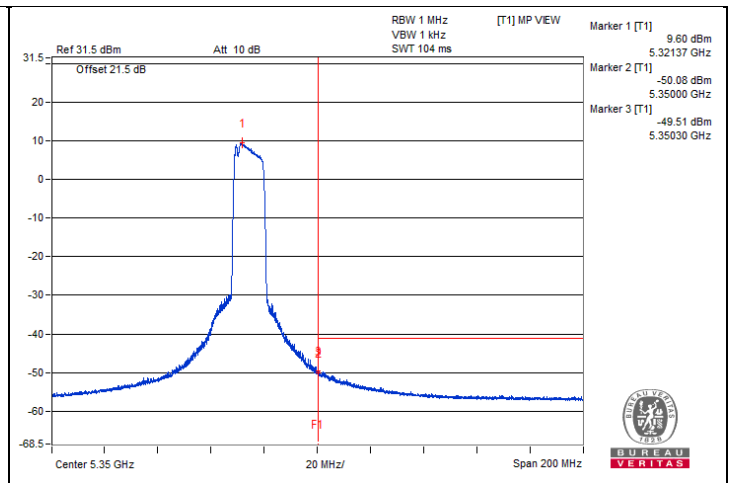
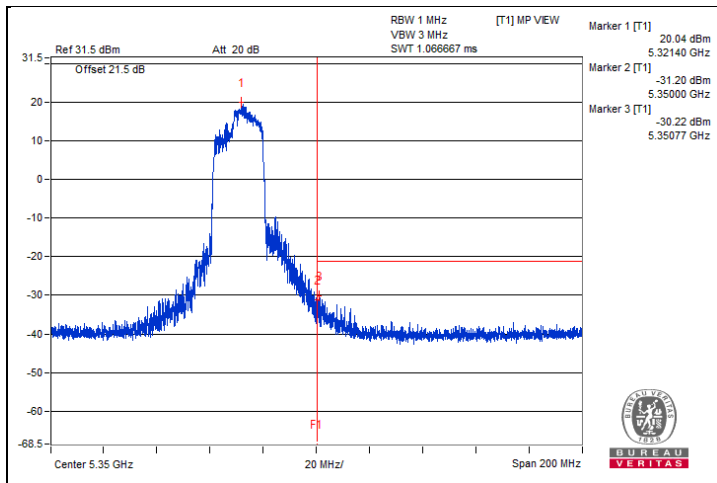

**802.11be (EHT20) 106+26-tone MRU - Channel 100**
**Conducted spurious emission table**

No.	Frequency (MHz)	Emission Level (dBuV/m)	Limit (dBuV/m)	Margin (dB)	Raw Value (dBm)	Correction Factor (dB)	EIRP Level (dBm)
1	3684.06	55.25 PK	74	-18.75	-44.93	4.92	-40.01
2	3684.37	42.67 AV	54	-11.33	-57.51	4.92	-52.59
3	7331.25	52.59 PK	74	-21.41	-47.59	4.92	-42.67
4	7331.06	40.8 AV	54	-13.2	-59.38	4.92	-54.46
5	11001.56	52.59 PK	74	-21.41	-47.59	4.92	-42.67
6	11009.37	41.54 AV	54	-12.46	-58.64	4.92	-53.72
7	#16497.18	51.91 PK	68.2	-16.29	-48.27	4.92	-43.35

**Remarks:**

1. Margin value = Emission Level – Limit value
2. The other emission levels were very low against the limit.
3. " # " : The frequency is out of the restricted band.



BUREAU  
VERITAS

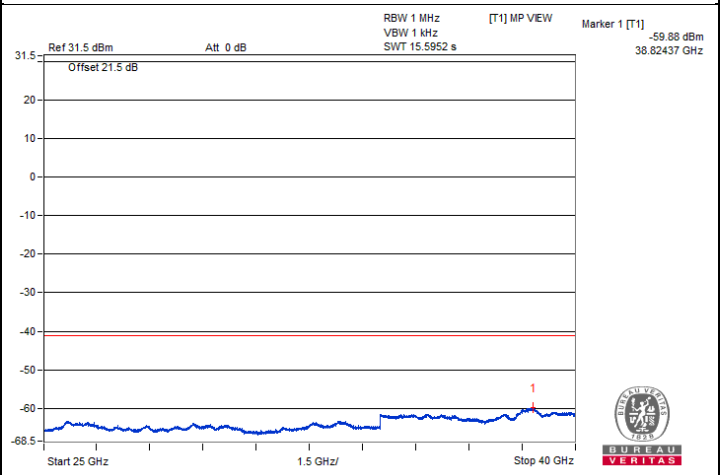
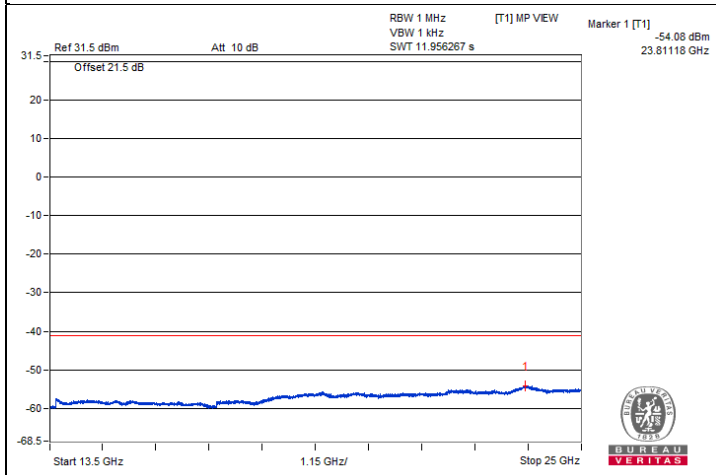
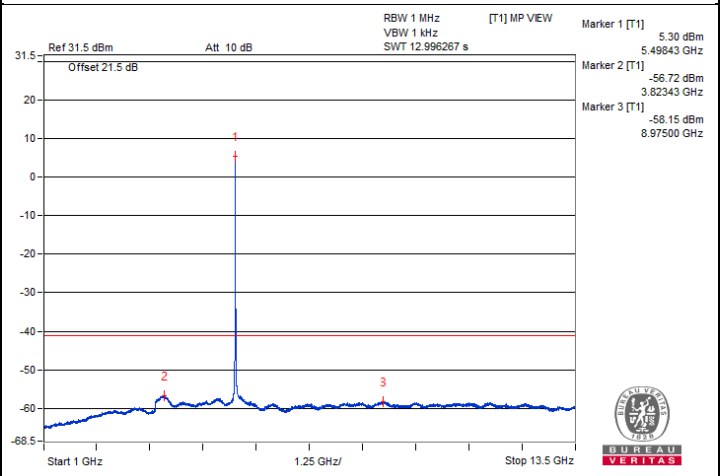
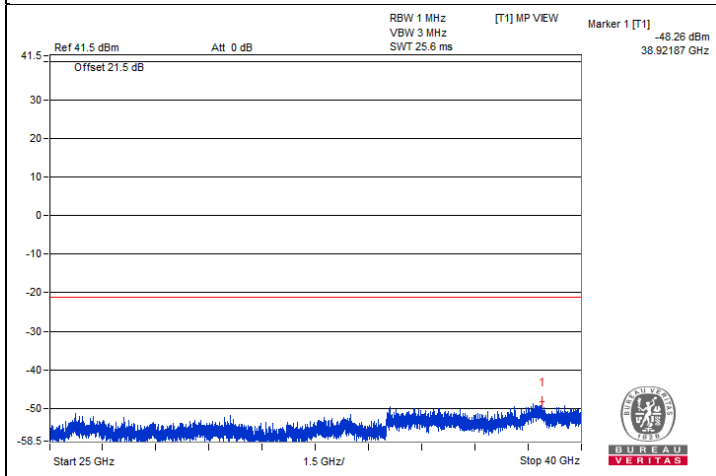
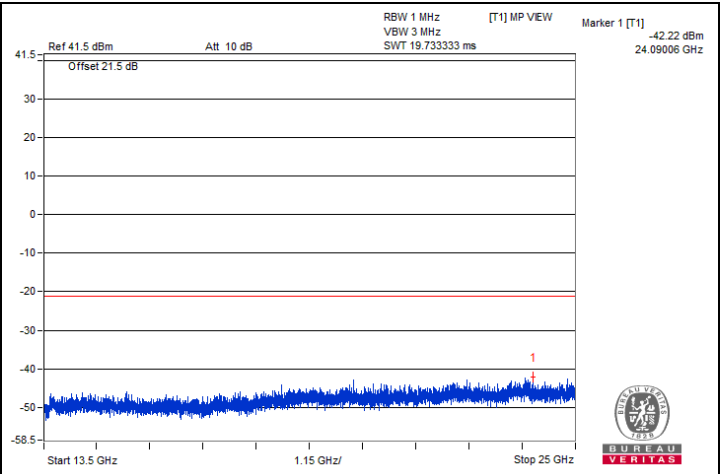
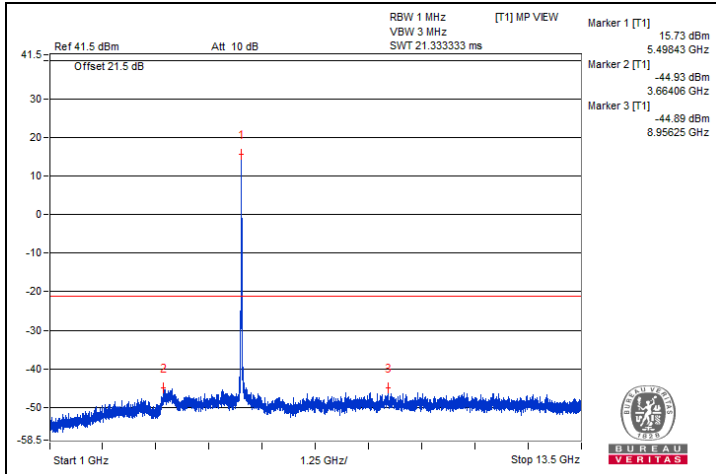

**Bandedge table**

No.	Frequency (MHz)	Emission Level (dBUV/m)	Limit (dBUV/m)	Margin (dB)	Raw Value (dBm)	Correction Factor (dB)	EIRP Level (dBm)
1	5455.75	65.31 PK	74	-8.69	-34.87	4.92	-29.95
2	5457.96	45.53 AV	54	-8.47	-54.65	4.92	-49.73
3	#5469.68	67.85 PK	68.2	-0.35	-32.33	4.92	-27.41

Remarks:

1. Margin value = Emission Level – Limit value
2. The other emission levels were very low against the limit.
3. " # " : The frequency is out of the restricted band.

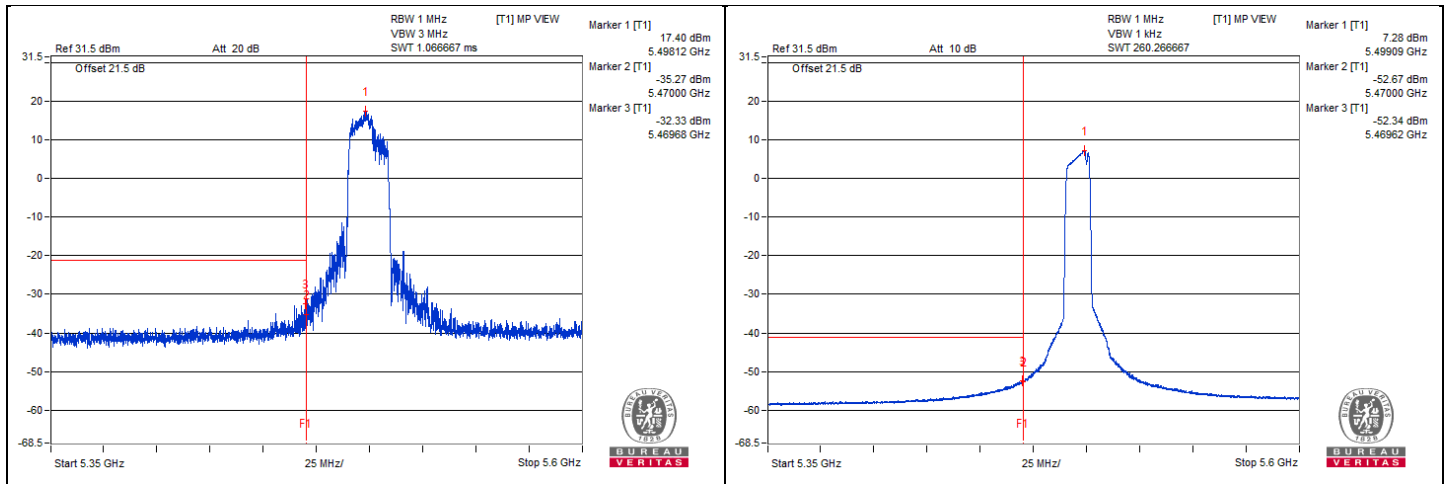

**802.11be (EHT20) 106+26-tone MRU - Channel 140**
**Conducted spurious emission table**

No.	Frequency (MHz)	Emission Level (dBuV/m)	Limit (dBuV/m)	Margin (dB)	Raw Value (dBm)	Correction Factor (dB)	EIRP Level (dBm)
1	3803.12	54.36 PK	74	-19.64	-45.82	4.92	-40.90
2	3792.18	43.49 AV	54	-10.51	-56.69	4.92	-51.77
3	7610.93	52.83 PK	74	-21.17	-47.35	4.92	-42.43
4	7612.5	40.84 AV	54	-13.16	-59.34	4.92	-54.42
5	11400	52.42 PK	74	-21.58	-47.76	4.92	-42.84
6	11406.25	41.44 AV	54	-12.56	-58.74	4.92	-53.82
7	#17100.93	52.31 PK	68.2	-15.89	-47.87	4.92	-42.95

**Remarks:**

1. Margin value = Emission Level – Limit value
2. The other emission levels were very low against the limit.
3. " # " : The frequency is out of the restricted band.

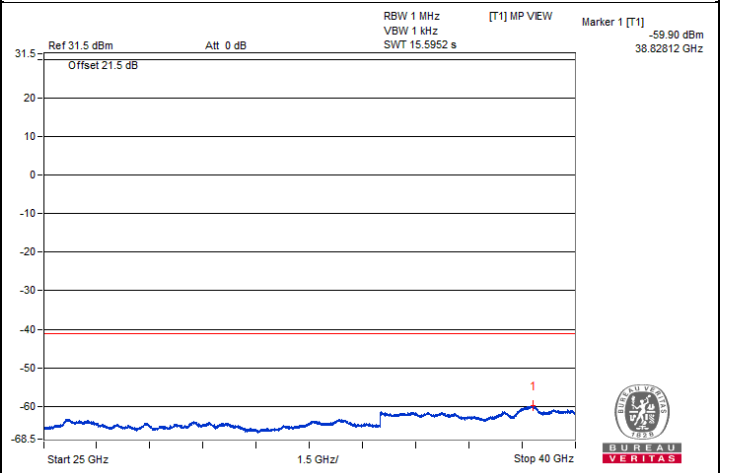
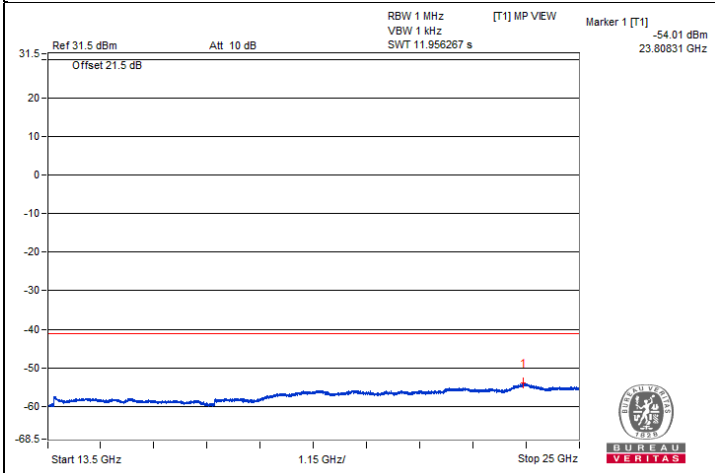
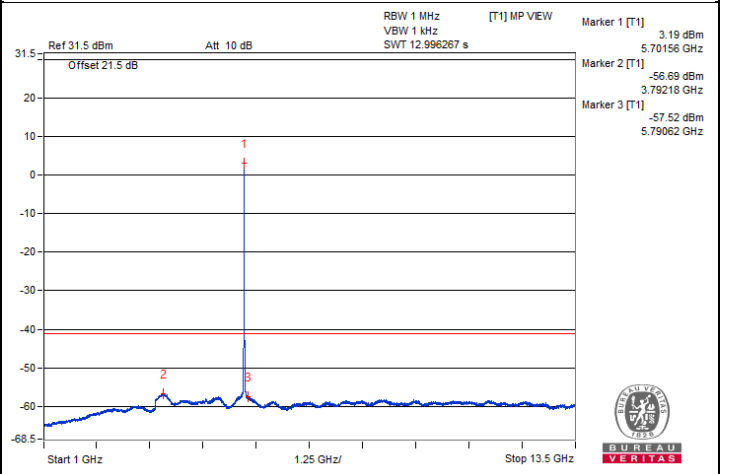
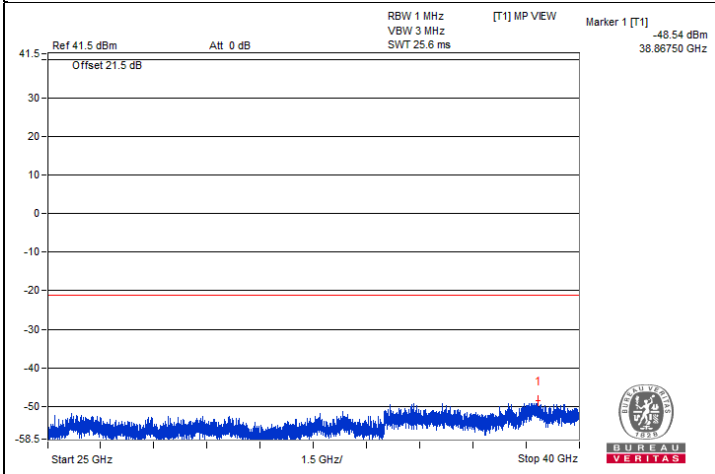
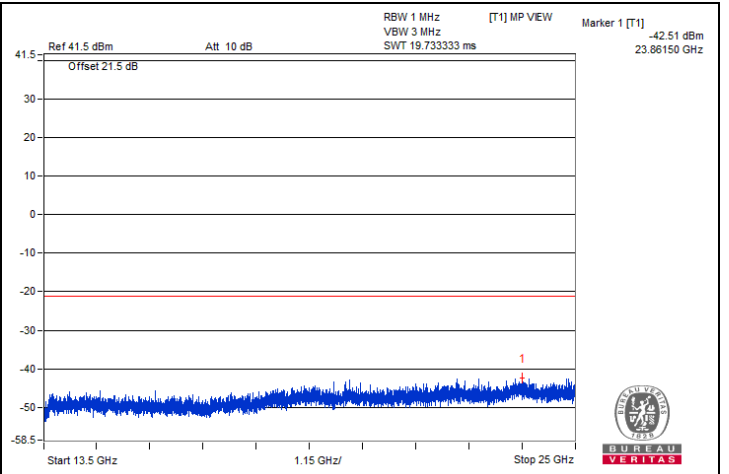
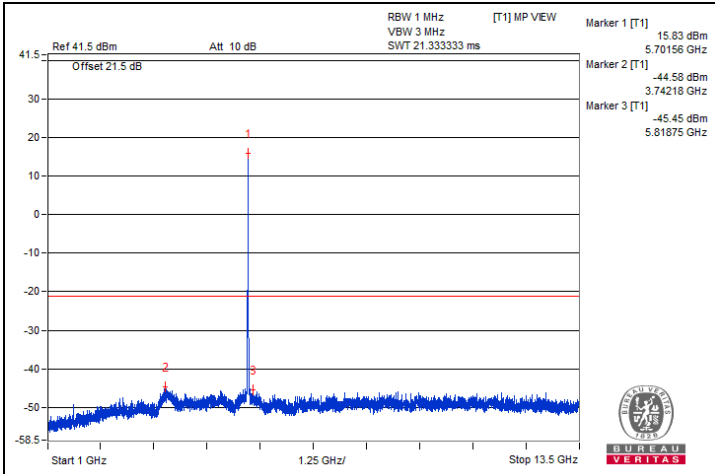

**Bandedge table**

No.	Frequency (MHz)	Emission Level (dBuV/m)	Limit (dBuV/m)	Margin (dB)	Raw Value (dBm)	Correction Factor (dB)	EIRP Level (dBm)
1	#5725.32	67.04 PK	68.2	-1.16	-33.14	4.92	-28.22

Remarks:

1. Margin value = Emission Level – Limit value
2. The other emission levels were very low against the limit.
3. " # " : The frequency is out of the restricted band.

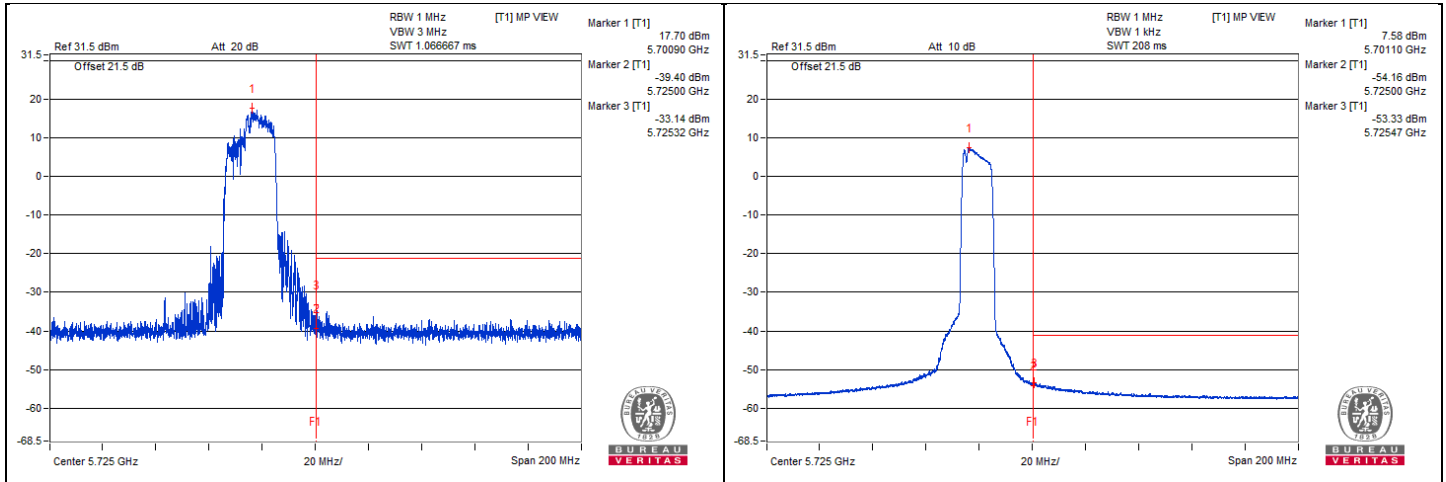

### 802.11be (EHT80) 484+242-tone MRU - Channel 58

#### Conducted spurious emission table

No.	Frequency (MHz)	Emission Level (dBuV/m)	Limit (dBuV/m)	Margin (dB)	Raw Value (dBm)	Correction Factor (dB)	EIRP Level (dBm)
1	3520.31	50 PK	74	-24	-50.18	4.92	-45.26
2	3535.93	39.45 AV	54	-14.55	-60.73	4.92	-55.81
3	#7042.18	53.17 PK	68.2	-15.03	-47.01	4.92	-42.09
4	#10598.43	53.29 PK	68.2	-14.91	-46.89	4.92	-41.97
5	15874.75	52.97 PK	74	-21.03	-47.21	4.92	-42.29
6	15864.68	41.59 AV	54	-12.41	-58.59	4.92	-53.67

Remarks:

1. Margin value = Emission Level – Limit value
2. The other emission levels were very low against the limit.
3. " # " : The frequency is out of the restricted band.





BUREAU  
VERITAS

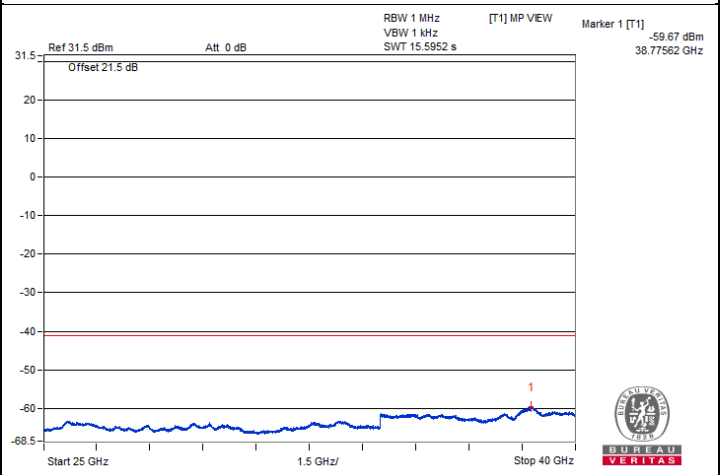
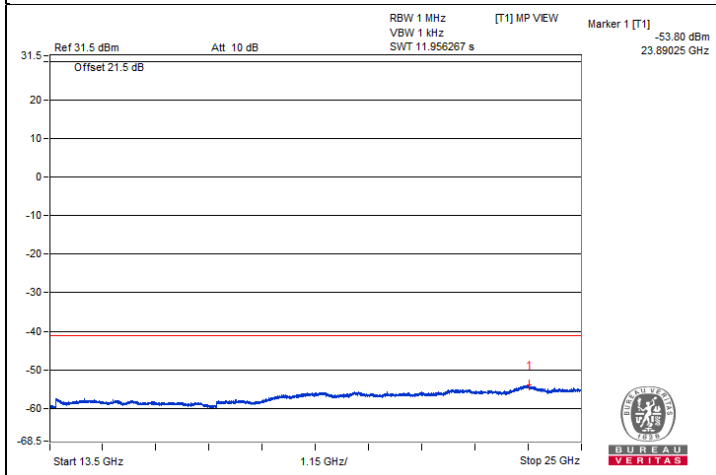
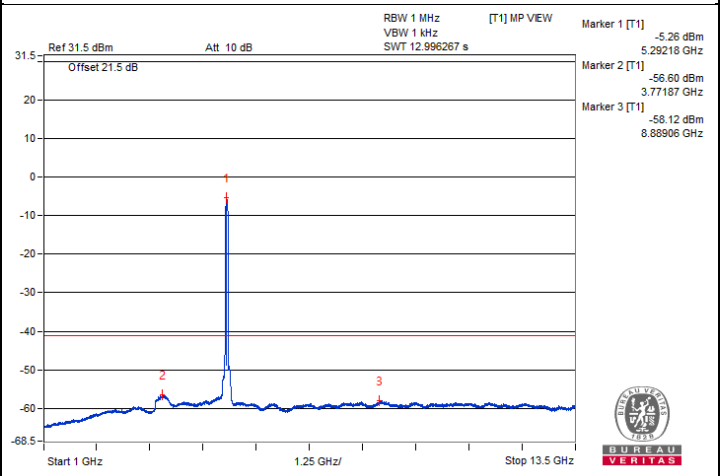
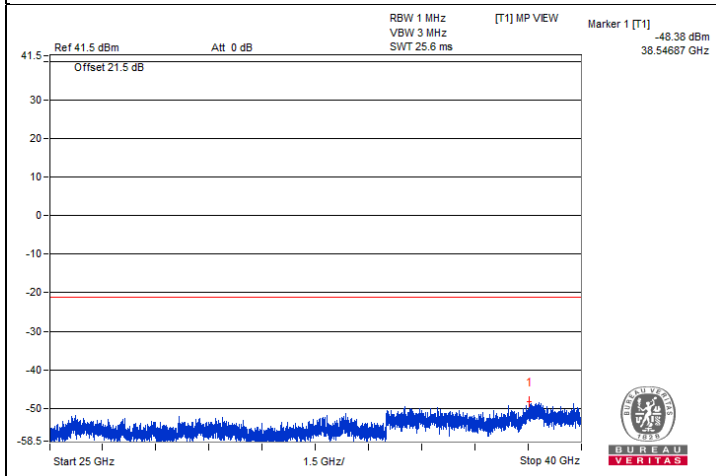
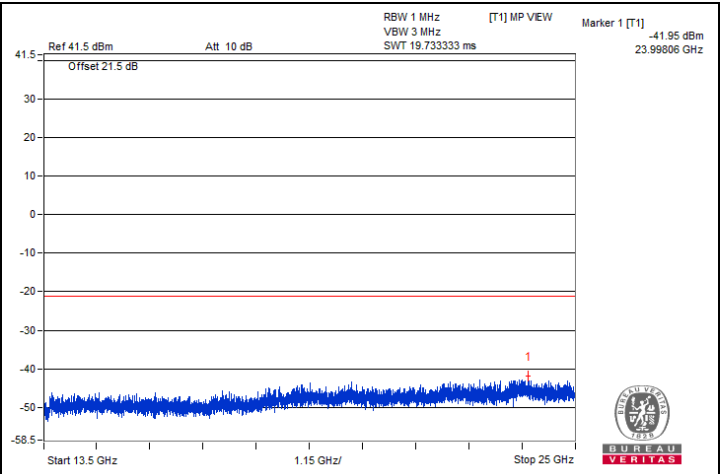
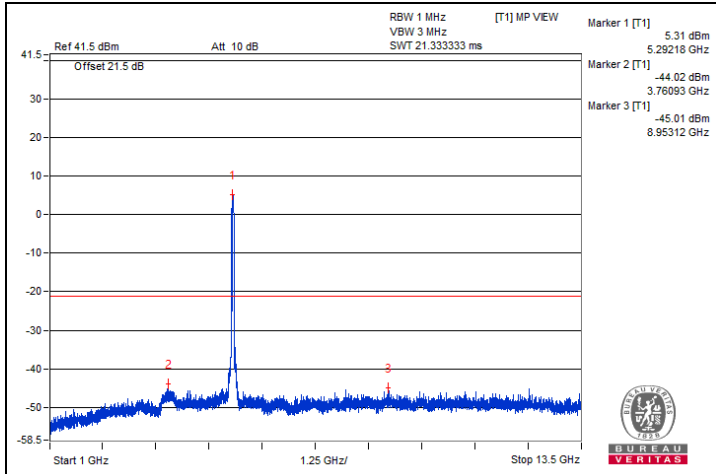

**Bandedge table**

No.	Frequency (MHz)	Emission Level (dBuV/m)	Limit (dBuV/m)	Margin (dB)	Raw Value (dBm)	Correction Factor (dB)	EIRP Level (dBm)
1	5361.17	72.42 PK	74	-1.58	-27.76	4.92	-22.84
2	5358.52	52.74 AV	54	-1.26	-47.44	4.92	-42.52

Remarks:

1. Margin value = Emission Level – Limit value
2. The other emission levels were very low against the limit.

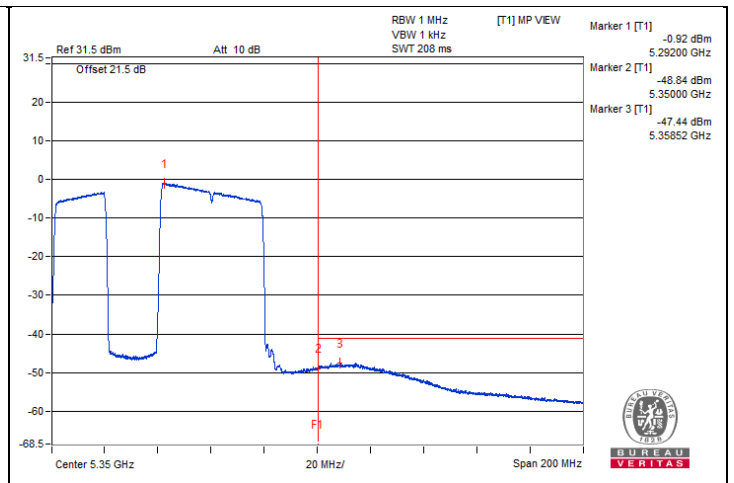
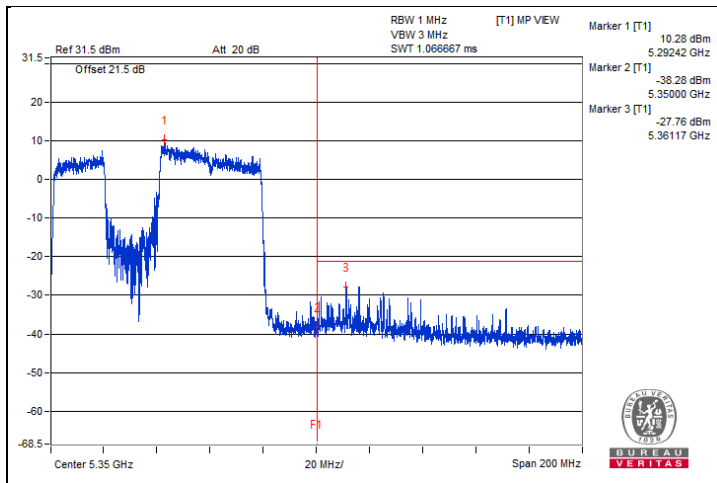

### 802.11be (EHT80) 484+242-tone MRU - Channel 106

#### Conducted spurious emission table

No.	Frequency (MHz)	Emission Level (dBuV/m)	Limit (dBuV/m)	Margin (dB)	Raw Value (dBm)	Correction Factor (dB)	EIRP Level (dBm)
1	3701.56	55.54 PK	74	-18.46	-44.64	4.92	-39.72
2	3701.93	43.03 AV	54	-10.97	-57.15	4.92	-52.23
3	7356.25	53.04 PK	74	-20.96	-47.14	4.92	-42.22
4	7360.93	40.63 AV	54	-13.37	-59.55	4.92	-54.63
5	11059.37	53.13 PK	74	-20.87	-47.05	4.92	-42.13
6	11057.81	41.43 AV	54	-12.57	-58.75	4.92	-53.83
7	#16573.37	51.96 PK	68.2	-16.24	-48.22	4.92	-43.30

Remarks:

1. Margin value = Emission Level – Limit value
2. The other emission levels were very low against the limit.
3. " # " : The frequency is out of the restricted band.



BUREAU  
VERITAS

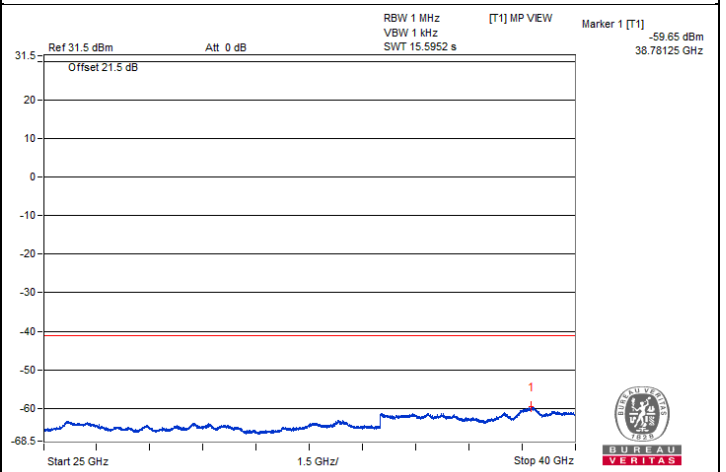
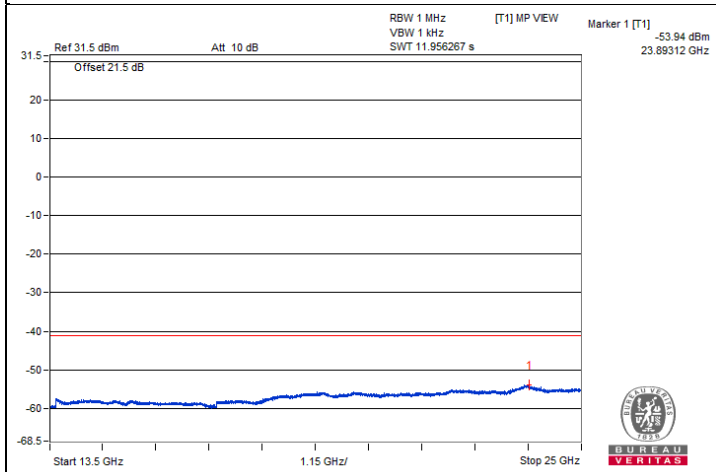
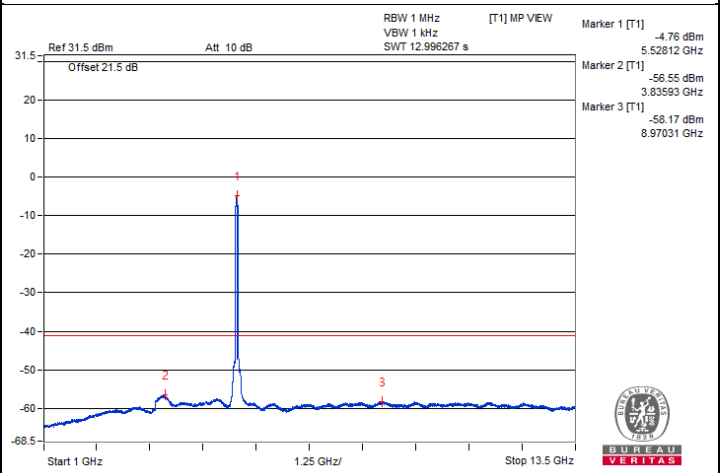
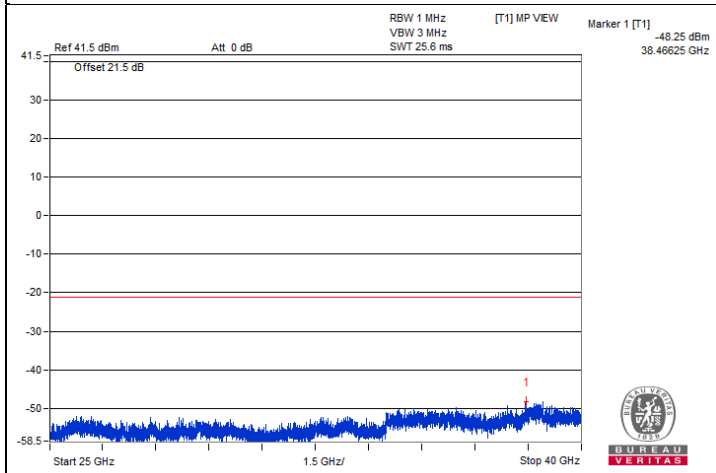
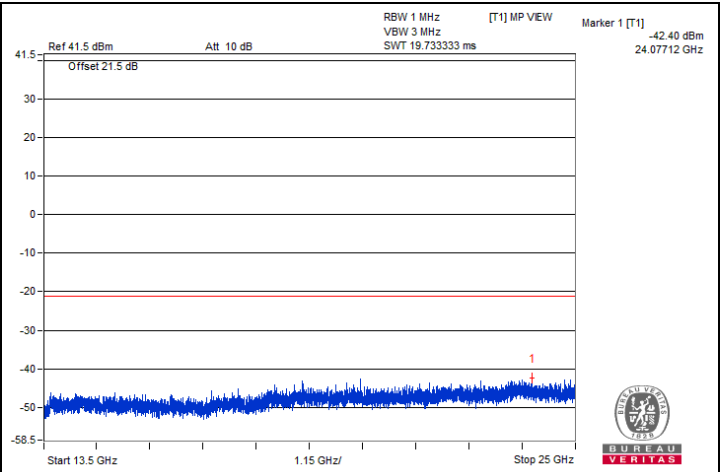
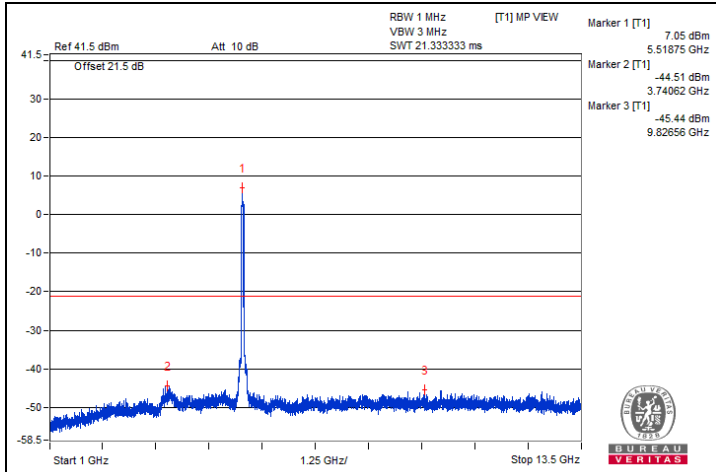

**Bandedge table**

No.	Frequency (MHz)	Emission Level (dBUV/m)	Limit (dBUV/m)	Margin (dB)	Raw Value (dBm)	Correction Factor (dB)	EIRP Level (dBm)
1	5453.68	68.54 PK	74	-5.46	-31.64	4.92	-26.72
2	5455.31	51.52 AV	54	-2.48	-48.66	4.92	-43.74
3	#5461.34	67.89 PK	68.2	-0.31	-32.29	4.92	-27.37

Remarks:

1. Margin value = Emission Level – Limit value
2. The other emission levels were very low against the limit.
3. " # " : The frequency is out of the restricted band.

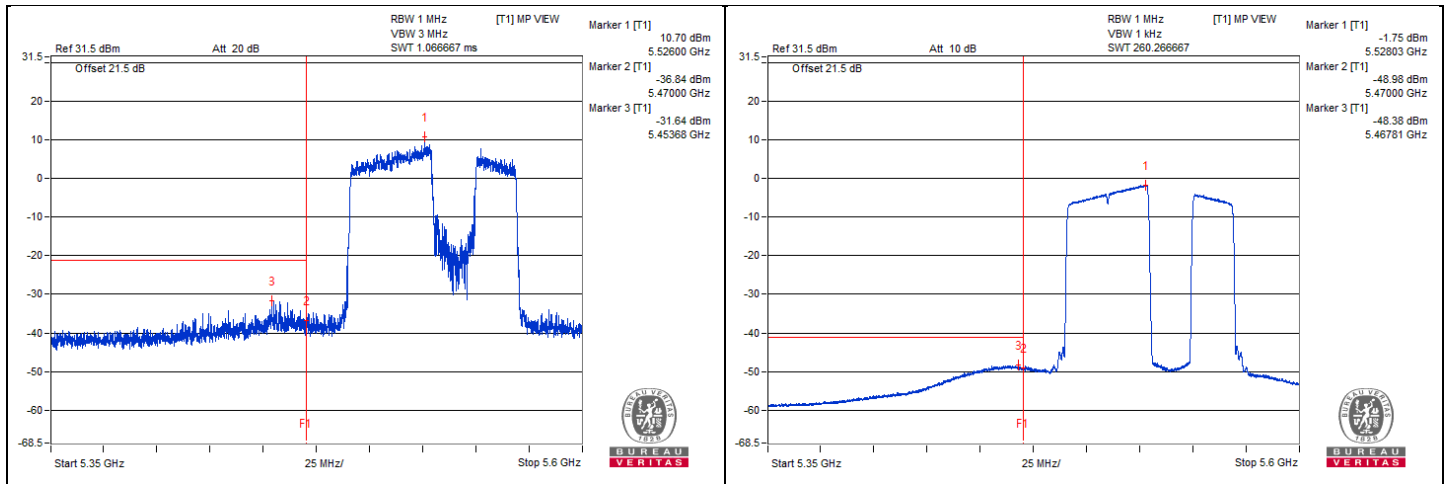

### 802.11be (EHT80) 484+242-tone MRU - Channel 138

#### Conducted spurious emission table

No.	Frequency (MHz)	Emission Level (dBuV/m)	Limit (dBuV/m)	Margin (dB)	Raw Value (dBm)	Correction Factor (dB)	EIRP Level (dBm)
1	3753.68	55.2 PK	74	-18.8	-44.98	4.92	-40.06
2	3753.12	43.35 AV	54	-10.65	-56.83	4.92	-51.91
3	7495.31	51.72 PK	74	-22.28	-48.46	4.92	-43.54
4	7495.87	40.67 AV	54	-13.33	-59.51	4.92	-54.59
5	11239.06	52.35 PK	74	-21.65	-47.83	4.92	-42.91
6	11229.68	41.17 AV	54	-12.83	-59.01	4.92	-54.09
7	#16835	52.32 PK	68.2	-15.88	-47.86	4.92	-42.94

#### Remarks:

1. Margin value = Emission Level – Limit value
2. The other emission levels were very low against the limit.
3. " # " : The frequency is out of the restricted band.

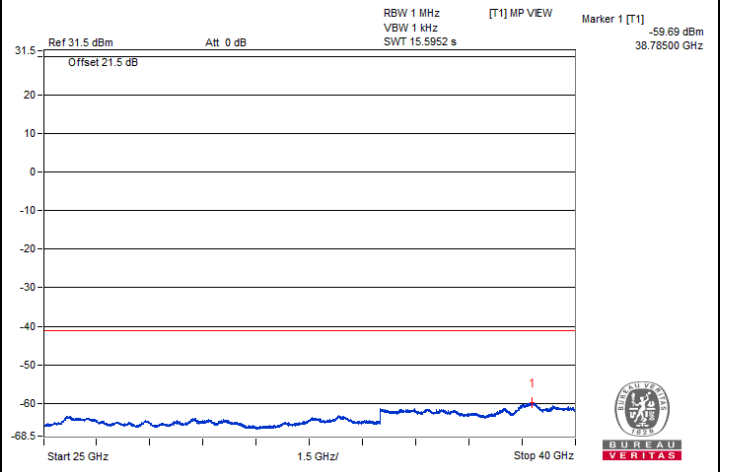
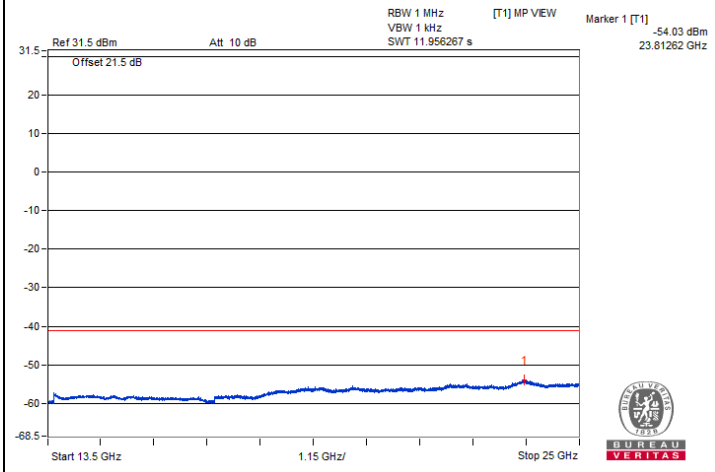
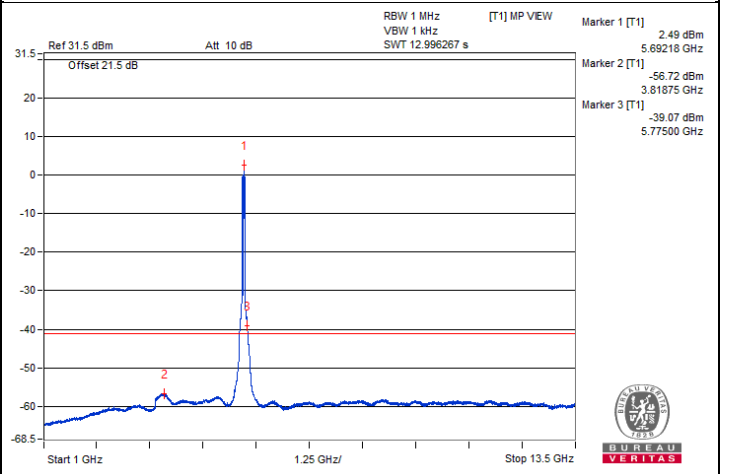
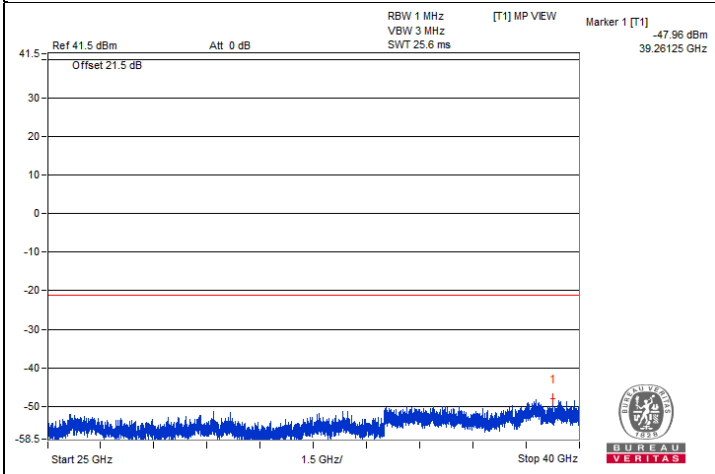
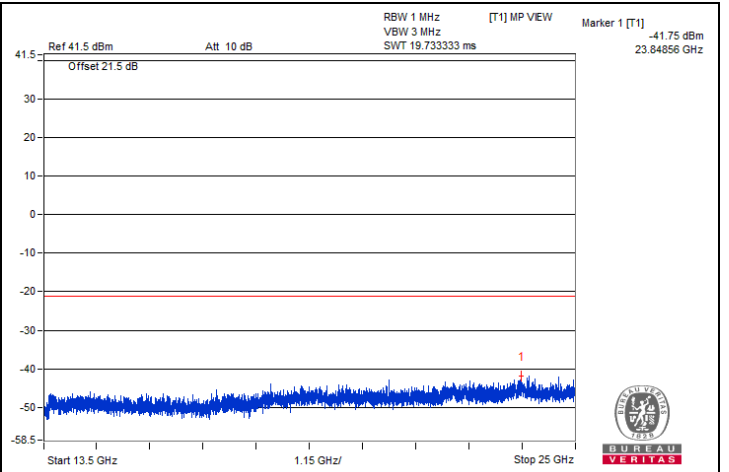
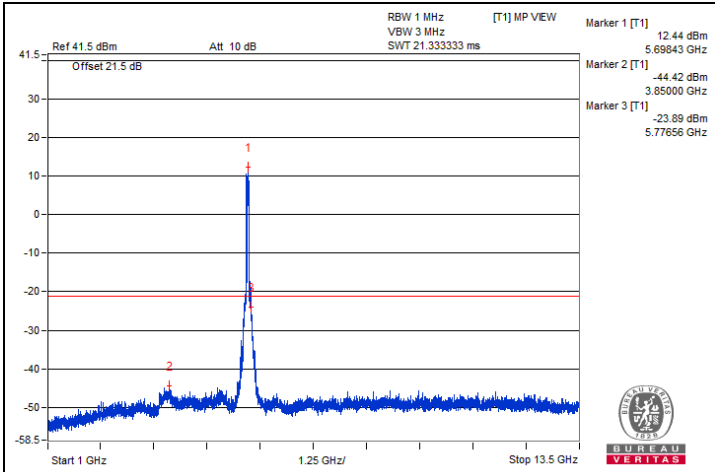

**Bandedge table**

No.	Frequency (MHz)	Emission Level (dBuV/m)	Limit (dBuV/m)	Margin (dB)	Raw Value (dBm)	Correction Factor (dB)	EIRP Level (dBm)
1	#5852.31	67.47 PK	68.2	-0.73	-32.71	4.92	-27.79

Remarks:

1. Margin value = Emission Level – Limit value
2. The other emission levels were very low against the limit.
3. " # " : The frequency is out of the restricted band.

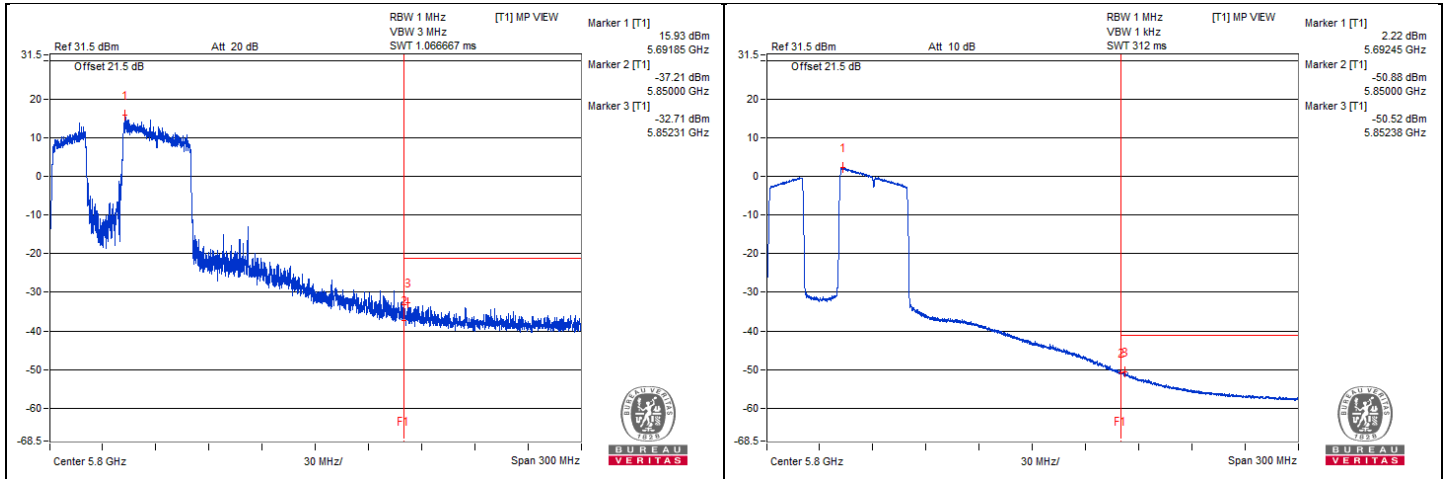



### 802.11be (EHT160) 996+484-tone MRU - Channel 50

#### Conducted spurious emission table

No.	Frequency (MHz)	Emission Level (dBuV/m)	Limit (dBuV/m)	Margin (dB)	Raw Value (dBm)	Correction Factor (dB)	EIRP Level (dBm)
1	#3484.37	51.47 PK	68.2	-16.73	-48.71	4.92	-43.79
2	#6993.75	52.87 PK	68.2	-15.33	-47.31	4.92	-42.39
3	#10506.25	53.38 PK	68.2	-14.82	-46.8	4.92	-41.88
4	15759.75	52.14 PK	74	-21.86	-48.04	4.92	-43.12
5	15756.75	42.33 AV	54	-11.67	-57.85	4.92	-52.93

Remarks:

1. Margin value = Emission Level – Limit value
2. The other emission levels were very low against the limit.
3. " # " : The frequency is out of the restricted band.

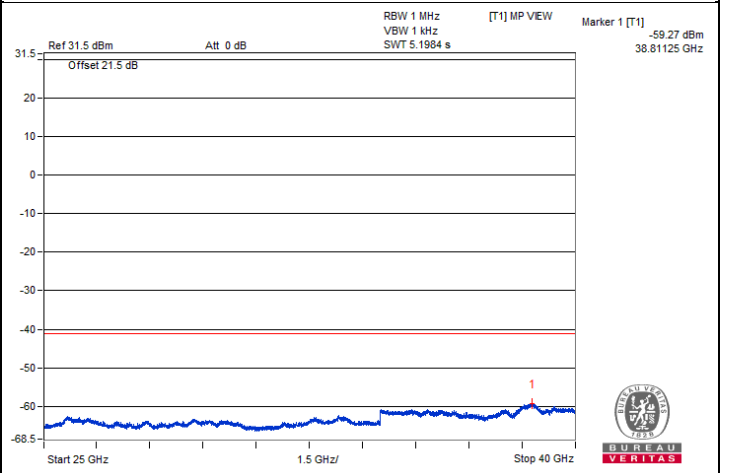
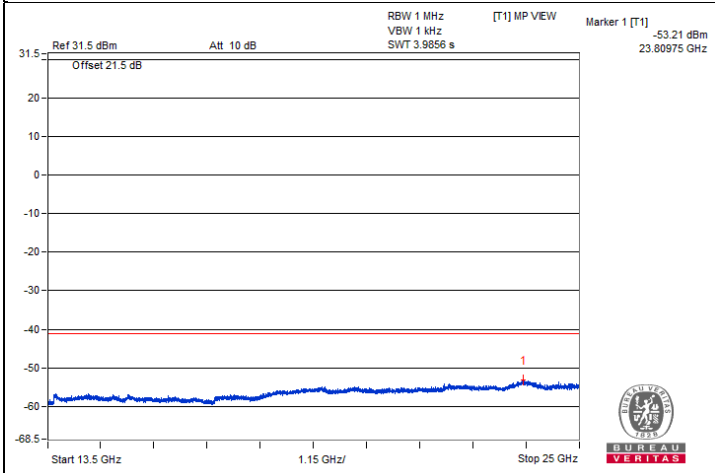
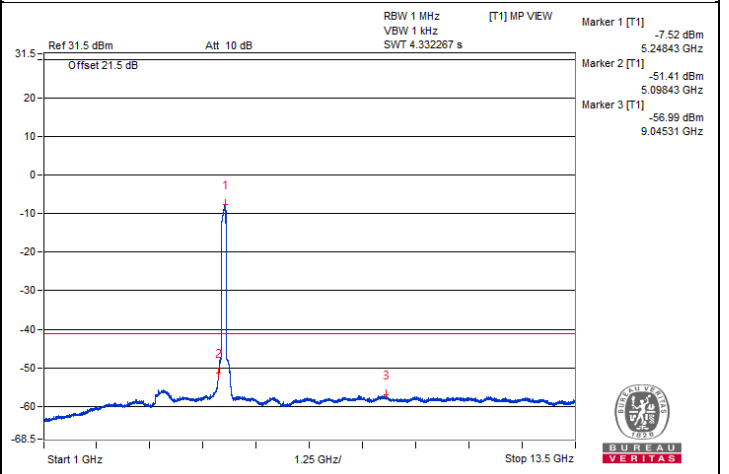
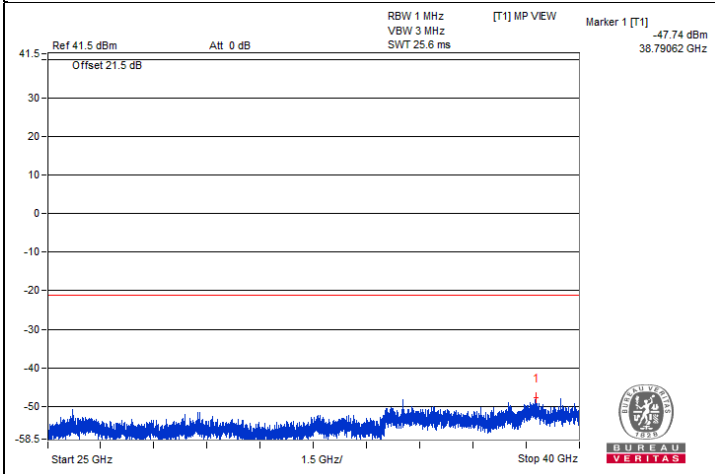
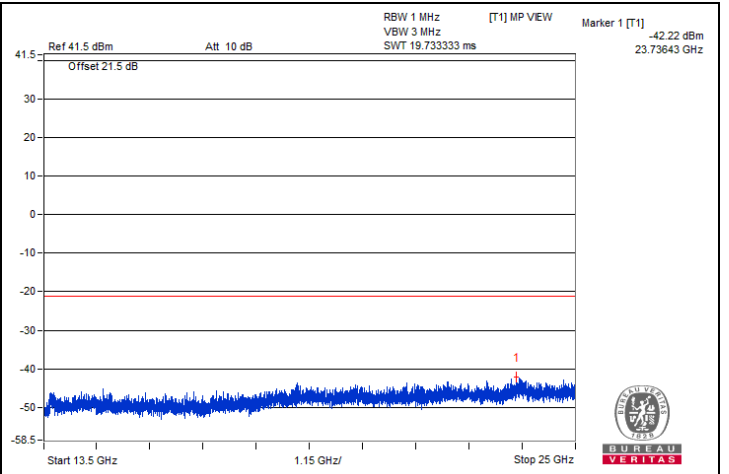
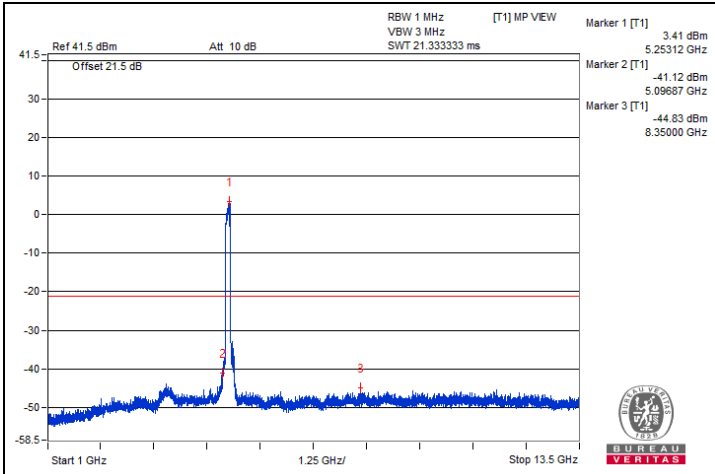

**Bandedge table**

No.	Frequency (MHz)	Emission Level (dBuV/m)	Limit (dBuV/m)	Margin (dB)	Raw Value (dBm)	Correction Factor (dB)	EIRP Level (dBm)
1	5127.57	66.08 PK	74	-7.92	-34.1	4.92	-29.18
2	5127.35	51.39 AV	54	-2.61	-48.79	4.92	-43.87

Remarks:

1. Margin value = Emission Level – Limit value
2. The other emission levels were very low against the limit.

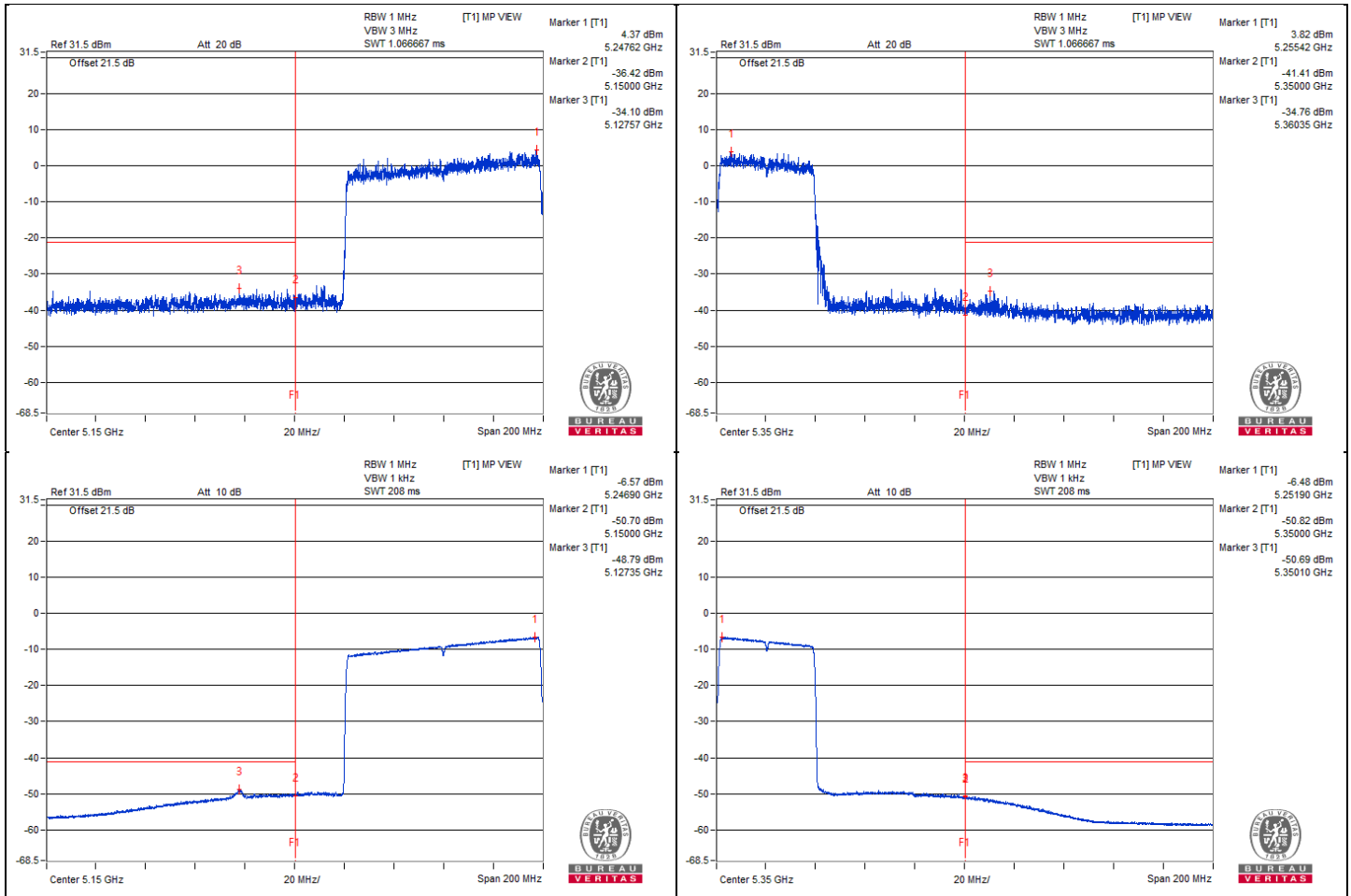

**802.11be (EHT160) 996+484-tone MRU - Channel 114**
**Conducted spurious emission table**

No.	Frequency (MHz)	Emission Level (dBuV/m)	Limit (dBuV/m)	Margin (dB)	Raw Value (dBm)	Correction Factor (dB)	EIRP Level (dBm)
1	3715.62	54.89 PK	74	-19.11	-45.29	4.92	-40.37
2	3723.43	44.03 AV	54	-9.97	-56.15	4.92	-51.23
3	7434.37	52.64 PK	74	-21.36	-47.54	4.92	-42.62
4	7434.37	41.17 AV	54	-12.83	-59.01	4.92	-54.09
5	11128.12	53.07 PK	74	-20.93	-47.11	4.92	-42.19
6	11129.68	42.35 AV	54	-11.65	-57.83	4.92	-52.91
7	#16715.68	52.03 PK	68.2	-16.17	-48.15	4.92	-43.23

**Remarks:**

1. Margin value = Emission Level – Limit value
2. The other emission levels were very low against the limit.
3. " # " : The frequency is out of the restricted band.

