

## Embedded Multi-Band Antenna for WA-P-LE-02-318

### 1.Explanation of part number :

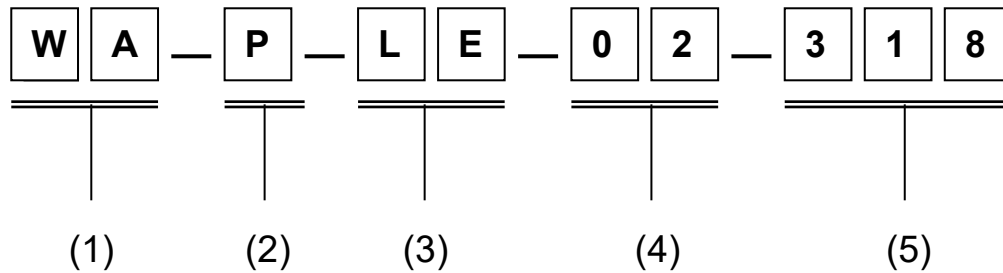

- (1) Product type : Wireless Antenna
- (2) Material : PCB
- (3) Frequency : 2400~2500 / 5150~5850 /5925~7125MHz
- (4) Coaxial Cable Type : Black Cable
- (5) Suffix : 318

### 2. Electrical Specification :

Ant. Part Number (main & aux parts)	Type	Highest Peak Gain with Cable Loss (dBi)		Cable loss (dB)		Connector Type	Cable Length (mm)	Laptop/ Host Model
		2400~2500 MHz	5150~7125 MHz	2400~2500 MHz	5150~7125 MHz			
Aux: INPAQ P/N: WA-P-LE-02-318 ASUS P/N 14008-06010200	PIFA	2.91	4.31	0.97	1.70	I-PEX MHF4-L	349	UM5606

Antenna Type	PIFA Antenna For WIFI 802.11a/b/g/n/ac/ax	
Connector Type	I-PEX MHF4-L Connector	
Cable Type	OD 1.13 LLS RF Cable	
Impedance	50Ω	
Polarization	Linear	
Radiation Pattern	Omni-directional	
Frequency Range	WLAN 802.11a/b/g/n/ac/ax	2.4~2.5GHz & 5.15~7.125 GHz
VSWR	WLAN 802.11a/b/g/n/ac/ax	≤ 3.5
Operation Temperature	-10°C ~+55°C	
Storage Temperature	-30°C ~+75°C	
Return Loss	≤ -6 dB	
Max Power	1W	

UNLESS OTHER SPECIFIED TOLERANCES ON :  
 X=N/A            X.X=N/A            X.XX=N/A  
 ANGLES=N/A            HOLEDIA=N/A



**INPAQ TECHNOLOGY CO., LTD.**

SCALE : N/A

UNIT : mm

DRAWN BY: 周敬晨

CHECKED BY: 鄭榮謀

DESIGNED BY: 張建焜

APPROVED BY: 宋承翰

THIS DRAWINGS AND SPECIFICATIONS ARE THE PROPERTY OF INPAQ TECHNOLOGY CO.,LTD.AND SHALL NOT BE REPRODUCED OR USED AS THE BASIS FOR THE MANUFACTURE OR SALE OF APPARATUS OR DEVICES WITHOUT PERMISSION

**TITLE : Embedded Multi-Band Antenna for  
WA-P-LE-02-318**

**DOCUMENT  
NO.**

**ENS000194410**

SPEC REV.  
**P0**

## 5. Electrical Specification :

Those specifications were specially defined for UM5606 model, and all characteristics were measured under the model's handset testing jig.

### 5-1. Frequency Band :

Frequency Band	MHz	MHz
Wi-Fi 6e	2400~2500	5150~7125

### 5-2. Impedance :

50 ohm nominal

### 5-3. Matching circuit :

None

### 5-4. Return loss/VSWR :

Frequency(MHz)	2400	2500	5150	5850	7125
VSWR	1.27	1.34	1.68	1.10	2.03

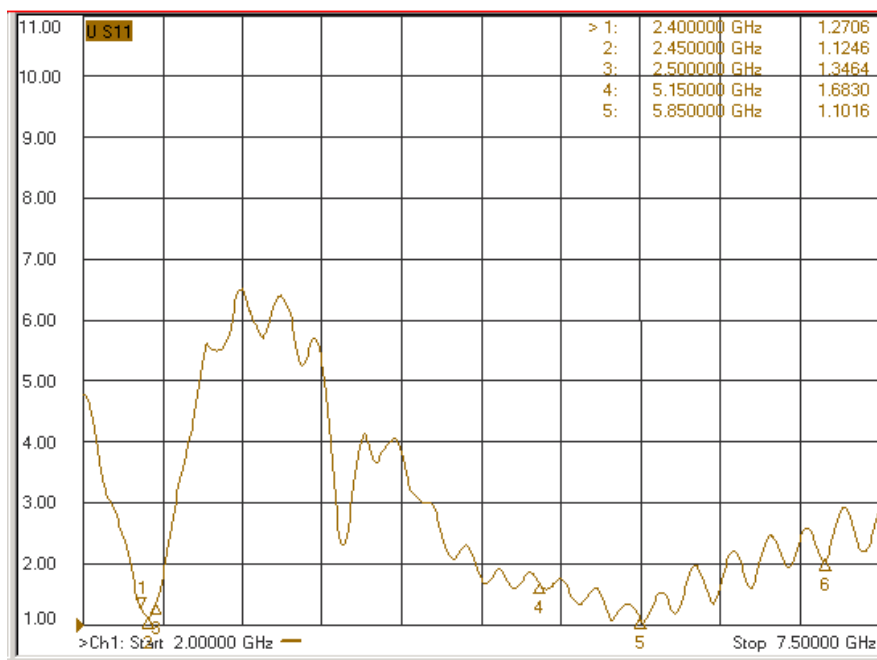

UNLESS OTHER SPECIFIED TOLERANCES ON :  
 X=N/A      X.X=N/A      X.XX=N/A  
 ANGLES=N/A      HOLEDIA=N/A



INPAQ TECHNOLOGY CO., LTD.

SCALE : N/A

UNIT : mm

DRAWN BY: 周敬晨

CHECKED BY: 鄭榮謀

DESIGNED BY: 張建焜

APPROVED BY: 宋承翰

THIS DRAWINGS AND SPECIFICATIONS ARE THE PROPERTY OF INPAQ TECHNOLOGY CO.,LTD.AND SHALL NOT BE REPRODUCED OR USED AS THE BASIS FOR THE MANUFACTURE OR SALE OF APPARATUS OR DEVICES WITHOUT PERMISSION

TITLE : Embedded Multi-Band Antenna for  
 WA-P-I-E-02-318

DOCUMENT  
 NO.

ENS000194410

SPEC REV.  
 P0

### 5-5 Gain and Radiation Pattern

#### 5-5.1 Measure method

1. Using a low loss coaxial cable to link a standard handset jig
2. Fixed this handset jig on chamber's rotator plane
3. Linking jig into network analyzer port and using a probing horn antenna to collect data.
4. Using another standard gain horn antenna to calibrated those data

#### 5-5.2 Chamber definition

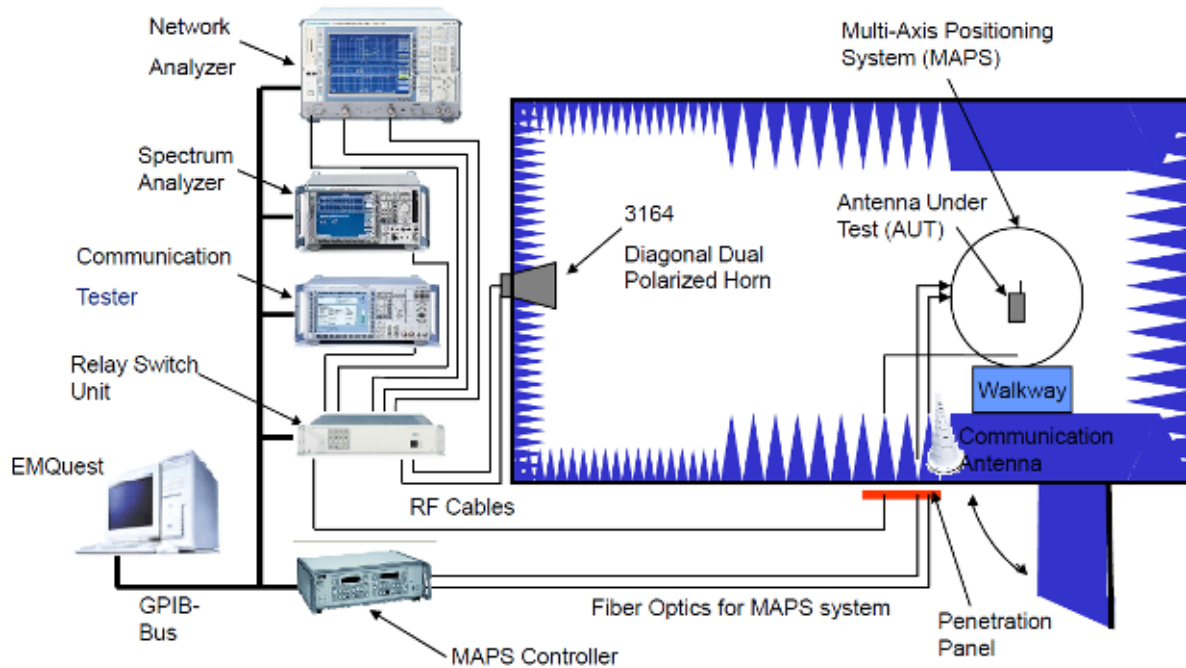

1. An anechoic chamber (10mx3mx3m) which satisfied far-field condition was applied to avoid multi-path effect
2. The quiet room region is 50cmx50cmx50cm at the center of rotator
3. The distance between DUT and standard antenna is 9.14m
4. Two measurement antennas is 3164-06 (300MHz - 6GHz) and 3164-05 (2 - 18GHz)

UNLESS OTHER SPECIFIED TOLERANCES ON :  
 X=N/A      X.X=N/A      X.XX=N/A  
 ANGLES=N/A      HOLEDIA=N/A



INPAQ TECHNOLOGY CO., LTD.

SCALE : N/A

UNIT : mm

DRAWN BY: 周敬晨

CHECKED BY: 鄭榮謀

DESIGNED BY: 張建焜

APPROVED BY: 宋承翰

THIS DRAWINGS AND SPECIFICATIONS ARE THE PROPERTY OF INPAQ TECHNOLOGY CO.,LTD.AND SHALL NOT BE REPRODUCED OR USED AS THE BASIS FOR THE MANUFACTURE OR SALE OF APPARATUS OR DEVICES WITHOUT PERMISSION

TITLE : Embedded Multi-Band Antenna for  
 WA-P-I-E-02-318

DOCUMENT NO.

ENS000194410

SPEC REV.  
 P0

### 5-5.3 Gain data and radiation pattern

Antenna gain is marked (dBi) and is based on **STANDARD HORN** antenna. The data shows Peak-Gain and Average-Gain.

Frequency (MHz)	Aux Gain Data		
	Three-dimensional peak (dBi)	Average (dBi)	Efficiency(%)
2400	2.91	-3.79	41.78
2412	2.74	-3.71	42.56
2437	2.62	-3.70	42.66
2462	2.67	-3.59	43.75
2500	2.66	-3.96	40.18
5150	3.43	-5.29	29.58
5250	3.51	-4.96	31.92
5350	3.67	-4.66	34.20
5470	3.98	-4.26	37.50
5600	4.19	-4.04	39.45
5725	4.28	-4.05	39.36
5785	4.21	-3.98	39.99
5850	4.27	-4.36	36.64
5895	4.25	-4.11	38.82
5925	4.31	-3.76	42.07
6125	4.29	-3.83	41.40
6425	4.11	-4.36	36.64
6525	4.19	-4.43	36.06
6725	2.60	-4.75	33.50
6875	2.50	-4.89	32.43
6925	2.53	-5.22	30.06
7125	2.24	-5.27	29.72

UNLESS OTHER SPECIFIED TOLERANCES ON :  
 X=N/A      X.X=N/A      X.XX=N/A  
 ANGLES=N/A      HOLEDIA=N/A



**INPAQ TECHNOLOGY CO., LTD.**

SCALE : N/A

UNIT : mm

DRAWN BY: 周敬晨

CHECKED BY: 鄭榮謀

DESIGNED BY: 張建焜

APPROVED BY: 宋承翰

THIS DRAWINGS AND SPECIFICATIONS ARE THE PROPERTY OF INPAQ TECHNOLOGY CO.,LTD.AND SHALL NOT BE REPRODUCED OR USED AS THE BASIS FOR THE MANUFACTURE OR SALE OF APPARATUS OR DEVICES WITHOUT PERMISSION

TITLE : Embedded Multi-Band Antenna for  
 WA-P-1-E-02-318

DOCUMENT  
 NO.

**ENS000194410**

SPEC REV.  
**P0**

Frequency (MHz)	Cable loss
2400-2500	0.97
5150-5250	1.44
5250-5350	1.46
5470-5725	1.49
5725-5850	1.51
5850-5925	1.52
5925-6425	1.58
6425-6525	1.62
6525-6875	1.65
6875-7125	1.70

UNLESS OTHER SPECIFIED TOLERANCES ON :  
 X=N/A          X.X=N/A          X.XX=N/A  
 ANGLES=N/A          HOLEDIA=N/A



**INPAQ TECHNOLOGY CO., LTD.**

SCALE : N/A

UNIT : mm

DRAWN BY: 周敬晨

CHECKED BY: 鄭榮謀

DESIGNED BY: 張建焜

APPROVED BY: 宋承翰

THIS DRAWINGS AND SPECIFICATIONS ARE THE PROPERTY OF INPAQ TECHNOLOGY CO.,LTD.AND SHALL NOT BE REPRODUCED OR USED AS THE BASIS FOR THE MANUFACTURE OR SALE OF APPARATUS OR DEVICES WITHOUT PERMISSION

TITLE : Embedded Multi-Band Antenna for  
 WA-P-I-E-02-318

DOCUMENT  
 NO.

**ENS000194410**

SPEC REV.  
**P0**

Auxiliary Antenna

Max Antenna 3D Radiation Pattern 2400 – 2483.5 MHz

Frequency (MHz)	Peak Gain w/ Cable Loss (dBi)
2400-2483.5	2.91

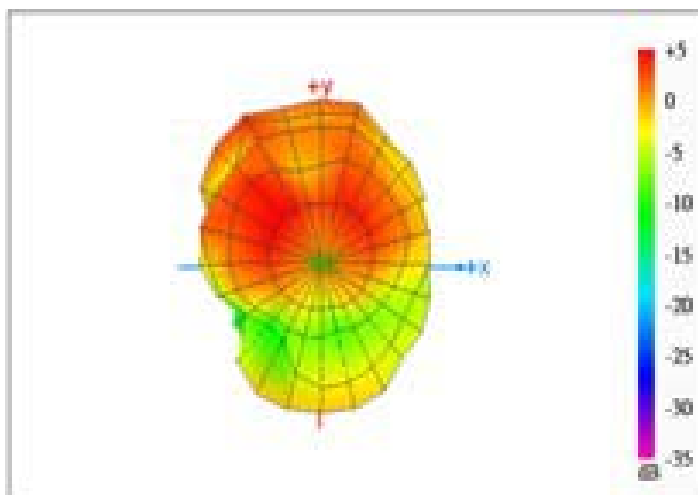

Max Antenna 3D Radiation Pattern 5150-5250 MHz

Frequency (MHz)	Peak Gain w/ Cable Loss (dBi)
5150-5250	3.51

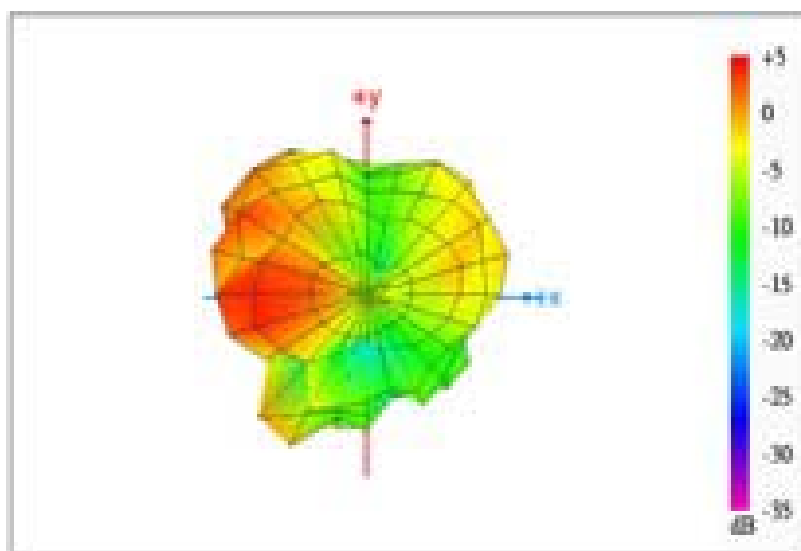

UNLESS OTHER SPECIFIED TOLERANCES ON :  
 X=N/A      X.X=N/A      X.XX=N/A  
 ANGLES=N/A      HOLEDIA=N/A



INPAQ TECHNOLOGY CO., LTD.

SCALE : N/A

UNIT : mm

DRAWN BY: 周敬晨

CHECKED BY: 鄭榮謀

DESIGNED BY: 張建焜

APPROVED BY: 宋承翰

THIS DRAWINGS AND SPECIFICATIONS ARE THE PROPERTY OF INPAQ TECHNOLOGY CO.,LTD.AND SHALL NOT BE REPRODUCED OR USED AS THE BASIS FOR THE MANUFACTURE OR SALE OF APPARATUS OR DEVICES WITHOUT PERMISSION

TITLE : Embedded Multi-Band Antenna for  
 WA-P-I-E-02-318

DOCUMENT NO.

ENS000194410

SPEC REV.  
 P0

Max Antenna 3D Radiation Pattern 5250-5350 MHz

Frequency (MHz)	Peak Gain w/ Cable Loss (dBi)
5250-5350	3.67

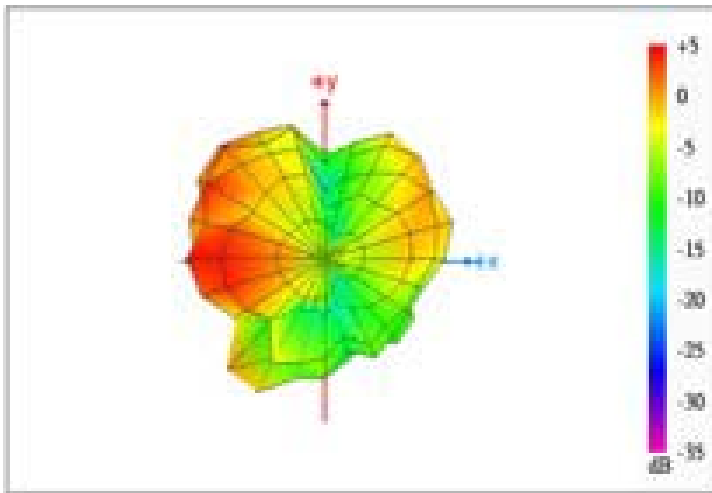

Max Antenna 3D Radiation Pattern 5470-5725 MHz

Frequency (MHz)	Peak Gain w/ Cable Loss (dBi)
5470-5725	4.28

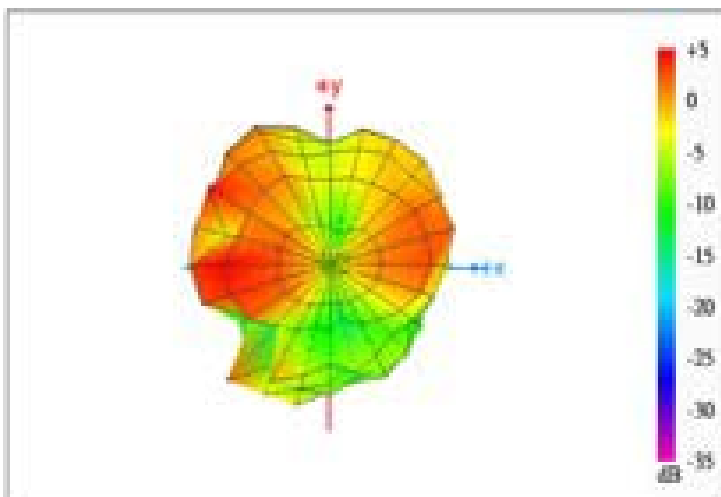

UNLESS OTHER SPECIFIED TOLERANCES ON :  
 X=N/A      X.X=N/A      X.XX=N/A  
 ANGLES=N/A      HOLEDIA=N/A



INPAQ TECHNOLOGY CO., LTD.

SCALE : N/A

UNIT : mm

DRAWN BY: 周敬晨

CHECKED BY: 鄭榮謀

DESIGNED BY: 張建焜

APPROVED BY: 宋承翰

THIS DRAWINGS AND SPECIFICATIONS ARE THE PROPERTY OF INPAQ TECHNOLOGY CO.,LTD.AND SHALL NOT BE REPRODUCED OR USED AS THE BASIS FOR THE MANUFACTURE OR SALE OF APPARATUS OR DEVICES WITHOUT PERMISSION

TITLE : Embedded Multi-Band Antenna for  
 WA-P-1-E-02-318

DOCUMENT NO.

ENS000194410

SPEC REV.  
 P0

### Max Antenna 3D Radiation Pattern 5725-5850 MHz

Frequency (MHz)	Peak Gain w/ Cable Loss (dBi)
5725-5850	4.28

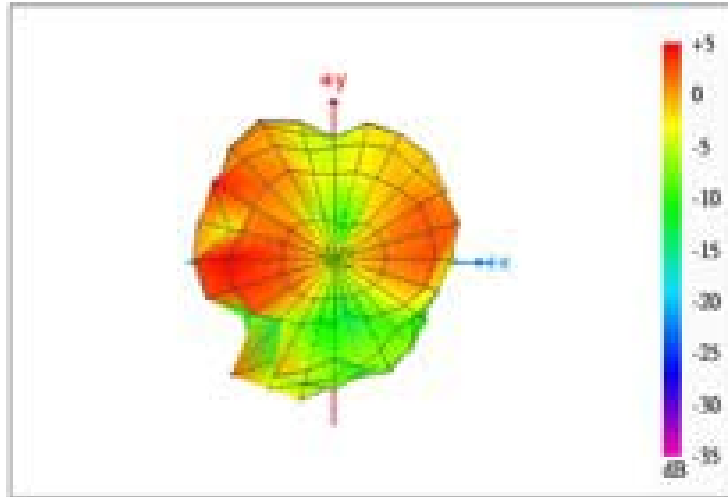

### Max Antenna 3D Radiation Pattern 5850-5895 MHz

Frequency (MHz)	Peak Gain w/ Cable Loss (dBi)
5850-5895	4.27

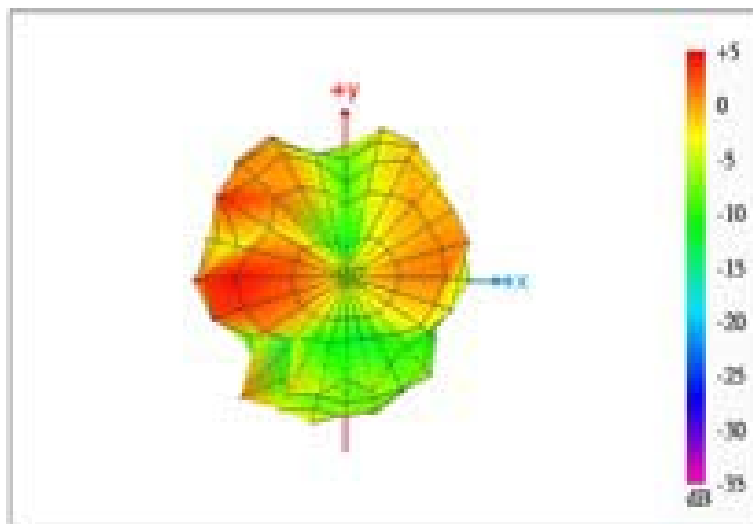

UNLESS OTHER SPECIFIED TOLERANCES ON :  
 X=N/A      X.X=N/A      X.XX=N/A  
 ANGLES=N/A      HOLEDIA=N/A



INPAQ TECHNOLOGY CO., LTD.

SCALE : N/A      UNIT : mm  
 DRAWN BY: 周敬晨      CHECKED BY: 鄭榮謀  
 DESIGNED BY: 張建焜      APPROVED BY: 宋承翰

THIS DRAWINGS AND SPECIFICATIONS ARE THE PROPERTY OF INPAQ TECHNOLOGY CO.,LTD.AND SHALL NOT BE REPRODUCED OR USED AS THE BASIS FOR THE MANUFACTURE OR SALE OF APPARATUS OR DEVICES WITHOUT PERMISSION

TITLE : Embedded Multi-Band Antenna for  
 WA-P-1-E-02-318

DOCUMENT NO.      ENS000194410

SPEC REV.      P0



## Max Antenna 3D Radiation Pattern 5925-6425 MHz

Frequency (MHz)	Peak Gain w/ Cable Loss (dBi)
5925-6425	4.31

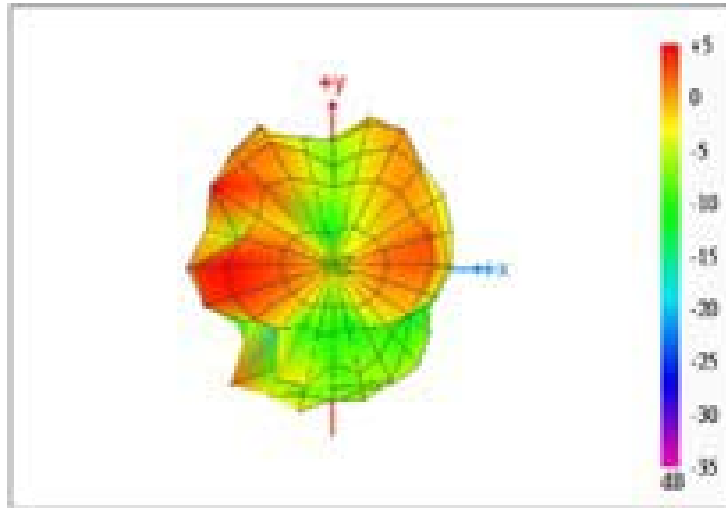

## Max Antenna 3D Radiation Pattern 6425-6525 MHz

Frequency (MHz)	Peak Gain w/ Cable Loss (dBi)
6425-6525	4.19

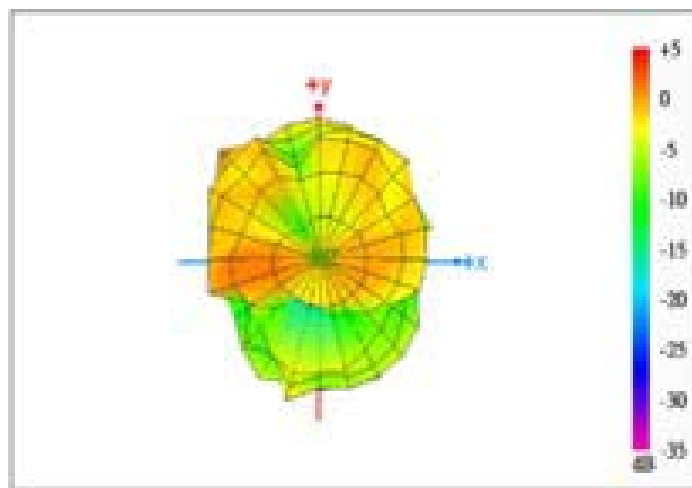

UNLESS OTHER SPECIFIED TOLERANCES ON :  
 X=N/A      X.X=N/A      X.XX=N/A  
 ANGLES=N/A      HOLEDIA=N/A



INPAQ TECHNOLOGY CO., LTD.

SCALE : N/A

UNIT : mm

DRAWN BY: 周敬晨

CHECKED BY: 鄭榮謀

DESIGNED BY: 張建焜

APPROVED BY: 宋承翰

THIS DRAWINGS AND SPECIFICATIONS ARE THE PROPERTY OF INPAQ TECHNOLOGY CO.,LTD.AND SHALL NOT BE REPRODUCED OR USED AS THE BASIS FOR THE MANUFACTURE OR SALE OF APPARATUS OR DEVICES WITHOUT PERMISSION

TITLE : Embedded Multi-Band Antenna for  
 WA-P-I-E-02-318

DOCUMENT NO.

ENS000194410

SPEC REV.  
 P0

### Max Antenna 3D Radiation Pattern 6525-6875 MHz

Frequency (MHz)	Peak Gain w/ Cable Loss (dBi)
6525-6875	4.19

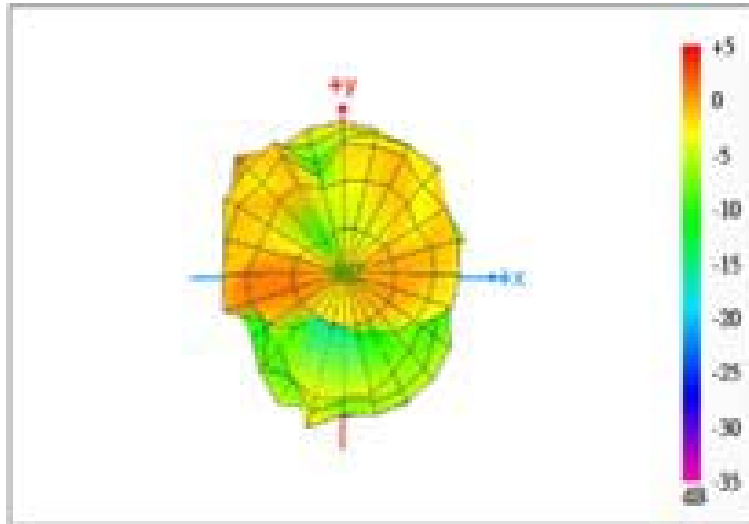

### Max Antenna 3D Radiation Pattern 6875-7125 MHz

Frequency (MHz)	Peak Gain w/ Cable Loss (dBi)
6875-7125	2.53

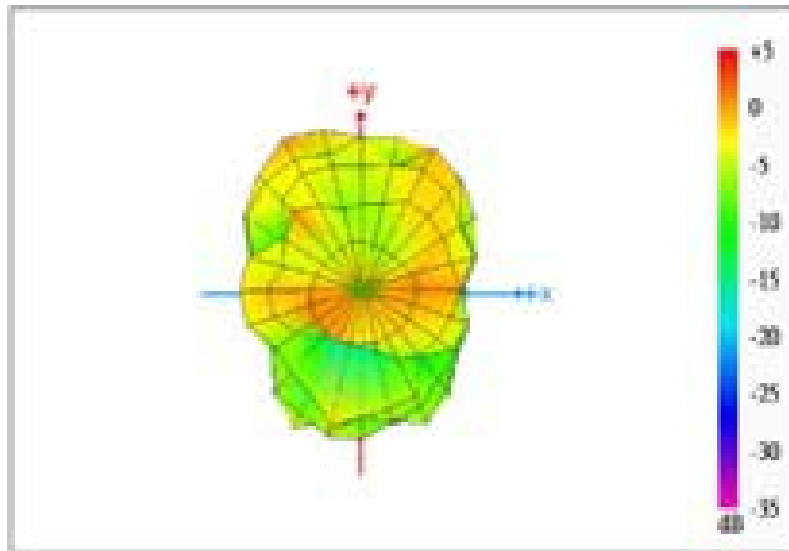

UNLESS OTHER SPECIFIED TOLERANCES ON :  
 X=N/A      X.X=N/A      X.XX=N/A  
 ANGLES=N/A      HOLEDIA=N/A



INPAQ TECHNOLOGY CO., LTD.

SCALE : N/A      UNIT : mm  
 DRAWN BY: 周敬晨      CHECKED BY: 鄭榮謀  
 DESIGNED BY: 張建焜      APPROVED BY: 宋承翰

THIS DRAWINGS AND SPECIFICATIONS ARE THE PROPERTY OF INPAQ TECHNOLOGY CO.,LTD.AND SHALL NOT BE REPRODUCED OR USED AS THE BASIS FOR THE MANUFACTURE OR SALE OF APPARATUS OR DEVICES WITHOUT PERMISSION

TITLE : Embedded Multi-Band Antenna for  
 WA-P-1-E-02-318

DOCUMENT NO.      ENS000194410

SPEC REV.      P0

6. 外箱貼附 Cable 的 UL 標籤：

The appearance of cable UL label is according to drawing Figure 7-1-1

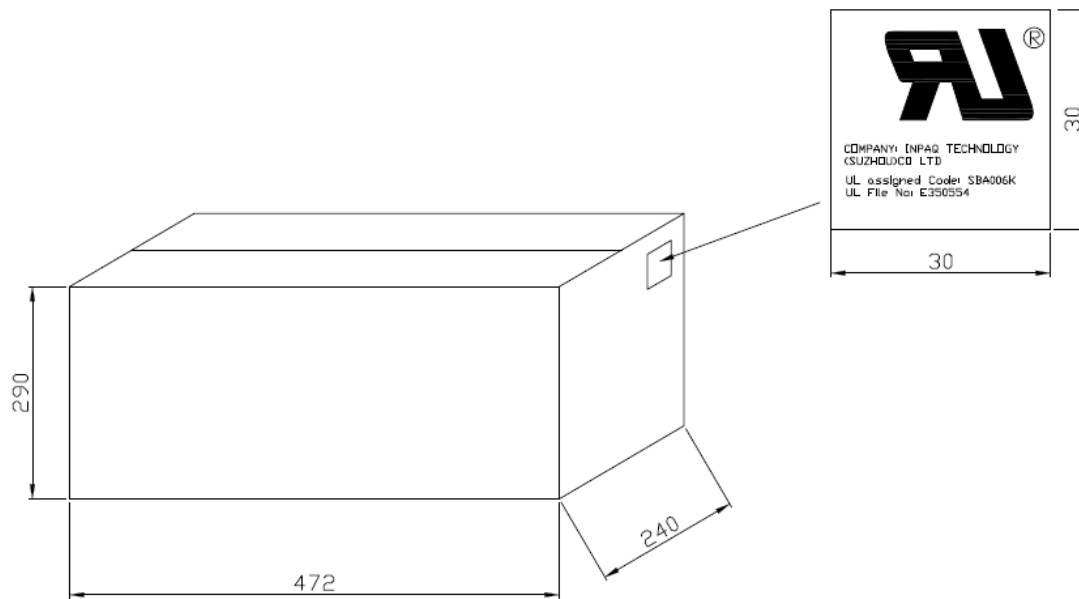

帶線材的產品出貨時皆需貼附此標籤

UNLESS OTHER SPECIFIED TOLERANCES ON : X=N/A      X.X=N/A      X.XX=N/A ANGLES=N/A      HOLEDIA=N/A			<b>INPAQ TECHNOLOGY CO., LTD.</b>	
SCALE : N/A	UNIT : mm			THIS DRAWINGS AND SPECIFICATIONS ARE THE PROPERTY OF INPAQ TECHNOLOGY CO.,LTD.AND SHALL NOT BE REPRODUCED OR USED AS THE BASIS FOR THE MANUFACTURE OR SALE OF APPARATUS OR DEVICES WITHOUT PERMISSION
DRAWN BY: 周敬晨	CHECKED BY: 鄭榮謀			
DESIGNED BY: 張建焜	APPROVED BY: 宋承翰			
TITLE : Embedded Multi-Band Antenna for WA-P-I-E-02-318		DOCUMENT NO.	ENS000194410	SPEC REV. P0