

**Nemko Test Report:** 140724-1TRFWL

**Applicant:** BelAir Networks Inc.  
603 March Road,  
Ottawa, ON  
K2K 2M5 Canada

**Apparatus:** DRU

**FCC ID:** RAR30002001

**In Accordance With:** FCC Part 15 Subpart C, 15.247  
FHSS System and Digitally Modulated Radiators  
902–928 MHz, 2400–2483.5 MHz, 5725–5850 MHz

**Authorized By:** Andrey Adelberg, Senior Wireless/EMC Specialist

**Date:** March 1, 2010

**Total Number of Pages:** 29

## TABLE OF CONTENTS

<b>Section 1 : Report Summary .....</b>	<b>3</b>
<b>Section 2 : Equipment Under Test.....</b>	<b>4</b>
2.1 Identification of Equipment Under Test (EUT).....	4
2.2 Accessories.....	4
2.3 EUT Description.....	4
2.4 Technical Specifications of the EUT .....	5
2.5 EUT Setup diagram .....	5
2.6 Operation of the EUT during testing .....	6
2.7 Modifications incorporated in the EUT .....	6
<b>Section 3 : Test Conditions.....</b>	<b>7</b>
3.1 Specifications .....	7
3.2 Deviations From Laboratory Test Procedures .....	7
3.3 Test Environment .....	7
3.4 Measurement Uncertainty.....	7
3.5 Test Equipment.....	8
<b>Section 4 : Results Summary .....</b>	<b>9</b>
4.1 FCC Part 15 Subpart C : Test Results .....	9
<b>Appendix A : Test Results.....</b>	<b>10</b>
Clause 15.207(a) Powerline Conducted Emissions .....	10
Clause 15.209(a) Radiated Emissions within Restricted Bands .....	12
Clause 15.247(a)(2) 6 dB bandwidth for systems using digital modulation techniques .....	14
Clause 15.247(b)(3) Maximum peak output power of systems using digital modulation in the 902–928 MHz, 2400–2483.5 MHz and 5725–5850 MHz bands.....	16
Clause 15.247(b)(4) Maximum peak output power .....	16
Clause 15.247(c)(1) Fixed point-to-point Operation with directional antenna gains greater than 6 dBi .....	16
Clause 15.247(d) Conducted Spurious Emissions .....	20
<b>Appendix B : Setup Photographs .....</b>	<b>28</b>
<b>Appendix C : Block Diagram of Test Setups.....</b>	<b>29</b>

## Section 1 : Report Summary

These tests were conducted on a sample of the equipment for the purpose of demonstrating compliance with Part 15, Subpart C. Radiated tests were conducted in accordance with ANSI C63.4-2003.

The assessment summary is as follows:

<b>Apparatus Assessed:</b>	DRU
<b>Specification:</b>	FCC Part 15 Subpart C, 15.247
<b>Compliance Status:</b>	Complies
<b>Exclusions:</b>	None
<b>Non-compliances:</b>	None
<b>Report Release History:</b>	Original Release
<b>Test Location:</b>	Nemko Canada Inc. 303 River Road Ottawa, Ontario K1V 1H2
<b>Registration Number:</b>	176392 (3 m Semi-Anechoic Chamber)
<b>Tests Performed By:</b>	Kevin Ma, Wireless/EMC Specialist
<b>Test Dates:</b>	January 2010

Note that the results contained in this report relate only to the items tested and were obtained in the period between the date of initial receipt of samples and the date of issue of the report.

This test report has been completed in accordance with the requirements of ISO/IEC 17025. All results contain in this report are within Nemko Canada's ISO/IEC 17025 accreditation.

Nemko Canada Inc. authorizes the applicant to reproduce this report provided it is reproduced in its entirety and for use by the company's employees only.

Any use which a third party makes of this report, or any reliance on or decisions to be made based on it, are the responsibility of such third parties. Nemko Canada Inc. accepts no responsibility for damages, if any, suffered by any third party as a result of decisions made or actions based on this report.

## Section 2 : Equipment Under Test

### 2.1 Identification of Equipment Under Test (EUT)

The following information identifies the EUT under test:

Type of Equipment:	DRU 2.4 GHz Radio Module
Brand Name:	BelAir
Model Name or Number:	DRU
Part Number:	B2CH112AA-AA01
Nemko Sample Number:	1
FCC ID:	RAR30002001
Date of Receipt:	January 18, 2010

### 2.2 Accessories

The following information identifies accessories used to exercise the EUT during testing:

Description:	DC power supply
Brand Name:	BelAir
Model Name or Number:	SDS60US05B-XD0034A
Serial Number:	05455686
Nemko Sample Number:	1
Connection Port:	DC port

Description:	Laptop
Brand Name:	DELL
Model Name or Number:	Latitude D600
Nemko Sample Number:	2
Connection Port:	Ethernet connection

### 2.3 EUT Description

The EUT is a MIMO combo WiFi module designed to operate in the 2.4–2.4835 GHz band, and 5.725–5.85 GHz band, 2×3 MIMO for 2.4 GHz, and 2×2 MIMO for 5 GHz.

There are two independent radio units. This report covers the 2.4 GHz radio, FCC ID: RAR30002001. The 5 GHz radio has is assessed under FCC ID: RAR30005001.

## 2.4 Technical Specifications of the EUT

**Operating Band:** 2400–2483.5 MHz

**Operating Frequency:** 2412–2462 MHz

**Modulation:** 802.11 b, g & n

**Channel Bandwidth:** 20 MHz

**Emission Designator:** W7D

**Antenna Data:**

1. 5 dBi, BelAir, BMAG00287-A
2. 8 dBi, BelAir, BNCKG0057
3. 8 dBi, BelAir, BMDG30083-A01
4. 17 dBi, BelAir, BNCKG0082
5. 18 dBi, BelAir, BNCKG0083

**Antennas 1–2 are Omni directional; 3–5 are directional antennas that are used exclusively for fixed, point-to-point operations.**

**Power Supply Requirements:** 120 VAC, 60 Hz

## 2.5 EUT Setup diagram

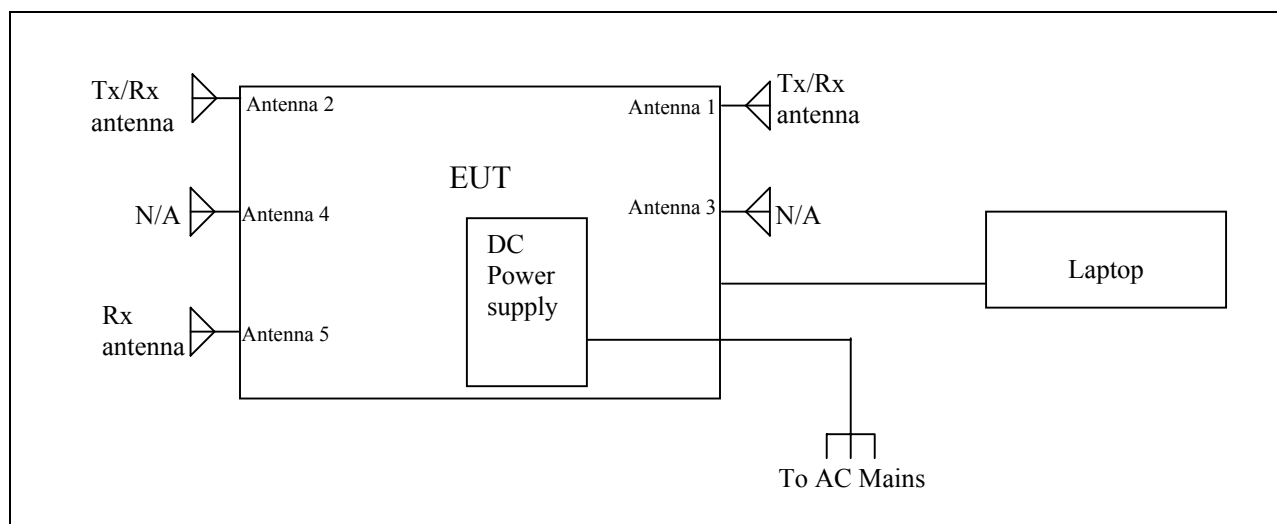

## **2.6 Operation of the EUT during testing**

The EUT was controlled to transmit at desired frequency from laptop.

## **2.7 Modifications incorporated in the EUT**

There were no modifications performed to the EUT during this assessment.

## **Section 3 : Test Conditions**

### **3.1 Specifications**

The apparatus was assessed against the following specifications:

FCC Part 15 Subpart C, 15.247

FHSS System and Digitally Modulated Radiators  
902–928 MHz, 2400–2483.5 MHz, 5725–5850 MHz

### **3.2 Deviations From Laboratory Test Procedures**

No deviations were made from laboratory test procedures.

### **3.3 Test Environment**

All tests were performed under the following environmental conditions:

Temperature range	:	15–30 °C
Humidity range	:	20–75 %
Pressure range	:	86–106 kPa
Power supply range	:	±5 % of rated voltages

### **3.4 Measurement Uncertainty**

Nemko Canada measurement uncertainty has been calculated using guidance of UKAS LAB 34:2003 and TIA-603-B Nov 7, 2002. All calculations have been performed to provide a confidence level of 95 % and can be found in Nemko Canada document MU-003.

### 3.5 Test Equipment

Equipment	Manufacturer	Model No.	Asset/Serial No.	Cal. Date	Next Cal.
3 m EMI Test Chamber	TDK	SAC-3	FA002047	May 06/09	May 06/10
Biconical	Sunol	BC2	FA002078	Nov. 12/09	Nov. 12/10
Log Periodic Antenna	Sunol	LP5	FA002077	Nov. 18/09	Nov. 18/10
Bilog	Sunol	JB3	FA002108	Jan. 18/10	Jan. 18/11
Flush Mount Turntable	Sunol	FM2022	FA002082	NCR	NCR
Controller	Sunol	SC104V	FA002060	NCR	NCR
Mast	Sunol	TLT2	FA002061	NCR	NCR
International Power Supply	California Inst.	3001i	FA001021	Jan. 13/09	Jan. 13/11
Spectrum Analyzer	Rohde & Schwarz	FSU46	FA001877	Sep. 29/09	Sep. 29/10
Horn Antenna #2	EMCO	3115	FA000825	Jan. 21/09	Jan. 21/11
1 – 18 GHz Amplifier	JCA	JCA118-503	FA002091	Oct 07/09	Oct 07/10
Receiver/Spectrum Analyzer	Rohde & Schwarz	ESU 40	FA002071	Nov. 30/09	Nov. 30/10
Horn 18 – 26.5 GHz	Electro-Metrics	SH-50/60-1	FA000479	COU	COU
18.0 – 26.0 GHz Amplifier	NARDA	BBS-1826N612	FA001550	COU	COU
Multimeter	Fluke	16	FA001831	Jan 13/09	Jan 13/11
Air probe	Fluke	None	FA001248	NCR	NCR
Attenuator	Narda	776B-20	FA001153	COU	COU
Combiner	Mini-circuits	ZA3PD-4	FA001156	COU	COU

COU – Calibrate on Use

NCR – No Calibration Required



## Section 4 : Results Summary

This section contains the following:

### FCC Part 15 Subpart C : Test Results

The column headed 'Required' indicates whether the associated clauses were invoked for the apparatus under test. The following abbreviations are used:

- N No : not applicable / not relevant.
- Y Yes : Mandatory i.e. the apparatus shall conform to these tests.
- N/T Not Tested, mandatory but not assessed. (See Report Summary)

#### 4.1 FCC Part 15 Subpart C : Test Results

Part 15	Test Description	Required	Result
15.31(e)	Variation of power supply	Y	PASS
15.207(a)	Powerline Conducted Emissions	Y	PASS
15.209(a)	Radiated Emissions within Restricted Bands	Y	PASS
15.247(a)(1)	Frequency hopping systems	N	
15.247(a)(1)(i)	Frequency hopping systems operating in the 902–928 MHz band	N	
15.247(a)(1)(ii)	Frequency hopping systems operating in the 5725–5850 MHz band	N	
15.247(a)(1)(iii)	Frequency hopping systems operating in the 2400–2483.5 MHz band	N	
15.247(a)(2)	6 dB BW for systems using digital modulation techniques	Y	PASS
15.247(b)(1)	Maximum peak output power of Frequency hopping systems operating in the 2400–2483.5 MHz band and 5725–5850 MHz band	N	
15.247(b)(2)	Maximum peak output power of Frequency hopping systems operating in the 902–928 MHz band	N	
15.247(b)(3)	Maximum peak output power of systems using digital modulation in the 902–928 MHz, 2400–2483.5 MHz, and 5725–5850 MHz bands	Y	PASS
15.247(b)(4)	Maximum peak output power	Y	PASS
15.247(c)(1)	Fixed point-to-point Operation with directional antenna gains greater than 6 dBi	Y	PASS
15.247(c)(2)	Transmitters operating in the 2400–2483.5 MHz band that emit multiple directional beams	N	
15.247(d)	Conducted Spurious Emissions	Y	PASS
15.247(e)	Power Spectral Density for Digitally Modulated Devices	Y	PASS
15.247(f)	Time of Occupancy for Hybrid Systems	N	



## Appendix A : Test Results

### Clause 15.207(a) Powerline Conducted Emissions

Frequency of Conducted limit (dB $\mu$ V)		
Emission (MHz)	Quasi-peak	Average
0.15–0.5	66 to 56*	56 to 46*
0.5–5	56	46
5–30	60	50

\* Decreases with the logarithm of the frequency.

**Test Results:** Pass

#### Additional Observations:

All plots were obtained using a receiver with an IF of 9 kHz using a Quasi-Peak and Average detector. The plots have been corrected with the cable loss and LISN loss to show compliance.

**Phase:**

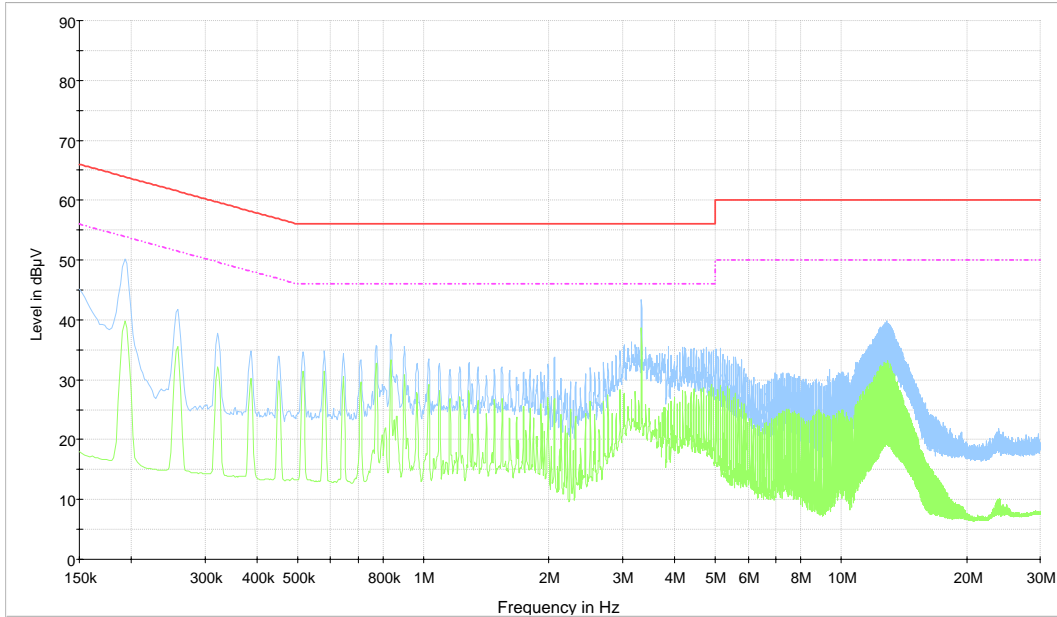

— CISPR 22 Mains QP Class B.LimitLine - - - CISPR 22 Mains AV Class B.LimitLine — Preview Result 1 — Preview Result 2

**Neutral:**

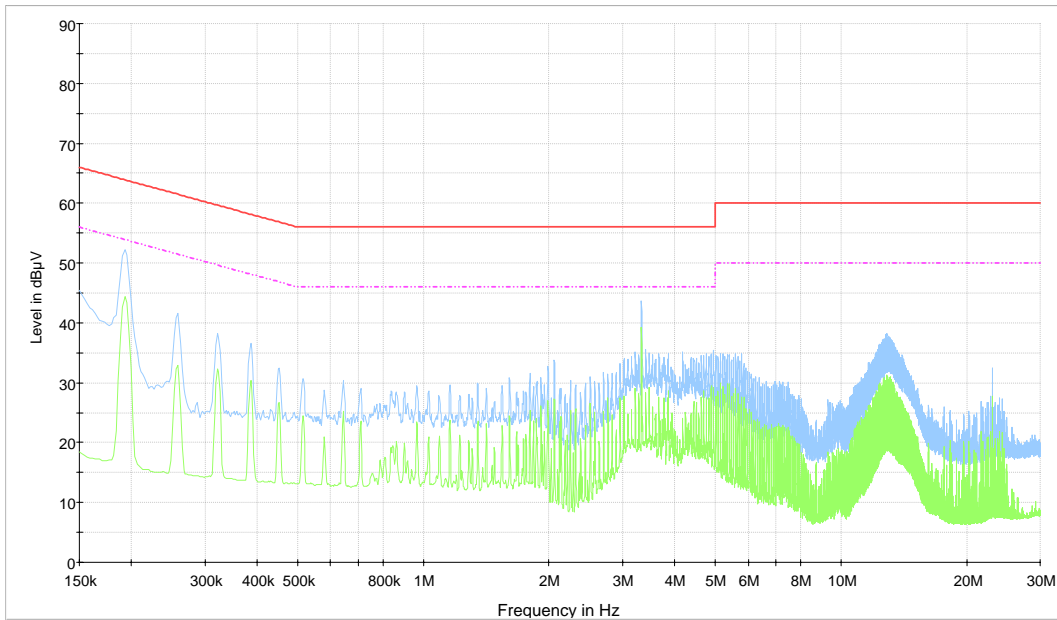

— CISPR 22 Mains QP Class B.LimitLine - - - CISPR 22 Mains AV Class B.LimitLine — Preview Result 1 — Preview Result 2

**Clause 15.209(a) Radiated Emissions within Restricted Bands**

Except as provided elsewhere in this subpart, the emissions from an intentional radiator shall not exceed the field strength levels specified in the following table:

Frequency (MHz)	Field Strength		Measurement Distance (meters)
	( $\mu$ V/m)	(dB $\mu$ V/m)	
0.009–0.490	2400/F	67.6–20log(F)	300
0.490–1.705	24000/F	87.6–20log(F)	30
1.705–30.0	30	29.5	30
30–88	100	40.0	3
88–216	150	43.5	3
216–960	200	46.0	3
Above 960	500	54.0	3

Note: F = fundamental frequency in kHz

**Test Results:** Pass

**Additional Observations:**

The Spectrum was searched from 30 MHz to 25 GHz for low (2412 MHz), mid (2437 MHz) and high (2462 MHz) carrier frequencies.

These results apply to emissions found in the Restricted bands defined in FCC Part 15 Subpart C, 15.205.

Peak Detector with 100 kHz/300 kHz RBW/VBW was used for measurements below 1 GHz and 1 MHz/3 MHz RBW/VBW for frequencies above 1 GHz. Since EUT has 100 % duty cycle average measurements were performed at the frequencies above 1 GHz with 1 MHz/10 Hz RBW/VBW spectrum analyzer settings.

Only the worst-case test results are provided.

**802.11b**

Antenna	Channel, MHz	Frequency, MHz	FS Peak, dBµV/m	FS Peak Limit, dBµV/m	Margin, dB	FS Avg, dBµV/m	FS Avg Limit, dBµV/m	Margin, dB
Omni 5 dBi	2412	2387.3	70.83	74.00	3.17	52.41	54.00	1.59
	2437	2390.0	60.41	74.00	13.59	50.40	54.00	3.60
	2462	2488.2	67.54	74.00	6.46	53.37	54.00	0.63
Omni 8 dBi	2412	2390.0	73.68	74.00	0.32	53.02	54.00	0.98
	2462	2487.9	68.57	74.00	5.43	52.49	54.00	1.51
Directional 8 dBi	2412	2387.1	70.38	74.00	3.62	52.21	54.00	1.79
	2462	2488.2	64.46	74.00	9.54	53.07	54.00	0.93
Directional 17 dBi	2412	2390.0	72.18	74.00	1.82	53.76	54.00	0.24
	2462	2487.7	65.12	74.00	8.88	52.98	54.00	1.02
Helical 18 dBi	2412	2390.0	72.42	74.00	1.58	52.61	54.00	1.39
	2462	2483.5	64.12	74.00	9.88	52.86	54.00	1.14

**802.11g**

Antenna	Channel, MHz	Frequency, MHz	FS Peak, dBµV/m	FS Peak Limit, dBµV/m	Margin, dB	FS Avg, dBµV/m	FS Avg Limit, dBµV/m	Margin, dB
Omni 5 dBi	2412	2390.0	72.87	74.00	1.13	53.93	54.00	0.07
	2462	2483.5	67.54	74.00	6.46	52.89	54.00	1.11
Omni 8 dBi	2412	2390.0	73.56	74.00	0.44	53.69	54.00	0.31
	2462	2483.5	73.58	74.00	0.42	53.64	54.00	0.36
Directional 8 dBi	2412	2390.0	72.21	74.00	1.79	53.89	54.00	0.11
	2462	2483.5	73.83	74.00	0.17	53.05	54.00	0.95
Directional 17 dBi	2412	2390.0	69.11	74.00	4.89	53.97	54.00	0.03
	2462	2483.5	71.18	74.00	2.82	52.89	54.00	1.11
Helical 18 dBi	2412	2390.0	70.28	74.00	3.72	52.61	54.00	1.39
	2462	2485.6	69.06	74.00	4.94	51.89	54.00	2.11

**802.11n**

Antenna	Channel, MHz	Frequency, MHz	FS Peak, dBµV/m	FS Peak Limit, dBµV/m	Margin, dB	FS Avg, dBµV/m	FS Avg Limit, dBµV/m	Margin, dB
Omni 5 dBi	2412	2390.0	73.68	74.00	0.32	53.65	54.00	0.35
	2462	2483.5	72.03	74.00	1.97	53.56	54.00	0.44
Omni 8 dBi	2412	2390.0	73.41	74.00	0.59	53.24	54.00	0.76
	2462	2483.5	73.13	74.00	0.87	53.17	54.00	0.83
Directional 8 dBi	2412	2390.0	73.92	74.00	0.08	53.51	54.00	0.49
	2462	2483.5	72.98	74.00	1.02	52.90	54.00	1.10
Directional 17 dBi	2412	2390.0	73.51	74.00	0.49	53.66	54.00	0.34
	2462	2483.5	71.86	74.00	2.14	53.12	54.00	0.88
Helical 18 dBi	2412	2390.0	68.86	74.00	5.14	52.41	54.00	1.59
	2462	2483.5	69.03	74.00	4.97	52.56	54.00	1.44

Note: Field Strength (FS) result includes antenna factor, cable losses and amplifier gain where applicable.

There were no additional emissions or change in existing emissions when both the 2.4 GHz radio and 5 GHz radios operated simultaneously.

**Clause 15.247(a)(2) 6 dB bandwidth for systems using digital modulation techniques**

Systems using digital modulation techniques may operate in the 902–928 MHz, 2400–2483.5 MHz and 5725–5850 MHz bands. The minimum 6 dB bandwidth shall be at least 500 kHz.

**Test Results:** Pass

**Additional Observations:**

The peak detector was used with 100 kHz/300 kHz RBW/VBW.  
 The span was wider than 6 dB bandwidth.

**802.11b**

Frequency, MHz	6 dB BW, MHz	Limit, MHz	Margin, MHz
2412	11.105	0.5	10.605
2437	12.067	0.5	11.567
2462	11.057	0.5	10.557

6 dB BW spectral plot sample:

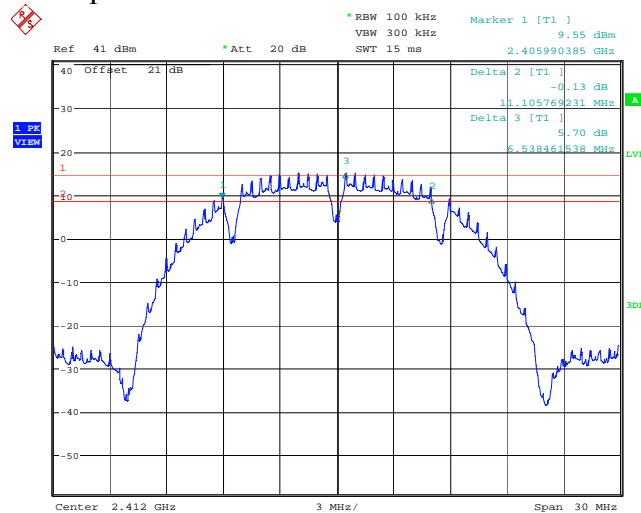

Date: 21.JAN.2010 10:37:24

**802.11g**

Frequency, MHz	6 dB BW, MHz	Limit, MHz	Margin, MHz
2412	16.346	0.5	15.846
2437	16.009	0.5	15.509
2462	15.769	0.5	15.269

6 dB BW spectral plot sample:

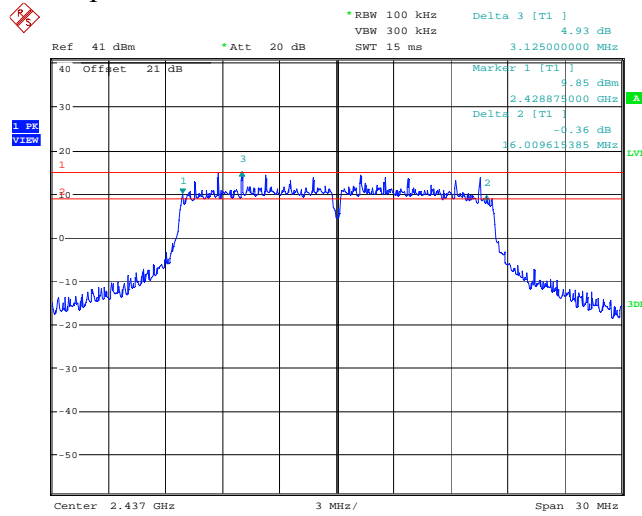

**802.11n**

Frequency, MHz	6 dB BW, MHz	Limit, MHz	Margin, MHz
2412	17.259	0.5	16.759
2437	17.019	0.5	16.519
2462	16.730	0.5	16.230

6 dB BW spectral plot sample:

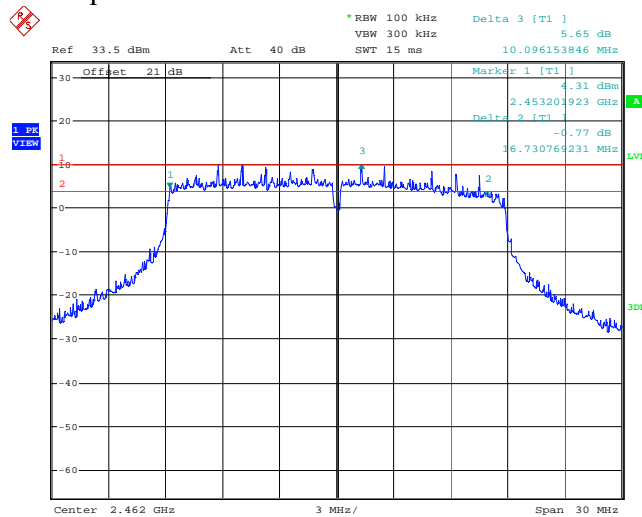

**Clause 15.247(b)(3) Maximum peak output power of systems using digital modulation in the 902–928 MHz, 2400–2483.5 MHz and 5725–5850 MHz bands**

For systems using digital modulation in the 902–928 MHz, 2400–2483.5 MHz, and 5725–5850 MHz bands: 1 W. As an alternative to a peak power measurement, compliance with the 1 W limit can be based on a measurement of the maximum conducted output power. Maximum Conducted Output Power is defined as the total transmit power delivered to all antennas and antenna elements averaged across all symbols in the signalling alphabet when the transmitter is operating at its maximum power control level. Power must be summed across all antennas and antenna elements. The average must not include any time intervals during which the transmitter is off or is transmitting at a reduced power level. If multiple modes of operation are possible (e.g., alternative modulation methods), the maximum conducted output power is the highest total transmit power occurring in any mode.

**Clause 15.247(b)(4) Maximum peak output power**

The conducted output power limit specified in paragraph (b) of this section is based on the use of antennas with directional gains that do not exceed 6 dBi. Except as shown in paragraph (c) of this section, if transmitting antennas of directional gain greater than 6 dBi are used, the conducted output power from the intentional radiator shall be reduced below the stated values in paragraphs (b)(1), (b)(2), and (b)(3) of this section, as appropriate, by the amount in dB that the directional gain of the antenna exceeds 6 dBi.

**Clause 15.247(c)(1) Fixed point-to-point Operation with directional antenna gains greater than 6 dBi**

- (i) Systems operating in the 2400–2483.5 MHz band that are used exclusively for fixed, point-to-point operations may employ transmitting antennas with directional gain greater than 6 dBi provided the maximum conducted output power of the intentional radiator is reduced by 1 dB for every 3 dB that the directional gain of the antenna exceeds 6 dBi.
- (ii) Systems operating in the 5725–5850 MHz band that are used exclusively for fixed, point-to-point operations may employ transmitting antennas with directional gain greater than 6 dBi without any corresponding reduction in transmitter conducted output power.
- (iii) Fixed, point-to-point operation, as used in paragraphs (c)(1)(i) and (c)(1)(ii) of this section, excludes the use of point-to-multipoint systems, omnidirectional applications, and multiple co-located intentional radiators transmitting the same information. The operator of the spread spectrum or digitally modulated intentional radiator or, if the equipment is professionally installed, the installer is responsible for ensuring that the system is used exclusively for fixed, point-to-point operations. The instruction manual furnished with the intentional radiator shall contain language in the installation instructions informing the operator and the installer of this responsibility.

**Test Results:** Pass

**Additional Observations:**

Transmit output power was measured while supply voltage was varied from 102 VAC to 138 VAC (85 % to 115 % of the nominal rated supply voltage). No change in transmit output power was observed.

The output RF power was measured on the antenna port 1 and 2 by means of a spectrum analyzer and following the 'Power Output Option 2, Method 1' procedure from the FCC guidelines for Measurement of Digital Transmission Systems operating under Section 15.247. The total output power equal to the summary of the output RF power was measured on the antenna port 1 and 2.



### 802.11b

#### Omni-directional antennas

Freq. (MHz)	G <sub>ANT</sub> (dBi)	Cable loss (dB)	G <sub>ANT+CABLE</sub> (dBi)	Antenna 1 Cond. (mW)	Antenna 2 Cond. (mW)	Total output power (dBm)	Limit (dBm)	Margin (dB)	EIRP (dBm)	Limit (dBm)	Margin (dB)
2412	5	0.5	4.5	255.59	259.61	27.12	30.00	2.88	31.62	36.00	4.38
2437	5	0.5	4.5	484.91	418.59	29.56	30.00	0.44	34.06	36.00	1.94
2462	5	0.5	4.5	241.08	227.73	26.71	30.00	3.29	31.21	36.00	4.79
2412	8	0.5	7.5	253.64	229.62	26.84	28.50	1.66	34.34	36.00	1.66
2437	8	0.5	7.5	352.03	311.93	28.22	28.50	0.28	35.72	36.00	0.28
2462	8	0.5	7.5	194.65	184.24	25.78	28.50	2.72	33.28	36.00	2.72

**Output power limit** = 30 dBm – (antenna gain – 6 dBi) [for antennas greater than 6 dBi]

Note: antenna gain considered as a combination of the actual antenna gain with the cable.

#### Directional antennas

Freq. (MHz)	G <sub>ANT</sub> (dBi)	Cable loss (dB)	G <sub>ANT+CABLE</sub> (dBi)	Antenna 1 Cond. (mW)	Antenna 2 Cond. (mW)	Total output power (dBm)	Limit (dBm)	Margin (dB)	EIRP (dBm)
2412	8	0.5	7.5	253.64	229.62	26.84	29.50	2.66	34.34
2437	8	0.5	7.5	352.03	311.93	28.22	29.50	1.28	35.72
2462	8	0.5	7.5	241.08	227.73	26.71	29.50	2.79	34.21
2412	17	0.5	16.5	143.28	135.26	24.45	26.50	2.05	40.95
2437	17	0.5	16.5	193.36	166.81	25.56	26.50	0.94	42.06
2462	17	0.5	16.5	142.64	137.02	24.47	26.50	2.03	40.97
2412	18	0.5	17.5	188.34	170.84	25.55	26.16	0.61	43.05
2437	18	0.5	17.5	193.36	166.81	25.56	26.16	0.60	43.06
2462	18	0.5	17.5	194.65	171.24	25.63	26.16	0.53	43.13

**Output power limit** = 30 dBm – (antenna gain – 6 dBi)/3 [for antennas greater than 6 dBi]

Note: antenna gain considered as a combination of the actual antenna gain with the cable.

#### Output power sample spectral plot:

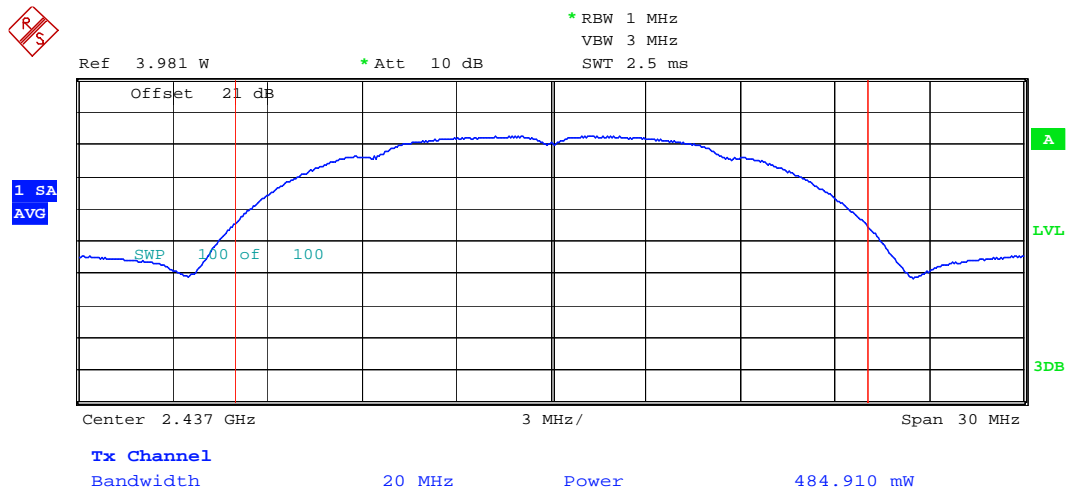

### 802.11g

#### Omni-directional antennas

Freq. (MHz)	G <sub>ANT</sub> (dBi)	Cable loss (dB)	G <sub>ANT+CABLE</sub> (dBi)	Antenna 1 Cond. (mW)	Antenna 2 Cond. (mW)	Total output power (dBm)	Limit (dBm)	Margin (dB)	EIRP (dBm)	Limit (dBm)	Margin (dB)
2412	5	0.5	4.5	124.07	108.83	23.67	30.00	6.33	28.17	36.00	7.83
2437	5	0.5	4.5	322.07	304.91	27.97	30.00	2.03	32.47	36.00	3.53
2462	5	0.5	4.5	88.69	83.53	22.36	30.00	7.64	26.86	36.00	9.14
2412	8	0.5	7.5	71.49	68.08	21.45	28.50	7.05	28.95	36.00	7.05
2437	8	0.5	7.5	322.07	304.91	27.97	28.50	0.53	35.47	36.00	0.53
2462	8	0.5	7.5	88.69	83.53	22.36	28.50	6.14	29.86	36.00	6.14

**Output power limit** = 30 dBm – (antenna gain – 6 dBi) [for antennas greater than 6 dBi]

Note: antenna gain considered as a combination of the actual antenna gain with the cable.

#### Directional antennas

Freq. (MHz)	G <sub>ANT</sub> (dBi)	Cable loss (dB)	G <sub>ANT+CABLE</sub> (dBi)	Antenna 1 Cond. (mW)	Antenna 2 Cond. (mW)	Total output power (dBm)	Limit (dBm)	Margin (dB)	EIRP (dBm)
2412	8	0.5	7.5	81.12	79.02	22.04	29.50	7.46	29.54
2437	8	0.5	7.5	156.96	141.01	24.74	29.50	4.76	32.24
2462	8	0.5	7.5	79.30	68.53	21.69	29.50	7.81	29.19
2412	17	0.5	16.5	32.64	31.64	18.08	26.50	8.42	34.58
2437	17	0.5	16.5	39.17	34.05	18.64	26.50	7.86	35.14
2462	17	0.5	16.5	40.84	37.65	18.95	26.50	7.55	35.45
2412	18	0.5	17.5	124.07	108.83	23.67	26.16	2.49	41.17
2437	18	0.5	17.5	124.40	113.63	23.76	26.16	2.40	41.26
2462	18	0.5	17.5	88.69	83.53	22.36	26.16	3.80	39.86

**Output power limit** = 30 dBm – (antenna gain – 6 dBi)/3 [for antennas greater than 6 dBi]

Note: antenna gain considered as a combination of the actual antenna gain with the cable.

#### Output power sample spectral plot:

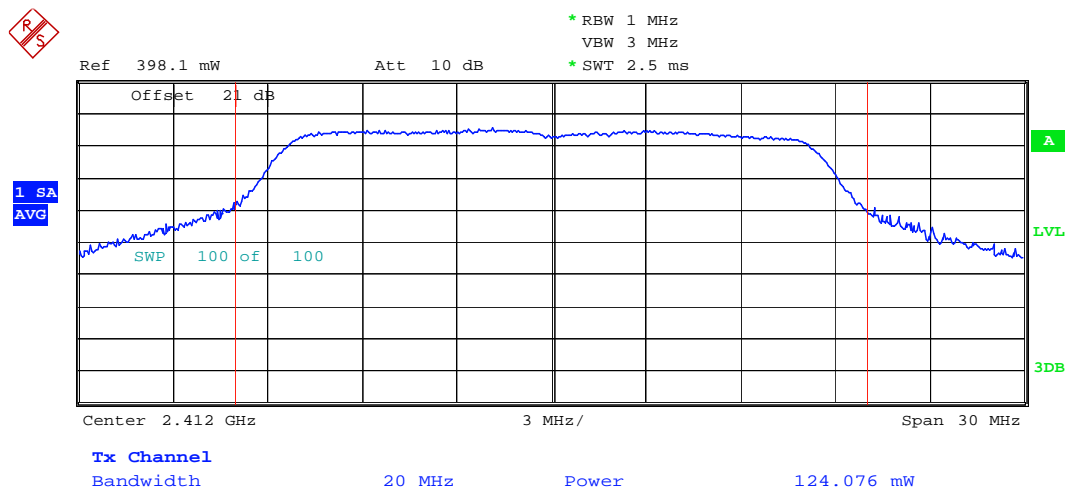

### 802.11n

#### Omni-directional antennas

Freq. (MHz)	G <sub>ANT</sub> (dBi)	Cable loss (dB)	G <sub>ANT+CABLE</sub> (dBi)	Antenna 1 Cond. (mW)	Antenna 2 Cond. (mW)	Total output power (dBm)	Limit (dBm)	Margin (dB)	EIRP (dBm)	Limit (dBm)	Margin (dB)
2412	5	0.5	4.5	69.60	65.94	21.32	30.00	8.68	25.82	36.00	10.18
2437	5	0.5	4.5	315.49	307.19	27.94	30.00	2.06	32.44	36.00	3.56
2462	5	0.5	4.5	121.30	115.46	23.74	30.00	6.26	28.24	36.00	7.76
2412	8	0.5	7.5	49.49	45.47	19.77	28.50	8.73	27.27	36.00	8.73
2437	8	0.5	7.5	315.49	307.19	27.94	28.50	0.56	35.44	36.00	0.56
2462	8	0.5	7.5	76.50	67.96	21.59	28.50	6.91	29.09	36.00	6.91

**Output power limit** = 30 dBm – (antenna gain – 6 dBi) [for antennas greater than 6 dBi]

Note: antenna gain considered as a combination of the actual antenna gain with the cable.

#### Directional antennas

Freq. (MHz)	G <sub>ANT</sub> (dBi)	Cable loss (dB)	G <sub>ANT+CABLE</sub> (dBi)	Antenna 1 Cond. (mW)	Antenna 2 Cond. (mW)	Total output power (dBm)	Limit (dBm)	Margin (dB)	EIRP (dBm)
2412	8	0.5	7.5	69.60	65.94	21.32	29.50	8.18	28.82
2437	8	0.5	7.5	153.28	151.00	24.83	29.50	4.67	32.33
2462	8	0.5	7.5	76.50	67.96	21.59	29.50	7.91	29.09
2412	17	0.5	16.5	26.20	24.34	17.03	26.50	9.47	33.53
2437	17	0.5	16.5	37.71	32.43	18.46	26.50	8.04	34.96
2462	17	0.5	16.5	39.61	34.47	18.69	26.50	7.81	35.19
2412	18	0.5	17.5	114.72	114.04	23.59	26.16	2.57	41.09
2437	18	0.5	17.5	122.34	109.78	23.65	26.16	2.51	41.15
2462	18	0.5	17.5	86.09	78.09	22.15	26.16	4.01	39.65

**Output power limit** = 30 dBm – (antenna gain – 6 dBi)/3 [for antennas greater than 6 dBi]

Note: antenna gain considered as a combination of the actual antenna gain with the cable.

#### Output power sample spectral plot:

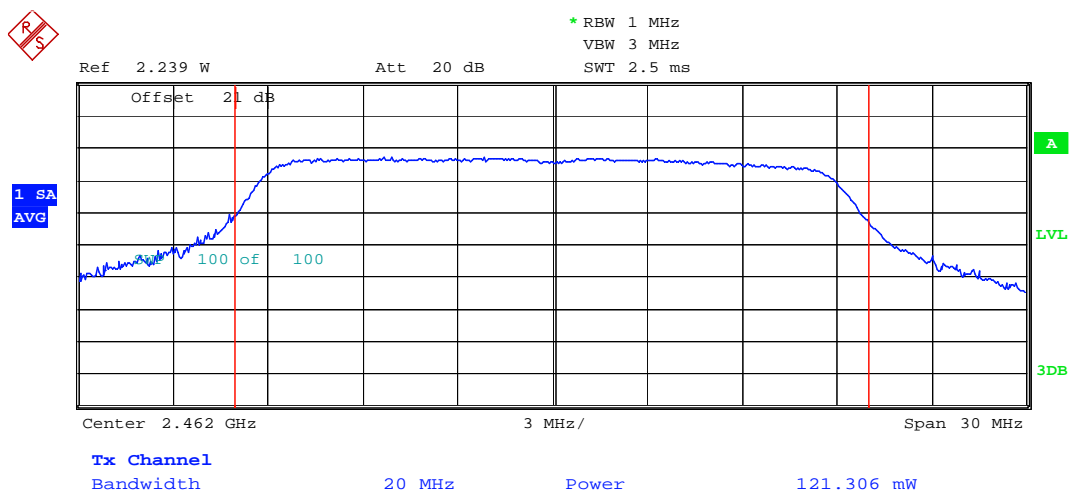

**Clause 15.247(d) Conducted Spurious Emissions**

In any 100 kHz bandwidth outside the frequency band in which the spread spectrum or digitally modulated intentional radiator is operating, the radio frequency power that is produced by the intentional radiator shall be at least 20 dB below that in the 100 kHz bandwidth within the band that contains the highest level of the desired power, based on either an RF conducted or a radiated measurement, provided the transmitter demonstrates compliance with the peak conducted power limits. If the transmitter complies with the conducted power limits based on the use of RMS averaging over a time interval, as permitted under paragraph (b)(3) of this section, the attenuation required under this paragraph shall be 30 dB instead of 20 dB. Attenuation below the general limits specified in §15.209(a) is not required. In addition, radiated emissions, which fall in the restricted bands, as defined in §15.205(a), must also comply with the radiated emission limits specified in §15.209(a) (see §15.205(c)).

**Test Results:** Pass

**Additional Observations:**

The Spectrum was searched from 30 MHz to 10<sup>th</sup> harmonics for low (2412 MHz), mid (2437 MHz) and high (2462 MHz) carrier frequencies.

All measurements for spurious emissions were performed conducted using a Spectrum analyzer with Peak Detector with 100 kHz/300 kHz RBW/VBW. The spurious emissions were measured individually on antenna port 1 and 2, and combined with antenna port 1 and 2 by using a RF combiner.

Only the worst-case test results are provided.

**802.11b**

**Channel 2437 MHz at antenna port 1**

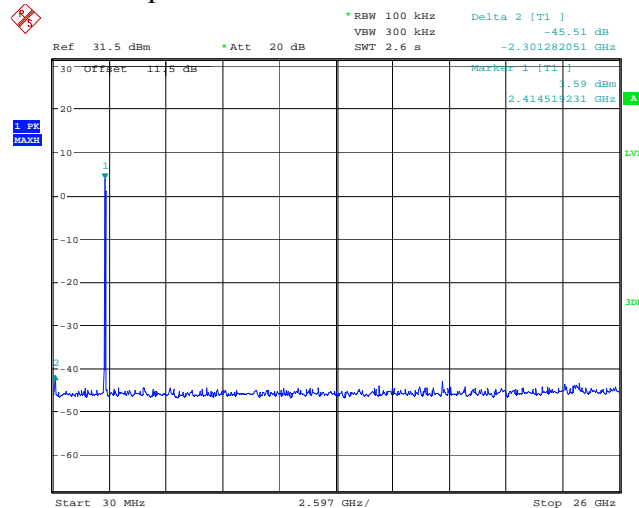

Date: 21.JAN.2010 11:58:15

**802.11g**  
 Channel 2412 MHz at antenna port 1

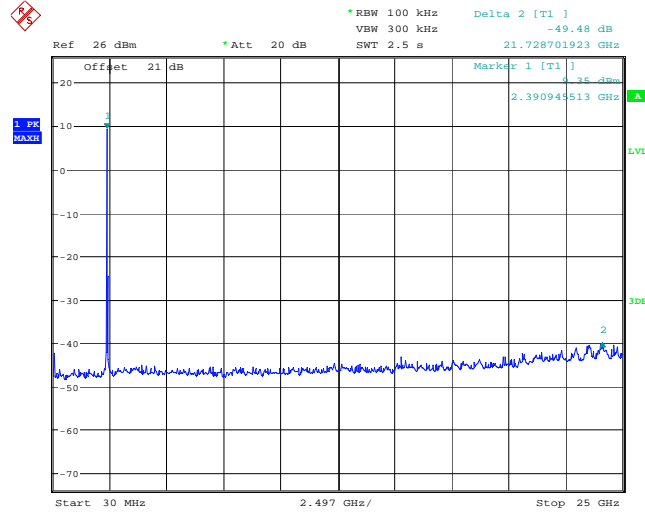

Date: 21.JAN.2010 09:43:36

**802.11n**  
 Channel 2437 MHz at antenna port 1

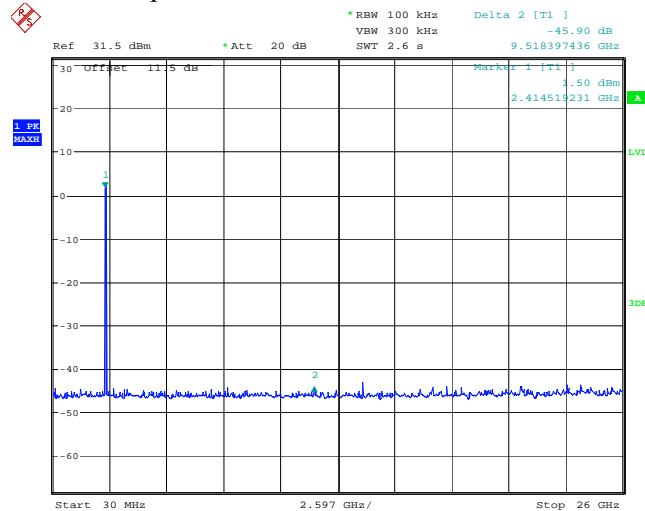

Date: 21.JAN.2010 12:01:17

There were no additional emissions or change in existing emissions when both the 2.4 GHz radio and 5 GHz radios operated simultaneously

Band edges measurements:

Lower band edge (measured on antenna port 1)

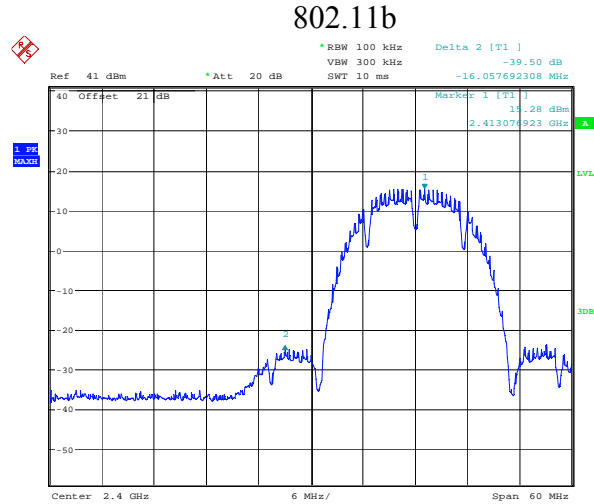

Date: 21.JAN.2010 10:38:47

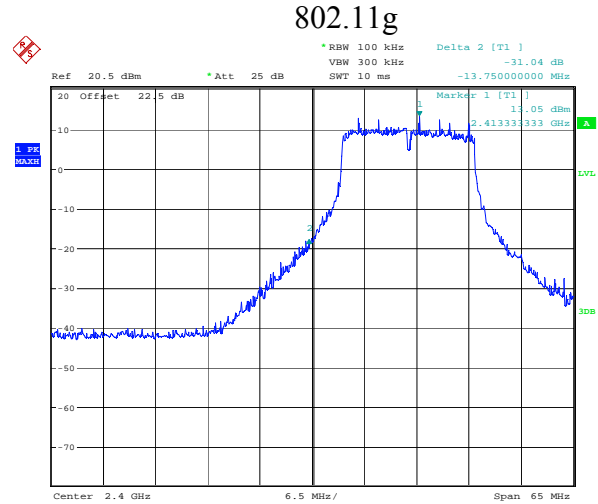

Date: 3.FEB.2010 08:36:20

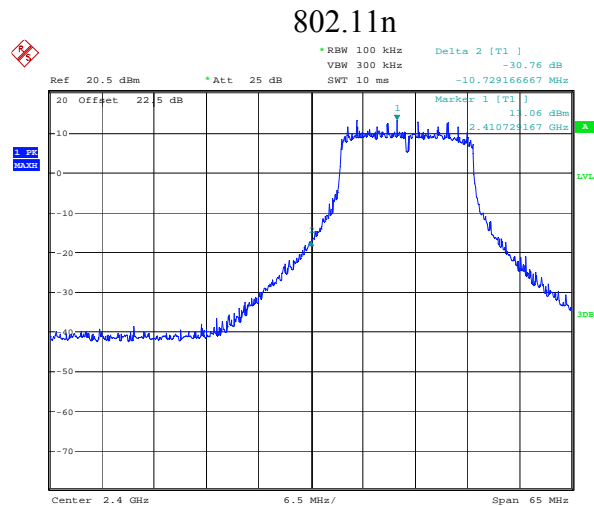

Date: 3.FEB.2010 08:35:04

Lower band edge results:

802.11b

Minimum attenuation below the fundamental is 39.50 dB

802.11g

Minimum attenuation below the fundamental is 31.04 dB

802.11n:

Minimum attenuation below the fundamental is 30.76 dB

Upper band edge (measured on antenna port 1)

802.11b

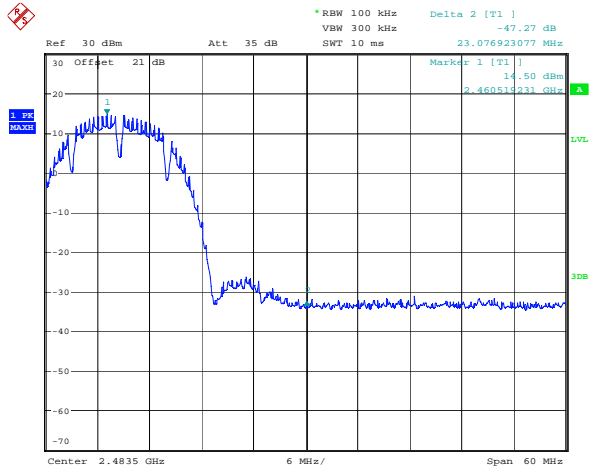

Date: 28.JAN.2010 15:05:53

802.11g

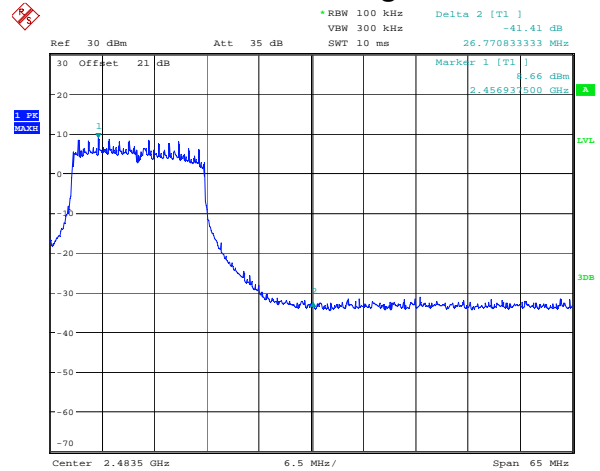

Date: 28.JAN.2010 15:45:55

802.11n

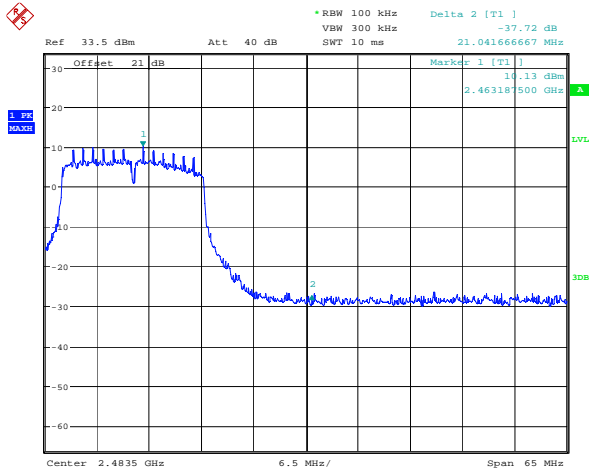

Date: 28.JAN.2010 16:22:08

Upper band edge results:

802.11b

Minimum attenuation below the fundamental is 47.27 dB

802.11g

Minimum attenuation below the fundamental is 41.41 dB

802.11n:

Minimum attenuation below the fundamental is 37.72 dB

---

**Clause 15.247(e) Power Spectral Density for Digitally Modulated Devices**

For digitally modulated systems, the power spectral density conducted from the intentional radiator to the antenna shall not be greater than 8 dBm in any 3 kHz band during any time interval of continuous transmission. This power spectral density shall be determined in accordance with the provisions of paragraph (b) of this section. The same method of determining the conducted output power shall be used to determine the power spectral density.

**Test Results:** Pass

**Additional Observations:**

The Power Spectral Density was measured on the antenna port 1 and 2 individually by means of a spectrum analyzer and following procedure described in 'PSD Option 1' in FCC guidelines for Measurement of Digital Transmission Systems operating under Section 15.247. The total PSD equal to the summary of the PSD was measured on the antenna port 1 and 2.

Only the worst-case test results are provided.





**Nemko Canada Inc.**

Report Number: 140724-1TRFWL

Specification: FCC Part 15 Subpart C, 15.247

**802.11b**

Freq. (MHz)	Antenna 1 Cond. (mW/3 kHz)	Antenna 2 Cond. (mW/3 kHz)	Total PSD Cond. (dBm/3 kHz)	Limit (dBm/3 kHz)	Margin (dB)
2412	1.910	1.693	5.56	8.00	2.44
2437	2.079	2.786	6.87	8.00	1.13
2462	1.704	1.413	4.94	8.00	3.06

PSD spectral plots samples:  
Antenna port 1

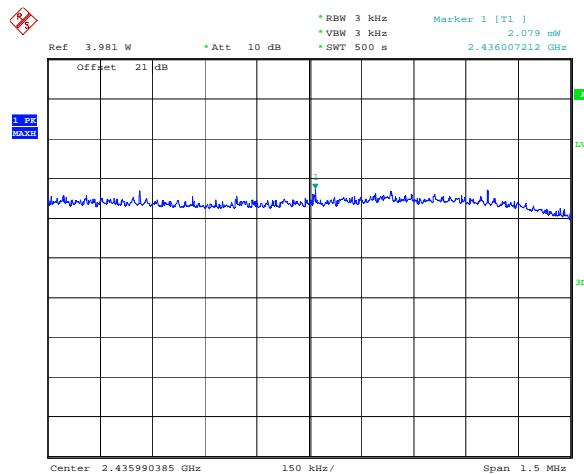
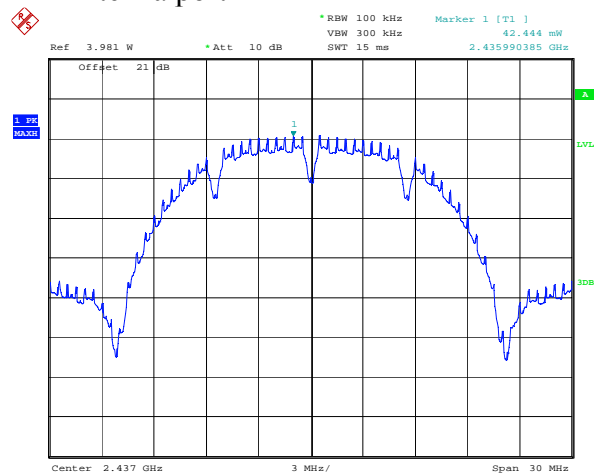

Date: 26.JAN.2010 13:56:13

Date: 26.JAN.2010 14:18:10

Antenna port 2

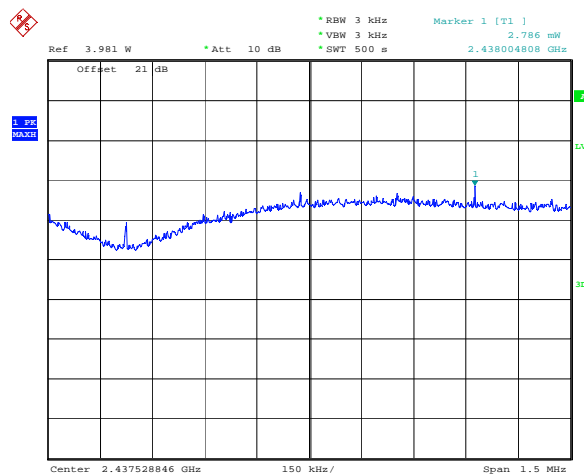
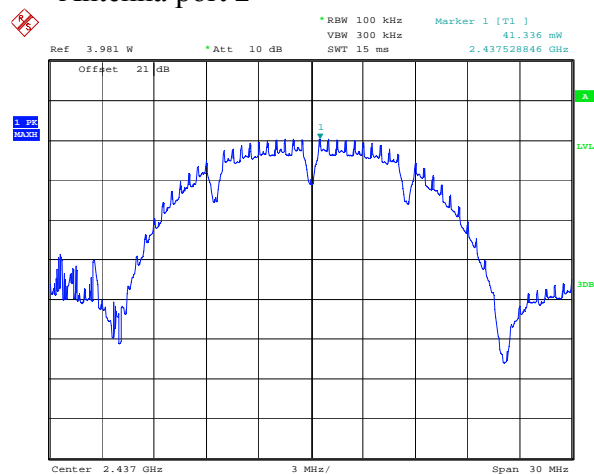

Date: 26.JAN.2010 14:26:54

Date: 26.JAN.2010 14:44:34



Nemko Canada Inc.

Report Number: 140724-1TRFWL

Specification: FCC Part 15 Subpart C, 15.247

802.11g

Freq. (MHz)	Antenna 1 Cond. (mW/3 kHz)	Antenna 2 Cond. (mW/3 kHz)	Total PSD Cond. (dBm/3 kHz)	Limit (dBm/3 kHz)	Margin (dB)
2412	0.392	0.398	-1.02	8.00	9.02
2437	1.036	0.984	3.05	8.00	4.95
2462	0.422	0.373	-0.99	8.00	8.99

PSD spectral plots samples: Antenna port 1

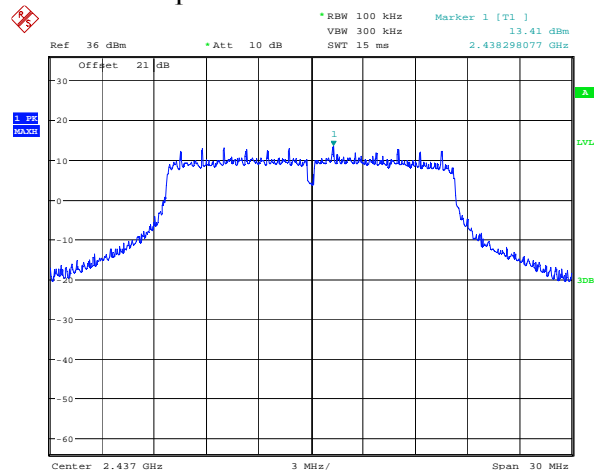

Date: 26.JAN.2010 13:49:34

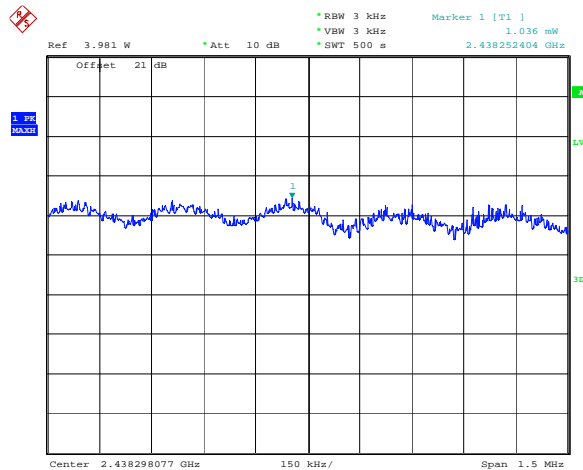

Date: 26.JAN.2010 13:54:24

Antenna port 2

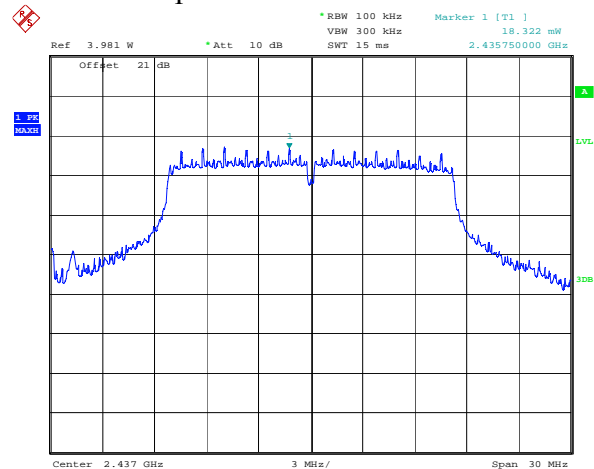

Date: 26.JAN.2010 13:38:37

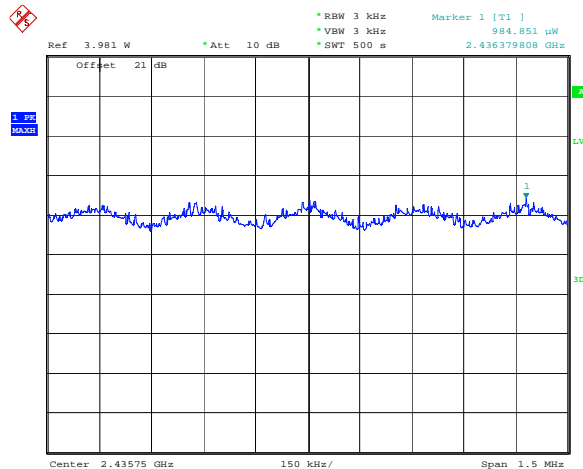

Date: 26.JAN.2010 13:47:57



**Nemko Canada Inc.**

Report Number: 140724-1TRFWL

Specification: FCC Part 15 Subpart C, 15.247

**802.11n**

Freq. (MHz)	Antenna 1 Cond. (mW/3 kHz)	Antenna 2 Cond. (mW/3 kHz)	Total PSD Cond. (dBm/3 kHz)	Limit (dBm/3 kHz)	Margin (dB)
2412	0.366	0.326	-1.59	8.00	9.59
2437	0.873	0.888	2.45	8.00	5.55
2462	0.487	0.409	-0.47	8.00	8.47

PSD spectral plots samples:

**Antenna port 1**

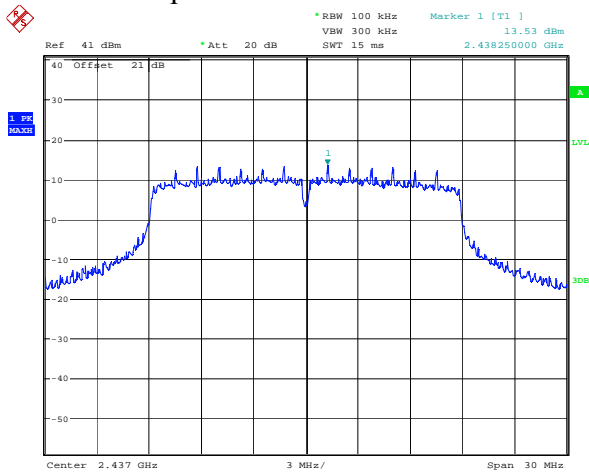

Date: 21.JAN.2010 12:11:55

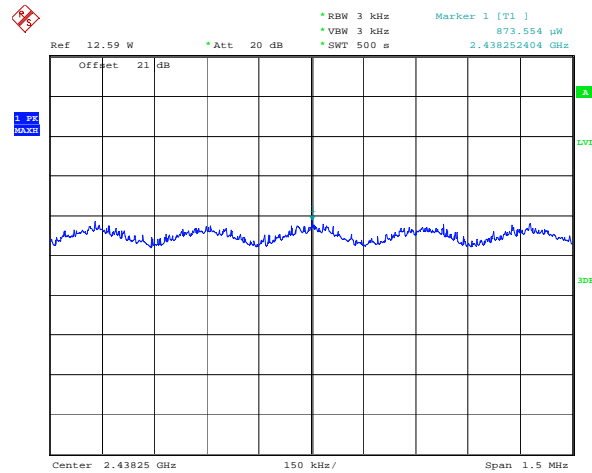

Date: 21.JAN.2010 12:22:19

**Antenna port 2**

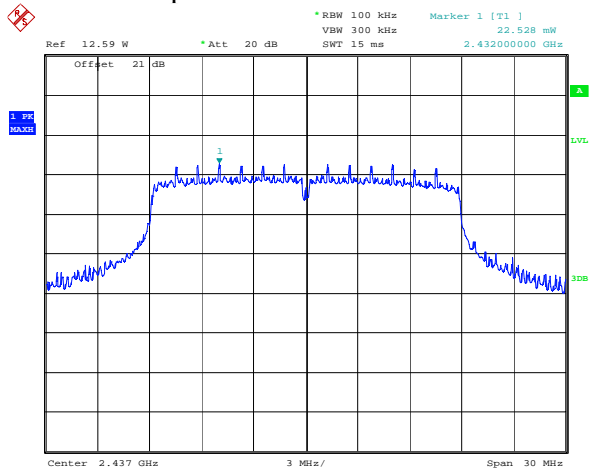

Date: 21.JAN.2010 12:23:38

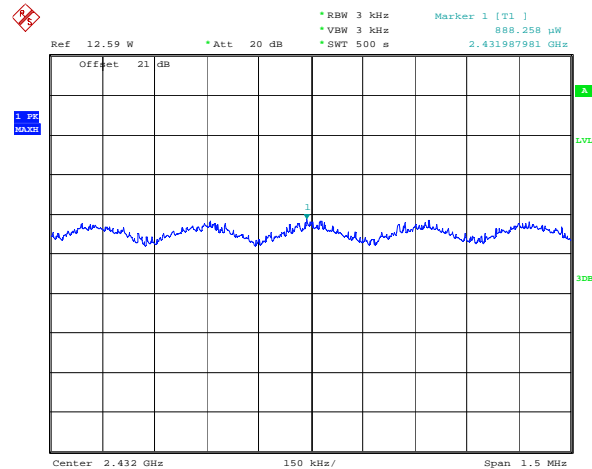

Date: 21.JAN.2010 12:42:42

## Appendix B : Setup Photographs

### Conducted Emissions Setup:

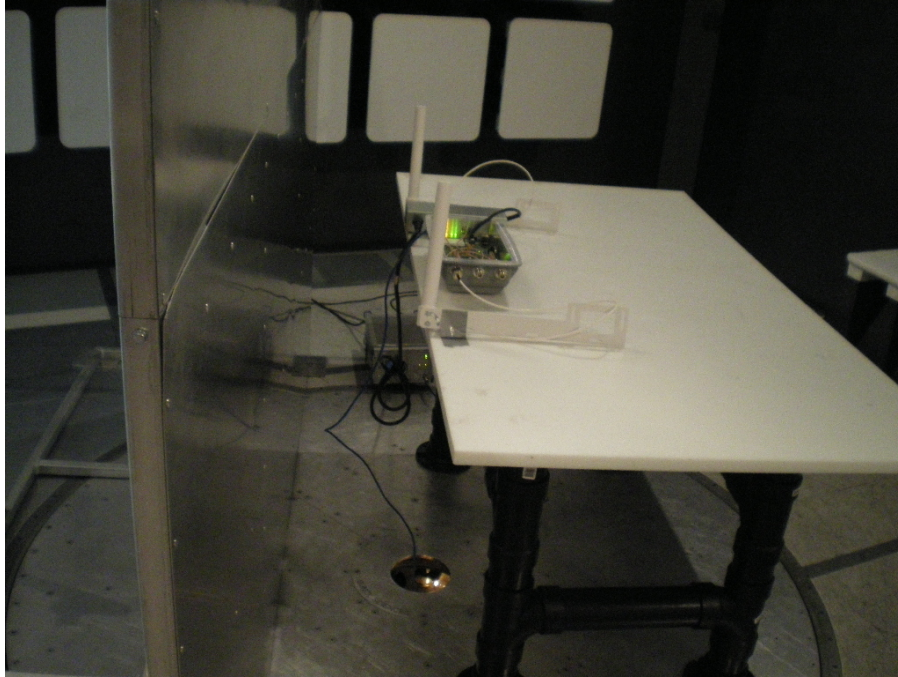

### Spurious Emissions Setup:

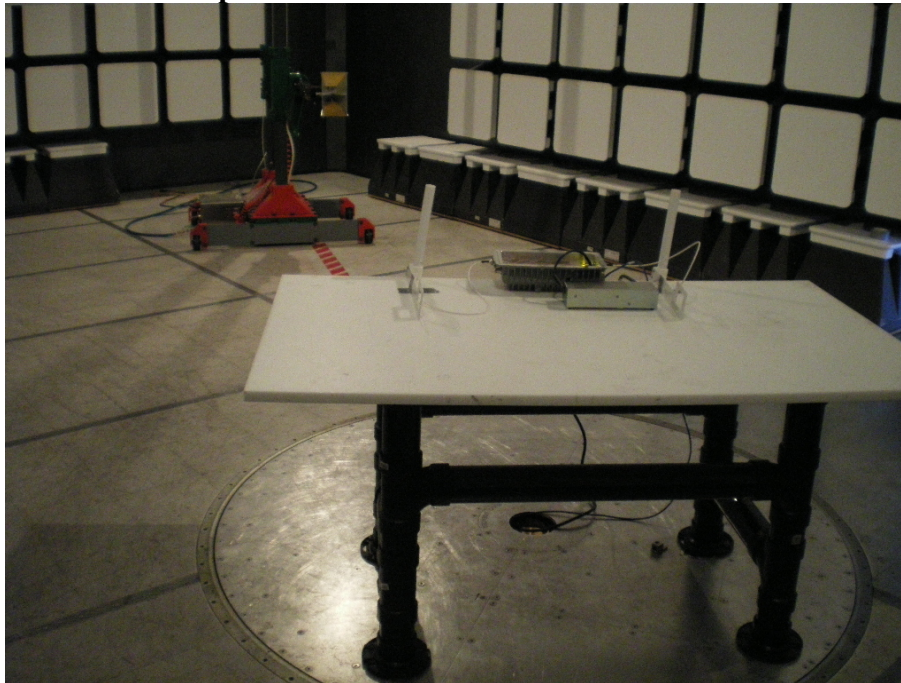

## Appendix C : Block Diagram of Test Setups

### Radiated Emissions above 30 MHz Test Site

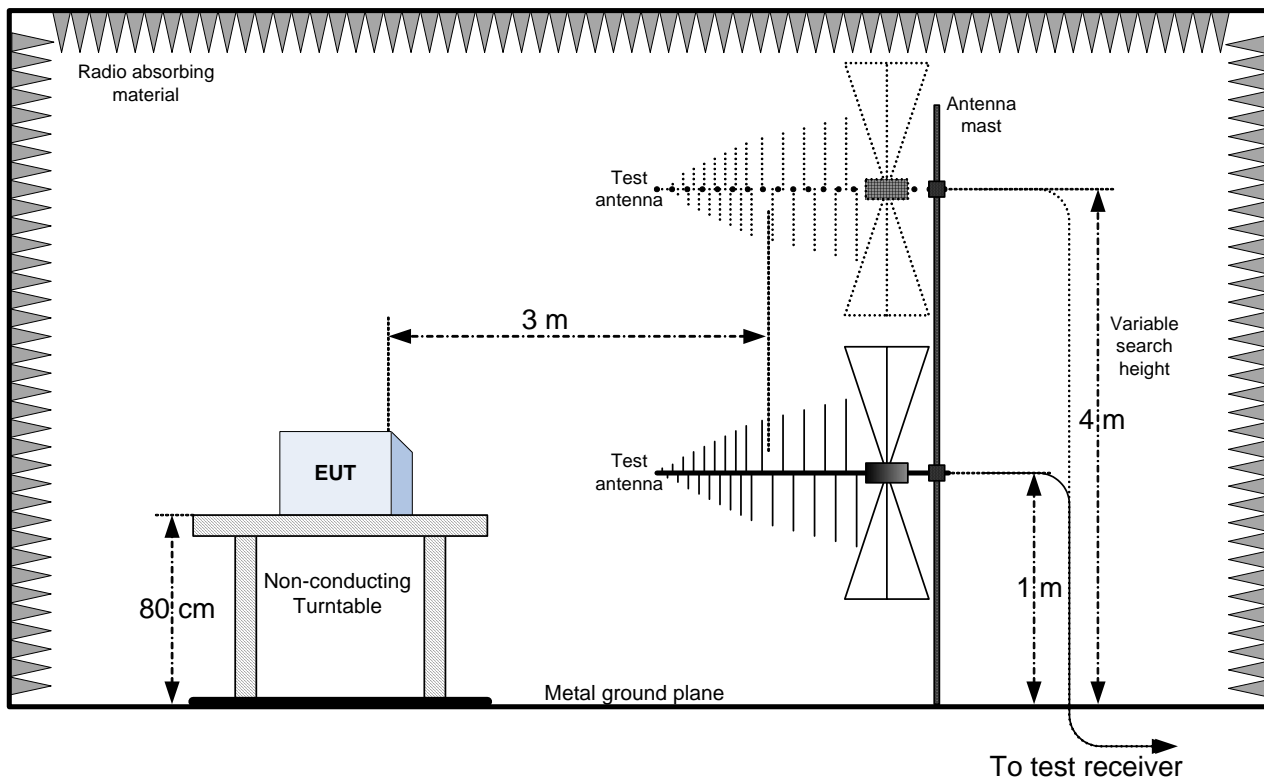

### Conducted Emissions Test Site

