



FCC RF Test Report

APPLICANT : TCT Mobile Limited
EQUIPMENT : GSM Quad-band / UMTS Quad-band / LTE six bands mobile phone
BRAND NAME : Alcatel
MODEL NAME : 6039S
FCC ID : RAD547
STANDARD : FCC 47 CFR Part 2, 22(H), 24(E), 27(L)
CLASSIFICATION : PCS Licensed Transmitter Held to Ear (PCE)

The product was received on Mar. 31, 2015 and testing was completed on Jun. 04, 2015. We, SPORTON INTERNATIONAL (KUNSHAN) INC., would like to declare that the tested sample has been evaluated in accordance with the test procedures given in ANSI / TIA / EIA-603-C-2004 and has been in compliance with the applicable technical standards.

The test results in this report apply exclusively to the tested model / sample. Without written approval of SPORTON INTERNATIONAL (KUNSHAN) INC., the test report shall not be reproduced except in full.

Reviewed by: Joseph Lin / Supervisor

Approved by: Jones Tsai / Manager



SPORTON INTERNATIONAL (KUNSHAN) INC.
No. 3-2, PingXiang Road, Kunshan, Jiangsu Province, P. R. China



TABLE OF CONTENTS

REVISION HISTORY..... 3

SUMMARY OF TEST RESULT 4

1 GENERAL DESCRIPTION 5

 1.1 Applicant..... 5

 1.2 Manufacturer 5

 1.3 Product Feature of Equipment Under Test 5

 1.4 Product Specification subjective to this standard..... 6

 1.5 Accessories and Support Equipment 7

 1.6 Modification of EUT 8

 1.7 Maximum ERP/EIRP Power, Frequency Tolerance, and Emission Designator 8

 1.8 Testing Location 9

 1.9 Applicable Standards 9

2 TEST CONFIGURATION OF EQUIPMENT UNDER TEST 10

 2.1 Test Mode..... 10

 2.2 Connection Diagram of Test System 15

 2.3 Support Unit used in test configuration 16

 2.4 Measurement Results Explanation Example 16

3 TEST RESULT 17

 3.1 Conducted Output Power Measurement..... 17

 3.2 Peak-to-Average Ratio 19

 3.3 Effective Radiated Power and Effective Isotropic Radiated Power Measurement 35

 3.4 99% Occupied Bandwidth and 26dB Bandwidth Measurement..... 39

 3.5 Band Edge Measurement..... 63

 3.6 Conducted Spurious Emission Measurement..... 78

 3.7 Field Strength of Spurious Radiation Measurement 133

 3.8 Frequency Stability Measurement..... 156

4 LIST OF MEASURING EQUIPMENT 162

5 UNCERTAINTY OF EVALUATION 163

APPENDIX A. SETUP PHOTOGRAPHS

APPENDIX B. PRODUCT EQUALITY DECLARATION



REVISION HISTORY

REPORT NO.	VERSION	DESCRIPTION	ISSUED DATE
FG511303-06A	Rev. 01	This is a variant product of 6039A. According to the product equality declaration as Appendix B which is provided by client, for GSM850/1900, WCDMA Band II/V, re-test the conducted power, ERP/EIRP, RSE, add L/H channel test for CSE, and full test for the new band WCDMA Band IV, all other test cases were performed on original report which can be referred to Sporton report number FG511303A (Model name: 6039A; FCC ID: RAD544).	Jun. 12, 2015



SUMMARY OF TEST RESULT

Report Section	FCC Rule	Description	Limit	Result	Remark
3.1	§2.1046	Conducted Output Power	Reporting Only	PASS	-
3.2	§24.232(d)	Peak-to-Average Ratio	< 13 dB	PASS	-
3.3	§22.913(a)(2)	Effective Radiated Power	< 7 Watts	PASS	-
	§24.232(c)	Equivalent Isotropic Radiated Power	< 2 Watts	PASS	-
	§27.50(d)(4)	Equivalent Isotropic Radiated Power	< 1 Watts	PASS	-
3.4	§2.1049 §22.917(b) §24.238(b) §27.53(g)	Occupied Bandwidth	Reporting Only	PASS	-
3.5	§2.1051 §22.917(a) §24.238(a) §27.53(h)	Band Edge Measurement	< 43+10log ₁₀ (P[Watts])	PASS	-
3.6	§2.1051 §22.917(a) §24.238(a) §27.53(h)	Conducted Emission	< 43+10log ₁₀ (P[Watts])	PASS	-
3.7	§2.1053 §22.917(a) §24.238(a) §27.53(h)	Field Strength of Spurious Radiation	< 43+10log ₁₀ (P[Watts])	PASS	Under limit 28.94 dB at 7401.00 MHz
3.8	§2.1055 §22.355	Frequency Stability for Temperature & Voltage	< 2.5 ppm for Part 22 Within Authorized Band	PASS	-
	§2.1055 §24.235 §27.54				



1 General Description

1.1 Applicant

TCT Mobile Limited

5F, C building, No. 232, Liang Jing Road ZhangJiang High-Tech Park, Pudong Area Shanghai, P.R. China. 201203

1.2 Manufacturer

TCT Mobile Limited

5F, C building, No. 232, Liang Jing Road ZhangJiang High-Tech Park, Pudong Area Shanghai, P.R. China. 201203

1.3 Product Feature of Equipment Under Test

Product Feature	
Equipment	GSM Quad-band / UMTS Quad-band / LTE six bands mobile phone
Brand Name	Alcatel
Model Name	6039S
FCC ID	RAD547
EUT supports Radios application	GSM/GPRS/EGPRS/WCDMA/HSPA/HSPA+ (Downlink Only)/DC-HSDPA/LTE/NFC/WLAN 2.4GHz 802.11b/g/n HT20/Bluetooth v3.0 + EDR / Bluetooth v4.1 LE
IMEI Code for 6039S	Conducted: 014322000050866 Radiated: 014369000011000 ERP/EIRP: 014369000047004
HW Version	SBA34D60000K
SW Version	SVN 01
EUT Stage	Identical Prototype

Remark: The above EUT's information was declared by manufacturer. Please refer to the specifications or user's manual for more detailed description.

1.4 Product Specification subjective to this standard

Product Specification subjective to this standard	
Tx Frequency	GSM850: 824.2 MHz ~ 848.8 MHz GSM1900: 1850.2 MHz ~ 1909.8MHz WCDMA Band V: 826.4 MHz ~ 846.6 MHz WCDMA Band IV : 1712.4 MHz ~ 1752.6 MHz WCDMA Band II: 1852.4 MHz ~ 1907.6 MHz
Rx Frequency	GSM850: 869.2 MHz ~ 893.8 MHz GSM1900: 1930.2 MHz ~ 1989.8 MHz WCDMA Band V: 871.4 MHz ~ 891.6 MHz WCDMA Band IV : 2112.4 MHz ~ 2152.6 MHz WCDMA Band II: 1932.4 MHz ~ 1987.6 MHz
Maximum Output Power to Antenna	GSM850 : 33.25 dBm GSM1900 : 29.60 dBm WCDMA Band V : 23.36 dBm WCDMA Band IV : 24.05 dBm WCDMA Band II : 22.29 dBm
Antenna Type	Fixed Internal Antenna
Type of Modulation	GSM: GMSK GPRS: GMSK EDGE: GMSK / 8PSK WCDMA : QPSK (Uplink) HSDPA/DC-HSDPA : QPSK (Uplink) HSUPA : QPSK (Uplink) HSPA+ : 16QAM (Downlink Only) DC-HSDPA : 64QAM

1.5 Accessories and Support Equipment

Specification of Accessory			
AC Adapter	Brand Name	ACE-Tenpao	Model Name UC11US
	Power Rating	I/P: 100-240Vac, 200mA, O/P: 5Vdc, 1000mA	
	P/N	CBA0058AG0C2	
Battery	Brand Name	ALCATEL onetouch	Model Name TLp020K2
	Power Rating	3.8Vdc, 2000mAh	
	P/N	CAC2000023C2	
USB Cable 1	Brand Name	ACE-Shenhua	Model Name CDA0000025C1
	Signal Line Type	1.10m shielded without core	
USB Cable 2	Brand Name	ACE-Juwei	Model Name CDA0000025C2
	Signal Line Type	1.10m shielded without core	
USB Cable 3	Brand Name	ACE-Juwei	Model Name CDA0000025C8
	Signal Line Type	1.10m shielded without core	
Earphone	Brand Name	ACE-JBL	Model Name J22C
	Signal Line Type	1.38m non-shielded without core	



1.6 Modification of EUT

No modifications are made to the EUT during all test items.

1.7 Maximum ERP/EIRP Power, Frequency Tolerance, and Emission Designator

FCC Rule	System	Type of Modulation	Maximum ERP/EIRP (W)	Frequency Tolerance (ppm)	Emission Designator
Part 22	GSM850 GSM	GMSK	1.7660	0.0287 ppm	246KGXW
Part 22	GSM850 EDGE class 8	8PSK	0.3802	0.0203 ppm	244KG7W
Part 22	WCDMA Band V RMC 12.2Kbps	QPSK	0.1652	0.0251 ppm	4M18F9W
Part 24	GSM1900 GSM	GMSK	1.9231	0.0106 ppm	246KGXW
Part 24	GSM1900 EDGE class 8	8PSK	0.6887	0.0133 ppm	250KG7W
Part 24	WCDMA Band II RMC 12.2Kbps	QPSK	0.4887	0.0122 ppm	4M18F9W
Part 27	WCDMA Band IV RMC 12.2Kbps	QPSK	0.6067	0.0150 ppm	4M18F9W



1.8 Testing Location

Test Site	SPORTON INTERNATIONAL (KUNSHAN) INC.		
Test Site Location	No. 3-2, PingXiang Road, Kunshan, Jiangsu Province, P. R. China TEL: +86-0512-5790-0158 FAX: +86-0512-5790-0958		
Test Site No.	Sporton Site No.		FCC Registration No.
	TH01-KS	03CH02-KS	418269

1.9 Applicable Standards

According to the specifications of the manufacturer, the EUT must comply with the requirements of the following standards:

- FCC 47 CFR Part 2, 22(H), 24(E), 27(L)
- ANSI / TIA / EIA-603-C-2004
- FCC KDB 971168 D01 Power Meas. License Digital Systems v02r02

Remark:

1. All test items were verified and recorded according to the standards and without any deviation during the test.
2. This EUT has also been tested and complied with the requirements of FCC Part 15, Subpart B, recorded in a separate test report.



2 Test Configuration of Equipment Under Test

2.1 Test Mode

Antenna port conducted and radiated test items were performed according to KDB 971168 D01 Power Meas. License Digital Systems v02r02 with maximum output power.

Radiated measurements were performed with rotating EUT in different three orthogonal test planes to find the maximum emission.

Radiated emissions were investigated as following frequency range:

1. 30 MHz to 10th harmonic for GSM850 and WCDMA Band V.
2. 30 MHz to 10th harmonic for WCDMA Band IV
3. 30 MHz to 10th harmonic for GSM1900 and WCDMA Band II.

All modes and data rates and positions were investigated.

Test modes are chosen to be reported as the worst case configuration below:

Test Modes		
Band	Radiated TCs	Conducted TCs
GSM 850	<ul style="list-style-type: none"> ■ GSM Link ■ EDGE class 8 Link 	<ul style="list-style-type: none"> ■ GSM Link ■ EDGE class 8 Link
GSM 1900	<ul style="list-style-type: none"> ■ GSM Link ■ EDGE class 8 Link 	<ul style="list-style-type: none"> ■ GSM Link ■ EDGE class 8 Link
WCDMA Band V	<ul style="list-style-type: none"> ■ RMC 12.2Kbps Link 	<ul style="list-style-type: none"> ■ RMC 12.2Kbps Link
WCDMA Band II	<ul style="list-style-type: none"> ■ RMC 12.2Kbps Link 	<ul style="list-style-type: none"> ■ RMC 12.2Kbps Link
WCDMA Band IV	<ul style="list-style-type: none"> ■ RMC 12.2Kbps Link 	<ul style="list-style-type: none"> ■ RMC 12.2Kbps Link

Note: According the functionality of the EUT, the maximum power levels are chosen to test all test cases listed in this report as the worst case configuration is when top acoustic receiver works.



Conducted Power Measurement Results:

<Full Power Mode>

Conducted Power (*Unit: dBm)						
Band	GSM850			GSM1900		
Channel	128	189	251	512	661	810
Frequency	824.2	836.4	848.8	1850.2	1880.0	1909.8
GSM	33.00	33.11	33.25	29.44	29.35	29.60
GPRS class 8	32.99	33.10	33.23	29.42	29.34	29.59
GPRS class 10	31.25	30.92	31.10	28.33	28.00	28.27
GPRS class 11	29.08	29.12	29.33	26.00	25.96	25.95
GPRS class 12	28.00	28.04	28.24	24.99	24.92	24.83
EGPRS class 8	25.57	25.55	25.65	25.81	25.75	25.89
EGPRS class 10	25.53	25.45	25.59	24.60	24.39	24.75
EGPRS class 11	23.70	23.64	23.70	22.91	22.84	23.00
EGPRS class 12	21.91	21.93	22.00	21.41	21.35	21.45



Conducted Power (*Unit: dBm)									
Band	WCDMA Band V			WCDMA Band II			WCDMA Band IV		
Channel	4132	4182	4233	9262	9400	9538	1312	1413	1513
Frequency	826.4	836.4	846.6	1852.4	1880.0	1907.6	1712.4	1732.6	1752.6
AMR 12.2Kbps	23.12	22.93	23.35	22.16	22.14	22.28	24.04	23.96	24.01
RMC 12.2Kbps	23.14	22.95	23.36	22.18	22.15	22.29	24.05	23.99	24.03
HSDPA Subtest-1	21.75	21.54	21.90	20.39	20.40	20.38	22.40	22.35	22.31
HSDPA Subtest-2	21.76	21.57	21.86	20.38	20.42	20.47	22.38	22.28	22.32
HSDPA Subtest-3	21.77	21.59	21.87	20.36	20.41	20.46	22.36	22.32	22.38
HSDPA Subtest-4	21.73	21.53	21.89	20.44	20.42	20.45	22.34	22.34	22.39
DC-HSDPA Subtest-1	21.69	21.54	21.83	20.35	20.30	20.43	22.43	22.26	22.47
DC-HSDPA Subtest-2	21.77	21.55	21.87	20.33	20.42	20.44	22.51	22.38	22.41
DC-HSDPA Subtest-3	21.76	21.51	21.86	20.32	20.32	20.49	22.50	22.42	22.40
DC-HSDPA Subtest-4	21.75	21.58	21.89	20.34	20.31	20.47	22.49	22.28	22.44
HSUPA Subtest-1	21.33	21.14	21.47	20.55	20.32	20.52	22.47	22.41	22.48
HSUPA Subtest-2	20.86	20.69	20.77	19.68	19.66	19.55	21.55	21.56	21.57
HSUPA Subtest-3	20.41	20.22	20.40	19.74	19.71	19.79	21.57	21.58	21.55
HSUPA Subtest-4	20.99	20.72	20.96	20.11	20.01	20.14	22.11	22.08	22.09
HSUPA Subtest-5	21.22	21.01	21.32	20.56	20.53	20.54	22.48	22.46	22.41



<Reduced Power Mode>:

Conducted Power (*Unit: dBm)						
Band	GSM850			GSM1900		
Channel	128	189	251	512	661	810
Frequency	824.2	836.4	848.8	1850.2	1880.0	1909.8
GSM	29.27	29.37	29.39	24.25	24.16	24.33
GPRS class 8	29.22	29.32	29.38	24.24	24.15	24.27
GPRS class 10	28.88	28.56	28.67	21.13	21.27	21.15
GPRS class 11	26.66	26.62	26.55	19.60	19.77	19.69
GPRS class 12	25.45	25.52	25.59	18.00	18.22	18.21
EGPRS class 8	25.61	25.58	25.61	24.07	24.01	24.02
EGPRS class 10	25.53	25.51	25.52	21.18	21.12	21.10
EGPRS class 11	23.73	23.70	23.72	19.52	19.48	19.63
EGPRS class 12	22.08	22.07	22.06	17.97	17.96	18.00



Conducted Power (*Unit: dBm)						
Band	WCDMA Band II			WCDMA Band IV		
Channel	9262	9400	9538	1312	1413	1513
Frequency	1852.4	1880.0	1907.6	1712.4	1732.6	1752.6
AMR 12.2Kbps	16.34	16.36	16.30	16.53	16.43	16.49
RMC 12.2Kbps	16.36	16.37	16.32	16.55	16.45	16.50
HSDPA Subtest-1	14.55	14.41	14.58	14.85	14.69	14.88
HSDPA Subtest-2	14.54	14.39	14.57	14.86	14.72	14.89
HSDPA Subtest-3	14.57	14.42	14.59	14.87	14.65	14.85
HSDPA Subtest-4	14.57	14.43	14.57	14.89	14.64	14.88
DC-HSDPA Subtest-1	14.37	14.43	14.51	14.89	14.74	14.86
DC-HSDPA Subtest-2	14.45	14.40	14.46	14.85	14.77	14.84
DC-HSDPA Subtest-3	14.38	14.42	14.48	14.83	14.75	14.77
DC-HSDPA Subtest-4	14.42	14.48	14.46	14.81	14.69	14.81
HSUPA Subtest-1	14.47	14.48	14.48	14.97	14.81	14.89
HSUPA Subtest-2	14.02	14.03	14.09	14.15	14.15	14.19
HSUPA Subtest-3	14.05	14.01	14.04	14.15	14.16	14.14
HSUPA Subtest-4	14.17	14.14	14.18	14.53	14.68	14.66
HSUPA Subtest-5	14.61	14.63	14.72	14.88	14.96	14.84

2.2 Connection Diagram of Test System

<22H/24E/27L Tx Mode>

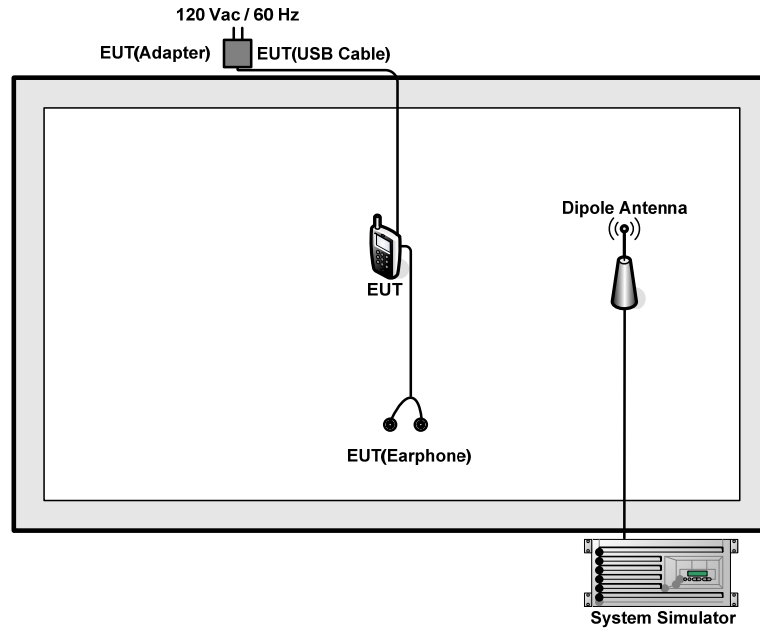



2.3 Support Unit used in test configuration

Item	Equipment	Trade Name	Model No.	FCC ID	Data Cable	Power Cord
1.	System Simulator	R&S	CMU 200	N/A	N/A	Unshielded, 1.8 m
2.	DC Power Supply	GW INSTEK	GPS-3030D	N/A	N/A	Unshielded, 1.8 m

2.4 Measurement Results Explanation Example

For all conducted test items:

The offset level is set in the spectrum analyzer to compensate the RF cable loss and attenuator factor between RF conducted output port and spectrum analyzer. With the offset compensation, the spectrum analyzer reading level will be exactly the RF output level.

The spectrum analyzer offset is derived from RF cable loss and attenuator factor.

$$\text{Offset} = \text{RF cable loss} + \text{attenuator factor}.$$

The following shows an offset computation example with RF cable loss 6.0 dB and a 10dB attenuator.

Example :

$$\begin{aligned} \text{Offset(dB)} &= \text{RF cable loss(dB)} + \text{attenuator factor(dB)}. \\ &= 6.0 + 10 = 16.0 \text{ (dB)} \end{aligned}$$

3 Test Result

3.1 Conducted Output Power Measurement

3.1.1 Description of the Conducted Output Power Measurement

A system simulator was used to establish communication with the EUT. Its parameters were set to enforce EUT transmitting at the maximum power. The measured power in the radio frequency on the transmitter output terminals shall be reported.

3.1.2 Measuring Instruments

The measuring equipment is listed in the section 4 of this test report.

3.1.3 Test Procedures

1. The transmitter output port was connected to the system simulator.
2. Set EUT at maximum power through system simulator.
3. Select lowest, middle, and highest channels for each band and different modulation.
4. Measure the maximum burst average power for GSM and maximum average power for other modulation signal.

3.1.4 Test Setup

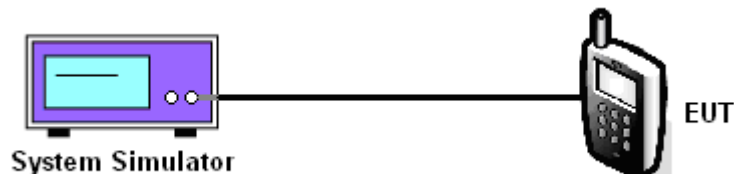



3.1.5 Test Result of Conducted Output Power

Cellular Band									
Modes	GSM850 (GSM)			GSM850 (EDGE class 8)			WCDMA Band V (RMC 12.2Kbps)		
Channel	128 (Low)	189 (Mid)	251 (High)	128 (Low)	189 (Mid)	251 (High)	4132 (Low)	4182 (Mid)	4233 (High)
Frequency (MHz)	824.2	836.4	848.8	824.2	836.4	848.8	826.4	836.4	846.6
Conducted Power (dBm)	33.00	33.11	33.25	25.57	25.55	25.65	23.14	22.95	23.36

PCS Band									
Modes	GSM1900 (GSM)			GSM1900 (EDGE class 8)			WCDMA Band II (RMC 12.2Kbps)		
Channel	512 (Low)	661 (Mid)	810 (High)	512 (Low)	661 (Mid)	810 (High)	9262 (Low)	9400 (Mid)	9538 (High)
Frequency (MHz)	1850.2	1880	1909.8	1850.2	1880	1909.8	1852.4	1880	1907.6
Conducted Power (dBm)	29.44	29.35	29.60	25.81	25.75	25.89	22.18	22.15	22.29

AWS Band			
Modes	WCDMA Band IV (RMC 12.2Kbps)		
Channel	1312 (Low)	1413 (Mid)	1513 (High)
Frequency (MHz)	1712.4	1732.6	1752.6
Conducted Power (dBm)	24.05	23.99	24.03

Note: Maximum burst average power for GSM, and maximum average power for WCDMA.

3.2 Peak-to-Average Ratio

3.2.1 Description of the PAR Measurement

The peak-to-average ratio (PAR) of the transmission may not exceed 13 dB.

3.2.2 Measuring Instruments

The measuring equipment is listed in the section 4 of this test report.

3.2.3 Test Procedures

1. The testing follows FCC KDB 971168 v02r02 Section 5.7.1.
2. The EUT was connected to the spectrum analyzer and system simulator via a power divider.
3. For GSM/EGPRS operating modes:
 - a. Set EUT in maximum power output.
 - b. Set the RBW = 1MHz, VBW = 3MHz, Peak detector on spectrum analyzer for first trace.
 - c. Set the RBW = 1MHz, VBW = 3MHz, RMS detector on spectrum analyzer for second trace.
 - d. The wanted burst signal is triggered by spectrum analyzer, and measured respectively the peak level and Mean level without burst-off time, after system simulator has synchronized with the spectrum analyzer.
4. For UMTS operating modes:
 - a. Set the CCDF (Complementary Cumulative Distribution Function) option on the spectrum analyzer.
 - b. The highest RF powers were measured and recorded the maximum PAPR level associated with a probability of 0.1 %.
5. Record the deviation as Peak to Average Ratio.

3.2.4 Test Setup

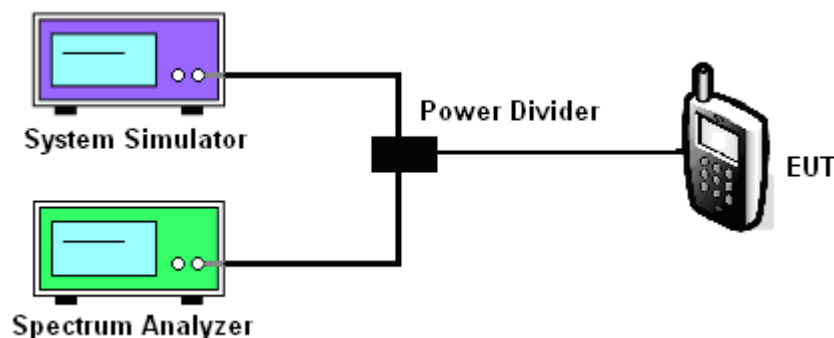

3.2.5 Test Result of Peak-to-Average Ratio

Cellular Band									
Modes	GSM850 (GSM)			GSM850 (EDGE class 8)			WCDMA Band V (RMC 12.2Kbps)		
Channel	128 (Low)	189 (Mid)	251 (High)	128 (Low)	189 (Mid)	251 (High)	4132 (Low)	4182 (Mid)	4233 (High)
Frequency (MHz)	824.2	836.4	848.8	824.2	836.4	848.8	826.4	836.4	846.6
Peak-to-Average Ratio (dB)	0.39	0.39	0.37	2.80	2.96	2.79	2.88	3.12	2.84

PCS Band									
Modes	GSM1900 (GSM)			GSM1900 (EDGE class 8)			WCDMA Band II (RMC 12.2Kbps)		
Channel	512 (Low)	661 (Mid)	810 (High)	512 (Low)	661 (Mid)	810 (High)	9262 (Low)	9400 (Mid)	9538 (High)
Frequency (MHz)	1850.2	1880	1909.8	1850.2	1880	1909.8	1852.4	1880	1907.6
Peak-to-Average Ratio (dB)	0.37	0.37	0.37	2.86	2.78	2.95	2.80	2.44	2.68

AWS Band			
Modes	WCDMA Band IV (RMC 12.2Kbps)		
Channel	1312 (Low)	1413 (Mid)	1513 (High)
Frequency (MHz)	1712.4	1732.6	1752.6
Peak-to-Average Ratio (dB)	2.72	2.96	2.88



3.2.6 Test Result (Plots) of Peak-to-Average Ratio

Band :	GSM 850	Test Mode :	GSM Link (GMSK)
---------------	---------	--------------------	-----------------

Peak-to-Average Ratio on Channel 128 (824.2 MHz)

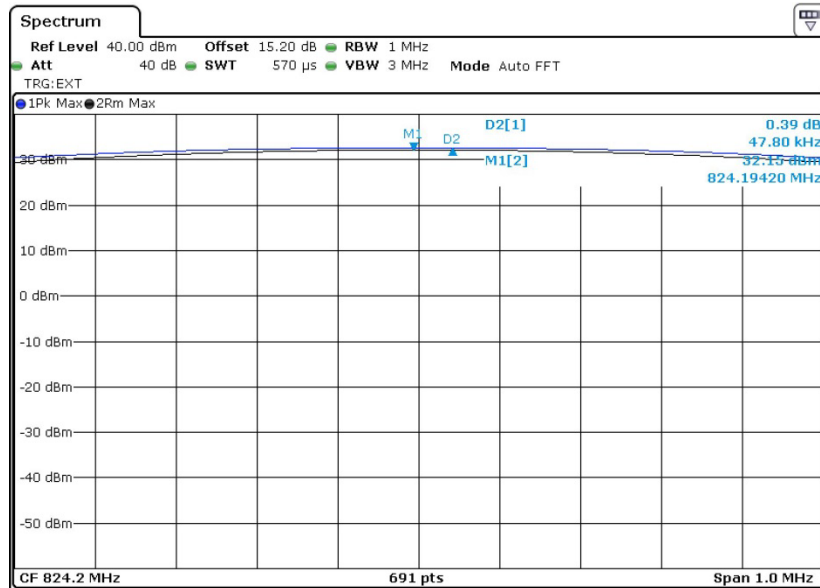

Peak-to-Average Ratio on Channel 189 (836.4 MHz)

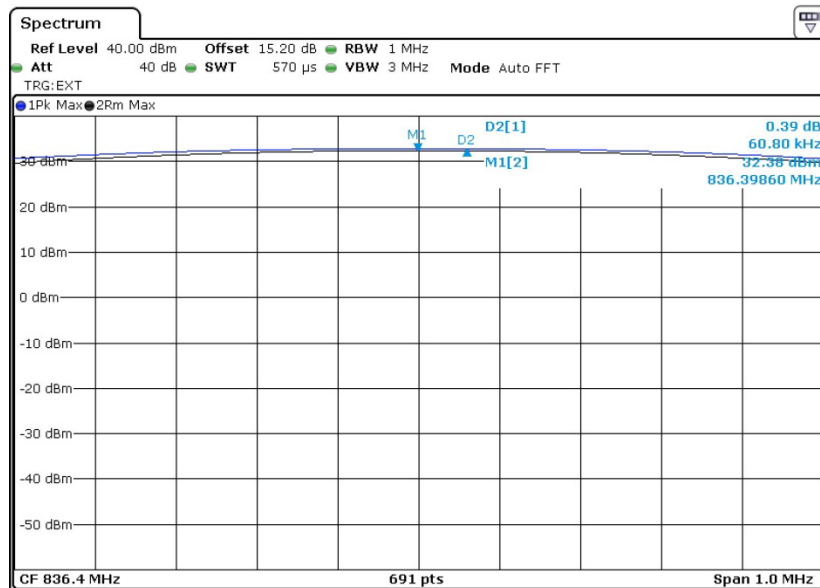



Peak-to-Average Ratio on Channel 251 (848.8 MHz)

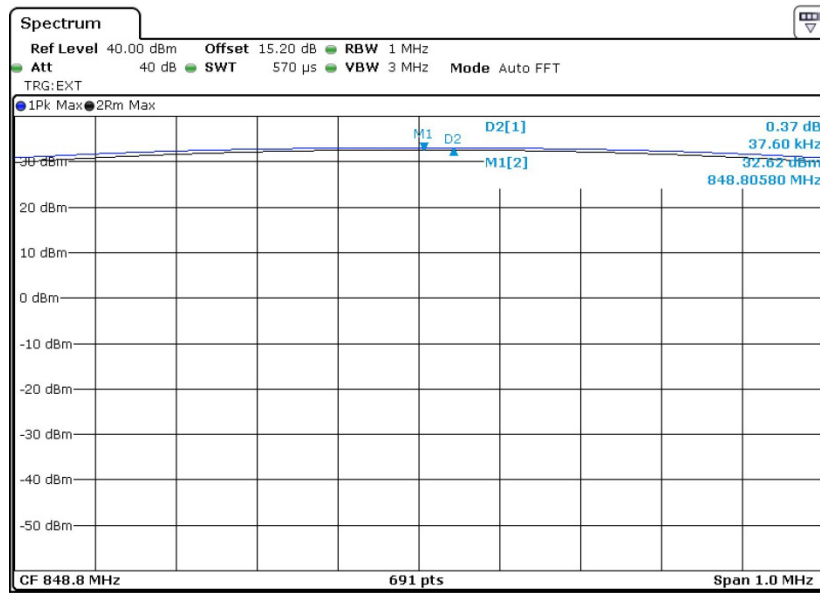



Band :	GSM 850	Test Mode :	EDGE class 8 Link (8PSK)
---------------	---------	--------------------	--------------------------

Peak-to-Average Ratio on Channel 128 (824.2 MHz)

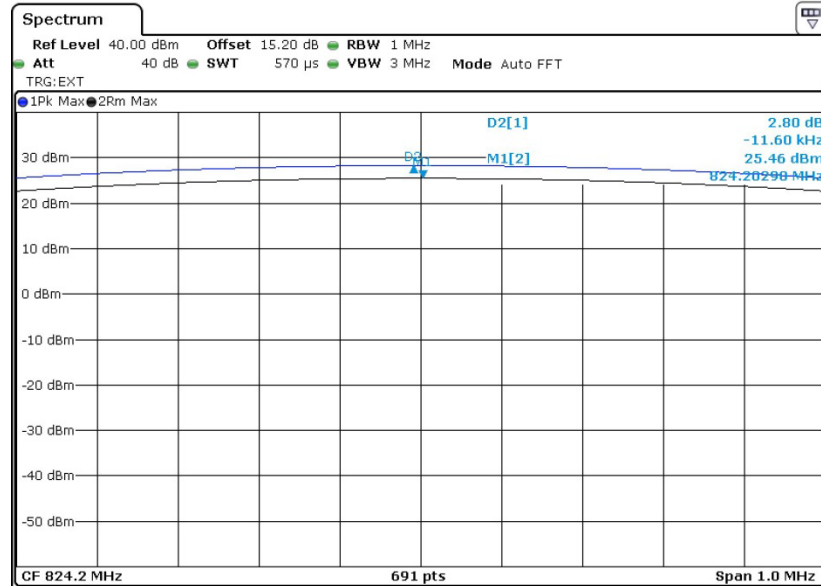

Peak-to-Average Ratio on Channel 189 (836.4 MHz)

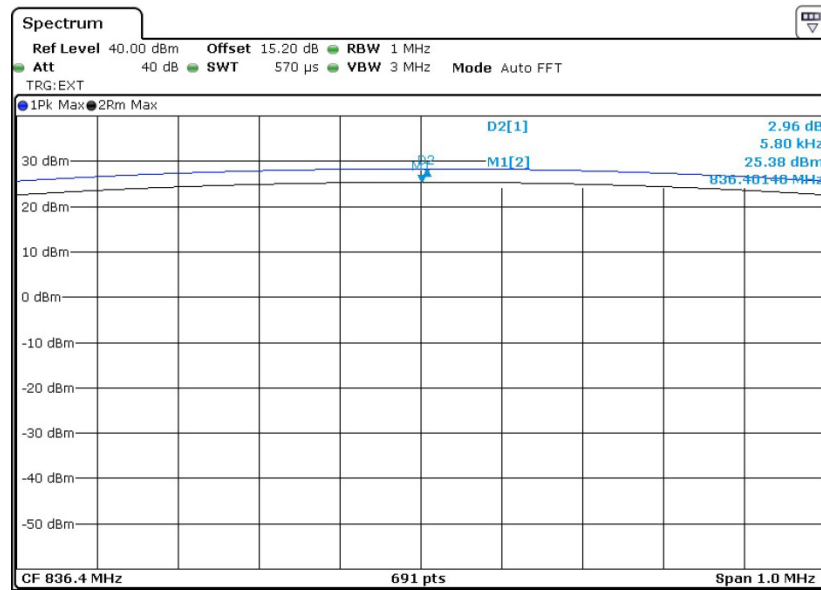



Peak-to-Average Ratio on Channel 251 (848.8 MHz)

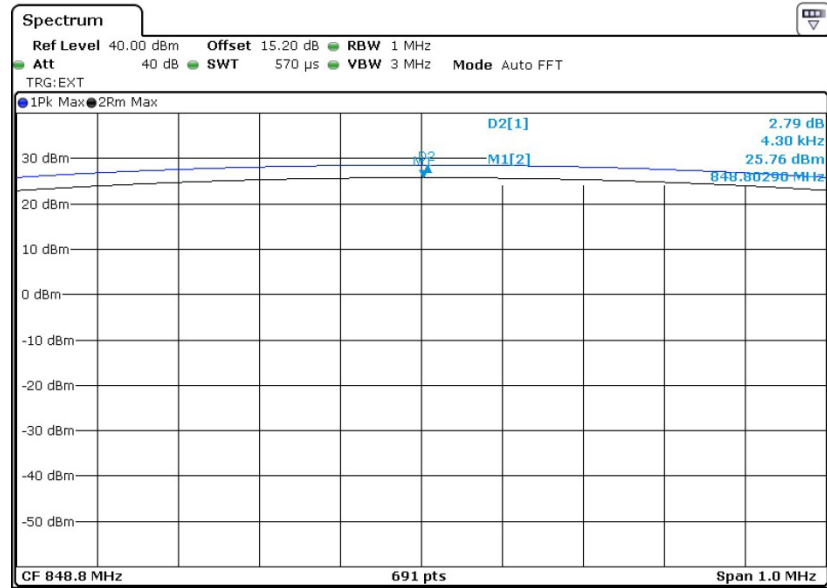



Band :	GSM 1900	Test Mode :	GSM Link (GMSK)
---------------	----------	--------------------	-----------------

Peak-to-Average Ratio on Channel 512 (1850.2 MHz)

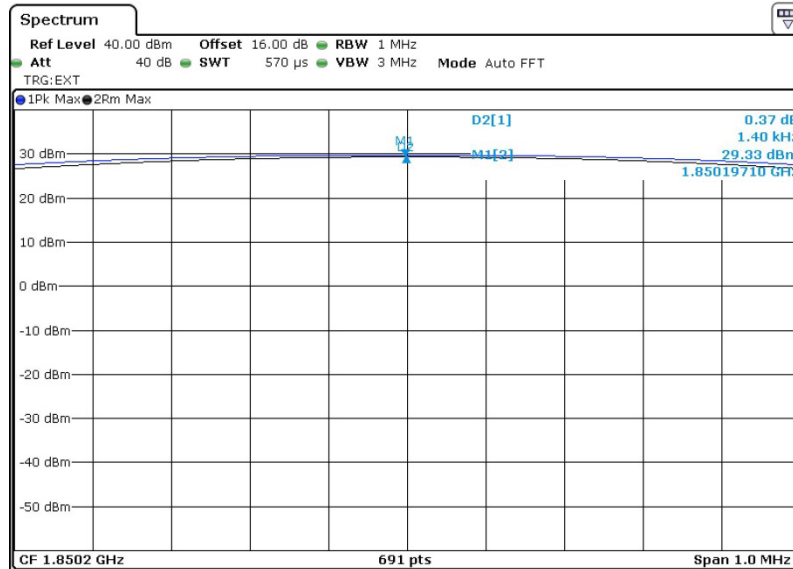

Peak-to-Average Ratio on Channel 661 (1880.0 MHz)

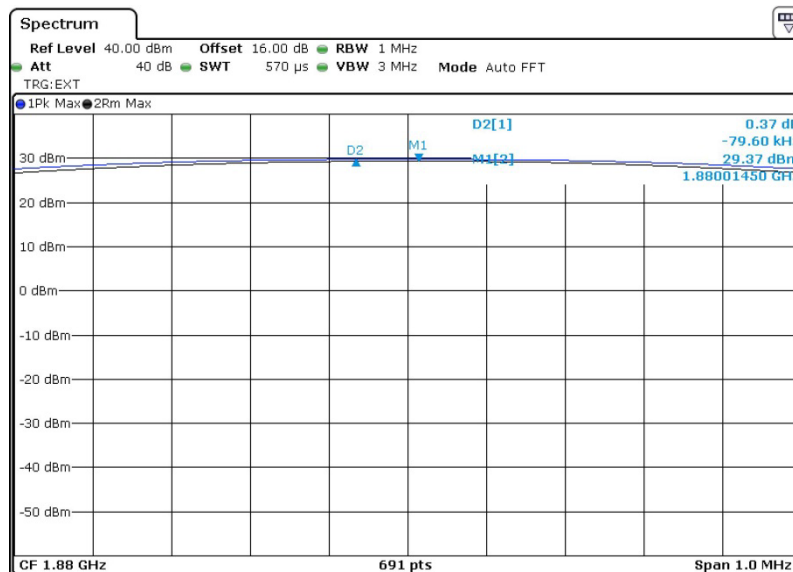



Peak-to-Average Ratio on Channel 810 (1909.8 MHz)

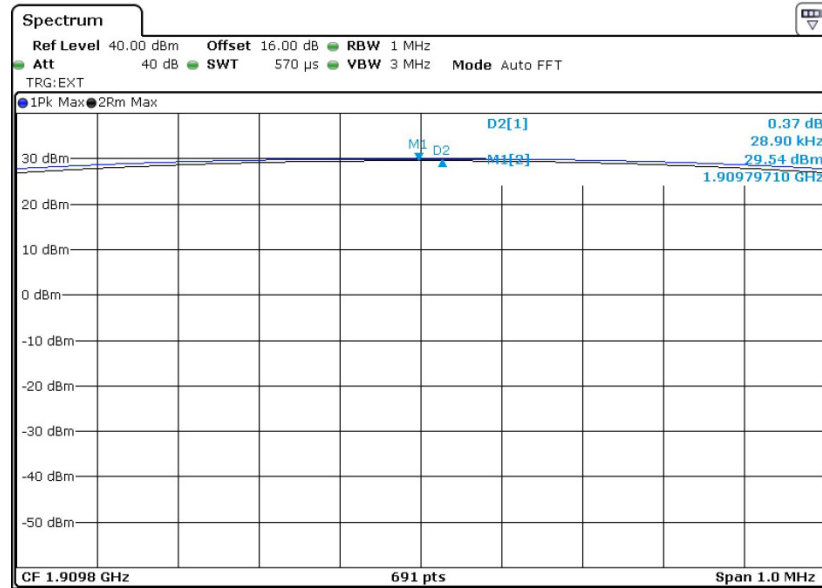



Band :	GSM 1900	Test Mode :	EDGE class 8 Link (8PSK)
---------------	----------	--------------------	--------------------------

Peak-to-Average Ratio on Channel 512 (1850.2 MHz)

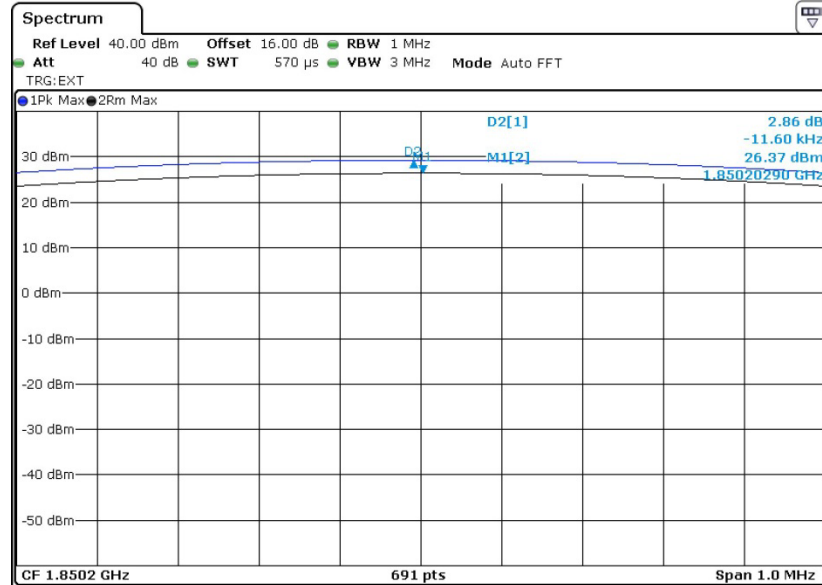

Peak-to-Average Ratio on Channel 661 (1880.0 MHz)

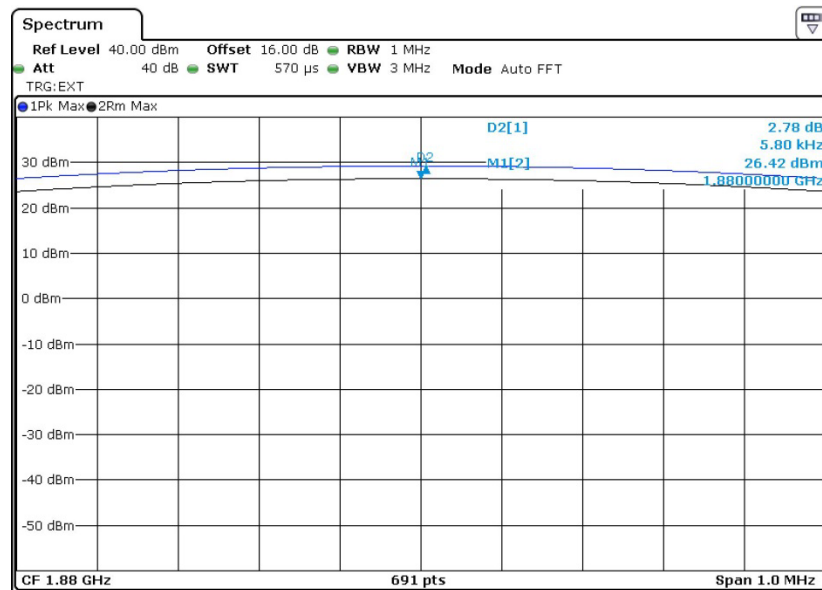



Peak-to-Average Ratio on Channel 810 (1909.8 MHz)

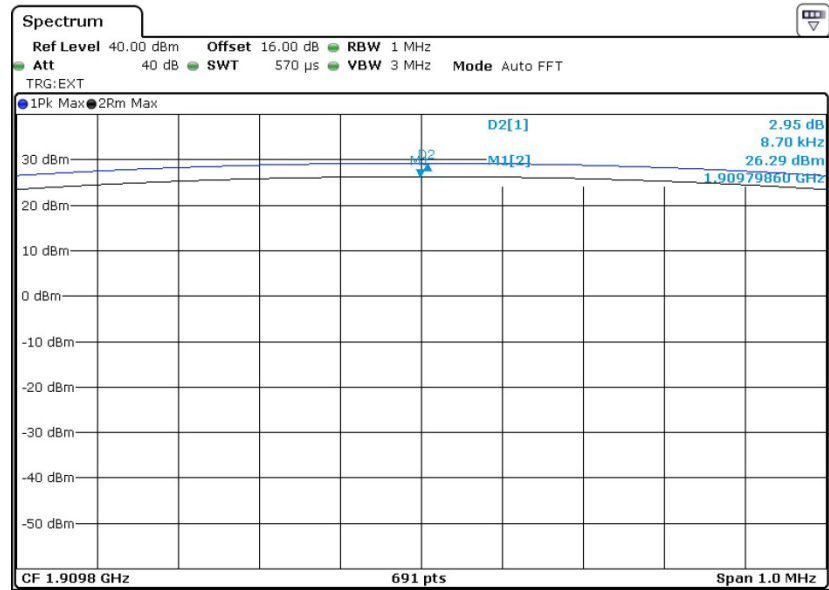



Band :	WCDMA Band V	Test Mode :	RMC 12.2Kbps Link (QPSK)
---------------	--------------	--------------------	--------------------------

Peak-to-Average Ratio on Channel 4132 (826.4 MHz)

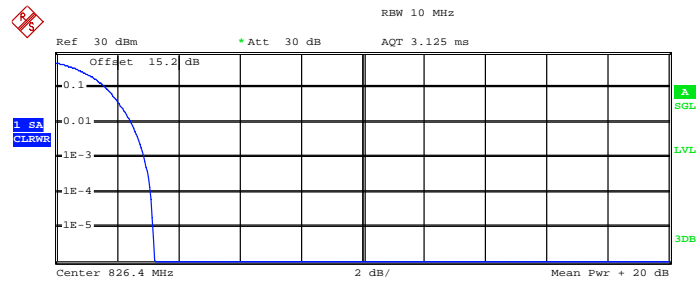

Complementary Cumulative Distribution Function (100000 samples)

Trace 1
 Mean 23.29 dBm
 Peak 26.52 dBm
 Crest 3.23 dB

10 %	1.64 dB
1 %	2.48 dB
.1 %	2.88 dB
.01 %	3.12 dB

Peak-to-Average Ratio on Channel 4182 (836.4 MHz)

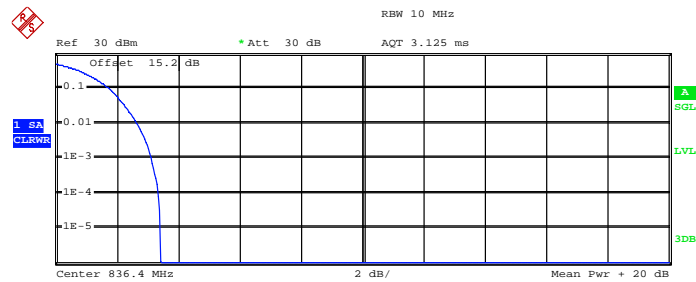

Complementary Cumulative Distribution Function (100000 samples)

Trace 1
 Mean 23.23 dBm
 Peak 26.66 dBm
 Crest 3.43 dB

10 %	1.76 dB
1 %	2.68 dB
.1 %	3.12 dB
.01 %	3.36 dB



Peak-to-Average Ratio on Channel 4233 (846.6 MHz)

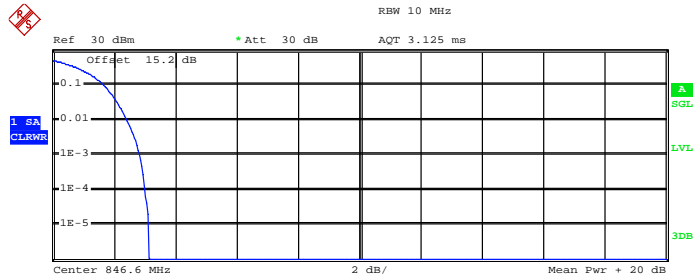

Complementary Cumulative Distribution Function (100000 samples)

Trace 1

Mean	23.51 dBm
Peak	26.66 dBm
Crest	3.15 dB
10 %	1.68 dB
1 %	2.44 dB
.1 %	2.84 dB
.01 %	3.00 dB



Band :	WCDMA Band IV	Test Mode :	RMC 12.2Kbps Link (QPSK)
---------------	---------------	--------------------	--------------------------

Peak-to-Average Ratio on Channel 1312 (1712.4 MHz)

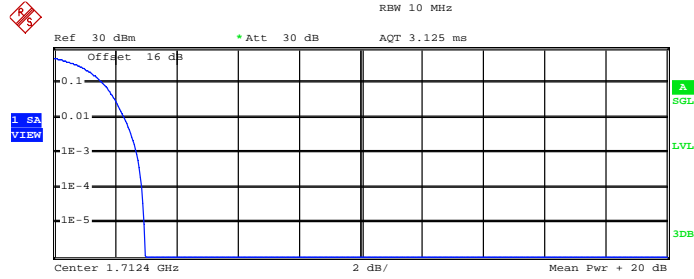

Complementary Cumulative Distribution Function (100000 samples)

Trace 1
 Mean 24.07 dBm
 Peak 27.03 dBm
 Crest 2.97 dB

10 %	1.60 dB
1 %	2.32 dB
.1 %	2.72 dB
.01 %	2.88 dB

Peak-to-Average Ratio on Channel 1413 (1732.6 MHz)

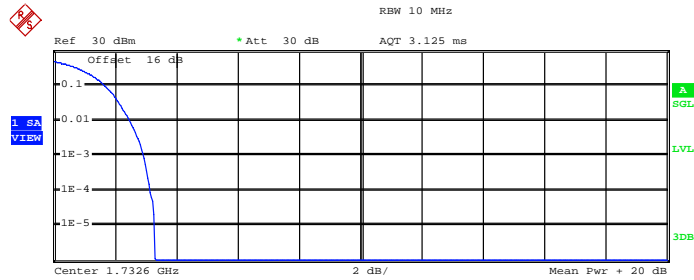

Complementary Cumulative Distribution Function (100000 samples)

Trace 1
 Mean 24.08 dBm
 Peak 27.39 dBm
 Crest 3.30 dB

10 %	1.68 dB
1 %	2.48 dB
.1 %	2.96 dB
.01 %	3.16 dB



Peak-to-Average Ratio on Channel 1513 (1752.6 MHz)

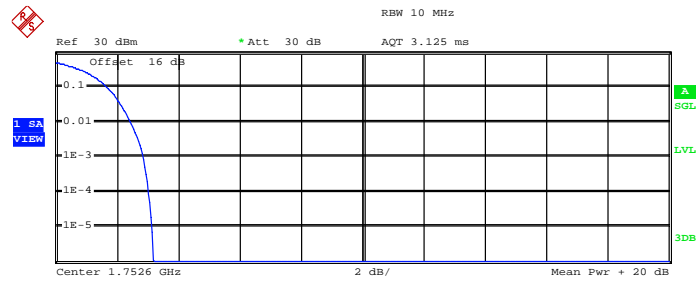

Complementary Cumulative Distribution Function (100000 samples)

Trace 1

Mean	24.28 dBm
Peak	27.46 dBm
Crest	3.18 dB
10 %	1.68 dB
1 %	2.44 dB
.1 %	2.88 dB
.01 %	3.04 dB



Band :	WCDMA Band II	Test Mode :	RMC 12.2Kbps Link (QPSK)
---------------	---------------	--------------------	--------------------------

Peak-to-Average Ratio on Channel 9262 (1852.4 MHz)

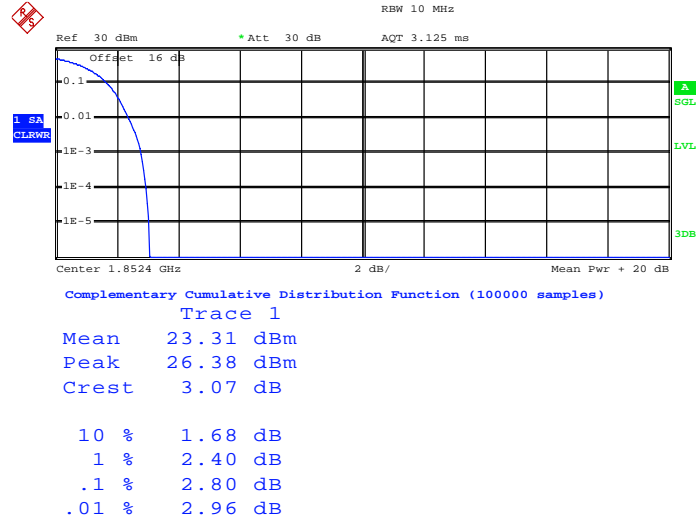

Peak-to-Average Ratio on Channel 9400 (1880.0 MHz)

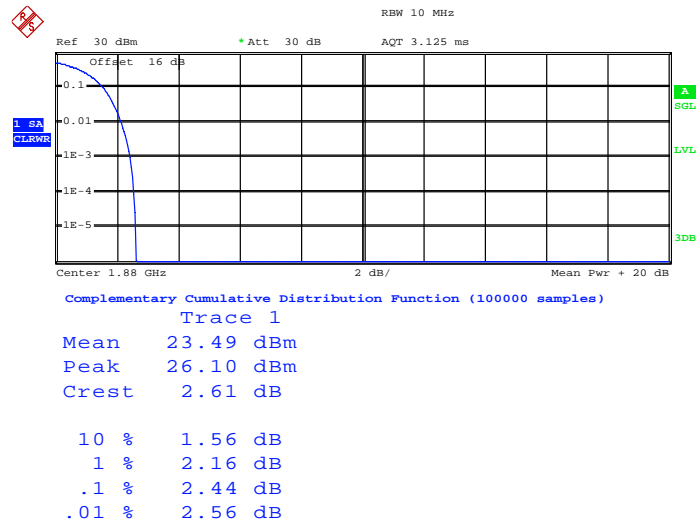



Peak-to-Average Ratio on Channel 9538 (1907.6 MHz)

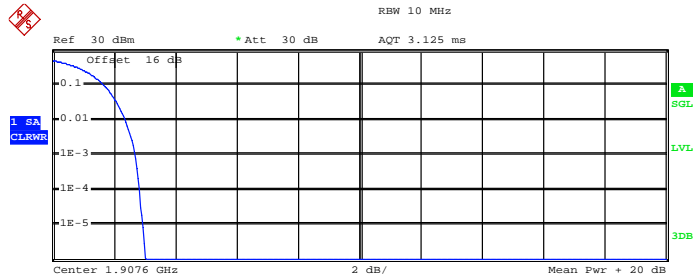

Complementary Cumulative Distribution Function (100000 samples)

Trace 1

Mean	23.51 dBm
Peak	26.52 dBm
Crest	3.01 dB
10 %	1.68 dB
1 %	2.36 dB
.1 %	2.68 dB
.01 %	2.84 dB



3.3 Effective Radiated Power and Effective Isotropic Radiated Power Measurement

3.3.1 Description of the ERP/EIRP Measurement

The substitution method, in ANSI / TIA / EIA-603-C-2004, was used for ERP/EIRP measurement, and the spectrum analyzer configuration follows KDB 971168 D01 Power Meas. License Digital Systems v02r02. The ERP of mobile transmitters must not exceed 7 Watts (Cellular Band) and the EIRP of mobile transmitters are limited to 2 Watts (PCS Band) and 1 Watts (AWS Band).

3.3.2 Measuring Instruments

The measuring equipment is listed in the section 4 of this test report.

3.3.3 Test Procedures

1. The testing follows FCC KDB 971168 v02r02 Section 5.2.1. (for CDMA/WCDMA), Section 5.2.2.2 (for GSM/GPRS/EDGE) and ANSI / TIA-603-C-2004 Section 2.2.17.
2. The EUT was placed on a non-conductive rotating platform 0.8 meters high in a semi-anechoic chamber. The radiated emission at the fundamental frequency was measured at 3 m with a test antenna and a spectrum analyzer with RMS detector per section 5. of KDB 971168 D01.
3. During the measurement, the system simulator parameters were set to force the EUT transmitting at maximum output power. The maximum emission was recorded from analyzer power level (LVL) from the 360 degrees rotation of the turntable and the test antenna raised and lowered over a range from 1 to 4 meters in both horizontally and vertically polarized orientations.
4. Effective Isotropic Radiated Power (EIRP) was measured by substitution method according to TIA/EIA-603-C. The EUT was replaced by the substitution antenna at same location, and then a known power from S.G. was applied into the dipole antenna through a Tx cable, and then recorded the maximum Analyzer reading through raised and lowered the test antenna. The correction factor (in dB) = S.G. - Tx Cable loss + Substitution antenna gain - Analyzer reading. Then the EUT's EIRP was calculated with the correction factor, $EIRP = LVL + \text{Correction factor}$ and $ERP = EIRP - 2.15$. Take the record of the output power at substitution antenna.



	GSM/GPRS/EDGE	WCDMA/HSPA
SPAN	500kHz	10MHz
RBW	10kHz	100kHz
VBW	30kHz	300kHz
Detector	RMS	RMS
Trace	Average	Average
Average Type	Power	Power
Sweep Count	100	100

3.3.4 Test Result of ERP

GSM850 (GSM) Radiated Power ERP					
Channel	Frequency (MHz)	Horizontal		Vertical	
		ERP(dBm)	ERP(W)	ERP(dBm)	ERP(W)
Lowest	824.2	32.47	1.7660	19.64	0.0920
Middle	836.4	31.95	1.5668	19.48	0.0887
Highest	848.8	30.38	1.0914	18.00	0.0631
Limit	ERP < 7W	Result		PASS	

GSM850 (EDGE class 8) Radiated Power ERP					
Channel	Frequency (MHz)	Horizontal		Vertical	
		ERP(dBm)	ERP(W)	ERP(dBm)	ERP(W)
Lowest	824.2	25.80	0.3802	12.96	0.0198
Middle	836.4	25.21	0.3319	12.66	0.0185
Highest	848.8	23.35	0.2163	10.87	0.0122
Limit	ERP < 7W	Result		PASS	

WCDMA Band V (RMC 12.2Kbps) Radiated Power ERP					
Channel	Frequency (MHz)	Horizontal		Vertical	
		ERP(dBm)	ERP(W)	ERP(dBm)	ERP(W)
Lowest	826.4	21.60	0.1445	8.88	0.0077
Middle	836.4	21.44	0.1393	8.80	0.0076
Highest	846.6	22.18	0.1652	9.70	0.0093
Limit	ERP < 7W	Result		PASS	



3.3.5 Test Result of EIRP

GSM1900 (GSM) Radiated Power EIRP					
Channel	Frequency (MHz)	Horizontal		Vertical	
		EIRP(dBm)	EIRP(W)	EIRP(dBm)	EIRP(W)
Lowest	1850.2	32.17	1.6482	31.95	1.5668
Middle	1880.0	32.84	1.9231	32.29	1.6943
Highest	1909.8	32.27	1.6866	32.15	1.6406
Limit	EIRP < 2W	Result		PASS	

GSM1900 (EDGE class 8) Radiated Power EIRP					
Channel	Frequency (MHz)	Horizontal		Vertical	
		EIRP(dBm)	EIRP(W)	EIRP(dBm)	EIRP(W)
Lowest	1850.2	27.88	0.6138	27.46	0.5572
Middle	1880.0	28.38	0.6887	27.94	0.6223
Highest	1909.8	28.09	0.6442	27.96	0.6252
Limit	EIRP < 2W	Result		PASS	

WCDMA Band II (RMC 12.2Kbps) Radiated Power EIRP					
Channel	Frequency (MHz)	Horizontal		Vertical	
		EIRP(dBm)	EIRP(W)	EIRP(dBm)	EIRP(W)
Lowest	1852.4	26.62	0.4592	26.29	0.4256
Middle	1880.0	26.89	0.4887	26.30	0.4266
Highest	1907.6	24.74	0.2979	24.60	0.2884
Limit	EIRP < 2W	Result		PASS	

WCDMA Band IV(RMC 12.2Kbps) Radiated Power EIRP					
Channel	Frequency (MHz)	Horizontal		Vertical	
		EIRP(dBm)	EIRP(W)	EIRP(dBm)	EIRP(W)
Lowest	1712.4	27.83	0.6067	27.67	0.5848
Middle	1732.6	26.53	0.4498	26.32	0.4285
Highest	1752.6	27.39	0.5483	27.60	0.5754
Limit	EIRP < 1W	Result		PASS	

3.4 99% Occupied Bandwidth and 26dB Bandwidth Measurement

3.4.1 Description of 99% Occupied Bandwidth and 26dB Bandwidth Measurement

The 99% occupied bandwidth is the width of a frequency band such that, below the lower and above the upper frequency limits, the mean powers emitted are each equal to a specified percentage 0.5% of the total mean transmitted power.

The emission bandwidth is defined as the width of the signal between two points, located at the 2 sides of the carrier frequency, outside of which all emissions are attenuated at least 26 dB below the transmitter power.

3.4.2 Measuring Instruments

The measuring equipment is listed in the section 4 of this test report.

3.4.3 Test Procedures

5. The testing follows FCC KDB 971168 v02r02 Section 4.2.
6. The EUT was connected to the spectrum analyzer and system simulator via a power divider.
7. The RF output of the EUT was connected to the spectrum analyzer by RF cable and attenuator. The path loss was compensated to the results for each measurement.
8. The 99% occupied bandwidth were measured, set RBW= 1% of span, VBW= 3*RBW, peak detector, trace maximum hold.
9. The 26dB bandwidth were measured, set RBW= 1% of EBW, VBW= 3*RBW, peak detector, trace maximum hold.

3.4.4 Test Setup

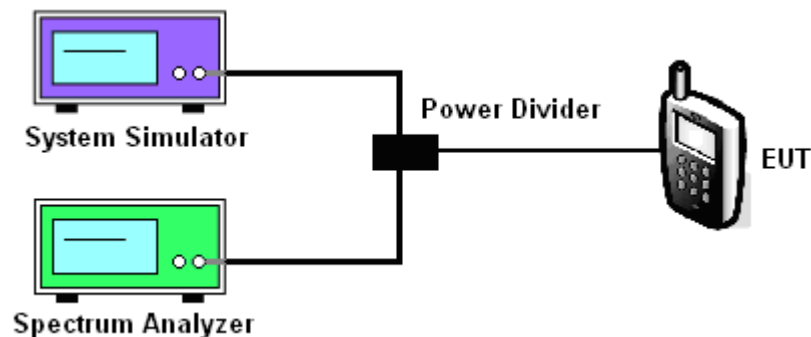



3.4.5 Test Result of Occupied Bandwidth and 26dB Bandwidth

Cellular Band						
Modes	GSM850 (GSM)			GSM850 (EDGE class 8)		
Channel	128 (Low)	189 (Mid)	251 (High)	128 (Low)	189 (Mid)	251 (High)
Frequency (MHz)	824.2	836.4	848.8	824.2	836.4	848.8
99% OBW (kHz)	246.00	244.00	244.00	244.00	244.00	242.00
26dB BW (kHz)	312.00	316.00	312.00	304.00	306.00	312.00

PCS Band						
Modes	GSM1900 (GSM)			GSM1900 (EDGE class 8)		
Channel	512 (Low)	661 (Mid)	810 (High)	512 (Low)	661 (Mid)	810 (High)
Frequency (MHz)	1850.2	1880	1909.8	1850.2	1880	1909.8
99% OBW (kHz)	244.00	246.00	246.00	250.00	246.00	248.00
26dB BW (kHz)	314.00	310.00	310.00	312.00	308.00	314.00

Cellular Band			
Modes	WCDMA Band V (RMC 12.2Kbps)		
Channel	4132 (Low)	4182 (Mid)	4233 (High)
Frequency (MHz)	826.4	836.4	846.6
99% OBW (MHz)	4.16	4.16	4.18
26dB BW (MHz)	4.68	4.68	4.68

AWS Band			
Modes	WCDMA Band IV (RMC 12.2Kbps)		
Channel	1312(Low)	1413 (Mid)	1513 (High)
Frequency (MHz)	1712.4	1732.6	1752.6
99% OBW (MHz)	4.18	4.18	4.18
26dB BW (MHz)	4.72	4.68	4.68



PCS Band			
Modes	WCDMA Band II (RMC 12.2Kbps)		
Channel	9262 (Low)	9400 (Mid)	9538 (High)
Frequency (MHz)	1852.4	1880	1907.6
99% OBW (MHz)	4.18	4.18	4.18
26dB BW (MHz)	4.68	4.70	4.68



3.4.6 Test Result (Plots) of Occupied Bandwidth and 26dB Bandwidth

Band :	GSM 850	Test Mode :	GSM Link (GMSK)
--------	---------	-------------	-----------------

99% Occupied Bandwidth Plot on Channel 128 (824.2 MHz)

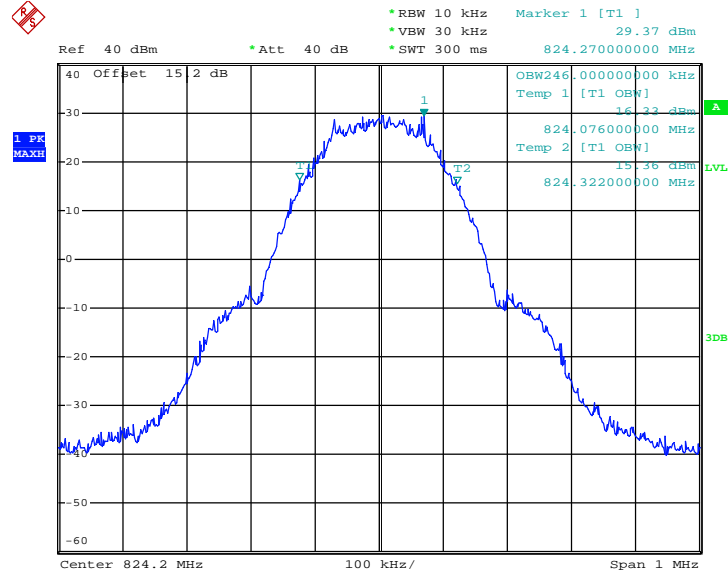

26dB Bandwidth Plot on Channel 128 (824.2 MHz)

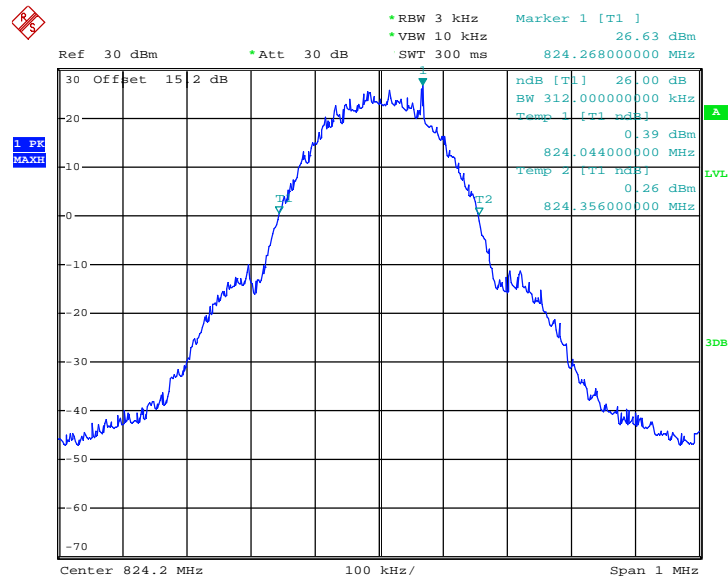



99% Occupied Bandwidth Plot on Channel 189 (836.4 MHz)

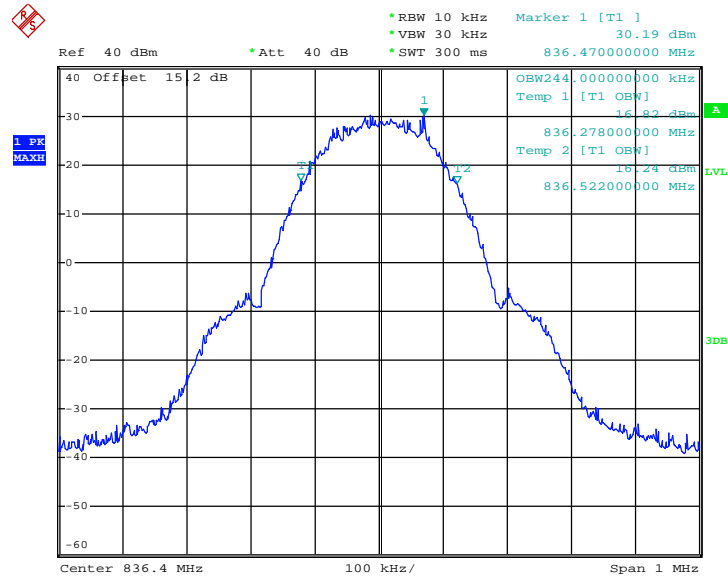

26dB Bandwidth Plot on Channel 189 (836.4 MHz)

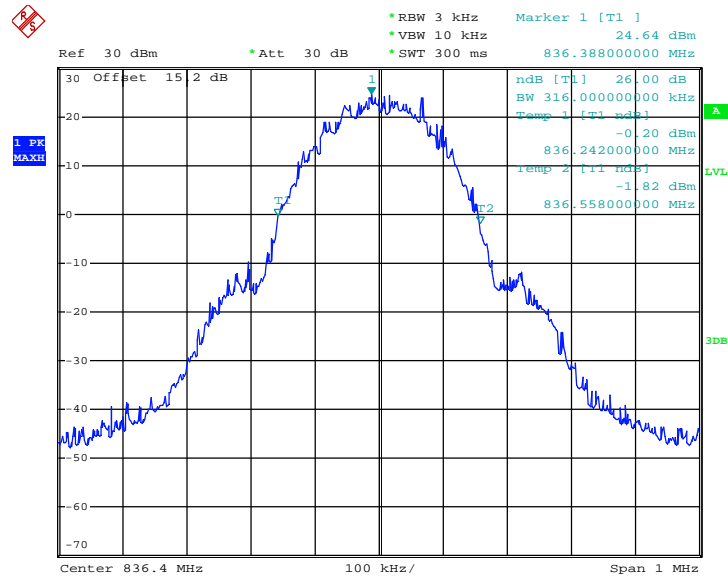



99% Occupied Bandwidth Plot on Channel 251 (848.8 MHz)

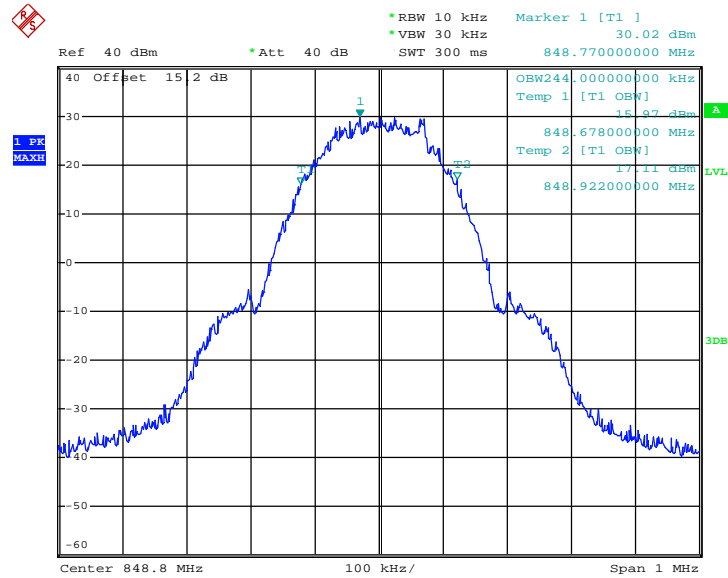

26dB Bandwidth Plot on Channel 251 (848.8 MHz)

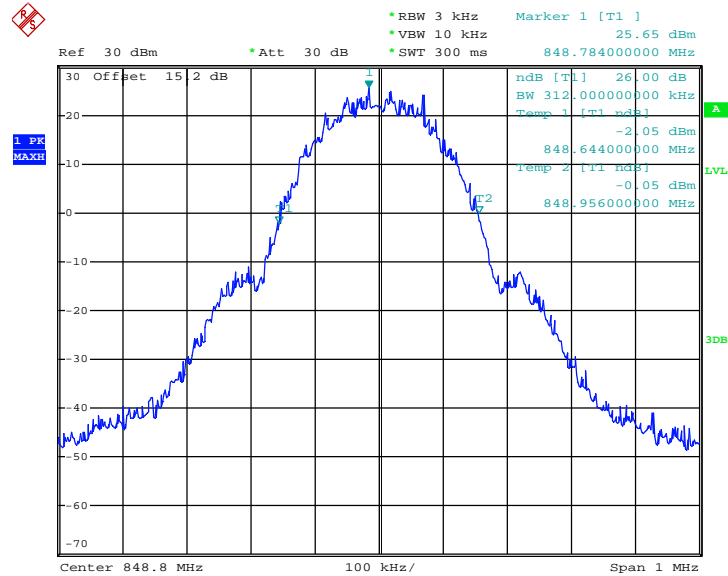



Band :	GSM 850	Test Mode :	EDGE class 8 Link (8PSK)
---------------	---------	--------------------	--------------------------

99% Occupied Bandwidth Plot on Channel 128 (824.2 MHz)

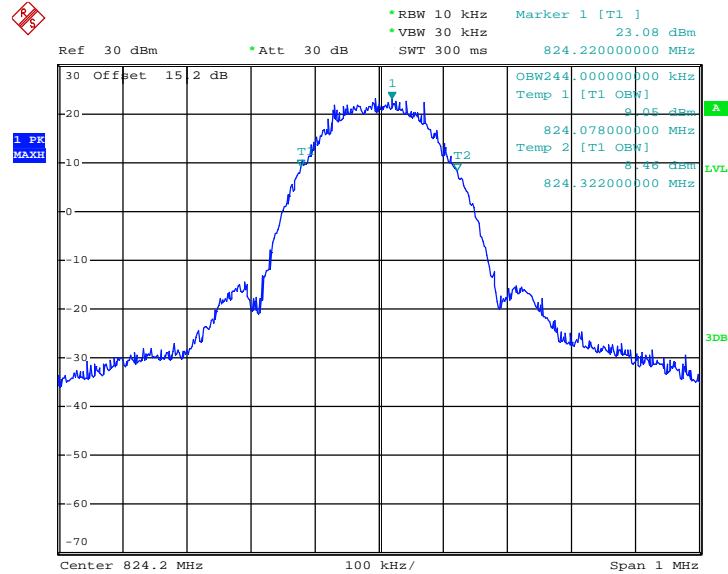

26dB Bandwidth Plot on Channel 128 (824.2 MHz)

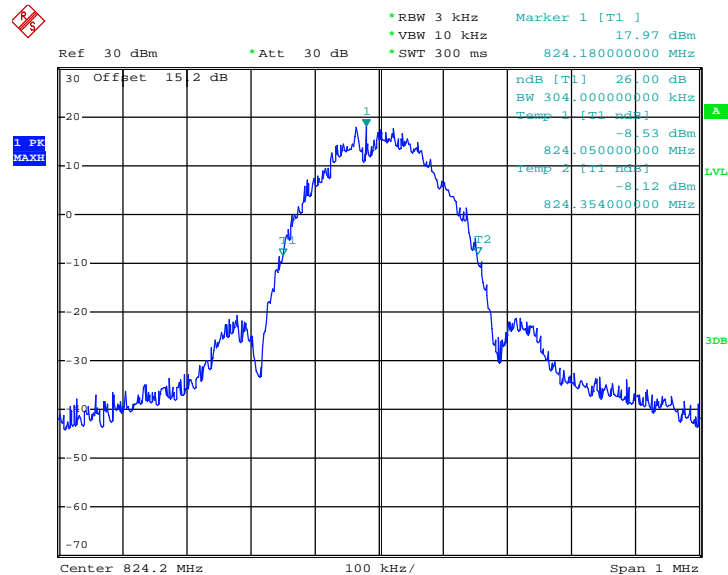



99% Occupied Bandwidth Plot on Channel 189 (836.4 MHz)

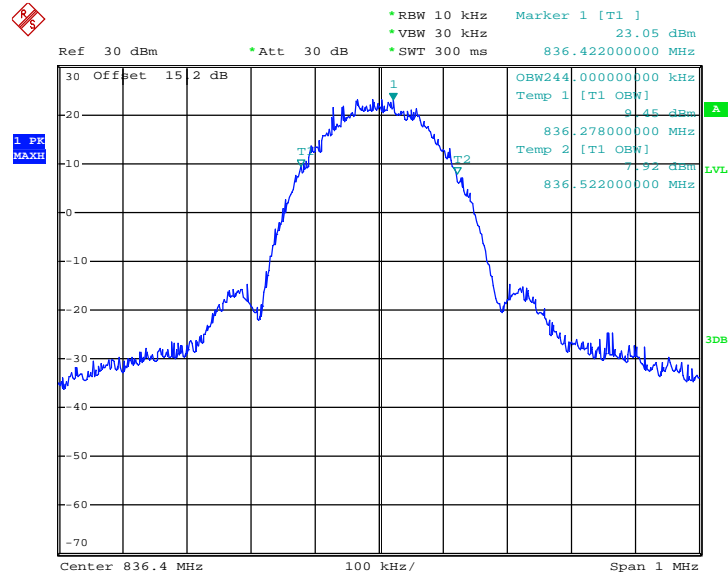

26dB Bandwidth Plot on Channel 189 (836.4 MHz)

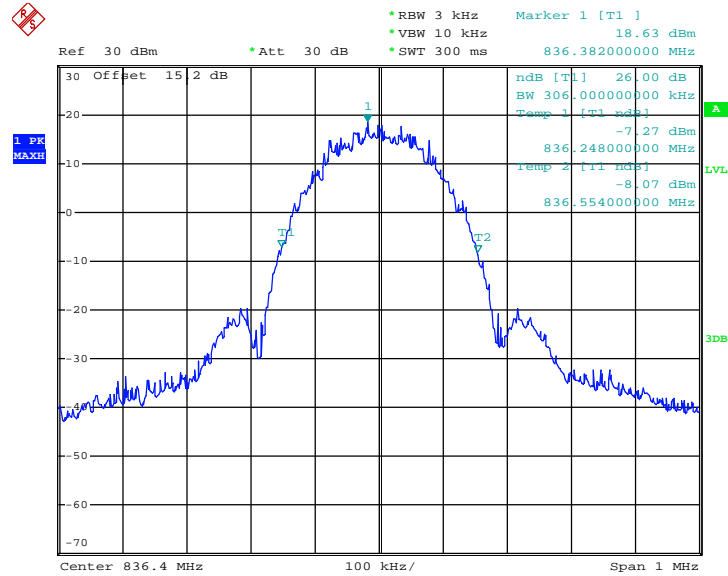



99% Occupied Bandwidth Plot on Channel 251 (848.8 MHz)

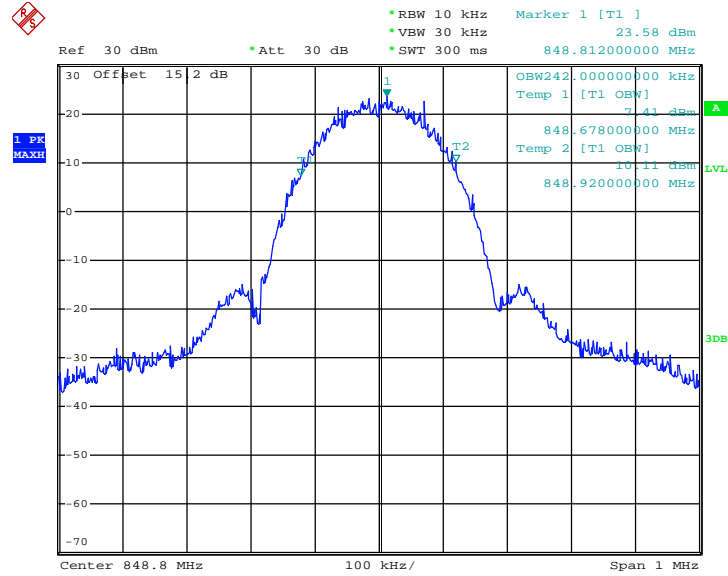

26dB Bandwidth Plot on Channel 251 (848.8 MHz)

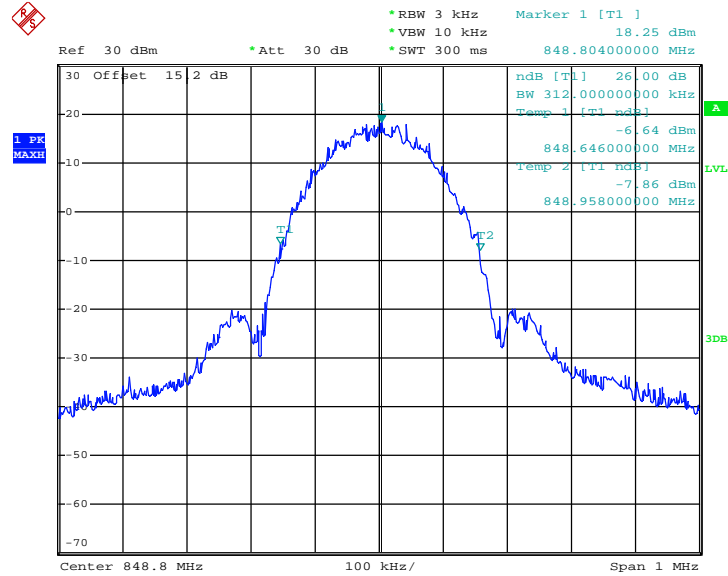



Band :	GSM 1900	Test Mode :	GSM Link (GMSK)
--------	----------	-------------	-----------------

99% Occupied Bandwidth Plot on Channel 512 (1850.2 MHz)

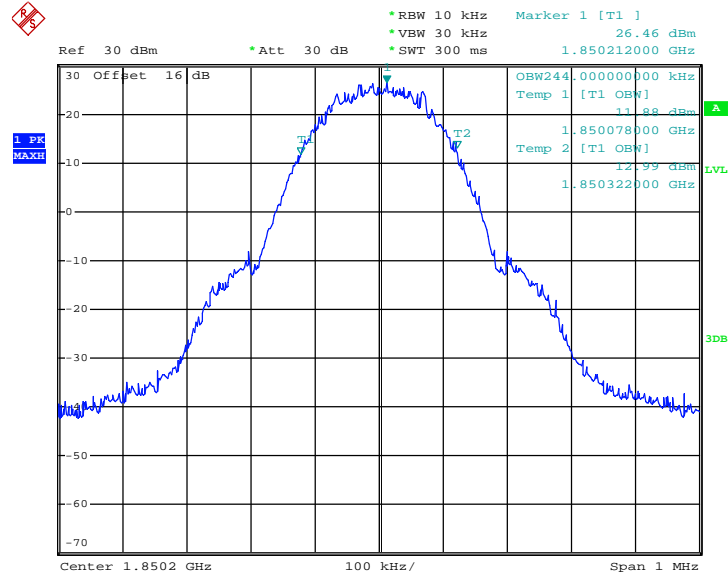

26dB Bandwidth Plot on Channel 512 (1850.2 MHz)

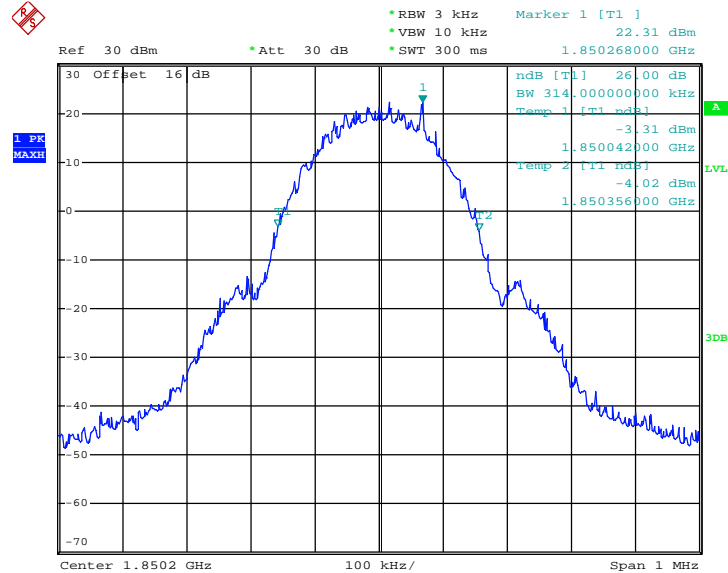



99% Occupied Bandwidth Plot on Channel 661 (1880.0 MHz)

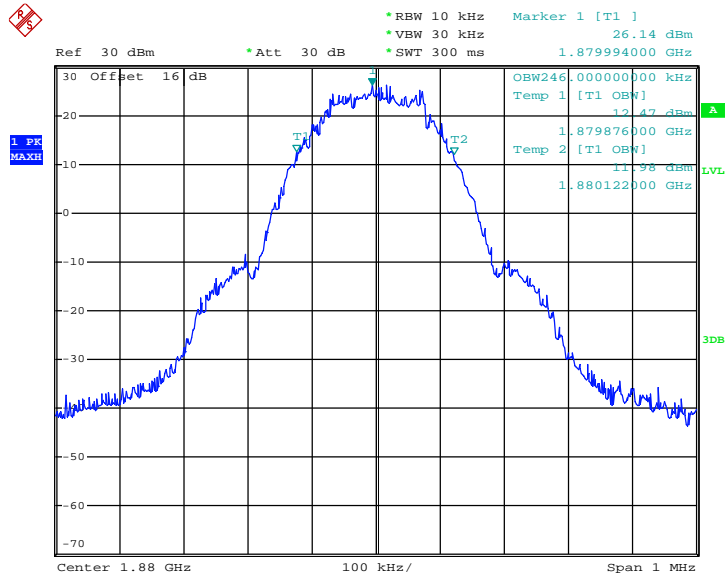

26dB Bandwidth Plot on Channel 661 (1880.0 MHz)

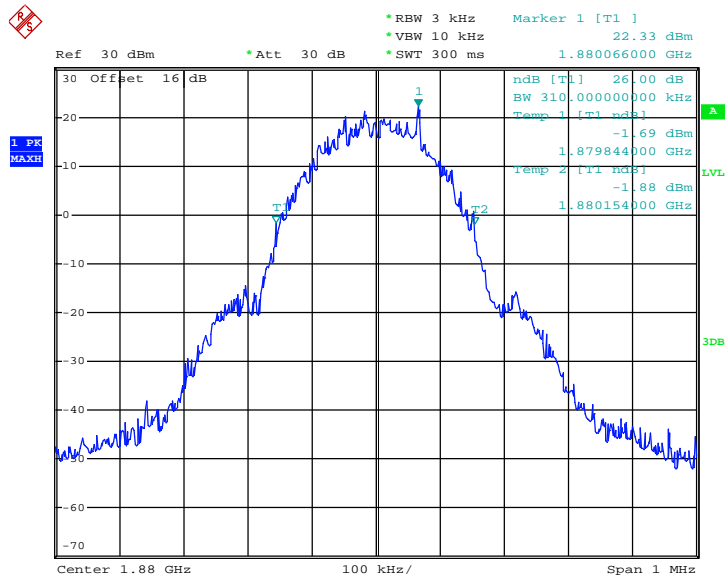



99% Occupied Bandwidth Plot on Channel 810 (1909.8 MHz)

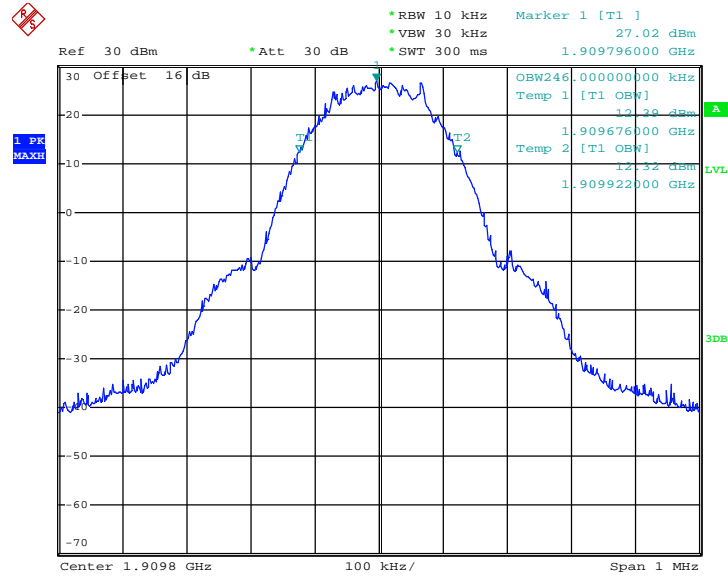

26dB Bandwidth Plot on Channel 810 (1909.8 MHz)

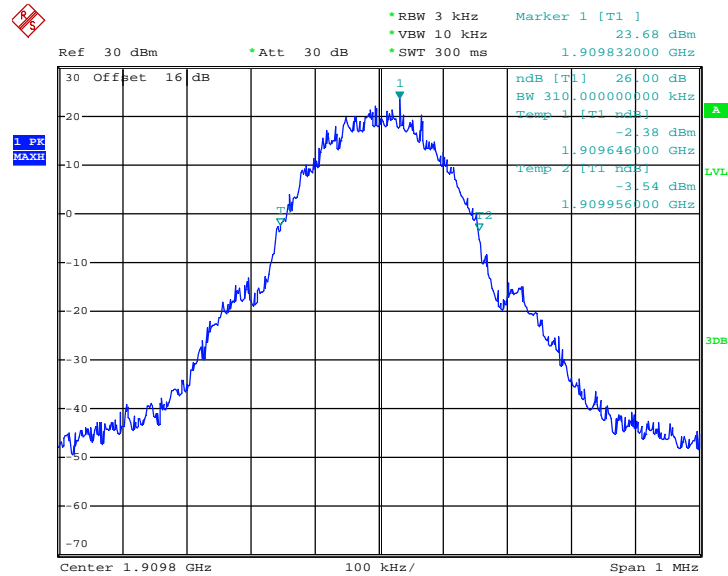



Band :	GSM 1900	Test Mode :	EDGE class 8 Link (8PSK)
--------	----------	-------------	--------------------------

99% Occupied Bandwidth Plot on Channel 512 (1850.2 MHz)

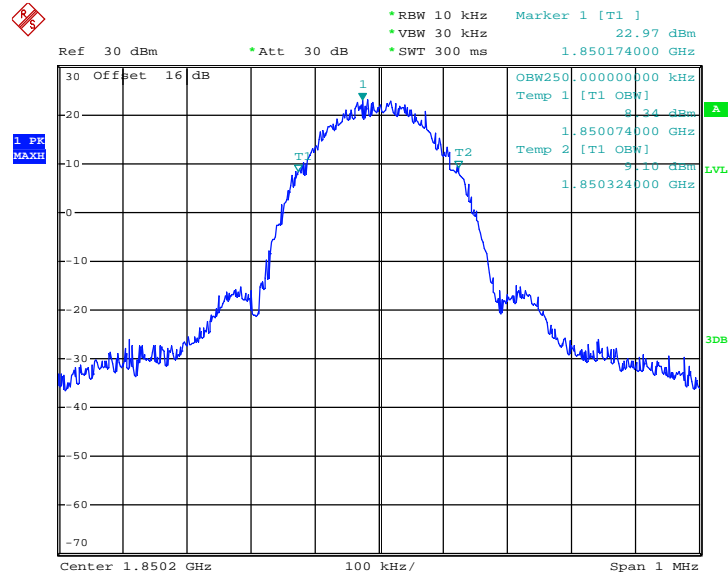

26dB Bandwidth Plot on Channel 512 (1850.2 MHz)

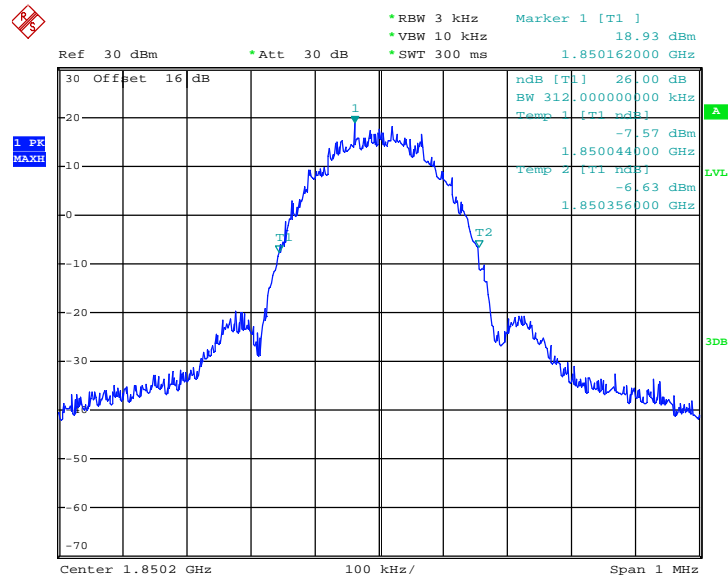



99% Occupied Bandwidth Plot on Channel 661 (1880.0 MHz)

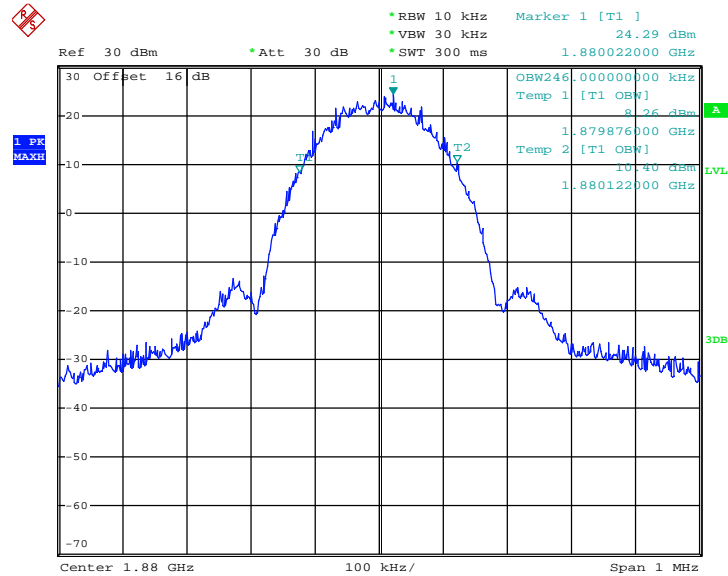

26dB Bandwidth Plot on Channel 661 (1880.0 MHz)

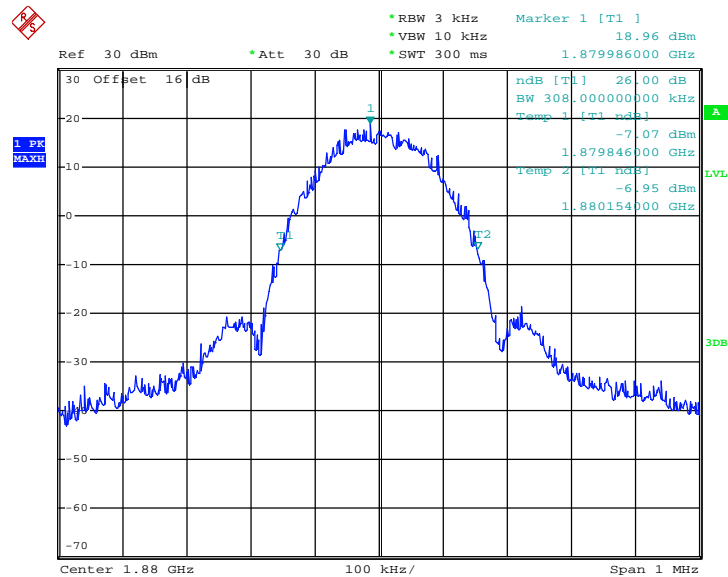



99% Occupied Bandwidth Plot on Channel 810 (1909.8 MHz)

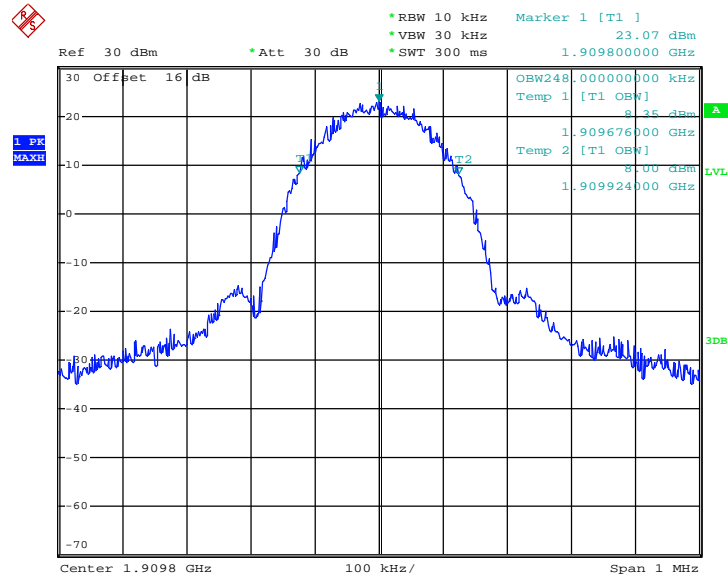

26dB Bandwidth Plot on Channel 810 (1909.8 MHz)

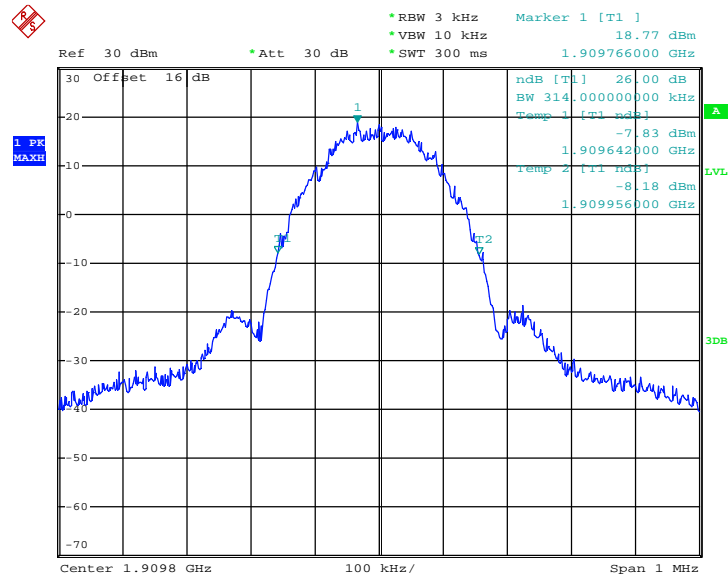



Band :	WCDMA Band V	Test Mode :	RMC 12.2Kbps Link (QPSK)
--------	--------------	-------------	--------------------------

99% Occupied Bandwidth Plot on Channel 4132 (826.4 MHz)

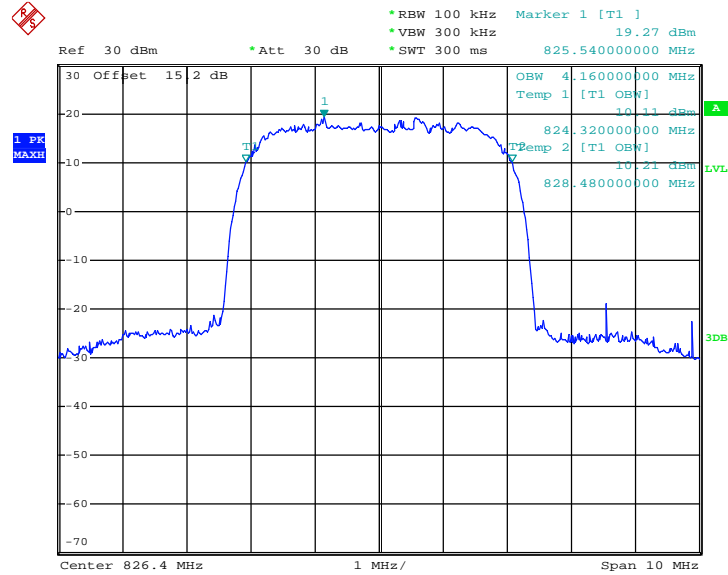

26dB Bandwidth Plot on Channel 4132 (826.4 MHz)

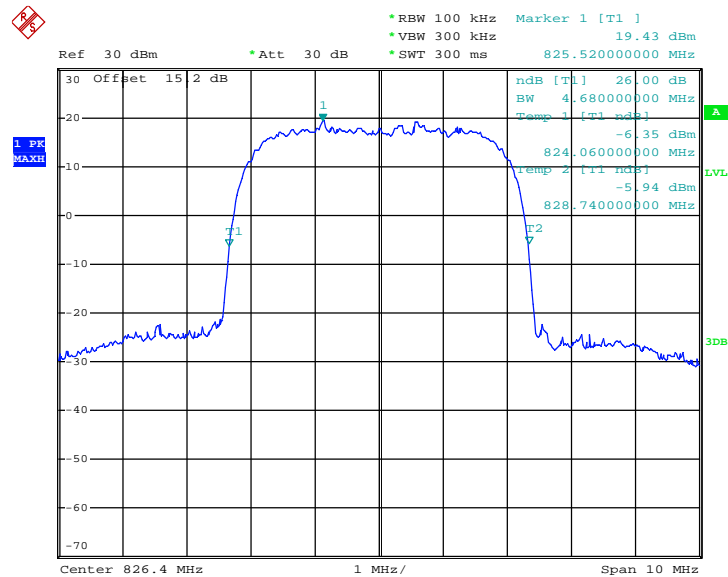



99% Occupied Bandwidth Plot on Channel 4182 (836.4 MHz)

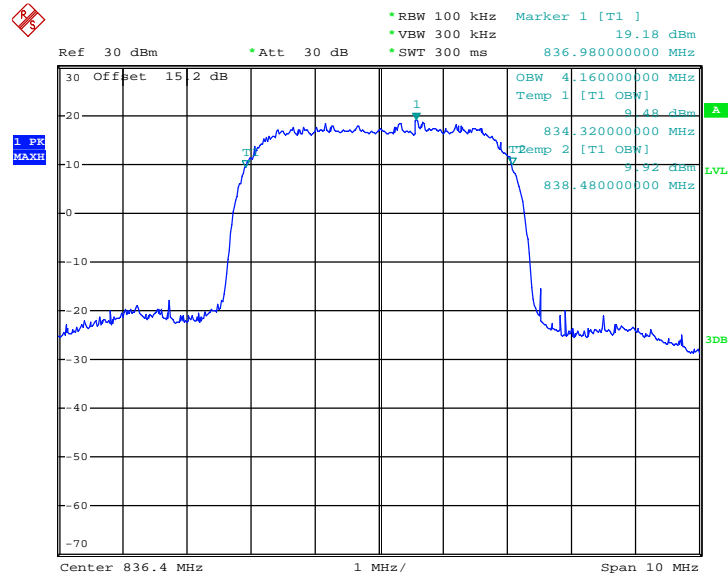

26dB Bandwidth Plot on Channel 4182 (836.4 MHz)

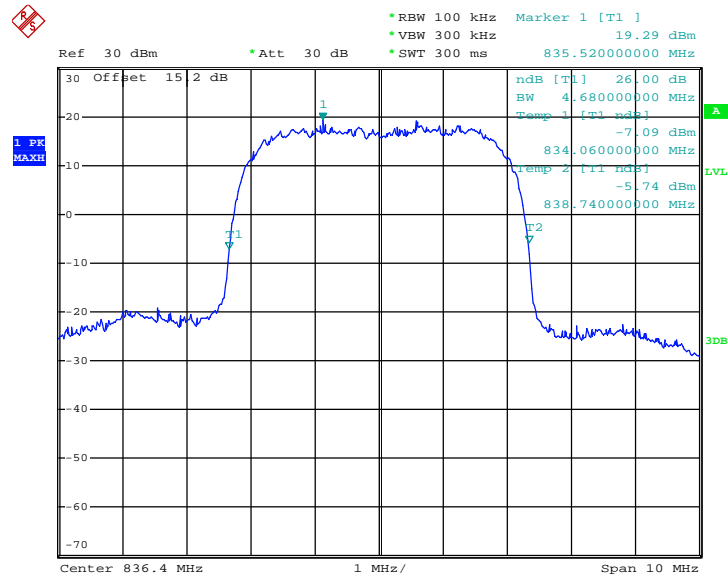



99% Occupied Bandwidth Plot on Channel 4233 (846.6 MHz)

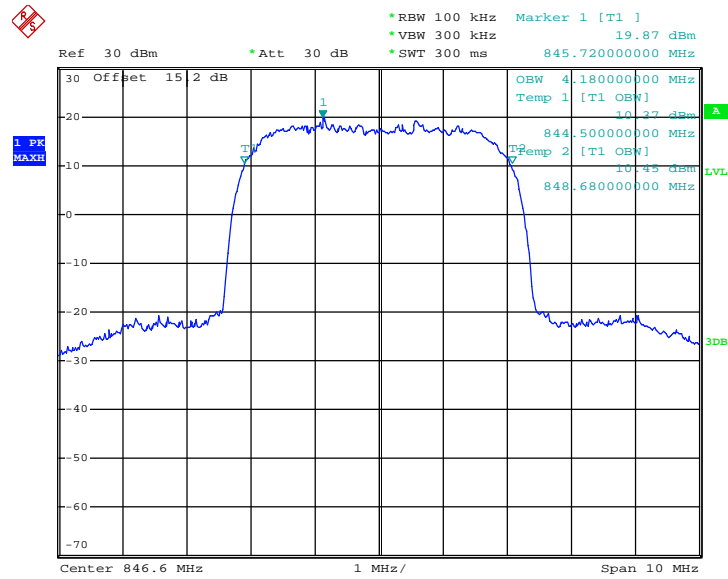

26dB Bandwidth Plot on Channel 4233 (846.6 MHz)

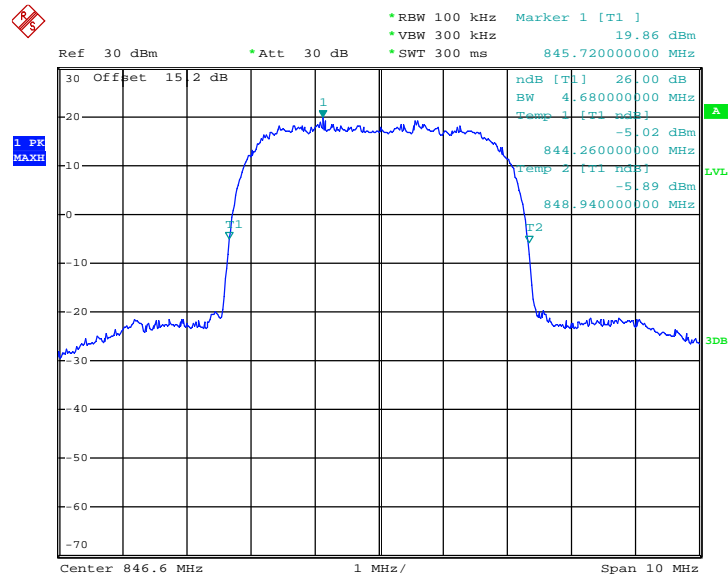



Band :	WCDMA Band IV	Test Mode :	RMC 12.2Kbps Link (QPSK)
---------------	---------------	--------------------	--------------------------

99% Occupied Bandwidth Plot on Channel 1312 (1712.4 MHz)

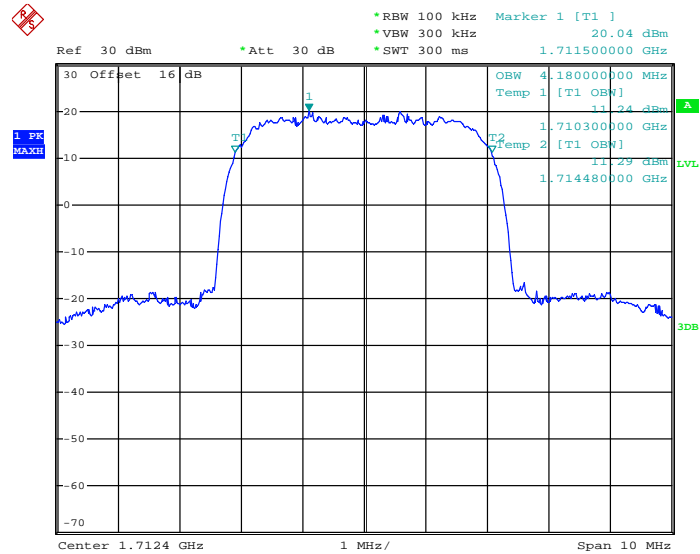

26dB Bandwidth Plot on Channel 1312 (1712.4 MHz)

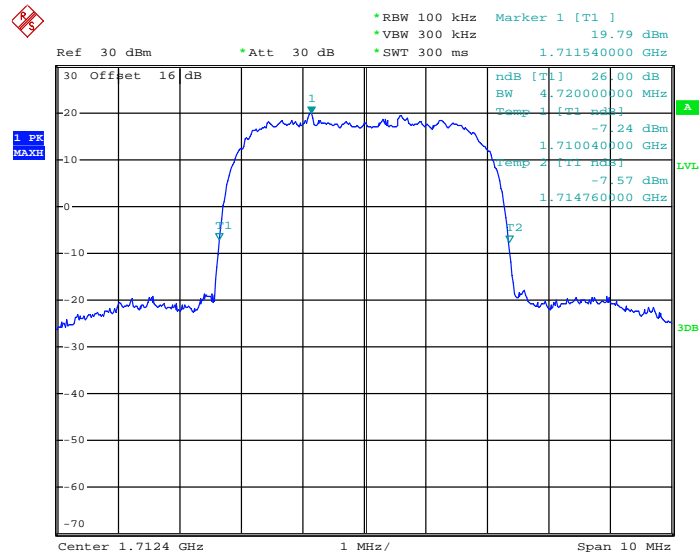



99% Occupied Bandwidth Plot on Channel 1413 (1732.6 MHz)

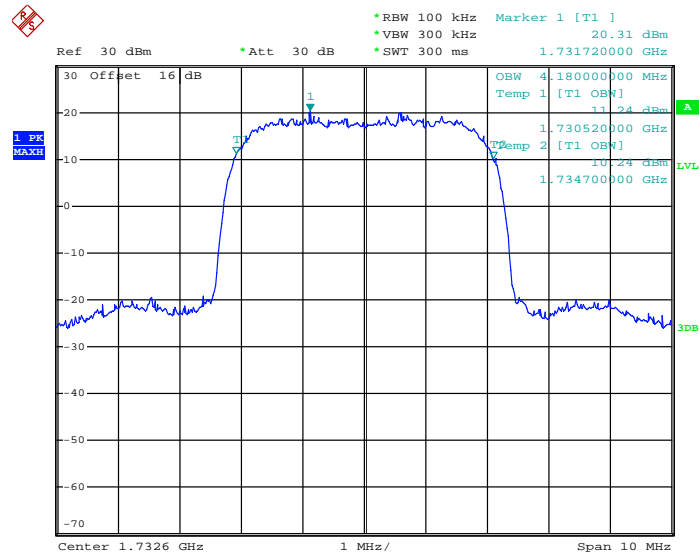

26dB Bandwidth Plot on Channel 1413 (1732.6 MHz)

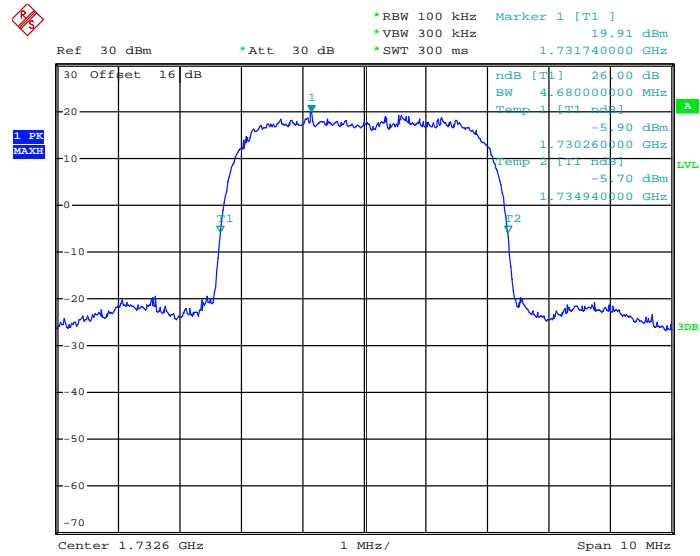



99% Occupied Bandwidth Plot on Channel 1513 (1752.6 MHz)

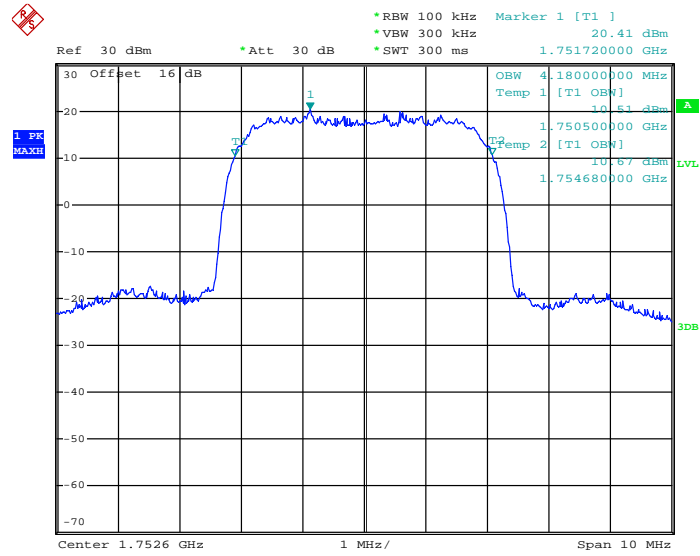

26dB Bandwidth Plot on Channel 1513 (1752.6 MHz)

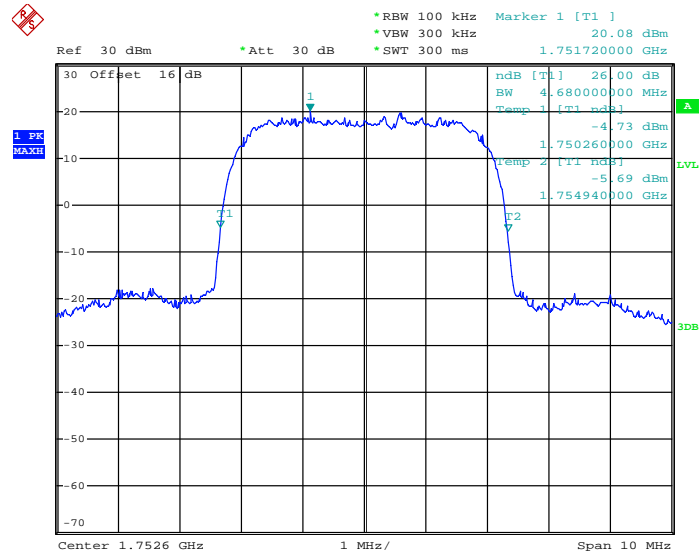



Band :	WCDMA Band II	Test Mode :	RMC 12.2Kbps Link (QPSK)
--------	---------------	-------------	--------------------------

99% Occupied Bandwidth Plot on Channel 9262 (1852.4 MHz)

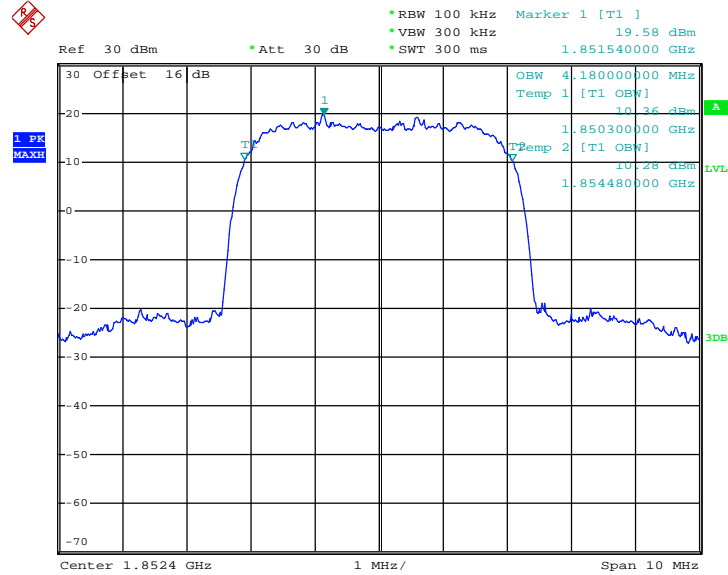

26dB Bandwidth Plot on Channel 9262 (1852.4 MHz)

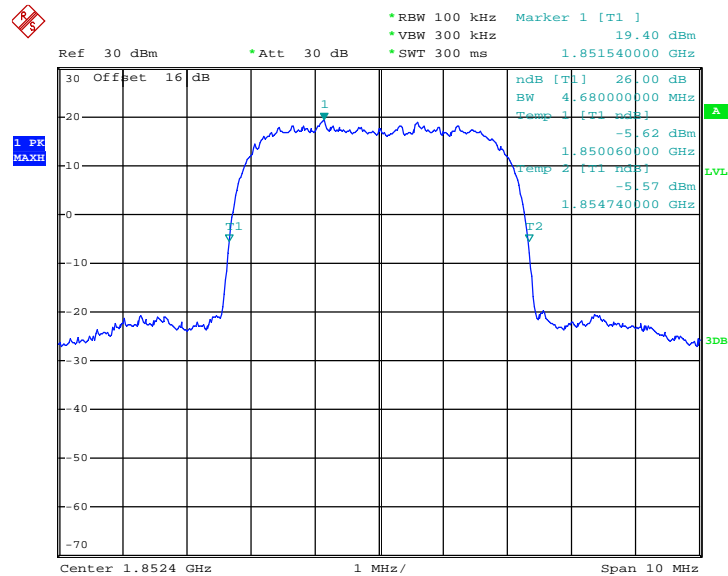



99% Occupied Bandwidth Plot on Channel 9400 (1880.0 MHz)

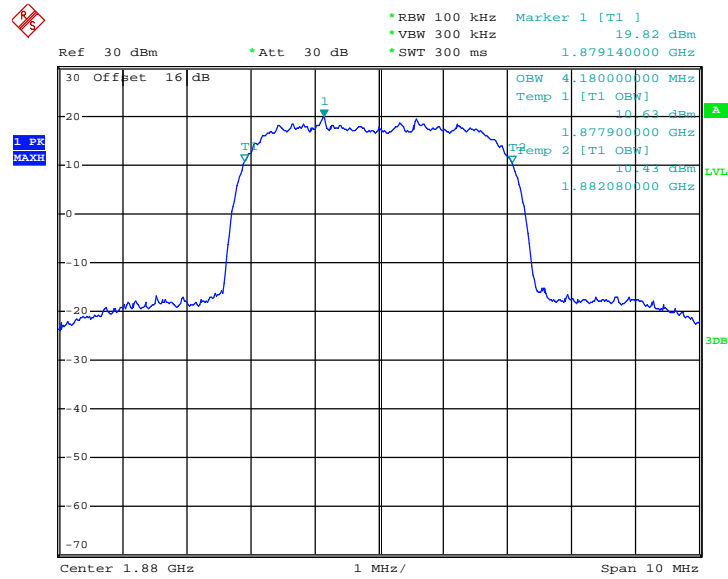

26dB Bandwidth Plot on Channel 9400 (1880.0 MHz)

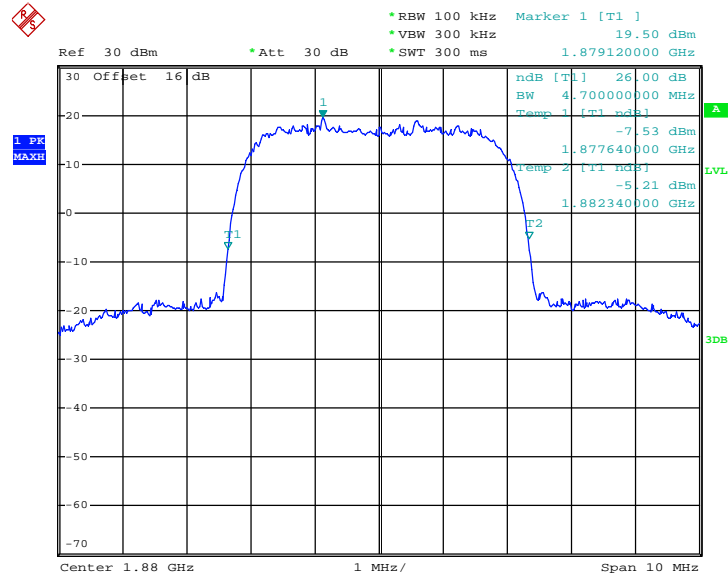



99% Occupied Bandwidth Plot on Channel 9538 (1907.6 MHz)

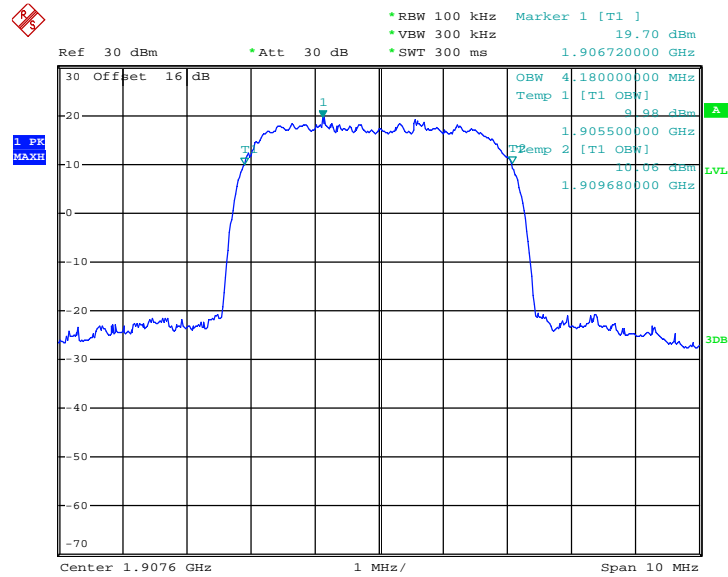

26dB Bandwidth Plot on Channel 9538 (1907.6 MHz)

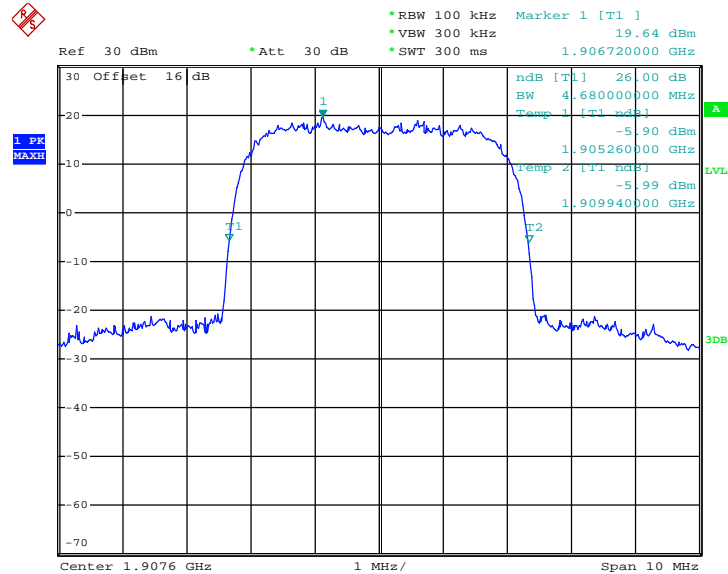

3.5 Band Edge Measurement

3.5.1 Description of Band Edge Measurement

The power of any emission outside of the authorized operating frequency ranges must be lower than the transmitter power (P) by a factor of at least $43 + 10 \log (P)$ dB.

3.5.2 Measuring Instruments

The measuring equipment is listed in the section 4 of this test report.

3.5.3 Test Procedures

1. The testing follows FCC KDB 971168 v02r02 Section 6.0.
2. The EUT was connected to the spectrum analyzer and system simulator via a power divider.
3. The RF output of EUT was connected to the spectrum analyzer by an RF cable and attenuator. The path loss was compensated to the results for each measurement.
4. The band edges of low and high channels for the highest RF powers were measured.
5. The RF fundamental frequency should be excluded against the limit line in the operating frequency band.
6. The limit line is derived from $43 + 10\log(P)$ dB below the transmitter power P(Watts)

$$= P(W) - [43 + 10\log(P)] \text{ (dB)}$$

$$= [30 + 10\log(P)] \text{ (dBm)} - [43 + 10\log(P)] \text{ (dB)}$$

$$= -13\text{dBm}.$$

3.5.4 Test Setup

<Conducted Band Edge >

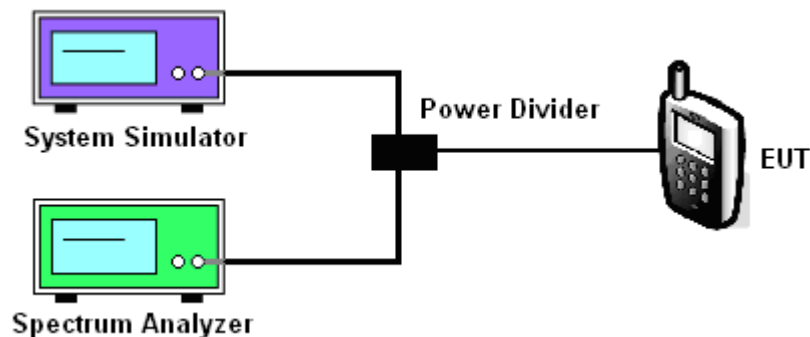



3.5.5 Test Result (Plots) of Conducted Band Edge

Band :	GSM850	Test Mode :	GSM Link (GMSK)
--------	--------	-------------	-----------------

Lower Band Edge Plot on Channel 128 (824.2 MHz)

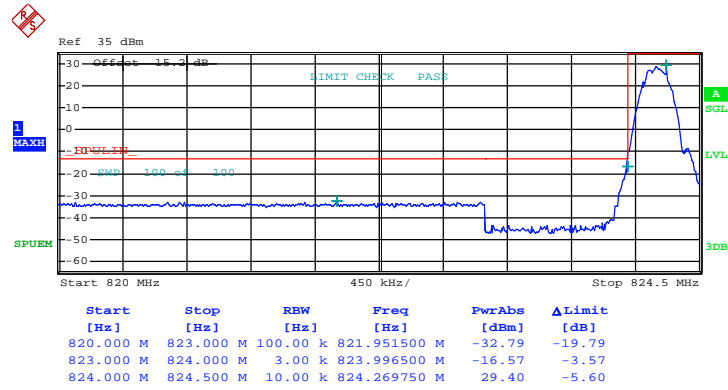



Band :	GSM850	Test Mode :	GSM Link (GMSK)
--------	--------	-------------	-----------------

Higher Band Edge Plot on Channel 251 (848.8 MHz)

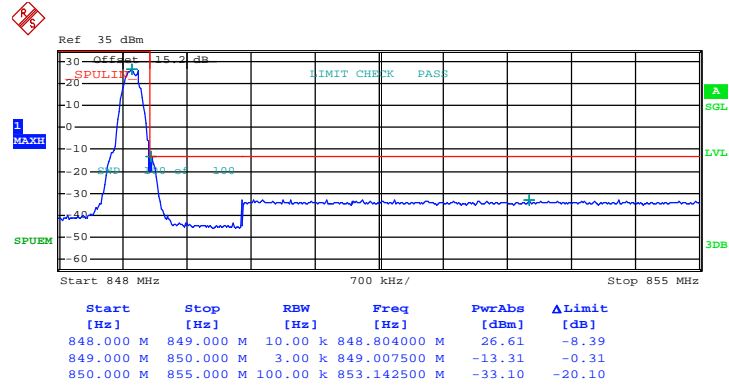



Band :	GSM850	Test Mode :	EDGE class 8 Link (8PSK)
--------	--------	-------------	--------------------------

Lower Band Edge Plot on Channel 128 (824.2 MHz)

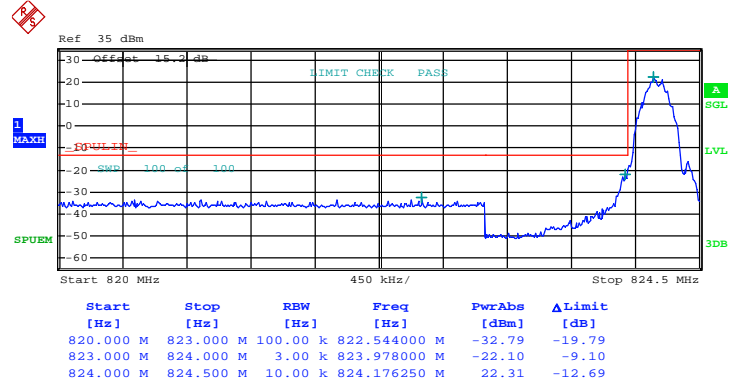



Band :	GSM850	Test Mode :	EDGE class 8 Link (8PSK)
--------	--------	-------------	--------------------------

Higher Band Edge Plot on Channel 251 (848.8 MHz)

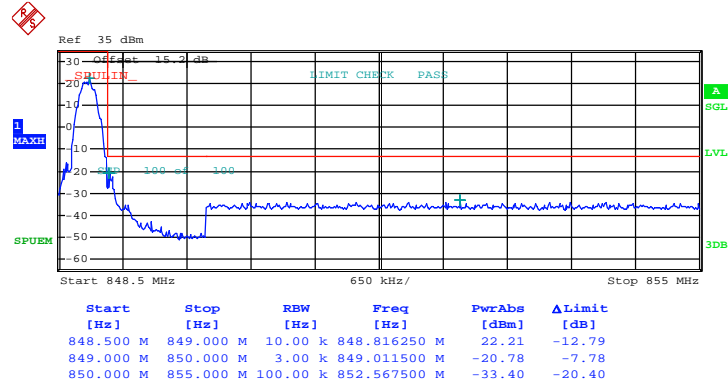



Band :	GSM1900	Test Mode :	GSM Link (GMSK)
--------	---------	-------------	-----------------

Lower Band Edge Plot on Channel 512 (1850.2 MHz)

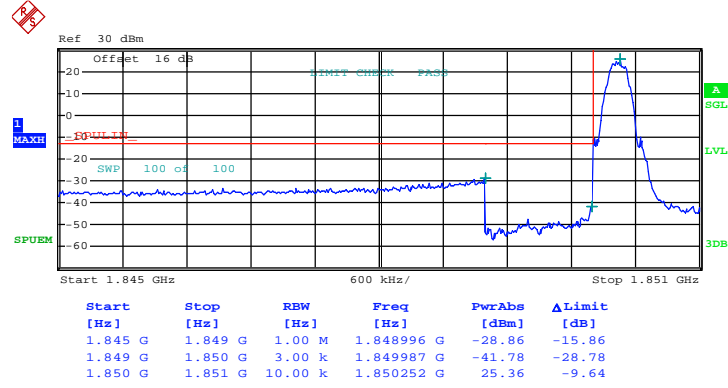



Band :	GSM1900	Test Mode :	GSM Link (GMSK)
--------	---------	-------------	-----------------

Higher Band Edge Plot on Channel 810 (1909.8 MHz)

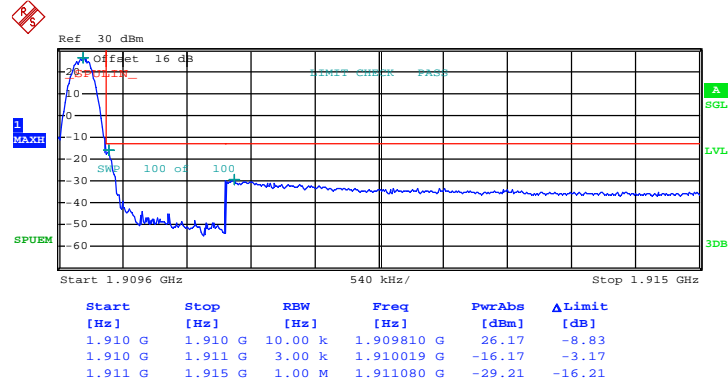



Band :	GSM1900	Test Mode :	EDGE class 8 Link (8PSK)
--------	---------	-------------	--------------------------

Lower Band Edge Plot on Channel 512 (1850.2 MHz)

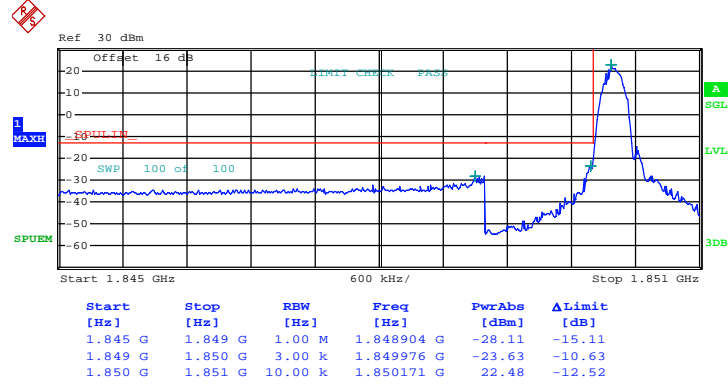



Band :	GSM1900	Test Mode :	EDGE class 8 Link (8PSK)
--------	---------	-------------	--------------------------

Higher Band Edge Plot on Channel 810 (1909.8 MHz)

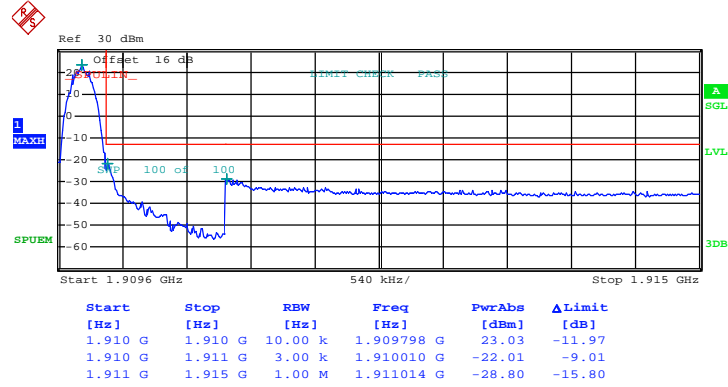



Band :	WCDMA Band V	Test Mode :	RMC 12.2Kbps Link (QPSK)
--------	--------------	-------------	--------------------------

Lower Band Edge Plot on Channel 4132 (826.4 MHz)

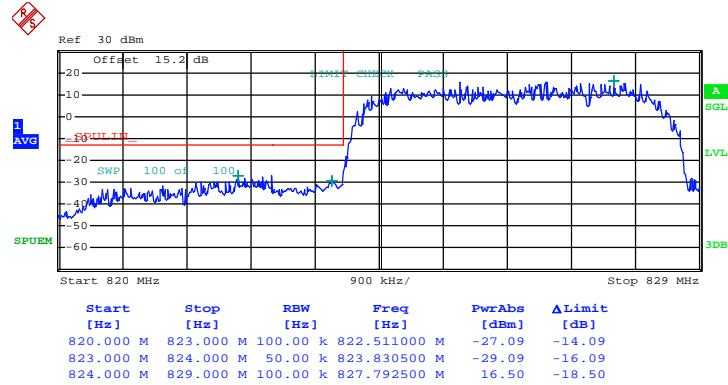



Band :	WCDMA Band V	Test Mode :	RMC 12.2Kbps Link (QPSK)
--------	--------------	-------------	--------------------------

Higher Band Edge Plot on Channel 4233 (846.6 MHz)

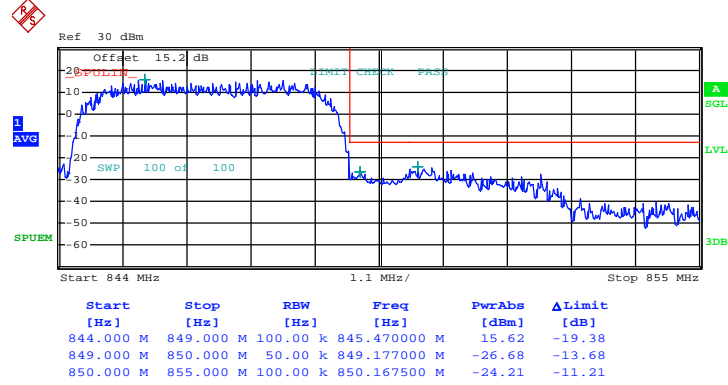



Band :	WCDMA Band IV	Test Mode :	RMC 12.2Kbps Link (QPSK)
--------	---------------	-------------	--------------------------

Lower Band Edge Plot on Channel 1312 (1712.4 MHz)

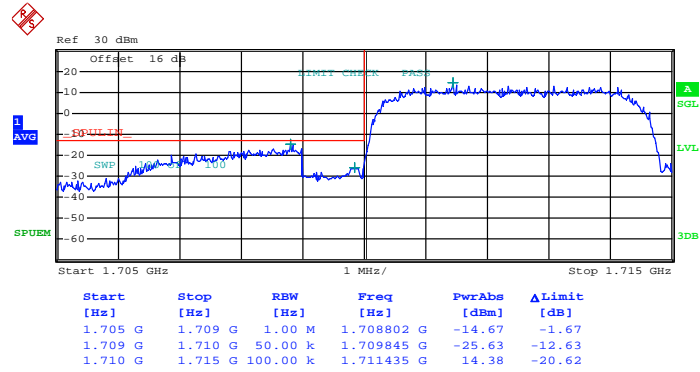



Band :	WCDMA Band IV	Test Mode :	RMC 12.2Kbps Link (QPSK)
--------	---------------	-------------	--------------------------

Higher Band Edge Plot on Channel 1513 (1752.6 MHz)

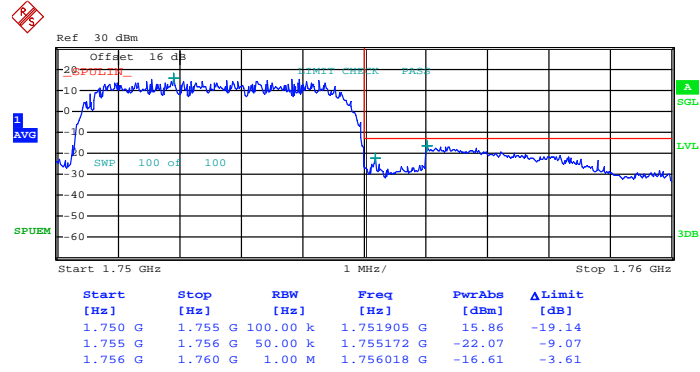



Band :	WCDMA Band II	Test Mode :	RMC 12.2Kbps Link (QPSK)
--------	---------------	-------------	--------------------------

Lower Band Edge Plot on Channel 9262 (1852.4 MHz)

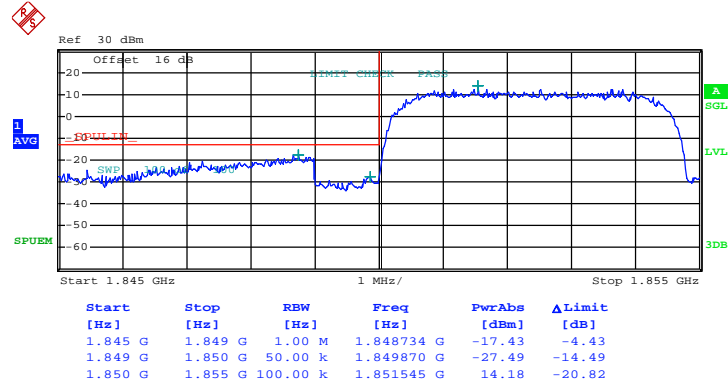



Band :	WCDMA Band II	Test Mode :	RMC 12.2Kbps Link (QPSK)
--------	---------------	-------------	--------------------------

Higher Band Edge Plot on Channel 9538 (1907.6 MHz)

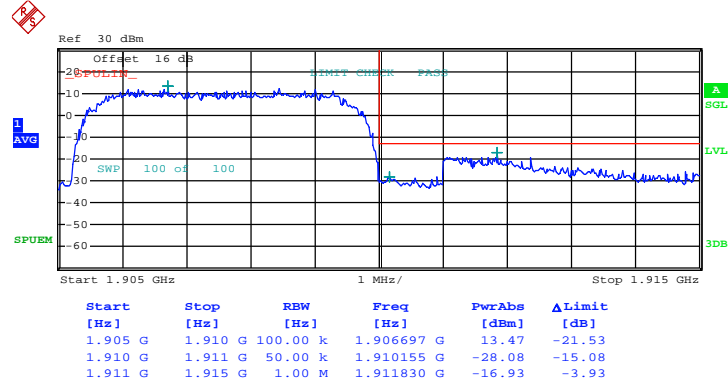

3.6 Conducted Spurious Emission Measurement

3.6.1 Description of Conducted Spurious Emission Measurement

The power of any emission outside of the authorized operating frequency ranges must be lower than the transmitter power (P) by a factor of at least $43 + 10 \log (P)$ dB.

It is measured by means of a calibrated spectrum analyzer and scanned from 30 MHz up to a frequency including its 10th harmonic.

3.6.2 Measuring Instruments

The measuring equipment is listed in the section 4 of this test report.

3.6.3 Test Procedures

1. The testing follows FCC KDB 971168 v02r02 Section 6.0.
2. The EUT was connected to the spectrum analyzer and system simulator via a power divider.
3. The RF output of EUT was connected to the spectrum analyzer by an RF cable and attenuator. The path loss was compensated to the results for each measurement.
4. The middle channel for the highest RF power within the transmitting frequency was measured.
5. The conducted spurious emission for the whole frequency range was taken.
6. The RF fundamental frequency should be excluded against the limit line in the operating frequency band.
7. The limit line is derived from $43 + 10\log(P)$ dB below the transmitter power P(Watts)

$$= P(W) - [43 + 10\log(P)] \text{ (dB)}$$

$$= [30 + 10\log(P)] \text{ (dBm)} - [43 + 10\log(P)] \text{ (dB)}$$

$$= -13\text{dBm}.$$

3.6.4 Test Setup

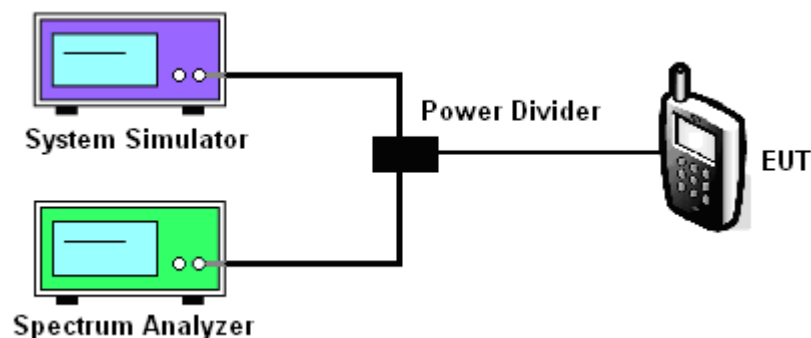



3.6.5 Test Result (Plots) of Conducted Spurious Emission

Band :	GSM850	Channel :	CH128
Test Mode :	GSM Link (GMSK)	Frequency :	824.2 MHz

Conducted Spurious Emission Plot between 30MHz ~ 1GHz

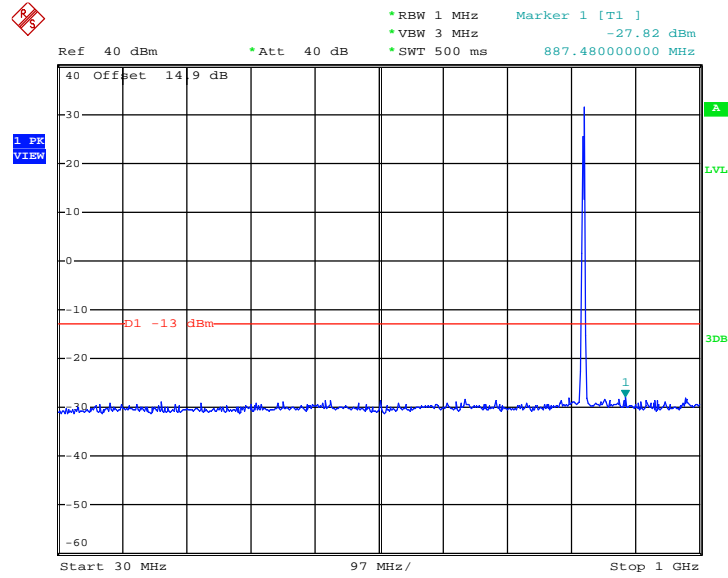

Date: 4.JUN.2015 13:18:31

Conducted Spurious Emission Plot between 1GHz ~ 3GHz

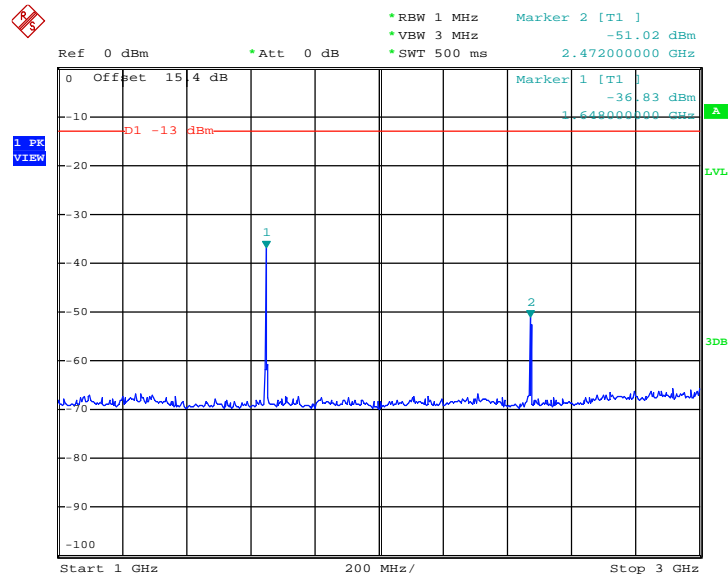

Date: 4.JUN.2015 13:22:16



Conducted Spurious Emission Plot between 3GHz ~ 7GHz

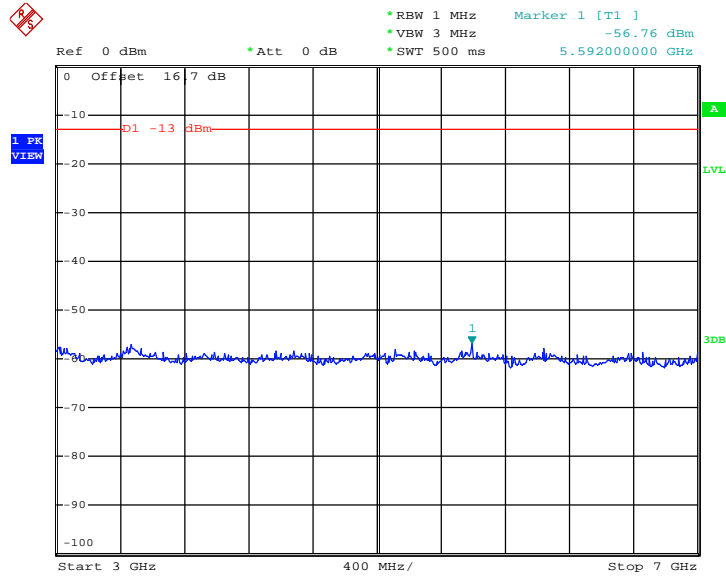

Date: 4.JUN.2015 13:23:31

Conducted Spurious Emission Plot between 7GHz ~ 9GHz

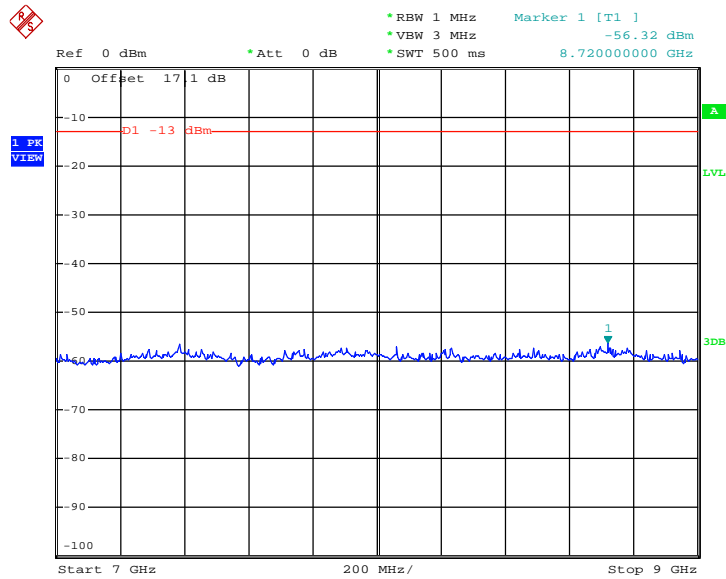

Date: 4.JUN.2015 13:25:42



Band :	GSM850	Channel :	CH189
Test Mode :	GSM Link (GMSK)	Frequency :	836.4 MHz

Conducted Spurious Emission Plot between 30MHz ~ 1GHz

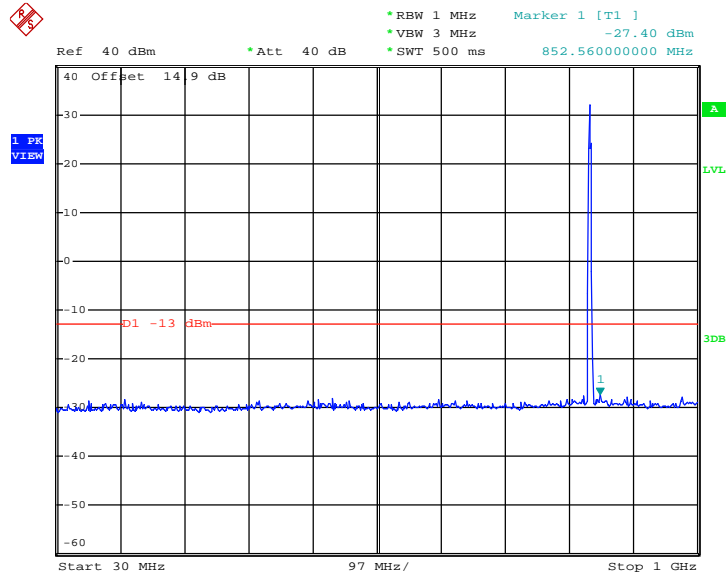

Conducted Spurious Emission Plot between 1GHz ~ 3GHz

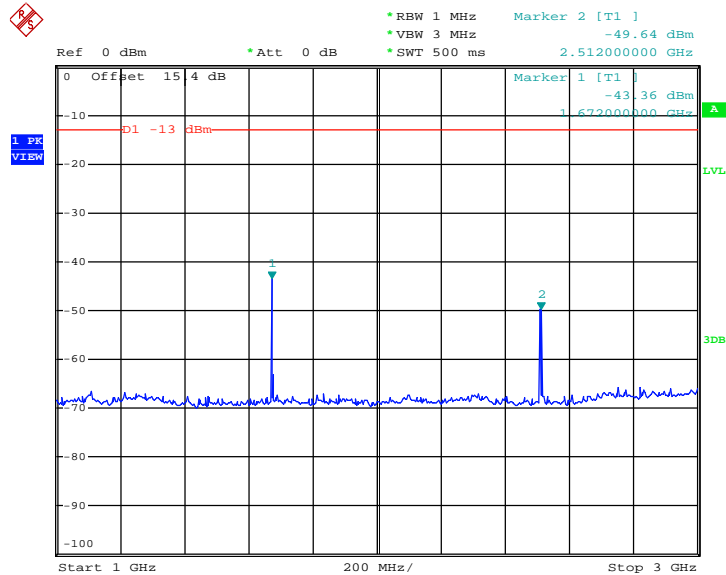



Conducted Spurious Emission Plot between 3GHz ~ 7GHz

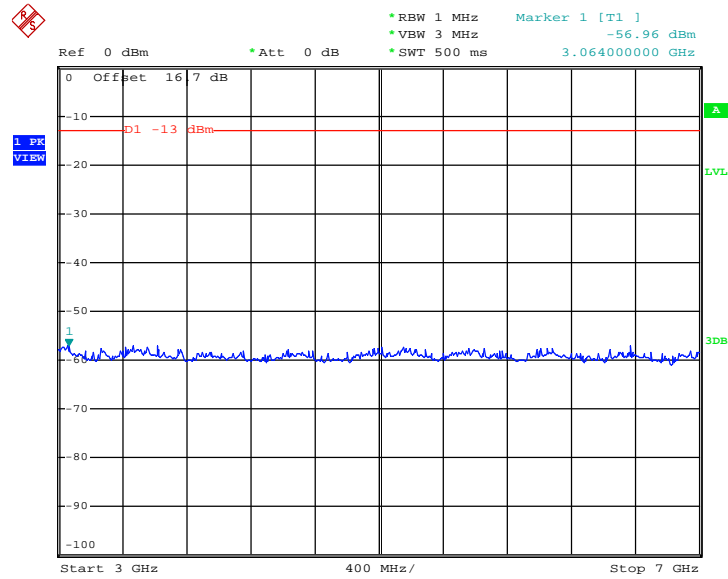

Conducted Spurious Emission Plot between 7GHz ~ 9GHz

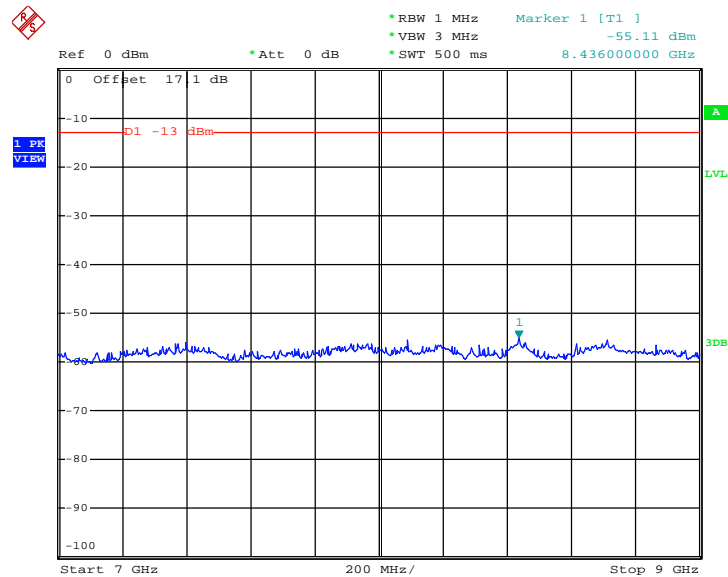



Band :	GSM850	Channel :	CH251
Test Mode :	GSM Link (GMSK)	Frequency :	848.8 MHz

Conducted Spurious Emission Plot between 30MHz ~ 1GHz

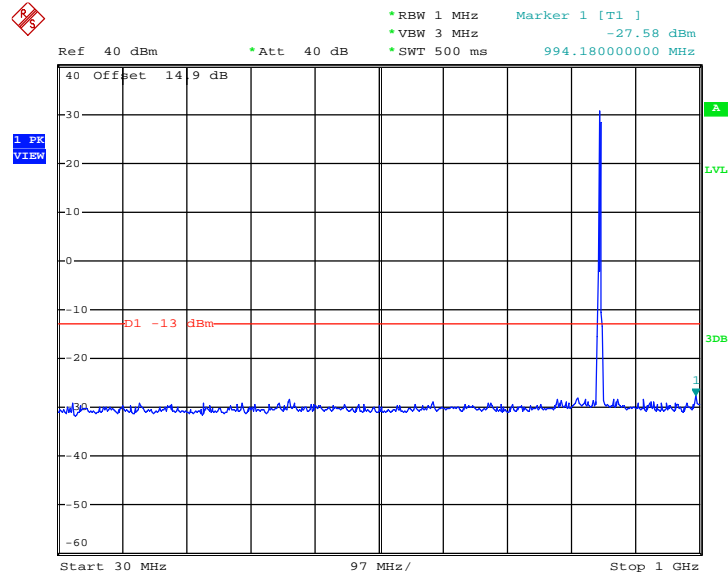

Date: 4.JUN.2015 13:19:30

Conducted Spurious Emission Plot between 1GHz ~ 3GHz

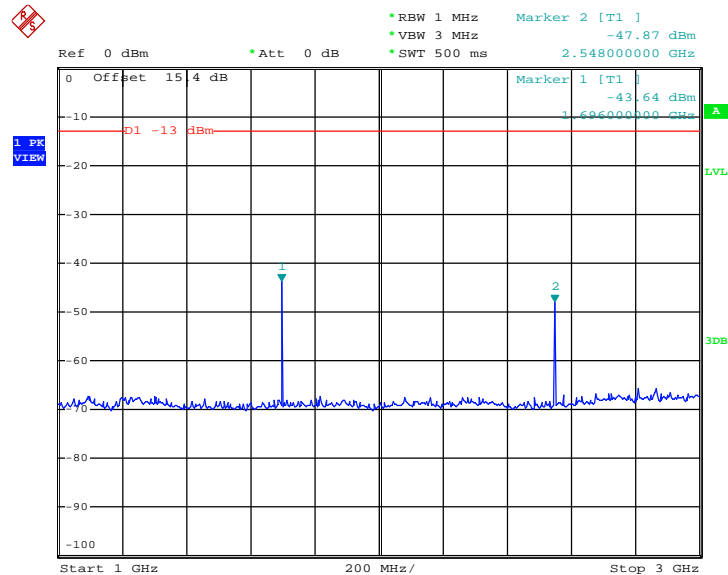

Date: 4.JUN.2015 13:21:32



Conducted Spurious Emission Plot between 3GHz ~ 7GHz

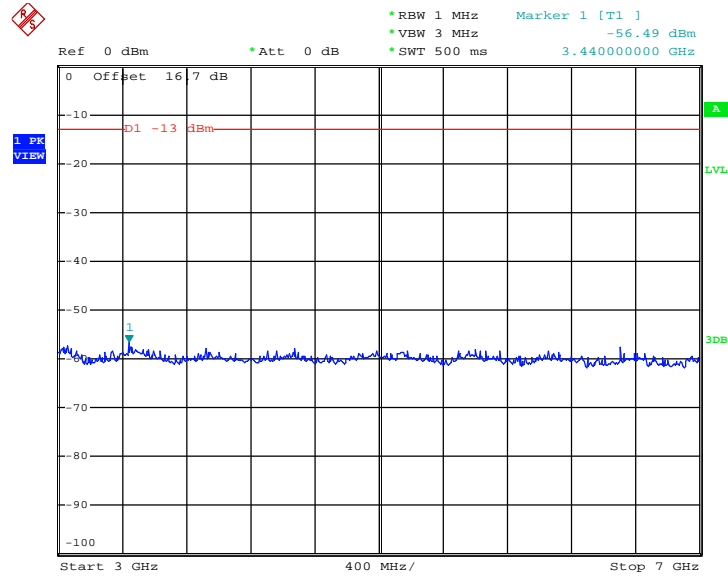

Date: 4.JUN.2015 13:23:56

Conducted Spurious Emission Plot between 7GHz ~ 9GHz

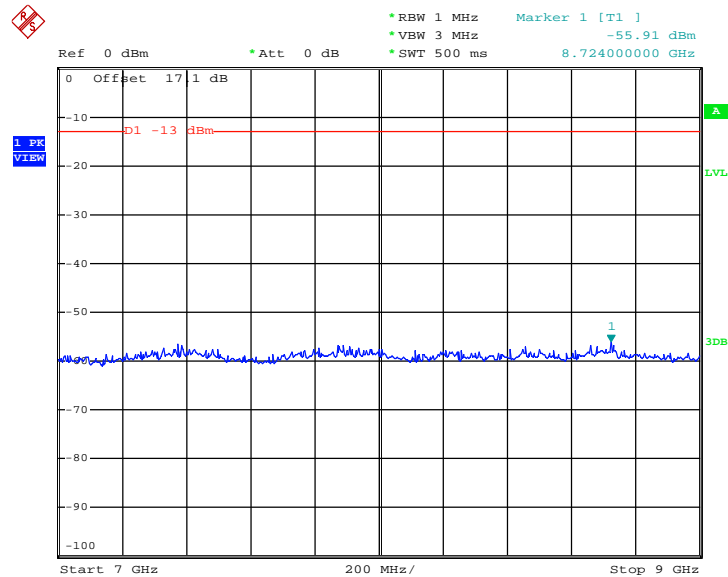

Date: 4.JUN.2015 13:24:59



Band :	GSM850	Channel :	CH128
Test Mode :	EDGE class 8 Link (8PSK)	Frequency :	824.2 MHz

Conducted Spurious Emission Plot between 30MHz ~ 1GHz

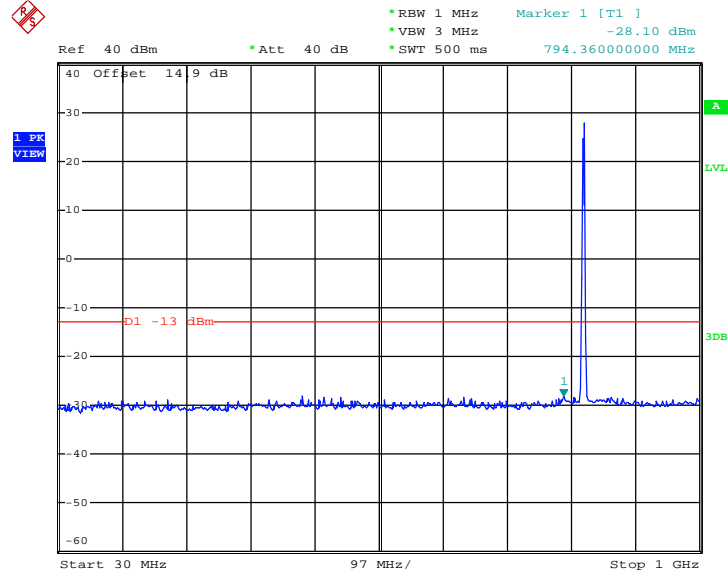

Date: 4.JUN.2015 13:34:46

Conducted Spurious Emission Plot between 1GHz ~ 3GHz

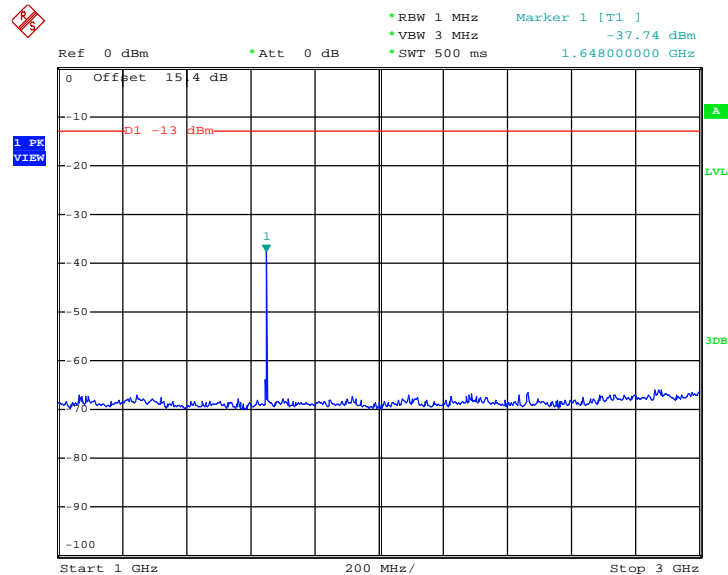

Date: 4.JUN.2015 13:31:06



Conducted Spurious Emission Plot between 3GHz ~ 7GHz

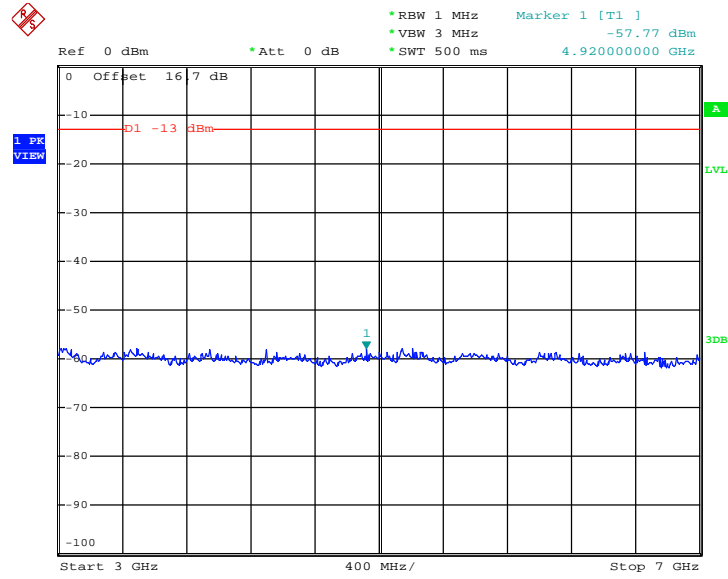

Date: 4.JUN.2015 13:30:18

Conducted Spurious Emission Plot between 7GHz ~ 9GHz

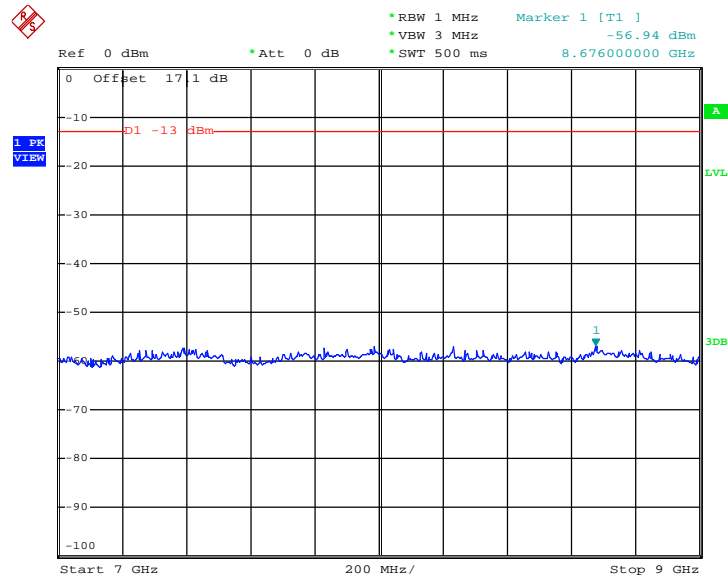

Date: 4.JUN.2015 13:28:22



Band :	GSM850	Channel :	CH189
Test Mode :	EDGE class 8 Link (8PSK)	Frequency :	836.4 MHz

Conducted Spurious Emission Plot between 30MHz ~ 1GHz

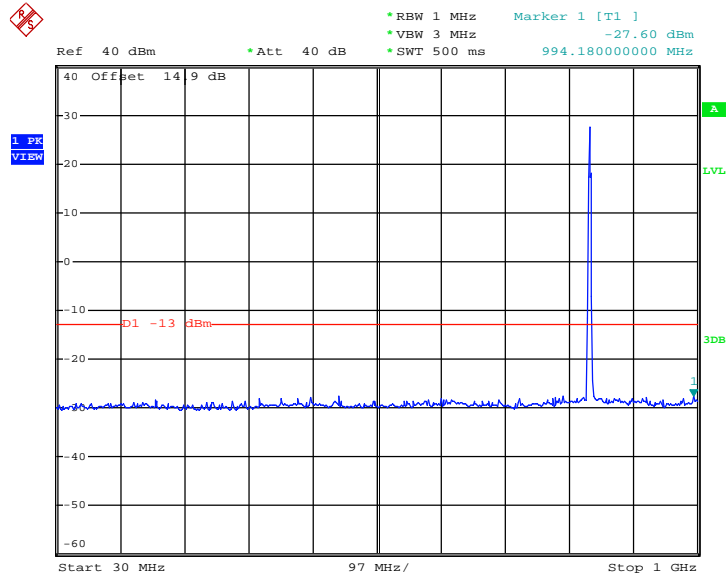

Conducted Spurious Emission Plot between 1GHz ~ 3GHz

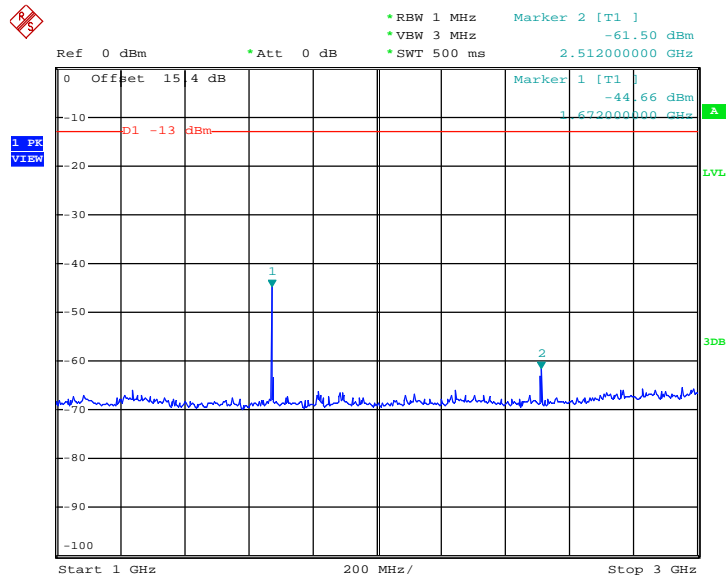



Conducted Spurious Emission Plot between 3GHz ~ 7GHz

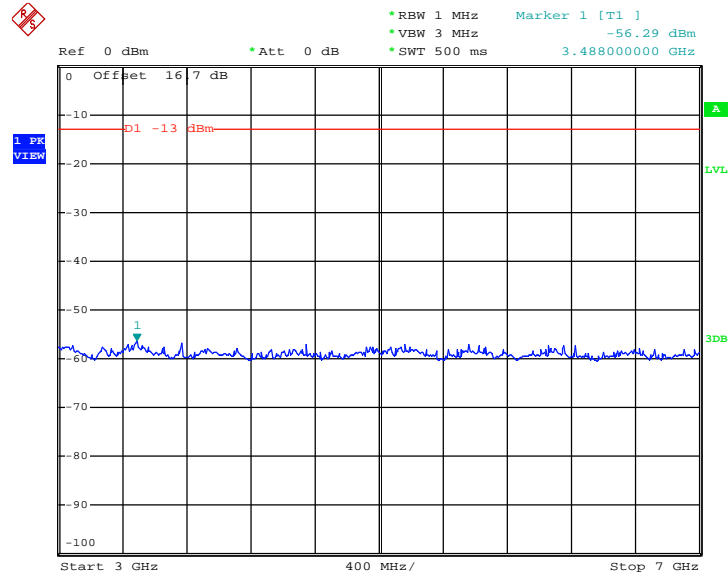

Conducted Spurious Emission Plot between 7GHz ~ 9GHz

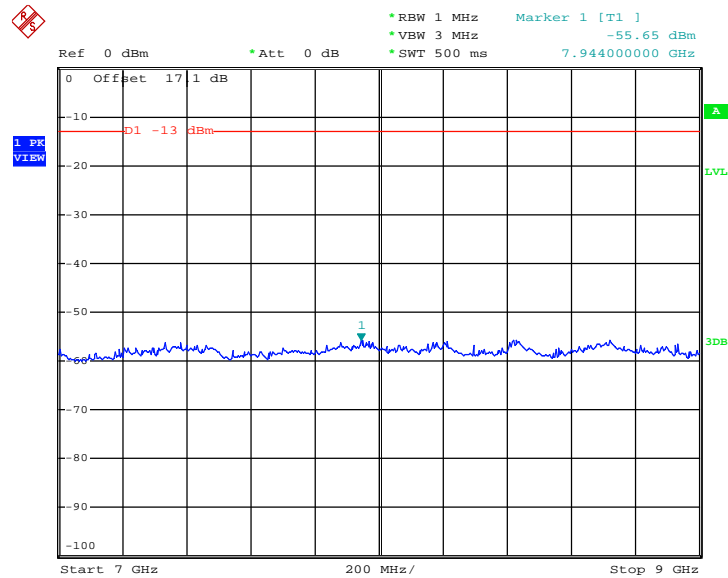



Band :	GSM850	Channel :	CH251
Test Mode :	EDGE class 8 Link (8PSK)	Frequency :	848.8 MHz

Conducted Spurious Emission Plot between 30MHz ~ 1GHz

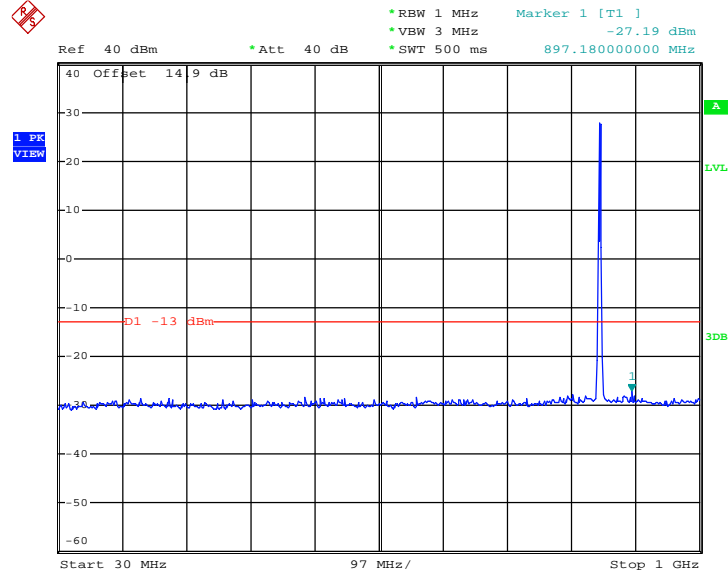

Date: 4.JUN.2015 13:33:56

Conducted Spurious Emission Plot between 1GHz ~ 3GHz

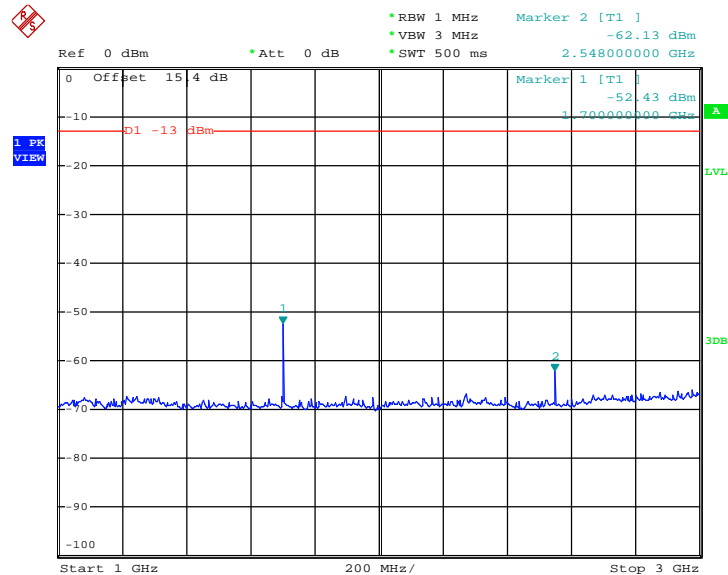

Date: 4.JUN.2015 13:31:53



Conducted Spurious Emission Plot between 3GHz ~ 7GHz

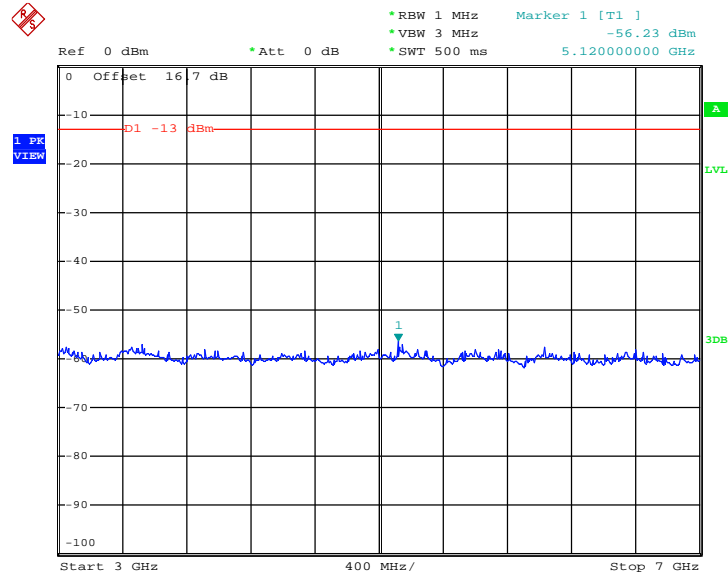

Date: 4.JUN.2015 13:29:34

Conducted Spurious Emission Plot between 7GHz ~ 9GHz

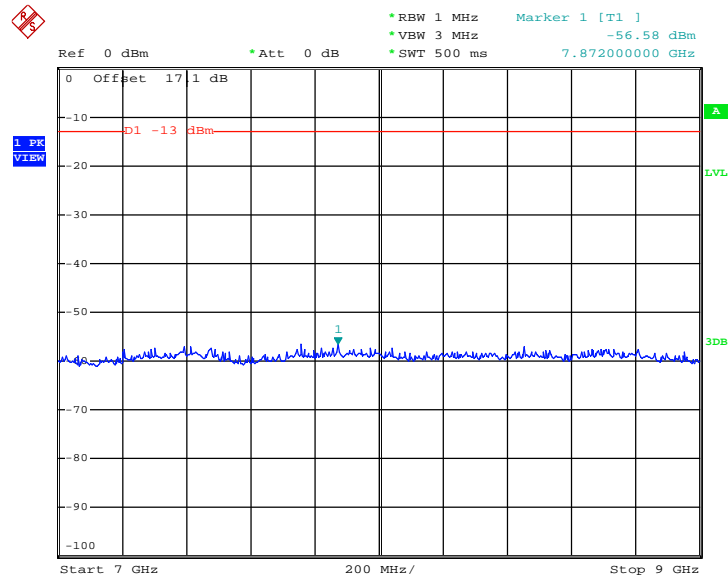

Date: 4.JUN.2015 13:28:46



Band :	GSM1900	Channel :	CH512
Test Mode :	GSM Link (GMSK)	Frequency :	1850.2 MHz

Conducted Spurious Emission Plot between 30MHz ~ 1GHz

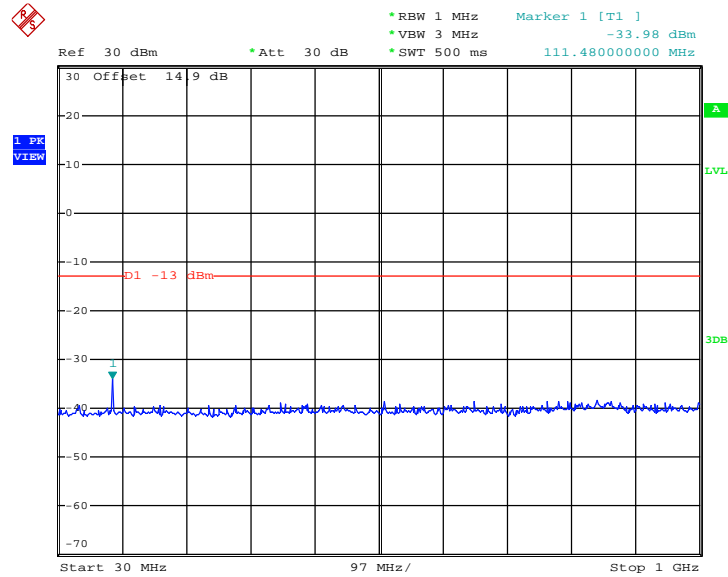

Date: 4.JUN.2015 14:14:03

Conducted Spurious Emission Plot between 1GHz ~ 3GHz

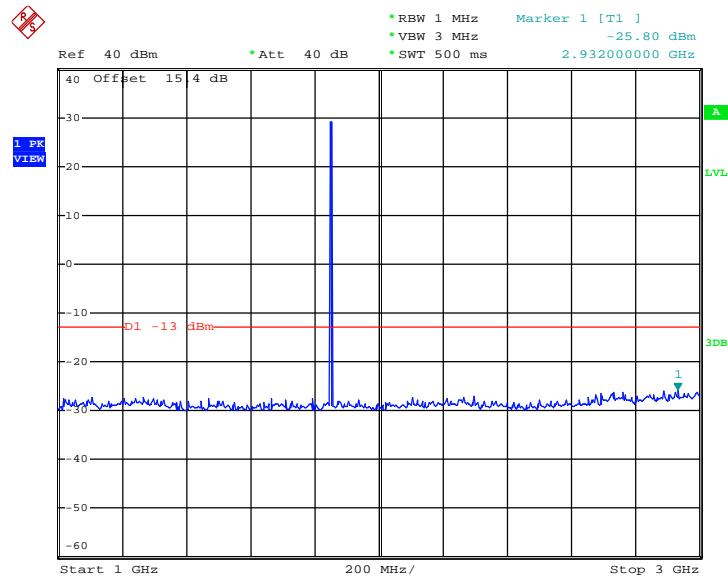

Date: 4.JUN.2015 14:13:13



Conducted Spurious Emission Plot between 3GHz ~ 7GHz

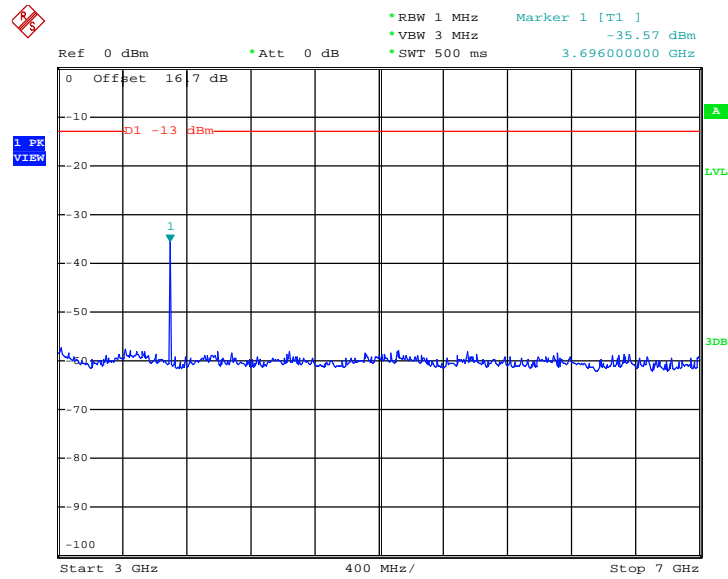

Date: 4.JUN.2015 14:10:29

Conducted Spurious Emission Plot between 7GHz ~ 13.6GHz

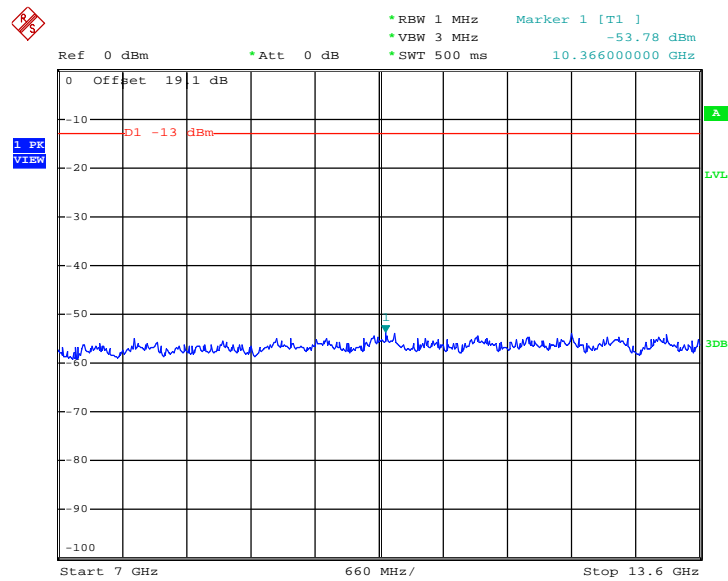

Date: 4.JUN.2015 14:09:32



Conducted Spurious Emission Plot between 13.6GHz ~ 19.1GHz

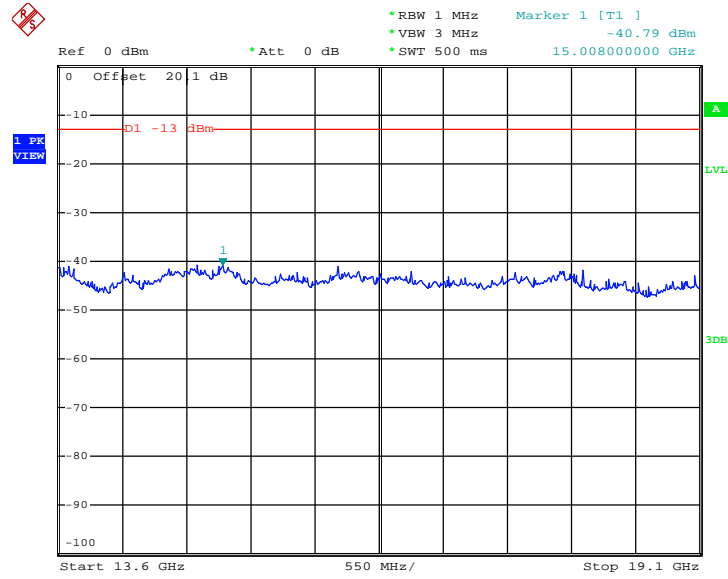

Date: 4.JUN.2015 14:07:20



Band :	GSM1900	Channel :	CH661
Test Mode :	GSM Link (GMSK)	Frequency :	1880.0 MHz

Conducted Spurious Emission Plot between 30MHz ~ 1GHz

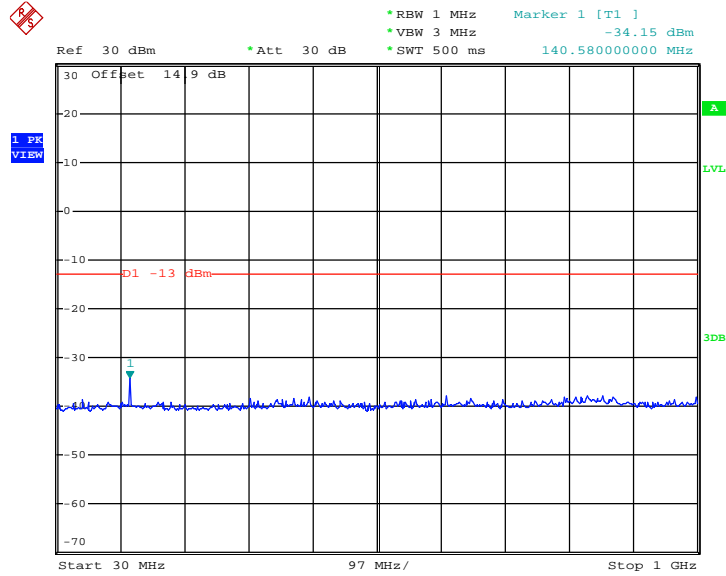

Conducted Spurious Emission Plot between 1GHz ~ 3GHz

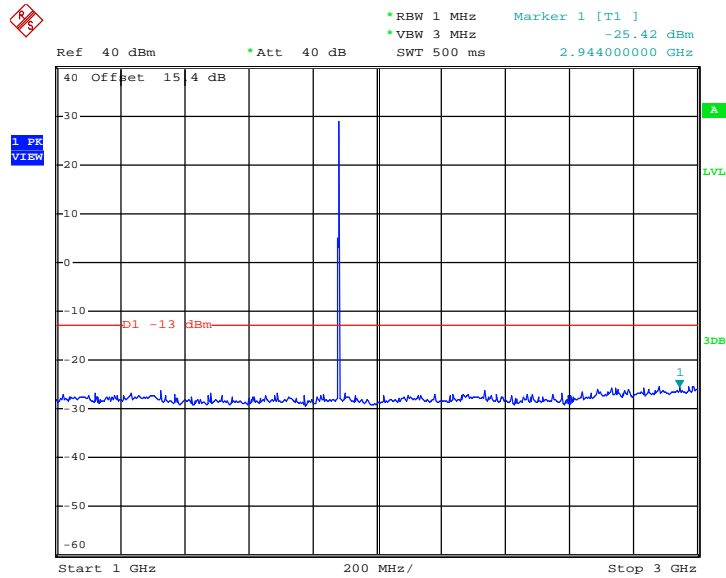



Conducted Spurious Emission Plot between 3GHz ~ 7GHz

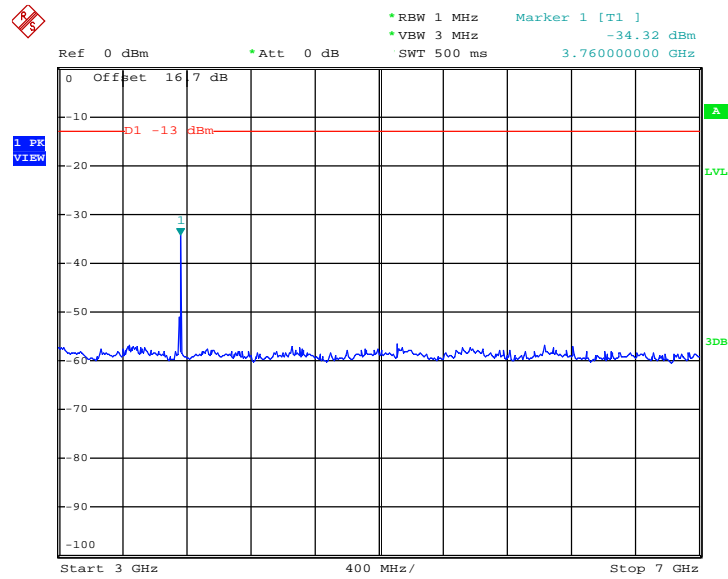

Conducted Spurious Emission Plot between 7GHz ~ 13.6GHz

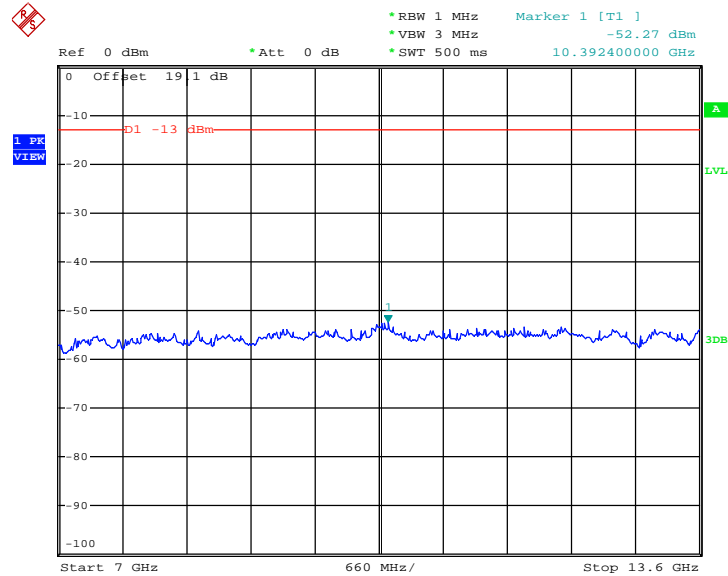



Conducted Spurious Emission Plot between 13.6GHz ~ 19.1GHz

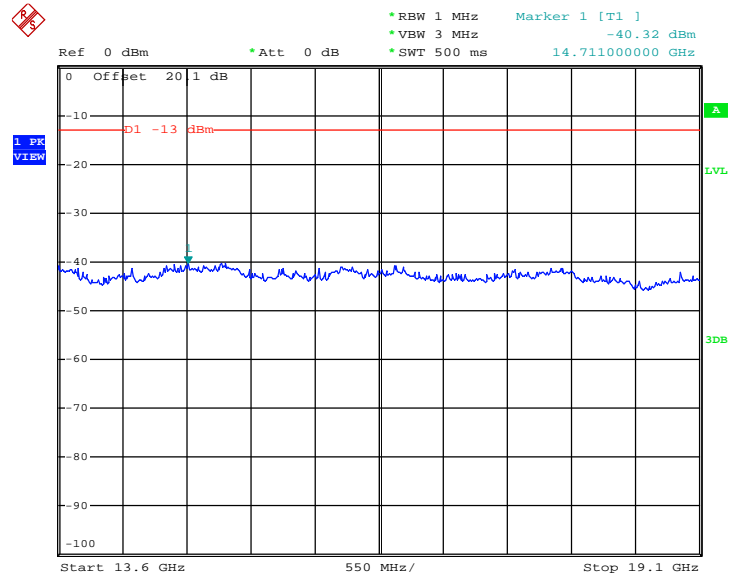



Band :	GSM1900	Channel :	CH810
Test Mode :	GSM Link (GMSK)	Frequency :	1909.8 MHz

Conducted Spurious Emission Plot between 30MHz ~ 1GHz

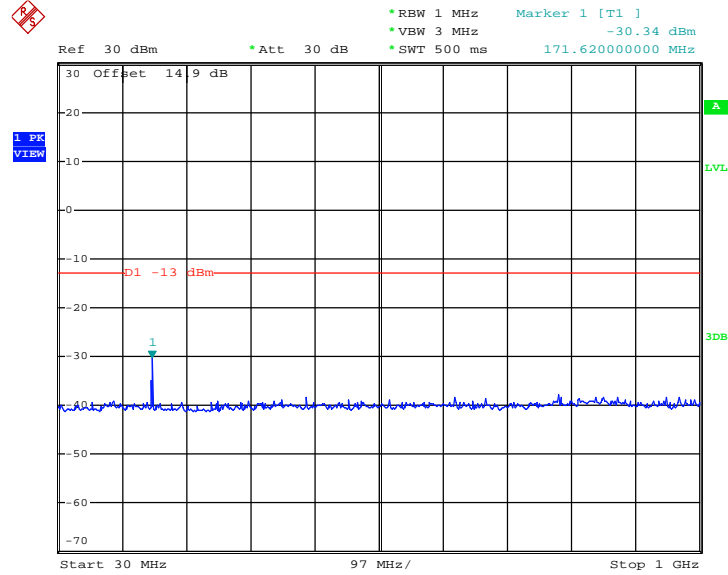

Date: 4.JUN.2015 14:14:32

Conducted Spurious Emission Plot between 1GHz ~ 3GHz

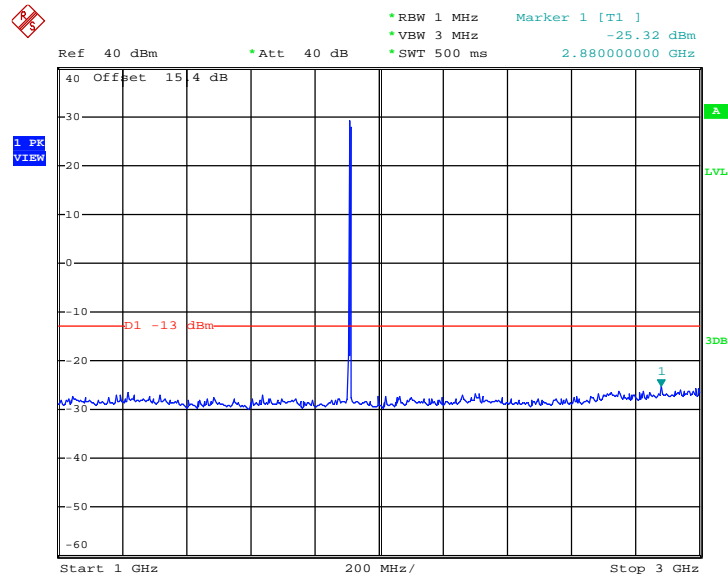

Date: 4.JUN.2015 14:12:37



Conducted Spurious Emission Plot between 3GHz ~ 7GHz

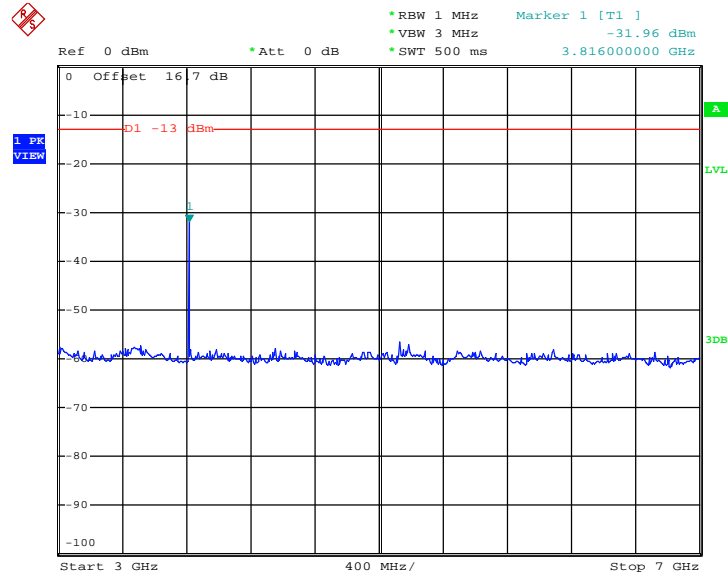

Date: 4.JUN.2015 14:10:53

Conducted Spurious Emission Plot between 7GHz ~ 13.6GHz

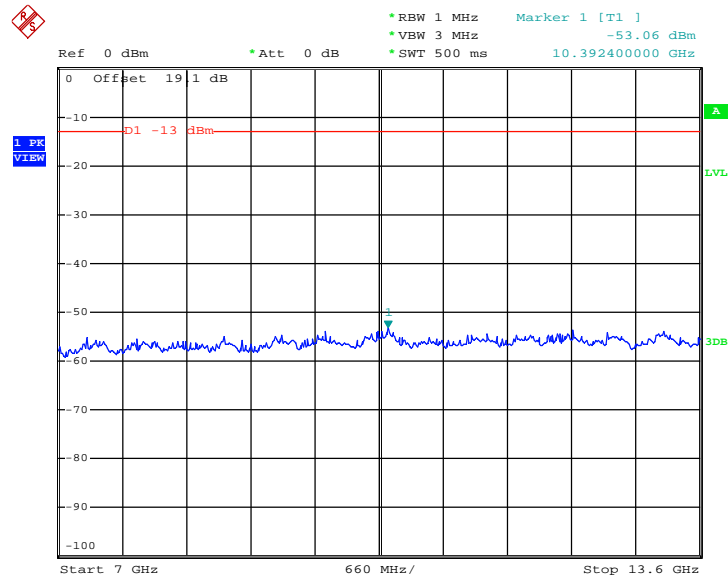

Date: 4.JUN.2015 14:08:59



Conducted Spurious Emission Plot between 13.6GHz ~ 19.1GHz

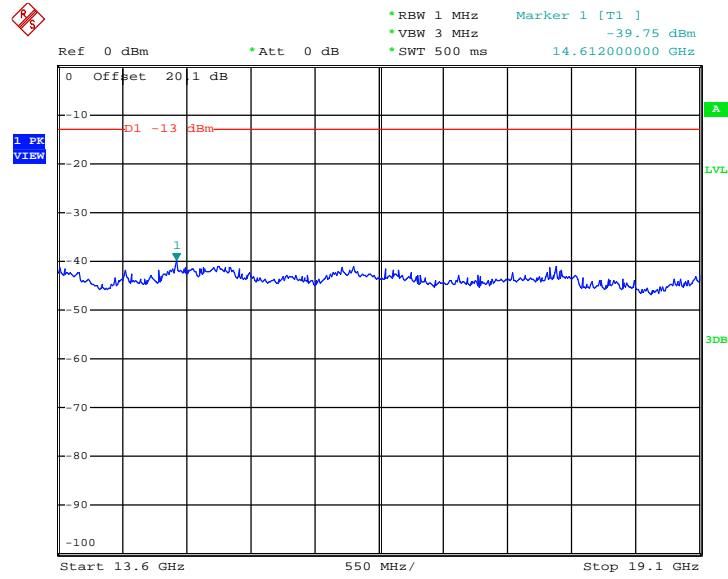

Date: 4.JUN.2015 14:07:51



Band :	GSM1900	Channel :	CH512
Test Mode :	EDGE class 8 Link (8PSK)	Frequency :	1850.2 MHz

Conducted Spurious Emission Plot between 30MHz ~ 1GHz

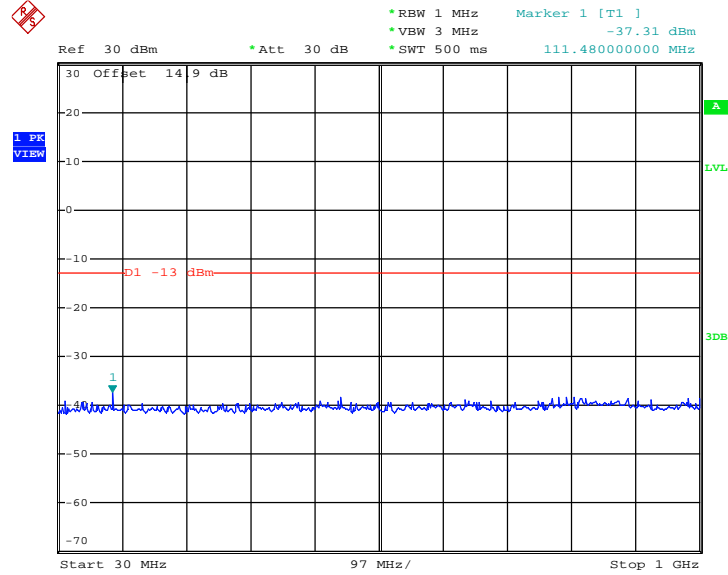

Date: 4.JUN.2015 14:19:43

Conducted Spurious Emission Plot between 1GHz ~ 3GHz

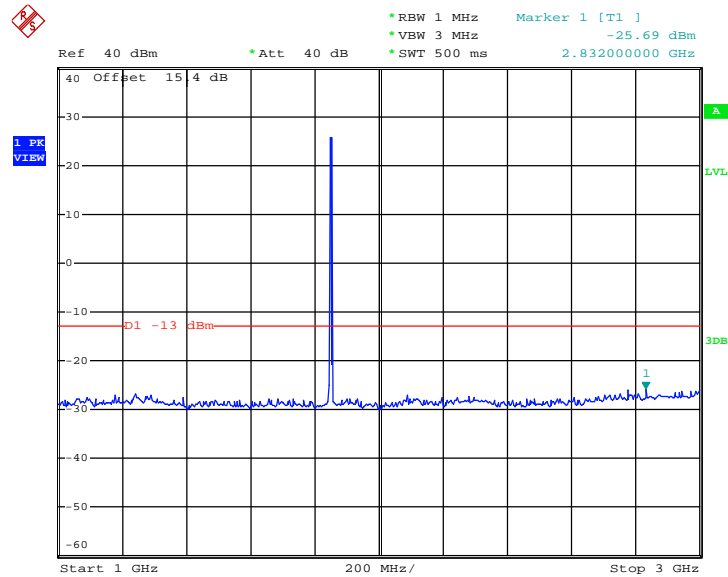

Date: 4.JUN.2015 14:20:54



Conducted Spurious Emission Plot between 3GHz ~ 7GHz

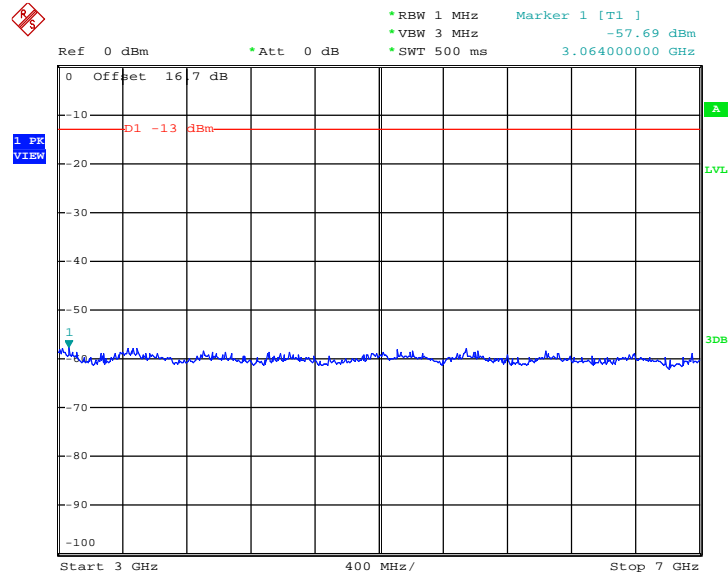

Date: 4.JUN.2015 14:24:00

Conducted Spurious Emission Plot between 7GHz ~ 13.6GHz

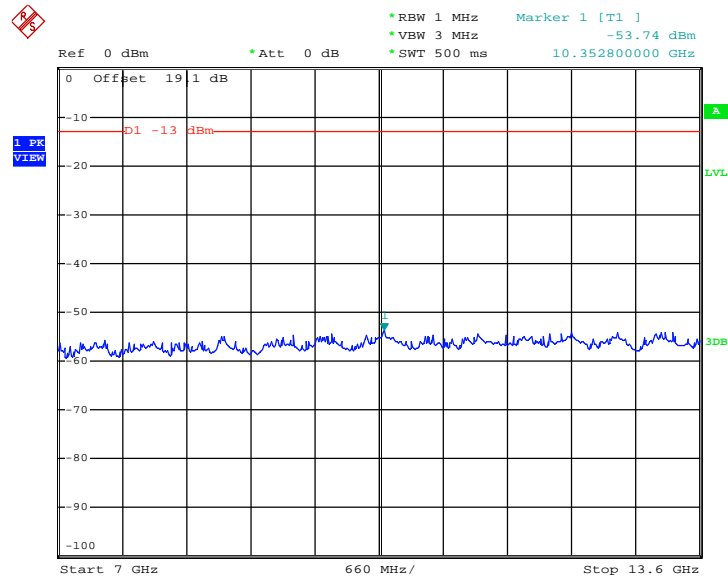

Date: 4.JUN.2015 14:24:52



Conducted Spurious Emission Plot between 13.6GHz ~ 19.1GHz

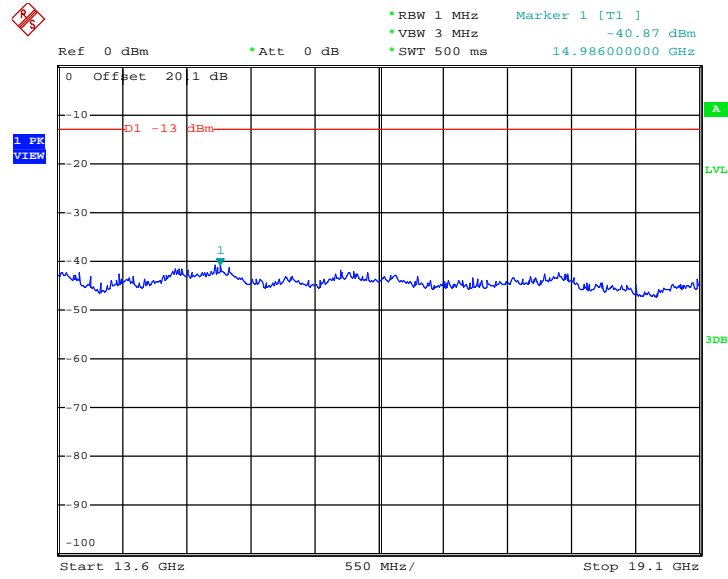

Date: 4.JUN.2015 14:29:26



Band :	GSM1900	Channel :	CH661
Test Mode :	EDGE class 8 Link (8PSK)	Frequency :	1880.0 MHz

Conducted Spurious Emission Plot between 30MHz ~ 1GHz

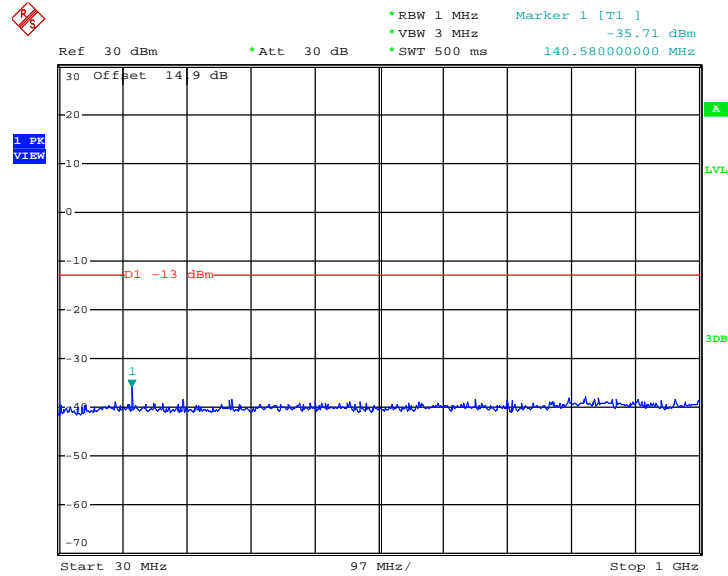

Conducted Spurious Emission Plot between 1GHz ~ 3GHz

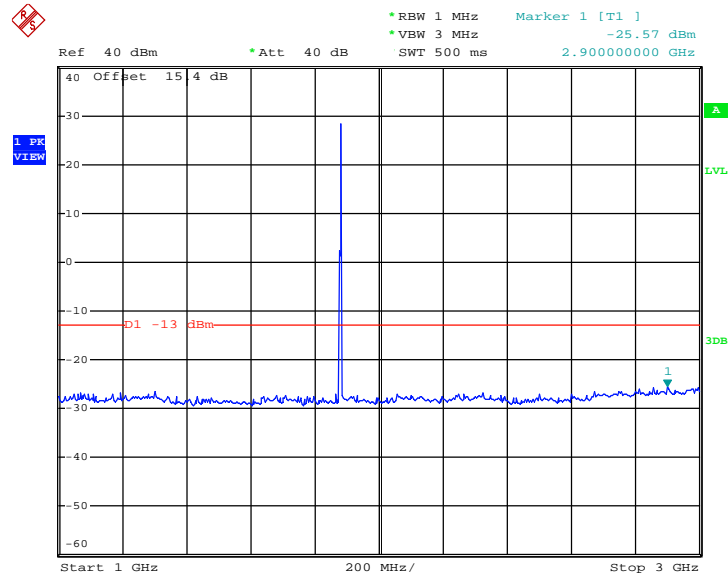



Conducted Spurious Emission Plot between 3GHz ~ 7GHz

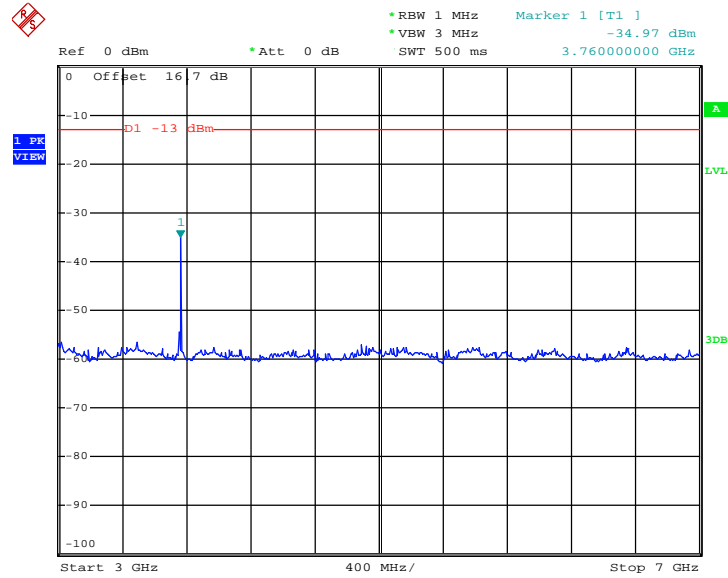

Conducted Spurious Emission Plot between 7GHz ~ 13.6GHz

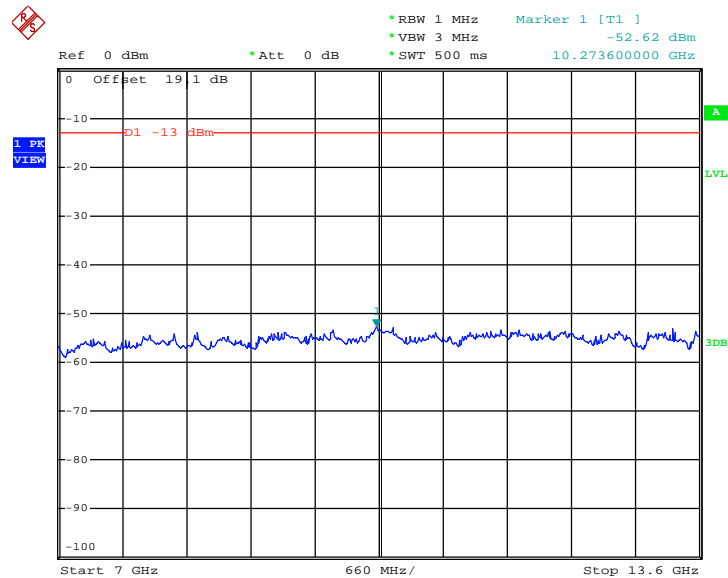



Conducted Spurious Emission Plot between 13.6GHz ~ 19.1GHz

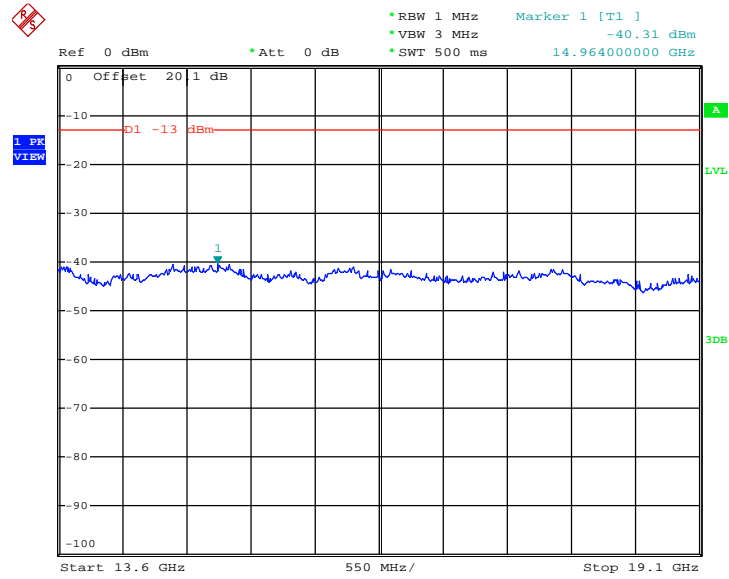



Band :	GSM1900	Channel :	CH810
Test Mode :	EDGE class 8 Link (8PSK)	Frequency :	1909.8 MHz

Conducted Spurious Emission Plot between 30MHz ~ 1GHz

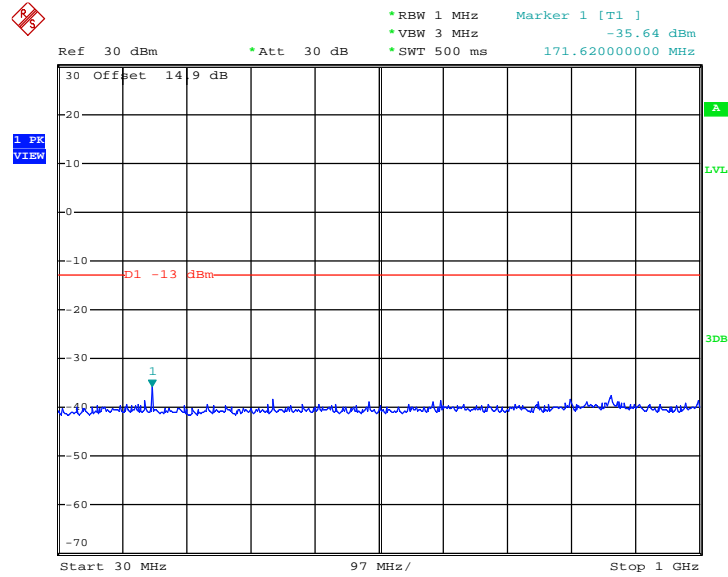

Date: 4.JUN.2015 14:19:13

Conducted Spurious Emission Plot between 1GHz ~ 3GHz

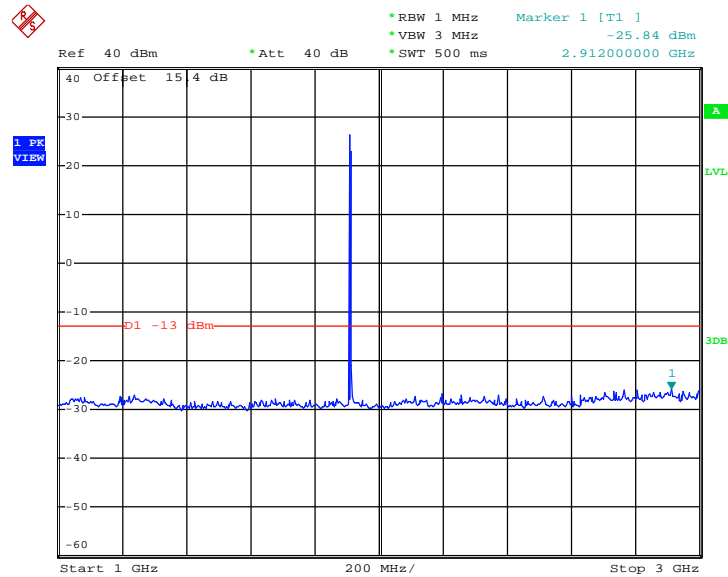

Date: 4.JUN.2015 14:21:32



Conducted Spurious Emission Plot between 3GHz ~ 7GHz

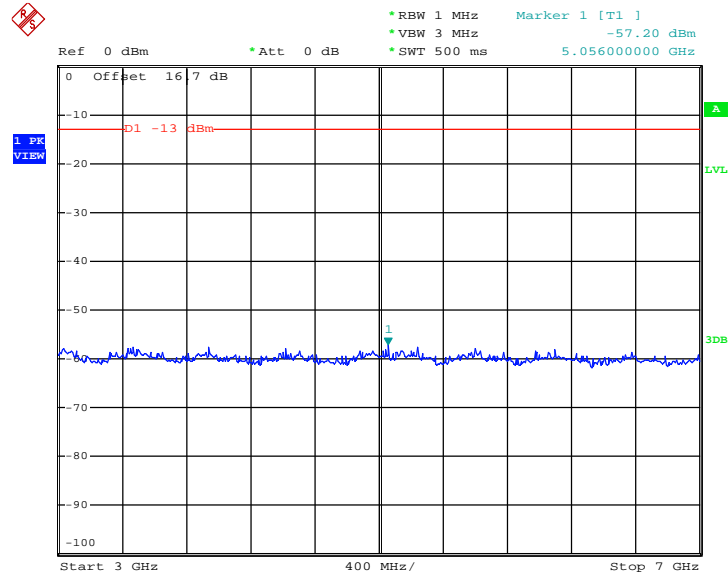

Date: 4.JUN.2015 14:23:24

Conducted Spurious Emission Plot between 7GHz ~ 13.6GHz

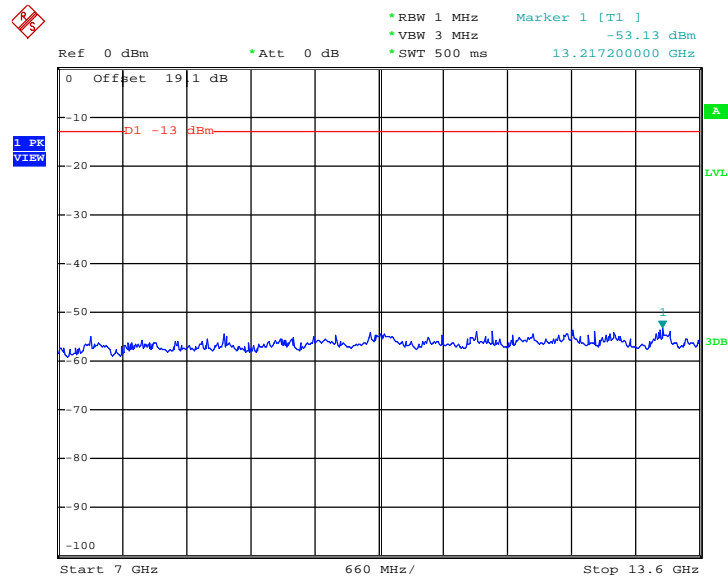

Date: 4.JUN.2015 14:25:21



Conducted Spurious Emission Plot between 13.6GHz ~ 19.1GHz

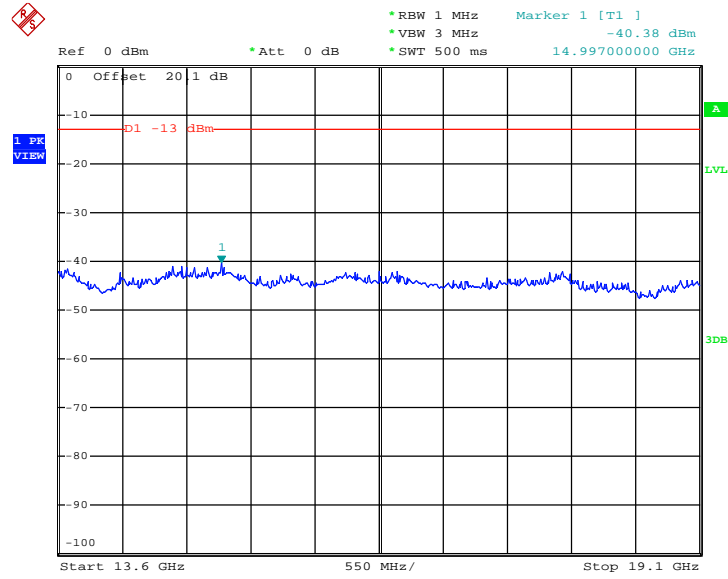

Date: 4.JUN.2015 14:29:51



Band :	WCDMA Band V	Channel :	CH4132
Test Mode :	RMC 12.2Kbps Link (QPSK)	Frequency :	826.4 MHz

Conducted Spurious Emission Plot between 30MHz ~ 1GHz

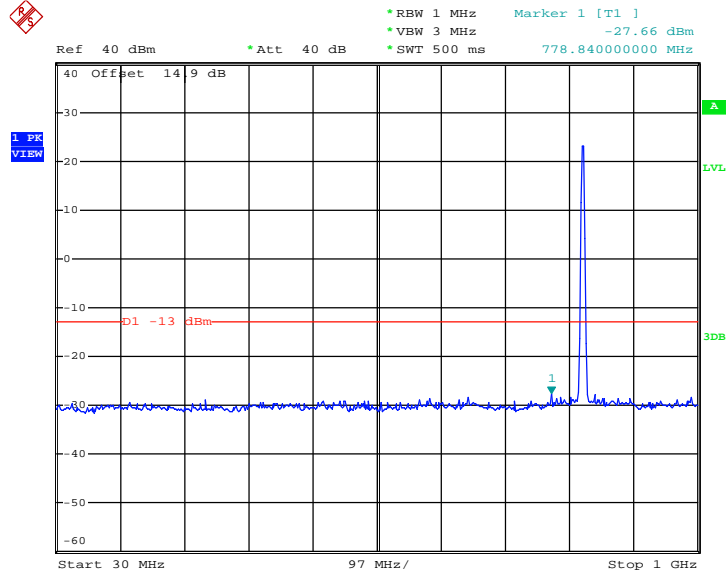

Date: 4.JUN.2015 13:40:05

Conducted Spurious Emission Plot between 1GHz ~ 3GHz

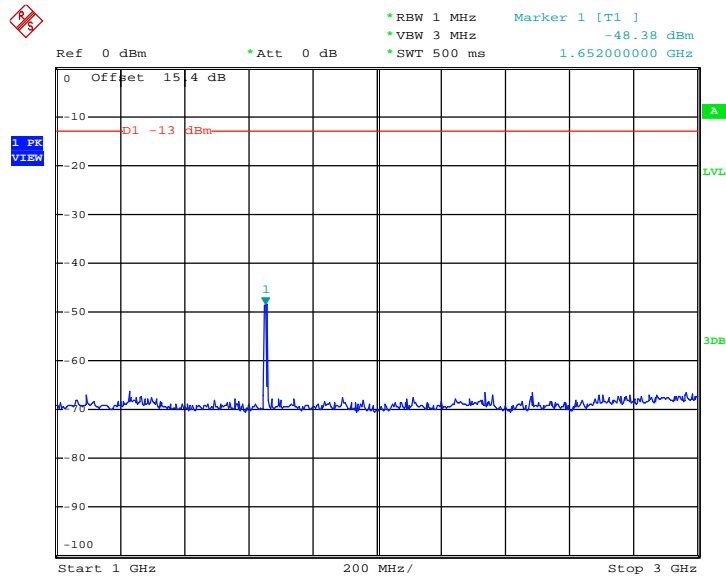

Date: 4.JUN.2015 13:46:20



Conducted Spurious Emission Plot between 3GHz ~ 7GHz

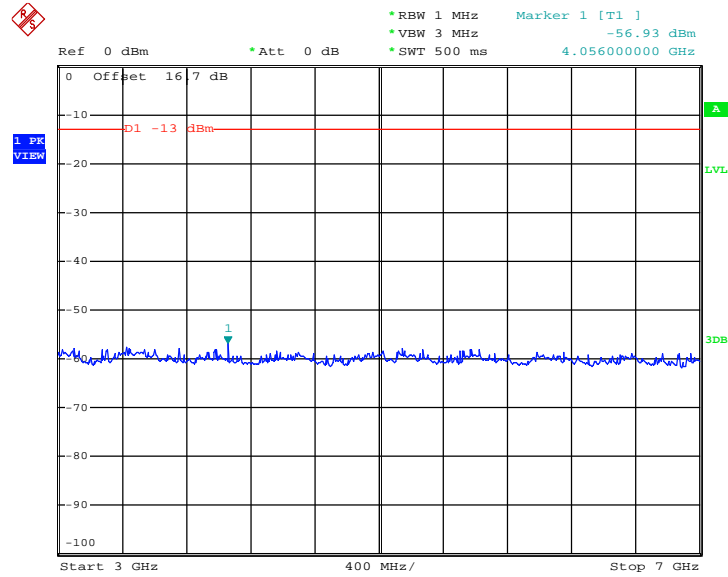

Date: 4.JUN.2015 13:47:21

Conducted Spurious Emission Plot between 7GHz ~ 9GHz

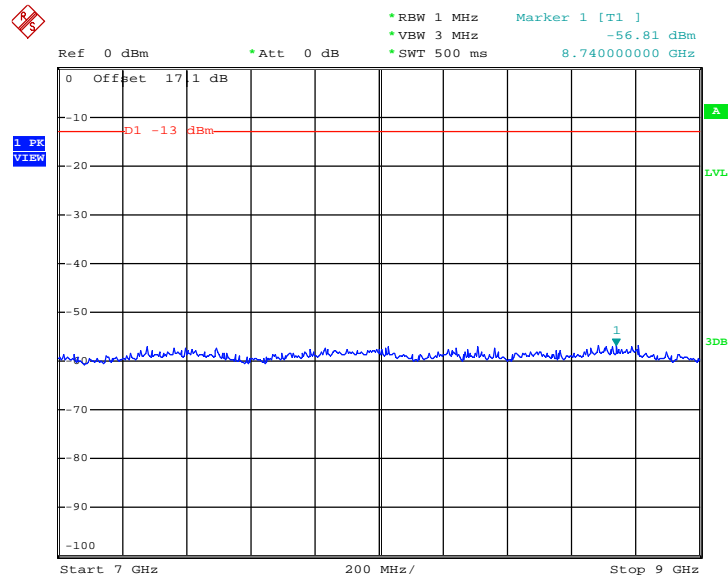

Date: 4.JUN.2015 13:49:04



Band :	WCDMA Band V	Channel :	CH4182
Test Mode :	RMC 12.2Kbps Link (QPSK)	Frequency :	836.4 MHz

Conducted Spurious Emission Plot between 30MHz ~ 1GHz

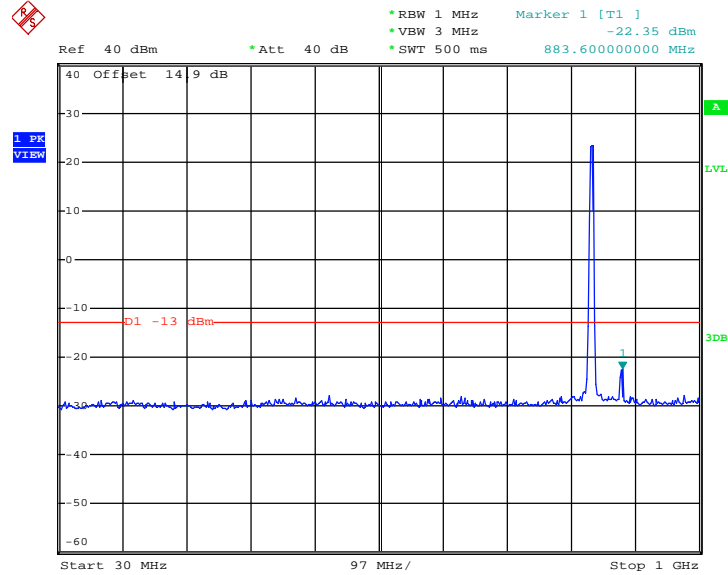

Conducted Spurious Emission Plot between 1GHz ~ 3GHz

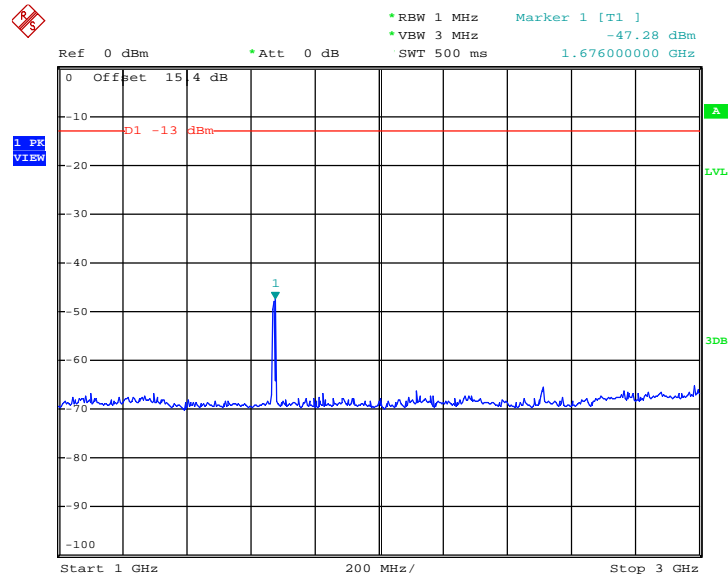



Conducted Spurious Emission Plot between 3GHz ~ 7GHz

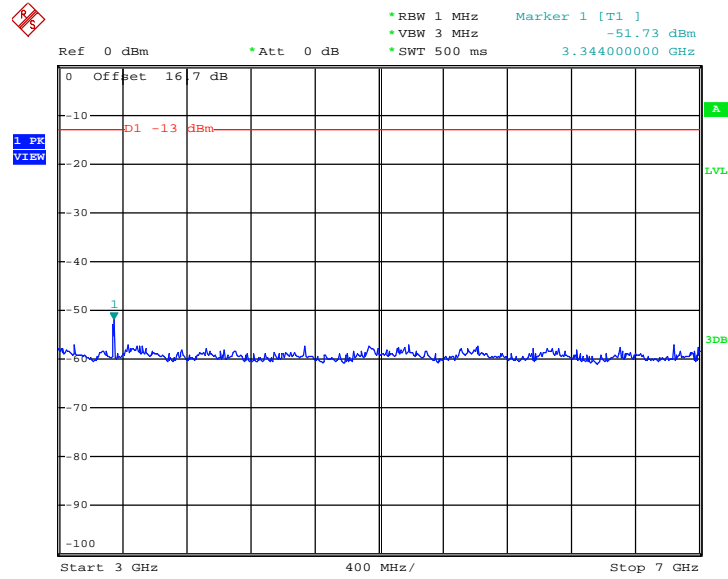

Conducted Spurious Emission Plot between 7GHz ~ 9GHz

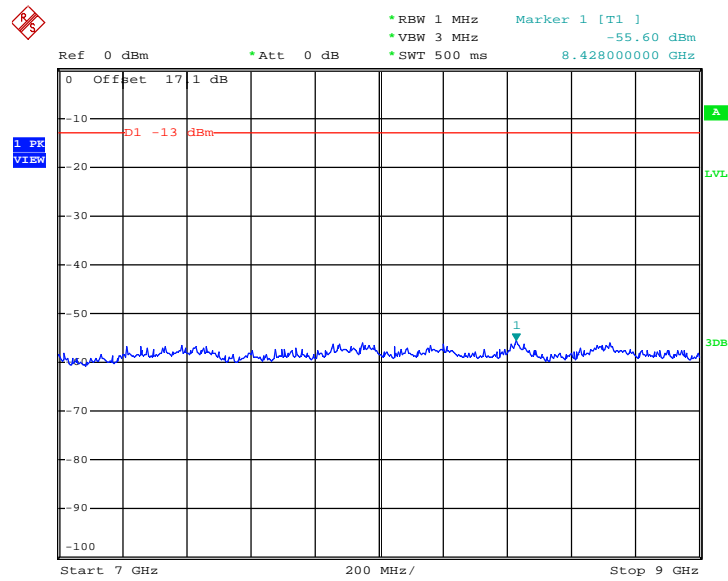



Band :	WCDMA Band V	Channel :	CH4233
Test Mode :	RMC 12.2Kbps Link (QPSK)	Frequency :	846.6 MHz

Conducted Spurious Emission Plot between 30MHz ~ 1GHz

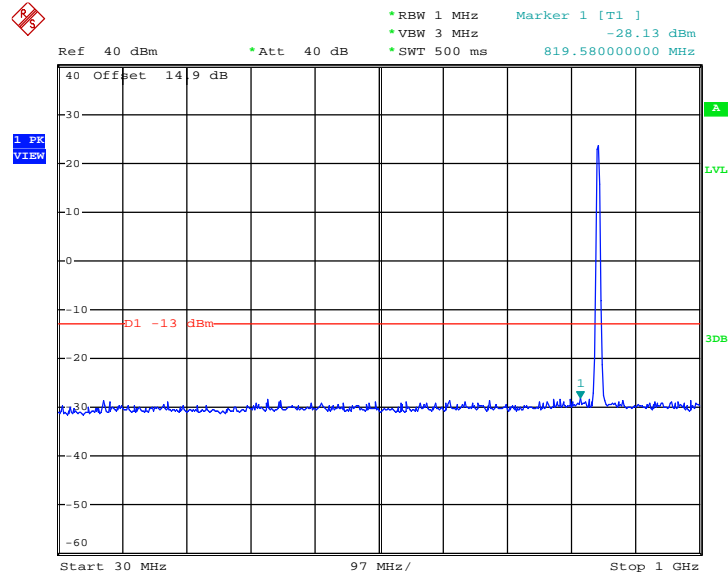

Date: 4.JUN.2015 13:40:53

Conducted Spurious Emission Plot between 1GHz ~ 3GHz

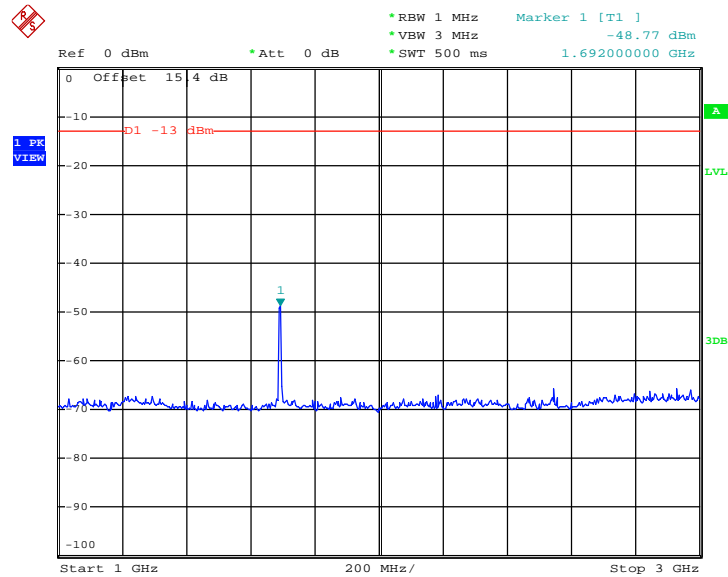

Date: 4.JUN.2015 13:45:11



Conducted Spurious Emission Plot between 3GHz ~ 7GHz

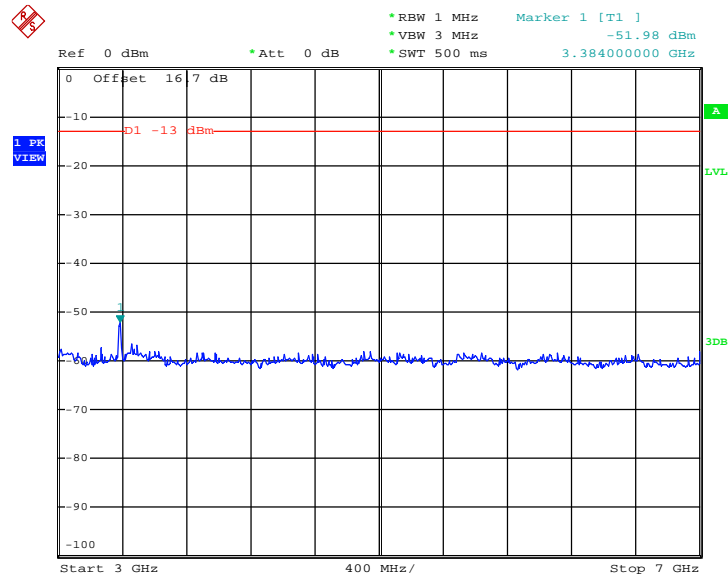

Date: 4.JUN.2015 13:47:49

Conducted Spurious Emission Plot between 7GHz ~ 9GHz

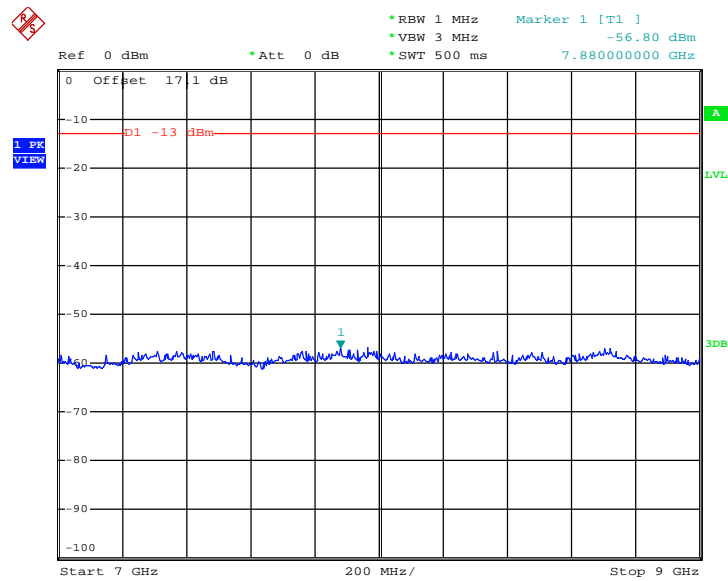

Date: 4.JUN.2015 13:48:40



Band :	WCDMA Band IV	Channel :	CH1312
Test Mode :	RMC 12.2Kbps Link (QPSK)	Frequency :	1712.4 MHz

Conducted Spurious Emission Plot between 30MHz ~ 1GHz

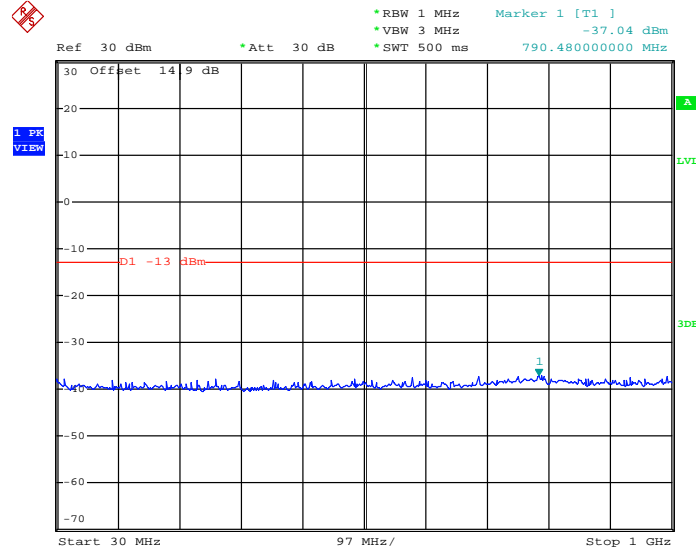

Conducted Spurious Emission Plot between 1GHz ~ 3GHz

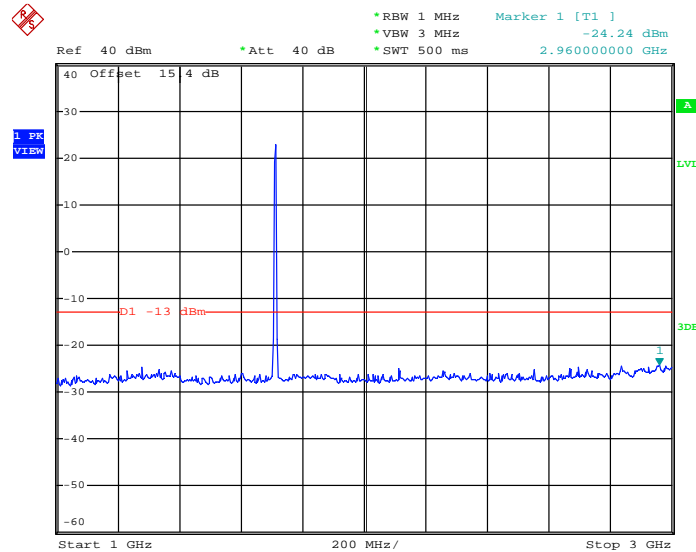



Conducted Spurious Emission Plot between 3GHz ~ 7GHz

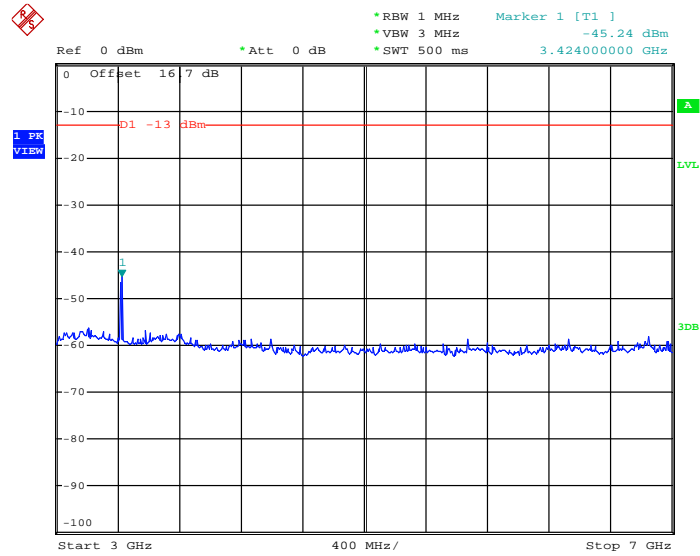

Date: 15.APR.2015 02:22:52

Conducted Spurious Emission Plot between 7GHz ~ 13.6GHz

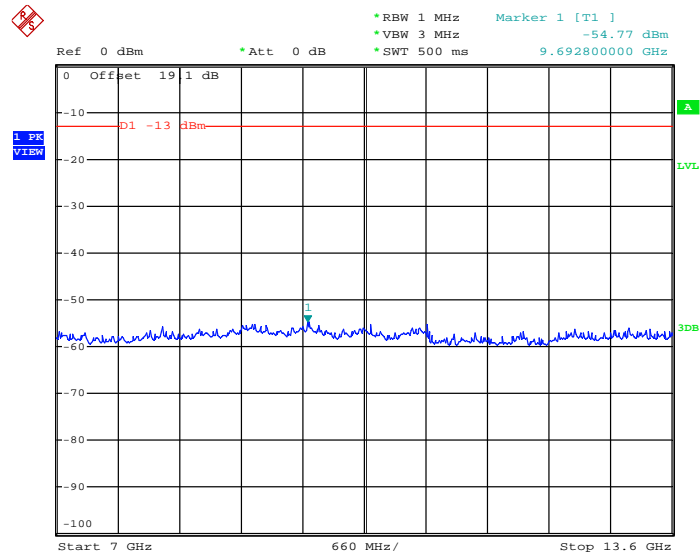

Date: 15.APR.2015 02:24:22



Conducted Spurious Emission Plot between 13.6GHz ~ 18GHz

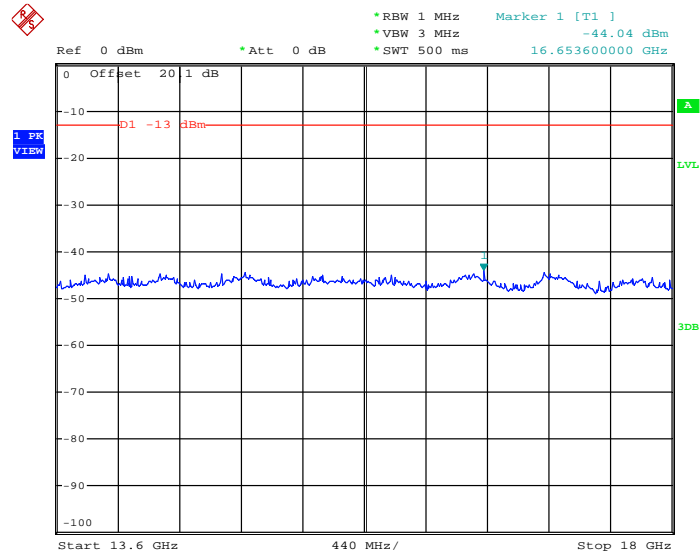

Date: 15.APR.2015 02:25:07



Band :	WCDMA Band IV	Channel :	CH1413
Test Mode :	RMC 12.2Kbps Link (QPSK)	Frequency :	1732.6 MHz

Conducted Spurious Emission Plot between 30MHz ~ 1GHz

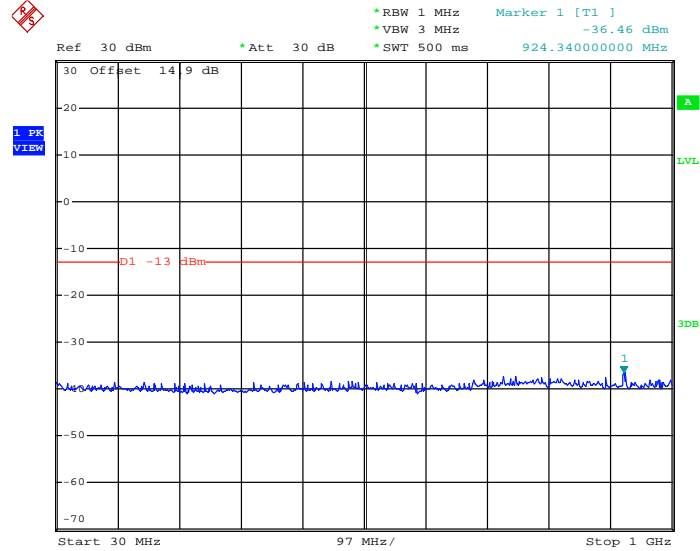

Date: 2.APR.2015 00:20:04

Conducted Spurious Emission Plot between 1GHz ~ 3GHz

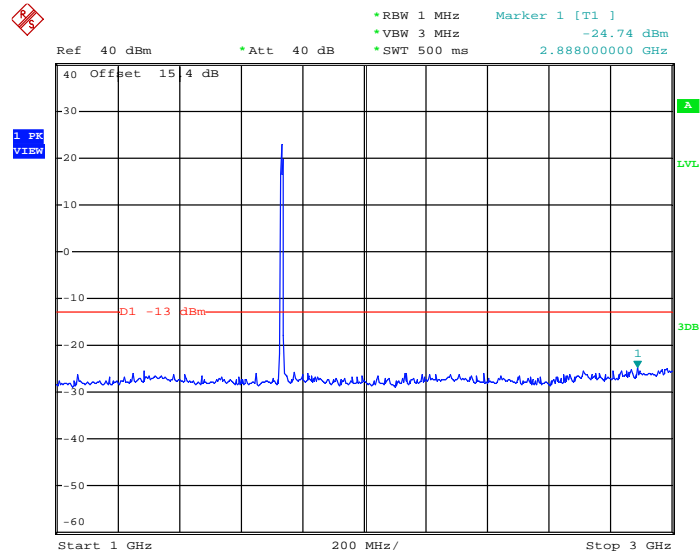

Date: 2.APR.2015 00:19:28



Conducted Spurious Emission Plot between 3GHz ~ 7GHz

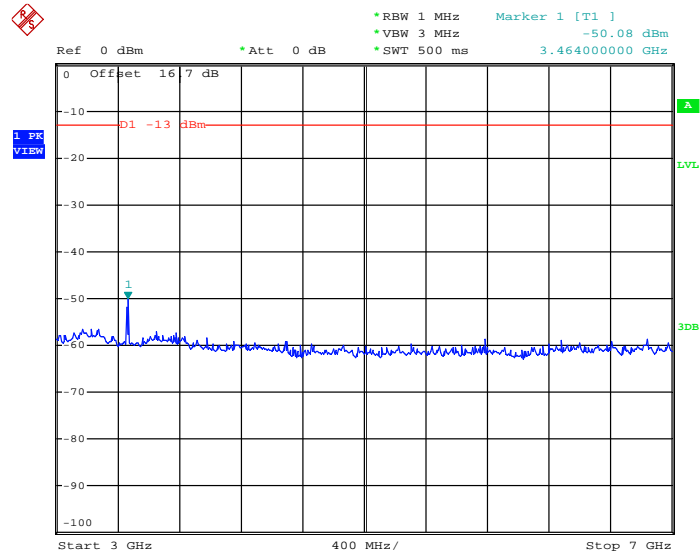

Date: 2.APR.2015 00:18:32

Conducted Spurious Emission Plot between 7GHz ~ 13.6GHz

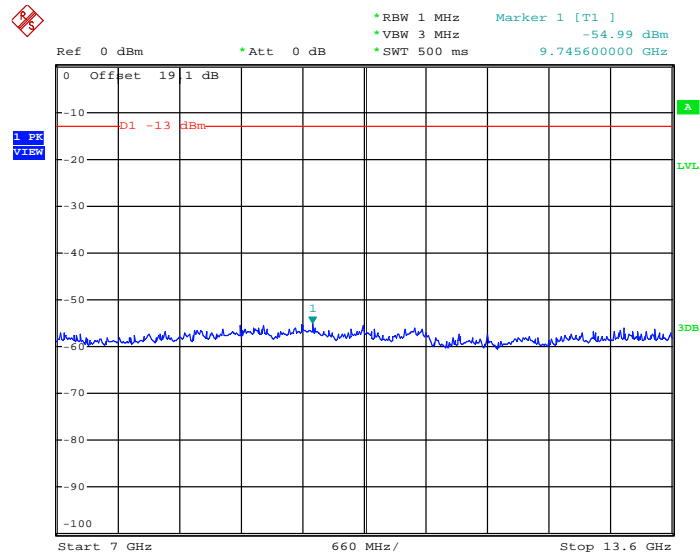

Date: 2.APR.2015 00:17:59



Conducted Spurious Emission Plot between 13.6GHz ~ 18GHz

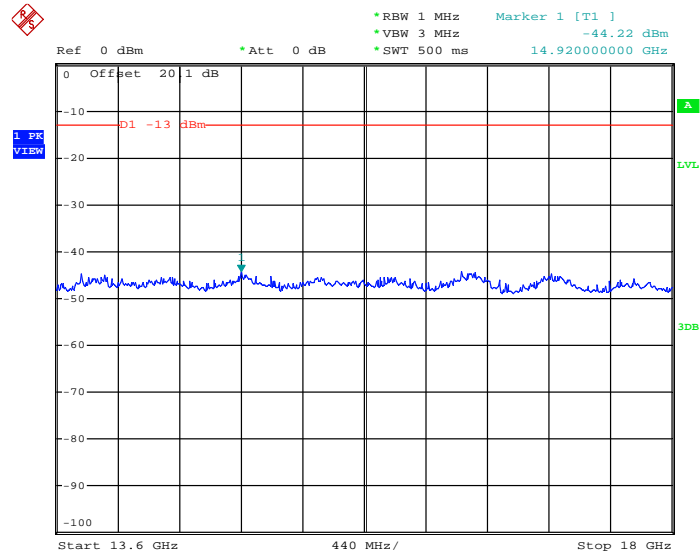

Date: 2.APR.2015 00:17:10



Band :	WCDMA Band IV	Channel :	CH1513
Test Mode :	RMC 12.2Kbps Link (QPSK)	Frequency :	1752.6 MHz

Conducted Spurious Emission Plot between 30MHz ~ 1GHz

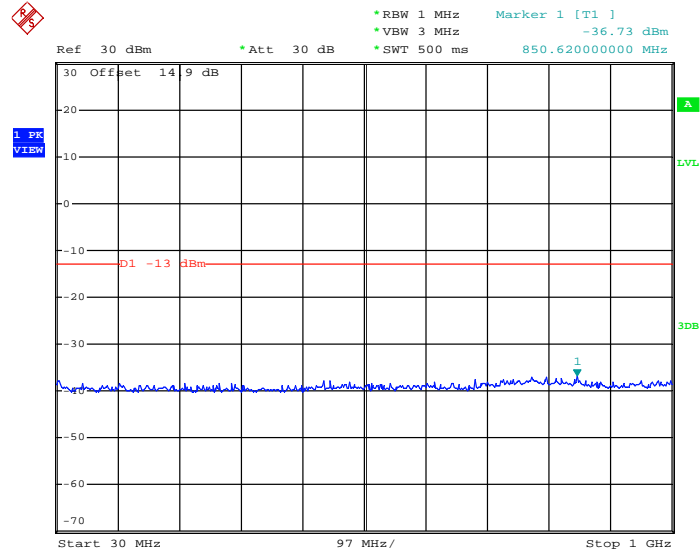

Date: 15.APR.2015 02:18:33

Conducted Spurious Emission Plot between 1GHz ~ 3GHz

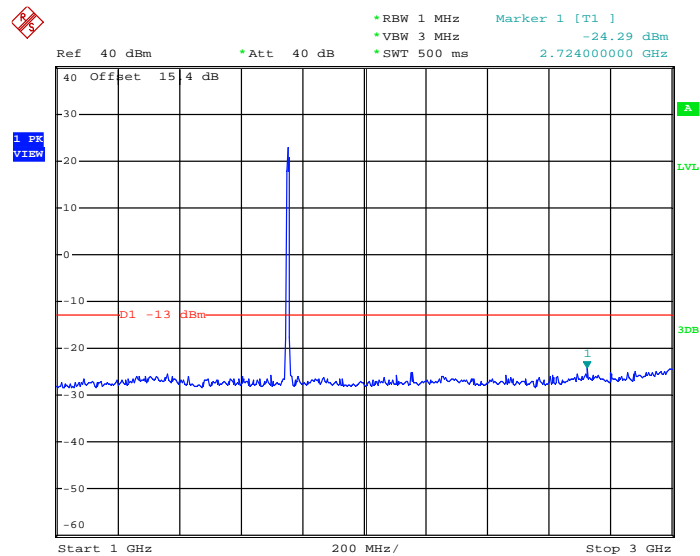

Date: 15.APR.2015 02:21:06



Conducted Spurious Emission Plot between 3GHz ~ 7GHz

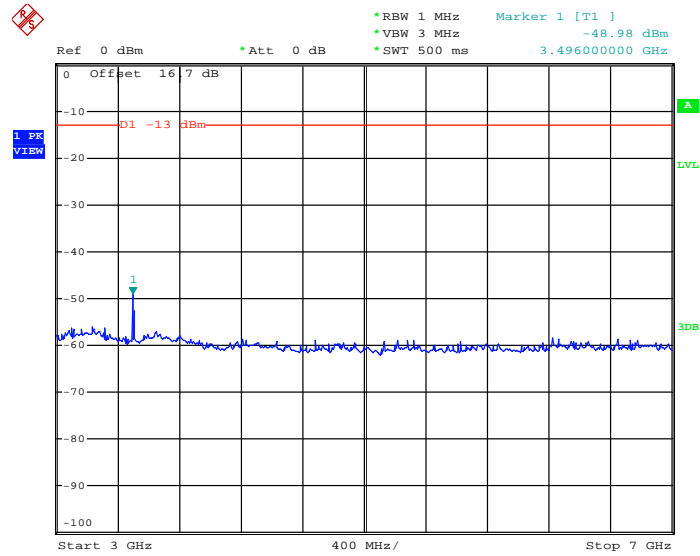

Date: 15.APR.2015 02:23:20

Conducted Spurious Emission Plot between 7GHz ~ 13.6GHz

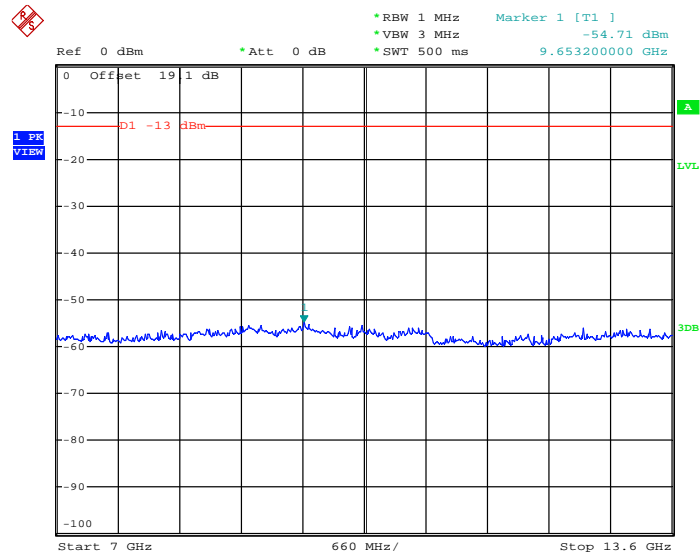

Date: 15.APR.2015 02:24:03



Conducted Spurious Emission Plot between 13.6GHz ~ 18GHz

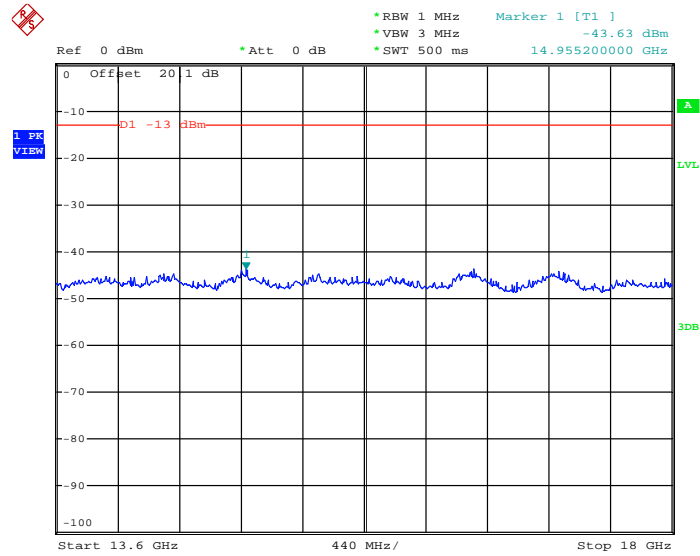

Date: 15.APR.2015 02:25:27



Band :	WCDMA Band II	Channel :	CH9262
Test Mode :	RMC 12.2Kbps Link (QPSK)	Frequency :	1852.4 MHz

Conducted Spurious Emission Plot between 30MHz ~ 1GHz

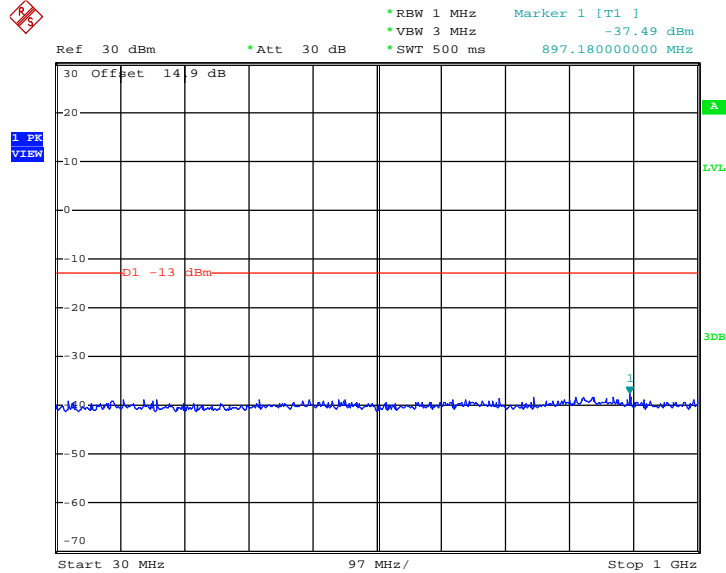

Date: 4.JUN.2015 13:53:49

Conducted Spurious Emission Plot between 1GHz ~ 3GHz

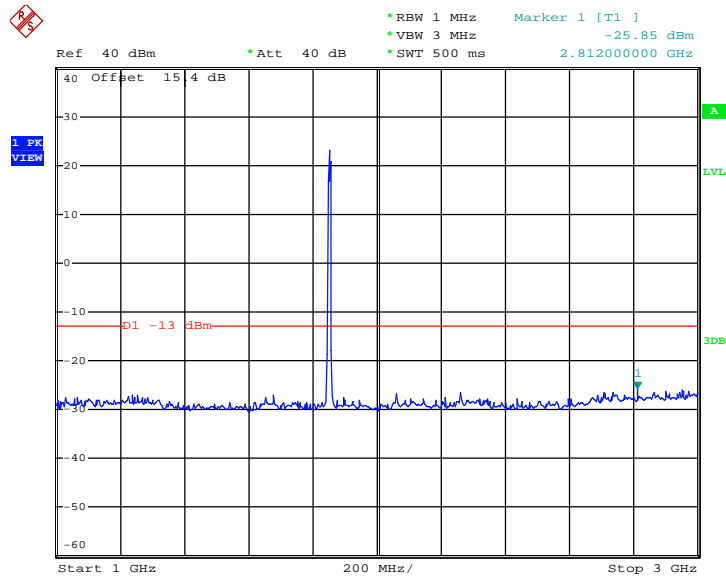

Date: 4.JUN.2015 13:57:09



Conducted Spurious Emission Plot between 3GHz ~ 7GHz

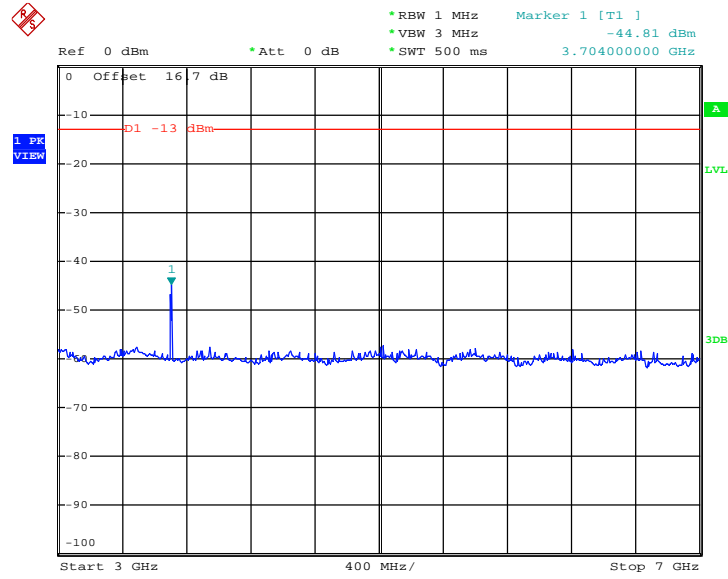

Date: 4.JUN.2015 14:00:19

Conducted Spurious Emission Plot between 7GHz ~ 13.6GHz

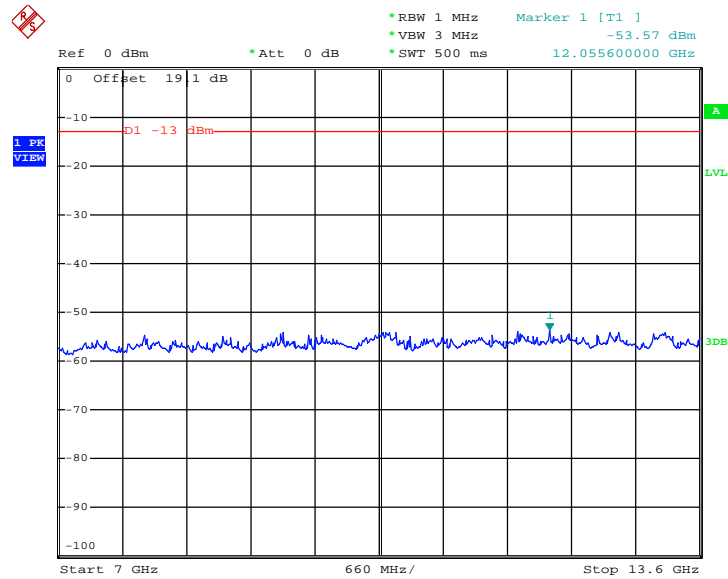

Date: 4.JUN.2015 14:01:56



Conducted Spurious Emission Plot between 13.6GHz ~ 19.1GHz

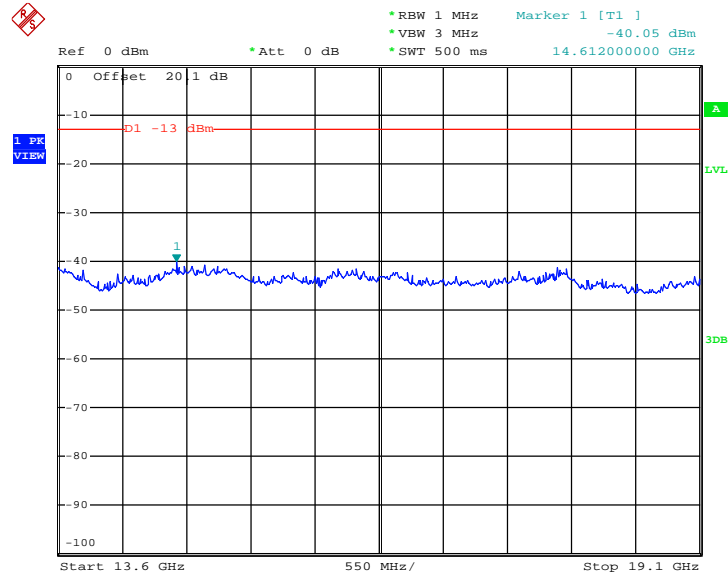

Date: 4.JUN.2015 14:04:15



Band :	WCDMA Band II	Channel :	CH9400
Test Mode :	RMC 12.2Kbps Link (QPSK)	Frequency :	1880.0 MHz

Conducted Spurious Emission Plot between 30MHz ~ 1GHz

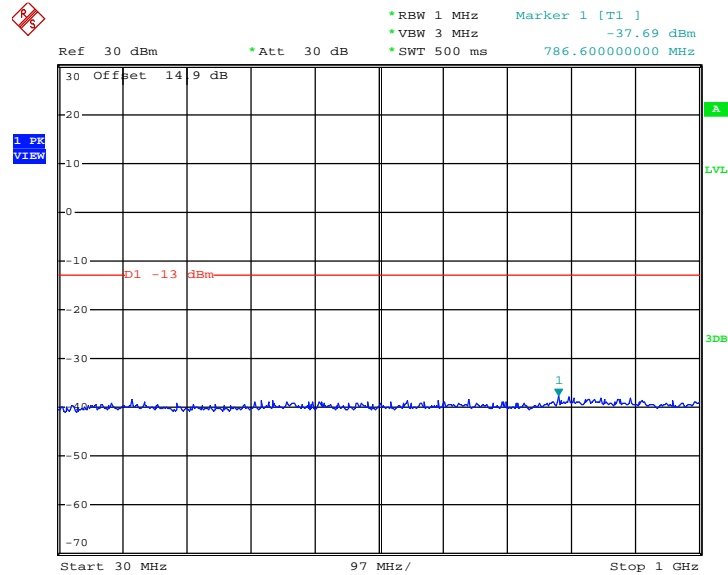

Conducted Spurious Emission Plot between 1GHz ~ 3GHz

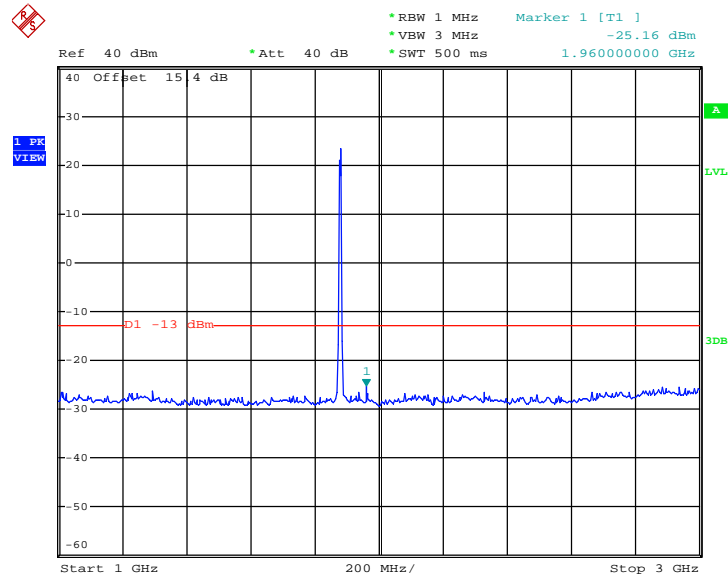



Conducted Spurious Emission Plot between 3GHz ~ 7GHz

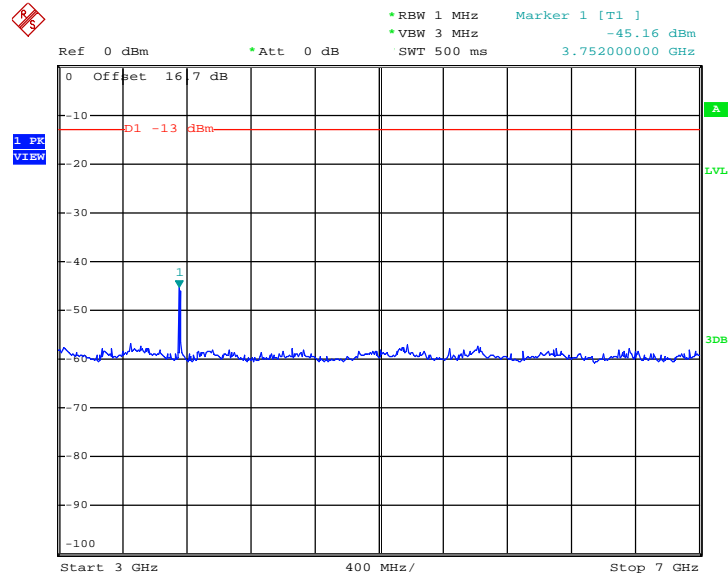

Conducted Spurious Emission Plot between 7GHz ~ 13.6GHz

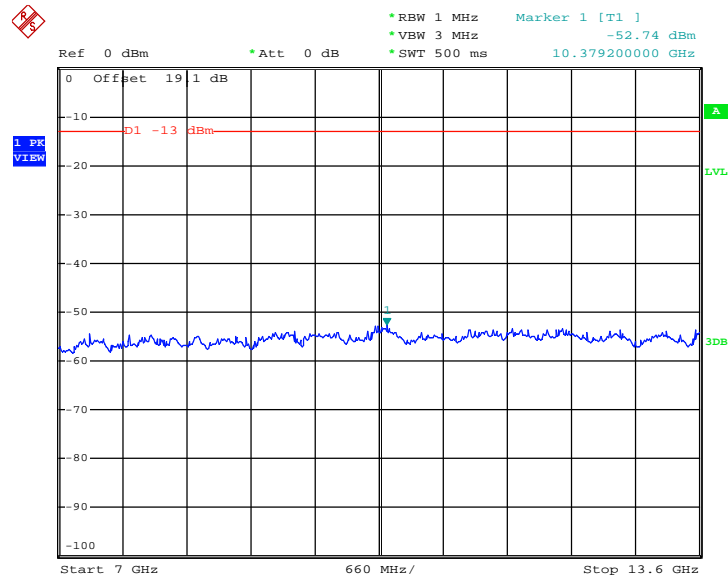



Conducted Spurious Emission Plot between 13.6GHz ~ 19.1GHz

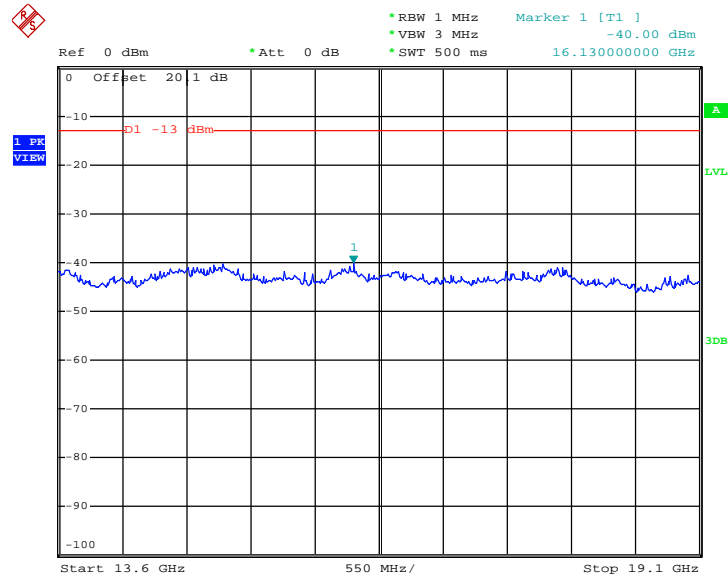



Band :	WCDMA Band II	Channel :	CH9538
Test Mode :	RMC 12.2Kbps Link (QPSK)	Frequency :	1907.6 MHz

Conducted Spurious Emission Plot between 30MHz ~ 1GHz

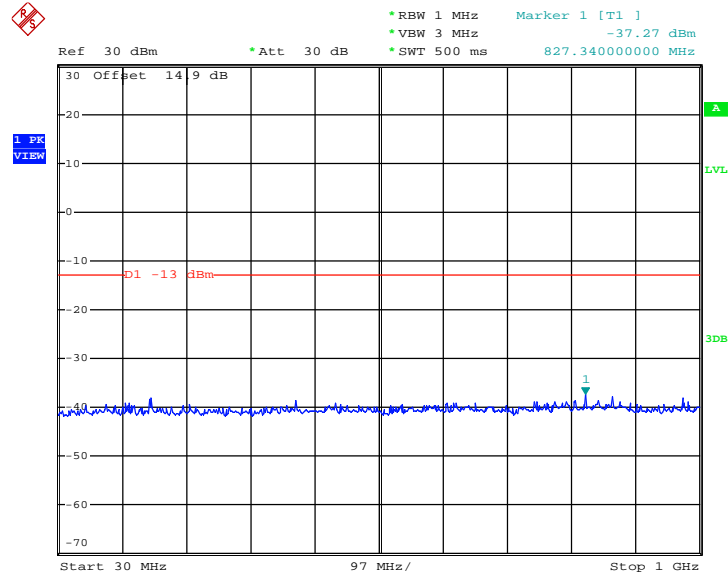

Date: 4.JUN.2015 13:52:59

Conducted Spurious Emission Plot between 1GHz ~ 3GHz

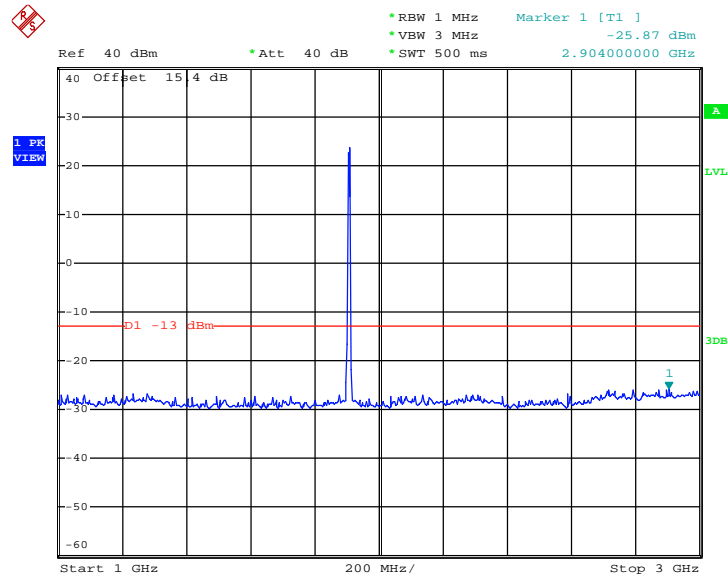

Date: 4.JUN.2015 13:58:02



Conducted Spurious Emission Plot between 3GHz ~ 7GHz

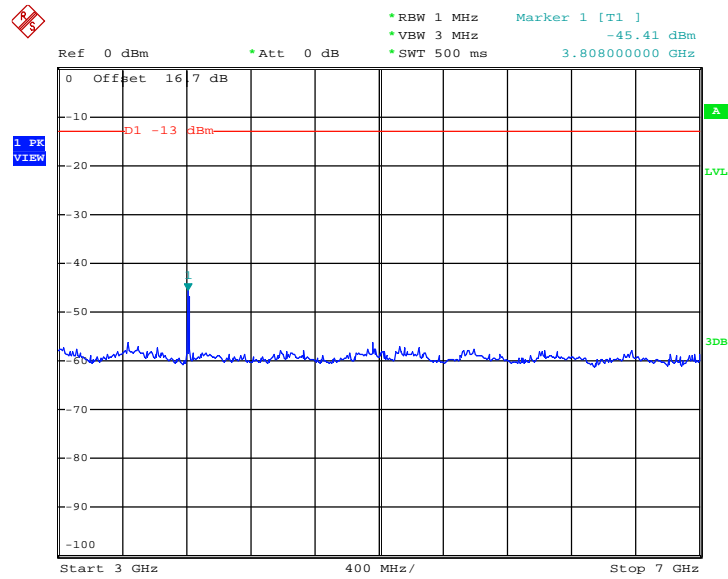

Date: 4.JUN.2015 13:59:47

Conducted Spurious Emission Plot between 7GHz ~ 13.6GHz

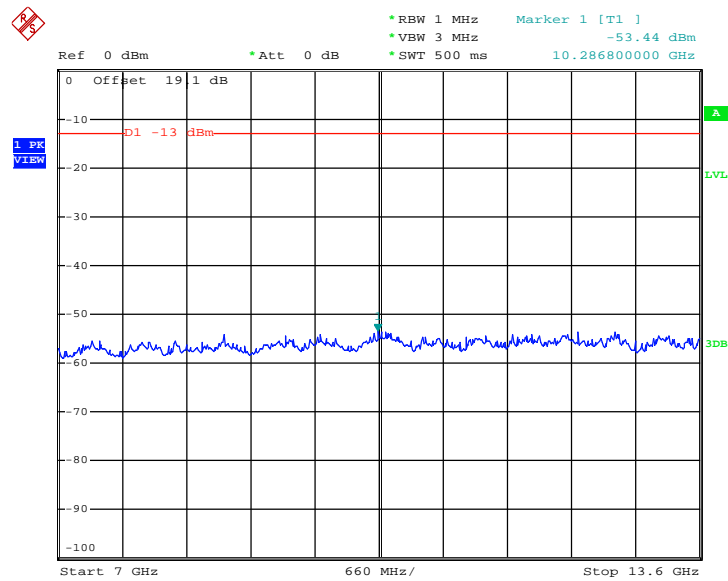

Date: 4.JUN.2015 14:02:57



Conducted Spurious Emission Plot between 13.6GHz ~ 19.1GHz

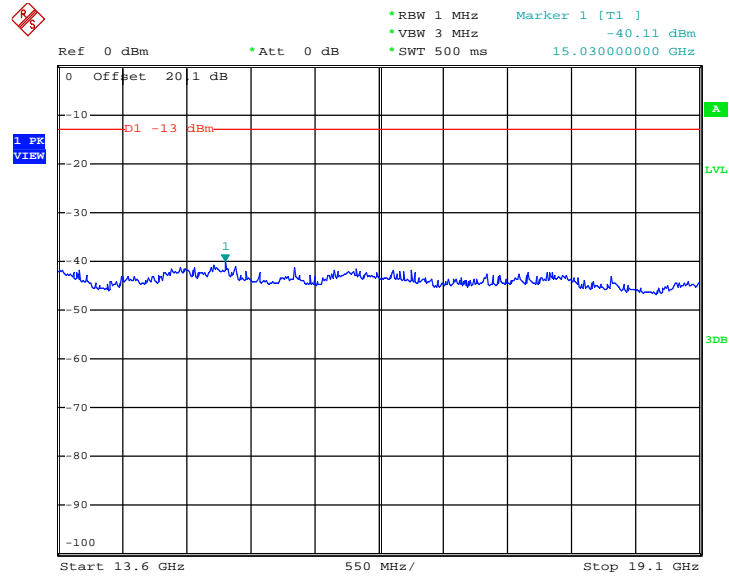

Date: 4.JUN.2015 14:03:47



3.7 Field Strength of Spurious Radiation Measurement

3.7.1 Description of Field Strength of Spurious Radiated Measurement

The power of any emission outside of the authorized operating frequency ranges must be attenuated below the transmitter power (P) by a factor of at least $43 + 10 \log (P)$ dB. The spectrum is scanned from 30 MHz up to a frequency including its 10th harmonic.

3.7.2 Measuring Instruments

The measuring equipment is listed in the section 4 of this test report.

3.7.3 Test Procedures

1. The testing follows FCC KDB 971168 v02r02 Section 5.8 and ANSI / TIA-603-C-2004 Section 2.2.12.
2. The EUT was placed on a rotatable wooden table 0.8 meters above the ground.
3. The EUT was set 3 meters from the receiving antenna, which was mounted on the antenna tower.
4. The table was rotated 360 degrees to determine the position of the highest spurious emission.
5. The height of the receiving antenna is varied between one meter and four meters to search for the maximum spurious emission for both horizontal and vertical polarizations.
6. Make the measurement with the spectrum analyzer's RBW = 1MHz, VBW = 3MHz, taking record of maximum spurious emission.
7. A horn antenna was substituted in place of the EUT and was driven by a signal generator.
8. Tune the output power of signal generator to the same emission level with EUT maximum spurious emission.
9. Taking the record of output power at antenna port.
10. Repeat step 7 to step 8 for another polarization.
11. $EIRP \text{ (dBm)} = S.G. \text{ Power} - Tx \text{ Cable Loss} + Tx \text{ Antenna Gain}$
12. $ERP \text{ (dBm)} = EIRP - 2.15$
13. The RF fundamental frequency should be excluded against the limit line in the operating frequency band.
14. The limit line is derived from $43 + 10\log(P)$ dB below the transmitter power P(Watts)
 $= P(W) - [43 + 10\log(P)] \text{ (dB)}$
 $= [30 + 10\log(P)] \text{ (dBm)} - [43 + 10\log(P)] \text{ (dB)}$
 $= -13\text{dBm}.$

3.7.4 Test Setup

For radiated emissions from 30MHz to 1GHz

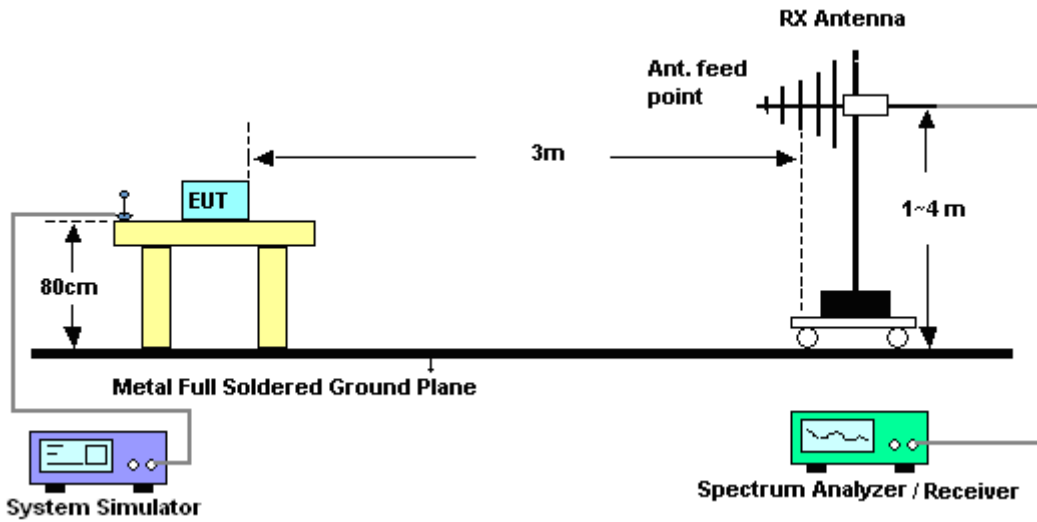

For radiated emissions above 1GHz

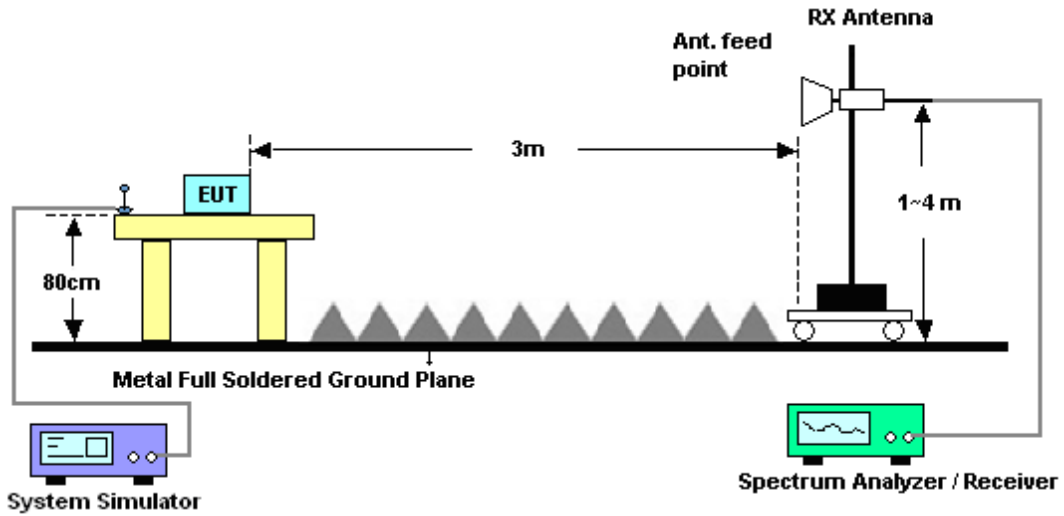



3.7.5 Test Result of Field Strength of Spurious Radiated

Band :	GSM850 for CH128					Temperature :	23~25°C		
Test Mode :	GSM Link (GMSK)					Relative Humidity :	42~58%		
Test Engineer :	Lewis He					Polarization :	Horizontal		
Remark :	Spurious emissions within 30-1000MHz were found more than 20dB below limit line.								
Frequency (MHz)	ERP (dBm)	Limit (dBm)	Over Limit (dB)	SPA Reading (dBm)	S.G. Power (dBm)	TX Cable loss (dB)	TX Antenna Gain (dBi)	Polarization (H/V)	Result
1648	-51.39	-13	-38.39	-53.79	-53.28	1.86	5.90	H	Pass
2474	-54.10	-13	-41.10	-63.13	-56.44	2.31	6.80	H	Pass
3296	-53.59	-13	-40.59	-66.22	-55.99	2.85	7.40	H	Pass

Band :	GSM850 for CH128					Temperature :	23~25°C		
Test Mode :	GSM Link (GMSK)					Relative Humidity :	42~58%		
Test Engineer :	Lewis He					Polarization :	Vertical		
Remark :	Spurious emissions within 30-1000MHz were found more than 20dB below limit line.								
Frequency (MHz)	ERP (dBm)	Limit (dBm)	Over Limit (dB)	SPA Reading (dBm)	S.G. Power (dBm)	TX Cable loss (dB)	TX Antenna Gain (dBi)	Polarization (H/V)	Result
1648	-47.34	-13	-34.34	-51.04	-49.23	1.86	5.90	V	Pass
2474	-51.96	-13	-38.96	-62.93	-54.30	2.31	6.80	V	Pass
3296	-51.87	-13	-38.87	-65.85	-54.27	2.85	7.40	V	Pass



Band :	GSM850 for CH189					Temperature :	23~25°C		
Test Mode :	GSM Link (GMSK)					Relative Humidity :	42~58%		
Test Engineer :	Lewis He					Polarization :	Horizontal		
Remark :	Spurious emissions within 30-1000MHz were found more than 20dB below limit line.								
Frequency (MHz)	ERP (dBm)	Limit (dBm)	Over Limit (dB)	SPA Reading (dBm)	S.G. Power (dBm)	TX Cable loss (dB)	TX Antenna Gain (dBi)	Polarization (H/V)	Result
1672	-50.31	-13	-37.31	-52.76	-52.20	1.86	5.90	H	Pass
2509	-53.98	-13	-40.98	-63.01	-56.32	2.31	6.80	H	Pass
3344	-53.00	-13	-40.00	-65.63	-55.40	2.85	7.40	H	Pass

Band :	GSM850 for CH189					Temperature :	23~25°C		
Test Mode :	GSM Link (GMSK)					Relative Humidity :	42~58%		
Test Engineer :	Lewis He					Polarization :	Vertical		
Remark :	Spurious emissions within 30-1000MHz were found more than 20dB below limit line.								
Frequency (MHz)	ERP (dBm)	Limit (dBm)	Over Limit (dB)	SPA Reading (dBm)	S.G. Power (dBm)	TX Cable loss (dB)	TX Antenna Gain (dBi)	Polarization (H/V)	Result
1672	-47.00	-13	-34.00	-50.80	-48.89	1.86	5.90	V	Pass
2509	-51.90	-13	-38.90	-62.87	-54.24	2.31	6.80	V	Pass
3344	-52.15	-13	-39.15	-66.13	-54.55	2.85	7.40	V	Pass



Band :	GSM850 for CH251					Temperature :	23~25°C		
Test Mode :	GSM Link (GMSK)					Relative Humidity :	42~58%		
Test Engineer :	Lewis He					Polarization :	Horizontal		
Remark :	Spurious emissions within 30-1000MHz were found more than 20dB below limit line.								
Frequency (MHz)	ERP (dBm)	Limit (dBm)	Over Limit (dB)	SPA Reading (dBm)	S.G. Power (dBm)	TX Cable loss (dB)	TX Antenna Gain (dBi)	Polarization (H/V)	Result
1698	-50.85	-13	-37.85	-53.37	-52.74	1.86	5.90	H	Pass
2548	-54.24	-13	-41.24	-63.27	-56.58	2.31	6.80	H	Pass
3396	-52.54	-13	-39.54	-65.17	-54.94	2.85	7.40	H	Pass

Band :	GSM850 for CH251					Temperature :	23~25°C		
Test Mode :	GSM Link (GMSK)					Relative Humidity :	42~58%		
Test Engineer :	Lewis He					Polarization :	Vertical		
Remark :	Spurious emissions within 30-1000MHz were found more than 20dB below limit line.								
Frequency (MHz)	ERP (dBm)	Limit (dBm)	Over Limit (dB)	SPA Reading (dBm)	S.G. Power (dBm)	TX Cable loss (dB)	TX Antenna Gain (dBi)	Polarization (H/V)	Result
1698	-47.50	-13	-34.50	-51.15	-49.39	1.86	5.90	V	Pass
2548	-49.47	-13	-36.47	-60.44	-51.81	2.31	6.80	V	Pass
3396	-51.80	-13	-38.80	-65.78	-54.20	2.85	7.40	V	Pass



Band :	GSM850 for CH128					Temperature :	23~25°C		
Test Mode :	EDGE class 8 Link (8PSK)					Relative Humidity :	42~58%		
Test Engineer :	Lewis He					Polarization :	Horizontal		
Remark :	Spurious emissions within 30-1000MHz were found more than 20dB below limit line.								
Frequency (MHz)	ERP (dBm)	Limit (dBm)	Over Limit (dB)	SPA Reading (dBm)	S.G. Power (dBm)	TX Cable loss (dB)	TX Antenna Gain (dBi)	Polarization (H/V)	Result
1648	-53.65	-13	-40.65	-55.83	-55.54	1.86	5.90	H	Pass
2474	-53.75	-13	-40.75	-62.78	-56.09	2.31	6.80	H	Pass
3296	-53.02	-13	-40.02	-65.65	-55.42	2.85	7.40	H	Pass

Band :	GSM850 for CH128					Temperature :	23~25°C		
Test Mode :	EDGE class 8 Link (8PSK)					Relative Humidity :	42~58%		
Test Engineer :	Lewis He					Polarization :	Vertical		
Remark :	Spurious emissions within 30-1000MHz were found more than 20dB below limit line.								
Frequency (MHz)	ERP (dBm)	Limit (dBm)	Over Limit (dB)	SPA Reading (dBm)	S.G. Power (dBm)	TX Cable loss (dB)	TX Antenna Gain (dBi)	Polarization (H/V)	Result
1648	-53.25	-13	-40.25	-53.83	-55.14	1.86	5.90	V	Pass
2474	-51.82	-13	-38.82	-62.79	-54.16	2.31	6.80	V	Pass
3296	-51.57	-13	-38.57	-65.55	-53.97	2.85	7.40	V	Pass



Band :	GSM850 for CH189					Temperature :	23~25°C		
Test Mode :	EDGE class 8 Link (8PSK)					Relative Humidity :	42~58%		
Test Engineer :	Lewis He					Polarization :	Horizontal		
Remark :	Spurious emissions within 30-1000MHz were found more than 20dB below limit line.								
Frequency (MHz)	ERP (dBm)	Limit (dBm)	Over Limit (dB)	SPA Reading (dBm)	S.G. Power (dBm)	TX Cable loss (dB)	TX Antenna Gain (dBi)	Polarization (H/V)	Result
1672	-52.61	-13	-39.61	-54.79	-54.50	1.86	5.90	H	Pass
2509	-54.31	-13	-41.31	-63.34	-56.65	2.31	6.80	H	Pass
3344	-52.51	-13	-39.51	-65.14	-54.91	2.85	7.40	H	Pass

Band :	GSM850 for CH189					Temperature :	23~25°C		
Test Mode :	EDGE class 8 Link (8PSK)					Relative Humidity :	42~58%		
Test Engineer :	Lewis He					Polarization :	Vertical		
Remark :	Spurious emissions within 30-1000MHz were found more than 20dB below limit line.								
Frequency (MHz)	ERP (dBm)	Limit (dBm)	Over Limit (dB)	SPA Reading (dBm)	S.G. Power (dBm)	TX Cable loss (dB)	TX Antenna Gain (dBi)	Polarization (H/V)	Result
1672	-52.74	-13	-39.74	-53.39	-54.63	1.86	5.90	V	Pass
2509	-52.23	-13	-39.23	-63.20	-54.57	2.31	6.80	V	Pass
3344	-50.92	-13	-37.92	-64.90	-53.32	2.85	7.40	V	Pass



Band :	GSM850 for CH251					Temperature :	23~25°C		
Test Mode :	EDGE class 8 Link (8PSK)					Relative Humidity :	42~58%		
Test Engineer :	Lewis He					Polarization :	Horizontal		
Remark :	Spurious emissions within 30-1000MHz were found more than 20dB below limit line.								
Frequency (MHz)	ERP (dBm)	Limit (dBm)	Over Limit (dB)	SPA Reading (dBm)	S.G. Power (dBm)	TX Cable loss (dB)	TX Antenna Gain (dBi)	Polarization (H/V)	Result
1698	-51.95	-13	-38.95	-54.15	-53.84	1.86	5.90	H	Pass
2548	-54.34	-13	-41.34	-63.37	-56.68	2.31	6.80	H	Pass
3396	-53.52	-13	-40.52	-66.15	-55.92	2.85	7.40	H	Pass

Band :	GSM850 for CH251					Temperature :	23~25°C		
Test Mode :	EDGE class 8 Link (8PSK)					Relative Humidity :	42~58%		
Test Engineer :	Lewis He					Polarization :	Vertical		
Remark :	Spurious emissions within 30-1000MHz were found more than 20dB below limit line.								
Frequency (MHz)	ERP (dBm)	Limit (dBm)	Over Limit (dB)	SPA Reading (dBm)	S.G. Power (dBm)	TX Cable loss (dB)	TX Antenna Gain (dBi)	Polarization (H/V)	Result
1698	-53.53	-13	-40.53	-54.16	-55.42	1.86	5.90	V	Pass
2548	-51.46	-13	-38.46	-62.43	-53.80	2.31	6.80	V	Pass
3396	-51.35	-13	-38.35	-65.33	-53.75	2.85	7.40	V	Pass



Band :	GSM1900 for CH512					Temperature :	23~25°C		
Test Mode :	GSM Link (GMSK)					Relative Humidity :	42~58%		
Test Engineer :	Lewis He					Polarization :	Horizontal		
Remark :	Spurious emissions within 30-1000MHz were found more than 20dB below limit line.								
Frequency (MHz)	EIRP (dBm)	Limit (dBm)	Over Limit (dB)	SPA Reading (dBm)	S.G. Power (dBm)	TX Cable loss (dB)	TX Antenna Gain (dBi)	Polarization (H/V)	Result
3699	-50.07	-13	-37.07	-64.27	-54.67	3	7.60	H	Pass
5551	-47.73	-13	-34.73	-61.52	-53.99	3.84	10.10	H	Pass
7401	-42.35	-13	-29.35	-62.13	-49.85	4.43	11.93	H	Pass

Band :	GSM1900 for CH512					Temperature :	23~25°C		
Test Mode :	GSM Link (GMSK)					Relative Humidity :	42~58%		
Test Engineer :	Lewis He					Polarization :	Vertical		
Remark :	Spurious emissions within 30-1000MHz were found more than 20dB below limit line.								
Frequency (MHz)	EIRP (dBm)	Limit (dBm)	Over Limit (dB)	SPA Reading (dBm)	S.G. Power (dBm)	TX Cable loss (dB)	TX Antenna Gain (dBi)	Polarization (H/V)	Result
3700	-52.96	-13	-39.96	-65.45	-57.56	3	7.60	V	Pass
5550	-48.83	-13	-35.83	-61.24	-55.09	3.84	10.10	V	Pass
7401	-42.82	-13	-29.82	-60.61	-50.32	4.43	11.93	V	Pass



Band :	GSM1900 for CH661					Temperature :	23~25°C		
Test Mode :	GSM Link (GMSK)					Relative Humidity :	42~58%		
Test Engineer :	Lewis He					Polarization :	Horizontal		
Remark :	Spurious emissions within 30-1000MHz were found more than 20dB below limit line.								
Frequency (MHz)	EIRP (dBm)	Limit (dBm)	Over Limit (dB)	SPA Reading (dBm)	S.G. Power (dBm)	TX Cable loss (dB)	TX Antenna Gain (dBi)	Polarization (H/V)	Result
3759	-50.81	-13	-37.81	-65.01	-55.41	3	7.60	H	Pass
5640	-46.03	-13	-33.03	-59.82	-52.29	3.84	10.10	H	Pass
7521	-44.25	-13	-31.25	-64.03	-51.75	4.43	11.93	H	Pass

Band :	GSM1900 for CH661					Temperature :	23~25°C		
Test Mode :	GSM Link (GMSK)					Relative Humidity :	42~58%		
Test Engineer :	Lewis He					Polarization :	Vertical		
Remark :	Spurious emissions within 30-1000MHz were found more than 20dB below limit line.								
Frequency (MHz)	EIRP (dBm)	Limit (dBm)	Over Limit (dB)	SPA Reading (dBm)	S.G. Power (dBm)	TX Cable loss (dB)	TX Antenna Gain (dBi)	Polarization (H/V)	Result
3759	-53.33	-13	-40.33	-65.82	-57.93	3	7.60	V	Pass
5640	-48.97	-13	-35.97	-61.38	-55.23	3.84	10.10	V	Pass
7521	-45.41	-13	-32.41	-63.2	-52.91	4.43	11.93	V	Pass



Band :	GSM1900 for CH810					Temperature :	23~25°C		
Test Mode :	GSM Link (GMSK)					Relative Humidity :	42~58%		
Test Engineer :	Lewis He					Polarization :	Horizontal		
Remark :	Spurious emissions within 30-1000MHz were found more than 20dB below limit line.								
Frequency (MHz)	EIRP (dBm)	Limit (dBm)	Over Limit (dB)	SPA Reading (dBm)	S.G. Power (dBm)	TX Cable loss (dB)	TX Antenna Gain (dBi)	Polarization (H/V)	Result
3820	-50.97	-13	-37.97	-65.17	-55.57	3	7.60	H	Pass
5730	-47.25	-13	-34.25	-61.04	-53.51	3.84	10.10	H	Pass
7638	-43.18	-13	-30.18	-62.96	-50.68	4.43	11.93	H	Pass

Band :	GSM1900 for CH810					Temperature :	23~25°C		
Test Mode :	GSM Link (GMSK)					Relative Humidity :	42~58%		
Test Engineer :	Lewis He					Polarization :	Vertical		
Remark :	Spurious emissions within 30-1000MHz were found more than 20dB below limit line.								
Frequency (MHz)	EIRP (dBm)	Limit (dBm)	Over Limit (dB)	SPA Reading (dBm)	S.G. Power (dBm)	TX Cable loss (dB)	TX Antenna Gain (dBi)	Polarization (H/V)	Result
3819	-53.99	-13	-40.99	-66.48	-58.59	3	7.60	V	Pass
5729	-48.20	-13	-35.20	-60.61	-54.46	3.84	10.10	V	Pass
7638	-45.69	-13	-32.69	-63.48	-53.19	4.43	11.93	V	Pass



Band :	GSM1900 for CH512					Temperature :	23~25°C		
Test Mode :	EDGE class 8 Link (8PSK)					Relative Humidity :	42~58%		
Test Engineer :	Lewis He					Polarization :	Horizontal		
Remark :	Spurious emissions within 30-1000MHz were found more than 20dB below limit line.								
Frequency (MHz)	EIRP (dBm)	Limit (dBm)	Over Limit (dB)	SPA Reading (dBm)	S.G. Power (dBm)	TX Cable loss (dB)	TX Antenna Gain (dBi)	Polarization (H/V)	Result
3699	-51.44	-13	-38.44	-65.64	-56.04	3	7.60	H	Pass
5551	-47.81	-13	-34.81	-61.60	-54.07	3.84	10.10	H	Pass
7401	-41.94	-13	-28.94	-61.72	-49.44	4.43	11.93	H	Pass

Band :	GSM1900 for CH512					Temperature :	23~25°C		
Test Mode :	EDGE class 8 Link (8PSK)					Relative Humidity :	42~58%		
Test Engineer :	Lewis He					Polarization :	Vertical		
Remark :	Spurious emissions within 30-1000MHz were found more than 20dB below limit line.								
Frequency (MHz)	EIRP (dBm)	Limit (dBm)	Over Limit (dB)	SPA Reading (dBm)	S.G. Power (dBm)	TX Cable loss (dB)	TX Antenna Gain (dBi)	Polarization (H/V)	Result
3699	-52.81	-13	-39.81	-65.3	-57.41	3	7.60	V	Pass
5551	-50.00	-13	-37.00	-62.41	-56.26	3.84	10.10	V	Pass
7401	-45.00	-13	-32.00	-62.79	-52.50	4.43	11.93	V	Pass



Band :	GSM1900 for CH661					Temperature :	23~25°C		
Test Mode :	EDGE class 8 Link (8PSK)					Relative Humidity :	42~58%		
Test Engineer :	Lewis He					Polarization :	Horizontal		
Remark :	Spurious emissions within 30-1000MHz were found more than 20dB below limit line.								
Frequency (MHz)	EIRP (dBm)	Limit (dBm)	Over Limit (dB)	SPA Reading (dBm)	S.G. Power (dBm)	TX Cable loss (dB)	TX Antenna Gain (dBi)	Polarization (H/V)	Result
3759	-51.91	-13	-38.91	-66.11	-56.51	3	7.60	H	Pass
5640	-47.31	-13	-34.31	-61.10	-53.57	3.84	10.10	H	Pass
7521	-44.00	-13	-31.00	-63.78	-51.50	4.43	11.93	H	Pass

Band :	GSM1900 for CH661					Temperature :	23~25°C		
Test Mode :	EDGE class 8 Link (8PSK)					Relative Humidity :	42~58%		
Test Engineer :	Lewis He					Polarization :	Vertical		
Remark :	Spurious emissions within 30-1000MHz were found more than 20dB below limit line.								
Frequency (MHz)	EIRP (dBm)	Limit (dBm)	Over Limit (dB)	SPA Reading (dBm)	S.G. Power (dBm)	TX Cable loss (dB)	TX Antenna Gain (dBi)	Polarization (H/V)	Result
3759	-53.34	-13	-40.34	-65.83	-57.94	3	7.60	V	Pass
5640	-49.29	-13	-36.29	-61.7	-55.55	3.84	10.10	V	Pass
7521	-45.46	-13	-32.46	-63.25	-52.96	4.43	11.93	V	Pass



Band :	GSM1900 for CH810					Temperature :	23~25°C		
Test Mode :	EDGE class 8 Link (8PSK)					Relative Humidity :	42~58%		
Test Engineer :	Lewis He					Polarization :	Horizontal		
Remark :	Spurious emissions within 30-1000MHz were found more than 20dB below limit line.								
Frequency (MHz)	EIRP (dBm)	Limit (dBm)	Over Limit (dB)	SPA Reading (dBm)	S.G. Power (dBm)	TX Cable loss (dB)	TX Antenna Gain (dBi)	Polarization (H/V)	Result
3819	-52.11	-13	-39.11	-66.31	-56.71	3	7.60	H	Pass
5729	-46.85	-13	-33.85	-60.64	-53.11	3.84	10.10	H	Pass
7638	-42.02	-13	-29.02	-61.80	-49.52	4.43	11.93	H	Pass

Band :	GSM1900 for CH810					Temperature :	23~25°C		
Test Mode :	EDGE class 8 Link (8PSK)					Relative Humidity :	42~58%		
Test Engineer :	Lewis He					Polarization :	Vertical		
Remark :	Spurious emissions within 30-1000MHz were found more than 20dB below limit line.								
Frequency (MHz)	EIRP (dBm)	Limit (dBm)	Over Limit (dB)	SPA Reading (dBm)	S.G. Power (dBm)	TX Cable loss (dB)	TX Antenna Gain (dBi)	Polarization (H/V)	Result
3819	-53.91	-13	-40.91	-66.4	-58.51	3	7.60	V	Pass
5729	-48.47	-13	-35.47	-60.88	-54.73	3.84	10.10	V	Pass
7638	-44.99	-13	-31.99	-62.78	-52.49	4.43	11.93	V	Pass



Band :	WCDMA Band V for CH4132					Temperature :	23~25°C		
Test Mode :	RMC 12.2Kbps Link (QPSK)					Relative Humidity :	42~58%		
Test Engineer :	Lewis He					Polarization :	Horizontal		
Remark :	Spurious emissions within 30-1000MHz were found more than 20dB below limit line.								
Frequency (MHz)	ERP (dBm)	Limit (dBm)	Over Limit (dB)	SPA Reading (dBm)	S.G. Power (dBm)	TX Cable loss (dB)	TX Antenna Gain (dBi)	Polarization (H/V)	Result
1652	-55.85	-13	-42.85	-58.03	-57.74	1.86	5.90	H	Pass
2480	-53.30	-13	-40.30	-62.33	-55.64	2.31	6.80	H	Pass
3306	-53.11	-13	-40.11	-65.74	-55.51	2.85	7.40	H	Pass

Band :	WCDMA Band V for CH4132					Temperature :	23~25°C		
Test Mode :	RMC 12.2Kbps Link (QPSK)					Relative Humidity :	42~58%		
Test Engineer :	Lewis He					Polarization :	Vertical		
Remark :	Spurious emissions within 30-1000MHz were found more than 20dB below limit line.								
Frequency (MHz)	ERP (dBm)	Limit (dBm)	Over Limit (dB)	SPA Reading (dBm)	S.G. Power (dBm)	TX Cable loss (dB)	TX Antenna Gain (dBi)	Polarization (H/V)	Result
1652	-58.89	-13	-45.89	-57.75	-60.78	1.86	5.90	V	Pass
2480	-51.18	-13	-38.18	-62.15	-53.52	2.31	6.80	V	Pass
3306	-51.07	-13	-38.07	-65.05	-53.47	2.85	7.40	V	Pass



Band :	WCDMA Band V for CH4182					Temperature :	23~25°C		
Test Mode :	RMC 12.2Kbps Link (QPSK)					Relative Humidity :	42~58%		
Test Engineer :	Lewis He					Polarization :	Horizontal		
Remark :	Spurious emissions within 30-1000MHz were found more than 20dB below limit line.								
Frequency (MHz)	ERP (dBm)	Limit (dBm)	Over Limit (dB)	SPA Reading (dBm)	S.G. Power (dBm)	TX Cable loss (dB)	TX Antenna Gain (dBi)	Polarization (H/V)	Result
1672	-56.19	-13	-43.19	-58.37	-58.08	1.86	5.90	H	Pass
2509	-53.99	-13	-40.99	-63.02	-56.33	2.31	6.80	H	Pass
3344	-52.77	-13	-39.77	-65.40	-55.17	2.85	7.40	H	Pass

Band :	WCDMA Band V for CH4182					Temperature :	23~25°C		
Test Mode :	RMC 12.2Kbps Link (QPSK)					Relative Humidity :	42~58%		
Test Engineer :	Lewis He					Polarization :	Vertical		
Remark :	Spurious emissions within 30-1000MHz were found more than 20dB below limit line.								
Frequency (MHz)	ERP (dBm)	Limit (dBm)	Over Limit (dB)	SPA Reading (dBm)	S.G. Power (dBm)	TX Cable loss (dB)	TX Antenna Gain (dBi)	Polarization (H/V)	Result
1672	-58.84	-13	-45.84	-57.70	-60.73	1.86	5.90	V	Pass
2509	-52.15	-13	-39.15	-63.12	-54.49	2.31	6.80	V	Pass
3344	-51.46	-13	-38.46	-65.44	-53.86	2.85	7.40	V	Pass



Band :	WCDMA Band V for CH4233					Temperature :	23~25°C		
Test Mode :	RMC 12.2Kbps Link (QPSK)					Relative Humidity :	42~58%		
Test Engineer :	Lewis He					Polarization :	Horizontal		
Remark :	Spurious emissions within 30-1000MHz were found more than 20dB below limit line.								
Frequency (MHz)	ERP (dBm)	Limit (dBm)	Over Limit (dB)	SPA Reading (dBm)	S.G. Power (dBm)	TX Cable loss (dB)	TX Antenna Gain (dBi)	Polarization (H/V)	Result
1692	-56.53	-13	-43.53	-58.71	-58.42	1.86	5.90	H	Pass
2539	-54.59	-13	-41.59	-63.62	-56.93	2.31	6.80	H	Pass
3386	-53.61	-13	-40.61	-66.24	-56.01	2.85	7.40	H	Pass

Band :	WCDMA Band V for CH4233					Temperature :	23~25°C		
Test Mode :	RMC 12.2Kbps Link (QPSK)					Relative Humidity :	42~58%		
Test Engineer :	Lewis He					Polarization :	Vertical		
Remark :	Spurious emissions within 30-1000MHz were found more than 20dB below limit line.								
Frequency (MHz)	ERP (dBm)	Limit (dBm)	Over Limit (dB)	SPA Reading (dBm)	S.G. Power (dBm)	TX Cable loss (dB)	TX Antenna Gain (dBi)	Polarization (H/V)	Result
1692	-59.09	-13	-46.09	-57.95	-60.98	1.86	5.90	V	Pass
2539	-52.16	-13	-39.16	-63.13	-54.50	2.31	6.80	V	Pass
3386	-51.23	-13	-38.23	-65.21	-53.63	2.85	7.40	V	Pass



Band :	WCDMA Band IV for CH1312	Temperature :	23~25°C						
Test Mode :	RMC 12.2Kbps Link (QPSK)	Relative Humidity :	42~58%						
Test Engineer :	Lewis He	Polarization :	Horizontal						
Remark :	Spurious emissions within 30-1000MHz were found more than 20dB below limit line.								
Frequency (MHz)	EIRP (dBm)	Limit (dBm)	Over Limit (dB)	SPA Reading (dBm)	S.G. Power (dBm)	TX Cable loss (dB)	TX Antenna Gain (dBi)	Polarization (H/V)	Result
3423	-50.31	-13	-37.31	-64.44	-54.68	3.12	7.49	H	Pass
5136	-49.63	-13	-36.63	-62.78	-55.43	3.65	9.45	H	Pass
6849	-45.47	-13	-32.47	-62.33	-52.67	4.15	11.35	H	Pass

Band :	WCDMA Band IV for CH1312	Temperature :	23~25°C						
Test Mode :	RMC 12.2Kbps Link (QPSK)	Relative Humidity :	42~58%						
Test Engineer :	Lewis He	Polarization :	Vertical						
Remark :	Spurious emissions within 30-1000MHz were found more than 20dB below limit line.								
Frequency (MHz)	EIRP (dBm)	Limit (dBm)	Over Limit (dB)	SPA Reading (dBm)	S.G. Power (dBm)	TX Cable loss (dB)	TX Antenna Gain (dBi)	Polarization (H/V)	Result
3423	-53.45	-13	-40.45	-66.27	-57.82	3.12	7.49	V	Pass
5136	-48.39	-13	-35.39	-62.4	-54.19	3.65	9.45	V	Pass
6849	-47.25	-13	-34.25	-62.5	-54.45	4.15	11.35	V	Pass



Band :	WCDMA Band IV for CH1413	Temperature :	23~25°C						
Test Mode :	RMC 12.2Kbps Link (QPSK)	Relative Humidity :	42~58%						
Test Engineer :	Lewis He	Polarization :	Horizontal						
Remark :	Spurious emissions within 30-1000MHz were found more than 20dB below limit line.								
Frequency (MHz)	EIRP (dBm)	Limit (dBm)	Over Limit (dB)	SPA Reading (dBm)	S.G. Power (dBm)	TX Cable loss (dB)	TX Antenna Gain (dBi)	Polarization (H/V)	Result
3465	-50.97	-13	-37.97	-65.10	-55.34	3.12	7.49	H	Pass
5196	-47.68	-13	-34.68	-60.83	-53.48	3.65	9.45	H	Pass
6933	-45.17	-13	-32.17	-62.03	-52.37	4.15	11.35	H	Pass

Band :	WCDMA Band IV for CH1413	Temperature :	23~25°C						
Test Mode :	RMC 12.2Kbps Link (QPSK)	Relative Humidity :	42~58%						
Test Engineer :	Lewis He	Polarization :	Vertical						
Remark :	Spurious emissions within 30-1000MHz were found more than 20dB below limit line.								
Frequency (MHz)	EIRP (dBm)	Limit (dBm)	Over Limit (dB)	SPA Reading (dBm)	S.G. Power (dBm)	TX Cable loss (dB)	TX Antenna Gain (dBi)	Polarization (H/V)	Result
3465	-52.01	-13	-39.01	-64.83	-56.38	3.12	7.49	V	Pass
5196	-48.27	-13	-35.27	-62.28	-54.07	3.65	9.45	V	Pass
6933	-47.13	-13	-34.13	-62.38	-54.33	4.15	11.35	V	Pass



Band :	WCDMA Band IV for CH1513					Temperature :	23~25°C		
Test Mode :	RMC 12.2Kbps Link (QPSK)					Relative Humidity :	42~58%		
Test Engineer :	Lewis He					Polarization :	Horizontal		
Remark :	Spurious emissions within 30-1000MHz were found more than 20dB below limit line.								
Frequency (MHz)	EIRP (dBm)	Limit (dBm)	Over Limit (dB)	SPA Reading (dBm)	S.G. Power (dBm)	TX Cable loss (dB)	TX Antenna Gain (dBi)	Polarization (H/V)	Result
3504	-51.77	-13	-38.77	-65.90	-56.14	3.12	7.49	H	Pass
5256	-49.18	-13	-36.18	-62.33	-54.98	3.65	9.45	H	Pass
7011	-44.93	-13	-31.93	-61.79	-52.13	4.15	11.35	H	Pass

Band :	WCDMA Band IV for CH1513					Temperature :	23~25°C		
Test Mode :	RMC 12.2Kbps Link (QPSK)					Relative Humidity :	42~58%		
Test Engineer :	Lewis He					Polarization :	Vertical		
Remark :	Spurious emissions within 30-1000MHz were found more than 20dB below limit line.								
Frequency (MHz)	EIRP (dBm)	Limit (dBm)	Over Limit (dB)	SPA Reading (dBm)	S.G. Power (dBm)	TX Cable loss (dB)	TX Antenna Gain (dBi)	Polarization (H/V)	Result
3504	-53.26	-13	-40.26	-66.08	-57.63	3.12	7.49	V	Pass
5256	-47.92	-13	-34.92	-61.93	-53.72	3.65	9.45	V	Pass
7011	-46.10	-13	-33.10	-61.35	-53.30	4.15	11.35	V	Pass



Band :	WCDMA Band II for CH9262	Temperature :	23~25°C						
Test Mode :	RMC 12.2Kbps Link (QPSK)	Relative Humidity :	42~58%						
Test Engineer :	Lewis He	Polarization :	Horizontal						
Remark :	Spurious emissions within 30-1000MHz were found more than 20dB below limit line.								
Frequency (MHz)	EIRP (dBm)	Limit (dBm)	Over Limit (dB)	SPA Reading (dBm)	S.G. Power (dBm)	TX Cable loss (dB)	TX Antenna Gain (dBi)	Polarization (H/V)	Result
3705	-52.43	-13	-39.43	-66.63	-57.03	3	7.60	H	Pass
5557	-48.00	-13	-35.00	-61.79	-54.26	3.84	10.10	H	Pass
7410	-42.11	-13	-29.11	-61.89	-49.61	4.43	11.93	H	Pass

Band :	WCDMA Band II for CH9262	Temperature :	23~25°C						
Test Mode :	RMC 12.2Kbps Link (QPSK)	Relative Humidity :	42~58%						
Test Engineer :	Lewis He	Polarization :	Vertical						
Remark :	Spurious emissions within 30-1000MHz were found more than 20dB below limit line.								
Frequency (MHz)	EIRP (dBm)	Limit (dBm)	Over Limit (dB)	SPA Reading (dBm)	S.G. Power (dBm)	TX Cable loss (dB)	TX Antenna Gain (dBi)	Polarization (H/V)	Result
3705	-53.96	-13	-40.96	-66.45	-58.56	3	7.60	V	Pass
5557	-49.23	-13	-36.23	-61.64	-55.49	3.84	10.10	V	Pass
7410	-43.67	-13	-30.67	-61.46	-51.17	4.43	11.93	V	Pass



Band :	WCDMA Band II for CH9400	Temperature :	23~25°C						
Test Mode :	RMC 12.2Kbps Link (QPSK)	Relative Humidity :	42~58%						
Test Engineer :	Lewis He	Polarization :	Horizontal						
Remark :	Spurious emissions within 30-1000MHz were found more than 20dB below limit line.								
Frequency (MHz)	EIRP (dBm)	Limit (dBm)	Over Limit (dB)	SPA Reading (dBm)	S.G. Power (dBm)	TX Cable loss (dB)	TX Antenna Gain (dBi)	Polarization (H/V)	Result
3759	-51.96	-13	-38.96	-66.16	-56.56	3	7.60	H	Pass
5640	-47.79	-13	-34.79	-61.58	-54.05	3.84	10.10	H	Pass
7521	-44.02	-13	-31.02	-63.80	-51.52	4.43	11.93	H	Pass

Band :	WCDMA Band II for CH9400	Temperature :	23~25°C						
Test Mode :	RMC 12.2Kbps Link (QPSK)	Relative Humidity :	42~58%						
Test Engineer :	Lewis He	Polarization :	Vertical						
Remark :	Spurious emissions within 30-1000MHz were found more than 20dB below limit line.								
Frequency (MHz)	EIRP (dBm)	Limit (dBm)	Over Limit (dB)	SPA Reading (dBm)	S.G. Power (dBm)	TX Cable loss (dB)	TX Antenna Gain (dBi)	Polarization (H/V)	Result
3759	-53.36	-13	-40.36	-65.85	-57.96	3	7.60	V	Pass
5640	-49.33	-13	-36.33	-61.74	-55.59	3.84	10.10	V	Pass
7521	-46.05	-13	-33.05	-63.84	-53.55	4.43	11.93	V	Pass



Band :	WCDMA Band II for CH9538	Temperature :	23~25°C						
Test Mode :	RMC 12.2Kbps Link (QPSK)	Relative Humidity :	42~58%						
Test Engineer :	Lewis He	Polarization :	Horizontal						
Remark :	Spurious emissions within 30-1000MHz were found more than 20dB below limit line.								
Frequency (MHz)	EIRP (dBm)	Limit (dBm)	Over Limit (dB)	SPA Reading (dBm)	S.G. Power (dBm)	TX Cable loss (dB)	TX Antenna Gain (dBi)	Polarization (H/V)	Result
3816	-52.03	-13	-39.03	-66.23	-56.63	3	7.60	H	Pass
5723	-46.77	-13	-33.77	-60.56	-53.03	3.84	10.10	H	Pass
7629	-43.63	-13	-30.63	-63.41	-51.13	4.43	11.93	H	Pass

Band :	WCDMA Band II for CH9538	Temperature :	23~25°C						
Test Mode :	RMC 12.2Kbps Link (QPSK)	Relative Humidity :	42~58%						
Test Engineer :	Lewis He	Polarization :	Vertical						
Remark :	Spurious emissions within 30-1000MHz were found more than 20dB below limit line.								
Frequency (MHz)	EIRP (dBm)	Limit (dBm)	Over Limit (dB)	SPA Reading (dBm)	S.G. Power (dBm)	TX Cable loss (dB)	TX Antenna Gain (dBi)	Polarization (H/V)	Result
3816	-53.43	-13	-40.43	-65.92	-58.03	3	7.60	V	Pass
5723	-48.52	-13	-35.52	-60.93	-54.78	3.84	10.10	V	Pass
7629	-45.27	-13	-32.27	-63.06	-52.77	4.43	11.93	V	Pass



3.8 Frequency Stability Measurement

3.8.1 Description of Frequency Stability Measurement

The frequency stability shall be measured by variation of ambient temperature and variation of primary supply voltage to ensure that the fundamental emission stays within the authorized frequency block. The frequency stability of the transmitter shall be maintained within $\pm 0.00025\%$ ($\pm 2.5\text{ppm}$) of the center frequency.

3.8.2 Measuring Instruments

The measuring equipment is listed in the section 4 of this test report.

3.8.3 Test Procedures for Temperature Variation

1. The testing follows FCC KDB 971168 v02r02 Section 9.0.
2. The EUT was set up in the thermal chamber and connected with the system simulator.
3. With power OFF, the temperature was decreased to -30°C and the EUT was stabilized before testing. Power was applied and the maximum change in frequency was recorded within one minute.
4. With power OFF, the temperature was raised in 10°C steps up to 50°C . The EUT was stabilized at each step for at least half an hour. Power was applied and the maximum frequency change was recorded within one minute.

3.8.4 Test Procedures for Voltage Variation

1. The testing follows FCC KDB 971168 v02r02 Section 9.0.
2. The EUT was placed in a temperature chamber at $25\pm 5^{\circ}\text{C}$ and connected with the system simulator.
3. The power supply voltage to the EUT was varied from BEP to 115% of the nominal value measured at the input to the EUT.
4. The variation in frequency was measured for the worst case.

3.8.5 Test Setup

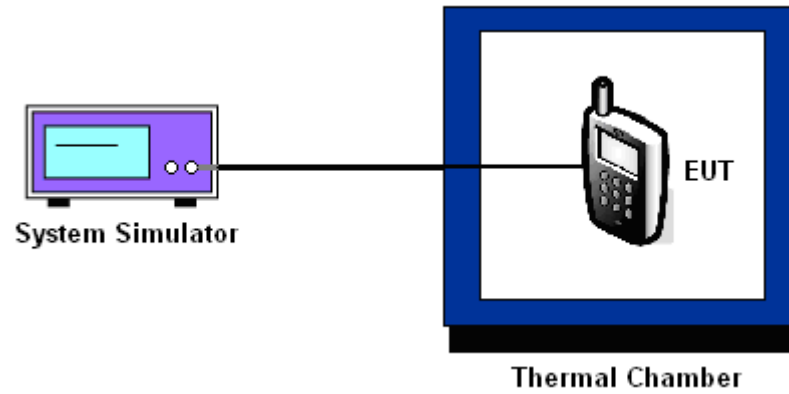



3.8.6 Test Result of Temperature Variation

Band :	GSM 850	Channel :	189
Limit (ppm) :	2.5	Frequency :	836.4 MHz

Temperature (°C)	GSM	EDGE class 8	Result
	Deviation (ppm)	Deviation (ppm)	
50	0.0251	0.0179	PASS
40	0.0108	0.0120	
30	0.0036	0.0060	
20(Ref.)	0.0000	0.0000	
10	0.0048	0.0024	
0	0.0096	0.0060	
-10	0.0155	0.0120	
-20	0.0215	0.0155	
-30	0.0287	0.0203	

Band :	GSM 1900	Channel :	661
Limit (ppm) :	within authorized band	Frequency :	1880.0 MHz

Temperature (°C)	GSM	EDGE class 8	Result
	Deviation (ppm)	Deviation (ppm)	
50	0.0096	0.0133	PASS
40	0.0069	0.0074	
30	0.0011	0.0043	
20(Ref.)	0.0000	0.0000	
10	0.0021	0.0027	
0	0.0037	0.0048	
-10	0.0074	0.0080	
-20	0.0085	0.0106	
-30	0.0106	0.0122	

Note: The frequency fundamental emissions stay within the authorized frequency block based on the frequency deviation measured is small.



Band :	WCDMA Band V	Channel :	4182
Limit (ppm) :	2.5	Frequency :	836.4 MHz

Temperature (°C)	RMC 12.2Kbps	Result
	Deviation (ppm)	
50	0.0251	PASS
40	0.0191	
30	0.0060	
20(Ref.)	0.0000	
10	0.0036	
0	0.0072	
-10	0.0132	
-20	0.0179	
-30	0.0227	

Band :	WCDMA Band IV	Channel :	1413
Limit (ppm) :	within authorized band	Frequency :	1732.6 MHz

Temperature (°C)	RMC 12.2Kbps	Result
	Deviation (ppm)	
50	0.0023	PASS
40	0.0029	
30	0.0052	
20(Ref.)	0.0000	
10	0.0046	
0	0.0075	
-10	0.0081	
-20	0.0150	
-30	0.0023	

Note: The frequency fundamental emissions stay within the authorized frequency block based on the frequency deviation measured is small.



Band :	WCDMA Band II	Channel :	9400
Limit (ppm) :	within authorized band	Frequency :	1880.0 MHz

Temperature (°C)	RMC 12.2Kbps	Result
	Deviation (ppm)	
50	0.0096	PASS
40	0.0069	
30	0.0032	
20(Ref.)	0.0000	
10	0.0016	
0	0.0059	
-10	0.0085	
-20	0.0106	
-30	0.0122	

Note: The frequency fundamental emissions stay within the authorized frequency block based on the frequency deviation measured is small.

3.8.7 Test Result of Voltage Variation

Band & Channel	Mode	Voltage (Volt)	Deviation (ppm)	Limit (ppm)	Result
GSM 850 CH189	GSM	4.35	0.0024	2.5	PASS
		3.80	0.0036		
		BEP	0.0012		
	EDGE class 8	4.35	0.0048		
		3.80	0.0060		
		BEP	0.0072		
GSM 1900 CH661	GSM	4.35	0.0005	(Note 3.)	
		3.80	0.0016		
		BEP	0.0021		
	EDGE class 8	4.35	0.0021		
		3.80	0.0027		
		BEP	0.0011		
WCDMA Band V CH4182	RMC 12.2Kbps	4.35	0.0012	2.5	
		3.80	0.0060		
		BEP	0.0024		
WCDMA Band IV CH1413	RMC 12.2Kbps	4.35	0.0006	(Note 3.)	
		3.80	0.0012		
		BEP	0.0017		
WCDMA Band II CH9400	RMC 12.2Kbps	4.35	0.0016	(Note 3.)	
		3.80	0.0000		
		BEP	0.0005		

Note:

1. Normal Voltage = 3.80V.
2. Battery End Point (BEP) = 3.40 V.
3. The frequency fundamental emissions stay within the authorized frequency block based on the frequency deviation measured is small.



4 List of Measuring Equipment

Instrument	Manufacturer	Model No.	Serial No.	Characteristics	Calibration Date	Test Date	Due Date	Remark
Spectrum Analyzer	R&S	FSP40	100319	9kHz~40GHz	Oct. 28, 2014	Apr. 02, 2015~ Jun. 04, 2015	Oct. 27, 2015	Conducted (TH01-KS)
Spectrum Analyzer	R&S	FSV30	100845	9kHz~30GHz	Oct. 28, 2014	Apr. 02, 2015~ Jun. 04, 2015	Oct. 27, 2015	Conducted (TH01-KS)
Thermal Chamber	Ten Billion	TTC-B3S	TBN-960502	-40~+150°C	Oct. 25, 2014	Apr. 02, 2015~ Jun. 04, 2015	Oct. 24, 2015	Conducted (TH01-KS)
EMI Test Receiver	R&S	ESR7	101403	9kHz~7GHz; Max 30dBm	Sep. 29, 2014	May 27, 2015	Sep. 28, 2015	Radiation (03CH02-KS)
Spectrum Analyzer	R&S	FSV40	101040	10kHz~40GHz;Ma x 30dBm	Sep. 25, 2014	May 27, 2015	Sep. 24, 2015	Radiation (03CH02-KS)
Bilog Antenna	TeseQ	CBL6112D	37879	30MHz~2GHz	Sep. 13, 2014	May 27, 2015	Sep. 12, 2015	Radiation (03CH02-KS)
Double Ridge Horn Antenna	ETS-Lindgren	3117	75957	1GHz~18GHz	Nov. 08, 2014	May 27, 2015	Nov. 07, 2015	Radiation (03CH02-KS)
Active Horn Antenna	com-power	AHA-118	701030	1GHz~18GHz	Nov. 08, 2014	May 27, 2015	Nov. 07, 2015	Radiation (03CH02-KS)
SHF-EHF Horn	com-power	AH-840	101070	18GHz~40GHz	Sep. 04, 2014	May 27, 2015	Sep. 03, 2015	Radiation (03CH02-KS)
Amplifier	com-power	PA-103A	161069	1kHz~1000MHz / 32 dB	May 04, 2015	May 27, 2015	May 03, 2016	Radiation (03CH02-KS)
Amplifier	Agilent	8449B	3008A02384	1GHz~26.5GHz Gain 30dB	Oct. 28, 2014	May 27, 2015	Oct. 27, 2015	Radiation (03CH02-KS)
AC Power Source	Chroma	61601	61601000247 3	N/A	NCR	May 27, 2015	NCR	Radiation (03CH02-KS)
Turn Table	MF	MF7802	N/A	0~360 degree	NCR	May 27, 2015	NCR	Radiation (03CH02-KS)
Antenna Mast	MF	MF7802	N/A	1 m~4 m	NCR	May 27, 2015	NCR	Radiation (03CH02-KS)



5 Uncertainty of Evaluation

Uncertainty of Radiated Emission Measurement (30 MHz ~ 1000 MHz)

Measuring Uncertainty for a Level of Confidence of 95% ($U = 2Uc(y)$)	5.1 dB
---	--------



APPENDIX B. Product Equality Declaration

LTE Band 4	NO	No	No	No	No	No	No	No	No
LTE Band 5	NO	No	No	No	No	No	No	No	No
LTE Band 7	NO	No	No	No	No	No	No	No	No
LTE Band 12	NO	No	No	No	No	No	Yes	Yes	No
LTE Band 17	NO	No	No	No	No	No	Yes	Yes	No

	Antenna	AP	Modem	Transceiver	Power Amplifier	Balun	Band pass filter	Diplexer
Bluetooth	No	No	No	No	No	No	No	No
Wi-Fi	No	No	No	No	No	No	No	No

- FM changes: No
- LCD/ Speaker/ Camera/ Vibrator changes: No (indicated the changed items if yes)
- Other changes detailed:

● **MECHANICAL MODIFICATIONS:**

- Use new metal front/back cover or keypad: No
- Mechanical shell changes:
Whole size of EUT: No
Distance of Ear reference point to bottom of handset: No
Other trinkets to change the surface of handset: No
- Other changes detailed:

APPROVED BY:

Project Manager:

Signature:

Date:

Daniel Ji
2015.3.18