



SAR TEST REPORT

No. I14Z49088-SEM01

For

TCT Mobile Limited

CDMA EVDO BC0/BC1/LTE 1 band Mobile phone

Model Name: Alto-4 EVDO

Marketing Name: A520L

With

Hardware Version: PIO

Software Version: 5NPF

FCC ID: RAD535

Issued Date: 2015-01-28

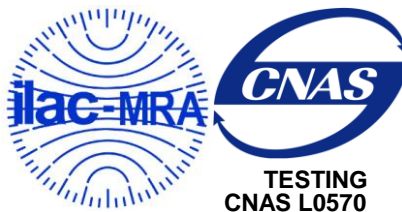

Note:

The test results in this test report relate only to the devices specified in this report. This report shall not be reproduced except in full without the written approval of CTTL.

Test Laboratory:

CTTL, Telecommunication Technology Labs, Academy of Telecommunication Research, MIIT
No. 51 Shouxiang Science Building, Xueyuan Road, Haidian District, Beijing, P. R. China100191
Tel:+86(0)10-62304633-2512,Fax:+86(0)10-62304633-2504
Email:ctl_terminals@catr.cn, website:www.chinattl.com



REPORT HISTORY

Report Number	Revision	Issue Date	Description
I14Z49088-SEM01	Rev.0	2015-01-21	Initial creation of test report
I14Z49088-SEM01	Rev.1	2015-01-28	<ol style="list-style-type: none">1. Update the standard version in section 5.2 on page 92. Remove the evaluation of test position on page 253. Add the note in annex E on page 734. Revise the title of table 15.1 on page 33



TABLE OF CONTENT

1 TEST LABORATORY	5
1.1 TESTING LOCATION	5
1.2 TESTING ENVIRONMENT	5
1.3 PROJECT DATA.....	5
1.4 SIGNATURE.....	5
2 STATEMENT OF COMPLIANCE	6
3 CLIENT INFORMATION	7
3.1 APPLICANT INFORMATION	7
3.2 MANUFACTURER INFORMATION	7
4 EQUIPMENT UNDER TEST (EUT) AND ANCILLARY EQUIPMENT (AE)	8
4.1 ABOUT EUT.....	8
4.2 INTERNAL IDENTIFICATION OF EUT USED DURING THE TEST	8
4.3 INTERNAL IDENTIFICATION OF AE USED DURING THE TEST.....	8
5 TEST METHODOLOGY	9
5.1 APPLICABLE LIMIT REGULATIONS	9
5.2 APPLICABLE MEASUREMENT STANDARDS.....	9
6 SPECIFIC ABSORPTION RATE (SAR).....	10
6.1 INTRODUCTION.....	10
6.2 SAR DEFINITION	10
7 TISSUE SIMULATING LIQUIDS	11
7.1 TARGETS FOR TISSUE SIMULATING LIQUID	11
7.2 DIELECTRIC PERFORMANCE	11
8 SYSTEM VERIFICATION	16
8.1 SYSTEM SETUP	16
8.2 SYSTEM VERIFICATION.....	17
9 MEASUREMENT PROCEDURES	18
9.1 TESTS TO BE PERFORMED.....	18
9.2 GENERAL MEASUREMENT PROCEDURE	19
9.3 BLUETOOTH & WI-FI MEASUREMENT PROCEDURES FOR SAR	20
9.4 POWER DRIFT	21
10 AREA SCAN BASED 1-G SAR.....	21
10.1 REQUIREMENT OF KDB.....	21
10.2 FAST SAR ALGORITHMS.....	21
11 CONDUCTED OUTPUT POWER.....	22
11.1 MANUFACTURING TOLERANCE	22



11.2 GSM MEASUREMENT RESULT	23
11.3 LTE MEASUREMENT RESULT	23
11.4 WI-FI AND BT MEASUREMENT RESULT	24
12 SIMULTANEOUS TX SAR CONSIDERATIONS	25
12.1 INTRODUCTION	25
12.2 TRANSMIT ANTENNA SEPARATION DISTANCES	25
12.3 STANDALONE SAR TEST EXCLUSION CONSIDERATIONS	26
13 EVALUATION OF SIMULTANEOUS	27
14 SAR TEST RESULT	28
14.1 SAR RESULTS FOR FAST SAR	28
14.2 SAR RESULTS FOR STANDARD PROCEDURE	31
15 SAR MEASUREMENT VARIABILITY	33
16 MEASUREMENT UNCERTAINTY	34
17 MAIN TEST INSTRUMENTS	38
ANNEX A GRAPH RESULTS	39
ANNEX B SYSTEM VERIFICATION RESULTS	55
ANNEX C SAR MEASUREMENT SETUP	64
ANNEX D POSITION OF THE WIRELESS DEVICE IN RELATION TO THE PHANTOM	70
ANNEX E EQUIVALENT MEDIA RECIPES	73
ANNEX F SYSTEM VALIDATION	74
ANNEX G PROBE CALIBRATION CERTIFICATE	75
ANNEX H DIPOLE CALIBRATION CERTIFICATE	86
ANNEX I ACCREDITATION CERTIFICATE	118

1 Test Laboratory

1.1 Testing Location

Company Name:	CTTL(Shouxiang)
Address:	No. 51 Shouxiang Science Building, Xueyuan Road, Haidian District, Beijing, P. R. China100191

1.2 Testing Environment

Temperature:	18°C~25 °C,
Relative humidity:	30%~ 70%
Ground system resistance:	< 0.5 Ω
Ambient noise & Reflection:	< 0.012 W/kg

1.3 Project Data

Project Leader:	Qi Dianyuan
Test Engineer:	Lin Xiaojun
Testing Start Date:	December 23, 2014
Testing End Date:	December 26, 2014

1.4 Signature



Lin Xiaojun
(Prepared this test report)

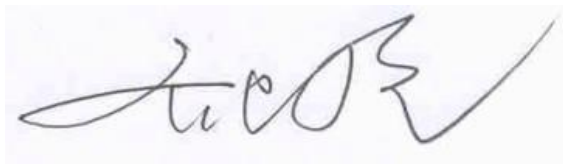

Qi Dianyuan
(Reviewed this test report)



Xiao Li
Deputy Director of the laboratory
(Approved this test report)

2 Statement of Compliance

The maximum results found during testing for TCT Mobile Limited CDMA EVDO BC0/BC1/LTE 1 band Mobile phone Alto-4 EVDO / A520L are as follows:

Table 2.1: Highest Reported SAR (1g)

Exposure Configuration	Technology Band	Highest Reported SAR 1g (W/Kg)	Equipment Class
Head (Separation Distance 0mm)	CDMA BC0	0.89	PCE
	CDMA BC1	1.31	
	LTE Band 13	0.92	
	WLAN 2.4 GHz	0.58	DTS
Body-worn (Separation Distance 15mm)	CDMA BC0	0.59	PCE
	CDMA BC1	0.63	
	LTE Band 13	0.81	
	WLAN 2.4 GHz	0.10	DTS

The SAR values found for the Mobile Phone are below the maximum recommended levels of 1.6 W/Kg as averaged over any 1g tissue according to the ANSI C95.1-1999.

For body worn operation, this device has been tested and meets FCC RF exposure guidelines when used with any accessory that contains no metal and which provides a minimum separation distance of 15 mm between this device and the body of the user. Use of other accessories may not ensure compliance with FCC RF exposure guidelines.

The EUT battery must be fully charged and checked periodically during the test to ascertain uniform power output.

The measurement together with the test system set-up is described in annex C of this test report. A detailed description of the equipment under test can be found in chapter 4 of this test report.

The highest reported SAR value is obtained at the case of **(Table 2.1)**, and the values are: **1.31 W/kg (1g)**.

Table 2.2: The sum of reported SAR values for main antenna and WiFi

	Position	Main antenna	WiFi	Sum
Highest reported SAR value for Head	Left hand, Touch cheek	0.85	0.58	1.43
	Right hand, Touch cheek	1.31	0.28	1.59
Highest reported SAR value for Body	Rear	0.81	0.10	0.91

Table 2.3: The sum of reported SAR values for main antenna and Bluetooth

	Position	Main antenna	BT*	Sum
Highest reported SAR value for Head	Right hand, Touch cheek	1.31	0.26	1.57
Highest reported SAR value for Body	Rear	0.81	0.13	0.94

BT* - Estimated SAR for Bluetooth (see the table 13.3)

According to the above tables, the highest sum of reported SAR values is **1.59 W/kg (1g)**. The detail for simultaneous transmission consideration is described in chapter 13.



3 Client Information

3.1 Applicant Information

Company Name:	TCT Mobile Limited
Address /Post:	5F, E building, No. 232, Liang Jing Road ZhangJiang High-Tech Park, Pudong Area Shanghai, P.R. China. 201203
City:	Shanghai
Postal Code:	201203
Country:	P.R.China
Contact:	Gong Zhizhou
Email:	zhizhou.gong@jrdcom.com
Telephone:	0086-21-6146089
Fax:	0086-21-61460602

3.2 Manufacturer Information

Company Name:	TCT Mobile Limited
Address /Post:	5F, E building, No. 232, Liang Jing Road ZhangJiang High-Tech Park, Pudong Area Shanghai, P.R. China. 201203
City:	Shanghai
Postal Code:	201203
Country:	P.R.China
Contact:	Gong Zhizhou
Email:	zhizhou.gong@jrdcom.com
Telephone:	0086-21-6146089
Fax:	0086-21-61460602

4 Equipment Under Test (EUT) and Ancillary Equipment (AE)

4.1 About EUT

Description:	CDMA EVDO BC0/BC1/LTE 1 band Mobile phone
Model Name:	Alto-4 EVDO
Marketing Name:	A520L
Operating mode(s):	CDMA BC0/1, LTE Band13, BT, Wi-Fi
Tested Tx Frequency:	824.7 – 848.31 MHz (CDMA BC0)
	1851.25 – 1908.75 MHz (CDMA BC1)
	779.5 – 784.5 MHz (LTE Band13)
	2412 – 2462 MHz (Wi-Fi 2.4G)
Test device Production information:	Production unit
Device type:	Portable device
Antenna type:	Integrated antenna

4.2 Internal Identification of EUT used during the test

EUT ID*	IMEI	HW Version	SW Version
EUT1	866274020005389	PIO	5NPF
EUT2	866274020005363	PIO	5NPF
EUT3	866274020005355	PIO	5NPF

*EUT ID: is used to identify the test sample in the lab internally.

Note: It is performed to test SAR with the EUT1&2 and conducted power with the EUT 3.

4.3 Internal Identification of AE used during the test

AE ID*	Description	Model	SN	Manufacturer
AE1	Battery	TLi020F2	/	SCUD

*AE ID: is used to identify the test sample in the lab internally.



5 TEST METHODOLOGY

5.1 Applicable Limit Regulations

ANSI C95.1–1999: IEEE Standard for Safety Levels with Respect to Human Exposure to Radio Frequency Electromagnetic Fields, 3 kHz to 300 GHz.

It specifies the maximum exposure limit of **1.6 W/kg** as averaged over any 1 gram of tissue for portable devices being used within 20 cm of the user in the uncontrolled environment.

5.2 Applicable Measurement Standards

IEEE 1528–2013: Recommended Practice for Determining the Peak Spatial-Average Specific Absorption Rate (SAR) in the Human Head from Wireless Communications Devices: Experimental Techniques.

KDB447498 D01: General RF Exposure Guidance v05r02: Mobile and Portable Devices RF Exposure Procedures and Equipment Authorization Policies.

KDB648474 D04 Handset SAR v01r02: SAR Evaluation Considerations for Wireless Handsets.

KDB941225 D01 SAR test for 3G devices v03: SAR Measurement Procedures for 3G Devices.

KDB941225 D05 SAR for LTE Devices v02r03: SAR Evaluation Considerations for LTE Devices

KDB941225 D06 Hotspot Mode SAR v02: SAR Evaluation Procedures for Portable Devices with Wireless Router Capabilities.

KDB248227 D01 SAR meas for 802 11 a b g v01r02 : SAR measurement procedures for 802.112abg transmitters.

KDB 865664 D01 SAR measurement 100 MHz to 6 GHz v01r03: SAR Measurement Requirements for 100 MHz to 6 GHz.

KDB 865664 D02 RF Exposure Reporting v01r01: RF Exposure Compliance Reporting and Documentation Considerations

6 Specific Absorption Rate (SAR)

6.1 Introduction

SAR is related to the rate at which energy is absorbed per unit mass in an object exposed to a radio field. The SAR distribution in a biological body is complicated and is usually carried out by experimental techniques or numerical modeling. The standard recommends limits for two tiers of groups, occupational/controlled and general population/uncontrolled, based on a person's awareness and ability to exercise control over his or her exposure. In general, occupational/controlled exposure limits are higher than the limits for general population/uncontrolled.

6.2 SAR Definition

The SAR definition is the time derivative (rate) of the incremental energy (dW) absorbed by (dissipated in) an incremental mass (dm) contained in a volume element (dv) of a given density (ρ). The equation description is as below:

$$SAR = \frac{d}{dt} \left(\frac{dW}{dm} \right) = \frac{d}{dt} \left(\frac{dW}{\rho dv} \right)$$

SAR is expressed in units of Watts per kilogram (W/kg)

SAR measurement can be either related to the temperature elevation in tissue by

$$SAR = c \left(\frac{\delta T}{\delta t} \right)$$

Where: C is the specific heat capacity, δT is the temperature rise and δt is the exposure duration, or related to the electrical field in the tissue by

$$SAR = \frac{\sigma |E|^2}{\rho}$$

Where: σ is the conductivity of the tissue, ρ is the mass density of tissue and E is the RMS electrical field strength.

However for evaluating SAR of low power transmitter, electrical field measurement is typically applied.

7 Tissue Simulating Liquids

7.1 Targets for tissue simulating liquid

Table 7.1: Targets for tissue simulating liquid

Frequency (MHz)	Liquid Type	Conductivity (σ)	$\pm 5\%$ Range	Permittivity (ϵ)	$\pm 5\%$ Range
750	Head	0.89	0.85~0.93	41.94	39.8~44.0
750	Body	0.96	0.91~1.01	55.5	52.7~58.3
835	Head	0.90	0.86~0.95	41.5	39.4~43.6
835	Body	0.97	0.92~1.02	55.2	52.4~58.0
1900	Head	1.40	1.33~1.47	40.0	38.0~42.0
1900	Body	1.52	1.44~1.60	53.3	50.6~56.0
2450	Head	1.80	1.71~1.89	39.2	37.2~41.2
2450	Body	1.95	1.85~2.05	52.7	50.1~55.3

7.2 Dielectric Performance

Table 7.2: Dielectric Performance of Tissue Simulating Liquid

Measurement Date (yyyy-mm-dd)	Type	Frequency	Permittivity ϵ	Drift (%)	Conductivity σ (S/m)	Drift (%)
2014-12-23	Head	750 MHz	43.35	3.36	0.869	-2.36
	Body	750 MHz	55.53	0.05	0.925	-3.65
2014-12-24	Head	835 MHz	42.7	2.89	0.936	4.00
	Body	835 MHz	54.85	-0.63	0.963	-0.72
2014-12-25	Head	1900 MHz	40.18	0.45	1.389	-0.79
	Body	1900 MHz	54.06	1.43	1.508	-0.79
2014-12-26	Head	2450 MHz	40.2	2.55	1.84	2.22
	Body	2450 MHz	50.88	-3.45	2.018	3.49

Note: The liquid temperature is 22.0°C

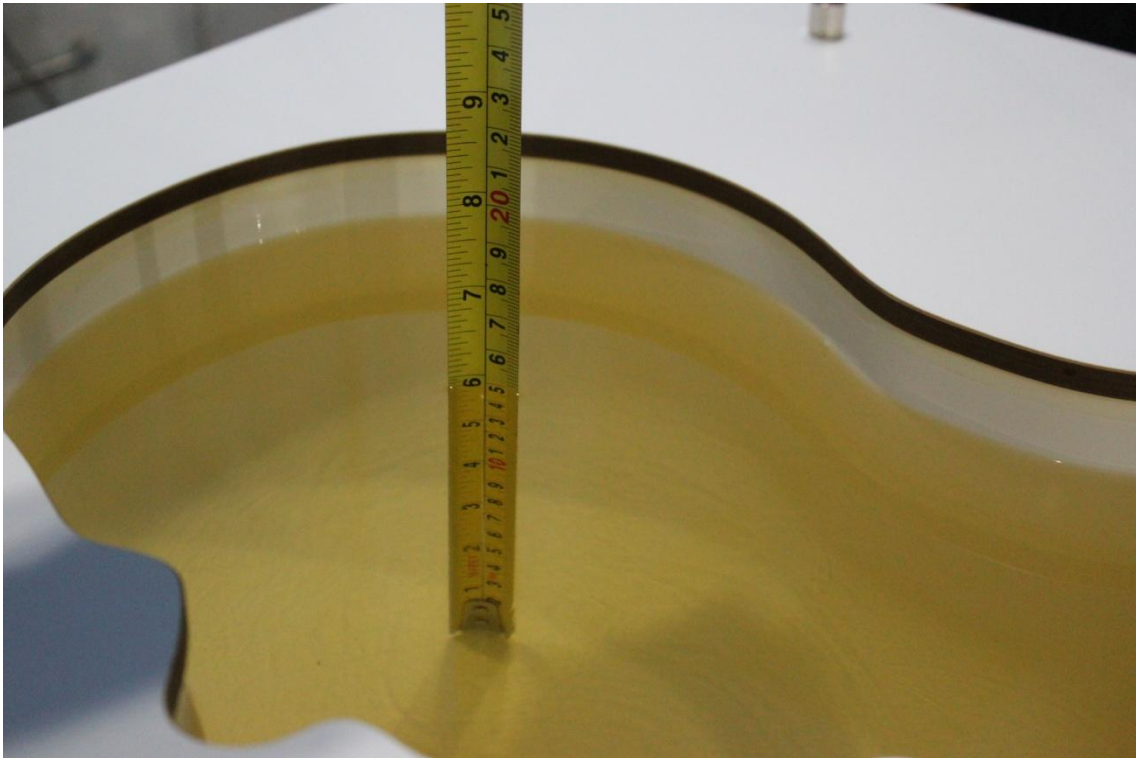

Picture 7-1: Liquid depth in the Head Phantom (750 MHz)



Picture 7-2: Liquid depth in the Flat Phantom (750 MHz)

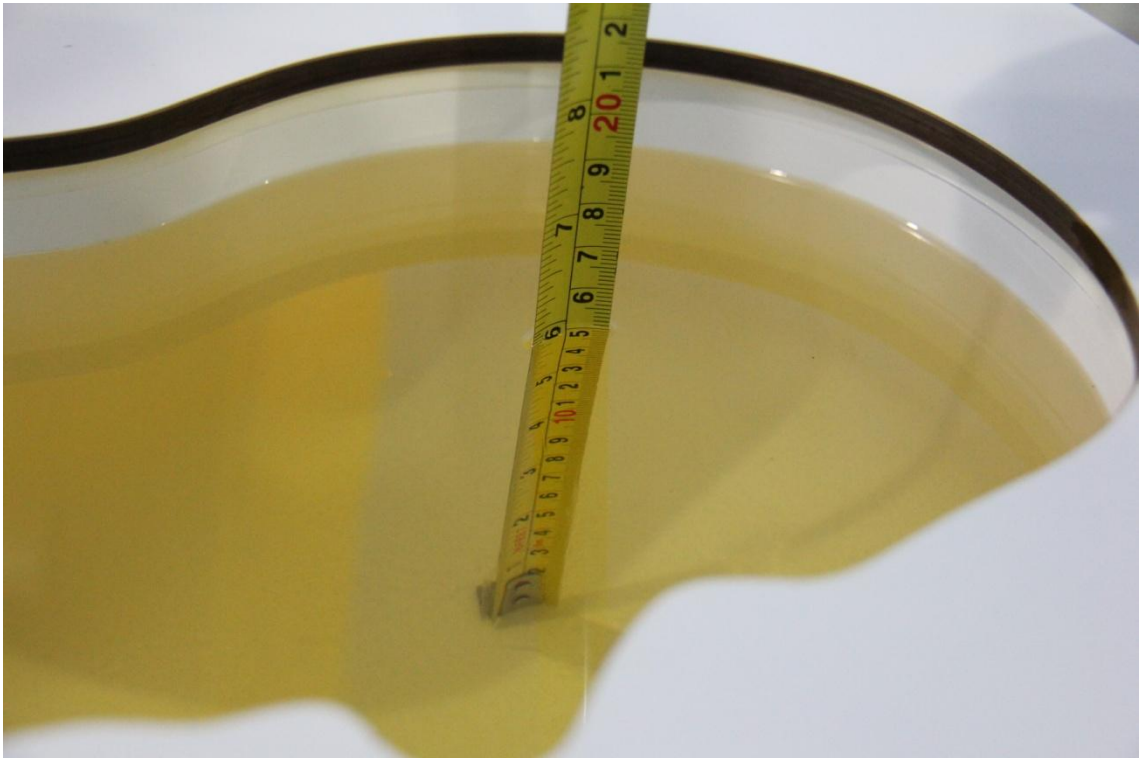

Picture 7-3: Liquid depth in the Head Phantom (835 MHz)

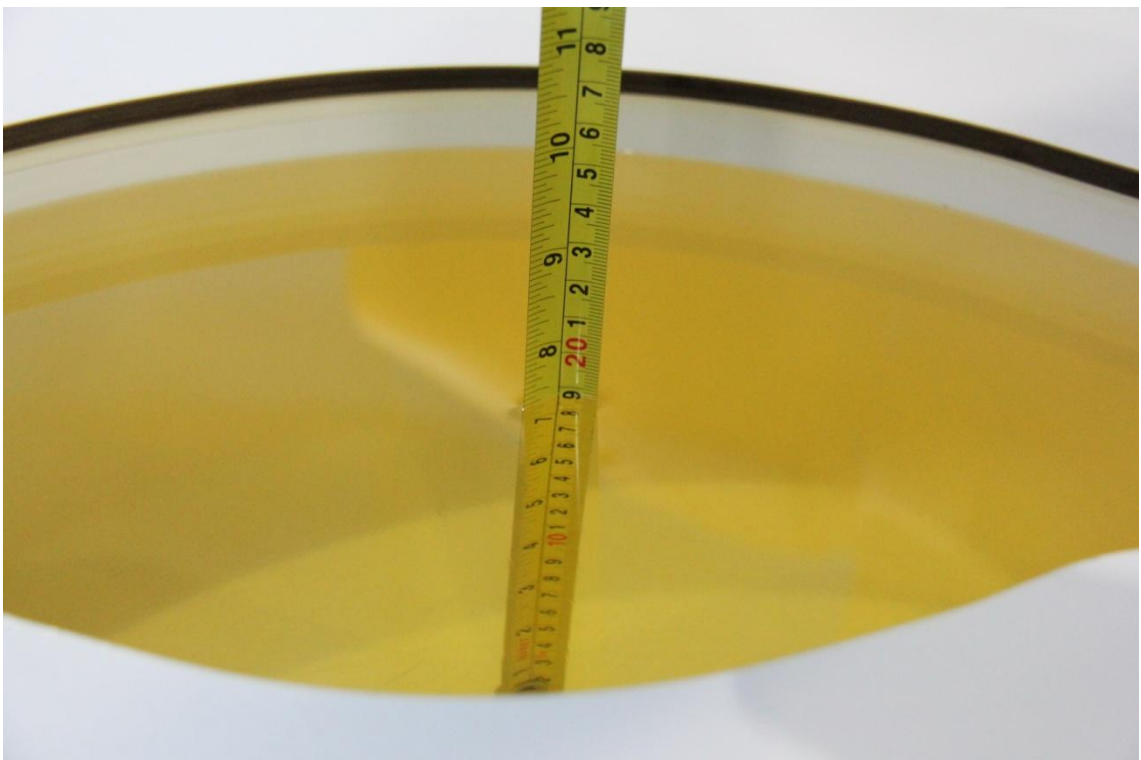

Picture 7-4: Liquid depth in the Flat Phantom (835 MHz)

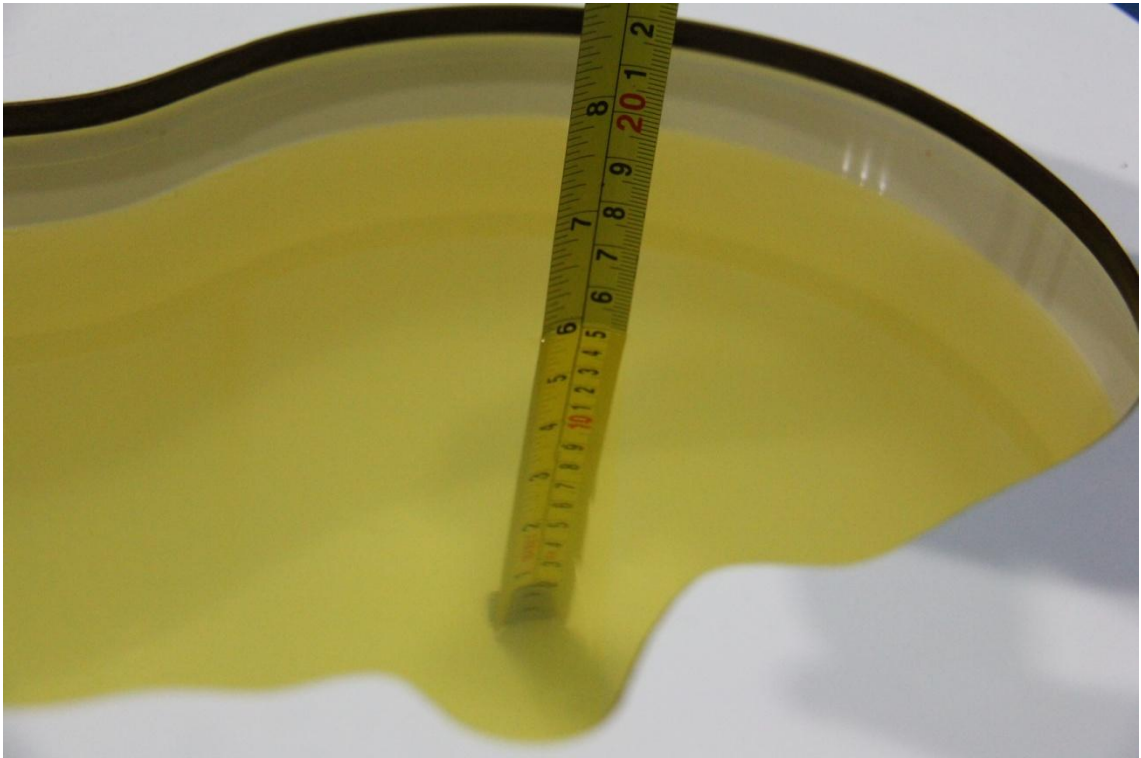

Picture 7-5: Liquid depth in the Head Phantom (1900 MHz)



Picture 7-6 Liquid depth in the Flat Phantom (1900MHz)

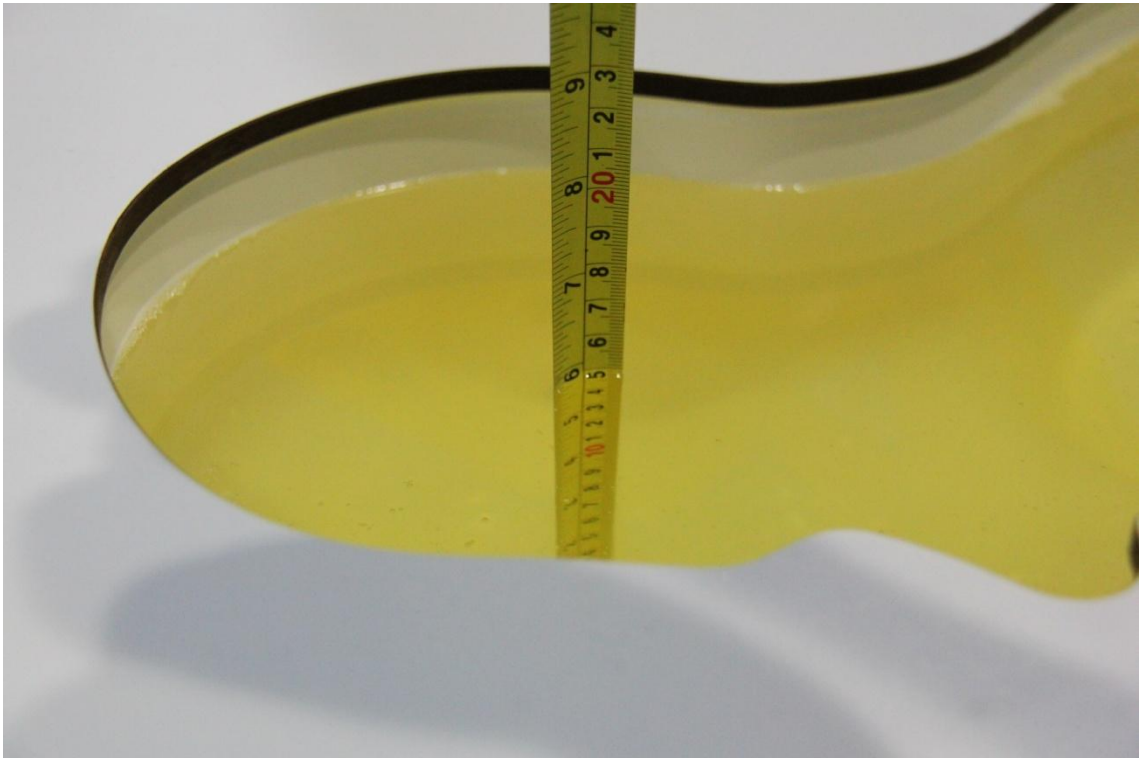

Picture 7-7 Liquid depth in the Head Phantom (2450MHz)

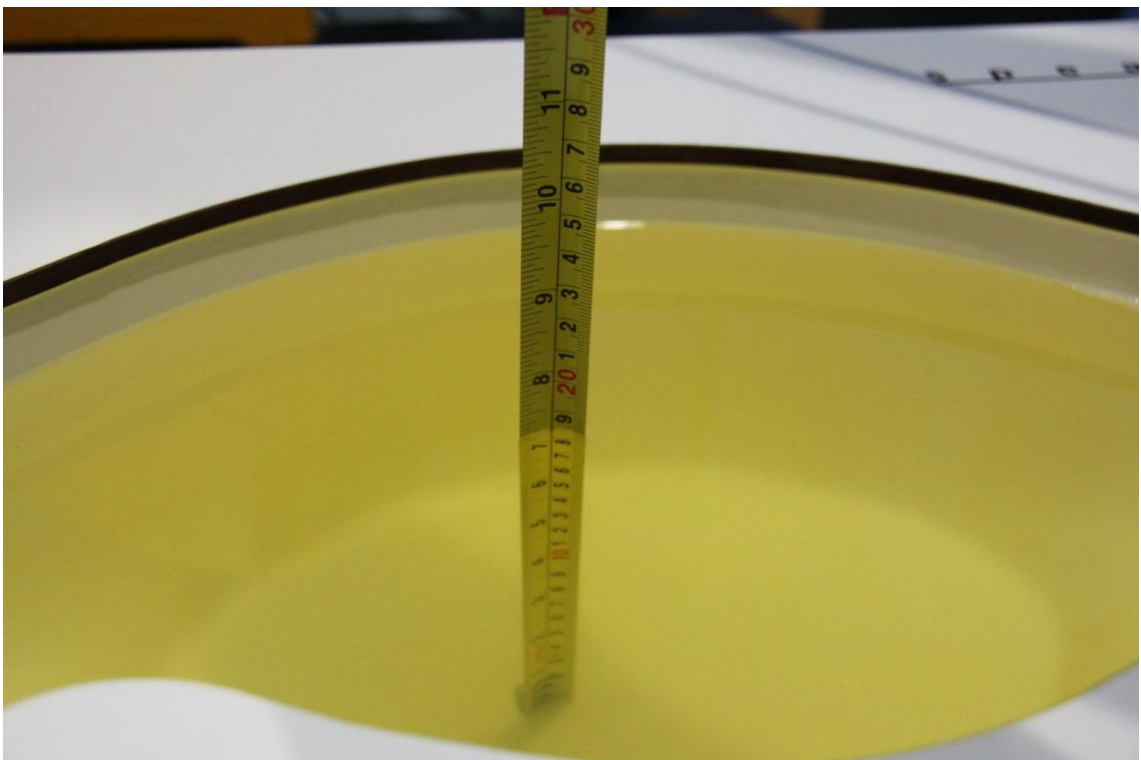

Picture 7-8 Liquid depth in the Flat Phantom (2450MHz)

8 System verification

8.1 System Setup

In the simplified setup for system evaluation, the DUT is replaced by a calibrated dipole and the power source is replaced by a continuous wave that comes from a signal generator. The calibrated dipole must be placed beneath the flat phantom section of the SAM twin phantom with the correct distance holder. The distance holder should touch the phantom surface with a light pressure at the reference marking and be oriented parallel to the long side of the phantom. The equipment setup is shown below:

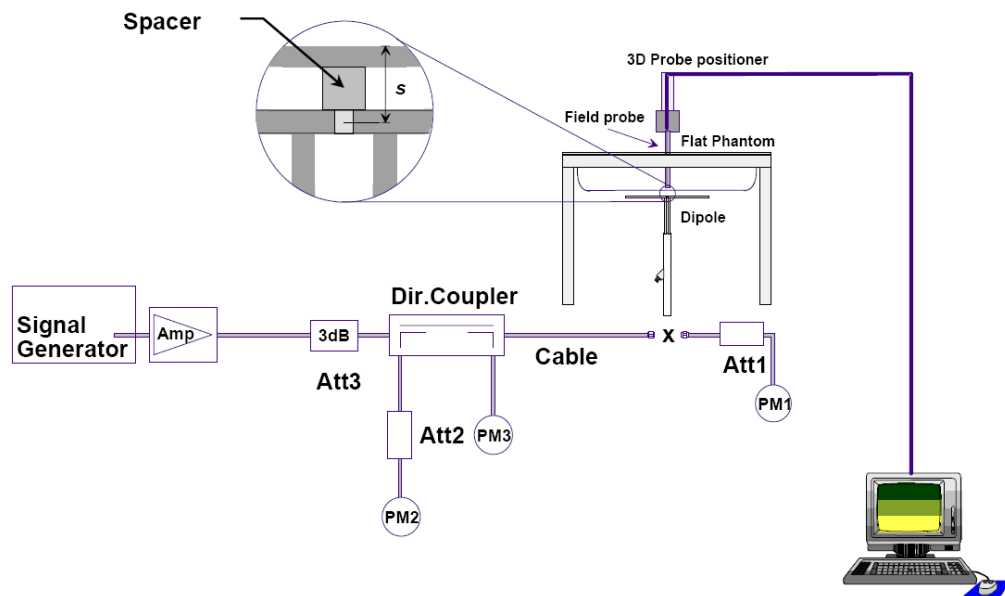

Picture 8.1 System Setup for System Evaluation



Picture 8.2 Photo of Dipole Setup

8.2 System Verification

SAR system verification is required to confirm measurement accuracy, according to the tissue dielectric media, probe calibration points and other system operating parameters required for measuring the SAR of a test device. The system verification must be performed for each frequency band and within the valid range of each probe calibration point required for testing the device.

The system verification results are required that the area scan estimated 1-g SAR is within 3% of the zoom scan 1-g SAR. The details are presented in annex B.

Table 8.1: System Verification of Head

Measurement Date (yyyy-mm-dd)	Frequency	Target value (W/kg)		Measured value (W/kg)		Deviation	
		10 g Average	1 g Average	10 g Average	1 g Average	10 g Average	1 g Average
2014-12-23	750 MHz	5.49	8.31	5.60	8.56	2.00%	3.01%
2014-12-24	835 MHz	6.17	9.43	6.28	9.72	1.78%	3.08%
2014-12-25	1900 MHz	21.1	40.6	20.72	39.40	-1.80%	-2.96%
2014-12-26	2450 MHz	24.7	53.2	24.24	52.00	-1.86%	-2.26%

Table 8.2: System Verification of Body

Measurement Date (yyyy-mm-dd)	Frequency	Target value (W/kg)		Measured value (W/kg)		Deviation	
		10 g Average	1 g Average	10 g Average	1 g Average	10 g Average	1 g Average
2014-12-23	750 MHz	5.85	8.75	5.80	8.92	-0.85%	1.94%
2014-12-24	835 MHz	6.33	9.55	6.20	9.52	-2.05%	-0.31%
2014-12-25	1900 MHz	21.4	40.4	21.72	41.20	1.50%	1.98%
2014-12-26	2450 MHz	23.9	51.3	23.36	49.60	-2.26%	-3.31%

9 Measurement Procedures

9.1 Tests to be performed

In order to determine the highest value of the peak spatial-average SAR of a handset, all device positions, configurations and operational modes shall be tested for each frequency band according to steps 1 to 3 below. A flowchart of the test process is shown in picture 9.1.

Step 1: The tests described in 9.2 shall be performed at the channel that is closest to the centre of the transmit frequency band (f_c) for:

- a) all device positions (cheek and tilt, for both left and right sides of the SAM phantom, as described in annex D),
- b) all configurations for each device position in a), e.g., antenna extended and retracted, and
- c) all operational modes, e.g., analogue and digital, for each device position in a) and configuration in b) in each frequency band.

If more than three frequencies need to be tested according to 11.1 (i.e., $N_c > 3$), then all frequencies, configurations and modes shall be tested for all of the above test conditions.

Step 2: For the condition providing highest peak spatial-average SAR determined in Step 1, perform all tests described in 9.2 at all other test frequencies, i.e., lowest and highest frequencies. In addition, for all other conditions (device position, configuration and operational mode) where the peak spatial-average SAR value determined in Step 1 is within 3 dB of the applicable SAR limit, it is recommended that all other test frequencies shall be tested as well.

Step 3: Examine all data to determine the highest value of the peak spatial-average SAR found in Steps 1 to 2.

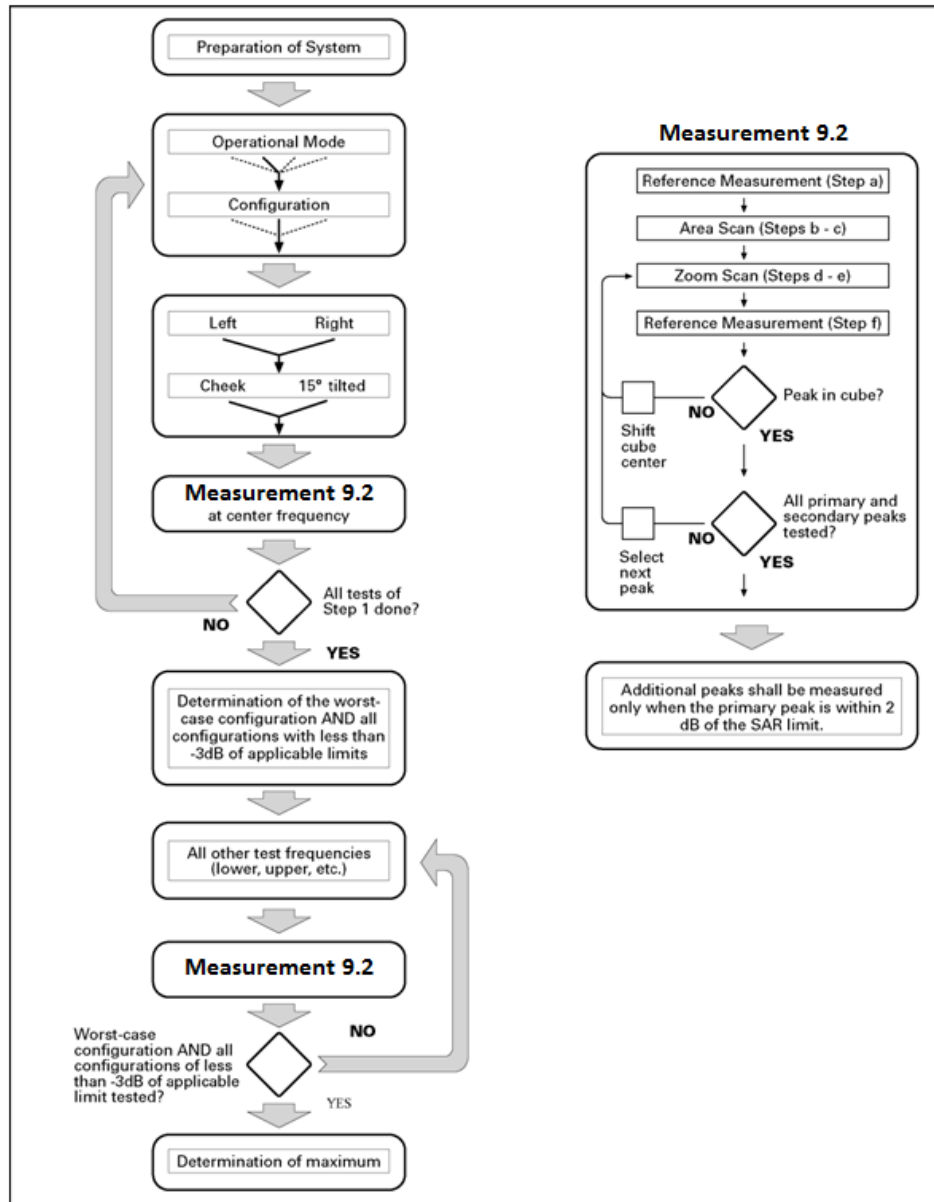

Picture 9.1 Block diagram of the tests to be performed

9.2 General Measurement Procedure

The area and zoom scan resolutions specified in the table below must be applied to the SAR measurements and fully documented in SAR reports to qualify for TCB approval. Probe boundary effect error compensation is required for measurements with the probe tip closer than half a probe tip diameter to the phantom surface. Both the probe tip diameter and sensor offset distance must satisfy measurement protocols; to ensure probe boundary effect errors are minimized and the higher fields closest to the phantom surface can be correctly measured and extrapolated to the phantom surface for computing 1-g SAR. Tolerances of the post-processing algorithms must be verified by the test laboratory for the scan resolutions used in the SAR measurements, according to the reference distribution functions specified in IEEE Std 1528-2003. The results should be documented as part of the system validation records and may be requested to support test results

when all the measurement parameters in the following table are not satisfied.

		≤ 3 GHz	> 3 GHz
Maximum distance from closest measurement point (geometric center of probe sensors) to phantom surface		5 ± 1 mm	$\frac{1}{2} \delta \ln(2) \pm 0.5$ mm
Maximum probe angle from probe axis to phantom surface normal at the measurement location		$30^\circ \pm 1^\circ$	$20^\circ \pm 1^\circ$
Maximum area scan spatial resolution: $\Delta x_{Area}, \Delta y_{Area}$		≤ 2 GHz: ≤ 15 mm 2 – 3 GHz: ≤ 12 mm	3 – 4 GHz: ≤ 12 mm 4 – 6 GHz: ≤ 10 mm
		When the x or y dimension of the test device, in the measurement plane orientation, is smaller than the above, the measurement resolution must be \leq the corresponding x or y dimension of the test device with at least one measurement point on the test device.	
Maximum zoom scan spatial resolution: $\Delta x_{Zoom}, \Delta y_{Zoom}$		≤ 2 GHz: ≤ 8 mm 2 – 3 GHz: ≤ 5 mm*	3 – 4 GHz: ≤ 5 mm* 4 – 6 GHz: ≤ 4 mm*
Maximum zoom scan spatial resolution, normal to phantom surface	uniform grid: $\Delta z_{Zoom}(n)$	≤ 5 mm	3 – 4 GHz: ≤ 4 mm 4 – 5 GHz: ≤ 3 mm 5 – 6 GHz: ≤ 2 mm
	graded grid $\Delta z_{Zoom}(1)$: between 1 st two points closest to phantom surface	≤ 4 mm	3 – 4 GHz: ≤ 3 mm 4 – 5 GHz: ≤ 2.5 mm 5 – 6 GHz: ≤ 2 mm
	$\Delta z_{Zoom}(n>1)$: between subsequent points	$\leq 1.5 \cdot \Delta z_{Zoom}(n-1)$	
Minimum zoom scan volume	x, y, z	≥ 30 mm	3 – 4 GHz: ≥ 28 mm 4 – 5 GHz: ≥ 25 mm 5 – 6 GHz: ≥ 22 mm
Note: δ is the penetration depth of a plane-wave at normal incidence to the tissue medium; see draft standard IEEE P1528-2011 for details. * When zoom scan is required and the <i>reported</i> SAR from the area scan based <i>I-g SAR estimation</i> procedures of KDB 447498 is ≤ 1.4 W/kg, ≤ 8 mm, ≤ 7 mm and ≤ 5 mm zoom scan resolution may be applied, respectively, for 2 GHz to 3 GHz, 3 GHz to 4 GHz and 4 GHz to 6 GHz.			

9.3 Bluetooth & Wi-Fi Measurement Procedures for SAR

Normal network operating configurations are not suitable for measuring the SAR of 802.11 transmitters in general. Unpredictable fluctuations in network traffic and antenna diversity conditions can introduce undesirable variations in SAR results. The SAR for these devices should be measured using chipset based test mode software to ensure that the results are consistent and reliable.

Chipset based test mode software is hardware dependent and generally varies among manufacturers. The device operating parameters established in a test mode for SAR measurements must be identical to those programmed in production units, including output power levels, amplifier gain settings and other RF performance tuning parameters. The test frequencies should correspond to actual channel frequencies defined for domestic use. SAR for devices with switched diversity should be measured with only one antenna transmitting at a time during each SAR measurement, according to a fixed modulation and data rate. The same data pattern should be used for all measurements.

9.4 Power Drift

To control the output power stability during the SAR test, DASY4 system calculates the power drift by measuring the E-field at the same location at the beginning and at the end of the measurement for each test position. These drift values can be found in Table 14.1 to Table 14.16 labeled as: (Power Drift [dB]). This ensures that the power drift during one measurement is within 5%.

10 Area Scan Based 1-g SAR

10.1 Requirement of KDB

According to the KDB447498 D01 v05, when the implementation is based the specific polynomial fit algorithm as presented at the 29th Bioelectromagnetics Society meeting (2007) and the estimated 1-g SAR is ≤ 1.2 W/kg, a zoom scan measurement is not required provided it is also not needed for any other purpose; for example, if the peak SAR location required for simultaneous transmission SAR test exclusion can be determined accurately by the SAR system or manually to discriminate between distinctive peaks and scattered noisy SAR distributions from area scans.

There must not be any warning or alert messages due to various measurement concerns identified by the SAR system; for example, noise in measurements, peaks too close to scan boundary, peaks are too sharp, spatial resolution and uncertainty issues etc. The SAR system verification must also demonstrate that the area scan estimated 1-g SAR is within 3% of the zoom scan 1-g SAR (See Annex B). When all the SAR results for each exposure condition in a frequency band and wireless mode are based on estimated 1-g SAR, the 1-g SAR for the highest SAR configuration must be determined by a zoom scan.

10.2 Fast SAR Algorithms

The approach is based on the area scan measurement applying a frequency dependent attenuation parameter. This attenuation parameter was empirically determined by analyzing a large number of phones. The MOTOROLA FAST SAR was developed and validated by the MOTOROLA Research Group in Ft. Lauderdale.

In the initial study, an approximation algorithm based on Linear fit was developed. The accuracy of the algorithm has been demonstrated across a broad frequency range (136-2450 MHz) and for both 1- and 10-g averaged SAR using a sample of 264 SAR measurements from 55 wireless handsets. For the sample size studied, the root-mean-squared errors of the algorithm are 1.2% and 5.8% for 1- and 10-g averaged SAR, respectively. The paper describing the algorithm in detail is expected to be published in August 2004 within the Special Issue of Transactions on MTT.

In the second step, the same research group optimized the fitting algorithm to an Polynomial fit whereby the frequency validity was extended to cover the range 30-6000MHz. Details of this study can be found in the BEMS 2007 Proceedings.

Both algorithms are implemented in DASY software.

11 Conducted Output Power

11.1 Manufacturing tolerance

Table 11.1: CDMA

CDMA BC0			
Channel	Channel 777	Channel 384	Channel 1013
Target (dBm)	23.3	23.3	23.3
Tune-up (dBm)	24.3	24.3	24.3
CDMA BC1			
Channel	Channel 1175	Channel 600	Channel 25
Target (dBm)	23	23	23
Tune-up (dBm)	24	24	24

Table 11.2: LTE

Mode	Target (dBm)	Tune-up (dBm)
LTE Band 13	23	24

LTE MPR will follow up 3GPP setting as below:

Modulation	Channel bandwidth / Transmission bandwidth (NRB)						MPR (dB)
	1.4MHz	3.0MHz	5MHz	10MHz	15MHz	20MHz	
QPSK	> 5	> 4	> 8	> 12	> 16	> 18	1
16 QAM	≤ 5	≤ 4	≤ 8	≤ 12	≤ 16	≤ 18	1
16 QAM	> 5	> 4	> 8	> 12	> 16	> 18	2

Table 11.3: Bluetooth

Mode	Target (dBm)	Tune-up (dBm)
Bluetooth	6	8

Table 11.4: WiFi

Mode	Target (dBm)	Tune-up (dBm)
802.11 b	16	18
802.11 g, 6Mbps	14	16
802.11 g, 9Mbps~18Mbps	13	15
802.11 g, 24Mbps~36Mbps	12	14
802.11 g, 48Mbps~54Mbps	11	13
802.11 n, MCS0	14	16
802.11 n, MCS1~MCS4	12	14
802.11 n, MCS5~MCS7	8	10

11.2 GSM Measurement result

During the process of testing, the EUT was controlled via Agilent Digital Radio Communication tester (E5515C) to ensure the maximum power transmission and proper modulation. This result contains conducted output power for the EUT. In all cases, the measured peak output power should be greater and within 5% than EMI measurement.

Table 11.5: The conducted power measurement results for CDMA

CDMA BC0	Conducted Power (dBm)		
	Channel 777 (848.31MHz)	Channel 384 (836.52MHz)	Channel 1013 (824.7MHz)
SO55/RC3	23.53	23.59	23.63
SO55/RC1	23.65	23.64	23.70
SO32/RC3(FCH only)	23.56	23.57	23.70
SO32/RC3(FCH+SCH _n)	23.58	23.53	23.59
EVDO Rev.0	22.52	22.59	22.61
EVDO Rev.A	22.52	22.53	22.61
CDMA BC1	Conducted Power (dBm)		
	Channel 1175 (1908.75MHz)	Channel 600 (1880MHz)	Channel 25 (1851.25MHz)
SO55/RC3	23.52	23.30	23.92
SO55/RC1	23.46	23.40	23.87
SO32/RC3(FCH only)	23.38	23.33	23.81
SO32/RC3(FCH+SCH _n)	23.45	23.32	23.82
EVDO Rev.0	22.20	22.03	22.67
EVDO Rev.A	22.25	22.22	22.71

11.3 LTE Measurement result

Table 11.6: The conducted Power for LTE

Band 13							
Bandwidth (MHz)	RB allocation	Frequency (MHz)	Max. Target Power (dBm)	QPSK		16QAM	
	RB offset (Start RB)			Actual output power (dBm)	MPR	Actual output power (dBm)	MPR
5 MHz	1RB High (24)	784.5	24	22.86	0	21.87	1
		782	24	22.70	0	21.96	1
		779.5	24	22.91	0	22.01	1
	1RB Middle (12)	784.5	24	22.90	0	22.05	1
		782	24	22.69	0	21.73	1
		779.5	24	22.98	0	21.89	1
	1RB Low (0)	784.5	24	22.99	0	22.06	1
		782	24	22.84	0	21.85	1
		779.5	24	22.95	0	21.93	1

	12RB High (13)	784.5	24	21.94	1	20.86	2	
		782	24	21.93	1	20.90	2	
		779.5	24	22.00	1	21.98	2	
	12RB Middle (6)	784.5	24	21.92	1	20.90	2	
		782	24	21.85	1	20.78	2	
		779.5	24	21.94	1	20.85	2	
	12RB Low (0)	784.5	24	21.94	1	20.92	2	
		782	24	21.98	1	20.84	2	
		779.5	24	21.96	1	20.89	2	
	25RB (0)	784.5	24	21.82	1	20.85	2	
		782	24	21.85	1	20.86	2	
		779.5	24	21.96	1	20.92	2	
	10 MHz	1RB High (49)	782	24	22.86	0	21.97	1
		1RB Middle (24)	782	24	22.83	0	21.98	1
		1RB Low (0)	782	24	22.93	0	22.04	1
25RB High (25)		782	24	21.91	1	20.83	2	
25RB Middle (12)		782	24	21.85	1	20.82	2	
25RB Low (0)		782	24	21.97	1	20.95	2	
50RB (0)		782	24	21.90	1	20.89	2	

11.4 Wi-Fi and BT Measurement result

The output power of BT antenna is as following:

Mode	Conducted Power (dBm)		
	Channel 0 (2402MHz)	Channel 39 (2441MHz)	Channel 78 (2480MHz)
GFSK	6.71	7.44	7.42

The average conducted power for Wi-Fi is as following:

802.11b (dBm)

Channel\data rate	1Mbps	2Mbps	5.5Mbps	11Mbps
1	16.28	/	/	/
6	17.12	/	/	/
11	17.62	17.49	17.57	17.10

802.11g (dBm)

Channel\data rate	6Mbps	9Mbps	12Mbps	18Mbps	24Mbps	36Mbps	48Mbps	54Mbps
1	14.19	/	/	/	/	/	/	/
6	14.77	/	/	/	/	/	/	/
11	15.29	14.89	14.59	14.15	13.91	13.28	12.69	12.33

802.11n (dBm) - HT20 (2.4G)

Channel\data rate	MCS0	MCS1	MCS2	MCS3	MCS4	MCS5	MCS6	MCS7
1	14.15	/	/	/	/	/	/	/
6	14.75	/	/	/	/	/	/	/
11	15.31	13.58	13.10	12.74	12.16	9.84	9.66	8.54

12 Simultaneous TX SAR Considerations

12.1 Introduction

The following procedures adopted from “FCC SAR Considerations for Cell Phones with Multiple Transmitters” are applicable to handsets with built-in unlicensed transmitters such as 802.11 a/b/g and Bluetooth devices which may simultaneously transmit with the licensed transmitter. For this device, the BT and Wi-Fi can transmit simultaneous with other transmitters.

12.2 Transmit Antenna Separation Distances

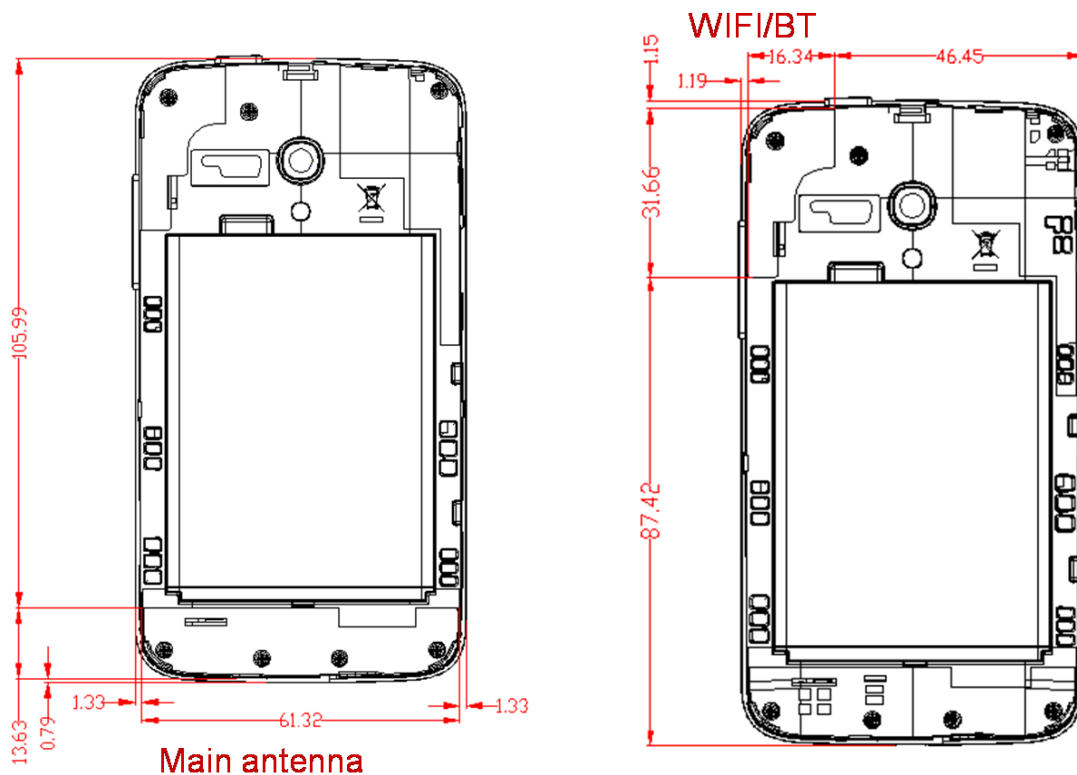

Picture 12.1 Antenna Locations

12.3 Standalone SAR Test Exclusion Considerations

Standalone 1-g head or body SAR evaluation by measurement or numerical simulation is not required when the corresponding SAR Exclusion Threshold condition, listed below, is satisfied. The 1-g SAR test exclusion threshold for 100 MHz to 6 GHz at test separation distances ≤ 50 mm are determined by:

$[(\text{max. power of channel, including tune-up tolerance, mW}) / (\text{min. test separation distance, mm})] \cdot [\sqrt{f(\text{GHz})}] \leq 3.0$ for 1-g SAR, where

- $f(\text{GHz})$ is the RF channel transmit frequency in GHz
- Power and distance are rounded to the nearest mW and mm before calculation
- The result is rounded to one decimal place for comparison

Table 12.1: Standalone SAR test exclusion considerations

Band/Mode	F(GHz)	Position	SAR test exclusion threshold (mW)	RF output power		SAR test exclusion
				dBm	mW	
Bluetooth	2.441	Head	9.60	7.44	5.55	Yes
		Body	19.20	7.44	5.55	Yes
2.4GHz WLAN 802.11 b	2.45	Head	9.58	17.62	57.81	No
		Body	19.17	17.62	57.81	No

13 Evaluation of Simultaneous

Table 13.1: The sum of reported SAR values for main antenna and WiFi

	Position	Main antenna	WiFi	Sum
Highest reported SAR value for Head	Left hand, Touch cheek	0.85	0.58	1.43
	Right hand, Touch cheek	1.31	0.28	1.59
Highest reported SAR value for Body	Rear	0.81	0.10	0.91

Table 13.2: The sum of reported SAR values for main antenna and Bluetooth

	Position	Main antenna	BT*	Sum
Highest reported SAR value for Head	Right hand, Touch cheek	1.31	0.26	1.57
Highest reported SAR value for Body	Rear	0.81	0.13	0.94

BT* - Estimated SAR for Bluetooth (see the table 13.3)

Table 13.3: Estimated SAR for Bluetooth

Position	F (GHz)	Distance (mm)	Upper limit of power *		Estimated _{1g} (W/kg)
			dBm	mW	
Head	2.441	5	8	6.31	0.26
Body	2.441	10	8	6.31	0.13

* - Maximum possible output power declared by manufacturer

When standalone SAR test exclusion applies to an antenna that transmits simultaneously with other antennas, the standalone SAR must be estimated according to following to determine simultaneous transmission SAR test exclusion:

(max. power of channel, including tune-up tolerance, mW)/(min. test separation distance, mm)]·[√f(GHz)/x] W/kg for test separation distances ≤ 50 mm;

where x = 7.5 for 1-g SAR.

When the minimum test separation distance is < 5 mm, a distance of 5 mm is applied to determine SAR test exclusion

Conclusion:

According to the above tables, the sum of reported SAR values is < 1.6W/kg. So the simultaneous transmission SAR with volume scans is not required.

14 SAR Test Result

It is determined by user manual for the distance between the EUT and the phantom bottom.

The distance is 10mm and just applied to the condition of body worn accessory.

It is performed for all SAR measurements with area scan based 1-g SAR estimation (Fast SAR). A zoom scan measurement is added when the estimated 1-g SAR is the highest measured SAR in each exposure configuration, wireless mode and frequency band combination or > 1.2W/kg.

The calculated SAR is obtained by the following formula:

$$\text{Reported SAR} = \text{Measured SAR} \times 10^{(P_{\text{Target}} - P_{\text{Measured}})/10}$$

Where P_{Target} is the power of manufacturing upper limit;

P_{Measured} is the measured power in chapter 11.

Duty Cycle

Mode	Duty Cycle
CDMA & LTE & WiFi	1:1

14.1 SAR results for Fast SAR

Table 14.1: SAR Values (CDMA BC0 - Head)

Frequency		Side	Test Position	Figure No.	Ambient Temperature: 22.2 °C		Liquid Temperature: 21.7 °C		Measured SAR(1g) (W/kg)	Reported SAR(1g) (W/kg)	Power Drift (dB)
MHz	Ch.				Conducted Power (dBm)	Max. tune-up Power (dBm)	Measured SAR(10g) (W/kg)	Reported SAR(10g) (W/kg)			
848.31	777	Left	Touch	/	23.53	24.3	0.338	0.40	0.482	0.58	0.03
836.52	384	Left	Touch	/	23.59	24.3	0.349	0.41	0.506	0.60	-0.11
824.7	1013	Left	Touch	/	23.63	24.3	0.503	0.59	0.660	0.77	0.17
848.31	777	Left	Tilt	/	23.53	24.3	0.205	0.24	0.295	0.35	-0.09
836.52	384	Left	Tilt	/	23.59	24.3	0.266	0.31	0.384	0.45	0.02
824.7	1013	Left	Tilt	/	23.63	24.3	0.323	0.38	0.464	0.54	-0.10
848.31	777	Right	Touch	/	23.53	24.3	0.475	0.57	0.714	0.85	-0.14
836.52	384	Right	Touch	/	23.59	24.3	0.426	0.50	0.633	0.75	-0.15
824.7	1013	Right	Touch	Fig.1	23.63	24.3	0.569	0.66	0.766	0.89	0.01
848.31	777	Right	Tilt	/	23.53	24.3	0.218	0.26	0.316	0.38	0.10
836.52	384	Right	Tilt	/	23.59	24.3	0.297	0.35	0.433	0.51	-0.11
824.7	1013	Right	Tilt	/	23.63	24.3	0.357	0.42	0.521	0.61	-0.10

Table 14.2: SAR Values (CDMA BC0 - Body)

Frequency		Test Position	Figure No.	Ambient Temperature: 22.2 °C		Liquid Temperature: 21.7 °C				Power Drift (dB)
MHz	Ch.			Conducted Power (dBm)	Max. tune-up Power (dBm)	Measured SAR(10g) (W/kg)	Reported SAR(10g) (W/kg)	Measured SAR(1g) (W/kg)	Reported SAR(1g) (W/kg)	
848.31	777	Front	/	23.56	24.3	0.193	0.23	0.281	0.33	-0.02
836.52	384	Front	/	23.57	24.3	0.274	0.32	0.389	0.46	-0.14
824.7	1013	Front	Fig.2	23.70	24.3	0.391	0.45	0.516	0.59	0.00
848.31	777	Rear	/	23.56	24.3	0.151	0.18	0.220	0.26	0.01
836.52	384	Rear	/	23.57	24.3	0.209	0.25	0.306	0.36	-0.15
824.7	1013	Rear	/	23.70	24.3	0.367	0.42	0.493	0.57	0.11

Note1: The distance between the EUT and the phantom bottom is 15mm.

Table 14.3: SAR Values (CDMA BC1 - Head)

Frequency		Side	Test Position	Figure No.	Ambient Temperature: 22.0 °C		Liquid Temperature: 21.6 °C				Power Drift (dB)
MHz	Ch.				Conducted Power (dBm)	Max. tune-up Power (dBm)	Measured SAR(10g) (W/kg)	Reported SAR(10g) (W/kg)	Measured SAR(1g) (W/kg)	Reported SAR(1g) (W/kg)	
1909.75	1175	Left	Touch	/	23.52	24.0	0.350	0.39	0.608	0.68	-0.18
1880	600	Left	Touch	/	23.30	24.0	0.325	0.38	0.579	0.68	-0.14
1851.25	25	Left	Touch	/	23.92	24.0	0.344	0.35	0.601	0.61	0.16
1909.75	1175	Left	Tilt	/	23.52	24.0	0.218	0.24	0.385	0.43	0.10
1880	600	Left	Tilt	/	23.30	24.0	0.164	0.19	0.281	0.33	0.10
1851.25	25	Left	Tilt	/	23.92	24.0	0.138	0.14	0.237	0.24	-0.01
1909.75	1175	Right	Touch	Fig.3	23.52	24.0	0.682	0.76	1.17	1.31	-0.05
1880	600	Right	Touch	/	23.30	24.0	0.398	0.47	0.713	0.84	0.00
1851.25	25	Right	Touch	/	23.92	24.0	0.372	0.38	0.665	0.68	0.14
1909.75	1175	Right	Tilt	/	23.52	24.0	0.223	0.25	0.422	0.47	0.05
1880	600	Right	Tilt	/	23.30	24.0	0.168	0.20	0.319	0.37	0.00
1851.25	25	Right	Tilt	/	23.92	24.0	0.146	0.15	0.277	0.28	0.05

Table 14.4: SAR Values (CDMA BC1 - Body)

Frequency		Test Position	Figure No.	Ambient Temperature: 22.0 °C		Liquid Temperature: 21.6 °C				Power Drift (dB)
MHz	Ch.			Conducted Power (dBm)	Max. tune-up Power (dBm)	Measured SAR(10g) (W/kg)	Reported SAR(10g) (W/kg)	Measured SAR(1g) (W/kg)	Reported SAR(1g) (W/kg)	
1909.75	1175	Front	Fig.4	23.38	24.0	0.341	0.39	0.547	0.63	-0.18
1880	600	Front	/	23.33	24.0	0.287	0.33	0.481	0.56	-0.08
1851.25	25	Front	/	23.81	24.0	0.272	0.28	0.459	0.48	0.03
1909.75	1175	Rear	/	23.38	24.0	0.282	0.33	0.451	0.52	0.02
1880	600	Rear	/	23.33	24.0	0.239	0.28	0.407	0.47	-0.09
1851.25	25	Rear	/	23.81	24.0	0.239	0.25	0.408	0.43	0.01

Note1: The distance between the EUT and the phantom bottom is 15mm.

Table 14.5: SAR Values (LTE Band13 - Head)

Ambient Temperature: 22.2 °C						Liquid Temperature: 21.7 °C						
Frequency		Mode	Side	Test Position	Figure No.	Conducted Power (dBm)	Max. tune-up Power (dBm)	Measured SAR(10g) (W/kg)	Reported SAR(10g) (W/kg)	Measured SAR(1g) (W/kg)	Reported SAR(1g) (W/kg)	Power Drift (dB)
MHz	Ch.											
782	23230	1RB_Low	Left	Touch	/	22.93	24.0	0.459	0.59	0.665	0.85	0.09
782	23230	1RB_Low	Left	Tilt	/	22.93	24.0	0.288	0.37	0.412	0.53	-0.02
782	23230	1RB_Low	Right	Touch	Fig.5	22.93	24.0	0.538	0.69	0.722	0.92	-0.09
782	23230	1RB_Low	Right	Tilt	/	22.93	24.0	0.331	0.42	0.480	0.61	0.15
782	23230	25RB_Low	Left	Touch	/	21.97	23.0	0.357	0.45	0.518	0.66	0.08
782	23230	25RB_Low	Left	Tilt	/	21.97	23.0	0.223	0.28	0.320	0.41	-0.02
782	23230	25RB_Low	Right	Touch	/	21.97	23.0	0.367	0.47	0.533	0.68	-0.05
782	23230	25RB_Low	Right	Tilt	/	21.97	23.0	0.261	0.33	0.379	0.48	0.03

Note1: The LTE mode is QPSK_10MHz.

Table 14.6: SAR Values (LTE Band13 - Body)

Ambient Temperature: 22.2 °C						Liquid Temperature: 21.7 °C					
Frequency		Mode	Test Position	Figure No.	Conducted Power (dBm)	Max. tune-up Power (dBm)	Measured SAR(10g) (W/kg)	Reported SAR(10g) (W/kg)	Measured SAR(1g) (W/kg)	Reported SAR(1g) (W/kg)	Power Drift (dB)
MHz	Ch.										
782	23230	1RB_Low	Front	/	22.93	24.0	0.428	0.55	0.565	0.72	0.01
782	23230	1RB_Low	Rear	Fig.6	22.93	24.0	0.472	0.60	0.634	0.81	0.03
782	23230	25RB_Low	Front	/	21.97	23.0	0.297	0.38	0.422	0.53	-0.12
782	23230	25RB_Low	Rear	/	21.97	23.0	0.348	0.44	0.499	0.63	0.10

Note1: The distance between the EUT and the phantom bottom is 15mm.

Note2: The LTE mode is QPSK_10MHz.

Table 14.7: SAR Values (Wi-Fi 802.11b - Head)

Ambient Temperature: 22.0 °C						Liquid Temperature: 21.6 °C					
Frequency		Side	Test Position	Figure No.	Conducted Power (dBm)	Max. tune-up Power (dBm)	Measured SAR(10g) (W/kg)	Reported SAR(10g) (W/kg)	Measured SAR(1g) (W/kg)	Reported SAR(1g) (W/kg)	Power Drift (dB)
MHz	Ch.										
2462	11	Left	Touch	Fig.7	17.62	18.0	0.237	0.26	0.534	0.58	-0.08
2462	11	Left	Tilt	/	17.62	18.0	0.122	0.13	0.220	0.24	0.04
2462	11	Right	Touch	/	17.62	18.0	0.135	0.15	0.259	0.28	0.09
2462	11	Right	Tilt	/	17.62	18.0	0.123	0.13	0.235	0.26	0.00

Table 14.8: SAR Values (Wi-Fi 802.11b - Body)

Ambient Temperature: 22.0 °C					Liquid Temperature: 21.6 °C					
Frequency		Test Position	Figure No.	Conducted Power (dBm)	Max. tune-up Power (dBm)	Measured SAR(10g) (W/kg)	Reported SAR(10g) (W/kg)	Measured SAR(1g) (W/kg)	Reported SAR(1g) (W/kg)	Power Drift (dB)
MHz	Ch.									
2462	11	Front	/	17.62	18.0	0.047	0.05	0.085	0.09	-0.14
2462	11	Rear	Fig.8	17.62	18.0	0.052	0.06	0.093	0.10	-0.06

Note1: The distance between the EUT and the phantom bottom is 15mm.

14.2 SAR results for Standard procedure

There is zoom scan measurement to be added for the highest measured SAR in each exposure configuration/band.

Table 14.9: SAR Values (CDMA BC0 - Head)

Ambient Temperature: 22.2 °C						Liquid Temperature: 21.7 °C					
Frequency		Side	Test Position	Figure No.	Conducted Power (dBm)	Max. tune-up Power (dBm)	Measured SAR(10g) (W/kg)	Reported SAR(10g) (W/kg)	Measured SAR(1g) (W/kg)	Reported SAR(1g) (W/kg)	Power Drift (dB)
MHz	Ch.										
824.7	1013	Right	Touch	Fig.1	23.63	24.3	0.569	0.66	0.766	0.89	0.01

Table 14.10: SAR Values (CDMA BC0 - Body)

Ambient Temperature: 22.2 °C						Liquid Temperature: 21.7 °C				
Frequency		Test Position	Figure No.	Conducted Power (dBm)	Max. tune-up Power (dBm)	Measured SAR(10g) (W/kg)	Reported SAR(10g) (W/kg)	Measured SAR(1g) (W/kg)	Reported SAR(1g) (W/kg)	Power Drift (dB)
MHz	Ch.									
824.7	1013	Front	Fig.2	23.70	24.3	0.391	0.45	0.516	0.59	0.00

Note1: The distance between the EUT and the phantom bottom is 15mm.

Table 14.11: SAR Values (CDMA BC1 - Head)

Ambient Temperature: 22.0 °C						Liquid Temperature: 21.6 °C					
Frequency		Side	Test Position	Figure No.	Conducted Power (dBm)	Max. tune-up Power (dBm)	Measured SAR(10g) (W/kg)	Reported SAR(10g) (W/kg)	Measured SAR(1g) (W/kg)	Reported SAR(1g) (W/kg)	Power Drift (dB)
MHz	Ch.										
1909.75	1175	Right	Touch	Fig.3	23.52	24.0	0.682	0.76	1.17	1.31	-0.05

Table 14.12: SAR Values (CDMA BC1 - Body)

Ambient Temperature: 22.0 °C						Liquid Temperature: 21.6 °C				
Frequency		Test Position	Figure No.	Conducted Power (dBm)	Max. tune-up Power (dBm)	Measured SAR(10g) (W/kg)	Reported SAR(10g) (W/kg)	Measured SAR(1g) (W/kg)	Reported SAR(1g) (W/kg)	Power Drift (dB)
MHz	Ch.									
1909.75	1175	Front	Fig.4	23.38	24.0	0.341	0.39	0.547	0.63	-0.18

Note1: The distance between the EUT and the phantom bottom is 15mm.

Table 14.13: SAR Values (LTE Band13 - Head)

Ambient Temperature: 22.2 °C						Liquid Temperature: 21.7 °C						
Frequency		Mode	Side	Test Position	Figure No.	Conducted Power (dBm)	Max. tune-up Power (dBm)	Measured SAR(10g) (W/kg)	Reported SAR(10g) (W/kg)	Measured SAR(1g) (W/kg)	Reported SAR(1g) (W/kg)	Power Drift (dB)
MHz	Ch.											
782	23230	1RB_Low	Right	Touch	Fig.5	22.93	24.0	0.538	0.69	0.722	0.92	-0.09

Note1: The LTE mode is QPSK_10MHz.

Table 14.14: SAR Values (LTE Band13 - Body)

Frequency		Mode	Test Position	Figure No.	Conducted Power (dBm)	Max. tune-up Power (dBm)	Measured SAR(10g) (W/kg)	Reported SAR(10g) (W/kg)	Measured SAR(1g) (W/kg)	Reported SAR(1g) (W/kg)	Power Drift (dB)
MHz	Ch.										
782	23230	1RB_Low	Rear	Fig.6	22.93	24.0	0.472	0.60	0.634	0.81	0.03

Note1: The distance between the EUT and the phantom bottom is 15mm.

Note2: The LTE mode is QPSK_10MHz.

Table 14.15: SAR Values (Wi-Fi 802.11b - Head)

Frequency		Side	Test Position	Figure No.	Conducted Power (dBm)	Max. tune-up Power (dBm)	Measured SAR(10g) (W/kg)	Reported SAR(10g) (W/kg)	Measured SAR(1g) (W/kg)	Reported SAR(1g) (W/kg)	Power Drift (dB)
MHz	Ch.										
2462	11	Left	Touch	Fig.7	17.62	18.0	0.237	0.26	0.534	0.58	-0.08

Table 14.16: SAR Values (Wi-Fi 802.11b - Body)

Frequency		Test Position	Figure No.	Conducted Power (dBm)	Max. tune-up Power (dBm)	Measured SAR(10g) (W/kg)	Reported SAR(10g) (W/kg)	Measured SAR(1g) (W/kg)	Reported SAR(1g) (W/kg)	Power Drift (dB)
MHz	Ch.									
2462	11	Rear	Fig.8	17.62	18.0	0.052	0.06	0.093	0.10	-0.06

Note1: The distance between the EUT and the phantom bottom is 15mm.

15 SAR Measurement Variability

SAR measurement variability must be assessed for each frequency band, which is determined by the SAR probe calibration point and tissue-equivalent medium used for the device measurements. When both head and body tissue-equivalent media are required for SAR measurements in a frequency band, the variability measurement procedures should be applied to the tissue medium with the highest measured SAR, using the highest measured SAR configuration for that tissue-equivalent medium.

The following procedures are applied to determine if repeated measurements are required.

- 1) Repeated measurement is not required when the original highest measured SAR is < 0.80 W/kg; steps 2) through 4) do not apply.
- 2) When the original highest measured SAR is ≥ 0.80 W/kg, repeat that measurement once.
- 3) Perform a second repeated measurement only if the ratio of largest to smallest SAR for the original and first repeated measurements is > 1.20 or when the original or repeated measurement is ≥ 1.45 W/kg (~ 10% from the 1-g SAR limit).
- 4) Perform a third repeated measurement only if the original, first or second repeated measurement is ≥ 1.5 W/kg and the ratio of largest to smallest SAR for the original, first and second repeated measurements is > 1.20 .

Table 15.1: SAR Measurement Variability for Head CDMA BC1 (1g)

Frequency		Side	Test Position	Original SAR (W/kg)	First Repeated SAR (W/kg)	The Ratio	Second Repeated SAR (W/kg)
MHz	Ch.						
1909.75	1175	Left	Touch	1.17	1.16	1.01	/

16 Measurement Uncertainty

16.1 Measurement Uncertainty for Normal SAR Tests (300MHz~3GHz)

No.	Error Description	Type	Uncertainty value	Probably Distribution	Div.	(Ci) 1g	(Ci) 10g	Std. Unc. (1g)	Std. Unc. (10g)	Degree of freedom
Measurement system										
1	Probe calibration	B	5.5	N	1	1	1	5.5	5.5	∞
2	Isotropy	B	4.7	R	$\sqrt{3}$	0.7	0.7	1.9	1.9	∞
3	Boundary effect	B	1.0	R	$\sqrt{3}$	1	1	0.6	0.6	∞
4	Linearity	B	4.7	R	$\sqrt{3}$	1	1	2.7	2.7	∞
5	Detection limit	B	1.0	R	$\sqrt{3}$	1	1	0.6	0.6	∞
6	Readout electronics	B	0.3	R	$\sqrt{3}$	1	1	0.3	0.3	∞
7	Response time	B	0.8	R	$\sqrt{3}$	1	1	0.5	0.5	∞
8	Integration time	B	2.6	R	$\sqrt{3}$	1	1	1.5	1.5	∞
9	RF ambient conditions-noise	B	0	R	$\sqrt{3}$	1	1	0	0	∞
10	RF ambient conditions-reflection	B	0	R	$\sqrt{3}$	1	1	0	0	∞
11	Probe positioned mech. restrictions	B	0.4	R	$\sqrt{3}$	1	1	0.2	0.2	∞
12	Probe positioning with respect to phantom shell	B	2.9	R	$\sqrt{3}$	1	1	1.7	1.7	∞
13	Post-processing	B	1.0	R	$\sqrt{3}$	1	1	0.6	0.6	∞
Test sample related										
14	Test sample positioning	A	3.3	N	1	1	1	3.3	3.3	71
15	Device holder uncertainty	A	3.4	N	1	1	1	3.4	3.4	5
16	Drift of output power	B	5.0	R	$\sqrt{3}$	1	1	2.9	2.9	∞
Phantom and set-up										
17	Phantom uncertainty	B	4.0	R	$\sqrt{3}$	1	1	2.3	2.3	∞
18	Liquid conductivity (target)	B	5.0	R	$\sqrt{3}$	0.64	0.43	1.8	1.2	∞
19	Liquid conductivity (meas.)	A	2.06	N	1	0.64	0.43	1.32	0.89	43
20	Liquid permittivity (target)	B	5.0	R	$\sqrt{3}$	0.6	0.49	1.7	1.4	∞
21	Liquid permittivity (meas.)	A	1.6	N	1	0.6	0.49	1.0	0.8	521

Combined standard uncertainty	$u_c = \sqrt{\sum_{i=1}^{21} c_i^2 u_i^2}$						9.25	9.12	257
Expanded uncertainty (confidence interval of 95 %)	$u_e = 2u_c$						18.5	18.2	

16.2 Measurement Uncertainty for Normal SAR Tests (3~6GHz)

No.	Error Description	Type	Uncertainty value	Probably Distribution	Div.	(Ci) 1g	(Ci) 10g	Std. Unc. (1g)	Std. Unc. (10g)	Degree of freedom
Measurement system										
1	Probe calibration	B	6.5	N	1	1	1	6.5	6.5	∞
2	Isotropy	B	4.7	R	$\sqrt{3}$	0.7	0.7	1.9	1.9	∞
3	Boundary effect	B	2.0	R	$\sqrt{3}$	1	1	1.2	1.2	∞
4	Linearity	B	4.7	R	$\sqrt{3}$	1	1	2.7	2.7	∞
5	Detection limit	B	1.0	R	$\sqrt{3}$	1	1	0.6	0.6	∞
6	Readout electronics	B	0.3	R	$\sqrt{3}$	1	1	0.3	0.3	∞
7	Response time	B	0.8	R	$\sqrt{3}$	1	1	0.5	0.5	∞
8	Integration time	B	2.6	R	$\sqrt{3}$	1	1	1.5	1.5	∞
9	RF ambient conditions-noise	B	0	R	$\sqrt{3}$	1	1	0	0	∞
10	RF ambient conditions-reflection	B	0	R	$\sqrt{3}$	1	1	0	0	∞
11	Probe positioned mech. restrictions	B	0.8	R	$\sqrt{3}$	1	1	0.5	0.5	∞
12	Probe positioning with respect to phantom shell	B	6.7	R	$\sqrt{3}$	1	1	3.9	3.9	∞
13	Post-processing	B	4.0	R	$\sqrt{3}$	1	1	2.3	2.3	∞
Test sample related										
14	Test sample positioning	A	3.3	N	1	1	1	3.3	3.3	71
15	Device holder uncertainty	A	3.4	N	1	1	1	3.4	3.4	5
16	Drift of output power	B	5.0	R	$\sqrt{3}$	1	1	2.9	2.9	∞
Phantom and set-up										
17	Phantom uncertainty	B	4.0	R	$\sqrt{3}$	1	1	2.3	2.3	∞
18	Liquid conductivity (target)	B	5.0	R	$\sqrt{3}$	0.64	0.43	1.8	1.2	∞
19	Liquid conductivity (meas.)	A	2.06	N	1	0.64	0.43	1.32	0.89	43

20	Liquid permittivity (target)	B	5.0	R	$\sqrt{3}$	0.6	0.49	1.7	1.4	∞
21	Liquid permittivity (meas.)	A	1.6	N	1	0.6	0.49	1.0	0.8	521
Combined standard uncertainty		$u_c = \sqrt{\sum_{i=1}^{21} c_i^2 u_i^2}$						10.8	10.7	257
Expanded uncertainty (confidence interval of 95 %)		$u_e = 2u_c$						21.6	21.4	

16.3 Measurement Uncertainty for Fast SAR Tests (300MHz~3GHz)

No.	Error Description	Type	Uncertainty value	Probably Distribution	Div.	(Ci) 1g	(Ci) 10g	Std. Unc. (1g)	Std. Unc. (10g)	Degree of freedom
Measurement system										
1	Probe calibration	B	5.5	N	1	1	1	5.5	5.5	∞
2	Isotropy	B	4.7	R	$\sqrt{3}$	0.7	0.7	1.9	1.9	∞
3	Boundary effect	B	1.0	R	$\sqrt{3}$	1	1	0.6	0.6	∞
4	Linearity	B	4.7	R	$\sqrt{3}$	1	1	2.7	2.7	∞
5	Detection limit	B	1.0	R	$\sqrt{3}$	1	1	0.6	0.6	∞
6	Readout electronics	B	0.3	R	$\sqrt{3}$	1	1	0.3	0.3	∞
7	Response time	B	0.8	R	$\sqrt{3}$	1	1	0.5	0.5	∞
8	Integration time	B	2.6	R	$\sqrt{3}$	1	1	1.5	1.5	∞
9	RF ambient conditions-noise	B	0	R	$\sqrt{3}$	1	1	0	0	∞
10	RF ambient conditions-reflection	B	0	R	$\sqrt{3}$	1	1	0	0	∞
11	Probe positioned mech. Restrictions	B	0.4	R	$\sqrt{3}$	1	1	0.2	0.2	∞
12	Probe positioning with respect to phantom shell	B	2.9	R	$\sqrt{3}$	1	1	1.7	1.7	∞
13	Post-processing	B	1.0	R	$\sqrt{3}$	1	1	0.6	0.6	∞
14	Fast SAR z-Approximation	B	7.0	R	$\sqrt{3}$	1	1	4.0	4.0	∞
Test sample related										
15	Test sample positioning	A	3.3	N	1	1	1	3.3	3.3	71
16	Device holder uncertainty	A	3.4	N	1	1	1	3.4	3.4	5
17	Drift of output power	B	5.0	R	$\sqrt{3}$	1	1	2.9	2.9	∞

Phantom and set-up										
18	Phantom uncertainty	B	4.0	R	$\sqrt{3}$	1	1	2.3	2.3	∞
19	Liquid conductivity (target)	B	5.0	R	$\sqrt{3}$	0.64	0.43	1.8	1.2	∞
20	Liquid conductivity (meas.)	A	2.06	N	1	0.64	0.43	1.32	0.89	43
21	Liquid permittivity (target)	B	5.0	R	$\sqrt{3}$	0.6	0.49	1.7	1.4	∞
22	Liquid permittivity (meas.)	A	1.6	N	1	0.6	0.49	1.0	0.8	521
Combined standard uncertainty		$u_c = \sqrt{\sum_{i=1}^{22} c_i^2 u_i^2}$						10.1	9.95	257
Expanded uncertainty (confidence interval of 95 %)		$u_e = 2u_c$						20.2	19.9	

16.4 Measurement Uncertainty for Fast SAR Tests (3~6GHz)

No.	Error Description	Type	Uncertainty value	Probably Distribution	Div.	(Ci) 1g	(Ci) 10g	Std. Unc. (1g)	Std. Unc. (10g)	Degree of freedom
Measurement system										
1	Probe calibration	B	6.5	N	1	1	1	6.5	6.5	∞
2	Isotropy	B	4.7	R	$\sqrt{3}$	0.7	0.7	1.9	1.9	∞
3	Boundary effect	B	2.0	R	$\sqrt{3}$	1	1	1.2	1.2	∞
4	Linearity	B	4.7	R	$\sqrt{3}$	1	1	2.7	2.7	∞
5	Detection limit	B	1.0	R	$\sqrt{3}$	1	1	0.6	0.6	∞
6	Readout electronics	B	0.3	R	$\sqrt{3}$	1	1	0.3	0.3	∞
7	Response time	B	0.8	R	$\sqrt{3}$	1	1	0.5	0.5	∞
8	Integration time	B	2.6	R	$\sqrt{3}$	1	1	1.5	1.5	∞
9	RF ambient conditions-noise	B	0	R	$\sqrt{3}$	1	1	0	0	∞
10	RF ambient conditions-reflection	B	0	R	$\sqrt{3}$	1	1	0	0	∞
11	Probe positioned mech. Restrictions	B	0.8	R	$\sqrt{3}$	1	1	0.5	0.5	∞
12	Probe positioning with respect to phantom shell	B	6.7	R	$\sqrt{3}$	1	1	3.9	3.9	∞
13	Post-processing	B	1.0	R	$\sqrt{3}$	1	1	0.6	0.6	∞
14	Fast SAR z-Approximation	B	14.0	R	$\sqrt{3}$	1	1	8.1	8.1	∞
Test sample related										

15	Test sample positioning	A	3.3	N	1	1	1	3.3	3.3	71
16	Device holder uncertainty	A	3.4	N	1	1	1	3.4	3.4	5
17	Drift of output power	B	5.0	R	$\sqrt{3}$	1	1	2.9	2.9	∞
Phantom and set-up										
18	Phantom uncertainty	B	4.0	R	$\sqrt{3}$	1	1	2.3	2.3	∞
19	Liquid conductivity (target)	B	5.0	R	$\sqrt{3}$	0.64	0.43	1.8	1.2	∞
20	Liquid conductivity (meas.)	A	2.06	N	1	0.64	0.43	1.32	0.89	43
21	Liquid permittivity (target)	B	5.0	R	$\sqrt{3}$	0.6	0.49	1.7	1.4	∞
22	Liquid permittivity (meas.)	A	1.6	N	1	0.6	0.49	1.0	0.8	521
Combined standard uncertainty		$u_c = \sqrt{\sum_{i=1}^{22} c_i^2 u_i^2}$						13.3	13.2	257
Expanded uncertainty (confidence interval of 95 %)		$u_e = 2u_c$						26.6	26.4	

17 MAIN TEST INSTRUMENTS

Table 17.1: List of Main Instruments

No.	Name	Type	Serial Number	Calibration Date	Valid Period
01	Network analyzer	E5071C	MY46110673	February 15, 2014	One year
02	Power meter	NRVD	102196	March 14, 2014	One year
03	Power sensor	NRV-Z5	100596		
04	Signal Generator	E4438C	MY49071430	February 08, 2014	One Year
05	Amplifier	60S1G4	0331848	No Calibration Requested	
06	BTS	E5515C	MY50263375	January 30, 2014	One year
07	BTS	CMW500	129942	March 11, 2014	One year
08	E-field Probe	SPEAG EX3DV4	3846	September 24, 2014	One year
09	DAE	SPEAG DAE4	777	September 17, 2014	One year
10	Dipole Validation Kit	SPEAG D750V3	1017	August 28, 2014	One year
11	Dipole Validation Kit	SPEAG D835V2	4d069	August 28, 2014	One year
12	Dipole Validation Kit	SPEAG D1900V2	5d101	July 23, 2014	One year
13	Dipole Validation Kit	SPEAG D2450V2	853	July 24, 2014	One year

END OF REPORT BODY

ANNEX A Graph Results

CDMA BC0 Head Right Cheek Low

Date: 2014-12-24

Electronics: DAE4 Sn777

Medium: Head 850 MHz

Medium parameters used: $f = 825$ MHz; $\sigma = 0.925$ S/m; $\epsilon_r = 42.836$; $\rho = 1000$ kg/m³

Ambient Temperature: 22.2°C Liquid Temperature: 21.7°C

Communication System: CDMA BC0 Frequency: 824.7 MHz Duty Cycle: 1:1

Probe: EX3DV4 - SN3846 ConvF(9.18, 9.18, 9.18)

Cheek Low/Area Scan (61x101x1): Interpolated grid: dx=1.000 mm, dy=1.000 mm
Maximum value of SAR (interpolated) = 0.911 W/kg

Cheek Low/Zoom Scan (7x7x7)/Cube 0: Measurement grid: dx=5mm, dy=5mm, dz=5mm

Reference Value = 13.25 V/m; Power Drift = 0.01 dB

Peak SAR (extrapolated) = 1.03 W/kg

SAR(1 g) = 0.766 W/kg; SAR(10 g) = 0.569 W/kg

Maximum value of SAR (measured) = 0.897 W/kg

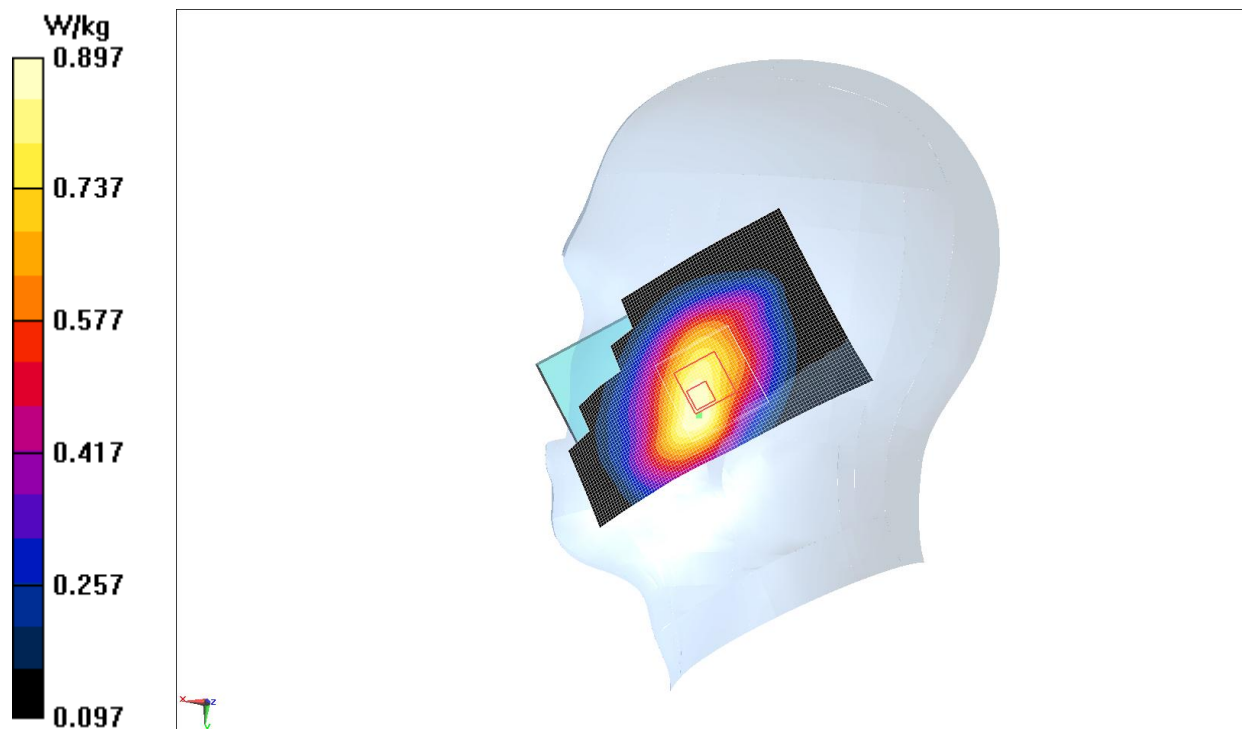

Fig.1 CDMA BC0

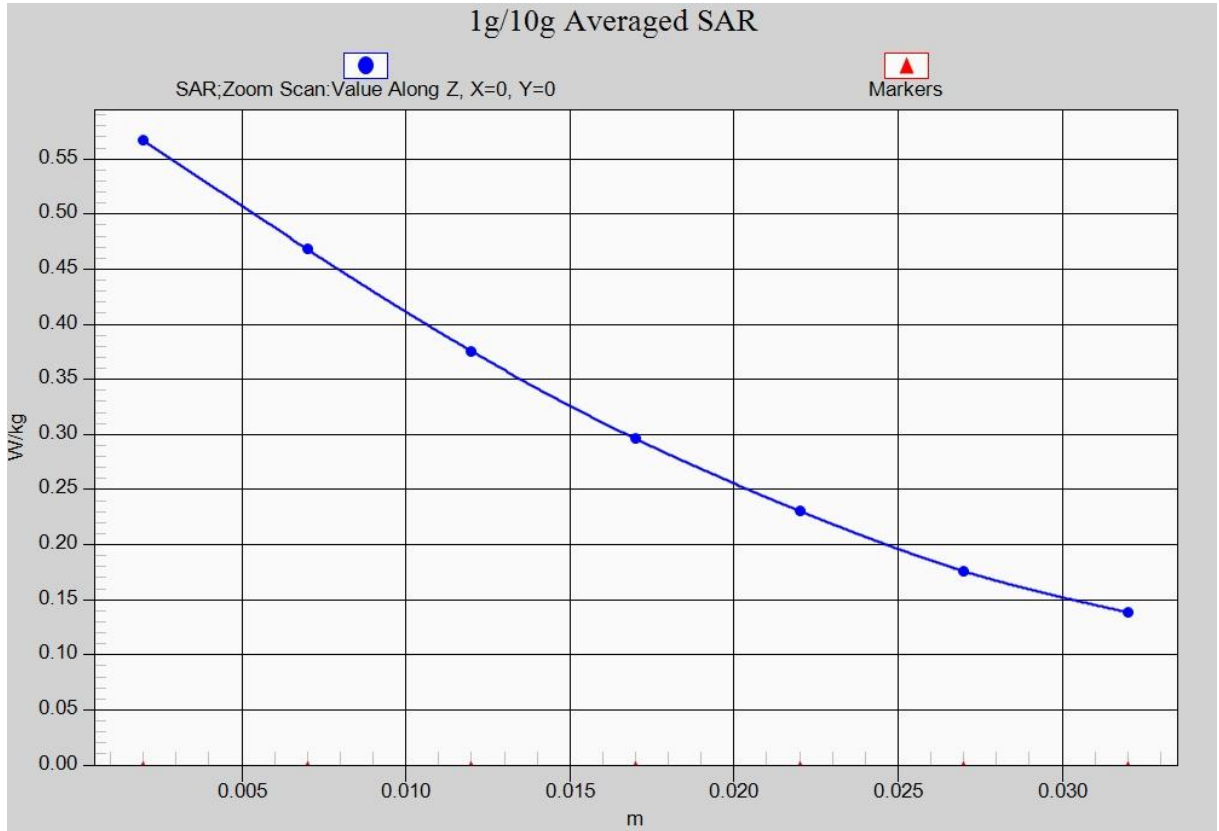

Fig. 1-1 Z-Scan at power reference point (CDMA BC0)

CDMA BC0 Body Front Low

Date: 2014-12-24

Electronics: DAE4 Sn777

Medium: Body 850 MHz

Medium parameters used: $f = 825$ MHz; $\sigma = 0.954$ S/m; $\epsilon_r = 54.936$; $\rho = 1000$ kg/m³

Ambient Temperature: 22.2°C Liquid Temperature: 21.7°C

Communication System: CDMA BC0 Frequency: 824.7 MHz Duty Cycle: 1:1

Probe: EX3DV4 - SN3846 ConvF(9.09, 9.09, 9.09)

Front Low/Area Scan (101x61x1): Interpolated grid: dx=1.000 mm, dy=1.000 mm

Maximum value of SAR (interpolated) = 0.561 W/kg

Front Low/Zoom Scan (7x7x7)/Cube 0: Measurement grid: dx=5mm, dy=5mm, dz=5mm

Reference Value = 23.97 V/m; Power Drift = 0.00 dB

Peak SAR (extrapolated) = 0.656 W/kg

SAR(1 g) = 0.516 W/kg; SAR(10 g) = 0.391 W/kg

Maximum value of SAR (measured) = 0.567 W/kg

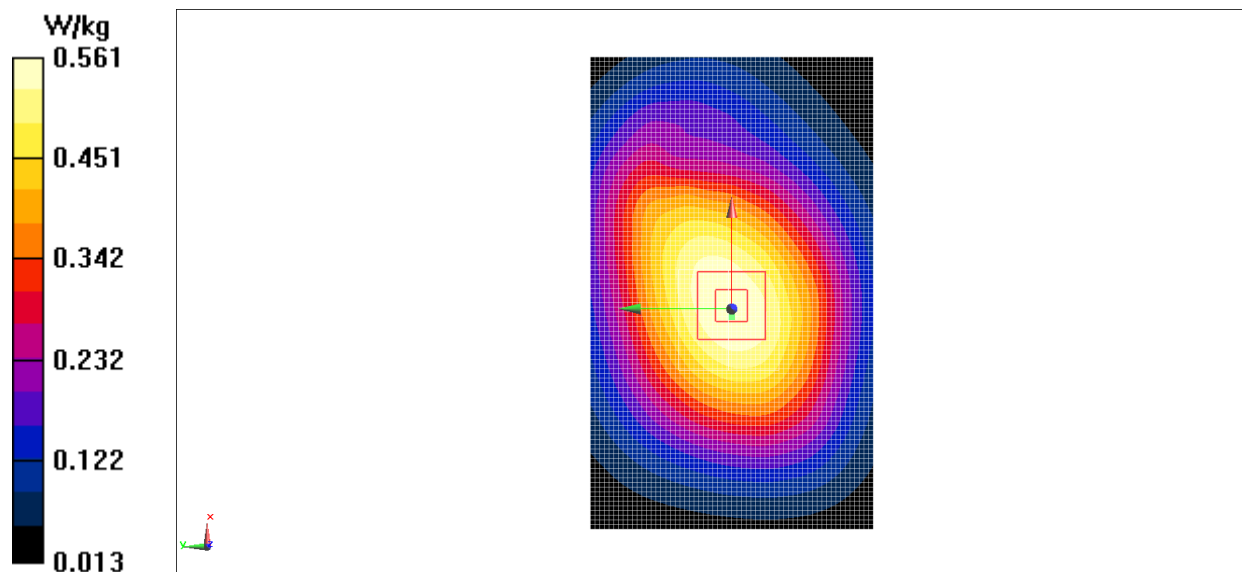

Fig.2 CDMA BC0

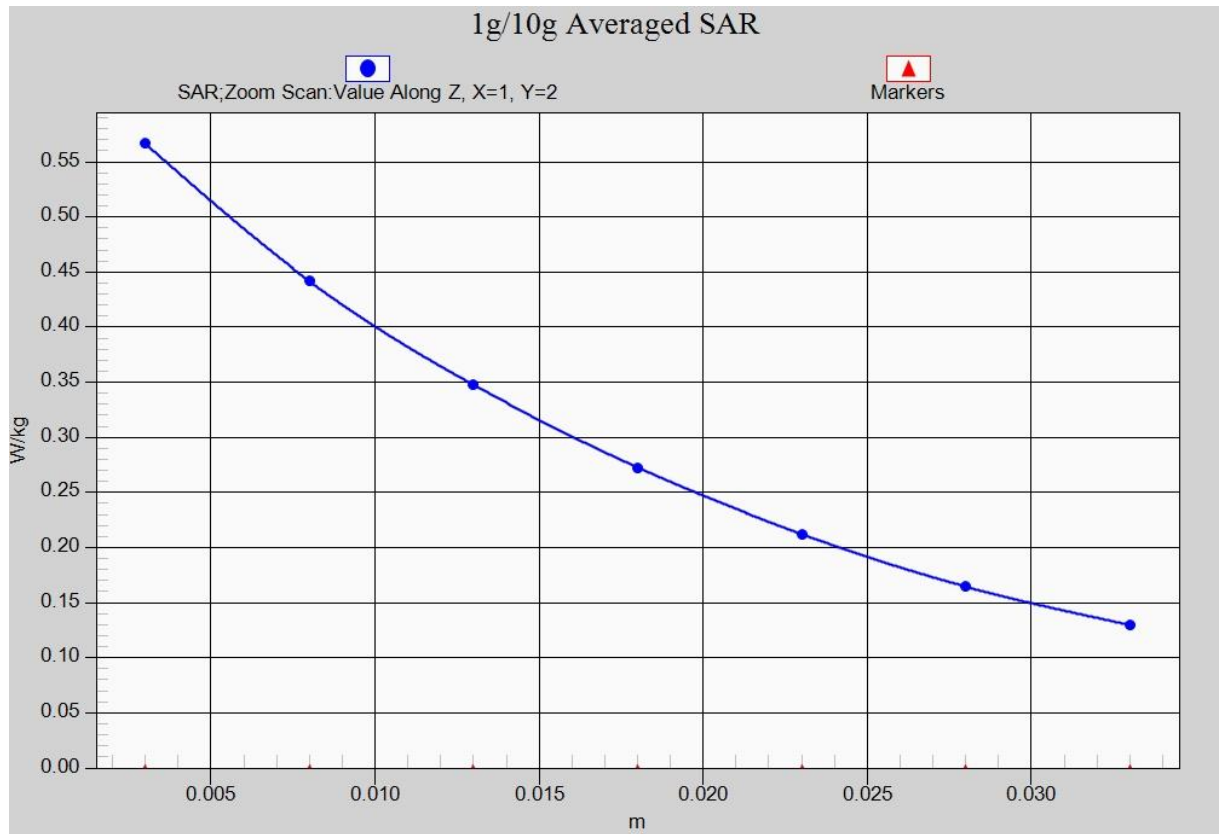

Fig. 2-1 Z-Scan at power reference point (CDMA BC0)

CDMA BC1 Head Right Cheek High

Date: 2014-12-25

Electronics: DAE4 Sn777

Medium: Head 1900 MHz

Medium parameters used (interpolated): $f = 1908.75$ MHz; $\sigma = 1.397$ S/m; $\epsilon_r = 40.141$; $\rho = 1000$ kg/m³

Ambient Temperature: 22.0°C Liquid Temperature: 21.6°C

Communication System: CDMA BC1 Frequency: 1908.75 MHz Duty Cycle: 1:1

Probe: EX3DV4 - SN3846 ConvF(7.26, 7.26, 7.26)

Cheek High/Area Scan (61x101x1): Interpolated grid: dx=1.000 mm, dy=1.000 mm

Maximum value of SAR (interpolated) = 1.33 W/kg

Cheek High/Zoom Scan (7x7x7)/Cube 0: Measurement grid: dx=5mm, dy=5mm, dz=5mm

Reference Value = 14.21 V/m; Power Drift = -0.05 dB

Peak SAR (extrapolated) = 1.79 W/kg

SAR(1 g) = 1.17 W/kg; SAR(10 g) = 0.682 W/kg

Maximum value of SAR (measured) = 1.27 W/kg

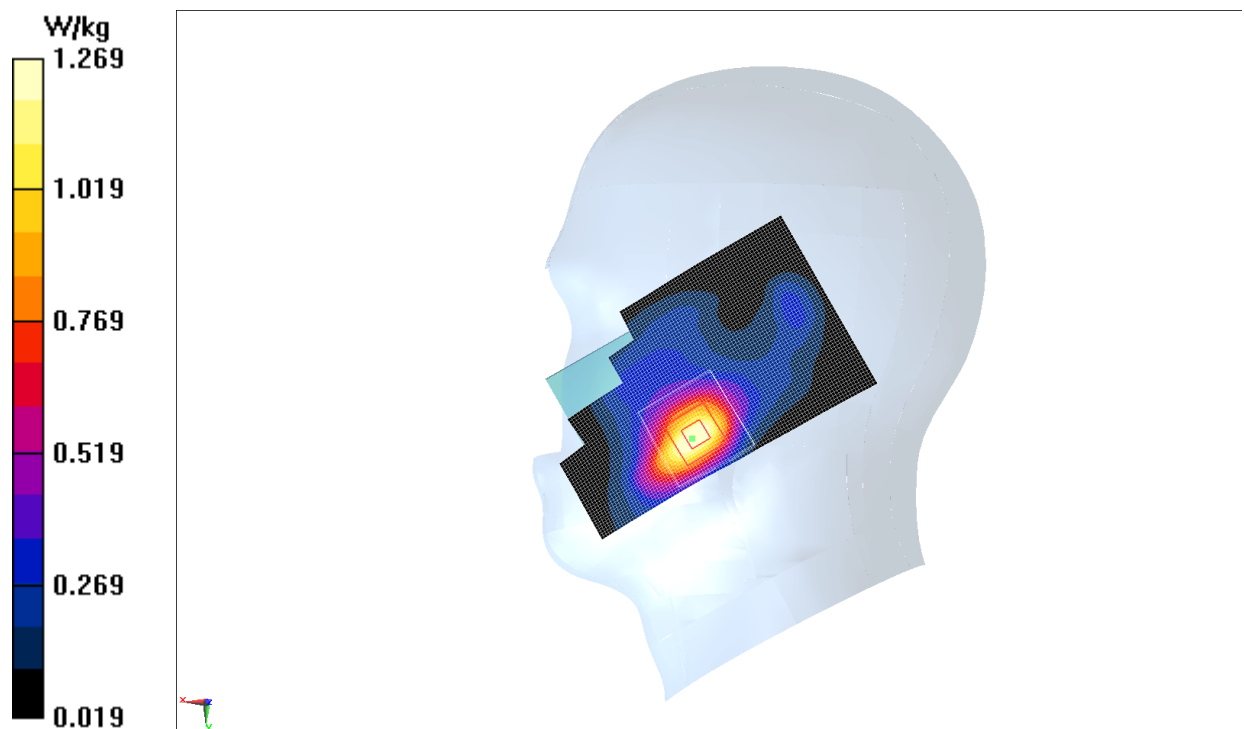

Fig.3 CDMA BC1

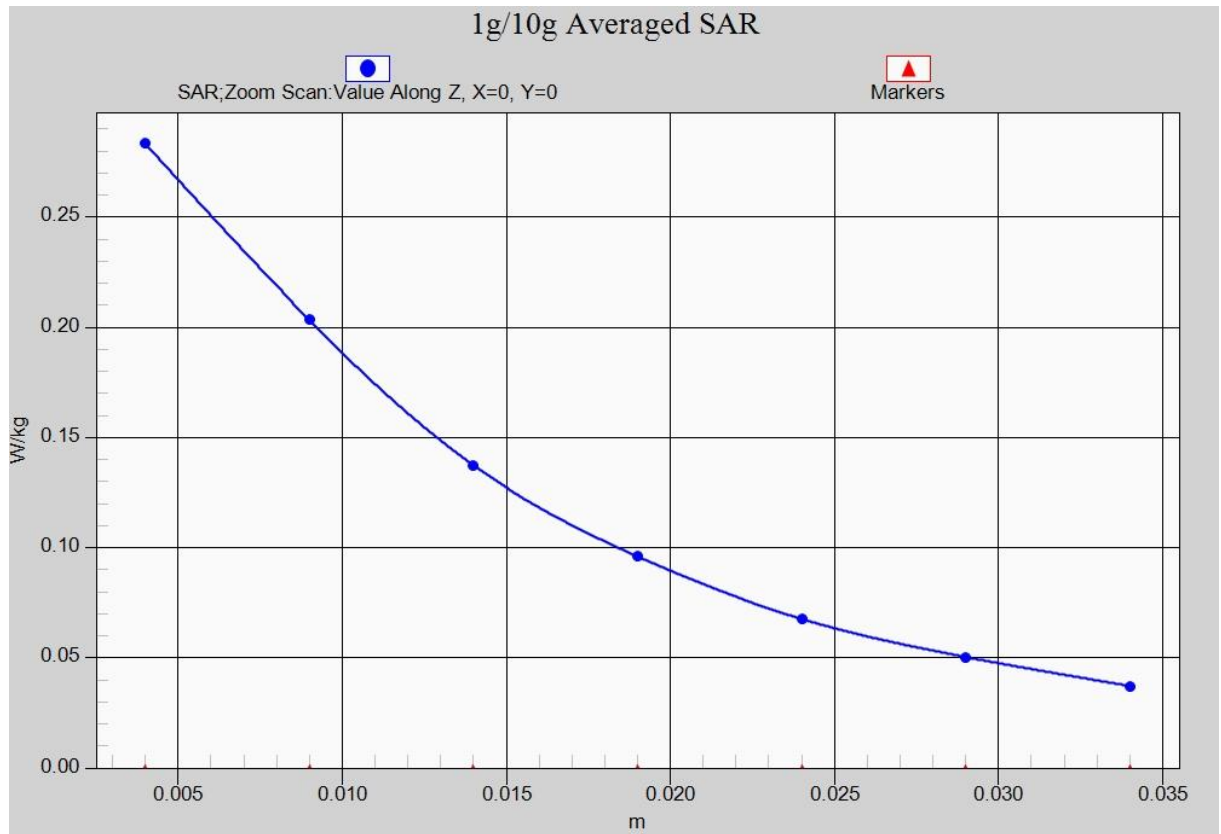

Fig. 3-1 Z-Scan at power reference point (CDMA BC1)

CDMA BC1 Body Front High

Date: 2014-12-25

Electronics: DAE4 Sn777

Medium: Body 1900 MHz

Medium parameters used (interpolated): $f = 1908.75$ MHz; $\sigma = 1.518$ S/m; $\epsilon_r = 54.039$; $\rho = 1000$ kg/m³

Ambient Temperature: 22.0°C Liquid Temperature: 21.6°C

Communication System: CDMA BC1 Frequency: 1908.75 MHz Duty Cycle: 1:1

Probe: EX3DV4 - SN3846 ConvF(7.15, 7.15, 7.15)

Front High/Area Scan (101x61x1): Interpolated grid: dx=1.000 mm, dy=1.000 mm

Maximum value of SAR (interpolated) = 0.650 W/kg

Front High/Zoom Scan (7x7x7)/Cube 0: Measurement grid: dx=5mm, dy=5mm, dz=5mm

Reference Value = 9.910 V/m; Power Drift = -0.18 dB

Peak SAR (extrapolated) = 0.841 W/kg

SAR(1 g) = 0.547 W/kg; SAR(10 g) = 0.341 W/kg

Maximum value of SAR (measured) = 0.646 W/kg

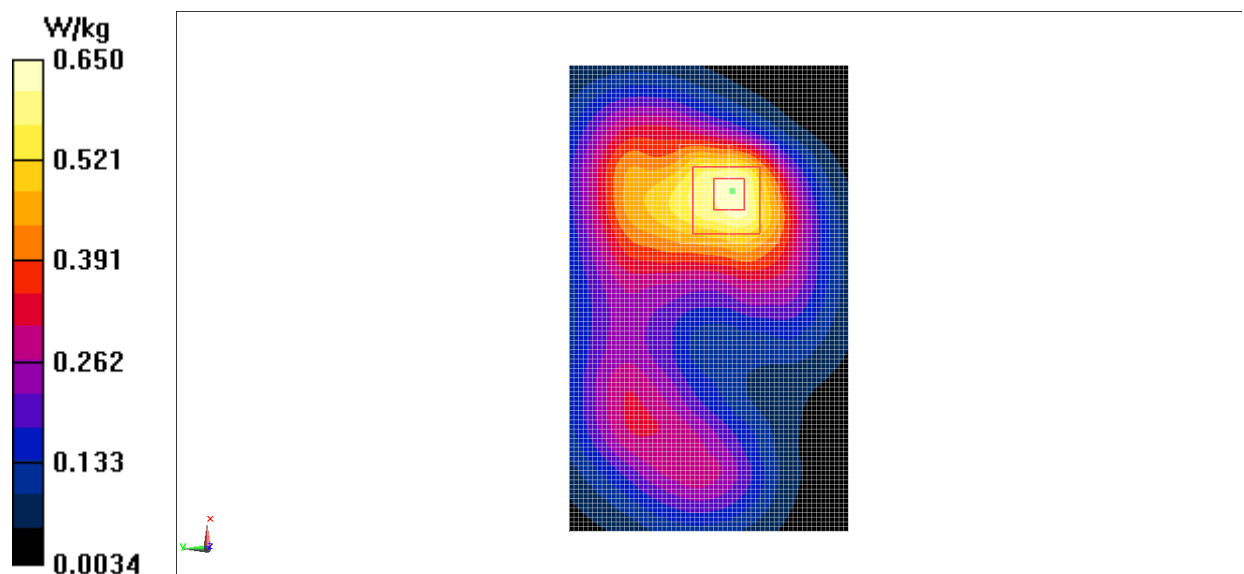

Fig.4 CDMA BC1

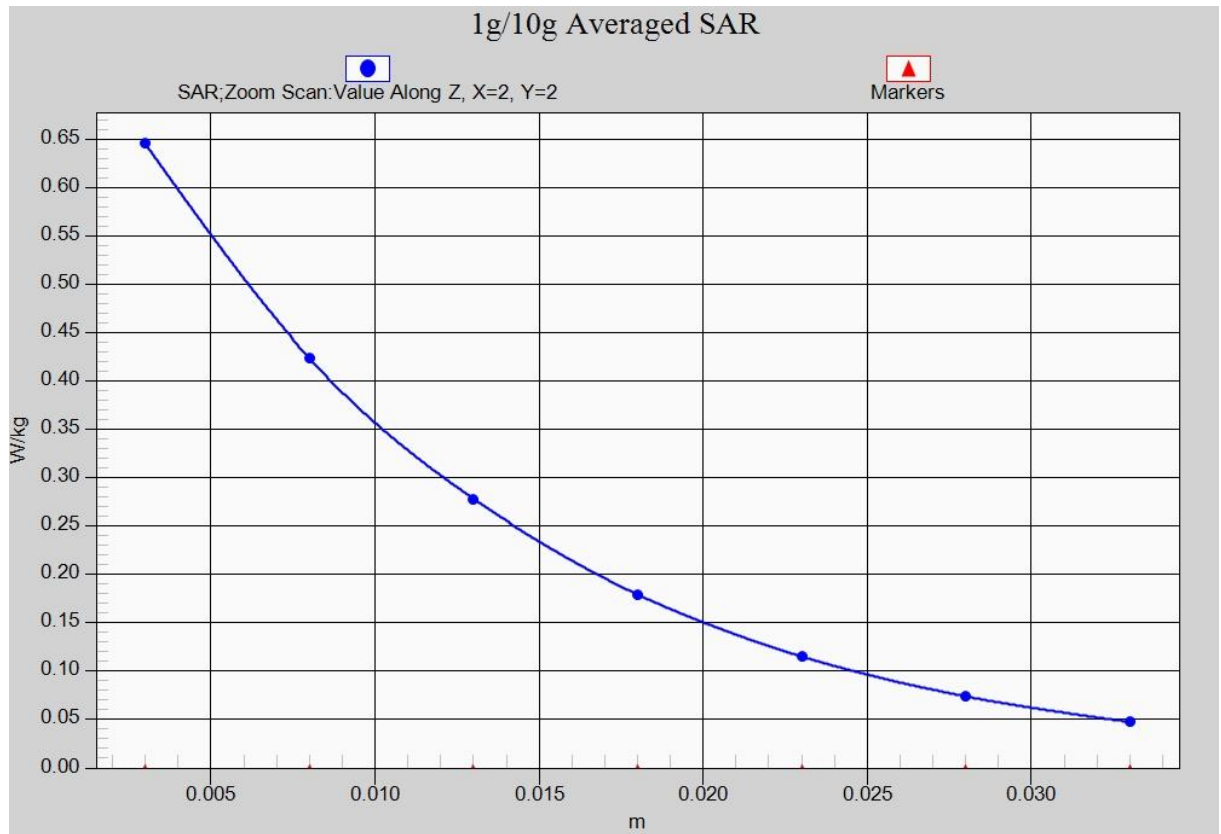

Fig.4-1 Z-Scan at power reference point (CDMA BC1)

LTE Band 13 Right Cheek Middle with QPSK_10M_1RB_Low

Date: 2014-12-23

Electronics: DAE4 Sn777

Medium: Head 750 MHz

Medium parameters used (interpolated): $f = 782$ MHz; $\sigma = 0.905$ mho/m; $\epsilon_r = 42.985$; $\rho = 1000$ kg/m³

Ambient Temperature: 22.2°C Liquid Temperature: 21.7°C

Communication System: LTE Band13 Frequency: 782 MHz Duty Cycle: 1:1

Probe: EX3DV4 - SN3846 ConvF(9.53, 9.53, 9.53)

Right Cheek/Area Scan (61x101x1): Interpolated grid: dx=1.000 mm, dy=1.000 mm

Maximum value of SAR (interpolated) = 0.798 W/kg

Right Cheek/Zoom Scan (7x7x7)/Cube 0: Measurement grid: dx=5mm, dy=5mm, dz=5mm

Reference Value = 13.88 V/m; Power Drift = -0.09 dB

Peak SAR (extrapolated) = 0.963 W/kg

SAR(1 g) = 0.722 W/kg; SAR(10 g) = 0.538 W/kg

Maximum value of SAR (measured) = 0.771 W/kg

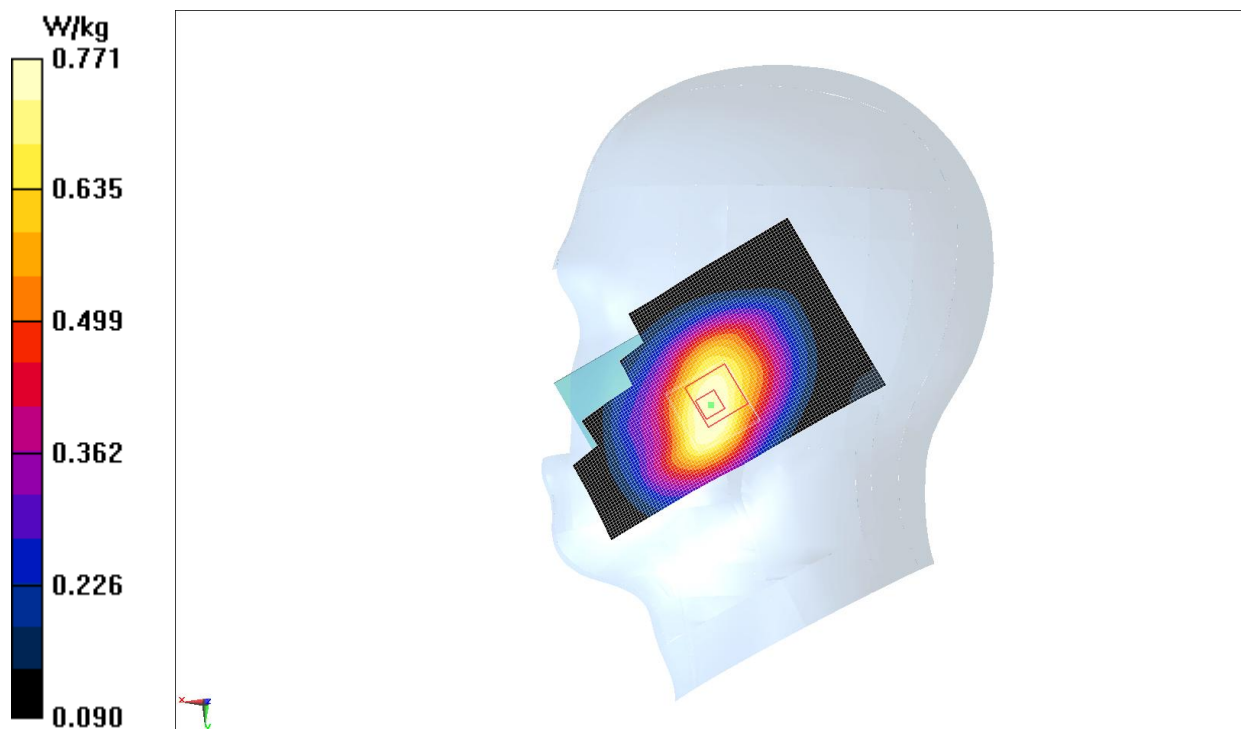

Fig.5 LTE Band 13

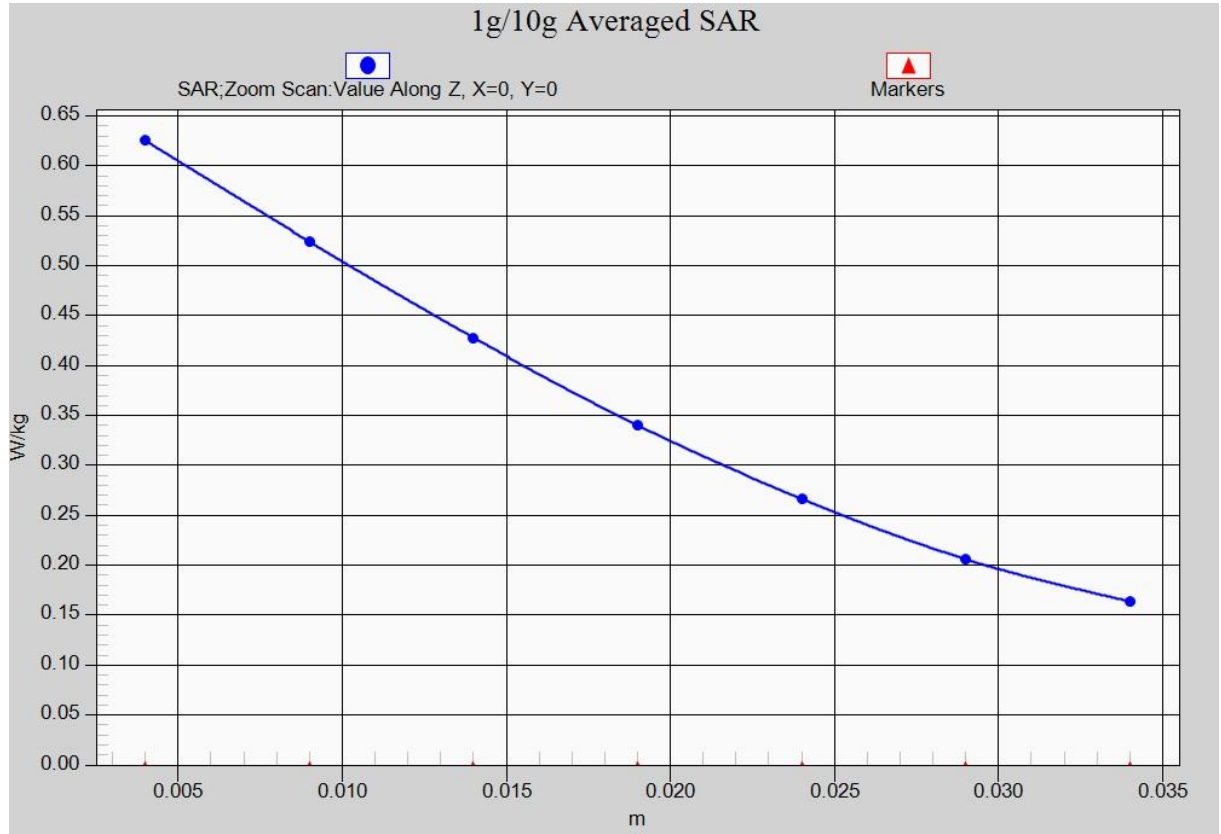

Fig. 5-1 Z-Scan at power reference point (LTE Band13)

LTE Band 13 Body Rear Middle with QPSK_10M_1RB_Low

Date: 2014-12-23

Electronics: DAE4 Sn777

Medium: Body 750 MHz

Medium parameters used (interpolated): $f = 782$ MHz; $\sigma = 0.955$ mho/m; $\epsilon_r = 55.265$; $\rho = 1000$ kg/m³

Ambient Temperature: 22.2°C Liquid Temperature: 21.7°C

Communication System: LTE Band13 Frequency: 782 MHz Duty Cycle: 1:1

Probe: EX3DV4 - SN3846 ConvF(9.18, 9.18, 9.18)

Rear Low/Area Scan (101x61x1): Interpolated grid: dx=1.000 mm, dy=1.000 mm

Maximum value of SAR (interpolated) = 0.707 W/kg

Rear Low/Zoom Scan (7x7x7)/Cube 0: Measurement grid: dx=5mm, dy=5mm, dz=5mm

Reference Value = 27.15 V/m; Power Drift = 0.03 dB

Peak SAR (extrapolated) = 0.826 W/kg

SAR(1 g) = 0.634 W/kg; SAR(10 g) = 0.472 W/kg

Maximum value of SAR (measured) = 0.708 W/kg

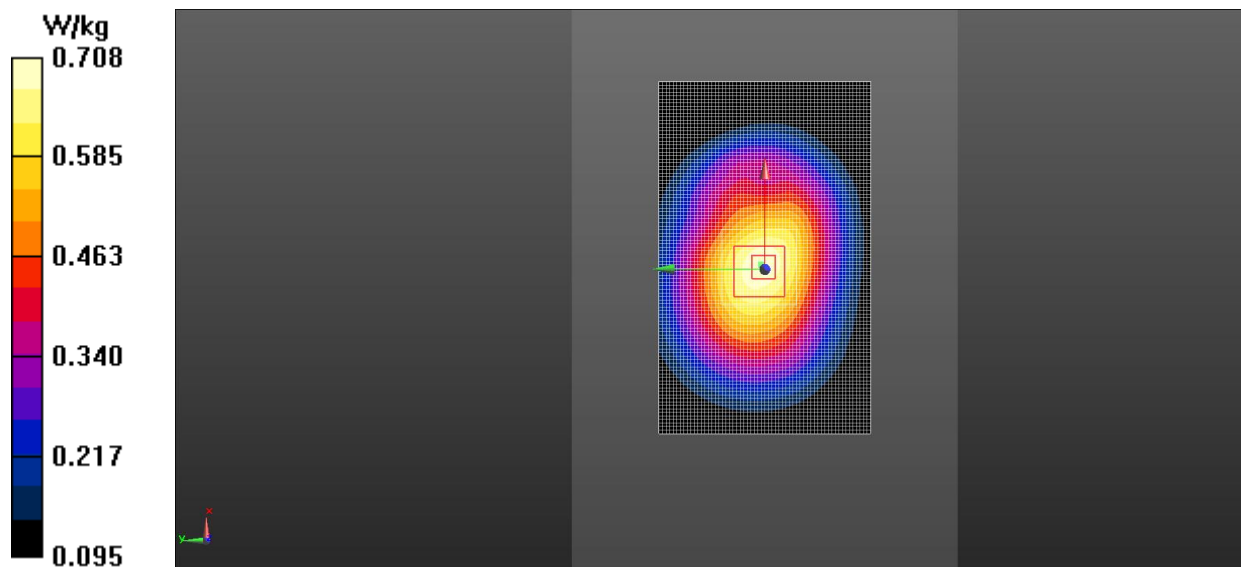

Fig.6 LTE Band 13

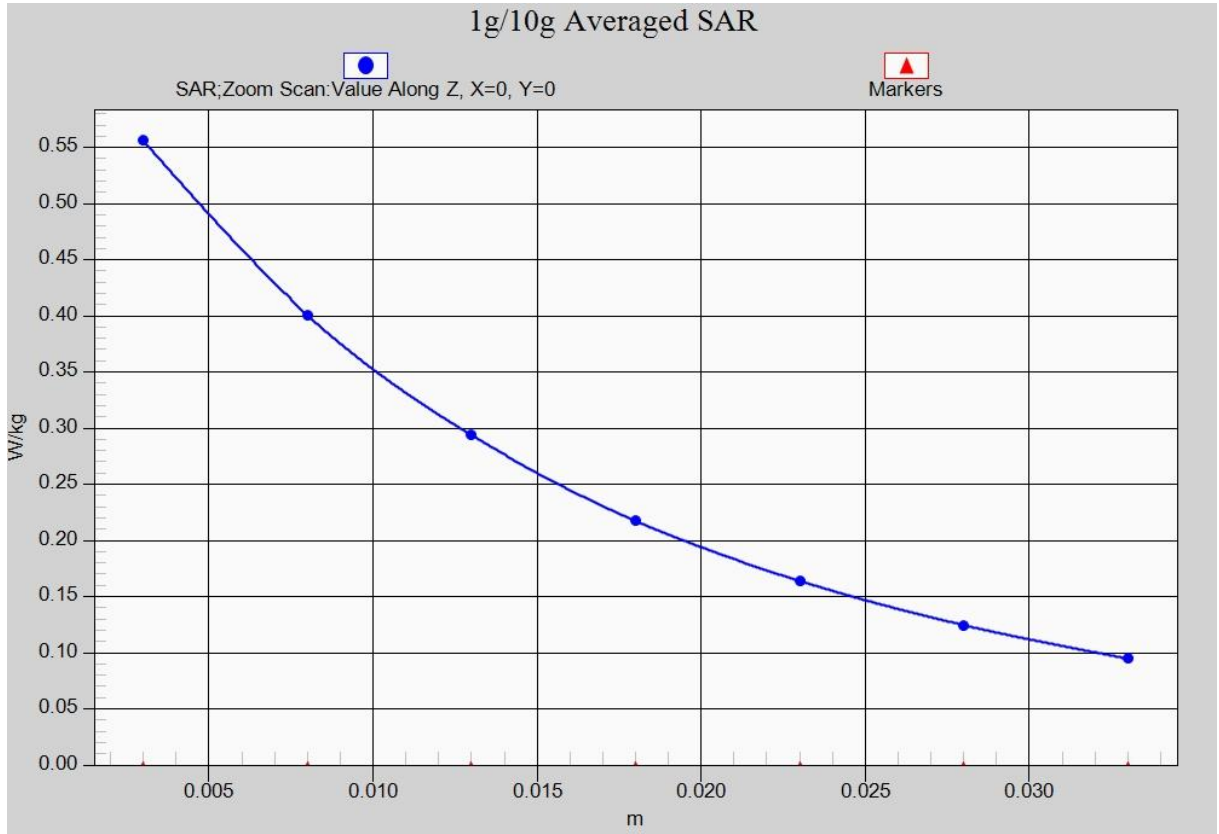

Fig. 6-1 Z-Scan at power reference point (LTE Band13)

Wifi 802.11b Left Cheek Channel 11

Date: 2014-12-26

Electronics: DAE4 Sn777

Medium: Head 2450 MHz

Medium parameters used (interpolated): $f = 2462$ MHz; $\sigma = 1.85$ S/m; $\epsilon_r = 40.155$; $\rho = 1000$ kg/m³

Ambient Temperature: 22.0°C Liquid Temperature: 21.6°C

Communication System: WLAN 2450 Frequency: 2462 MHz Duty Cycle: 1:1

Probe: EX3DV4 - SN3846 ConvF(6.56, 6.56, 6.56)

Cheek High/Area Scan (71x121x1): Interpolated grid: dx=1.000 mm, dy=1.000 mm

Maximum value of SAR (interpolated) = 0.695 W/kg

Cheek High/Zoom Scan (7x7x7)/Cube 0: Measurement grid: dx=5mm, dy=5mm, dz=5mm

Reference Value = 9.594 V/m; Power Drift = -0.08 dB

Peak SAR (extrapolated) = 1.23 W/kg

SAR(1 g) = 0.534 W/kg; SAR(10 g) = 0.237 W/kg

Maximum value of SAR (measured) = 0.613 W/kg

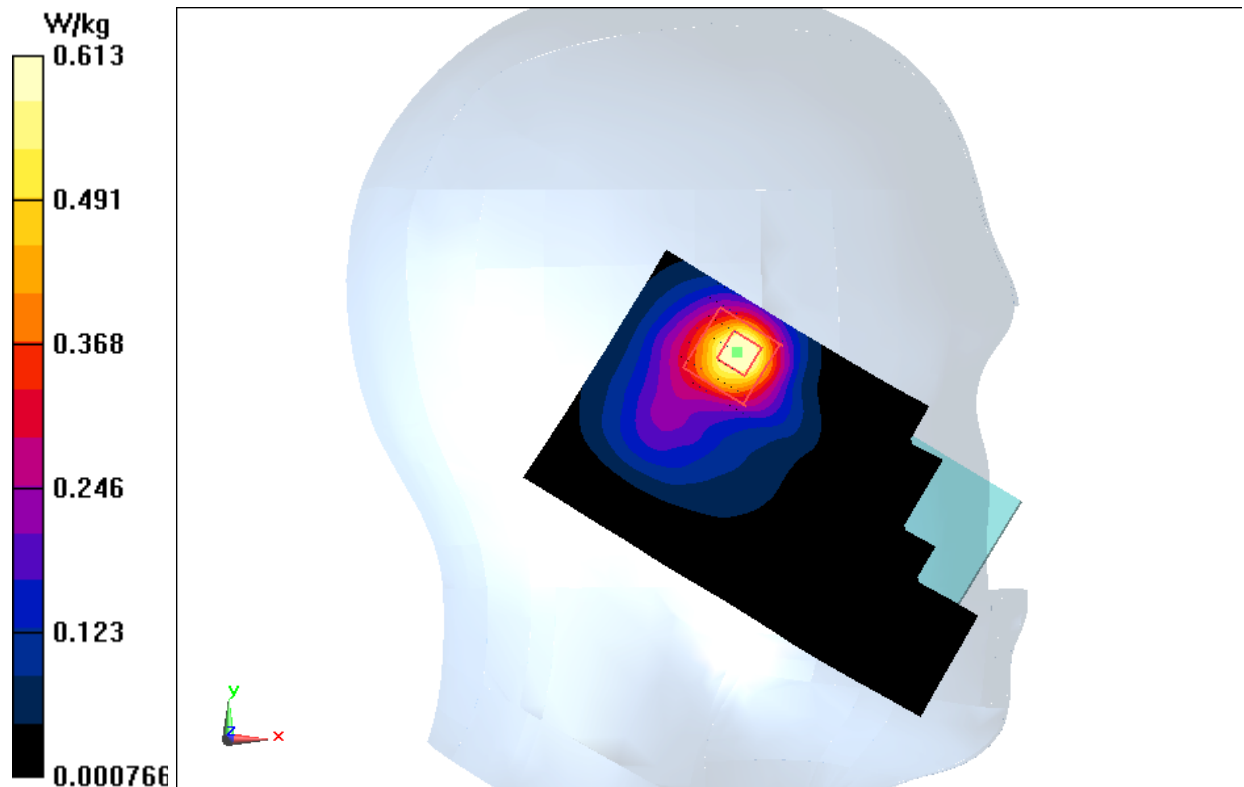

Fig.7 2450 MHz

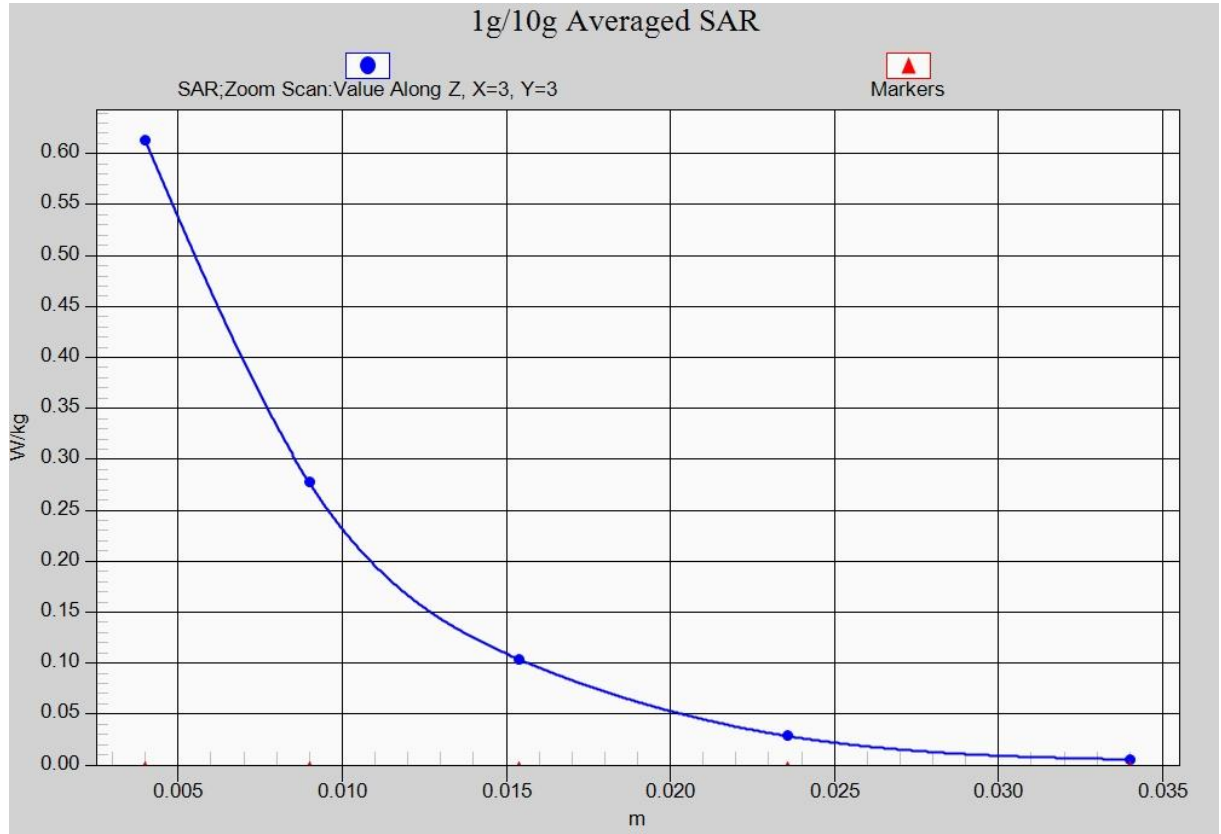

Fig. 7-1 Z-Scan at power reference point (2450 MHz)

Wifi 802.11b Body Rear Channel 11

Date: 2014-12-26

Electronics: DAE4 Sn777

Medium: Body 2450 MHz

Medium parameters used (interpolated): $f = 2462$ MHz; $\sigma = 2.029$ S/m; $\epsilon_r = 50.864$; $\rho = 1000$ kg/m³

Ambient Temperature: 22.0°C Liquid Temperature: 21.6°C

Communication System: WLAN 2450 Frequency: 2462 MHz Duty Cycle: 1:1

Probe: EX3DV4 - SN3846 ConvF(6.90, 6.90, 6.90)

Rear Middle/Area Scan (111x71x1): Interpolated grid: dx=1.000 mm, dy=1.000 mm

Maximum value of SAR (interpolated) = 0.112 W/kg

Rear Middle/Zoom Scan (7x7x7)/Cube 0: Measurement grid: dx=5mm, dy=5mm, dz=5mm

Reference Value = 5.666 V/m; Power Drift = -0.06 dB

Peak SAR (extrapolated) = 0.180 W/kg

SAR(1 g) = 0.093 W/kg; SAR(10 g) = 0.052 W/kg

Maximum value of SAR (measured) = 0.115 W/kg

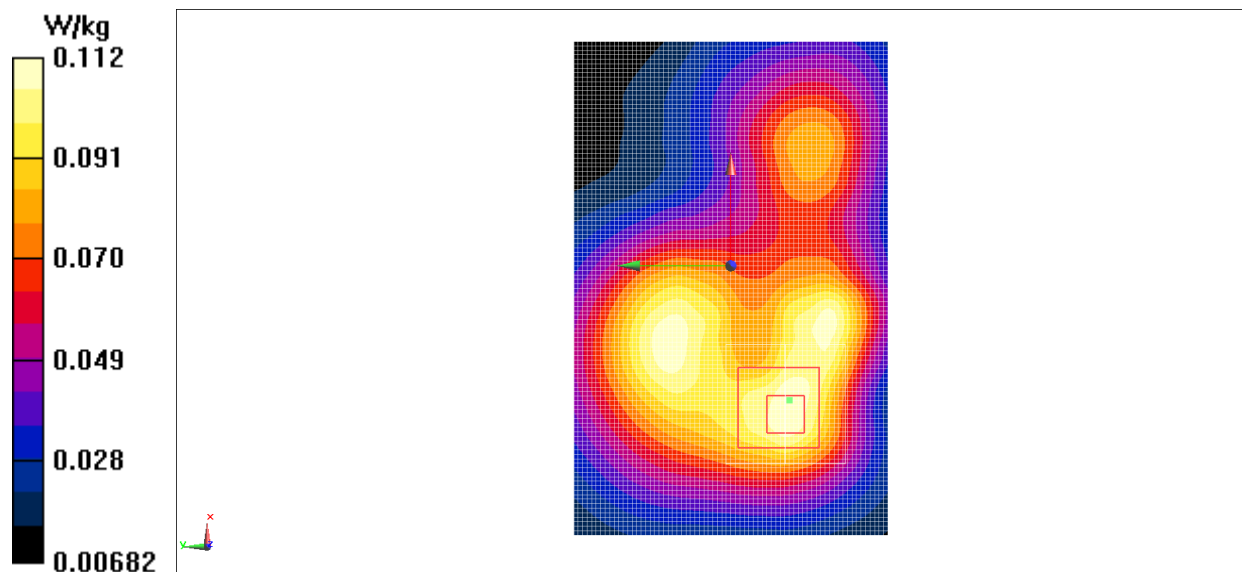

Fig.8 2450 MHz

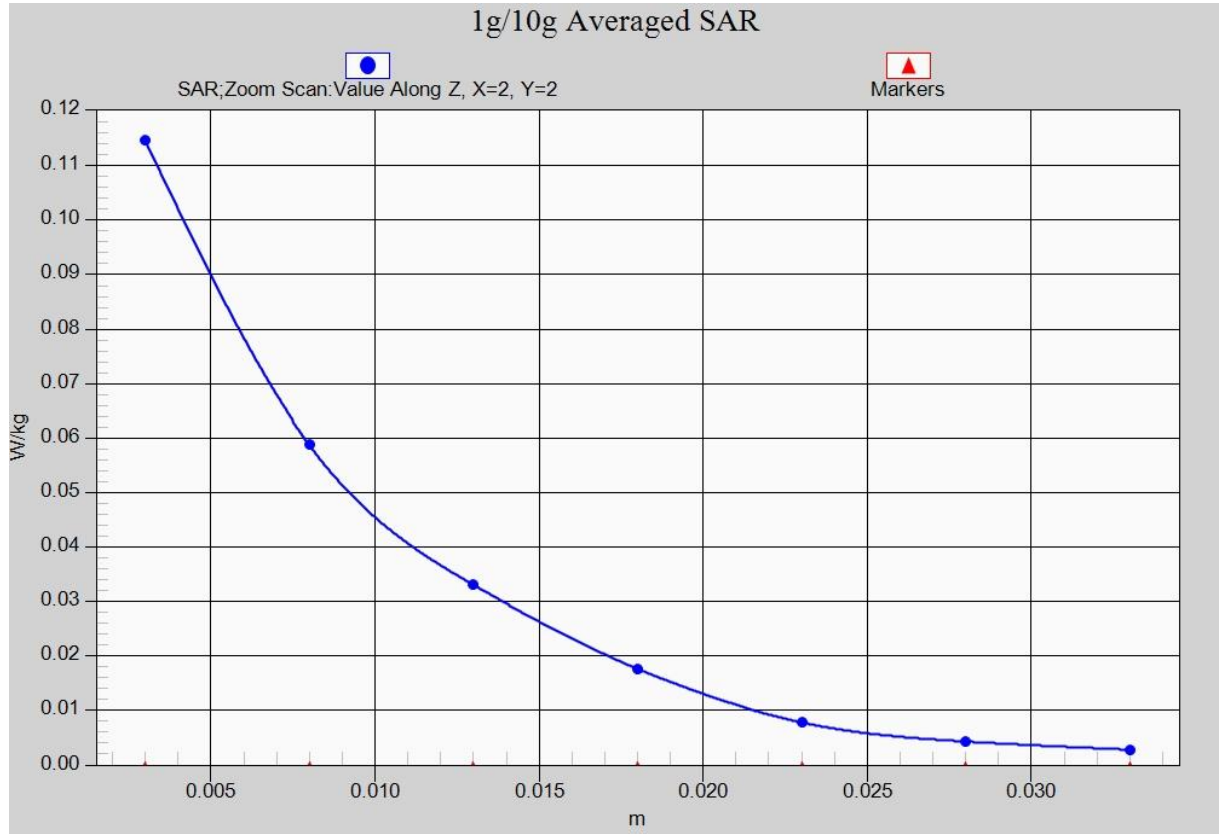

Fig. 8-1 Z-Scan at power reference point (2450 MHz)

ANNEX B System Verification Results

750MHz

Date: 2014-12-23

Electronics: DAE4 Sn777

Medium: Head 750 MHz

Medium parameters used: $f = 750$ MHz; $\sigma = 0.869$ mho/m; $\epsilon_r = 43.35$; $\rho = 1000$ kg/m³

Ambient Temperature: 22.2°C Liquid Temperature: 21.7°C

Communication System: CW Frequency: 750 MHz Duty Cycle: 1:1

Probe: EX3DV4 - SN3846 ConvF(9.53, 9.53, 9.53)

System Validation /Area Scan (81x191x1): Interpolated grid: dx=1.000 mm, dy=1.000 mm

Reference Value = 50.371 V/m; Power Drift = 0.06 dB

Fast SAR: SAR(1 g) = 2.18 W/kg; SAR(10 g) = 1.42 W/kg

Maximum value of SAR (interpolated) = 2.32 W/kg

System Validation /Zoom Scan (7x7x7)/Cube 0: Measurement grid: dx=5mm, dy=5mm, dz=5mm

Reference Value = 50.371 V/m; Power Drift = 0.06 dB

Peak SAR (extrapolated) = 3.01 W/kg

SAR(1 g) = 2.14 W/kg; SAR(10 g) = 1.40 W/kg

Maximum value of SAR (measured) = 2.30 W/kg

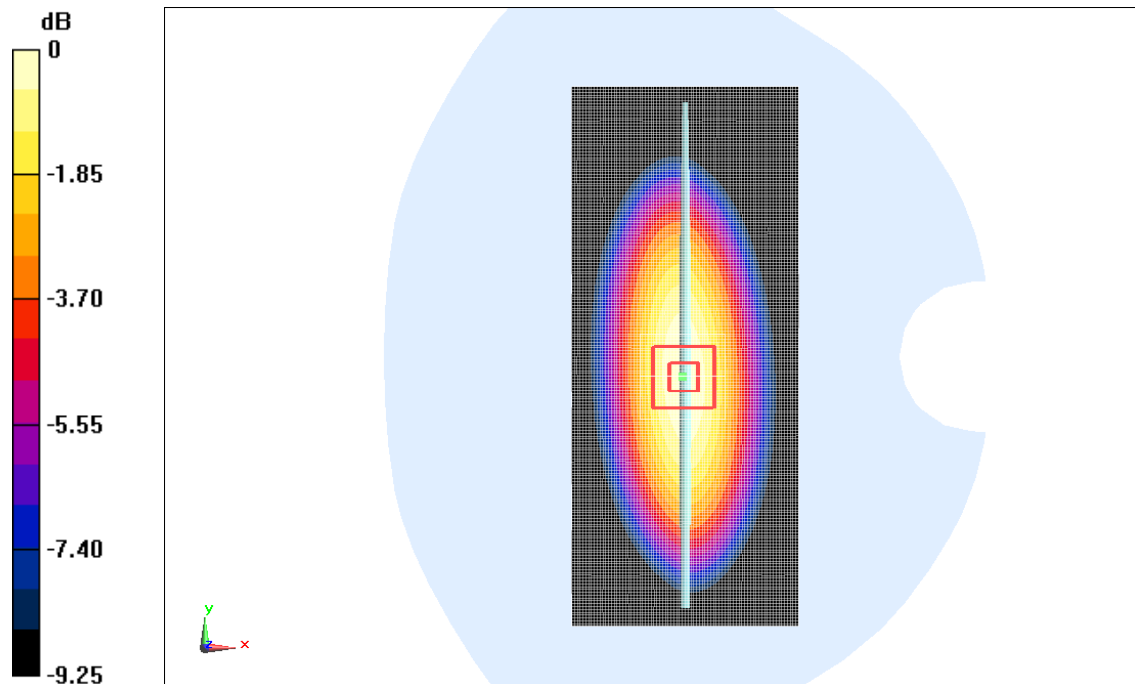

0 dB = 2.30 W/kg = 3.62 dB W/kg

Fig.B.1 validation 750MHz 250mW

750MHz

Date: 2014-12-23

Electronics: DAE4 Sn777

Medium: Body 750 MHz

Medium parameters used: $f = 750 \text{ MHz}$; $\sigma = 0.925 \text{ mho/m}$; $\epsilon_r = 55.53$; $\rho = 1000 \text{ kg/m}^3$

Ambient Temperature: 22.2°C Liquid Temperature: 21.7°C

Communication System: CW Frequency: 750 MHz Duty Cycle: 1:1

Probe: EX3DV4 - SN3846 ConvF(9.18, 9.18, 9.18)

System Validation /Area Scan (81x191x1): Interpolated grid: $dx=1.000 \text{ mm}$, $dy=1.000 \text{ mm}$

Reference Value = 51.774 V/m ; Power Drift = 0.05 dB

Fast SAR: SAR(1 g) = 2.26 W/kg ; SAR(10 g) = 1.47 W/kg

Maximum value of SAR (interpolated) = 2.40 W/kg

System Validation /Zoom Scan (7x7x7)/Cube 0: Measurement grid: $dx=5\text{mm}$, $dy=5\text{mm}$, $dz=5\text{mm}$

Reference Value = 51.774 V/m ; Power Drift = 0.05 dB

Peak SAR (extrapolated) = 3.13 W/kg

SAR(1 g) = 2.23 W/kg ; SAR(10 g) = 1.45 W/kg

Maximum value of SAR (measured) = 2.38 W/kg

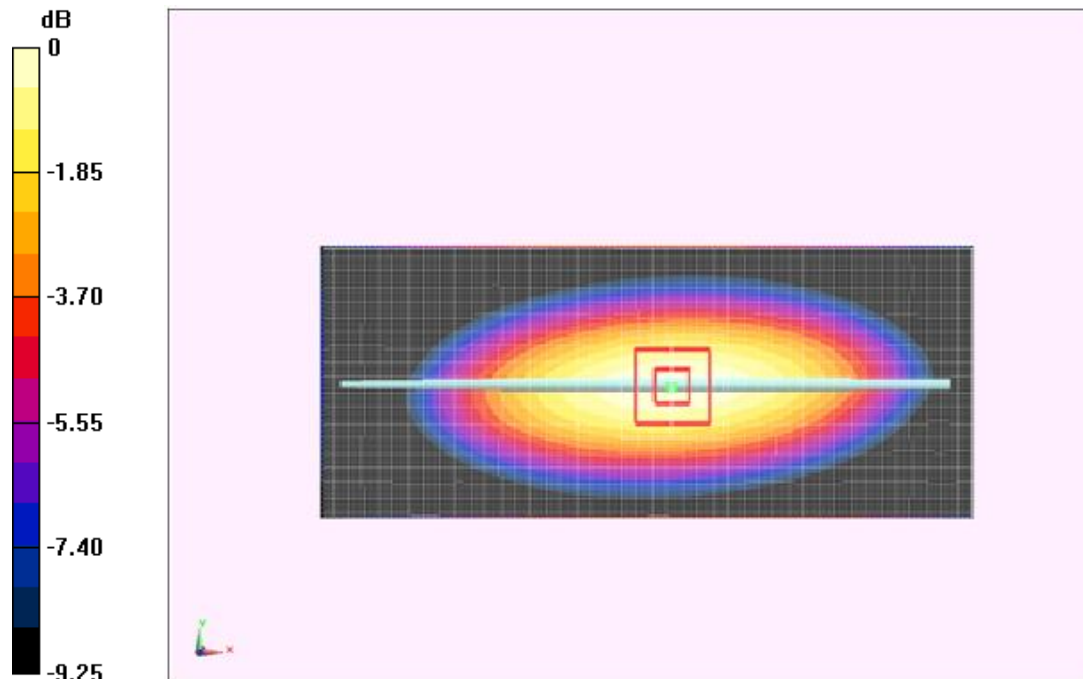

$0 \text{ dB} = 2.38 \text{ W/kg} = 3.77 \text{ dB W/kg}$

Fig.B.2 validation 750MHz 250mW

835MHz

Date: 2014-12-24

Electronics: DAE4 Sn777

Medium: Head 850 MHz

Medium parameters used: $f = 835 \text{ MHz}$; $\sigma = 0.936 \text{ mho/m}$; $\epsilon_r = 42.7$; $\rho = 1000 \text{ kg/m}^3$

Ambient Temperature: 22.2°C Liquid Temperature: 21.7°C

Communication System: CW Frequency: 835 MHz Duty Cycle: 1:1

Probe: EX3DV4 - SN3846 ConvF(9.18, 9.18, 9.18)

System Validation /Area Scan (61x121x1): Interpolated grid: $dx=1.000 \text{ mm}$, $dy=1.000 \text{ mm}$

Reference Value = 48.905 V/m ; Power Drift = -0.04 dB

SAR(1 g) = 2.38 W/kg ; SAR(10 g) = 1.54 W/kg

Maximum value of SAR (interpolated) = 2.83 W/kg

System Validation /Zoom Scan (7x7x7)/Cube 0: Measurement grid: $dx=5\text{mm}$, $dy=5\text{mm}$, $dz=5\text{mm}$

Reference Value = 48.905 V/m ; Power Drift = -0.04 dB

Peak SAR (extrapolated) = 3.62 W/kg

SAR(1 g) = 2.43 W/kg ; SAR(10 g) = 1.57 W/kg

Maximum value of SAR (measured) = 2.85 W/kg

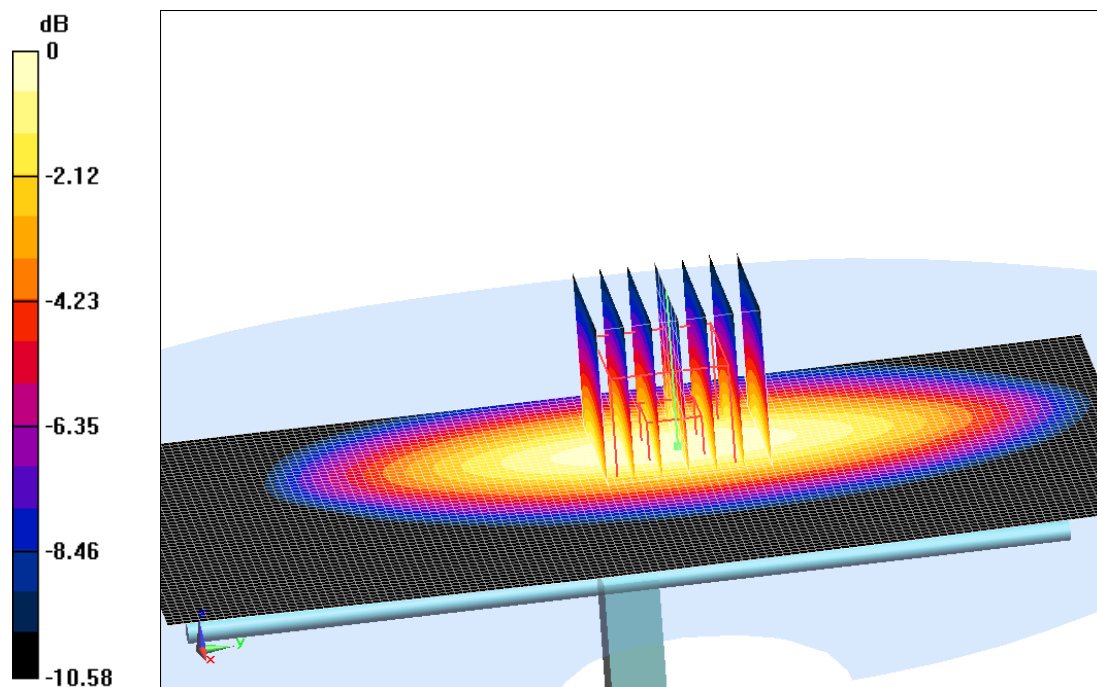

$0 \text{ dB} = 2.85 \text{ W/kg} = 4.55 \text{ dBW/kg}$

Fig.B.3 validation 835MHz 250mW

835MHz

Date: 2014-12-24

Electronics: DAE4 Sn777

Medium: Body 850 MHz

Medium parameters used: $f = 835 \text{ MHz}$; $\sigma = 0.963 \text{ S/m}$; $\epsilon_r = 54.85$; $\rho = 1000 \text{ kg/m}^3$

Ambient Temperature: 22.2°C Liquid Temperature: 21.7°C

Communication System: CW Frequency: 835 MHz Duty Cycle: 1:1

Probe: EX3DV4 - SN3846 ConvF(9.09, 9.09, 9.09)

System Validation /Area Scan (61x121x1): Interpolated grid: $dx=1.000 \text{ mm}$, $dy=1.000 \text{ mm}$

Reference Value = 53.148 V/m ; Power Drift = 0.09 dB

Fast SAR: SAR(1 g) = 2.42 W/kg ; SAR(10 g) = 1.57 W/kg

Maximum value of SAR (interpolated) = 2.78 W/kg

System Validation /Zoom Scan (7x7x7)/Cube 0: Measurement grid: $dx=5\text{mm}$, $dy=5\text{mm}$, $dz=5\text{mm}$

Reference Value = 53.148 V/m ; Power Drift = 0.09 dB

Peak SAR (extrapolated) = 3.44 W/kg

SAR(1 g) = 2.38 W/kg ; SAR(10 g) = 1.55 W/kg

Maximum value of SAR (measured) = 2.75 W/kg

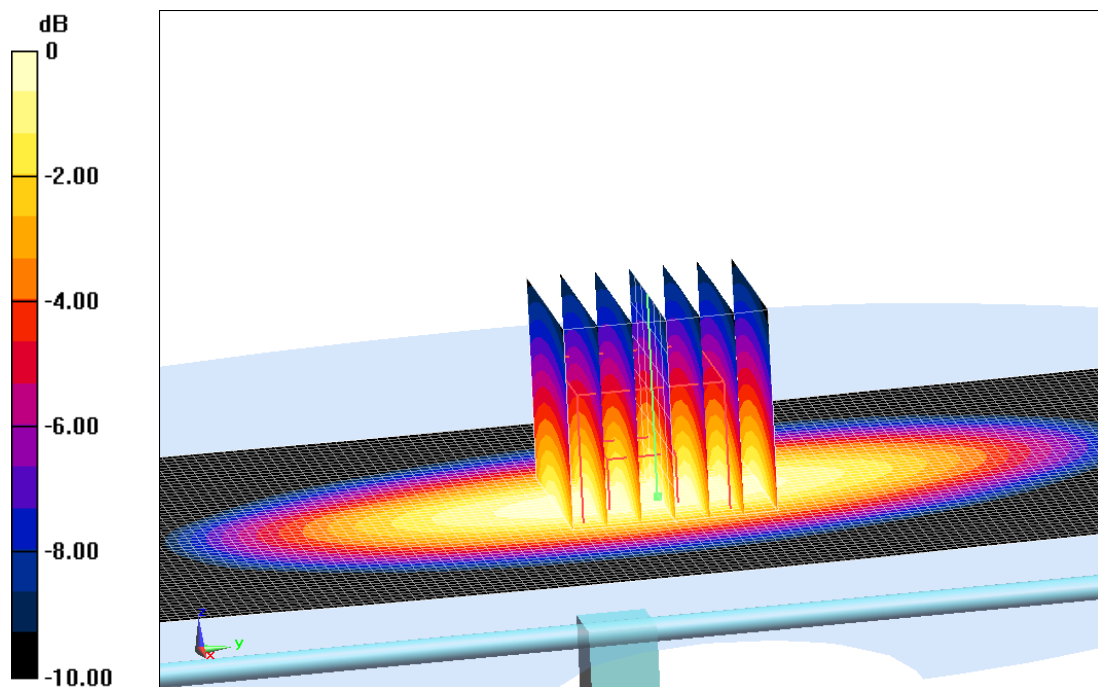

0 dB = 2.75 W/kg = 4.39 dBW/kg

Fig.B.4 validation 835MHz 250mW

1900MHz

Date: 2014-12-25

Electronics: DAE4 Sn777

Medium: Head 1900 MHz

Medium parameters used: $f = 1900 \text{ MHz}$; $\sigma = 1.389 \text{ mho/m}$; $\epsilon_r = 40.18$; $\rho = 1000 \text{ kg/m}^3$

Ambient Temperature: 22.0°C Liquid Temperature: 21.6°C

Communication System: CW Frequency: 1900 MHz Duty Cycle: 1:1

Probe: EX3DV4 - SN3846 ConvF(7.26, 7.26, 7.26)

System Validation /Area Scan (61x81x1): Interpolated grid: $dx=1.000 \text{ mm}$, $dy=1.000 \text{ mm}$

Reference Value = 91.547 V/m ; Power Drift = 0.05 dB

SAR(1 g) = 9.97 W/kg ; SAR(10 g) = 5.28 W/kg

Maximum value of SAR (interpolated) = 12.7 W/kg

System Validation /Zoom Scan (7x7x7)/Cube 0: Measurement grid: $dx=5\text{mm}$, $dy=5\text{mm}$, $dz=5\text{mm}$

Reference Value = 91.547 V/m ; Power Drift = 0.05 dB

Peak SAR (extrapolated) = 18.04 W/kg

SAR(1 g) = 9.85 W/kg ; SAR(10 g) = 5.18 W/kg

Maximum value of SAR (measured) = 12.0 W/kg

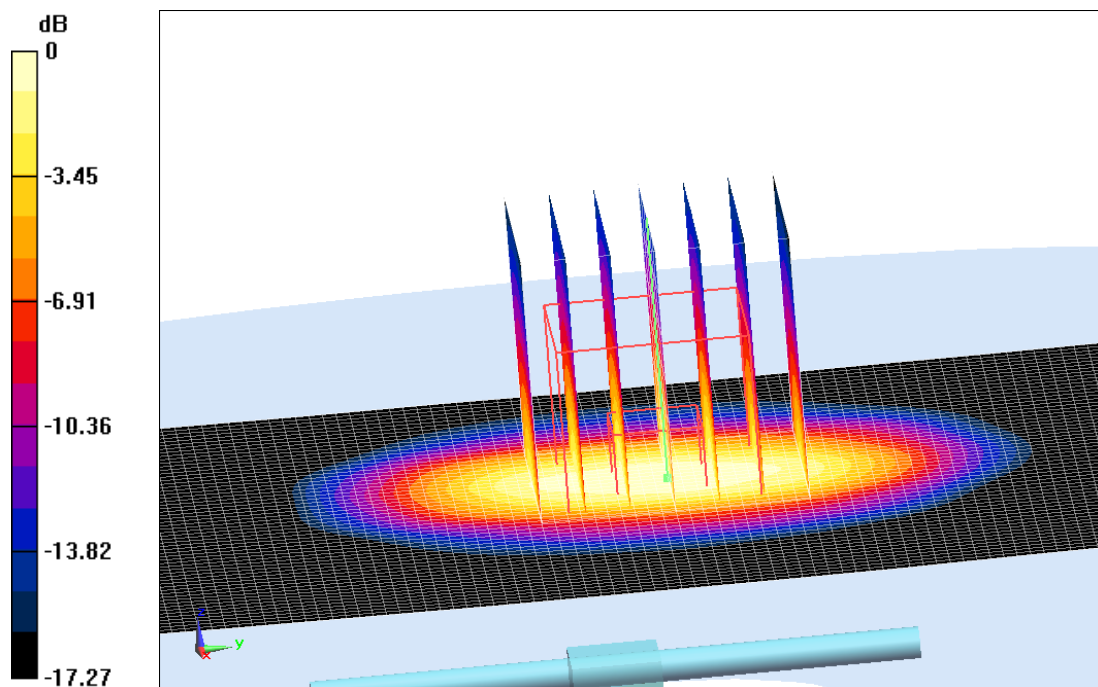

$0 \text{ dB} = 12.0 \text{ W/kg} = 10.79 \text{ dBW/kg}$

Fig.B.5 validation 1900MHz 250mW

1900MHz

Date: 2014-12-25

Electronics: DAE4 Sn777

Medium: Body 1900 MHz

Medium parameters used: $f = 1900$ MHz; $\sigma = 1.508$ S/m; $\epsilon_r = 54.06$; $\rho = 1000$ kg/m³

Ambient Temperature: 22.0°C Liquid Temperature: 21.6°C

Communication System: CW Frequency: 1900 MHz Duty Cycle: 1:1

Probe: EX3DV4 - SN3846 ConvF(7.15, 7.15, 7.15)

System Validation/Area Scan (81x121x1): Interpolated grid: dx=1.000 mm, dy=1.000 mm

Reference Value = 68.82 V/m; Power Drift = 0.06 dB

Fast SAR: SAR(1 g) = 10.4 W/kg; SAR(10 g) = 5.51 W/kg

Maximum value of SAR (interpolated) = 11.8 W/kg

System Validation/Zoom Scan (7x7x7)/Cube 0: Measurement grid: dx=5mm, dy=5mm, dz=5mm

Reference Value = 68.82 V/m; Power Drift = 0.06 dB

Peak SAR (extrapolated) = 19.23 W/kg

SAR(1 g) = 10.3 W/kg; SAR(10 g) = 5.43 W/kg

Maximum value of SAR (measured) = 11.7 W/kg

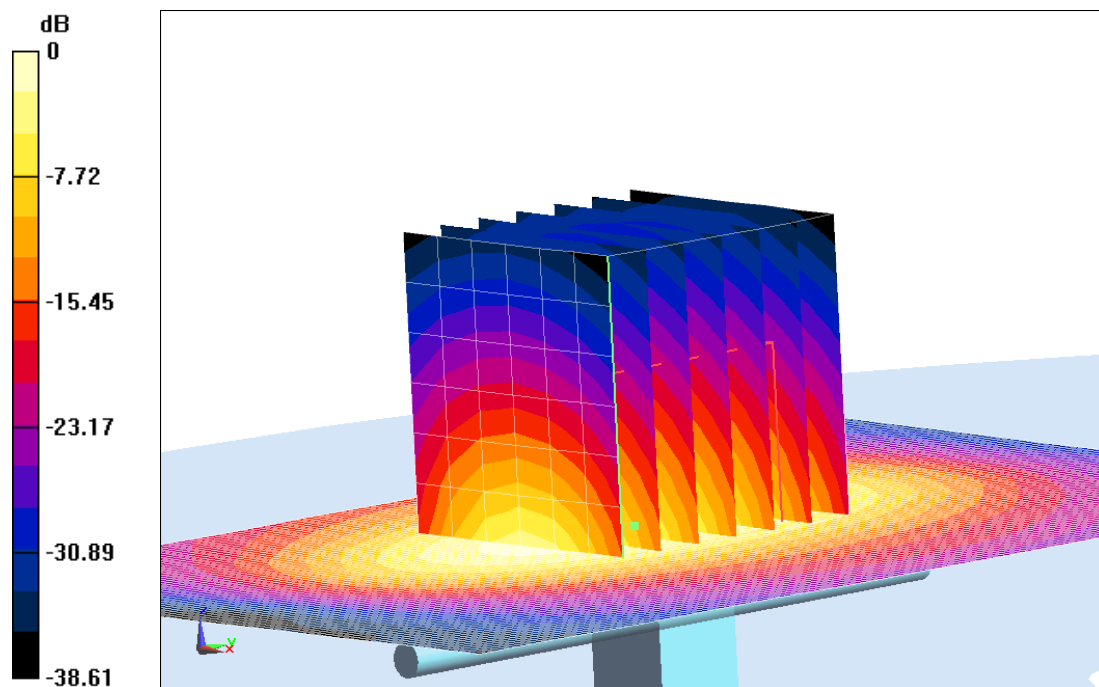

0 dB = 11.7 W/kg = 10.68 dB W/kg

Fig.B.6 validation 1900MHz 250mW

2450MHz

Date: 2014-12-26

Electronics: DAE4 Sn777

Medium: Head 2450 MHz

Medium parameters used: $f = 2450 \text{ MHz}$; $\sigma = 1.84 \text{ mho/m}$; $\epsilon_r = 40.2$; $\rho = 1000 \text{ kg/m}^3$

Ambient Temperature: 22.0°C Liquid Temperature: 21.6°C

Communication System: CW Frequency: 2450 MHz Duty Cycle: 1:1

Probe: EX3DV4 - SN3846 ConvF(6.56, 6.56, 6.56)

System Validation /Area Scan (61x81x1): Interpolated grid: $dx=1.000 \text{ mm}$, $dy=1.000 \text{ mm}$

Reference Value = 87.004 V/m ; Power Drift = -0.03 dB

SAR(1 g) = 13.2 W/kg ; SAR(10 g) = 6.19 W/kg

Maximum value of SAR (interpolated) = 17.3 W/kg

System Validation /Zoom Scan (7x7x7)/Cube 0: Measurement grid: $dx=5\text{mm}$, $dy=5\text{mm}$, $dz=5\text{mm}$

Reference Value = 87.004 V/m ; Power Drift = -0.03 dB

Peak SAR (extrapolated) = 27.01 W/kg

SAR(1 g) = 13.0 W/kg ; SAR(10 g) = 6.06 W/kg

Maximum value of SAR (measured) = 16.3 W/kg

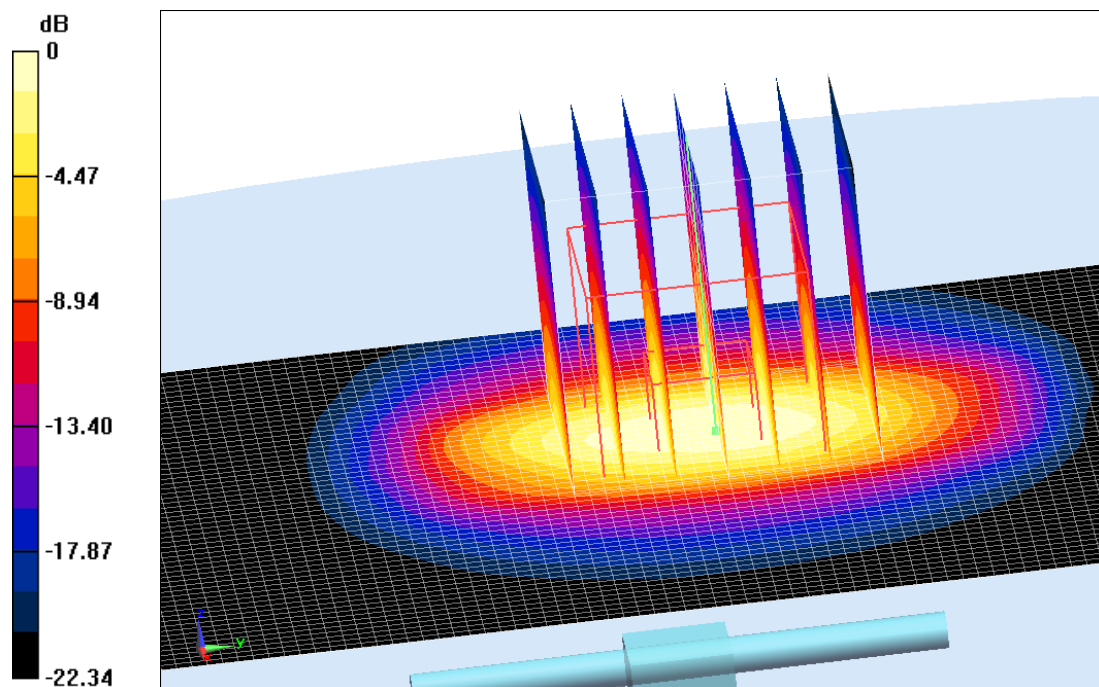

$0 \text{ dB} = 16.3 \text{ W/kg} = 12.12 \text{ dBW/kg}$

Fig.B.7 validation 2450MHz 250mW

2450MHz

Date: 2014-12-26

Electronics: DAE4 Sn777

Medium: Body 2450 MHz

Medium parameters used: $f = 2450 \text{ MHz}$; $\sigma = 2.018 \text{ S/m}$; $\epsilon_r = 50.88$; $\rho = 1000 \text{ kg/m}^3$

Ambient Temperature: 22.0°C Liquid Temperature: 21.6°C

Communication System: CW Frequency: 2450 MHz Duty Cycle: 1:1

Probe: EX3DV4 - SN3846 ConvF(6.90, 6.90, 6.90)

System Validation/Area Scan (81x101x1): Interpolated grid: $dx=1.000 \text{ mm}$, $dy=1.000 \text{ mm}$

Reference Value = 87.792 V/m ; Power Drift = 0.07 dB

SAR(1 g) = 12.3 W/kg ; SAR(10 g) = 5.75 W/kg

Maximum value of SAR (interpolated) = 14.1 W/kg

System Validation/Zoom Scan (7x7x7)/Cube 0: Measurement grid: $dx=5\text{mm}$, $dy=5\text{mm}$, $dz=5\text{mm}$

Reference Value = 87.792 V/m ; Power Drift = 0.07 dB

Peak SAR (extrapolated) = 24.49 W/kg

SAR(1 g) = 12.4 W/kg ; SAR(10 g) = 5.84 W/kg

Maximum value of SAR (measured) = 14.2 W/kg

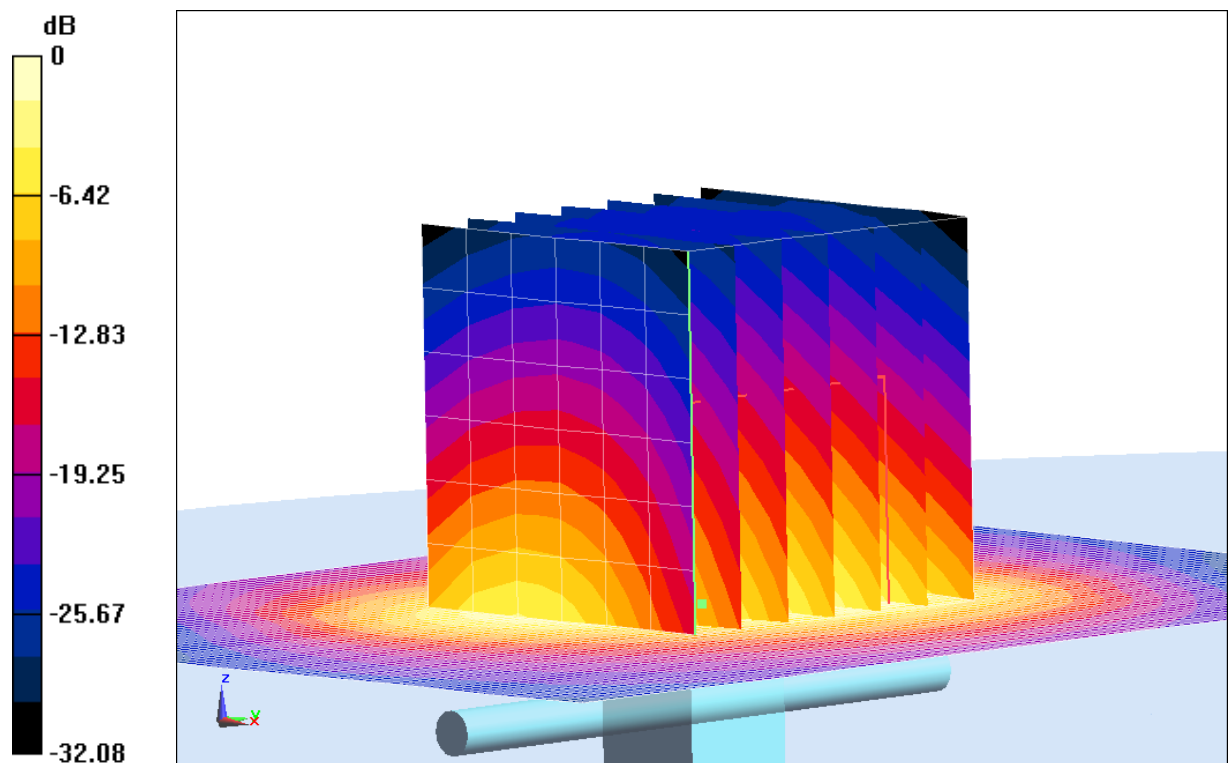

0 dB = 14.2 W/kg = 11.52 dB W/kg

Fig.B.8 validation 2450MHz 250mW

The SAR system verification must be required that the area scan estimated 1-g SAR is within 3% of the zoom scan 1-g SAR.

Table B.1 Comparison between area scan and zoom scan for system verification

Band	Position	Area scan (1g)	Zoom scan (1g)	Drift (%)
750	Head	2.18	2.14	1.87
750	Body	2.26	2.23	1.35
835	Head	2.38	2.43	-2.06
835	Body	2.42	2.38	1.68
1900	Head	9.97	9.85	1.22
1900	Body	10.4	10.3	0.97
2450	Head	13.2	13.0	1.54
2450	Body	12.3	12.4	-0.81

ANNEX C SAR Measurement Setup

C.1 Measurement Set-up

The Dasy4 or DASY5 system for performing compliance tests is illustrated above graphically. This system consists of the following items:

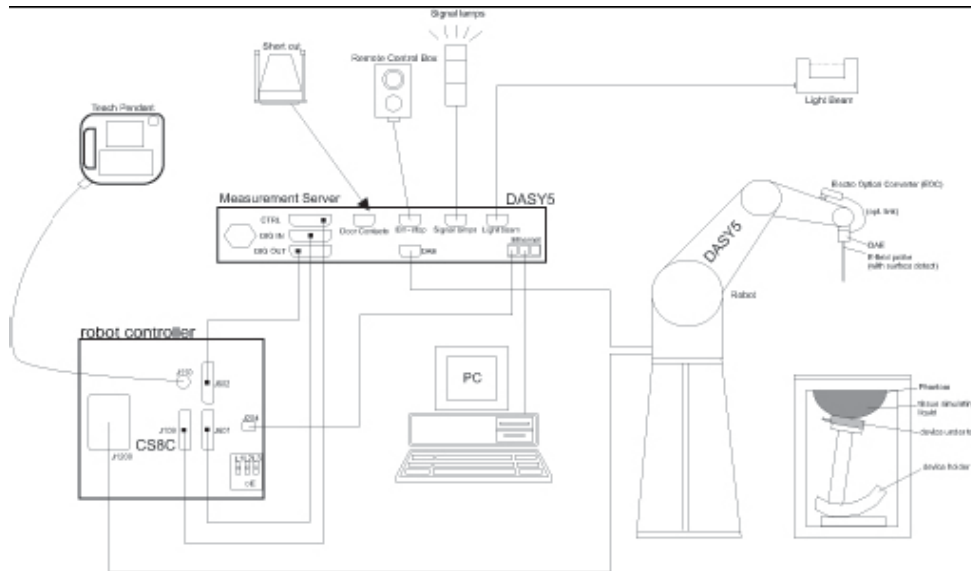

Picture C.1 SAR Lab Test Measurement Set-up

- A standard high precision 6-axis robot (Stäubli TX=RX family) with controller, teach pendant and software. An arm extension for accommodating the data acquisition electronics (DAE).
- An isotropic field probe optimized and calibrated for the targeted measurement.
- A data acquisition electronics (DAE) which performs the signal amplification, signal multiplexing, AD-conversion, offset measurements, mechanical surface detection, collision detection, etc. The unit is battery powered with standard or rechargeable batteries. The signal is optically transmitted to the EOC.
- The Electro-optical converter (EOC) performs the conversion from optical to electrical signals for the digital communication to the DAE. To use optical surface detection, a special version of the EOC is required. The EOC signal is transmitted to the measurement server.
- The function of the measurement server is to perform the time critical tasks such as signal filtering, control of the robot operation and fast movement interrupts.
- The Light Beam used is for probe alignment. This improves the (absolute) accuracy of the probe positioning.
- A computer running WinXP and the DASY4 or DASY5 software.
- Remote control and teach pendant as well as additional circuitry for robot safety such as
- warning lamps, etc.
- The phantom, the device holder and other accessories according to the targeted measurement.

C.2 Dasy4 or DASY5 E-field Probe System

The SAR measurements were conducted with the dosimetric probe designed in the classical triangular configuration and optimized for dosimetric evaluation. The probe is constructed using the thick film technique; with printed resistive lines on ceramic substrates. The probe is equipped with an optical multifiber line ending at the front of the probe tip. It is connected to the EOC box on the robot arm and provides an automatic detection of the phantom surface. Half of the fibers are connected to a pulsed infrared transmitter, the other half to a synchronized receiver. As the probe approaches the surface, the reflection from the surface produces a coupling from the transmitting to the receiving fibers. This reflection increases first during the approach, reaches maximum and then decreases. If the probe is flatly touching the surface, the coupling is zero. The distance of the coupling maximum to the surface is independent of the surface reflectivity and largely independent of the surface to probe angle. The DASY4 or DASY5 software reads the reflection during a software approach and looks for the maximum using 2nd order curve fitting. The approach is stopped at reaching the maximum.

Probe Specifications:

Model:	ES3DV3, EX3DV4
Frequency	10MHz — 6.0GHz(EX3DV4)
Range:	10MHz — 4GHz(ES3DV3)
Calibration:	In head and body simulating tissue at Frequencies from 835 up to 5800MHz
Linearity:	± 0.2 dB(30 MHz to 6 GHz) for EX3DV4 ± 0.2 dB(30 MHz to 4 GHz) for ES3DV3
Dynamic Range:	10 mW/kg — 100W/kg
Probe Length:	330 mm
Probe Tip	
Length:	20 mm
Body Diameter:	12 mm
Tip Diameter:	2.5 mm (3.9 mm for ES3DV3)
Tip-Center:	1 mm (2.0mm for ES3DV3)
Application:	SAR Dosimetry Testing Compliance tests of mobile phones Dosimetry in strong gradient fields



Picture C.2 Near-field Probe



Picture C.3 E-field Probe

C.3 E-field Probe Calibration

Each E-Probe/Probe Amplifier combination has unique calibration parameters. A TEM cell calibration procedure is conducted to determine the proper amplifier settings to enter in the probe parameters. The amplifier settings are determined for a given frequency by subjecting the probe to a known E-field density (1 mW/cm^2) using an RF Signal generator, TEM cell, and RF Power Meter.

The free space E-field from amplified probe outputs is determined in a test chamber. This calibration can be performed in a TEM cell if the frequency is below 1 GHz and in a waveguide or other methodologies above 1 GHz for free space. For the free space calibration, the probe is placed

in the volumetric center of the cavity and at the proper orientation with the field. The probe is then rotated 360 degrees until the three channels show the maximum reading. The power density readings equates to 1 mW/ cm²:

E-field temperature correlation calibration is performed in a flat phantom filled with the appropriate simulated brain tissue. The E-field in the medium correlates with the temperature rise in the dielectric medium. For temperature correlation calibration a RF transparent thermistor-based temperature probe is used in conjunction with the E-field probe.

$$SAR = C \frac{\Delta T}{\Delta t}$$

Where:

Δt = Exposure time (30 seconds),

C = Heat capacity of tissue (brain or muscle),

ΔT = Temperature increase due to RF exposure.

$$SAR = \frac{|E|^2 \cdot \sigma}{\rho}$$

Where:

σ = Simulated tissue conductivity,

ρ = Tissue density (kg/m³).

C.4 Other Test Equipment

C.4.1 Data Acquisition Electronics(DAE)

The data acquisition electronics consist of a highly sensitive electrometer-grade preamplifier with auto-zeroing, a channel and gain-switching multiplexer, a fast 16 bit AD-converter and a command decoder with a control logic unit. Transmission to the measurement server is accomplished through an optical downlink for data and status information, as well as an optical uplink for commands and the clock.

The mechanical probe mounting device includes two different sensor systems for frontal and sideways probe contacts. They are used for mechanical surface detection and probe collision detection.

The input impedance of the DAE is 200 MOhm; the inputs are symmetrical and floating. Common mode rejection is above 80 dB.



PictureC.4: DAE

C.4.2 Robot

The SPEAG DASY system uses the high precision robots (DASY4: RX90XL; DASY5: RX160L) type from Stäubli SA (France). For the 6-axis controller system, the robot controller version from Stäubli is used. The Stäubli robot series have many features that are important for our application:

- High precision (repeatability 0.02mm)
- High reliability (industrial design)
- Low maintenance costs (virtually maintenance free due to direct drive gears; no belt drives)
- Jerk-free straight movements (brushless synchron motors; no stepper motors)
- Low ELF interference (motor control fields shielded via the closed metallic construction shields)



Picture C.5 DASY 4



Picture C.6 DASY 5

C.4.3 Measurement Server

The Measurement server is based on a PC/104 CPU board with CPU (dasy4: 166 MHz, Intel Pentium; DASY5: 400 MHz, Intel Celeron), chipdisk (DASY4: 32 MB; DASY5: 128MB), RAM (DASY4: 64 MB, DASY5: 128MB). The necessary circuits for communication with the DAE electronic box, as well as the 16 bit AD converter system for optical detection and digital I/O interface are contained on the DASY I/O board, which is directly connected to the PC/104 bus of the CPU board.

The measurement server performs all real-time data evaluation of field measurements and surface detection, controls robot movements and handles safety operation. The PC operating system cannot interfere with these time critical processes. All connections are supervised by a watchdog, and disconnection of any of the cables to the measurement server will automatically disarm the robot and disable all program-controlled robot movements. Furthermore, the measurement server is equipped with an expansion port which is reserved for future applications. Please note that this expansion port does not have a standardized pinout, and therefore only devices provided by SPEAG can be connected. Devices from any other supplier could seriously damage the measurement server.



Picture C.7 Server for DASY 4



Picture C.8 Server for DASY 5

C.4.4 Device Holder for Phantom

The SAR in the phantom is approximately inversely proportional to the square of the distance between the source and the liquid surface. For a source at 5mm distance, a positioning uncertainty of $\pm 0.5\text{mm}$ would produce a SAR uncertainty of $\pm 20\%$. Accurate device positioning is therefore crucial for accurate and repeatable measurements. The positions in which the devices must be measured are defined by the standards.

The DASY device holder is designed to cope with the different positions given in the standard. It has two scales for device rotation (with respect to the body axis) and device inclination (with respect to the line between the ear reference points). The rotation centers for both scales is the ear reference point (ERP). Thus the device needs no repositioning when changing the angles.

The DASY device holder is constructed of low-loss POM material having the following dielectric

parameters: relative permittivity $\epsilon = 3$ and loss tangent $\delta = 0.02$. The amount of dielectric material has been reduced in the closest vicinity of the device, since measurements have suggested that the influence of the clamp on the test results could thus be lowered.

<Laptop Extension Kit>

The extension is lightweight and made of POM, acrylic glass and foam. It fits easily on the upper part of the Mounting Device in place of the phone positioner. The extension is fully compatible with the Twin-SAM and ELI phantoms.



Picture C.9-1: Device Holder

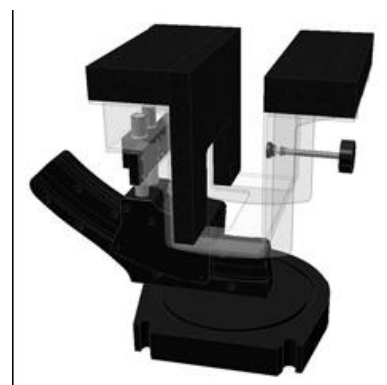

Picture C.9-2: Laptop Extension Kit

C.4.5 Phantom

The SAM Twin Phantom V4.0 is constructed of a fiberglass shell integrated in a table. The shape of the shell is based on data from an anatomical study designed to

Represent the 90th percentile of the population. The phantom enables the dissymmetric evaluation

of SAR for both left and right handed handset usage, as well as body-worn usage using the flat phantom region. Reference markings on the Phantom allow the complete setup of all predefined phantom positions and measurement grids by manually teaching three points in the robot. The shell phantom has a 2mm shell thickness (except the ear region where shell thickness increases to 6 mm).

Shell Thickness: 2 ± 0.2 mm

Filling Volume: Approx. 25 liters

Dimensions: 810 x 1000 x 500 mm (H x L x W)

Available: Special



Picture C.10: SAM Twin Phantom

ANNEX D Position of the wireless device in relation to the phantom

D.1 General considerations

This standard specifies two handset test positions against the head phantom – the “cheek” position and the “tilt” position.

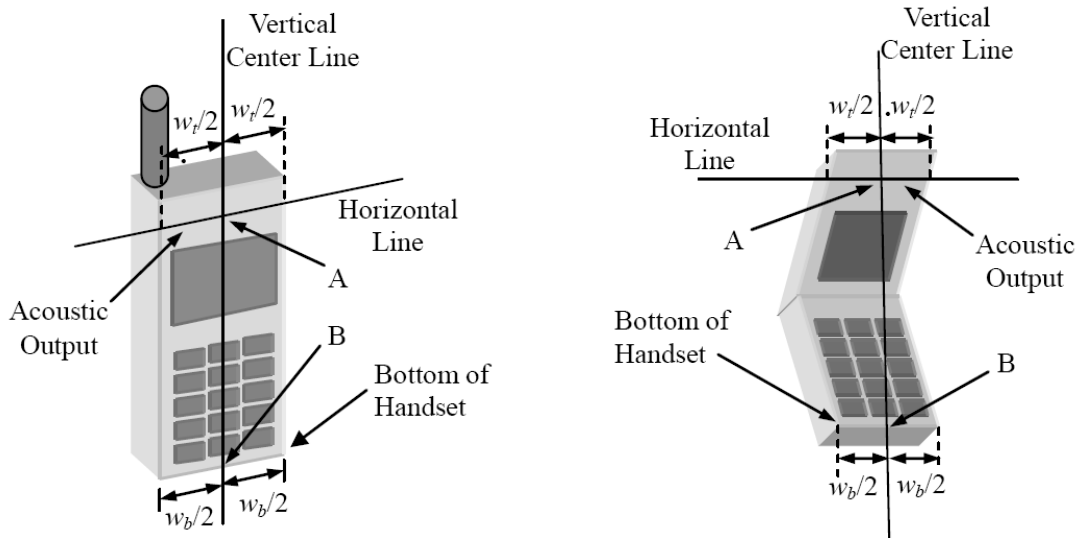

- w_t Width of the handset at the level of the acoustic
- w_b Width of the bottom of the handset
- A Midpoint of the width w_t of the handset at the level of the acoustic output
- B Midpoint of the width w_b of the bottom of the handset

Picture D.1-a Typical “fixed” case handset Picture D.1-b Typical “clam-shell” case handset

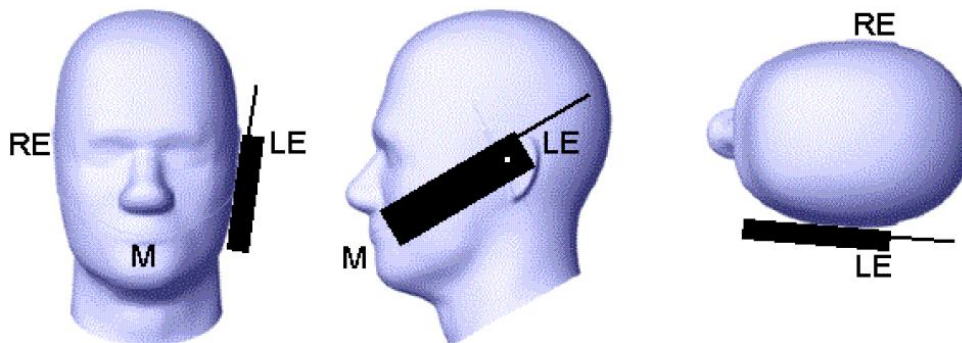

Picture D.2 Cheek position of the wireless device on the left side of SAM

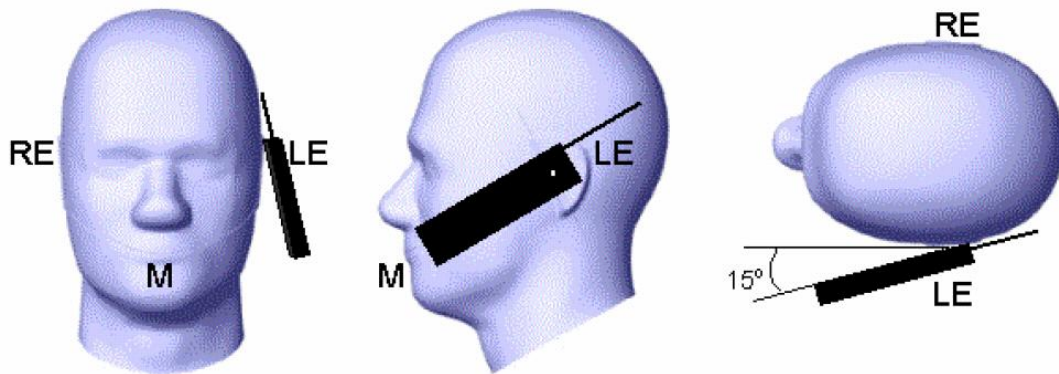

Picture D.3 Tilt position of the wireless device on the left side of SAM

D.2 Body-worn device

A typical example of a body-worn device is a mobile phone, wireless enabled PDA or other battery operated wireless device with the ability to transmit while mounted on a person's body using a carry accessory approved by the wireless device manufacturer.

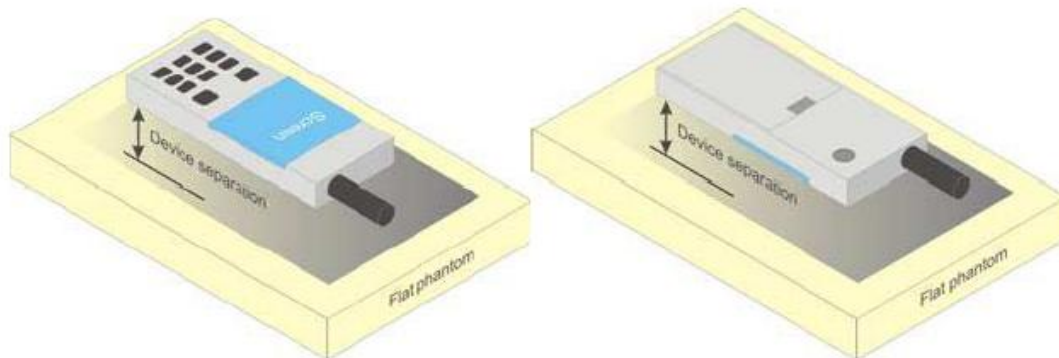

Picture D.4 Test positions for body-worn devices

D.3 Desktop device

A typical example of a desktop device is a wireless enabled desktop computer placed on a table or desk when used.

The DUT shall be positioned at the distance and in the orientation to the phantom that corresponds to the intended use as specified by the manufacturer in the user instructions. For devices that employ an external antenna with variable positions, tests shall be performed for all antenna positions specified. Picture 8.5 show positions for desktop device SAR tests. If the intended use is not specified, the device shall be tested directly against the flat phantom.

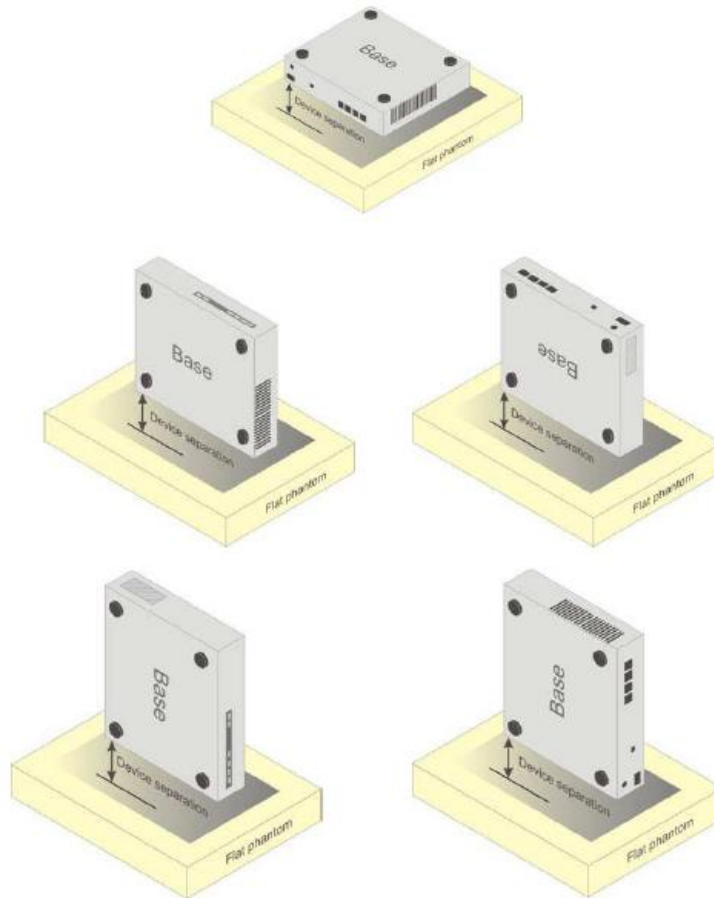

Picture D.5 Test positions for desktop devices

D.4 DUT Setup Photos



Picture D.6

ANNEX E Equivalent Media Recipes

The liquid used for the frequency range of 800-3000 MHz consisted of water, sugar, salt, preventol, glycol monobutyl and Cellulose. The liquid has been previously proven to be suited for worst-case. The Table E.1 shows the detail solution. It's satisfying the latest tissue dielectric parameters requirements proposed by the IEEE 1528 and IEC 62209.

Table E.1: Composition of the Tissue Equivalent Matter

Frequency (MHz)	835 Head	835 Body	1900 Head	1900 Body	2450 Head	2450 Body	5800 Head	5800 Body
Ingredients (% by weight)								
Water	41.45	52.5	55.242	69.91	58.79	72.60	65.53	65.53
Sugar	56.0	45.0	\	\	\	\	\	\
Salt	1.45	1.4	0.306	0.13	0.06	0.18	\	\
Preventol	0.1	0.1	\	\	\	\	\	\
Cellulose	1.0	1.0	\	\	\	\	\	\
Glycol Monobutyl	\	\	44.452	29.96	41.15	27.22	\	\
Diethyleneglycol monohexylether	\	\	\	\	\	\	17.24	17.24
Triton X-100	\	\	\	\	\	\	17.24	17.24
Dielectric Parameters Target Value	$\epsilon=41.5$ $\sigma=0.90$	$\epsilon=55.2$ $\sigma=0.97$	$\epsilon=40.0$ $\sigma=1.40$	$\epsilon=53.3$ $\sigma=1.52$	$\epsilon=39.2$ $\sigma=1.80$	$\epsilon=52.7$ $\sigma=1.95$	$\epsilon=35.3$ $\sigma=5.27$	$\epsilon=48.2$ $\sigma=6.00$

Note: There are a little adjustment respectively for 750, 1750, 2600, 5200, 5300 and 5600 based on the recipe of closest frequency in table E.1.

ANNEX F System Validation

The SAR system must be validated against its performance specifications before it is deployed. When SAR probes, system components or software are changed, upgraded or recalibrated, these must be validated with the SAR system(s) that operates with such components.

Table F.1: System Validation

Probe SN.	Liquid name	Validation date	Frequency point	Status (OK or Not)
3846	Head 750MHz	Oct.25,2014	750 MHz	OK
3846	Head 850MHz	Oct.25,2014	850 MHz	OK
3846	Head 900MHz	Oct.26,2014	900 MHz	OK
3846	Head 1750MHz	Oct.27,2014	1750 MHz	OK
3846	Head 1810MHz	Oct.27,2014	1810 MHz	OK
3846	Head 1900MHz	Oct.28,2014	1900 MHz	OK
3846	Head 1950MHz	Oct.28,2014	1950 MHz	OK
3846	Head 2000MHz	Oct.28,2014	2000 MHz	OK
3846	Head 2100MHz	Oct.28,2014	2100 MHz	OK
3846	Head 2300MHz	Oct.29,2014	2300 MHz	OK
3846	Head 2450MHz	Oct.29,2014	2450 MHz	OK
3846	Head 2550MHz	Oct.29,2014	2550 MHz	OK
3846	Head 2600MHz	Oct.29,2014	2600 MHz	OK
3846	Head 3500MHz	Oct.30,2014	3500 MHz	OK
3846	Head 3700MHz	Oct.30,2014	3700 MHz	OK
3846	Head 5200MHz	Oct.24,2014	5200 MHz	OK
3846	Head 5500MHz	Oct.24,2014	5500 MHz	OK
3846	Head 5800MHz	Oct.24,2014	5800 MHz	OK
3846	Body 750MHz	Oct.25,2014	750 MHz	OK
3846	Body 850MHz	Oct.25,2014	850 MHz	OK
3846	Body 900MHz	Oct.26,2014	900 MHz	OK
3846	Body 1750MHz	Oct.27,2014	1750 MHz	OK
3846	Body 1810MHz	Oct.27,2014	1810 MHz	OK
3846	Body 1900MHz	Oct.28,2014	1900 MHz	OK
3846	Body 1950MHz	Oct.28,2014	1950 MHz	OK
3846	Body 2000MHz	Oct.28,2014	2000 MHz	OK
3846	Body 2100MHz	Oct.28,2014	2100 MHz	OK
3846	Body 2300MHz	Oct.29,2014	2300 MHz	OK
3846	Body 2450MHz	Oct.29,2014	2450 MHz	OK
3846	Body 2550MHz	Oct.29,2014	2550 MHz	OK
3846	Body 2600MHz	Oct.29,2014	2600 MHz	OK
3846	Body 3500MHz	Oct.30,2014	3500 MHz	OK
3846	Body 3700MHz	Oct.30,2014	3700 MHz	OK
3846	Body 5200MHz	Oct.24,2014	5200 MHz	OK
3846	Body 5500MHz	Oct.24,2014	5500 MHz	OK
3846	Body 5800MHz	Oct.24,2014	5800 MHz	OK

ANNEX G Probe Calibration Certificate

Probe 3846 Calibration Certificate

Calibration Laboratory of
Schmid & Partner
Engineering AG
Zeughausstrasse 43, 8004 Zurich, Switzerland



S Schweizerischer Kalibrierdienst
S Service suisse d'étalonnage
S Servizio svizzero di taratura
S Swiss Calibration Service

Accredited by the Swiss Accreditation Service (SAS)
The Swiss Accreditation Service is one of the signatories to the EA
Multilateral Agreement for the recognition of calibration certificates

Accreditation No.: SCS 108

Client **CTTL (Auden)**

Certificate No: **EX3-3846_Sep14**

CALIBRATION CERTIFICATE

Object **EX3DV4 - SN:3846**

Calibration procedure(s) **QA CAL-01.v9, QA CAL-14.v4, QA CAL-23.v5, QA CAL-25.v6
Calibration procedure for dosimetric E-field probes**



Calibration date: **September 24, 2014**

This calibration certificate documents the traceability to national standards, which realize the physical units of measurements (SI).
The measurements and the uncertainties with confidence probability are given on the following pages and are part of the certificate.

All calibrations have been conducted in the closed laboratory facility: environment temperature (22 ± 3)°C and humidity < 70%.

Calibration Equipment used (M&TE critical for calibration)

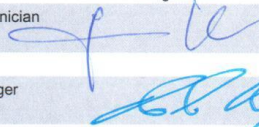
Primary Standards	ID	Cal Date (Certificate No.)	Scheduled Calibration
Power meter E4419B	GB41293874	03-Apr-14 (No. 217-01911)	Apr-15
Power sensor E4412A	MY41498087	03-Apr-14 (No. 217-01911)	Apr-15
Reference 3 dB Attenuator	SN: S5054 (3c)	03-Apr-14 (No. 217-01915)	Apr-15
Reference 20 dB Attenuator	SN: S5277 (20x)	03-Apr-14 (No. 217-01919)	Apr-15
Reference 30 dB Attenuator	SN: S5129 (30b)	03-Apr-14 (No. 217-01920)	Apr-15
Reference Probe ES3DV2	SN: 3013	30-Dec-13 (No. ES3-3013_Dec13)	Dec-14
DAE4	SN: 660	13-Dec-13 (No. DAE4-660_Dec13)	Dec-14
Secondary Standards	ID	Check Date (in house)	Scheduled Check
RF generator HP 8648C	US3642U01700	4-Aug-99 (in house check Apr-13)	In house check: Apr-16
Network Analyzer HP 8753E	US37390585	18-Oct-01 (in house check Oct-13)	In house check: Oct-14

Calibrated by:	Name Jeton Kastrati	Function Laboratory Technician	Signature 
Approved by:	Name Katja Pokovic	Function Technical Manager	Signature 

Issued: September 24, 2014

This calibration certificate shall not be reproduced except in full without written approval of the laboratory.

**Calibration Laboratory of
Schmid & Partner
Engineering AG**
Zeughausstrasse 43, 8004 Zurich, Switzerland

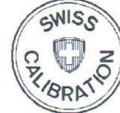

S Schweizerischer Kalibrierdienst
C Service suisse d'étalonnage
S Servizio svizzero di taratura
S Swiss Calibration Service

Accredited by the Swiss Accreditation Service (SAS)

Accreditation No.: **SCS 108**

The Swiss Accreditation Service is one of the signatories to the EA
Multilateral Agreement for the recognition of calibration certificates

Glossary:

TSL	tissue simulating liquid
NORM _{x,y,z}	sensitivity in free space
ConvF	sensitivity in TSL / NORM _{x,y,z}
DCP	diode compression point
CF	crest factor (1/duty_cycle) of the RF signal
A, B, C, D	modulation dependent linearization parameters
Polarization φ	φ rotation around probe axis
Polarization ϑ	ϑ rotation around an axis that is in the plane normal to probe axis (at measurement center), i.e., $\vartheta = 0$ is normal to probe axis
Connector Angle	information used in DASY system to align probe sensor X to the robot coordinate system

Calibration is Performed According to the Following Standards:

- IEEE Std 1528-2013, "IEEE Recommended Practice for Determining the Peak Spatial-Averaged Specific Absorption Rate (SAR) in the Human Head from Wireless Communications Devices: Measurement Techniques", June 2013
- IEC 62209-1, "Procedure to measure the Specific Absorption Rate (SAR) for hand-held devices used in close proximity to the ear (frequency range of 300 MHz to 3 GHz)", February 2005

Methods Applied and Interpretation of Parameters:

- NORM_{x,y,z}**: Assessed for E-field polarization $\vartheta = 0$ ($f \leq 900$ MHz in TEM-cell; $f > 1800$ MHz: R22 waveguide). NORM_{x,y,z} are only intermediate values, i.e., the uncertainties of NORM_{x,y,z} does not affect the E^2 -field uncertainty inside TSL (see below ConvF).
- NORM(f)_{x,y,z}** = NORM_{x,y,z} * frequency_response (see Frequency Response Chart). This linearization is implemented in DASY4 software versions later than 4.2. The uncertainty of the frequency response is included in the stated uncertainty of ConvF.
- DCP_{x,y,z}**: DCP are numerical linearization parameters assessed based on the data of power sweep with CW signal (no uncertainty required). DCP does not depend on frequency nor media.
- PAR**: PAR is the Peak to Average Ratio that is not calibrated but determined based on the signal characteristics
- A_{x,y,z}; B_{x,y,z}; C_{x,y,z}; D_{x,y,z}; VR_{x,y,z}**: A, B, C, D are numerical linearization parameters assessed based on the data of power sweep for specific modulation signal. The parameters do not depend on frequency nor media. VR is the maximum calibration range expressed in RMS voltage across the diode.
- ConvF and Boundary Effect Parameters**: Assessed in flat phantom using E-field (or Temperature Transfer Standard for $f \leq 800$ MHz) and inside waveguide using analytical field distributions based on power measurements for $f > 800$ MHz. The same setups are used for assessment of the parameters applied for boundary compensation (alpha, depth) of which typical uncertainty values are given. These parameters are used in DASY4 software to improve probe accuracy close to the boundary. The sensitivity in TSL corresponds to NORM_{x,y,z} * ConvF whereby the uncertainty corresponds to that given for ConvF. A frequency dependent ConvF is used in DASY version 4.4 and higher which allows extending the validity from ± 50 MHz to ± 100 MHz.
- Spherical isotropy (3D deviation from isotropy)**: in a field of low gradients realized using a flat phantom exposed by a patch antenna.
- Sensor Offset**: The sensor offset corresponds to the offset of virtual measurement center from the probe tip (on probe axis). No tolerance required.
- Connector Angle**: The angle is assessed using the information gained by determining the NORM_x (no uncertainty required).



EX3DV4 – SN:3846

September 24, 2014

Probe EX3DV4

SN:3846

Manufactured: October 25, 2011
Calibrated: September 24, 2014

Calibrated for DASY/EASY Systems
(Note: non-compatible with DASY2 system!)

EX3DV4- SN:3846

September 24, 2014

DASY/EASY - Parameters of Probe: EX3DV4 - SN:3846

Basic Calibration Parameters

	Sensor X	Sensor Y	Sensor Z	Unc (k=2)
Norm ($\mu\text{V}/(\text{V}/\text{m})^2$) ^A	0.39	0.42	0.49	± 10.1 %
DCP (mV) ^B	103.8	100.3	98.5	

Modulation Calibration Parameters

UID	Communication System Name		A dB	B dB $\sqrt{\mu\text{V}}$	C	D dB	VR mV	Unc ^E (k=2)
0	CW	X	0.0	0.0	1.0	0.00	141.2	±3.8 %
		Y	0.0	0.0	1.0		146.9	
		Z	0.0	0.0	1.0		139.6	

The reported uncertainty of measurement is stated as the standard uncertainty of measurement multiplied by the coverage factor k=2, which for a normal distribution corresponds to a coverage probability of approximately 95%.

^A The uncertainties of NormX,Y,Z do not affect the E²-field uncertainty inside TSL (see Pages 5 and 6).

^B Numerical linearization parameter: uncertainty not required.

^E Uncertainty is determined using the max. deviation from linear response applying rectangular distribution and is expressed for the square of the field value.