







# Quick Start Guide







\*\*\*\*\*

## Safety and use

---

We recommend that you read this chapter carefully before using this device. The manufacturer disclaims any liability for damage, which may result as a consequence of improper use of this device or of use contrary to the instructions contained herein.

	Do not switch on your device when its use is prohibited or when using the device may cause interference or danger.
	Follow rules or regulations in hospitals and health care facilities. Switch off your device near medical apparatus.
	Switch off your device in an aircraft. The device may cause interference to aircraft control signals.
	Switch off your device near high-precision electronic devices. The device may affect the performance of these devices.
	Do not attempt to disassemble your device or its accessories. Only qualified personnel are allowed to service or repair the device.

	Do not place your device or its accessories in containers with a strong electromagnetic field.
	Do not place magnetic storage media near your device. Radiation from the device may erase the information stored on them.
	Do not subject your device to high temperatures or use it in a place with flammable gas such as a petrol station.
	Keep your device and its accessories away from children. Do not allow children to use your device without guidance.
	Only use approved batteries and chargers to avoid the risk of explosion.
	Observe the laws or regulations on device use. Respect others' privacy and legal rights when using your device.







It is recommended that the equipment only be used in an environment where the temperature is between  $-10^{\circ}\text{C}$  and  $50^{\circ}\text{C}$  and humidity is between 10% to 90%.

# 1. Overview

---

ALCATEL ONE TOUCH LINK Y850 is a portable wireless router, providing a simple way to share 4G with any Wi-Fi embedded device.

## 1.1 Package contents

- ONE TOUCH Y850 
- USB cable 
- Quick start guide 
- USB Wall charger 
- Car Charger\* 
- USB Adapter\* 
- USB Cradle charger \* 

**Note:** \*depending on your region and market.

## 1.2 Application



## 1.3 Device overview

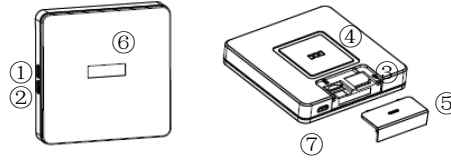

Number	Description
①	Power on/off Key
②	WPS Key
③	Reboot Button
④	Charging Pin*
⑤	SIM Card Cover
⑥	OLED screen
⑦	Micro USB Interface

**Note:** \*depending on your region and market

Use the device's 3 buttons as follows:

Button	Description
① <b>Power On/Off</b>	Long press to turn on/off the device
	Short press to put the OLED screen in either active or sleep mode.
② <b>WPS</b>	Long press to turn on WPS
	Short press to display SSID and password
③ <b>Reboot</b>	Long press to reboot the device if the system freezes.

## 1.4 Turning on the device

**Step 1: Push down on the SIM Card cover and install your SIM card as indicated on the device.**

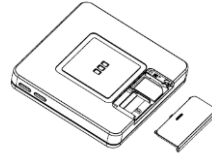
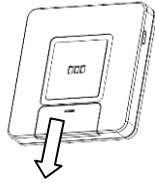

**Step 2: Press the Power On/Off button**





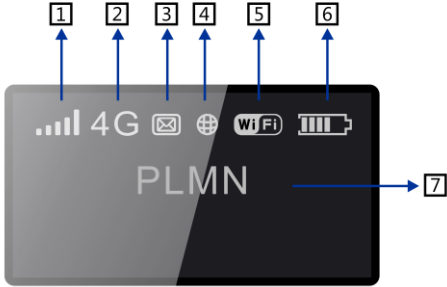

## 1.5 Screen display



















The screen display is interpreted as follows:



1	Network Signal (dynamic graphic symbol )
2	Network type (4G/H+/3G/2G)
3	SMS status (full, unread, incoming)
4	Connection status(connected and disconnected )
5	Wi-Fi (number of user connected/WPS connection)
6	Battery level (dynamic graphic symbol when charging)
7	Name of the network registered

Screen description:

Category	Icon Display
Signal Strength	 From 1 bar to excellent signal strength
Network type	2G: EDGE/GPRS 3G: UMTS/HSDPA/HSUPA,H+: HSPA+,4G:LTE
SMS status	 : SMS is available  : Unread SMS  : SMS full
Connection Status	 connected

Wi-Fi status	 : Wi-Fi is active           : Number of Wi-Fi users  : WPS is active  : WPS connected successfully  : WPS connection failed
Battery	    : From 1 level to level 4  : Low power

**Note: the information is displayed for 20 seconds, then the display powers off. You can reactivate the display with a short press on the Power key.**

## 1.6 Connecting in Wi-Fi mode

**SSID** : locate the SSID information on the sticker on the SIM card cover.

**Step 1:** Use the Wi-Fi manager on the Wi-Fi embedded device to select network name (SSID).

◆ From a Windows PC: Right-click **Wireless network connection** on the task bar, and select:

View Available Networks.

Choose SSID from the list of available networks.

◆ From a Mac computer: Select System Preferences -> Network->Airport. Click "Advanced" to choose SSID from the list of available networks.

◆ From an iOS device: Settings->Wi-Fi. Choose SSID from the available networks.

◆ From an android device: Settings->Wireless controls->Wi-Fi settings. Choose SSID from the available networks.

**Step 2:** Enter the Wi-Fi key when prompted for a security key.

## 2. Quick Setup

---

Open your browser, and input the address <http://192.168.1.1> to access the login page.

Default login password: **admin**

Login and click "Quick Setup" to configure the basic settings.

### Admin Password:

- **Login Password:** Set the password for login.

### Wi-Fi Settings:

- **SSID:** Set the network name of this device.
- **Security:** Configure the security mode for Wi-Fi connection.

### 3. Charging the device

---

You have many ways to charge your device - the magnetic attraction of the device ensures that the ALCATEL ONETOUCH LINK Y850 maintains close contact with your Wall Charger/Cradle\*/Adapter\*.

#### Wall Charger charging:

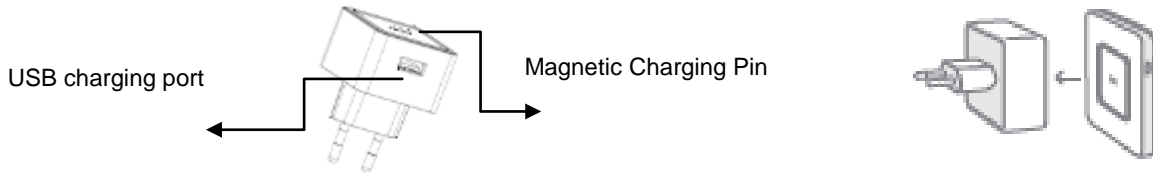

Option1: Plug Wall Charger into power socket and put the ALCATEL ONETOUCH LINK Y850 on wall charger. Lightly rotate the device to ensure it is securely located in the slot. Charging will then begin.

Option 2: Plug Wall Charger into power socket, plug the USB cable into the USB charging port on the Wall Charger, then connect the

ALCATEL ONETOUCH LINK Y850 by USB cable. Charging will then begin.

When the device is powered off, charging will take a maximum of 3 hours.

### **USB Cable charging**

You can also charge the device by connecting it to a PC with the USB cable.

When the device is powered off, charging will take a maximum of 4 hours.

### **Cradle charging\***

Connect the USB cable with the Cradle and put the ALCATEL ONETOUCH LINK Y850 on the Cradle. Lightly rotate the device to ensure it is securely located in the slot. Charging will then begin.

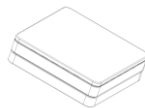

## Car charging\*

Assemble Car Charger and Adapter as below, and plug into the cigarette lighter port of the Car. Place the ALCATEL ONETOUCH LINK Y850 on the Adapter and lightly rotate the device to ensure it is securely located in the slot. Charging will then begin.



**Note1:** \*depending on your region and market.

**Note2:** In order to protect the battery, when low power  is indicated, please charge the device.



## **4. Certification**

---

### WEEE Approval

This device is in compliance with the essential requirements and other relevant provisions of the Waste Electrical and Electronic Equipment Directive 2002/96/EC (WEEE Directive).

### RoHs Approval

This device is in compliance with the restriction of the use of certain hazardous substances in electrical and electronic equipment Directive 2002/95/EC (RoHs Directive).

## **FCC Regulations**

This device complies with part 15 of the FCC Rules. Operation is subject to the following two conditions: (1) This device may not cause harmful interference, and (2) this device must accept any interference received, including interference that may cause undesired operation.

This device has been tested and found to comply with the limits for a Class B digital device, pursuant to Part 15 of the FCC Rules. These limits are designed to provide reasonable protection against harmful interference in a residential installation. This equipment generates, uses and can radiated radio frequency energy and, if not installed and used in accordance with the instructions, may cause harmful interference to radio communications. However, there is no guarantee that interference will not occur in a particular installation. If this equipment does cause harmful interference to radio or television reception, which can be determined by turning the equipment off and on, the user is encouraged to try to correct the interference by one or more of the following measures:

-Reorient or relocate the receiving antenna.

-Increase the separation between the equipment and receiver.

-Connect the equipment into an outlet on a circuit different from that to which the receiver is connected.

-Consult the dealer or an experienced radio/TV technician for help.

Caution: Changes or modifications not expressly approved by the party responsible for compliance could void the user's authority to operate the equipment.

### **FCC RF Exposure Information (SAR)**

This device is designed and manufactured not to exceed the emission limits for exposure to radio frequency (RF) energy set by the Federal Communications Commission of the United States.

During SAR testing, this device is set to transmit at its highest certified power level in all tested frequency bands, and placed in positions that simulate RF exposure in usage near the body with the separation of 5 mm. Although the SAR is determined at the highest certified power level, the actual SAR level of the device while operating can be well below the maximum value. This is because the device is designed to operate at multiple power levels so as to use only the power required to reach the network. In general, the closer you are to a wireless base station antenna, the lower the power output.

The exposure standard for wireless s employs a unit of measurement known as the Specific Absorption Rate, or SAR. The SAR limit set by the FCC is 1.6W/kg.

Tests for SAR are conducted using standard operating positions accepted by the FCC with the device transmitting at its highest certified power level in all tested frequency bands.

The FCC has granted an Equipment Authorization for this model device with all reported SAR levels evaluated as in compliance with the FCC RF exposure guidelines. SAR information on this model device is on file with the FCC and can be found under the Display Grant section of [www.fcc.gov/oet/ea/fccid](http://www.fcc.gov/oet/ea/fccid) after searching on FCC ID: RAD522.

For this device, the highest reported SAR value for usage near the body is 1.30 W/kg.

SAR compliance for body operation is based on a separation distance of 5 mm between the unit and the human body.

The World Health Organization (WHO) considers that present scientific information does not indicate the need for any special precautions for use of modem. If individuals are concerned, they might choose to limit their own or their children's RF exposure by limiting the length of use to keep data card away from the head and body. (fact sheet n°193) Additional WHO information about electromagnetic fields and public health are available on the following website: <http://www.who.int/peh-emf>.

This device is equipped with a built-in antenna. For optimal operation, you should avoid touching it or degrading it.

For more information you can go to [www.alcatelonetouch.com/usa/](http://www.alcatelonetouch.com/usa/)

Alcatel is a trademark of Alcatel-Lucent used under license by TCT Mobile Limited.

All rights reserved © 2010-2012 TCT Mobile Limited.

Address: Room 1910-12A, Tower 3, China HK City, 33 Canton Road, Tsimshatsui, Kowloon, Hong Kong