



# SAR TEST REPORT

No. I14Z47754-SEM01

For

**TCT Mobile Limited**

**GSM Quad-band / UMTS Quad-band / LTE 6 bands mobile phone**

**Model name: 8030B**

With

**Hardware Version: BAB33S001DCX**

**Software Version: vE1Z**

**FCC ID: RAD492**

**Issued Date: 2014-11-15**

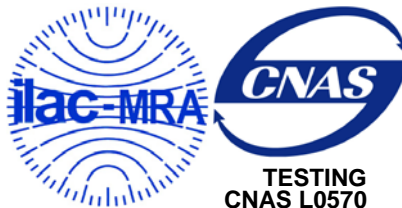

**Note:**

The test results in this test report relate only to the devices specified in this report. This report shall not be reproduced except in full without the written approval of CTTL.

**Test Laboratory:**

CTTL, Telecommunication Technology Labs, Academy of Telecommunication Research, MIIT

No.52, HuayuanNorth Road, Haidian District, Beijing, P. R. China 100191.

Tel:+86(0)10-62304633-2512,Fax:+86(0)10-62304633-2504

Email:[ctl\\_terminals@catr.cn](mailto:ctl_terminals@catr.cn), website:[www.chinattl.com](http://www.chinattl.com)



## **REPORT HISTORY**

<b>Report Number</b>	<b>Revision</b>	<b>Issue Date</b>	<b>Description</b>
I14Z47754-SEM01	Rev.0	2014-11-07	Initial creation of test report
I14Z47754-SEM01	Rev.1	2014-11-15	<ol style="list-style-type: none"><li>1. Add some SAR results of additional channels for WLAN in table 14.16 on page 60 and table 14.18 on page 61.</li><li>2. Revise the table 2.1 on page 6.</li><li>3. Revise the table 8.1 on page 23.</li><li>4. Revise the dielectric parameters in WLAN-5G body SAR plot on page 108.</li><li>5. Add the note in table 11.9 on page 35 to mark 16QAM uplink for HSPA+.</li><li>6. Revise the Fig 17-1 and 18-1 on page 107 and 109.</li></ol>



## TABLE OF CONTENT

<b>1 TEST LABORATORY</b> .....	<b>5</b>
1.1 TESTING LOCATION .....	5
1.2 TESTING ENVIRONMENT.....	5
1.3 PROJECT DATA .....	5
1.4 SIGNATURE.....	5
<b>2 STATEMENT OF COMPLIANCE</b> .....	<b>6</b>
<b>3 CLIENT INFORMATION</b> .....	<b>8</b>
3.1 APPLICANT INFORMATION .....	8
3.2 MANUFACTURER INFORMATION .....	8
<b>4 EQUIPMENT UNDER TEST (EUT) AND ANCILLARY EQUIPMENT (AE)</b> .....	<b>9</b>
4.1 ABOUT EUT .....	9
4.2 INTERNAL IDENTIFICATION OF EUT USED DURING THE TEST .....	9
4.3 INTERNAL IDENTIFICATION OF AE USED DURING THE TEST .....	9
4.4 ACCESSORY.....	10
<b>5 TEST METHODOLOGY</b> .....	<b>12</b>
5.1 APPLICABLE LIMIT REGULATIONS .....	12
5.2 APPLICABLE MEASUREMENT STANDARDS.....	12
<b>6 SPECIFIC ABSORPTION RATE (SAR)</b> .....	<b>13</b>
6.1 INTRODUCTION.....	13
6.2 SAR DEFINITION.....	13
<b>7 TISSUE SIMULATING LIQUIDS</b> .....	<b>14</b>
7.1 TARGETS FOR TISSUE SIMULATING LIQUID .....	14
7.2 DIELECTRIC PERFORMANCE .....	15
<b>8 SYSTEM VERIFICATION</b> .....	<b>22</b>
8.1 SYSTEM SETUP.....	22
8.2 SYSTEM VERIFICATION.....	23
<b>9 MEASUREMENT PROCEDURES</b> .....	<b>24</b>
9.1 TESTS TO BE PERFORMED .....	24
9.2 GENERAL MEASUREMENT PROCEDURE.....	25
9.3 WCDMA MEASUREMENT PROCEDURES FOR SAR .....	26
9.4 SAR MEASUREMENT FOR LTE.....	27
9.5 BLUETOOTH & WI-FI MEASUREMENT PROCEDURES FOR SAR .....	28
9.6 POWER DRIFT.....	28
<b>10 AREA SCAN BASED 1-G SAR</b> .....	<b>29</b>
10.1 REQUIREMENT OF KDB.....	29
10.2 FAST SAR ALGORITHMS .....	29



<b>11 CONDUCTED OUTPUT POWER</b> .....	<b>30</b>
11.1 MANUFACTURING TOLERANCE .....	30
11.2 GSM MEASUREMENT RESULT .....	34
11.3 WCDMA MEASUREMENT RESULT.....	35
11.4 LTE MEASUREMENT RESULT .....	36
11.6 WI-FI AND BT MEASUREMENT RESULT .....	44
<b>12 SIMULTANEOUS TX SAR CONSIDERATIONS</b> .....	<b>47</b>
12.1 INTRODUCTION.....	47
12.2 TRANSMIT ANTENNA SEPARATION DISTANCES .....	47
12.3 SAR MEASUREMENT POSITIONS .....	47
12.4 STANDALONE SAR TEST EXCLUSION CONSIDERATIONS .....	48
<b>13 EVALUATION OF SIMULTANEOUS</b> .....	<b>49</b>
<b>14 SAR TEST RESULT</b> .....	<b>50</b>
14.1 SAR RESULTS FOR FAST SAR.....	50
14.2 SAR RESULTS FOR STANDARD PROCEDURE.....	63
<b>15 SAR MEASUREMENT VARIABILITY</b> .....	<b>68</b>
<b>16 MEASUREMENT UNCERTAINTY</b> .....	<b>69</b>
<b>17 MAIN TEST INSTRUMENTS</b> .....	<b>73</b>
<b>ANNEX A GRAPH RESULTS</b> .....	<b>74</b>
<b>ANNEX B SYSTEM VERIFICATION RESULTS</b> .....	<b>110</b>
<b>ANNEX C SAR MEASUREMENT SETUP</b> .....	<b>129</b>
<b>ANNEX D POSITION OF THE WIRELESS DEVICE IN RELATION TO THE PHANTOM</b> .....	<b>135</b>
<b>ANNEX E EQUIVALENT MEDIA RECIPES</b> .....	<b>138</b>
<b>ANNEX F SYSTEM VALIDATION</b> .....	<b>139</b>
<b>ANNEX G PROBE CALIBRATION CERTIFICATE</b> .....	<b>140</b>
<b>ANNEX H DIPOLE CALIBRATION CERTIFICATE</b> .....	<b>151</b>

## 1 Test Laboratory

### 1.1 Testing Location

Company Name:	CTTL(huayuan North Road)
Address:	No. 52, Huayuan North Road, Haidian District, Beijing, P. R. China 100191

### 1.2 Testing Environment

Temperature:	18°C~25 °C,
Relative humidity:	30%~ 70%
Ground system resistance:	< 0.5 $\Omega$
Ambient noise & Reflection:	< 0.012 W/kg

### 1.3 Project Data

Project Leader:	Qi Dianyuan
Test Engineer:	Lin Xiaojun
Testing Start Date:	October 13, 2014
Testing End Date:	October 31, 2014

### 1.4 Signature



Lin Xiaojun  
(Prepared this test report)

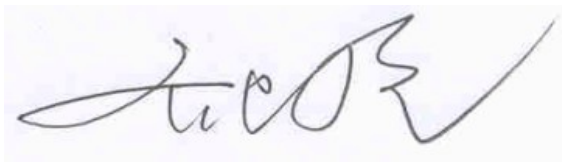

Qi Dianyuan  
(Reviewed this test report)



Xiao Li  
Deputy Director of the laboratory  
(Approved this test report)

## 2 Statement of Compliance

The maximum results of SAR found during testing for TCT Mobile Limited GSM Quad-band / UMTS Quad-band / LTE 6 bands mobile phone 8030B are as follows:

**Table 2.1: Highest Reported SAR (1g)**

Exposure Configuration	Technology Band	Highest Reported SAR 1g (W/Kg)	Equipment Class
Head (Separation Distance 0mm)	GSM 850	0.23	PCE
	PCS 1900	0.18	
	UMTS FDD 2	0.24	
	UMTS FDD 5	0.21	
	LTE Band 2	0.13	
	LTE Band 4	0.24	
	LTE Band 7	0.43	
	WLAN 2.4 GHz	0.83	DTS
	WLAN 5 GHz	1.10	UNII
Body-worn (Data) (Separation Distance 10mm)	GSM 850	0.42	PCE
	PCS 1900	0.54	
	UMTS FDD 2	0.61	
	UMTS FDD 5	0.29	
	LTE Band 2	0.50	
	LTE Band 4	0.41	
	LTE Band 7	0.98	
	WLAN 2.4 GHz	0.21	DTS
	WLAN 5 GHz	0.27	UNII

The SAR values found for the Mobile Phone are below the maximum recommended levels of 1.6 W/Kg as averaged over any 1g tissue according to the ANSI C95.1-1999.

For body worn operation, this device has been tested and meets FCC RF exposure guidelines when used with any accessory that contains no metal and which provides a minimum separation distance of 10 mm between this device and the body of the user. Use of other accessories may not ensure compliance with FCC RF exposure guidelines.

The EUT battery must be fully charged and checked periodically during the test to ascertain uniform power output.

The measurement together with the test system set-up is described in annex C of this test report. A detailed description of the equipment under test can be found in chapter 4 of this test report.

The highest reported SAR value is obtained at the case of **(Table 2.1)**, and the values are: **1.10 W/kg (1g)**.

**Table 2.2: The sum of reported SAR values for main antenna and WiFi**

	Position	Main antenna	WiFi	Sum
<b>Maximum reported SAR value for Head</b>	Left hand, Touch cheek	0.43	1.05	<b>1.48</b>
	Left hand, Tilt 15°	0.16	1.10	<b>1.26</b>
<b>Maximum reported SAR value for Body</b>	Front	0.98	0.15	<b>1.13</b>
	Top	/	0.27	/

**Table 2.3: The sum of reported SAR values for main antenna and BT**

	Position	Main antenna	BT	Sum
<b>Maximum reported SAR value for Head</b>	Left hand, Touch cheek	0.43	0.26 <sup>[1]</sup>	<b>0.69</b>
<b>Maximum reported SAR value for Body</b>	Front	0.98	0.13 <sup>[1]</sup>	<b>1.11</b>

[1] - Estimated SAR for Bluetooth (see the table 13.3)

According to the above tables, the highest sum of reported SAR values is **1.48 W/kg (1g)**. The detail for simultaneous transmission consideration is described in chapter 13.

Because the display diagonal dimension is > 15.0cm, the phone is phablet. So it has to be estimated as follow:

According to the KDB648474 D04, when hotspot mode applies, 10-g extremity SAR is required only for the surfaces and edges with hotspot mode 1-g reported SAR > 1.2 W/kg.

**Table 2.4: Highest Reported SAR (10g extremity)**

Technology Band	Test Position	Conducted Power (dBm)	Max. tune-up Power (dBm)	Highest Measured SAR(1g) (W/kg)	Highest Reported SAR 1g (W/Kg)	Highest Reported SAR 10g extremity (W/Kg)
GSM 850	Rear	31.10	31.3	0.399	0.42	/
PCS 1900	Bottom	28.29	28.3	0.536	0.54	/
UMTS FDD 2	Rear	23.27	24.0	0.513	0.61	/
UMTS FDD 5	Rear	23.50	24.0	0.255	0.29	/
LTE Band 2	Rear	23.38	23.5	0.487	0.50	/
LTE Band 4	Rear	23.39	23.5	0.396	0.41	/
LTE Band 7	Front	22.88	23.0	0.958	0.98	/
WLAN 2.4&5.8 GHz	Top	12.34	13.0	0.201	0.23	/
WLAN 5.0 GHz	Top	12.56	13.0	0.241	0.27	/

According to the above tables, the Highest Reported SAR for 10g extremity is < exposure limits (4.0W/kg).



### 3 Client Information

#### 3.1 Applicant Information

Company Name:	TCT Mobile Limited
Address /Post:	5F, C building, No. 232, Liang Jing Road ZhangJiang High-Tech Park, Pudong Area Shanghai, P.R. China. 201203
City:	Shanghai
Postal Code:	201203
Country:	China
Contact Person:	Gong Zhizhou
E-mail:	zhizhou.gong@tcl.com
Telephone:	0086-21-51798260
Fax:	0086-21-61460602

#### 3.2 Manufacturer Information

Company Name:	TCT Mobile Limited
Address /Post:	5F, C building, No. 232, Liang Jing Road ZhangJiang High-Tech Park, Pudong Area Shanghai, P.R. China. 201203
City:	Shanghai
Postal Code:	201203
Country:	China
Contact Person:	Gong Zhizhou
E-mail:	zhizhou.gong@tcl.com
Telephone:	0086-21-51798260
Fax:	0086-21-61460602



## 4 Equipment Under Test (EUT) and Ancillary Equipment (AE)

### 4.1 About EUT

Description:	GSM Quad-band / UMTS Quad-band / LTE 6 bands mobile phone
Model name:	8030B
Operating mode(s):	GSM 850/900/1800/1900, WCDMA 850/900/1900/2100 BT, Wi-Fi (2.4G&5G), LTE Band 1/2/3/4/7/28
Tested Tx Frequency:	825 – 848.8 MHz (GSM 850)
	1850.2 – 1910 MHz (GSM 1900)
	826.4–846.6 MHz (WCDMA 850 Band V)
	1852.4–1907.6 MHz (WCDMA1900 Band II)
	1860 – 1900 MHz (LTE Band 2)
	1720 – 1745 MHz (LTE Band 4)
	2502.5 – 2567.5 MHz (LTE Band 7)
	2412 – 2462 MHz (Wi-Fi 2.4G)
	5180 – 5825 MHz (Wi-Fi 5G)
GPRS/EGPRS Multislot Class:	12
GPRS capability Class:	B
Test device Production information:	Production unit
Device type:	Portable device
Antenna type:	Integrated antenna
Accessories/Body-worn configurations:	Headset
Hotspot mode:	Support simultaneous transmission of hotspot and voice(or data)
Form factor:	160.5 mm × 81.6 mm

### 4.2 Internal Identification of EUT used during the test

EUT ID*	IMEI	HW	SW Version
EUT1	014107000900040	BAB33S001DCX	vE1Z
EUT2	014107000900024	BAB33S001DCX	vE1Z
EUT3	014107000900032	BAB33S001DCX	vE1Z
EUT4	014107000900313	BAB33S001DCX	vE1Z

\*EUT ID: is used to identify the test sample in the lab internally.

**Note:** It is performed to test SAR with the EUT1/2/3 and conducted power with the EUT4.

### 4.3 Internal Identification of AE used during the test

AE ID*	Description	Model	SN	Manufacturer
AE1	Battery	CAC3100002C2	/	SCUD
AE2	Headset	CCA0001A10C9	/	JBL
AE3	Headset	CCB3001A15C4	/	Meihao

\*AE ID: is used to identify the test sample in the lab internally.

#### 4.4 Accessory

There are three kinds of accessory (flip cover) with conductive materials, the details is presented in the below picture 1-1. We'll perform the head measurement in all bands without the accessory and retest on highest value point with the accessory in each band. Then, repeat the measurement in the Body test.

### Magic Flip LED Matrix CMF

Dark Grey

Size: 158x 80.8x2.4mm Deco Thickness: 3.0mm Flip Cover Thickness: 2.9mm

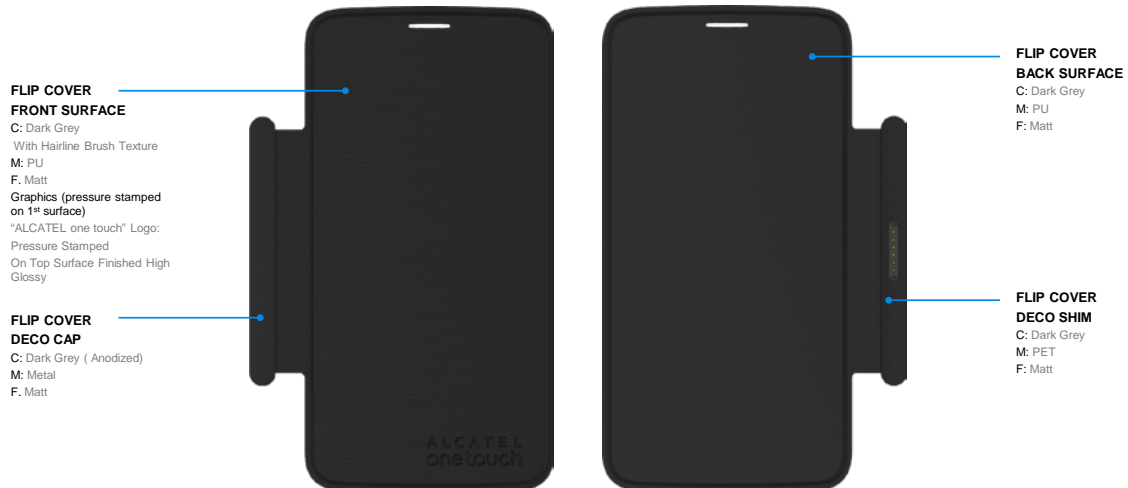

ALCATEL  
onetouch.

### Magic Flip Kick Stand CMF

Dark Grey

Size: 158x 80.8x1.6mm Flip Deco Thickness: 2.6mm Flip Cover Thickness: 2.3mm

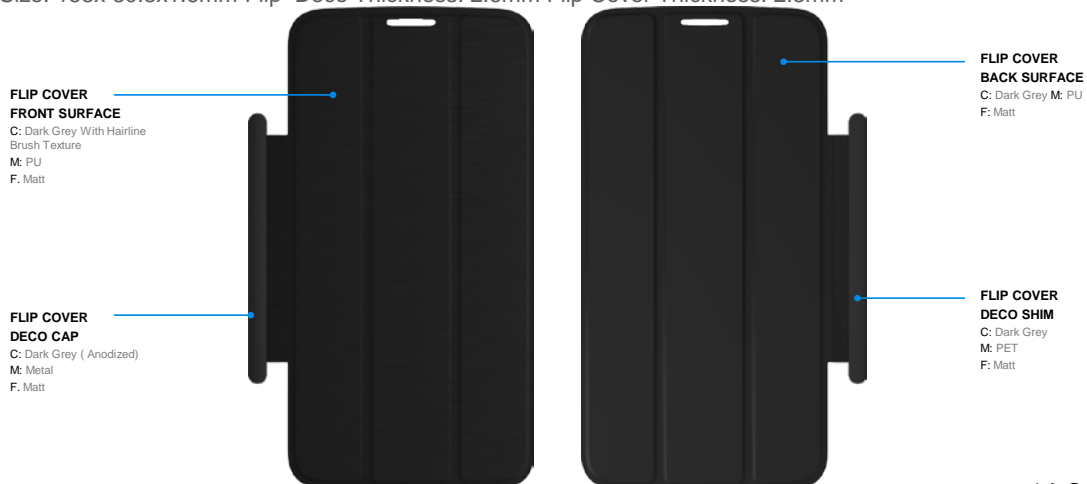

ALCATEL  
onetouch.

## Magic Flip Window CMF

Dark Grey

Size: 158x 80.8x1.8mm Deco Thickness :2.6mm Flip Cover Thickness: 2.0mm

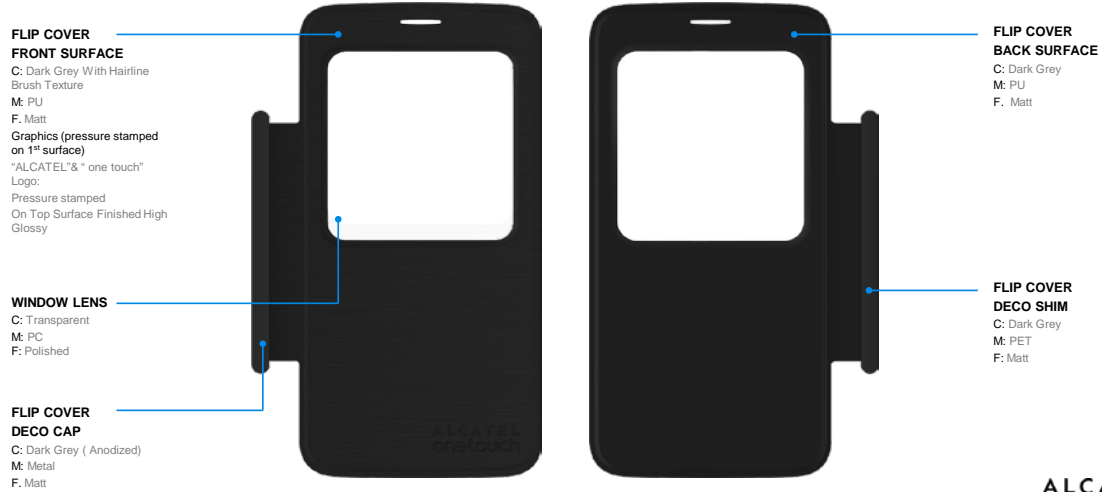

ALCATEL  
onetouch.

Picture 1-1: Constituents of the flip cover

**Note: We use the number 1, 2, 3 to replace the Flip cover name for SAR test results in chapter 15.**

**"1" is Magic Flip LED Matrix CMF**

**"2" is Magic Flip Kick Stand CMF**

**"3" is Magic Flip Window CMF**

## 5 TEST METHODOLOGY

### 5.1 Applicable Limit Regulations

**ANSI C95.1–1999:** IEEE Standard for Safety Levels with Respect to Human Exposure to Radio Frequency Electromagnetic Fields, 3 kHz to 300 GHz.

It specifies the maximum exposure limit of **1.6 W/kg** as averaged over any 1 gram of tissue for portable devices being used within 20 cm of the user in the uncontrolled environment.

### 5.2 Applicable Measurement Standards

**IEEE 1528–2003:** Recommended Practice for Determining the Peak Spatial-Average Specific Absorption Rate (SAR) in the Human Body Due to Wireless Communications Devices: Experimental Techniques.

**KDB447498 D01: General RF Exposure Guidance v05r02:** Mobile and Portable Devices RF Exposure Procedures and Equipment Authorization Policies.

**KDB648474 D04 Handset SAR v01r02:** SAR Evaluation Considerations for Wireless Handsets.

**KDB941225 D01 SAR test for 3G devices v02:** SAR Measurement Procedures for 3G Devices

**KDB941225 D05 SAR for LTE Devices v02r03:** SAR Evaluation Considerations for LTE Devices

**KDB941225 D06 Hotspot Mode SAR v01r01:** SAR Evaluation Procedures for Portable Devices with Wireless Router Capabilities

**KDB248227 D01 SAR meas for 802 11 a b g v01r02 :** SAR measurement procedures for 802.112abg transmitters.

**KDB 865664 D01 SAR measurement 100 MHz to 6 GHz v01r03:** SAR Measurement Requirements for 100 MHz to 6 GHz.

**KDB 865664 D02 RF Exposure Reporting v01r01:** RF Exposure Compliance Reporting and Documentation Considerations

## 6 Specific Absorption Rate (SAR)

### 6.1 Introduction

SAR is related to the rate at which energy is absorbed per unit mass in an object exposed to a radio field. The SAR distribution in a biological body is complicated and is usually carried out by experimental techniques or numerical modeling. The standard recommends limits for two tiers of groups, occupational/controlled and general population/uncontrolled, based on a person's awareness and ability to exercise control over his or her exposure. In general, occupational/controlled exposure limits are higher than the limits for general population/uncontrolled.

### 6.2 SAR Definition

The SAR definition is the time derivative (rate) of the incremental energy ( $dW$ ) absorbed by (dissipated in) an incremental mass ( $dm$ ) contained in a volume element ( $dv$ ) of a given density ( $\rho$ ). The equation description is as below:

$$SAR = \frac{d}{dt} \left( \frac{dW}{dm} \right) = \frac{d}{dt} \left( \frac{dW}{\rho dv} \right)$$

SAR is expressed in units of Watts per kilogram (W/kg)

SAR measurement can be either related to the temperature elevation in tissue by

$$SAR = c \left( \frac{\delta T}{\delta t} \right)$$

Where:  $C$  is the specific heat capacity,  $\delta T$  is the temperature rise and  $\delta t$  is the exposure duration, or related to the electrical field in the tissue by

$$SAR = \frac{\sigma |E|^2}{\rho}$$

Where:  $\sigma$  is the conductivity of the tissue,  $\rho$  is the mass density of tissue and  $E$  is the RMS electrical field strength.

However for evaluating SAR of low power transmitter, electrical field measurement is typically applied.

## 7 Tissue Simulating Liquids

### 7.1 Targets for tissue simulating liquid

**Table 7.1: Targets for tissue simulating liquid**

Frequency(MHz)	Liquid Type	Conductivity( $\sigma$ )	$\pm 5\%$ Range	Permittivity( $\epsilon$ )	$\pm 5\%$ Range
835	Head	0.90	0.86~0.95	41.5	39.4~43.6
835	Body	0.97	0.92~1.02	55.2	52.4~58.0
1750	Head	1.37	1.30~1.44	40.08	38.1~42.1
1750	Body	1.49	1.42~1.56	53.4	50.7~56.1
1900	Head	1.40	1.33~1.47	40.0	38.0~42.0
1900	Body	1.52	1.44~1.60	53.3	50.6~56.0
2450	Head	1.80	1.71~1.89	39.2	37.2~41.2
2450	Body	1.95	1.85~2.05	52.7	50.1~55.3
2600	Head	1.96	1.86~2.06	39.01	37.06~40.96
2600	Body	2.16	2.05~2.27	52.5	49.9~55.1
5200	Head	4.66	4.43~4.89	35.99	34.19~37.79
5200	Body	5.30	5.04~5.56	49.0	46.6~51.4
5300	Head	4.76	4.52~5.00	35.87	34.08~37.66
5300	Body	5.42	5.15~5.69	48.9	46.46~51.34
5600	Head	5.07	4.82~5.32	35.53	33.75~37.31
5600	Body	5.77	5.48~6.06	48.5	46.08~50.92
5800	Head	5.27	5.01~5.53	35.3	33.5~37.1
5800	Body	6.00	5.70~6.30	48.2	45.8~50.6

## 7.2 Dielectric Performance

Table 7.2: Dielectric Performance of Tissue Simulating Liquid

Measurement Date (yyyy-mm-dd)	Type	Frequency	Permittivity $\epsilon$	Drift (%)	Conductivity $\sigma$ (S/m)	Drift (%)
2014-10-14	Head	835 MHz	42.46	2.31	0.918	2.00
	Body	835 MHz	56.4	2.17	0.968	-0.21
2014-10-15	Head	1750 MHz	40.95	2.17	1.388	1.31
	Body	1750 MHz	54.7	2.43	1.469	-1.41
2014-10-23	Head	1900 MHz	39.5	-1.25	1.386	-1.00
	Body	1900 MHz	54.81	2.83	1.544	1.58
2014-10-13	Head	2450 MHz	38.73	-1.20	1.818	1.00
	Body	2450 MHz	53.42	1.37	1.965	0.77
2014-10-16	Head	2600 MHz	39.27	0.67	1.98	1.02
	Body	2600 MHz	52.68	0.34	2.174	0.65
2014-10-31	Head	5200 MHz	36.54	1.53	4.507	-3.28
	Body	5200 MHz	48.36	-1.31	5.283	-0.32
2014-10-31	Head	5300 MHz	36.36	1.37	4.598	-3.40
	Body	5300 MHz	48.15	-1.53	5.432	0.22
2014-10-31	Head	5600 MHz	35.86	0.93	4.914	-3.08
	Body	5600 MHz	47.48	-2.10	5.846	1.32
2014-10-31	Head	5800 MHz	35.52	0.62	5.123	-2.79
	Body	5800 MHz	46.98	-2.53	6.173	2.88

Note: The liquid temperature is 22.0 °C

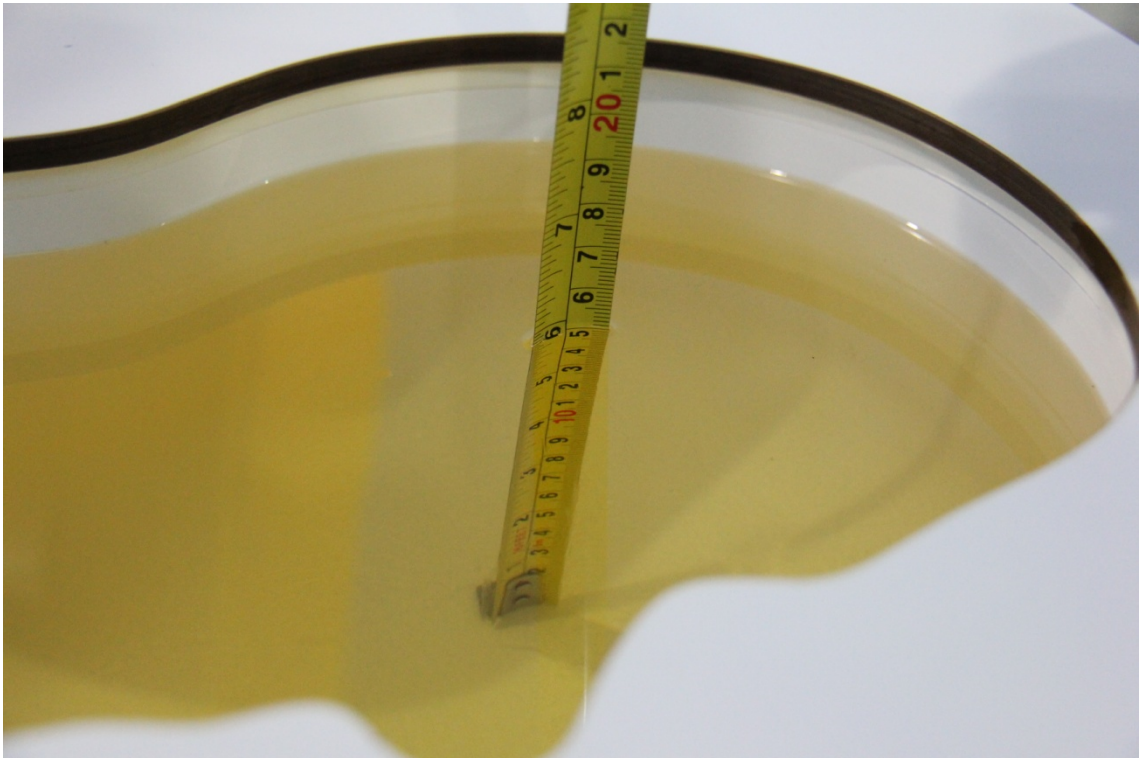

**Picture 7-1 Liquid depth in the Head Phantom (835 MHz)**



**Picture 7-2 Liquid depth in the Flat Phantom (835 MHz)**



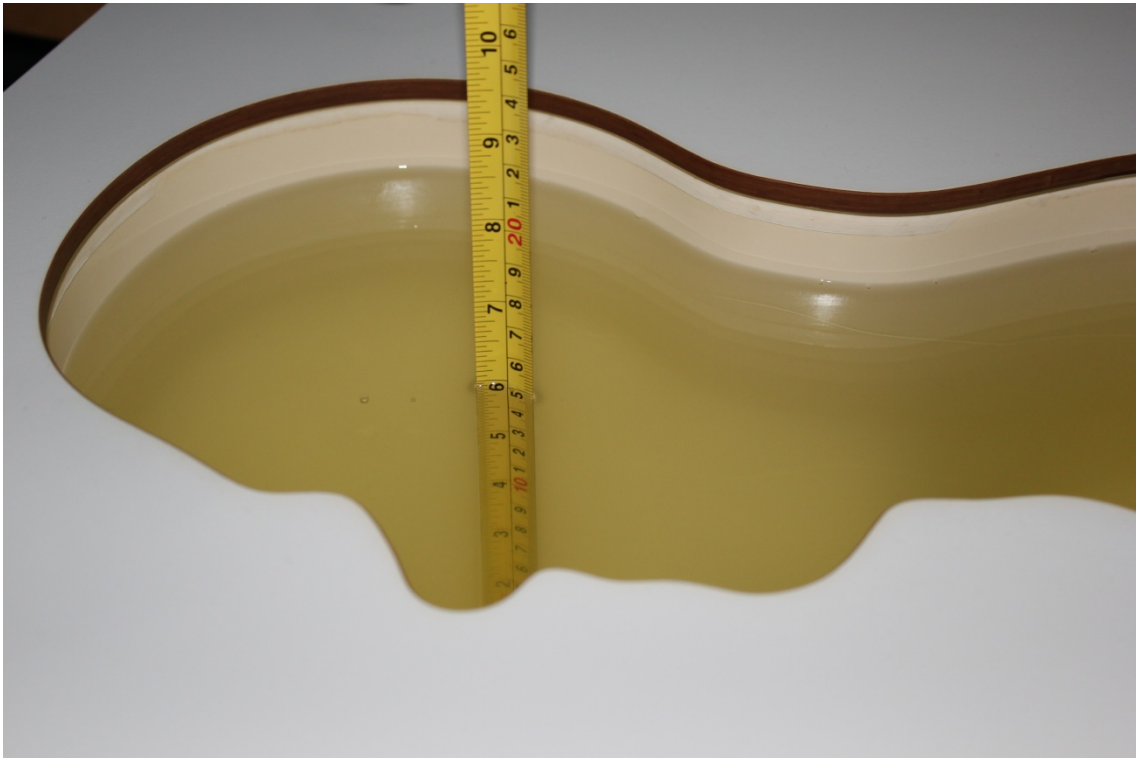

**Picture 7-3 Liquid depth in the Head Phantom (1750 MHz)**

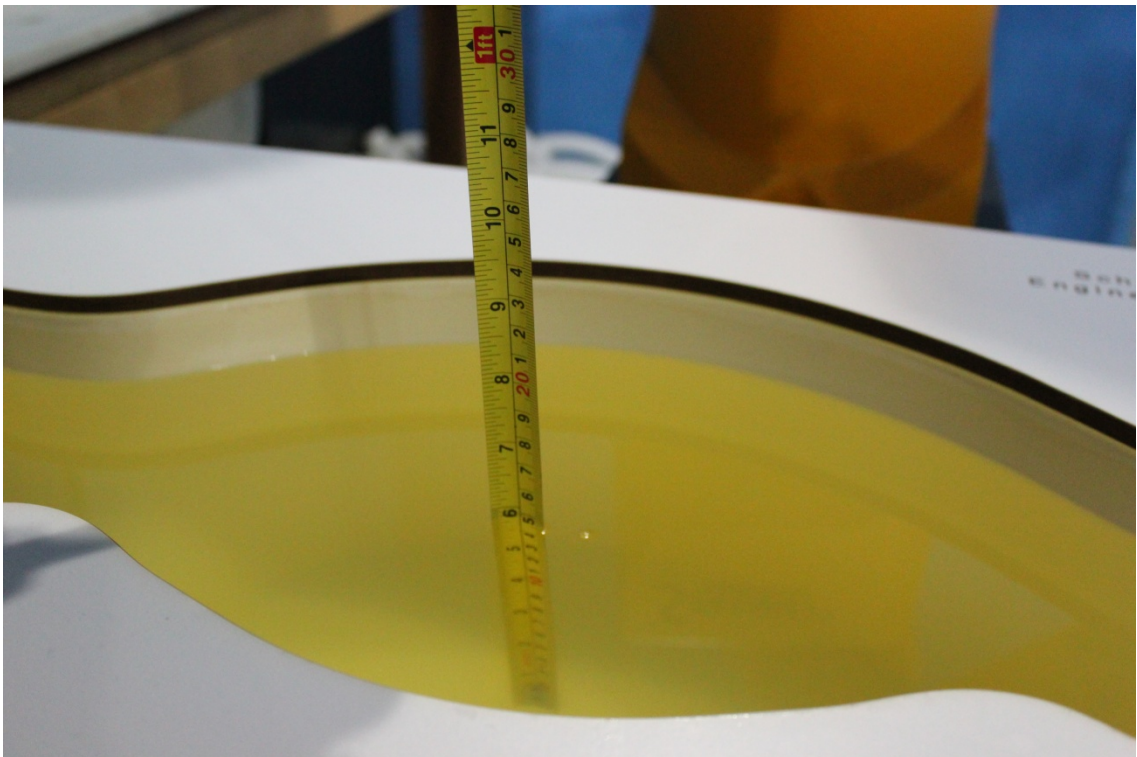

**Picture 7-4 Liquid depth in the Flat Phantom (1750MHz)**

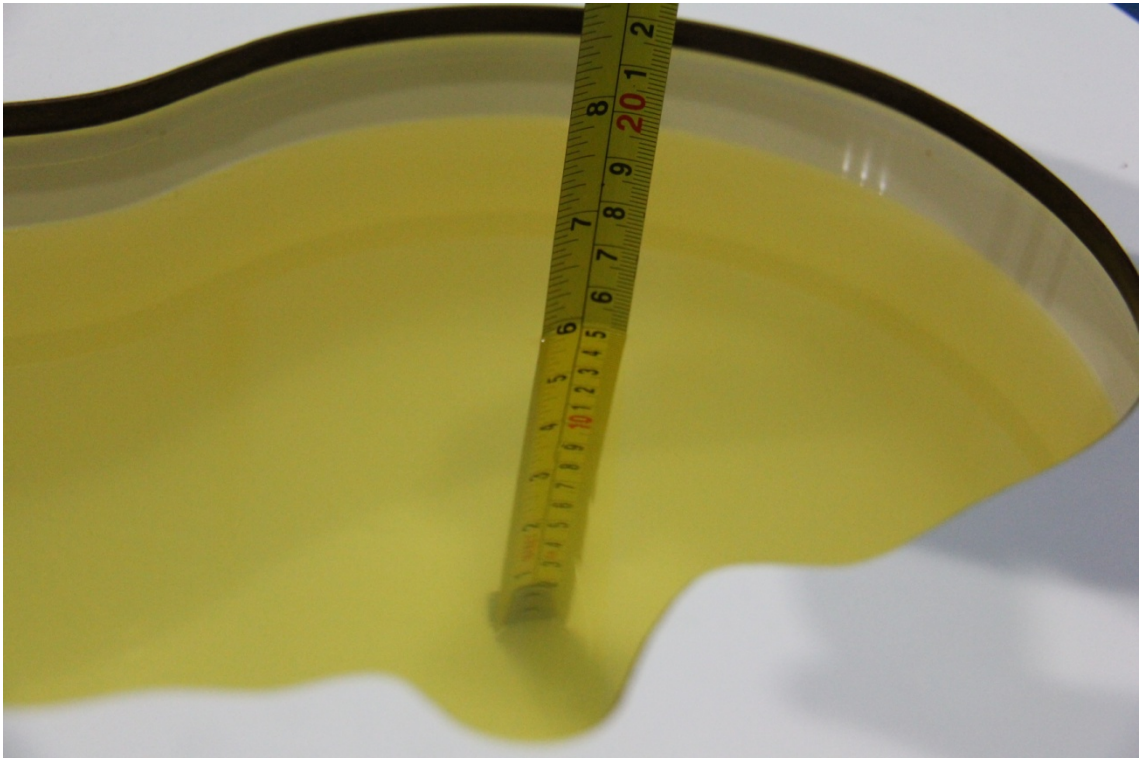

**Picture 7-5 Liquid depth in the Head Phantom (1900 MHz)**

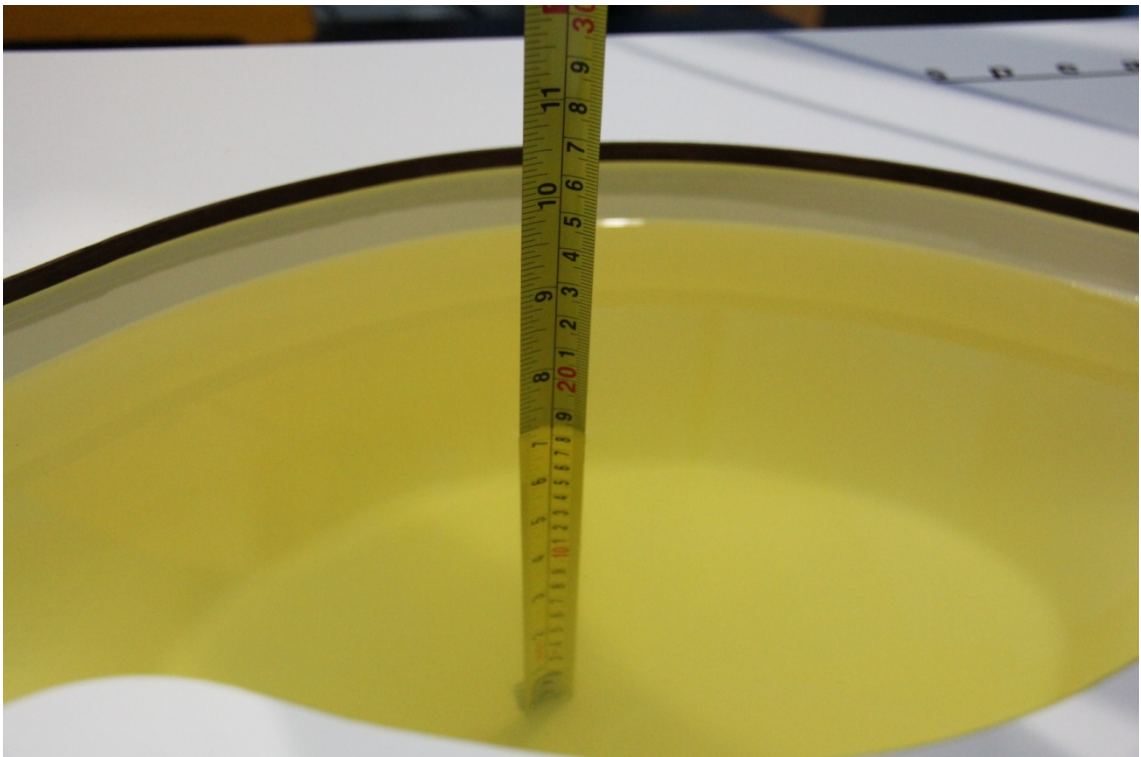

**Picture 7-6 Liquid depth in the Flat Phantom (1900MHz)**

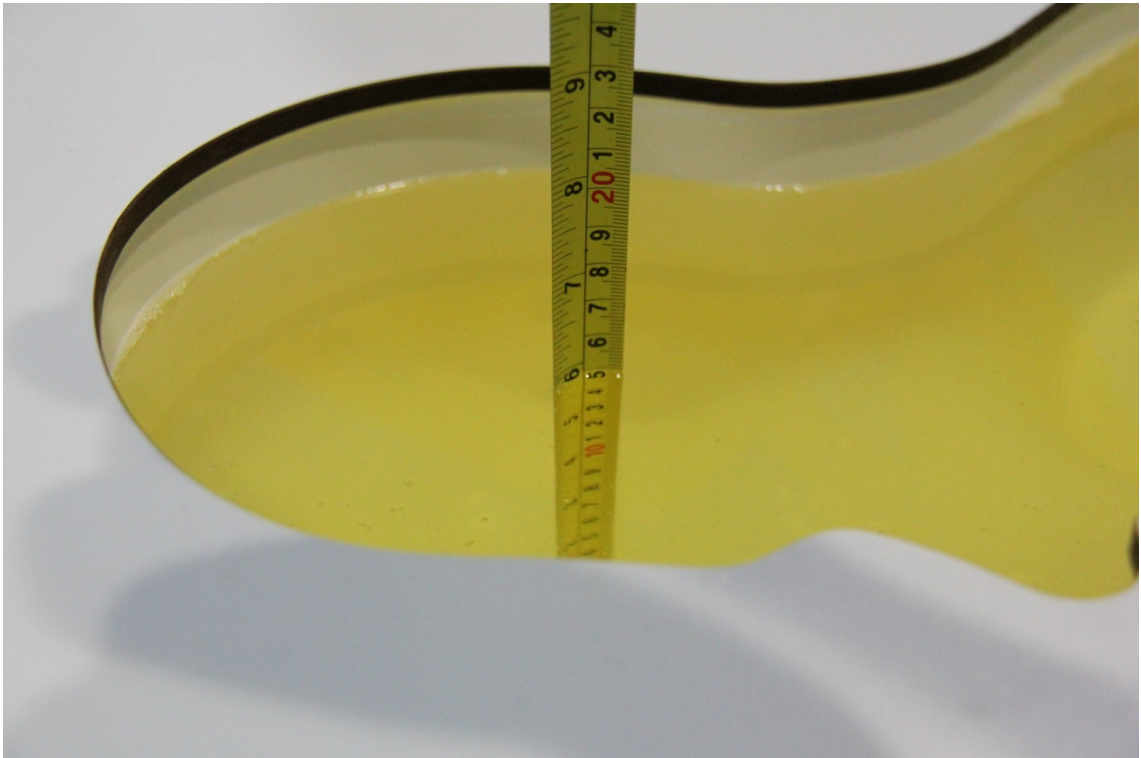

**Picture 7-7 Liquid depth in the Head Phantom (2450MHz)**

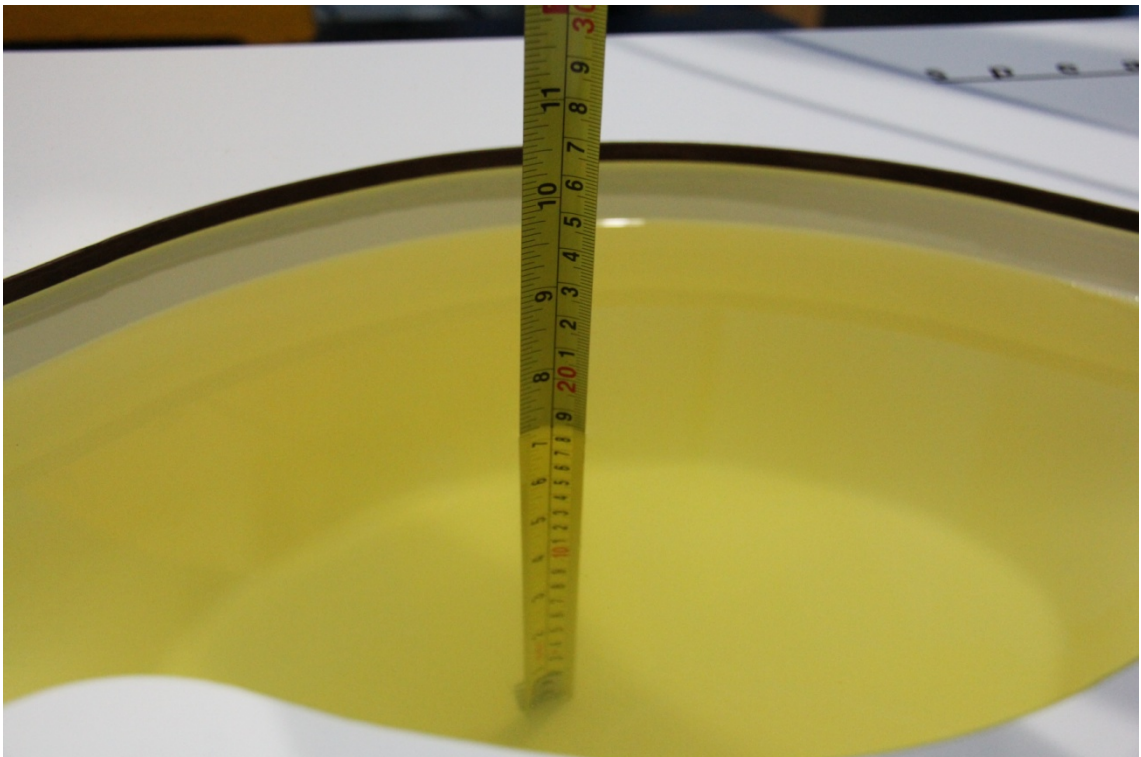

**Picture 7-8 Liquid depth in the Flat Phantom (2450MHz)**

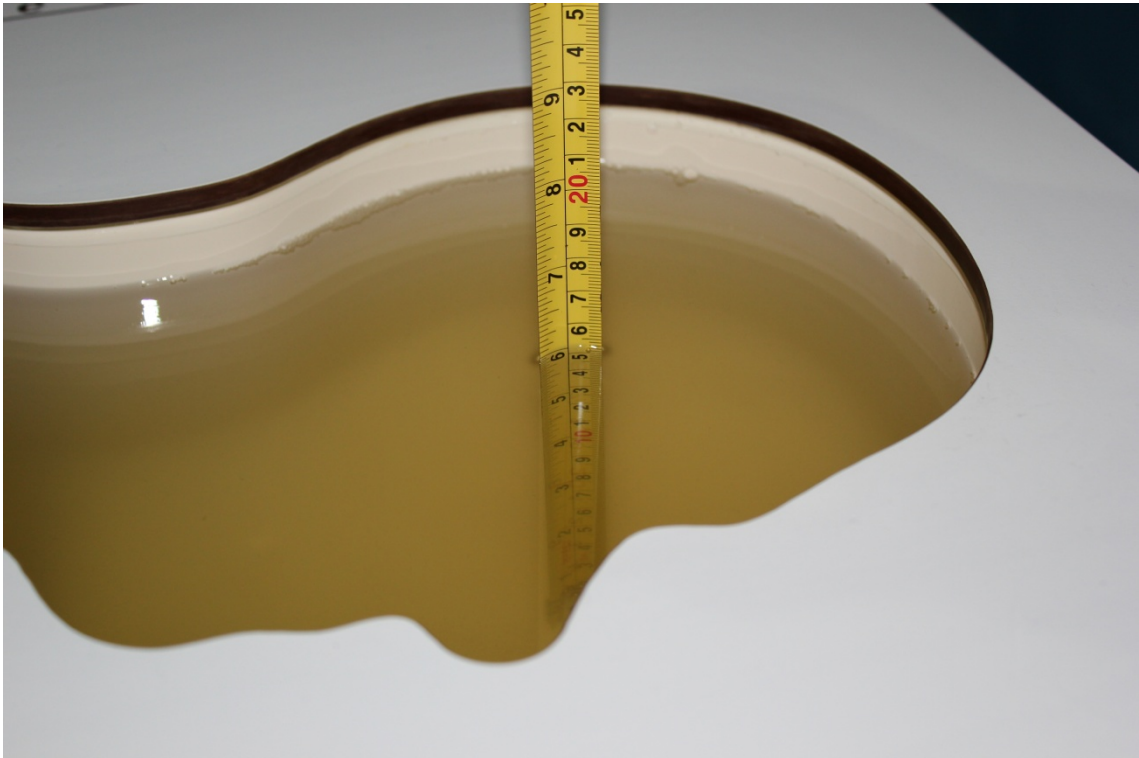

**Picture 7-9 Liquid depth in the Head Phantom (2600 MHz Head)**

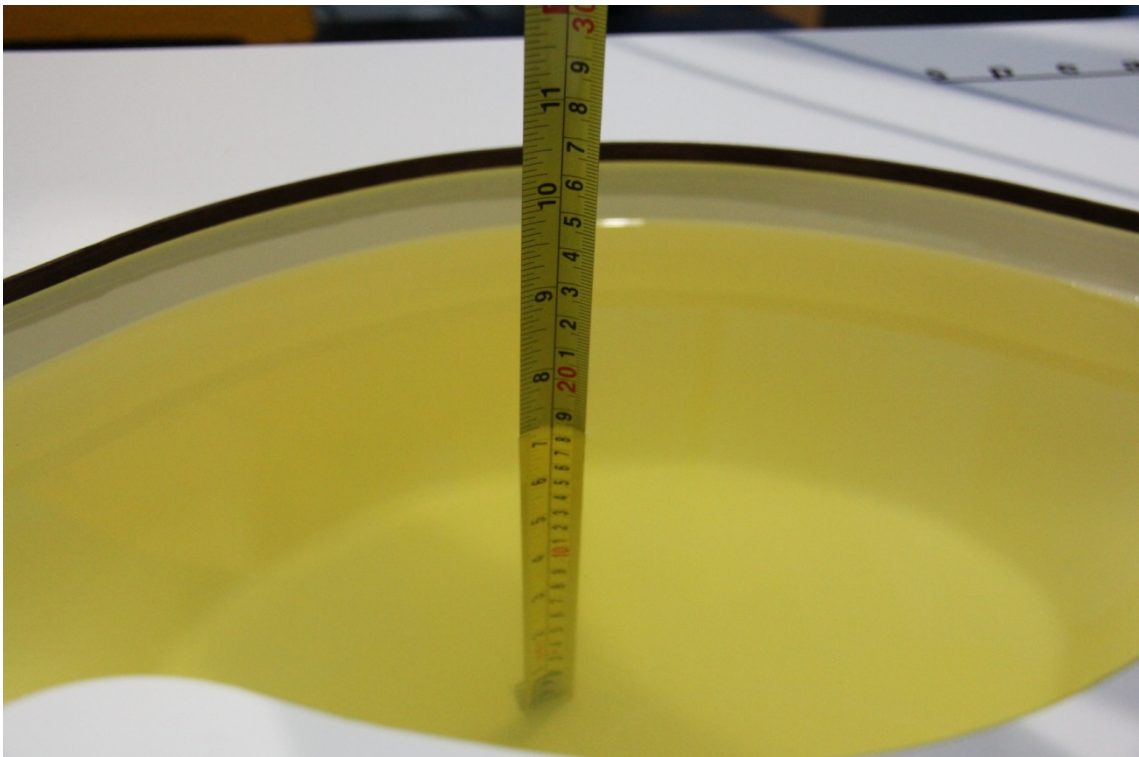

**Picture 7-10 Liquid depth in the Flat Phantom (2600MHz)**

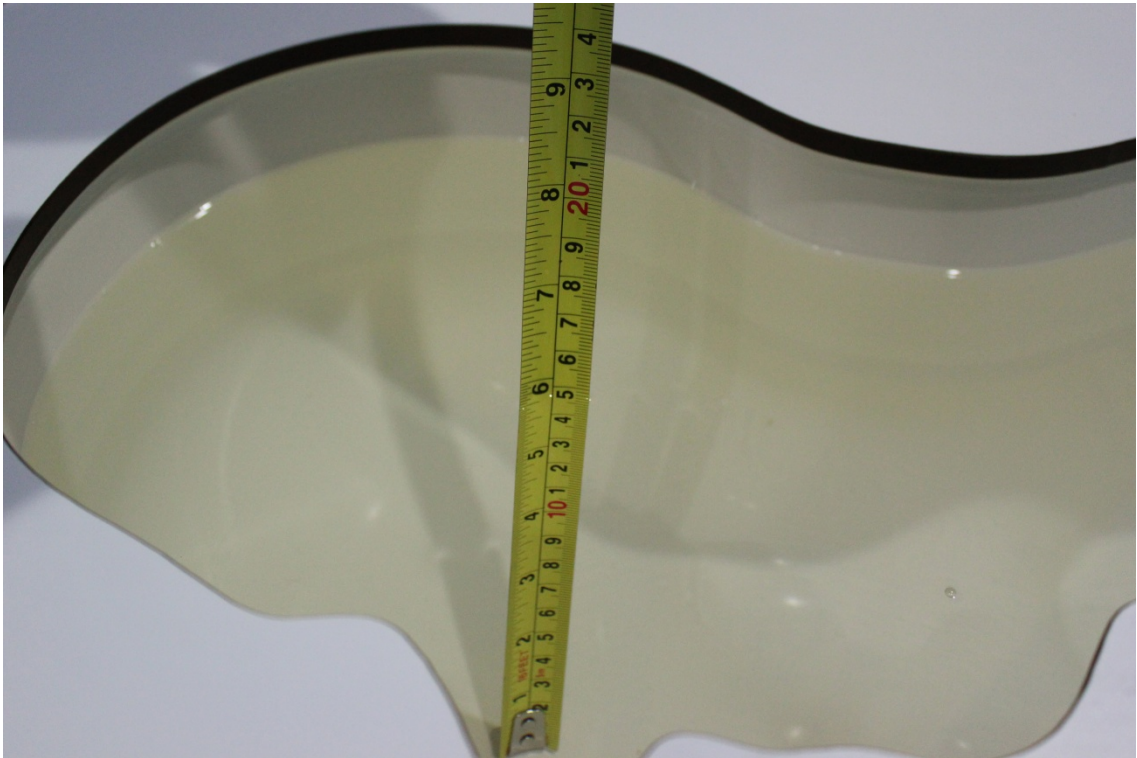

**Picture 7-11 Liquid depth in the Head Phantom (5GHz)**



**Picture 7-12 Liquid depth in the Flat Phantom (5GHz)**

## 8 System verification

### 8.1 System Setup

In the simplified setup for system evaluation, the DUT is replaced by a calibrated dipole and the power source is replaced by a continuous wave that comes from a signal generator. The calibrated dipole must be placed beneath the flat phantom section of the SAM twin phantom with the correct distance holder. The distance holder should touch the phantom surface with a light pressure at the reference marking and be oriented parallel to the long side of the phantom. The equipment setup is shown below:

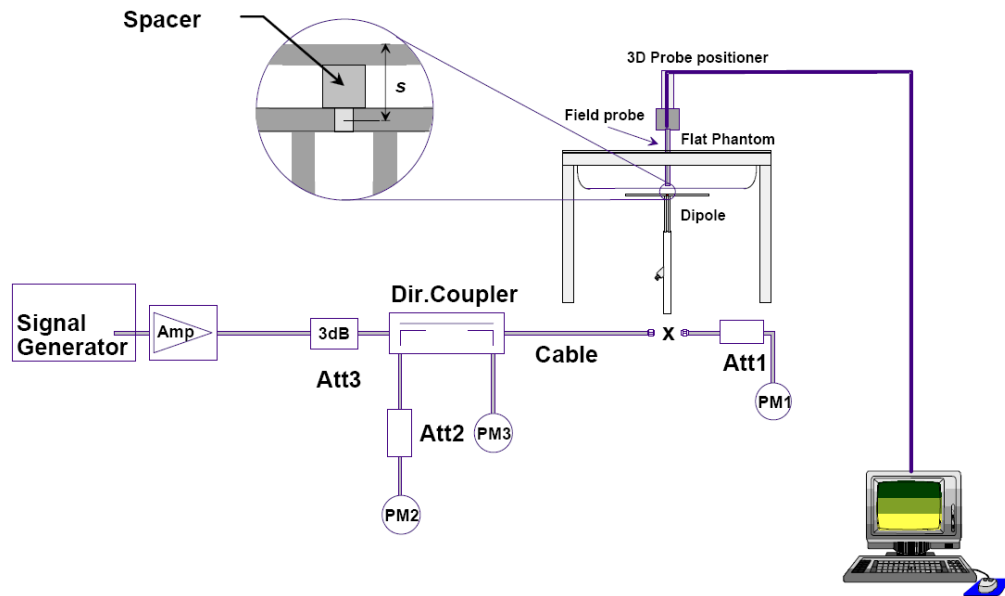

Picture 8.1 System Setup for System Evaluation

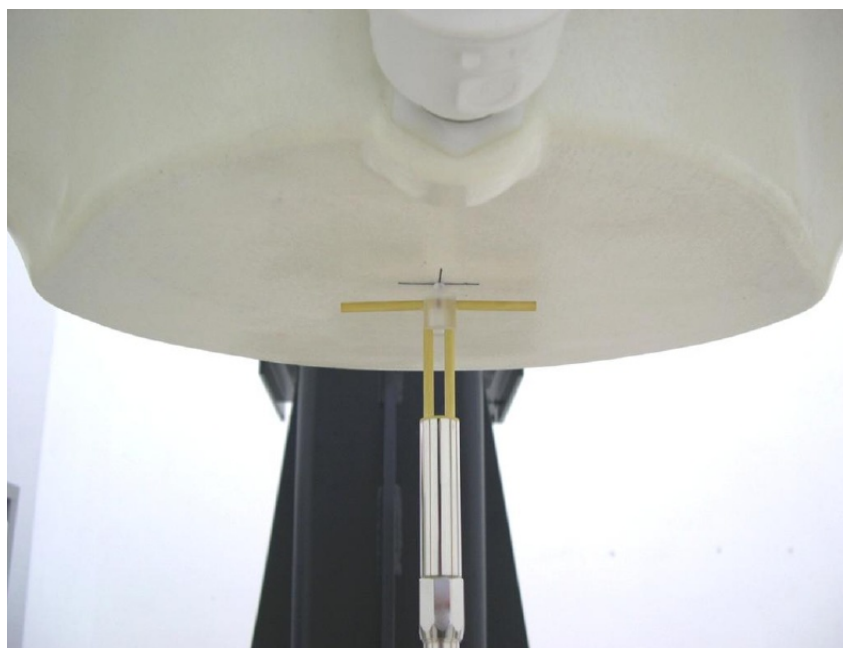

Picture 8.2 Photo of Dipole Setup

## 8.2 System Verification

SAR system verification is required to confirm measurement accuracy, according to the tissue dielectric media, probe calibration points and other system operating parameters required for measuring the SAR of a test device. The system verification must be performed for each frequency band and within the valid range of each probe calibration point required for testing the device.

The system verification results are required that the area scan estimated 1-g SAR is within 3% of the zoom scan 1-g SAR. The details are presented in annex B.

**Table 8.1: System Verification of Head**

Measurement Date (yyyy-mm-dd)	Frequency	Target value (W/kg)		Measured value (W/kg)		Deviation	
		10 g Average	1 g Average	10 g Average	1 g Average	10 g Average	1 g Average
2014-10-14	835 MHz	6.17	9.43	6.28	9.68	1.78%	2.65%
2014-10-15	1750 MHz	19.7	36.9	19.08	35.72	-3.15%	-3.20%
2014-10-23	1900 MHz	21.1	40.6	20.56	39.08	-2.56%	-3.74%
2014-10-13	2450 MHz	24.7	53.2	24.32	52.00	-1.54%	-2.26%
2014-10-16	2600 MHz	25.9	57.8	25.52	56.40	-1.47%	-2.42%
2014-10-31	5200 MHz	23.1	80.7	23.60	82.00	2.16%	1.61%
2014-10-31	5300 MHz	23.6	82.5	23.90	82.40	1.27%	-0.12%
2014-10-31	5600 MHz	24.3	85.3	24.10	84.90	-0.82%	-0.47%
2014-10-31	5800 MHz	22.8	80.5	22.10	78.20	-3.07%	-2.86%

**Table 8.2: System Verification of Body**

Measurement Date (yyyy-mm-dd)	Frequency	Target value (W/kg)		Measured value (W/kg)		Deviation	
		10 g Average	1 g Average	10 g Average	1 g Average	10 g Average	1 g Average
2014-10-14	835 MHz	6.33	9.55	6.20	9.40	-2.05%	-1.57%
2014-10-15	1750 MHz	20.3	37.7	19.96	37.12	-1.67%	-1.54%
2014-10-23	1900 MHz	21.4	40.4	21.28	40.80	-0.56%	0.99%
2014-10-13	2450 MHz	23.9	51.3	23.24	49.60	-2.76%	-3.31%
2014-10-16	2600 MHz	25.4	57.2	25.92	58.00	2.05%	1.40%
2014-10-31	5200 MHz	21.7	77.5	21.20	74.60	-2.30%	-3.74%
2014-10-31	5300 MHz	22.1	78.7	21.50	75.70	-2.71%	-3.81%
2014-10-31	5600 MHz	23.1	83.4	22.70	81.30	-1.73%	-2.52%
2014-10-31	5800 MHz	21.4	77.6	20.80	75.30	-2.80%	-2.96%

## 9 Measurement Procedures

### 9.1 Tests to be performed

In order to determine the highest value of the peak spatial-average SAR of a handset, all device positions, configurations and operational modes shall be tested for each frequency band according to steps 1 to 3 below. A flowchart of the test process is shown in picture 9.1.

**Step 1:** The tests described in 9.2 shall be performed at the channel that is closest to the centre of the transmit frequency band ( $f_c$ ) for:

- a) all device positions (cheek and tilt, for both left and right sides of the SAM phantom, as described in annex D),
- b) all configurations for each device position in a), e.g., antenna extended and retracted, and
- c) all operational modes, e.g., analogue and digital, for each device position in a) and configuration in b) in each frequency band.

If more than three frequencies need to be tested according to 11.1 (i.e.,  $N_c > 3$ ), then all frequencies, configurations and modes shall be tested for all of the above test conditions.

**Step 2:** For the condition providing highest peak spatial-average SAR determined in Step 1, perform all tests described in 9.2 at all other test frequencies, i.e., lowest and highest frequencies. In addition, for all other conditions (device position, configuration and operational mode) where the peak spatial-average SAR value determined in Step 1 is within 3 dB of the applicable SAR limit, it is recommended that all other test frequencies shall be tested as well.

**Step 3:** Examine all data to determine the highest value of the peak spatial-average SAR found in Steps 1 to 2.



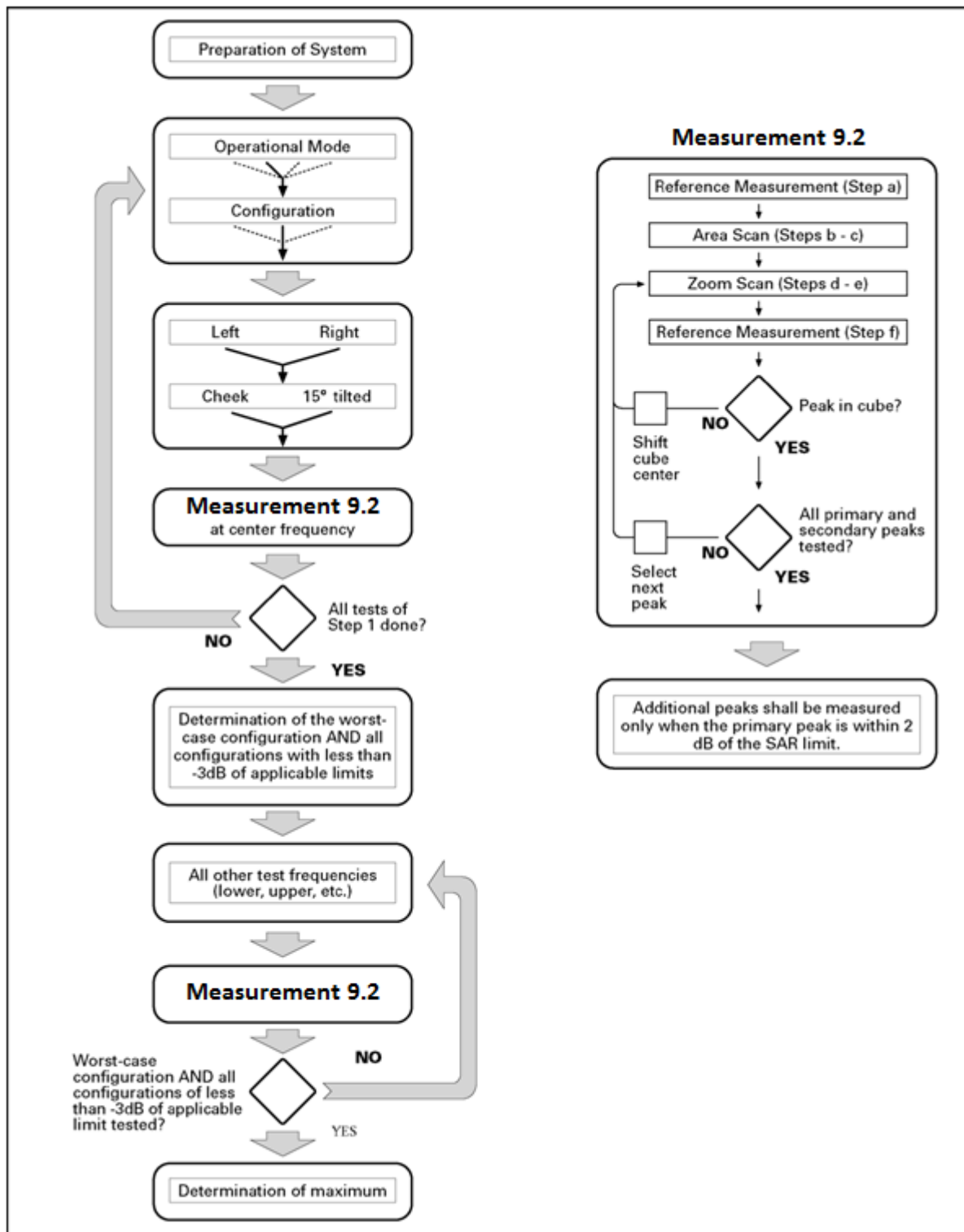

Picture 9.1 Block diagram of the tests to be performed

## 9.2 General Measurement Procedure

The area and zoom scan resolutions specified in the table below must be applied to the SAR measurements and fully documented in SAR reports to qualify for TCB approval. Probe boundary effect error compensation is required for measurements with the probe tip closer than half a probe

tip diameter to the phantom surface. Both the probe tip diameter and sensor offset distance must satisfy measurement protocols; to ensure probe boundary effect errors are minimized and the higher fields closest to the phantom surface can be correctly measured and extrapolated to the phantom surface for computing 1-g SAR. Tolerances of the post-processing algorithms must be verified by the test laboratory for the scan resolutions used in the SAR measurements, according to the reference distribution functions specified in IEEE Std 1528-2003. The results should be documented as part of the system validation records and may be requested to support test results when all the measurement parameters in the following table are not satisfied.

		$\leq 3$ GHz	$> 3$ GHz
Maximum distance from closest measurement point (geometric center of probe sensors) to phantom surface		$5 \pm 1$ mm	$\frac{1}{2} \cdot \delta \cdot \ln(2) \pm 0.5$ mm
Maximum probe angle from probe axis to phantom surface normal at the measurement location		$30^\circ \pm 1^\circ$	$20^\circ \pm 1^\circ$
Maximum area scan spatial resolution: $\Delta x_{Area}$ , $\Delta y_{Area}$		$\leq 2$ GHz: $\leq 15$ mm 2 – 3 GHz: $\leq 12$ mm	3 – 4 GHz: $\leq 12$ mm 4 – 6 GHz: $\leq 10$ mm
		When the x or y dimension of the test device, in the measurement plane orientation, is smaller than the above, the measurement resolution must be $\leq$ the corresponding x or y dimension of the test device with at least one measurement point on the test device.	
Maximum zoom scan spatial resolution: $\Delta x_{Zoom}$ , $\Delta y_{Zoom}$		$\leq 2$ GHz: $\leq 8$ mm 2 – 3 GHz: $\leq 5$ mm*	3 – 4 GHz: $\leq 5$ mm* 4 – 6 GHz: $\leq 4$ mm*
Maximum zoom scan spatial resolution, normal to phantom surface	uniform grid: $\Delta z_{Zoom}(n)$	$\leq 5$ mm	3 – 4 GHz: $\leq 4$ mm 4 – 5 GHz: $\leq 3$ mm 5 – 6 GHz: $\leq 2$ mm
	graded grid $\Delta z_{Zoom}(1)$ : between 1 <sup>st</sup> two points closest to phantom surface	$\leq 4$ mm	3 – 4 GHz: $\leq 3$ mm 4 – 5 GHz: $\leq 2.5$ mm 5 – 6 GHz: $\leq 2$ mm
	$\Delta z_{Zoom}(n>1)$ : between subsequent points	$\leq 1.5 \cdot \Delta z_{Zoom}(n-1)$	
Minimum zoom scan volume	x, y, z	$\geq 30$ mm	3 – 4 GHz: $\geq 28$ mm 4 – 5 GHz: $\geq 25$ mm 5 – 6 GHz: $\geq 22$ mm
<p>Note: <math>\delta</math> is the penetration depth of a plane-wave at normal incidence to the tissue medium; see draft standard IEEE P1528-2011 for details.</p> <p>* When zoom scan is required and the <i>reported</i> SAR from the area scan based 1-g SAR estimation procedures of KDB 447498 is <math>\leq 1.4</math> W/kg, <math>\leq 8</math> mm, <math>\leq 7</math> mm and <math>\leq 5</math> mm zoom scan resolution may be applied, respectively, for 2 GHz to 3 GHz, 3 GHz to 4 GHz and 4 GHz to 6 GHz.</p>			

### 9.3 WCDMA Measurement Procedures for SAR

The following procedures are applicable to WCDMA handsets operating under 3GPP Release99, Release 5 and Release 6. The default test configuration is to measure SAR with an established radio link between the DUT and a communication test set using a 12.2kbps RMC (reference measurement channel) configured in Test Loop Mode 1. SAR is selectively confirmed for other

physical channel configurations (DPCCH & DPDCH<sub>n</sub>), HSDPA and HSPA (HSUPA/HSDPA) modes according to output power, exposure conditions and device operating capabilities. Both uplink and downlink should be configured with the same RMC or AMR, when required. SAR for Release 5 HSDPA and Release 6 HSPA are measured using the applicable FRC (fixed reference channel) and E-DCH reference channel configurations. Maximum output power is verified according to applicable versions of 3GPP TS 34.121 and SAR must be measured according to these maximum output conditions. When Maximum Power Reduction (MPR) is not implemented according to Cubic Metric (CM) requirements for Release 6 HSPA, the following procedures do not apply.

**For Release 5 HSDPA Data Devices:**

Sub-test	$\beta_c$	$\beta_d$	$\beta_d$ (SF)	$\beta_c / \beta_d$	$\beta_{hs}$	CM/dB
1	2/15	15/15	64	2/15	4/15	0.0
2	12/15	15/15	64	12/15	24/25	1.0
3	15/15	8/15	64	15/8	30/15	1.5
4	15/15	4/15	64	15/4	30/15	1.5

**For Release 6 HSPA Data Devices**

Sub-test	$\beta_c$	$\beta_d$	$\beta_d$ (SF)	$\beta_c / \beta_d$	$\beta_{hs}$	$\beta_{ec}$	$\beta_{ed}$	$\beta_{ed}$ (SF)	$\beta_{ed}$ (codes)	CM (dB)	MPR (dB)	AG Index	E-TFCI
1	11/15	15/15	64	11/15	22/15	209/225	1039/225	4	1	3.0	3.0	20	75
2	6/15	15/15	64	6/15	12/15	12/15	12/15	4	1	3.0	3.0	12	67
3	15/15	9/15	64	15/9	30/15	30/15	$\beta_{ed1}:47/15$ $\beta_{ed2}:47/15$	4	2	2.0	2.0	15	92
4	2/15	15/15	64	2/15	4/15	4/15	56/75	4	1	3.5	3.5	17	71
5	15/15	15/15	64	15/15	24/15	30/15	134/15	4	1	1.0	1.0	21	81

**Rel.8 DC-HSDPA (Cat 24)**

SAR test exclusion for Rel.8 DC-HSDPA must satisfy the SAR test exclusion requirements of Rel.5 HSDPA. SAR test exclusion for DC-HSDPA devices is determined by power measurements according to the H-Set 12, Fixed Reference Channel (FRC) configuration in Table C.8.1.12 of 3GPP TS 34.121-1. A primary and a secondary serving HS-DSCH Cell are required to perform the power measurement and for the results to qualify for SAR test exclusion.

**9.4 SAR Measurement for LTE**

SAR tests for LTE are performed with a base station simulator, Rohde & Schwarz CMW500. Closed loop power control was used so the UE transmits with maximum output power during SAR testing. All powers were measured with the CMW 500.

It is performed for conducted power and SAR based on the KDB941225 D05.

SAR is evaluated separately according to the following procedures for the different test positions in each exposure condition – head, body, body-worn accessories and other use conditions. The procedures in the following subsections are applied separately to test each LTE frequency band.

1) QPSK with 1 RB allocation

Start with the largest channel bandwidth and measure SAR for QPSK with 1 RB allocation, using the RB offset and required test channel combination with the highest maximum output power among RB offsets at the upper edge, middle and lower edge of each required test channel. When the reported SAR is  $\leq 0.8$  W/kg, testing of the remaining RB offset configurations and required test channels is not required for 1 RB allocation; otherwise, SAR is required for the remaining required test channels and only for the RB offset configuration with the highest output power for that channel. When the reported SAR of a required test channel is  $> 1.45$  W/kg, SAR is required for all three RB offset configurations for that required test channel.

2) QPSK with 50% RB allocation

The procedures required for 1 RB allocation in 1) are applied to measure the SAR for QPSK with 50% RB allocation.

3) QPSK with 100% RB allocation

For QPSK with 100% RB allocation, SAR is not required when the highest maximum output power for 100 % RB allocation is less than the highest maximum output power in 50% and 1 RB allocations and the highest reported SAR for 1 RB and 50% RB allocation in 1) and 2) are  $\leq 0.8$  W/kg. Otherwise, SAR is measured for the highest output power channel; and if the reported SAR is  $> 1.45$  W/kg, the remaining required test channels must also be tested.

## 9.5 Bluetooth & Wi-Fi Measurement Procedures for SAR

Normal network operating configurations are not suitable for measuring the SAR of 802.11 transmitters in general. Unpredictable fluctuations in network traffic and antenna diversity conditions can introduce undesirable variations in SAR results. The SAR for these devices should be measured using chipset based test mode software to ensure that the results are consistent and reliable.

Chipset based test mode software is hardware dependent and generally varies among manufacturers. The device operating parameters established in a test mode for SAR measurements must be identical to those programmed in production units, including output power levels, amplifier gain settings and other RF performance tuning parameters. The test frequencies should correspond to actual channel frequencies defined for domestic use. SAR for devices with switched diversity should be measured with only one antenna transmitting at a time during each SAR measurement, according to a fixed modulation and data rate. The same data pattern should be used for all measurements.

## 9.6 Power Drift

To control the output power stability during the SAR test, DASY4 system calculates the power drift by measuring the E-field at the same location at the beginning and at the end of the measurement for each test position. These drift values can be found in Table 14.2 to Table 14.37 labeled as: (Power Drift [dB]). This ensures that the power drift during one measurement is within 5%.

## 10 Area Scan Based 1-g SAR

### 10.1 Requirement of KDB

According to the KDB447498 D01 v05, when the implementation is based the specific polynomial fit algorithm as presented at the 29th Bioelectromagnetics Society meeting (2007) and the estimated 1-g SAR is  $\leq 1.2$  W/kg, a zoom scan measurement is not required provided it is also not needed for any other purpose; for example, if the peak SAR location required for simultaneous transmission SAR test exclusion can be determined accurately by the SAR system or manually to discriminate between distinctive peaks and scattered noisy SAR distributions from area scans.

There must not be any warning or alert messages due to various measurement concerns identified by the SAR system; for example, noise in measurements, peaks too close to scan boundary, peaks are too sharp, spatial resolution and uncertainty issues etc. The SAR system verification must also demonstrate that the area scan estimated 1-g SAR is within 3% of the zoom scan 1-g SAR (See Annex B). When all the SAR results for each exposure condition in a frequency band and wireless mode are based on estimated 1-g SAR, the 1-g SAR for the highest SAR configuration must be determined by a zoom scan.

### 10.2 Fast SAR Algorithms

The approach is based on the area scan measurement applying a frequency dependent attenuation parameter. This attenuation parameter was empirically determined by analyzing a large number of phones. The MOTOROLA FAST SAR was developed and validated by the MOTOROLA Research Group in Ft. Lauderdale.

In the initial study, an approximation algorithm based on Linear fit was developed. The accuracy of the algorithm has been demonstrated across a broad frequency range (136-2450 MHz) and for both 1- and 10-g averaged SAR using a sample of 264 SAR measurements from 55 wireless handsets. For the sample size studied, the root-mean-squared errors of the algorithm are 1.2% and 5.8% for 1- and 10-g averaged SAR, respectively. The paper describing the algorithm in detail is expected to be published in August 2004 within the Special Issue of Transactions on MTT.

In the second step, the same research group optimized the fitting algorithm to an Polynomial fit whereby the frequency validity was extended to cover the range 30-6000MHz. Details of this study can be found in the BEMS 2007 Proceedings.

Both algorithms are implemented in DASY software.

## 11 Conducted Output Power

### 11.1 Manufacturing tolerance

**Table 11.1: GSM Speech**

GSM 850			
Channel	Channel 251	Channel 190	Channel 128
Target (dBm)	32.8	32.8	32.8
Tune-up (dBm)	33.3	33.3	33.3
GSM 1900			
Channel	Channel 810	Channel 661	Channel 512
Target (dBm)	29.8	29.8	29.8
Tune-up (dBm)	30.3	30.3	30.3

**Table 11.2: GPRS and EGPRS**

GSM 850 GPRS (GMSK)				
Channel		251	190	128
1 Txslot	Target (dBm)	32.8	32.8	32.8
	Tune-up (dBm)	33.3	33.3	33.3
2 Txslots	Target (dBm)	30.8	30.8	30.8
	Tune-up (dBm)	31.3	31.3	31.3
3 Txslots	Target (dBm)	28.8	28.8	28.8
	Tune-up (dBm)	29.3	29.3	29.3
4 Txslots	Target (dBm)	27.3	27.3	27.3
	Tune-up (dBm)	27.8	27.8	27.8
GSM 850 EGPRS (GMSK)				
Channel		251	190	128
1 Txslot	Target (dBm)	32.8	32.8	32.8
	Tune-up (dBm)	33.3	33.3	33.3
2 Txslots	Target (dBm)	30.8	30.8	30.8
	Tune-up (dBm)	31.3	31.3	31.3
3 Txslots	Target (dBm)	28.8	28.8	28.8
	Tune-up (dBm)	29.3	29.3	29.3
4 Txslots	Target (dBm)	27.3	27.3	27.3
	Tune-up (dBm)	27.8	27.8	27.8
GSM 1900 GPRS (GMSK)				
Channel		810	661	512
1 Txslot	Target (dBm)	29.8	29.8	29.8
	Tune-up (dBm)	30.3	30.3	30.3
2 Txslots	Target (dBm)	27.8	27.8	27.8
	Tune-up (dBm)	28.3	28.3	28.3
3 Txslots	Target (dBm)	25.8	25.8	25.8
	Tune-up (dBm)	26.3	26.3	26.3
4 Txslots	Target (dBm)	24.3	24.3	24.3
	Tune-up (dBm)	24.8	24.8	24.8

GSM 1900 EGPRS (GMSK)				
Channel		810	661	512
1 Txslot	Target (dBm)	29.8	29.8	29.8
	Tune-up (dBm)	30.3	30.3	30.3
2 Txslots	Target (dBm)	27.8	27.8	27.8
	Tune-up (dBm)	28.3	28.3	28.3
3 Txslots	Target (dBm)	25.8	25.8	25.8
	Tune-up (dBm)	26.3	26.3	26.3
4 Txslots	Target (dBm)	24.3	24.3	24.3
	Tune-up (dBm)	24.8	24.8	24.8

**Table 11.3: WCDMA**

WCDMA 850 CS				
Channel	Channel 4233	Channel 4182	Channel 4132	
Target (dBm)	23.5	23.5	23.5	
Tune-up (dBm)	24	24	24	
HSUPA (sub-test 1/2)				
Channel	Channel 4233	Channel 4182	Channel 4132	
Target (dBm)	20.5	20.5	20.5	
Tune-up (dBm)	21	21	21	
HSUPA (sub-test 3)				
Channel	Channel 4233	Channel 4182	Channel 4132	
Target (dBm)	21.5	21.5	21.5	
Tune-up (dBm)	22	22	22	
HSUPA (sub-test 4)				
Channel	Channel 4233	Channel 4182	Channel 4132	
Target (dBm)	20	20	20	
Tune-up (dBm)	20.5	20.5	20.5	
HSUPA (sub-test 5)				
Channel	Channel 4233	Channel 4182	Channel 4132	
Target (dBm)	22.5	22.5	22.5	
Tune-up (dBm)	23	23	23	
HSPA+ (sub-test 1)				
Channel	Channel 4233	Channel 4182	Channel 4132	
Target (dBm)	21.5	21.5	21.5	
Tune-up (dBm)	22	22	22	
DC-HSDPA (sub-test 1/2)				
Channel	Channel 4233	Channel 4182	Channel 4132	
Target (dBm)	22.5	22.5	22.5	
Tune-up (dBm)	23	23	23	
DC-HSDPA (sub-test 3/4)				
Channel	Channel 4233	Channel 4182	Channel 4132	
Target (dBm)	22	22	22	
Tune-up (dBm)	22.5	22.5	22.5	

WCDMA 1900 CS			
Channel	Channel 9538	Channel 9400	Channel 9262
Target (dBm)	23.5	23.5	23.5
Tune-up (dBm)	24	24	24
HSUPA (sub-test 1/2)			
Channel	Channel 9538	Channel 9400	Channel 9262
Target (dBm)	20.5	20.5	20.5
Tune-up (dBm)	21	21	21
HSUPA (sub-test 3)			
Channel	Channel 9538	Channel 9400	Channel 9262
Target (dBm)	21.5	21.5	21.5
Tune-up (dBm)	22	22	22
HSUPA (sub-test 4)			
Channel	Channel 9538	Channel 9400	Channel 9262
Target (dBm)	20	20	20
Tune-up (dBm)	20.5	20.5	20.5
HSUPA (sub-test 5)			
Channel	Channel 9538	Channel 9400	Channel 9262
Target (dBm)	22.5	22.5	22.5
Tune-up (dBm)	23	23	23
HSPA+ (sub-test 1)			
Channel	Channel 9538	Channel 9400	Channel 9262
Target (dBm)	21.5	21.5	21.5
Tune-up (dBm)	22	22	22
DC-HSDPA (sub-test 1/2)			
Channel	Channel 9538	Channel 9400	Channel 9262
Target (dBm)	22.5	22.5	22.5
Tune-up (dBm)	23	23	23
DC-HSDPA (sub-test 3/4)			
Channel	Channel 9538	Channel 9400	Channel 9262
Target (dBm)	22	22	22
Tune-up (dBm)	22.5	22.5	22.5

**Table 11.4: LTE**

Mode	Target (dBm)	Tune-up (dBm)
LTE Band 2	23	23.5
LTE Band 4	23	23.5
LTE Band 7	22.5	23



**LTE MPR will follow up 3GPP setting as below:**

Modulation	Channel bandwidth / Transmission bandwidth (NRB)						MPR (dB)
	1.4MHz	3.0MHz	5MHz	10MHz	15MHz	20MHz	
QPSK	> 5	> 4	> 8	> 12	> 16	> 18	1
16 QAM	≤ 5	≤ 4	≤ 8	≤ 12	≤ 16	≤ 18	1
16 QAM	> 5	> 4	> 8	> 12	> 16	> 18	2

**Table 11.5: Bluetooth**

Mode	Target (dBm)	Tune-up (dBm)
GFSK	7	8

**Table 11.6: WiFi**

Mode	Target (dBm)	Tune-up (dBm)
802.11b (2.4G)	18	18.5
802.11g (2.4G) 36Mbps	14.5	15
802.11g (2.4G) others	16	16.5
802.11n (2.4G)	13.5	14
802.11a (5G) 6/12/18/48/54Mbps	12.5	13
802.11a (5G) 9/24/36Mbps	12.5	13
802.11n - HT20 (5G)	11.5	12
802.11n – HT40 (5G) channel 38	10.8	11.3
802.11n – HT40 (5G) others	11.5	12

## 11.2 GSM Measurement result

During the process of testing, the EUT was controlled via Agilent Digital Radio Communication tester (E5515C) to ensure the maximum power transmission and proper modulation. This result contains conducted output power for the EUT. In all cases, the measured peak output power should be greater and within 5% than EMI measurement.

**Table 11.7: The conducted power measurement results for GSM850/1900**

GSM 850MHz	Conducted Power (dBm)		
	Channel 251(848.8MHz)	Channel 190(836.6MHz)	Channel 128(824.2MHz)
	32.70	32.73	32.72
GSM 1900MHz	Conducted Power (dBm)		
	Channel 810(1909.8MHz)	Channel 661(1880MHz)	Channel 512(1850.2MHz)
	30.16	30.07	29.99

**Table 11.8: The conducted power measurement results for GPRS and EGPRS**

GSM 850 GPRS (GMSK)	Measured Power (dBm)			calculation	Averaged Power (dBm)		
	251	190	128		251	190	128
1 Txslot	32.73	32.76	32.74	-9.03dB	23.70	23.73	23.71
<b>2 Txslots</b>	31.10	31.09	31.12	-6.02dB	<b>25.08</b>	<b>25.07</b>	<b>25.10</b>
3Txslots	29.09	29.09	29.12	-4.26dB	24.83	24.83	24.86
4 Txslots	27.61	27.63	27.63	-3.01dB	24.60	24.62	24.62
GSM 850 EGPRS (GMSK)	Measured Power (dBm)			calculation	Averaged Power (dBm)		
	251	190	128		251	190	128
1 Txslot	32.69	32.72	32.70	-9.03dB	23.66	23.69	23.67
<b>2 Txslots</b>	31.05	31.09	31.07	-6.02dB	<b>25.03</b>	<b>25.07</b>	<b>25.05</b>
3Txslots	29.06	29.10	29.09	-4.26dB	24.80	24.84	24.83
4 Txslots	27.58	27.63	27.62	-3.01dB	24.57	24.62	24.61
PCS1900 GPRS (GMSK)	Measured Power (dBm)			calculation	Averaged Power (dBm)		
	810	661	512		810	661	512
1 Txslot	30.26	30.14	30.05	-9.03dB	21.23	21.11	21.02
<b>2 Txslots</b>	28.29	28.17	27.96	-6.02dB	<b>22.27</b>	<b>22.15</b>	<b>21.94</b>
3Txslots	26.29	26.00	25.69	-4.26dB	22.03	21.74	21.43
4 Txslots	24.78	24.50	24.17	-3.01dB	21.77	21.49	21.16
PCS1900 EGPRS (GMSK)	Measured Power (dBm)			calculation	Averaged Power (dBm)		
	810	661	512		810	661	512
1 Txslot	30.25	30.14	30.06	-9.03dB	21.22	21.11	21.03
<b>2 Txslots</b>	28.28	28.18	27.96	-6.02dB	<b>22.26</b>	<b>22.16</b>	<b>21.94</b>
3Txslots	26.29	26.00	25.68	-4.26dB	22.03	21.74	21.42
4 Txslots	24.78	24.50	24.16	-3.01dB	21.77	21.49	21.15

NOTES:

1) Division Factors

To average the power, the division factor is as follows:

1TX-slot = 1 transmit time slot out of 8 time slots=> conducted power divided by (8/1) => -9.03dB

2TX-slots = 2 transmit time slots out of 8 time slots=> conducted power divided by (8/2) => -6.02dB

3TX-slots = 3 transmit time slots out of 8 time slots=> conducted power divided by (8/3) => -4.26dB

4TX-slots = 4 transmit time slots out of 8 time slots=> conducted power divided by (8/4) => -3.01dB

According to the conducted power as above, the body measurements are performed with 2Txslots for GPRS and EGPRS.

Note: According to the KDB941225 D03, “when SAR tests for EDGE or EGPRS mode is necessary, GMSK modulation should be used”.

### 11.3 WCDMA Measurement result

Table 11.9: The conducted Power for WCDMA

Item	band	FDDV result		
	ARFCN	4233 (846.6MHz)	4182 (836.4MHz)	4132 (826.4MHz)
WCDMA	\	23.50	23.47	23.50
HSUPA	1	20.07	20.42	20.40
	2	20.05	20.40	20.30
	3	21.05	21.40	21.37
	4	19.53	19.89	19.87
	5	22.04	22.39	22.36
HSPA+(16QAM)	1	21.41	21.21	21.20
DC-HSDPA	1	22.92	22.75	22.72
	2	22.91	22.78	22.74
	3	22.40	22.21	22.20
	4	22.39	22.23	22.22
Item	band	FDDII result		
	ARFCN	9538 (1907.6MHz)	9400 (1880MHz)	9262 (1852.4MHz)
WCDMA	\	23.27	23.20	23.11
HSUPA	1	19.73	20.04	20.05
	2	19.64	19.93	20.05
	3	20.64	20.93	21.05
	4	19.23	19.52	19.55
	5	21.62	21.91	22.02
HSPA+(16QAM)	1	21.12	21.06	21.03
DC-HSDPA	1	22.51	22.53	22.49
	2	22.52	22.51	22.48
	3	22.05	22.03	22.01
	4	22.07	22.08	22.03

Note: R6/7/8 body SAR for WCDMA850/1900 are not required, because maximum average output power of each RF channel with R6/7/8 active is not 1/4 dB higher than that measured without R6/7/8 and the maximum SAR for WCDMA850/1900 are not above 75% of the SAR limit.

### 11.4 LTE Measurement result

**Table 11.10: The conducted Power for LTE**

Band 2								
Bandwidth (MHz)	RB allocation	Frequency (MHz)	Max. Target Power (dBm)	QPSK		16QAM		
	RB offset (Start RB)			Actual output power (dBm)	MPR	Actual output power (dBm)	MPR	
1.4 MHz	1RB High (5)	1909.3	23.5	23.37	0	22.39	1	
		1880	23.5	23.16	0	22.05	1	
		1850.7	23.5	23.24	0	22.41	1	
	1RB Middle (3)	1909.3	23.5	23.42	0	22.50	1	
		1880	23.5	23.24	0	22.19	1	
		1850.7	23.5	23.32	0	22.49	1	
	1RB Low (0)	1909.3	23.5	23.37	0	22.40	1	
		1880	23.5	23.18	0	22.08	1	
		1850.7	23.5	23.26	0	22.40	1	
	3RB High (3)	1909.3	23.5	23.39	0	22.45	1	
		1880	23.5	23.21	0	22.28	1	
		1850.7	23.5	23.34	0	22.30	1	
	3RB Middle (1)	1909.3	23.5	23.38	0	22.42	1	
		1880	23.5	23.23	0	22.27	1	
		1850.7	23.5	23.30	0	22.28	1	
	3RB Low (0)	1909.3	23.5	23.40	0	22.44	1	
		1880	23.5	23.22	0	22.33	1	
		1850.7	23.5	23.33	0	22.30	1	
	6RB (0)	1909.3	23.5	22.41	1	21.31	2	
		1880	23.5	22.24	1	21.26	2	
		1850.7	23.5	22.32	1	21.42	2	
	3 MHz	1RB High (14)	1908.5	23.5	23.22	0	22.49	1
			1880	23.5	23.15	0	22.47	1
			1851.5	23.5	23.07	0	22.30	1
1RB Middle (7)		1908.5	23.5	23.35	0	22.40	1	
		1880	23.5	23.19	0	22.42	1	
		1851.5	23.5	23.14	0	22.46	1	
1RB Low (0)		1908.5	23.5	23.22	0	22.49	1	
		1880	23.5	23.16	0	22.45	1	
		1851.5	23.5	23.28	0	22.48	1	
8RB High (7)		1908.5	23.5	22.19	1	21.25	2	
		1880	23.5	22.18	1	21.16	2	
		1851.5	23.5	22.05	1	21.00	2	
8RB Middle (4)		1908.5	23.5	22.15	1	21.16	2	
		1880	23.5	22.08	1	21.14	2	
		1851.5	23.5	22.07	1	21.12	2	

	8RB Low (0)	1908.5	23.5	22.20	1	21.15	2	
		1880	23.5	22.17	1	21.16	2	
		1851.5	23.5	22.13	1	21.07	2	
	15RB (0)	1908.5	23.5	22.19	1	21.20	2	
		1880	23.5	22.13	1	21.14	2	
		1851.5	23.5	22.10	1	21.13	2	
5 MHz	1RB High (24)	1907.5	23.5	23.23	0	22.50	1	
		1880	23.5	23.16	0	22.47	1	
		1852.5	23.5	23.09	0	22.32	1	
	1RB Middle (12)	1907.5	23.5	23.35	0	22.43	1	
		1880	23.5	23.21	0	22.45	1	
		1852.5	23.5	23.16	0	22.48	1	
	1RB Low (0)	1907.5	23.5	23.23	0	22.46	1	
		1880	23.5	23.18	0	22.47	1	
		1852.5	23.5	23.29	0	22.50	1	
	12RB High (13)	1907.5	23.5	22.21	1	21.26	2	
		1880	23.5	22.20	1	21.18	2	
		1852.5	23.5	22.07	1	21.02	2	
	12RB Middle (6)	1907.5	23.5	22.17	1	21.17	2	
		1880	23.5	22.10	1	21.14	2	
		1852.5	23.5	22.09	1	21.14	2	
	12RB Low (0)	1907.5	23.5	22.21	1	21.16	2	
		1880	23.5	22.18	1	21.18	2	
		1852.5	23.5	22.15	1	21.10	2	
	25RB (0)	1907.5	23.5	22.21	1	21.21	2	
		1880	23.5	22.15	1	21.16	2	
		1852.5	23.5	22.11	1	21.15	2	
	10 MHz	1RB High (49)	1905	23.5	23.24	0	22.45	1
			1880	23.5	23.16	0	22.43	1
			1855	23.5	23.08	0	22.34	1
1RB Middle (24)		1905	23.5	23.37	0	22.45	1	
		1880	23.5	23.22	0	22.42	1	
		1855	23.5	23.16	0	22.44	1	
1RB Low (0)		1905	23.5	23.22	0	22.48	1	
		1880	23.5	23.20	0	22.47	1	
		1855	23.5	23.31	0	22.50	1	
25RB High (25)		1905	23.5	22.23	1	21.26	2	
		1880	23.5	22.20	1	21.20	2	
		1855	23.5	22.11	1	21.05	2	
25RB Middle (12)		1905	23.5	22.15	1	21.18	2	
		1880	23.5	22.13	1	21.15	2	
		1855	23.5	22.09	1	21.14	2	

	25RB Low (0)	1905	23.5	22.22	1	21.16	2	
		1880	23.5	22.20	1	21.19	2	
		1855	23.5	22.17	1	21.13	2	
	50RB (0)	1905	23.5	22.23	1	21.21	2	
		1880	23.5	22.18	1	21.17	2	
		1855	23.5	22.12	1	21.17	2	
15 MHz	1RB High (74)	1902.5	23.5	23.28	0	22.50	1	
		1880	23.5	23.14	0	22.44	1	
		1857.5	23.5	23.13	0	22.33	1	
	1RB Middle (37)	1902.5	23.5	23.33	0	22.41	1	
		1880	23.5	23.24	0	22.44	1	
		1857.5	23.5	23.20	0	22.47	1	
	1RB Low (0)	1902.5	23.5	23.22	0	22.48	1	
		1880	23.5	23.17	0	22.44	1	
		1857.5	23.5	23.31	0	22.45	1	
	36RB High (38)	1902.5	23.5	22.20	1	21.26	2	
		1880	23.5	22.23	1	21.16	2	
		1857.5	23.5	22.09	1	21.02	2	
	36RB Middle (19)	1902.5	23.5	22.18	1	21.18	2	
		1880	23.5	22.11	1	21.15	2	
		1857.5	23.5	22.13	1	21.14	2	
	36RB Low (0)	1902.5	23.5	22.21	1	21.19	2	
		1880	23.5	22.17	1	21.20	2	
		1857.5	23.5	22.18	1	21.13	2	
	75RB (0)	1902.5	23.5	22.25	1	21.20	2	
		1880	23.5	22.17	1	21.16	2	
		1857.5	23.5	22.15	1	21.16	2	
	20 MHz	1RB High (99)	1900	23.5	23.25	0	22.49	1
			1880	23.5	23.19	0	22.46	1
			1860	23.5	23.11	0	22.33	1
		1RB Middle (50)	1900	23.5	23.38	0	22.44	1
			1880	23.5	23.23	0	22.45	1
			1860	23.5	23.18	0	22.49	1
1RB Low (0)		1900	23.5	23.26	0	22.47	1	
		1880	23.5	23.20	0	22.49	1	
		1860	23.5	23.32	0	22.45	1	
50RB High (50)		1900	23.5	22.23	1	21.28	2	
		1880	23.5	22.22	1	21.19	2	
		1860	23.5	22.08	1	21.04	2	
50RB Middle (25)		1900	23.5	22.21	1	21.20	2	
		1880	23.5	22.13	1	21.16	2	
		1860	23.5	22.11	1	21.14	2	

	50RB Low (0)	1900	23.5	22.24	1	21.18	2	
		1880	23.5	22.21	1	21.18	2	
		1860	23.5	22.16	1	21.11	2	
	100RB (0)	1900	23.5	22.23	1	21.23	2	
		1880	23.5	22.16	1	21.18	2	
		1860	23.5	22.14	1	21.17	2	
Band 4								
Bandwidth (MHz)	RB allocation	Frequency (MHz)	Max. Target Power (dBm)	QPSK		16QAM		
	RB offset (Start RB)			Actual output power (dBm)	MPR	Actual output power (dBm)	MPR	
1.4 MHz	1RB High (5)	1754.3	23.5	23.17	0	22.34	1	
		1732.5	23.5	23.25	0	22.45	1	
		1710.7	23.5	23.21	0	22.46	1	
	1RB Middle (3)	1754.3	23.5	23.24	0	22.32	1	
		1732.5	23.5	23.37	0	22.41	1	
		1710.7	23.5	23.40	0	22.48	1	
	1RB Low (0)	1754.3	23.5	23.41	0	22.44	1	
		1732.5	23.5	23.25	0	22.43	1	
		1710.7	23.5	23.41	0	22.39	1	
	3RB High (3)	1754.3	23.5	23.26	0	22.26	1	
		1732.5	23.5	23.34	0	22.36	1	
		1710.7	23.5	23.30	0	22.34	1	
	3RB Middle (1)	1754.3	23.5	23.27	0	22.29	1	
		1732.5	23.5	23.33	0	22.35	1	
		1710.7	23.5	23.28	0	22.34	1	
	3RB Low (0)	1754.3	23.5	23.30	0	22.35	1	
		1732.5	23.5	23.36	0	22.46	1	
		1710.7	23.5	23.29	0	22.37	1	
	6RB (0)	1754.3	23.5	22.31	1	21.31	2	
		1732.5	23.5	22.32	1	21.28	2	
		1710.7	23.5	22.35	1	21.31	2	
	3 MHz	1RB High (14)	1753.5	23.5	23.10	0	23.10	1
			1732.5	23.5	23.22	0	23.22	1
			1711.5	23.5	23.17	0	23.17	1
		1RB Middle (7)	1753.5	23.5	23.17	0	23.17	1
			1732.5	23.5	23.30	0	23.30	1
			1711.5	23.5	23.37	0	23.37	1
1RB Low (0)		1753.5	23.5	23.38	0	23.38	1	
		1732.5	23.5	23.24	0	23.24	1	
		1711.5	23.5	23.36	0	23.36	1	
8RB High (7)		1753.5	23.5	22.25	1	22.25	2	
		1732.5	23.5	22.34	1	22.34	2	
		1711.5	23.5	22.34	1	22.34	2	

	8RB Middle (4)	1753.5	23.5	22.28	1	22.28	2	
		1732.5	23.5	22.33	1	22.33	2	
		1711.5	23.5	22.31	1	22.31	2	
	8RB Low (0)	1753.5	23.5	22.32	1	22.32	2	
		1732.5	23.5	22.30	1	22.30	2	
		1711.5	23.5	22.35	1	22.35	2	
	15RB (0)	1753.5	23.5	22.30	1	22.30	2	
		1732.5	23.5	22.29	1	22.29	2	
		1711.5	23.5	22.35	1	22.35	2	
5 MHz	1RB High (24)	1752.5	23.5	23.15	0	22.33	1	
		1732.5	23.5	23.22	0	22.42	1	
		1712.5	23.5	23.20	0	22.41	1	
	1RB Middle (12)	1752.5	23.5	23.21	0	22.30	1	
		1732.5	23.5	23.35	0	22.36	1	
		1712.5	23.5	23.38	0	22.45	1	
	1RB Low (0)	1752.5	23.5	23.36	0	22.43	1	
		1732.5	23.5	23.23	0	22.40	1	
		1712.5	23.5	23.37	0	22.38	1	
	12RB High (13)	1752.5	23.5	22.24	1	21.23	2	
		1732.5	23.5	22.33	1	21.31	2	
		1712.5	23.5	22.30	1	21.33	2	
	12RB Middle (6)	1752.5	23.5	22.27	1	21.28	2	
		1732.5	23.5	22.31	1	21.35	2	
		1712.5	23.5	22.30	1	21.33	2	
	12RB Low (0)	1752.5	23.5	22.33	1	21.30	2	
		1732.5	23.5	22.34	1	21.42	2	
		1712.5	23.5	22.35	1	21.34	2	
	25RB (0)	1752.5	23.5	22.30	1	21.29	2	
		1732.5	23.5	22.28	1	21.32	2	
		1712.5	23.5	22.32	1	21.32	2	
	10 MHz	1RB High (49)	1750	23.5	23.15	0	22.29	1
			1732.5	23.5	23.21	0	22.41	1
			1715	23.5	23.20	0	22.40	1
1RB Middle (24)		1750	23.5	23.21	0	22.26	1	
		1732.5	23.5	23.30	0	22.36	1	
		1715	23.5	23.36	0	22.49	1	
1RB Low (0)		1750	23.5	23.34	0	22.46	1	
		1732.5	23.5	23.18	0	22.38	1	
		1715	23.5	23.35	0	22.39	1	
25RB High (25)		1750	23.5	22.20	1	21.23	2	
		1732.5	23.5	22.28	1	21.30	2	
		1715	23.5	22.29	1	21.33	2	



	25RB Middle (12)	1750	23.5	22.25	1	21.25	2	
		1732.5	23.5	22.33	1	21.34	2	
		1715	23.5	22.32	1	21.30	2	
	25RB Low (0)	1750	23.5	22.31	1	21.32	2	
		1732.5	23.5	22.33	1	21.42	2	
		1715	23.5	22.30	1	21.34	2	
	50RB (0)	1750	23.5	22.25	1	21.27	2	
		1732.5	23.5	22.24	1	21.32	2	
		1715	23.5	22.31	1	21.31	2	
15 MHz	1RB High (74)	1747.5	23.5	23.05	0	22.26	1	
		1732.5	23.5	23.11	0	22.38	1	
		1717.5	23.5	23.13	0	22.37	1	
	1RB Middle (37)	1747.5	23.5	23.12	0	22.22	1	
		1732.5	23.5	23.27	0	22.32	1	
		1717.5	23.5	23.30	0	22.46	1	
	1RB Low (0)	1747.5	23.5	23.29	0	22.49	1	
		1732.5	23.5	23.10	0	22.32	1	
		1717.5	23.5	23.31	0	22.31	1	
	36RB High (38)	1747.5	23.5	22.16	1	21.15	2	
		1732.5	23.5	22.25	1	21.30	2	
		1717.5	23.5	22.27	1	21.27	2	
	36RB Middle (19)	1747.5	23.5	22.20	1	21.22	2	
		1732.5	23.5	22.23	1	21.30	2	
		1717.5	23.5	22.24	1	21.27	2	
	36RB Low (0)	1747.5	23.5	22.29	1	21.28	2	
		1732.5	23.5	22.30	1	21.38	2	
		1717.5	23.5	22.28	1	21.30	2	
	75RB (0)	1747.5	23.5	22.23	1	21.23	2	
		1732.5	23.5	22.21	1	21.27	2	
		1717.5	23.5	22.28	1	21.27	2	
	20 MHz	1RB High (99)	1745	23.5	23.13	0	22.31	1
			1732.5	23.5	23.20	0	22.44	1
			1720	23.5	23.18	0	22.43	1
		1RB Middle (50)	1745	23.5	23.19	0	22.29	1
			1732.5	23.5	23.33	0	22.38	1
			1720	23.5	23.39	0	22.50	1
1RB Low (0)		1745	23.5	23.37	0	22.45	1	
		1732.5	23.5	23.21	0	22.41	1	
		1720	23.5	23.38	0	22.37	1	
50RB High (50)		1745	23.5	22.23	1	21.21	2	
		1732.5	23.5	22.31	1	21.33	2	
		1720	23.5	22.32	1	21.32	2	

	50RB Middle (25)	1745	23.5	22.26	1	21.26	2
		1732.5	23.5	22.30	1	21.36	2
		1720	23.5	22.30	1	21.31	2
	50RB Low (0)	1745	23.5	22.34	1	21.32	2
		1732.5	23.5	22.35	1	21.43	2
		1720	23.5	22.33	1	21.35	2
	100RB (0)	1745	23.5	22.28	1	21.28	2
		1732.5	23.5	22.27	1	21.31	2
		1720	23.5	22.34	1	21.33	2
Band 7							
Bandwidth (MHz)	RB allocation	Frequency (MHz)	Max. Target Power (dBm)	QPSK		16QAM	
	RB offset (Start RB)			Actual output power (dBm)	MPR	Actual output power (dBm)	MPR
5 MHz	1RB High (24)	2567.5	23	22.81	0	22.81	1
		2535	23	22.66	0	22.66	1
		2502.5	23	22.80	0	22.80	1
	1RB Middle (12)	2567.5	23	22.73	0	22.73	1
		2535	23	22.62	0	22.62	1
		2502.5	23	22.65	0	22.65	1
	1RB Low (0)	2567.5	23	22.69	0	22.69	1
		2535	23	22.63	0	22.63	1
		2502.5	23	22.75	0	22.75	1
	12RB High (13)	2567.5	23	21.94	1	21.94	2
		2535	23	21.54	1	21.54	2
		2502.5	23	21.64	1	21.64	2
	12RB Middle (6)	2567.5	23	21.86	1	21.86	2
		2535	23	21.56	1	21.56	2
		2502.5	23	21.70	1	21.70	2
	12RB Low (0)	2567.5	23	21.81	1	21.81	2
		2535	23	21.58	1	21.58	2
		2502.5	23	21.76	1	21.76	2
	25RB (0)	2567.5	23	21.84	1	21.84	2
		2535	23	21.58	1	21.58	2
		2502.5	23	21.73	1	21.73	2
10 MHz	1RB High (49)	2565	23	22.85	0	22.85	1
		2535	23	22.68	0	22.68	1
		2505	23	22.82	0	22.82	1
	1RB Middle (24)	2565	23	22.76	0	22.76	1
		2535	23	22.64	0	22.64	1
		2505	23	22.70	0	22.70	1
	1RB Low (0)	2565	23	22.71	0	22.71	1
		2535	23	22.67	0	22.67	1
		2505	23	22.79	0	22.79	1

	25RB High (25)	2565	23	21.97	1	21.97	2	
		2535	23	21.60	1	21.60	2	
		2505	23	21.63	1	21.63	2	
	25RB Middle (12)	2565	23	21.87	1	21.87	2	
		2535	23	21.56	1	21.56	2	
		2505	23	21.73	1	21.73	2	
	25RB Low (0)	2565	23	21.85	1	21.85	2	
		2535	23	21.60	1	21.60	2	
		2505	23	21.81	1	21.81	2	
	50RB (0)	2565	23	21.88	1	21.88	2	
		2535	23	21.61	1	21.61	2	
		2505	23	21.75	1	21.75	2	
15 MHz	1RB High (74)	2562.5	23	22.87	0	21.96	1	
		2535	23	22.73	0	21.88	1	
		2507.5	23	22.84	0	21.88	1	
	1RB Middle (37)	2562.5	23	22.78	0	21.99	1	
		2535	23	22.67	0	21.69	1	
		2507.5	23	22.71	0	21.71	1	
	1RB Low (0)	2562.5	23	22.70	0	21.96	1	
		2535	23	22.68	0	21.98	1	
		2507.5	23	22.80	0	21.97	1	
	36RB High (38)	2562.5	23	21.98	1	20.94	2	
		2535	23	21.62	1	20.63	2	
		2507.5	23	21.68	1	20.75	2	
	36RB Middle (19)	2562.5	23	21.89	1	20.87	2	
		2535	23	21.58	1	20.64	2	
		2507.5	23	21.76	1	20.77	2	
	36RB Low (0)	2562.5	23	21.87	1	20.82	2	
		2535	23	21.61	1	20.65	2	
		2507.5	23	21.80	1	20.85	2	
	75RB (0)	2562.5	23	21.88	1	20.88	2	
		2535	23	21.61	1	20.65	2	
		2507.5	23	21.77	1	20.77	2	
	20 MHz	1RB High (99)	2560	23	22.88	0	21.94	1
			2535	23	22.71	0	21.89	1
			2510	23	22.85	0	21.88	1
1RB Middle (50)		2560	23	22.78	0	21.98	1	
		2535	23	22.65	0	21.67	1	
		2510	23	22.70	0	21.70	1	
1RB Low (0)		2560	23	22.74	0	21.97	1	
		2535	23	22.69	0	21.96	1	
		2510	23	22.81	0	21.97	1	



	50RB High (50)	2560	23	22.00	1	20.96	2
		2535	23	21.60	1	20.61	2
		2510	23	21.69	1	20.73	2
	50RB Middle (25)	2560	23	21.90	1	20.89	2
		2535	23	21.59	1	20.62	2
		2510	23	21.75	1	20.77	2
	50RB Low (0)	2560	23	21.88	1	20.85	2
		2535	23	21.63	1	20.64	2
		2510	23	21.82	1	20.86	2
	100RB (0)	2560	23	21.90	1	20.88	2
		2535	23	21.60	1	20.62	2
		2510	23	21.76	1	20.78	2

### 11.6 Wi-Fi and BT Measurement result

The output power of BT antenna is as following:

Mode	Conducted Power (dBm)		
	Channel 0 (2402MHz)	Channel 39 (2441MHz)	Channel 78 (2480MHz)
GFSK	6.36	7.74	6.24

The average conducted power for Wi-Fi is as following:

802.11b (dBm)

Channel\data rate	1Mbps	2Mbps	5.5Mbps	11Mbps
1	18.34	17.04	17.09	17.04
6	17.55	/	/	/
11	17.21	/	/	/

802.11g (dBm)

Channel\data rate	6Mbps	9Mbps	12Mbps	18Mbps	24Mbps	36Mbps	48Mbps	54Mbps
1	14.89	/	/	/	/	/	/	/
6	16.25	14.65	16.16	16.06	14.60	14.18	16.02	15.95
11	15.54	/	/	/	/	/	/	/

802.11n (dBm) - HT20 (2.4G)

Channel\data rate	MCS0	MCS1	MCS2	MCS3	MCS4	MCS5	MCS6	MCS7
1	12.22	/	/	/	/	/	12.55	/
6	12.84	12.58	12.32	12.60	12.81	13.31	13.65	13.57
11	12.23	/	/	/	/	/	12.75	/

802.11n (dBm) – HT40 (2.4G)

Channel\data rate	MCS0	MCS1	MCS2	MCS3	MCS4	MCS5	MCS6	MCS7
3	12.28	/	/	/	/	/	/	12.79
6	12.47	12.45	12.44	12.42	12.46	12.80	12.89	12.96
9	12.12	/	/	/	/	/	/	12.60



802.11a (dBm)

Channel/data rate	6Mbps	9Mbps	12Mbps	18Mbps	24Mbps	36Mbps	48Mbps	54Mbps
36(5180 MHz)	11.36	/	/	/	/	/	/	/
40(5200 MHz)	11.79	/	/	/	/	/	/	/
44(5220 MHz)	12.60	10.74	12.11	12.51	10.22	10.63	12.08	12.30
48(5240 MHz)	12.39	/	/	/	/	/	/	/
52(5260 MHz)	12.56	10.82	11.91	12.51	10.81	10.50	12.51	12.12
56(5280 MHz)	11.88	/	/	/	/	/	/	/
60(5300 MHz)	12.37	/	/	/	/	/	/	/
64(5320 MHz)	11.95	/	/	/	/	/	/	/
100(5500 MHz)	12.69	/	/	/	/	/	/	/
104(5520 MHz)	12.86	11.15	12.38	12.69	11.12	11.10	12.85	12.57
108(5540 MHz)	12.27	/	/	/	/	/	/	/
112(5560 MHz)	12.72	/	/	/	/	/	/	/
116(5580 MHz)	12.70	/	/	/	/	/	/	/
120(5600 MHz)	12.26	/	/	/	/	/	/	/
124(5620 MHz)	12.19	/	/	/	/	/	/	/
128(5640 MHz)	12.55	/	/	/	/	/	/	/
132(5660 MHz)	12.33	/	/	/	/	/	/	/
136(5680 MHz)	12.53	/	/	/	/	/	/	/
140(5700 MHz)	12.15	/	/	/	/	/	/	/
149(5745 MHz)	12.18	/	/	/	/	/	/	/
153(5765 MHz)	12.26	/	/	/	/	/	/	/
157(5785 MHz)	12.34	10.88	12.57	12.58	10.39	10.63	12.56	12.07
161(5805 MHz)	11.88	/	/	/	/	/	/	/
165(5825 MHz)	12.16	/	/	/	/	/	/	/

802.11n (dBm) - HT20 (5G)

Channel/data rate	MCS0	MCS1	MCS2	MCS3	MCS4	MCS5	MCS6	MCS7
36(5180 MHz)	10.85	/	/	/	/	/	/	/
40(5200 MHz)	10.98	/	/	/	/	/	/	/
44(5220 MHz)	11.52	/	/	/	/	/	/	/
48(5240 MHz)	11.59	10.55	11.59	10.97	11.17	11.53	11.30	11.49
52(5260 MHz)	11.01	/	/	/	/	/	/	/
56(5280 MHz)	11.41	/	/	/	/	/	/	/
60(5300 MHz)	11.58	11.09	11.15	11.44	11.16	10.98	11.22	10.96
64(5320 MHz)	11.51	/	/	/	/	/	/	/
100(5500 MHz)	11.74	/	/	/	/	/	/	/
104(5520 MHz)	11.68	/	/	/	/	/	/	/
108(5540 MHz)	11.32	/	/	/	/	/	/	/
112(5560 MHz)	11.78	/	/	/	/	/	/	/
116(5580 MHz)	11.27	/	/	/	/	/	/	/



120(5600 MHz)	11.50	/	/	/	/	/	/	/
124(5620 MHz)	11.07	/	/	/	/	/	/	/
128(5640 MHz)	11.31	/	/	/	/	/	/	/
132(5660 MHz)	11.64	/	/	/	/	/	/	/
136(5680 MHz)	11.36	/	/	/	/	/	/	/
140(5700 MHz)	11.94	11.53	11.15	11.63	11.35	11.68	11.50	11.69
149(5745 MHz)	11.50	11.04	11.20	10.73	11.18	11.49	11.30	11.45
153(5765 MHz)	10.89	/	/	/	/	/	/	/
157(5785 MHz)	11.21	/	/	/	/	/	/	/
161(5805 MHz)	10.76	/	/	/	/	/	/	/
165(5825 MHz)	11.07	/	/	/	/	/	/	/

802.11n (dBm) - HT40 (5G)

Channel/data rate	MCS0	MCS1	MCS2	MCS3	MCS4	MCS5	MCS6	MCS7
38(5190 MHz)	11.16	9.83	10.02	9.49	10.01	9.58	10.35	11.06
46(5230 MHz)	11.06	/	/	/	/	/	/	/
54(5270 MHz)	11.42	11.22	11.15	10.93	10.94	11.37	11.00	11.41
62(5310 MHz)	11.24	/	/	/	/	/	/	/
102(5510 MHz)	11.51	/	/	/	/	/	/	/
110(5550 MHz)	11.63	11.21	11.18	10.91	11.16	11.62	11.47	11.53
118(5590 MHz)	10.86	/	/	/	/	/	/	/
126(5630 MHz)	11.01	/	/	/	/	/	/	/
134(5670 MHz)	10.30	/	/	/	/	/	/	/
151(5755 MHz)	10.93	/	/	/	/	/	/	/
159(5795 MHz)	11.35	11.05	11.09	10.75	10.76	11.33	11.13	11.34

## 12 Simultaneous TX SAR Considerations

### 12.1 Introduction

The following procedures adopted from “FCC SAR Considerations for Cell Phones with Multiple Transmitters” are applicable to handsets with built-in unlicensed transmitters such as 802.11 a/b/g and Bluetooth devices which may simultaneously transmit with the licensed transmitter.

For this device, the BT and Wi-Fi can transmit simultaneous with other transmitters.

### 12.2 Transmit Antenna Separation Distances

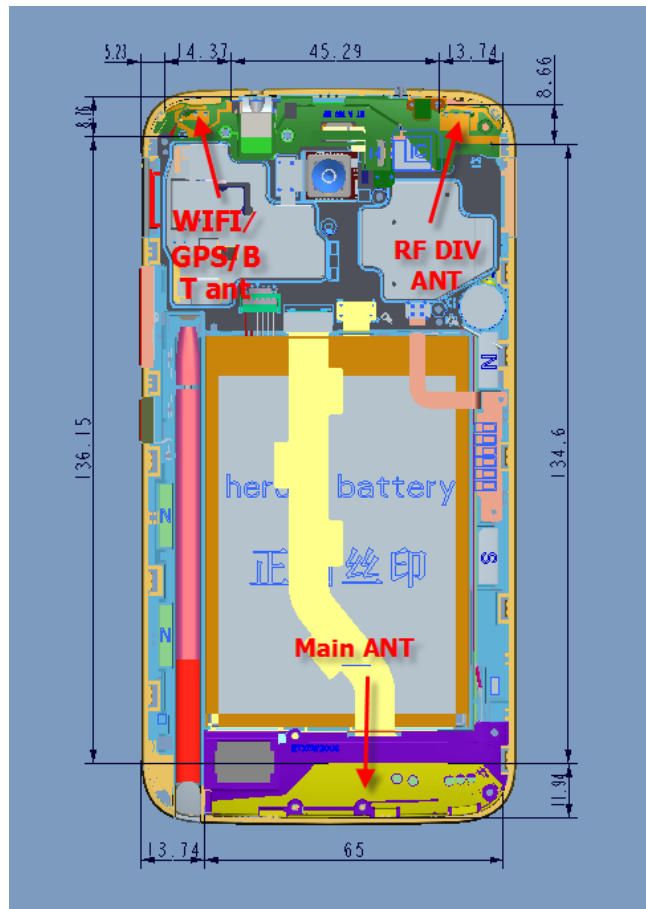

Picture 12.1 Antenna Locations

### 12.3 SAR Measurement Positions

According to the KDB941225 D06 Hot Spot SAR v01, the edges with less than 2.5 cm distance to the antennas need to be tested for SAR.

SAR measurement positions						
Mode	Front	Rear	Left edge	Right edge	Top edge	Bottom edge
Main antenna	Yes	Yes	Yes	Yes	No	Yes
WLAN	Yes	Yes	No	Yes	Yes	No

## 12.4 Standalone SAR Test Exclusion Considerations

Standalone 1-g head or body SAR evaluation by measurement or numerical simulation is not required when the corresponding SAR Exclusion Threshold condition, listed below, is satisfied. The 1-g SAR test exclusion threshold for 100 MHz to 6 GHz at test separation distances  $\leq 50$  mm are determined by:

$[(\text{max. power of channel, including tune-up tolerance, mW}) / (\text{min. test separation distance, mm})] \cdot [\sqrt{f(\text{GHz})}] \leq 3.0$  for 1-g SAR, where

- $f(\text{GHz})$  is the RF channel transmit frequency in GHz
- Power and distance are rounded to the nearest mW and mm before calculation
- The result is rounded to one decimal place for comparison

**Table 12.1: Standalone SAR test exclusion considerations**

Band/Mode	F(GHz)	Position	SAR test exclusion threshold (mW)	RF output power		SAR test exclusion
				dBm	mW	
Bluetooth	2.441	Head	9.60	7.74	5.94	Yes
		Body	19.20	7.74	5.94	Yes
2.4GHz WLAN 802.11 b	2.45	Head	9.58	18.34	68.23	No
		Body	19.17	18.34	68.23	No
WLAN 5GHz	5.2	Head	6.58	12.60	18.20	No
		Body	13.16	12.60	18.20	No
	5.3	Head	6.52	12.56	18.03	No
		Body	13.03	12.56	18.03	No
	5.6	Head	6.34	12.86	19.32	No
		Body	12.68	12.86	19.32	No
	5.8	Head	6.23	12.58	18.11	No
		Body	12.46	12.58	18.11	No



### 13 Evaluation of Simultaneous

**Table 13.1: The sum of reported SAR values for main antenna and WiFi**

	Position	Main antenna	WiFi	Sum
Maximum reported SAR value for Head	Left hand, Touch cheek	0.43	1.05	<b>1.48</b>
	Left hand, Tilt 15°	0.16	1.10	<b>1.26</b>
Maximum reported SAR value for Body	Front	0.98	0.15	<b>1.13</b>
	Top	/	0.27	<b>/</b>

**Table 13.2: The sum of reported SAR values for main antenna and BT**

	Position	Main antenna	BT	Sum
Maximum reported SAR value for Head	Left hand, Touch cheek	0.43	0.26 <sup>[1]</sup>	<b>0.69</b>
Maximum reported SAR value for Body	Front	0.98	0.13 <sup>[1]</sup>	<b>1.11</b>

[1] - Estimated SAR for Bluetooth (see the table 13.3)

**Table 13.3: Estimated SAR for Bluetooth**

Mode/Band	F (GHz)	Position	Distance (mm)	Upper limit of power *		Estimated <sub>1g</sub> (W/kg)
				dBm	mW	
Bluetooth	2.441	Head	5	8	6.31	0.26
Bluetooth	2.441	Body	10	8	6.31	0.13

\* - Maximum possible output power declared by manufacturer

When standalone SAR test exclusion applies to an antenna that transmits simultaneously with other antennas, the standalone SAR must be estimated according to following to determine simultaneous transmission SAR test exclusion:

(max. power of channel, including tune-up tolerance, mW)/(min. test separation distance, mm) · [√f(GHz)/x] W/kg for test separation distances ≤ 50 mm;

where x = 7.5 for 1-g SAR.

When the minimum test separation distance is < 5 mm, a distance of 5 mm is applied to determine SAR test exclusion

#### Conclusion:

According to the above tables, the sum of reported SAR values is < 1.6W/kg. So the simultaneous transmission SAR with volume scans is not required.

## 14 SAR Test Result

It is determined by user manual for the distance between the EUT and the phantom bottom.  
The distance is 10mm and just applied to the condition of body worn accessory.

It is performed for all SAR measurements with area scan based 1-g SAR estimation (Fast SAR). A zoom scan measurement is added when the estimated 1-g SAR is the highest measured SAR in each exposure configuration, wireless mode and frequency band combination or more than 1.2W/kg.

The calculated SAR is obtained by the following formula:

$$\text{Reported SAR} = \text{Measured SAR} \times 10^{(P_{\text{Target}} - P_{\text{Measured}})/10}$$

Where  $P_{\text{Target}}$  is the power of manufacturing upper limit;  
 $P_{\text{Measured}}$  is the measured power in chapter 11.

**Table 14.1: Duty Cycle**

Mode	Duty Cycle
Speech for GSM850/1900	1:8.3
GPRS&EGPRS for GSM850/1900	1:4
WCDMA&LTE&WiFi	1:1

### 14.1 SAR results for Fast SAR

According to the client request, we'll perform the head measurement in all bands without the flip cover and retest on highest value point with the flip cover in each band. Then, repeat the measurement in the Body test.

**Table 14.2: SAR Values (GSM 850 MHz Band - Head)**

Frequency		Side	Test Position	Figure No.	Ambient Temperature: 22.3 °C		Liquid Temperature: 21.8 °C		Measured SAR(1g) (W/kg)	Reported SAR(1g) (W/kg)	Power Drift (dB)
MHz	Ch.				Conducted Power (dBm)	Max. tune-up Power (dBm)	Measured SAR(10g) (W/kg)	Reported SAR(10g) (W/kg)			
848.8	251	Left	Touch	/	32.70	33.3	0.105	<b>0.12</b>	0.134	<b>0.15</b>	0.17
836.6	190	Left	Touch	/	32.73	33.3	0.092	<b>0.10</b>	0.131	<b>0.15</b>	0.09
824.2	128	Left	Touch	/	32.72	33.3	0.071	<b>0.08</b>	0.100	<b>0.11</b>	0.00
848.8	251	Left	Tilt	/	32.70	33.3	0.060	<b>0.07</b>	0.084	<b>0.10</b>	0.09
836.6	190	Left	Tilt	/	32.73	33.3	0.059	<b>0.07</b>	0.082	<b>0.09</b>	0.08
824.2	128	Left	Tilt	/	32.72	33.3	0.050	<b>0.06</b>	0.069	<b>0.08</b>	0.14
848.8	251	Right	Touch	/	32.70	33.3	0.138	<b>0.16</b>	0.177	<b>0.20</b>	0.14
836.6	190	Right	Touch	/	32.73	33.3	0.102	<b>0.12</b>	0.144	<b>0.16</b>	0.16
824.2	128	Right	Touch	/	32.72	33.3	0.090	<b>0.10</b>	0.128	<b>0.15</b>	0.05
848.8	251	Right	Tilt	/	32.70	33.3	0.060	<b>0.07</b>	0.084	<b>0.10</b>	0.07
836.6	190	Right	Tilt	/	32.73	33.3	0.056	<b>0.06</b>	0.079	<b>0.09</b>	0.15
824.2	128	Right	Tilt	/	32.72	33.3	0.053	<b>0.06</b>	0.074	<b>0.08</b>	0.15

Flip cover											
Frequency		Side	Test Position	Flip cover	Conducted Power (dBm)	Max. tune-up Power (dBm)	Measured SAR(10g) (W/kg)	Reported SAR(10g) (W/kg)	Measured SAR(1g) (W/kg)	Reported SAR(1g) (W/kg)	Power Drift (dB)
MHz	Ch.										
848.8	251	Right	Touch	1 Fig.1	32.70	33.3	0.153	<b>0.18</b>	0.199	<b>0.23</b>	-0.15
836.6	190	Right	Touch	1	32.73	33.3	0.115	<b>0.13</b>	0.162	<b>0.18</b>	0.12
824.2	128	Right	Touch	1	32.72	33.3	0.110	<b>0.13</b>	0.156	<b>0.18</b>	0.17
848.8	251	Right	Touch	2	32.70	33.3	0.117	<b>0.13</b>	0.165	<b>0.19</b>	0.15
848.8	251	Right	Touch	3	32.70	33.3	0.122	<b>0.14</b>	0.173	<b>0.20</b>	0.06

Note: the detail of Flip cover is presented in section 4.4.

**Table 14.3: SAR Values (GSM 850 MHz Band - Body)**

Ambient Temperature: 22.3 °C      Liquid Temperature: 21.8 °C											
Frequency		Mode (number of timeslots)	Test Position	Figure No.	Conducted Power (dBm)	Max. tune-up Power (dBm)	Measured SAR(10g) (W/kg)	Reported SAR(10g) (W/kg)	Measured SAR(1g) (W/kg)	Reported SAR(1g) (W/kg)	Power Drift (dB)
MHz	Ch.										
836.6	190	GPRS (2)	Front	/	31.09	31.3	0.117	<b>0.12</b>	0.165	<b>0.17</b>	0.01
848.8	251	GPRS (2)	Rear	Fig.2	31.10	31.3	0.220	<b>0.23</b>	0.399	<b>0.42</b>	-0.03
836.6	190	GPRS (2)	Rear	/	31.09	31.3	0.236	<b>0.25</b>	0.334	<b>0.35</b>	-0.12
824.2	128	GPRS (2)	Rear	/	31.12	31.3	0.221	<b>0.23</b>	0.311	<b>0.32</b>	-0.07
836.6	190	GPRS (2)	Left	/	31.09	31.3	0.097	<b>0.10</b>	0.144	<b>0.15</b>	0.02
836.6	190	GPRS (2)	Right	/	31.09	31.3	0.144	<b>0.15</b>	0.214	<b>0.22</b>	-0.04
836.6	190	GPRS (2)	Bottom	/	31.09	31.3	0.037	<b>0.04</b>	0.056	<b>0.06</b>	-0.08
848.8	251	EGPRS (2)	Rear	/	31.05	31.3	0.227	<b>0.24</b>	0.359	<b>0.38</b>	0.05
848.8	251	Speech	Rear Headset1	/	32.70	33.3	0.165	<b>0.19</b>	0.237	<b>0.27</b>	0.06
848.8	251	Speech	Rear Headset2	/	32.70	33.3	0.163	<b>0.19</b>	0.234	<b>0.27</b>	0.03
Flip cover											
Frequency		Mode (number of timeslots)	Test Position	Flip cover	Conducted Power (dBm)	Max. tune-up Power (dBm)	Measured SAR(10g) (W/kg)	Reported SAR(10g) (W/kg)	Measured SAR(1g) (W/kg)	Reported SAR(1g) (W/kg)	Power Drift (dB)
MHz	Ch.										
848.8	251	GPRS (2)	Rear	1	31.10	31.3	0.194	<b>0.20</b>	0.351	<b>0.37</b>	0.04
848.8	251	GPRS (2)	Rear	2	31.10	31.3	0.165	<b>0.17</b>	0.301	<b>0.32</b>	0.01
848.8	251	GPRS (2)	Rear	3	31.10	31.3	0.146	<b>0.15</b>	0.264	<b>0.28</b>	-0.02

Note1: The distance between the EUT and the phantom bottom is 10mm.

Note2: Headset1 is CCA0001A10C9, Headset2 is CCB3001A15C4.

Note3: the detail of Flip cover is presented in section 4.4.

**Table 14.4: SAR Values (GSM 1900 MHz Band - Head)**

Ambient Temperature: 22.1 °C						Liquid Temperature: 21.6 °C					
Frequency		Side	Test Position	Figure No.	Conducted Power (dBm)	Max. tune-up Power (dBm)	Measured SAR(10g) (W/kg)	Reported SAR(10g) (W/kg)	Measured SAR(1g) (W/kg)	Reported SAR(1g) (W/kg)	Power Drift (dB)
MHz	Ch.										
1909.8	810	Left	Touch	Fig.3	30.16	30.3	0.107	<b>0.11</b>	0.172	<b>0.18</b>	0.16
1880	661	Left	Touch	/	30.07	30.3	0.061	<b>0.06</b>	0.104	<b>0.11</b>	0.19
1850.2	512	Left	Touch	/	29.99	30.3	0.057	<b>0.06</b>	0.097	<b>0.10</b>	0.13
1909.8	810	Left	Tilt	/	30.16	30.3	0.034	<b>0.03</b>	0.061	<b>0.06</b>	0.00
1880	661	Left	Tilt	/	30.07	30.3	0.026	<b>0.03</b>	0.046	<b>0.05</b>	0.09
1850.2	512	Left	Tilt	/	29.99	30.3	0.027	<b>0.03</b>	0.050	<b>0.05</b>	-0.11
1909.8	810	Right	Touch	/	30.16	30.3	0.043	<b>0.04</b>	0.072	<b>0.07</b>	0.18
1880	661	Right	Touch	/	30.07	30.3	0.032	<b>0.03</b>	0.055	<b>0.06</b>	0.18
1850.2	512	Right	Touch	/	29.99	30.3	0.034	<b>0.04</b>	0.058	<b>0.06</b>	0.18
1909.8	810	Right	Tilt	/	30.16	30.3	0.030	<b>0.03</b>	0.053	<b>0.05</b>	-0.11
1880	661	Right	Tilt	/	30.07	30.3	0.021	<b>0.02</b>	0.039	<b>0.04</b>	0.10
1850.2	512	Right	Tilt	/	29.99	30.3	0.026	<b>0.03</b>	0.047	<b>0.05</b>	-0.10
Flip cover											
Frequency		Side	Test Position	Flip cover	Conducted Power (dBm)	Max. tune-up Power (dBm)	Measured SAR(10g) (W/kg)	Reported SAR(10g) (W/kg)	Measured SAR(1g) (W/kg)	Reported SAR(1g) (W/kg)	Power Drift (dB)
MHz	Ch.										
1909.8	810	Left	Touch	1	30.16	30.3	0.075	<b>0.08</b>	0.131	<b>0.14</b>	0.12
1909.8	810	Left	Touch	2	30.16	30.3	0.101	<b>0.10</b>	0.163	<b>0.17</b>	0.10
1909.8	810	Left	Touch	3	30.16	30.3	0.095	<b>0.10</b>	0.151	<b>0.16</b>	0.07

Note: the detail of Flip cover is presented in section 4.4.

**Table 14.5: SAR Values (GSM 1900 MHz Band - Body)**

Ambient Temperature: 22.1 °C						Liquid Temperature: 21.6 °C					
Frequency		Mode (number of timeslots)	Test Position	Figure No.	Conducted Power (dBm)	Max. tune-up Power (dBm)	Measured SAR(10g) (W/kg)	Reported SAR(10g) (W/kg)	Measured SAR(1g) (W/kg)	Reported SAR(1g) (W/kg)	Power Drift (dB)
MHz	Ch.										
1880	661	GPRS (2)	Front	/	28.17	28.3	0.120	<b>0.12</b>	0.202	<b>0.21</b>	-0.09
1880	661	GPRS (2)	Rear	/	28.17	28.3	0.186	<b>0.19</b>	0.331	<b>0.34</b>	0.00
1880	661	GPRS (2)	Left	/	28.17	28.3	0.120	<b>0.12</b>	0.210	<b>0.22</b>	0.02
1880	661	GPRS (2)	Right	/	28.17	28.3	0.048	<b>0.05</b>	0.082	<b>0.08</b>	0.10
1909.8	810	GPRS (2)	Bottom	Fig.4	28.29	28.3	0.280	<b>0.28</b>	0.536	<b>0.54</b>	-0.04
1880	661	GPRS (2)	Bottom	/	28.17	28.3	0.191	<b>0.20</b>	0.384	<b>0.40</b>	0.00
1850.2	512	GPRS (2)	Bottom	/	27.96	28.3	0.167	<b>0.18</b>	0.318	<b>0.34</b>	-0.02
1909.8	810	EGPRS (2)	Bottom	/	28.28	28.3	0.248	<b>0.25</b>	0.487	<b>0.49</b>	0.00
1909.8	810	Speech	Bottom Headset1	/	30.16	30.3	0.256	<b>0.26</b>	0.493	<b>0.51</b>	0.00
1909.8	810	Speech	Bottom Headset2	/	30.16	30.3	0.255	<b>0.26</b>	0.491	<b>0.51</b>	-0.09

Flip cover											
Frequency		Mode (number of timeslots)	Test Position	Flip cover	Conducted Power (dBm)	Max. tune-up Power (dBm)	Measured SAR(10g) (W/kg)	Reported SAR(10g) (W/kg)	Measured SAR(1g) (W/kg)	Reported SAR(1g) (W/kg)	Power Drift (dB)
MHz	Ch.										
1909.8	810	GPRS (2)	Bottom	1	28.29	28.3	0.258	<b>0.26</b>	0.518	<b>0.52</b>	-0.01
1909.8	810	GPRS (2)	Bottom	2	28.29	28.3	0.246	<b>0.25</b>	0.491	<b>0.49</b>	-0.05
1909.8	810	GPRS (2)	Bottom	3	28.29	28.3	0.231	<b>0.23</b>	0.439	<b>0.44</b>	-0.02

Note1: The distance between the EUT and the phantom bottom is 10mm.

Note2: Headset1 is CCA0001A10C9, Headset2 is CCB3001A15C4.

Note3: the detail of Flip cover is presented in section 4.4.

**Table 14.6: SAR Values (WCDMA 850 MHz Band - Head)**

Ambient Temperature: 22.3 °C      Liquid Temperature: 21.8 °C											
Frequency		Side	Test Position	Figure No.	Conducted Power (dBm)	Max. tune-up Power (dBm)	Measured SAR(10g) (W/kg)	Reported SAR(10g) (W/kg)	Measured SAR(1g) (W/kg)	Reported SAR(1g) (W/kg)	Power Drift (dB)
MHz	Ch.										
846.6	4233	Left	Touch	/	23.50	24.0	0.096	<b>0.11</b>	0.135	<b>0.15</b>	0.08
836.4	4182	Left	Touch	/	23.47	24.0	0.116	<b>0.13</b>	0.147	<b>0.17</b>	0.18
826.4	4132	Left	Touch	/	23.50	24.0	0.085	<b>0.10</b>	0.119	<b>0.13</b>	0.13
846.6	4233	Left	Tilt	/	23.50	24.0	0.061	<b>0.07</b>	0.085	<b>0.10</b>	-0.15
836.4	4182	Left	Tilt	/	23.47	24.0	0.064	<b>0.07</b>	0.089	<b>0.10</b>	0.03
826.4	4132	Left	Tilt	/	23.50	24.0	0.057	<b>0.06</b>	0.079	<b>0.09</b>	0.10
846.6	4233	Right	Touch	/	23.50	24.0	0.127	<b>0.14</b>	0.164	<b>0.18</b>	0.15
836.4	4182	Right	Touch	/	23.47	24.0	0.114	<b>0.13</b>	0.161	<b>0.18</b>	-0.05
826.4	4132	Right	Touch	/	23.50	24.0	0.104	<b>0.12</b>	0.147	<b>0.16</b>	0.17
846.6	4233	Right	Tilt	/	23.50	24.0	0.066	<b>0.07</b>	0.092	<b>0.10</b>	-0.17
836.4	4182	Right	Tilt	/	23.47	24.0	0.069	<b>0.08</b>	0.096	<b>0.11</b>	0.18
826.4	4132	Right	Tilt	/	23.50	24.0	0.069	<b>0.08</b>	0.097	<b>0.11</b>	0.19
Flip cover											
Frequency		Side	Test Position	Flip cover	Conducted Power (dBm)	Max. tune-up Power (dBm)	Measured SAR(10g) (W/kg)	Reported SAR(10g) (W/kg)	Measured SAR(1g) (W/kg)	Reported SAR(1g) (W/kg)	Power Drift (dB)
MHz	Ch.										
846.6	4233	Right	Touch	1 Fig.5	23.50	24.0	0.146	<b>0.16</b>	0.188	<b>0.21</b>	-0.16
836.4	4182	Right	Touch	1	23.47	24.0	0.122	<b>0.14</b>	0.171	<b>0.19</b>	0.09
826.4	4132	Right	Touch	1	23.50	24.0	0.105	<b>0.12</b>	0.148	<b>0.17</b>	0.17
846.6	4233	Right	Touch	2	23.50	24.0	0.113	<b>0.13</b>	0.159	<b>0.18</b>	0.10
846.6	4233	Right	Touch	3	23.50	24.0	0.120	<b>0.13</b>	0.169	<b>0.19</b>	0.19

Note: the detail of Flip cover is presented in section 4.4.

**Table 14.7: SAR Values (WCDMA 850 MHz Band - Body)**

Ambient Temperature: 22.3 °C						Liquid Temperature: 21.8 °C				
Frequency		Test Position	Figure No.	Conducted Power (dBm)	Max. tune-up Power (dBm)	Measured SAR(10g) (W/kg)	Reported SAR(10g) (W/kg)	Measured SAR(1g) (W/kg)	Reported SAR(1g) (W/kg)	Power Drift (dB)
MHz	Ch.									
836.4	4182	Front	/	23.47	24.0	0.115	<b>0.13</b>	0.163	<b>0.18</b>	0.01
846.6	4233	Rear	/	23.50	24.0	0.175	<b>0.20</b>	0.247	<b>0.28</b>	-0.04
836.4	4182	Rear	/	23.47	24.0	0.178	<b>0.20</b>	0.251	<b>0.28</b>	-0.15
826.4	4132	Rear	Fig.6	23.50	24.0	0.200	<b>0.22</b>	0.255	<b>0.29</b>	0.02
836.4	4182	Left	/	23.47	24.0	0.096	<b>0.11</b>	0.142	<b>0.16</b>	0.02
836.4	4182	Right	/	23.47	24.0	0.142	<b>0.16</b>	0.210	<b>0.24</b>	-0.03
836.4	4182	Bottom	/	23.47	24.0	0.037	<b>0.04</b>	0.055	<b>0.06</b>	-0.08
826.4	4132	Rear Headset1	/	23.50	24.0	0.186	<b>0.21</b>	0.222	<b>0.25</b>	-0.07
826.4	4132	Rear Headset2	/	23.50	24.0	0.192	<b>0.22</b>	0.232	<b>0.26</b>	0.05
Flip cover										
Frequency		Test Position	Flip cover	Conducted Power (dBm)	Max. tune-up Power (dBm)	Measured SAR(10g) (W/kg)	Reported SAR(10g) (W/kg)	Measured SAR(1g) (W/kg)	Reported SAR(1g) (W/kg)	Power Drift (dB)
MHz	Ch.									
826.4	4132	Rear	1	23.50	24.0	0.167	<b>0.19</b>	0.235	<b>0.26</b>	0.02
826.4	4132	Rear	2	23.50	24.0	0.158	<b>0.18</b>	0.229	<b>0.26</b>	0.12
826.4	4132	Rear	3	23.50	24.0	0.164	<b>0.18</b>	0.223	<b>0.25</b>	-0.07

Note1: The distance between the EUT and the phantom bottom is 10mm.

Note2: Headset1 is CCA0001A10C9, Headset2 is CCB3001A15C4.

Note3: the detail of Flip cover is presented in section 4.4.

**Table 14.8: SAR Values (WCDMA 1900 MHz Band - Head)**

Ambient Temperature: 22.1 °C						Liquid Temperature: 21.6 °C					
Frequency		Side	Test Position	Figure No.	Conducted Power (dBm)	Max. tune-up Power (dBm)	Measured SAR(10g) (W/kg)	Reported SAR(10g) (W/kg)	Measured SAR(1g) (W/kg)	Reported SAR(1g) (W/kg)	Power Drift (dB)
MHz	Ch.										
1907.6	9538	Left	Touch	/	23.27	24.0	0.095	<b>0.11</b>	0.163	<b>0.19</b>	0.10
1880	9400	Left	Touch	/	23.20	24.0	0.103	<b>0.12</b>	0.174	<b>0.21</b>	0.16
1852.4	9262	Left	Touch	Fig.7	23.11	24.0	0.126	<b>0.15</b>	0.199	<b>0.24</b>	0.10
1907.6	9538	Left	Tilt	/	23.27	24.0	0.035	<b>0.04</b>	0.061	<b>0.07</b>	-0.18
1880	9400	Left	Tilt	/	23.20	24.0	0.038	<b>0.05</b>	0.065	<b>0.08</b>	0.07
1852.4	9262	Left	Tilt	/	23.11	24.0	0.040	<b>0.05</b>	0.069	<b>0.09</b>	0.02
1907.6	9538	Right	Touch	/	23.27	24.0	0.047	<b>0.06</b>	0.078	<b>0.09</b>	0.06
1880	9400	Right	Touch	/	23.20	24.0	0.047	<b>0.06</b>	0.082	<b>0.10</b>	0.11
1852.4	9262	Right	Touch	/	23.11	24.0	0.055	<b>0.07</b>	0.086	<b>0.11</b>	0.14
1907.6	9538	Right	Tilt	/	23.27	24.0	0.036	<b>0.04</b>	0.064	<b>0.08</b>	0.15
1880	9400	Right	Tilt	/	23.20	24.0	0.039	<b>0.05</b>	0.071	<b>0.08</b>	0.09
1852.4	9262	Right	Tilt	/	23.11	24.0	0.048	<b>0.06</b>	0.086	<b>0.11</b>	-0.01

Flip cover											
Frequency		Side	Test Position	Flip cover	Conducted Power (dBm)	Max. tune-up Power (dBm)	Measured SAR(10g) (W/kg)	Reported SAR(10g) (W/kg)	Measured SAR(1g) (W/kg)	Reported SAR(1g) (W/kg)	Power Drift (dB)
MHz	Ch.										
1852.4	9262	Left	Touch	1	23.11	24.0	0.089	<b>0.11</b>	0.153	<b>0.19</b>	0.19
1852.4	9262	Left	Touch	2	23.11	24.0	0.090	<b>0.11</b>	0.153	<b>0.19</b>	0.13
1852.4	9262	Left	Touch	3	23.11	24.0	0.094	<b>0.12</b>	0.163	<b>0.20</b>	0.10

Note: the detail of Flip cover is presented in section 4.4.

**Table 14.9: SAR Values (WCDMA 1900 MHz Band - Body)**

Ambient Temperature: 22.1 °C												Liquid Temperature: 21.6 °C											
Frequency		Test Position	Figure No.	Conducted Power (dBm)	Max. tune-up Power (dBm)	Measured SAR(10g) (W/kg)	Reported SAR(10g) (W/kg)	Measured SAR(1g) (W/kg)	Reported SAR(1g) (W/kg)	Power Drift (dB)													
MHz	Ch.																						
1880	9400	Front	/	23.20	24.0	0.168	<b>0.20</b>	0.313	<b>0.38</b>	0.06													
1907.6	9538	Rear	Fig.8	23.27	24.0	0.284	<b>0.34</b>	0.513	<b>0.61</b>	0.04													
1880	9400	Rear	/	23.20	24.0	0.252	<b>0.30</b>	0.496	<b>0.60</b>	-0.09													
1852.4	9262	Rear	/	23.11	24.0	0.244	<b>0.30</b>	0.428	<b>0.53</b>	0.06													
1880	9400	Left	/	23.20	24.0	0.124	<b>0.15</b>	0.216	<b>0.26</b>	0.06													
1880	9400	Right	/	23.20	24.0	0.062	<b>0.07</b>	0.105	<b>0.13</b>	0.18													
1880	9400	Bottom	/	23.20	24.0	0.209	<b>0.25</b>	0.394	<b>0.47</b>	0.01													
1907.6	9538	Rear Headset1	/	23.27	24.0	0.266	<b>0.31</b>	0.482	<b>0.57</b>	0.01													
1907.6	9538	Rear Headset2	/	23.27	24.0	0.260	<b>0.31</b>	0.480	<b>0.57</b>	0.03													
Flip cover																							
Frequency		Test Position	Flip cover	Conducted Power (dBm)	Max. tune-up Power (dBm)	Measured SAR(10g) (W/kg)	Reported SAR(10g) (W/kg)	Measured SAR(1g) (W/kg)	Reported SAR(1g) (W/kg)	Power Drift (dB)													
MHz	Ch.																						
1907.6	9538	Rear	1	23.27	24.0	0.207	<b>0.24</b>	0.366	<b>0.43</b>	0.07													
1907.6	9538	Rear	2	23.27	24.0	0.188	<b>0.22</b>	0.344	<b>0.41</b>	0.07													
1907.6	9538	Rear	3	23.27	24.0	0.206	<b>0.24</b>	0.365	<b>0.43</b>	0.00													

Note1: The distance between the EUT and the phantom bottom is 10mm.

Note2: Headset1 is CCA0001A10C9, Headset2 is CCB3001A15C4.

Note3: the detail of Flip cover is presented in section 4.4.

**Table 14.10: SAR Values (LTE Band2 - Head)**

Ambient Temperature: 22.1 °C      Liquid Temperature: 21.6 °C

Frequency		Mode	Side	Test Position	Figure No.	Conducted Power (dBm)	Max. tune-up Power (dBm)	Measured SAR(10g) (W/kg)	Reported SAR(10g) (W/kg)	Measured SAR(1g) (W/kg)	Reported SAR(1g) (W/kg)	Power Drift (dB)
MHz	Ch.											
1900	19100	1RB_Mid	Left	Touch	Fig.9	23.38	23.5	0.084	<b>0.09</b>	0.131	<b>0.13</b>	-0.13
1900	19100	1RB_Mid	Left	Tilt	/	23.38	23.5	0.034	<b>0.03</b>	0.060	<b>0.06</b>	0.13
1900	19100	1RB_Mid	Right	Touch	/	23.38	23.5	0.041	<b>0.04</b>	0.063	<b>0.06</b>	0.18
1900	19100	1RB_Mid	Right	Tilt	/	23.38	23.5	0.032	<b>0.03</b>	0.057	<b>0.06</b>	0.19
1900	19100	50RB_Low	Left	Touch	/	22.24	22.5	0.054	<b>0.06</b>	0.090	<b>0.10</b>	0.13
1900	19100	50RB_Low	Left	Tilt	/	22.24	22.5	0.027	<b>0.03</b>	0.047	<b>0.05</b>	0.14
1900	19100	50RB_Low	Right	Touch	/	22.24	22.5	0.029	<b>0.03</b>	0.048	<b>0.05</b>	0.13
1900	19100	50RB_Low	Right	Tilt	/	22.24	22.5	0.025	<b>0.03</b>	0.045	<b>0.05</b>	0.14
Flip cover												
Frequency		Mode	Side	Test Position	Flip cover	Conducted Power (dBm)	Max. tune-up Power (dBm)	Measured SAR(10g) (W/kg)	Reported SAR(10g) (W/kg)	Measured SAR(1g) (W/kg)	Reported SAR(1g) (W/kg)	Power Drift (dB)
MHz	Ch.											
1900	19100	1RB_Mid	Left	Touch	1	23.38	23.5	0.082	<b>0.08</b>	0.130	<b>0.13</b>	0.19
1900	19100	1RB_Mid	Left	Touch	2	23.38	23.5	0.081	<b>0.08</b>	0.129	<b>0.13</b>	0.16
1900	19100	1RB_Mid	Left	Touch	3	23.38	23.5	0.082	<b>0.08</b>	0.130	<b>0.13</b>	0.11

Note1: The LTE mode is QPSK\_20MHz.

Note2: the detail of Flip cover is presented in section 4.4.

**Table 14.11: SAR Values (LTE Band2 - Body)**

Ambient Temperature: 22.1 °C      Liquid Temperature: 21.6 °C

Frequency		Mode	Test Position	Figure No.	Conducted Power (dBm)	Max. tune-up Power (dBm)	Measured SAR(10g) (W/kg)	Reported SAR(10g) (W/kg)	Measured SAR(1g) (W/kg)	Reported SAR(1g) (W/kg)	Power Drift (dB)
MHz	Ch.										
1900	19100	1RB_Mid	Front	/	23.38	23.5	0.161	<b>0.17</b>	0.297	<b>0.31</b>	0.16
1900	19100	1RB_Mid	Rear	Fig.10	23.38	23.5	0.269	<b>0.28</b>	0.487	<b>0.50</b>	-0.11
1900	19100	1RB_Mid	Left	/	23.38	23.5	0.114	<b>0.12</b>	0.203	<b>0.21</b>	0.10
1900	19100	1RB_Mid	Right	/	23.38	23.5	0.054	<b>0.06</b>	0.096	<b>0.10</b>	0.15
1900	19100	1RB_Mid	Bottom	/	23.38	23.5	0.227	<b>0.23</b>	0.444	<b>0.46</b>	-0.01
1900	19100	50RB_Low	Front	/	22.24	22.5	0.120	<b>0.13</b>	0.207	<b>0.22</b>	0.13
1900	19100	50RB_Low	Rear	/	22.24	22.5	0.206	<b>0.22</b>	0.380	<b>0.40</b>	0.18
1900	19100	50RB_Low	Left	/	22.24	22.5	0.091	<b>0.10</b>	0.160	<b>0.17</b>	0.04
1900	19100	50RB_Low	Right	/	22.24	22.5	0.040	<b>0.04</b>	0.072	<b>0.08</b>	0.17
1900	19100	50RB_Low	Bottom	/	22.24	22.5	0.171	<b>0.18</b>	0.334	<b>0.35</b>	0.05



Flip cover											
Frequency		Mode	Test Position	Flip cover	Conducted Power (dBm)	Max. tune-up Power (dBm)	Measured SAR(10g) (W/kg)	Reported SAR(10g) (W/kg)	Measured SAR(1g) (W/kg)	Reported SAR(1g) (W/kg)	Power Drift (dB)
MHz	Ch.										
1900	19100	1RB_Mid	Rear	1	23.38	23.5	0.180	<b>0.19</b>	0.324	<b>0.33</b>	0.00
1900	19100	1RB_Mid	Rear	2	23.38	23.5	0.181	<b>0.19</b>	0.326	<b>0.34</b>	0.12
1900	19100	1RB_Mid	Rear	3	23.38	23.5	0.178	<b>0.18</b>	0.323	<b>0.33</b>	0.03

Note1: The distance between the EUT and the phantom bottom is 10mm.

Note2: The LTE mode is QPSK\_20MHz.

Note3: the detail of Flip cover is presented in section 4.4.

**Table 14.12: SAR Values (LTE Band4 - Head)**

Ambient Temperature: 22.3 °C						Liquid Temperature: 21.8 °C						
Frequency		Mode	Side	Test Position	Figure No.	Conducted Power (dBm)	Max. tune-up Power (dBm)	Measured SAR(10g) (W/kg)	Reported SAR(10g) (W/kg)	Measured SAR(1g) (W/kg)	Reported SAR(1g) (W/kg)	Power Drift (dB)
MHz	Ch.											
1720	20050	1RB_Mid	Left	Touch	Fig.11	23.39	23.5	0.151	<b>0.15</b>	0.231	<b>0.24</b>	0.01
1720	20050	1RB_Mid	Left	Tilt	/	23.39	23.5	0.052	<b>0.05</b>	0.089	<b>0.09</b>	0.10
1720	20050	1RB_Mid	Right	Touch	/	23.39	23.5	0.081	<b>0.08</b>	0.121	<b>0.12</b>	-0.01
1720	20050	1RB_Mid	Right	Tilt	/	23.39	23.5	0.053	<b>0.05</b>	0.093	<b>0.10</b>	0.04
1732.5	20175	50RB_Low	Left	Touch	/	22.35	22.5	0.105	<b>0.11</b>	0.174	<b>0.18</b>	0.13
1732.5	20175	50RB_Low	Left	Tilt	/	22.35	22.5	0.039	<b>0.04</b>	0.067	<b>0.07</b>	0.09
1732.5	20175	50RB_Low	Right	Touch	/	22.35	22.5	0.061	<b>0.06</b>	0.105	<b>0.11</b>	0.11
1732.5	20175	50RB_Low	Right	Tilt	/	22.35	22.5	0.043	<b>0.04</b>	0.077	<b>0.08</b>	0.15
Flip cover												
Frequency		Mode	Side	Test Position	Flip cover	Conducted Power (dBm)	Max. tune-up Power (dBm)	Measured SAR(10g) (W/kg)	Reported SAR(10g) (W/kg)	Measured SAR(1g) (W/kg)	Reported SAR(1g) (W/kg)	Power Drift (dB)
MHz	Ch.											
1720	20050	1RB_Mid	Left	Touch	1	23.39	23.5	0.129	<b>0.13</b>	0.215	<b>0.22</b>	-0.10
1720	20050	1RB_Mid	Left	Touch	2	23.39	23.5	0.132	<b>0.14</b>	0.220	<b>0.23</b>	0.18
1720	20050	1RB_Mid	Left	Touch	3	23.39	23.5	0.143	<b>0.15</b>	0.229	<b>0.23</b>	0.12

Note1: The LTE mode is QPSK\_20MHz.

Note2: the detail of Flip cover is presented in section 4.4.

**Table 14.13: SAR Values (LTE Band4 - Body)**

Ambient Temperature: 22.3 °C						Liquid Temperature: 21.8 °C					
Frequency		Mode	Test Position	Figure No.	Conducted Power (dBm)	Max. tune-up Power (dBm)	Measured SAR(10g) (W/kg)	Reported SAR(10g) (W/kg)	Measured SAR(1g) (W/kg)	Reported SAR(1g) (W/kg)	Power Drift (dB)
MHz	Ch.										
1720	20050	1RB_Mid	Front	/	23.39	23.5	0.186	<b>0.19</b>	0.305	<b>0.31</b>	0.05
1720	20050	1RB_Mid	Rear	Fig.12	23.39	23.5	0.263	<b>0.27</b>	0.396	<b>0.41</b>	-0.01
1720	20050	1RB_Mid	Left	/	23.39	23.5	0.160	<b>0.16</b>	0.273	<b>0.28</b>	-0.13
1720	20050	1RB_Mid	Right	/	23.39	23.5	0.117	<b>0.12</b>	0.120	<b>0.12</b>	0.10
1720	20050	1RB_Mid	Bottom	/	23.39	23.5	0.161	<b>0.17</b>	0.294	<b>0.30</b>	-0.01
1732.5	20175	50RB_Low	Front	/	22.35	22.5	0.159	<b>0.16</b>	0.252	<b>0.26</b>	0.08
1732.5	20175	50RB_Low	Rear	/	22.35	22.5	0.207	<b>0.21</b>	0.324	<b>0.34</b>	0.08
1732.5	20175	50RB_Low	Left	/	22.35	22.5	0.130	<b>0.13</b>	0.222	<b>0.23</b>	-0.16
1732.5	20175	50RB_Low	Right	/	22.35	22.5	0.071	<b>0.07</b>	0.119	<b>0.12</b>	0.17
1732.5	20175	50RB_Low	Bottom	/	22.35	22.5	0.139	<b>0.14</b>	0.255	<b>0.26</b>	0.04
Flip cover											
Frequency		Mode	Test Position	Flip cover	Conducted Power (dBm)	Max. tune-up Power (dBm)	Measured SAR(10g) (W/kg)	Reported SAR(10g) (W/kg)	Measured SAR(1g) (W/kg)	Reported SAR(1g) (W/kg)	Power Drift (dB)
MHz	Ch.										
1720	20050	1RB_Mid	Rear	1	23.39	23.5	0.224	<b>0.23</b>	0.361	<b>0.37</b>	0.01
1720	20050	1RB_Mid	Rear	2	23.39	23.5	0.285	<b>0.29</b>	0.291	<b>0.30</b>	0.10
1720	20050	1RB_Mid	Rear	3	23.39	23.5	0.225	<b>0.23</b>	0.360	<b>0.37</b>	0.05

Note1: The distance between the EUT and the phantom bottom is 10mm.

Note2: The LTE mode is QPSK\_20MHz.

Note3: the detail of Flip cover is presented in section 4.4.

**Table 14.14: SAR Values (LTE Band7 - Head)**

Ambient Temperature: 22.2 °C						Liquid Temperature: 21.7 °C						
Frequency		Mode	Side	Test Position	Figure No.	Conducted Power (dBm)	Max. tune-up Power (dBm)	Measured SAR(10g) (W/kg)	Reported SAR(10g) (W/kg)	Measured SAR(1g) (W/kg)	Reported SAR(1g) (W/kg)	Power Drift (dB)
MHz	Ch.											
2560	21350	1RB_High	Left	Touch	Fig.13	22.88	23.0	0.225	<b>0.23</b>	0.418	<b>0.43</b>	0.18
2560	21350	1RB_High	Left	Tilt	/	22.88	23.0	0.086	<b>0.09</b>	0.153	<b>0.16</b>	0.14
2560	21350	1RB_High	Right	Touch	/	22.88	23.0	0.120	<b>0.12</b>	0.220	<b>0.23</b>	0.19
2560	21350	1RB_High	Right	Tilt	/	22.88	23.0	0.110	<b>0.11</b>	0.190	<b>0.20</b>	0.10
2560	21350	50RB_High	Left	Touch	/	22.00	22.0	0.213	<b>0.21</b>	0.396	<b>0.40</b>	0.11
2560	21350	50RB_High	Left	Tilt	/	22.00	22.0	0.066	<b>0.07</b>	0.117	<b>0.12</b>	0.13
2560	21350	50RB_High	Right	Touch	/	22.00	22.0	0.091	<b>0.09</b>	0.171	<b>0.17</b>	0.18
2560	21350	50RB_High	Right	Tilt	/	22.00	22.0	0.081	<b>0.08</b>	0.144	<b>0.14</b>	0.11

**Flip cover**

Frequency		Mode	Side	Test Position	Flip cover	Conducted Power (dBm)	Max. tune-up Power (dBm)	Measured SAR(10g) (W/kg)	Reported SAR(10g) (W/kg)	Measured SAR(1g) (W/kg)	Reported SAR(1g) (W/kg)	Power Drift (dB)
MHz	Ch.											
2560	21350	1RB_High	Left	Touch	1	22.88	23.0	0.208	<b>0.21</b>	0.388	<b>0.40</b>	0.17
2560	21350	1RB_High	Left	Touch	2	22.88	23.0	0.198	<b>0.20</b>	0.357	<b>0.37</b>	0.14
2560	21350	1RB_High	Left	Touch	3	22.88	23.0	0.196	<b>0.20</b>	0.354	<b>0.36</b>	0.10

Note1: The LTE mode is QPSK\_20MHz.

Note2: the detail of Flip cover is presented in section 4.4.

**Table 14.15: SAR Values (LTE Band7 - Body)**

Ambient Temperature: 22.2 °C						Liquid Temperature: 21.7 °C					
Frequency		Mode	Test Position	Figure No.	Conducted Power (dBm)	Max. tune-up Power (dBm)	Measured SAR(10g) (W/kg)	Reported SAR(10g) (W/kg)	Measured SAR(1g) (W/kg)	Reported SAR(1g) (W/kg)	Power Drift (dB)
MHz	Ch.										
2560	21350	1RB_High	Front	Fig.14	22.88	23.0	0.507	<b>0.52</b>	0.958	<b>0.98</b>	-0.11
2535	21100	1RB_High	Front	/	22.71	23.0	0.486	<b>0.52</b>	0.920	<b>0.98</b>	0.10
2510	20850	1RB_High	Front	/	22.85	23.0	0.468	<b>0.48</b>	0.903	<b>0.93</b>	-0.12
2560	21350	1RB_High	Rear	/	22.88	23.0	0.447	<b>0.46</b>	0.845	<b>0.87</b>	0.01
2535	21100	1RB_High	Rear	/	22.71	23.0	0.435	<b>0.47</b>	0.821	<b>0.88</b>	-0.08
2510	20850	1RB_High	Rear	/	22.85	23.0	0.442	<b>0.46</b>	0.835	<b>0.86</b>	0.05
2560	21350	1RB_High	Left	/	22.88	23.0	0.395	<b>0.41</b>	0.768	<b>0.79</b>	0.01
2535	21100	1RB_High	Left	/	22.71	23.0	0.387	<b>0.41</b>	0.753	<b>0.80</b>	0.04
2510	20850	1RB_High	Left	/	22.85	23.0	0.390	<b>0.40</b>	0.758	<b>0.78</b>	-0.09
2560	21350	1RB_High	Right	/	22.88	23.0	0.021	<b>0.02</b>	0.038	<b>0.04</b>	-0.08
2560	21350	1RB_High	Bottom	/	22.88	23.0	0.312	<b>0.32</b>	0.586	<b>0.60</b>	0.06
2560	21350	50RB_High	Front	/	22.00	22.0	0.425	<b>0.43</b>	0.810	<b>0.81</b>	0.11
2535	21100	50RB_High	Front	/	21.60	22.0	0.396	<b>0.43</b>	0.754	<b>0.83</b>	-0.10
2510	20850	50RB_High	Front	/	21.69	22.0	0.401	<b>0.43</b>	0.765	<b>0.82</b>	0.08
2560	21350	50RB_High	Rear	/	22.00	22.0	0.362	<b>0.36</b>	0.684	<b>0.68</b>	0.04
2560	21350	50RB_High	Left	/	22.00	22.0	0.303	<b>0.30</b>	0.590	<b>0.59</b>	-0.02
2560	21350	50RB_High	Right	/	22.00	22.0	0.018	<b>0.02</b>	0.032	<b>0.03</b>	0.16
2560	21350	50RB_High	Bottom	/	22.00	22.0	0.233	<b>0.23</b>	0.437	<b>0.44</b>	0.06
2560	21350	100RB	Front	/	21.90	22.0	0.405	<b>0.41</b>	0.773	<b>0.79</b>	-0.03
2560	21350	100RB	Rear	/	21.90	22.0	0.341	<b>0.35</b>	0.650	<b>0.67</b>	-0.07
2560	21350	100RB	Left	/	21.90	22.0	0.301	<b>0.31</b>	0.572	<b>0.59</b>	0.11

**Flip cover**

Frequency		Mode	Test Position	Flip cover	Conducted Power (dBm)	Max. tune-up Power (dBm)	Measured SAR(10g) (W/kg)	Reported SAR(10g) (W/kg)	Measured SAR(1g) (W/kg)	Reported SAR(1g) (W/kg)	Power Drift (dB)
MHz	Ch.										

2560	21350	1RB_High	Front	1	22.88	23.0	0.386	<b>0.40</b>	0.731	<b>0.75</b>	-0.08
2560	21350	1RB_High	Front	2	22.88	23.0	0.403	<b>0.41</b>	0.780	<b>0.80</b>	-0.07
2560	21350	1RB_High	Front	3	22.88	23.0	0.480	<b>0.49</b>	0.934	<b>0.96</b>	-0.13

Note1: The distance between the EUT and the phantom bottom is 10mm.

Note2: The LTE mode is QPSK\_20MHz.

Note3: the detail of Flip cover is presented in section 4.4.

**Table 14.16: SAR Values (Wi-Fi 802.11b - Head)**

Ambient Temperature: 22.5 °C						Liquid Temperature: 22.0 °C					
Frequency		Side	Test Position	Figure No.	Conducted Power (dBm)	Max. tune-up Power (dBm)	Measured SAR(10g) (W/kg)	Reported SAR(10g) (W/kg)	Measured SAR(1g) (W/kg)	Reported SAR(1g) (W/kg)	Power Drift (dB)
MHz	Ch.										
2462	11	Left	Touch	/	17.21	18.5	0.259	<b>0.35</b>	0.583	<b>0.78</b>	-0.07
2437	6	Left	Touch	/	17.55	18.5	0.278	<b>0.35</b>	0.621	<b>0.77</b>	0.09
2412	1	Left	Touch	Fig.15	18.34	18.5	0.361	<b>0.37</b>	0.804	<b>0.83</b>	0.12
2412	1	Left	Tilt	/	18.34	18.5	0.269	<b>0.28</b>	0.546	<b>0.57</b>	0.15
2412	1	Right	Touch	/	18.34	18.5	0.208	<b>0.22</b>	0.399	<b>0.41</b>	0.04
2412	1	Right	Tilt	/	18.34	18.5	0.144	<b>0.15</b>	0.282	<b>0.29</b>	-0.06
Flip cover											
Frequency		Side	Test Position	Flip cover	Conducted Power (dBm)	Max. tune-up Power (dBm)	Measured SAR(10g) (W/kg)	Reported SAR(10g) (W/kg)	Measured SAR(1g) (W/kg)	Reported SAR(1g) (W/kg)	Power Drift (dB)
MHz	Ch.										
2412	1	Left	Touch	1	18.34	18.5	0.365	<b>0.38</b>	0.736	<b>0.76</b>	0.05
2412	1	Left	Touch	2	18.34	18.5	0.372	<b>0.39</b>	0.750	<b>0.78</b>	0.07
2412	1	Left	Touch	3	18.34	18.5	0.348	<b>0.36</b>	0.698	<b>0.72</b>	0.12

Note: the detail of Flip cover is presented in section 4.4.

**Table 14.17: SAR Values (Wi-Fi 802.11b - Body)**

Ambient Temperature: 22.5 °C						Liquid Temperature: 22.0 °C				
Frequency		Test Position	Figure No.	Conducted Power (dBm)	Max. tune-up Power (dBm)	Measured SAR(10g) (W/kg)	Reported SAR(10g) (W/kg)	Measured SAR(1g) (W/kg)	Reported SAR(1g) (W/kg)	Power Drift (dB)
MHz	Ch.									
2412	1	Front	/	18.34	18.5	0.068	<b>0.07</b>	0.133	<b>0.14</b>	-0.03
2412	1	Rear	Fig.16	18.34	18.5	0.099	<b>0.10</b>	0.207	<b>0.21</b>	0.07
2412	1	Right	/	18.34	18.5	0.051	<b>0.05</b>	0.100	<b>0.10</b>	0.10
2412	1	Top	/	18.34	18.5	0.040	<b>0.04</b>	0.076	<b>0.08</b>	-0.10
Flip cover										
Frequency		Test Position	Flip cover	Conducted Power (dBm)	Max. tune-up Power (dBm)	Measured SAR(10g) (W/kg)	Reported SAR(10g) (W/kg)	Measured SAR(1g) (W/kg)	Reported SAR(1g) (W/kg)	Power Drift (dB)
MHz	Ch.									
2412	1	Rear	1	18.34	18.5	0.089	<b>0.09</b>	0.183	<b>0.19</b>	0.11
2412	1	Rear	2	18.34	18.5	0.075	<b>0.08</b>	0.154	<b>0.16</b>	0.16
2412	1	Rear	3	18.34	18.5	0.062	<b>0.06</b>	0.124	<b>0.13</b>	0.17

Note1: The distance between the EUT and the phantom bottom is 10mm.

Note2: the detail of Flip cover is presented in section 4.4.

**Table 14.18: SAR Values (Wi-Fi 802.11a - Head)**

Ambient Temperature: 22.0 °C      Liquid Temperature: 21.5 °C											
Frequency		Side	Test Position	Figure No.	Conducted Power (dBm)	Max. tune-up Power (dBm)	Measured SAR(10g) (W/kg)	Reported SAR(10g) (W/kg)	Measured SAR(1g) (W/kg)	Reported SAR(1g) (W/kg)	Power Drift (dB)
MHz	Ch.										
5220	44	Left	Touch	/	12.60	13.0	0.215	<b>0.24</b>	0.927	<b>1.02</b>	0.15
5240	48	Left	Touch	/	12.39	13.0	0.207	<b>0.24</b>	0.885	<b>1.02</b>	0.07
5220	44	Left	Tilt	/	12.60	13.0	0.201	<b>0.22</b>	0.869	<b>0.95</b>	0.15
5240	48	Left	Tilt	/	12.39	13.0	0.194	<b>0.22</b>	0.837	<b>0.96</b>	0.04
5220	44	Right	Touch	/	12.60	13.0	0.133	<b>0.15</b>	0.609	<b>0.67</b>	-0.10
5220	44	Right	Tilt	/	12.60	13.0	0.172	<b>0.19</b>	0.768	<b>0.84</b>	0.15
5240	48	Right	Tilt	/	12.39	13.0	0.167	<b>0.19</b>	0.725	<b>0.83</b>	-0.09
5260	52	Left	Touch	/	12.56	13.0	0.216	<b>0.24</b>	0.948	<b>1.05</b>	0.13
5280	56	Left	Touch	/	11.88	13.0	0.188	<b>0.24</b>	0.804	<b>1.04</b>	-0.11
5260	52	Left	Tilt	Fig.17	12.56	13.0	0.233	<b>0.26</b>	0.99	<b>1.10</b>	0.19
5280	56	Left	Tilt	/	11.88	13.0	0.201	<b>0.26</b>	0.835	<b>1.08</b>	0.08
5260	52	Right	Touch	/	12.56	13.0	0.144	<b>0.16</b>	0.659	<b>0.73</b>	-0.11
5260	52	Right	Tilt	/	12.56	13.0	0.164	<b>0.18</b>	0.737	<b>0.82</b>	0.08
5280	56	Right	Tilt	/	11.88	13.0	0.135	<b>0.17</b>	0.612	<b>0.79</b>	0.07
5520	104	Left	Touch	/	12.86	13.0	0.195	<b>0.20</b>	0.875	<b>0.90</b>	0.03
5500	100	Left	Touch	/	12.69	13.0	0.179	<b>0.19</b>	0.834	<b>0.90</b>	-0.07
5520	104	Left	Tilt	/	12.86	13.0	0.219	<b>0.23</b>	0.954	<b>0.99</b>	0.13
5500	100	Left	Tilt	/	12.69	13.0	0.201	<b>0.22</b>	0.919	<b>0.99</b>	0.05
5520	104	Right	Touch	/	12.86	13.0	0.149	<b>0.15</b>	0.663	<b>0.68</b>	0.17
5520	104	Right	Tilt	/	12.86	13.0	0.204	<b>0.21</b>	0.948	<b>0.98</b>	0.13
5500	100	Right	Tilt	/	12.69	13.0	0.188	<b>0.20</b>	0.906	<b>0.97</b>	0.12
5785	157	Left	Touch	/	12.34	13.0	0.187	<b>0.22</b>	0.758	<b>0.88</b>	0.14
5805	161	Left	Touch	/	11.88	13.0	0.166	<b>0.21</b>	0.664	<b>0.86</b>	-0.08
5785	157	Left	Tilt	/	12.34	13.0	0.199	<b>0.23</b>	0.831	<b>0.97</b>	0.15
5805	161	Left	Tilt	/	11.88	13.0	0.186	<b>0.24</b>	0.723	<b>0.94</b>	-0.13
5785	157	Right	Touch	/	12.34	13.0	0.151	<b>0.18</b>	0.712	<b>0.83</b>	0.12
5805	161	Right	Touch	/	11.88	13.0	0.167	<b>0.22</b>	0.645	<b>0.83</b>	0.16
5785	157	Right	Tilt	/	12.34	13.0	0.158	<b>0.18</b>	0.766	<b>0.89</b>	0.15
5805	161	Right	Tilt	/	11.88	13.0	0.18	<b>0.23</b>	0.697	<b>0.90</b>	0.06
Flip cover											
Frequency		Side	Test Position	Flip cover	Conducted Power (dBm)	Max. tune-up Power (dBm)	Measured SAR(10g) (W/kg)	Reported SAR(10g) (W/kg)	Measured SAR(1g) (W/kg)	Reported SAR(1g) (W/kg)	Power Drift (dB)
MHz	Ch.										
5260	52	Left	Tilt	1	12.56	13.0	0.175	<b>0.19</b>	0.751	<b>0.83</b>	0.18
5260	52	Left	Tilt	2	12.56	13.0	0.178	<b>0.20</b>	0.777	<b>0.86</b>	0.05
5260	52	Left	Tilt	3	12.56	13.0	0.181	<b>0.20</b>	0.787	<b>0.87</b>	0.15

Note: the detail of Flip cover is presented in section 4.4.

**Table 14.19: SAR Values (Wi-Fi 802.11a - Body)**

Ambient Temperature: 22.0 °C					Liquid Temperature: 21.5 °C					
Frequency		Test Position	Figure No.	Conducted Power (dBm)	Max. tune-up Power (dBm)	Measured SAR(10g) (W/kg)	Reported SAR(10g) (W/kg)	Measured SAR(1g) (W/kg)	Reported SAR(1g) (W/kg)	Power Drift (dB)
MHz	Ch.									
5220	44	Front	/	12.60	13.0	0.049	<b>0.05</b>	0.135	<b>0.15</b>	0.12
5220	44	Rear	/	12.60	13.0	0.059	<b>0.06</b>	0.158	<b>0.17</b>	0.15
5220	44	Right	/	12.60	13.0	0.040	<b>0.04</b>	0.085	<b>0.09</b>	0.14
5220	44	Top	/	12.60	13.0	0.075	<b>0.08</b>	0.191	<b>0.21</b>	-0.14
5260	52	Front	/	12.56	13.0	0.043	<b>0.05</b>	0.117	<b>0.13</b>	-0.09
5260	52	Rear	/	12.56	13.0	0.054	<b>0.06</b>	0.153	<b>0.17</b>	0.19
5260	52	Right	/	12.56	13.0	0.041	<b>0.05</b>	0.085	<b>0.09</b>	0.16
5260	52	Top	Fig.18	12.56	13.0	0.096	<b>0.11</b>	0.241	<b>0.27</b>	0.16
5520	104	Front	/	12.86	13.0	0.040	<b>0.04</b>	0.108	<b>0.11</b>	0.09
5520	104	Rear	/	12.86	13.0	0.056	<b>0.06</b>	0.146	<b>0.15</b>	0.12
5520	104	Right	/	12.86	13.0	0.024	<b>0.02</b>	0.051	<b>0.05</b>	0.13
5520	104	Top	/	12.86	13.0	0.088	<b>0.09</b>	0.218	<b>0.23</b>	-0.15
5785	157	Front	/	12.34	13.0	0.027	<b>0.03</b>	0.078	<b>0.09</b>	0.08
5785	157	Rear	/	12.34	13.0	0.053	<b>0.06</b>	0.148	<b>0.17</b>	-0.17
5785	157	Right	/	12.34	13.0	0.018	<b>0.02</b>	0.039	<b>0.05</b>	0.14
5785	157	Top	/	12.34	13.0	0.077	<b>0.09</b>	0.201	<b>0.23</b>	0.02
Flip cover										
Frequency		Test Position	Flip cover	Conducted Power (dBm)	Max. tune-up Power (dBm)	Measured SAR(10g) (W/kg)	Reported SAR(10g) (W/kg)	Measured SAR(1g) (W/kg)	Reported SAR(1g) (W/kg)	Power Drift (dB)
MHz	Ch.									
5260	52	Top	1	12.56	13.0	0.090	<b>0.10</b>	0.233	<b>0.26</b>	0.13
5260	52	Top	2	12.56	13.0	0.091	<b>0.10</b>	0.236	<b>0.26</b>	0.17
5260	52	Top	3	12.56	13.0	0.091	<b>0.10</b>	0.234	<b>0.26</b>	0.12

Note1: The distance between the EUT and the phantom bottom is 10mm.

Note2: the detail of Flip cover is presented in section 4.4.

## 14.2 SAR results for Standard procedure

There is zoom scan measurement to be added for the highest measured SAR in each exposure configuration/band.

**Table 14.20: SAR Values (GSM 850 MHz Band - Head)**

Ambient Temperature: 22.3 °C      Liquid Temperature: 21.8 °C											
Flip cover											
Frequency		Side	Test Position	Flip cover	Conducted Power (dBm)	Max. tune-up Power (dBm)	Measured SAR(10g) (W/kg)	Reported SAR(10g) (W/kg)	Measured SAR(1g) (W/kg)	Reported SAR(1g) (W/kg)	Power Drift (dB)
MHz	Ch.										
848.8	251	Right	Touch	1 Fig.1	32.70	33.3	0.153	<b>0.18</b>	0.199	<b>0.23</b>	-0.15

Note: the detail of Flip cover is presented in section 4.4.

**Table 14.21: SAR Values (GSM 850 MHz Band - Body)**

Ambient Temperature: 22.3 °C      Liquid Temperature: 21.8 °C											
Frequency		Mode (number of timeslots)	Test Position	Figure No.	Conducted Power (dBm)	Max. tune-up Power (dBm)	Measured SAR(10g) (W/kg)	Reported SAR(10g) (W/kg)	Measured SAR(1g) (W/kg)	Reported SAR(1g) (W/kg)	Power Drift (dB)
MHz	Ch.										
848.8	251	GPRS (2)	Rear	Fig.2	31.10	31.3	0.220	<b>0.23</b>	0.399	<b>0.42</b>	-0.03

Note1: The distance between the EUT and the phantom bottom is 10mm.

**Table 14.22: SAR Values (GSM 1900 MHz Band - Head)**

Ambient Temperature: 22.1 °C      Liquid Temperature: 21.6 °C											
Frequency		Side	Test Position	Figure No.	Conducted Power (dBm)	Max. tune-up Power (dBm)	Measured SAR(10g) (W/kg)	Reported SAR(10g) (W/kg)	Measured SAR(1g) (W/kg)	Reported SAR(1g) (W/kg)	Power Drift (dB)
MHz	Ch.										
1909.8	810	Left	Touch	Fig.3	30.16	30.3	0.107	<b>0.11</b>	0.172	<b>0.18</b>	0.16

**Table 14.23: SAR Values (GSM 1900 MHz Band - Body)**

Ambient Temperature: 22.1 °C      Liquid Temperature: 21.6 °C											
Frequency		Mode (number of timeslots)	Test Position	Figure No.	Conducted Power (dBm)	Max. tune-up Power (dBm)	Measured SAR(10g) (W/kg)	Reported SAR(10g) (W/kg)	Measured SAR(1g) (W/kg)	Reported SAR(1g) (W/kg)	Power Drift (dB)
MHz	Ch.										
1909.8	810	GPRS (2)	Bottom	Fig.4	28.29	28.3	0.280	<b>0.28</b>	0.536	<b>0.54</b>	-0.04

Note1: The distance between the EUT and the phantom bottom is 10mm.

**Table 14.24: SAR Values (WCDMA 850 MHz Band - Head)**

Ambient Temperature: 22.3 °C      Liquid Temperature: 21.8 °C											
Flip cover											
Frequency		Side	Test Position	Flip cover	Conducted Power (dBm)	Max. tune-up Power (dBm)	Measured SAR(10g) (W/kg)	Reported SAR(10g) (W/kg)	Measured SAR(1g) (W/kg)	Reported SAR(1g) (W/kg)	Power Drift (dB)
MHz	Ch.										
846.6	4233	Right	Touch	1 Fig.5	23.50	24.0	0.146	<b>0.16</b>	0.188	<b>0.21</b>	-0.16

Note: the detail of Flip cover is presented in section 4.4.

**Table 14.25: SAR Values (WCDMA 850 MHz Band - Body)**

Frequency		Test Position	Figure No.	Conducted Power (dBm)	Max. tune-up Power (dBm)	Ambient Temperature: 22.3 °C		Liquid Temperature: 21.8 °C		Power Drift (dB)
MHz	Ch.					Measured SAR(10g) (W/kg)	Reported SAR(10g) (W/kg)	Measured SAR(1g) (W/kg)	Reported SAR(1g) (W/kg)	
826.4	4132	Rear	Fig.6	23.50	24.0	0.200	<b>0.22</b>	0.255	<b>0.29</b>	0.02

Note1: The distance between the EUT and the phantom bottom is 10mm.

**Table 14.26: SAR Values (WCDMA 1900 MHz Band - Head)**

Frequency		Side	Test Position	Figure No.	Conducted Power (dBm)	Max. tune-up Power (dBm)	Ambient Temperature: 22.1 °C		Liquid Temperature: 21.6 °C		Power Drift (dB)
MHz	Ch.						Measured SAR(10g) (W/kg)	Reported SAR(10g) (W/kg)	Measured SAR(1g) (W/kg)	Reported SAR(1g) (W/kg)	
1852.4	9262	Left	Touch	Fig.7	23.11	24.0	0.126	<b>0.15</b>	0.199	<b>0.24</b>	0.10

**Table 14.27: SAR Values (WCDMA 1900 MHz Band - Body)**

Frequency		Test Position	Figure No.	Conducted Power (dBm)	Max. tune-up Power (dBm)	Ambient Temperature: 22.1 °C		Liquid Temperature: 21.6 °C		Power Drift (dB)
MHz	Ch.					Measured SAR(10g) (W/kg)	Reported SAR(10g) (W/kg)	Measured SAR(1g) (W/kg)	Reported SAR(1g) (W/kg)	
1907.6	9538	Rear	Fig.8	23.27	24.0	0.284	<b>0.34</b>	0.513	<b>0.61</b>	0.04

Note1: The distance between the EUT and the phantom bottom is 10mm.

**Table 14.28: SAR Values (LTE Band2 - Head)**

Frequency		Mode	Side	Test Position	Figure No.	Conducted Power (dBm)	Max. tune-up Power (dBm)	Ambient Temperature: 22.1 °C		Liquid Temperature: 21.6 °C		Power Drift (dB)
MHz	Ch.							Measured SAR(10g) (W/kg)	Reported SAR(10g) (W/kg)	Measured SAR(1g) (W/kg)	Reported SAR(1g) (W/kg)	
1900	19100	1RB_Mid	Left	Touch	Fig.9	23.38	23.5	0.084	<b>0.09</b>	0.131	<b>0.13</b>	-0.13

Note1: The LTE mode is QPSK\_20MHz.

**Table 14.29: SAR Values (LTE Band2 - Body)**

Frequency		Mode	Test Position	Figure No.	Conducted Power (dBm)	Max. tune-up Power (dBm)	Ambient Temperature: 22.1 °C		Liquid Temperature: 21.6 °C		Power Drift (dB)
MHz	Ch.						Measured SAR(10g) (W/kg)	Reported SAR(10g) (W/kg)	Measured SAR(1g) (W/kg)	Reported SAR(1g) (W/kg)	
1900	19100	1RB_Mid	Rear	Fig.10	23.38	23.5	0.269	<b>0.28</b>	0.487	<b>0.50</b>	-0.11

Note1: The distance between the EUT and the phantom bottom is 10mm.

Note2: The LTE mode is QPSK\_20MHz.



**Table 14.30: SAR Values (LTE Band4 - Head)**

Ambient Temperature: 22.3 °C						Liquid Temperature: 21.8 °C						
Frequency		Mode	Side	Test Position	Figure No.	Conducted Power (dBm)	Max. tune-up Power (dBm)	Measured SAR(10g) (W/kg)	Reported SAR(10g) (W/kg)	Measured SAR(1g) (W/kg)	Reported SAR(1g) (W/kg)	Power Drift (dB)
MHz	Ch.											
1720	20050	1RB_Mid	Left	Touch	Fig.11	23.39	23.5	0.151	<b>0.15</b>	0.231	<b>0.24</b>	0.01

Note1: The LTE mode is QPSK\_20MHz.

**Table 14.31: SAR Values (LTE Band4 - Body)**

Ambient Temperature: 22.3 °C						Liquid Temperature: 21.8 °C					
Frequency		Mode	Test Position	Figure No.	Conducted Power (dBm)	Max. tune-up Power (dBm)	Measured SAR(10g) (W/kg)	Reported SAR(10g) (W/kg)	Measured SAR(1g) (W/kg)	Reported SAR(1g) (W/kg)	Power Drift (dB)
MHz	Ch.										
1720	20050	1RB_Mid	Rear	Fig.12	23.39	23.5	0.263	<b>0.27</b>	0.396	<b>0.41</b>	-0.01

Note1: The distance between the EUT and the phantom bottom is 10mm.

Note2: The LTE mode is QPSK\_20MHz.

**Table 14.32: SAR Values (LTE Band7 - Head)**

Ambient Temperature: 22.2 °C						Liquid Temperature: 21.7 °C						
Frequency		Mode	Side	Test Position	Figure No.	Conducted Power (dBm)	Max. tune-up Power (dBm)	Measured SAR(10g) (W/kg)	Reported SAR(10g) (W/kg)	Measured SAR(1g) (W/kg)	Reported SAR(1g) (W/kg)	Power Drift (dB)
MHz	Ch.											
2560	21350	1RB_High	Left	Touch	Fig.13	22.88	23.0	0.23	<b>0.23</b>	0.418	<b>0.43</b>	0.18

Note1: The LTE mode is QPSK\_20MHz.

**Table 14.33: SAR Values (LTE Band7 - Body)**

Ambient Temperature: 22.2 °C						Liquid Temperature: 21.7 °C					
Frequency		Mode	Test Position	Figure No.	Conducted Power (dBm)	Max. tune-up Power (dBm)	Measured SAR(10g) (W/kg)	Reported SAR(10g) (W/kg)	Measured SAR(1g) (W/kg)	Reported SAR(1g) (W/kg)	Power Drift (dB)
MHz	Ch.										
2560	21350	1RB_High	Front	Fig.14	22.88	23.0	0.507	<b>0.52</b>	0.958	<b>0.98</b>	-0.11

Note1: The distance between the EUT and the phantom bottom is 10mm.

Note2: The LTE mode is QPSK\_20MHz.

**Table 14.34: SAR Values (Wi-Fi 802.11b - Head)**

Ambient Temperature: 22.5 °C						Liquid Temperature: 22.0 °C					
Frequency		Side	Test Position	Figure No.	Conducted Power (dBm)	Max. tune-up Power (dBm)	Measured SAR(10g) (W/kg)	Reported SAR(10g) (W/kg)	Measured SAR(1g) (W/kg)	Reported SAR(1g) (W/kg)	Power Drift (dB)
MHz	Ch.										
2412	1	Left	Touch	Fig.15	18.34	18.5	0.361	<b>0.37</b>	0.804	<b>0.83</b>	0.12

**Table 14.35: SAR Values (Wi-Fi 802.11b - Body)**

Frequency		Test Position	Figure No.	Conducted Power (dBm)	Max. tune-up Power (dBm)	Ambient Temperature: 22.5 °C		Liquid Temperature: 22.0 °C		Power Drift (dB)
MHz	Ch.					Measured SAR(10g) (W/kg)	Reported SAR(10g) (W/kg)	Measured SAR(1g) (W/kg)	Reported SAR(1g) (W/kg)	
2412	1	Rear	Fig.16	18.34	18.5	0.099	<b>0.10</b>	0.207	<b>0.21</b>	0.07

Note1: The distance between the EUT and the phantom bottom is 10mm.

**Table 14.36: SAR Values (Wi-Fi 802.11a - Head)**

Frequency		Side	Test Position	Figure No.	Conducted Power (dBm)	Max. tune-up Power (dBm)	Ambient Temperature: 22.0 °C		Liquid Temperature: 21.5 °C		Power Drift (dB)
MHz	Ch.						Measured SAR(10g) (W/kg)	Reported SAR(10g) (W/kg)	Measured SAR(1g) (W/kg)	Reported SAR(1g) (W/kg)	
5220	44	Left	Touch	/	12.60	13.0	0.215	<b>0.24</b>	0.927	<b>1.02</b>	0.15
5240	48	Left	Touch	/	12.39	13.0	0.207	<b>0.24</b>	0.885	<b>1.02</b>	0.07
5220	44	Left	Tilt	/	12.60	13.0	0.201	<b>0.22</b>	0.869	<b>0.95</b>	0.15
5240	48	Left	Tilt	/	12.39	13.0	0.194	<b>0.22</b>	0.837	<b>0.96</b>	0.04
5220	44	Right	Touch	/	12.60	13.0	0.133	<b>0.15</b>	0.609	<b>0.67</b>	-0.10
5220	44	Right	Tilt	/	12.60	13.0	0.172	<b>0.19</b>	0.768	<b>0.84</b>	0.15
5240	48	Right	Tilt	/	12.39	13.0	0.167	<b>0.19</b>	0.725	<b>0.83</b>	-0.09
5260	52	Left	Touch	/	12.56	13.0	0.216	<b>0.24</b>	0.948	<b>1.05</b>	0.13
5280	56	Left	Touch	/	11.88	13.0	0.188	<b>0.24</b>	0.804	<b>1.04</b>	-0.11
5260	52	Left	Tilt	Fig.17	12.56	13.0	0.233	<b>0.26</b>	0.99	<b>1.10</b>	0.19
5280	56	Left	Tilt	/	11.88	13.0	0.201	<b>0.26</b>	0.835	<b>1.08</b>	0.08
5260	52	Right	Touch	/	12.56	13.0	0.144	<b>0.16</b>	0.659	<b>0.73</b>	-0.11
5260	52	Right	Tilt	/	12.56	13.0	0.164	<b>0.18</b>	0.737	<b>0.82</b>	0.08
5280	56	Right	Tilt	/	11.88	13.0	0.135	<b>0.17</b>	0.612	<b>0.79</b>	0.07
5520	104	Left	Touch	/	12.86	13.0	0.195	<b>0.20</b>	0.875	<b>0.90</b>	0.03
5500	100	Left	Touch	/	12.69	13.0	0.179	<b>0.19</b>	0.834	<b>0.90</b>	-0.07
5520	104	Left	Tilt	/	12.86	13.0	0.219	<b>0.23</b>	0.954	<b>0.99</b>	0.13
5500	100	Left	Tilt	/	12.69	13.0	0.201	<b>0.22</b>	0.919	<b>0.99</b>	0.05
5520	104	Right	Touch	/	12.86	13.0	0.149	<b>0.15</b>	0.663	<b>0.68</b>	0.17
5520	104	Right	Tilt	/	12.86	13.0	0.204	<b>0.21</b>	0.948	<b>0.98</b>	0.13
5500	100	Right	Tilt	/	12.69	13.0	0.188	<b>0.20</b>	0.906	<b>0.97</b>	0.12
5785	157	Left	Touch	/	12.34	13.0	0.187	<b>0.22</b>	0.758	<b>0.88</b>	0.14
5805	161	Left	Touch	/	11.88	13.0	0.166	<b>0.21</b>	0.664	<b>0.86</b>	-0.08
5785	157	Left	Tilt	/	12.34	13.0	0.199	<b>0.23</b>	0.831	<b>0.97</b>	0.15
5805	161	Left	Tilt	/	11.88	13.0	0.186	<b>0.24</b>	0.723	<b>0.94</b>	-0.13
5785	157	Right	Touch	/	12.34	13.0	0.151	<b>0.18</b>	0.712	<b>0.83</b>	0.12
5805	161	Right	Touch	/	11.88	13.0	0.167	<b>0.22</b>	0.645	<b>0.83</b>	0.16
5785	157	Right	Tilt	/	12.34	13.0	0.158	<b>0.18</b>	0.766	<b>0.89</b>	0.15
5805	161	Right	Tilt	/	11.88	13.0	0.18	<b>0.23</b>	0.697	<b>0.90</b>	0.06

Flip cover											
Frequency		Side	Test Position	Flip cover	Conducted Power (dBm)	Max. tune-up Power (dBm)	Measured SAR(10g) (W/kg)	Reported SAR(10g) (W/kg)	Measured SAR(1g) (W/kg)	Reported SAR(1g) (W/kg)	Power Drift (dB)
MHz	Ch.										
5260	52	Left	Tilt	1	12.56	13.0	0.175	<b>0.19</b>	0.751	<b>0.83</b>	0.18
5260	52	Left	Tilt	2	12.56	13.0	0.178	<b>0.20</b>	0.777	<b>0.86</b>	0.05
5260	52	Left	Tilt	3	12.56	13.0	0.181	<b>0.20</b>	0.787	<b>0.87</b>	0.15

Note: the detail of Flip cover is presented in section 4.4.

**Table 14.37: SAR Values (Wi-Fi 802.11a - Body)**

Ambient Temperature: 22.0 °C											Liquid Temperature: 21.5 °C										
Frequency		Test Position	Figure No.	Conducted Power (dBm)	Max. tune-up Power (dBm)	Measured SAR(10g) (W/kg)	Reported SAR(10g) (W/kg)	Measured SAR(1g) (W/kg)	Reported SAR(1g) (W/kg)	Power Drift (dB)											
MHz	Ch.																				
5220	44	Front	/	12.60	13.0	0.049	<b>0.05</b>	0.135	<b>0.15</b>	0.12											
5220	44	Rear	/	12.60	13.0	0.059	<b>0.06</b>	0.158	<b>0.17</b>	0.15											
5220	44	Right	/	12.60	13.0	0.040	<b>0.04</b>	0.085	<b>0.09</b>	0.14											
5220	44	Top	/	12.60	13.0	0.075	<b>0.08</b>	0.191	<b>0.21</b>	-0.14											
5260	52	Front	/	12.56	13.0	0.043	<b>0.05</b>	0.117	<b>0.13</b>	-0.09											
5260	52	Rear	/	12.56	13.0	0.054	<b>0.06</b>	0.153	<b>0.17</b>	0.19											
5260	52	Right	/	12.56	13.0	0.041	<b>0.05</b>	0.085	<b>0.09</b>	0.16											
5260	52	Top	Fig.18	12.56	13.0	0.096	<b>0.11</b>	0.241	<b>0.27</b>	0.16											
5520	104	Front	/	12.86	13.0	0.040	<b>0.04</b>	0.108	<b>0.11</b>	0.09											
5520	104	Rear	/	12.86	13.0	0.056	<b>0.06</b>	0.146	<b>0.15</b>	0.12											
5520	104	Right	/	12.86	13.0	0.024	<b>0.02</b>	0.051	<b>0.05</b>	0.13											
5520	104	Top	/	12.86	13.0	0.088	<b>0.09</b>	0.218	<b>0.23</b>	-0.15											
5785	157	Front	/	12.34	13.0	0.027	<b>0.03</b>	0.078	<b>0.09</b>	0.08											
5785	157	Rear	/	12.34	13.0	0.053	<b>0.06</b>	0.148	<b>0.17</b>	-0.17											
5785	157	Right	/	12.34	13.0	0.018	<b>0.02</b>	0.039	<b>0.05</b>	0.14											
5785	157	Top	/	12.34	13.0	0.077	<b>0.09</b>	0.201	<b>0.23</b>	0.02											
Flip cover																					
Frequency		Test Position	Flip cover	Conducted Power (dBm)	Max. tune-up Power (dBm)	Measured SAR(10g) (W/kg)	Reported SAR(10g) (W/kg)	Measured SAR(1g) (W/kg)	Reported SAR(1g) (W/kg)	Power Drift (dB)											
MHz	Ch.																				
5260	52	Top	1	12.56	13.0	0.090	<b>0.10</b>	0.233	<b>0.26</b>	0.13											
5260	52	Top	2	12.56	13.0	0.091	<b>0.10</b>	0.236	<b>0.26</b>	0.17											
5260	52	Top	3	12.56	13.0	0.091	<b>0.10</b>	0.234	<b>0.26</b>	0.12											

Note1: The distance between the EUT and the phantom bottom is 10mm.

Note2: the detail of Flip cover is presented in section 4.4.

## 15 SAR Measurement Variability

SAR measurement variability must be assessed for each frequency band, which is determined by the SAR probe calibration point and tissue-equivalent medium used for the device measurements. When both head and body tissue-equivalent media are required for SAR measurements in a frequency band, the variability measurement procedures should be applied to the tissue medium with the highest measured SAR, using the highest measured SAR configuration for that tissue-equivalent medium.

The following procedures are applied to determine if repeated measurements are required.

- 1) Repeated measurement is not required when the original highest measured SAR is  $< 0.80$  W/kg; steps 2) through 4) do not apply.
- 2) When the original highest measured SAR is  $\geq 0.80$  W/kg, repeat that measurement once.
- 3) Perform a second repeated measurement only if the ratio of largest to smallest SAR for the original and first repeated measurements is  $> 1.20$  or when the original or repeated measurement is  $\geq 1.45$  W/kg (~ 10% from the 1-g SAR limit).
- 4) Perform a third repeated measurement only if the original, first or second repeated measurement is  $\geq 1.5$  W/kg and the ratio of largest to smallest SAR for the original, first and second repeated measurements is  $> 1.20$ .

**Table 15.1: SAR Measurement Variability for Body LTE Band 7 (1g)**

Frequency		Test Position	Spacing (mm)	Original SAR (W/kg)	First Repeated SAR (W/kg)	The Ratio	Second Repeated SAR (W/kg)
MHz	Ch.						
2560	21350	Front	10	0.958	0.952	1.01	/

**Table 15.2: SAR Measurement Variability for Head Wi-Fi 802.11b (1g)**

Frequency		Side	Test Position	Original SAR (W/kg)	First Repeated SAR (W/kg)	The Ratio	Second Repeated SAR (W/kg)
MHz	Ch.						
2412	1	Left	Touch	0.804	0.797	1.01	/

**Table 15.3: SAR Measurement Variability for Head Wi-Fi 802.11a (1g)**

Frequency		Side	Test Position	Original SAR (W/kg)	First Repeated SAR (W/kg)	The Ratio	Second Repeated SAR (W/kg)
MHz	Ch.						
5260	52	Left	Tilt	0.990	0.984	1.01	/

## 16 Measurement Uncertainty

### 16.1 Measurement Uncertainty for Normal SAR Tests (300MHz~3GHz)

No.	Error Description	Type	Uncertainty value	Probably Distribution	Div.	(Ci) 1g	(Ci) 10g	Std. Unc. (1g)	Std. Unc. (10g)	Degree of freedom
<b>Measurement system</b>										
1	Probe calibration	B	5.5	N	1	1	1	5.5	5.5	∞
2	Isotropy	B	4.7	R	$\sqrt{3}$	0.7	0.7	1.9	1.9	∞
3	Boundary effect	B	1.0	R	$\sqrt{3}$	1	1	0.6	0.6	∞
4	Linearity	B	4.7	R	$\sqrt{3}$	1	1	2.7	2.7	∞
5	Detection limit	B	1.0	R	$\sqrt{3}$	1	1	0.6	0.6	∞
6	Readout electronics	B	0.3	R	$\sqrt{3}$	1	1	0.3	0.3	∞
7	Response time	B	0.8	R	$\sqrt{3}$	1	1	0.5	0.5	∞
8	Integration time	B	2.6	R	$\sqrt{3}$	1	1	1.5	1.5	∞
9	RF ambient conditions-noise	B	0	R	$\sqrt{3}$	1	1	0	0	∞
10	RF ambient conditions-reflection	B	0	R	$\sqrt{3}$	1	1	0	0	∞
11	Probe positioned mech. restrictions	B	0.4	R	$\sqrt{3}$	1	1	0.2	0.2	∞
12	Probe positioning with respect to phantom shell	B	2.9	R	$\sqrt{3}$	1	1	1.7	1.7	∞
13	Post-processing	B	1.0	R	$\sqrt{3}$	1	1	0.6	0.6	∞
<b>Test sample related</b>										
14	Test sample positioning	A	3.3	N	1	1	1	3.3	3.3	71
15	Device holder uncertainty	A	3.4	N	1	1	1	3.4	3.4	5
16	Drift of output power	B	5.0	R	$\sqrt{3}$	1	1	2.9	2.9	∞
<b>Phantom and set-up</b>										
17	Phantom uncertainty	B	4.0	R	$\sqrt{3}$	1	1	2.3	2.3	∞
18	Liquid conductivity (target)	B	5.0	R	$\sqrt{3}$	0.64	0.43	1.8	1.2	∞
19	Liquid conductivity (meas.)	A	2.06	N	1	0.64	0.43	1.32	0.89	43
20	Liquid permittivity (target)	B	5.0	R	$\sqrt{3}$	0.6	0.49	1.7	1.4	∞
21	Liquid permittivity (meas.)	A	1.6	N	1	0.6	0.49	1.0	0.8	521

Combined standard uncertainty	$u_c = \sqrt{\sum_{i=1}^{21} c_i^2 u_i^2}$					9.25	9.12	257
Expanded uncertainty (confidence interval of 95 %)	$u_e = 2u_c$					18.5	18.2	

### 16.2 Measurement Uncertainty for Normal SAR Tests (3~6GHz)

No.	Error Description	Type	Uncertainty value	Probably Distribution	Div.	(Ci) 1g	(Ci) 10g	Std. Unc. (1g)	Std. Unc. (10g)	Degree of freedom
<b>Measurement system</b>										
1	Probe calibration	B	6.5	N	1	1	1	6.5	6.5	∞
2	Isotropy	B	4.7	R	$\sqrt{3}$	0.7	0.7	1.9	1.9	∞
3	Boundary effect	B	2.0	R	$\sqrt{3}$	1	1	1.2	1.2	∞
4	Linearity	B	4.7	R	$\sqrt{3}$	1	1	2.7	2.7	∞
5	Detection limit	B	1.0	R	$\sqrt{3}$	1	1	0.6	0.6	∞
6	Readout electronics	B	0.3	R	$\sqrt{3}$	1	1	0.3	0.3	∞
7	Response time	B	0.8	R	$\sqrt{3}$	1	1	0.5	0.5	∞
8	Integration time	B	2.6	R	$\sqrt{3}$	1	1	1.5	1.5	∞
9	RF ambient conditions-noise	B	0	R	$\sqrt{3}$	1	1	0	0	∞
10	RF ambient conditions-reflection	B	0	R	$\sqrt{3}$	1	1	0	0	∞
11	Probe positioned mech. restrictions	B	0.8	R	$\sqrt{3}$	1	1	0.5	0.5	∞
12	Probe positioning with respect to phantom shell	B	6.7	R	$\sqrt{3}$	1	1	3.9	3.9	∞
13	Post-processing	B	4.0	R	$\sqrt{3}$	1	1	2.3	2.3	∞
<b>Test sample related</b>										
14	Test sample positioning	A	3.3	N	1	1	1	3.3	3.3	71
15	Device holder uncertainty	A	3.4	N	1	1	1	3.4	3.4	5
16	Drift of output power	B	5.0	R	$\sqrt{3}$	1	1	2.9	2.9	∞
<b>Phantom and set-up</b>										
17	Phantom uncertainty	B	4.0	R	$\sqrt{3}$	1	1	2.3	2.3	∞
18	Liquid conductivity (target)	B	5.0	R	$\sqrt{3}$	0.64	0.43	1.8	1.2	∞
19	Liquid conductivity (meas.)	A	2.06	N	1	0.64	0.43	1.32	0.89	43

20	Liquid permittivity (target)	B	5.0	R	$\sqrt{3}$	0.6	0.49	1.7	1.4	$\infty$
21	Liquid permittivity (meas.)	A	1.6	N	1	0.6	0.49	1.0	0.8	521
Combined standard uncertainty		$u_c = \sqrt{\sum_{i=1}^{21} c_i^2 u_i^2}$						10.8	10.7	257
Expanded uncertainty (confidence interval of 95 %)		$u_e = 2u_c$						21.6	21.4	

### 16.3 Measurement Uncertainty for Fast SAR Tests (300MHz~3GHz)

No.	Error Description	Type	Uncertainty value	Probably Distribution	Div.	(Ci) 1g	(Ci) 10g	Std. Unc. (1g)	Std. Unc. (10g)	Degree of freedom
<b>Measurement system</b>										
1	Probe calibration	B	5.5	N	1	1	1	5.5	5.5	$\infty$
2	Isotropy	B	4.7	R	$\sqrt{3}$	0.7	0.7	1.9	1.9	$\infty$
3	Boundary effect	B	1.0	R	$\sqrt{3}$	1	1	0.6	0.6	$\infty$
4	Linearity	B	4.7	R	$\sqrt{3}$	1	1	2.7	2.7	$\infty$
5	Detection limit	B	1.0	R	$\sqrt{3}$	1	1	0.6	0.6	$\infty$
6	Readout electronics	B	0.3	R	$\sqrt{3}$	1	1	0.3	0.3	$\infty$
7	Response time	B	0.8	R	$\sqrt{3}$	1	1	0.5	0.5	$\infty$
8	Integration time	B	2.6	R	$\sqrt{3}$	1	1	1.5	1.5	$\infty$
9	RF ambient conditions-noise	B	0	R	$\sqrt{3}$	1	1	0	0	$\infty$
10	RF ambient conditions-reflection	B	0	R	$\sqrt{3}$	1	1	0	0	$\infty$
11	Probe positioned mech. Restrictions	B	0.4	R	$\sqrt{3}$	1	1	0.2	0.2	$\infty$
12	Probe positioning with respect to phantom shell	B	2.9	R	$\sqrt{3}$	1	1	1.7	1.7	$\infty$
13	Post-processing	B	1.0	R	$\sqrt{3}$	1	1	0.6	0.6	$\infty$
14	Fast SAR z-Approximation	B	7.0	R	$\sqrt{3}$	1	1	4.0	4.0	$\infty$
<b>Test sample related</b>										
15	Test sample positioning	A	3.3	N	1	1	1	3.3	3.3	71
16	Device holder uncertainty	A	3.4	N	1	1	1	3.4	3.4	5
17	Drift of output power	B	5.0	R	$\sqrt{3}$	1	1	2.9	2.9	$\infty$