

FCC RF Test Report

APPLICANT : TCT Mobile Limited
EQUIPMENT : UMTS Quad band / GSM Quad band mobile phone
BRAND NAME : ALCATEL
MODEL NAME : Flame
FCC ID : RAD481
STANDARD : FCC Part 15 Subpart C §15.247
CLASSIFICATION : (DTS) Digital Transmission System

The product was received on Mar. 26, 2014 and testing was completed on Apr. 25, 2014. We, SPORTON INTERNATIONAL (KUNSHAN) INC., would like to declare that the tested sample has been evaluated in accordance with the procedures and shown to be compliant with the applicable technical standards.

The test results in this report apply exclusively to the tested model / sample. Without written approval of SPORTON INTERNATIONAL (KUNSHAN) INC., the test report shall not be reproduced except in full.



Reviewed by: Joseph Lin / Supervisor



Approved by: Jones Tsai / Manager



Testing Laboratory
2627

SPORTON INTERNATIONAL (KUNSHAN) INC.
No. 3-2, PingXiang Road, Kunshan, Jiangsu Province, P.R.C.



TABLE OF CONTENTS

REVISION HISTORY..... 3

SUMMARY OF TEST RESULT 4

1 GENERAL DESCRIPTION 5

 1.1 Applicant 5

 1.2 Manufacturer 5

 1.3 Feature of Equipment Under Test 5

 1.4 Product Specification of Equipment Under Test 5

 1.5 Modification of EUT 6

 1.6 Testing Site 6

 1.7 Applicable Standards 6

2 TEST CONFIGURATION OF EQUIPMENT UNDER TEST 7

 2.1 Carrier Frequency Channel 7

 2.2 Pre-Scanned RF Power 8

 2.3 Test Mode 9

 2.4 Connection Diagram of Test System 10

 2.5 Support Unit used in test configuration and system 11

 2.6 EUT Operation Test Setup 11

 2.7 Measurement Results Explanation Example 11

3 TEST RESULT 12

 3.1 6dB Bandwidth Measurement 12

 3.2 Output Power Measurement 14

 3.3 Power Spectral Density Measurement 17

 3.4 Conducted Band Edges and Spurious Emission Measurement 19

 3.5 Radiated Band Edges and Spurious Emission Measurement 29

 3.6 AC Conducted Emission Measurement 46

 3.7 Antenna Requirements 50

4 LIST OF MEASURING EQUIPMENT 51

5 UNCERTAINTY OF EVALUATION 52

APPENDIX A. SETUP PHOTOGRAPHS



REVISION HISTORY

REPORT NO.	VERSION	DESCRIPTION	ISSUED DATE
FR432602C	Rev. 01	Initial issue of report	May 22, 2014

SUMMARY OF TEST RESULT

Report Section	FCC Rule	Description	Limit	Result	Remark
3.1	15.247(a)(2)	6dB Bandwidth	$\geq 0.5\text{MHz}$	Pass	-
3.2	15.247(b)	Power Output Measurement	$\leq 30\text{dBm}$	Pass	-
3.3	15.247(e)	Power Spectral Density	$\leq 8\text{dBm}/3\text{kHz}$	Pass	-
3.4	15.247(d)	Conducted Band Edges	$\leq 20\text{dBc}$	Pass	-
		Conducted Spurious Emission		Pass	-
3.5	15.247(d)	Radiated Band Edges and Radiated Spurious Emission	15.209(a) & 15.247(d)	Pass	Under limit 5.91 dB at 2483.650 MHz
3.6	15.207	AC Conducted Emission	15.207(a)	Pass	Under limit 9.81 dB at 1.790 MHz
3.7	15.203 & 15.247(b)	Antenna Requirement	N/A	Pass	-

1 General Description

1.1 Applicant

TCT Mobile Limited

5F, C building, No. 232, Liang Jing Road ZhangJiang High-Tech Park, Pudong Area Shanghai, P.R. China. 201203

1.2 Manufacturer

TCT Mobile Limited

5F, C building, No. 232, Liang Jing Road ZhangJiang High-Tech Park, Pudong Area Shanghai, P.R. China. 201203

1.3 Feature of Equipment Under Test

Product Feature	
Equipment	UMTS Quad band / GSM Quad band mobile phone
Brand Name	ALCATEL
Model Name	Flame
FCC ID	RAD481
EUT supports Radios application	GSM/GPRS/EGPRS(Downlink Only)/ WCDMA/HSPA/HSPA+(Downlink Only)/NFC/ WLAN 2.4GHz 802.11b/g/n HT20/ Bluetooth v3.0 + EDR/Bluetooth v4.0 LE
HW Version	PIO
SW Version	V10E
EUT Stage	Identical Prototype

Remark: The above EUT's information was declared by manufacturer. Please refer to the specifications or user's manual for more detailed description.

1.4 Product Specification of Equipment Under Test

Product Specification subjective to this standard	
Tx/Rx Channel Frequency Range	2412 MHz ~ 2462 MHz
Maximum (Peak) Output Power to Antenna	802.11b : 16.02 dBm (0.0400 W) 802.11g : 18.77 dBm (0.0753 W) 802.11n HT20 : 17.19 dBm (0.0524 W)
Antenna Type	PIFA Antenna with gain -1.10 dBi
Type of Modulation	802.11b : DSSS (DBPSK / DQPSK / CCK) 802.11g/n : OFDM (BPSK / QPSK / 16QAM / 64QAM)

1.5 Modification of EUT

No modifications are made to the EUT during all test items.

1.6 Testing Site

Test Site	SPORTON INTERNATIONAL (KUNSHAN) INC.			
Test Site Location	No. 3-2, PingXiang Road, Kunshan, Jiangsu Province, P.R.C. TEL: +86-0512-5790-0158 FAX: +86-0512-5790-0958			
Test Site No.	Sporton Site No.			FCC Registration No.
	TH01-KS	03CH01-KS	CO01-KS	149928

Note: The test site complies with ANSI C63.4 2003 requirement.

1.7 Applicable Standards

According to the specifications of the manufacturer, the EUT must comply with the requirements of the following standards:

- ♦ FCC Part 15 Subpart C §15.247
- ♦ FCC KDB Publication No. 558074 D01 DTS Meas. Guidance v03r01
- ♦ ANSI C63.4-2003

Remark:

1. All test items were verified and recorded according to the standards and without any deviation during the test.
2. This EUT has also been tested and complied with the requirements of FCC Part 15, Subpart B, recorded in a separate test report.



2 Test Configuration of Equipment Under Test

The EUT has been associated with peripherals and configuration operated in a manner tended to maximize its emission characteristics in a typical application. Frequency range investigated: conducted emission (150 kHz to 30 MHz) and radiated emission (9 kHz to the 10th harmonic of the highest fundamental frequency or to 40 GHz, whichever is lower). For radiated measurement, pre-scanned in three orthogonal panels, X, Y, Z. The worst cases (Y plane) were recorded in this report.

The final configuration from all the combinations and the worst-case data rates were investigated by measuring the maximum power across all the data rates and modulation modes under section 2.2.

Based on the worst configuration found above, the RF power setting is set individually to meet FCC compliance limit for the final conducted and radiated tests shown in section 2.3.

2.1 Carrier Frequency Channel

Frequency Band	Channel	Freq. (MHz)	Channel	Freq. (MHz)
2400-2483.5 MHz	1	2412	7	2442
	2	2417	8	2447
	3	2422	9	2452
	4	2427	10	2457
	5	2432	11	2462
	6	2437	-	-



2.2 Pre-Scanned RF Power

Preliminary tests were performed in different data rate and data rate associated with the highest power were chosen for full test shown in the following tables.

2.4GHz 802.11b RF Power (dBm)						
Power vs. Channel			Power vs. Data Rate			
Channel	Frequency (MHz)	Data Rate	Channel	2Mbps	5.5Mbps	11Mbps
		1Mbps				
CH 01	2412	14.43	CH 11	15.87	15.91	16.01
CH 06	2437	15.13				
CH 11	2462	16.02				

2.4GHz 802.11g RF Power (dBm)										
Power vs. Channel			Power vs. Data Rate							
Channel	Frequency (MHz)	Data Rate	Channel	9Mbps	12Mbps	18Mbps	24Mbps	36Mbps	48Mbps	54Mbps
		6Mbps								
CH 01	2412	16.97	CH 11	18.51	18.65	18.45	18.51	18.61	18.66	18.67
CH 06	2437	17.57								
CH 11	2462	18.77								

2.4GHz 802.11n HT20 RF Power (dBm)										
Power vs. Channel			Power vs. MCS Index							
Channel	Frequency (MHz)	MCS Index	Channel	MCS1	MCS2	MCS3	MCS4	MCS5	MCS6	MCS7
		MCS0								
CH 01	2412	15.82	CH 11	16.87	17.11	17.12	17.04	17.09	17.13	17.16
CH 06	2437	16.12								
CH 11	2462	17.19								

2.3 Test Mode

Final results of test modes, data rates and test channels are shown as following table.

Test Cases				
	Test Items	Mode	Data Rate	Test Channel
Conducted TCs	6dB BW Power Spectral Density	802.11b	1 Mbps	1/6/11
		802.11g	6 Mbps	1/6/11
		802.11n HT20	MCS0	1/6/11
	Output Power	802.11b	1 Mbps	1/6/11
		802.11g	6 Mbps	1/6/11
		802.11n HT20	MCS0	1/6/11
	Conducted Band Edge	802.11b	1 Mbps	1/11
		802.11g	6 Mbps	1/11
		802.11n HT20	MCS0	1/11
	Conducted Spurious Emission	802.11b	1 Mbps	1/6/11
		802.11g	6 Mbps	1/6/11
		802.11n HT20	MCS0	1/6/11
Radiated TCs	Radiated Band Edge	802.11b	1 Mbps	1/11
		802.11g	6 Mbps	1/11
		802.11n HT20	MCS0	1/11
	Radiated Spurious Emission	802.11b	1 Mbps	1/6/11
		802.11g	6 Mbps	1/6/11
		802.11n HT20	MCS0	1/6/11
AC Conducted Emission	Mode 1 : GSM850 Idle + Bluetooth Link + WLAN Link + USB Cable (Charging from Adapter) + Earphone + NFC Tx			

2.4 Connection Diagram of Test System

<WLAN Tx Mode>

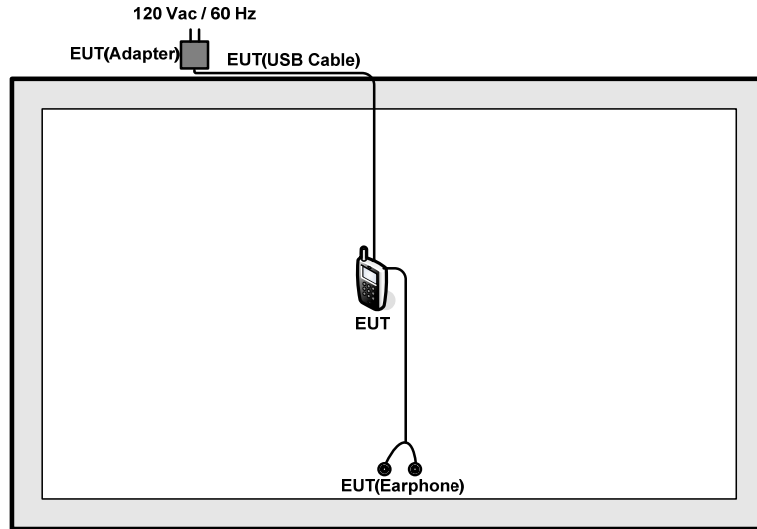

<AC Conducted Emission Mode>

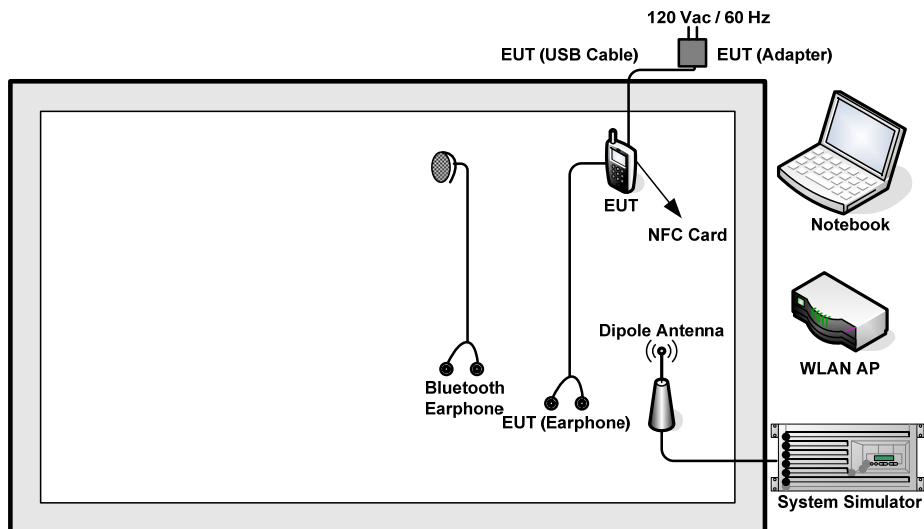

2.5 Support Unit used in test configuration and system

Item	Equipment	Trade Name	Model Name	FCC ID	Data Cable	Power Cord
1.	System Simulator	R&S	CMU 200	N/A	N/A	Unshielded, 1.8 m
2.	WLAN AP	D-Link	DIR-855	KA2DIR855A2	N/A	Unshielded, 1.8 m
3.	Notebook	Lenovo	G480	PRC4	N/A	AC I/P: Unshielded, 1.8 m DC O/P: Shielded, 1.8 m
4.	Bluetooth Earphone	Nokia	BH-106	QTLBH-106	N/A	N/A
5.	NFC Card	N/A	N/A	N/A	N/A	N/A

2.6 EUT Operation Test Setup

For WLAN function, the engineering test program was provided and enabled to make EUT continuous transmit/receive.

For AC power line conducted emissions, the EUT was set to connect with the WLAN AP under large package sizes transmission.

2.7 Measurement Results Explanation Example

For all conducted test items:

The offset level is set in the spectrum analyzer to compensate the RF cable loss between EUT conducted output port and spectrum analyzer. With the offset compensation, the spectrum analyzer reading level is exactly the EUT RF output level.

Example:

The spectrum analyzer offset is derived from RF cable loss.

Offset = RF cable loss.

Following shows an offset computation example with cable loss 6 dB.

Offset (dB) = RF cable loss (dB) = 6 (dB)

3 Test Result

3.1 6dB Bandwidth Measurement

3.1.1 Limit of 6dB Bandwidth

The minimum 6 dB bandwidth shall be at least 500 kHz.

3.1.2 Measuring Instruments

The measuring equipment is listed in the section 4 of this test report.

3.1.3 Test Procedures

1. The testing follows FCC KDB Publication No. 558074 DTS D01 Meas. Guidance v03r01.
2. The RF output of EUT was connected to the spectrum analyzer by RF cable and attenuator. The path loss was compensated to the results for each measurement.
3. Set to the maximum power setting and enable the EUT transmit continuously.
4. Make the measurement with the spectrum analyzer's resolution bandwidth (RBW) = 100 kHz. Set the Video bandwidth (VBW) = 300 kHz. In order to make an accurate measurement. The 6 dB bandwidth must be greater than 500 kHz.
5. Measure and record the results in the test report.

3.1.4 Test Setup

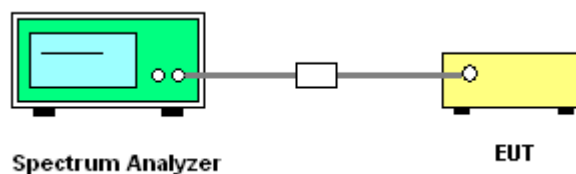

3.1.5 Test Result of 6dB Bandwidth

Test Band :	2.4GHz	Temperature :	23~24°C
Test Engineer :	Adonis Li	Relative Humidity :	47~48%

Mod.	Data Rate	N _{TX}	Channel	Freq. (MHz)	6dB Bandwidth (MHz)	6dB Bandwidth Min. Limit (MHz)	Pass/Fail
11b	1Mbps	1	1	2412	7.08	0.5	Pass
11b	1Mbps	1	6	2437	7.08	0.5	Pass
11b	1Mbps	1	11	2462	7.04	0.5	Pass
11g	6Mbps	1	1	2412	16.44	0.5	Pass
11g	6Mbps	1	6	2437	16.48	0.5	Pass
11g	6Mbps	1	11	2462	16.48	0.5	Pass
HT20	MCS0	1	1	2412	17.74	0.5	Pass
HT20	MCS0	1	6	2437	17.74	0.5	Pass
HT20	MCS0	1	11	2462	17.64	0.5	Pass

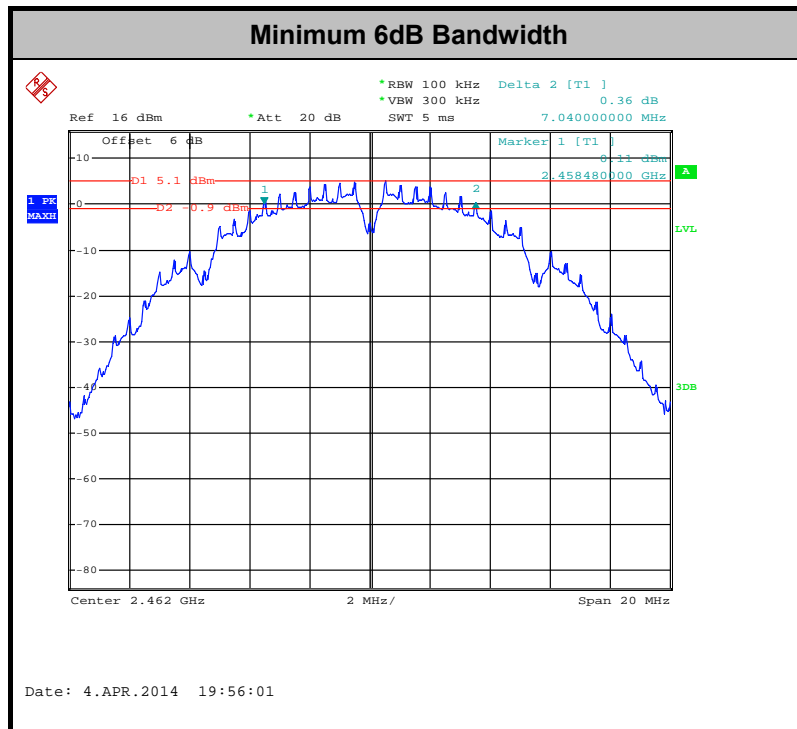

Note: The occupied channel bandwidth is maintained within the band of operation for all of the modulations.

3.2 Output Power Measurement

3.2.1 Limit of Output Power

For systems using digital modulation in the 2400-2483.5MHz, the limit for peak output power is 30dBm. If transmitting Antenna of directional gain greater than 6dBi are used the peak output power from the intentional radiator shall be reduced below the above stated value by the amount in dB that the directional gain of the Antenna exceeds 6 dBi. In case of point-to-point operation, the limit has to be reduced by 1dB for every 3dB that the directional gain of the Antenna exceeds 6dBi.

3.2.2 Measuring Instruments

The measuring equipment is listed in the section 4 of this test report.

3.2.3 Test Procedures

1. The testing follows the Measurement Procedure of FCC KDB No. 558074 DTS D01 Meas. Guidance v03r01.
2. The RF output of EUT was connected to the power meter by RF cable and attenuator. The path loss was compensated to the results for each measurement.
3. Set to the maximum power setting and enable the EUT transmit continuously.
4. Measure the conducted output power and record the results in the test report.

3.2.4 Test Setup

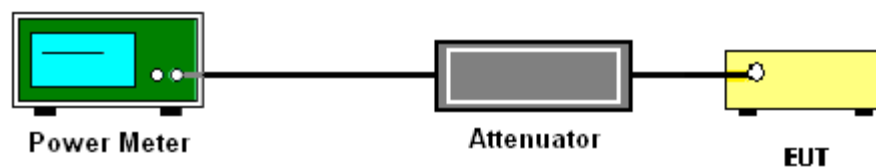



3.2.5 Test Result of Peak Output Power

Test Mode :	2.4GHz	Temperature :	23~24°C
Test Engineer :	Adonis Li	Relative Humidity :	47~48%

Mod.	Data Rate	N _{TX}	Channel	Freq. (MHz)	RF Output Power (dBm)	Power Limit (dBm)	DG (dBi)	Pass/Fail
11b	1Mbps	1	1	2412	14.43	30	-1.10	Pass
11b	1Mbps	1	6	2437	15.13	30	-1.10	Pass
11b	1Mbps	1	11	2462	16.02	30	-1.10	Pass
11g	6Mbps	1	1	2412	16.97	30	-1.10	Pass
11g	6Mbps	1	6	2437	17.57	30	-1.10	Pass
11g	6Mbps	1	11	2462	18.77	30	-1.10	Pass
HT20	MCS0	1	1	2412	15.82	30	-1.10	Pass
HT20	MCS0	1	6	2437	16.12	30	-1.10	Pass
HT20	MCS0	1	11	2462	17.19	30	-1.10	Pass

Note: Measured power (dBm) has offset with cable loss.



3.2.6 Test Result of Average output Power (Reporting Only)

Test Mode :	2.4GHz	Temperature :	23~24°C
Test Engineer :	Adonis Li	Relative Humidity :	47~48%

Mod.	Data Rate	N _{TX}	Channel	Freq. (MHz)	Duty Factor (dB)	Average Output Power (dBm)	Power Limit (dBm)	DG (dBi)	Pass/Fail
11b	1Mbps	1	1	2412	0.10	11.29	30	-1.10	Pass
11b	1Mbps	1	6	2437	0.10	12.15	30	-1.10	Pass
11b	1Mbps	1	11	2462	0.10	12.72	30	-1.10	Pass
11g	6Mbps	1	1	2412	0.59	7.74	30	-1.10	Pass
11g	6Mbps	1	6	2437	0.59	8.21	30	-1.10	Pass
11g	6Mbps	1	11	2462	0.59	8.92	30	-1.10	Pass
HT20	MCS0	1	1	2412	0.63	6.01	30	-1.10	Pass
HT20	MCS0	1	6	2437	0.63	6.38	30	-1.10	Pass
HT20	MCS0	1	11	2462	0.63	7.14	30	-1.10	Pass

Note: Measured power (dBm) has offset with cable loss and duty factor.

3.3 Power Spectral Density Measurement

3.3.1 Limit of Power Spectral Density

The peak power spectral density shall not be greater than 8dBm in any 3kHz band at any time interval of continuous transmission.

3.3.2 Measuring Instruments

The measuring equipment is listed in the section 4 of this test report.

3.3.3 Test Procedures

1. The testing follows Measurement Procedure 10.2 Method PKPSD of FCC KDB Publication No. 558074 D01 DTS Meas. Guidance v03r01
2. The RF output of EUT was connected to the spectrum analyzer by RF cable and attenuator. The path loss was compensated to the results for each measurement.
3. Set to the maximum power setting and enable the EUT transmit continuously.
4. Make the measurement with the spectrum analyzer's resolution bandwidth (RBW) = 3 kHz. Video bandwidth VBW = 10 kHz In order to make an accurate measurement, set the span to 1.5 times DTS Channel Bandwidth. (6dB BW)
5. Detector = peak, Sweep time = auto couple, Trace mode = max hold, Allow trace to fully stabilize. Use the peak marker function to determine the maximum power level.
6. Measure and record the results in the test report.

3.3.4 Test Setup

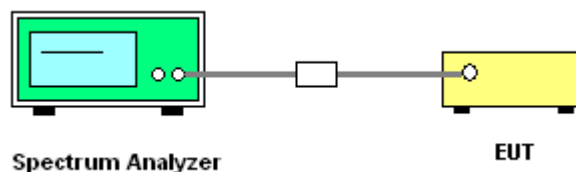



3.3.5 Test Result of Power Spectral Density

Test Mode :	2.4GHz	Temperature :	23~24°C
Test Engineer :	Adonis Li	Relative Humidity :	47~48%

Mod.	Data Rate	N _{TX}	Channel	Freq. (MHz)	Peak Power Density (dBm/3kHz)	Max. Limits (dBm/3kHz)	DG (dBi)	Pass/Fail
11b	1Mbps	1	1	2412	-11.06	8	-1.10	Pass
11b	1Mbps	1	6	2437	-10.15	8	-1.10	Pass
11b	1Mbps	1	11	2462	-9.53	8	-1.10	Pass
11g	6Mbps	1	1	2412	-18.70	8	-1.10	Pass
11g	6Mbps	1	6	2437	-18.60	8	-1.10	Pass
11g	6Mbps	1	11	2462	-17.51	8	-1.10	Pass
HT20	MCS0	1	1	2412	-20.50	8	-1.10	Pass
HT20	MCS0	1	6	2437	-20.15	8	-1.10	Pass
HT20	MCS0	1	11	2462	-19.92	8	-1.10	Pass

Note: Measured power density (dBm) has offset with cable loss.

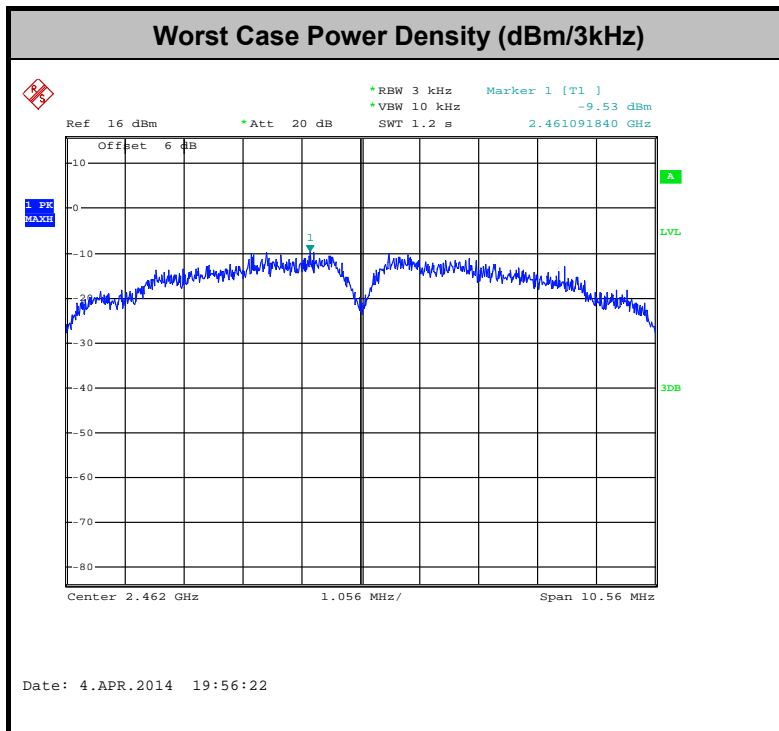

3.4 Conducted Band Edges and Spurious Emission Measurement

3.4.1 Limit of Conducted Band Edges and Spurious Emission Measurement

In any 100 kHz bandwidth outside of the authorized frequency band, the emissions which fall in the non-restricted bands shall be attenuated at least 20 dB / 30dB relative to the maximum PSD level in 100 kHz by RF conducted measurement and radiated emissions which fall in the restricted bands, as defined in Section 15.205(a), must also comply with the radiated emission limits specified in Section 15.209(a).

3.4.2 Measuring Instruments

The measuring equipment is listed in the section 4 of this test report.

3.4.3 Test Procedures

1. The testing follows FCC KDB Publication No. 558074 D01 DTS Meas. Guidance v03r01.
2. The RF output of EUT was connected to the spectrum analyzer by RF cable and attenuator. The path loss was compensated to the results for each measurement.
3. Set to the maximum power setting and enable the EUT transmit continuously.
4. Set RBW = 100 kHz, VBW=300 kHz, Peak Detector. Unwanted Emissions measured in any 100 kHz bandwidth outside of the authorized frequency band shall be attenuated by at least 20 dB relative to the maximum in-band peak PSD level in 100 kHz when maximum peak conducted output power procedure is used. If the transmitter complies with the conducted power limits based on the use of RMS averaging over a time interval, the attenuation required under this paragraph shall be 30 dB instead of 20 dB per 15.247(d).
5. Measure and record the results in the test report.
6. The RF fundamental frequency should be excluded against the limit line in the operating frequency band.

3.4.4 Test Setup

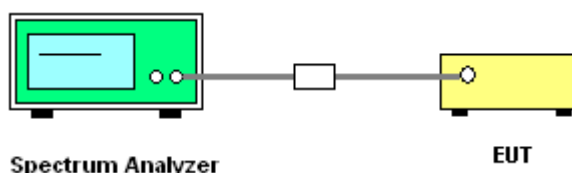



3.4.5 Test Result of Conducted Band Edges and Spurious Emission

Test Mode :	802.11b	Temperature :	23~24°C
Test Band :	2.4GHz Low	Relative Humidity :	47~48%
Test Channel :	01	Test Engineer :	Adonis Li

WLAN 802.11b Channel 01

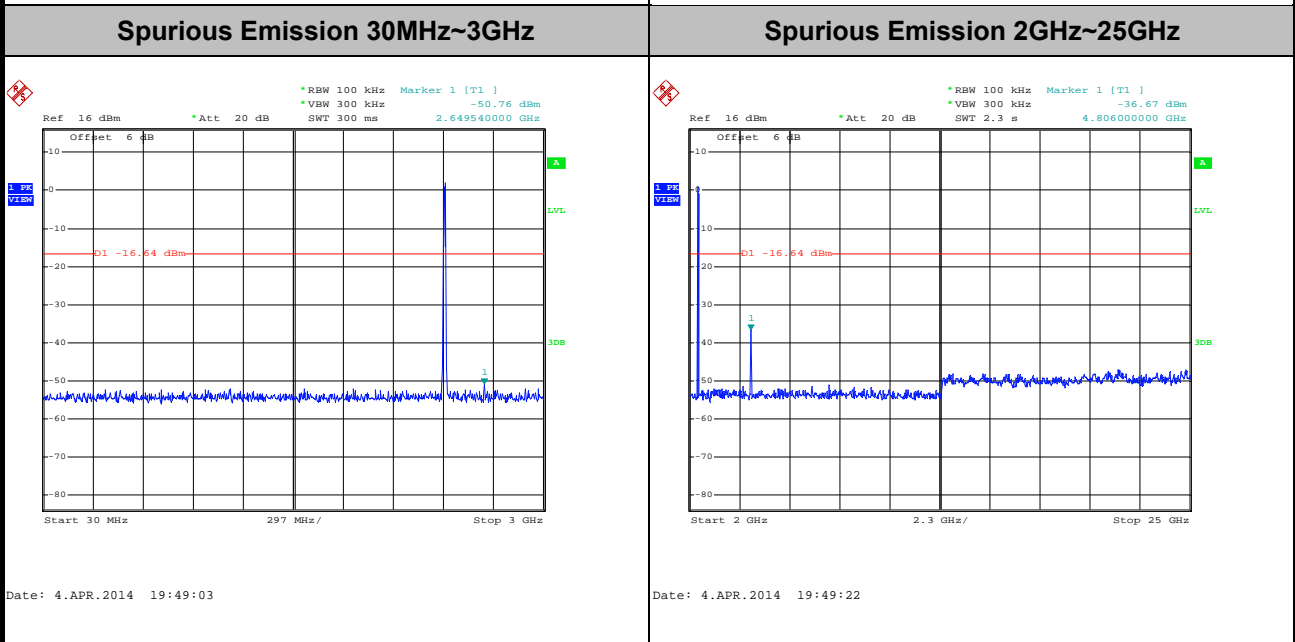
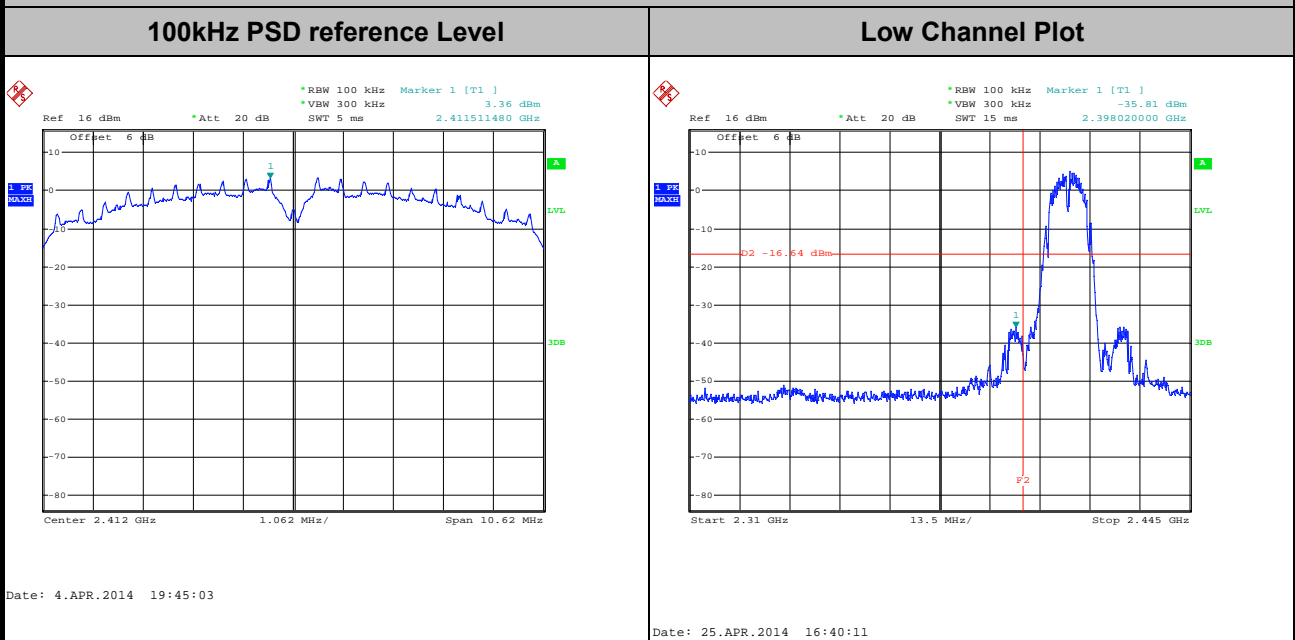



Test Mode :	802.11b	Temperature :	23~24°C
Test Band :	2.4GHz Mid	Relative Humidity :	47~48%
Test Channel :	06	Test Engineer :	Adonis Li

WLAN 802.11b Channel 06

100kHz PSD reference Level

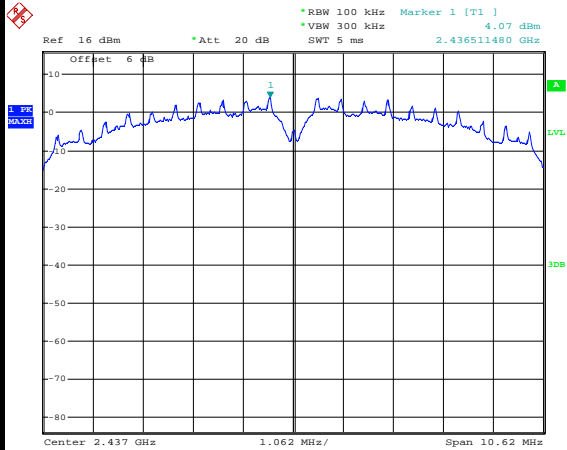

Date: 4.APR.2014 19:53:57

Spurious Emission 30MHz~3GHz

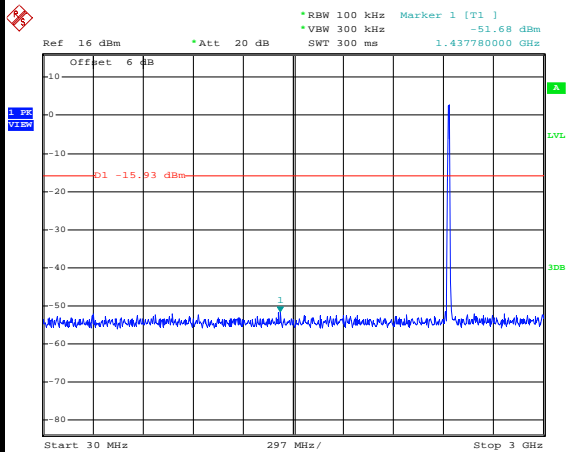

Date: 4.APR.2014 19:54:17

Spurious Emission 2GHz~25GHz

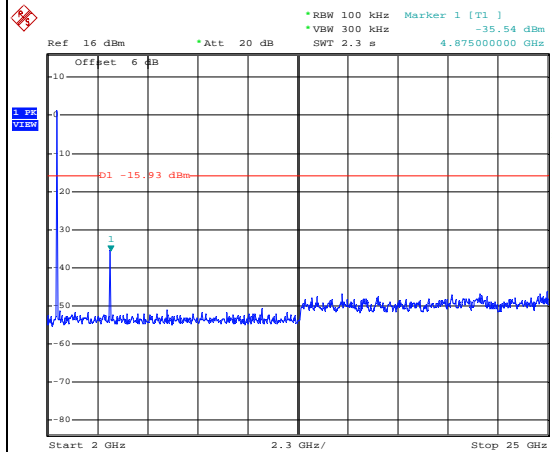

Date: 4.APR.2014 19:54:36



Test Mode :	802.11b	Temperature :	23~24°C
Test Band :	2.4GHz High	Relative Humidity :	47~48%
Test Channel :	11	Test Engineer :	Adonis Li

WLAN 802.11b Channel 11

100kHz PSD reference Level

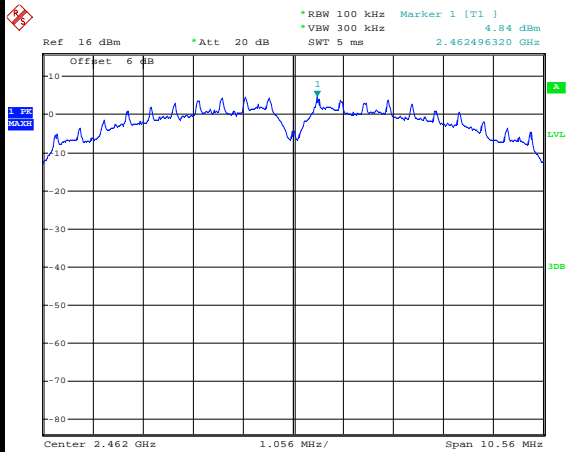

Date: 4.APR.2014 19:56:31

High Channel Plot

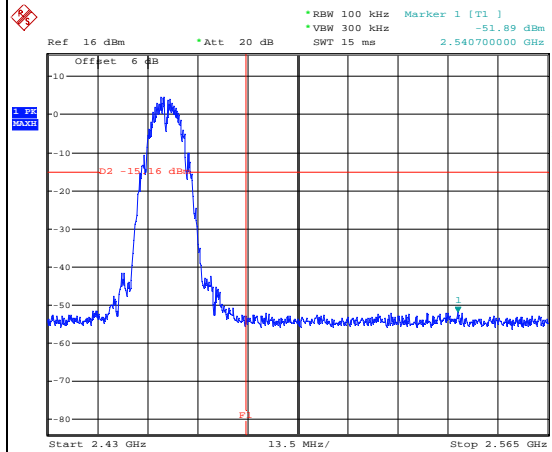

Date: 4.APR.2014 19:56:45

Spurious Emission 30MHz~3GHz

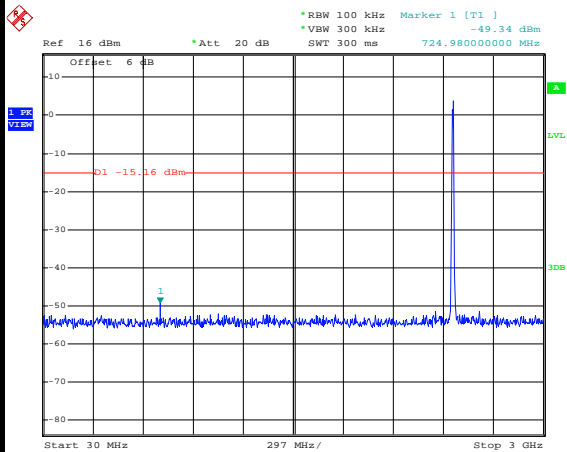

Date: 4.APR.2014 19:57:04

Spurious Emission 2GHz~25GHz

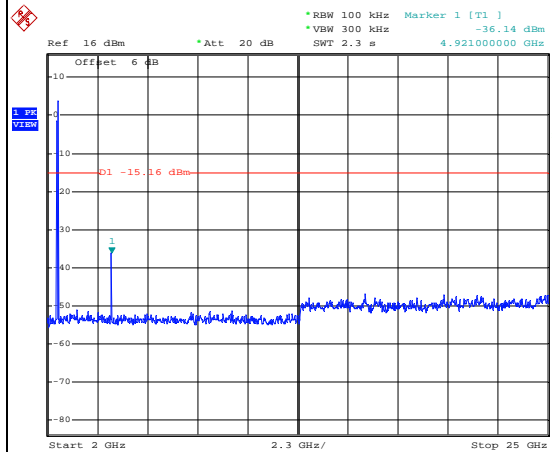

Date: 4.APR.2014 19:57:23



Test Mode :	802.11g	Temperature :	23~24°C
Test Band :	2.4GHz Low	Relative Humidity :	47~48%
Test Channel :	01	Test Engineer :	Adonis Li

WLAN 802.11g Channel 01

100kHz PSD reference Level

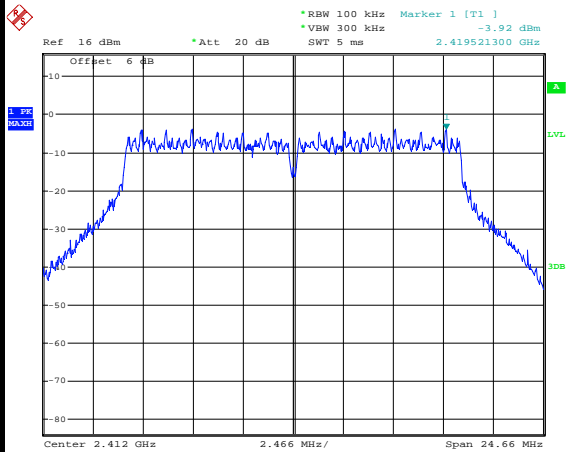

Date: 4.APR.2014 20:08:00

Low Channel Plot

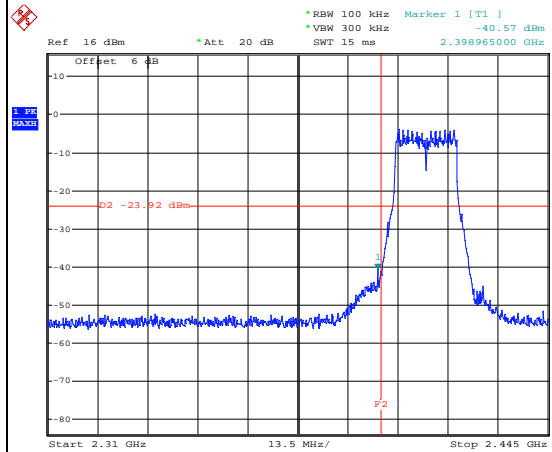

Date: 4.APR.2014 20:16:20

Spurious Emission 30MHz~3GHz

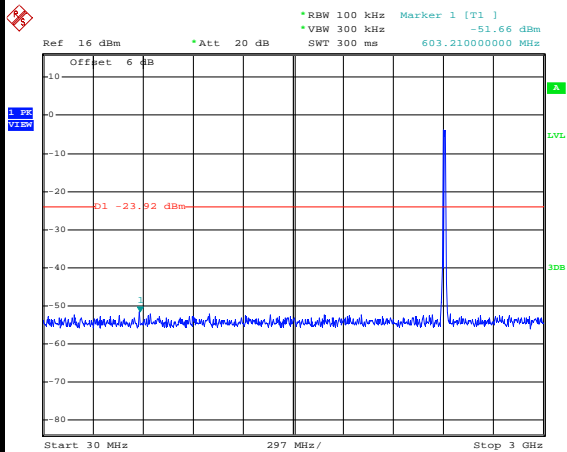

Date: 4.APR.2014 20:08:34

Spurious Emission 2GHz~25GHz

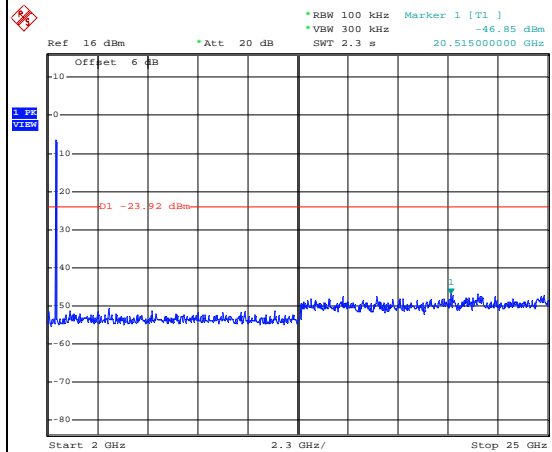

Date: 4.APR.2014 20:08:52



Test Mode :	802.11g	Temperature :	23~24°C
Test Band :	2.4GHz Mid	Relative Humidity :	47~48%
Test Channel :	06	Test Engineer :	Adonis Li

WLAN 802.11g Channel 06

100kHz PSD reference Level

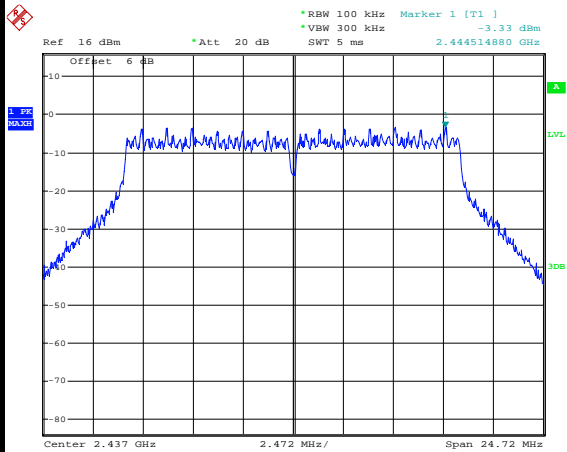

Date: 4.APR.2014 20:11:09

Spurious Emission 30MHz~3GHz

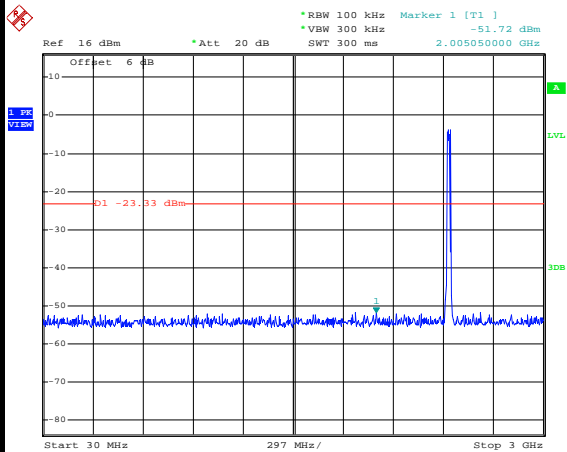

Date: 4.APR.2014 20:11:29

Spurious Emission 2GHz~25GHz

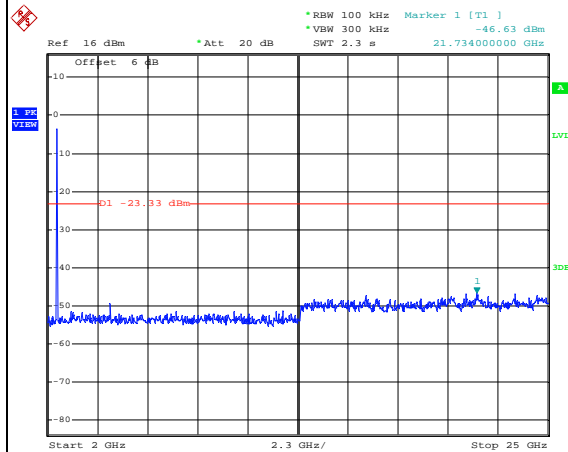

Date: 4.APR.2014 20:11:48



Test Mode :	802.11g	Temperature :	23~24°C
Test Band :	2.4GHz High	Relative Humidity :	47~48%
Test Channel :	11	Test Engineer :	Adonis Li

WLAN 802.11g Channel 11

100kHz PSD reference Level

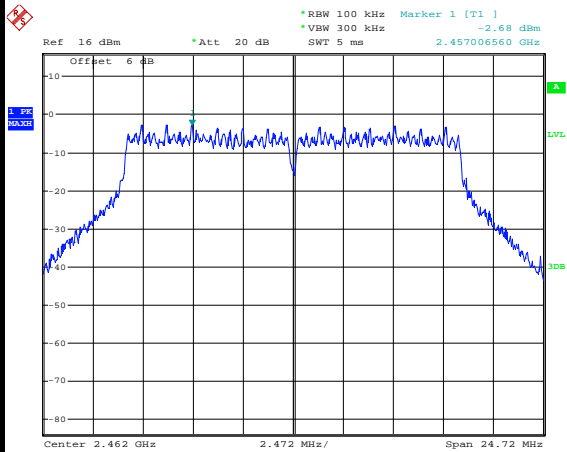

Date: 4.APR.2014 20:13:51

High Channel Plot

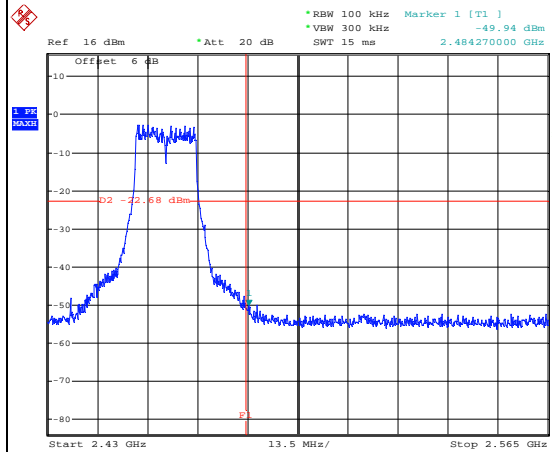

Date: 4.APR.2014 20:17:05

Spurious Emission 30MHz~3GHz

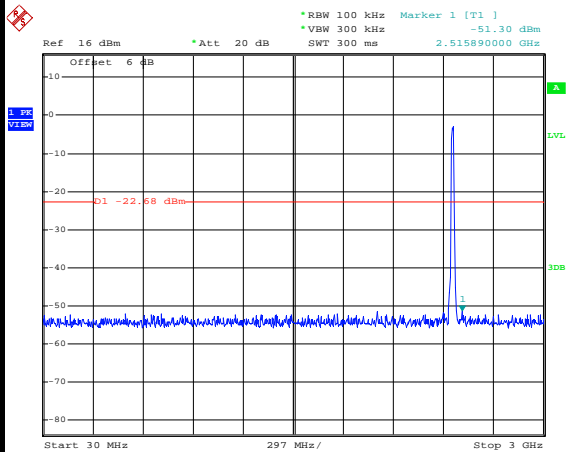

Date: 4.APR.2014 20:14:24

Spurious Emission 2GHz~25GHz

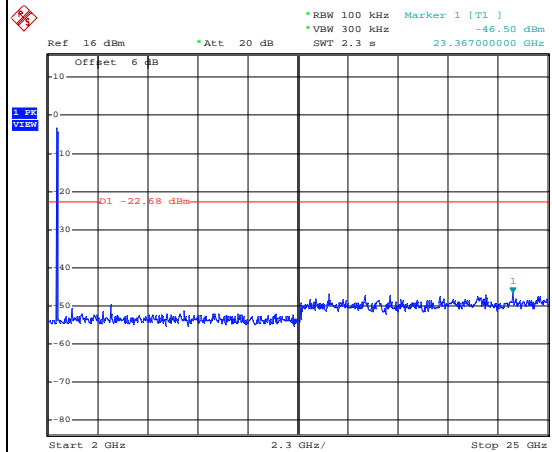

Date: 4.APR.2014 20:14:43



Test Mode :	802.11n HT20	Temperature :	23~24°C
Test Band :	2.4GHz Low	Relative Humidity :	47~48%
Test Channel :	01	Test Engineer :	Adonis Li

WLAN 802.11n HT20 Channel 01

100kHz PSD reference Level

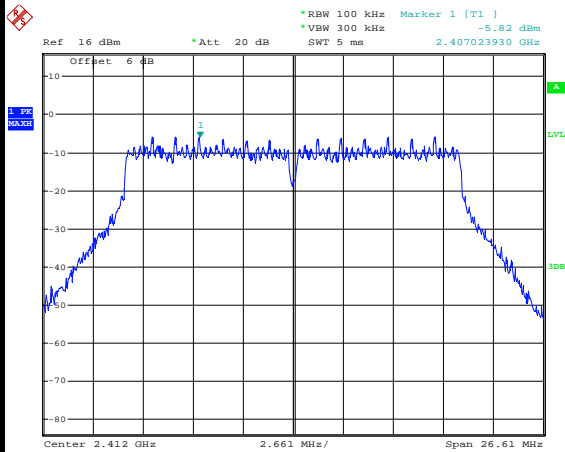

Date: 4.APR.2014 20:19:54

Low Channel Plot

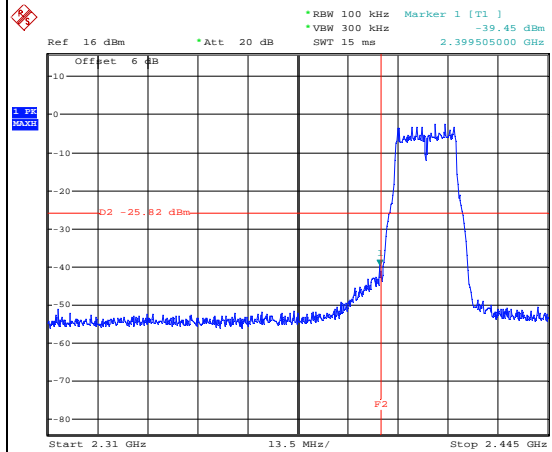

Date: 25.APR.2014 16:47:45

Spurious Emission 30MHz~3GHz

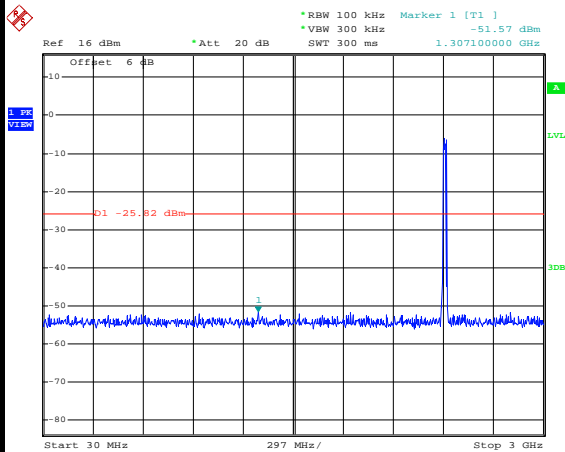

Date: 4.APR.2014 20:20:27

Spurious Emission 2GHz~25GHz

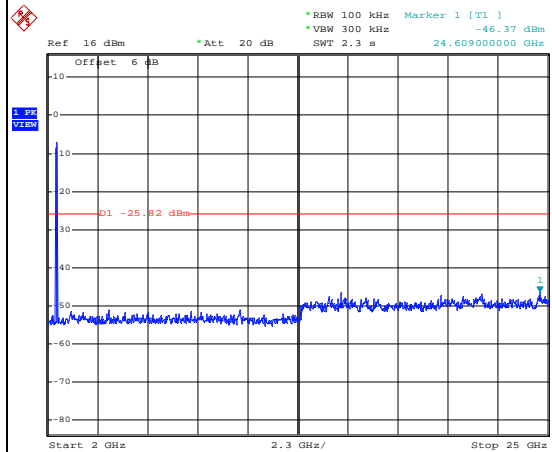

Date: 4.APR.2014 20:20:46



Test Mode :	802.11n HT20	Temperature :	23~24°C
Test Band :	2.4GHz Mid	Relative Humidity :	47~48%
Test Channel :	06	Test Engineer :	Adonis Li

WLAN 802.11n HT20 Channel 06

100kHz PSD reference Level

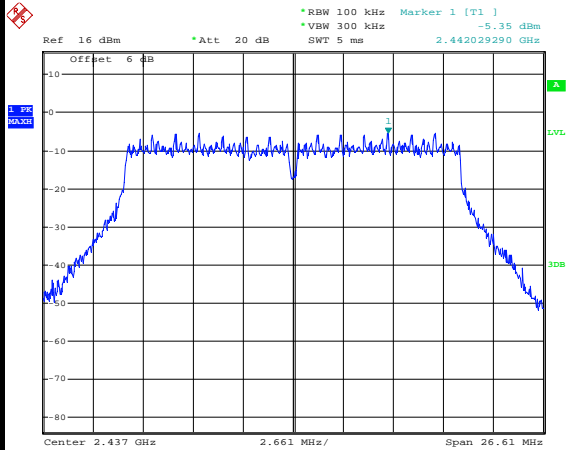

Date: 4.APR.2014 20:27:22

Spurious Emission 30MHz~3GHz

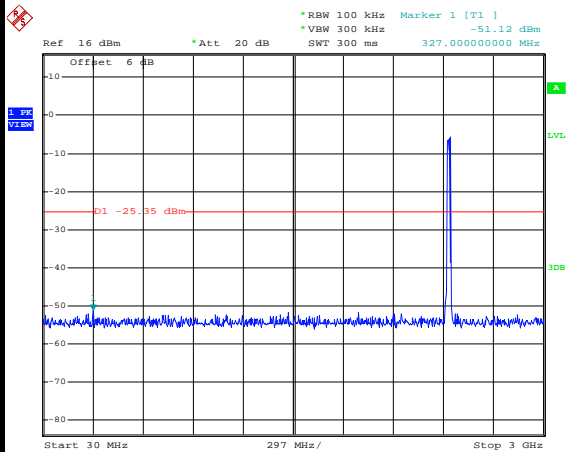

Date: 4.APR.2014 20:27:42

Spurious Emission 2GHz~25GHz

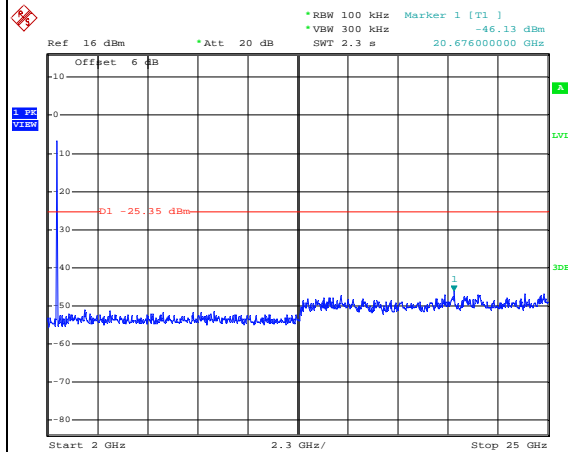

Date: 4.APR.2014 20:28:01



Test Mode :	802.11n HT20	Temperature :	23~24°C
Test Band :	2.4GHz High	Relative Humidity :	47~48%
Test Channel :	11	Test Engineer :	Adonis Li

WLAN 802.11n HT20 Channel 11

100kHz PSD reference Level

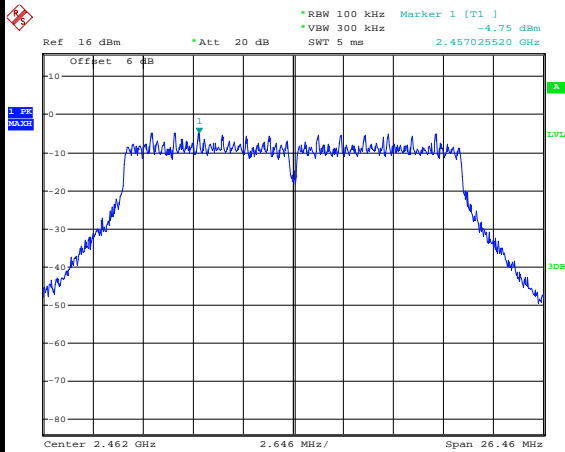

Date: 4.APR.2014 20:29:59

High Channel Plot

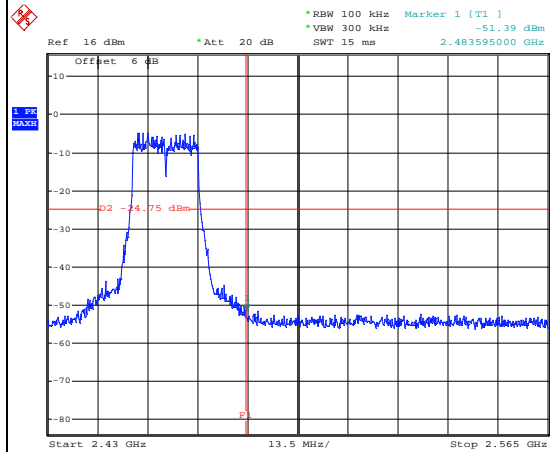

Date: 4.APR.2014 20:30:13

Spurious Emission 30MHz~3GHz

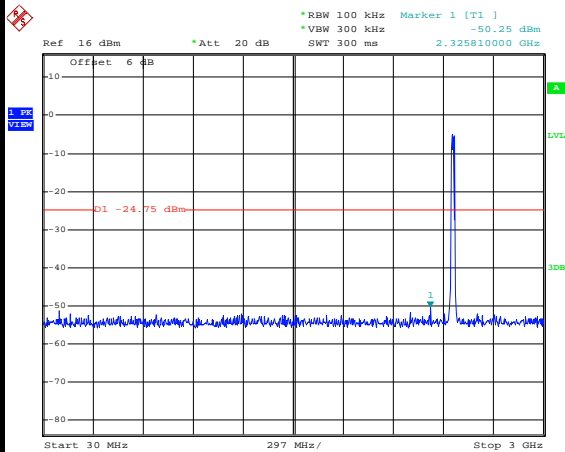

Date: 4.APR.2014 20:30:32

Spurious Emission 2GHz~25GHz

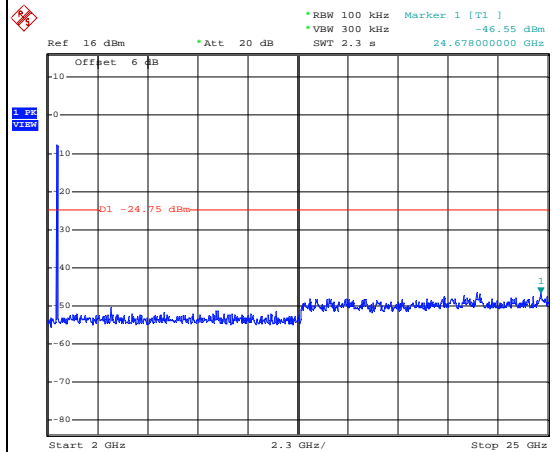

Date: 4.APR.2014 20:30:51



3.5 Radiated Band Edges and Spurious Emission Measurement

3.5.1 Limit of Radiated band edge and Spurious Emission Measurement

In any 100 kHz bandwidth outside the intentional radiator frequency band, all harmonics/spurious must be at least 20 dB below the highest emission level within the authorized band. If the output power of this device was measured by spectrum analyzer, the attenuation under this paragraph shall be 30 dB instead of 20 dB. In addition, radiated emissions which fall in the restricted bands must also comply with the FCC section 15.209 limits as below.

Frequency (MHz)	Field Strength (microvolts/meter)	Measurement Distance (meters)
0.009 – 0.490	2400/F(kHz)	300
0.490 – 1.705	24000/F(kHz)	30
1.705 – 30.0	30	30
30 – 88	100	3
88 – 216	150	3
216 - 960	200	3
Above 960	500	3

3.5.2 Measuring Instruments

The measuring equipment is listed in the section 4 of this test report.



3.5.3 Test Procedures

1. The testing follows FCC KDB Publication No. 558074 D01 DTS Meas. Guidance v03r01.
2. The EUT was arranged to its worst case and then tune the antenna tower (from 1 m to 4 m) and turntable (from 0 degree to 360 degrees) to find the maximum reading. A pre-amp and a high pass filter are used for the test in order to get better signal level.
3. The EUT was placed on a turntable with 0.8 meter above ground.
4. The EUT was set 3 meters from the interference receiving antenna, which was mounted on the top of a variable height antenna tower.
5. Corrected Reading: Antenna Factor + Cable Loss + Read Level - Preamp Factor = Level
6. For measurement below 1GHz, If the emission level of the EUT measured by the peak detector is 3 dB lower than the applicable limit, the peak emission level will be reported. Otherwise, the emission measurement will be repeated using the quasi-peak detector and reported.
7. Use the following spectrum analyzer settings:
 - (1) Span shall wide enough to fully capture the emission being measured;
 - (2) Set RBW=100 kHz for $f < 1$ GHz; $VBW \geq RBW$; Sweep = auto; Detector function = peak; Trace = max hold;
 - (3) Set RBW = 1 MHz, VBW= 3MHz for $f \geq 1$ GHz for peak measurement.

For average measurement:

 - $VBW = 10$ Hz, when duty cycle is no less than 98 percent.
 - $VBW \geq 1/T$, when duty cycle is less than 98 percent where T is the minimum transmission duration over which the transmitter is on and is transmitting at its maximum power control level for the tested mode of operation.

Band	Duty Cycle(%)	T(ms)	1/T(kHz)	VBW Setting
802.11b	97.63	8.240	0.121	300Hz
802.11g	87.26	1.370	0.730	1kHz
2.4GHz 802.11n HT20	86.41	1.272	0.786	1kHz

3.5.4 Test Setup

For radiated emissions below 30MHz

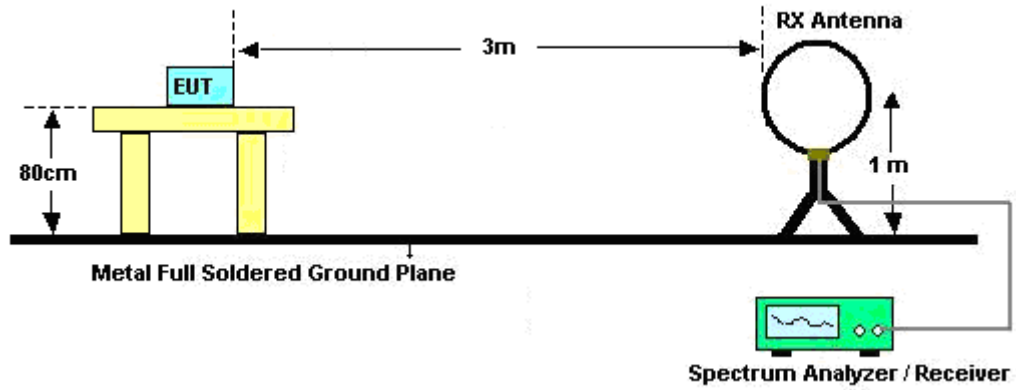

For radiated emissions from 30MHz to 1GHz

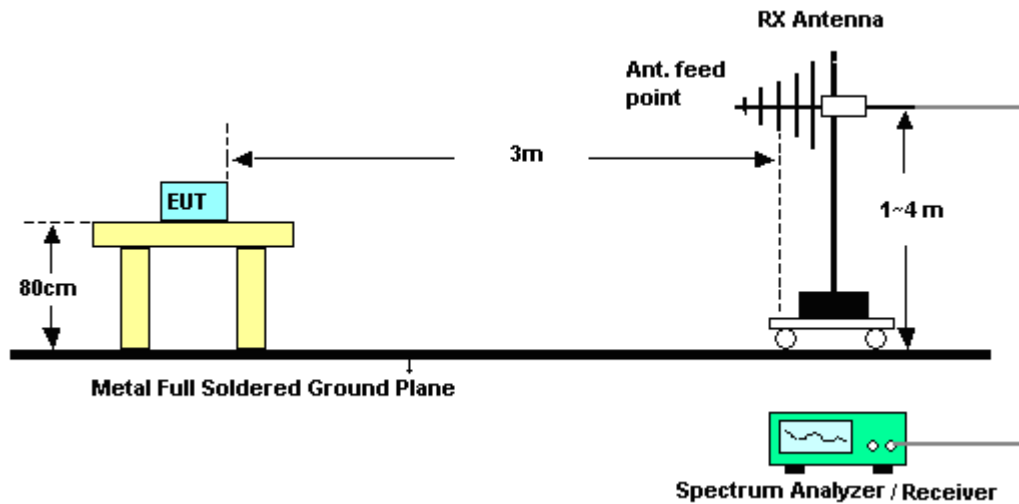

For radiated emissions above 1GHz

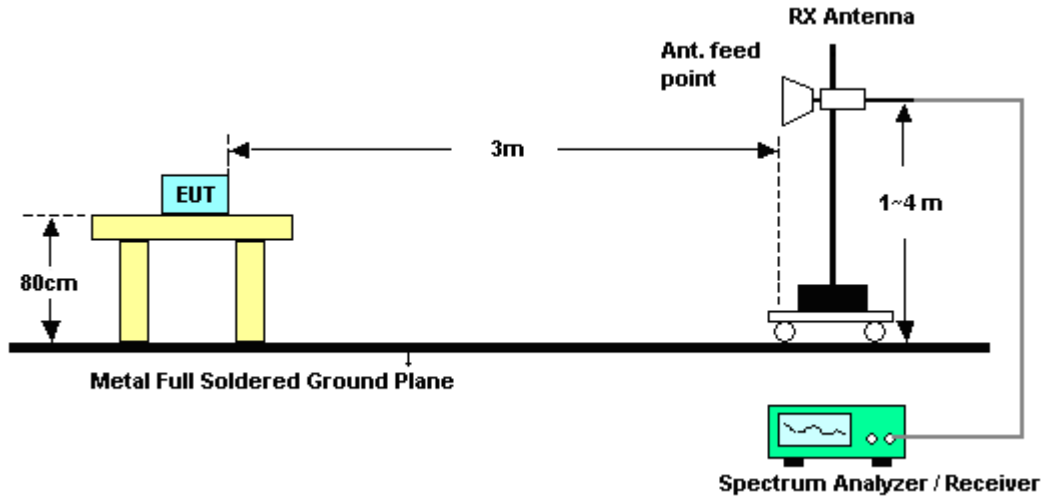

3.5.5 Test Results of Radiated Spurious Emissions (9kHz ~ 30MHz)

The low frequency, which started from 9 kHz to 30MHz, was pre-scanned and the result which was 20dB lower than the limit line per 15.31(o) was not reported.



3.5.6 Test Result of Radiated Spurious at Band Edges

Test Mode :	802.11b	Temperature :	22~23°C
Test Band :	Low	Relative Humidity :	42~43%
Test Channel :	01	Test Engineer :	Star Wei

ANTENNA POLARITY : HORIZONTAL										
Frequency (MHz)	Level (dBμV/m)	Over Limit (dB)	Limit Line (dBμV/m)	Read Level (dBμV)	Antenna Factor (dB)	Cable Loss (dB)	Preamp Factor (dB)	Ant Pos (cm)	Table Pos (deg)	Remark
2389.65	50.19	-23.81	74	47	32.86	3.59	33.26	121	336	Peak
2386.86	38.39	-15.61	54	35.2	32.86	3.59	33.26	121	336	Average

ANTENNA POLARITY : VERTICAL										
Frequency (MHz)	Level (dBμV/m)	Over Limit (dB)	Limit Line (dBμV/m)	Read Level (dBμV)	Antenna Factor (dB)	Cable Loss (dB)	Preamp Factor (dB)	Ant Pos (cm)	Table Pos (deg)	Remark
2382.09	48.78	-25.22	74	45.63	32.83	3.58	33.26	110	162	Peak
2387.58	35.54	-18.46	54	32.35	32.86	3.59	33.26	110	162	Average

Test Mode :	802.11b	Temperature :	22~23°C
Test Band :	High	Relative Humidity :	42~43%
Test Channel :	11	Test Engineer :	Star Wei

ANTENNA POLARITY : HORIZONTAL										
Frequency (MHz)	Level (dBμV/m)	Over Limit (dB)	Limit Line (dBμV/m)	Read Level (dBμV)	Antenna Factor (dB)	Cable Loss (dB)	Preamp Factor (dB)	Ant Pos (cm)	Table Pos (deg)	Remark
2494.6	54.1	-19.9	74	50.69	33.05	3.66	33.3	100	206	Peak
2497.93	36.61	-17.39	54	33.2	33.05	3.66	33.3	100	206	Average

ANTENNA POLARITY : VERTICAL										
Frequency (MHz)	Level (dBμV/m)	Over Limit (dB)	Limit Line (dBμV/m)	Read Level (dBμV)	Antenna Factor (dB)	Cable Loss (dB)	Preamp Factor (dB)	Ant Pos (cm)	Table Pos (deg)	Remark
2492.71	54.41	-19.59	74	51	33.05	3.66	33.3	100	148	Peak
2496.4	36.6	-17.4	54	33.19	33.05	3.66	33.3	100	148	Average



Test Mode :	802.11g	Temperature :	22~23°C
Test Band :	Low	Relative Humidity :	42~43%
Test Channel :	01	Test Engineer :	Star Wei

ANTENNA POLARITY : HORIZONTAL										
Frequency (MHz)	Level (dBμV/m)	Over Limit (dB)	Limit Line (dBμV/m)	Read Level (dBμV)	Antenna Factor (dB)	Cable Loss (dB)	Preamp Factor (dB)	Ant Pos (cm)	Table Pos (deg)	Remark
2389.65	63.33	-10.67	74	60.14	32.86	3.59	33.26	123	325	Peak
2389.92	46.1	-7.9	54	42.91	32.86	3.59	33.26	123	325	Average

ANTENNA POLARITY : VERTICAL										
Frequency (MHz)	Level (dBμV/m)	Over Limit (dB)	Limit Line (dBμV/m)	Read Level (dBμV)	Antenna Factor (dB)	Cable Loss (dB)	Preamp Factor (dB)	Ant Pos (cm)	Table Pos (deg)	Remark
2389.65	56.73	-17.27	74	53.54	32.86	3.59	33.26	188	163	Peak
2389.92	40.98	-13.02	54	37.79	32.86	3.59	33.26	188	163	Average

Test Mode :	802.11g	Temperature :	22~23°C
Test Band :	High	Relative Humidity :	42~43%
Test Channel :	11	Test Engineer :	Star Wei

ANTENNA POLARITY : HORIZONTAL										
Frequency (MHz)	Level (dBμV/m)	Over Limit (dB)	Limit Line (dBμV/m)	Read Level (dBμV)	Antenna Factor (dB)	Cable Loss (dB)	Preamp Factor (dB)	Ant Pos (cm)	Table Pos (deg)	Remark
2483.65	68.09	-5.91	74	64.72	33.01	3.65	33.29	175	334	Peak
2483.92	47.56	-6.44	54	44.19	33.01	3.65	33.29	175	334	Average

ANTENNA POLARITY : VERTICAL										
Frequency (MHz)	Level (dBμV/m)	Over Limit (dB)	Limit Line (dBμV/m)	Read Level (dBμV)	Antenna Factor (dB)	Cable Loss (dB)	Preamp Factor (dB)	Ant Pos (cm)	Table Pos (deg)	Remark
2484.13	61.87	-12.13	74	58.5	33.01	3.65	33.29	100	169	Peak
2483.5	42.47	-11.53	54	39.1	33.01	3.65	33.29	100	169	Average



Test Mode :	802.11n HT20	Temperature :	22~23°C
Test Band :	Low	Relative Humidity :	42~43%
Test Channel :	01	Test Engineer :	Star Wei

ANTENNA POLARITY : HORIZONTAL										
Frequency (MHz)	Level (dBμV/m)	Over Limit (dB)	Limit Line (dBμV/m)	Read Level (dBμV)	Antenna Factor (dB)	Cable Loss (dB)	Preamp Factor (dB)	Ant Pos (cm)	Table Pos (deg)	Remark
2389.65	60.41	-13.59	74	57.22	32.86	3.59	33.26	100	329	Peak
2389.65	44.1	-9.9	54	40.91	32.86	3.59	33.26	100	329	Average

ANTENNA POLARITY : VERTICAL										
Frequency (MHz)	Level (dBμV/m)	Over Limit (dB)	Limit Line (dBμV/m)	Read Level (dBμV)	Antenna Factor (dB)	Cable Loss (dB)	Preamp Factor (dB)	Ant Pos (cm)	Table Pos (deg)	Remark
2389.65	53.77	-20.23	74	50.58	32.86	3.59	33.26	100	173	Peak
2389.92	40.01	-13.99	54	36.82	32.86	3.59	33.26	100	173	Average

Test Mode :	802.11n HT20	Temperature :	22~23°C
Test Band :	High	Relative Humidity :	42~43%
Test Channel :	11	Test Engineer :	Star Wei

ANTENNA POLARITY : HORIZONTAL										
Frequency (MHz)	Level (dBμV/m)	Over Limit (dB)	Limit Line (dBμV/m)	Read Level (dBμV)	Antenna Factor (dB)	Cable Loss (dB)	Preamp Factor (dB)	Ant Pos (cm)	Table Pos (deg)	Remark
2484.34	61.51	-12.49	74	58.14	33.01	3.65	33.29	100	314	Peak
2483.59	42.61	-11.39	54	39.24	33.01	3.65	33.29	100	314	Average

ANTENNA POLARITY : VERTICAL										
Frequency (MHz)	Level (dBμV/m)	Over Limit (dB)	Limit Line (dBμV/m)	Read Level (dBμV)	Antenna Factor (dB)	Cable Loss (dB)	Preamp Factor (dB)	Ant Pos (cm)	Table Pos (deg)	Remark
2484.16	57.52	-16.48	74	54.15	33.01	3.65	33.29	100	179	Peak
2483.62	39.92	-14.08	54	36.55	33.01	3.65	33.29	100	179	Average



3.5.7 Test Result of Radiated Spurious Emission (30MHz ~ 10th Harmonic)

Note: Pre-scanned all test modes and only choose the worst case mode recorded in the test report for radiated spurious emission below 1GHz.

Test Mode :	802.11b	Temperature :	22~23°C
Test Channel :	01	Relative Humidity :	42~43%
Test Engineer :	Star Wei	Polarization :	Horizontal
Remark :	1. 2412 MHz is fundamental signal which can be ignored. 2. Average measurement was not performed if peak level went lower than the average limit.		

Frequency (MHz)	Level (dBμV/m)	Over Limit (dB)	Limit Line (dBμV/m)	Read Level (dBμV)	Antenna Factor (dB)	Cable Loss (dB)	Preamp Factor (dB)	Ant Pos (cm)	Table Pos (deg)	Remark
2412	109.37	-	-	106.14	32.89	3.61	33.27	121	333	Peak
2412	105.05	-	-	101.82	32.89	3.61	33.27	121	333	Average
4824	48.53	-25.47	74	41.91	35.17	5.25	33.8	100	203	Peak

Test Mode :	802.11b	Temperature :	22~23°C
Test Channel :	01	Relative Humidity :	42~43%
Test Engineer :	Star Wei	Polarization :	Vertical
Remark :	1. 2412 MHz is fundamental signal which can be ignored. 2. Average measurement was not performed if peak level went lower than the average limit.		

Frequency (MHz)	Level (dBμV/m)	Over Limit (dB)	Limit Line (dBμV/m)	Read Level (dBμV)	Antenna Factor (dB)	Cable Loss (dB)	Preamp Factor (dB)	Ant Pos (cm)	Table Pos (deg)	Remark
2412	103.05	-	-	99.82	32.89	3.61	33.27	105	174	Peak
2412	98.62	-	-	95.39	32.89	3.61	33.27	105	174	Average
4824	47.66	-26.34	74	41.04	35.17	5.25	33.8	100	169	Peak



Test Mode :	802.11b	Temperature :	22~23°C
Test Channel :	06	Relative Humidity :	42~43%
Test Engineer :	Star Wei	Polarization :	Horizontal
Remark :	1. 2437 MHz is fundamental signal which can be ignored. 2. Average measurement was not performed if peak level went lower than the average limit.		

Frequency (MHz)	Level (dBμV/m)	Over Limit (dB)	Limit Line (dBμV/m)	Read Level (dBμV)	Antenna Factor (dB)	Cable Loss (dB)	Preamp Factor (dB)	Ant Pos (cm)	Table Pos (deg)	Remark
2437	109.73	-	-	106.43	32.95	3.63	33.28	120	332	Peak
2437	105.36	-	-	102.06	32.95	3.63	33.28	120	332	Average
4874	47.74	-26.26	74	41.08	35.18	5.28	33.8	101	226	Peak
7311	47.04	-26.96	74	38.36	36.2	6.61	34.13	100	63	Peak

Test Mode :	802.11b	Temperature :	22~23°C
Test Channel :	06	Relative Humidity :	42~43%
Test Engineer :	Star Wei	Polarization :	Vertical
Remark :	1. 2437 MHz is fundamental signal which can be ignored. 2. Average measurement was not performed if peak level went lower than the average limit.		

Frequency (MHz)	Level (dBμV/m)	Over Limit (dB)	Limit Line (dBμV/m)	Read Level (dBμV)	Antenna Factor (dB)	Cable Loss (dB)	Preamp Factor (dB)	Ant Pos (cm)	Table Pos (deg)	Remark
2437	103.86	-	-	100.56	32.95	3.63	33.28	100	175	Peak
2437	99.31	-	-	96.01	32.95	3.63	33.28	100	175	Average
4874	47.55	-26.45	74	40.89	35.18	5.28	33.8	120	162	Peak
7311	47.01	-26.99	74	38.33	36.2	6.61	34.13	100	162	Peak



Test Mode :	802.11b	Temperature :	22~23°C
Test Channel :	11	Relative Humidity :	42~43%
Test Engineer :	Star Wei	Polarization :	Horizontal
Remark :	1. 2462 MHz is fundamental signal which can be ignored. 2. Average measurement was not performed if peak level went lower than the average limit.		

Frequency (MHz)	Level (dBμV/m)	Over Limit (dB)	Limit Line (dBμV/m)	Read Level (dBμV)	Antenna Factor (dB)	Cable Loss (dB)	Preamp Factor (dB)	Ant Pos (cm)	Table Pos (deg)	Remark
2462	108.49	-	-	105.16	32.98	3.64	33.29	122	336	Peak
2462	103.96	-	-	100.63	32.98	3.64	33.29	122	336	Average
4924	47.53	-26.47	74	40.83	35.19	5.31	33.8	100	119	Peak
7386	47.63	-26.37	74	38.85	36.24	6.7	34.16	119	56	Peak

Test Mode :	802.11b	Temperature :	22~23°C
Test Channel :	11	Relative Humidity :	42~43%
Test Engineer :	Star Wei	Polarization :	Vertical
Remark :	1. 2462 MHz is fundamental signal which can be ignored. 2. Average measurement was not performed if peak level went lower than the average limit.		

Frequency (MHz)	Level (dBμV/m)	Over Limit (dB)	Limit Line (dBμV/m)	Read Level (dBμV)	Antenna Factor (dB)	Cable Loss (dB)	Preamp Factor (dB)	Ant Pos (cm)	Table Pos (deg)	Remark
2462	102.08	-	-	98.75	32.98	3.64	33.29	126	175	Peak
2462	97.87	-	-	94.54	32.98	3.64	33.29	126	175	Average
4924	47	-27	74	40.3	35.19	5.31	33.8	162	119	Peak
7386	47.28	-26.72	74	38.5	36.24	6.7	34.16	162	189	Peak



Test Mode :	802.11g	Temperature :	22~23°C
Test Channel :	01	Relative Humidity :	42~43%
Test Engineer :	Star Wei	Polarization :	Horizontal
Remark :	1. 2412 MHz is fundamental signal which can be ignored. 2. Average measurement was not performed if peak level went lower than the average limit.		

Frequency (MHz)	Level (dBμV/m)	Over Limit (dB)	Limit Line (dBμV/m)	Read Level (dBμV)	Antenna Factor (dB)	Cable Loss (dB)	Preamp Factor (dB)	Ant Pos (cm)	Table Pos (deg)	Remark
2412	107.65	-	-	104.42	32.89	3.61	33.27	100	330	Peak
2412	96.8	-	-	93.57	32.89	3.61	33.27	100	330	Average
4824	47.13	-26.87	74	40.51	35.17	5.25	33.8	102	332	Peak

Test Mode :	802.11g	Temperature :	22~23°C
Test Channel :	01	Relative Humidity :	42~43%
Test Engineer :	Star Wei	Polarization :	Vertical
Remark :	1. 2412 MHz is fundamental signal which can be ignored. 2. Average measurement was not performed if peak level went lower than the average limit.		

Frequency (MHz)	Level (dBμV/m)	Over Limit (dB)	Limit Line (dBμV/m)	Read Level (dBμV)	Antenna Factor (dB)	Cable Loss (dB)	Preamp Factor (dB)	Ant Pos (cm)	Table Pos (deg)	Remark
2412	102.52	-	-	99.29	32.89	3.61	33.27	126	166	Peak
2412	91.55	-	-	88.32	32.89	3.61	33.27	126	166	Average
4824	47.34	-26.66	74	40.72	35.17	5.25	33.8	162	339	Peak



Test Mode :	802.11g	Temperature :	22~23°C
Test Channel :	06	Relative Humidity :	42~43%
Test Engineer :	Star Wei	Polarization :	Horizontal
Remark :	1. 2437 MHz is fundamental signal which can be ignored. 2. Average measurement was not performed if peak level went lower than the average limit.		

Frequency (MHz)	Level (dBμV/m)	Over Limit (dB)	Limit Line (dBμV/m)	Read Level (dBμV)	Antenna Factor (dB)	Cable Loss (dB)	Preamp Factor (dB)	Ant Pos (cm)	Table Pos (deg)	Remark
2437	107.31	-	-	104.01	32.95	3.63	33.28	100	337	Peak
2437	96.55	-	-	93.25	32.95	3.63	33.28	100	337	Average
4874	46.21	-27.79	74	39.55	35.18	5.28	33.8	133	145	Peak
7311	46.83	-27.17	74	38.15	36.2	6.61	34.13	100	198	Peak

Test Mode :	802.11g	Temperature :	22~23°C
Test Channel :	06	Relative Humidity :	42~43%
Test Engineer :	Star Wei	Polarization :	Vertical
Remark :	1. 2437 MHz is fundamental signal which can be ignored. 2. Average measurement was not performed if peak level went lower than the average limit.		

Frequency (MHz)	Level (dBμV/m)	Over Limit (dB)	Limit Line (dBμV/m)	Read Level (dBμV)	Antenna Factor (dB)	Cable Loss (dB)	Preamp Factor (dB)	Ant Pos (cm)	Table Pos (deg)	Remark
2437	102.22	-	-	98.92	32.95	3.63	33.28	100	158	Peak
2437	90.31	-	-	87.01	32.95	3.63	33.28	100	158	Average
4874	45.8	-28.2	74	39.14	35.18	5.28	33.8	133	285	Peak
7311	45.97	-28.03	74	37.29	36.2	6.61	34.13	162	78	Peak



Test Mode :	802.11g	Temperature :	22~23°C
Test Channel :	11	Relative Humidity :	42~43%
Test Engineer :	Star Wei	Polarization :	Horizontal
Remark :	1. 2462 MHz is fundamental signal which can be ignored. 2. Average measurement was not performed if peak level went lower than the average limit.		

Frequency (MHz)	Level (dBμV/m)	Over Limit (dB)	Limit Line (dBμV/m)	Read Level (dBμV)	Antenna Factor (dB)	Cable Loss (dB)	Preamp Factor (dB)	Ant Pos (cm)	Table Pos (deg)	Remark
30	22.96	-17.04	40	38.05	18	0.48	33.57	155	147	Peak
128.94	23.97	-19.53	43.5	44.81	11.71	1.04	33.59	-	-	Peak
196.84	23.29	-20.21	43.5	46.7	8.86	1.29	33.56	-	-	Peak
288.02	22.54	-23.46	46	41.55	12.82	1.56	33.39	-	-	Peak
386.96	21.94	-24.06	46	37.79	15.68	1.79	33.32	-	-	Peak
460.68	28.68	-17.32	46	43.46	16.45	1.96	33.19	-	-	Peak
2462	108.34	-	-	105.01	32.98	3.64	33.29	143	332	Peak
2462	97.11	-	-	93.78	32.98	3.64	33.29	143	332	Average
4924	46.69	-27.31	74	39.99	35.19	5.31	33.8	163	221	Peak
7386	46.73	-27.27	74	37.95	36.24	6.7	34.16	141	174	Peak



Test Mode :	802.11g	Temperature :	22~23°C
Test Channel :	11	Relative Humidity :	42~43%
Test Engineer :	Star Wei	Polarization :	Vertical
Remark :	1. 2462 MHz is fundamental signal which can be ignored. 2. Average measurement was not performed if peak level went lower than the average limit.		

Frequency (MHz)	Level (dBμV/m)	Over Limit (dB)	Limit Line (dBμV/m)	Read Level (dBμV)	Antenna Factor (dB)	Cable Loss (dB)	Preamp Factor (dB)	Ant Pos (cm)	Table Pos (deg)	Remark
32.91	25.93	-14.07	40	42.96	16.04	0.52	33.59	100	200	Peak
109.54	23.08	-20.42	43.5	43.91	11.8	0.98	33.61	-	-	Peak
128.94	25.18	-18.32	43.5	46.02	11.71	1.04	33.59	-	-	Peak
403.45	16.97	-29.03	46	32.4	16.02	1.85	33.3	-	-	Peak
467.47	21.4	-24.6	46	36.03	16.57	1.98	33.18	-	-	Peak
773.99	19.65	-26.35	46	29.95	19.88	2.53	32.71	-	-	Peak
2462	101.58	-	-	98.25	32.98	3.64	33.29	100	151	Peak
2462	90.6	-	-	87.27	32.98	3.64	33.29	100	151	Average
4924	47.01	-26.99	74	40.31	35.19	5.31	33.8	165	96	Peak
7386	47.65	-26.35	74	38.87	36.24	6.7	34.16	107	133	Peak



Test Mode :	2.4GHz 802.11n HT20	Temperature :	22~23°C
Test Channel :	01	Relative Humidity :	42~43%
Test Engineer :	Star Wei	Polarization :	Horizontal
Remark :	1. 2412 MHz is fundamental signal which can be ignored. 2. Average measurement was not performed if peak level went lower than the average limit.		

Frequency (MHz)	Level (dBμV/m)	Over Limit (dB)	Limit Line (dBμV/m)	Read Level (dBμV)	Antenna Factor (dB)	Cable Loss (dB)	Preamp Factor (dB)	Ant Pos (cm)	Table Pos (deg)	Remark
2412	105.63	-	-	102.4	32.89	3.61	33.27	100	328	Peak
2412	94.42	-	-	91.19	32.89	3.61	33.27	100	328	Average
4824	45.99	-28.01	74	39.37	35.17	5.25	33.8	118	44	Peak

Test Mode :	2.4GHz 802.11n HT20	Temperature :	22~23°C
Test Channel :	01	Relative Humidity :	42~43%
Test Engineer :	Star Wei	Polarization :	Vertical
Remark :	1. 2412 MHz is fundamental signal which can be ignored. 2. Average measurement was not performed if peak level went lower than the average limit.		

Frequency (MHz)	Level (dBμV/m)	Over Limit (dB)	Limit Line (dBμV/m)	Read Level (dBμV)	Antenna Factor (dB)	Cable Loss (dB)	Preamp Factor (dB)	Ant Pos (cm)	Table Pos (deg)	Remark
2412	99.23	-	-	96	32.89	3.61	33.27	106	171	Peak
2412	88.83	-	-	85.6	32.89	3.61	33.27	106	171	Average
4824	46.87	-27.13	74	40.25	35.17	5.25	33.8	122	185	Peak



Test Mode :	2.4GHz 802.11n HT20	Temperature :	22~23°C
Test Channel :	06	Relative Humidity :	42~43%
Test Engineer :	Star Wei	Polarization :	Horizontal
Remark :	1. 2437 MHz is fundamental signal which can be ignored. 2. Average measurement was not performed if peak level went lower than the average limit.		

Frequency (MHz)	Level (dBμV/m)	Over Limit (dB)	Limit Line (dBμV/m)	Read Level (dBμV)	Antenna Factor (dB)	Cable Loss (dB)	Preamp Factor (dB)	Ant Pos (cm)	Table Pos (deg)	Remark
2437	106.2	-	-	102.9	32.95	3.63	33.28	100	336	Peak
2437	94.46	-	-	91.16	32.95	3.63	33.28	100	336	Average
4874	47.24	-26.76	74	40.58	35.18	5.28	33.8	100	211	Peak
7311	46.89	-27.11	74	38.21	36.2	6.61	34.13	122	151	Peak

Test Mode :	2.4GHz 802.11n HT20	Temperature :	22~23°C
Test Channel :	06	Relative Humidity :	42~43%
Test Engineer :	Star Wei	Polarization :	Vertical
Remark :	1. 2437 MHz is fundamental signal which can be ignored. 2. Average measurement was not performed if peak level went lower than the average limit.		

Frequency (MHz)	Level (dBμV/m)	Over Limit (dB)	Limit Line (dBμV/m)	Read Level (dBμV)	Antenna Factor (dB)	Cable Loss (dB)	Preamp Factor (dB)	Ant Pos (cm)	Table Pos (deg)	Remark
2437	99.68	-	-	96.38	32.95	3.63	33.28	100	172	Peak
2437	87.93	-	-	84.63	32.95	3.63	33.28	100	172	Average
4874	46.37	-27.63	74	39.71	35.18	5.28	33.8	100	169	Peak
7311	46.78	-27.22	74	38.1	36.2	6.61	34.13	198	284	Peak



Test Mode :	2.4GHz 802.11n HT20	Temperature :	22~23°C
Test Channel :	11	Relative Humidity :	42~43%
Test Engineer :	Star Wei	Polarization :	Horizontal
Remark :	1. 2462 MHz is fundamental signal which can be ignored. 2. Average measurement was not performed if peak level went lower than the average limit.		

Frequency (MHz)	Level (dBμV/m)	Over Limit (dB)	Limit Line (dBμV/m)	Read Level (dBμV)	Antenna Factor (dB)	Cable Loss (dB)	Preamp Factor (dB)	Ant Pos (cm)	Table Pos (deg)	Remark
2462	104.27	-	-	100.94	32.98	3.64	33.29	100	331	Peak
2462	92.73	-	-	89.4	32.98	3.64	33.29	100	331	Average
4924	46.94	-27.06	74	40.24	35.19	5.31	33.8	102	228	Peak
7386	46.31	-27.69	74	37.53	36.24	6.7	34.16	122	68	Peak

Test Mode :	2.4GHz 802.11n HT20	Temperature :	22~23°C
Test Channel :	11	Relative Humidity :	42~43%
Test Engineer :	Star Wei	Polarization :	Vertical
Remark :	1. 2462 MHz is fundamental signal which can be ignored. 2. Average measurement was not performed if peak level went lower than the average limit.		

Frequency (MHz)	Level (dBμV/m)	Over Limit (dB)	Limit Line (dBμV/m)	Read Level (dBμV)	Antenna Factor (dB)	Cable Loss (dB)	Preamp Factor (dB)	Ant Pos (cm)	Table Pos (deg)	Remark
2462	99.27	-	-	95.94	32.98	3.64	33.29	105	151	Peak
2462	88.15	-	-	84.82	32.98	3.64	33.29	105	151	Average
4924	45.92	-28.08	74	39.22	35.19	5.31	33.8	132	169	Peak
7386	47.04	-26.96	74	38.26	36.24	6.7	34.16	133	274	Peak

3.6 AC Conducted Emission Measurement

3.6.1 Limit of AC Conducted Emission

For equipment that is designed to be connected to the public utility (AC) power line, the radio frequency voltage that is conducted back onto the AC power line on any frequency or frequencies within the band 150 kHz to 30 MHz shall not exceed the limits in the following table.

Frequency of Emission (MHz)	Conducted Limit (dB μ V)	
	Quasi-Peak	Average
0.15-0.5	66 to 56*	56 to 46*
0.5-5	56	46
5-30	60	50

*Decreases with the logarithm of the frequency.

3.6.2 Measuring Instruments

The measuring equipment is listed in the section 4 of this test report.

3.6.3 Test Procedures

1. The EUT was placed 0.4 meter from the conducting wall of the shielding room, and it was kept at least 80 centimeters from any other grounded conducting surface.
2. Connect EUT to the power mains through a line impedance stabilization network (LISN).
3. All the support units are connecting to the other LISN.
4. The LISN provides 50 ohm coupling impedance for the measuring instrument.
5. The FCC states that a 50 ohm, 50 microhenry LISN should be used.
6. Both sides of AC line were checked for maximum conducted interference.
7. The frequency range from 150 kHz to 30 MHz was searched.
8. Set the test-receiver system to Peak Detect Function and specified bandwidth with Maximum Hold Mode.

3.6.4 Test Setup

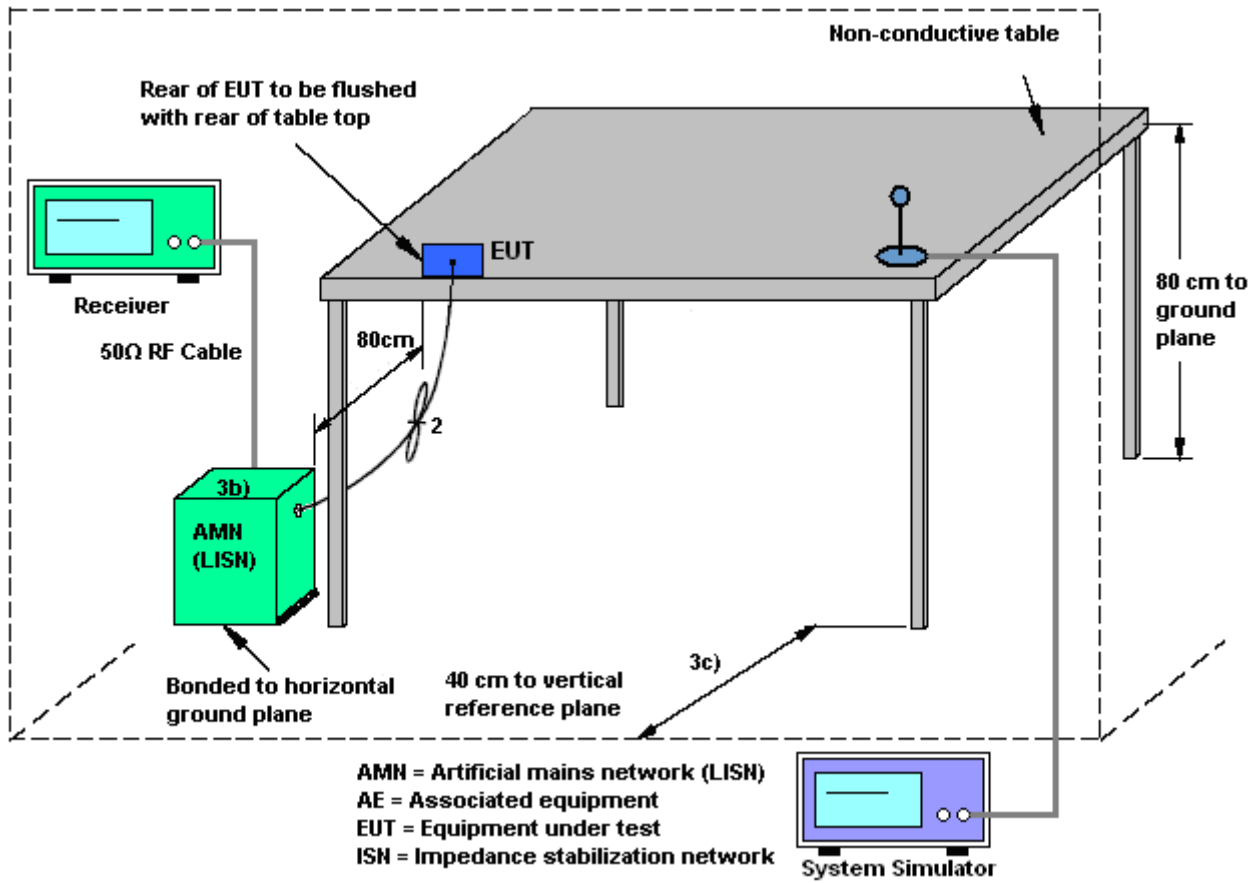



3.6.5 Test Result of AC Conducted Emission

Test Mode :	Mode 1	Temperature :	21~23°C
Test Engineer :	Eligah Wang	Relative Humidity :	37~39%
Test Voltage :	120Vac / 60Hz	Phase :	Line
Function Type :	GSM850 Idle + Bluetooth Link + WLAN Link + USB Cable (Charging from Adapter) + Earphone + NFC Tx		

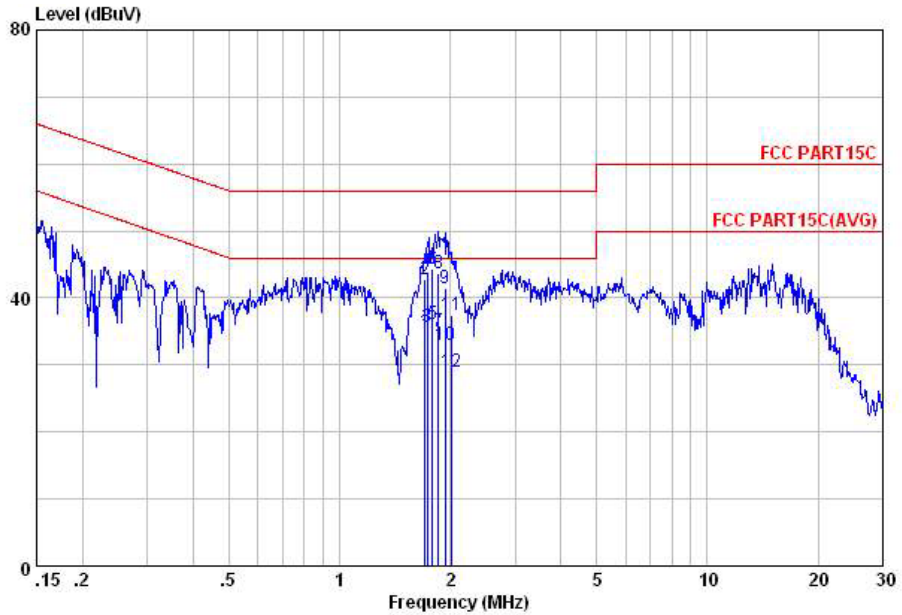

Site : C001-KS
 Condition: FCC PART15C LISN-L20130306 LINE

	Freq	Level	Over	Limit	Read	LISN	Cable	Remark
	MHz	dBuV	Limit	Line	Level	Factor	Loss	
			dB	dBuV	dBuV	dB	dB	
1	1.71	34.89	-11.11	46.00	24.60	0.10	10.19	Average
2	1.71	42.69	-13.31	56.00	32.40	0.10	10.19	QP
3	1.73	35.69	-10.31	46.00	25.40	0.10	10.19	Average
4	1.73	43.99	-12.01	56.00	33.70	0.10	10.19	QP
5	1.79	36.19	-9.81	46.00	25.90	0.10	10.19	Average
6	1.79	44.39	-11.61	56.00	34.10	0.10	10.19	QP
7	1.86	35.09	-10.91	46.00	24.80	0.10	10.19	Average
8	1.86	43.69	-12.31	56.00	33.40	0.10	10.19	QP
9	1.94	41.39	-14.61	56.00	31.10	0.10	10.19	QP
10	1.94	32.89	-13.11	46.00	22.60	0.10	10.19	Average
11	2.01	37.39	-18.61	56.00	27.10	0.10	10.19	QP
12	2.01	28.99	-17.01	46.00	18.70	0.10	10.19	Average



Test Mode :	Mode 1	Temperature :	21~23°C
Test Engineer :	Eligah Wang	Relative Humidity :	37~39%
Test Voltage :	120Vac / 60Hz	Phase :	Neutral
Function Type :	GSM850 Idle + Bluetooth Link + WLAN Link + USB Cable (Charging from Adapter) + Earphone + NFC Tx		

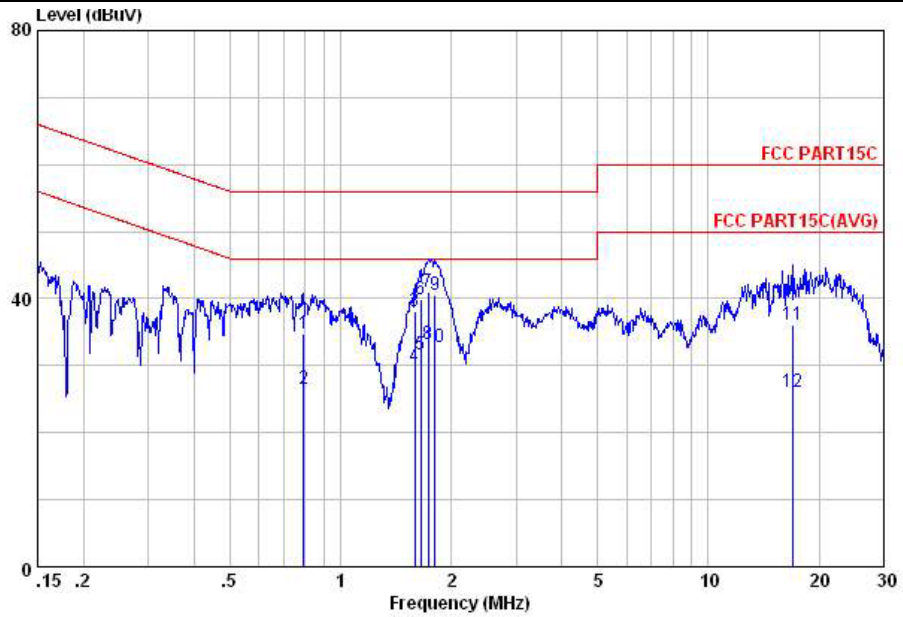

Site : C001-KS
 Condition: FCC PART15C LISN-N20130306 NEUTRAL

	Freq	Level	Over	Limit	Read	LISN	Cable	Remark
	MHz	dBuV	Limit	Line	Level	Factor	Loss	
			dB	dBuV	dBuV	dB	dB	
1	0.79	34.87	-21.13	56.00	24.50	0.17	10.20	QP
2	0.79	26.47	-19.53	46.00	16.10	0.17	10.20	Average
3	1.59	38.19	-17.81	56.00	27.90	0.10	10.19	QP
4	1.59	29.79	-16.21	46.00	19.50	0.10	10.19	Average
5	1.65	31.59	-14.41	46.00	21.30	0.10	10.19	Average
6	1.65	39.79	-16.21	56.00	29.50	0.10	10.19	QP
7	1.73	41.09	-14.91	56.00	30.80	0.10	10.19	QP
8	1.73	33.19	-12.81	46.00	22.90	0.10	10.19	Average
9	1.81	40.59	-15.41	56.00	30.30	0.10	10.19	QP
10	1.81	32.69	-13.31	46.00	22.40	0.10	10.19	Average
11	16.93	36.17	-23.83	60.00	25.60	0.26	10.31	QP
12	16.93	26.07	-23.93	50.00	15.50	0.26	10.31	Average



3.7 Antenna Requirements

3.7.1 Standard Applicable

If directional gain of transmitting antennas is greater than 6dBi, the power shall be reduced by the same level in dB comparing to gain minus 6dBi. For the fixed point-to-point operation, the power shall be reduced by one dB for every 3 dB that the directional gain of the antenna exceeds 6 dBi. The use of a permanently attached antenna or of an antenna that uses a unique coupling to the intentional radiator shall be considered sufficient to comply with the FCC rule.

3.7.2 Antenna Anti-Replacement Construction

An embedded-in antenna design is used.

3.7.3 Antenna Gain

The antenna peak gain of EUT is less than 6 dBi. Therefore, it is not necessary to reduce maximum peak output power limit.

4 List of Measuring Equipment

Instrument	Manufacturer	Model No.	Serial No.	Characteristics	Calibration Date	Test Date	Due Date	Remark
Spectrum Analyzer	R&S	FSP40	100319	9kHz~40GHz	Dec. 28, 2013	Apr. 04, 2014~ Apr. 25, 2014	Dec. 27, 2014	Conducted (TH01-KS)
Pulse Power Sensor	Anritsu	MA2411B	0917070	30MHz~40GHz	Feb. 27, 2014	Apr. 04, 2014~ Apr. 25, 2014	Feb. 26, 2015	Conducted (TH01-KS)
Power Meter	Anritsu	ML2495A	1005002	50MHz Bandwidth	Feb. 27, 2014	Apr. 04, 2014~ Apr. 25, 2014	Feb. 26, 2015	Conducted (TH01-KS)
EMI Test Receiver	R&S	ESCI	100534	9kHz~3GHz	Nov. 05, 2013	Apr. 09, 2014	Nov. 04, 2014	Radiation (03CH01-KS)
Spectrum Analyzer	R&S	FSP30	101399	9kHz~30GHz	May 23, 2013	Apr. 09, 2014	May 22, 2014	Radiation (03CH01-KS)
Loop Antenna	R&S	HFH2-Z2	100321	9kHz~30MHz	Oct. 09, 2013	Apr. 09, 2014	Oct. 08, 2014	Radiation (03CH01-KS)
Bilog Antenna	SCHAFFNER	CBL6112D	23182	25MHz~2GHz	Jan. 08, 2014	Apr. 09, 2014	Jan. 07, 2015	Radiation (03CH01-KS)
Double Ridge Horn Antenna	EMCO	3117	00075959	1GHz~18GHz	Jan. 08, 2014	Apr. 09, 2014	Jan. 07, 2015	Radiation (03CH01-KS)
SHF-EHF Horn	Schwarzbeck	BBHA 9170	BBHA1702 49	15GHz~40GHz	Mar. 10, 2014	Apr. 09, 2014	Mar. 09, 2015	Radiation (03CH01-KS)
Active Horn Antenna	com-power	AHA-118	701030	1GHz~18GHz	Nov. 18, 2013	Apr. 09, 2014	Nov. 17, 2014	Radiation (03CH01-KS)
Amplifier	com-power	PA-103A	161069	1MHz~1GHz	May 23, 2013	Apr. 09, 2014	May 22, 2014	Radiation (03CH01-KS)
Amplifier	Agilent	8449B	3008A023 71	1GHz~26.5GHz	Dec. 10, 2013	Apr. 09, 2014	Dec. 09, 2014	Radiation (03CH01-KS)
Turn Table	MF	MF7802	N/A	0~360 degree	NCR	Apr. 09, 2014	NCR	Radiation (03CH01-KS)
Antenna Mast	MF	MF7802	N/A	1 m~4 m	NCR	Apr. 09, 2014	NCR	Radiation (03CH01-KS)
EMI Receiver	R&S	ESCI7	100768	9kHz~7GHz	May 23, 2013	Mar. 31, 2014	May 22, 2014	Conduction (CO01-KS)
AC LISN	MessTec	AN3016	060103	9kHz~30MHz	Dec. 10, 2013	Mar. 31, 2014	Dec. 09, 2014	Conduction (CO01-KS)
AC LISN (for auxiliary equipment)	MessTec	AN3016	060105	9kHz~30MHz	Dec. 10, 2013	Mar. 31, 2014	Dec. 09, 2014	Conduction (CO01-KS)
AC Power Source	Chroma	61602	ABP00000 0811	AC 0V~300V, 45Hz~1000Hz	Nov. 12, 2013	Mar. 31, 2014	Nov. 11, 2014	Conduction (CO01-KS)



5 Uncertainty of Evaluation

Uncertainty of Conducted Emission Measurement (150kHz ~ 30MHz)

Measuring Uncertainty for a Level of Confidence of 95% ($U = 2Uc(y)$)	2.26
---	------

Uncertainty of Radiated Emission Measurement (30 MHz ~ 1000 MHz)

Measuring Uncertainty for a Level of Confidence of 95% ($U = 2Uc(y)$)	2.54
---	------