



FCC RF Test Report

APPLICANT : TCT Mobile Limited
EQUIPMENT : Module
BRAND NAME : ALCATEL
MODEL NAME : one touch M600Q
FCC ID : RAD425
STANDARD : FCC 47 CFR Part 2, 22(H), 24(E), 27(L)
CLASSIFICATION : PCS Licensed Transmitter (PCB)

The product was received on Jul. 19, 2013 and completely tested on Aug. 09, 2013. We, SPORTON INTERNATIONAL (SHENZHEN) INC., would like to declare that the tested sample has been evaluated in accordance with the procedures given in ANSI / TIA / EIA-603-C-2004 and shown compliance with the applicable technical standards.

The test results in this report apply exclusively to the tested model / sample. Without written approval of SPORTON INTERNATIONAL (SHENZHEN) INC., the test report shall not be reproduced except in full.

Reviewed by: Joseph Lin / Supervisor

Approved by: Jones Tsai / Manager



SPORTON INTERNATIONAL (SHENZHEN) INC.

No. 3 Building, the third floor of south, Shahe River west, Fengzeyuan warehouse, Nanshan District, Shenzhen, Guangdong, P.R.C.



TABLE OF CONTENTS

REVISION HISTORY..... 3

SUMMARY OF TEST RESULT 4

1 GENERAL DESCRIPTION 5

 1.1 Applicant..... 5

 1.2 Manufacturer 5

 1.3 Feature of Equipment Under Test..... 5

 1.4 Product Specification of Equipment Under Test 6

 1.5 Modification of EUT 6

 1.6 Maximum ERP/EIRP Power, Frequency Tolerance, and Emission Designator 7

 1.7 Testing Site 7

 1.8 Applied Standards 8

2 TEST CONFIGURATION OF EQUIPMENT UNDER TEST 9

 2.1 Test Mode..... 9

 2.2 Connection Diagram of Test System 11

 2.3 Support Unit used in test configuration and system..... 11

 2.4 Measurement Results Explanation Example 12

3 TEST RESULT..... 13

 3.1 Conducted Output Power Measurement..... 13

 3.2 Peak-to-Average Ratio 15

 3.3 Effective Radiated Power and Effective Isotropic Radiated Power Measurement 19

 3.4 Occupied Bandwidth and 26dB Bandwidth Measurement..... 24

 3.5 Band Edge Measurement..... 29

 3.6 Conducted Spurious Emission Measurement..... 32

 3.7 Field Strength of Spurious Radiation Measurement 36

 3.8 Frequency Stability Measurement..... 46

4 LIST OF MEASURING EQUIPMENT 49

5 UNCERTAINTY OF EVALUATION 50

APPENDIX A. SETUP PHOTOGRAPHS

APPENDIX B. PRODUCT EQUALITY DECLARATION



REVISION HISTORY

REPORT NO.	VERSION	DESCRIPTION	ISSUED DATE
FG342209-01	Rev. 01	This is report for one touch M600Q. The product equality declaration could be referred to Appendix B. All test cases were performed on original report which can be referred to SPORTON Report Number FG342209 (FCC ID: RAD383). Based on the original test report, only the Conducted Power, ERP/EIRP and worse case of Radiated Spurious Emissions for GPRS850, GPRS1900, WCDMA Band II and all full test items for WCDMA Band IV were verified.	Aug. 20, 2013



SUMMARY OF TEST RESULT

Report Section	FCC Rule	Description	Limit	Result	Remark
3.1	§2.1046	Conducted Output Power	Reporting Only	PASS	-
3.2	§24.232(d) §27.50(d)(5)	Peak-to-Average Ratio	< 13 dB	PASS	-
3.3	§22.913(a)(2)	Effective Radiated Power	< 7 Watts	PASS	-
3.3	§24.232(c)	Equivalent Isotropic Radiated Power	< 2 Watts	PASS	-
3.3	§27.50(d)(4)	Equivalent Isotropic Radiated Power	< 1 Watts	PASS	-
3.4	§2.1049 §22.917(a) §24.238(b) §27.53(g)	99% Occupied Bandwidth and 26dB Bandwidth	Reporting Only	PASS	-
3.5	§2.1051 §22.917(a) §24.238(a) §27.53(g)	Band Edge Measurement	< 43+10log10(P[Watts])	PASS	-
3.6	§2.1051 §22.917(a) §24.238(a) §27.53(g)	Conducted Spurious Emission	< 43+10log10(P[Watts])	PASS	-
3.7	§2.1053 §22.917(a) §24.238(a) §27.53(g)	Field Strength of Spurious Radiation	< 43+10log10(P[Watts])	PASS	Under limit 7.87 dB at 11280.000 MHz
3.8	§2.1055 §22.355 §24.235 §27.54	Frequency Stability for Temperature & Voltage	< 2.5 ppm	PASS	-



1 General Description

1.1 Applicant

TCT Mobile Limited

5F, C building, No. 232, Liang Jing Road ZhangJiang High-Tech Park, Pudong Area Shanghai, P.R. China.
201203

1.2 Manufacturer

TCL COMMUNICATION TECHNOLOGY HOLDINGS LIMITED

70 Huifeng 4rd., ZhongKai Hi-tech Development District, Huizhou, Guangdong 516006 P.R.China (TCL Mobile Communication Co., LTD. Huizhou)

1.3 Feature of Equipment Under Test

Product Feature	
Equipment	Module
Brand Name	ALCATEL
Model Name	one touch M600Q
FCC ID	RAD425
EUT supports Radios application	GPRS/EGPRS/WCDMA/HSPA/HSPA+ (Downlink Only)
HW Version	V4.0
SW Version	ZX120200XX
EUT Stage	Production Unit

Remark: The above EUT's information was declared by manufacturer. Please refer to the specifications or user's manual for more detailed description.

1.4 Product Specification of Equipment Under Test

Product Specification subjective to this standard	
Tx Frequency	GPRS850: 824.2 MHz ~ 848.8 MHz GPRS1900: 1850.2 MHz ~ 1909.8MHz WCDMA Band IV : 1712.4 MHz ~ 1752.6 MHz WCDMA Band II: 1852.4 MHz ~ 1907.6 MHz
Rx Frequency	GPRS850: 869.2 MHz ~ 893.8 MHz GPRS1900: 1930.2 MHz ~ 1989.8 MHz WCDMA Band IV : 2112.4 MHz ~ 2152.6 MHz WCDMA Band II : 1932.4 MHz ~ 1987.6 MHz
Maximum Output Power to Antenna	GPRS850 : 32.43 dBm GPRS1900 : 29.40 dBm WCDMA Band IV : 22.26 dBm WCDMA Band II : 21.73 dBm
Antenna Type	Monopole Antenna
Antenna Gain	GPRS850 : -3.1 dBi GPRS1900 : -2.8 dBi WCDMA Band IV : -2.6 dBi WCDMA Band II : -2.8 dBi
Type of Modulation	GPRS: GMSK EDGE: GMSK / 8PSK WCDMA: QPSK (Uplink) HSDPA: QPSK (Uplink) HSUPA: QPSK (Uplink) HSPA+: 16QAM (Downlink Only)

1.5 Modification of EUT

No modifications are made to the EUT during all test items.

1.6 Maximum ERP/EIRP Power, Frequency Tolerance, and Emission Designator

FCC Rule	System	Type of Modulation	Maximum ERP/EIRP (W)	Frequency Tolerance (% , Hz, ppm)	Emission Designator
Part 22	GPRS850 GPRS class 8	GMSK	1.7655	-	-
Part 22	GPRS850 EDGE class 8	8PSK	0.4123	-	-
Part 24	GPRS1900 GPRS class 8	GMSK	1.3661	-	-
Part 24	GPRS1900 EDGE class 8	8PSK	0.5076	-	-
Part 24	WCDMA Band II RMC 12.2Kbps	QPSK	0.2321	-	-
Part 27	WCDMA Band IV RMC 12.2Kbps	QPSK	0.2070	0.01 ppm	4M20F9W

1.7 Testing Site

Test Site	SPORTON INTERNATIONAL (SHENZHEN) INC.				
Test Site Location	No. 3 Building, the third floor of south, Shahe River west, Fengzeyuan warehouse, Nanshan District, Shenzhen, Guangdong, P.R.C. TEL: +86-755- 3320-2398				
Test Site No.	Sporton Site No.			FCC/IC Registration No.	
	TH01-SZ	03CH01-SZ	OTA01-SZ	831040/4086F-1	



1.8 Applied Standards

According to the specifications of the manufacturer, the EUT must comply with the requirements of the following standards:

- ♦ 47 CFR Part 2, 22(H), 24(E), 27(L)
- ♦ ANSI / TIA / EIA-603-C-2004
- ♦ FCC KDB 971168 D01 Power Meas. License Digital Systems v02r01

Remark:

1. All test items were verified and recorded according to the standards and without any deviation during the test.
2. This EUT has also been tested and complied with the requirements of FCC Part 15, Subpart B, recorded in a separate test report.

2 Test Configuration of Equipment Under Test

2.1 Test Mode

During all testing, EUT is in link mode with base station emulator at maximum power level. The spurious emission measurements were carried out in semi-anechoic chamber with 3-meter test range.

Frequency range investigated for radiated emission is as follows:

1. 30 MHz to 9000 MHz for GPRS850.
2. 30 MHz to 18000 MHz for WCDMA Band IV.
3. 30 MHz to 19000 MHz for GPRS1900 and WCDMA Band II.

Test Modes		
Band	Radiated TCs	Conducted TCs
GPRS 850	<ul style="list-style-type: none"> ■ GPRS class 8 Link 	<ul style="list-style-type: none"> ■ GPRS class 8 Link ■ EDGE class 8 Link
GPRS 1900	<ul style="list-style-type: none"> ■ GPRS class 8 Link 	<ul style="list-style-type: none"> ■ GPRS class 8 Link ■ EDGE class 8 Link
WCDMA Band IV	<ul style="list-style-type: none"> ■ RMC 12.2Kbps Link 	<ul style="list-style-type: none"> ■ RMC 12.2Kbps Link
WCDMA Band II	<ul style="list-style-type: none"> ■ RMC 12.2Kbps Link 	<ul style="list-style-type: none"> ■ RMC 12.2Kbps Link

Note: The maximum power levels are GPRS multi-slot class 8 mode for GMSK link, EDGE multi-slot class 8 mode for 8PSK link, RMC 12.2Kbps mode for WCDMA band II, and RMC 12.2Kbps mode for WCDMA band IV, only these modes were used for all tests.



The conducted power tables are as follows:

Conducted Power (*Unit: dBm)						
Band	GPRS850			GPRS1900		
Channel	128	189	251	512	661	810
Frequency	824.2	836.4	848.8	1850.2	1880.0	1909.8
GPRS (GMSK, 1 Tx slot) – CS1	32.26	32.31	32.43	29.20	29.17	29.40
GPRS (GMSK, 2 Tx slots) – CS1	27.68	27.73	27.82	26.31	26.30	26.38
GPRS (GMSK, 3 Tx slots) – CS1	25.71	25.77	25.86	24.30	24.30	24.38
GPRS (GMSK, 4 Tx slots) – CS1	24.71	24.76	24.86	23.31	23.30	23.39
EDGE (GMSK, 1 Tx slot) – MCS1	32.24	32.30	32.41	29.20	29.16	29.25
EDGE (GMSK, 2 Tx slots) – MCS1	27.67	27.71	27.80	26.34	26.27	26.38
EDGE (GMSK, 3 Tx slots) – MCS1	25.72	25.76	25.87	24.34	24.27	24.39
EDGE (GMSK, 4 Tx slots) – MCS1	24.68	24.74	24.84	23.33	23.30	23.38
EDGE (8PSK, 1 Tx slot) – MCS5	25.69	25.70	25.81	25.27	25.23	25.34
EDGE (8PSK, 2 Tx slots) – MCS5	22.84	22.85	22.95	22.40	22.36	22.47
EDGE (8PSK, 3 Tx slots) – MCS5	21.86	21.86	21.95	21.41	21.37	21.48
EDGE (8PSK, 4 Tx slots) – MCS5	19.90	19.90	19.99	19.40	19.39	19.51

Conducted Power (*Unit: dBm)						
Band	WCDMA Band II			WCDMA Band IV		
Channel	9262	9400	9538	1312	1413	1513
Frequency	1852.4	1880	1907.6	1712.4	1732.6	1752.6
RMC 12.2Kbps	21.62	21.73	21.64	21.80	22.26	21.75
HSDPA Subtest-1	20.86	20.98	20.82	21.26	21.59	21.06
HSDPA Subtest-2	20.97	21.12	20.85	21.13	21.55	21.03
HSDPA Subtest-3	21.02	21.15	20.94	21.09	21.47	21.01
HSDPA Subtest-4	20.95	21.13	20.82	21.07	21.54	20.98
HSUPA Subtest-1	20.05	20.23	19.82	20.11	20.45	20.18
HSUPA Subtest-2	18.69	18.73	18.49	18.97	19.35	19.01
HSUPA Subtest-3	19.81	19.68	19.49	19.86	20.07	19.99
HSUPA Subtest-4	18.72	19.13	19.43	19.26	19.98	19.91
HSUPA Subtest-5	20.43	20.40	20.25	20.43	20.75	20.56

2.2 Connection Diagram of Test System

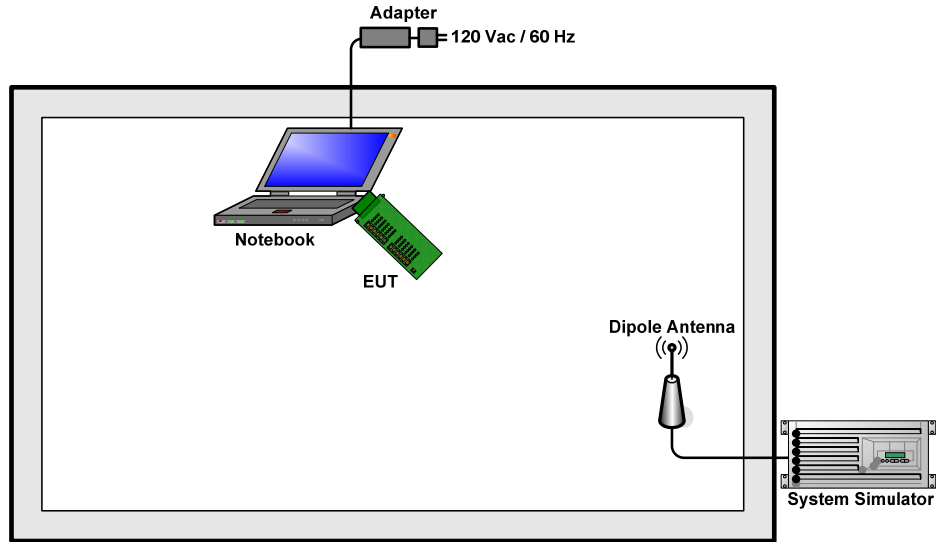

2.3 Support Unit used in test configuration and system

Item	Equipment	Trade Name	Model No.	FCC ID	Data Cable	Power Cord
1.	System Simulator	Agilent	E5515C	N/A	N/A	Unshielded, 1.8 m
2.	System Simulator	R&S	CMU 200	N/A	N/A	Unshielded, 1.8 m
3.	Notebook	Lenovo	G480	PPD-AR5B195	N/A	AC I/P: Unshielded, 1.8 m DC O/P: Shielded, 1.8 m
4.	DC Power Supply	TOPWORD	3303DR	N/A	N/A	Unshielded, 1.8 m



2.4 Measurement Results Explanation Example

For all conducted test items:

The offset level is set in the spectrum analyzer to compensate the RF cable loss and attenuator factor between EUT conducted output port and spectrum analyzer. With the offset compensation, the spectrum analyzer reading level is exactly the EUT RF output level.

The spectrum analyzer offset is derived from RF cable loss and attenuator factor.

Offset = RF cable loss + attenuator factor.

Following shows an offset computation example with cable loss 4.2 dB and 10dB attenuator.

Example :

$$\begin{aligned} \text{Offset(dB)} &= \text{RF cable loss(dB)} + \text{attenuator factor(dB)}. \\ &= 4.2 + 10 = 14.2 \text{ (dB)} \end{aligned}$$

3 Test Result

3.1 Conducted Output Power Measurement

3.1.1 Description of the Conducted Output Power

A base station simulator was used to establish communication with the EUT. Its parameters were set to transmit the maximum power on the EUT. The measured power in the radio frequency on the transmitter output terminals shall be reported.

3.1.2 Measuring Instruments

See list of measuring instruments of this test report.

3.1.3 Test Procedures

1. The transmitter output port was connected to base station.
2. The RF output of EUT was connected to the spectrum analyzer by RF cable and attenuator. The path loss was compensated to the results for each measurement.
3. Set EUT at maximum power through base station.
4. Select lowest, middle, and highest channels for each band and different modulation.
5. Measure the maximum burst average power for GPRS and maximum average power for GPRS and WCDMA modes.

3.1.4 Test Setup

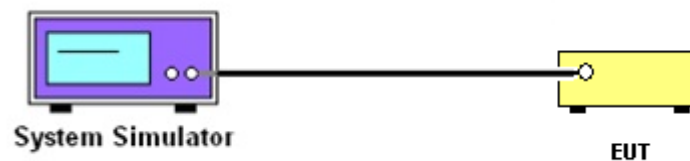

3.1.5 Test Result of Conducted Output Power

Cellular Band						
Modes	GPRS850 (GPRS class 8)			GPRS850 (EDGE class 8)		
Channel	128 (Low)	189 (Mid)	251 (High)	128 (Low)	189 (Mid)	251 (High)
Frequency (MHz)	824.2	836.4	848.8	824.2	836.4	848.8
Conducted Power (dBm)	32.26	32.31	32.43	25.69	25.70	25.81
Conducted Power (Watts)	1.68	1.70	1.75	0.37	0.37	0.38

PCS Band									
Modes	GPRS1900 (GPRS class 8)			GPRS1900 (EDGE class 8)			WCDMA Band II (RMC 12.2Kbps)		
Channel	512 (Low)	661 (Mid)	810 (High)	512 (Low)	661 (Mid)	810 (High)	9262 (Low)	9400 (Mid)	9538 (High)
Frequency (MHz)	1850.2	1880	1909.8	1850.2	1880	1909.8	1852.4	1880	1907.6
Conducted Power (dBm)	29.20	29.17	29.40	25.27	25.23	25.34	21.62	21.73	21.64
Conducted Power (Watts)	0.83	0.83	0.87	0.34	0.33	0.34	0.15	0.15	0.15

AWS Band			
Modes	WCDMA Band IV (RMC 12.2Kbps)		
Channel	1312(Low)	1413 (Mid)	1513 (High)
Frequency (MHz)	1712.4	1732.6	1752.6
Conducted Power (dBm)	21.80	22.26	21.75
Conducted Power (Watts)	0.15	0.17	0.15

Note: maximum burst average power for GPRS, and maximum average power for WCDMA.

3.2 Peak-to-Average Ratio

3.2.1 Description of the PAR Measurement

The peak-to-average ratio (PAR) of the transmission may not exceed 13 dB.

3.2.2 Measuring Instruments

See list of measuring instruments of this test report.

3.2.3 Test Procedures

1. The EUT was connected to Spectrum Analyzer and System Simulator via power divider.
2. For UMTS operating modes:
 - a. Set the CCDF (Complementary Cumulative Distribution Function) option in spectrum analyzer.
 - b. The highest RF powers were measured and recorded the maximum PAPR level associated with a probability of 0.1 %.
3. Record the deviation as Peak to Average Ratio.

3.2.4 Test Setup

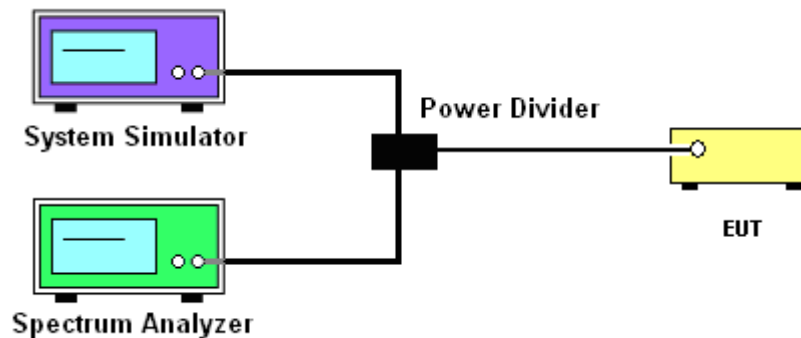



3.2.5 Test Result of Peak-to-Average Ratio

AWS Band			
Modes	WCDMA Band IV (RMC 12.2Kbps)		
Channel	1312(Low)	1413 (Mid)	1513 (High)
Frequency (MHz)	1712.4	1732.6	1752.6
Peak-to-Average Ratio (dB)	3.28	3.40	3.28



3.2.6 Test Result (Plots) of Peak-to-Average Ratio

Band :	WCDMA Band IV	Test Mode :	RMC 12.2Kbps Link (QPSK)
--------	---------------	-------------	--------------------------

Peak-to-Average Ratio on Channel 1312 (1712.4 MHz)

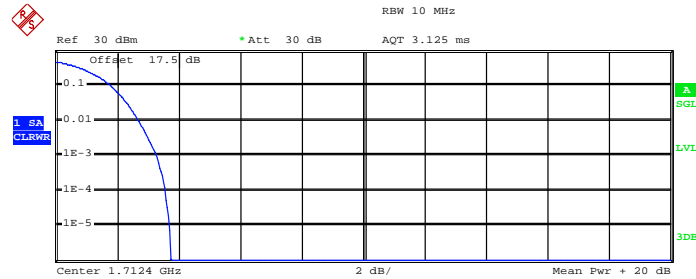

Complementary Cumulative Distribution Function (100000 samples)

Trace 1

Mean	21.15 dBm
Peak	24.89 dBm
Crest	3.74 dB
10 %	1.80 dB
1 %	2.72 dB
.1 %	3.28 dB
.01 %	3.56 dB

Date: 9.AUG.2013 15:26:19

Peak-to-Average Ratio on Channel 1413 (1732.6 MHz)

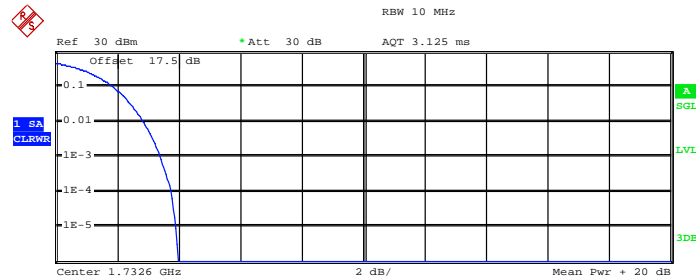

Complementary Cumulative Distribution Function (100000 samples)

Trace 1

Mean	21.34 dBm
Peak	25.31 dBm
Crest	3.98 dB
10 %	1.88 dB
1 %	2.88 dB
.1 %	3.40 dB
.01 %	3.76 dB

Date: 9.AUG.2013 15:25:41



Peak-to-Average Ratio on Channel 1513 (1752.6 MHz)

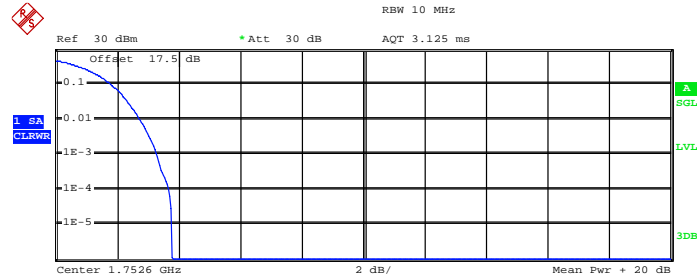

Complementary Cumulative Distribution Function (100000 samples)

Trace 1

Mean	21.09 dBm
Peak	24.89 dBm
Crest	3.79 dB
10 %	1.80 dB
1 %	2.76 dB
.1 %	3.28 dB
.01 %	3.68 dB

Date: 9.AUG.2013 15:26:59



3.3 Effective Radiated Power and Effective Isotropic Radiated Power Measurement

3.3.1 Description of the ERP/EIRP Measurement

The substitution method, in ANSI / TIA / EIA-603-C-2004, was used for ERP/EIRP measurement, and the spectrum analyzer configuration follows KDB 971168 D01 Power Meas. License Digital Systems v02. The ERP of mobile transmitters must not exceed 7 Watts and the EIRP of mobile transmitters are limited to 2 Watts.

3.3.2 Measuring Instruments

See list of measuring instruments of this test report.

3.3.3 Test Procedures

1. The EUT was placed on a turntable with 1.5 meter height in a fully anechoic chamber.
2. The EUT was set at 3 meters from the receiving antenna, which was mounted on the antenna tower.
3. GPRS operating modes: Set RBW= 1MHz, VBW= 3MHz, RMS detector over burst;
UMTS operating modes: Set RBW= 100 kHz, VBW= 300 kHz, RMS detector over frame, and use channel power option with bandwidth=5MHz, per section 4.0 of KDB 971168 D01.
4. The table was rotated 360 degrees to determine the position of the highest radiated power.
5. The height of the receiving antenna is adjusted to look for the maximum ERP/EIRP.
6. Taking the record of maximum ERP/EIRP.
7. A dipole antenna was substituted in place of the EUT and was driven by a signal generator.
8. The conducted power at the terminal of the dipole antenna is measured.
9. Repeat step 3 to step 5 to get the maximum ERP/EIRP of the substitution antenna.
10. $ERP/EIRP = P_s + E_t - E_s + G_s = P_s + R_t - R_s + G_s$

P_s (dBm) : Input power to substitution antenna.

G_s (dBi or dBd) : Substitution antenna Gain.

$E_t = R_t + AF$

$E_s = R_s + AF$

AF (dB/m) : Receive antenna factor

R_t : The highest received signal in spectrum analyzer for EUT.

R_s : The highest received signal in spectrum analyzer for substitution antenna.

3.3.4 Test Setup

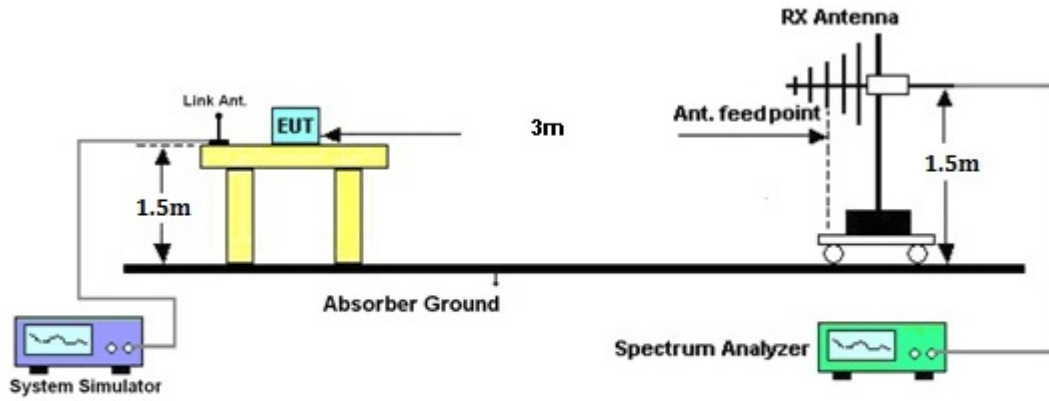



3.3.5 Test Result of ERP

GPRS850 (GPRS class 8) Radiated Power ERP						
Horizontal Polarization						
Frequency (MHz)	Rt (dBm)	Rs (dBm)	Ps (dBm)	Gs (dBd)	ERP (dBm)	ERP (W)
824.20	-15.71	-48.12	0.00	-1.08	31.33	1.3573
836.40	-15.01	-48.28	0.00	-0.93	32.34	1.7146
848.80	-15.12	-48.35	0.00	-0.76	32.47	1.7655
Vertical Polarization						
Frequency (MHz)	Rt (dBm)	Rs (dBm)	Ps (dBm)	Gs (dBd)	ERP (dBm)	ERP (W)
824.20	-16.11	-47.97	0.00	-1.08	30.78	1.1975
836.40	-15.30	-48.01	0.00	-0.93	31.78	1.5054
848.80	-15.39	-48.05	0.00	-0.76	31.90	1.5472

GPRS850 (EDGE class 8) Radiated Power ERP						
Horizontal Polarization						
Frequency (MHz)	Rt (dBm)	Rs (dBm)	Ps (dBm)	Gs (dBd)	ERP (dBm)	ERP (W)
824.20	-21.85	-48.12	0.00	-1.08	25.19	0.3302
836.40	-21.41	-48.28	0.00	-0.93	25.94	0.3923
848.80	-21.44	-48.35	0.00	-0.76	26.15	0.4123
Vertical Polarization						
Frequency (MHz)	Rt (dBm)	Rs (dBm)	Ps (dBm)	Gs (dBd)	ERP (dBm)	ERP (W)
824.20	-22.37	-47.97	0.00	-1.08	24.52	0.2832
836.40	-21.36	-48.01	0.00	-0.93	25.72	0.3733
848.80	-21.61	-48.05	0.00	-0.76	25.68	0.3701



3.3.6 Test Result of EIRP

GPRS1900 (GPRS class 8) Radiated Power EIRP						
Horizontal Polarization						
Frequency (MHz)	Rt (dBm)	Rs (dBm)	Ps (dBm)	Gs (dBi)	EIRP (dBm)	EIRP (W)
1850.20	-26.29	-51.88	0.00	1.96	27.55	0.5687
1880.00	-26.99	-52.99	0.00	2.00	28.00	0.6313
1909.80	-28.24	-54.28	0.00	1.98	28.02	0.6336
Vertical Polarization						
Frequency (MHz)	Rt (dBm)	Rs (dBm)	Ps (dBm)	Gs (dBi)	EIRP (dBm)	EIRP (W)
1850.20	-24.07	-52.13	0.00	1.96	30.02	1.0042
1880.00	-24.30	-53.17	0.00	2.00	30.87	1.2229
1909.80	-24.76	-54.13	0.00	1.98	31.35	1.3661

GPRS1900 (EDGE class 8) Radiated Power EIRP						
Horizontal Polarization						
Frequency (MHz)	Rt (dBm)	Rs (dBm)	Ps (dBm)	Gs (dBi)	EIRP (dBm)	EIRP (W)
1850.20	-29.80	-51.88	0.00	1.96	24.04	0.2533
1880.00	-30.97	-52.99	0.00	2.00	24.02	0.2522
1909.80	-32.46	-54.28	0.00	1.98	23.80	0.2401
Vertical Polarization						
Frequency (MHz)	Rt (dBm)	Rs (dBm)	Ps (dBm)	Gs (dBi)	EIRP (dBm)	EIRP (W)
1850.20	-27.87	-52.13	0.00	1.96	26.22	0.4191
1880.00	-28.24	-53.17	0.00	2.00	26.93	0.4934
1909.80	-29.05	-54.13	0.00	1.98	27.06	0.5076



WCDMA Band IV (RMC 12.2Kbps) Radiated Power EIRP						
Horizontal Polarization						
Frequency (MHz)	Rt (dBm)	Rs (dBm)	Ps (dBm)	Gs (dBi)	EIRP (dBm)	EIRP (W)
1712.40	-32.55	-51.88	0.00	1.96	21.29	0.1346
1732.60	-32.74	-52.99	0.00	2.00	22.25	0.1679
1752.60	-35.14	-54.28	0.00	1.98	21.12	0.1294
Vertical Polarization						
Frequency (MHz)	Rt (dBm)	Rs (dBm)	Ps (dBm)	Gs (dBi)	EIRP (dBm)	EIRP (W)
1712.40	-31.75	-52.13	0.00	1.96	22.34	0.1714
1732.60	-32.01	-53.17	0.00	2.00	23.16	0.2070
1752.60	-34.09	-54.13	0.00	1.98	22.02	0.1592

WCDMA Band II (RMC 12.2Kbps) Radiated Power EIRP						
Horizontal Polarization						
Frequency (MHz)	Rt (dBm)	Rs (dBm)	Ps (dBm)	Gs (dBi)	EIRP (dBm)	EIRP (W)
1852.40	-34.08	-51.88	0.00	1.96	19.76	0.0947
1880.00	-33.91	-52.99	0.00	2.00	21.08	0.1281
1907.60	-35.42	-54.28	0.00	1.98	20.84	0.1213
Vertical Polarization						
Frequency (MHz)	Rt (dBm)	Rs (dBm)	Ps (dBm)	Gs (dBi)	EIRP (dBm)	EIRP (W)
1852.40	-32.04	-52.13	0.00	1.96	22.05	0.1602
1880.00	-31.51	-53.17	0.00	2.00	23.66	0.2321
1907.60	-32.79	-54.13	0.00	1.98	23.32	0.2149

3.4 Occupied Bandwidth and 26dB Bandwidth Measurement

3.4.1 Description of Occupied Bandwidth and 26dB Bandwidth Measurement

The occupied bandwidth is the width of a frequency band such that, below the lower and above the upper frequency limits, the mean powers emitted are each equal to a specified percentage 0.5% of the total mean transmitted power.

The emission bandwidth is defined as the width of the signal between two points, located at the 2 sides of the carrier frequency, outside of which all emissions are attenuated at least 26 dB below the transmitter power.

3.4.2 Measuring Instruments

See list of measuring instruments of this test report.

3.4.3 Test Procedures

1. The EUT was connected to Spectrum Analyzer and Base Station via power divider.
2. The RF output of EUT was connected to the spectrum analyzer by RF cable and attenuator. The path loss was compensated to the results for each measurement.
3. The 99% occupied bandwidth were measured, set RBW= 1% of span, VBW= 3*RBW, sample detector, trace maximum hold.
4. The 26dB bandwidth were measured, set RBW= 1% of EBW, VBW= 3*RBW, peak detector, trace maximum hold.

3.4.4 Test Setup

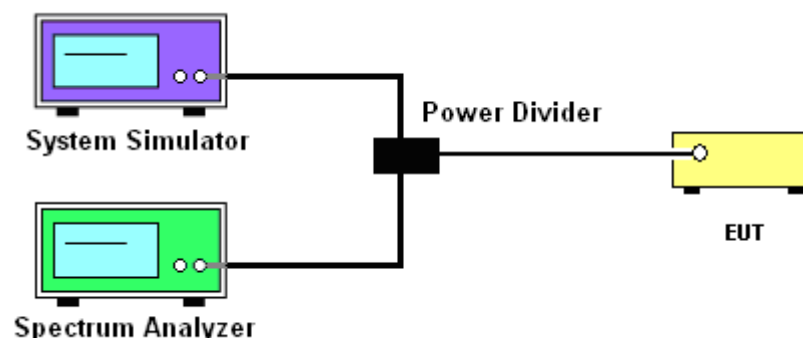



3.4.5 Test Result of Occupied Bandwidth and 26dB Bandwidth

AWS Band			
Modes	WCDMA Band IV (RMC 12.2Kbps)		
Channel	1312(Low)	1413 (Mid)	1513 (High)
Frequency (MHz)	1712.4	1732.6	1752.6
99% OBW (MHz)	4.20	4.18	4.18
26dB BW (MHz)	4.70	4.68	4.68



3.4.6 Test Result (Plots) of Occupied Bandwidth and 26dB Bandwidth

Band :	WCDMA Band IV	Test Mode :	RMC 12.2Kbps Link (QPSK)
--------	---------------	-------------	--------------------------

99% Occupied Bandwidth Plot on Channel 1312 (1712.4 MHz)

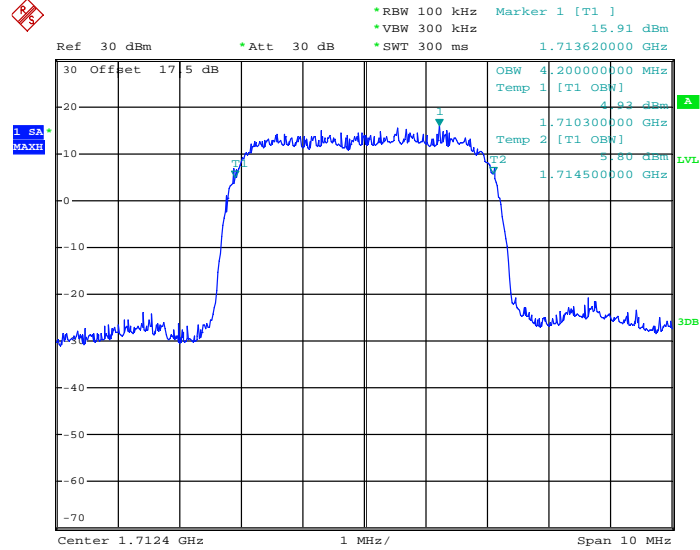

Date: 9.AUG.2013 15:23:50

26dB Bandwidth Plot on Channel 1312 (1712.4 MHz)

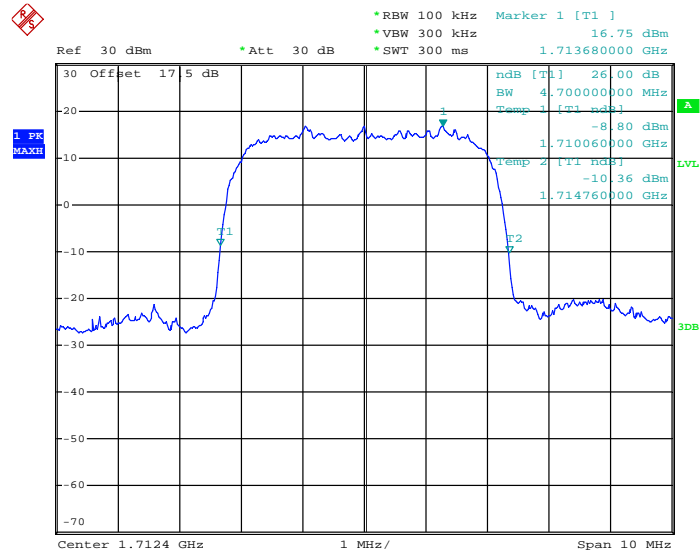

Date: 9.AUG.2013 15:20:17



99% Occupied Bandwidth Plot on Channel 1413 (1732.6 MHz)

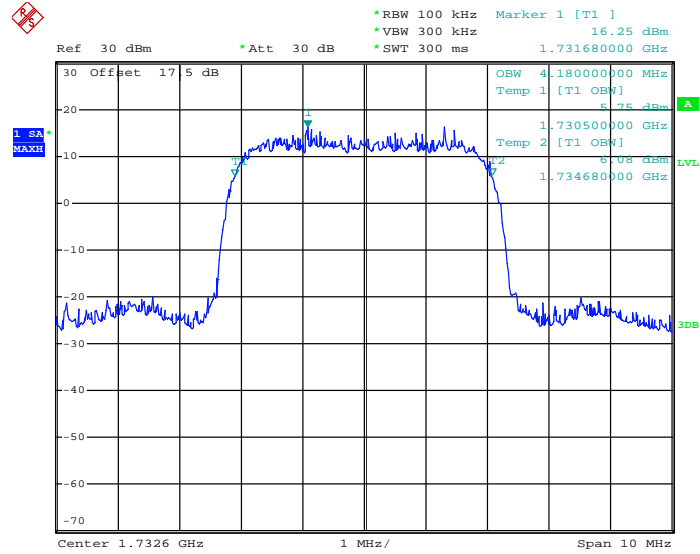

Date: 9.AUG.2013 15:24:46

26dB Bandwidth Plot on Channel 1413 (1732.6 MHz)

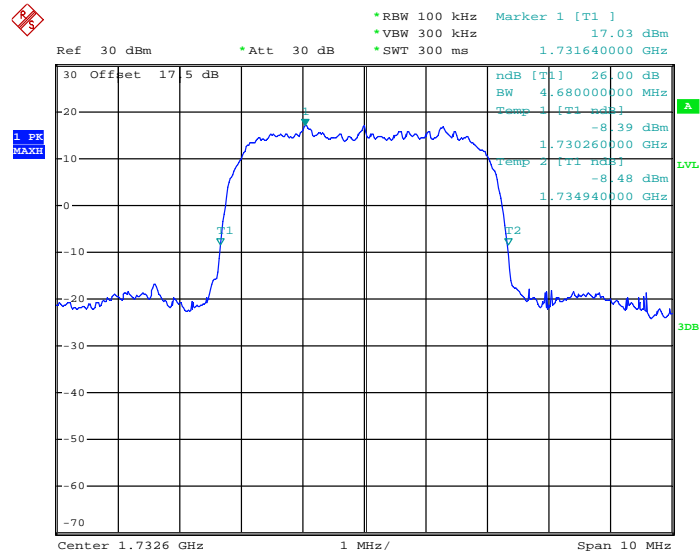

Date: 9.AUG.2013 15:19:02



99% Occupied Bandwidth Plot on Channel 1513 (1752.6 MHz)

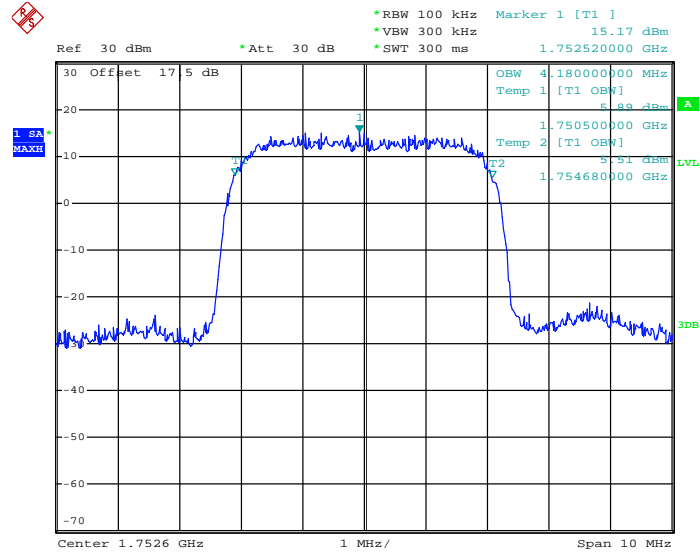

Date: 9.AUG.2013 15:22:32

26dB Bandwidth Plot on Channel 1513 (1752.6 MHz)

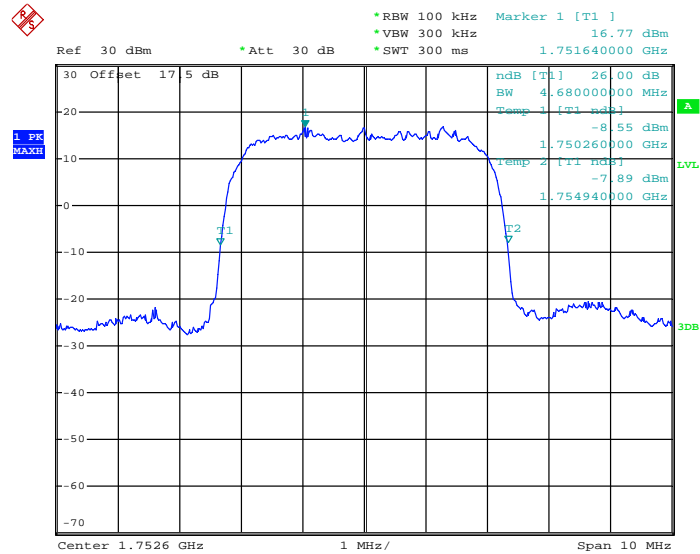

Date: 9.AUG.2013 15:21:05

3.5 Band Edge Measurement

3.5.1 Description of Band Edge Measurement

The power of any emission outside of the authorized operating frequency ranges must be lower than the transmitter power (P) by a factor of at least $43 + 10 \log (P)$ dB.

3.5.2 Measuring Instruments

See list of measuring instruments of this test report.

3.5.3 Test Procedures

1. The EUT was connected to Spectrum Analyzer and Base Station via power divider.
2. The RF output of EUT was connected to the spectrum analyzer by RF cable and attenuator. The path loss was compensated to the results for each measurement.
3. The band edges of low and high channels for the highest RF powers were measured. Setting RBW as roughly $BW/100$.
4. The RF fundamental frequency should be excluded against the limit line in the operating frequency band.
5. The limit line is derived from $43 + 10\log(P)$ dB below the transmitter power P(Watts)
 $= P(W) - [43 + 10\log(P)]$ (dB)
 $= [30 + 10\log(P)]$ (dBm) - $[43 + 10\log(P)]$ (dB)
 $= -13\text{dBm}$.

3.5.4 Test Setup

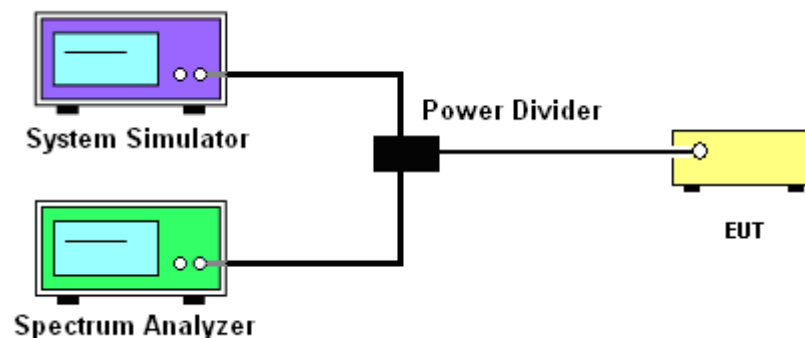



3.5.5 Test Result (Plots) of Conducted Band Edge

Band :	WCDMA Band IV	Test Mode :	RMC 12.2Kbps Link (QPSK)
Correction Factor :	-3.28dB	Maximum 26dB Bandwidth :	4.70MHz
Band Edge :	-30.87dBm	Measurement Value :	-27.59dBm

Lower Band Edge Plot on Channel 1312 (1712.4 MHz)

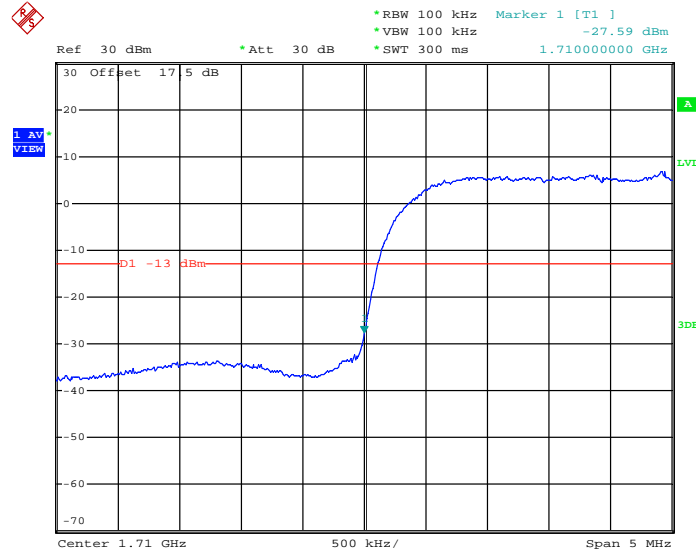

Date: 9.AUG.2013 15:31:42

1. Correction Factor(dB)= $10\log(1\% \text{ Emission BW/RBW})$
2. Band Edge= Measurement Value + Correction Factor(dB)



Band :	WCDMA Band IV	Test Mode :	RMC 12.2Kbps Link (QPSK)
Correction Factor :	-3.28dB	Maximum 26dB Bandwidth :	4.70MHz
Band Edge :	-30.26dBm	Measurement Value :	-26.98dBm

Higher Band Edge Plot on Channel 1513 (1752.6 MHz)

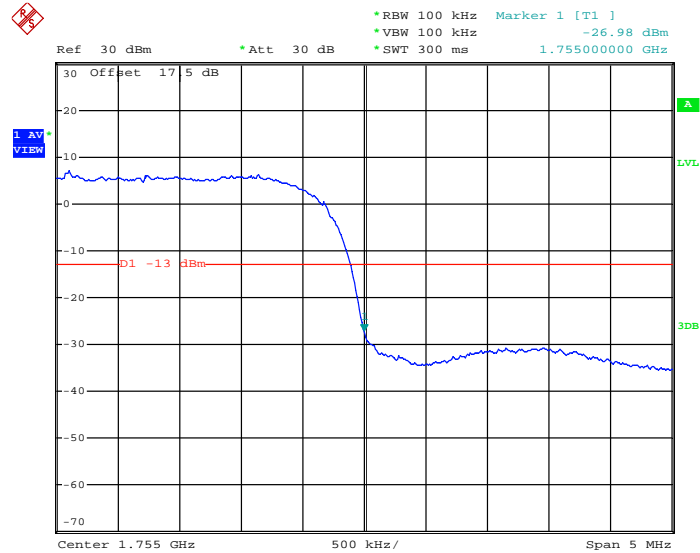

Date: 9.AUG.2013 15:31:08

1. Correction Factor(dB)= 10log(1% Emission BW/RBW)
2. Band Edge= Measurement Value + Correction Factor(dB)

3.6 Conducted Spurious Emission Measurement

3.6.1 Description of Conducted Spurious Emission Measurement

The power of any emission outside of the authorized operating frequency ranges must be lower than the transmitter power (P) by a factor of at least $43 + 10 \log (P)$ dB.

It is measured by means of a calibrated spectrum analyzer and scanned from 30 MHz up to a frequency including its 10th harmonic.

3.6.2 Measuring Instruments

See list of measuring instruments of this test report.

3.6.3 Test Procedures

1. The EUT was connected to spectrum analyzer and base station via power divider.
2. The RF output of EUT was connected to the spectrum analyzer by RF cable and attenuator. The path loss was compensated to the results for each measurement.
3. The middle channel for the highest RF power within the transmitting frequency was measured.
4. The conducted spurious emission for the whole frequency range was taken.
5. The RF fundamental frequency should be excluded against the limit line in the operating frequency band.
6. The limit line is derived from $43 + 10\log(P)$ dB below the transmitter power P(Watts)

$$= P(W) - [43 + 10\log(P)] \text{ (dB)}$$

$$= [30 + 10\log(P)] \text{ (dBm)} - [43 + 10\log(P)] \text{ (dB)}$$

$$= -13\text{dBm}.$$

3.6.4 Test Setup

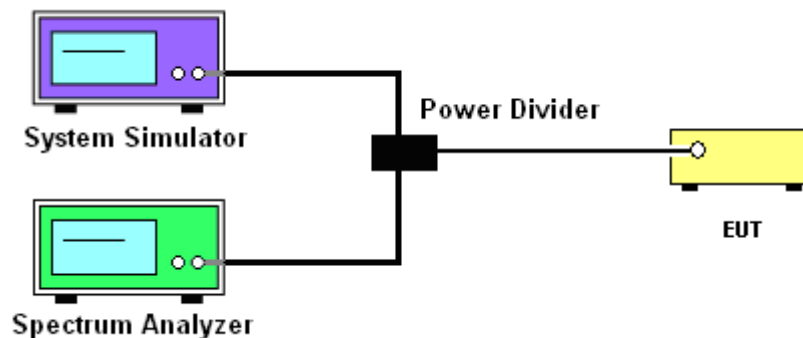



3.6.5 Test Result (Plots) of Conducted Emission

Band :	WCDMA Band IV	Channel :	CH1413
Test Mode :	RMC 12.2Kbps Link (QPSK)	Frequency :	1732.6 MHz

Conducted Spurious Emission Plot between 30MHz ~ 1GHz

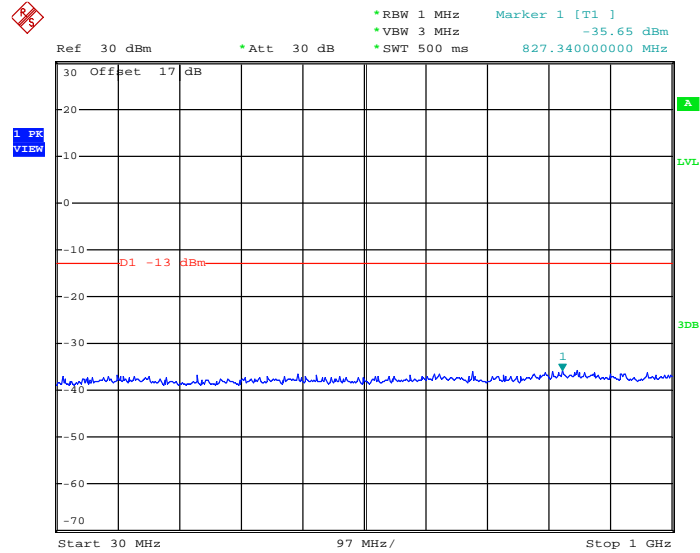

Date: 9.AUG.2013 15:34:15

Conducted Spurious Emission Plot between 1GHz ~ 3GHz

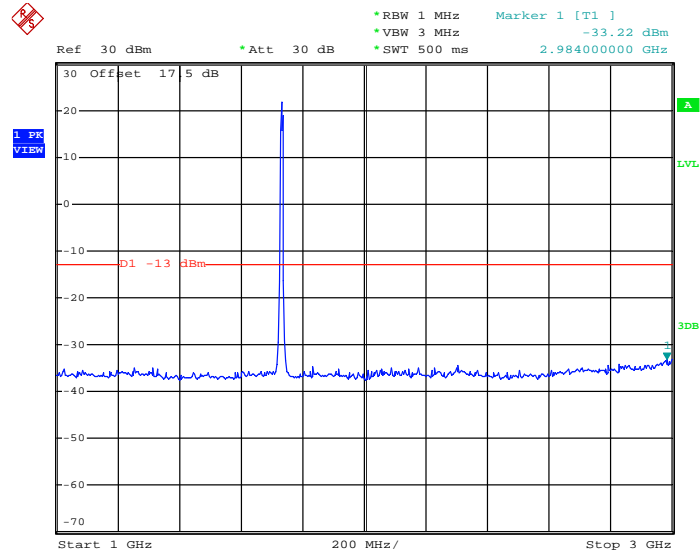

Date: 9.AUG.2013 15:35:16



Conducted Spurious Emission Plot between 3GHz ~ 7GHz

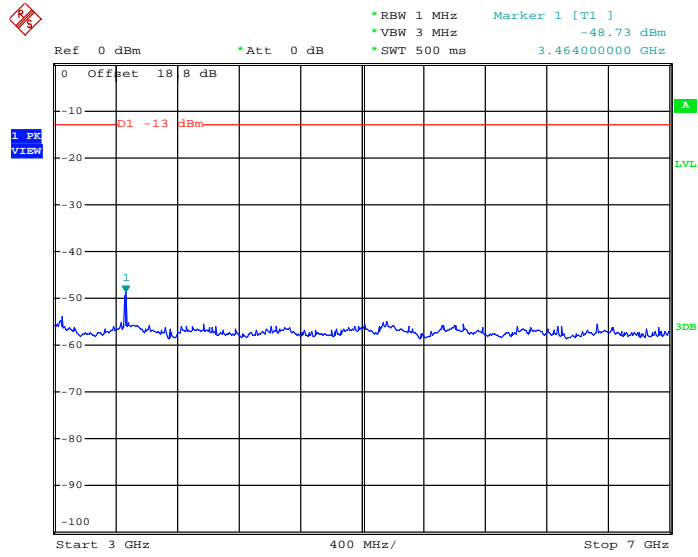

Date: 9.AUG.2013 15:37:13

Conducted Spurious Emission Plot between 7GHz ~ 13.6GHz

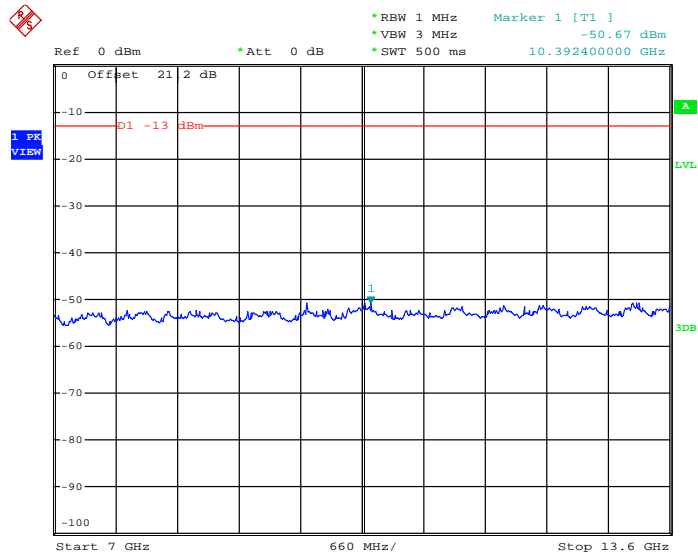

Date: 9.AUG.2013 15:38:08



Conducted Spurious Emission Plot between 13.6GHz ~ 18GHz

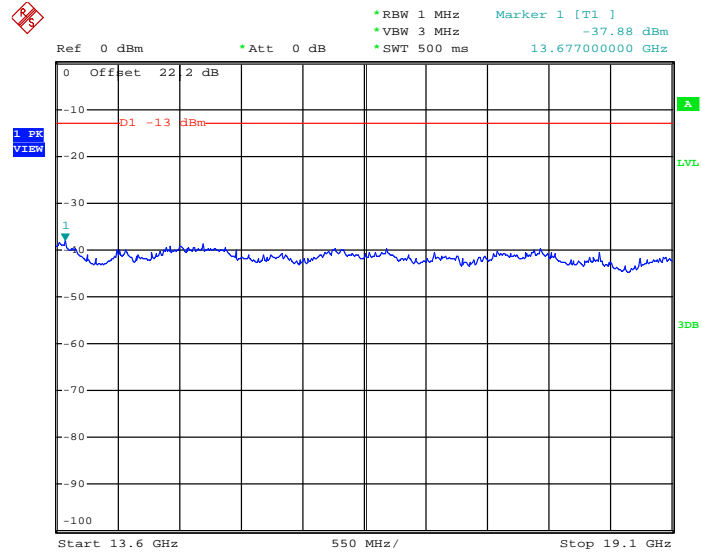

Date: 9.AUG.2013 15:39:04



3.7 Field Strength of Spurious Radiation Measurement

3.7.1 Description of Field Strength of Spurious Radiated Measurement

The power of any emission outside of the authorized operating frequency ranges must be attenuated below the transmitter power (P) by a factor of at least $43 + 10 \log(P)$ dB. The spectrum is scanned from 30 MHz up to a frequency including its 10th harmonic.

3.7.2 Measuring Instruments

See list of measuring instruments of this test report.

3.7.3 Test Procedures

1. The EUT was placed on a rotatable wooden table with 0.8 meter above ground.
2. The EUT was set 3 meters from the receiving antenna, which was mounted on the antenna tower.
3. The table was rotated 360 degrees to determine the position of the highest spurious emission.
4. The height of the receiving antenna is varied between one meter and four meters to search the maximum spurious emission for both horizontal and vertical polarizations.
5. Make the measurement with the spectrum analyzer's RBW = 1MHz, VBW = 3MHz, taking the record of maximum spurious emission.
6. A horn antenna was substituted in place of the EUT and was driven by a signal generator.
7. Tune the output power of signal generator to the same emission level with EUT maximum spurious emission.
8. Taking the record of output power at antenna port.
9. Repeat step 7 to step 8 for another polarization.
10. The RF fundamental frequency should be excluded against the limit line in the operating frequency band.
11. The limit line is derived from $43 + 10\log(P)$ dB below the transmitter power P(Watts)
 $= P(W) - [43 + 10\log(P)] \text{ (dB)}$
 $= [30 + 10\log(P)] \text{ (dBm)} - [43 + 10\log(P)] \text{ (dB)}$
 $= -13\text{dBm}.$
12. $\text{EIRP (dBm)} = \text{S.G. Power} - \text{Tx Cable Loss} + \text{Tx Antenna Gain}$
13. $\text{ERP (dBm)} = \text{EIRP} - 2.15$

3.7.4 Test Setup

For radiated emissions from 30MHz to 1GHz

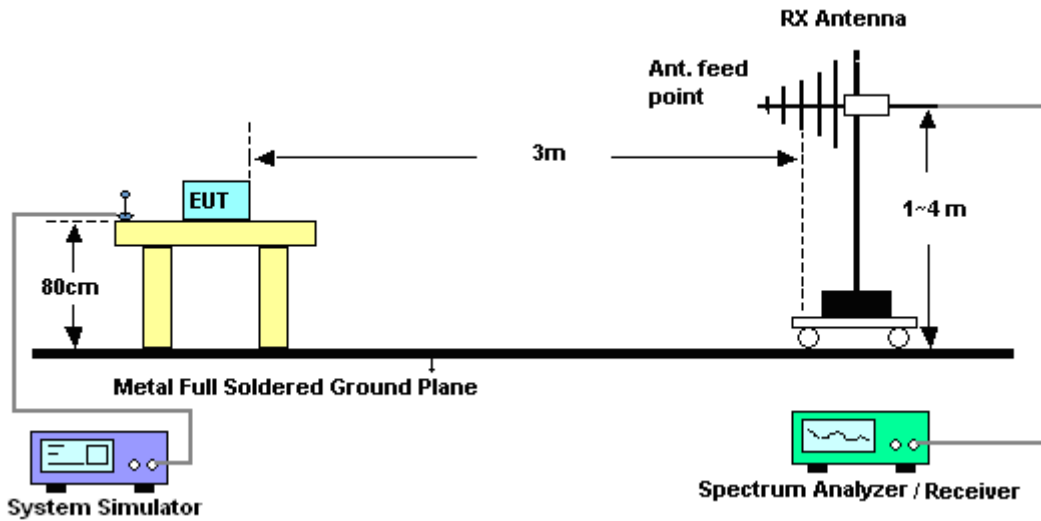

For radiated emissions above 1GHz

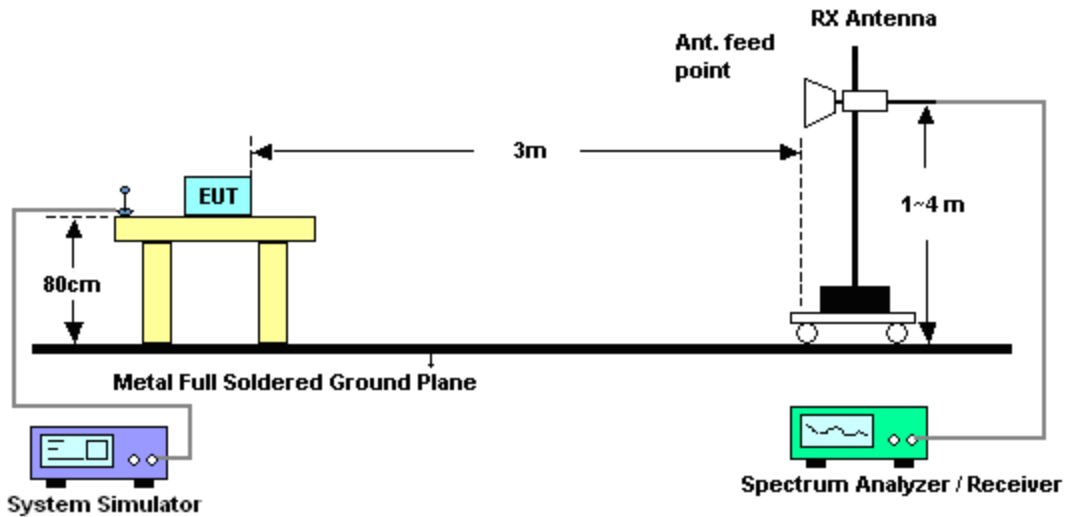



3.7.5 Test Result of Field Strength of Spurious Radiated

Band :	GPRS850	Temperature :	24~25°C
Test Mode :	EDGE class 8 Link (8PSK)	Relative Humidity :	51~54%
Test Engineer :	Robin Luo	Polarization :	Horizontal
Remark :	Spurious emissions within 30-1000MHz were found more than 20dB below limit line.		

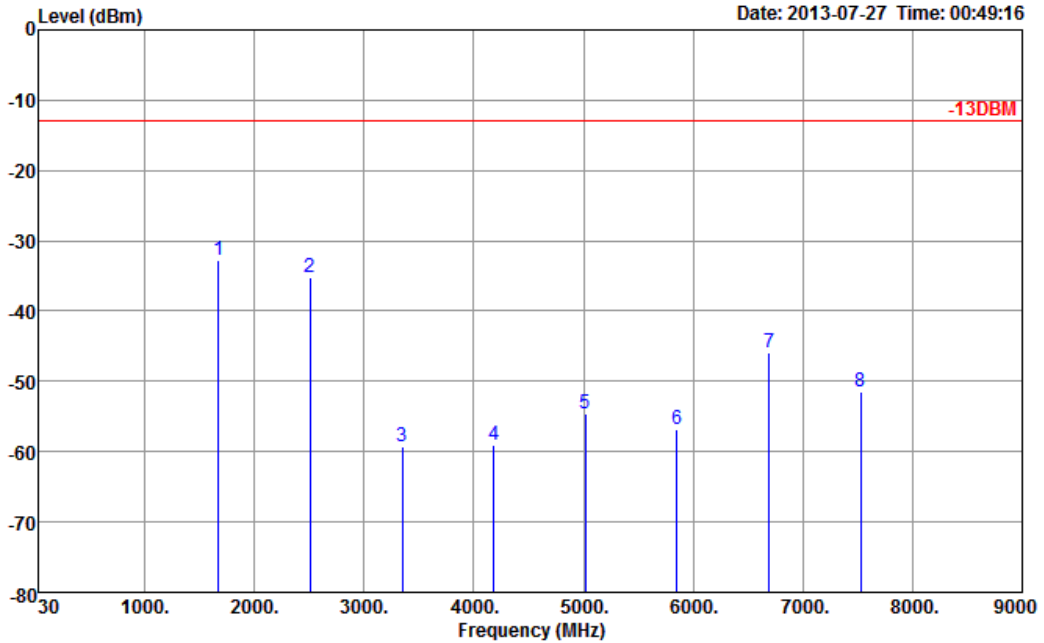

Site : 03CH01-SZ
 Condition : -13DBM HF_EIRP_H_130101 HORIZONTAL
 Project : (FG) 342209-01

Frequency (MHz)	ERP (dBm)	Limit (dBm)	Over Limit (dB)	SPA Reading (dBm)	S.G. Power (dBm)	TX Cable loss (dB)	TX Antenna Gain (dBi)	Polarization (H/V)	Result
1672	-32.78	-13	-19.78	-49.62	-33.43	0.57	3.37	H	Pass
2510	-35.14	-13	-22.14	-60.08	-37.37	0.78	5.16	H	Pass
3346	-59.31	-13	-46.31	-69.91	-62.95	0.87	6.66	H	Pass
4182	-59.15	-13	-46.15	-73.91	-63.74	0.97	7.71	H	Pass
5018	-54.52	-13	-41.52	-72.81	-60.19	1.09	8.91	H	Pass
5854	-56.73	-13	-43.73	-74.95	-63.17	1.22	9.81	H	Pass
6691	-45.93	-13	-32.93	-67.40	-56.80	1.51	11.23	H	Pass
7528	-51.37	-13	-38.37	-74.22	-49.77	1.79	12.11	H	Pass



Band :	GPRS850	Temperature :	24~25°C
Test Mode :	EDGE class 8 Link (8PSK)	Relative Humidity :	51~54%
Test Engineer :	Robin Luo	Polarization :	Vertical
Remark :	Spurious emissions within 30-1000MHz were found more than 20dB below limit line.		

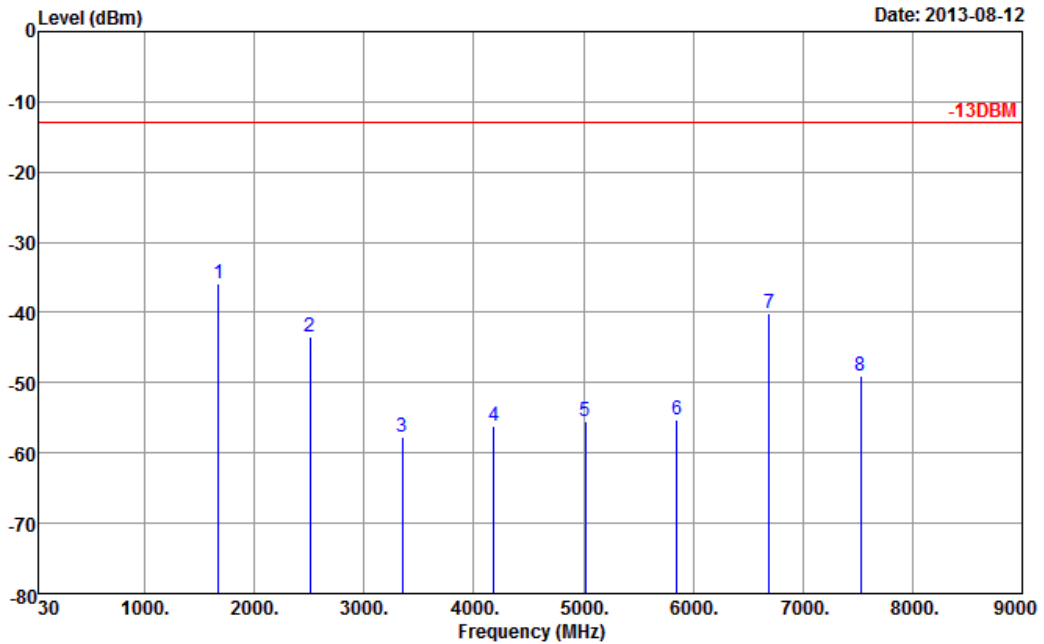

Site : 03CH01-SZ
 Condition : -13DBM HF_EIRP_V_130101 VERTICAL
 Project : (FG) 342209-01

Frequency (MHz)	ERP (dBm)	Limit (dBm)	Over Limit (dB)	SPA Reading (dBm)	S.G. Power (dBm)	TX Cable loss (dB)	TX Antenna Gain (dBi)	Polarization (H/V)	Result
1672	-35.84	-13	-22.84	-49.87	-36.49	0.57	3.37	V	Pass
2510	-43.56	-13	-30.56	-64.99	-45.79	0.78	5.16	V	Pass
3346	-57.70	-13	-44.70	-69.53	-61.34	0.87	6.66	V	Pass
4182	-56.08	-13	-43.08	-71.30	-60.67	0.97	7.71	V	Pass
5018	-55.48	-13	-42.48	-72.93	-61.15	1.09	8.91	V	Pass
5854	-55.37	-13	-42.37	-73.27	-61.81	1.22	9.81	V	Pass
6691	-40.16	-13	-27.16	-61.12	-42.62	1.51	11.23	V	Pass
7528	-49.10	-13	-36.10	-71.26	-55.15	1.79	12.11	V	Pass



Band :	GPRS1900	Temperature :	24~25°C
Test Mode :	EDGE class 8 Link (8PSK)	Relative Humidity :	51~54%
Test Engineer :	Robin Luo	Polarization :	Horizontal
Remark :	Spurious emissions within 30-1000MHz were found more than 20dB below limit line.		

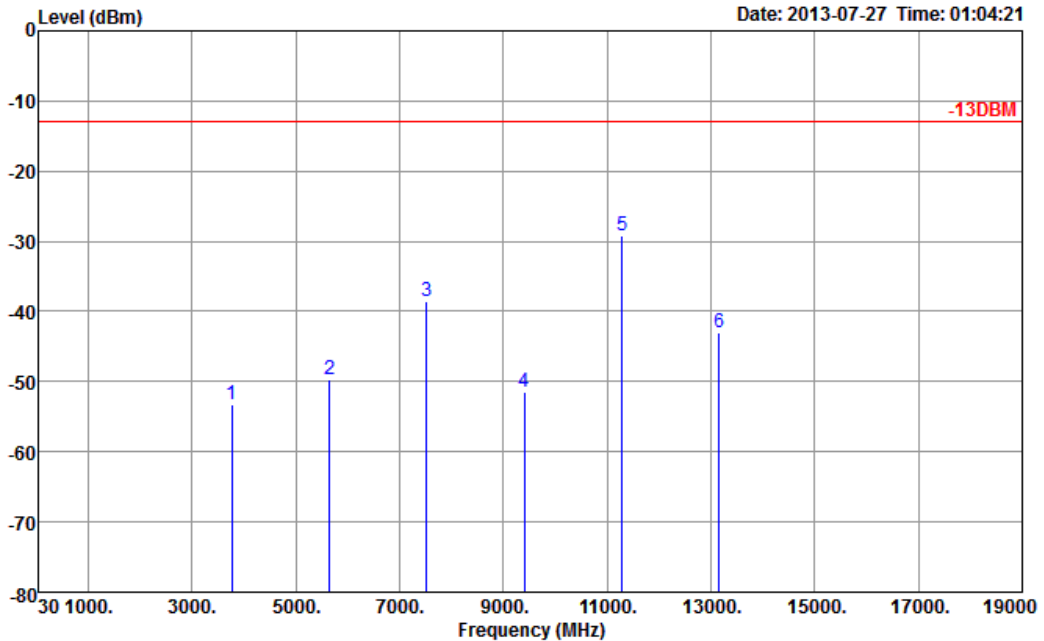

Site : 03CH01-SZ
 Condition : -13DBM HF_EIRP_H_130101 HORIZONTAL
 Project : (FG) 342209-01

Frequency (MHz)	EIRP (dBm)	Limit (dBm)	Over Limit (dB)	SPA Reading (dBm)	S.G. Power (dBm)	TX Cable loss (dB)	TX Antenna Gain (dBi)	Polarization (H/V)	Result
3760	-53.18	-13	-40.18	-65.33	-59.92	1.28	8.02	H	Pass
5640	-49.62	-13	-36.62	-67.61	-58.04	1.58	10.00	H	Pass
7520	-38.65	-13	-25.65	-62.59	-48.97	1.78	12.10	H	Pass
9400	-51.44	-13	-38.44	-73.56	-62.22	2.22	13.00	H	Pass
11280	-29.27	-13	-16.27	-60.58	-40.12	2.16	13.01	H	Pass
13160	-42.95	-13	-29.95	-73.53	-54.01	2.64	13.70	H	Pass



Band :	GPRS1900	Temperature :	24~25°C
Test Mode :	EDGE class 8 Link (8PSK)	Relative Humidity :	51~54%
Test Engineer :	Robin Luo	Polarization :	Vertical
Remark :	Spurious emissions within 30-1000MHz were found more than 20dB below limit line.		

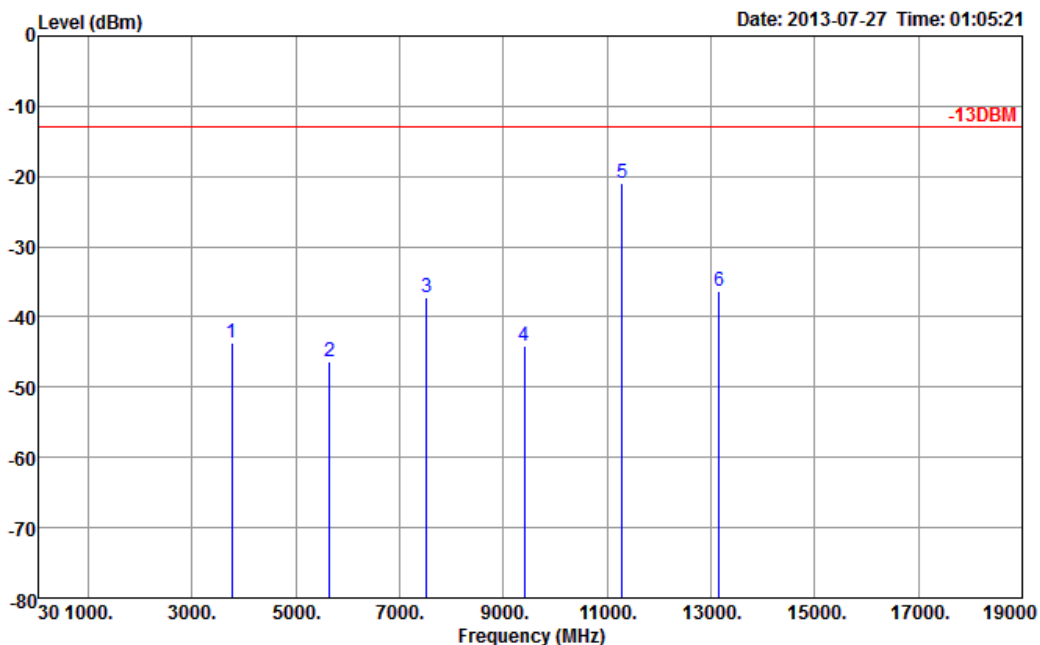

Site : 03CH01-SZ
 Condition : -13DBM HF_EIRP_V_130101 VERTICAL
 Project : (FG) 342209-01

Frequency (MHz)	EIRP (dBm)	Limit (dBm)	Over Limit (dB)	SPA Reading (dBm)	S.G. Power (dBm)	TX Cable loss (dB)	TX Antenna Gain (dBi)	Polarization (H/V)	Result
3760	-43.71	-13	-30.71	-59.88	-50.45	1.28	8.02	V	Pass
5640	-46.39	-13	-33.39	-63.74	-54.81	1.58	10	V	Pass
7520	-37.12	-13	-24.12	-60.94	-47.44	1.78	12.1	V	Pass
9400	-44.04	-13	-31.04	-67.66	-54.82	2.22	13	V	Pass
11280	-20.87	-13	-7.87	-52.55	-31.72	2.16	13.01	V	Pass
13160	-36.38	-13	-23.38	-67.03	-47.44	2.64	13.7	V	Pass



Band :	WCDMA Band IV	Temperature :	24~25°C
Test Mode :	RMC 12.2Kbps Link (QPSK)	Relative Humidity :	51~54%
Test Engineer :	Robin Luo	Polarization :	Horizontal
Remark :	Spurious emissions within 30-1000MHz were found more than 20dB below limit line.		

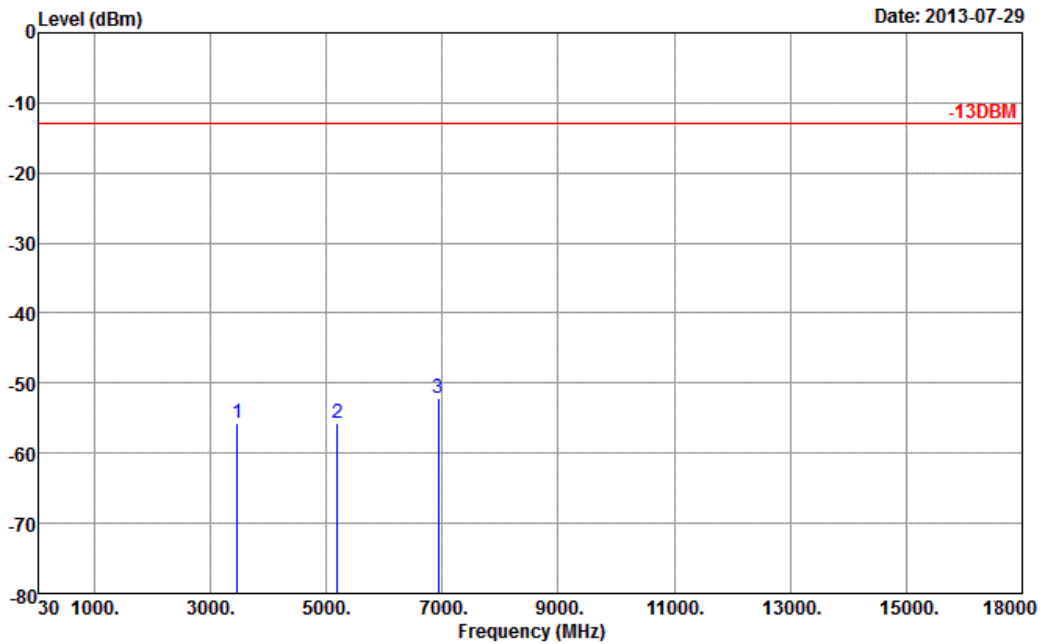

Site : 03CH01-SZ
 Condition : -13DBM HF_EIRP_H_130101 HORIZONTAL
 Project : (FG) 342209-01

Frequency (MHz)	EIRP (dBm)	Limit (dBm)	Over Limit (dB)	SPA Reading (dBm)	S.G. Power (dBm)	TX Cable loss (dB)	TX Antenna Gain (dBi)	Polarization (H/V)	Result
3462	-55.81	-13	-42.81	-66.89	-38.20	12.82	7.54	H	Pass
5196	-55.75	-13	-42.75	-74.71	-68.60	1.58	9.80	H	Pass
6924	-52.19	-13	-39.19	-75.81	-67.90	1.69	11.51	H	Pass



Band :	WCDMA Band IV	Temperature :	24~25°C
Test Mode :	RMC 12.2Kbps Link (QPSK)	Relative Humidity :	51~54%
Test Engineer :	Robin Luo	Polarization :	Vertical
Remark :	Spurious emissions within 30-1000MHz were found more than 20dB below limit line.		

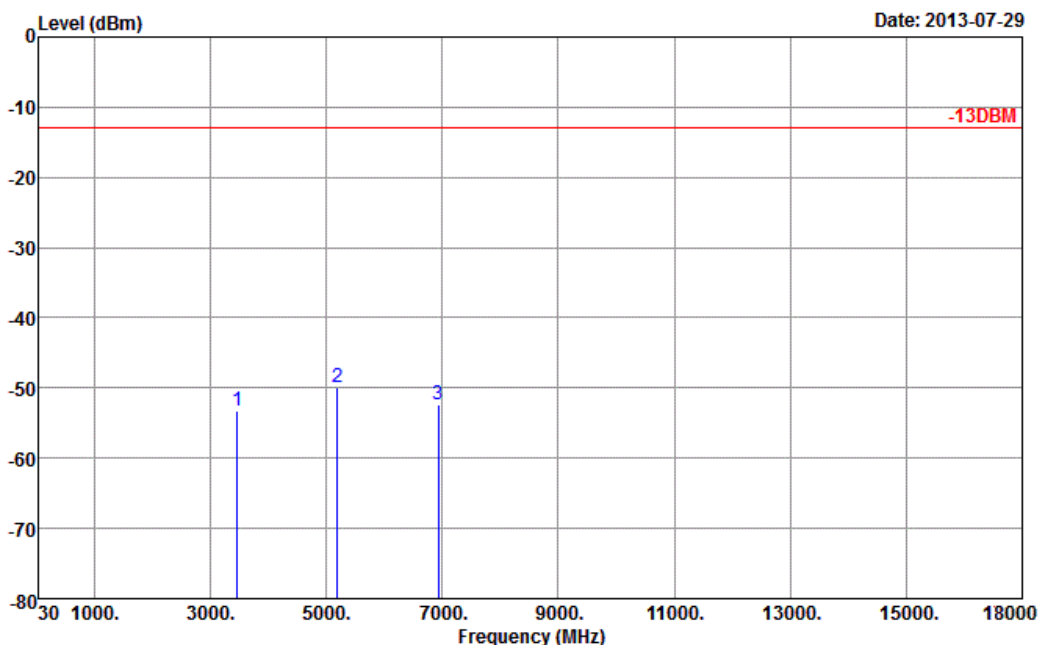

Site : 03CH01-SZ
 Condition : -13DBM HF_EIRP_V_130101 VERTICAL
 Project : (FG) 342209-01

Frequency (MHz)	EIRP (dBm)	Limit (dBm)	Over Limit (dB)	SPA Reading (dBm)	S.G. Power (dBm)	TX Cable loss (dB)	TX Antenna Gain (dBi)	Polarization (H/V)	Result
3462	-53.25	-13	-40.25	-66.11	-43.20	1.42	7.54	V	Pass
5196	-49.82	-13	-36.82	-69.22	-70.30	1.58	9.80	V	Pass
6924	-52.35	-13	-39.35	-75.68	-64.60	1.69	11.51	V	Pass



Band :	WCDMA Band II	Temperature :	24~25°C
Test Mode :	RMC 12.2Kbps Link (QPSK)	Relative Humidity :	51~54%
Test Engineer :	Robin Luo	Polarization :	Horizontal
Remark :	Spurious emissions within 30-1000MHz were found more than 20dB below limit line.		

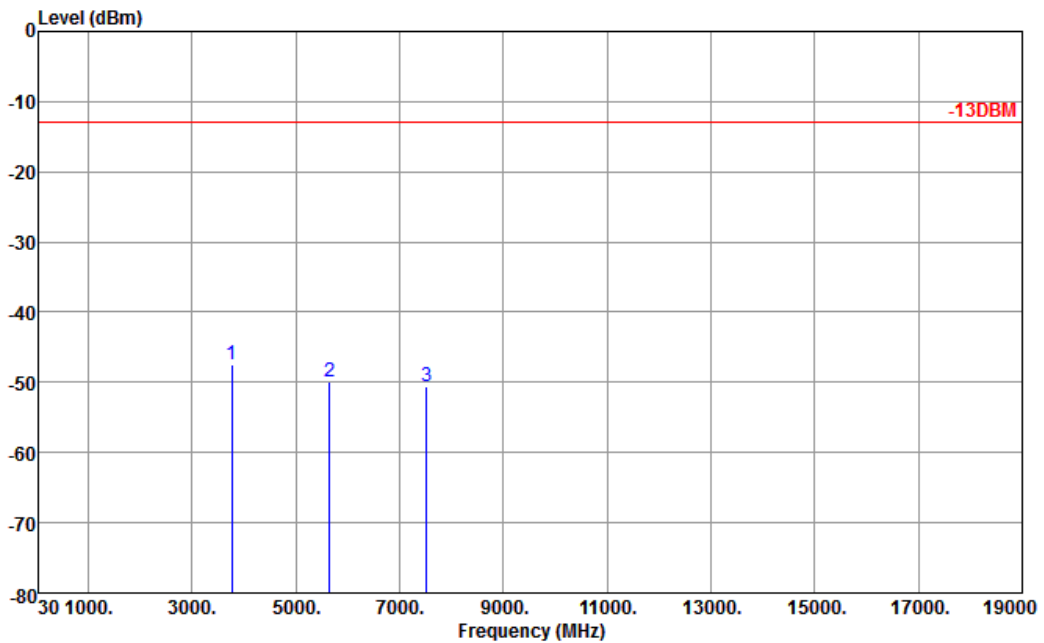

Site : 03CH01-SZ
 Condition : -13DBM HF_EIRP_H_130101 HORIZONTAL

Frequency (MHz)	EIRP (dBm)	Limit (dBm)	Over Limit (dB)	SPA Reading (dBm)	S.G. Power (dBm)	TX Cable loss (dB)	TX Antenna Gain (dBi)	Polarization (H/V)	Result
3760	-47.47	-13	-34.47	-61.83	-54.21	1.28	8.02	H	Pass
5640	-49.90	-13	-36.90	-67.89	-58.32	1.58	10.00	H	Pass
7520	-50.68	-13	-37.68	-72.62	-61.00	1.78	12.10	H	Pass



Band :	WCDMA Band II	Temperature :	24~25°C
Test Mode :	RMC 12.2Kbps Link (QPSK)	Relative Humidity :	51~54%
Test Engineer :	Robin Luo	Polarization :	Vertical
Remark :	Spurious emissions within 30-1000MHz were found more than 20dB below limit line.		

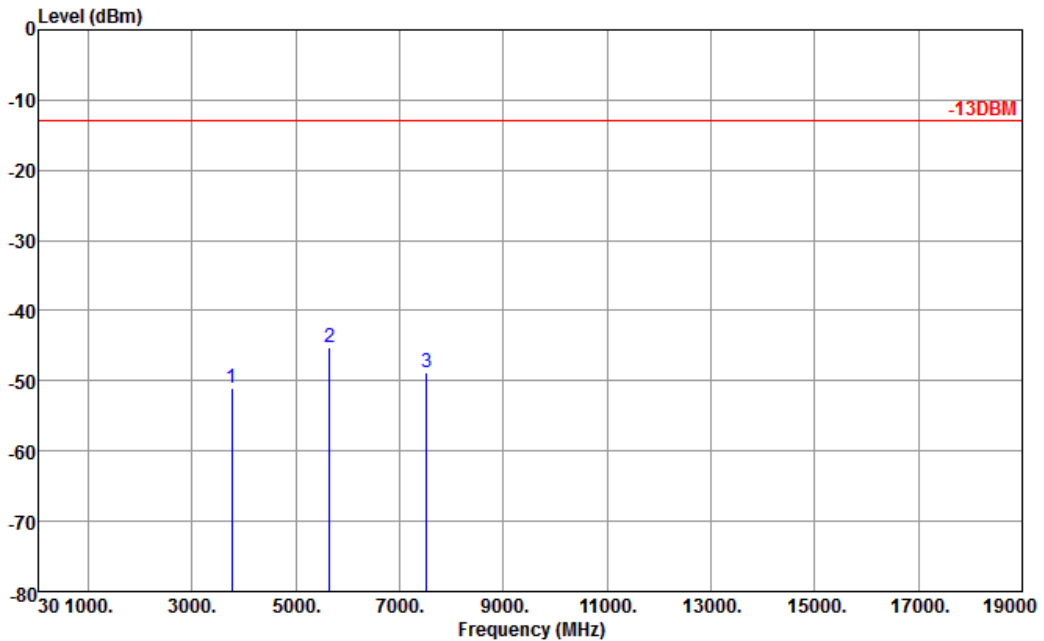

Site : 03CH01-SZ
 Condition : -13DBM HF_EIRP_V_130101 VERTICAL

Frequency (MHz)	EIRP (dBm)	Limit (dBm)	Over Limit (dB)	SPA Reading (dBm)	S.G. Power (dBm)	TX Cable loss (dB)	TX Antenna Gain (dBi)	Polarization (H/V)	Result
3760	-51.13	-13	-38.13	-66.16	-57.87	1.28	8.02	V	Pass
5640	-45.21	-13	-32.21	-62.82	-53.63	1.58	10	V	Pass
7520	-48.78	-13	-35.78	-71.03	-59.10	1.78	12.1	V	Pass

3.8 Frequency Stability Measurement

3.8.1 Description of Frequency Stability Measurement

The frequency stability shall be measured by variation of ambient temperature and variation of primary supply voltage to ensure that the fundamental emission stays within the authorized frequency block. The frequency stability of the transmitter shall be maintained within $\pm 0.00025\%$ ($\pm 2.5\text{ppm}$) of the center frequency.

3.8.2 Measuring Instruments

See list of measuring instruments of this test report.

3.8.3 Test Procedures for Temperature Variation

1. The EUT was set up in the thermal chamber and connected with the base station.
2. With power OFF, the temperature was decreased to -30°C and the EUT was stabilized before testing. Power was applied and the maximum change in frequency was recorded within one minute.
3. With power OFF, the temperature was raised in 10°C step up to 50°C . The EUT was stabilized at each step for at least half an hour. Power was applied and the maximum frequency change was recorded within one minute.
4. If the EUT cannot be turned on at -30°C , the testing lowest temperature will be raised in 10°C step until the EUT can be turned on.

3.8.4 Test Procedures for Voltage Variation

1. The EUT was placed in a temperature chamber at $25\pm 5^{\circ}\text{C}$ and connected with the base station.
2. The power supply voltage to the EUT was varied from BEP to 115% of the nominal value measured at the input to the EUT.
3. The variation in frequency was measured for the worst case.

3.8.5 Test Setup

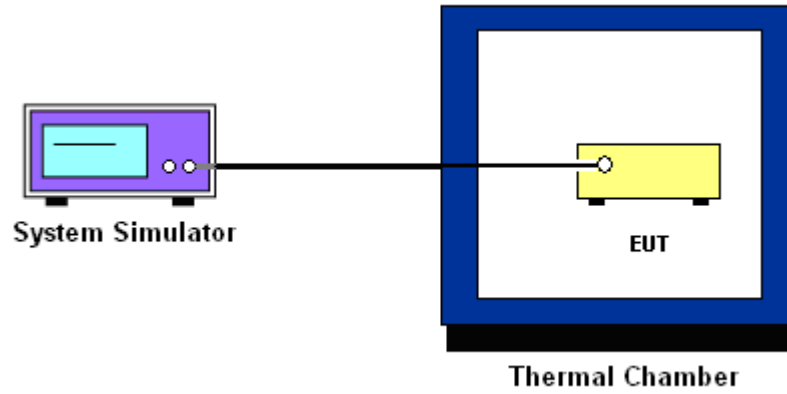



3.8.6 Test Result of Temperature Variation

Band :	WCDMA Band IV	Channel :	1413
Limit (ppm) :	2.5	Frequency :	1732.6 MHz

Temperature (°C)	RMC 12.2Kbps		Result
	Freq. Dev. (Hz)	Deviation (ppm)	
-30	13	+0.01	PASS
-20	15	+0.01	
-10	11	+0.01	
0	9	+0.01	
10	8	+0.00	
20	11	+0.01	
30	12	+0.01	
40	16	+0.01	
50	14	+0.01	

3.8.7 Test Result of Voltage Variation

Band & Channel	Mode	Voltage (Volt)	Freq. Dev. (Hz)	Deviation (ppm)	Limit (ppm)	Result
WCDMA Band IV CH1413	RMC 12.2Kbps	3.8	10	+0.01	2.5	PASS
		3.4	9	+0.01		
		4.2	12	+0.01		

Note: Normal Voltage = 3.8V.



4 List of Measuring Equipment

Instrument	Manufacturer	Model No.	Serial No.	Characteristics	Calibration Date	Test Date	Due Date	Remark
Spectrum Analyzer	R&S	FSP30	101400	9kHz~30GHz	Mar. 28, 2013	Aug. 09, 2013	Mar. 27, 2014	Conducted (TH01-SZ)
Power Meter	Anritsu	ML2495A	1218010	N/A	Mar. 28, 2013	Aug. 09, 2013	Mar. 27, 2014	Conducted (TH01-SZ)
Power Sensor	Anritsu	MA2411B	1207253	N/A	Mar. 28, 2013	Aug. 09, 2013	Mar. 27, 2014	Conducted (TH01-SZ)
Thermal Chamber	Hongzhan	LP-150U	HD20120425	N/A	Mar. 28, 2013	Aug. 09, 2013	Mar. 27, 2014	Conducted (TH01-SZ)
ESCI TEST Receiver	R&S	ESCI	100724	9kHz-3GHz	Mar. 28, 2013	Jul. 27, 2013~ Aug. 12, 2013	Mar. 27, 2014	Radiation (03CH01-SZ)
Spectrum Analyzer	R&S	FSP30	101362	9kHz~30GHz	Oct. 11, 2012	Jul. 27, 2013~ Aug. 12, 2013	Oct. 10, 2013	Radiation (03CH01-SZ)
Double Ridge Horn Antenna	ETS Lindgren	3117	00119436	1GHz~18GHz	Oct. 12, 2012	Jul. 27, 2013~ Aug. 12, 2013	Oct. 11, 2013	Radiation (03CH01-SZ)
Bilog Antenna	SCHAFFNER	CBL6112B	2614	30MHz~2GHz	Nov. 03, 2012	Jul. 27, 2013~ Aug. 12, 2013	Nov. 02, 2013	Radiation (03CH01-SZ)
Amplifier	ADVANTEST	BB525C	E9007003	9kHz-3000MHz GAIN 30db	Mar. 28, 2013	Jul. 27, 2013~ Aug. 12, 2013	Mar. 27, 2014	Radiation (03CH01-SZ)
Amplifier	Yiai	AV3860B	04030	2GHz~26.5GHz	Mar. 28, 2013	Jul. 27, 2013~ Aug. 12, 2013	Mar. 27, 2014	Radiation (03CH01-SZ)
SHF-EHF-Horn	Schwarzbeck	BBHA9170	BBHA9170249	14GHz~40GHz	Nov. 23, 2012	Jul. 27, 2013~ Aug. 12, 2013	Nov. 22, 2013	Radiation (03CH01-SZ)
Turn Table	EM Electronics	EM 1000	N/A	0 ~ 360 degree	N/A	Jul. 27, 2013~ Aug. 12, 2013	N/A	Radiation (03CH01-SZ)
Antenna Mast	EM Electronics	EM 1000	N/A	1 m - 4 m	N/A	Jul. 27, 2013~ Aug. 12, 2013	N/A	Radiation (03CH01-SZ)
Spectrum Analyzer	R&S	FSP 7	100818	9kHz~7GHz	Aug. 22, 2012	Jul. 28, 2013	Aug. 21, 2013	Radiation (OTA01-SZ)
Quad-Ridged Horn	ETS-Lindgren	3164-08	00102954	700MHz~10000 MHz	N/A	Jul. 28, 2013	N/A	Radiation (OTA01-SZ)
Multi-Devices Controller	ETS-Lindgren	2090-OPT1	00108147	N/A	N/A	Jul. 28, 2013	N/A	Radiation (OTA01-SZ)
Switch Control Mainframe	Agilent	3499A	MY42005451	N/A	N/A	Jul. 28, 2013	N/A	Radiation (OTA01-SZ)



5 Uncertainty of Evaluation

Uncertainty of Radiated Emission Measurement (30 MHz ~ 1000 MHz)

Measuring Uncertainty for a Level of Confidence of 95% ($U = 2Uc(y)$)	2.54
---	------

Uncertainty of Radiated Emission Measurement (1 GHz ~ 40 GHz)

Measuring Uncertainty for a Level of Confidence of 95% ($U = 2Uc(y)$)	4.72
---	------



Appendix B. Product Equality Declaration

TCT Mobile Limited

5F, C building, No. 232, Liang Jing Road,Zhangjiang High-Tech Park, Pudong,Shanghai,China

Tel: +86(0)2161460890 ; Fax: +86(0)2161460600

Date: August 20, 2013

Product Equality Declaration

We, TCT Mobile Limited, declare on our sole responsibility for the product of M600Q (FCC ID: RAD425) as below:

The differences between M600Q and previous M600Y (FCC ID: RAD383) are as below:

1. Add B4 TX/RX chain: Components new add:

SAFEA1G73AA0F00	MURATA	SAW Filter FOR UMTS BC4 Tx,1732.5MHz,1.35×1.05×0.5mm,5pin,,SAFEA1G73AA0F00,MURATA,
ACPM-5004-TR1/BLK	AVAGO	Multimode PA,UMTS 1700MHz PA(1710-1785MHz),3×3mm,,, ACPM-5004-TR1/BLK,AVAGO,
B39212B7959P810	EPCOS	SAW Duplexer,W-CDMA Band 4/CDMA 1x AWS Band,1732.5/2132.5MHz,2.5×2.0× 0.89mm,9pin,,B39212B7959P810,EPCOS,

2. Change B5 to B8 TX/RX chain: Components change list:

B8	ACPM-5208-TR1	AVAGO	PA,UMTS Band8 (880-915MHz),3×3mm,,ACPM-5208-TR1,AVAGO
B5	ACPM-5205-TR1	AVAGO	PA,UMTS Band5 (824-849MHz),3× 3mm,,ACPM-5205-TR1,AVAGO,
B8	B39941B7921P810	EPCOS	SAW duplexer WCDMA band VIII,897.5/942.5MHz,2.5×2.0×0.68mm,,B39941B7921P810, EPCOS,,
B5	B39881B7671A710	EPCOS	SAW Duplexer Cellular / WCDMA Band V,836.50/881.50MHz,2.5×2.0× 0.68mm,,B39881B7671A710,EPCOS,
B8	B39941B9449M410	EPCOS	SAW RX filter,WCDMA band VIII / GSM 900,942.5MHz,1.4×1.1×0.4mm,,B39941B9449M410,EPCOS,
B5	B39881B9439M410	EPCOS	SAW Rx filter,Cellular / WCDMA Band V,881.5MHz,1.4×1.1×0.4mm,,B39881B9439M410,EPCOS,

Except listings above, the other relevant parts are the same as previous version.

Based on the similarity between two models, the GSM bands and WCDMA Band 2 have the same circuit and layout. So the original modular report for M600Y with FCC ID:RAD383 (Sporton Report Number: FG342209), was submitted to represent the compliance of Part 22/24

conducted RF testing items for GSM bands and band2, for the new band IV is performed for full testing for this application M600Q (FCC ID: RAD425)

Should you have any questions or comments regarding this matter, please have my best attention.

Sincerely yours,

Gong Zhizhou

Contact Person: Zhizhou Gong

Company: TCT Mobile Limited

TEL: +86(0)2161460890

FAX: +86(0)2161460600

E-mail: zhizhou.gong@jrdcom.com