



TEST REPORT

Product Name	UMTS Triband / GSM Quadband mobile phone
Model Name	RAV4 TMOUS
Brand Name	ALCATEL
Marketing Name	ONE TOUCH 7024W
FCC ID	RAD386
Client	TCT Mobile Limited
Manufacturer	TCT Mobile Limited
Date of issue	August 25, 2013

TA Technology (Shanghai) Co., Ltd.

TA Technology (Shanghai) Co., Ltd.
Test Report

Report No.: RXA1307-0093SAR01R3

Page 2 of 225

GENERAL SUMMARY

Reference Standard(s)	<p>FCC 47CFR §2.1093 Radiofrequency Radiation Exposure Evaluation: Portable Devices</p> <p>ANSI C95.1, 1992: Safety Levels with Respect to Human Exposure to Radio Frequency Electromagnetic Fields, 3 kHz to 300 GHz.(IEEE Std C95.1-1991)</p> <p>IEEE Std 1528™-2003: IEEE Recommended Practice for Determining the Peak Spatial-Average Specific Absorption Rate (SAR) in the Human Head from Wireless Communications Devices: Measurement Techniques.</p> <p>KDB 865664 D01 SAR measurement 100 MHz to 6 GHz v01r01: SAR Measurement Requirements for 100 MHz to 6 GHz</p> <p>KDB 447498 D01 Mobile Portable RF Exposure v05r01: Mobile and Portable Device RF Exposure Procedures and Equipment Authorization Policies</p> <p>KDB 648474 D04 Handset SAR v01r01: SAR Evaluation Considerations for Wireless Handsets.</p> <p>KDB 941225 D01 SAR test for 3G devices v02: SAR Measurement Procedures CDMA 20001x RTT, 1x Ev-Do, WCDMA, HSDPA/HSPA</p> <p>KDB 941225 D02 HSPA and 1x Advanced v02r02 SAR Guidance for HSPA, HSPA+, DC-HSDPA and 1x-Advanced</p> <p>KDB 941225 D03 Test Reduction GSM_GPRS_EDGE v01:Recommended SAR Test Reduction Procedures for GSM/GPRS/EDGE</p> <p>KDB 941225 D06 Hotspot Mode SAR v01r01: SAR Evaluation Procedures for Portable Devices with Wireless Router Capabilities</p>
Conclusion	<p>This portable wireless equipment has been measured in all cases requested by the relevant standards. Test results in Chapter 7 of this test report are below limits specified in the relevant standards for the tested bands only.</p> <p>General Judgment: Pass</p>
Comment	<p>The test result only responds to the measured sample.</p>

Approved by 杨伟中
Director

Revised by 凌敏宝
SAR Manager

Performed by 张磊
SAR Engineer

TABLE OF CONTENT

1. General Information	5
1.1. Notes of the Test Report.....	5
1.2. Testing Laboratory	5
1.3. Applicant Information	6
1.4. Manufacturer Information.....	6
1.5. Information of EUT.....	7
1.6. The Maximum Reported SAR _{1g}	9
1.7. Test Date	10
2. SAR Measurements System Configuration.....	11
2.1. SAR Measurement Set-up.....	11
2.2. DASY5 E-field Probe System	12
2.2.1. EX3DV4 Probe Specification	12
2.2.2. E-field Probe Calibration	13
2.3. Other Test Equipment	13
2.3.1. Device Holder for Transmitters	13
2.3.2. Phantom	14
2.4. Scanning Procedure	14
2.5. Data Storage and Evaluation	16
2.5.1. Data Storage.....	16
2.5.2. Data Evaluation by SEMCAD	16
3. Laboratory Environment.....	18
4. Tissue-equivalent Liquid	19
4.1. Tissue-equivalent Liquid Ingredients.....	19
4.2. Tissue-equivalent Liquid Properties	21
5. System Check.....	22
5.1. Description of System Check.....	22
5.2. System Check Results.....	25
6. Operational Conditions during Test	26
6.1. General Description of Test Procedures	26
6.2. Test Positions.....	26
6.2.1. Against Phantom Head.....	26
6.2.2. Body Worn Configuration.....	26
6.3. Measurement Variability.....	27
6.4. Test Configuration	28
6.4.1. GSM Test Configuration.....	28
6.4.2. UMTS Test Configuration	28
6.4.3. HSDPA Test Configuration	29
6.4.4. WIFI Test Configuration	34
6.4.5. BT Test Configuration	34
7. Test Results	35
7.1. Conducted Power Results	35

TA Technology (Shanghai) Co., Ltd.

Test Report

Report No.: RXA1307-0093SAR01R3

Page 4 of 225

7.2.	Standalone SAR Test Exclusion Considerations	42
7.3.	SAR Test Results	43
7.3.1.	GSM 850 (GPRS)	43
7.3.2.	GSM 1900 (GPRS)	44
7.3.3.	UMTS Band II (WCDMA/HSDPA/HSUPA/DC-HSDPA)	46
7.3.4.	UMTS Band IV (WCDMA/HSDPA/HSUPA/DC-HSDPA)	47
7.3.5.	UMTS Band V (WCDMA/HSDPA/HSUPA/DC-HSDPA)	49
7.3.6.	WIFI (802.11b)	50
7.3.7.	BT	51
7.4.	Simultaneous Transmission Conditions	52
8.	700MHz to 3GHz Measurement Uncertainty	57
9.	Main Test Instruments	59
ANNEX A:	Test Layout	60
ANNEX B:	System Check Results	65
ANNEX C:	Graph Results	74
ANNEX D:	Probe Calibration Certificate	170
ANNEX E:	D835V2 Dipole Calibration Certificate	181
ANNEX F:	D1750V2 Dipole Calibration Certificate	189
ANNEX G:	D1900V2 Dipole Calibration Certificate	197
ANNEX H:	D2450V2 Dipole Calibration Certificate	205
ANNEX I:	DAE4 Calibration Certificate	213
ANNEX J:	The EUT Appearances and Test Configuration	218

TA Technology (Shanghai) Co., Ltd. Test Report

Report No.: RXA1307-0093SAR01R3

Page 5 of 225

1. General Information

1.1. Notes of the Test Report

TA Technology (Shanghai) Co., Ltd. has obtained the accreditation of China National Accreditation Service for Conformity Assessment (CNAS), and accreditation number: L2264.

TA Technology (Shanghai) Co., Ltd. guarantees the reliability of the data presented in this test report, which is the results of measurements and tests performed for the items under test on the date and under the conditions stated in this test report and is based on the knowledge and technical facilities available at TA Technology (Shanghai) Co., Ltd. at the time of execution of the test.

TA Technology (Shanghai) Co., Ltd. is liable to the client for the maintenance by its personnel of the confidentiality of all information related to the items under test and the results of the test. This report only refers to the item that has undergone the test.

This report standalone dose not constitute or imply by its own an approval of the product by the certification Bodies or competent Authorities. This report cannot be used partially or in full for publicity and/or promotional purposes without previous written approval of **TA Technology (Shanghai) Co., Ltd.** and the Accreditation Bodies, if it applies.

If the electrical report is inconsistent with the printed one, it should be subject to the latter.

1.2. Testing Laboratory

Company: TA Technology (Shanghai) Co., Ltd.
Address: No.145, Jintang Rd, Tangzhen Industry Park, Pudong Shanghai, China
City: Shanghai
Post code: 201201
Country: P. R. China
Contact: Yang Weizhong
Telephone: +86-021-50791141/2/3
Fax: +86-021-50791141/2/3-8000
Website: <http://www.ta-shanghai.com>
E-mail: yangweizhong@ta-shanghai.com

TA Technology (Shanghai) Co., Ltd.

Test Report

Report No.: RXA1307-0093SAR01R3

Page 6 of 225

1.3. Applicant Information

Company: TCT Mobile Limited
Address: 5F, C building, No. 232, Liang Jing Road ZhangJiang High-Tech Park,
Pudong Area Shanghai, P.R. China.
City: Shanghai
Postal Code: 201203
Country: P.R. China

1.4. Manufacturer Information

Company: TCT Mobile Limited
Address: 5F, C building, No. 232, Liang Jing Road ZhangJiang High-Tech Park,
Pudong Area Shanghai, P.R. China.
City: Shanghai
Postal Code: 201203
Country: P.R. China

TA Technology (Shanghai) Co., Ltd.

Test Report

Report No.: RXA1307-0093SAR01R3

Page 7 of 225

1.5. Information of EUT

General Information

Device Type:	Portable Device		
Exposure Category:	Uncontrolled Environment / General Population		
State of Sample:	Prototype Unit		
Product IMEI:	013775000250714		
Hardware Version:	PIO		
Software Version:	L15		
Antenna Type:	Internal Antenna		
Device Operating Configurations :			
Supporting Mode(s):	GSM 850/GSM 1900; (tested) UMTS Band II/ UMTS Band IV/UMTS Band V; (tested) Bluetooth; (tested) WiFi (802.11b); (tested) GSM 900/GSM 1800; (untested) WiFi (802.11g/nHT20/nHT40); (untested)		
Support Hotspot	Yes, when hot spots opened, WCDMA Band II/IV power will reduced.		
Test Modulation:	(GSM)GMSK; (UMTS)QPSK		
Device Class:	B		
HSDPA UE Category:	14		
HSUPA UE Category:	6		
DC-HSDPA UE Category:	24		
GPRS Multislot Class(12):	Max Number of Timeslots in Uplink	4	
	Max Number of Timeslots in Downlink	4	
	Max Total Timeslot	5	
EGPRS Multislot Class(12):	Max Number of Timeslots in Uplink	4	
	Max Number of Timeslots in Downlink	4	
	Max Total Timeslot	5	
Operating Frequency Range(s):	Mode	Tx (MHz)	Rx (MHz)
	GSM 850	824.2 ~ 848.8	869.2 ~ 893.8
	GSM 1900	1850.2 ~ 1909.8	1930.2 ~ 1989.8
	UMTS Band II	1852.4 ~ 1907.6	1932.4 ~ 1987.6
	UMTS Band IV	1712.4 ~ 1752.6	2112.4 ~ 2152.6
	UMTS Band V	826.4 ~ 846.6	871.4 ~ 891.6
	WIFI(2.4G)	2412 ~ 2462	2412 ~ 2462

TA Technology (Shanghai) Co., Ltd.

Test Report

Report No.: RXA1307-0093SAR01R3

Page 8 of 225

	Bluetooth	2402 ~ 2480	2402 ~ 2480
Power Class:	GSM 850: 4		
	GSM 1900: 1		
	UMTS Band II: 3		
	UMTS Band IV: 3		
	UMTS Band V: 3		
Power Level	GSM 850: tested with power level 5		
	GSM 1900: tested with power level 0		
	UMTS Band II: tested with power control all up bits		
	UMTS Band IV: tested with power control all up bits		
	UMTS Band V: tested with power control all up bits		
Test Channel: (Low - Middle - High)	128 - 190 - 251	(GSM 850)	(tested)
	512 - 661 - 810	(GSM 1900)	(tested)
	9262 - 9400 - 9538	(UMTS Band II)	(tested)
	1312 - 1413 - 1513	(UMTS Band IV)	(tested)
	4132 - 4183 - 4233	(UMTS Band V)	(tested)
	1 - 6 - 11	(802.11b)	(tested)
	0 - 39 - 78	(BT)	(tested)

Auxiliary Equipment Details

AE1: Battery

Model: CAC1800000C3

Manufacturer: SCUD

S/N: /

Equipment Under Test (EUT) has a GSM/UMTS antenna that is used for Tx/Rx, a BT/WIFI antenna that is used for Tx/Rx and a diversity antenna that can be used for Rx. It has Personal Wireless Routers (hot spots) function. The detail about EUT and Lithium Battery is in chapter 1.5 in this report.

The sample under test was selected by the Client.

Components list please refer to documents of the manufacturer.

TA Technology (Shanghai) Co., Ltd.
Test Report

Report No.: RXA1307-0093SAR01R3

Page 9 of 225

1.6. The Maximum Reported SAR_{1g}

Head SAR Configuration

Mode	Test Position	Channel /Frequency(MHz)	Limit SAR _{1g} 1.6 W/kg	
			Measured SAR _{1g} (W/kg)	Reported SAR _{1g} (W/kg)
GSM 850	Left/Cheek	190/836.6	0.0053	0.007
GSM 1900	Left/Cheek	661/1880	0.2820	0.344
UMTS Band II	Right/Cheek	9400/1880	0.5430	0.713
UMTS Band IV	Left/Cheek	1413/1732.6	0.6440	0.783
UMTS Band V	Left/Cheek	4183/836.6	0.0060	0.008
WiFi(802.11b)	Left/Cheek	6/2437	0.6620	0.741
BT	Right/Cheek	0/2402	0.1180	0.126

Body Worn Configuration

Mode	Test Position	Channel /Frequency(MHz)	Limit SAR _{1g} 1.6 W/kg	
			Measured SAR _{1g} (W/kg)	Reported SAR _{1g} (W/kg)
3Txslots GPRS 850	Back Side	190/836.6	0.0295	0.037
2Txslots GPRS 1900	Back Side	512/1850.2	0.8680	1.142
UMTS Band II	Back Side	9262/1852.4	0.6580	0.871
UMTS Band IV	Back Side	1413/1732.6	0.7480	0.910
UMTS Band V	Back Side	4183/836.6	0.0314	0.040
WiFi(802.11b)	Back Side	6/2437	0.2900	0.325
BT	Back Side	0/2402	0.0357	0.038

TA Technology (Shanghai) Co., Ltd.
Test Report

Report No.: RXA1307-0093SAR01R3

Page 10 of 225

Hotspot SAR Configuration

Mode	Test Position	Channel /Frequency(MHz)	Limit SAR _{1g} 1.6 W/kg	
			Measured SAR _{1g} (W/kg)	Reported SAR _{1g} (W/kg)
3Txslots GPRS 850	Back Side	190/836.6	0.0295	0.037
2Txslots GPRS 1900	Back Side	512/1850.2	0.8680	1.142
UMTS Band II	Back Side	9262/1852.4	0.7720	0.956
UMTS Band IV	Back Side	1413/1732.6	0.9380	1.154
UMTS Band V	Back Side	4183/836.6	0.0314	0.040
WiFi(802.11b)	Right Edge	6/2437	0.3210	0.359
BT	Back Side	0/2402	0.0357	0.038

1.7. Test Date

The test performed from July 17, 2013 to August 1, 2013.

2. SAR Measurements System Configuration

2.1. SAR Measurement Set-up

The DASY5 system for performing compliance tests consists of the following items:

- A standard high precision 6-axis robot (Stäubli RX family) with controller and software. An arm extension for accommodating the data acquisition electronics (DAE).
- A dosimetric probe, i.e. an isotropic E-field probe optimized and calibrated for usage in tissue simulating liquid. The probe is equipped with an optical surface detector system.
- A data acquisition electronic (DAE) which performs the signal amplification, signal multiplexing, AD-conversion, offset measurements, mechanical surface detection, collision detection, etc. The unit is battery powered with standard or rechargeable batteries. The signal is optically transmitted to the EOC.
- A unit to operate the optical surface detector which is connected to the EOC.
- The Electro-Optical Coupler (EOC) performs the conversion from the optical into a digital electric signal of the DAE. The EOC is connected to the DASY5 measurement server.
- The DASY5 measurement server, which performs all real-time data evaluation for field measurements and surface detection, controls robot movements and handles safety operation. A computer operating Windows 2003
- DASY5 software and SEMCAD data evaluation software.
- Remote control with teach panel and additional circuitry for robot safety such as warning lamps, etc.
- The generic twin phantom enabling the testing of left-hand and right-hand usage.
- The device holder for handheld mobile phones.
- Tissue simulating liquid mixed according to the given recipes.
- System validation dipoles allowing to validate the proper functioning of the system.

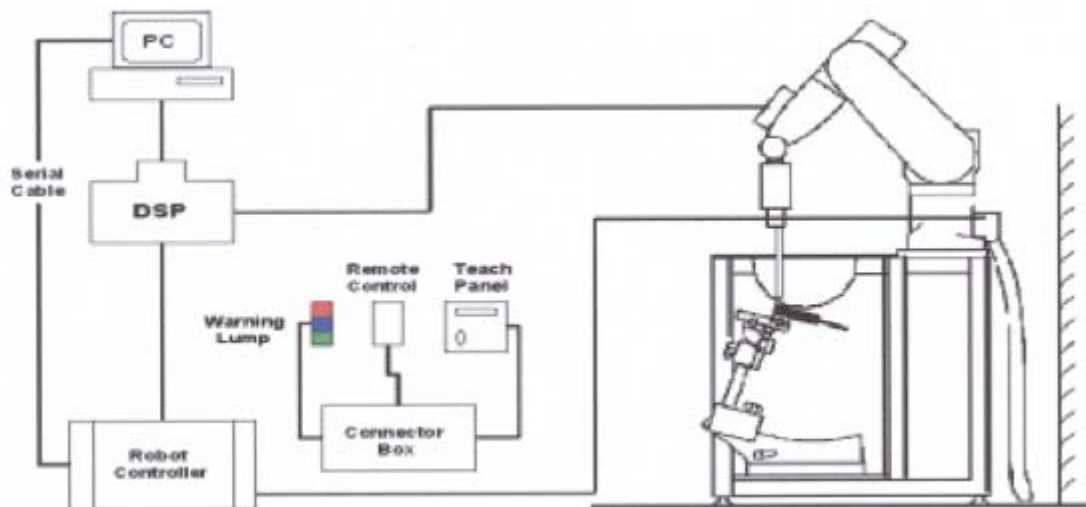

Figure 1 SAR Lab Test Measurement Set-up

2.2. DASY5 E-field Probe System

The SAR measurements were conducted with the dosimetric probe EX3DV4 (manufactured by SPEAG), designed in the classical triangular configuration and optimized for dosimetric evaluation.

2.2.1. EX3DV4 Probe Specification

Construction	Symmetrical design with triangular core Built-in shielding against static charges PEEK enclosure material (resistant to organic solvents, e.g., DGBE)
Calibration	ISO/IEC 17025 calibration service available
Frequency	10 MHz to > 6 GHz Linearity: ± 0.2 dB (30 MHz to 6 GHz)
Directivity	± 0.3 dB in HSL (rotation around probe axis) ± 0.5 dB in tissue material (rotation normal to probe axis)
Dynamic Range	10 μ W/g to > 100 mW/g Linearity: ± 0.2 dB (noise: typically < 1 μ W/g)
Dimensions	Overall length: 330 mm (Tip: 20 mm) Tip diameter: 2.5 mm (Body: 12 mm) Typical distance from probe tip to dipole centers: 1 mm
Application	High precision dosimetric measurements in any exposure scenario (e.g., very strong gradient fields). Only probe which enables compliance testing for frequencies up to 6 GHz with precision of better 30%.



Figure 2. EX3DV4 E-field Probe



Figure 3. EX3DV4 E-field probe

2.2.2. E-field Probe Calibration

Each probe is calibrated according to a dosimetric assessment procedure with accuracy better than $\pm 10\%$. The spherical isotropy was evaluated and found to be better than $\pm 0.25\text{dB}$. The sensitivity parameters (NormX, NormY, NormZ), the diode compression parameter (DCP) and the conversion factor (ConvF) of the probe are tested.

The free space E-field from amplified probe outputs is determined in a test chamber. This is performed in a TEM cell for frequencies below 1 GHz, and in a wave guide above 1 GHz for free space. For the free space calibration, the probe is placed in the volumetric center of the cavity and at the proper orientation with the field. The probe is then rotated 360 degrees.

E-field temperature correlation calibration is performed in a flat phantom filled with the appropriate simulated brain tissue. The measured free space E-field in the medium correlates to temperature rise in a dielectric medium. For temperature correlation calibration a RF transparent thermistor-based temperature probe is used in conjunction with the E-field probe.

$$\text{SAR} = C \frac{\Delta T}{\Delta t}$$

Where: Δt = Exposure time (30 seconds),
C = Heat capacity of tissue (brain or muscle),
 ΔT = Temperature increase due to RF exposure.
Or

$$\text{SAR} = \frac{|E|^2 \sigma}{\rho}$$

Where:
 σ = Simulated tissue conductivity,
 ρ = Tissue density (kg/m³).

2.3. Other Test Equipment

2.3.1. Device Holder for Transmitters

The DASY device holder is designed to cope with the different positions given in the standard.

It has two scales for device rotation (with respect to the body axis) and device inclination (with respect to the line between the ear reference points). The rotation centers for both scales is the ear reference point (ERP). Thus the device needs no repositioning when changing the angles.

The amount of dielectric material has been reduced in the closest vicinity of the device, since measurements have suggested that the influence of the clamp on the test results could thus be lowered.



Figure 4 Device Holder

2.3.2. Phantom

The Generic Twin Phantom is constructed of a fiberglass shell integrated in a wooden Figure. The shape of the shell is based on data from an anatomical study designed to determine the maximum exposure in at least 90% of all users. It enables the dosimetric evaluation of left and right hand phone usage as well as body mounted usage at the flat phantom region. A cover prevents the evaporation of the liquid. Reference markings on the Phantom allow the complete setup of all predefined phantom positions and measurement grids by manually teaching three points in the robot.

Shell Thickness	2±0.1 mm
Filling Volume	Approx. 20 liters
Dimensions	810 x 1000 x 500 mm (H x L x W) Available Special



Figure 5 Generic Twin Phantom

2.4. Scanning Procedure

The DASYS5 installation includes predefined files with recommended procedures for measurements and validation. They are read-only document files and destined as fully defined but unmeasured masks. All test positions (head or body-worn) are tested with the same configuration of test steps differing only in the grid definition for the different test positions.

- The “reference” and “drift” measurements are located at the beginning and end of the batch process. They measure the field drift at one single point in the liquid over the complete procedure. The indicated drift is mainly the variation of the DUT’s output power and should vary max. ± 5 %.
- The “surface check” measurement tests the optical surface detection system of the DASYS5 system by repeatedly detecting the surface with the optical and mechanical surface detector and comparing the results. The output gives the detecting heights of both systems, the difference between the two systems and the standard deviation of the detection repeatability. Air bubbles or refraction in the liquid due to separation of the sugar-water mixture gives poor repeatability (above ± 0.1mm). To prevent wrong results tests are only executed when the liquid is free of air bubbles. The difference between the optical surface detection and the actual surface depends on the probe and is specified with each probe. (It does not depend on the surface reflectivity or the probe angle to the surface within ± 30°.)
- Area Scan
The Area Scan is used as a fast scan in two dimensions to find the area of high field values before running a detailed measurement around the hot spot. Before starting the area scan a grid

TA Technology (Shanghai) Co., Ltd.

Test Report

spacing is set according to FCC KDB Publication 865664. During scan the distance of the probe to the phantom remains unchanged.

After finishing area scan, the field maxima within a range of 2 dB will be ascertained.

- **Zoom Scan**

After the maximum interpolated values were calculated between the points in the cube, the SAR was averaged over the spatial volume (1g or 10g) using a 3D-Spline interpolation algorithm. The 3D-spline is composed of three one-dimensional splines with the “Not a knot” condition (in x, y, and z directions). The volume was then integrated with the trapezoidal algorithm.

- **Spatial Peak Detection**

The procedure for spatial peak SAR evaluation has been implemented and can determine values of masses of 1g and 10g, as well as for user-specific masses. The DASY5 system allows evaluations that combine measured data and robot positions, such as:

- maximum search
- extrapolation
- boundary correction
- peak search for averaged SAR

During a maximum search, global and local maxima searches are automatically performed in 2-D after each Area Scan measurement with at least 6 measurement points. It is based on the evaluation of the local SAR gradient calculated by the Quadratic Shepard’s method. The algorithm will find the global maximum and all local maxima within -2 dB of the global maxima for all SAR distributions.

Extrapolation routines are used to obtain SAR values between the lowest measurement points and the inner phantom surface. The extrapolation distance is determined by the surface detection distance and the probe sensor offset. Several measurements at different distances are necessary for the extrapolation. Extrapolation routines require at least 10 measurement points in 3-D space. They are used in the Zoom Scan to obtain SAR values between the lowest measurement points and the inner phantom surface. The routine uses the modified Quadratic Shepard’s method for extrapolation.

- A Z-axis scan measures the total SAR value at the x-and y-position of the maximum SAR value found during the cube scan. The probe is moved away in z-direction from the bottom of the SAM phantom in 5mm steps.

Table 1: Area and Zoom Scan Resolutions per FCC KDB Publication 865664 D01

Frequency	Maximum Area Scan Resolution (mm) ($\Delta x_{area}, \Delta y_{area}$)	Maximum Zoom Scan Resolution (mm) ($\Delta x_{zoom}, \Delta y_{zoom}$)	Maximum Zoom Scan Spatial Resolution (mm) $\Delta z_{zoom}(n)$	Minimum Zoom Scan Volume (mm) (x,y,z)
≤ 2 GHz	≤ 15	≤ 8	≤ 5	≥ 30
2-3 GHz	≤ 12	≤ 5	≤ 5	≥ 30
3-4 GHz	≤ 12	≤ 5	≤ 4	≥ 28
4-5 GHz	≤ 10	≤ 4	≤ 3	≥ 25
5-6 GHz	≤ 10	≤ 4	≤ 2	≥ 22

2.5. Data Storage and Evaluation

2.5.1. Data Storage

The DASY5 software stores the acquired data from the data acquisition electronics as raw data (in microvolt readings from the probe sensors), together with all necessary software parameters for the data evaluation (probe calibration data, liquid parameters and device frequency and modulation data) in measurement files with the extension “.DAE4”. The software evaluates the desired unit and format for output each time the data is visualized or exported. This allows verification of the complete software setup even after the measurement and allows correction of incorrect parameter settings. For example, if a measurement has been performed with a wrong crest factor parameter in the device setup, the parameter can be corrected afterwards and the data can be re-evaluated.

The measured data can be visualized or exported in different units or formats, depending on the selected probe type ([V/m], [A/m], [°C], [mW/g], [mW/cm²], [dBrel], etc.). Some of these units are not available in certain situations or show meaningless results, e.g., a SAR output in a lossless media will always be zero. Raw data can also be exported to perform the evaluation with other software packages.

2.5.2. Data Evaluation by SEMCAD

The SEMCAD software automatically executes the following procedures to calculate the field units from the microvolt readings at the probe connector. The parameters used in the evaluation are stored in the configuration modules of the software:

Probe parameters:	- Sensitivity	Normi, a _{i0} , a _{i1} , a _{i2}
	- Conversion factor	ConvF _i
	- Diode compression point	Dcp _i
Device parameters:	- Frequency	f
	- Crest factor	cf
Media parameters:	- Conductivity	
	- Density	

These parameters must be set correctly in the software. They can be found in the component documents or they can be imported into the software from the configuration files issued for the DASY5 components. In the direct measuring mode of the multimeter option, the parameters of the actual system setup are used. In the scan visualization and export modes, the parameters stored in the corresponding document files are used.

The first step of the evaluation is a linearization of the filtered input signal to account for the compression characteristics of the detector diode. The compensation depends on the input signal, the diode type and the DC-transmission factor from the diode to the evaluation electronics.

TA Technology (Shanghai) Co., Ltd.
Test Report

Report No.: RXA1307-0093SAR01R3

Page 17 of 225

If the exciting field is pulsed, the crest factor of the signal must be known to correctly compensate for peak power. The formula for each channel can be given as:

$$V_i = U_i + U_i^2 \cdot c f / d c p_i$$

With V_i = compensated signal of channel i (i = x, y, z)

U_i = input signal of channel i (i = x, y, z)

cf = crest factor of exciting field (DASY parameter)

dcp_i = diode compression point (DASY parameter)

From the compensated input signals the primary field data for each channel can be evaluated:

E-field probes: $E_i = (V_i / Norm_i \cdot ConvF)^{1/2}$

H-field probes: $H_i = (V_i)^{1/2} \cdot (a_{i0} + a_{i1} f + a_{i2} f^2) / f$

With V_i = compensated signal of channel i (i = x, y, z)

$Norm_i$ = sensor sensitivity of channel i (i = x, y, z)
[mV/(V/m)²] for E-field Probes

$ConvF$ = sensitivity enhancement in solution

a_{ij} = sensor sensitivity factors for H-field probes

f = carrier frequency [GHz]

E_i = electric field strength of channel i in V/m

H_i = magnetic field strength of channel i in A/m

The RSS value of the field components gives the total field strength (Hermitian magnitude):

$$E_{tot} = (E_x^2 + E_y^2 + E_z^2)^{1/2}$$

The primary field data are used to calculate the derived field units.

$$SAR = (E_{tot})^2 \cdot \sigma / (\rho \cdot 1000)$$

with **SAR** = local specific absorption rate in mW/g

E_{tot} = total field strength in V/m

σ = conductivity in [mho/m] or [Siemens/m]

ρ = equivalent tissue density in g/cm³

Note that the density is normally set to 1 (or 1.06), to account for actual brain density rather than the density of the simulation liquid. The power flow density is calculated assuming the excitation field to be a free space field.

$$P_{pwe} = E_{tot}^2 / 3770 \quad \text{or} \quad P_{pwe} = H_{tot}^2 \cdot 37.7$$

with **P_{pwe}** = equivalent power density of a plane wave in mW/cm²

E_{tot} = total electric field strength in V/m

H_{tot} = total magnetic field strength in A/m

3. Laboratory Environment

Table 2: The Requirements of the Ambient Conditions

Temperature	Min. = 18°C, Max. = 25 °C
Relative humidity	Min. = 30%, Max. = 70%
Ground system resistance	< 0.5 Ω
Ambient noise is checked and found very low and in compliance with requirement of standards.	
Reflection of surrounding objects is minimized and in compliance with requirement of standards.	

4. Tissue-equivalent Liquid

4.1. Tissue-equivalent Liquid Ingredients

The liquid is consisted of water, salt, Glycol, Sugar, Preventol and Cellulose. The liquid has previously been proven to be suited for worst-case. The table 3 and table 4 show the detail solution. It's satisfying the latest tissue dielectric parameters requirements proposed by the OET 65.

Table 3: Composition of the Head Tissue Equivalent Matter

MIXTURE%	FREQUENCY(Brain) 835MHz
Water	41.45
Sugar	56
Salt	1.45
Preventol	0.1
Cellulose	1.0
Dielectric Parameters Target Value	f=835MHz $\epsilon=41.5$ $\sigma=0.9$

MIXTURE%	FREQUENCY(Brain) 1750MHz
Water	55.24
Glycol	44.45
Salt	0.31
Dielectric Parameters Target Value	f=1750MHz $\epsilon=40.1$ $\sigma=1.37$

MIXTURE%	FREQUENCY(Brain) 1900MHz
Water	55.242
Glycol monobutyl	44.452
Salt	0.306
Dielectric Parameters Target Value	f=1900MHz $\epsilon=40.0$ $\sigma=1.40$

MIXTURE%	FREQUENCY(Brain) 2450MHz
Water	62.7
Glycol	36.8
Salt	0.5
Dielectric Parameters Target Value	f=2450MHz $\epsilon=39.20$ $\sigma=1.80$

TA Technology (Shanghai) Co., Ltd.
Test Report

Report No.: RXA1307-0093SAR01R3

Page 20 of 225

Table 4: Composition of the Body Tissue Equivalent Matter

MIXTURE%	FREQUENCY(Body) 835MHz
Water	52.5
Sugar	45
Salt	1.4
Preventol	0.1
Cellulose	1.0
Dielectric Parameters Target Value	f=835MHz $\epsilon=55.2$ $\sigma=0.97$

MIXTURE%	FREQUENCY(Body) 1750MHz
Water	69.91
Glycol	29.97
Salt	0.12
Dielectric Parameters Target Value	f=1750MHz $\epsilon=53.4$ $\sigma=1.49$

MIXTURE%	FREQUENCY (Body) 1900MHz
Water	69.91
Glycol monobutyl	29.96
Salt	0.13
Dielectric Parameters Target Value	f=1900MHz $\epsilon=53.3$ $\sigma=1.52$

MIXTURE%	FREQUENCY(Body) 2450MHz
Water	73.2
Glycol	26.7
Salt	0.1
Dielectric Parameters Target Value	f=2450MHz $\epsilon=52.70$ $\sigma=1.95$

TA Technology (Shanghai) Co., Ltd.
Test Report

4.2. Tissue-equivalent Liquid Properties

Table 5: Dielectric Performance of Tissue Simulating Liquid

Frequency	Test Date	Temp °C	Measured Dielectric Parameters		Target Dielectric Parameters		Limit (Within ±5%)	
			ϵ_r	σ (s/m)	ϵ_r	σ (s/m)	Dev ϵ_r (%)	Dev σ (%)
835MHz (head)	2013-7-20	21.5	41.25	0.916	41.50	0.90	-0.60	1.78
1750MHz (head)	2013-7-17	21.5	39.17	1.398	40.10	1.37	-2.32	2.04
1900MHz (head)	2013-7-18	21.5	38.33	1.451	40.00	1.40	-4.18	3.64
2450MHz (head)	2013-7-17	21.5	38.32	1.880	39.20	1.80	-2.25	4.44
835MHz (body)	2013-7-20	21.5	54.35	1.012	55.20	0.97	-1.54	4.33
1750MHz (body)	2013-7-19	21.5	52.12	1.468	53.40	1.49	-2.40	-1.48
1900MHz (body)	2013-7-18	21.5	52.56	1.524	53.30	1.52	-1.39	0.26
2450MHz (body)	2013-7-19	21.5	51.69	1.903	52.70	1.95	-1.92	-2.41
	2013-8-1	21.5	51.65	1.901	52.70	1.95	-1.99	-2.51

5. System Check

5.1. Description of System Check

The manufacturer calibrates the probes annually. Dielectric parameters of the tissue simulates were measured every day using the dielectric probe kit and the network analyzer. A system check measurement was made following the determination of the dielectric parameters of the simulates, using the dipole validation kit. A power level of 250 mW was supplied to the dipole antenna, which was placed under the flat section of the twin SAM phantom. The system check results (dielectric parameters and SAR values) are given in the table 6 and table 7.

System check results have to be equal or near the values determined during dipole calibration with the relevant liquids and test system ($\pm 10\%$).

System check is performed regularly on all frequency bands where tests are performed with the DASY5 system.

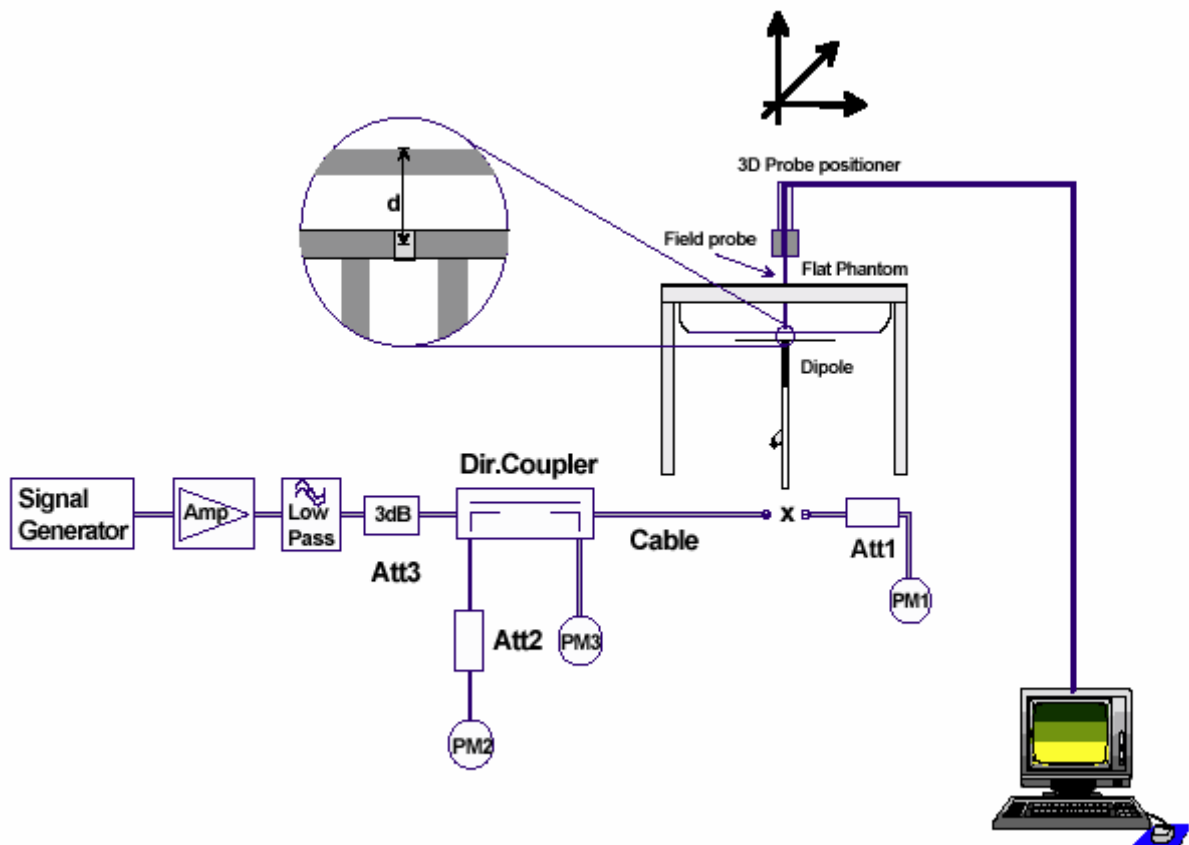

Figure 6 System Check Set-up

TA Technology (Shanghai) Co., Ltd.

Test Report

Justification for Extended SAR Dipole Calibrations

Usage of SAR dipoles calibrated less than 2 years ago but more than 1 year ago were confirmed in maintaining return loss (< - 20 dB, within 20% of prior calibration) and impedance (within 5 ohm from prior calibration) requirements per extended calibrations in KDB 865664 D01:

Dipole D835V2 SN: 4d020				
Head Liquid				
Date of Measurement	Return Loss(dB)	Δ %	Impedance (Ω)	$\Delta\Omega$
8/26/2011	-27.7	/	52.9	/
8/25/2012	-29.1	5.0%	55.0	2.1 Ω
Body Liquid				
Date of Measurement	Return Loss(dB)	Δ %	Impedance (Ω)	$\Delta\Omega$
8/26/2011	-25.1	/	48.7	/
8/25/2012	-24.3	3.2 %	50.6	1.9 Ω

Dipole D1750V2 SN: 1023				
Head Liquid				
Date of Measurement	Return Loss(dB)	Δ %	Impedance (Ω)	$\Delta\Omega$
6/20/2012	-51.7	/	49.9	/
6/19/2013	-50.5	3.2%	51.6	1.7 Ω
Body Liquid				
Date of Measurement	Return Loss(dB)	Δ %	Impedance (Ω)	$\Delta\Omega$
6/20/2012	-27.9	/	46.1	/
6/19/2013	-26.8	3.9%	47.7	1.6 Ω

Dipole D1900V2 SN: 5d060				
Head Liquid				
Date of Measurement	Return Loss(dB)	Δ %	Impedance (Ω)	$\Delta\Omega$
8/31/2011	-22.3	/	52.6	/
8/30/2012	-21.7	2.7%	51.4	1.2 Ω
Body Liquid				
Date of Measurement	Return Loss(dB)	Δ %	Impedance (Ω)	$\Delta\Omega$
8/31/2011	-21.3	/	47.3	/
8/30/2012	-20.9	1.9%	45.9	1.4 Ω

TA Technology (Shanghai) Co., Ltd.
Test Report

Report No.: RXA1307-0093SAR01R3

Page 24 of 225

Dipole D2450V2 SN: 786				
Head Liquid				
Date of Measurement	Return Loss(dB)	Δ %	Impedance (Ω)	$\Delta\Omega$
8/29/2011	-25.5	/	55.0	/
8/28/2012	-26.8	5.1%	56.5	1.5 Ω
Body Liquid				
Date of Measurement	Return Loss(dB)	Δ %	Impedance (Ω)	$\Delta\Omega$
8/29/2011	-29.0	/	50.4	/
8/28/2012	-29.9	3.1%	52.1	1.7 Ω

TA Technology (Shanghai) Co., Ltd.

Test Report

5.2. System Check Results

Table 6: System Check in Head Tissue Simulating Liquid

Frequency	Test Date	Dielectric Parameters		Temp	250mW Measured SAR _{1g}	1W Normalized SAR _{1g}	1W Target SAR _{1g}	Limit (±10% Deviation)
		ϵ_r	σ (s/m)	(°C)	(W/kg)			
835MHz	2013-7-20	41.25	0.916	21.5	2.44	9.76	9.34	4.50
1750MHz	2013-7-17	39.17	1.398	21.5	8.45	33.80	36.10	-6.37
1900MHz	2013-7-18	38.33	1.451	21.5	9.48	37.92	40.30	-5.91
2450MHz	2013-7-17	38.32	1.880	21.5	13.70	54.80	53.80	1.86

Note: 1. The graph results see ANNEX B.
 2. Target Values used derive from the calibration certificate

Table 7: System Check in Body Tissue Simulating Liquid

Frequency	Test Date	Dielectric Parameters		Temp	250mW Measured SAR _{1g}	1W Normalized SAR _{1g}	1W Target SAR _{1g}	Limit (±10% Deviation)
		ϵ_r	σ (s/m)	(°C)	(W/kg)			
835MHz	2013-7-20	54.35	1.012	21.5	2.41	9.64	9.46	1.90
1750MHz	2013-7-19	52.12	1.468	21.5	9.24	36.96	38.5	-4.00
1900MHz	2013-7-18	52.56	1.524	21.5	9.93	39.72	41.70	-4.75
2450MHz	2013-7-19	51.69	1.903	21.5	12.50	50.00	51.70	-3.29
	2013-8-1	51.65	1.901	21.5	12.40	49.60	51.70	-4.06

Note: 1. The graph results see ANNEX B.
 2. Target Values used derive from the calibration certificate.

6. Operational Conditions during Test

6.1. General Description of Test Procedures

A communication link is set up with a System Simulator (SS) by air link, and a call is established. The EUT is commanded to operate at maximum transmitting power.

Connection to the EUT is established via air interface with E5515C, and the EUT is set to maximum output power by E5515C. The EUT battery must be fully charged and checked periodically during the test to ascertain uniform power output. The antenna connected to the output of the base station simulator shall be placed at least 50 cm away from the EUT. The signal transmitted by the simulator to the antenna feeding point shall be lower than the output power level of the EUT by at least 30 dB.

6.2. Test Positions

6.2.1. Against Phantom Head

Measurements were made in "cheek" and "tilt" positions on both the left hand and right hand sides of the phantom.

The positions used in the measurements were according to IEEE 1528 - 2003 "IEEE Recommended Practice for Determining the Peak Spatial-Average Specific Absorption Rate(SAR) in the Human Head from Wireless Communications Devices: Measurement Techniques".

6.2.2. Body Worn Configuration

Body-worn operating configurations should be tested with the belt-clips and holsters attached to the device and positioned against a flat phantom in normal use configurations. Devices with a headset output should be tested with a headset connected to the device.

Based upon KDB941225 D06 with a form factor > 9 cm x 5 cm, when the antenna-to-edge distance is greater than 2.5cm, such position does not need to be tested. The distance between the device and the phantom was kept 10mm of wireless routers, and the distance between the device and the phantom was kept 15mm for body worn.

Body-worn operating configurations are tested with the belt-clips and holsters attached to the device and positioned against a flat phantom in a normal use configuration. Per FCC KDB Publication 648474 D04, Body-worn accessory exposure is typically related to voice mode operations when handsets are carried in body-worn accessories. The body-worn accessory procedures in FCC KDB Publication 447498 D01 should be used to test for body-worn accessory SAR compliance, without a headset connected to it. This enables the test results for such configuration to be compatible with that required for hotspot mode when the body-worn accessory test separation distance is greater than or equal to that required for hotspot mode, when applicable. When the reported SAR for a body-worn accessory, measured without a headset connected to the handset, is > 1.2 W/kg, the highest reported SAR configuration for that wireless mode and frequency band should be repeated for that body-worn accessory with a headset attached to the handset.

Accessories for Body-worn operation configurations are divided into two categories: those that do not contain metallic components and those that do contain metallic components. When multiple accessories that do not contain metallic components are supplied with the device, the device is tested with only the accessory that dictates the closest spacing to the body. Then multiple accessories that contain metallic components are tested with the device with each accessory. If multiple accessories share an identical metallic component (i.e. the same metallic belt-clip used with different holsters with no other metallic components) only the accessory that dictates the closest spacing to the body is tested.

Body-worn accessories may not always be supplied or available as options for some devices intended to be authorized for body-worn use. In this case, a test configuration with a separation distance between the back of the device and the flat phantom is used. Test position spacing was documented. Transmitters that are designed to operate in front of a person's face, as in push-to-talk configurations, are tested for SAR compliance with the front of the device positioned to face the flat phantom in head fluid. For devices that are carried next to the body such as a shoulder, waist or chest-worn transmitters, SAR compliance is tested with the accessories, including headsets and microphones, attached to the device and positioned against a flat phantom in a normal use configuration.

6.3. Measurement Variability

Per FCC KDB Publication 865664 D01, SAR measurement variability was assessed for each frequency band, which was determined by the SAR probe calibration point and tissue-equivalent medium used for the device measurements. When both head and body tissue-equivalent media were required for SAR measurements in a frequency band, the variability measurement procedures were applied to the tissue medium with the highest measured SAR, using the highest measured SAR configuration for that tissue-equivalent medium. These additional measurements were repeated after the completion of all measurements requiring the same head or body tissue-equivalent medium in a frequency band. The test device was returned to ambient conditions (normal room temperature) with the battery fully charged before it was re-mounted on the device holder for the repeated measurement(s) to minimize any unexpected variations in the repeated results.

SAR Measurement Variability was assessed using the following procedures for each frequency band:

- 1) When the original highest measured SAR is ≥ 0.80 W/kg, the measurement was repeated once.
- 2) A second repeated measurement was performed only if the ratio of largest to smallest SAR for the original and first repeated measurements was > 1.20 or when the original or repeated measurement was ≥ 1.45 W/kg (~ 10% from the 1-g SAR limit).
- 3) A third repeated measurement was performed only if the original, first or second repeated measurement was ≥ 1.5 W/kg and the ratio of largest to smallest SAR for the original, first and second repeated measurements is > 1.20 .
- 4) Repeated measurements are not required when the original highest measured SAR is < 0.80 W/kg

6.4. Test Configuration

6.4.1. GSM Test Configuration

SAR tests for GSM 850 and GSM 1900, a communication link is set up with a System Simulator (SS) by air link. Using E5515C the power level is set to “5” for GSM 850, set to “0” for GSM 1900. Since the GPRS class is 12 for this EUT, it has at most 4 timeslots in uplink and at most 4 timeslots in downlink, the maximum total timeslots is 5. The EGPRS class is 12 for this EUT, it has at most 4 timeslots in uplink and at most 4 timeslots in downlink, the maximum total timeslots is 5.

When SAR tests for EGPRS mode is necessary, GMSK modulation should be used to minimize SAR measurement error due to higher peak-to-average power (PAR) ratios inherent in 8-PSK.

According to specification 3GPP TS 51.010, the maximum power of the GSM can do the power reduction for the multi-slot. The allowed power reduction in the multi-slot configuration is as following:

Output power of reductions:

Table 8: The allowed power reduction in the multi-slot configuration

Number of timeslots in uplink assignment	Permissible nominal reduction of maximum output power,(dB)
1	0
2	0 to 3,0
3	1,8 to 4,8
4	3,0 to 6,0

6.4.2. UMTS Test Configuration

6.4.2.1. Output power Verification

Maximum output power is verified on the High, Middle and Low channel according to the procedures described in section 5.2 of 3GPP TS 34. 121, using the appropriate RMC or AMR with TPC(transmit power control) set to all up bits for WCDMA/HSDPA or applying the required inner loop power control procedures to the maximum output power while HSUPA is active. Results for all applicable physical channel configuration (DPCCH, DPDCH_n and spreading codes, HSDPA, HSPA) should be tabulated in the SAR report. All configuration that are not supported by the DUT or can not be measured due to technical or equipment limitations should be clearly identified

6.4.2.2. Head SAR Measurements

SAR for head exposure configurations in voice mode is measured using a 12.2kbps RMC with TPC bits configured to all up bits. SAR in AMR configurations is not required when the maximum average output of each RF channel for 12.2kbps AMR is less than 1/4 dB higher than that measured in 12.2 kbps RMC. Otherwise, SAR is measured on the maximum output channel in 12.2kbps AMR with a 3.4 kbps SRB(Signaling radio bearer) using the exposure configuration that results in the highest SAR in 12.2kbps RMC for that RF channel.

6.4.2.3. Body SAR Measurements

SAR for body exposure configurations in voice and data modes is measured using 12.2kbps RMC with TPC bits configured to all up bits. SAR for other spreading codes and multiple DPDCH_n, when supported by the DUT, are not required when the maximum average output of each RF channel, for each spreading code and DPDCH_n configuration, are less than 1/4 dB higher than those measured in 12.2kbps RMC. Otherwise, SAR is measured on the maximum output channel with an applicable RMC configuration for the corresponding spreading code or DPDCH_n using the exposure configuration that results in the highest SAR with 12.2 kbps RMC. When more than 2 DPDCH_n are supported by the DUT, it may be necessary to configure additional DPDCH_n for a DUT using FTM (Factory Test Mode) or other chipset based test approaches with parameters similar to those used in 384 kbps and 768 kbps RMC.

6.4.3. HSDPA Test Configuration

SAR for body exposure configurations is measured according to the 'Body SAR Measurements' procedures of that section. In addition, body SAR is also measured for HSDPA when the maximum average output of each RF channel with HSDPA active is at least ¼ dB higher than that measured without HSDPA using 12.2 kbps RMC or the maximum SAR for 12.2 kbps RMC is above 75% of the SAR limit. Body SAR for HSDPA is measured using an FRC with H-Set 1 in Sub-test 1 and a 12.2 kbps RMC configured in Test Loop Mode 1, using the highest body SAR configuration in 12.2 kbps RMC without HSDPA.

HSDPA should be configured according to the UE category of a test device. The number of HSDSCH/ HS-PDSCHs, HARQ processes, minimum inter-TTI interval, transport block sizes and RV coding sequence are defined by the H-set. To maintain a consistent test configuration and stable transmission conditions, QPSK is used in the H-set for SAR testing. HS-DPCCH should be configured with a CQI feedback cycle of 4 ms with a CQI repetition factor of 2 to maintain a constant rate of active CQI slots. DPCCH and DPDCH gain factors (β_c , β_d), and HS-DPCCH power offset parameters (Δ_{ACK} , Δ_{NACK} , Δ_{CQI}) should be set according to values indicated in the Table below. The CQI value is determined by the UE category, transport block size, number of HS-PDSCHs and modulation used in the H-set.

TA Technology (Shanghai) Co., Ltd.

Test Report

Table 9: Subtests for UMTS Release 5 HSDPA

Sub-set	β_c	β_d	β_d (SF)	β_c/β_d	β_{hs} (note 1, note 2)	CM(dB) (note 3)	MPR(dB)
1	2/15	15/15	64	2/15	4/15	0.0	0.0
2	12/15 (note 4)	15/15 (note 4)	64	12/15 (note 4)	24/15	1.0	0.0
3	15/15	8/15	64	15/8	30/15	1.5	0.5
4	15/15	4/15	64	15/4	30/15	1.5	0.5

Note1: Δ_{ACK} , Δ_{NACK} and $\Delta_{CQI} = 8 \Leftrightarrow A_{hs} = \beta_{hs}/\beta_c = 30/15 \Leftrightarrow \beta_{hs} = 30/15 * \beta_c$

Note2: For the HS-DPCCH power mask requirement test in clause 5.2C, 5.7A, and the Error Vector Magnitude (EVM) with HS-DPCCH test in clause 5.13.1.A, and HSDPA EVM with phase discontinuity in clause 5.13.1AA, Δ_{ACK} and $\Delta_{NACK} = 8$ ($A_{hs} = 30/15$) with $\beta_{hs} = 30/15 * \beta_c$, and $\Delta_{CQI} = 7$ ($A_{hs} = 24/15$) with $\beta_{hs} = 24/15 * \beta_c$.

Note3: CM=1 for $\beta_c/\beta_d = 12/15$, $\beta_{hs}/\beta_c = 24/15$. For all other combinations of DPDCH, DPCCH and HS-DPCCH the MPR is based on the relative CM difference. This is applicable for only UEs that support HSDPA in release 6 and later releases.

Note 4: For subtest 2 the β_c/β_d ratio of 12/15 for the TFC during the measurement period (TF1, TF0) is achieved by setting the signaled gain factors for the reference TFC (TFC1, TF1) to $\beta_c = 11/15$ and $\beta_d = 15/15$.

Table 10: Settings of required H-Set 1 QPSK in HSDPA mode

Parameter	Unit	Value
Nominal Avg. Inf. Bit Rate	kbps	534
Inter-TTI Distance	TTI's	3
Number of HARQ Processes	Processes	2
Information Bit Payload (N_{INF})	Bits	3202
Number Code Blocks	Blocks	1
Binary Channel Bits Per TTI	Bits	4800
Total Available SML's in UE	SML's	19200
Number of SML's per HARQ Proc.	SML's	9600
Coding Rate	/	0.67
Number of Physical Channel Codes	Codes	5
Modulation	/	QPSK

6.4.3.1. DC-HSDPA Test Configuration

body SAR is also measured for DC-HSDPA when the maximum average output of each RF channel with DC-HSDPA active is at least 1/4 dB higher than that measured without HSDPA using 12.2kbps RMC or the maximum SAR 12.2kbps RMC is above 75% of the SAR limit. Body SAR for DC-HSDPA is measured using the highest body SAR configuration in 12.2 kbps RMC without HSDPA.

Configure DC-HSDPA parameters for base station

a) Set up the HSDPA RB Test Mode Parameters

- RB Test HS-DSCH Configuration Type = User Defined
- RB Test User Defined HS-DSCH MAC entity = MAC-ehs (Note 1)
- RB Test User Defined HARQ Processes = 6 (Note 2)
- RB Test User Defined UE IR Buffer Allocation = Implicit
- RB Test User Defined DC-HSDPA State = On
- RB Test Mode DC-HSDPA DPCH Loopback State = On

b) Set up the Serving Cell Parameters

- RB Test User Defined 64QAM State =On
- RB Test User Defined Active HS-PDSCHs =15
- RB Test User Def Transport Block Size Index =62
- RB Test User Defined Modulation Type =64QAM
- RB Test User Defined Inter-TTI Interval =1

c) Set up the Secondary Serving Cell Parameters

- RB Test User Def Secondary Cell 64QAM State =On
- RBTM User Def Sec Cell Active HS-PDSCHs = 15
- RBTM User Def Sec Cell TB Size Index = 62
- RBTM User Def Sec Cell Modulation Type =64QAM
- RBTM User Def Sec Cell Inter-TTI Interval = 1

d) Set the HSDPA Conn DL Channel Levels

- HSDPA Cell 1 Connected CPICH Level = -8
- HSDPA Cell 1 Connected P-CCPCH/SCH Level = -20
- HSDPA Cell 1 Connected PICH Level = off
- HSDPA Cell 1 Connected DPCH Level = -30
- HSDPA Cell 1 Connected HS-PDSCH Level (Sum) = -1 dBm
- HSDPA Cell 1 Connected HS-SCCH 1 to 4 Level = -20,-20,off,off
- Secondary Cell HSDPA Conn CPICH Level = -8
- Secondary Cell HSDPA Conn PCCPCH/SCH Level = -20
- Secondary Cell HSDPA Conn PICH Level = off
- Secondary Cell HSDPA Conn HS-PDSCHs Lvl (Sum) = -1 dBm
- Secondary Cell HSDPA Conn HS-SCCH 1 to 4 Level = -20,-20,off,off

TA Technology (Shanghai) Co., Ltd.

Test Report

Table 11: HS-DSCH UE category

Table 5.1a: FDD HS-DSCH physical layer categories

HS-DSCH category	Maximum number of HS-DSCH codes received	Minimum inter-TTI interval	Maximum number of bits of an HS-DSCH transport block received within an HS-DSCH TTI NOTE 1	Total number of soft channel bits	Supported modulations without MIMO operation or dual cell operation	Supported modulations with MIMO operation and without dual cell operation	Supported modulations with dual cell operation
Category 1	5	3	7298	19200	QPSK, 16QAM	Not applicable (MIMO not supported)	Not applicable (dual cell operation not supported)
Category 2	5	3	7298	28800			
Category 3	5	2	7298	28800			
Category 4	5	2	7298	38400			
Category 5	5	1	7298	57600			
Category 6	5	1	7298	67200			
Category 7	10	1	14411	115200			
Category 8	10	1	14411	134400			
Category 9	15	1	20251	172800			
Category 10	15	1	27952	172800			
Category 11	5	2	3630	14400	QPSK		
Category 12	5	1	3630	28800	QPSK, 16QAM, 64QAM		
Category 13	15	1	35280	259200			
Category 14	15	1	42192	259200	QPSK, 16QAM		
Category 15	15	1	23370	345600	QPSK, 16QAM		
Category 16	15	1	27952	345600	QPSK, 16QAM		
Category 17 NOTE 2	15	1	35280	259200	QPSK, 16QAM, 64QAM	-	
			23370	345600	-	QPSK, 16QAM	
Category 18 NOTE 3	15	1	42192	259200	QPSK, 16QAM, 64QAM	-	
			27952	345600	-	QPSK, 16QAM	
Category 19	15	1	35280	518400	QPSK, 16QAM, 64QAM		
Category 20	15	1	42192	518400	QPSK, 16QAM, 64QAM		
Category 21	15	1	23370	345600	-	-	QPSK, 16QAM
Category 22	15	1	27952	345600			
Category 23	15	1	35280	518400			
Category 24	15	1	42192	518400			

6.4.3.2. HSUPA Test Configuration

Body SAR is also measured for HSPA when the maximum average output of each RF channel with HSPA active is at least ¼ dB higher than that measured without HSPA using 12.2 kbps RMC or the maximum SAR for 12.2 kbps RMC is above 75% of the SAR limit. Body SAR for HSPA is measured with E-DCH Sub-test 5, using H-Set 1 and QPSK for FRC and a 12.2 kbps RMC configured in Test Loop Mode 1 with power control algorithm 2, according to the highest body SAR configuration in 12.2 kbps RMC without HSPA.

Due to inner loop power control requirements in HSPA, a commercial communication test set should be used for the output power and SAR tests. The 12.2 kbps RMC, FRC H-set 1 and E-DCH configurations for HSPA should be configured according to the β values indicated below as well as other applicable procedures described in the 'WCDMA Handset' and 'Release 5 HSDPA Data Devices' sections of 3 G device.

TA Technology (Shanghai) Co., Ltd.

Test Report

Table 12: Sub-Test 5 Setup for Release 6 HSUPA

Sub-set	β_c	β_d	β_d (SF)	β_c/β_d	$\beta_{hs}^{(1)}$	β_{ec}	β_{ed}	β_{ed} (SF)	β_{ed} (codes)	CM ⁽²⁾ (dB)	MPR (dB)	AG ⁽⁴⁾ Index	E-TFCI
1	11/15 ⁽³⁾	15/15 ⁽³⁾	64	11/15 ⁽³⁾	22/15	209/225	1039/225	4	1	1.0	0.0	20	75
2	6/15	15/15	64	6/15	12/15	12/15	94/75	4	1	3.0	2.0	12	67
3	15/15	9/15	64	15/9	30/15	30/15	β_{ed1} :47/15 β_{ed2} :47/15	4	2	2.0	1.0	15	92
4	2/15	15/15	64	2/15	4/15	2/15	56/75	4	1	3.0	2.0	17	71
5	15/15 ⁽⁴⁾	15/15 ⁽⁴⁾	64	15/15 ⁽⁴⁾	30/15	24/15	134/15	4	1	1.0	0.0	21	81

Note 1: Δ_{ACK} , Δ_{NACK} and $\Delta_{CQI} = 8 \Leftrightarrow A_{hs} = \beta_{hs}/\beta_c = 30/15 \Leftrightarrow \beta_{hs} = 30/15 * \beta_c$.

Note 2: CM = 1 for $\beta_c/\beta_d = 12/15$, $\beta_{hs}/\beta_c = 24/15$. For all other combinations of DPDCH, DPCCH, HS-DPCCH, E-DPDCH and E-DPCCH the MPR is based on the relative CM difference.

Note 3: For subtest 1 the β_c/β_d ratio of 11/15 for the TFC during the measurement period (TF1, TF0) is achieved by setting the signaled gain factors for the reference TFC (TF1, TF1) to $\beta_c = 10/15$ and $\beta_d = 15/15$.

Note 4: For subtest 5 the β_c/β_d ratio of 15/15 for the TFC during the measurement period (TF1, TF0) is achieved by setting the signaled gain factors for the reference TFC (TF1, TF1) to $\beta_c = 14/15$ and $\beta_d = 15/15$.

Note 5: Testing UE using E-DPDCH Physical Layer category 1 Sub-test 3 is not required according to TS 25.306 Figure 5.1g.

Note 6: β_{ed} can not be set directly; it is set by Absolute Grant Value.

Table 13: HSUPA UE category

UE E-DCH Category	Maximum E-DCH Codes Transmitted	Number of HARQ Processes	E-DCH TTI (ms)	Minimum Spreading Factor	Maximum E-DCH Transport Block Bits	Max Rate (Mbps)
1	1	4	10	4	7110	0.7296
2	2	8	2	4	2798	1.4592
	2	4	10	4	14484	
3	2	4	10	4	14484	1.4592
4	2	8	2	2	5772	2.9185
	2	4	10	2	20000	2.00
5	2	4	10	2	20000	2.00
6 (No DPDCH)	4	8	2	2 SF2 & 2 SF4	11484	5.76
	4	4	10		20000	2.00
7 (No DPDCH)	4	8	2	2 SF2 & 2 SF4	22996	?
	4	4	10		20000	?

NOTE: When 4 codes are transmitted in parallel, two codes shall be transmitted with SF2 and two with SF4.

UE Categories 1 to 6 supports QPSK only. UE Category 7 supports QPSK and 16QAM. (TS25.306-7.3.0)

6.4.4. WIFI Test Configuration

For WLAN SAR testing, WLAN engineering testing software installed on the DUT can provide continuous transmitting RF signal. The Tx power is set to 23 for 802.11 b mode, set to 19 for 802.11 g mode, set to 19 for 802.11 n mode by software, This RF signal utilized in SAR measurement has almost 100% duty cycle and its crest factor is 1.

For the 802.11b/g/n SAR tests, a communication link is set up with the test mode software for WIFI mode test. During the test, at the each test frequency channel, the EUT is operated at the RF continuous emission mode. Each channel should be tested at the highest power rate.

802.11b/g/n operating modes are tested independently according to the service requirements in each frequency band. 802.11b/g/n modes are tested on the maximum average output channel;

SAR is not required for 802.11g/n channels when the maximum average output power is less than 0.25dB higher than that measured on the corresponding 802.11b channels.

6.4.5. BT Test Configuration

For BT SAR testing, BT engineering testing software installed on the EUT can provide continuous transmitting RF signal with maximum output power. And the CBT control the EUT operating at 2402 MHz with hopping off, and data rate set for 3DH5. This RF signal utilized in SAR measurement has Almost 100% duty cycle and its crest factor is 1.

TA Technology (Shanghai) Co., Ltd.

Test Report

7. Test Results

7.1. Conducted Power Results

Table 14: Conducted Power Measurement Results

GSM 850		Burst Conducted Power(dBm)				Average power(dBm)		
		Channel 128	Channel 190	Channel 251		Channel 128	Channel 190	Channel 251
GSM		31.83	31.98	32.00	-9.03dB	22.8	22.95	22.97
GPRS (GMSK)	1Txslot	31.84	31.99	32.01	-9.03dB	22.81	22.96	22.98
	2Txslots	29.98	30.12	30.14	-6.02dB	23.96	24.10	24.12
	3Txslots	28.53	28.67	28.7	-4.26dB	24.27	24.41	24.44
	4Txslots	27.07	27.22	27.24	-3.01dB	24.06	24.21	24.23
EGPRS (GMSK)	1Txslot	31.84	31.99	32.01	-9.03dB	22.81	22.96	22.98
	2Txslots	29.98	30.12	30.14	-6.02dB	23.96	24.10	24.12
	3Txslots	28.53	28.67	28.7	-4.26dB	24.27	24.41	24.44
	4Txslots	27.07	27.22	27.24	-3.01dB	24.06	24.21	24.23
EGPRS (8PSK)	1Txslot	25.34	25.36	25.50	-9.03dB	16.31	16.33	16.47
	2Txslots	23.06	23.10	23.24	-6.02dB	17.04	17.08	17.22
	3Txslots	20.77	20.85	21.02	-4.26dB	16.51	16.59	16.76
	4Txslots	19.01	19.04	19.20	-3.01dB	16.00	16.03	16.19
GSM 1900		Burst Conducted Power(dBm)				Average power(dBm)		
		Channel 512	Channel 661	Channel 810		Channel 512	Channel 661	Channel 810
GSM		29.41	29.64	29.76	-9.03dB	20.38	20.61	20.73
GPRS (GMSK)	1Txslot	29.41	29.65	29.76	-9.03dB	20.38	20.62	20.73
	2Txslots	28.00	28.19	28.25	-6.02dB	21.98	22.17	22.23
	3Txslots	26.13	26.29	26.33	-4.26dB	21.87	22.03	22.07
	4Txslots	24.69	24.82	24.86	-3.01dB	21.68	21.81	21.85
EGPRS (GMSK)	1Txslot	29.41	29.65	29.76	-9.03dB	20.38	20.62	20.73
	2Txslots	28.00	28.19	28.25	-6.02dB	21.98	22.17	22.23
	3Txslots	26.13	26.29	26.33	-4.26dB	21.87	22.03	22.07
	4Txslots	24.69	24.82	24.86	-3.01dB	21.68	21.81	21.85
EGPRS (8PSK)	1Txslot	25.84	25.95	25.86	-9.03	16.81	16.92	16.83
	2Txslots	23.69	23.76	23.79	-6.02	17.67	17.74	17.77

TA Technology (Shanghai) Co., Ltd.

Test Report

Report No.: RXA1307-0093SAR01R3

Page 36 of 225

	3Txslots	21.54	21.49	21.46	-4.26	17.28	17.23	17.20
	4Txslots	19.65	19.80	19.84	-3.01	16.64	16.79	16.83

Note:

1) Division Factors

To average the power, the division factor is as follows:

1Txslot = 1 transmit time slot out of 8 time slots

=> conducted power divided by (8/1) => -9.03 dB

2Txslots = 2 transmit time slots out of 8 time slots

=> conducted power divided by (8/2) => -6.02 dB

3Txslots = 3 transmit time slots out of 8 time slots

=> conducted power divided by (8/3) => -4.26 dB

4Txslots = 4 transmit time slots out of 8 time slots

=> conducted power divided by (8/4) => -3.01 dB

2) Average power numbers

The maximum power numbers are marks in bold.

UMTS Band V		Conducted Power (dBm)		
		Channel 4132	Channel 4183	Channel 4233
RMC	12.2kbps RMC	21.98	22.11	21.86
	64kbps RMC	21.98	22.16	21.85
	144kbps RMC	21.97	22.11	21.88
	384kbps RMC	21.99	22.14	21.9
HSDPA	Sub - Test 1	21.22	21.35	21.09
	Sub - Test 2	21.21	21.31	21.04
	Sub - Test 3	20.75	20.87	20.55
	Sub - Test 4	20.73	20.85	20.54
DC-HSDPA	Sub - Test 1	21.17	21.34	21.07
	Sub - Test 2	21.15	21.29	21.01
	Sub - Test 3	20.72	20.81	20.52
	Sub - Test 4	20.70	20.83	20.55
HSUPA	Sub - Test 1	19.56	19.49	19.59
	Sub - Test 2	17.89	17.97	17.92
	Sub - Test 3	18.67	18.78	18.67
	Sub - Test 4	17.95	18.01	18.04
	Sub - Test 5	19.79	19.97	19.87

TA Technology (Shanghai) Co., Ltd.
Test Report

Report No.: RXA1307-0093SAR01R3

Page 37 of 225

Hotspot Closed

UMTS Band II		Conducted Power (dBm)		
		Channel 9262	Channel 9400	Channel 9538
RMC	12.2kbps RMC	22.28	22.32	22.05
	64kbps RMC	22.26	22.34	22.02
	144kbps RMC	22.33	22.35	22.03
	384kbps RMC	22.31	22.39	22.06
HSDPA	Sub - Test 1	21.41	21.39	21.21
	Sub - Test 2	21.38	21.40	21.23
	Sub - Test 3	20.85	20.89	20.74
	Sub - Test 4	20.83	20.85	20.73
DC-HSDPA	Sub - Test 1	21.36	21.35	21.19
	Sub - Test 2	21.32	21.41	21.21
	Sub - Test 3	20.81	20.84	20.76
	Sub - Test 4	20.82	20.82	20.72
HSUPA	Sub - Test 1	20.13	20.23	20.18
	Sub - Test 2	19.24	19.08	19.08
	Sub - Test 3	19.85	19.79	19.58
	Sub - Test 4	19.28	19.09	19.12
	Sub - Test 5	20.22	20.34	20.32
UMTS Band IV		Conducted Power (dBm)		
		Channel 1312	Channel 1413	Channel 1513
RMC	12.2kbps RMC	22.43	22.65	22.32
	64kbps RMC	22.44	22.7	22.35
	144kbps RMC	22.49	22.67	22.31
	384kbps RMC	22.49	22.7	22.41
HSDPA	Sub - Test 1	21.62	21.82	21.58
	Sub - Test 2	21.57	21.78	21.50
	Sub - Test 3	21.07	21.29	21.02
	Sub - Test 4	21.05	21.27	21.03
DC-HSDPA	Sub - Test 1	21.64	21.80	21.54
	Sub - Test 2	21.53	21.72	21.52
	Sub - Test 3	21.06	21.25	21.03

TA Technology (Shanghai) Co., Ltd.
Test Report

Report No.: RXA1307-0093SAR01R3

Page 38 of 225

	Sub - Test 4	21.02	21.26	21.02
HSUPA	Sub - Test 1	20.62	20.61	20.64
	Sub - Test 2	19.51	19.57	19.71
	Sub - Test 3	20.02	20.11	20.08
	Sub - Test 4	19.56	19.65	19.68
	Sub - Test 5	20.72	20.68	20.68

BT Channel	Ch 0 2402 MHz	Ch 39 2441 MHz	Ch 78 2480 MHz
Average Conducted Output Power(dBm)	10.72	10.64	10.45
Peak Conducted Output Power(dBm)	11.14	11.07	10.90

WIFI Mode	Channel	Data rate (Mbps)	Peak Power (dBm)	AV Power (dBm)
11b	1	1	23.77	21.64
		2	23.81	21.62
		5.5	24.81	22.14
		11	24.50	21.67
	6	1	24.07	22.51
		2	24.25	22.41
		5.5	25.15	22.92
		11	25.02	22.33
	11	1	24.32	22.43
		2	24.47	22.44
		5.5	25.31	22.90
		11	25.16	22.32
11g	1	6	20.03	16.10
		9	19.87	15.94
		12	19.98	15.77
		18	19.99	15.39
		24	19.89	15.14
		36	19.85	14.76

TA Technology (Shanghai) Co., Ltd.
Test Report

Report No.: RXA1307-0093SAR01R3

Page 39 of 225

		48	19.82	14.40	
		54	19.86	14.26	
	6	6	21.04	16.65	
		9	20.68	16.31	
		12	20.88	16.20	
		18	20.77	15.96	
		24	20.69	15.72	
		36	20.56	15.34	
		48	20.79	14.96	
		54	20.90	14.82	
		11	6	21.79	16.40
			9	21.56	16.23
	12		21.59	16.15	
	18		21.72	15.89	
	24		21.63	15.63	
	36		21.47	15.25	
	48		21.65	14.63	
	54		21.52	14.50	
	11n HT20	1	MCS0	21.53	16.07
MCS1			21.22	15.78	
MCS2			21.05	15.53	
MCS3			21.24	15.29	
MCS4			21.04	14.75	
MCS5			21.17	14.45	
MCS6			21.33	14.32	
MCS7		21.42	14.18		
6		MCS0	21.81	16.65	
		MCS1	21.53	16.20	
		MCS2	21.58	15.96	
		MCS3	21.70	15.72	
		MCS4	21.62	15.35	
		MCS5	21.39	15.01	
		MCS6	21.50	14.89	
	MCS7	21.52	14.55		

TA Technology (Shanghai) Co., Ltd.
Test Report

Report No.: RXA1307-0093SAR01R3

Page 40 of 225

	11	MCS0	22.70	16.40
		MCS1	21.61	16.09
		MCS2	21.73	15.87
		MCS3	21.93	15.6
		MCS4	21.69	15.25
		MCS5	21.75	14.94
		MCS6	21.97	14.80
		MCS7	22.02	14.63
11n HT40	3	MCS0	15.71	12.71
		MCS1	15.37	12.24
		MCS2	15.67	11.25
		MCS3	15.46	11.29
		MCS4	15.41	10.80
		MCS5	15.36	10.45
		MCS6	15.53	10.25
		MCS7	15.46	10.18
	6	MCS0	16.28	12.77
		MCS1	16.21	12.34
		MCS2	16.11	11.96
		MCS3	16.03	11.67
		MCS4	15.73	11.16
		MCS5	15.94	10.77
		MCS6	15.82	10.59
		MCS7	15.70	10.50
	9	MCS0	17.12	13.01
		MCS1	17.04	12.56
		MCS2	17.01	12.15
		MCS3	16.56	11.83
		MCS4	16.41	11.35
		MCS5	16.55	10.95
		MCS6	16.30	10.54
		MCS7	16.47	10.42

TA Technology (Shanghai) Co., Ltd.
Test Report

Report No.: RXA1307-0093SAR01R3

Page 41 of 225

Hotspot Open

UMTS Band II		Conducted Power (dBm)		
		Channel 9262	Channel 9400	Channel 9538
RMC	12.2kbps RMC	20.67	20.72	20.54
	64kbps RMC	20.68	20.74	20.52
	144kbps RMC	20.72	20.71	20.49
	384kbps RMC	20.70	20.70	20.51
HSDPA	Sub - Test 1	20.72	20.75	20.60
	Sub - Test 2	20.71	20.74	20.58
	Sub - Test 3	20.25	20.27	20.08
	Sub - Test 4	20.21	20.25	20.07
DC-HSDPA	Sub - Test 1	20.56	20.53	20.56
	Sub - Test 2	20.51	20.52	20.48
	Sub - Test 3	20.21	20.22	20.06
	Sub - Test 4	20.25	20.21	20.09
HSUPA	Sub - Test 1	18.98	18.87	18.97
	Sub - Test 2	17.78	17.76	17.69
	Sub - Test 3	18.53	18.47	18.53
	Sub - Test 4	17.84	17.83	17.81
	Sub - Test 5	19.71	19.74	19.72
UMTS Band IV		Conducted Power (dBm)		
		Channel 1312	Channel 1413	Channel 1513
RMC	12.2kbps RMC	20.97	21.10	20.82
	64kbps RMC	20.90	21.12	20.83
	144kbps RMC	20.92	21.16	20.83
	384kbps RMC	20.94	21.14	20.84
HSDPA	Sub - Test 1	21.03	21.15	20.89
	Sub - Test 2	21.02	21.13	20.87
	Sub - Test 3	20.61	20.73	20.45
	Sub - Test 4	20.58	20.72	20.41
DC-HSDPA	Sub - Test 1	21.01	21.12	20.84
	Sub - Test 2	20.95	21.11	20.82
	Sub - Test 3	20.58	20.70	20.41
	Sub - Test 4	20.51	20.73	20.34
HSUPA	Sub - Test 1	20.12	20.01	20.07
	Sub - Test 2	19.29	19.26	19.27
	Sub - Test 3	19.00	20.73	20.45
	Sub - Test 4	19.31	19.35	19.39
	Sub - Test 5	20.18	20.17	20.21

7.2. Standalone SAR Test Exclusion Considerations

Per FCC KDB 447498 D01, the SAR exclusion threshold for distances <50mm is defined by the following equation:

$$\frac{(\text{max. power of channel, including tune-up tolerance, mW})}{(\text{min. test separation distance, mm})} * \sqrt{\text{Frequency (GHz)}} \leq 3.0$$

Based on the above equation, Bluetooth SAR was required;

$$\text{Head Evaluation} = [10^{(11/10)}/5] * (2.480^{1/2}) = 3.966 > 3.0$$

$$\text{Body Evaluation} = [10^{(11/10)}/10] * (2.480^{1/2}) = 1.983 < 3.0$$

For conditions where the estimated SAR is overly conservative for certain conditions, the test lab may choose to perform standalone SAR measurements and use the measured SAR to determine simultaneous transmission SAR test exclusion.

Based on the above equation, WiFi SAR was required;

$$\text{Head Evaluation} = [10^{(23/10)}/5] * (2.462^{1/2}) = 98.2 > 3.0$$

$$\text{Body Evaluation} = [10^{(23/10)}/10] * (2.462^{1/2}) = 49.1 > 3.0$$

TA Technology (Shanghai) Co., Ltd.

Test Report

7.3. SAR Test Results

7.3.1. GSM 850 (GPRS)

Table 15: SAR Values [GSM 850 (GPRS)]

Test Position	Channel/Frequency (MHz)	Time slot	Duty Cycle	Maximum Allowed Power (dBm)	Conducted Power (dBm)	Drift ± 0.21dB	Limit SAR _{1g} 1.6 W/kg			
						Drift (dB)	Measured SAR _{1g} (W/kg)	Scaling Factor	Reported SAR _{1g} (W/kg)	Graph Results
Test Position of Head										
Left/Cheek	190/836.6	GSM	1:1	33	31.98	0.047	0.0053	1.26	0.007	Figure16
Left/Tilt	190/836.6	GSM	1:1	33	31.98	-0.087	0.0024	1.26	0.003	Figure17
Right/Cheek	190/836.6	GSM	1:1	33	31.98	-0.028	0.0021	1.26	0.003	Figure18
Right/Tilt	190/836.6	GSM	1:1	33	31.98	0.173	0.0018	1.26	0.002	Figure19
Test position of Body (Distance 10mm)										
Back Side	190/836.6	3 Txslots	1:277	29.6	28.67	0.032	0.0295	1.24	0.037	Figure20
Front Side	190/836.6	3 Txslots	1:27	29.6	28.67	0.010	0.0152	1.24	0.019	Figure21
Left Edge	190/836.6	3 Txslots	1:277	29.6	28.67	0.031	0.0067	1.24	0.008	Figure22
Right Edge	190/836.6	3 Txslots	1:277	29.6	28.67	0.038	0.0105	1.24	0.013	Figure23
Top Edge	190/836.6	3 Txslots	1:277	NA	NA	NA	NA	NA	NA	NA
Bottom Edge	190/836.6	3 Txslots	1:277	29.6	28.67	0.050	0.0088	1.24	0.011	Figure24

Note: 1. The value with blue color is the maximum SAR Value of each test band.

2. Per FCC KDB Publication 447498 D01, if the reported (scaled) SAR measured at the middle channel or highest output power channel for each test configuration is ≤ 0.8 W/kg then testing at the other channels is not required for such test configuration(s).

3. WWAN antenna is located at bottom edge; antenna-to-top edge distance is more than 2.5 cm (see ANNEX J). Based upon KDB941225 D06, when the antenna-to-edge distance is greater than 2.5cm, such position does not need to be tested.

4. When multiple slots are used, SAR should be tested to account for the maximum source-based time-averaged output power.

5. Per FCC KDB Publication 648474 D04, SAR was evaluated without a headset connected to the device. Since the reported SAR was ≤ 1.2 W/kg, no additional SAR evaluations using a headset cable were required.

TA Technology (Shanghai) Co., Ltd.

Test Report

7.3.2. GSM 1900 (GPRS)

Table 16: SAR Values [GSM 1900(GPRS)]

Test Position	Channel/Frequency (MHz)	Time slot	Duty Cycle	Maximum Allowed Power (dBm)	Conducted Power (dBm)	Drift ± 0.21dB	Limit SAR _{1g} 1.6 W/kg			
						Drift (dB)	Measured SAR _{1g} (W/kg)	Scaling Factor	Reported SAR _{1g} (W/kg)	Graph Results
Test Position of Head										
Left/Cheek	661/1880	GSM	1:1	30.5	29.64	-0.050	0.2820	1.22	0.344	Figure25
Left/Tilt	661/1880	GSM	1:1	30.5	29.64	0.025	0.0780	1.22	0.095	Figure26
Right/Cheek	661/1880	GSM	1:1	30.5	29.64	-0.150	0.2770	1.22	0.338	Figure27
Right/Tilt	661/1880	GSM	1:1	30.5	29.64	0.130	0.0730	1.22	0.089	Figure28
Test position of Body (Distance 10mm)										
Back Side	810/1909.8	2Txslots	1:4.15	29.2	28.25	0.001	0.8240 (max.cube)	1.24	1.025	Figure29
	661/1880	2Txslots	1:4.15	29.2	28.19	-0.050	0.8320	1.26	1.050	Figure30
	512/1850.2	2Txslots	1:4.15	29.2	28.01	-0.050	0.8680	1.32	1.142	Figure31
Front Side	512/1850.2	2Txslots	1:4.15	29.2	28.19	-0.030	0.5390	1.26	0.680	Figure32
Left Edge	512/1850.2	2Txslots	1:4.15	29.2	28.19	0.160	0.2800	1.26	0.353	Figure33
Right Edge	512/1850.2	2Txslots	1:4.15	29.2	28.19	0.060	0.1740	1.26	0.220	Figure34
Top Edge	512/1850.2	2Txslots	1:4.15	NA	NA	NA	NA	NA	NA	NA
Bottom Edge	512/1850.2	2Txslots	1:4.15	29.2	28.19	0.020	0.6220	1.26	0.785	Figure35
Worst Case Position of Body (1st Repeated SAR, Distance 10mm)										
Back Side	512/1850.2	2Txslots	1:4.15	29.2	28.01	-0.050	0.8080	1.32	1.063	Figure36

Note: 1. The value with blue color is the maximum SAR Value of each test band.

2. Per FCC KDB Publication 447498 D01, if the reported (scaled) SAR measured at the middle channel or highest output power channel for each test configuration is ≤ 0.8 W/kg then testing at the other channels is not required for such test configuration(s).
3. WWAN antenna is located at bottom edge; antenna-to-top edge distance is more than 2.5 cm (see ANNEX J). Based upon KDB941225 D06, when the antenna-to-edge distance is greater than 2.5cm, such position does not need to be tested.
4. When multiple slots are used, SAR should be tested to account for the maximum source-based time-averaged output power.
5. Per FCC KDB Publication 648474 D04, SAR was evaluated without a headset connected to the device. Since the reported SAR was ≤ 1.2 W/kg, no additional SAR evaluations using a headset cable were required.
6. The (max.cube) labeling indicates that during the grid scanning an additional peak was found which was within 2.0dB of the highest peak. The value of the highest cube is given in the table above.

TA Technology (Shanghai) Co., Ltd.
Test Report

Report No.: RXA1307-0093SAR01R3

Page 45 of 225

Table 17: SAR Measurement Variability Results [GSM 1900 (GPRS)]

Test Position	Channel	Measured SAR (1g)	1st Repeated SAR (1g)	Ratio	2nd Repeated SAR (1g)	3rd Repeated SAR (1g)
Back Side	512/1850.2	0.8680	0.8080	1.07	NA	NA

Note: 1) When the original highest measured SAR is ≥ 0.80 W/kg, the measurement was repeated once.
2) A second repeated measurement was performed only if the ratio of largest to smallest SAR for the original and first repeated measurements was > 1.20 or when the original or repeated measurement was ≥ 1.45 W/kg (~ 10% from the 1-g SAR limit).
3) A third repeated measurement was performed only if the original, first or second repeated measurement was ≥ 1.5 W/kg and the ratio of largest to smallest SAR for the original, first and second repeated measurements is > 1.20 .
4) Repeated measurements are not required when the original highest measured SAR is < 0.80 W/kg

TA Technology (Shanghai) Co., Ltd.

Test Report

7.3.3. UMTS Band II (WCDMA/HSDPA/HSUPA/DC-HSDPA)

Table 18: SAR Values [UMTS Band II (WCDMA/HSDPA/HSUPA/DC-HSDPA)]

Test Position	Channel/Frequency (MHz)	Data Rate	Duty Cycle	Maximum Allowed Power (dBm)	Conducted Power (dBm)	Drift	Limit SAR _{1g} 1.6 W/kg			
						± 0.21dB	Measured SAR _{1g} (W/kg)	Scaling Factor	Reported SAR _{1g} (W/kg)	Graph Results
Test Position of Head										
Left/Cheek	9400/1880	RMC12.2k	1:1	23.5	22.32	0.130	0.5400	1.31	0.709	Figure37
Left/Tilt	9400/1880	RMC12.2k	1:1	23.5	22.32	0.180	0.1470	1.31	0.193	Figure38
Right/Cheek	9400/1880	RMC12.2k	1:1	23.5	22.32	0.090	0.5430	1.31	0.713	Figure39
Right/Tilt	9400/1880	RMC12.2k	1:1	23.5	22.32	0.040	0.1350	1.31	0.177	Figure40
Test Position of Body with Hotspot Closed 15mm										
Back Side	9538/1907.6	RMC12.2k	1:1	23.5	22.05	-0.090	0.5760	1.40	0.804	Figure41
	9400/1880	RMC12.2k	1:1	23.5	22.32	-0.110	0.6370	1.31	0.836	Figure42
	9262/1852.4	RMC12.2k	1:1	23.5	22.28	-0.050	0.6580	1.32	0.871	Figure43
Front Side	9400/1880	RMC12.2k	1:1	23.5	22.32	-0.050	0.4570	1.31	0.600	Figure44
Test Position of Body with Hotspot Open 10mm										
Back Side	9538/1907.6	RMC12.2k	1:1	21.6	20.54	-0.020	0.7060	1.28	0.901	Figure45
	9400/1880	RMC12.2k	1:1	21.6	20.72	-0.049	0.7600	1.22	0.931	Figure46
	9262/1852.4	RMC12.2k	1:1	21.6	20.67	-0.120	0.7720	1.24	0.956	Figure47
Front Side	9400/1880	RMC12.2k	1:1	21.6	20.72	-0.170	0.4870	1.22	0.596	Figure48
Left Edge	9400/1880	RMC12.2k	1:1	21.6	20.72	-0.030	0.3110	1.22	0.381	Figure49
Right Edge	9400/1880	RMC12.2k	1:1	21.6	20.72	-0.080	0.1420	1.22	0.174	Figure50
Top Edge	9400/1880	RMC12.2k	1:1	NA	NA	NA	NA	NA	NA	NA
Bottom Edge	9400/1880	RMC12.2k	1:1	21.6	20.72	0.080	0.4870	1.22	0.596	Figure51

Note: 1. The value with blue color is the maximum SAR Value of each test band.

2. Per FCC KDB Publication 447498 D01, if the reported (scaled) SAR measured at the middle channel or highest output power channel for each test configuration is ≤ 0.8 W/kg then testing at the other channels is not required for such test configuration(s).
3. WCDMA mode was tested under RMC 12.2kbps without HSPA (HSDPA/HSUPA) inactive per KDB Publication 941225 D01. HSPA (HSDPA/HSUPA) SAR for body was not required since the average output power of the HSPA (HSDPA/HSUPA) subtests was not more than 0.25 dB higher than the RMC level and the maximum SAR for 12.2kbps RMC was less than 75% SAR limit.
4. When the maximum average output power of each RF channel with (uplink) HSPA+ or DC-HSDPA active is ≤ ¼ dB higher than that measured without HSPA+ or DC-HSDPA using 12.2 kbps RMC, or the maximum SAR for 12.2 kbps RMC without HSPA+ or DC-HSDPA is ≤ 75% of the SAR limit, SAR evaluation for HSPA+ or DC-HSDPA is not required.
5. WWAN antenna is located at bottom edge; antenna-to-top edge distance is more than 2.5 cm (see ANNEX J). Based upon KDB941225 D06, when the antenna-to-edge distance is greater than 2.5cm, such position does not need to be tested.
6. Per FCC KDB Publication 648474 D04, SAR was evaluated without a headset connected to the device. Since the reported SAR was ≤ 1.2 W/kg, no additional SAR evaluations using a headset cable were required.

TA Technology (Shanghai) Co., Ltd.

Test Report

Report No.: RXA1307-0093SAR01R3

Page 47 of 225

7.3.4. UMTS Band IV (WCDMA/HSDPA/HSUPA/DC-HSDPA)

Table 19: SAR Values [UMTS Band IV (WCDMA/HSDPA/HSUPA/DC-HSDPA)]

Test Position	Channel/ Frequency (MHz)	Data Rate	Duty Cycle	Maximum Allowed Power (dBm)	Conducted Power (dBm)	Drift ± 0.21dB	Limit SAR _{1g} 1.6 W/kg			
						Drift (dB)	Measured SAR _{1g} (W/kg)	Scaling Factor	Reported SAR _{1g} (W/kg)	Graph Results
Test Position of Head										
Left/Cheek	1413/1732.6	RMC 12.2k	1:1	23.5	22.65	0.031	0.6440	1.22	0.783	Figure52
Left/Tilt	1413/1732.6	RMC 12.2k	1:1	23.5	22.65	0.170	0.2250	1.22	0.274	Figure53
Right/Cheek	1413/1732.6	RMC 12.2k	1:1	23.5	22.65	0.030	0.6060	1.22	0.737	Figure54
Right/Tilt	1413/1732.6	RMC 12.2k	1:1	23.5	22.65	0.130	0.2580	1.22	0.314	Figure55
Test Position of Body with Hotspot Closed 15mm										
Back Side	1513/1752.6	RMC 12.2k	1:1	23.5	22.32	-0.070	0.6340	1.31	0.832	Figure56
	1413/1732.6	RMC 12.2k	1:1	23.5	22.65	0.041	0.7480	1.22	0.910	Figure57
	1312/1712.4	RMC 12.2k	1:1	23.5	22.43	0.025	0.5950	1.28	0.761	Figure58
Front Side	1413/1732.6	RMC 12.2k	1:1	23.5	22.65	-0.040	0.4460	1.22	0.542	Figure59
Test Position of Body with Hotspot Open 10mm										
Back Side	1513/1752.6	RMC 12.2k	1:1	22	20.82	-0.070	0.8050	1.31	1.056	Figure60
	1413/1732.6	RMC 12.2k	1:1	22	21.1	-0.030	0.9190	1.23	1.131	Figure61
	1312/1712.4	RMC 12.2k	1:1	22	20.97	0.048	0.6980	1.27	0.885	Figure62
Front Side	1413/1732.6	RMC 12.2k	1:1	22	21.1	0.001	0.5490	1.23	0.675	Figure63
Left Edge	1413/1732.6	RMC 12.2k	1:1	22	21.1	0.060	0.3160	1.23	0.389	Figure64
Right Edge	1413/1732.6	RMC 12.2k	1:1	22	21.1	0.040	0.1770	1.23	0.218	Figure65
Top Edge	1413/1732.6	RMC 12.2k	1:1	NA	NA	NA	NA	NA	NA	NA
Bottom Edge	1513/1752.6	RMC 12.2k	1:1	22	20.82	0.070	0.5560	1.31	0.730	Figure66
	1413/1732.6	RMC 12.2k	1:1	22	21.1	0.040	0.7170	1.23	0.882	Figure67
	1312/1712.4	RMC 12.2k	1:1	22	20.97	0.100	0.5790	1.27	0.734	Figure68
Worst Case Position of Body (1st Repeated SAR, Distance 10mm)										
Back Side	1413/1732.6	RMC 12.2k	1:1	22	21.1	-0.08	0.9380	1.23	1.154	Figure69

Note: 1. The value with blue color is the maximum SAR Value of each test band.

2. Per FCC KDB Publication 447498 D01, if the reported (scaled) SAR measured at the middle channel or highest output power channel for each test configuration is ≤ 0.8 W/kg then testing at the other channels is not required for such test configuration(s).

3. WCDMA mode was tested under RMC 12.2kbps without HSPA (HSDPA/HSUPA) inactive per KDB Publication 941225 D01. HSPA (HSDPA/HSUPA) SAR for body was not required since the average output power of the HSPA (HSDPA/HSUPA) subtests

TA Technology (Shanghai) Co., Ltd.

Test Report

was not more than 0.25 dB higher than the RMC level and the maximum SAR for 12.2kbps RMC was less than 75% SAR limit.

4. When the maximum average output power of each RF channel with (uplink) HSPA+ or DC-HSDPA active is $\leq \frac{1}{4}$ dB higher than that measured without HSPA+ or DC-HSDPA using 12.2 kbps RMC, or the maximum SAR for 12.2 kbps RMC without HSPA+ or DC-HSDPA is $\leq 75\%$ of the SAR limit, SAR evaluation for HSPA+ or DC-HSDPA is not required.

5. WWAN antenna is located at bottom edge, near to right edge; antenna-to-top/left edge distance is more than 2.5 cm (see ANNEX L). Based upon KDB941225 D06, when the antenna-to-edge distance is greater than 2.5cm, such position does not need to be tested.

6. Per FCC KDB Publication 648474 D04, SAR was evaluated without a headset connected to the device. Since the reported SAR was ≤ 1.2 W/kg, no additional SAR evaluations using a headset cable were required.

Table 20: SAR Measurement Variability Results
[UMTS Band IV (WCDMA/HSDPA/HSUPA/DC-HSDPA)]

Test Position	Channel/ Frequency (MHz)	Measured SAR (1g)	1 st Repeated SAR (1g)	Ratio	2 nd Repeated SAR (1g)	3 rd Repeated SAR (1g)
Back Side	1413/1732.6	0.9190	0.9380	1.02	NA	NA

Note: 1) When the original highest measured SAR is ≥ 0.80 W/kg, the measurement was repeated once.

2) A second repeated measurement was performed only if the ratio of largest to smallest SAR for the original and first repeated measurements was > 1.20 or when the original or repeated measurement was ≥ 1.45 W/kg (~ 10% from the 1-g SAR limit).

3) A third repeated measurement was performed only if the original, first or second repeated measurement was ≥ 1.5 W/kg and the ratio of largest to smallest SAR for the original, first and second repeated measurements is > 1.20 .

4) Repeated measurements are not required when the original highest measured SAR is < 0.80 W/kg

TA Technology (Shanghai) Co., Ltd.

Test Report

7.3.5. UMTS Band V (WCDMA/HSDPA/HSUPA/DC-HSDPA)

Table 21: SAR Values [UMTS Band V (WCDMA/HSDPA/HSUPA/DC-HSDPA)]

Test Position	Channel/Frequency (MHz)	Data Rate	Duty Cycle	Maximum Allowed Power (dBm)	Conducted Power (dBm)	Drift ± 0.21dB	Limit SAR _{1g} 1.6 W/kg			
						Drift (dB)	Measured SAR _{1g} (W/kg)	Scaling Factor	Reported SAR _{1g} (W/kg)	Graph Results
Test Position of Head										
Left/Cheek	4183/836.6	RMC12.2k	1:1	23.2	22.12	0.028	0.0060	1.28	0.008	Figure70
Left/Tilt	4183/836.6	RMC 12.2k	1:1	23.2	22.12	0.085	0.0025	1.28	0.003	Figure71
Right/Cheek	4183/836.6	RMC 12.2k	1:1	23.2	22.12	0.088	0.0054	1.28	0.007	Figure72
Right/Tilt	4183/836.6	RMC 12.2k	1:1	23.2	22.12	0.038	0.0023	1.28	0.003	Figure73
Test position of Body (Distance 10mm)										
Back Side	4183/836.6	RMC 12.2k	1:1	23.2	22.12	0.100	0.0314	1.28	0.040	Figure74
Front Side	4183/836.6	RMC 12.2k	1:1	23.2	22.12	0.083	0.0163	1.28	0.021	Figure75
Left Edge	4183/836.6	RMC 12.2k	1:1	23.2	22.12	0.095	0.0050	1.28	0.006	Figure76
Right Edge	4183/836.6	RMC 12.2k	1:1	23.2	22.12	0.058	0.0050	1.28	0.006	Figure77
Top Edge	4183/836.6	RMC 12.2k	1:1	NA	NA	NA	NA	NA	NA	NA
Bottom Edge	4183/836.6	RMC 12.2k	1:1	23.2	22.12	0.075	0.0100	1.28	0.013	Figure78

Note: 1. The value with blue color is the maximum SAR Value of each test band.

2. Per FCC KDB Publication 447498 D01, if the reported (scaled) SAR measured at the middle channel or highest output power channel for each test configuration is ≤ 0.8 W/kg then testing at the other channels is not required for such test configuration(s).
3. WCDMA mode was tested under RMC 12.2kbps without HSPA (HSDPA/HSUPA) inactive per KDB Publication 941225 D01. HSPA (HSDPA/HSUPA) SAR for body was not required since the average output power of the HSPA (HSDPA/HSUPA) subtests was not more than 0.25 dB higher than the RMC level and the maximum SAR for 12.2kbps RMC was less than 75% SAR limit.
4. When the maximum average output power of each RF channel with (uplink) HSPA+ or DC-HSDPA active is ≤ ¼ dB higher than that measured without HSPA+ or DC-HSDPA using 12.2 kbps RMC, or the maximum SAR for 12.2 kbps RMC without HSPA+ or DC-HSDPA is ≤ 75% of the SAR limit, SAR evaluation for HSPA+ or DC-HSDPA is not required.
5. WWAN antenna is located at bottom edge; antenna-to-top edge distance is more than 2.5 cm (see ANNEX J). Based upon KDB941225 D06, when the antenna-to-edge distance is greater than 2.5cm, such position does not need to be tested.
6. Per FCC KDB Publication 648474 D04v01, SAR was evaluated without a headset connected to the device. Since the reported SAR was ≤ 1.2 W/kg, no additional SAR evaluations using a headset cable were required.

TA Technology (Shanghai) Co., Ltd.

Test Report

7.3.6. WIFI (802.11b)

Table 22: SAR Values (802.11b)

Test Position	Channel/Frequency (MHz)	Service	Duty Cycle	Maximum Allowed Power (dBm)	Conducted Power (dBm)	Drift ± 0.21 dB	Limit of SAR 1.6 W/kg			
						Drift (dB)	Measured SAR _{1g} (W/kg)	Scaling Factor	Reported SAR _{1g} (W/kg)	Graph Results
Test Position of Head										
Left/Cheek	6/2437	DSSS	1:1	23	22.51	0.010	0.6620	1.12	0.741	Figure79
Left/Tilt	6/2437	DSSS	1:1	23	22.51	-0.160	0.4060	1.12	0.454	Figure80
Right/Cheek	6/2437	DSSS	1:1	23	22.51	-0.024	0.3350	1.12	0.375	Figure81
Right/Tilt	6/2437	DSSS	1:1	23	22.51	-0.080	0.3320	1.12	0.372	Figure82
Test position of Body (Distance 10mm)										
Back Side	6/2437	DSSS	1:1	23	22.51	0.020	0.2900	1.12	0.325	Figure83
Front Side	6/2437	DSSS	1:1	23	22.51	0.050	0.2010	1.12	0.225	Figure84
Left Edge	6/2437	DSSS	1:1	NA	NA	NA	NA	NA	NA	NA
Right Edge	6/2437	DSSS	1:1	23	22.51	0.140	0.3210	1.12	0.359	Figure85
Top Edge	6/2437	DSSS	1:1	23	22.51	0.070	0.2190	1.12	0.245	Figure86
Bottom Edge	6/2437	DSSS	1:1	NA	NA	NA	NA	NA	NA	NA
Test position of Body (Distance 15mm)										
Back Side	6/2437	DSSS	1:1	23	22.51	-0.140	0.2800	1.12	0.313	Figure87

Note: 1. The value with blue color is the maximum SAR Value of each test band.

2. Per FCC KDB Publication 447498 D01, if the reported (scaled) SAR measured at the middle channel or highest output power channel for each test configuration is ≤ 0.8 W/kg then testing at the other channels is not required for such test configuration(s).

3. WLAN antenna is located at Right/Top edge; antenna-to-Left/Bottom edge distance is more than 2.5 cm (see ANNEX J). Based upon KDB941225 D06, when the antenna-to-edge distance is greater than 2.5cm, such position does not need to be tested.

4. KDB 248227-SAR is not required for 802.11g/n channels when the maximum average output power is less than 1/4 dB higher than measured on the corresponding 802.11b channels.

5. Per FCC KDB Publication 648474 D04, SAR was evaluated without a headset connected to the device. Since the reported SAR was ≤ 1.2 W/kg, no additional SAR evaluations using a headset cable were required.

TA Technology (Shanghai) Co., Ltd.

Test Report

7.3.7. BT

Table 23: SAR Values

Test Position	Channel/Frequency (MHz)	Service	Duty Cycle	Maximum Allowed Power (dBm)	Conducted Power (dBm)	Drift ± 0.21dB	Limit of SAR 1.6 W/kg			
						Drift (dB)	Measured SAR _{1g} (W/kg)	Scaling Factor	Reported SAR _{1g} (W/kg)	Graph Results
Test Position of Head										
Left/Cheek	0/2402	DSSS	1:1	11	10.72	0.020	0.0798	1.07	0.085	Figure88
Left/Tilt	0/2402	DSSS	1:1	11	10.72	0.050	0.0688	1.07	0.073	Figure89
Right/Cheek	0/2402	DSSS	1:1	11	10.72	-0.060	0.1180	1.07	0.126	Figure90
Right/Tilt	0/2402	DSSS	1:1	11	10.72	0.070	0.1050	1.07	0.112	Figure91
Test position of Body (Distance 10mm)										
Back Side	0/2402	DSSS	1:1	11	10.72	-0.140	0.0357	1.07	0.038	Figure92
Front Side	0/2402	DSSS	1:1	11	10.72	0.020	0.0265	1.07	0.028	Figure93
Left Edge	0/2402	DSSS	1:1	NA	NA	NA	NA	NA	NA	NA
Right Edge	0/2402	DSSS	1:1	11	10.72	0.040	0.0241	1.07	0.026	Figure94
Top Edge	0/2402	DSSS	1:1	11	10.72	-0.020	0.0234	1.07	0.025	Figure95
Bottom Edge	0/2402	DSSS	1:1	NA	NA	NA	NA	NA	NA	NA
Test position of Body (Distance 15mm)										
Back Side	0/2402	DSSS	1:1	11	10.72	-0.090	0.0271	1.07	0.029	Figure96

Note: 1. The value with blue color is the maximum SAR Value of each test band.
2. Per FCC KDB Publication 447498 D01, if the reported (scaled) SAR measured at the middle channel or highest output power channel for each test configuration is ≤ 0.8 W/kg then testing at the other channels is not required for such test configuration(s).
3. WLAN antenna is located at Right/Top edge; antenna-to-Left/Bottom edge distance is more than 2.5 cm (see ANNEX J). Based upon KDB941225 D06, when the antenna-to-edge distance is greater than 2.5cm, such position does not need to be tested.
4. Per FCC KDB Publication 648474 D04, SAR was evaluated without a headset connected to the device. Since the reported SAR was ≤ 1.2 W/kg, no additional SAR evaluations using a headset cable were required.

TA Technology (Shanghai) Co., Ltd.
Test Report

Report No.: RXA1307-0093SAR01R3

Page 52 of 225

7.4. Simultaneous Transmission Conditions

Air-Interface	Band (MHz)	Type	Simultaneous Transmissions	Voice Over Digital Transport (Data)
GSM	850	VO	Yes WIFI or BT	NA
	1900	VO		
	GPRS/EGPRS	DT	Yes WIFI or BT	NA
WCDMA	UMTS850/1700/ 1900	DT	Yes WIFI or BT	NA
WIFI	2450	DT	Yes GSM,GPRS,EGPRS,WCDMA	Yes
Bluetooth (BT)	2400	DT	Yes GSM,GPRS,EGPRS, WCDMA	NA
Note: VO Voice Service only DT Digital Transport				

The location of the antennas inside EUT is shown in ANNEX J:

TA Technology (Shanghai) Co., Ltd.
Test Report

Report No.: RXA1307-0093SAR01R3

Page 53 of 225

When standalone SAR is not required to be measured per FCC KDB 447498 D01, the following equation must be used to estimate the standalone 1g SAR for simultaneous transmission assessment involving that transmitter.

$$\text{Estimated SAR} = \frac{(\text{max. power of channel, including tune-up tolerance, mW})}{(\text{min. test separation distance, mm})} * \frac{\sqrt{f \text{ (GHz)}}}{7.5}$$

Per FCC KDB 447498 D01, simultaneous transmission SAR test exclusion may be applied when the sum of the 1-g SAR for all the simultaneous transmitting antennas in a specific a physical test configuration is ≤ 1.6 W/kg. When the sum is greater than the SAR limit, SAR test exclusion is determined by the SAR to peak location separation ratio.

$$\text{Ratio} = \frac{(\text{SAR}_1 + \text{SAR}_2)^{1.5}}{(\text{peak location separation, mm})} < 0.04$$

TA Technology (Shanghai) Co., Ltd.
Test Report

Report No.: RXA1307-0093SAR01R3

Page 54 of 225

GSM/UMTS & WIFI Mode (Hotspot Closed)

Reported SAR _{1g} (W/kg)	GSM 850	GSM 1900	UMTS Band V	WIFI	MAX. Σ SAR _{1g}
Test Position					
Left hand, Touch cheek	0.007	0.344	0.008	0.741	1.085
Left hand, Tilt 15 Degree	0.003	0.095	0.003	0.454	0.549
Right hand, Touch cheek	0.003	0.338	0.007	0.375	0.713
Right hand, Tilt 15 Degree	0.002	0.089	0.003	0.372	0.461
Body, Back Side(10mm)	0.037	1.142	0.040	0.325	1.467
Body, Front Side(10mm)	0.019	0.680	0.021	0.225	0.905
Note: 1. The value with blue color is the maximum ΣSAR _{1g} Value. 2. MAX. ΣSAR _{1g} = Reported SAR _{Max.WIFI} + Reported SAR _{Max.GSM/UMTS}					

Reported SAR _{1g} (W/kg)	UMTS Band II	UMTS Band IV	WIFI	MAX. Σ SAR _{1g}
Test Position				
Left hand, Touch cheek	0.709	0.783	0.741	1.524
Left hand, Tilt 15 Degree	0.193	0.274	0.454	0.728
Right hand, Touch cheek	0.713	0.737	0.375	1.112
Right hand, Tilt 15 Degree	0.177	0.314	0.372	0.686
Body, Back Side(15mm)	0.871	0.910	0.313	1.223
Note: 1. The value with blue color is the maximum ΣSAR _{1g} Value. 2. MAX. ΣSAR _{1g} = Reported SAR _{Max.WIFI} + Reported SAR _{Max.GSM/UMTS}				

MAX. ΣSAR_{1g} = 1.524 W/kg < 1.6 W/kg, So the Simultaneous SAR are not required for WIFI and GSM/UMTS antenna.

TA Technology (Shanghai) Co., Ltd.

Test Report

Report No.: RXA1307-0093SAR01R3

Page 55 of 225

GSM/UMTS & BT Mode (Hotspot Closed)

Reported SAR _{1g} (W/kg) Test Position	GSM 850	GSM 1900	UMTS Band V	BT	MAX. Σ SAR _{1g}
Left hand, Touch cheek	0.007	0.310	0.008	0.085	0.395
Left hand, Tilt 15 Degree	0.003	0.086	0.003	0.073	0.159
Right hand, Touch cheek	0.003	0.304	0.007	0.126	0.430
Right hand, Tilt 15 Degree	0.002	0.080	0.003	0.112	0.192
Body, Back Side(10mm)	0.037	1.142	0.040	0.038	1.180
Body, Front Side(10mm)	0.019	0.680	0.021	0.028	0.708

Note: 1. The value with blue color is the maximum ΣSAR_{1g} Value.
 2. MAX. ΣSAR_{1g} = Reported SAR_{Max.BT} + Reported SAR_{Max.GSM/UMTS}

Reported SAR _{1g} (W/kg) Test Position	UMTS Band II	UMTS Band IV	BT	MAX. Σ SAR _{1g}
Left hand, Touch cheek	0.709	0.783	0.085	0.868
Left hand, Tilt 15 Degree	0.193	0.274	0.073	0.347
Right hand, Touch cheek	0.713	0.737	0.126	0.863
Right hand, Tilt 15 Degree	0.177	0.314	0.112	0.426
Body, Back Side(15mm)	0.871	0.910	0.029	0.939

Note: 1. The value with blue color is the maximum ΣSAR_{1g} Value.
 2. MAX. ΣSAR_{1g} = Reported SAR_{Max.BT} + Reported SAR_{Max.GSM/UMTS}

MAX. ΣSAR_{1g} = 1.180 W/kg < 1.6 W/kg, So the Simultaneous SAR are not required for BT and GSM/UMTS antenna.

TA Technology (Shanghai) Co., Ltd.

Test Report

Report No.: RXA1307-0093SAR01R3

Page 56 of 225

GSM/UMTS & WIFI Mode (Hotspot Open)

Reported SAR _{1g} (W/kg)	GSM 850	GSM 1900	UMTS Band II	UMTS Band IV	UMTS Band V	WIFI	MAX. Σ SAR _{1g}
Test Position							
Body, Back Side	0.037	1.142	0.956	1.154	0.040	0.325	1.479
Body, Front Side	0.019	0.680	0.596	0.675	0.021	0.225	0.905
Body, Left Edge	0.008	0.353	0.381	0.389	0.006	NA	NA
Body, Right Edge	0.013	0.220	0.174	0.218	0.006	0.359	0.579
Body, Top Edge	NA	NA	NA	NA	NA	0.245	NA
Body, Bottom Edge	0.011	0.785	0.596	0.882	0.013	NA	NA

Note: 1. The value with blue color is the maximum ΣSAR_{1g} Value.
2. MAX. ΣSAR_{1g} = Reported SAR_{Max.WIFI} + Reported SAR_{Max.GSM/UMTS}

MAX. ΣSAR_{1g} = 1.479 W/kg < 1.6 W/kg, So the Simultaneous SAR are not required for WIFI and GSM/UMTS antenna.

GSM/UMTS & BT Mode(Hotspot Open)

Reported SAR _{1g} (W/kg)	GSM 850	GSM 1900	UMTS Band II	UMTS Band IV	UMTS Band V	BT	MAX. Σ SAR _{1g}
Test Position							
Body, Back Side	0.037	1.142	0.956	1.154	0.040	0.038	1.192
Body, Front Side	0.019	0.680	0.596	0.675	0.021	0.028	0.708
Body, Left Edge	0.008	0.353	0.381	0.389	0.006	NA	NA
Body, Right Edge	0.013	0.220	0.174	0.218	0.006	0.026	0.246
Body, Top Edge	NA	NA	NA	NA	NA	0.025	NA
Body, Bottom Edge	0.011	0.785	0.596	0.882	0.013	NA	NA

Note: 1. The value with blue color is the maximum ΣSAR_{1g} Value.
2. MAX. ΣSAR_{1g} = Reported SAR_{Max.BT} + Reported SAR_{Max.GSM/UMTS}

MAX. ΣSAR_{1g} = 1.192 W/kg < 1.6 W/kg, So the Simultaneous SAR are not required for BT and GSM/UMTS antenna.

WIFI module and BT module cannot transmit simultaneously.

TA Technology (Shanghai) Co., Ltd.
Test Report

Report No.: RXA1307-0093SAR01R3

Page 57 of 225

8. 700MHz to 3GHz Measurement Uncertainty

No.	source	Type	Uncertainty Value (%)	Probability Distribution	k	c _i	Standard uncertainty u _i (%)	Degree of freedom V _{eff} or V _i
1	System repetivity	A	0.5	N	1	1	0.5	9
Measurement system								
2	-probe calibration	B	6.0	N	1	1	6.0	∞
3	-axial isotropy of the probe	B	4.7	R	$\sqrt{3}$	$\sqrt{0.5}$	1.9	∞
4	- Hemispherical isotropy of the probe	B	9.4	R	$\sqrt{3}$	$\sqrt{0.5}$	3.9	∞
6	-boundary effect	B	1.9	R	$\sqrt{3}$	1	1.1	∞
7	-probe linearity	B	4.7	R	$\sqrt{3}$	1	2.7	∞
8	- System detection limits	B	1.0	R	$\sqrt{3}$	1	0.6	∞
9	-readout Electronics	B	1.0	N	1	1	1.0	∞
10	-response time	B	0	R	$\sqrt{3}$	1	0	∞
11	-integration time	B	4.32	R	$\sqrt{3}$	1	2.5	∞
12	-noise	B	0	R	$\sqrt{3}$	1	0	∞
13	-RF Ambient Conditions	B	3	R	$\sqrt{3}$	1	1.73	∞
14	-Probe Positioner Mechanical Tolerance	B	0.4	R	$\sqrt{3}$	1	0.2	∞
15	-Probe Positioning with respect to Phantom Shell	B	2.9	R	$\sqrt{3}$	1	1.7	∞
16	-Extrapolation, interpolation and Integration Algorithms for Max. SAR Evaluation	B	3.9	R	$\sqrt{3}$	1	2.3	∞
Test sample Related								
17	-Test Sample Positioning	A	2.9	N	1	1	2.9	71
18	-Device Holder Uncertainty	A	4.1	N	1	1	4.1	5
19	-Output Power Variation - SAR drift measurement	B	5.0	R	$\sqrt{3}$	1	2.9	∞
Physical parameter								
20	-phantom Uncertainty	B	4.0	R	$\sqrt{3}$	1	2.3	∞

TA Technology (Shanghai) Co., Ltd.
Test Report

Report No.: RXA1307-0093SAR01R3

Page 58 of 225

21	-liquid conductivity (deviation from target)	B	5.0	R	$\sqrt{3}$	0.64	1.8	∞	
22	-liquid conductivity (measurement uncertainty)	B	2.5	N	1	0.64	1.6	9	
23	-liquid permittivity (deviation from target)	B	5.0	R	$\sqrt{3}$	0.6	1.7	∞	
24	-liquid permittivity (measurement uncertainty)	B	2.5	N	1	0.6	1.5	9	
Combined standard uncertainty		$u_c = \sqrt{\sum_{i=1}^{24} c_i^2 u_i^2}$						11.50	
Expanded uncertainty (confidence interval of 95 %)		$u_e = 2u_c$		N	k=2			23.00	

TA Technology (Shanghai) Co., Ltd.
Test Report

Report No.: RXA1307-0093SAR01R3

Page 59 of 225

9. Main Test Instruments

Table 24: List of Main Instruments

No.	Name	Type	Serial Number	Calibration Date	Valid Period
01	Network analyzer	Agilent 8753E	US37390326	September 11, 2012	One year
02	Dielectric Probe Kit	Agilent 85070E	US44020115	No Calibration Requested	
03	Power meter	Agilent E4417A	GB41291714	March 10, 2013	One year
04	Power sensor	Agilent N8481H	MY50350004	September 24, 2012	One year
05	Power sensor	E9327A	US40441622	January 2, 2013	One year
06	Signal Generator	HP 8341B	2730A00804	September 10, 2012	One year
07	Dual directional coupler	778D-012	50519	March 25, 2013	One year
08	Dual directional coupler	777D	50146	March 25, 2013	One year
09	Amplifier	IXA-020	0401	No Calibration Requested	
10	BTS	E5515C	MY48360988	December 1, 2012	One year
11	E-field Probe	EX3DV4	3753	January 17, 2013	One year
12	DAE	DAE4	1317	January 25, 2013	One year
13	Validation Kit 835MHz	D835V2	4d020	August 26, 2011	Two years
14	Validation Kit 1750MHz	D1750V2	1023	June 20, 2012	Two years
15	Validation Kit 1900MHz	D1900V2	5d060	August 31, 2011	Two years
16	Validation Kit 2450MHz	D2450V2	786	August 29, 2011	Two years
17	Temperature Probe	JM222	AA1009129	March 14, 2013	One year
18	Hygrothermograph	WS-1	64591	September 27, 2012	One year
19	BT Base Station Simulator	CBT	100271	June 29, 2013	One year

*****END OF REPORT *****

ANNEX A: Test Layout



Picture 1: Specific Absorption Rate Test Layout



Picture 2: Liquid depth in the flat Phantom (835MHz, 15.4cm depth)

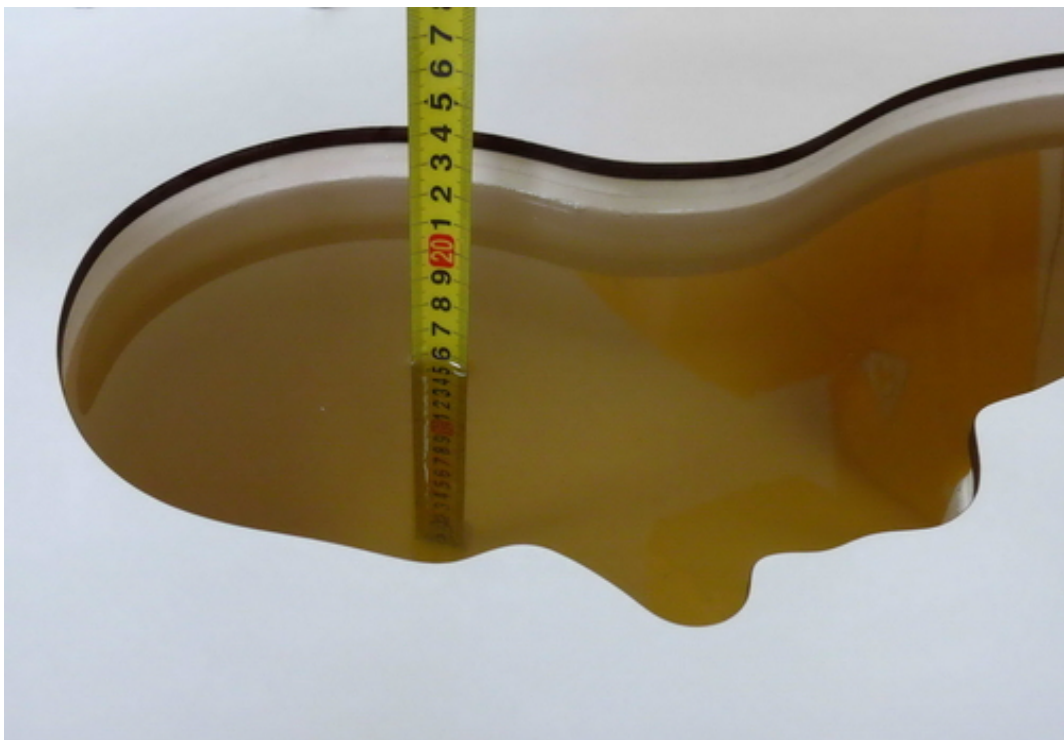

Picture 3: Liquid depth in the head Phantom (835MHz, 15.3cm depth)

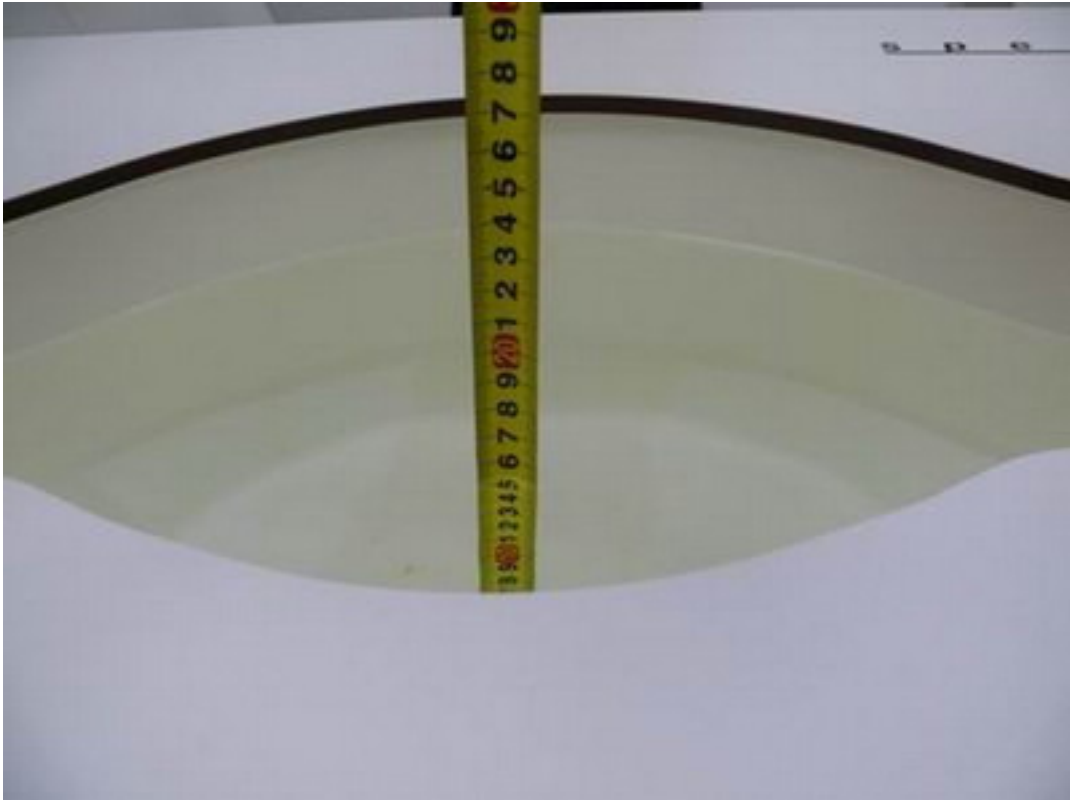

Picture 4: Liquid depth in the flat Phantom (1750 MHz, 15.4cm depth)



Picture 5: liquid depth in the head Phantom (1750 MHz, 15.2cm depth)

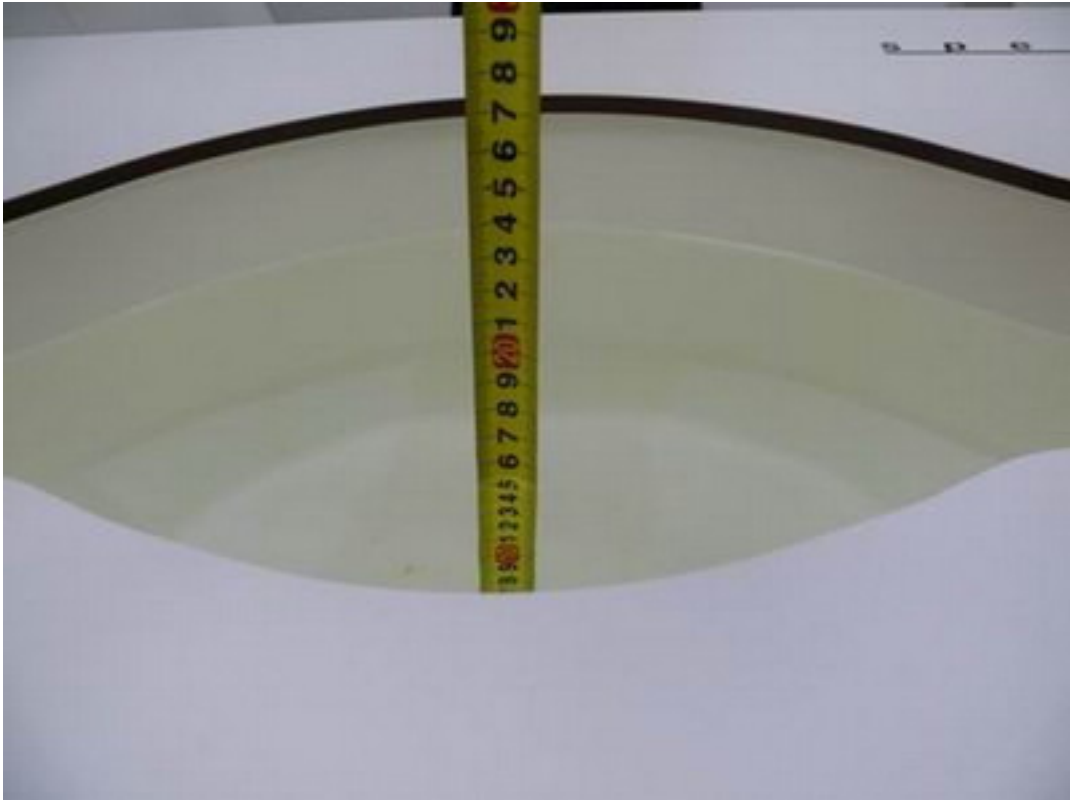

Picture 6: Liquid depth in the flat Phantom (1900 MHz, 15.2cm depth)



Picture 7: liquid depth in the head Phantom (1900 MHz, 15.3cm depth)

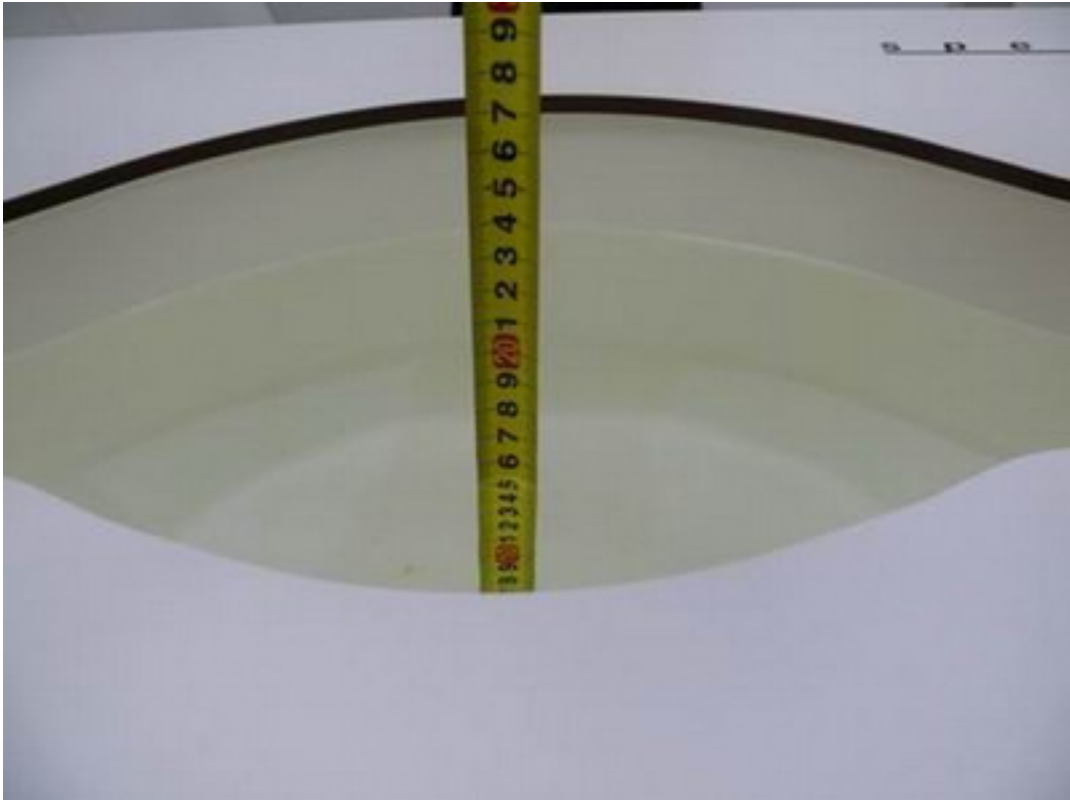

Picture 8: Liquid depth in the flat Phantom (2450 MHz, 15.3cm depth)



Picture 9: Liquid depth in the head Phantom (2450 MHz, 15.4cm depth)

ANNEX B: System Check Results

System Performance Check at 835 MHz Head TSL

DUT: Dipole 835 MHz; Type: D835V2; Serial: D835V2 - SN: 4d020

Date/Time: 7/20/2013 2:31:38 PM

Communication System: CW; Frequency: 835 MHz; Duty Cycle: 1:1

Medium parameters used: $f = 835$ MHz; $\sigma = 0.916$ mho/m; $\epsilon_r = 41.25$; $\rho = 1000$ kg/m³

Ambient Temperature: 22.3 °C Liquid Temperature: 21.5 °C

Phantom section: Flat Section

DASY5 Configuration:

Sensor-Surface: 4mm (Mechanical Surface Detection)

Probe: EX3DV4 - SN3753; ConvF(8.95, 8.95, 8.95); Calibrated: 1/17/2013

Electronics: DAE4 Sn1317; Calibrated: 1/25/2013

Phantom: SAM1; Type: SAM; Serial: TP-1534

Measurement SW: DASY52, Version 52.8 (2); SEMCAD X Version 14.6.6 (6824)

d=15mm, Pin=250mW/Area Scan (41x121x1): Measurement grid: dx=15mm, dy=15mm

Maximum value of SAR (interpolated) = 2.64 mW/g

d=15mm, Pin=250mW/Zoom Scan (7x7x7)/Cube 0: Measurement grid: dx=5mm, dy=5mm, dz=5mm

Reference Value = 54.4 V/m; Power Drift = -0.076 dB

Peak SAR (extrapolated) = 3.67 W/kg

SAR(1 g) = 2.44 mW/g; SAR(10 g) = 1.6 mW/g

Maximum value of SAR (measured) = 2.64 mW/g

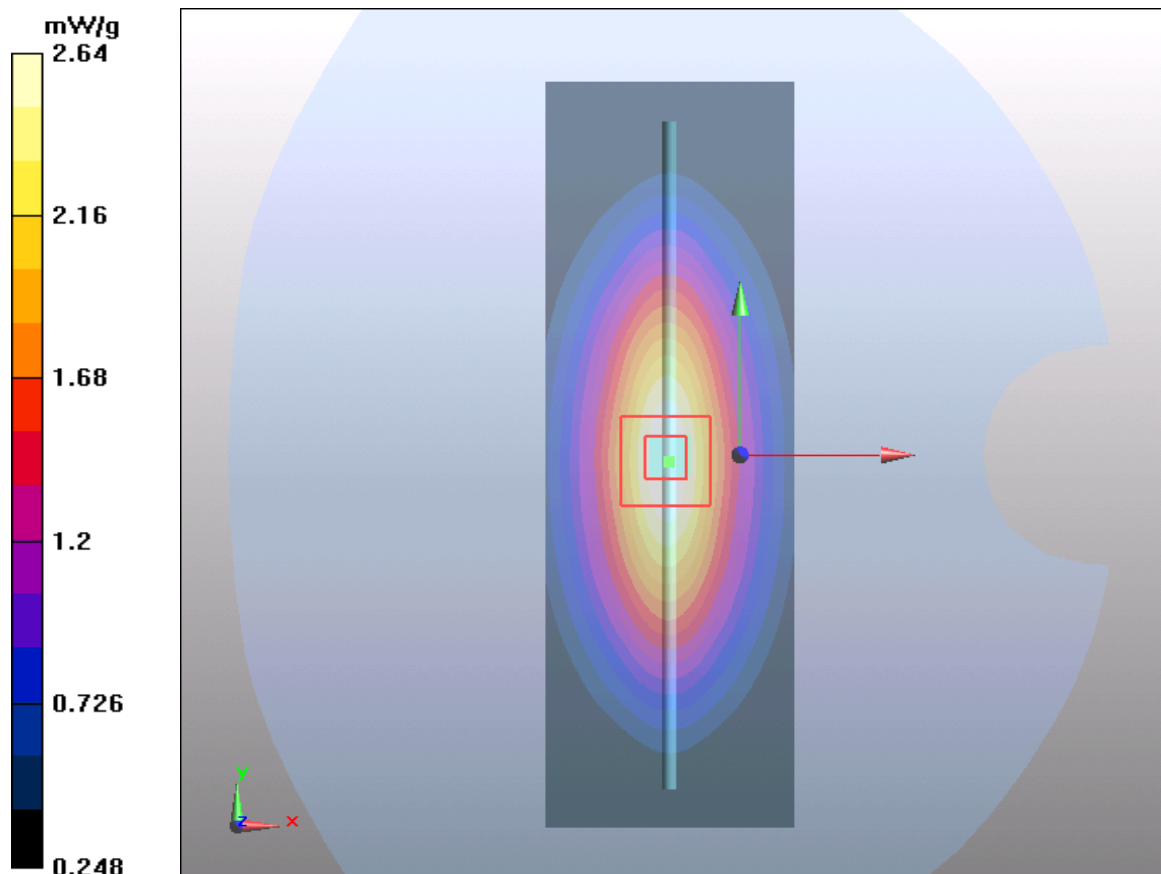

Figure 7 System Performance Check 835MHz 250mW

TA Technology (Shanghai) Co., Ltd. Test Report

Report No.: RXA1307-0093SAR01R3

Page 66 of 225

System Performance Check at 835 MHz Body TSL

DUT: Dipole 835 MHz; Type: D835V2; Serial: D835V2 - SN: 4d020

Date/Time: 7/20/2013 8:05:37 AM

Communication System: CW; Frequency: 835 MHz; Duty Cycle: 1:1

Medium parameters used: $f = 835$ MHz; $\sigma = 1.012$ mho/m; $\epsilon_r = 54.35$; $\rho = 1000$ kg/m³

Ambient Temperature: 22.3 °C Liquid Temperature: 21.5 °C

Phantom section: Flat Section

DASY5 Configuration:

Sensor-Surface: 4mm (Mechanical Surface Detection)

Probe: EX3DV4 - SN3753; ConvF(9.05, 9.05, 9.05); Calibrated: 1/17/2013

Electronics: DAE4 Sn1317; Calibrated: 1/25/2013

Phantom: SAM1; Type: SAM; Serial: TP-1534

Measurement SW: DASY52, Version 52.8 (2); SEMCAD X Version 14.6.6 (6824)

d=15mm, Pin=250mW/Area Scan (41x121x1): Measurement grid: dx=15mm, dy=15mm

Maximum value of SAR (interpolated) = 2.58 mW/g

d=15mm, Pin=250mW/Zoom Scan (7x7x7)/Cube 0: Measurement grid: dx=5mm, dy=5mm, dz=5mm

Reference Value = 51.9 V/m; Power Drift = -0.058 dB

Peak SAR (extrapolated) = 3.5 W/kg

SAR(1 g) = 2.41 mW/g; SAR(10 g) = 1.6 mW/g

Maximum value of SAR (measured) = 2.6 mW/g

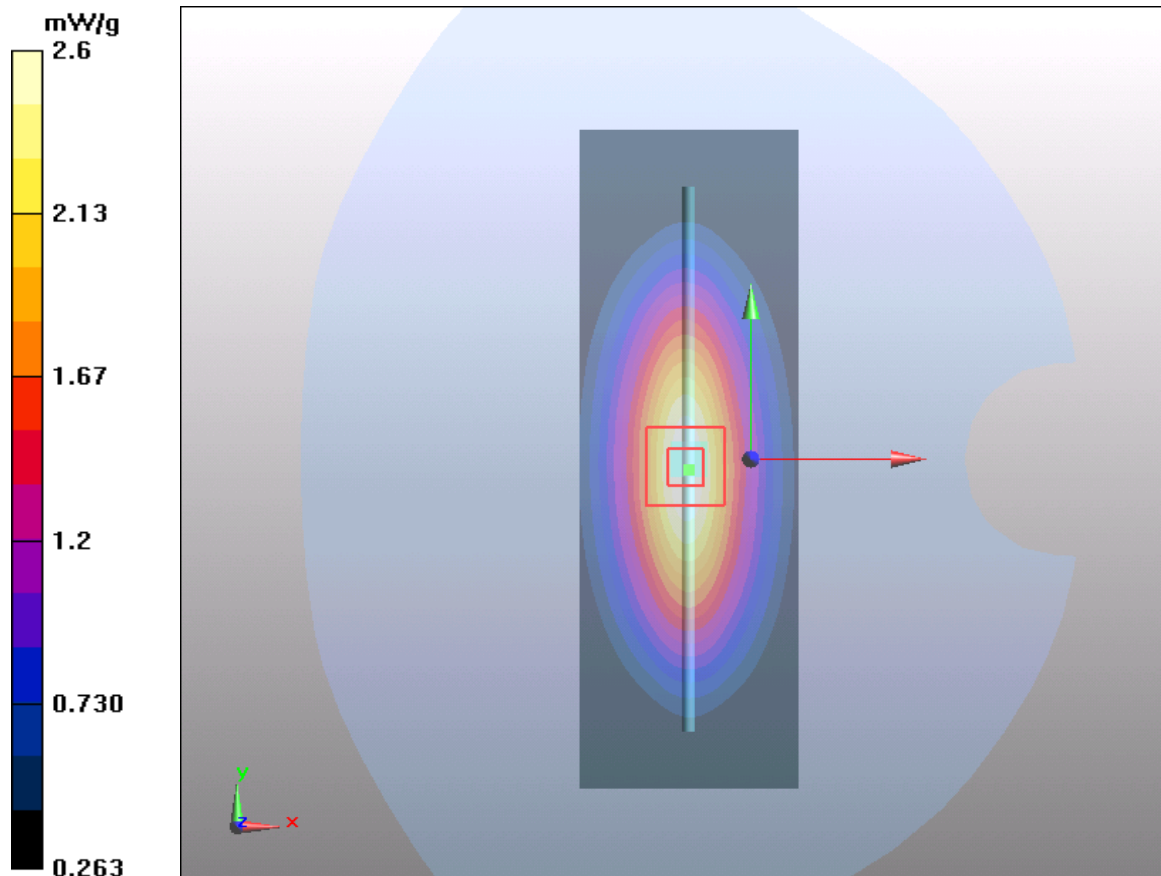

Figure 8 System Performance Check 835MHz 250mW

TA Technology (Shanghai) Co., Ltd. Test Report

Report No.: RXA1307-0093SAR01R3

Page 67 of 225

System Performance Check at 1750 MHz Head TSL

DUT: Dipole 1750 MHz; Type: D1750V2; Serial: D1750V2 - SN: 1023

Date/Time: 7/17/2013 11:03:44 AM

Communication System: CW; Frequency: 1750 MHz; Duty Cycle: 1:1

Medium parameters used: $f = 1750$ MHz; $\sigma = 1.398$ mho/m; $\epsilon_r = 39.17$; $\rho = 1000$ kg/m³

Ambient Temperature: 22.3 °C Liquid Temperature: 21.5 °C

Phantom section: Flat Section

DASY5 Configuration:

Sensor-Surface: 4mm (Mechanical Surface Detection)

Probe: EX3DV4 - SN3753; ConvF(7.86, 7.86, 7.86); Calibrated: 1/17/2013

Electronics: DAE4 Sn1317; Calibrated: 1/25/2013

Phantom: SAM1; Type: SAM; Serial: TP-1534

Measurement SW: DASY52, Version 52.8 (2); SEMCAD X Version 14.6.6 (6824)

d=10mm, Pin=250mW/Area Scan (51x81x1): Measurement grid: dx=15mm, dy=15mm

Maximum value of SAR (interpolated) = 9.78 mW/g

d=10mm, Pin=250mW/Zoom Scan (7x7x7)/Cube 0: Measurement grid: dx=5mm, dy=5mm, dz=5mm

Reference Value = 80 V/m; Power Drift = 0.075 dB

Peak SAR (extrapolated) = 15.5 W/kg

SAR(1 g) = 8.45 mW/g; SAR(10 g) = 4.5 mW/g

Maximum value of SAR (measured) = 9.46 mW/g

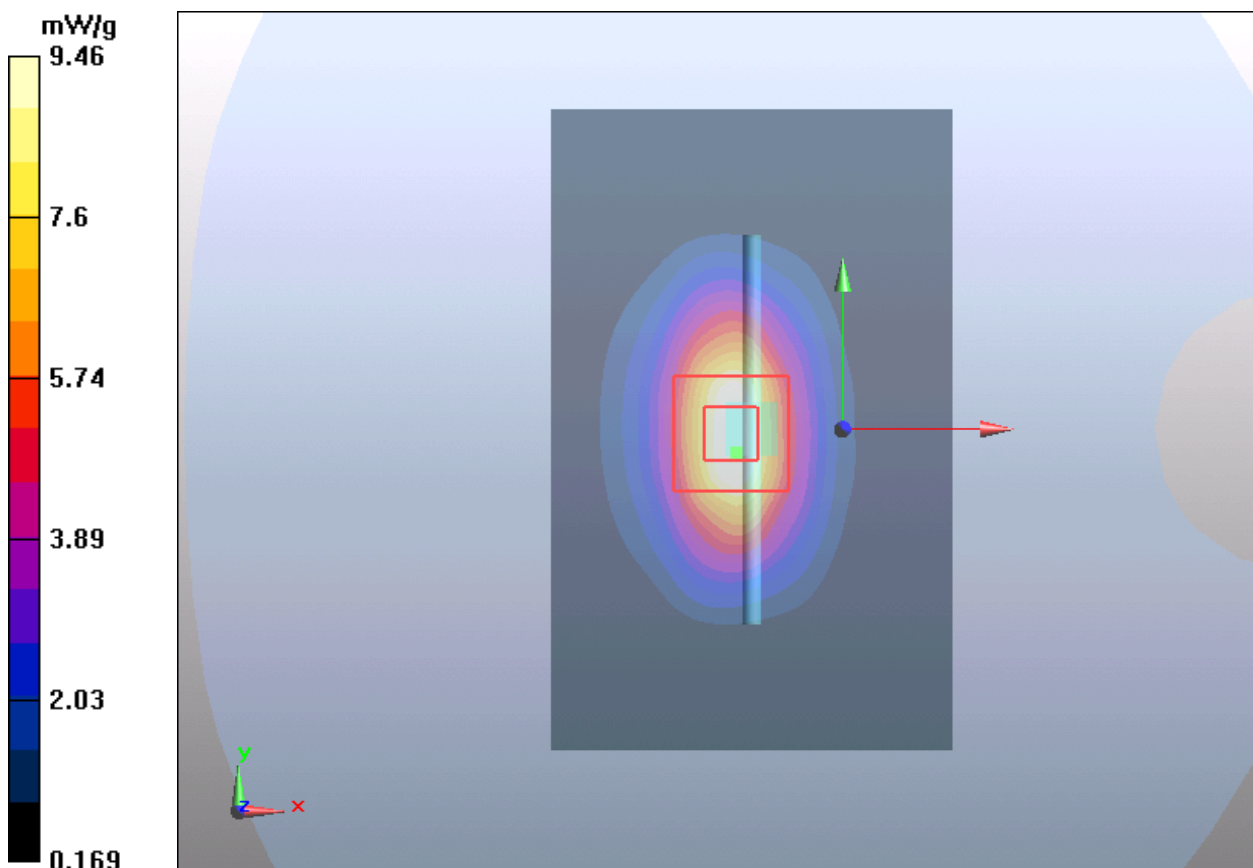

Figure 9 System Performance Check 1750MHz 250mW

TA Technology (Shanghai) Co., Ltd. Test Report

Report No.: RXA1307-0093SAR01R3

Page 68 of 225

System Performance Check at 1750 MHz Body TSL

DUT: Dipole 1750 MHz; Type: D1750V2; Serial: D1750V2 - SN: 1023

Date/Time: 7/19/2013 11:14:55 AM

Communication System: CW; Frequency: 1750 MHz; Duty Cycle: 1:1

Medium parameters used: $f = 1750$ MHz; $\sigma = 1.468$ mho/m; $\epsilon_r = 52.12$; $\rho = 1000$ kg/m³

Ambient Temperature: 22.3 °C Liquid Temperature: 21.7 °C

DASY5 Configuration:

Sensor-Surface: 4mm (Mechanical Surface Detection)

Probe: EX3DV4 - SN3753; ConvF(7.82, 7.82, 7.82); Calibrated: 1/17/2013

Electronics: DAE4 Sn1317; Calibrated: 1/25/2013

Phantom: SAM1; Type: SAM; Serial: TP-1534

Measurement SW: DASY52, Version 52.8 (2); SEMCAD X Version 14.6.6 (6824)

d=10mm, Pin=250mW/Area Scan (51x81x1): Measurement grid: dx=15mm, dy=15mm

Maximum value of SAR (interpolated) = 10.6 mW/g

d=10mm, Pin=250mW/Area Scan (7x7x7)/Cube 0: Measurement grid: dx=5mm, dy=5mm, dz=5mm

Reference Value = 77.7 V/m; Power Drift = 0.097 dB

Peak SAR (extrapolated) = 16.8 W/kg

SAR(1 g) = 9.24 mW/g; SAR(10 g) = 4.9 mW/g

Maximum value of SAR (measured) = 10.3 mW/g

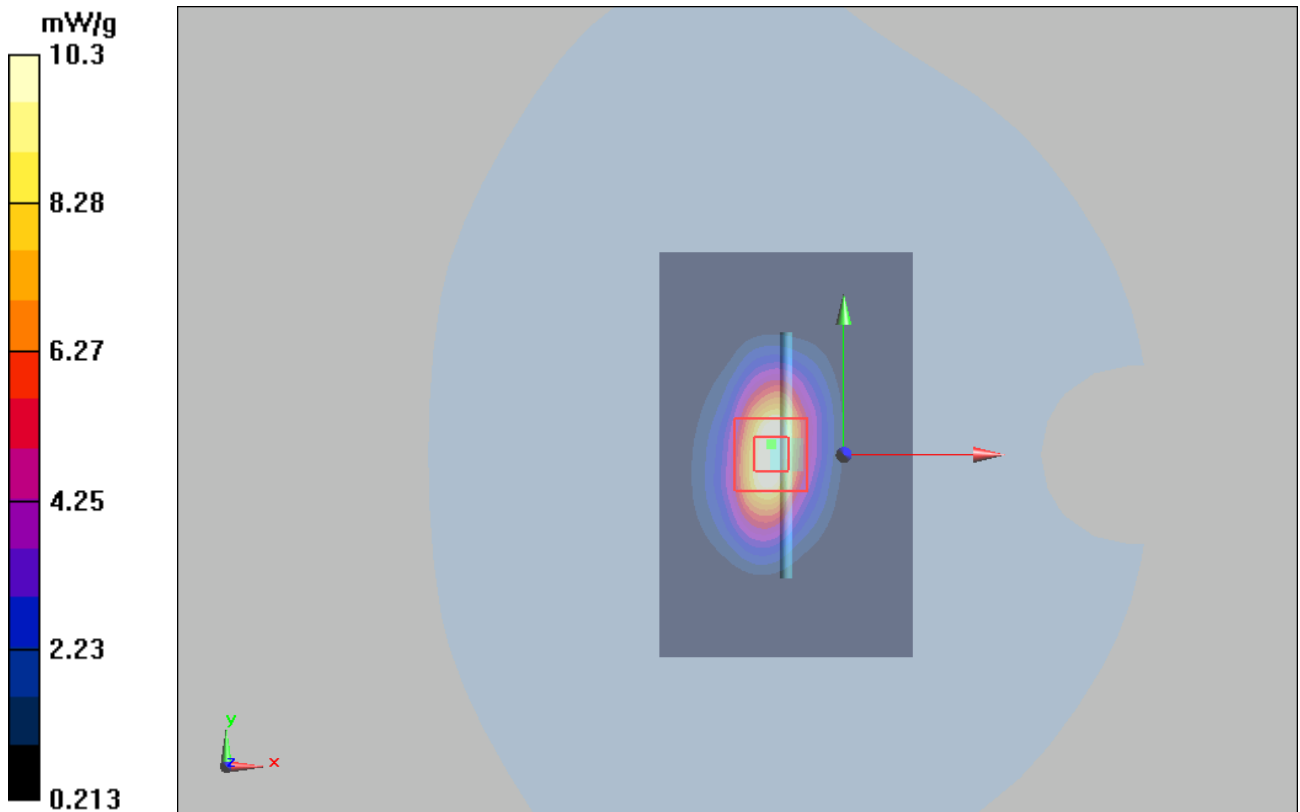

Figure 10 System Performance Check 1750MHz 250mW

TA Technology (Shanghai) Co., Ltd. Test Report

Report No.: RXA1307-0093SAR01R3

Page 69 of 225

System Performance Check at 1900 MHz Head TSL

DUT: Dipole 1900 MHz; Type: D1900V2; Serial: D1900V2 - SN: 5d060

Date/Time: 7/18/2013 4:04:55 AM

Communication System: CW; Frequency: 1900 MHz; Duty Cycle: 1:1

Medium parameters used: $f = 1900$ MHz; $\sigma = 1.451$ mho/m; $\epsilon_r = 38.33$; $\rho = 1000$ kg/m³

Ambient Temperature: 22.3 °C Liquid Temperature: 21.5 °C

Phantom section: Flat Section

DASY5 Configuration:

Sensor-Surface: 4mm (Mechanical Surface Detection)

Probe: EX3DV4 - SN3753; ConvF(7.63, 7.63, 7.63); Calibrated: 1/17/2013

Electronics: DAE4 Sn1317; Calibrated: 1/25/2013

Phantom: SAM1; Type: SAM; Serial: TP-1534

Measurement SW: DASY52, Version 52.8 (2); SEMCAD X Version 14.6.6 (6824)

d=10mm, Pin=250mW/Area Scan (41x71x1): Measurement grid: dx=15mm, dy=15mm

Maximum value of SAR (interpolated) = 11.3 mW/g

d=10mm, Pin=250mW/Zoom Scan (7x7x7)/Cube 0: Measurement grid: dx=5mm, dy=5mm,

dz=5mm

Reference Value = 85.5 V/m; Power Drift = 0.028 dB

Peak SAR (extrapolated) = 17.8 W/kg

SAR(1 g) = 9.48 mW/g; SAR(10 g) = 4.9 mW/g

Maximum value of SAR (measured) = 10.7 mW/g

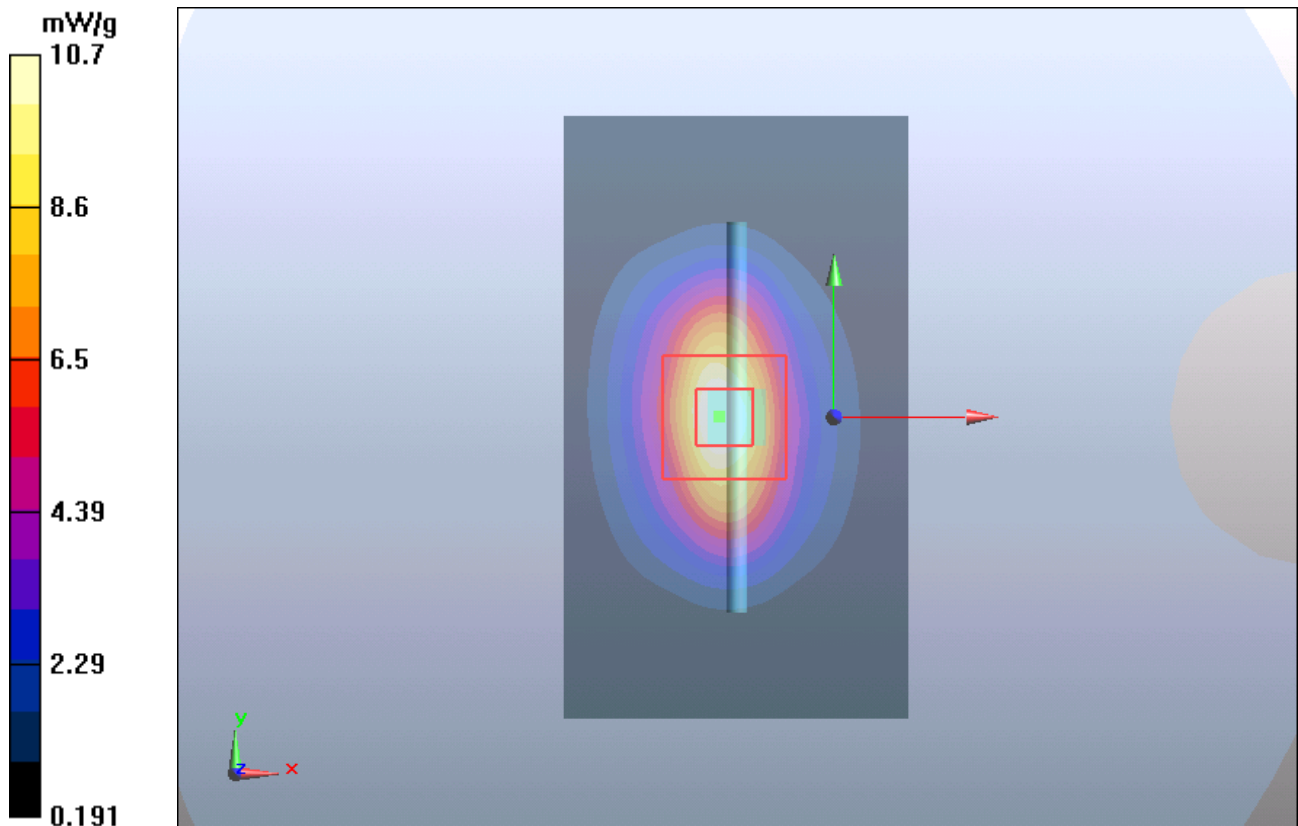

Figure 11 System Performance Check 1900MHz 250mW

TA Technology (Shanghai) Co., Ltd. Test Report

Report No.: RXA1307-0093SAR01R3

Page 70 of 225

System Performance Check at 1900 MHz Body TSL

DUT: Dipole 1900 MHz; Type: D1900V2; Serial: D1900V2 - SN: 5d060

Date/Time: 7/18/2013 11:07:25 AM

Communication System: CW; Frequency: 1900 MHz; Duty Cycle: 1:1

Medium parameters used: $f = 1900$ MHz; $\sigma = 1.524$ mho/m; $\epsilon_r = 52.56$; $\rho = 1000$ kg/m³

Ambient Temperature: 22.3 °C Liquid Temperature: 21.5 °C

Phantom section: Flat Section

DASY5 Configuration:

Sensor-Surface: 4mm (Mechanical Surface Detection)

Probe: EX3DV4 - SN3753; ConvF(7.33, 7.33, 7.33); Calibrated: 1/17/2013

Electronics: DAE4 Sn1317; Calibrated: 1/25/2013

Phantom: SAM1; Type: SAM; Serial: TP-1534

Measurement SW: DASY52, Version 52.8 (2); SEMCAD X Version 14.6.6 (6824)

d=10mm, Pin=250mW/Area Scan (41x71x1): Measurement grid: dx=15mm, dy=15mm

Maximum value of SAR (interpolated) = 12.2 mW/g

d=10mm, Pin=250mW/Zoom Scan (7x7x7)/Cube 0: Measurement grid: dx=5mm, dy=5mm, dz=5mm

Reference Value = 82.3 V/m; Power Drift = 0.068 dB

Peak SAR (extrapolated) = 17.8 W/kg

SAR(1 g) = 9.93 mW/g; SAR(10 g) = 5.25 mW/g

Maximum value of SAR (measured) = 11.3 mW/g

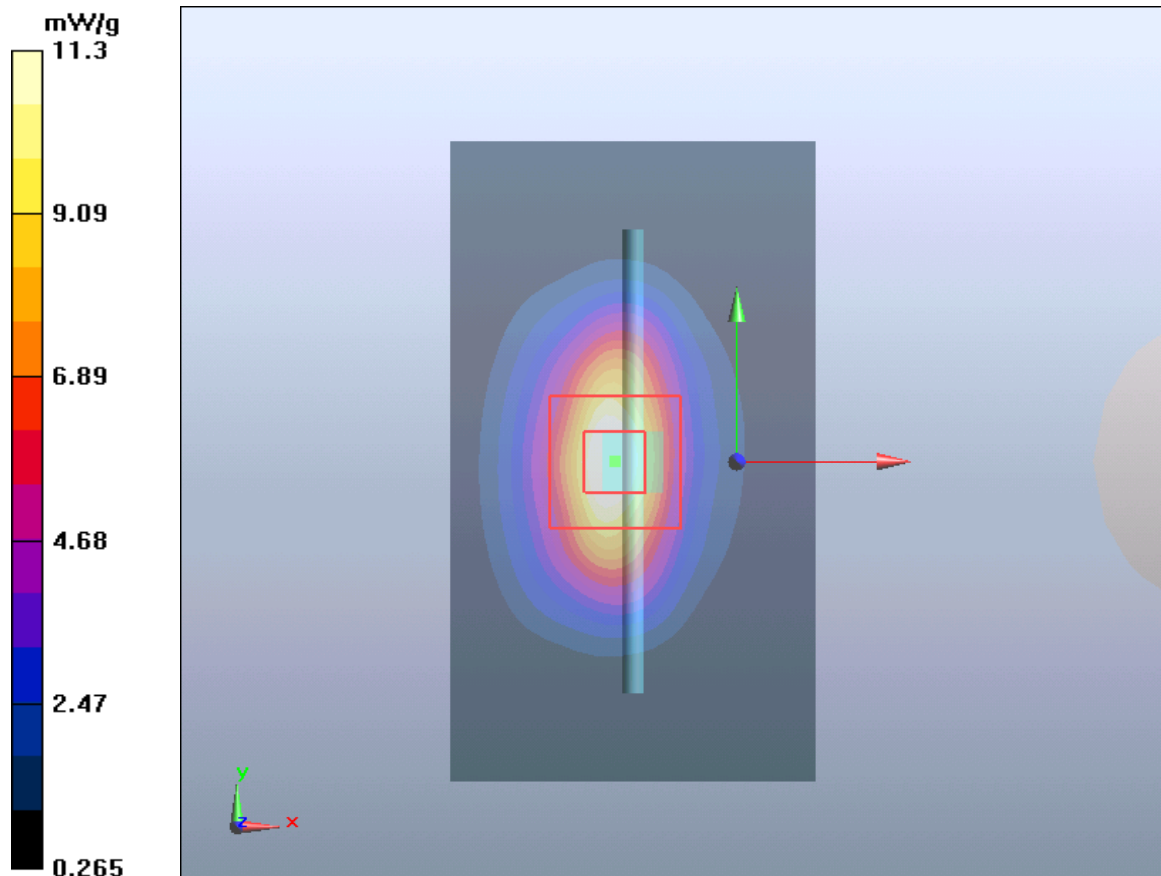

Figure 12 System Performance Check 1900MHz 250mW

TA Technology (Shanghai) Co., Ltd. Test Report

Report No.: RXA1307-0093SAR01R3

Page 71 of 225

System Performance Check at 2450 MHz Head TSL

DUT: Dipole 2450 MHz; Type: D2450V2; Serial: D2450V2 - SN: 786

Date/Time: 7/17/2013 7:20:12 AM

Communication System: CW; Frequency: 2450 MHz; Duty Cycle: 1:1

Medium parameters used: $f = 2450$ MHz; $\sigma = 1.88$ mho/m; $\epsilon_r = 38.32$; $\rho = 1000$ kg/m³

Ambient Temperature: 22.3 °C Liquid Temperature: 21.5 °C

Phantom section: Flat Section

DASY5 Configuration:

Sensor-Surface: 4mm (Mechanical Surface Detection)

Probe: EX3DV4 - SN3753; ConvF(6.86, 6.86, 6.86); Calibrated: 1/17/2013

Electronics: DAE4 Sn1317; Calibrated: 1/25/2013

Phantom: SAM1; Type: SAM; Serial: TP-1534

Measurement SW: DASY52, Version 52.8 (2); SEMCAD X Version 14.6.6 (6824)

d=10mm, Pin=250mW/Area Scan (41x71x1): Measurement grid: dx=12mm, dy=12mm

Maximum value of SAR (interpolated) = 18.2 mW/g

d=10mm, Pin=250mW/Zoom Scan (7x7x7)/Cube 0: Measurement grid: dx=5mm, dy=5mm,

dz=5mm

Reference Value = 88.8 V/m; Power Drift = 0.075 dB

Peak SAR (extrapolated) = 30 W/kg

SAR(1 g) = 13.7 mW/g; SAR(10 g) = 6.22 mW/g

Maximum value of SAR (measured) = 15.9 mW/g

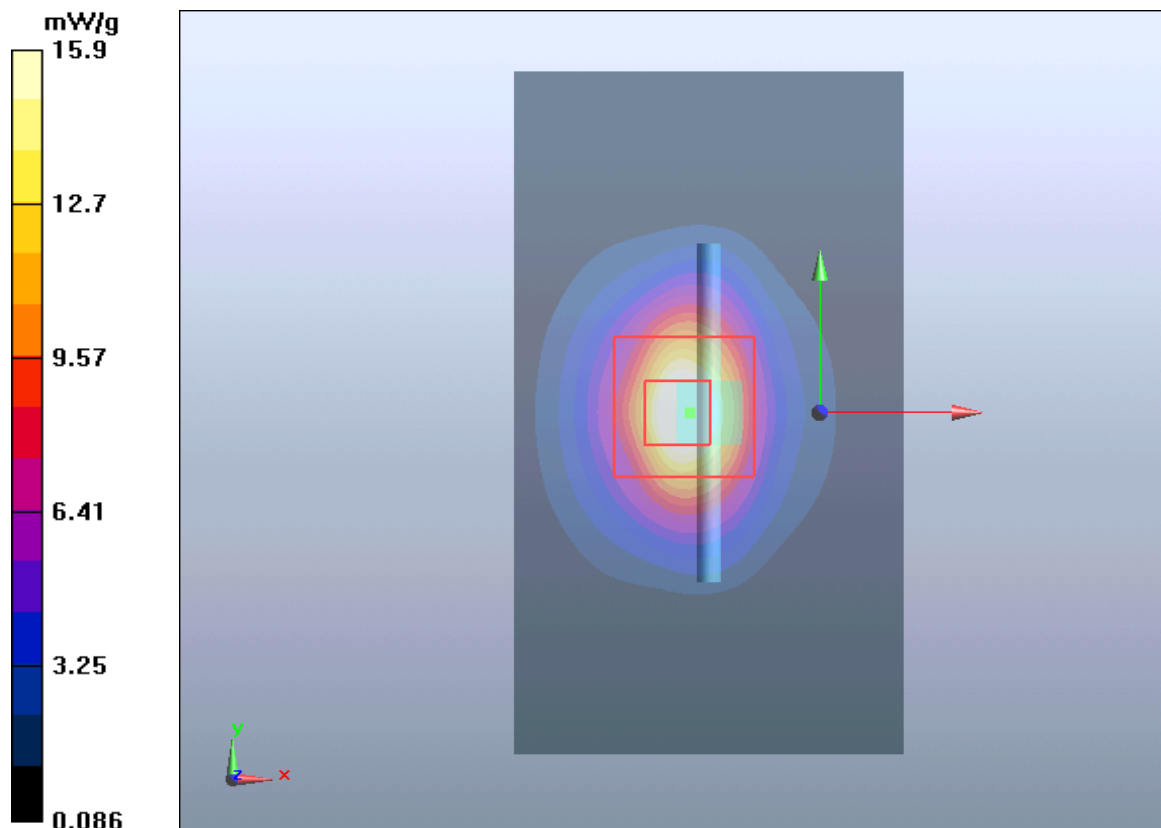

Figure 13 System Performance Check 2450MHz 250mW

TA Technology (Shanghai) Co., Ltd. Test Report

Report No.: RXA1307-0093SAR01R3

Page 72 of 225

System Performance Check at 2450 MHz Body TSL

DUT: Dipole 2450 MHz; Type: D2450V2; Serial: D2450V2 - SN: 786

Date/Time: 7/19/2013 5:10:59 PM

Communication System: CW; Frequency: 2450 MHz; Duty Cycle: 1:1

Medium parameters used: $f = 2450$ MHz; $\sigma = 1.903$ mho/m; $\epsilon_r = 51.69$; $\rho = 1000$ kg/m³

Ambient Temperature: 22.3 °C Liquid Temperature: 21.5 °C

Phantom section: Flat Section

DASY5 Configuration:

Sensor-Surface: 4mm (Mechanical Surface Detection)

Probe: EX3DV4 - SN3753; ConvF(6.90, 6.90, 6.90); Calibrated: 1/17/2013

Electronics: DAE4 Sn1317; Calibrated: 1/25/2013

Phantom: SAM1; Type: SAM; Serial: TP-1534

Measurement SW: DASY52, Version 52.8 (2); SEMCAD X Version 14.6.6 (6824)

d=10mm, Pin=250mW/Area Scan (41x71x1): Measurement grid: dx=12mm, dy=12mm

Maximum value of SAR (interpolated) = 16 mW/g

d=10mm, Pin=250mW/Zoom Scan (7x7x7)/Cube 0: Measurement grid: dx=5mm, dy=5mm, dz=5mm

Reference Value = 81.2 V/m; Power Drift = 0.003 dB

Peak SAR (extrapolated) = 25.4 W/kg

SAR(1 g) = 12.5 mW/g; SAR(10 g) = 6.20 mW/g

Maximum value of SAR (measured) = 14.4 mW/g

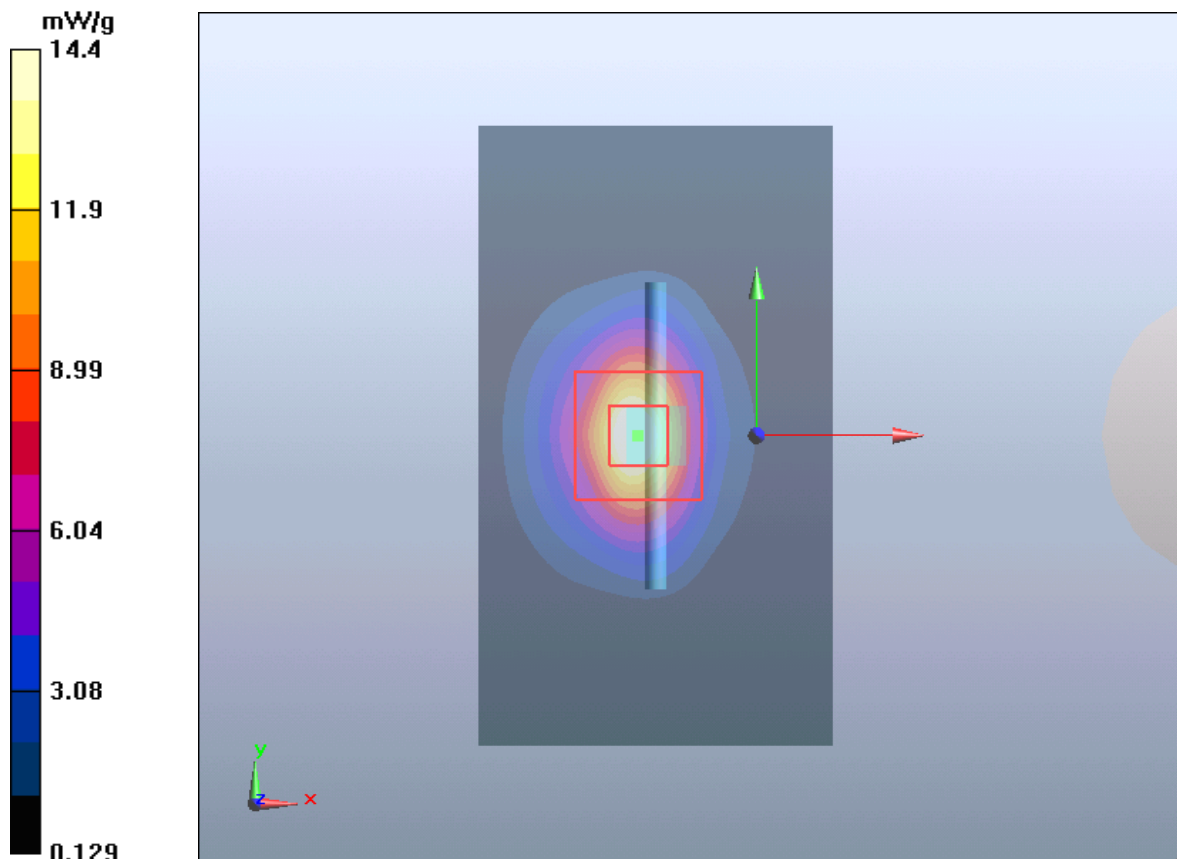

Figure 14 System Performance Check 2450MHz 250mW

TA Technology (Shanghai) Co., Ltd. Test Report

Report No.: RXA1307-0093SAR01R3

Page 73 of 225

System Performance Check at 2450 MHz Body TSL

DUT: Dipole 2450 MHz; Type: D2450V2; Serial: D2450V2 - SN: 786

Date/Time: 8/1/2013 1:20:59 PM

Communication System: CW; Frequency: 2450 MHz; Duty Cycle: 1:1

Medium parameters used: $f = 2450$ MHz; $\sigma = 1.901$ mho/m; $\epsilon_r = 51.65$; $\rho = 1000$ kg/m³

Ambient Temperature: 22.3 °C Liquid Temperature: 21.5 °C

Phantom section: Flat Section

DASY5 Configuration:

Sensor-Surface: 4mm (Mechanical Surface Detection)

Probe: EX3DV4 - SN3753; ConvF(6.90, 6.90, 6.90); Calibrated: 1/17/2013

Electronics: DAE4 Sn1317; Calibrated: 1/25/2013

Phantom: SAM1; Type: SAM; Serial: TP-1534

Measurement SW: DASY52, Version 52.8 (2); SEMCAD X Version 14.6.6 (6824)

d=10mm, Pin=250mW/Area Scan (41x71x1): Measurement grid: dx=12mm, dy=12mm

Maximum value of SAR (interpolated) = 16 mW/g

d=10mm, Pin=250mW/Zoom Scan (7x7x7)/Cube 0: Measurement grid: dx=5mm, dy=5mm, dz=5mm

Reference Value = 81.4 V/m; Power Drift = 0.005 dB

Peak SAR (extrapolated) = 25.7 W/kg

SAR(1 g) = 12.4 mW/g; SAR(10 g) = 6.20 mW/g

Maximum value of SAR (measured) = 14.9 mW/g

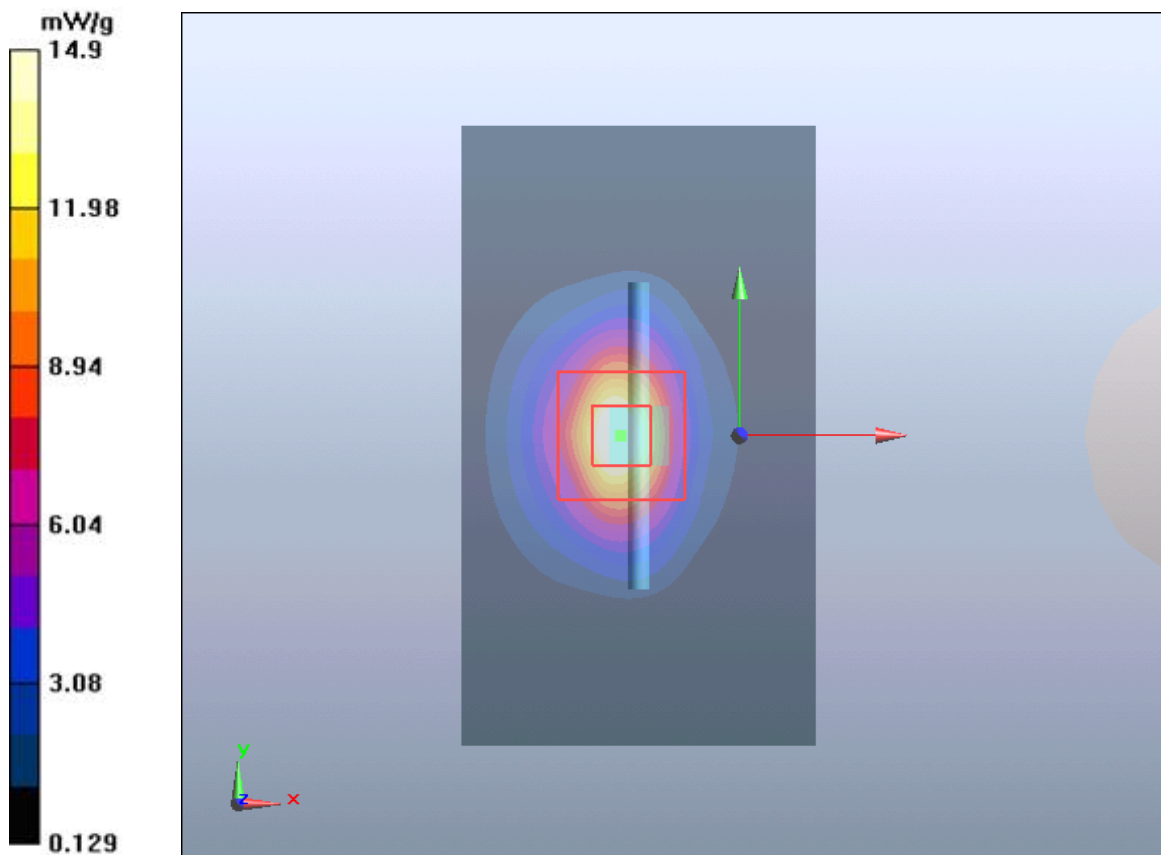

Figure 15 System Performance Check 2450MHz 250mW

ANNEX C: Graph Results

GSM 850 Left Cheek Middle

Date/Time: 7/20/2013 5:28:35 PM

Communication System: GSM; Frequency: 836.6 MHz; Duty Cycle: 1:8.30042

Medium parameters used: $f = 837$ MHz; $\sigma = 0.918$ mho/m; $\epsilon_r = 41.233$; $\rho = 1000$ kg/m³

Ambient Temperature: 22.3 °C Liquid Temperature: 21.5 °C

Phantom section: Left Section

DASY5 Configuration:

Sensor-Surface: 4mm (Mechanical Surface Detection)

Probe: EX3DV4 - SN3753; ConvF(8.95, 8.95, 8.95); Calibrated: 1/17/2013;

Electronics: DAE4 Sn1317; Calibrated: 1/25/2013

Phantom: SAM1; Type: SAM; Serial: TP-1534

Measurement SW: DASY52, Version 52.8 (2); SEMCAD X Version 14.6.6 (6824)

Left Cheek Middle/Area Scan (7x12x1): Measurement grid: dx=15mm, dy=15mm

Maximum value of SAR (measured) = 0.00498 W/kg

Left Cheek Middle/Zoom Scan (5x5x7)/Cube 0: Measurement grid: dx=8mm, dy=8mm, dz=5mm

Reference Value = 0.753 V/m; Power Drift = 0.047 dB

Peak SAR (extrapolated) = 0.00886 mW/g

SAR(1 g) = 0.0053 mW/g; SAR(10 g) = 0.00389 mW/g

Maximum value of SAR (measured) = 0.00546 W/kg

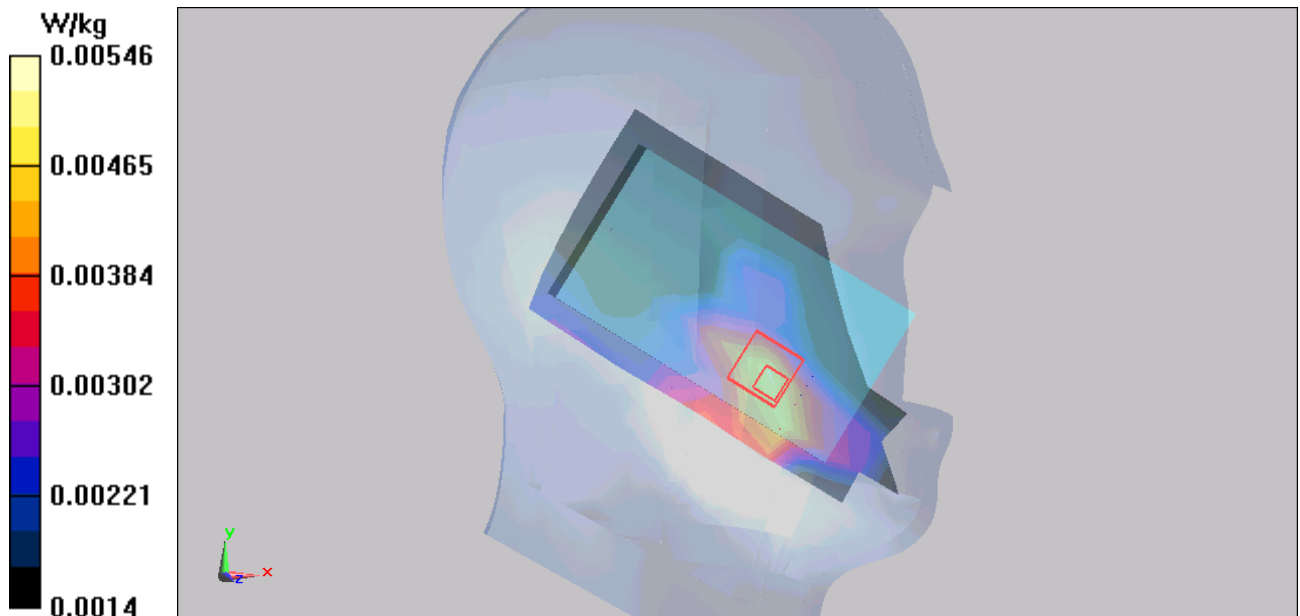

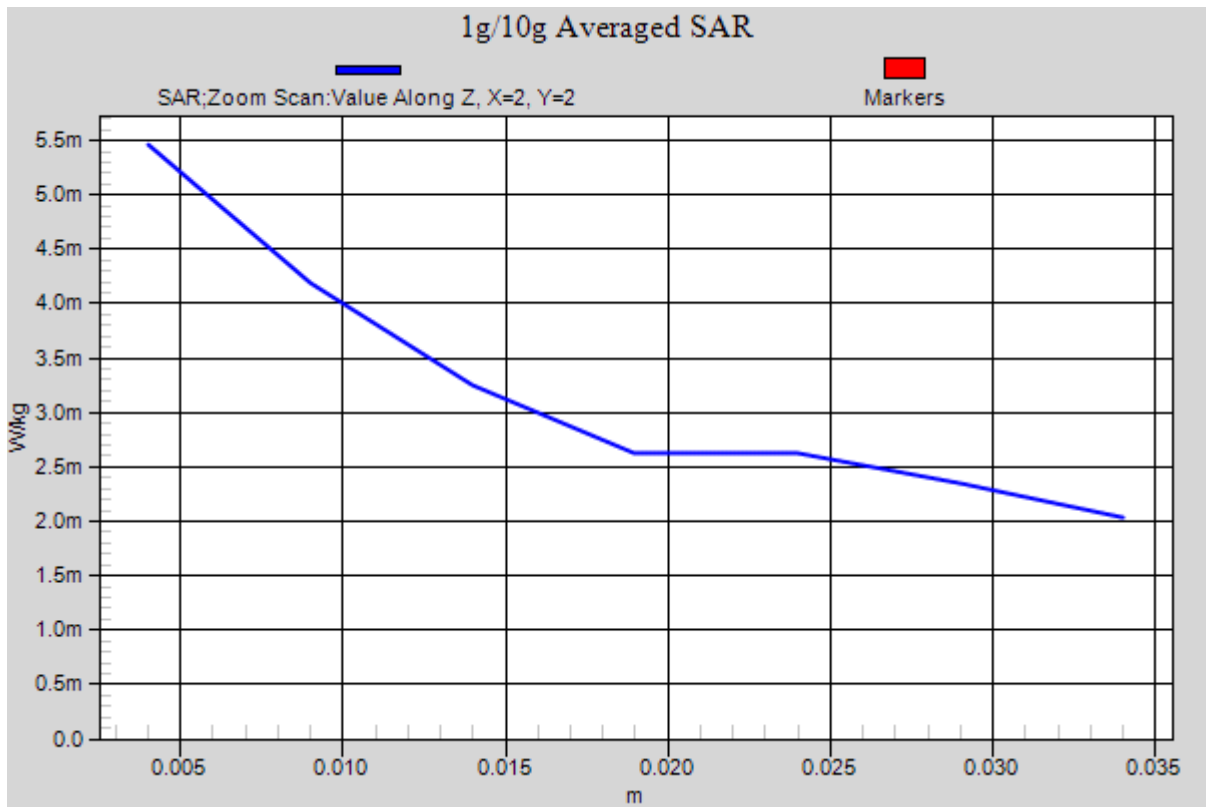

Figure 16 Left Hand Touch Cheek GSM 850 Channel 190

TA Technology (Shanghai) Co., Ltd. Test Report

Report No.: RXA1307-0093SAR01R3

Page 76 of 225

GSM 850 Left Tilt Middle

Date/Time: 7/20/2013 5:45:09 PM

Communication System: GSM; Frequency: 836.6 MHz; Duty Cycle: 1:8.30042

Medium parameters used: $f = 837$ MHz; $\sigma = 0.918$ mho/m; $\epsilon_r = 41.233$; $\rho = 1000$ kg/m³

Ambient Temperature: 22.3 °C Liquid Temperature: 21.5 °C

Phantom section: Left Section

DASY5 Configuration:

Sensor-Surface: 4mm (Mechanical Surface Detection)

Probe: EX3DV4 - SN3753; ConvF(8.95, 8.95, 8.95); Calibrated: 1/17/2013;

Electronics: DAE4 Sn1317; Calibrated: 1/25/2013

Phantom: SAM1; Type: SAM; Serial: TP-1534

Measurement SW: DASY52, Version 52.8 (2); SEMCAD X Version 14.6.6 (6824)

Left Tilt Middle/Area Scan (7x12x1): Measurement grid: dx=15mm, dy=15mm

Maximum value of SAR (measured) = 0.00399 W/kg

Left Tilt Middle/Zoom Scan (5x5x7)/Cube 0: Measurement grid: dx=8mm, dy=8mm, dz=5mm

Reference Value = 1.293 V/m; Power Drift = -0.087 dB

Peak SAR (extrapolated) = 0.00464 mW/g

SAR(1 g) = 0.0024 mW/g; SAR(10 g) = 0.00133 mW/g

Maximum value of SAR (measured) = 0.00233 W/kg

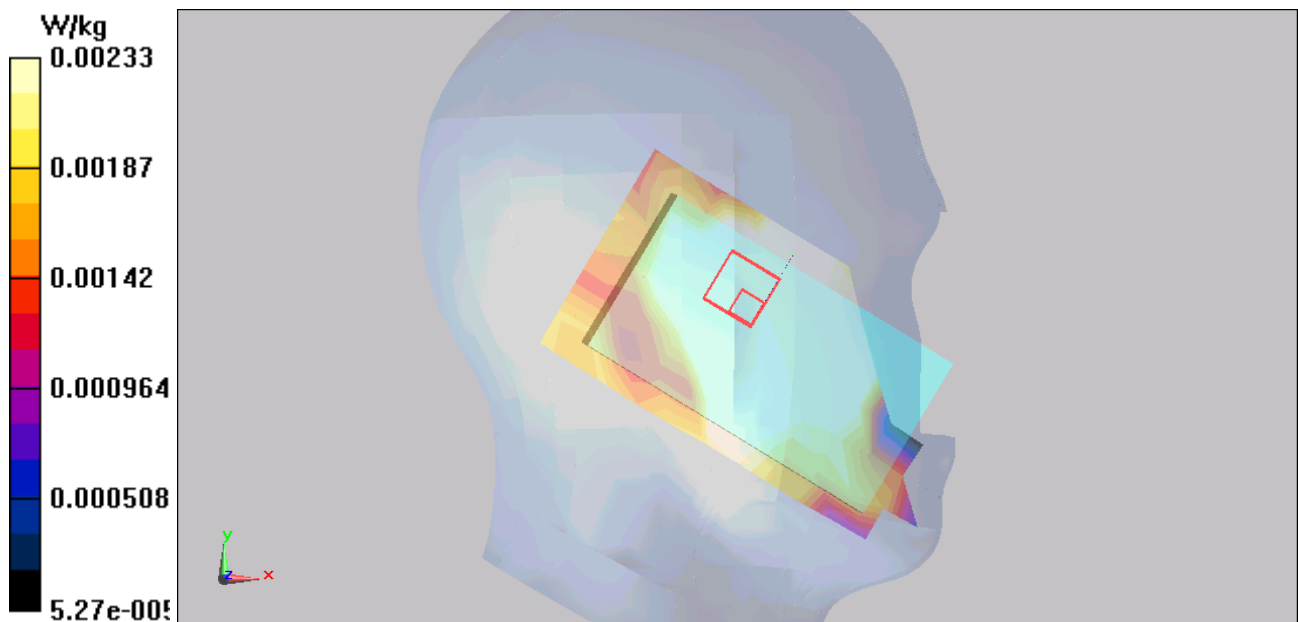

Figure 17 Left Hand Tilt 15° GSM 850 Channel 190

TA Technology (Shanghai) Co., Ltd.
Test Report

Report No.: RXA1307-0093SAR01R3

Page 77 of 225

GSM 850 Right Cheek Middle

Date/Time: 7/20/2013 4:52:48 PM

Communication System: GSM; Frequency: 836.6 MHz; Duty Cycle: 1:8.30042

Medium parameters used: $f = 837$ MHz; $\sigma = 0.918$ mho/m; $\epsilon_r = 41.233$; $\rho = 1000$ kg/m³

Ambient Temperature: 22.3 °C Liquid Temperature: 21.5 °C

Phantom section: Right Section

DASY5 Configuration:

Sensor-Surface: 4mm (Mechanical Surface Detection)

Probe: EX3DV4 - SN3753; ConvF(8.95, 8.95, 8.95); Calibrated: 1/17/2013;

Electronics: DAE4 Sn1317; Calibrated: 1/25/2013

Phantom: SAM1; Type: SAM; Serial: TP-1534

Measurement SW: DASY52, Version 52.8 (2); SEMCAD X Version 14.6.6 (6824)

Right Cheek Middle/Area Scan (7x12x1): Measurement grid: dx=15mm, dy=15mm

Maximum value of SAR (measured) = 0.00478 W/kg

Right Cheek Middle/Zoom Scan (5x5x7)/Cube 0: Measurement grid: dx=8mm, dy=8mm, dz=5mm

Reference Value = 1.162 V/m; Power Drift = -0.028 dB

Peak SAR (extrapolated) = 0.00646 mW/g

SAR(1 g) = 0.0021 mW/g; SAR(10 g) = 0.00145 mW/g

Maximum value of SAR (measured) = 0.00230 W/kg

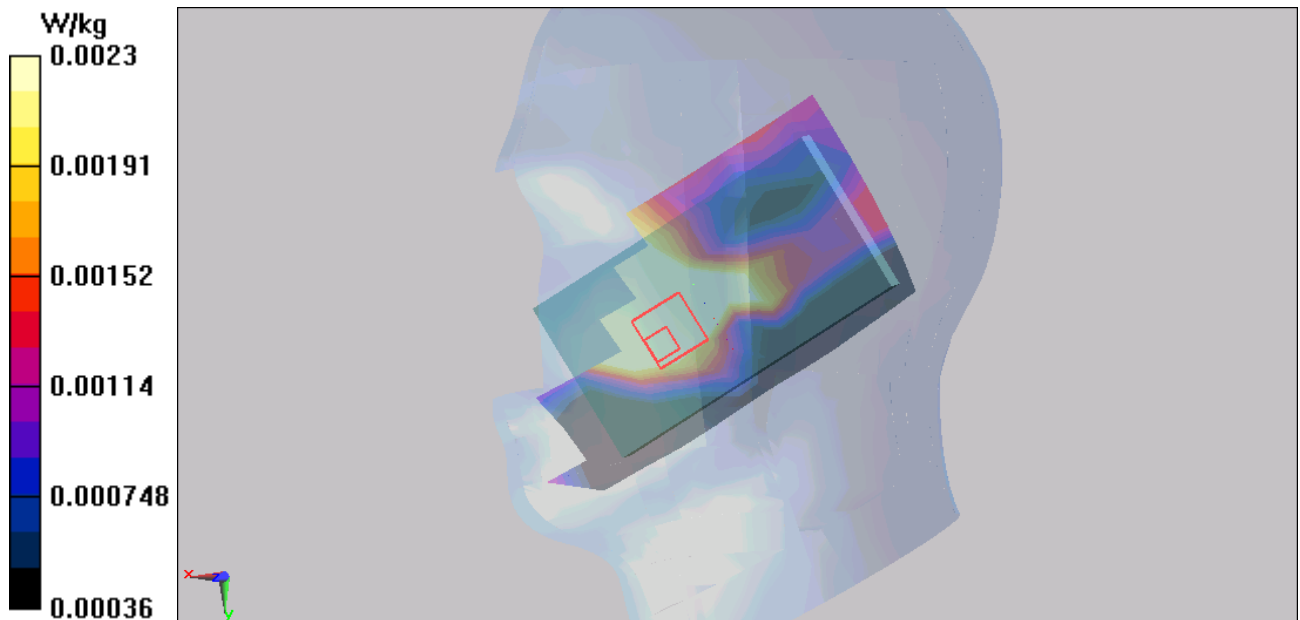

Figure 18 Right Hand Touch Cheek GSM 850 Channel 190

GSM 850 Right Tilt Middle

Date/Time: 7/20/2013 5:08:57 PM

Communication System: GSM; Frequency: 836.6 MHz; Duty Cycle: 1:8.30042

Medium parameters used: $f = 837$ MHz; $\sigma = 0.918$ mho/m; $\epsilon_r = 41.233$; $\rho = 1000$ kg/m³

Ambient Temperature: 22.3 °C Liquid Temperature: 21.5 °C

Phantom section: Right Section

DASY5 Configuration:

Sensor-Surface: 4mm (Mechanical Surface Detection)

Probe: EX3DV4 - SN3753; ConvF(8.95, 8.95, 8.95); Calibrated: 1/17/2013;

Electronics: DAE4 Sn1317; Calibrated: 1/25/2013

Phantom: SAM1; Type: SAM; Serial: TP-1534

Measurement SW: DASY52, Version 52.8 (2); SEMCAD X Version 14.6.6 (6824)

Right Tilt Middle/Area Scan (7x12x1): Measurement grid: dx=15mm, dy=15mm

Maximum value of SAR (measured) = 0.00248 W/kg

Right Tilt Middle/Zoom Scan (5x5x7)/Cube 0: Measurement grid: dx=8mm, dy=8mm, dz=5mm

Reference Value = 0.804 V/m; Power Drift = 0.173 dB

Peak SAR (extrapolated) = 0.00531 mW/g

SAR(1 g) = 0.0018 mW/g; SAR(10 g) = 0.00124 mW/g

Maximum value of SAR (measured) = 0.00186 W/kg

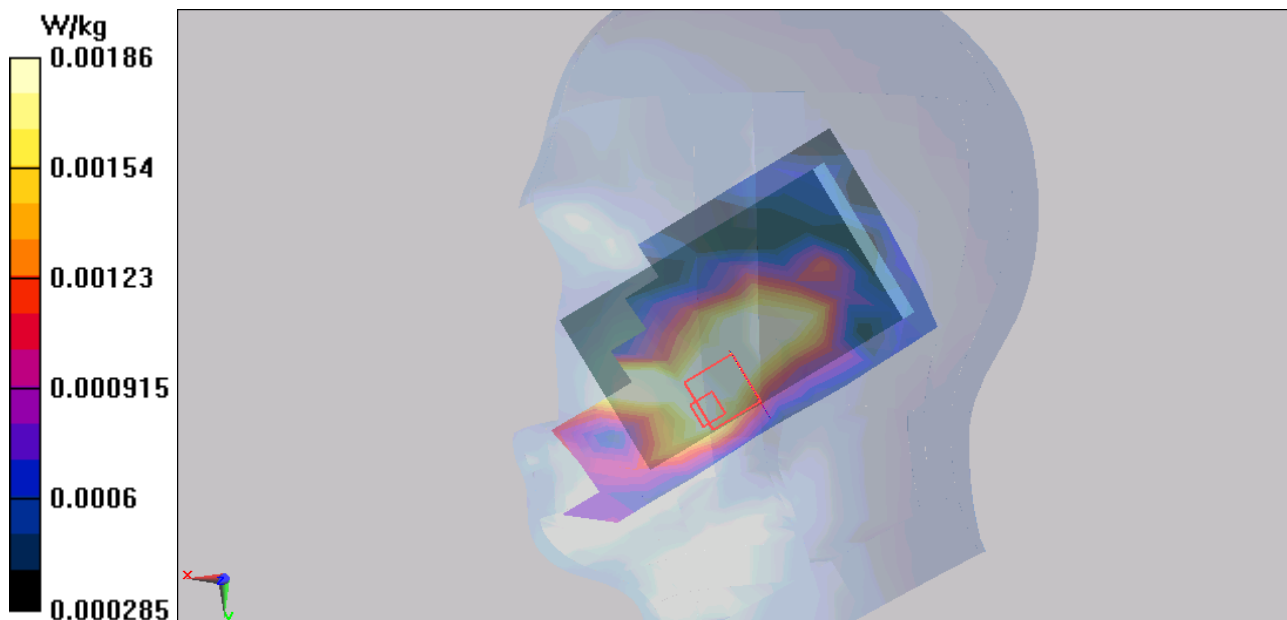

Figure 19 Right Hand Tilt 15° GSM 850 Channel 190

TA Technology (Shanghai) Co., Ltd. Test Report

Report No.: RXA1307-0093SAR01R3

Page 79 of 225

GSM 850 GPRS (3Txslots) Back Side Middle

Date/Time: 7/20/2013 10:49:09 AM

Communication System: GPRS 3TX; Frequency: 836.6 MHz; Duty Cycle: 1:2.76694

Medium parameters used: $f = 837$ MHz; $\sigma = 1.014$ mho/m; $\epsilon_r = 54.339$; $\rho = 1000$ kg/m³

Ambient Temperature: 22.3 °C Liquid Temperature: 21.5 °C

Phantom section: Flat Section

DASY5 Configuration:

Sensor-Surface: 4mm (Mechanical Surface Detection)

Probe: EX3DV4 - SN3753; ConvF(9.05, 9.05, 9.05); Calibrated: 1/17/2013;

Electronics: DAE4 Sn1317; Calibrated: 1/25/2013

Phantom: SAM1; Type: SAM; Serial: TP-1534

Measurement SW: DASY52, Version 52.8 (2); SEMCAD X Version 14.6.6 (6824)

Back Side Middle /Area Scan (7x11x1): Measurement grid: dx=15mm, dy=15mm

Maximum value of SAR (measured) = 0.0307 W/kg

Back Side Middle /Zoom Scan (5x5x7)/Cube 0: Measurement grid: dx=8mm, dy=8mm, dz=5mm

Reference Value = 4.706 V/m; Power Drift = 0.032 dB

Peak SAR (extrapolated) = 0.041 mW/g

SAR(1 g) = 0.0295 mW/g; SAR(10 g) = 0.021 mW/g

Maximum value of SAR (measured) = 0.0316 W/kg

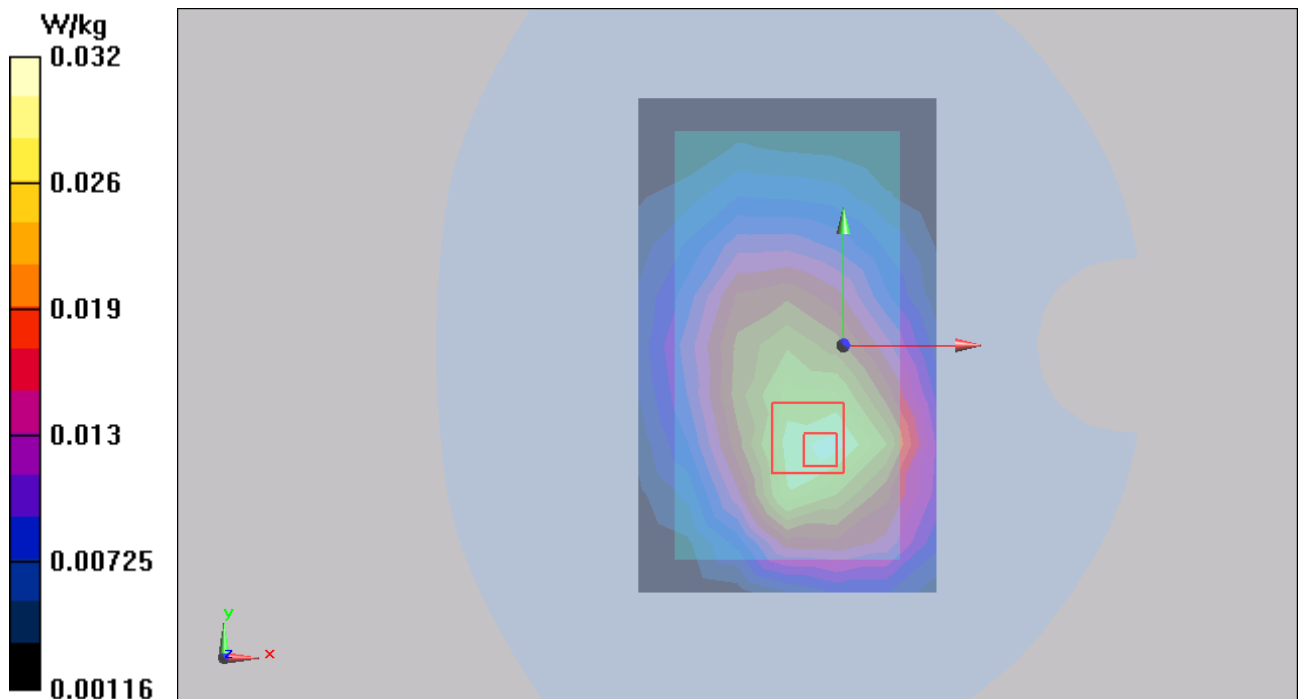

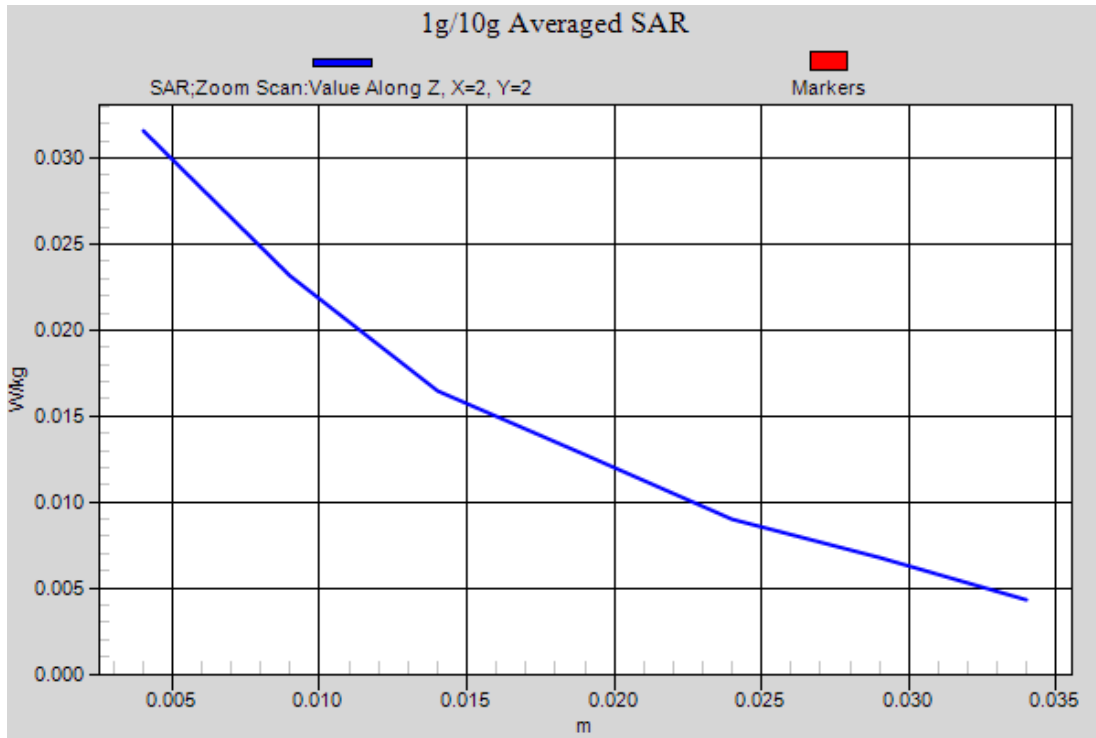

Figure 20 Body, Back Side, GSM 850 GPRS (3Txslots) Channel 190

TA Technology (Shanghai) Co., Ltd. Test Report

Report No.: RXA1307-0093SAR01R3

Page 81 of 225

GSM 850 GPRS (3Txslots) Front Side Middle

Date/Time: 7/20/2013 10:10:21 AM

Communication System: GPRS 3TX; Frequency: 836.6 MHz; Duty Cycle: 1:2.76694

Medium parameters used: $f = 837$ MHz; $\sigma = 1.014$ mho/m; $\epsilon_r = 54.339$; $\rho = 1000$ kg/m³

Ambient Temperature: 22.3 °C Liquid Temperature: 21.5 °C

Phantom section: Flat Section

DASY5 Configuration:

Sensor-Surface: 4mm (Mechanical Surface Detection)

Probe: EX3DV4 - SN3753; ConvF(9.05, 9.05, 9.05); Calibrated: 1/17/2013;

Electronics: DAE4 Sn1317; Calibrated: 1/25/2013

Phantom: SAM1; Type: SAM; Serial: TP-1534

Measurement SW: DASY52, Version 52.8 (2); SEMCAD X Version 14.6.6 (6824)

Front Side Middle/Area Scan (61x101x1): Interpolated grid: dx=15 mm, dy=15 mm

Maximum value of SAR (interpolated) = 0.0165 W/kg

Front Side Middle/Zoom Scan (5x5x7)/Cube 0: Measurement grid: dx=8mm, dy=8mm, dz=5mm

Reference Value = 2.859 V/m; Power Drift = 0.01 dB

Peak SAR (extrapolated) = 0.025 mW/g

SAR(1 g) = 0.0152 mW/g; SAR(10 g) = 0.00962 mW/g

Maximum value of SAR (measured) = 0.0165 W/kg

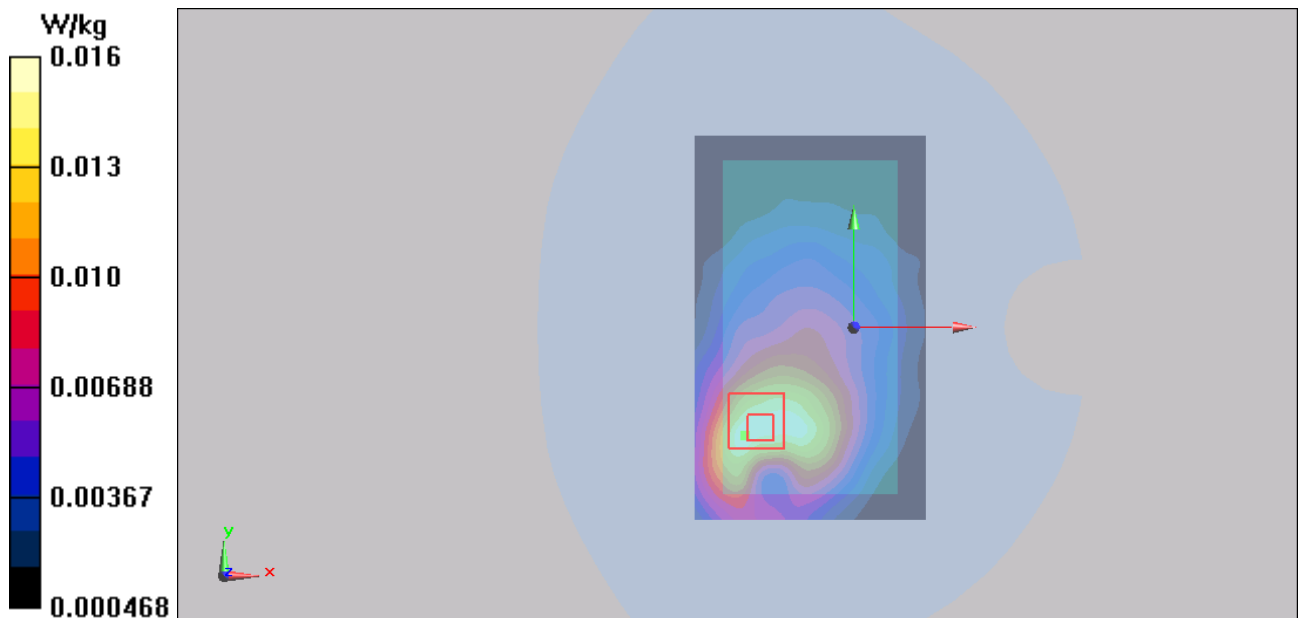

Figure 21 Body, Front Side, GSM 850 GPRS (3Txslots) Channel 190

GSM 850 GPRS (3Txslots) Left Edge Middle

Date/Time: 7/20/2013 10:31:48 AM

Communication System: GPRS 3TX; Frequency: 836.6 MHz; Duty Cycle: 1:2.76694

Medium parameters used: $f = 837$ MHz; $\sigma = 1.014$ mho/m; $\epsilon_r = 54.339$; $\rho = 1000$ kg/m³

Ambient Temperature: 22.3 °C Liquid Temperature: 21.5 °C

Phantom section: Flat Section

DASY5 Configuration:

Sensor-Surface: 4mm (Mechanical Surface Detection)

Probe: EX3DV4 - SN3753; ConvF(9.05, 9.05, 9.05); Calibrated: 1/17/2013;

Electronics: DAE4 Sn1317; Calibrated: 1/25/2013

Phantom: SAM1; Type: SAM; Serial: TP-1534

Measurement SW: DASY52, Version 52.8 (2); SEMCAD X Version 14.6.6 (6824)

Left Edge Middle /Area Scan (31x111x1): Interpolated grid: dx=15 mm, dy=15 mm

Maximum value of SAR (interpolated) = 0.00709 W/kg

Left Edge Middle /Zoom Scan (5x5x7)/Cube 0: Measurement grid: dx=8mm, dy=8mm, dz=5mm

Reference Value = 2.607 V/m; Power Drift = 0.031 dB

Peak SAR (extrapolated) = 0.00915 mW/g

SAR(1 g) = 0.0067 mW/g; SAR(10 g) = 0.00442 mW/g

Maximum value of SAR (measured) = 0.00719 W/kg

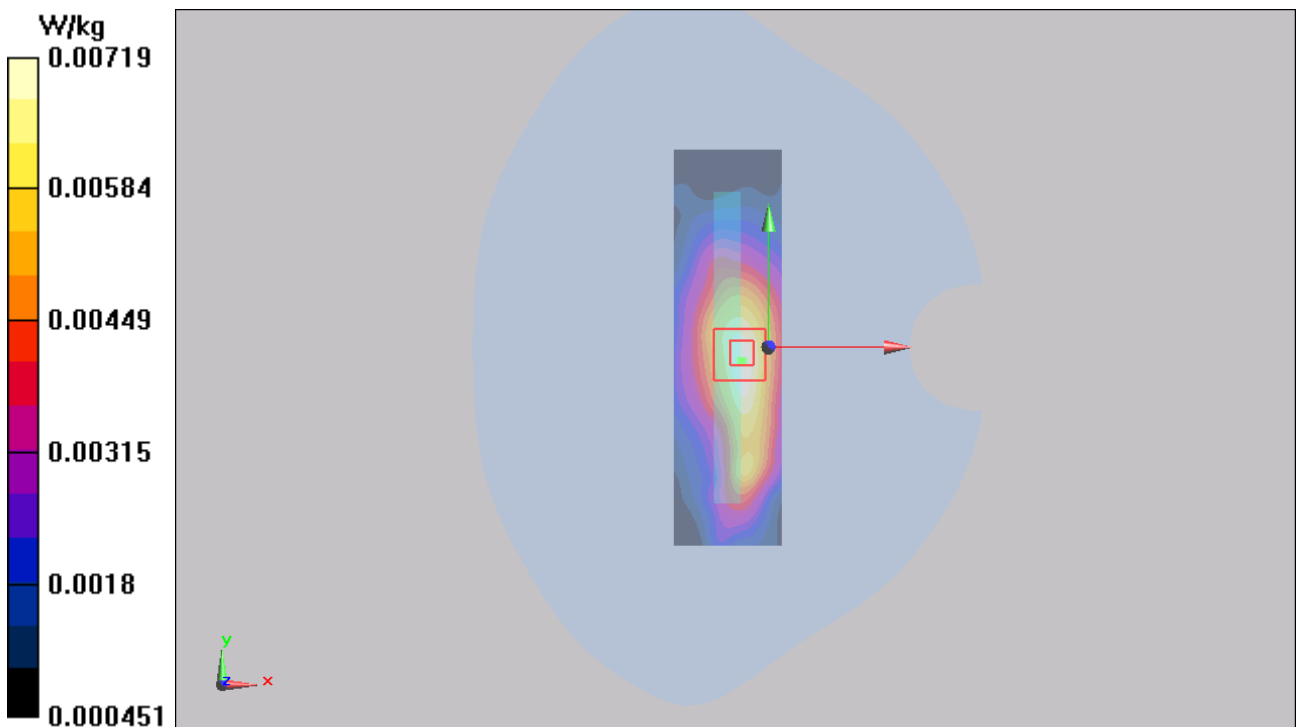

Figure 22 Body, Left Edge, GSM 850 GPRS (3Txslots) Channel 190

GSM 850 GPRS (3Txslots) Right Edge Middle

Date/Time: 7/20/2013 9:46:53 AM

Communication System: GPRS 3TX; Frequency: 836.6 MHz; Duty Cycle: 1:2.76694

Medium parameters used: $f = 837$ MHz; $\sigma = 1.014$ mho/m; $\epsilon_r = 54.339$; $\rho = 1000$ kg/m³

Ambient Temperature: 22.3 °C Liquid Temperature: 21.5 °C

Phantom section: Flat Section

DASY5 Configuration:

Sensor-Surface: 4mm (Mechanical Surface Detection)

Probe: EX3DV4 - SN3753; ConvF(9.05, 9.05, 9.05); Calibrated: 1/17/2013;

Electronics: DAE4 Sn1317; Calibrated: 1/25/2013

Phantom: SAM1; Type: SAM; Serial: TP-1534

Measurement SW: DASY52, Version 52.8 (2); SEMCAD X Version 14.6.6 (6824)

Right Edge Middle /Area Scan (31x111x1): Interpolated grid: dx=15 mm, dy=15 mm

Maximum value of SAR (interpolated) = 0.0117 W/kg

Right Edge Middle /Zoom Scan (5x5x7)/Cube 0: Measurement grid: dx=8mm, dy=8mm, dz=5mm

Reference Value = 3.384 V/m; Power Drift = 0.038 dB

Peak SAR (extrapolated) = 0.015 mW/g

SAR(1 g) = 0.0105 mW/g; SAR(10 g) = 0.00721 mW/g

Maximum value of SAR (measured) = 0.0112 W/kg

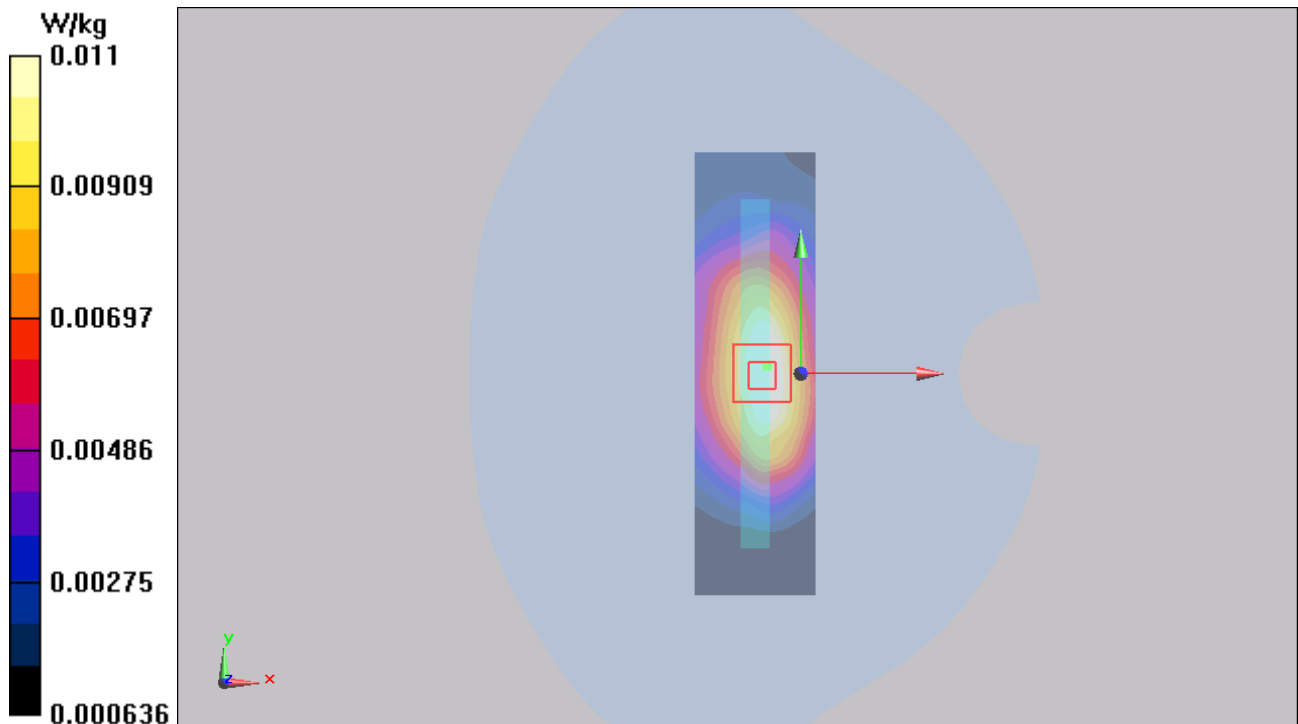

Figure 23 Body, Right Edge, GSM 850 GPRS (3Txslots) Channel 190

GSM 850 GPRS (3Txslots) Bottom Edge Middle

Date/Time: 7/20/2013 12:02:34 AM

Communication System: GPRS 3TX; Frequency: 836.6 MHz; Duty Cycle: 1:2.76694

Medium parameters used: $f = 837$ MHz; $\sigma = 1.014$ mho/m; $\epsilon_r = 54.339$; $\rho = 1000$ kg/m³

Ambient Temperature: 22.3 °C Liquid Temperature: 21.5 °C

Phantom section: Flat Section

DASY5 Configuration:

Sensor-Surface: 4mm (Mechanical Surface Detection)

Probe: EX3DV4 - SN3753; ConvF(9.05, 9.05, 9.05); Calibrated: 1/17/2013;

Electronics: DAE4 Sn1317; Calibrated: 1/25/2013

Phantom: SAM1; Type: SAM; Serial: TP-1534

Measurement SW: DASY52, Version 52.8 (2); SEMCAD X Version 14.6.6 (6824)

Bottom Edge Middle /Area Scan (31x61x1): Interpolated grid: dx=15 mm, dy=15 mm

Maximum value of SAR (interpolated) = 0.0101 W/kg

Bottom Edge Middle /Zoom Scan (5x5x7)/Cube 0: Measurement grid: dx=8mm, dy=8mm, dz=5mm

Reference Value = 2.420 V/m; Power Drift = 0.050 dB

Peak SAR (extrapolated) = 0.017 mW/g

SAR(1 g) = 0.0088 mW/g; SAR(10 g) = 0.00449 mW/g

Maximum value of SAR (measured) = 0.00880 W/kg

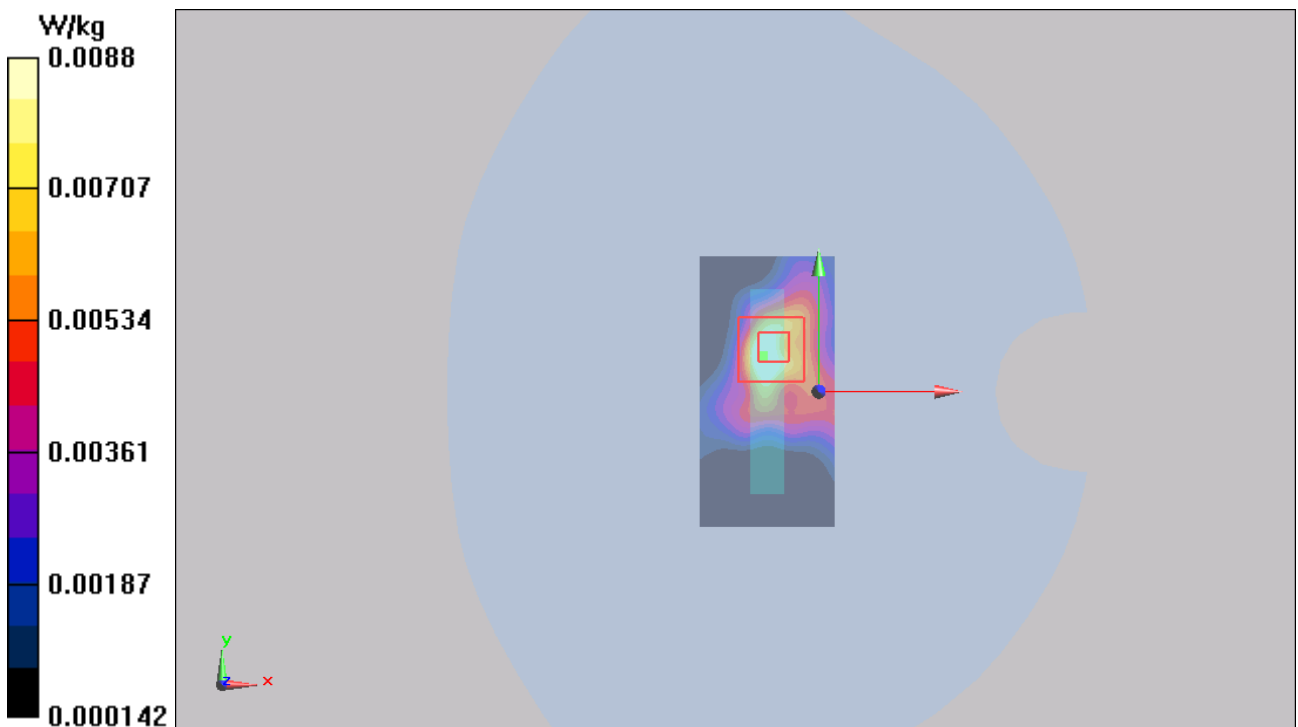

Figure 24 Body, Bottom Edge, GSM 850 GPRS (TX slot) Channel 190

TA Technology (Shanghai) Co., Ltd. Test Report

Report No.: RXA1307-0093SAR01R3

Page 85 of 225

GSM 1900 Left Cheek Middle

Date/Time: 7/18/2013 5:32:12 AM

Communication System: GSM; Frequency: 1880 MHz; Duty Cycle: 1:8.30042

Medium parameters used: $f = 1880$ MHz; $\sigma = 1.431$ mho/m; $\epsilon_r = 38.381$; $\rho = 1000$ kg/m³

Ambient Temperature: 22.3 °C Liquid Temperature: 21.5 °C

Phantom section: Left Section

DASY5 Configuration:

Sensor-Surface: 4mm (Mechanical Surface Detection)

Probe: EX3DV4 - SN3753; ConvF(7.63, 7.63, 7.63); Calibrated: 1/17/2013;

Electronics: DAE4 Sn1317; Calibrated: 1/25/2013

Phantom: SAM 2; Type: SAM;

Measurement SW: DASY52, Version 52.8 (2); SEMCAD X Version 14.6.6 (6824)

Left Cheek Middle/Area Scan (7x12x1): Measurement grid: dx=15mm, dy=15mm

Maximum value of SAR (measured) = 0.265 W/kg

Left Cheek Middle/Zoom Scan (5x5x7)/Cube 0: Measurement grid: dx=8mm, dy=8mm, dz=5mm

Reference Value = 5.687 V/m; Power Drift = -0.05 dB

Peak SAR (extrapolated) = 0.442 mW/g

SAR(1 g) = 0.282 mW/g; SAR(10 g) = 0.175 mW/g

Maximum value of SAR (measured) = 0.302 W/kg

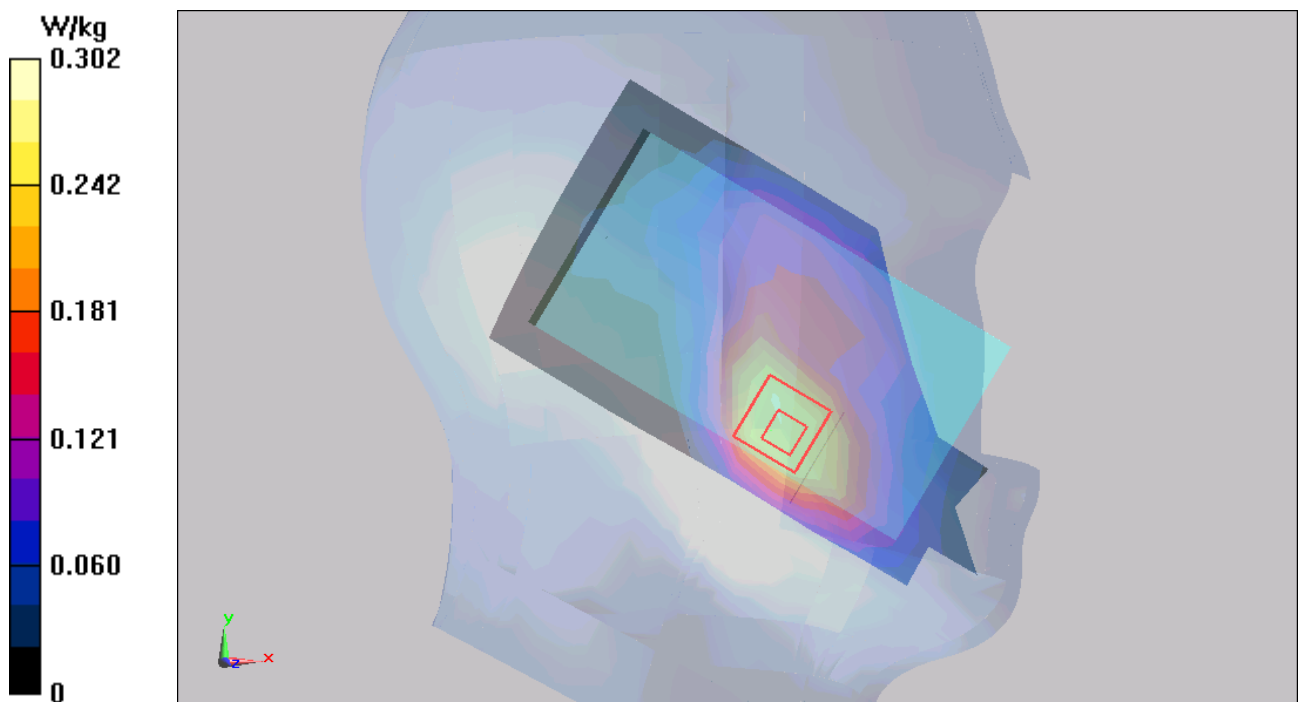

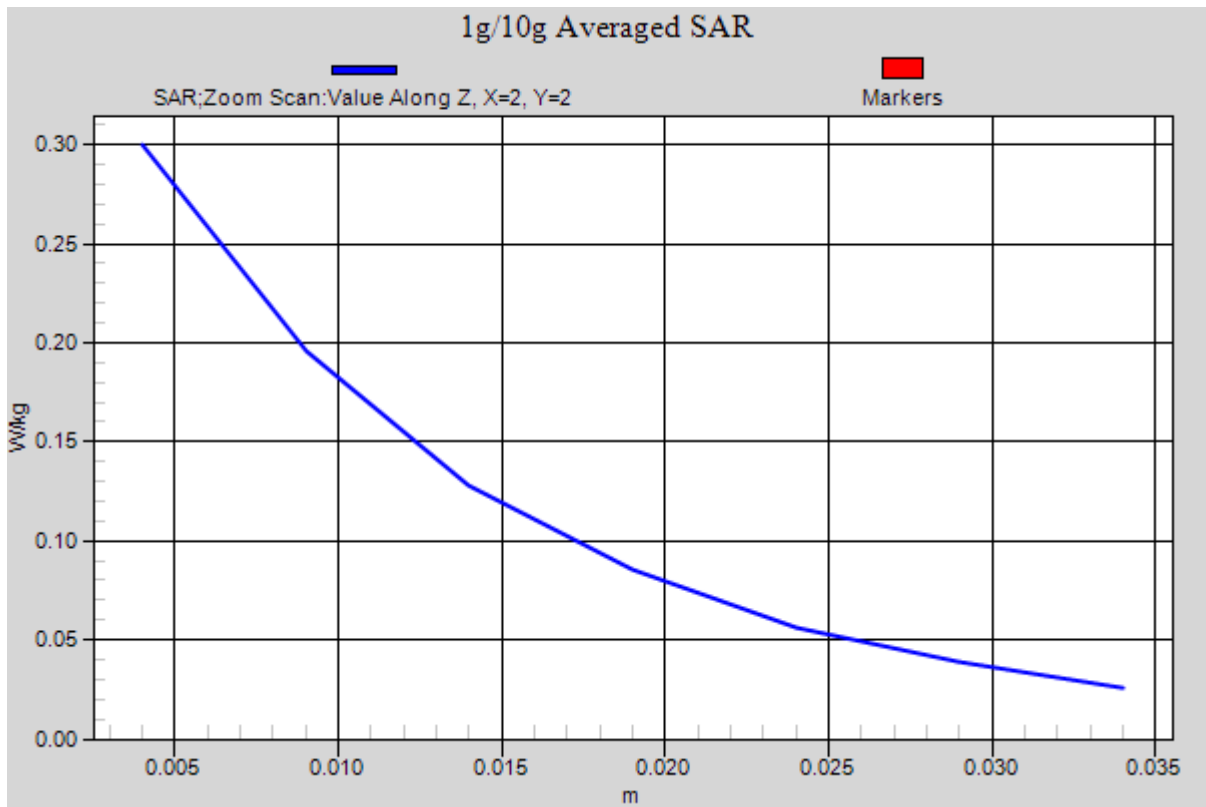

Figure 25 Left Hand Touch Cheek GSM 1900 Channel 661

GSM 1900 Left Tilt Middle

Date/Time: 7/18/2013 5:49:12 AM

Communication System: GSM; Frequency: 1880 MHz; Duty Cycle: 1:8.30042

Medium parameters used: $f = 1880$ MHz; $\sigma = 1.431$ mho/m; $\epsilon_r = 38.381$; $\rho = 1000$ kg/m³

Ambient Temperature: 22.3 °C Liquid Temperature: 21.5 °C

Phantom section: Left Section

DASY5 Configuration:

Sensor-Surface: 4mm (Mechanical Surface Detection)

Probe: EX3DV4 - SN3753; ConvF(7.63, 7.63, 7.63); Calibrated: 1/17/2013;

Electronics: DAE4 Sn1317; Calibrated: 1/25/2013

Phantom: SAM 2; Type: SAM;

Measurement SW: DASY52, Version 52.8 (2); SEMCAD X Version 14.6.6 (6824)

Left Tilt Middle/Area Scan (7x12x1): Measurement grid: dx=15mm, dy=15mm

Maximum value of SAR (measured) = 0.0742 W/kg

Left Tilt Middle/Zoom Scan (5x5x7)/Cube 0: Measurement grid: dx=8mm, dy=8mm, dz=5mm

Reference Value = 7.510 V/m; Power Drift = 0.025 dB

Peak SAR (extrapolated) = 0.121 mW/g

SAR(1 g) = 0.078 mW/g; SAR(10 g) = 0.050 mW/g

Maximum value of SAR (measured) = 0.0824 W/kg

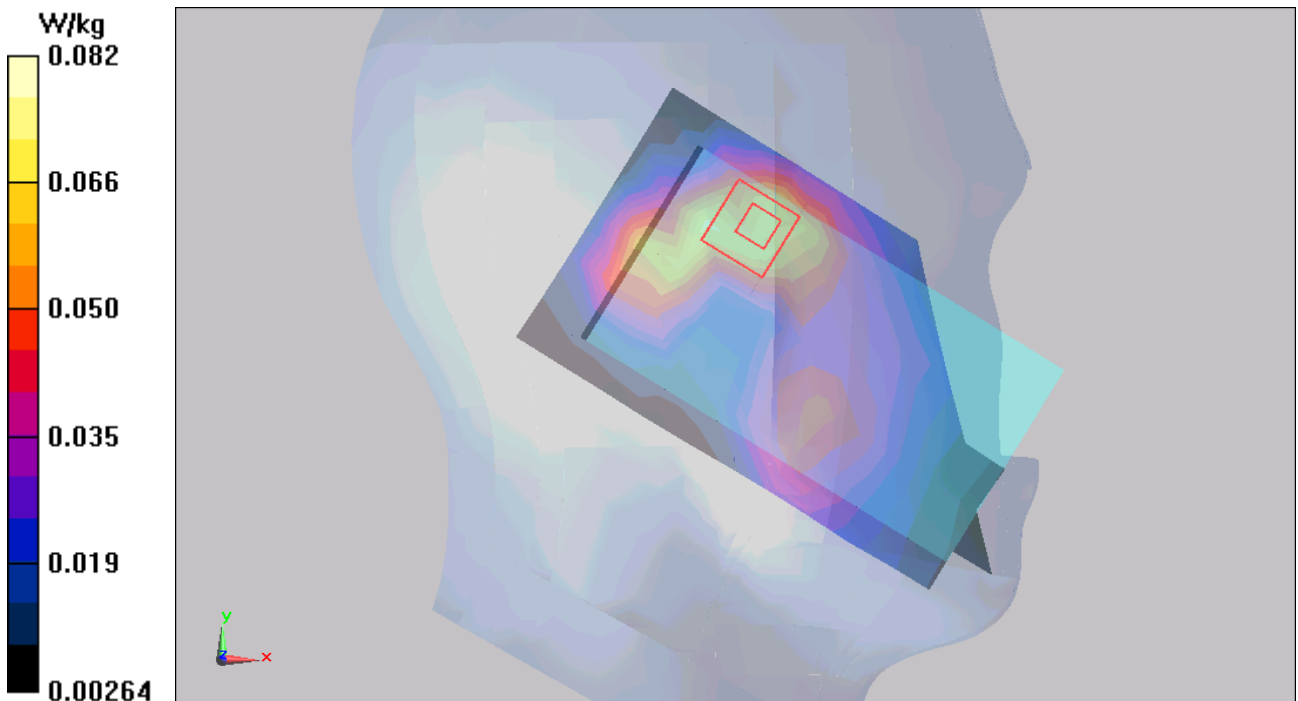

Figure 26 Left Hand Tilt 15° GSM 1900 Channel 661

TA Technology (Shanghai) Co., Ltd. Test Report

Report No.: RXA1307-0093SAR01R3

Page 88 of 225

GSM 1900 Right Cheek Middle

Date/Time: 7/18/2013 6:06:52 AM

Communication System: GSM; Frequency: 1880 MHz; Duty Cycle: 1:8.30042

Medium parameters used: $f = 1880$ MHz; $\sigma = 1.431$ mho/m; $\epsilon_r = 38.381$; $\rho = 1000$ kg/m³

Ambient Temperature: 22.3 °C Liquid Temperature: 21.5 °C

Phantom section: Right Section

DASY5 Configuration:

Sensor-Surface: 4mm (Mechanical Surface Detection)

Probe: EX3DV4 - SN3753; ConvF(7.63, 7.63, 7.63); Calibrated: 1/17/2013;

Electronics: DAE4 Sn1317; Calibrated: 1/25/2013

Phantom: SAM 2; Type: SAM;

Measurement SW: DASY52, Version 52.8 (2); SEMCAD X Version 14.6.6 (6824)

Right Cheek Middle/Area Scan (7x12x1): Measurement grid: dx=15mm, dy=15mm

Maximum value of SAR (measured) = 0.259 W/kg

Right Cheek Middle/Zoom Scan (5x5x7)/Cube 0: Measurement grid: dx=8mm, dy=8mm, dz=5mm

Reference Value = 5.534 V/m; Power Drift = -0.15 dB

Peak SAR (extrapolated) = 0.419 mW/g

SAR(1 g) = 0.277 mW/g; SAR(10 g) = 0.174 mW/g

Maximum value of SAR (measured) = 0.301 W/kg

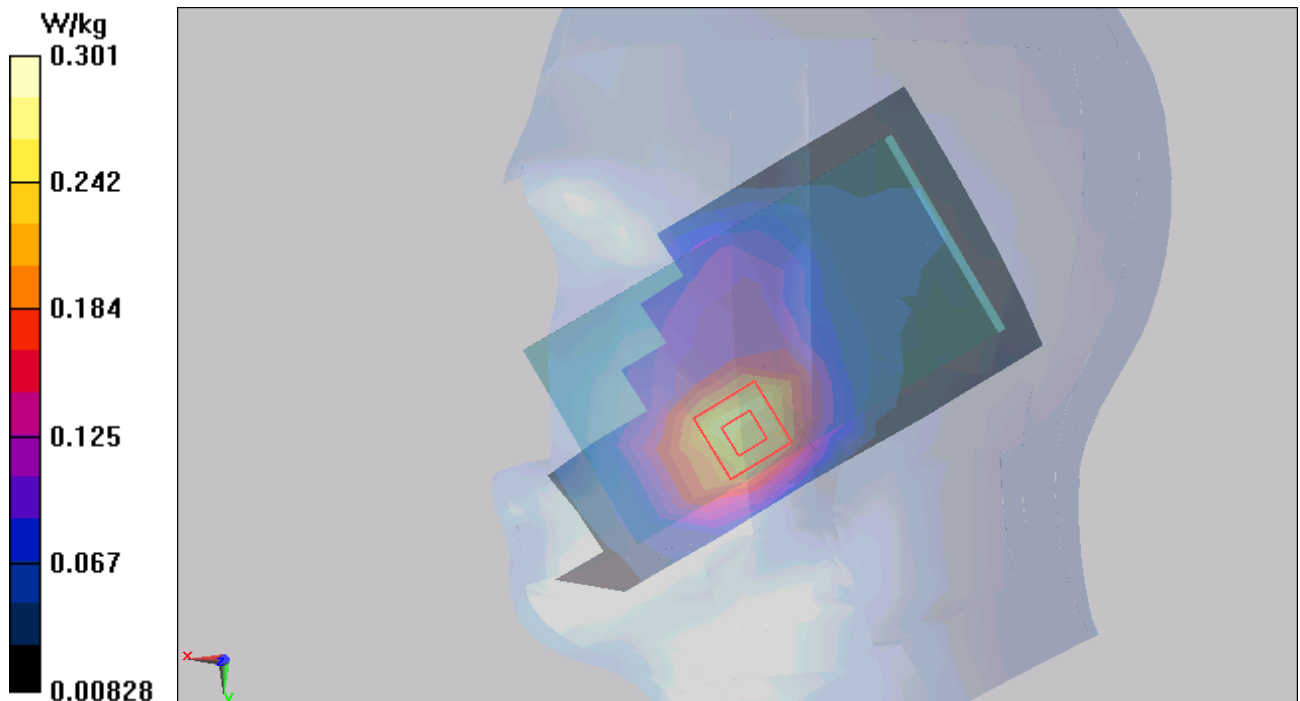

Figure 27 Right Hand Touch Cheek GSM 1900 Channel 661

TA Technology (Shanghai) Co., Ltd.
Test Report

GSM 1900 Right Tilt Middle

Date/Time: 7/18/2013 6:23:14 AM

Communication System: GSM; Frequency: 1880 MHz; Duty Cycle: 1:8.30042

Medium parameters used: $f = 1880$ MHz; $\sigma = 1.431$ mho/m; $\epsilon_r = 38.381$; $\rho = 1000$ kg/m³

Ambient Temperature: 22.3 °C Liquid Temperature: 21.5 °C

Phantom section: Right Section

DASY5 Configuration:

Sensor-Surface: 4mm (Mechanical Surface Detection)

Probe: EX3DV4 - SN3753; ConvF(7.63, 7.63, 7.63); Calibrated: 1/17/2013;

Electronics: DAE4 Sn1317; Calibrated: 1/25/2013

Phantom: SAM 2; Type: SAM;

Measurement SW: DASY52, Version 52.8 (2); SEMCAD X Version 14.6.6 (6824)

Right Tilt Middle/Area Scan (7x12x1): Measurement grid: dx=15mm, dy=15mm

Maximum value of SAR (measured) = 0.0654 W/kg

Right Tilt Middle/Zoom Scan (5x5x7)/Cube 0: Measurement grid: dx=8mm, dy=8mm, dz=5mm

Reference Value = 7.424 V/m; Power Drift = 0.13 dB

Peak SAR (extrapolated) = 0.123 mW/g

SAR(1 g) = 0.073 mW/g; SAR(10 g) = 0.040 mW/g

Maximum value of SAR (measured) = 0.0816 W/kg

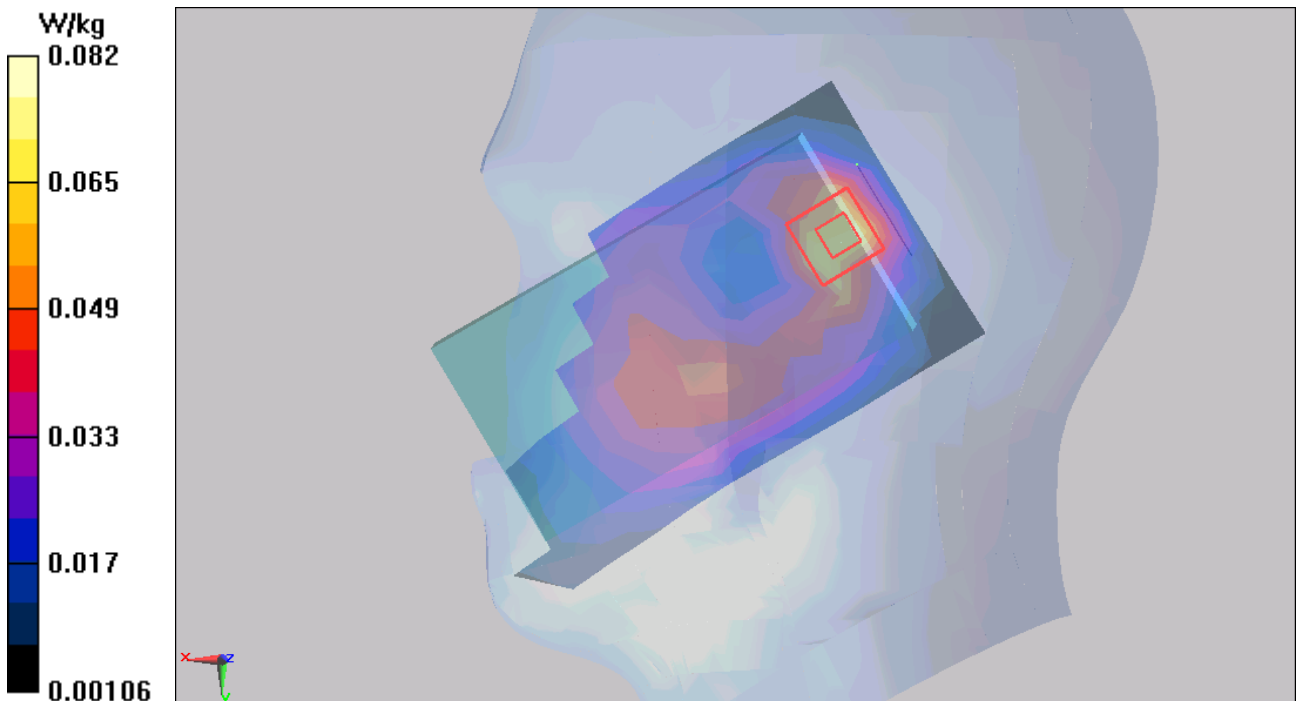

Figure 28 Right Hand Tilt 15° GSM 1900 Channel 661

TA Technology (Shanghai) Co., Ltd.
Test Report

Report No.: RXA1307-0093SAR01R3

Page 90 of 225

GSM 1900 GPRS (2Txslots) Back Side High

Date/Time: 7/18/2013 12:54:21 AM

Communication System: GPRS 2TX; Frequency: 1909.8 MHz; Duty Cycle: 1:4.14954

Medium parameters used: $f = 1910$ MHz; $\sigma = 1.534$ mho/m; $\epsilon_r = 52.525$; $\rho = 1000$ kg/m³

Ambient Temperature: 22.3 °C Liquid Temperature: 21.5 °C

Phantom section: Flat Section

DASY5 Configuration:

Sensor-Surface: 4mm (Mechanical Surface Detection)

Probe: EX3DV4 - SN3753; ConvF(7.33, 7.33, 7.33); Calibrated: 1/17/2013;

Electronics: DAE4 Sn1317; Calibrated: 1/25/2013

Phantom: SAM 2; Type: SAM;

Measurement SW: DASY52, Version 52.8 (2); SEMCAD X Version 14.6.6 (6824)

Back Side High/Area Scan (7x11x1): Measurement grid: dx=15mm, dy=15mm

Maximum value of SAR (measured) = 0.862 W/kg

Back Side High/Zoom Scan (5x5x7)/Cube 1: Measurement grid: dx=8mm, dy=8mm, dz=5mm

Reference Value = 12.204 V/m; Power Drift = -0.00 dB

Peak SAR (extrapolated) = 1.296 mW/g

SAR(1 g) = 0.806 mW/g; SAR(10 g) = 0.488 mW/g

Maximum value of SAR (measured) = 0.891 W/kg

Back Side High/Zoom Scan (5x5x7)/Cube 0: Measurement grid: dx=8mm, dy=8mm, dz=5mm

Reference Value = 12.204 V/m; Power Drift = -0.001 dB

Peak SAR (extrapolated) = 1.292 mW/g

SAR(1 g) = 0.824 mW/g; SAR(10 g) = 0.516 mW/g

Maximum value of SAR (measured) = 0.877 W/kg

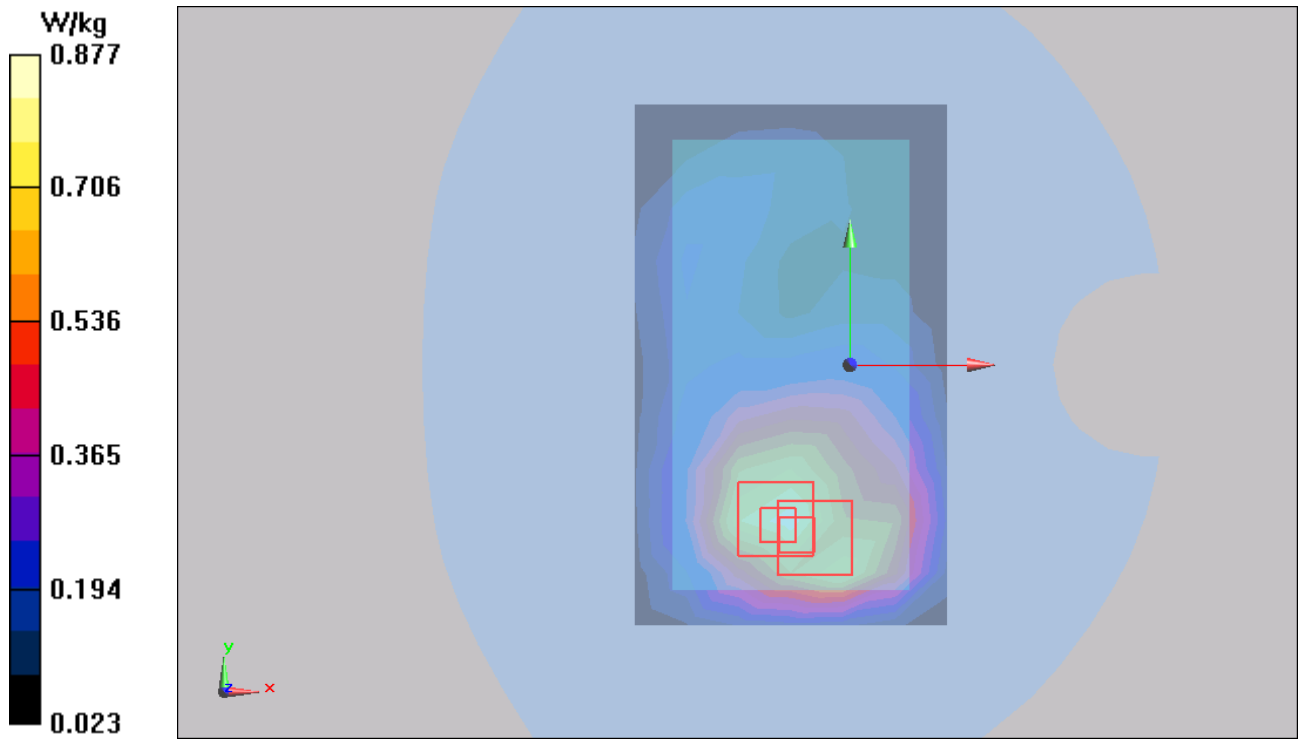

Figure 29 Body, Back Side, GSM 1900 GPRS (2Txslots) Channel 810

GSM 1900 GPRS (2Txslots) Back Side Middle

Date/Time: 7/18/2013 12:36:06 AM

Communication System: GPRS 2TX; Frequency: 1880 MHz; Duty Cycle: 1:4.14954

Medium parameters used: $f = 1880$ MHz; $\sigma = 1.503$ mho/m; $\epsilon_r = 52.61$; $\rho = 1000$ kg/m³

Ambient Temperature: 22.3 °C Liquid Temperature: 21.5 °C

Phantom section: Flat Section

DASY5 Configuration:

Sensor-Surface: 4mm (Mechanical Surface Detection)

Probe: EX3DV4 - SN3753; ConvF(7.33, 7.33, 7.33); Calibrated: 1/17/2013;

Electronics: DAE4 Sn1317; Calibrated: 1/25/2013

Phantom: SAM 2; Type: SAM;

Measurement SW: DASY52, Version 52.8 (2); SEMCAD X Version 14.6.6 (6824)

Back Side Middle/Area Scan (7x11x1): Measurement grid: dx=15mm, dy=15mm

Maximum value of SAR (measured) = 0.887 W/kg

Back Side Middle/Zoom Scan (5x5x7)/Cube 0: Measurement grid: dx=8mm, dy=8mm, dz=5mm

Reference Value = 11.412 V/m; Power Drift = -0.05 dB

Peak SAR (extrapolated) = 1.312 mW/g

SAR(1 g) = 0.832 mW/g; SAR(10 g) = 0.510 mW/g

Maximum value of SAR (measured) = 0.913 W/kg

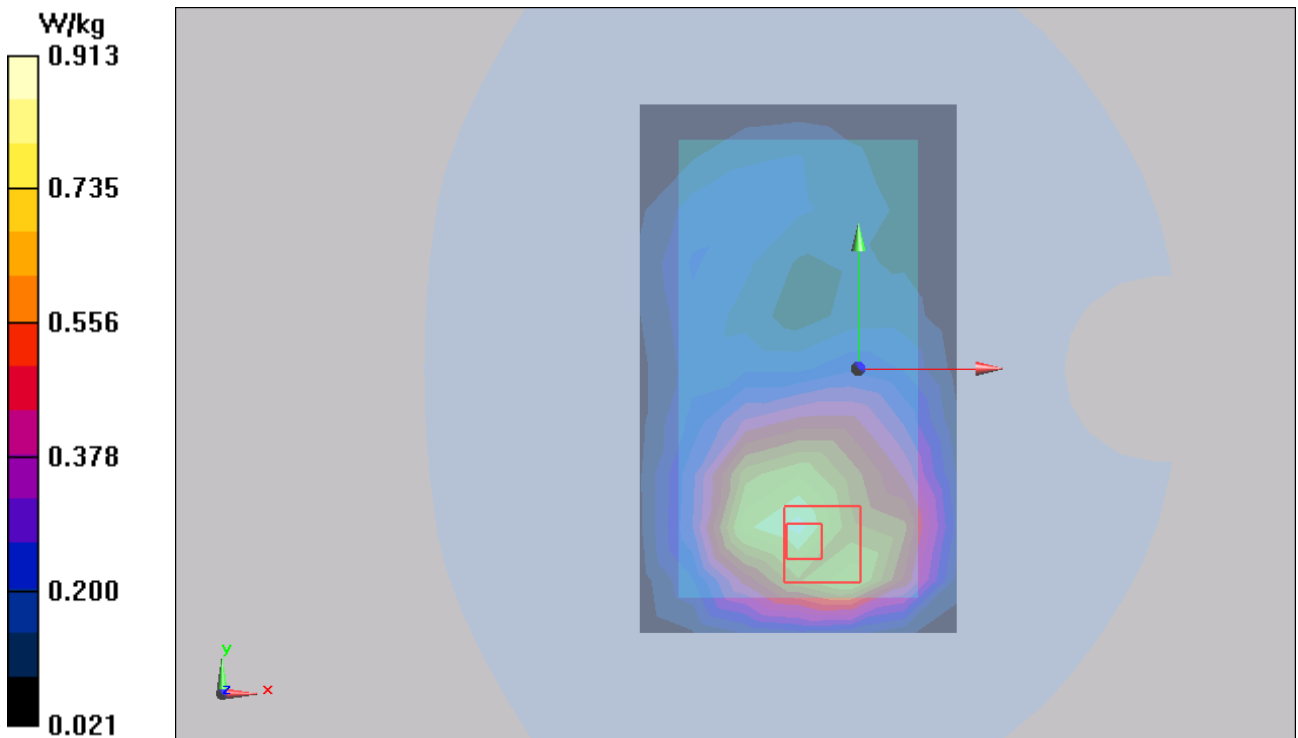

Figure 30 Body, Back Side, GSM 1900 GPRS (2Txslots) Channel 661

TA Technology (Shanghai) Co., Ltd. Test Report

Report No.: RXA1307-0093SAR01R3

Page 93 of 225

GSM 1900 GPRS (2Txslots) Back Side Low

Date/Time: 7/18/2013 1:18:19 AM

Communication System: GPRS 2TX; Frequency: 1850.2 MHz; Duty Cycle: 1:4.14954

Medium parameters used (interpolated): $f = 1850.2$ MHz; $\sigma = 1.472$ mho/m; $\epsilon_r = 52.664$; $\rho = 1000$ kg/m³

Ambient Temperature: 22.3 °C Liquid Temperature: 21.5 °C

Phantom section: Flat Section

DASY5 Configuration:

Sensor-Surface: 4mm (Mechanical Surface Detection)

Probe: EX3DV4 - SN3753; ConvF(7.33, 7.33, 7.33); Calibrated: 1/17/2013;

Electronics: DAE4 Sn1317; Calibrated: 1/25/2013

Phantom: SAM 2; Type: SAM;

Measurement SW: DASY52, Version 52.8 (2); SEMCAD X Version 14.6.6 (6824)

Back Side Low/Area Scan (7x11x1): Measurement grid: dx=15mm, dy=15mm

Maximum value of SAR (measured) = 0.930 W/kg

Back Side Low/Zoom Scan (5x5x7)/Cube 0: Measurement grid: dx=8mm, dy=8mm, dz=5mm

Reference Value = 10.379 V/m; Power Drift = -0.05 dB

Peak SAR (extrapolated) = 1.333 mW/g

SAR(1 g) = 0.868 mW/g; SAR(10 g) = 0.550 mW/g

Maximum value of SAR (measured) = 0.923 W/kg

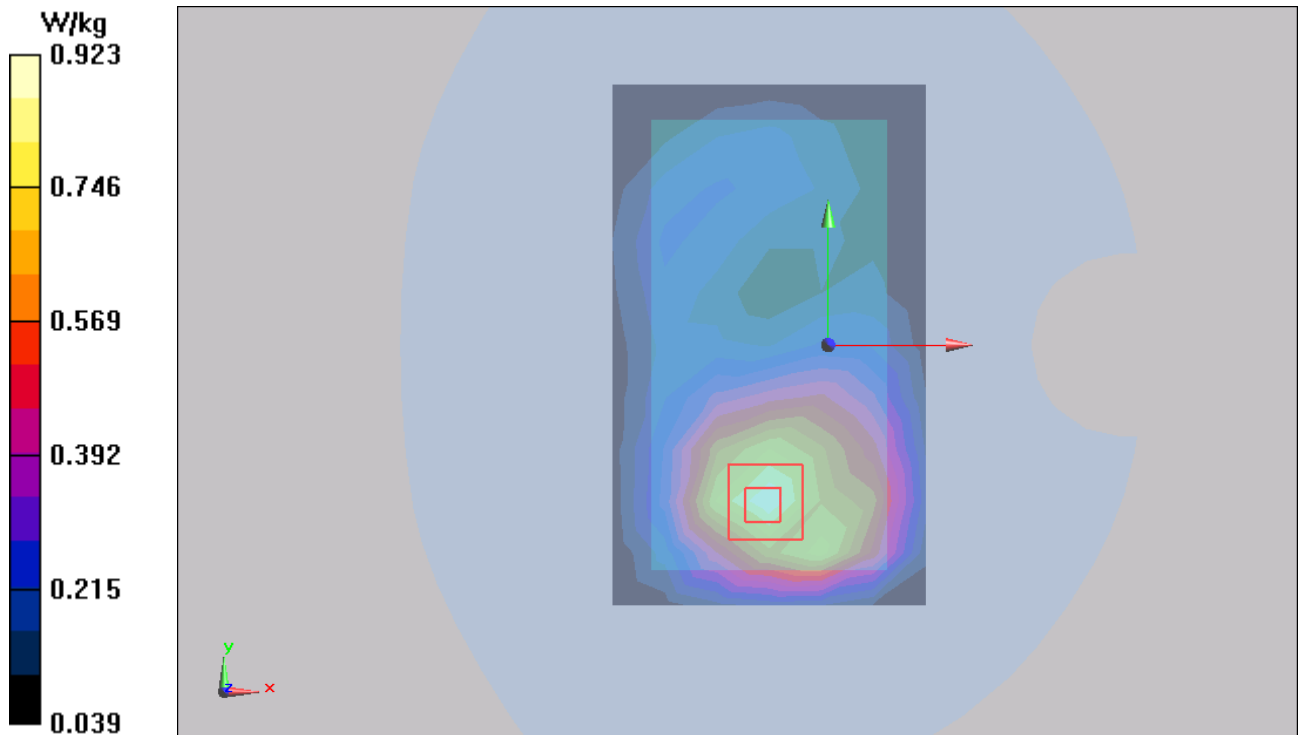

TA Technology (Shanghai) Co., Ltd.
Test Report

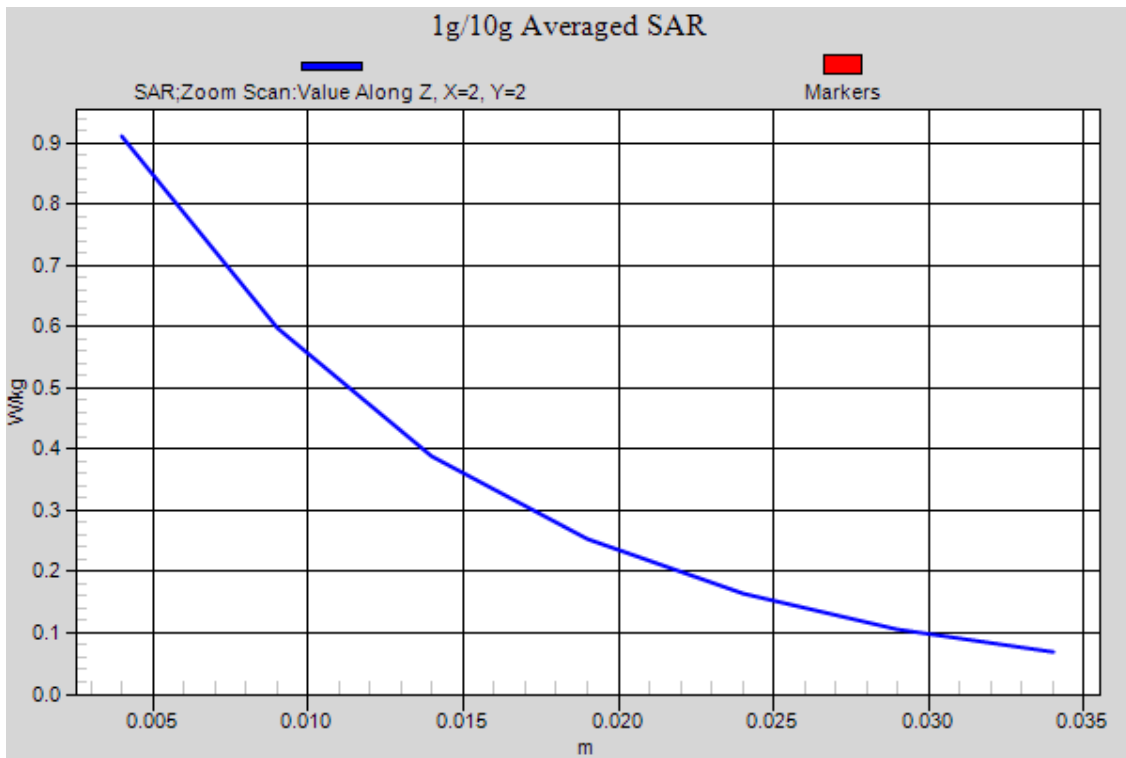

Figure 31 Body, Back Side, GSM 1900 GPRS (2Txslots) Channel 512

GSM 1900 GPRS (2Txslots) Front Side Middle

Date/Time: 7/18/2013 1:36:52 AM

Communication System: GPRS 2TX; Frequency: 1880 MHz; Duty Cycle: 1:4.14954

Medium parameters used: $f = 1880$ MHz; $\sigma = 1.503$ mho/m; $\epsilon_r = 52.61$; $\rho = 1000$ kg/m³

Ambient Temperature: 22.3 °C Liquid Temperature: 21.5 °C

Phantom section: Flat Section

DASY5 Configuration:

Sensor-Surface: 4mm (Mechanical Surface Detection)

Probe: EX3DV4 - SN3753; ConvF(7.33, 7.33, 7.33); Calibrated: 1/17/2013;

Electronics: DAE4 Sn1317; Calibrated: 1/25/2013

Phantom: SAM 2; Type: SAM;

Measurement SW: DASY52, Version 52.8 (2); SEMCAD X Version 14.6.6 (6824)

Front Side Middle/Area Scan (7x11x1): Measurement grid: dx=15mm, dy=15mm

Maximum value of SAR (measured) = 0.540 W/kg

Front Side Middle/Zoom Scan (5x5x7)/Cube 0: Measurement grid: dx=8mm, dy=8mm, dz=5mm

Reference Value = 9.865 V/m; Power Drift = -0.03 dB

Peak SAR (extrapolated) = 0.837 mW/g

SAR(1 g) = 0.539 mW/g; SAR(10 g) = 0.334 mW/g

Maximum value of SAR (measured) = 0.584 W/kg

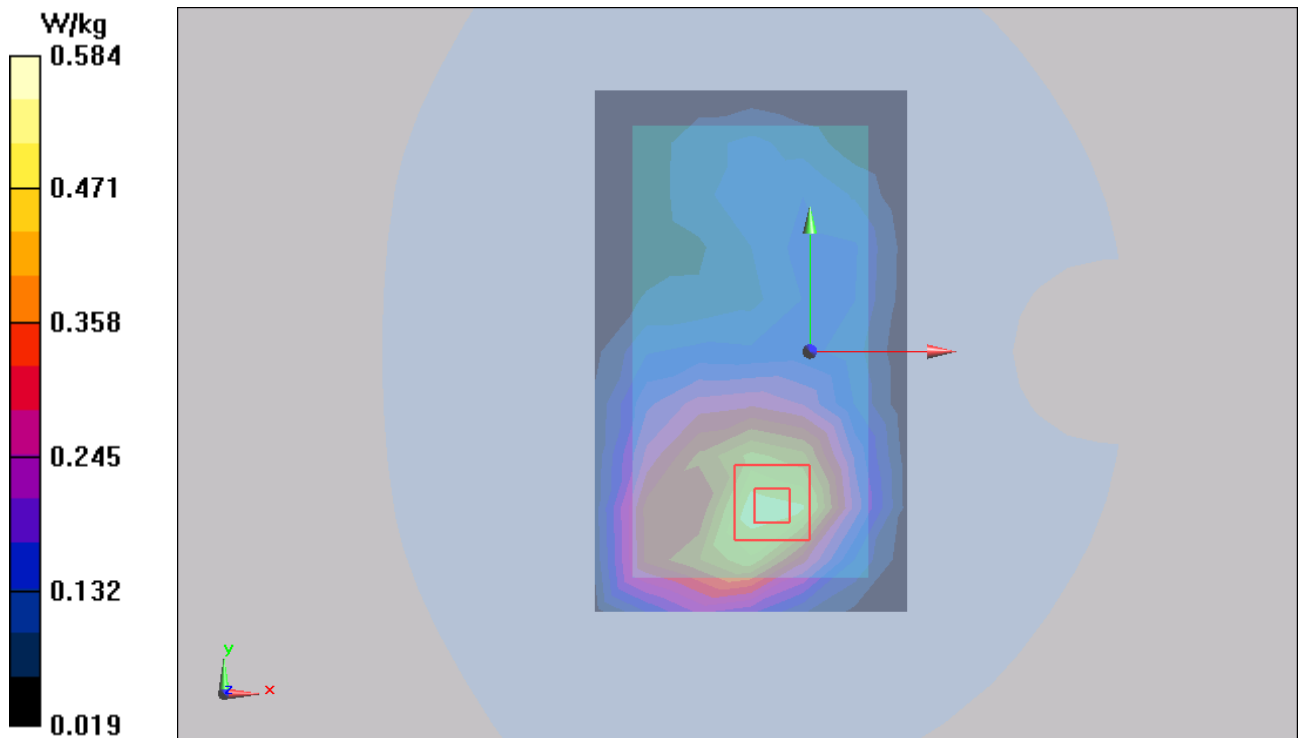

Figure 32 Body, Front Side, GSM 1900 GPRS (2Txslots) Channel 661

GSM 1900 GPRS (2Txslots) Left Edge Middle

Date/Time: 7/18/2013 2:00:47 AM

Communication System: GPRS 2TX; Frequency: 1880 MHz; Duty Cycle: 1:4.14954

Medium parameters used: $f = 1880$ MHz; $\sigma = 1.503$ mho/m; $\epsilon_r = 52.61$; $\rho = 1000$ kg/m³

Ambient Temperature: 22.3 °C Liquid Temperature: 21.5 °C

Phantom section: Flat Section

DASY5 Configuration:

Sensor-Surface: 4mm (Mechanical Surface Detection)

Probe: EX3DV4 - SN3753; ConvF(7.33, 7.33, 7.33); Calibrated: 1/17/2013;

Electronics: DAE4 Sn1317; Calibrated: 1/25/2013

Phantom: SAM 2; Type: SAM;

Measurement SW: DASY52, Version 52.8 (2); SEMCAD X Version 14.6.6 (6824)

Left Side Middle/Area Scan (4x12x1): Measurement grid: dx=15mm, dy=15mm

Maximum value of SAR (measured) = 0.292 W/kg

Left Side Middle/Zoom Scan (5x5x7)/Cube 0: Measurement grid: dx=8mm, dy=8mm, dz=5mm

Reference Value = 7.337 V/m; Power Drift = 0.16 dB

Peak SAR (extrapolated) = 0.469 mW/g

SAR(1 g) = 0.280 mW/g; SAR(10 g) = 0.156 mW/g

Maximum value of SAR (measured) = 0.311 W/kg

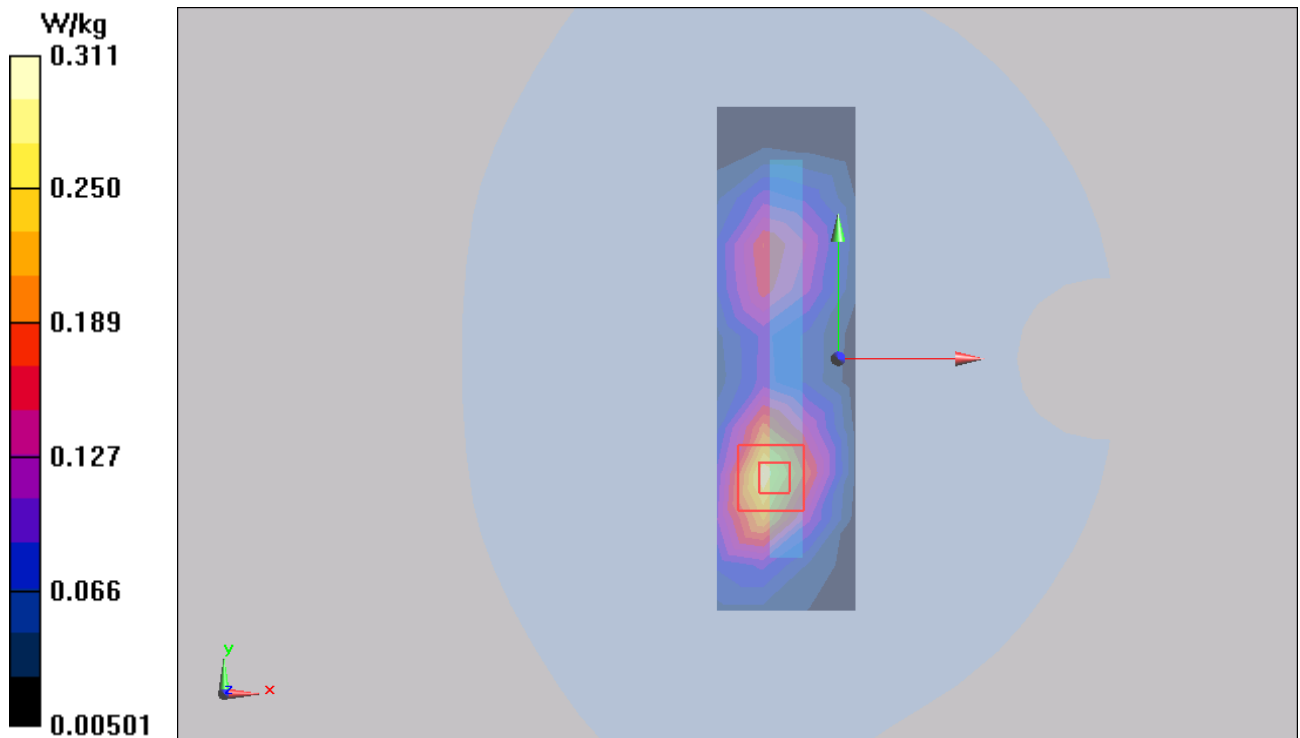

Figure 33 Body, Left Edge, GSM 1900 GPRS (2Txslots) Channel 661

GSM 1900 GPRS (2Txslots) Right Edge Middle

Date/Time: 7/18/2013 2:41:03 AM

Communication System: GPRS 2TX; Frequency: 1880 MHz; Duty Cycle: 1:4.14954

Medium parameters used: $f = 1880$ MHz; $\sigma = 1.503$ mho/m; $\epsilon_r = 52.61$; $\rho = 1000$ kg/m³

Ambient Temperature: 22.3 °C Liquid Temperature: 21.5 °C

Phantom section: Flat Section

DASY5 Configuration:

Sensor-Surface: 4mm (Mechanical Surface Detection)

Probe: EX3DV4 - SN3753; ConvF(7.33, 7.33, 7.33); Calibrated: 1/17/2013;

Electronics: DAE4 Sn1317; Calibrated: 1/25/2013

Phantom: SAM 2; Type: SAM;

Measurement SW: DASY52, Version 52.8 (2); SEMCAD X Version 14.6.6 (6824)

Right Side Middle/Area Scan (4x12x1): Measurement grid: dx=15mm, dy=15mm

Maximum value of SAR (measured) = 0.185 W/kg

Right Side Middle/Zoom Scan (5x5x7)/Cube 0: Measurement grid: dx=8mm, dy=8mm, dz=5mm

Reference Value = 7.813 V/m; Power Drift = 0.06 dB

Peak SAR (extrapolated) = 0.280 mW/g

SAR(1 g) = 0.174 mW/g; SAR(10 g) = 0.104 mW/g

Maximum value of SAR (measured) = 0.188 W/kg

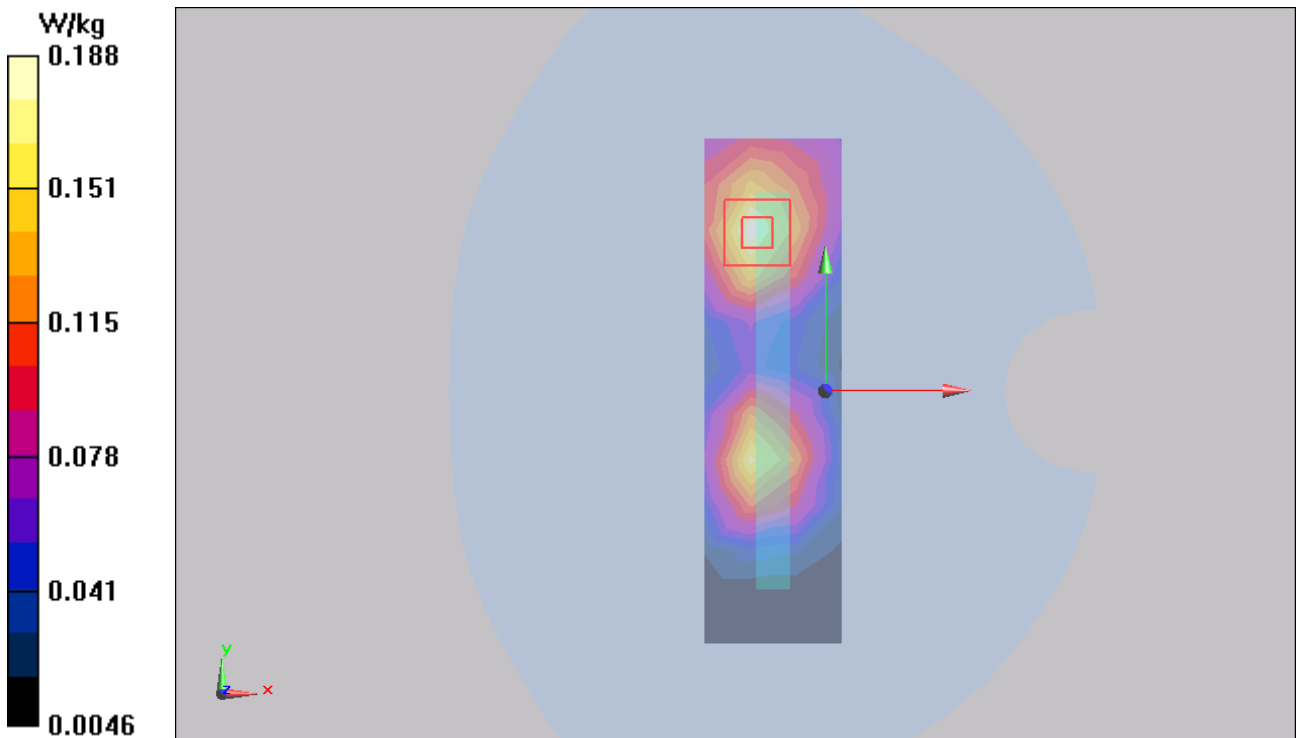

Figure 34 Body, Right Edge, GSM 1900 GPRS (2Txslots) Channel 661

GSM 1900 GPRS (2Txslots) Bottom Edge Middle

Date/Time: 7/18/2013 3:03:09 AM

Communication System: GPRS 2TX; Frequency: 1880 MHz; Duty Cycle: 1:4.14954

Medium parameters used: $f = 1880$ MHz; $\sigma = 1.503$ mho/m; $\epsilon_r = 52.61$; $\rho = 1000$ kg/m³

Ambient Temperature: 22.3 °C Liquid Temperature: 21.5 °C

Phantom section: Flat Section

DASY5 Configuration:

Sensor-Surface: 4mm (Mechanical Surface Detection)

Probe: EX3DV4 - SN3753; ConvF(7.33, 7.33, 7.33); Calibrated: 1/17/2013;

Electronics: DAE4 Sn1317; Calibrated: 1/25/2013

Phantom: SAM 2; Type: SAM;

Measurement SW: DASY52, Version 52.8 (2); SEMCAD X Version 14.6.6 (6824)

Bottom Side Middle/Area Scan (4x8x1): Measurement grid: dx=15mm, dy=15mm

Maximum value of SAR (measured) = 0.648 W/kg

Bottom Side Middle/Zoom Scan (5x5x7)/Cube 0: Measurement grid: dx=8mm, dy=8mm, dz=5mm

Reference Value = 21.266 V/m; Power Drift = 0.02 dB

Peak SAR (extrapolated) = 1.036 mW/g

SAR(1 g) = 0.622 mW/g; SAR(10 g) = 0.364 mW/g

Maximum value of SAR (measured) = 0.680 W/kg

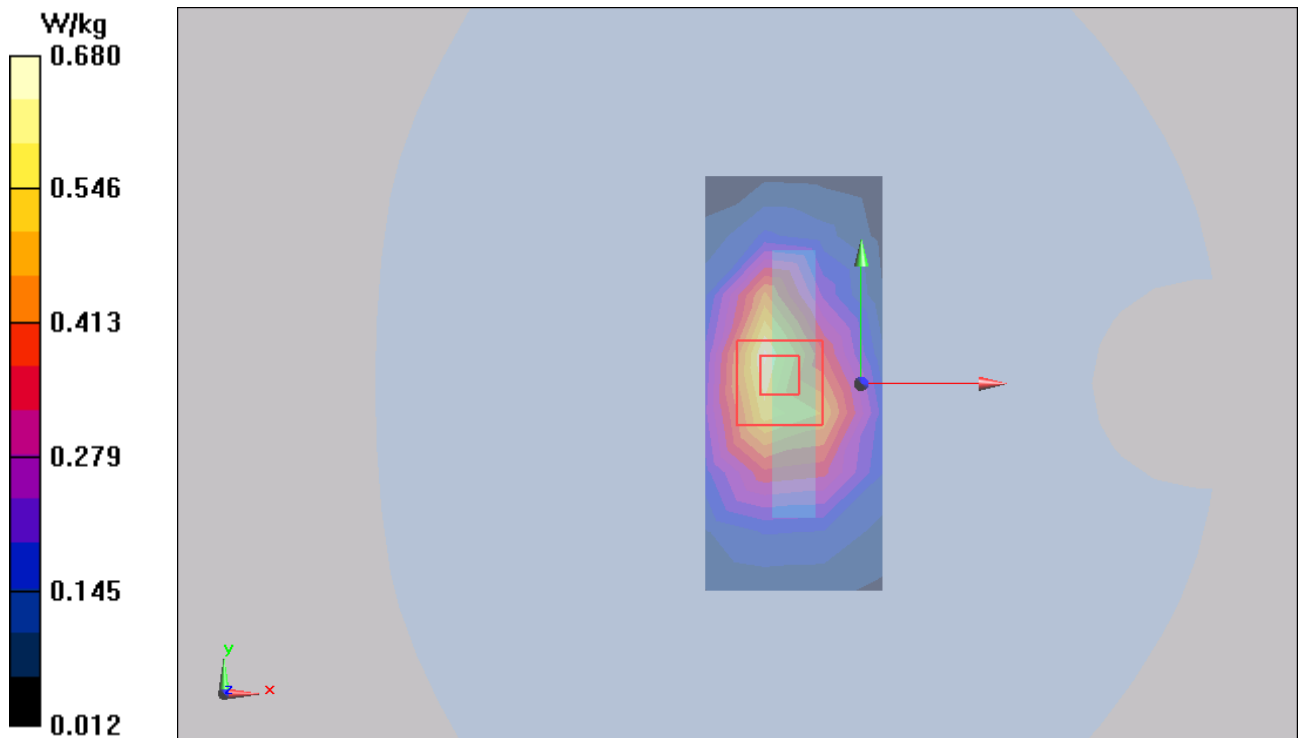

Figure 35 Body, Bottom Edge, GSM 1900 GPRS (2Txslots) Channel 661

TA Technology (Shanghai) Co., Ltd. Test Report

Report No.: RXA1307-0093SAR01R3

Page 99 of 225

GSM 1900 GPRS (2Txslots) Back Side Low (1st Repeated)

Date/Time: 7/18/2013 4:36:06PM

Communication System: GPRS 2TX; Frequency: 1850.2 MHz; Duty Cycle: 1:4.14954

Medium parameters used (interpolated): $f = 1850.2$ MHz; $\sigma = 1.472$ mho/m; $\epsilon_r = 52.664$; $\rho = 1000$ kg/m³

Ambient Temperature: 22.3 °C Liquid Temperature: 21.5 °C

Phantom section: Flat Section

DASY5 Configuration:

Sensor-Surface: 4mm (Mechanical Surface Detection)

Probe: EX3DV4 - SN3753; ConvF(7.33, 7.33, 7.33); Calibrated: 1/17/2013;

Electronics: DAE4 Sn1317; Calibrated: 1/25/2013

Phantom: SAM 2; Type: SAM;

Measurement SW: DASY52, Version 52.8 (2); SEMCAD X Version 14.6.6 (6824)

Back Side Low/Area Scan (61x101x1): Interpolated grid: dx=15 mm, dy=15 mm

Maximum value of SAR (interpolated) = 0.882 W/kg

Back Side Low/Zoom Scan (5x5x7)/Cube 0: Measurement grid: dx=8mm, dy=8mm, dz=5mm

Reference Value = 11.356 V/m; Power Drift = -0.05 dB

Peak SAR (extrapolated) = 1.272 mW/g

SAR(1 g) = 0.808 mW/g; SAR(10 g) = 0.495 mW/g

Maximum value of SAR (measured) = 0.886 W/kg

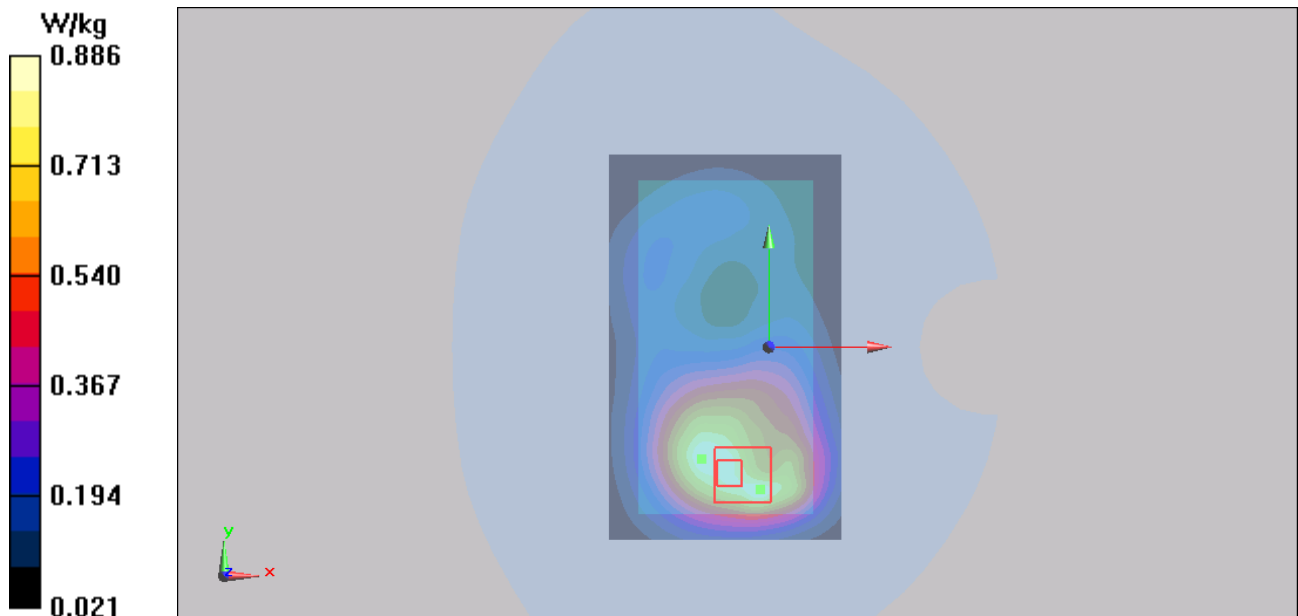

Figure 36 Body, Back Side, GSM 1900 GPRS (2Txslots) Channel 512

TA Technology (Shanghai) Co., Ltd. Test Report

Report No.: RXA1307-0093SAR01R3

Page 100 of 225

UMTS Band II Left Cheek Middle

Date/Time: 7/18/2013 9:40:40 AM

Communication System: WCDMA; Frequency: 1880 MHz; Duty Cycle: 1:1

Medium parameters used: $f = 1880$ MHz; $\sigma = 1.431$ mho/m; $\epsilon_r = 38.381$; $\rho = 1000$ kg/m³

Ambient Temperature: 22.3 °C Liquid Temperature: 21.5 °C

Phantom section: Left Section

DASY5 Configuration:

Sensor-Surface: 4mm (Mechanical Surface Detection)

Probe: EX3DV4 - SN3753; ConvF(7.63, 7.63, 7.63); Calibrated: 1/17/2013;

Electronics: DAE4 Sn1317; Calibrated: 1/25/2013

Phantom: SAM 2; Type: SAM;

Measurement SW: DASY52, Version 52.8 (2); SEMCAD X Version 14.6.6 (6824)

Left Cheek Middle /Area Scan (61x111x1): Interpolated grid: dx=15 mm, dy=15 mm

Maximum value of SAR (interpolated) = 0.588 W/kg

Left Cheek Middle /Zoom Scan (5x5x7)/Cube 0: Measurement grid: dx=8mm, dy=8mm, dz=5mm

Reference Value = 7.917 V/m; Power Drift = 0.13 dB

Peak SAR (extrapolated) = 0.849 mW/g

SAR(1 g) = 0.540 mW/g; SAR(10 g) = 0.336 mW/g

Maximum value of SAR (measured) = 0.586 W/kg

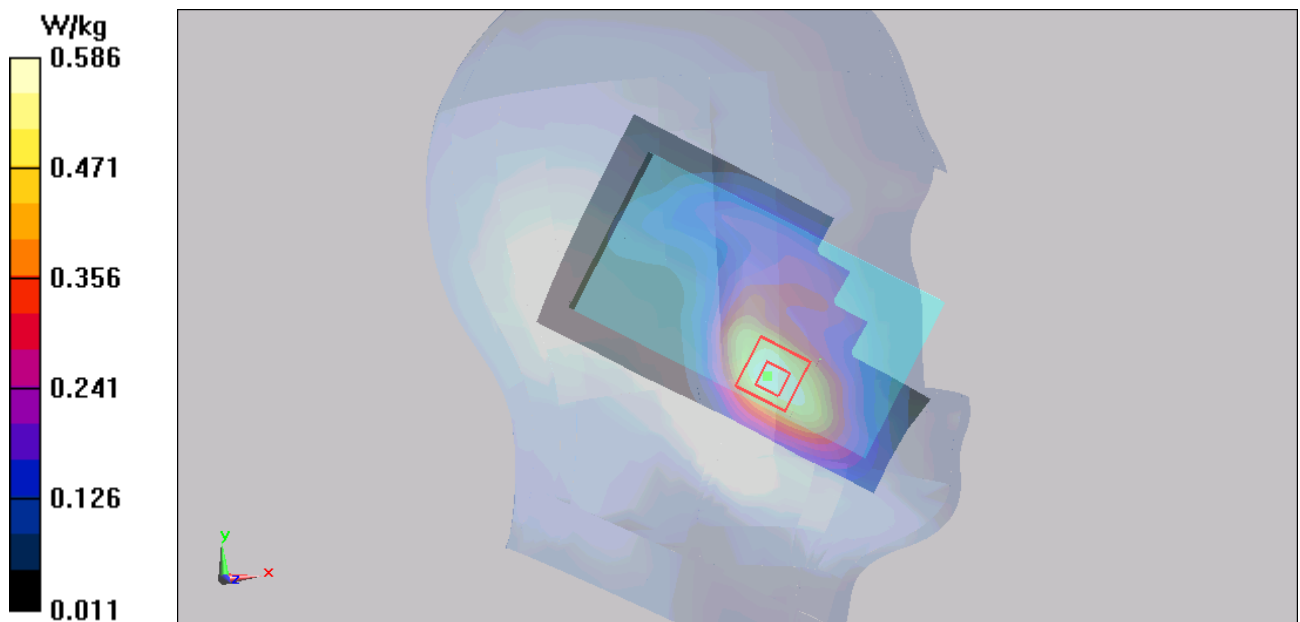

Figure 37 Left Hand Touch Cheek UMTS Band II Channel 9400

UMTS Band II Left Tilt Middle

Date/Time: 7/18/2013 9:57:34 AM

Communication System: WCDMA; Frequency: 1880 MHz; Duty Cycle: 1:1

Medium parameters used: $f = 1880$ MHz; $\sigma = 1.431$ mho/m; $\epsilon_r = 38.381$; $\rho = 1000$ kg/m³

Ambient Temperature: 22.3 °C Liquid Temperature: 21.5 °C

Phantom section: Left Section

DASY5 Configuration:

Sensor-Surface: 4mm (Mechanical Surface Detection)

Probe: EX3DV4 - SN3753; ConvF(7.63, 7.63, 7.63); Calibrated: 1/17/2013;

Electronics: DAE4 Sn1317; Calibrated: 1/25/2013

Phantom: SAM 2; Type: SAM;

Measurement SW: DASY52, Version 52.8 (2); SEMCAD X Version 14.6.6 (6824)

Left Tilt Middle /Area Scan (61x111x1): Interpolated grid: dx=15 mm, dy=15 mm

Maximum value of SAR (interpolated) = 0.171 W/kg

Left Tilt Middle /Zoom Scan (5x5x7)/Cube 0: Measurement grid: dx=8mm, dy=8mm, dz=5mm

Reference Value = 10.148 V/m; Power Drift = 0.18 dB

Peak SAR (extrapolated) = 0.238 mW/g

SAR(1 g) = 0.147 mW/g; SAR(10 g) = 0.093 mW/g

Maximum value of SAR (measured) = 0.155 W/kg

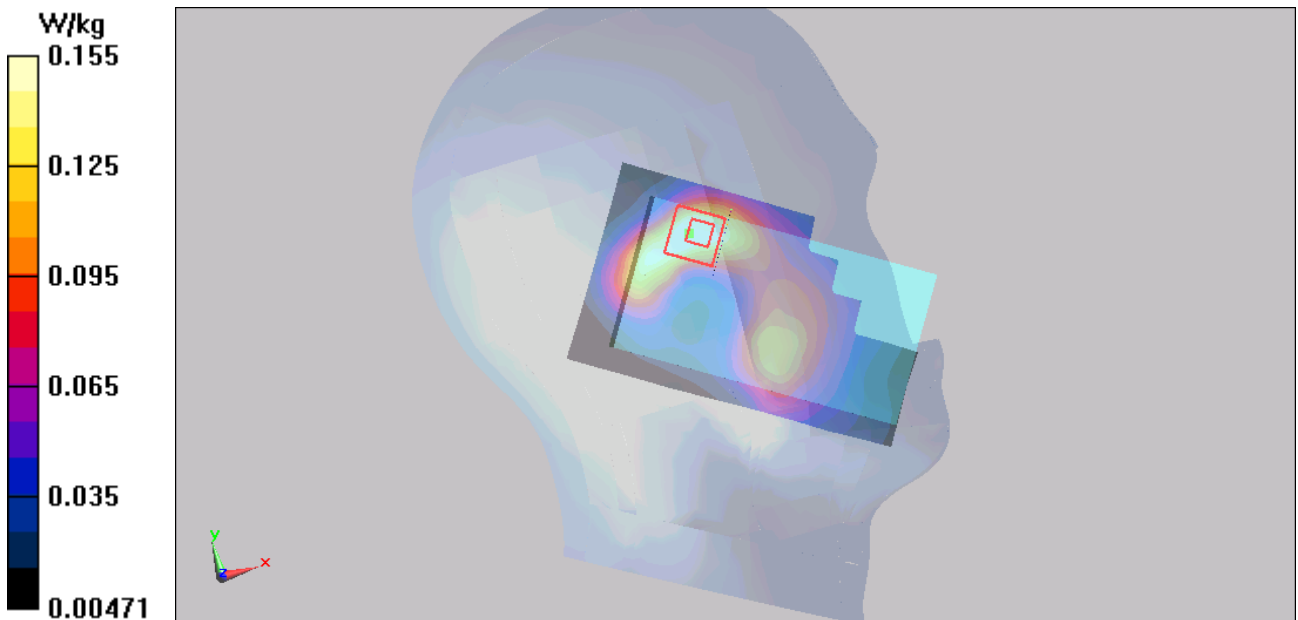

Figure 38 Left Hand Tilt 15° UMTS Band II Channel 9400

TA Technology (Shanghai) Co., Ltd. Test Report

Report No.: RXA1307-0093SAR01R3

Page 102 of 225

UMTS Band II Right Cheek Middle

Date/Time: 7/18/2013 6:59:34 AM

Communication System: WCDMA; Frequency: 1880 MHz; Duty Cycle: 1:1

Medium parameters used: $f = 1880$ MHz; $\sigma = 1.431$ mho/m; $\epsilon_r = 38.381$; $\rho = 1000$ kg/m³

Ambient Temperature: 22.3 °C Liquid Temperature: 21.5 °C

Phantom section: Right Section

DASY5 Configuration:

Sensor-Surface: 4mm (Mechanical Surface Detection)

Probe: EX3DV4 - SN3753; ConvF(7.63, 7.63, 7.63); Calibrated: 1/17/2013;

Electronics: DAE4 Sn1317; Calibrated: 1/25/2013

Phantom: SAM 2; Type: SAM;

Measurement SW: DASY52, Version 52.8 (2); SEMCAD X Version 14.6.6 (6824)

Right Cheek Middle /Area Scan (7x12x1): Measurement grid: dx=15mm, dy=15mm

Maximum value of SAR (measured) = 0.489 W/kg

Right Cheek Middle /Zoom Scan (5x5x7)/Cube 0: Measurement grid: dx=8mm, dy=8mm, dz=5mm

Reference Value = 7.572 V/m; Power Drift = 0.09 dB

Peak SAR (extrapolated) = 0.812 mW/g

SAR(1 g) = 0.543 mW/g; SAR(10 g) = 0.342 mW/g

Maximum value of SAR (measured) = 0.593 W/kg

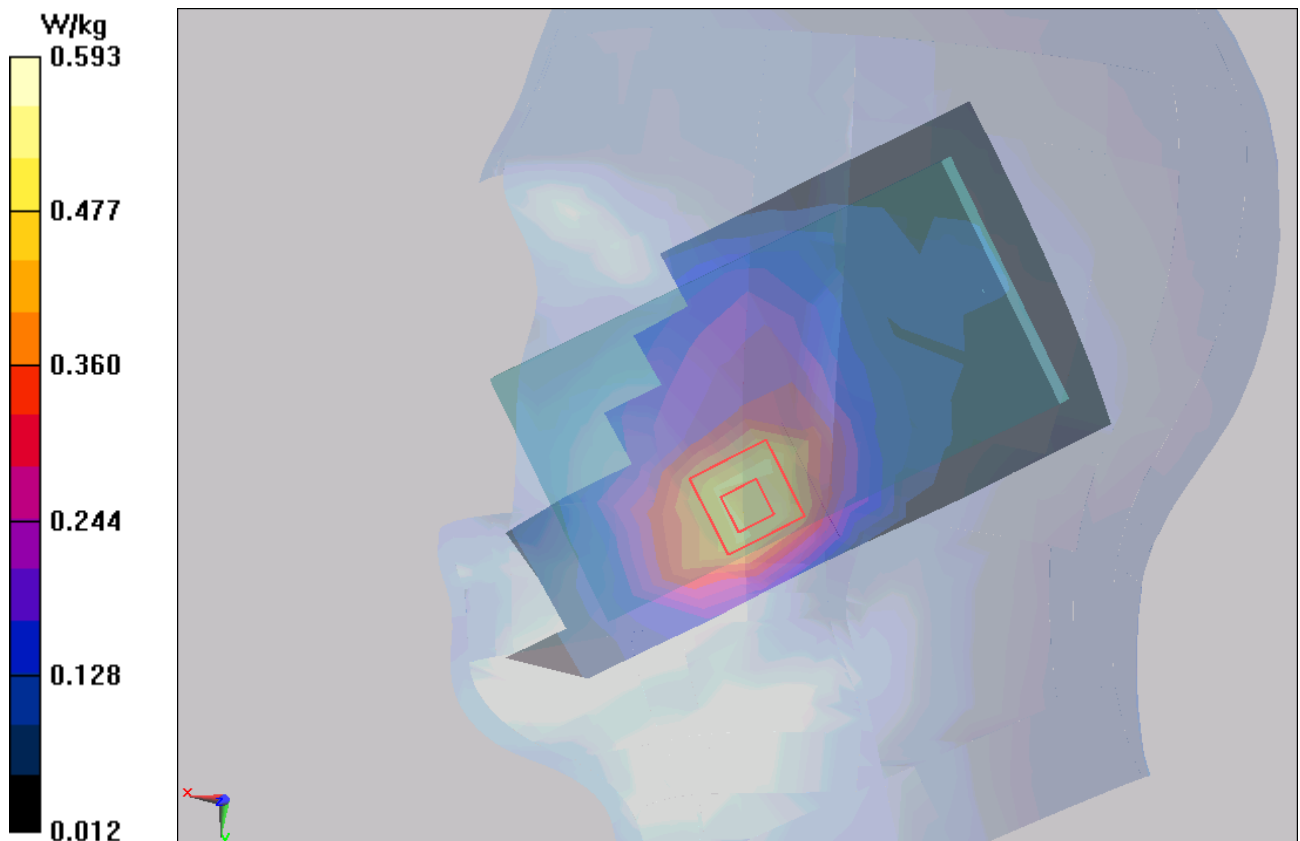

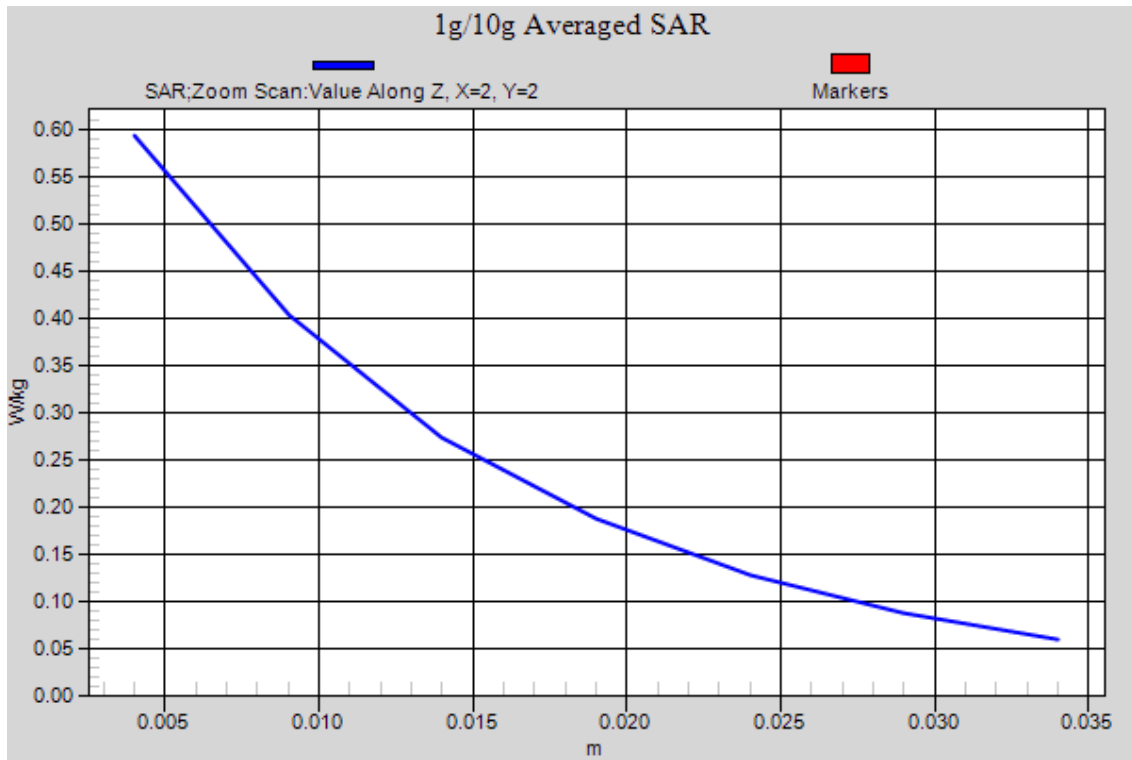

Figure 39 Right Hand Touch Cheek UMTS Band II Channel 9400

TA Technology (Shanghai) Co., Ltd. Test Report

Report No.: RXA1307-0093SAR01R3

Page 104 of 225

UMTS Band II Right Tilt Middle

Date/Time: 7/18/2013 7:15:52 AM

Communication System: WCDMA; Frequency: 1880 MHz; Duty Cycle: 1:1

Medium parameters used: $f = 1880$ MHz; $\sigma = 1.431$ mho/m; $\epsilon_r = 38.381$; $\rho = 1000$ kg/m³

Ambient Temperature: 22.3 °C Liquid Temperature: 21.5 °C

Phantom section: Right Section

DASY5 Configuration:

Sensor-Surface: 4mm (Mechanical Surface Detection)

Probe: EX3DV4 - SN3753; ConvF(7.63, 7.63, 7.63); Calibrated: 1/17/2013;

Electronics: DAE4 Sn1317; Calibrated: 1/25/2013

Phantom: SAM 2; Type: SAM;

Measurement SW: DASY52, Version 52.8 (2); SEMCAD X Version 14.6.6 (6824)

Right Tilt Middle /Area Scan (7x12x1): Measurement grid: dx=15mm, dy=15mm

Maximum value of SAR (measured) = 0.118 W/kg

Right Tilt Middle /Zoom Scan (5x5x7)/Cube 0: Measurement grid: dx=8mm, dy=8mm, dz=5mm

Reference Value = 10.074 V/m; Power Drift = 0.04 dB

Peak SAR (extrapolated) = 0.224 mW/g

SAR(1 g) = 0.135 mW/g; SAR(10 g) = 0.075 mW/g

Maximum value of SAR (measured) = 0.151 W/kg

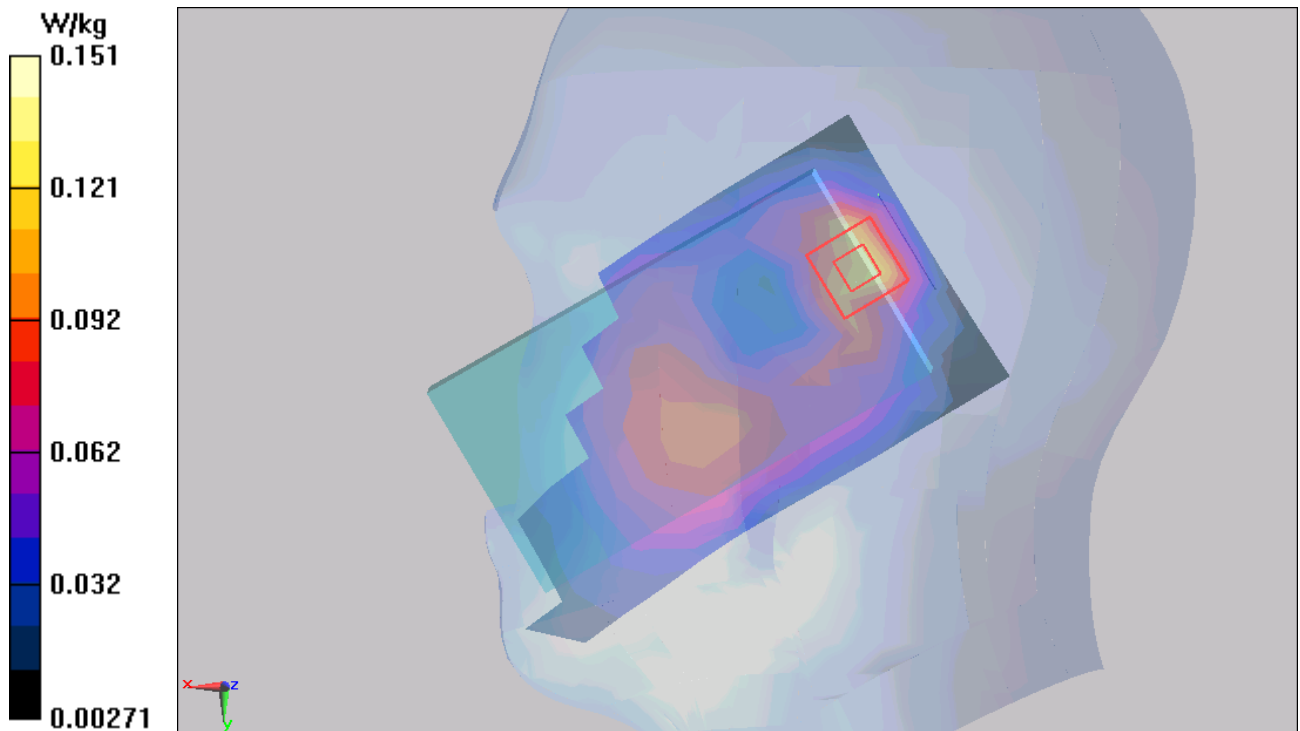

Figure 40 Right Hand Tilt 15° UMTS Band II Channel 9400

TA Technology (Shanghai) Co., Ltd.

Test Report

Report No.: RXA1307-0093SAR01R3

Page 105 of 225

UMTS Band II Back Side High (Hotspot Closed,15mm)

Date/Time: 7/18/2013 2:20:22 PM

Communication System: WCDMA; Frequency: 1907.6 MHz; Duty Cycle: 1:1

Medium parameters used: $f = 1908$ MHz; $\sigma = 1.532$ mho/m; $\epsilon_r = 52.533$; $\rho = 1000$ kg/m³

Ambient Temperature: 22.3 °C Liquid Temperature: 21.5 °C

Phantom section: Flat Section

DASY5 Configuration:

Sensor-Surface: 4mm (Mechanical Surface Detection)

Probe: EX3DV4 - SN3753; ConvF(7.33, 7.33, 7.33); Calibrated: 1/17/2013;

Electronics: DAE4 Sn1317; Calibrated: 1/25/2013

Phantom: SAM 2; Type: SAM;

Measurement SW: DASY52, Version 52.8 (2); SEMCAD X Version 14.6.6 (6824)

Back Side High /Area Scan (61x101x1): Interpolated grid: dx=15 mm, dy=15 mm

Maximum value of SAR (interpolated) = 0.633 W/kg

Back Side High /Zoom Scan (5x5x7)/Cube 0: Measurement grid: dx=8mm, dy=8mm, dz=5mm

Reference Value = 11.905 V/m; Power Drift = -0.09 dB

Peak SAR (extrapolated) = 0.880 mW/g

SAR(1 g) = 0.576 mW/g; SAR(10 g) = 0.371 mW/g

Maximum value of SAR (measured) = 0.613 W/kg

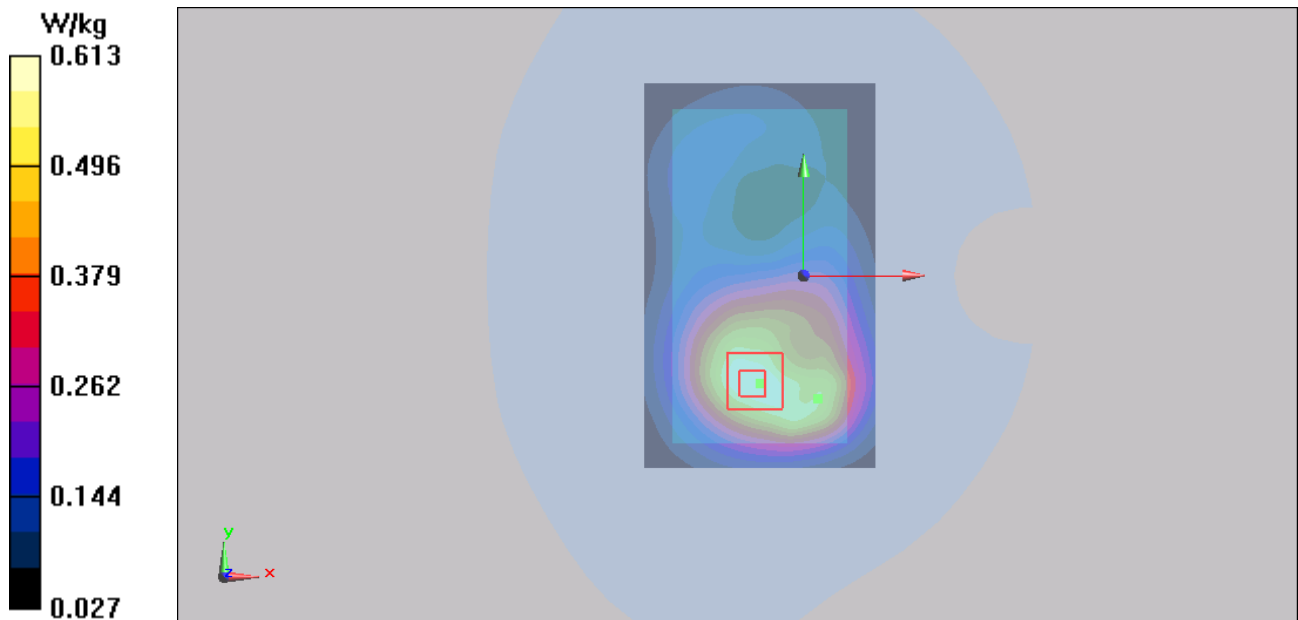

Figure 41 Body, Back Side, UMTS Band II Channel 9538

UMTS Band II Back Side Middle (Hotspot Closed,15mm)

Date/Time: 7/18/2013 8:01:30 PM

Communication System: WCDMA; Frequency: 1880 MHz; Duty Cycle: 1:1

Medium parameters used: $f = 1880$ MHz; $\sigma = 1.503$ mho/m; $\epsilon_r = 52.61$; $\rho = 1000$ kg/m³

Ambient Temperature: 22.3 °C Liquid Temperature: 21.5 °C

Phantom section: Flat Section

DASY5 Configuration:

Sensor-Surface: 4mm (Mechanical Surface Detection)

Probe: EX3DV4 - SN3753; ConvF(7.33, 7.33, 7.33); Calibrated: 1/17/2013;

Electronics: DAE4 Sn1317; Calibrated: 1/25/2013

Phantom: SAM 2; Type: SAM;

Measurement SW: DASY52, Version 52.8 (2); SEMCAD X Version 14.6.6 (6824)

Back Side Middle /Area Scan (7x11x1): Measurement grid: dx=15mm, dy=15mm

Maximum value of SAR (measured) = 0.649 W/kg

Back Side Middle /Zoom Scan (5x5x7)/Cube 0: Measurement grid: dx=8mm, dy=8mm, dz=5mm

Reference Value = 8.645 V/m; Power Drift = -0.11 dB

Peak SAR (extrapolated) = 0.980 mW/g

SAR(1 g) = 0.637 mW/g; SAR(10 g) = 0.407 mW/g

Maximum value of SAR (measured) = 0.682 W/kg

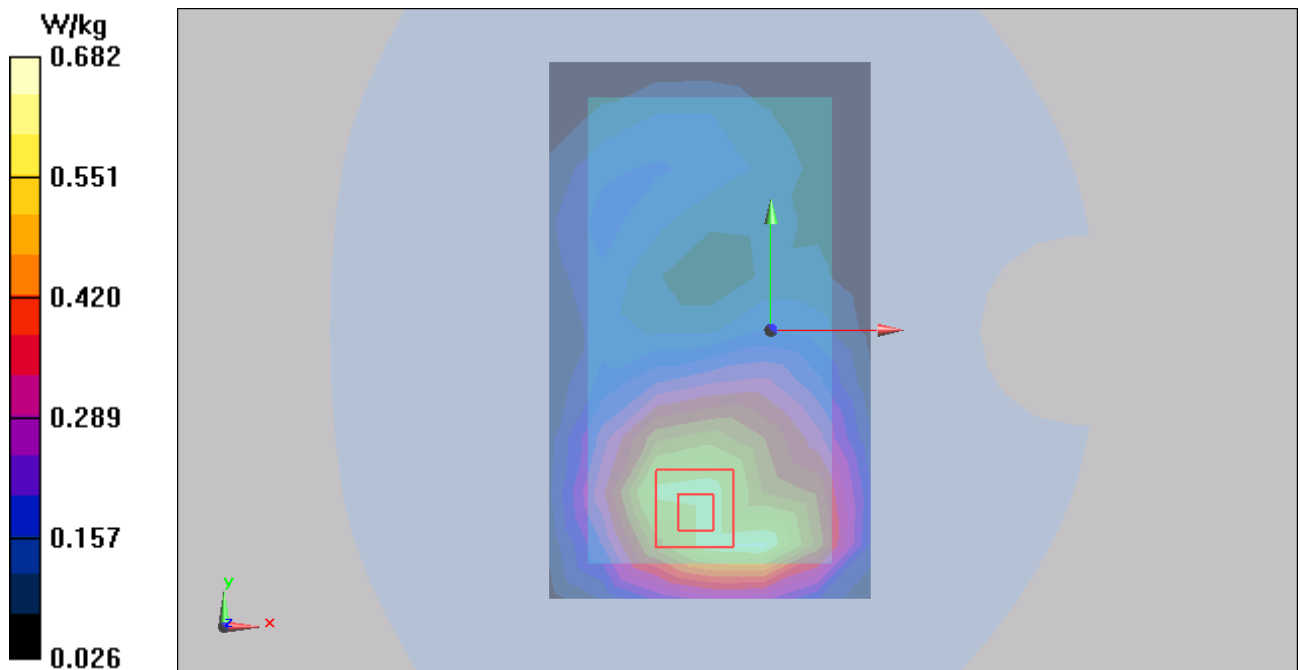

Figure 42 Body, Back Side, UMTS Band II Channel 9400

TA Technology (Shanghai) Co., Ltd. Test Report

Report No.: RXA1307-0093SAR01R3

Page 107 of 225

UMTS Band II Back Side Low (Hotspot Closed,15mm)

Date/Time: 7/18/2013 2:33:40 PM

Communication System: WCDMA; Frequency: 1852.4 MHz; Duty Cycle: 1:1

Medium parameters used (interpolated): $f = 1852.4$ MHz; $\sigma = 1.474$ mho/m; $\epsilon_r = 52.662$; $\rho = 1000$ kg/m³

Ambient Temperature: 22.3 °C Liquid Temperature: 21.5 °C

Phantom section: Flat Section

DASY5 Configuration:

Sensor-Surface: 4mm (Mechanical Surface Detection)

Probe: EX3DV4 - SN3753; ConvF(7.33, 7.33, 7.33); Calibrated: 1/17/2013;

Electronics: DAE4 Sn1317; Calibrated: 1/25/2013

Phantom: SAM 2; Type: SAM;

Measurement SW: DASY52, Version 52.8 (2); SEMCAD X Version 14.6.6 (6824)

Back Side Low /Area Scan (61x101x1): Interpolated grid: dx=15 mm, dy=15 mm

Maximum value of SAR (interpolated) = 0.723 W/kg

Back Side Low /Zoom Scan (5x5x7)/Cube 0: Measurement grid: dx=8mm, dy=8mm, dz=5mm

Reference Value = 10.790 V/m; Power Drift = -0.05 dB

Peak SAR (extrapolated) = 0.992 mW/g

SAR(1 g) = 0.658 mW/g; SAR(10 g) = 0.428 mW/g

Maximum value of SAR (measured) = 0.700 W/kg

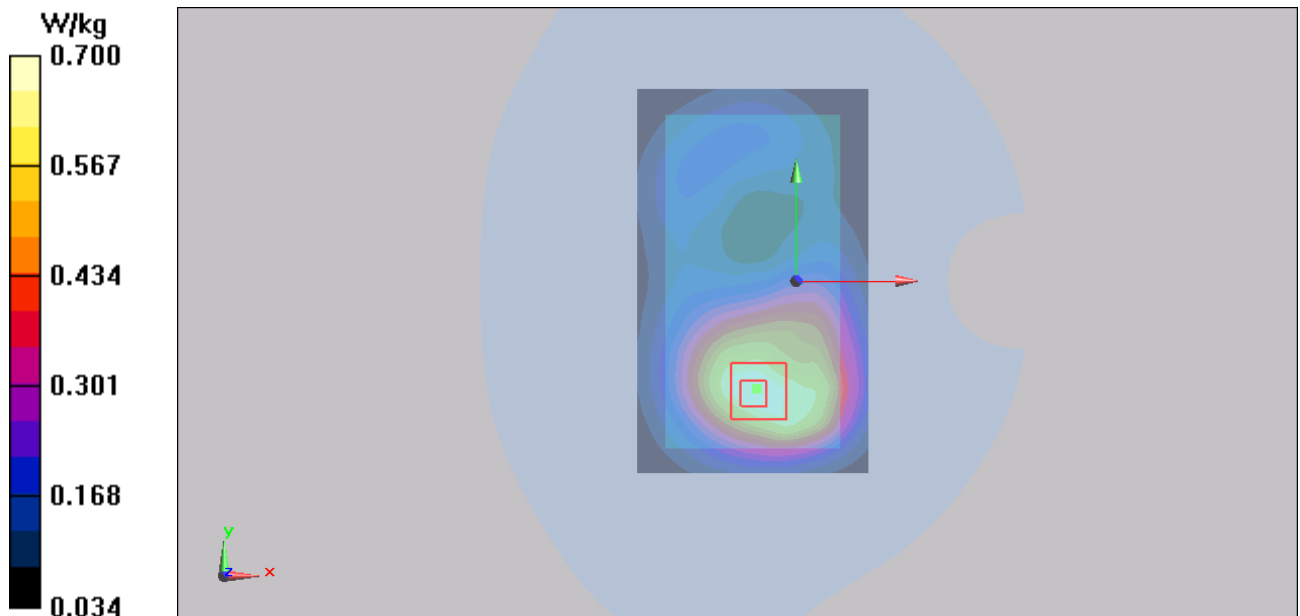

Figure 43 Body, Back Side, UMTS Band II Channel 9262

TA Technology (Shanghai) Co., Ltd. Test Report

Report No.: RXA1307-0093SAR01R3

Page 108 of 225

UMTS Band II Front Side Middle (Hotspot Closed,15mm)

Date/Time: 7/18/2013 8:19:41 PM

Communication System: WCDMA; Frequency: 1880 MHz; Duty Cycle: 1:1

Medium parameters used: $f = 1880$ MHz; $\sigma = 1.503$ mho/m; $\epsilon_r = 52.61$; $\rho = 1000$ kg/m³

Ambient Temperature: 22.3 °C Liquid Temperature: 21.5 °C

Phantom section: Flat Section

DASY5 Configuration:

Sensor-Surface: 4mm (Mechanical Surface Detection)

Probe: EX3DV4 - SN3753; ConvF(7.33, 7.33, 7.33); Calibrated: 1/17/2013;

Electronics: DAE4 Sn1317; Calibrated: 1/25/2013

Phantom: SAM 2; Type: SAM;

Measurement SW: DASY52, Version 52.8 (2); SEMCAD X Version 14.6.6 (6824)

Front Side Middle /Area Scan (7x11x1): Measurement grid: dx=15mm, dy=15mm

Maximum value of SAR (measured) = 0.451 W/kg

Front Side Middle /Zoom Scan (5x5x7)/Cube 0: Measurement grid: dx=8mm, dy=8mm, dz=5mm

Reference Value = 7.716 V/m; Power Drift = -0.05 dB

Peak SAR (extrapolated) = 0.703 mW/g

SAR(1 g) = 0.457 mW/g; SAR(10 g) = 0.287 mW/g

Maximum value of SAR (measured) = 0.490 W/kg

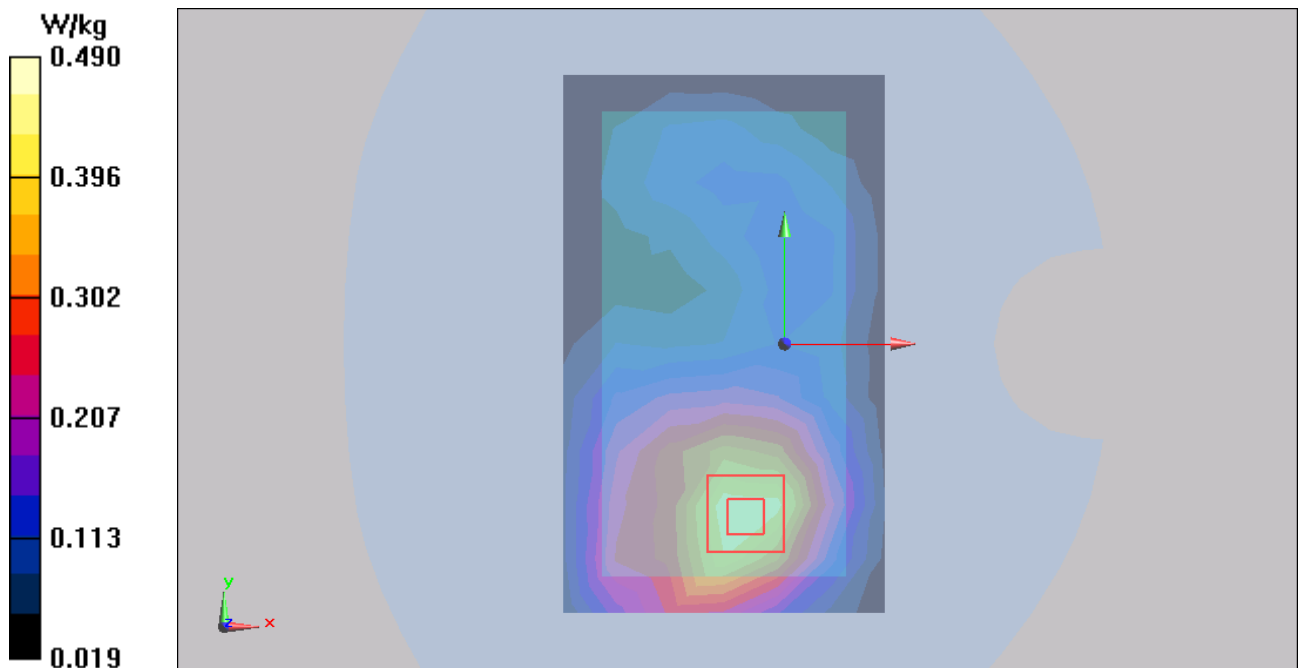

Figure 44 Body, Front Side, UMTS Band II Channel 9400

TA Technology (Shanghai) Co., Ltd. Test Report

Report No.: RXA1307-0093SAR01R3

Page 109 of 225

UMTS Band II Back Side High (Hotspot Open,10mm)

Date/Time: 7/18/2013 7:09:01 PM

Communication System: WCDMA; Frequency: 1907.6 MHz; Duty Cycle: 1:1

Medium parameters used: $f = 1908$ MHz; $\sigma = 1.532$ mho/m; $\epsilon_r = 52.533$; $\rho = 1000$ kg/m³

Ambient Temperature: 22.3 °C Liquid Temperature: 21.5 °C

Phantom section: Flat Section

DASY5 Configuration:

Sensor-Surface: 4mm (Mechanical Surface Detection)

Probe: EX3DV4 - SN3753; ConvF(7.33, 7.33, 7.33); Calibrated: 1/17/2013;

Electronics: DAE4 Sn1317; Calibrated: 1/25/2013

Phantom: SAM 2; Type: SAM;

Measurement SW: DASY52, Version 52.8 (2); SEMCAD X Version 14.6.6 (6824)

Back Side High /Area Scan (7x11x1): Measurement grid: dx=15mm, dy=15mm

Maximum value of SAR (measured) = 0.724 W/kg

Back Side High /Zoom Scan (5x5x7)/Cube 0: Measurement grid: dx=8mm, dy=8mm, dz=5mm

Reference Value = 10.702 V/m; Power Drift = -0.02 dB

Peak SAR (extrapolated) = 1.201 mW/g

SAR(1 g) = 0.706 mW/g; SAR(10 g) = 0.427 mW/g

Maximum value of SAR (measured) = 0.790 W/kg

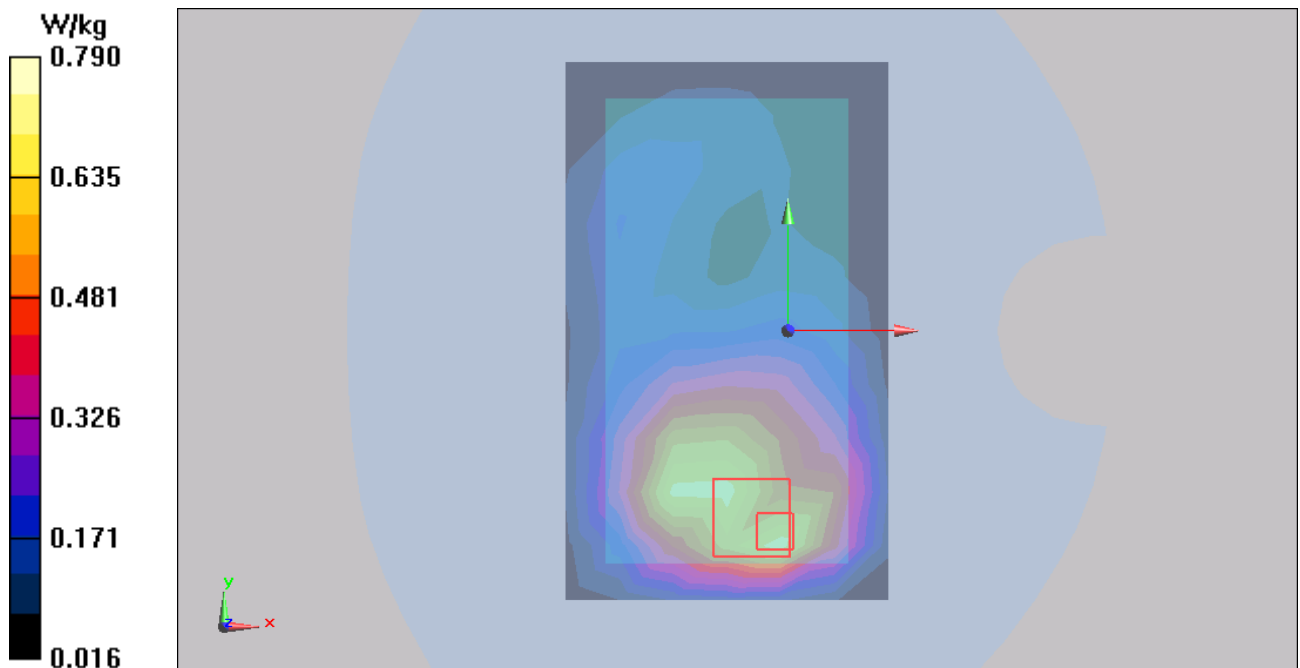

Figure 45 Body, Back Side, UMTS Band II Channel 9538

UMTS Band II Back Side Middle (Hotspot Open,10mm)

Date/Time: 7/18/2013 6:32:31 PM

Communication System: WCDMA; Frequency: 1880 MHz;Duty Cycle: 1:1

Medium parameters used: $f = 1880$ MHz; $\sigma = 1.503$ mho/m; $\epsilon_r = 52.61$; $\rho = 1000$ kg/m³

Ambient Temperature:22.3 °C Liquid Temperature: 21.5°C

Phantom section: Flat Section

DASY5 Configuration:

Sensor-Surface: 4mm (Mechanical Surface Detection)

Probe: EX3DV4 - SN3753; ConvF(7.33, 7.33, 7.33); Calibrated: 1/17/2013;

Electronics: DAE4 Sn1317; Calibrated: 1/25/2013

Phantom: SAM 2; Type: SAM;

Measurement SW: DASY52, Version 52.8 (2); SEMCAD X Version 14.6.6 (6824)

Back Side Middle /Area Scan (7x11x1): Measurement grid: dx=15mm, dy=15mm

Maximum value of SAR (measured) = 0.786 W/kg

Back Side Middle /Zoom Scan (5x5x7)/Cube 0: Measurement grid: dx=8mm, dy=8mm, dz=5mm

Reference Value = 10.829 V/m; Power Drift = -0.049 dB

Peak SAR (extrapolated) = 1.277 mW/g

SAR(1 g) = 0.760 mW/g; SAR(10 g) = 0.464 mW/g

Maximum value of SAR (measured) = 0.851 W/kg

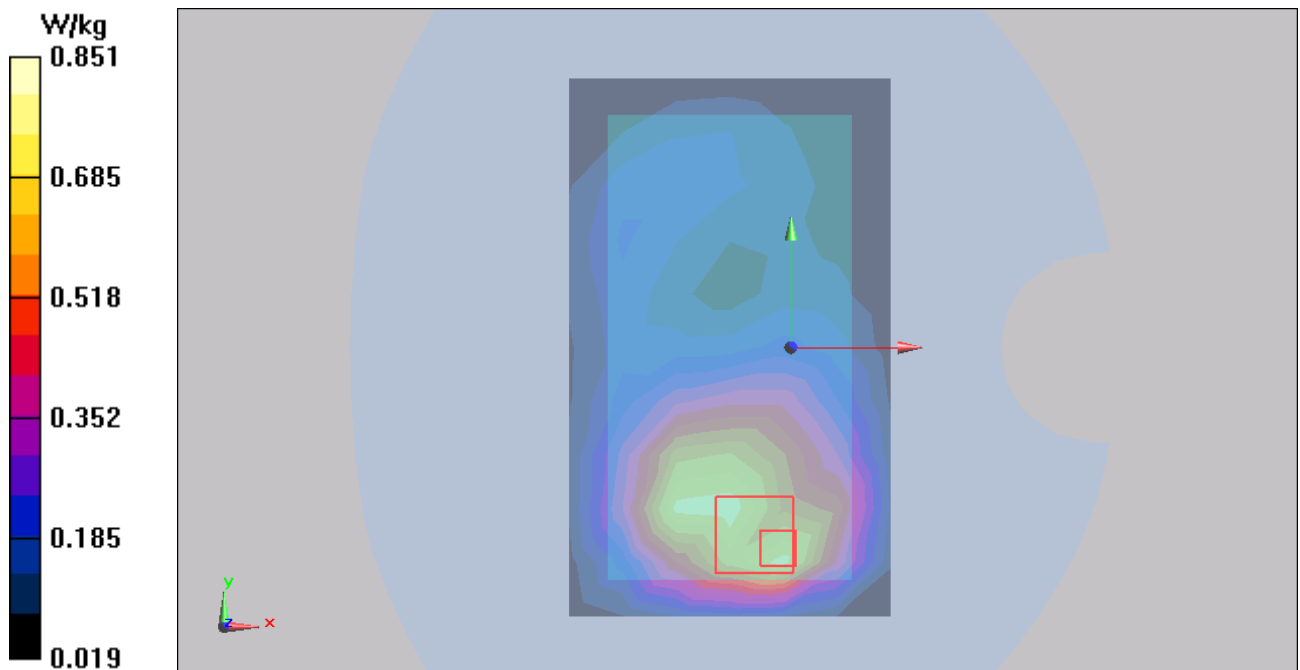

Figure 46 Body, Back Side, UMTS Band II Channel 9400

TA Technology (Shanghai) Co., Ltd. Test Report

Report No.: RXA1307-0093SAR01R3

Page 111 of 225

UMTS Band II Back Side Low (Hotspot Open,10mm)

Date/Time: 7/18/2013 6:50:34 PM

Communication System: WCDMA; Frequency: 1852.4 MHz; Duty Cycle: 1:1

Medium parameters used (interpolated): $f = 1852.4$ MHz; $\sigma = 1.474$ mho/m; $\epsilon_r = 52.662$; $\rho = 1000$ kg/m³

Ambient Temperature: 22.3 °C Liquid Temperature: 21.5 °C

Phantom section: Flat Section

DASY5 Configuration:

Sensor-Surface: 4mm (Mechanical Surface Detection)

Probe: EX3DV4 - SN3753; ConvF(7.33, 7.33, 7.33); Calibrated: 1/17/2013;

Electronics: DAE4 Sn1317; Calibrated: 1/25/2013

Phantom: SAM 2; Type: SAM;

Measurement SW: DASY52, Version 52.8 (2); SEMCAD X Version 14.6.6 (6824)

Back Side Low /Area Scan (7x11x1): Measurement grid: dx=15mm, dy=15mm

Maximum value of SAR (measured) = 0.797 W/kg

Back Side Low /Zoom Scan (5x5x7)/Cube 0: Measurement grid: dx=8mm, dy=8mm, dz=5mm

Reference Value = 9.532 V/m; Power Drift = -0.12 dB

Peak SAR (extrapolated) = 1.244 mW/g

SAR(1 g) = 0.772 mW/g; SAR(10 g) = 0.476 mW/g

Maximum value of SAR (measured) = 0.846 W/kg

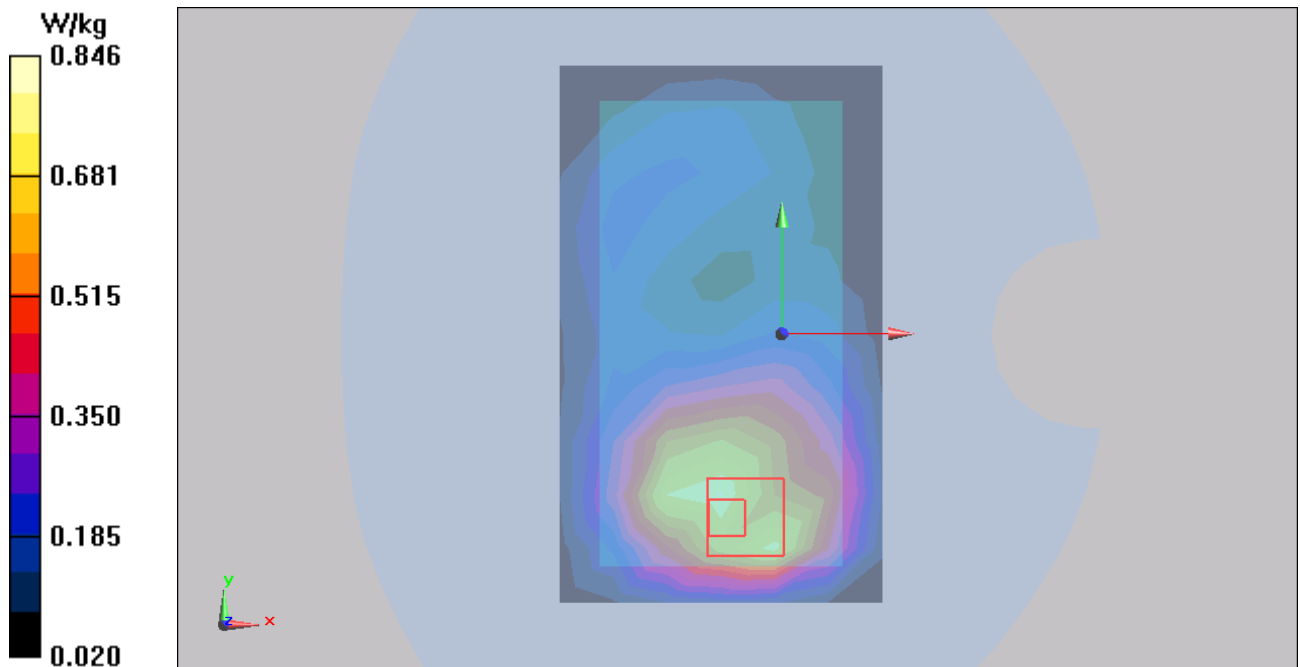

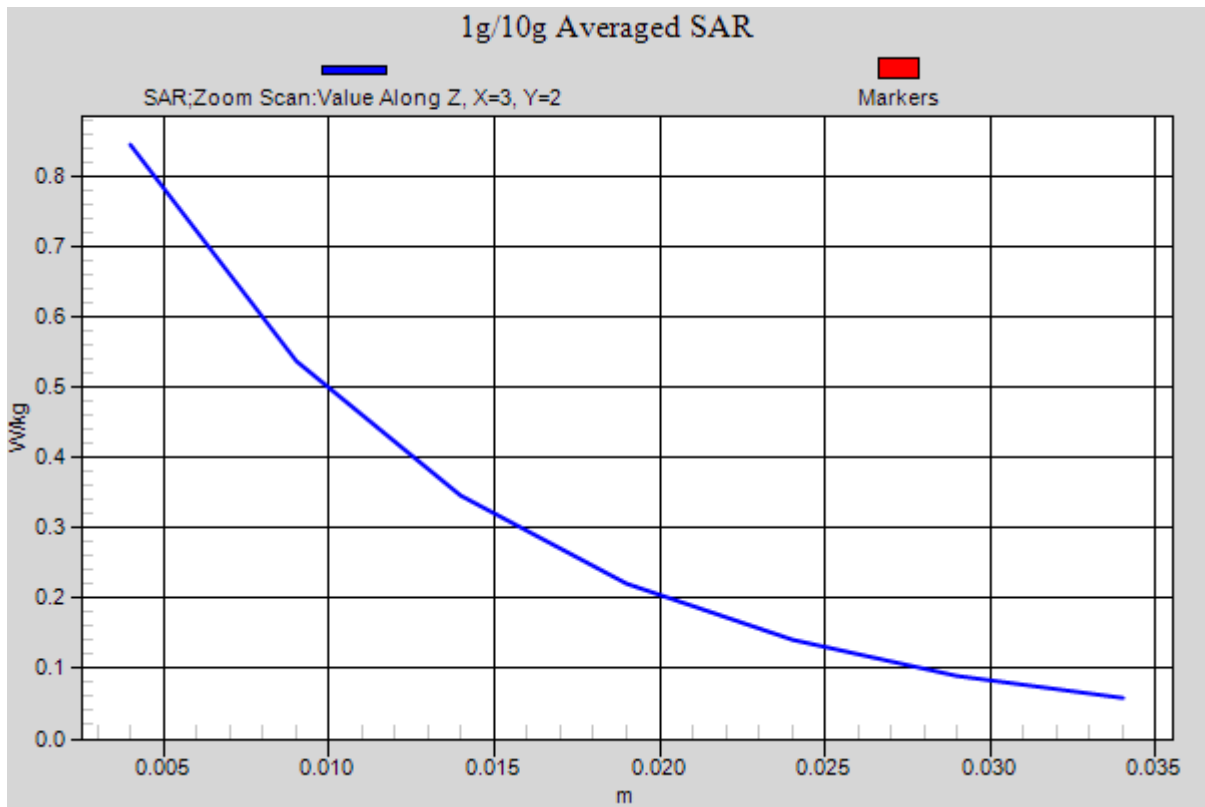

Figure 47 Body, Back Side, UMTS Band II Channel 9262

TA Technology (Shanghai) Co., Ltd. Test Report

Report No.: RXA1307-0093SAR01R3

Page 113 of 225

UMTS Band II Front Side Middle (Hotspot Open,10mm)

Date/Time: 7/18/2013 8:45:49 PM

Communication System: WCDMA; Frequency: 1880 MHz; Duty Cycle: 1:1

Medium parameters used: $f = 1880$ MHz; $\sigma = 1.503$ mho/m; $\epsilon_r = 52.61$; $\rho = 1000$ kg/m³

Ambient Temperature: 22.3 °C Liquid Temperature: 21.5 °C

Phantom section: Flat Section

DASY5 Configuration:

Sensor-Surface: 4mm (Mechanical Surface Detection)

Probe: EX3DV4 - SN3753; ConvF(7.33, 7.33, 7.33); Calibrated: 1/17/2013;

Electronics: DAE4 Sn1317; Calibrated: 1/25/2013

Phantom: SAM 2; Type: SAM;

Measurement SW: DASY52, Version 52.8 (2); SEMCAD X Version 14.6.6 (6824)

Front Side Middle /Area Scan (7x11x1): Measurement grid: dx=15mm, dy=15mm

Maximum value of SAR (measured) = 0.486 W/kg

Front Side Middle /Zoom Scan (5x5x7)/Cube 0: Measurement grid: dx=8mm, dy=8mm, dz=5mm

Reference Value = 8.219 V/m; Power Drift = -0.17 dB

Peak SAR (extrapolated) = 0.754 mW/g

SAR(1 g) = 0.487 mW/g; SAR(10 g) = 0.302 mW/g

Maximum value of SAR (measured) = 0.527 W/kg

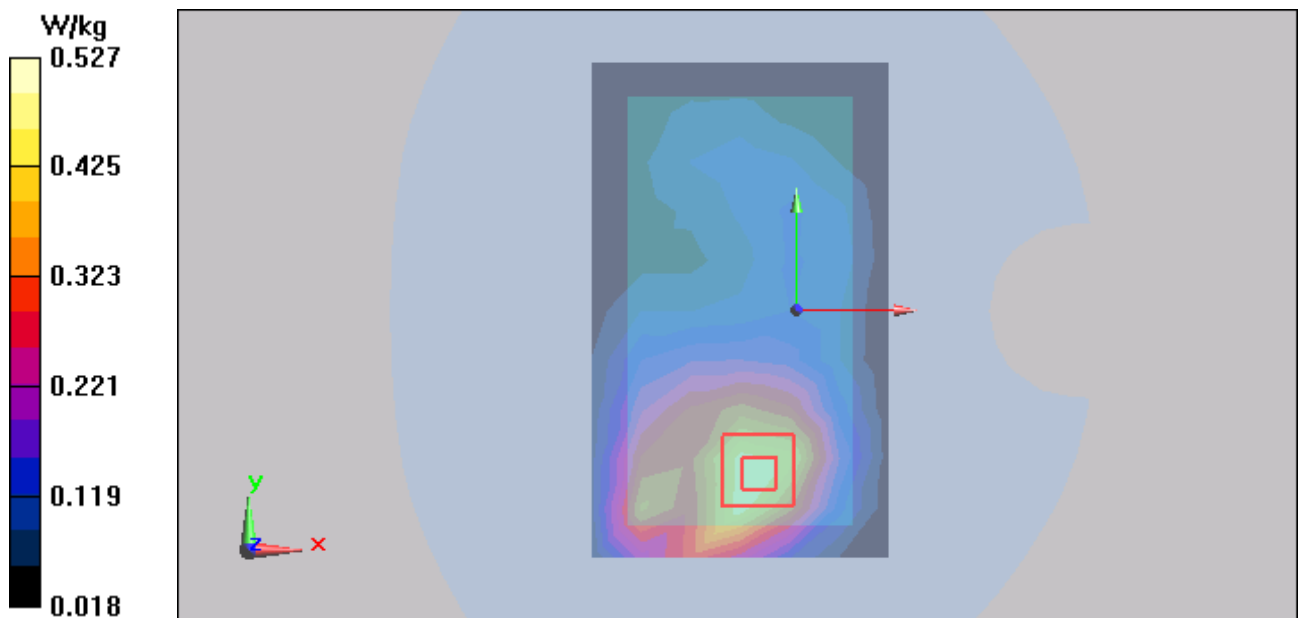

Figure 48 Body, Front Side, UMTS Band II Channel 9400

TA Technology (Shanghai) Co., Ltd. Test Report

Report No.: RXA1307-0093SAR01R3

Page 114 of 225

UMTS Band II Left Edge Middle (Hotspot Open,10mm)

Date/Time: 7/18/2013 3:26:10 AM

Communication System: WCDMA; Frequency: 1880 MHz; Duty Cycle: 1:1

Medium parameters used: $f = 1880$ MHz; $\sigma = 1.503$ mho/m; $\epsilon_r = 52.61$; $\rho = 1000$ kg/m³

Ambient Temperature: 22.3 °C Liquid Temperature: 21.5 °C

Phantom section: Flat Section

DASY5 Configuration:

Sensor-Surface: 4mm (Mechanical Surface Detection)

Probe: EX3DV4 - SN3753; ConvF(7.33, 7.33, 7.33); Calibrated: 1/17/2013;

Electronics: DAE4 Sn1317; Calibrated: 1/25/2013

Phantom: SAM 2; Type: SAM;

Measurement SW: DASY52, Version 52.8 (2); SEMCAD X Version 14.6.6 (6824)

Left Edge Middle /Area Scan (4x12x1): Measurement grid: dx=15mm, dy=15mm

Maximum value of SAR (measured) = 0.297 W/kg

Left Edge Middle /Zoom Scan (5x5x7)/Cube 0: Measurement grid: dx=8mm, dy=8mm, dz=5mm

Reference Value = 8.081 V/m; Power Drift = -0.03 dB

Peak SAR (extrapolated) = 0.535 mW/g

SAR(1 g) = 0.311 mW/g; SAR(10 g) = 0.171 mW/g

Maximum value of SAR (measured) = 0.345 W/kg

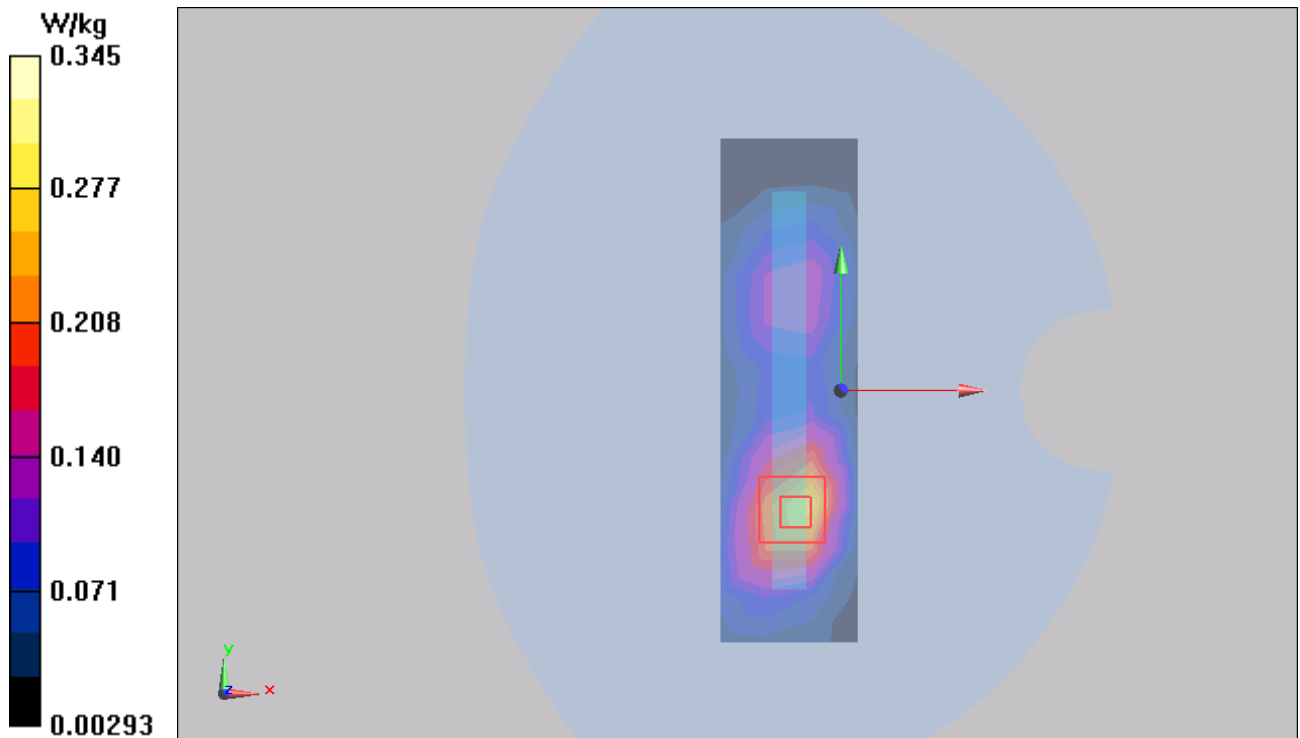

Figure 49 Body, Left Edge, UMTS Band II Channel 9400

TA Technology (Shanghai) Co., Ltd. Test Report

Report No.: RXA1307-0093SAR01R3

Page 115 of 225

UMTS Band II Right Edge Middle (Hotspot Open,10mm)

Date/Time: 7/18/2013 3:43:45 AM

Communication System: WCDMA; Frequency: 1880 MHz; Duty Cycle: 1:1

Medium parameters used: $f = 1880$ MHz; $\sigma = 1.503$ mho/m; $\epsilon_r = 52.61$; $\rho = 1000$ kg/m³

Ambient Temperature: 22.3 °C Liquid Temperature: 21.5 °C

Phantom section: Flat Section

DASY5 Configuration:

Sensor-Surface: 4mm (Mechanical Surface Detection)

Probe: EX3DV4 - SN3753; ConvF(7.33, 7.33, 7.33); Calibrated: 1/17/2013;

Electronics: DAE4 Sn1317; Calibrated: 1/25/2013

Phantom: SAM 2; Type: SAM;

Measurement SW: DASY52, Version 52.8 (2); SEMCAD X Version 14.6.6 (6824)

Right Edge Middle /Area Scan (4x12x1): Measurement grid: dx=15mm, dy=15mm

Maximum value of SAR (measured) = 0.136 W/kg

Right Edge Middle /Zoom Scan (5x5x7)/Cube 0: Measurement grid: dx=8mm, dy=8mm, dz=5mm

Reference Value = 5.916 V/m; Power Drift = -0.08 dB

Peak SAR (extrapolated) = 0.231 mW/g

SAR(1 g) = 0.142 mW/g; SAR(10 g) = 0.082 mW/g

Maximum value of SAR (measured) = 0.157 W/kg

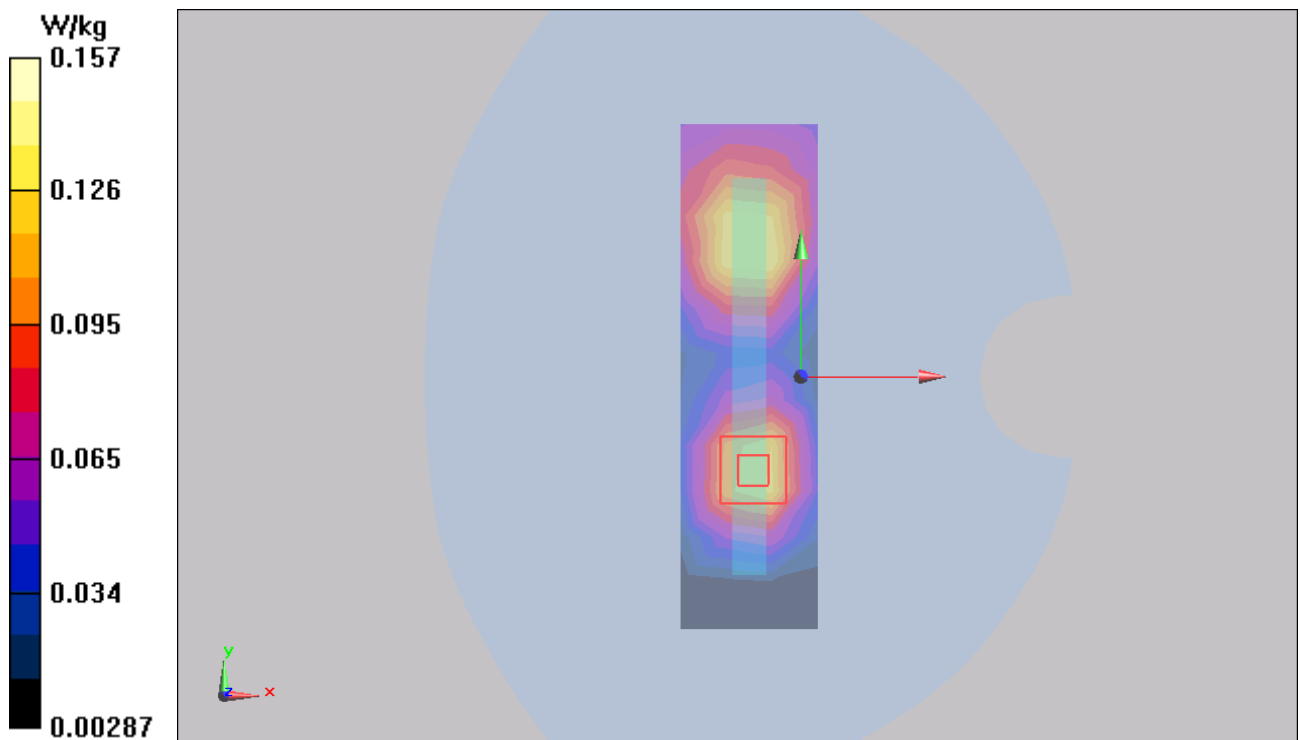

Figure 50 Body, Right Edge, UMTS Band II Channel 9400

TA Technology (Shanghai) Co., Ltd. Test Report

Report No.: RXA1307-0093SAR01R3

Page 116 of 225

UMTS Band II Bottom Edge Middle (Hotspot Open,10mm)

Date/Time: 7/18/2013 4:03:45 AM

Communication System: WCDMA; Frequency: 1880 MHz; Duty Cycle: 1:1

Medium parameters used: $f = 1880$ MHz; $\sigma = 1.503$ mho/m; $\epsilon_r = 52.61$; $\rho = 1000$ kg/m³

Ambient Temperature: 22.3 °C Liquid Temperature: 21.5 °C

Phantom section: Flat Section

DASY5 Configuration:

Sensor-Surface: 4mm (Mechanical Surface Detection)

Probe: EX3DV4 - SN3753; ConvF(7.33, 7.33, 7.33); Calibrated: 1/17/2013;

Electronics: DAE4 Sn1317; Calibrated: 1/25/2013

Phantom: SAM 2; Type: SAM;

Measurement SW: DASY52, Version 52.8 (2); SEMCAD X Version 14.6.6 (6824)

Bottom Edge Middle /Area Scan (4x8x1): Measurement grid: dx=15mm, dy=15mm

Maximum value of SAR (measured) = 0.509 W/kg

Bottom Edge Middle /Zoom Scan (5x5x7)/Cube 0: Measurement grid: dx=8mm, dy=8mm, dz=5mm

Reference Value = 18.655 V/m; Power Drift = 0.08 dB

Peak SAR (extrapolated) = 0.804 mW/g

SAR(1 g) = 0.487 mW/g; SAR(10 g) = 0.286 mW/g

Maximum value of SAR (measured) = 0.528 W/kg

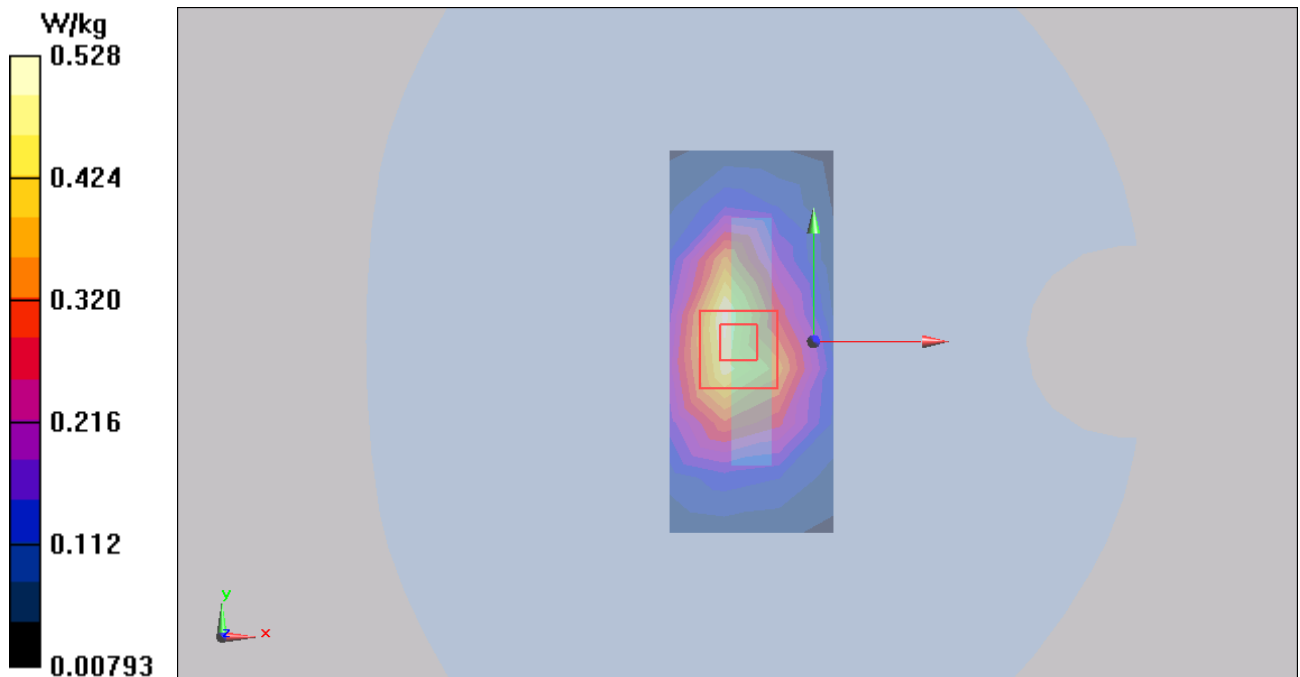

Figure 51 Body, Bottom Edge, UMTS Band II Channel 9400

TA Technology (Shanghai) Co., Ltd. Test Report

Report No.: RXA1307-0093SAR01R3

Page 117 of 225

UMTS Band IV Left Cheek Middle

Date/Time: 7/17/2013 12:48:16 PM

Communication System: WCDMA; Frequency: 1732.6 MHz; Duty Cycle: 1:1

Medium parameters used (interpolated): $f = 1732.6$ MHz; $\sigma = 1.381$ mho/m; $\epsilon_r = 39.221$; $\rho = 1000$ kg/m³

Ambient Temperature: 22.3 °C Liquid Temperature: 21.5 °C

Phantom section: Left Section

DASY5 Configuration:

Sensor-Surface: 4mm (Mechanical Surface Detection)

Probe: EX3DV4 - SN3753; ConvF(7.86, 7.86, 7.86); Calibrated: 1/17/2013;

Electronics: DAE4 Sn1317; Calibrated: 1/25/2013

Phantom: SAM 2; Type: SAM;

Measurement SW: DASY52, Version 52.8 (2); SEMCAD X Version 14.6.6 (6824)

Left Cheek Middle /Area Scan (7x12x1): Measurement grid: dx=15mm, dy=15mm

Maximum value of SAR (measured) = 0.621 W/kg

Left Cheek Middle /Zoom Scan (5x5x7)/Cube 0: Measurement grid: dx=8mm, dy=8mm, dz=5mm

Reference Value = 10.755 V/m; Power Drift = 0.031 dB

Peak SAR (extrapolated) = 0.981 mW/g

SAR(1 g) = 0.644 mW/g; SAR(10 g) = 0.418 mW/g

Maximum value of SAR (measured) = 0.692 W/kg

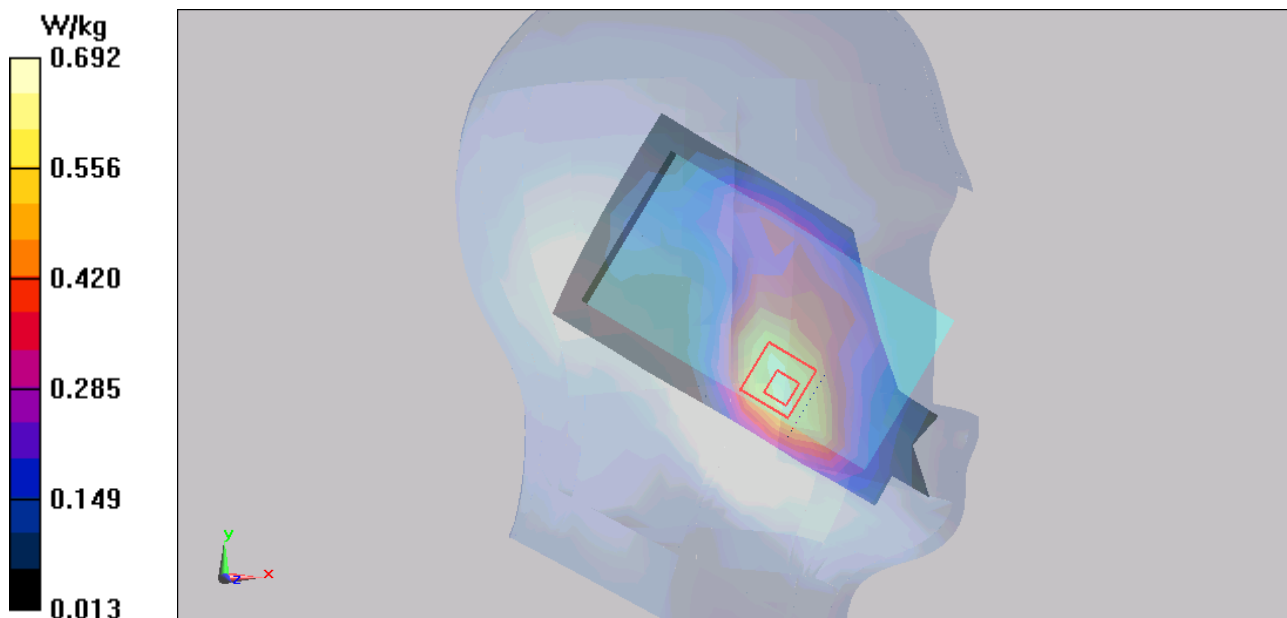

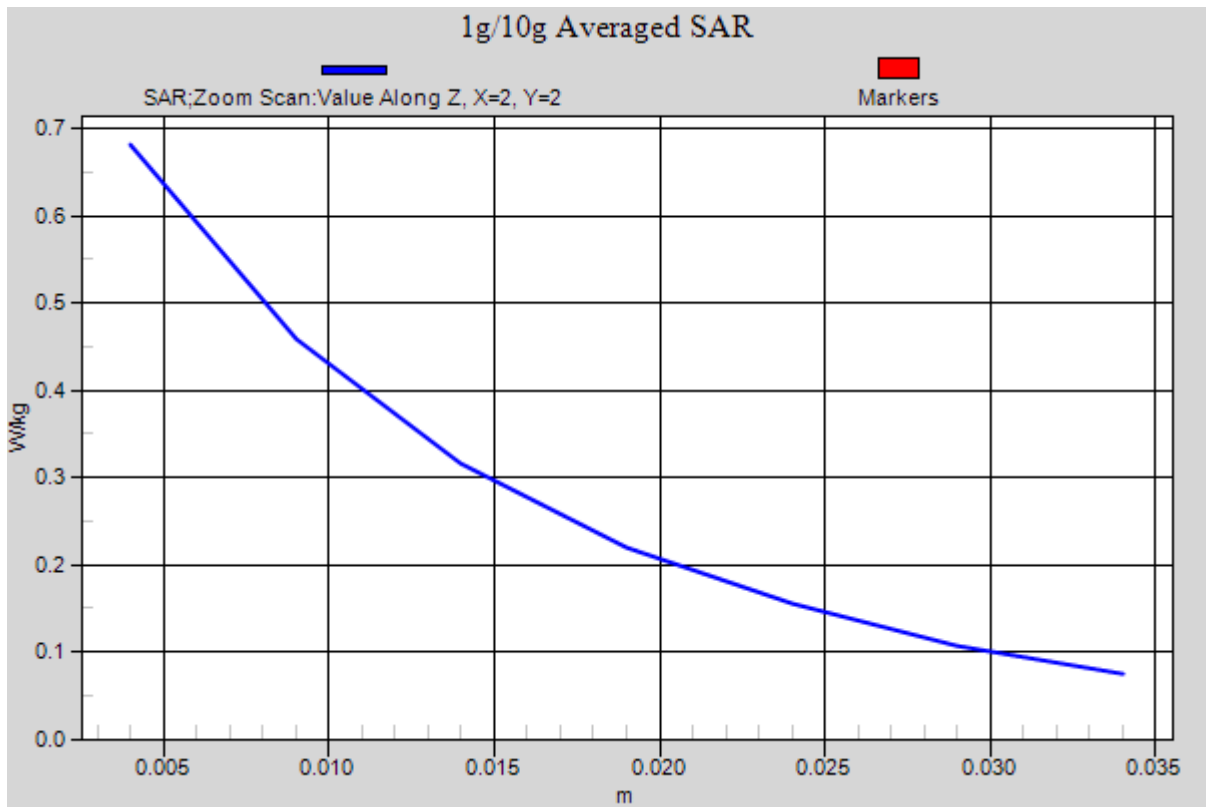

Figure 52 Left Hand Touch Cheek UMTS Band IV Channel 1413

UMTS Band IV Left Tilt Middle

Date/Time: 7/17/2013 1:06:36 PM

Communication System: WCDMA; Frequency: 1732.6 MHz; Duty Cycle: 1:1

Medium parameters used (interpolated): $f = 1732.6$ MHz; $\sigma = 1.381$ mho/m; $\epsilon_r = 39.221$; $\rho = 1000$ kg/m³

Ambient Temperature: 22.3 °C Liquid Temperature: 21.5 °C

Phantom section: Left Section

DASY5 Configuration:

Sensor-Surface: 4mm (Mechanical Surface Detection)

Probe: EX3DV4 - SN3753; ConvF(7.86, 7.86, 7.86); Calibrated: 1/17/2013;

Electronics: DAE4 Sn1317; Calibrated: 1/25/2013

Phantom: SAM 2; Type: SAM;

Measurement SW: DASY52, Version 52.8 (2); SEMCAD X Version 14.6.6 (6824)

Left Tilt Middle /Area Scan (7x12x1): Measurement grid: dx=15mm, dy=15mm

Maximum value of SAR (measured) = 0.222 W/kg

Left Tilt Middle /Zoom Scan (5x5x7)/Cube 0: Measurement grid: dx=8mm, dy=8mm, dz=5mm

Reference Value = 13.303 V/m; Power Drift = 0.17 dB

Peak SAR (extrapolated) = 0.383 mW/g

SAR(1 g) = 0.225 mW/g; SAR(10 g) = 0.132 mW/g

Maximum value of SAR (measured) = 0.247 W/kg

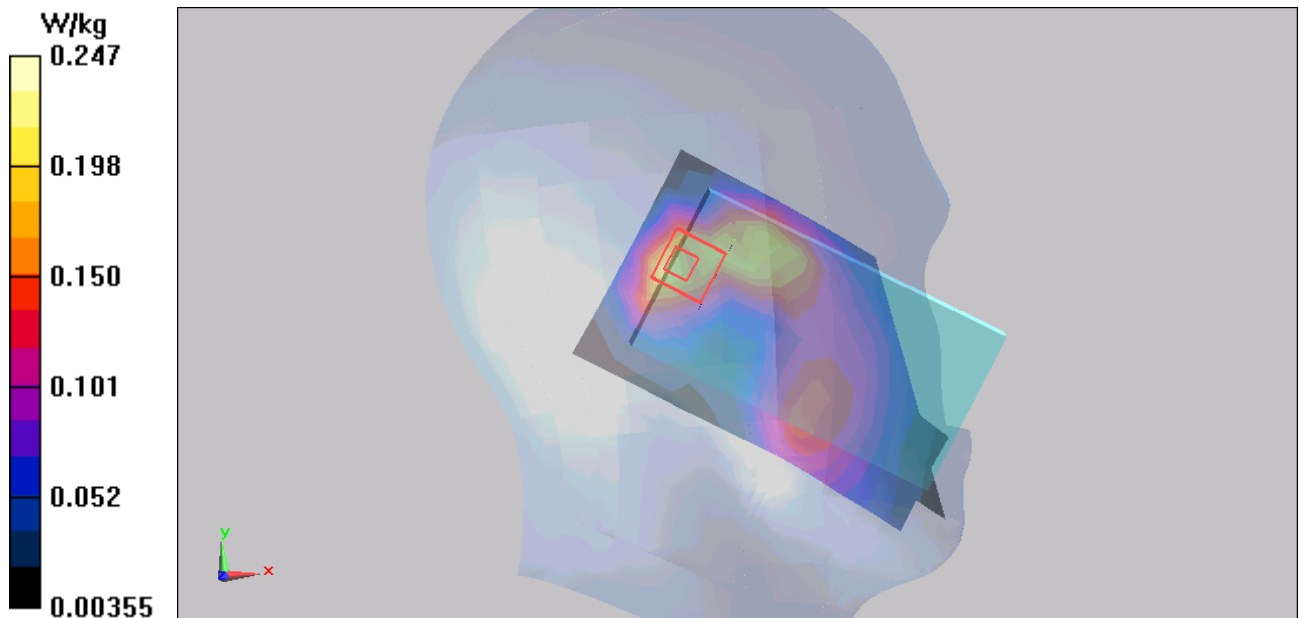

Figure 53 Left Hand Tilt 15° UMTS Band IV Channel 1413

UMTS Band IV Right Cheek Middle

Date/Time: 7/17/2013 12:28:49 PM

Communication System: WCDMA; Frequency: 1732.6 MHz; Duty Cycle: 1:1

Medium parameters used (interpolated): $f = 1732.6$ MHz; $\sigma = 1.381$ mho/m; $\epsilon_r = 39.221$; $\rho = 1000$ kg/m³

Ambient Temperature: 22.3 °C Liquid Temperature: 21.5 °C

Phantom section: Right Section

DASY5 Configuration:

Sensor-Surface: 4mm (Mechanical Surface Detection)

Probe: EX3DV4 - SN3753; ConvF(7.86, 7.86, 7.86); Calibrated: 1/17/2013;

Electronics: DAE4 Sn1317; Calibrated: 1/25/2013

Phantom: SAM 2; Type: SAM;

Measurement SW: DASY52, Version 52.8 (2); SEMCAD X Version 14.6.6 (6824)

Right Cheek Middle /Area Scan (7x12x1): Measurement grid: dx=15mm, dy=15mm

Maximum value of SAR (measured) = 0.573 W/kg

Right Cheek Middle /Zoom Scan (5x5x7)/Cube 0: Measurement grid: dx=8mm, dy=8mm, dz=5mm

Reference Value = 12.507 V/m; Power Drift = 0.03 dB

Peak SAR (extrapolated) = 0.879 mW/g

SAR(1 g) = 0.606 mW/g; SAR(10 g) = 0.403 mW/g

Maximum value of SAR (measured) = 0.651 W/kg

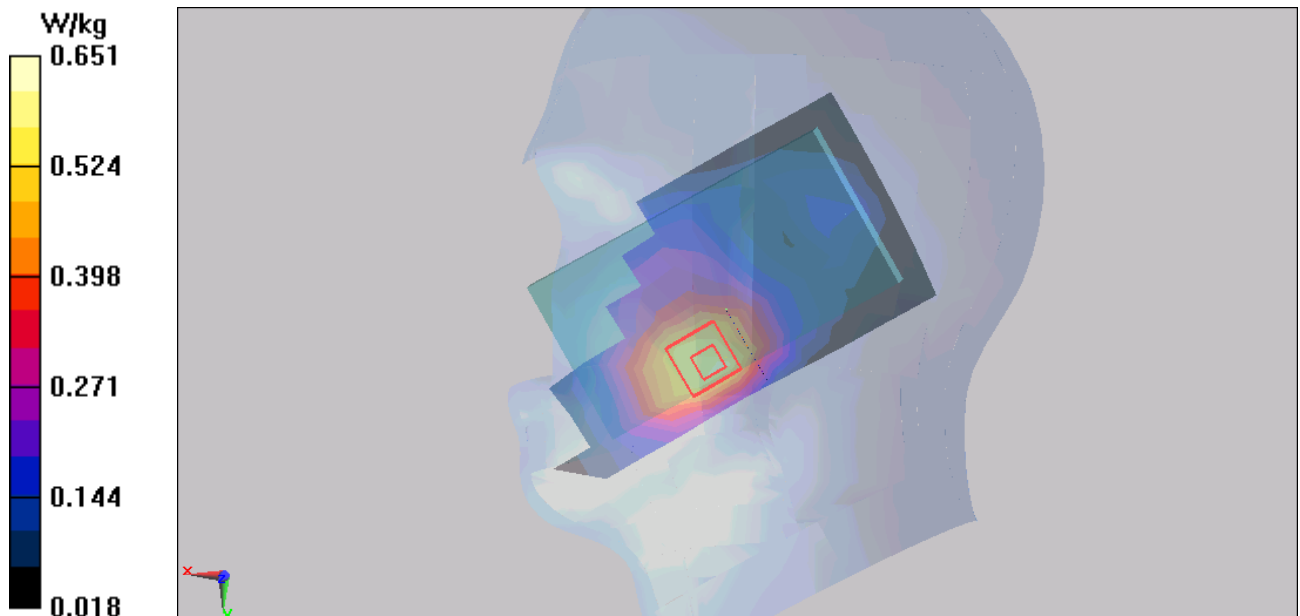

Figure 54 Right Hand Touch Cheek UMTS Band IV Channel 1413

UMTS Band IV Right Tilt Middle

Date/Time: 7/17/2013 1:23:45 PM

Communication System: WCDMA; Frequency: 1732.6 MHz; Duty Cycle: 1:1

Medium parameters used (interpolated): $f = 1732.6$ MHz; $\sigma = 1.381$ mho/m; $\epsilon_r = 39.221$; $\rho = 1000$ kg/m³

Ambient Temperature: 22.3 °C Liquid Temperature: 21.5 °C

Phantom section: Right Section

DASY5 Configuration:

Sensor-Surface: 4mm (Mechanical Surface Detection)

Probe: EX3DV4 - SN3753; ConvF(7.86, 7.86, 7.86); Calibrated: 1/17/2013;

Electronics: DAE4 Sn1317; Calibrated: 1/25/2013

Phantom: SAM 2; Type: SAM;

Measurement SW: DASY52, Version 52.8 (2); SEMCAD X Version 14.6.6 (6824)

Right Tilt Middle /Area Scan (7x12x1): Measurement grid: dx=15mm, dy=15mm

Maximum value of SAR (measured) = 0.239 W/kg

Right Tilt Middle /Zoom Scan (5x5x7)/Cube 0: Measurement grid: dx=8mm, dy=8mm, dz=5mm

Reference Value = 13.993 V/m; Power Drift = 0.13 dB

Peak SAR (extrapolated) = 0.423 mW/g

SAR(1 g) = 0.258 mW/g; SAR(10 g) = 0.143 mW/g

Maximum value of SAR (measured) = 0.290 W/kg

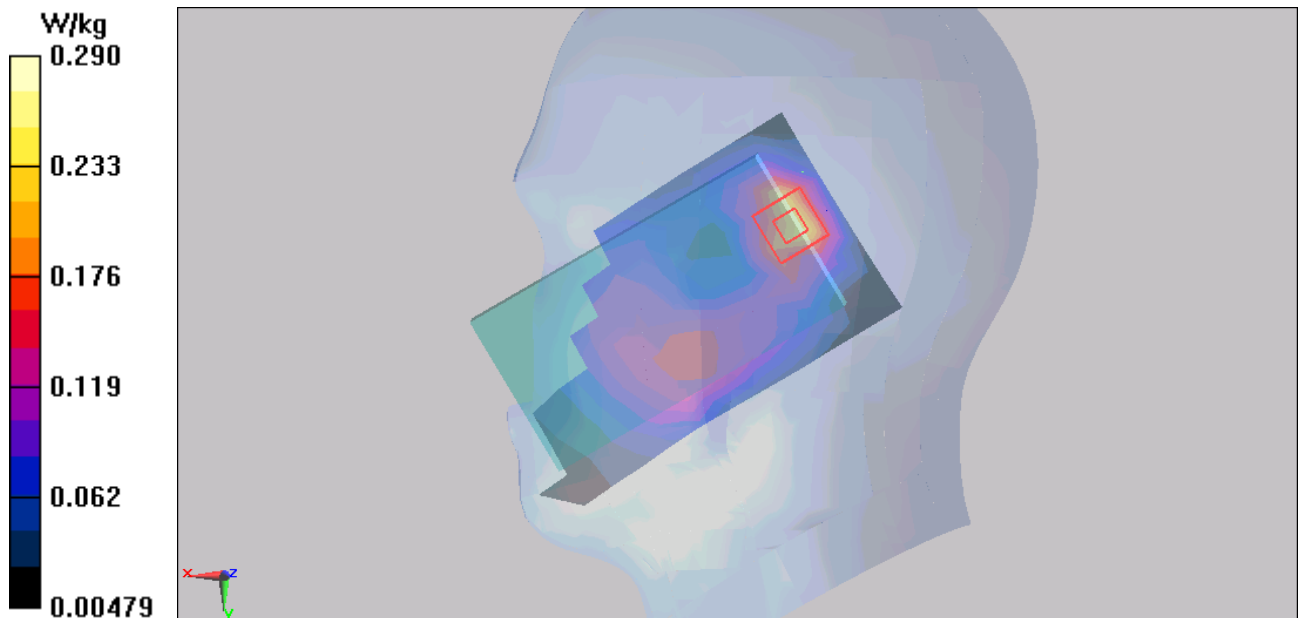

Figure 55 Right Hand Tilt 15° UMTS Band IV Channel 1413

UMTS Band IV Back Side High (Hotspot Closed,15mm)

Date/Time: 7/19/2013 1:55:11 PM

Communication System: WCDMA; Frequency: 1752.6 MHz; Duty Cycle: 1:1

Medium parameters used: $f = 1753$ MHz; $\sigma = 1.471$ mho/m; $\epsilon_r = 52.12$; $\rho = 1000$ kg/m³

Ambient Temperature: 22.3 °C Liquid Temperature: 21.5 °C

Phantom section: Flat Section

DASY5 Configuration:

Sensor-Surface: 4mm (Mechanical Surface Detection)

Probe: EX3DV4 - SN3753; ConvF(7.82, 7.82, 7.82); Calibrated: 1/17/2013;

Electronics: DAE4 Sn1317; Calibrated: 1/25/2013

Phantom: SAM 2; Type: SAM;

Measurement SW: DASY52, Version 52.8 (2); SEMCAD X Version 14.6.6 (6824)

Back Side High /Area Scan (61x101x1): Interpolated grid: dx=15 mm, dy=15 mm

Maximum value of SAR (interpolated) = 0.672 W/kg

Back Side High /Zoom Scan (5x5x7)/Cube 0: Measurement grid: dx=8mm, dy=8mm, dz=5mm

Reference Value = 9.412 V/m; Power Drift = -0.07 dB

Peak SAR (extrapolated) = 0.960 mW/g

SAR(1 g) = 0.634 mW/g; SAR(10 g) = 0.412 mW/g

Maximum value of SAR (measured) = 0.670 W/kg

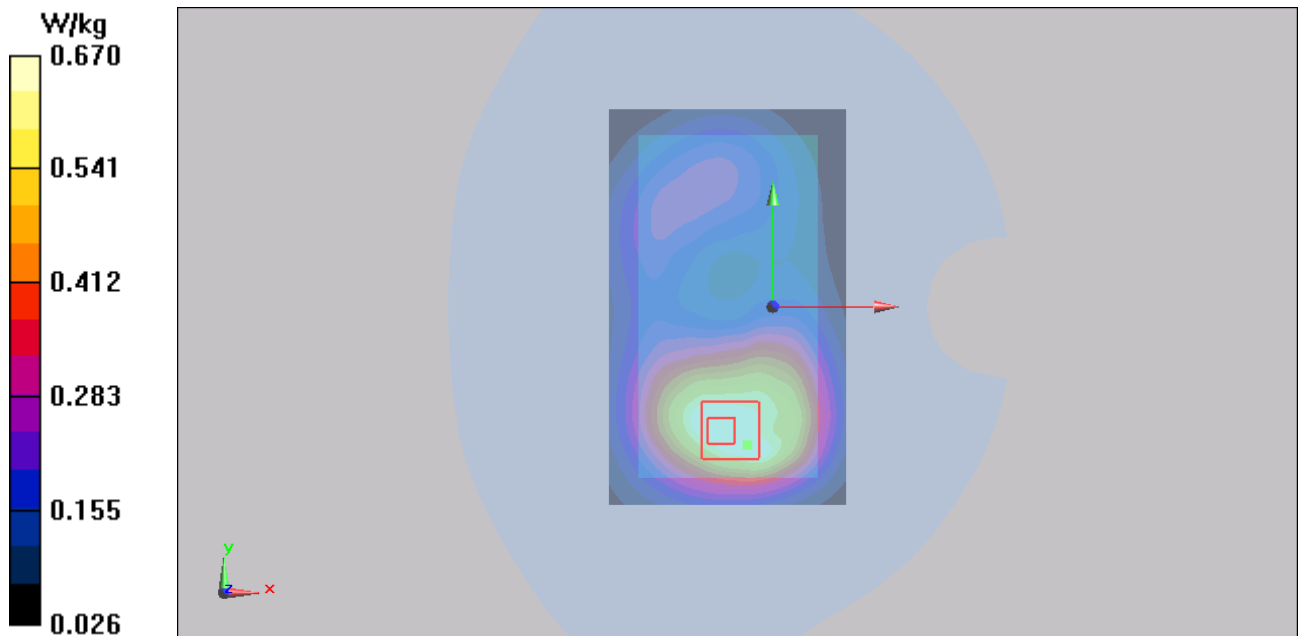

Figure 56 Body, Back Side, UMTS Band IV Channel 1513

TA Technology (Shanghai) Co., Ltd.

Test Report

Report No.: RXA1307-0093SAR01R3

Page 123 of 225

UMTS Band IV Back Side Middle (Hotspot Closed,15mm)

Date/Time: 7/19/2013 1:29:00 PM

Communication System: WCDMA ; Frequency: 1732.6 MHz;Duty Cycle: 1:1

Medium parameters used: $f = 1733$ MHz; $\sigma = 1.454$ mho/m; $\epsilon_r = 52.175$; $\rho = 1000$ kg/m³

Ambient Temperature:22.3 °C Liquid Temperature: 21.5°C

Phantom section: Flat Section

DASY5 Configuration:

Sensor-Surface: 4mm (Mechanical Surface Detection)

Probe: EX3DV4 - SN3753; ConvF(7.82, 7.82, 7.82); Calibrated: 1/17/2013;

Electronics: DAE4 Sn1317; Calibrated: 1/25/2013

Phantom: SAM 2; Type: SAM;

Measurement SW: DASY52, Version 52.8 (2); SEMCAD X Version 14.6.6 (6824)

Back Side Middle /Area Scan (61x101x1): Interpolated grid: dx=15 mm, dy=15 mm

Maximum value of SAR (interpolated) = 0.813 W/kg

Back Side Middle /Zoom Scan (5x5x7)/Cube 1: Measurement grid: dx=8mm, dy=8mm, dz=5mm

Reference Value = 9.029 V/m; Power Drift = 0.041 dB

Peak SAR (extrapolated) = 1.123 mW/g

SAR(1 g) = 0.748 mW/g; SAR(10 g) = 0.489 mW/g

Maximum value of SAR (measured) = 0.800 W/kg

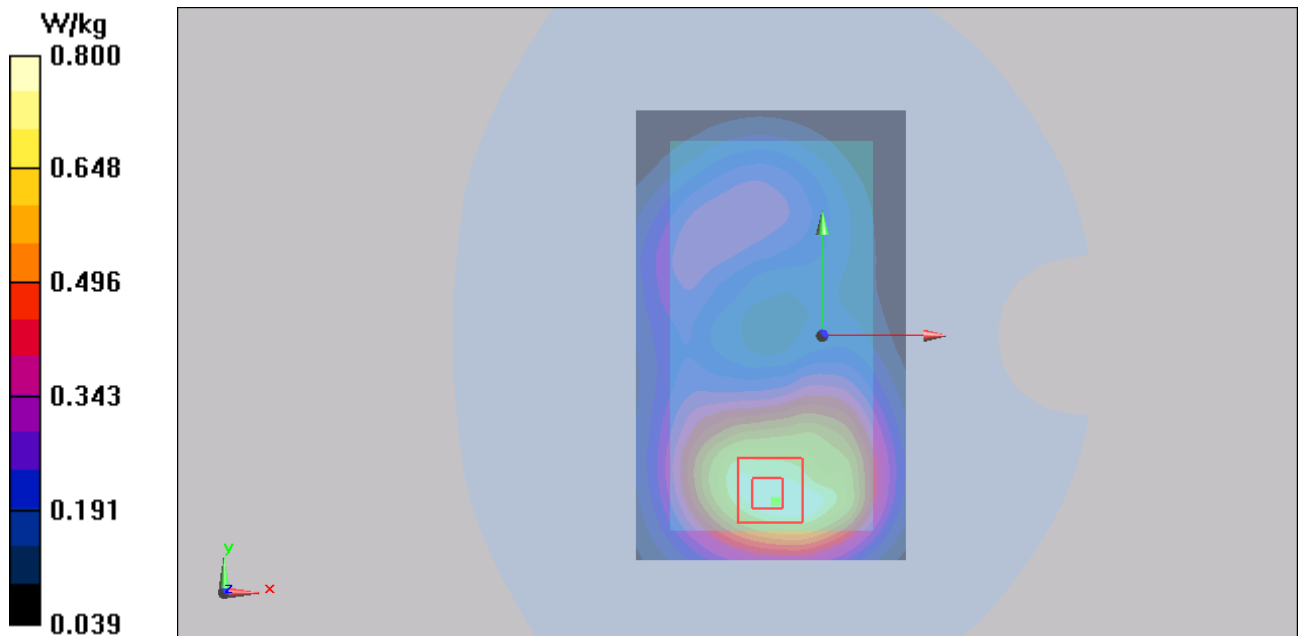

Figure 57 Body, Back Side, UMTS Band IV Channel 1413

UMTS Band IV Back Side Low (Hotspot Closed,15mm)

Date/Time: 7/19/2013 2:11:45 PM

Communication System: WCDMA; Frequency: 1712.4 MHz; Duty Cycle: 1:1

Medium parameters used (interpolated): $f = 1712.4$ MHz; $\sigma = 1.443$ mho/m; $\epsilon_r = 52.223$; $\rho = 1000$ kg/m³

Ambient Temperature: 22.3 °C Liquid Temperature: 21.5 °C

Phantom section: Flat Section

DASY5 Configuration:

Sensor-Surface: 4mm (Mechanical Surface Detection)

Probe: EX3DV4 - SN3753; ConvF(7.82, 7.82, 7.82); Calibrated: 1/17/2013;

Electronics: DAE4 Sn1317; Calibrated: 1/25/2013

Phantom: SAM 2; Type: SAM;

Measurement SW: DASY52, Version 52.8 (2); SEMCAD X Version 14.6.6 (6824)

Back Side Low /Area Scan (61x101x1): Interpolated grid: dx=15 mm, dy=15 mm

Maximum value of SAR (interpolated) = 0.649 W/kg

Back Side Low /Zoom Scan (5x5x7)/Cube 0: Measurement grid: dx=8mm, dy=8mm, dz=5mm

Reference Value = 9.865 V/m; Power Drift = 0.025 dB

Peak SAR (extrapolated) = 0.899 mW/g

SAR(1 g) = 0.595 mW/g; SAR(10 g) = 0.393 mW/g

Maximum value of SAR (measured) = 0.639 W/kg

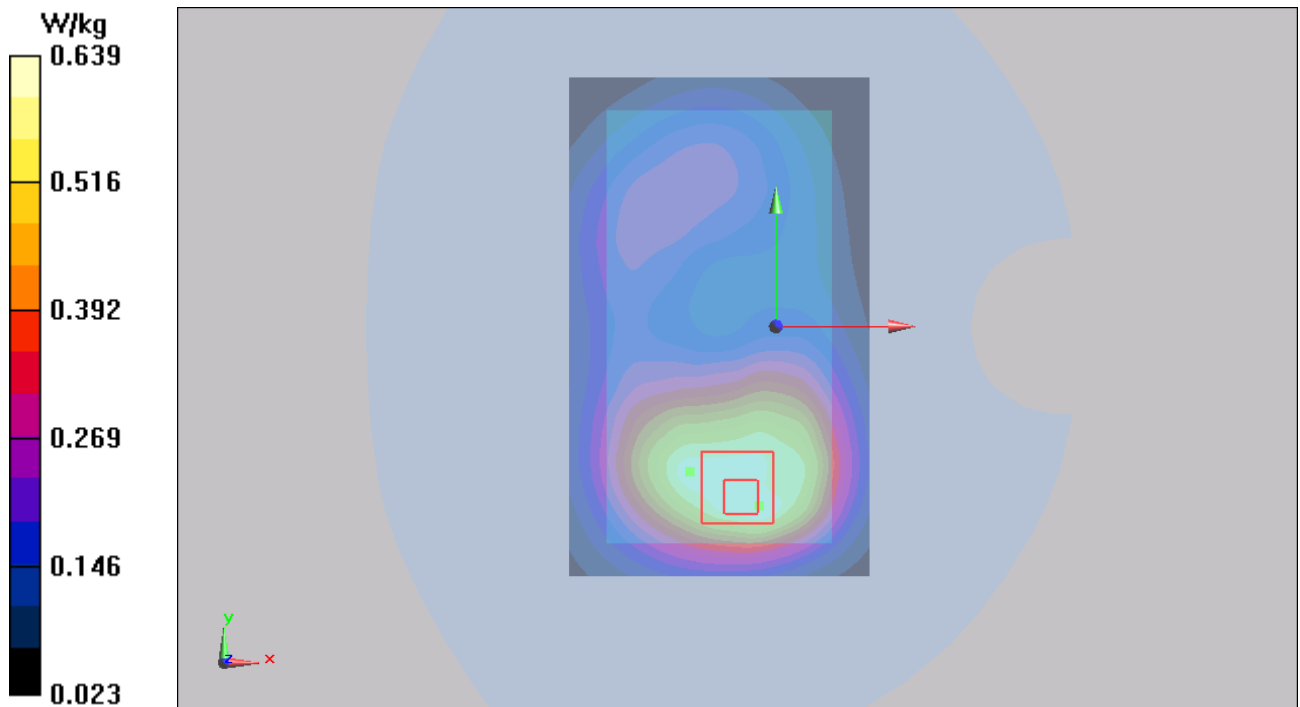

Figure 58 Body, Back Side, UMTS Band IV Channel 1312

TA Technology (Shanghai) Co., Ltd.

Test Report

Report No.: RXA1307-0093SAR01R3

Page 125 of 225

UMTS Band IV Front Side Middle (Hotspot Closed,15mm)

Date/Time: 7/19/2013 12:43:52 PM

Communication System: WCDMA ; Frequency: 1732.6 MHz;Duty Cycle: 1:1

Medium parameters used: $f = 1733$ MHz; $\sigma = 1.454$ mho/m; $\epsilon_r = 52.175$; $\rho = 1000$ kg/m³

Ambient Temperature:22.3 °C Liquid Temperature: 21.5°C

Phantom section: Flat Section

DASY5 Configuration:

Sensor-Surface: 4mm (Mechanical Surface Detection)

Probe: EX3DV4 - SN3753; ConvF(7.82, 7.82, 7.82); Calibrated: 1/17/2013;

Electronics: DAE4 Sn1317; Calibrated: 1/25/2013

Phantom: SAM 2; Type: SAM;

Measurement SW: DASY52, Version 52.8 (2); SEMCAD X Version 14.6.6 (6824)

Front Side Middle /Area Scan (61x101x1): Interpolated grid: dx=15 mm, dy=15 mm

Maximum value of SAR (interpolated) = 0.483 W/kg

Front Side Middle /Zoom Scan (5x5x7)/Cube 0: Measurement grid: dx=8mm, dy=8mm, dz=5mm

Reference Value = 10.222 V/m; Power Drift = -0.04 dB

Peak SAR (extrapolated) = 0.670 mW/g

SAR(1 g) = 0.446 mW/g; SAR(10 g) = 0.289 mW/g

Maximum value of SAR (measured) = 0.471 W/kg

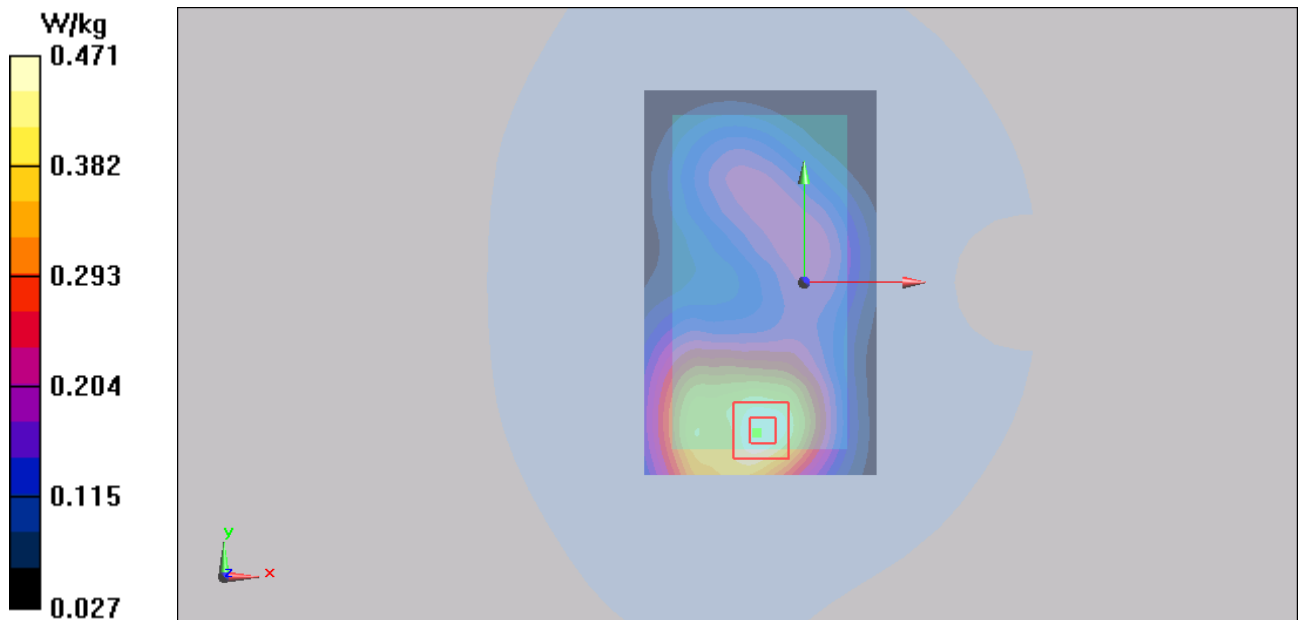

Figure 59 Body, Front Side, UMTS Band IV Channel 1413

TA Technology (Shanghai) Co., Ltd.

Test Report

Report No.: RXA1307-0093SAR01R3

Page 126 of 225

UMTS Band IV Back Side High (Hotspot Open,10mm)

Date/Time: 7/19/2013 3:20:13 PM

Communication System: WCDMA; Frequency: 1752.6 MHz; Duty Cycle: 1:1

Medium parameters used: $f = 1753$ MHz; $\sigma = 1.471$ mho/m; $\epsilon_r = 52.12$; $\rho = 1000$ kg/m³

Ambient Temperature: 22.3 °C Liquid Temperature: 21.5 °C

Phantom section: Flat Section

DASY5 Configuration:

Sensor-Surface: 4mm (Mechanical Surface Detection)

Probe: EX3DV4 - SN3753; ConvF(7.82, 7.82, 7.82); Calibrated: 1/17/2013;

Electronics: DAE4 Sn1317; Calibrated: 1/25/2013

Phantom: SAM 2; Type: SAM;

Measurement SW: DASY52, Version 52.8 (2); SEMCAD X Version 14.6.6 (6824)

Back Side High /Area Scan (61x101x1): Interpolated grid: dx=15 mm, dy=15 mm

Maximum value of SAR (interpolated) = 0.896 W/kg

Back Side High /Zoom Scan (5x5x7)/Cube 0: Measurement grid: dx=8mm, dy=8mm, dz=5mm

Reference Value = 10.744 V/m; Power Drift = -0.07 dB

Peak SAR (extrapolated) = 1.233 mW/g

SAR(1 g) = 0.805 mW/g; SAR(10 g) = 0.513 mW/g

Maximum value of SAR (measured) = 0.864 W/kg

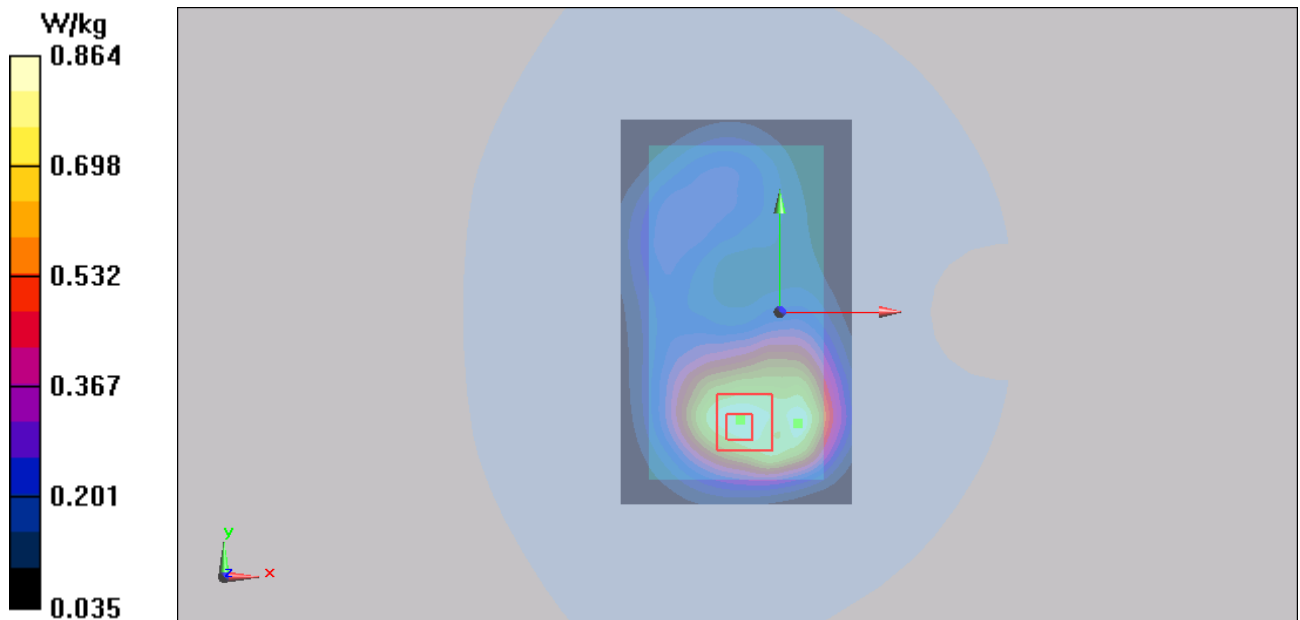

Figure 60 Body, Back Side, UMTS Band IV Channel 1513

UMTS Band IV Back Side Middle (Hotspot Open,10mm)

Date/Time: 7/19/2013 3:59:04 PM

Communication System: WCDMA; Frequency: 1732.6 MHz; Duty Cycle: 1:1

Medium parameters used: $f = 1733$ MHz; $\sigma = 1.454$ mho/m; $\epsilon_r = 52.175$; $\rho = 1000$ kg/m³

Ambient Temperature: 22.3 °C Liquid Temperature: 21.5 °C

Phantom section: Flat Section

DASY5 Configuration:

Sensor-Surface: 4mm (Mechanical Surface Detection)

Probe: EX3DV4 - SN3753; ConvF(7.82, 7.82, 7.82); Calibrated: 1/17/2013;

Electronics: DAE4 Sn1317; Calibrated: 1/25/2013

Phantom: SAM 2; Type: SAM;

Measurement SW: DASY52, Version 52.8 (2); SEMCAD X Version 14.6.6 (6824)

Back Side Middle /Area Scan (61x101x1): Interpolated grid: dx=15 mm, dy=15 mm

Maximum value of SAR (interpolated) = 1.03 W/kg

Back Side Middle /Zoom Scan (5x5x7)/Cube 0: Measurement grid: dx=8mm, dy=8mm, dz=5mm

Reference Value = 11.587 V/m; Power Drift = -0.03 dB

Peak SAR (extrapolated) = 1.392 mW/g

SAR(1 g) = 0.919 mW/g; SAR(10 g) = 0.594 mW/g

Maximum value of SAR (measured) = 0.968 W/kg

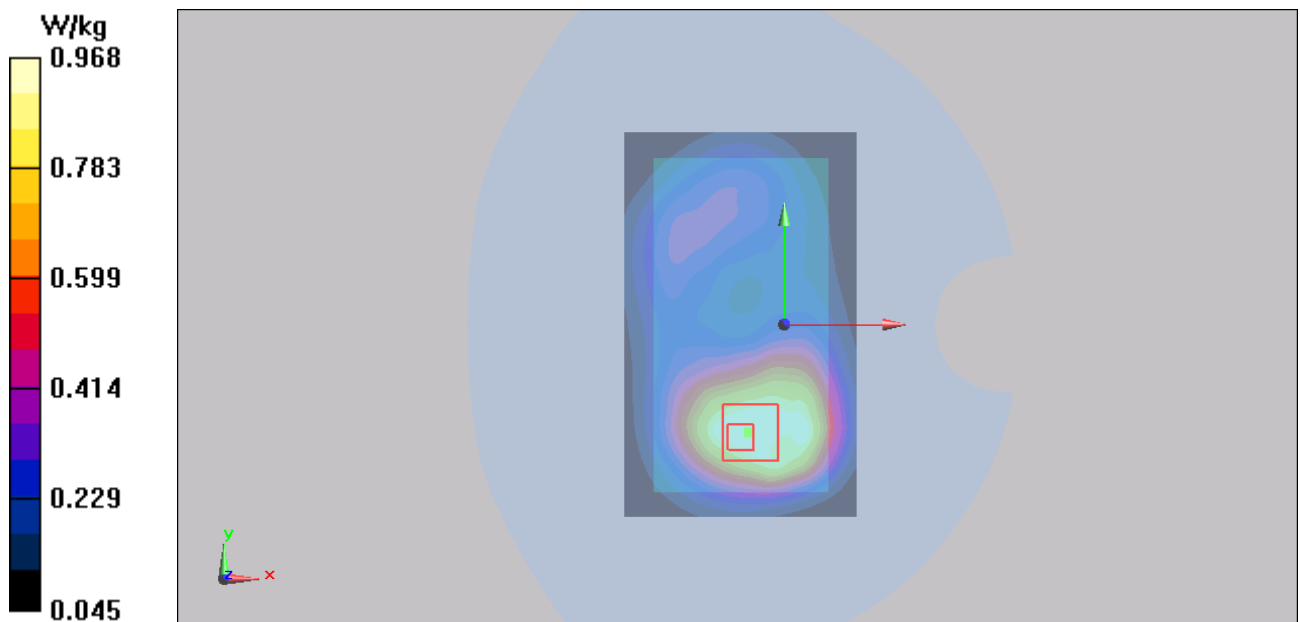

Figure 61 Body, Back Side, UMTS Band IV Channel 1413

TA Technology (Shanghai) Co., Ltd. Test Report

Report No.: RXA1307-0093SAR01R3

Page 128 of 225

UMTS Band IV Back Side Low (Hotspot Open,10mm)

Date/Time: 7/19/2013 2:27:44 PM

Communication System: WCDMA; Frequency: 1712.4 MHz; Duty Cycle: 1:1

Medium parameters used (interpolated): $f = 1712.4$ MHz; $\sigma = 1.443$ mho/m; $\epsilon_r = 52.223$; $\rho = 1000$ kg/m³

Ambient Temperature: 22.3 °C Liquid Temperature: 21.5 °C

Phantom section: Flat Section

DASY5 Configuration:

Sensor-Surface: 4mm (Mechanical Surface Detection)

Probe: EX3DV4 - SN3753; ConvF(7.82, 7.82, 7.82); Calibrated: 1/17/2013;

Electronics: DAE4 Sn1317; Calibrated: 1/25/2013

Phantom: SAM 2; Type: SAM;

Measurement SW: DASY52, Version 52.8 (2); SEMCAD X Version 14.6.6 (6824)

Back Side Low /Area Scan (61x101x1): Interpolated grid: dx=15 mm, dy=15 mm

Maximum value of SAR (interpolated) = 0.718 W/kg

Back Side Low /Zoom Scan (5x5x7)/Cube 0: Measurement grid: dx=8mm, dy=8mm, dz=5mm

Reference Value = 10.705 V/m; Power Drift = 0.048 dB

Peak SAR (extrapolated) = 1.075 mW/g

SAR(1 g) = 0.698 mW/g; SAR(10 g) = 0.450 mW/g

Maximum value of SAR (measured) = 0.757 W/kg

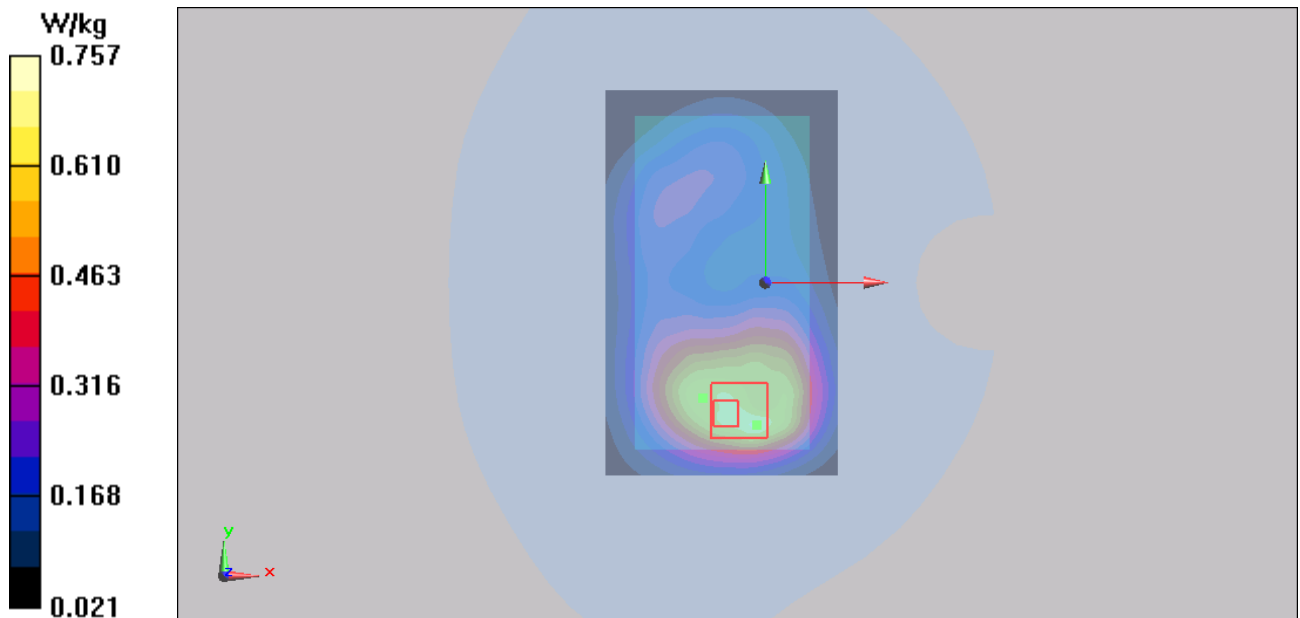

Figure 62 Body, Back Side, UMTS Band IV Channel 1312

TA Technology (Shanghai) Co., Ltd. Test Report

Report No.: RXA1307-0093SAR01R3

Page 129 of 225

UMTS Band IV Front Side Middle (Hotspot Open,10mm)

Date/Time: 7/19/2013 2:55:32 PM

Communication System: WCDMA ; Frequency: 1732.6 MHz;Duty Cycle: 1:1

Medium parameters used: $f = 1733$ MHz; $\sigma = 1.454$ mho/m; $\epsilon_r = 52.175$; $\rho = 1000$ kg/m³

Ambient Temperature:22.3 °C Liquid Temperature: 21.5°C

Phantom section: Flat Section

DASY5 Configuration:

Sensor-Surface: 4mm (Mechanical Surface Detection)

Probe: EX3DV4 - SN3753; ConvF(7.82, 7.82, 7.82); Calibrated: 1/17/2013;

Electronics: DAE4 Sn1317; Calibrated: 1/25/2013

Phantom: SAM 2; Type: SAM;

Measurement SW: DASY52, Version 52.8 (2); SEMCAD X Version 14.6.6 (6824)

Front Side Middle /Area Scan (61x101x1): Interpolated grid: dx=15 mm, dy=15 mm

Maximum value of SAR (interpolated) = 0.598 W/kg

Front Side Middle /Zoom Scan (5x5x7)/Cube 0: Measurement grid: dx=8mm, dy=8mm, dz=5mm

Reference Value = 11.036 V/m; Power Drift = 0.001dB

Peak SAR (extrapolated) = 0.834 mW/g

SAR(1 g) = 0.549 mW/g; SAR(10 g) = 0.350 mW/g

Maximum value of SAR (measured) = 0.586 W/kg

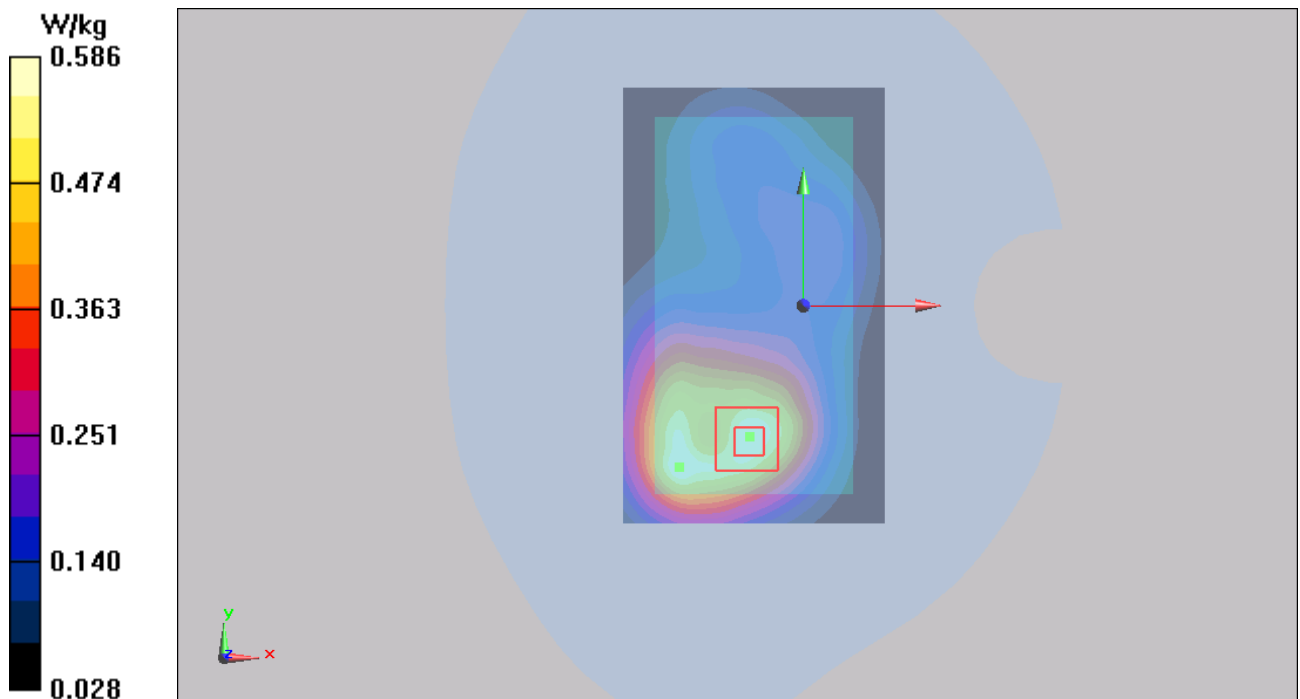

Figure 63 Body, Front Side, UMTS Band IV Channel 1413

UMTS Band IV Left Edge Middle (Hotspot Open,10mm)

Date/Time: 7/19/2013 3:08:46 PM

Communication System: WCDMA ; Frequency: 1732.6 MHz;Duty Cycle: 1:1

Medium parameters used: $f = 1733$ MHz; $\sigma = 1.454$ mho/m; $\epsilon_r = 52.175$; $\rho = 1000$ kg/m³

Ambient Temperature:22.3 °C Liquid Temperature: 21.5°C

Phantom section: Flat Section

DASY5 Configuration:

Sensor-Surface: 4mm (Mechanical Surface Detection)

Probe: EX3DV4 - SN3753; ConvF(7.82, 7.82, 7.82); Calibrated: 1/17/2013;

Electronics: DAE4 Sn1317; Calibrated: 1/25/2013

Phantom: SAM 2; Type: SAM;

Measurement SW: DASY52, Version 52.8 (2); SEMCAD X Version 14.6.6 (6824)

Left Edge Middle /Area Scan (41x101x1): Interpolated grid: dx=15 mm, dy=15 mm

Maximum value of SAR (interpolated) = 0.355 W/kg

Left Edge Middle /Zoom Scan (5x5x7)/Cube 0: Measurement grid: dx=8mm, dy=8mm, dz=5mm

Reference Value = 9.574 V/m; Power Drift = 0.06 dB

Peak SAR (extrapolated) = 0.533 mW/g

SAR(1 g) = 0.316 mW/g; SAR(10 g) = 0.176 mW/g

Maximum value of SAR (measured) = 0.343 W/kg

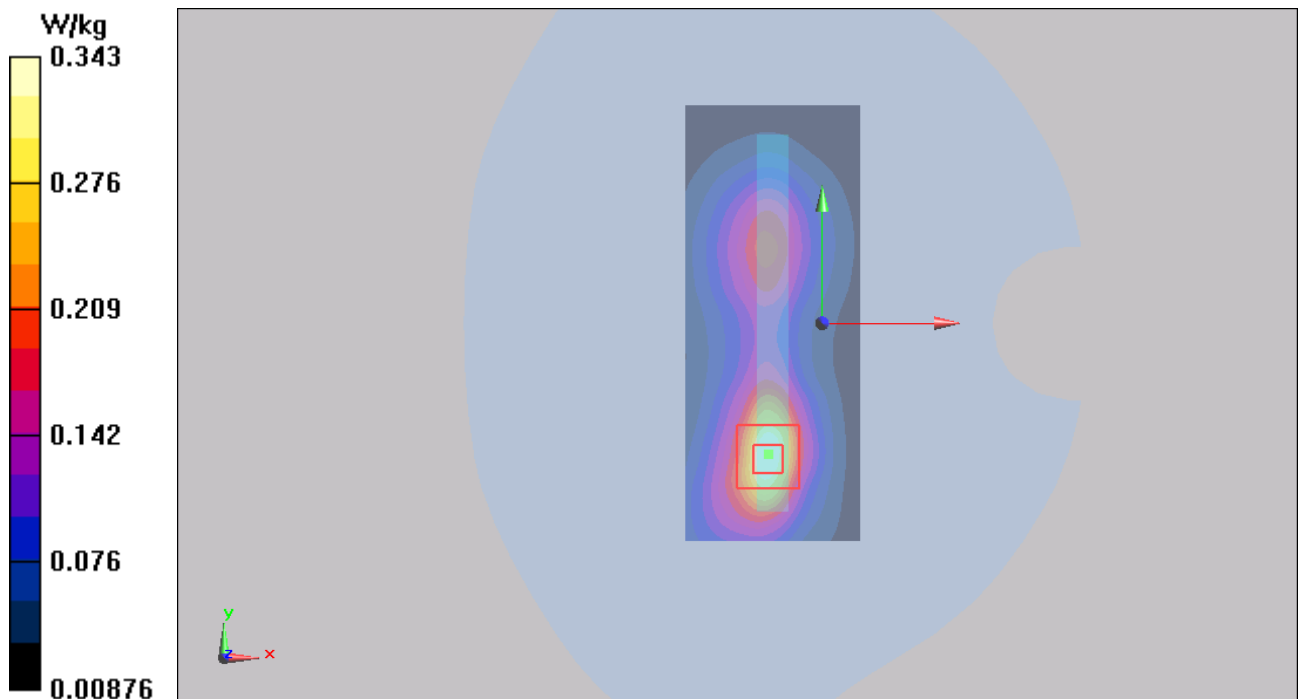

Figure 64 Body, Left Edge, UMTS Band IV Channel 1413

UMTS Band IV Right Edge Middle (Hotspot Open,10mm)

Date/Time: 7/19/2013 4:14:59 PM

Communication System: WCDMA ; Frequency: 1732.6 MHz;Duty Cycle: 1:1

Medium parameters used: $f = 1733$ MHz; $\sigma = 1.454$ mho/m; $\epsilon_r = 52.175$; $\rho = 1000$ kg/m³

Ambient Temperature:22.3 °C Liquid Temperature: 21.5°C

Phantom section: Flat Section

DASY5 Configuration:

Sensor-Surface: 4mm (Mechanical Surface Detection)

Probe: EX3DV4 - SN3753; ConvF(7.82, 7.82, 7.82); Calibrated: 1/17/2013;

Electronics: DAE4 Sn1317; Calibrated: 1/25/2013

Phantom: SAM 2; Type: SAM;

Measurement SW: DASY52, Version 52.8 (2); SEMCAD X Version 14.6.6 (6824)

Right Edge Middle /Area Scan (41x101x1): Interpolated grid: dx=15 mm, dy=15 mm

Maximum value of SAR (interpolated) = 0.202 W/kg

Right Edge Middle /Zoom Scan (5x5x7)/Cube 0: Measurement grid: dx=8mm, dy=8mm, dz=5mm

Reference Value = 8.719 V/m; Power Drift = 0.04 dB

Peak SAR (extrapolated) = 0.285 mW/g

SAR(1 g) = 0.177 mW/g; SAR(10 g) = 0.105 mW/g

Maximum value of SAR (measured) = 0.192 W/kg

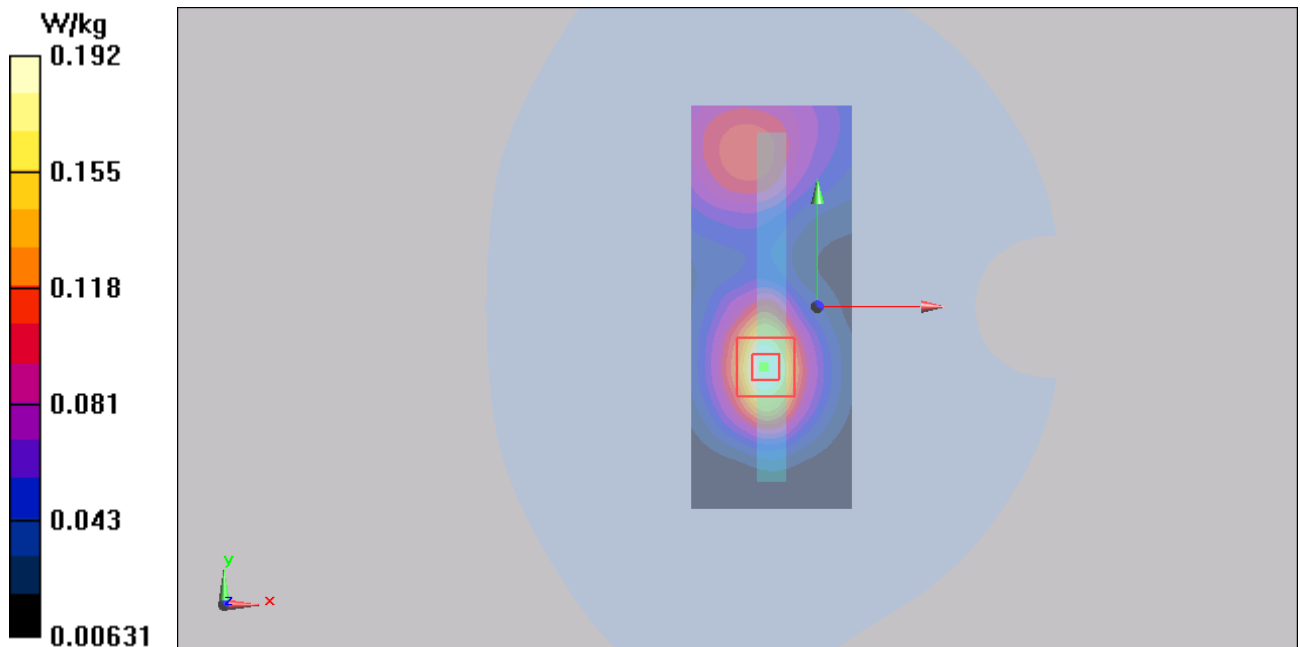

Figure 65 Body, Right Edge, UMTS Band IV Channel 1413

UMTS Band IV Bottom Edge High (Hotspot Open,10mm)

Date/Time: 7/19/2013 4:45:33 PM

Communication System: WCDMA; Frequency: 1752.6 MHz; Duty Cycle: 1:1

Medium parameters used: $f = 1753$ MHz; $\sigma = 1.471$ mho/m; $\epsilon_r = 52.12$; $\rho = 1000$ kg/m³

Ambient Temperature: 22.3 °C Liquid Temperature: 21.5 °C

Phantom section: Flat Section

DASY5 Configuration:

Sensor-Surface: 4mm (Mechanical Surface Detection)

Probe: EX3DV4 - SN3753; ConvF(7.82, 7.82, 7.82); Calibrated: 1/17/2013;

Electronics: DAE4 Sn1317; Calibrated: 1/25/2013

Phantom: SAM 2; Type: SAM;

Measurement SW: DASY52, Version 52.8 (2); SEMCAD X Version 14.6.6 (6824)

Bottom Edge High /Area Scan (41x61x1): Interpolated grid: dx=15 mm, dy=15 mm

Maximum value of SAR (interpolated) = 0.612 W/kg

Bottom Edge High /Zoom Scan (5x5x7)/Cube 0: Measurement grid: dx=8mm, dy=8mm, dz=5mm

Reference Value = 20.375 V/m; Power Drift = 0.07 dB

Peak SAR (extrapolated) = 0.913 mW/g

SAR(1 g) = 0.556 mW/g; SAR(10 g) = 0.329 mW/g

Maximum value of SAR (measured) = 0.605 W/kg

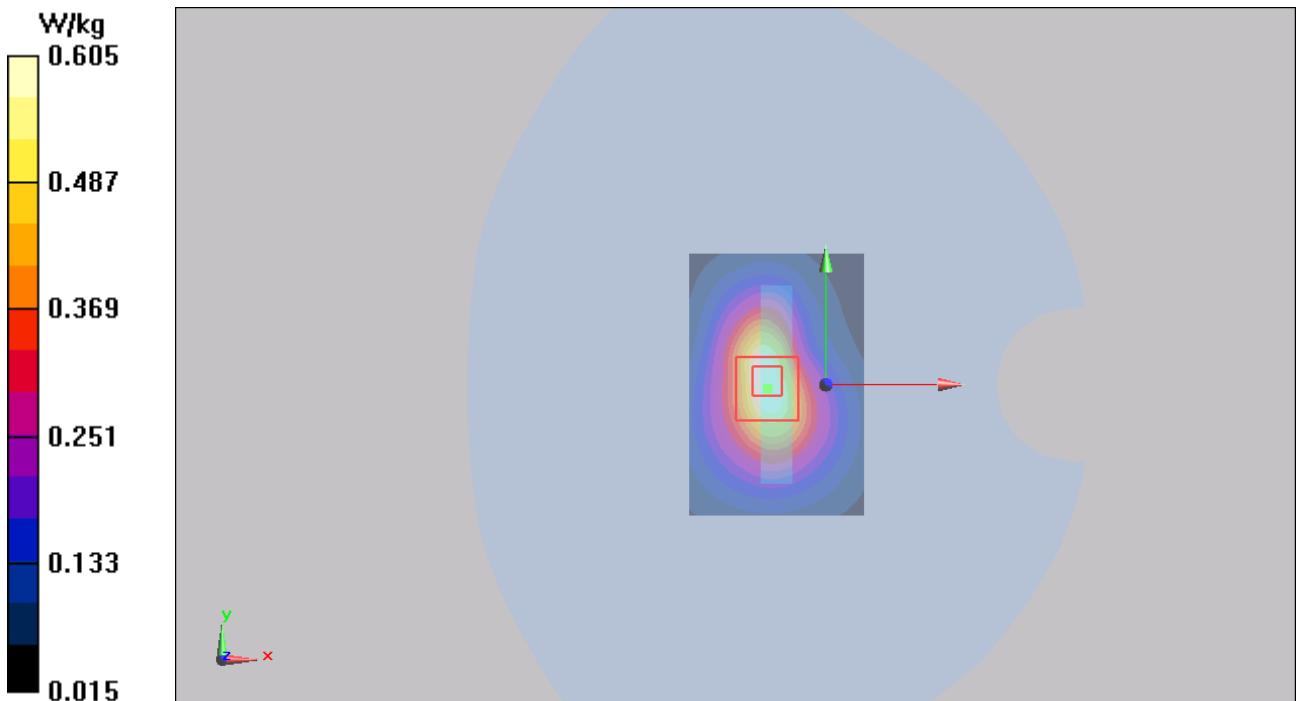

Figure 66 Body, Bottom Edge, UMTS Band IV Channel 1513

UMTS Band IV Bottom Edge Middle (Hotspot Open,10mm)

Date/Time: 7/19/2013 4:32:11 PM

Communication System: WCDMA ; Frequency: 1732.6 MHz;Duty Cycle: 1:1

Medium parameters used: $f = 1733$ MHz; $\sigma = 1.454$ mho/m; $\epsilon_r = 52.175$; $\rho = 1000$ kg/m³

Ambient Temperature:22.3 °C Liquid Temperature: 21.5°C

Phantom section: Flat Section

DASY5 Configuration:

Sensor-Surface: 4mm (Mechanical Surface Detection)

Probe: EX3DV4 - SN3753; ConvF(7.82, 7.82, 7.82); Calibrated: 1/17/2013;

Electronics: DAE4 Sn1317; Calibrated: 1/25/2013

Phantom: SAM 2; Type: SAM;

Measurement SW: DASY52, Version 52.8 (2); SEMCAD X Version 14.6.6 (6824)

Bottom Edge Middle /Area Scan (41x61x1): Interpolated grid: dx=15 mm, dy=15 mm

Maximum value of SAR (interpolated) = 0.793 W/kg

Bottom Edge Middle /Zoom Scan (5x5x7)/Cube 0: Measurement grid: dx=8mm, dy=8mm, dz=5mm

Reference Value = 23.293 V/m; Power Drift = 0.04 dB

Peak SAR (extrapolated) = 1.172 mW/g

SAR(1 g) = 0.717 mW/g; SAR(10 g) = 0.426 mW/g

Maximum value of SAR (measured) = 0.781 W/kg

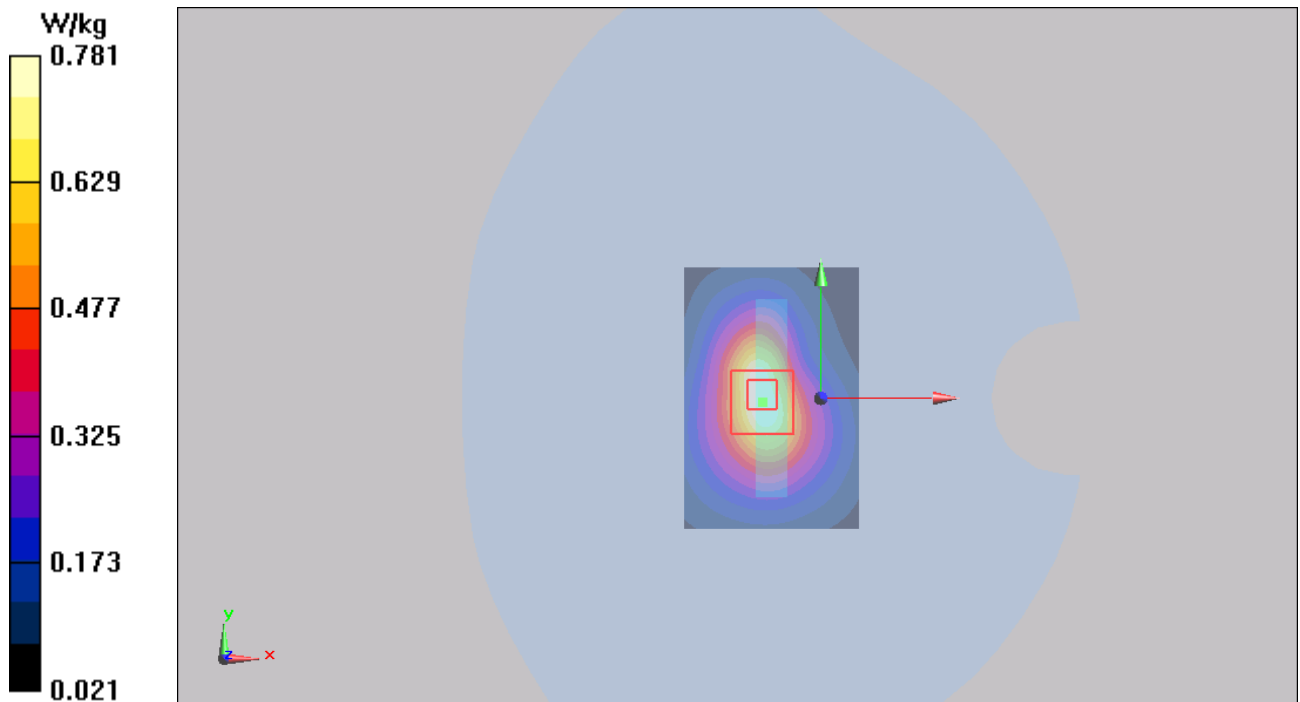

Figure 67 Body, Bottom Edge, UMTS Band IV Channel 1413

UMTS Band IV Bottom Edge Low (Hotspot Open,10mm)

Date/Time: 7/19/2013 4:57:20 PM

Communication System: WCDMA; Frequency: 1712.4 MHz; Duty Cycle: 1:1

Medium parameters used (interpolated): $f = 1712.4$ MHz; $\sigma = 1.443$ mho/m; $\epsilon_r = 52.223$; $\rho = 1000$ kg/m³

Ambient Temperature: 22.3 °C Liquid Temperature: 21.5 °C

Phantom section: Flat Section

DASY5 Configuration:

Sensor-Surface: 4mm (Mechanical Surface Detection)

Probe: EX3DV4 - SN3753; ConvF(7.82, 7.82, 7.82); Calibrated: 1/17/2013;

Electronics: DAE4 Sn1317; Calibrated: 1/25/2013

Phantom: SAM 2; Type: SAM;

Measurement SW: DASY52, Version 52.8 (2); SEMCAD X Version 14.6.6 (6824)

Bottom Edge Low /Area Scan (41x61x1): Interpolated grid: dx=15 mm, dy=15 mm

Maximum value of SAR (interpolated) = 0.635 W/kg

Bottom Edge Low /Zoom Scan (5x5x7)/Cube 0: Measurement grid: dx=8mm, dy=8mm, dz=5mm

Reference Value = 21.024 V/m; Power Drift = 0.10 dB

Peak SAR (extrapolated) = 0.939 mW/g

SAR(1 g) = 0.579 mW/g; SAR(10 g) = 0.345 mW/g

Maximum value of SAR (measured) = 0.629 W/kg

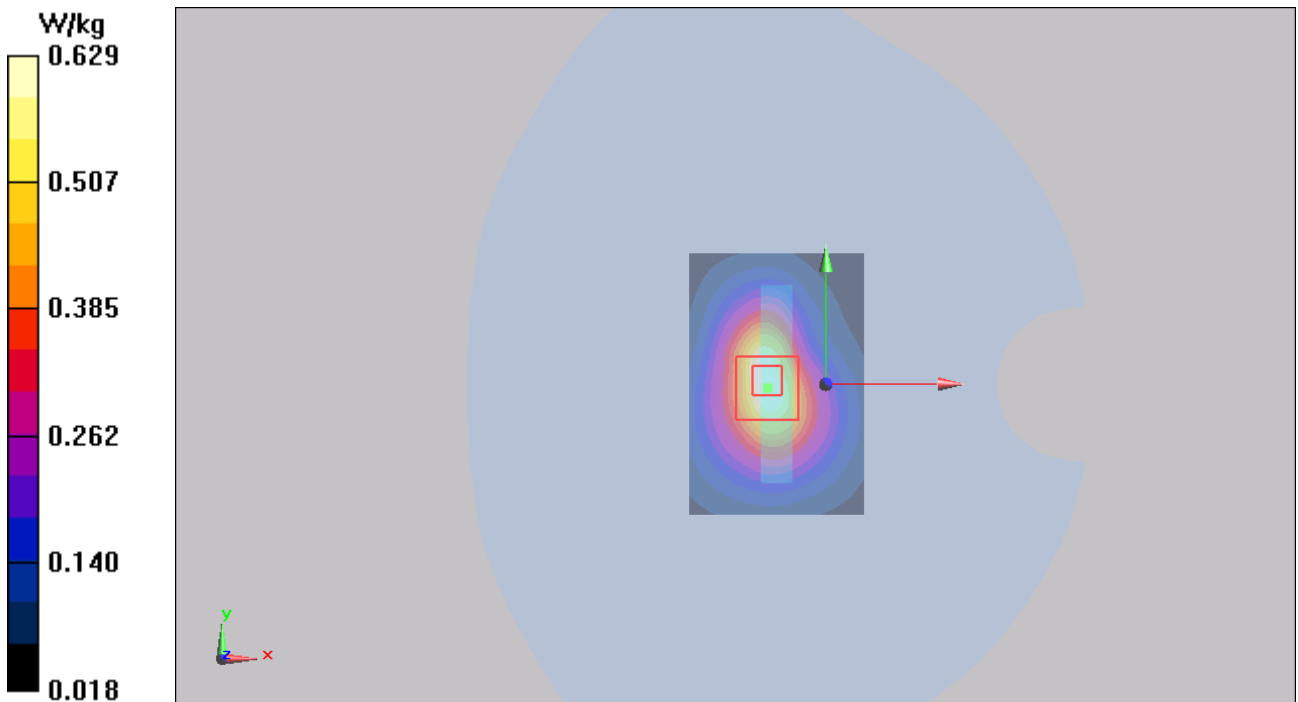

Figure 68 Body, Bottom Edge, UMTS Band IV Channel 1312

TA Technology (Shanghai) Co., Ltd. Test Report

Report No.: RXA1307-0093SAR01R3

Page 135 of 225

UMTS Band IV Back Side Middle (1st Repeated, Hotspot Open,10mm)

Date/Time: 7/19/2013 1:11:45 PM

Communication System: WCDMA ; Frequency: 1732.6 MHz;Duty Cycle: 1:1

Medium parameters used: $f = 1733$ MHz; $\sigma = 1.454$ mho/m; $\epsilon_r = 52.175$; $\rho = 1000$ kg/m³

Ambient Temperature:22.3 °C Liquid Temperature: 21.5°C

Phantom section: Flat Section

DASY5 Configuration:

Sensor-Surface: 4mm (Mechanical Surface Detection)

Probe: EX3DV4 - SN3753; ConvF(7.82, 7.82, 7.82); Calibrated: 1/17/2013;

Electronics: DAE4 Sn1317; Calibrated: 1/25/2013

Phantom: SAM 2; Type: SAM;

Measurement SW: DASY52, Version 52.8 (2); SEMCAD X Version 14.6.6 (6824)

Back Side Middle /Area Scan (61x101x1): Interpolated grid: dx=15 mm, dy=15 mm

Maximum value of SAR (interpolated) = 1.05 W/kg

Back Side Middle /Zoom Scan (5x5x7)/Cube 0: Measurement grid: dx=8mm, dy=8mm, dz=5mm

Reference Value = 12.151 V/m; Power Drift = -0.08 dB

Peak SAR (extrapolated) = 1.529 mW/g

SAR(1 g) = 0.938 mW/g; SAR(10 g) = 0.587 mW/g

Maximum value of SAR (measured) = 1.03 W/kg

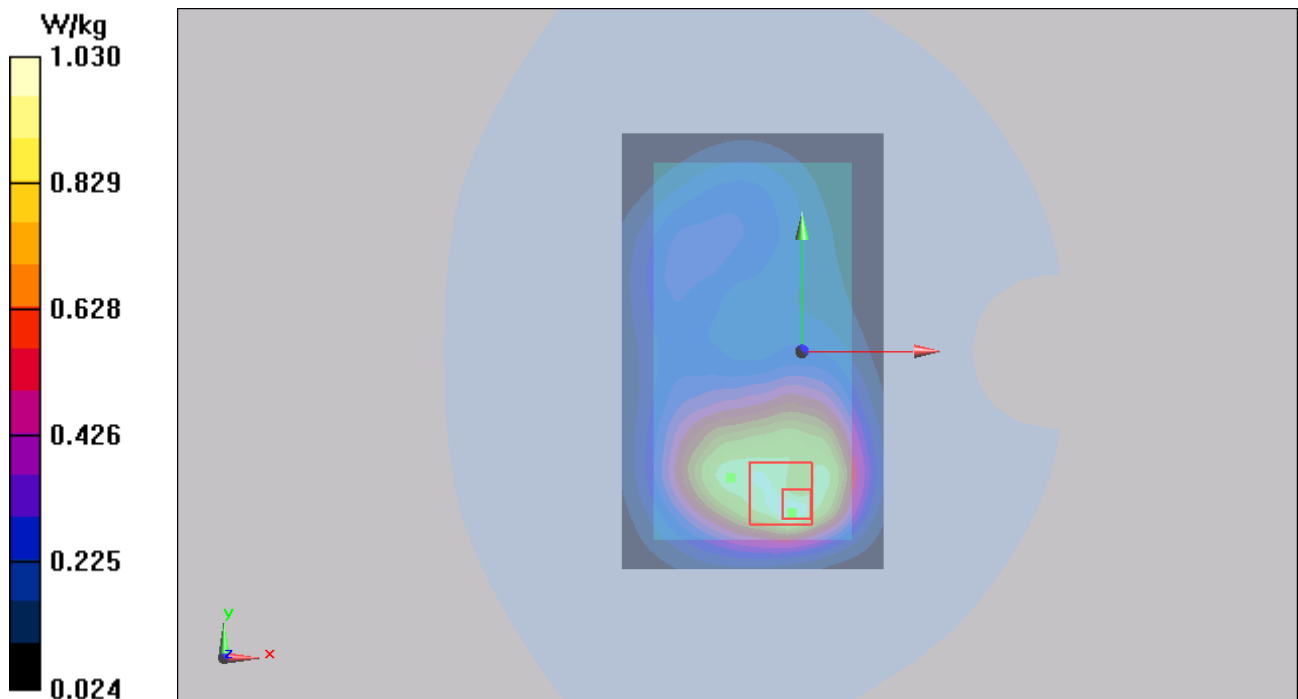

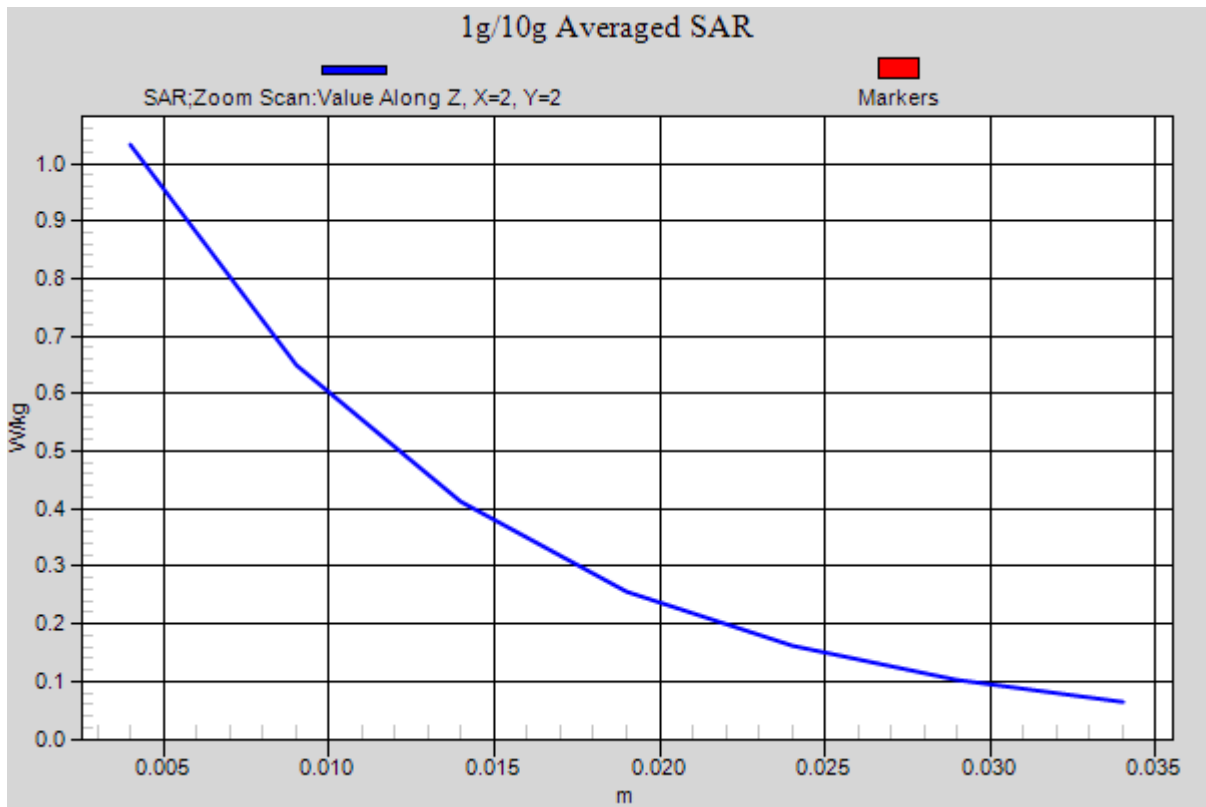

Figure 69 Body, Back Side, UMTS Band IV Channel 1413

TA Technology (Shanghai) Co., Ltd.

Test Report

Report No.: RXA1307-0093SAR01R3

Page 137 of 225

UMTS Band V Left Cheek Middle

Date/Time: 7/20/2013 4:33:32 PM

Communication System: WCDMA; Frequency: 836.6 MHz; Duty Cycle: 1:1

Medium parameters used: $f = 837$ MHz; $\sigma = 0.918$ mho/m; $\epsilon_r = 41.233$; $\rho = 1000$ kg/m³

Ambient Temperature: 22.3 °C Liquid Temperature: 21.5 °C

Phantom section: Left Section

DASY5 Configuration:

Sensor-Surface: 4mm (Mechanical Surface Detection)

Probe: EX3DV4 - SN3753; ConvF(8.95, 8.95, 8.95); Calibrated: 1/17/2013 ;

Electronics: DAE4 Sn1317; Calibrated: 1/25/2013

Phantom: SAM1; Type: SAM; Serial: TP-1534

Measurement SW: DASY52, Version 52.8 (2); SEMCAD X Version 14.6.6 (6824)

Left Cheek Middle /Area Scan (61x111x1): Interpolated grid: dx=15 mm, dy=15 mm

Maximum value of SAR (interpolated) = 0.00625 W/kg

Left Cheek Middle /Zoom Scan (5x5x7)/Cube 0: Measurement grid: dx=8mm, dy=8mm, dz=5mm

Reference Value = 0.795 V/m; Power Drift = 0.028 dB

Peak SAR (extrapolated) = 0.00705 mW/g

SAR(1 g) = 0.0060 mW/g; SAR(10 g) = 0.00408 mW/g

Maximum value of SAR (measured) = 0.00660 W/kg

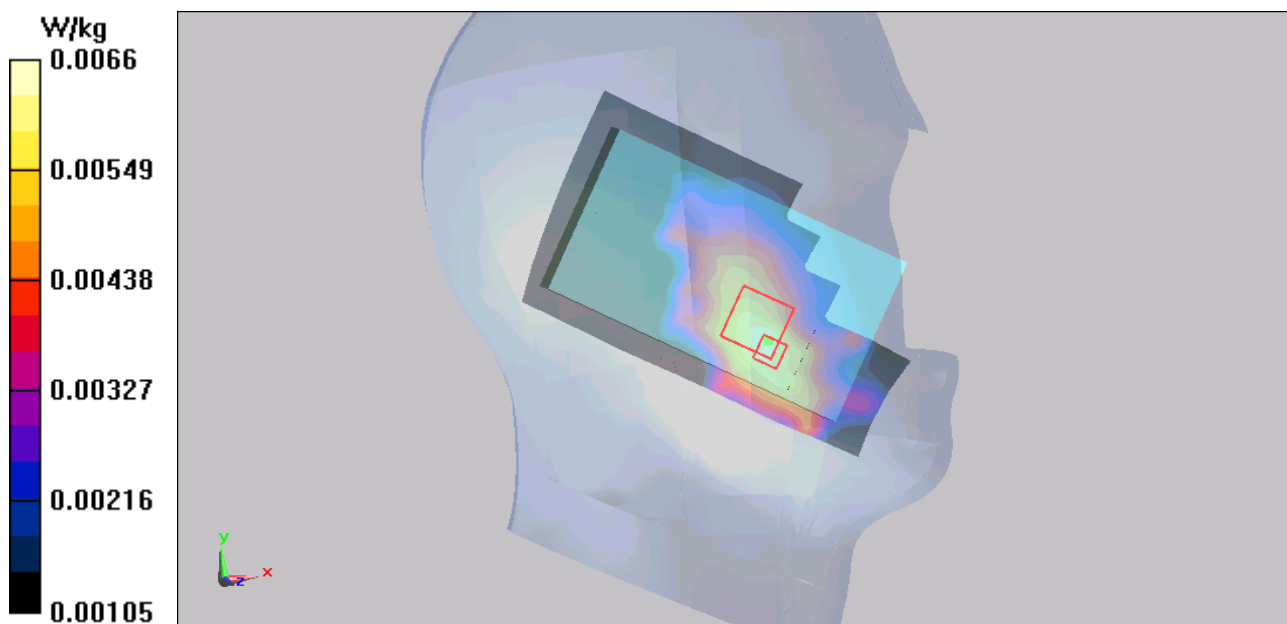

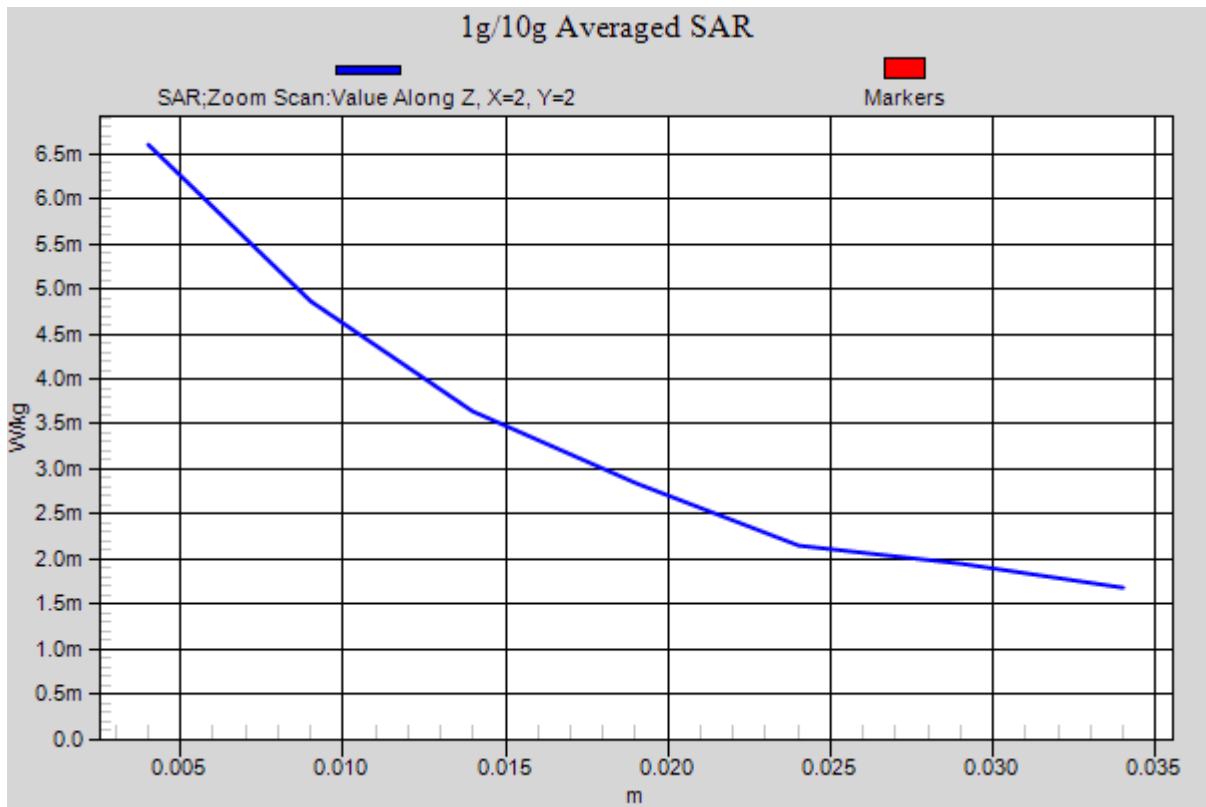

Figure 70 Left Hand Touch Cheek UMTS Band V Channel 4183

TA Technology (Shanghai) Co., Ltd.
Test Report

UMTS Band V Left Tilt Middle

Date/Time: 7/20/2013 4:09:40 PM

Communication System: WCDMA; Frequency: 836.6 MHz; Duty Cycle: 1:1

Medium parameters used: $f = 837$ MHz; $\sigma = 0.918$ mho/m; $\epsilon_r = 41.233$; $\rho = 1000$ kg/m³

Ambient Temperature: 22.3 °C Liquid Temperature: 21.5 °C

Phantom section: Left Section

DASY5 Configuration:

Sensor-Surface: 4mm (Mechanical Surface Detection)

Probe: EX3DV4 - SN3753; ConvF(8.95, 8.95, 8.95); Calibrated: 1/17/2013 ;

Electronics: DAE4 Sn1317; Calibrated: 1/25/2013

Phantom: SAM1; Type: SAM; Serial: TP-1534

Measurement SW: DASY52, Version 52.8 (2); SEMCAD X Version 14.6.6 (6824)

Left Tilt Middle /Area Scan (61x111x1): Interpolated grid: dx=15 mm, dy=15 mm

Maximum value of SAR (interpolated) = 0.00365 W/kg

Left Tilt Middle /Zoom Scan (5x5x7)/Cube 0: Measurement grid: dx=8mm, dy=8mm, dz=5mm

Reference Value = 1.435 V/m; Power Drift = 0.085 dB

Peak SAR (extrapolated) = 0.00355 mW/g

SAR(1 g) = 0.0025 mW/g; SAR(10 g) = 0.0019 mW/g

Maximum value of SAR (measured) = 0.00267 W/kg

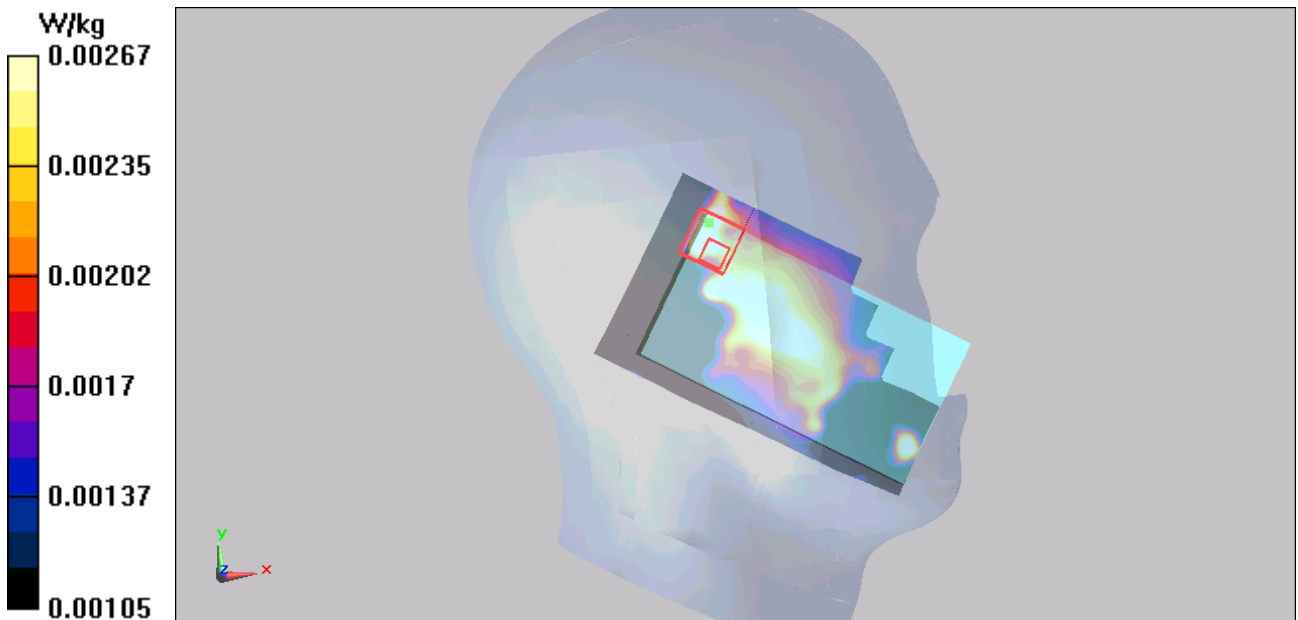

Figure 71 Left Hand Tilt 15° UMTS Band V Channel 4183

UMTS Band V Right Cheek Middle

Date/Time: 7/20/2013 3:45:08 PM

Communication System: WCDMA; Frequency: 836.6 MHz; Duty Cycle: 1:1

Medium parameters used: $f = 837$ MHz; $\sigma = 0.918$ mho/m; $\epsilon_r = 41.233$; $\rho = 1000$ kg/m³

Ambient Temperature: 22.3 °C Liquid Temperature: 21.5 °C

Phantom section: Right Section

DASY5 Configuration:

Sensor-Surface: 4mm (Mechanical Surface Detection)

Probe: EX3DV4 - SN3753; ConvF(8.95, 8.95, 8.95); Calibrated: 1/17/2013 ;

Electronics: DAE4 Sn1317; Calibrated: 1/25/2013

Phantom: SAM1; Type: SAM; Serial: TP-1534

Measurement SW: DASY52, Version 52.8 (2); SEMCAD X Version 14.6.6 (6824)

Right Cheek Middle /Area Scan (61x111x1): Interpolated grid: dx=15 mm, dy=15 mm

Maximum value of SAR (interpolated) = 0.0123 W/kg

Right Cheek Middle /Zoom Scan (5x5x7)/Cube 0: Measurement grid: dx=8mm, dy=8mm, dz=5mm

Reference Value = 0.514 V/m; Power Drift = 0.088 dB

Peak SAR (extrapolated) = 0.00663 mW/g

SAR(1 g) = 0.0054 mW/g; SAR(10 g) = 0.0042 mW/g

Maximum value of SAR (measured) = 0.00565 W/kg

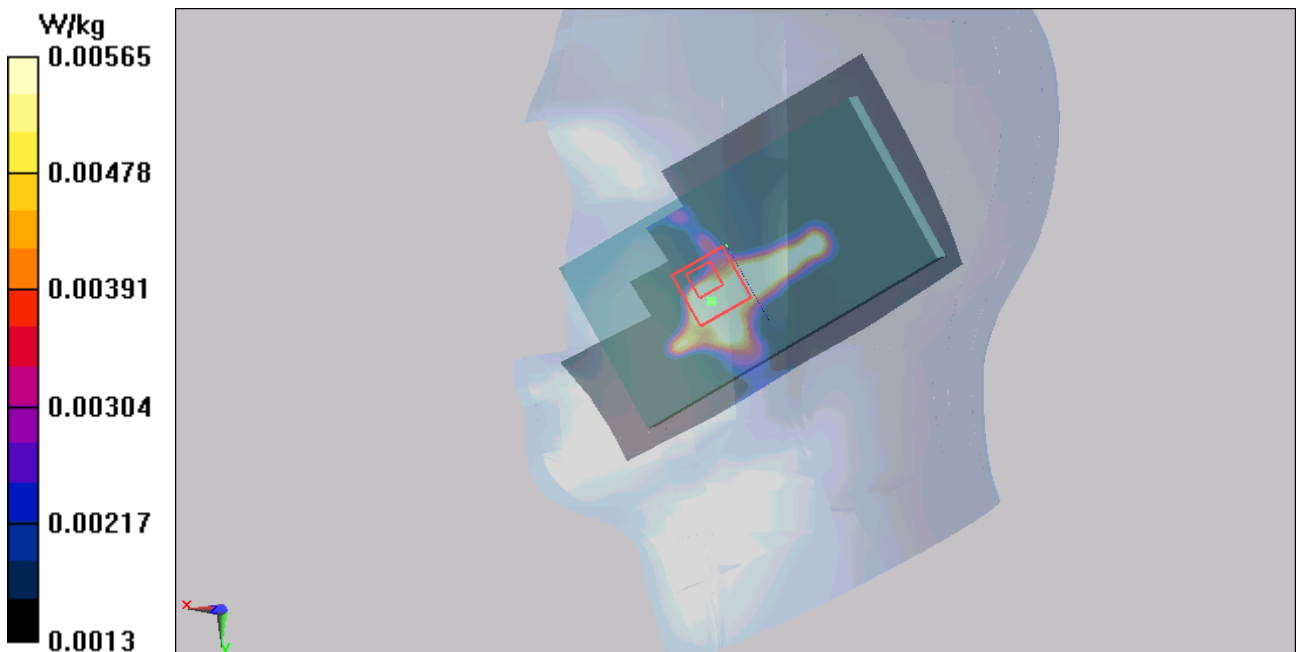

Figure 72 Right Hand Touch Cheek UMTS Band V Channel 4183

UMTS Band V Right Tilt Middle

Date/Time: 7/20/2013 3:15:38 PM

Communication System: WCDMA; Frequency: 836.6 MHz; Duty Cycle: 1:1

Medium parameters used: $f = 837$ MHz; $\sigma = 0.918$ mho/m; $\epsilon_r = 41.233$; $\rho = 1000$ kg/m³

Ambient Temperature: 22.3 °C Liquid Temperature: 21.5 °C

Phantom section: Right Section

DASY5 Configuration:

Sensor-Surface: 4mm (Mechanical Surface Detection)

Probe: EX3DV4 - SN3753; ConvF(8.95, 8.95, 8.95); Calibrated: 1/17/2013 ;

Electronics: DAE4 Sn1317; Calibrated: 1/25/2013

Phantom: SAM1; Type: SAM; Serial: TP-1534

Measurement SW: DASY52, Version 52.8 (2); SEMCAD X Version 14.6.6 (6824)

Right Tilt Middle /Area Scan (61x111x1): Interpolated grid: dx=15 mm, dy=15 mm

Maximum value of SAR (interpolated) = 0.00343 W/kg

Right Tilt Middle /Zoom Scan (5x5x7)/Cube 0: Measurement grid: dx=8mm, dy=8mm, dz=5mm

Reference Value = 1.669 V/m; Power Drift = 0.038 dB

Peak SAR (extrapolated) = 0.00455 mW/g

SAR(1 g) = 0.0023 mW/g; SAR(10 g) = 0.00129 mW/g

Maximum value of SAR (measured) = 0.00272 W/kg

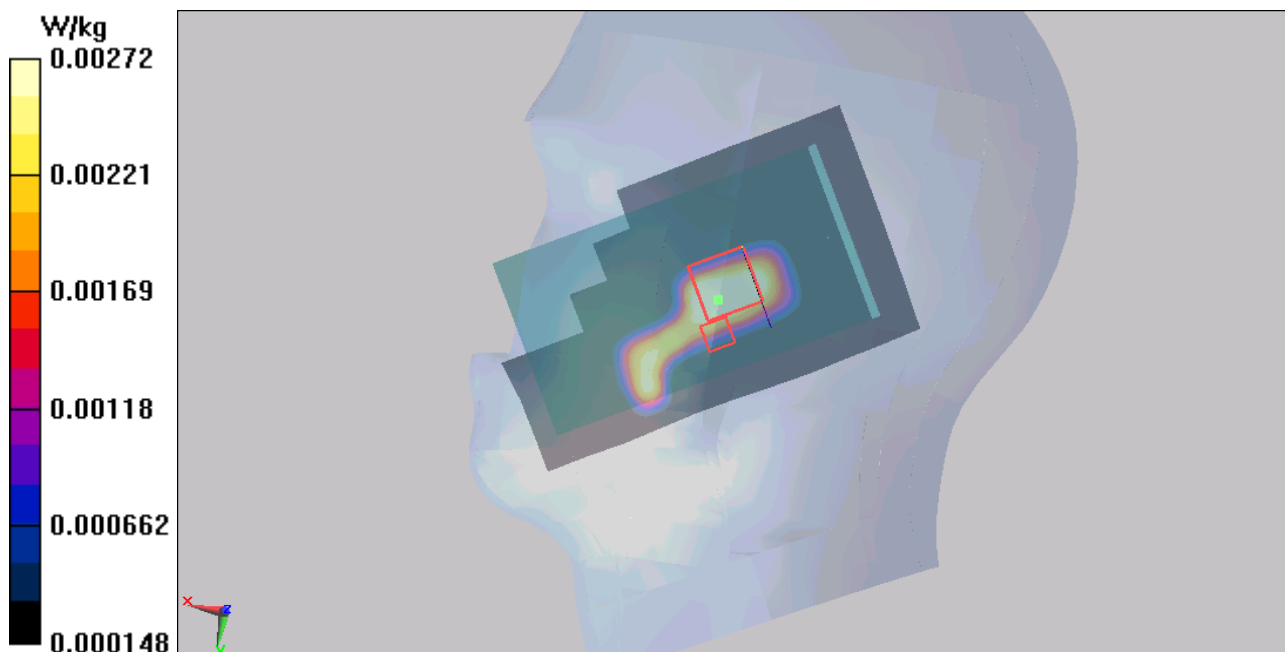

Figure 73 Right Hand Tilt 15° UMTS Band V Channel 4183

TA Technology (Shanghai) Co., Ltd.

Test Report

Report No.: RXA1307-0093SAR01R3

Page 142 of 225

UMTS Band V Back Side Middle

Date/Time: 7/20/2013 12:57:48 PM

Communication System: WCDMA; Frequency: 836.6 MHz; Duty Cycle: 1:1

Medium parameters used: $f = 837$ MHz; $\sigma = 1.014$ mho/m; $\epsilon_r = 54.339$; $\rho = 1000$ kg/m³

Ambient Temperature: 22.3 °C Liquid Temperature: 21.5 °C

Phantom section: Flat Section

DASY5 Configuration:

Sensor-Surface: 4mm (Mechanical Surface Detection)

Probe: EX3DV4 - SN3753; ConvF(9.05, 9.05, 9.05); Calibrated: 1/17/2013;

Electronics: DAE4 Sn1317; Calibrated: 1/25/2013

Phantom: SAM1; Type: SAM; Serial: TP-1534

Measurement SW: DASY52, Version 52.8 (2); SEMCAD X Version 14.6.6 (6824)

Back Side Middle /Area Scan (61x101x1): Interpolated grid: dx=15 mm, dy=15 mm

Maximum value of SAR (interpolated) = 0.0332 W/kg

Back Side Middle /Zoom Scan (5x5x7)/Cube 0: Measurement grid: dx=8mm, dy=8mm, dz=5mm

Reference Value = 4.919 V/m; Power Drift = 0.10 dB

Peak SAR (extrapolated) = 0.045 mW/g

SAR(1 g) = 0.0314 mW/g; SAR(10 g) = 0.022 mW/g

Maximum value of SAR (measured) = 0.0336 W/kg

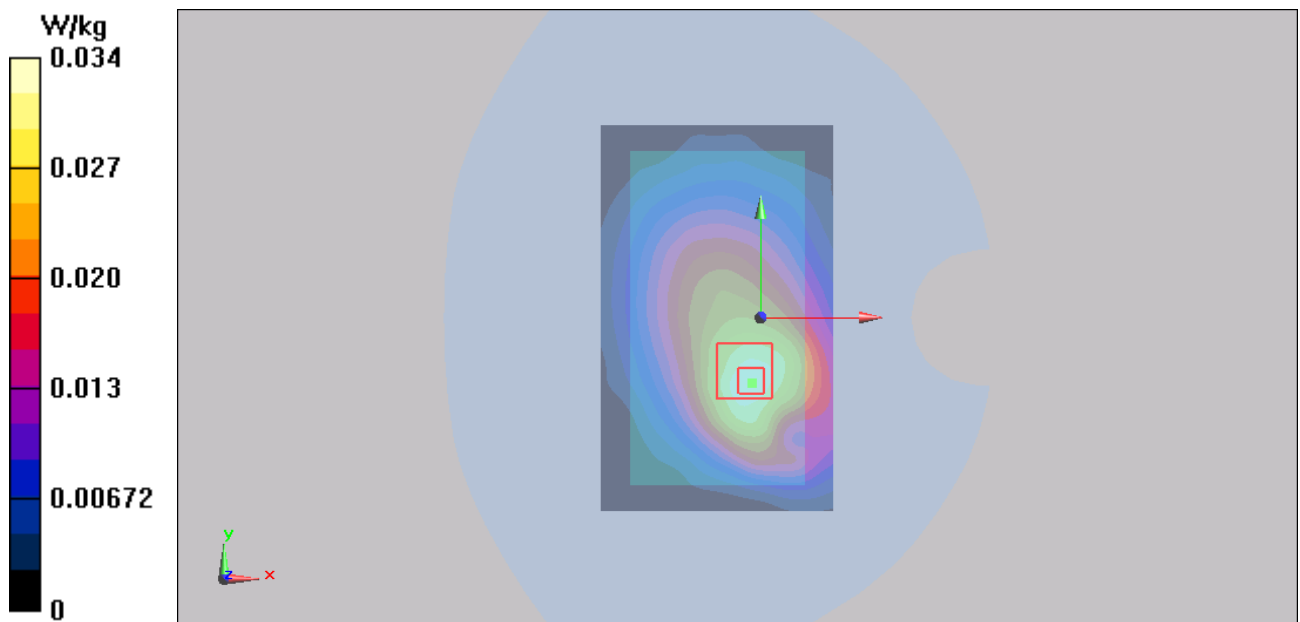

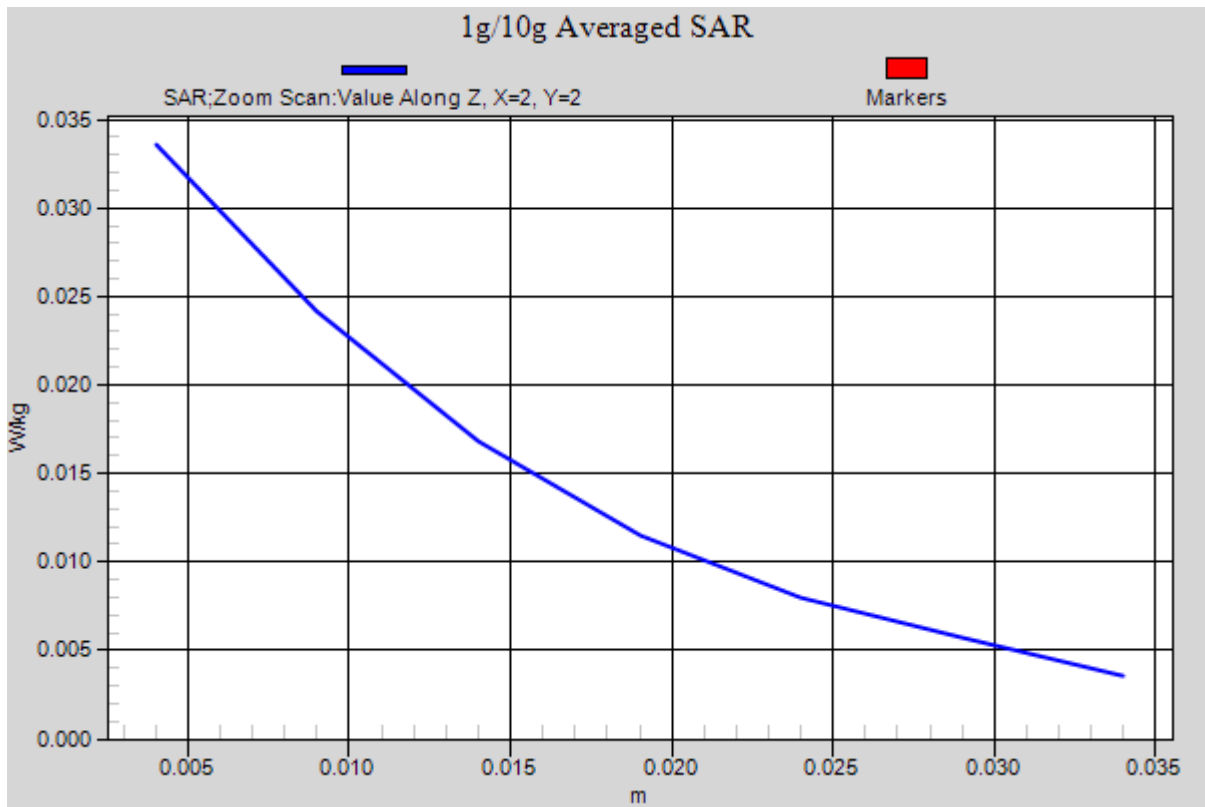

Figure 74 Body, Back Side, UMTS Band V Channel 4183

TA Technology (Shanghai) Co., Ltd.
Test Report

Report No.: RXA1307-0093SAR01R3

Page 144 of 225

UMTS Band V Front Side Middle

Date/Time: 7/20/2013 12:40:08 PM

Communication System: WCDMA; Frequency: 836.6 MHz; Duty Cycle: 1:1

Medium parameters used: $f = 837$ MHz; $\sigma = 1.014$ mho/m; $\epsilon_r = 54.339$; $\rho = 1000$ kg/m³

Ambient Temperature: 22.3 °C Liquid Temperature: 21.5 °C

Phantom section: Flat Section

DASY5 Configuration:

Sensor-Surface: 4mm (Mechanical Surface Detection)

Probe: EX3DV4 - SN3753; ConvF(9.05, 9.05, 9.05); Calibrated: 1/17/2013;

Electronics: DAE4 Sn1317; Calibrated: 1/25/2013

Phantom: SAM1; Type: SAM; Serial: TP-1534

Measurement SW: DASY52, Version 52.8 (2); SEMCAD X Version 14.6.6 (6824)

Front Side Middle /Area Scan (61x101x1): Interpolated grid: dx=15 mm, dy=15 mm

Maximum value of SAR (interpolated) = 0.0168 W/kg

Front Side Middle /Zoom Scan (5x5x7)/Cube 0: Measurement grid: dx=8mm, dy=8mm, dz=5mm

Reference Value = 2.686 V/m; Power Drift = 0.083 dB

Peak SAR (extrapolated) = 0.028 mW/g

SAR(1 g) = 0.0163mW/g; SAR(10 g) = 0.010 mW/g

Maximum value of SAR (measured) = 0.0172 W/kg

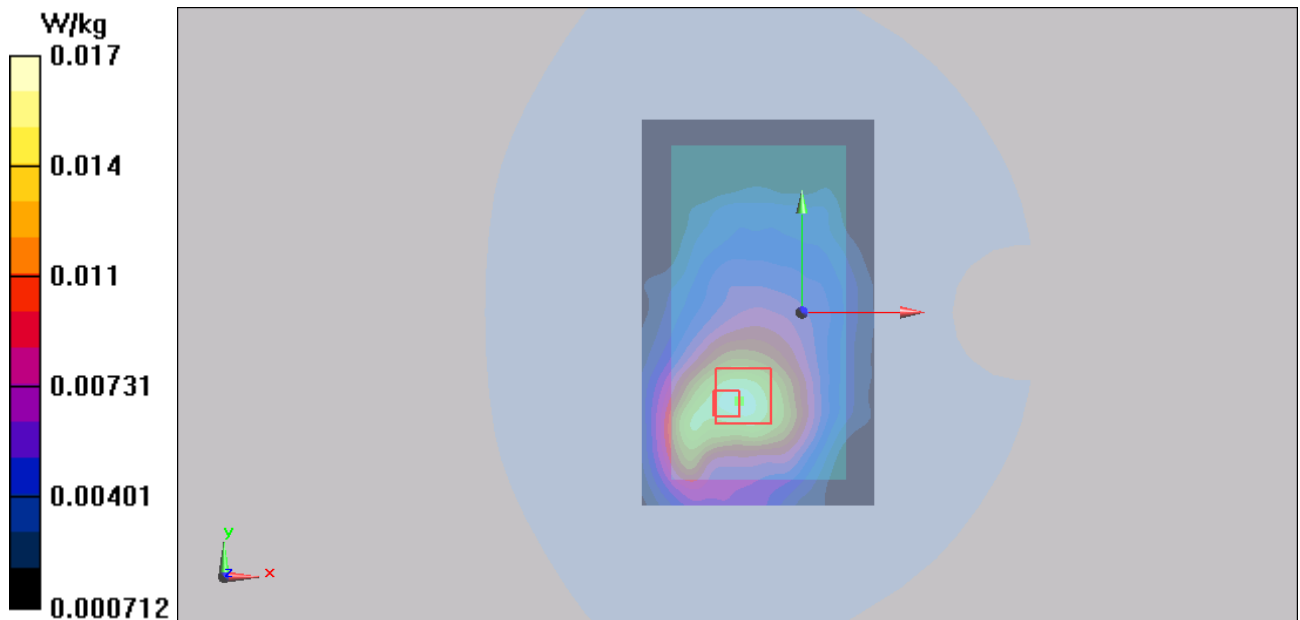

Figure 75 Body, Front Side, UMTS Band V Channel 4183

TA Technology (Shanghai) Co., Ltd. Test Report

Report No.: RXA1307-0093SAR01R3

Page 145 of 225

UMTS Band V Left Edge Middle

Date/Time: 7/20/2013 12:21:09 PM

Communication System: WCDMA; Frequency: 836.6 MHz; Duty Cycle: 1:1

Medium parameters used: $f = 837$ MHz; $\sigma = 1.014$ mho/m; $\epsilon_r = 54.339$; $\rho = 1000$ kg/m³

Ambient Temperature: 22.3 °C Liquid Temperature: 21.5 °C

Phantom section: Flat Section

DASY5 Configuration:

Sensor-Surface: 4mm (Mechanical Surface Detection)

Probe: EX3DV4 - SN3753; ConvF(9.05, 9.05, 9.05); Calibrated: 1/17/2013;

Electronics: DAE4 Sn1317; Calibrated: 1/25/2013

Phantom: SAM1; Type: SAM; Serial: TP-1534

Measurement SW: DASY52, Version 52.8 (2); SEMCAD X Version 14.6.6 (6824)

Left Edge Middle /Area Scan (31x11x1): Interpolated grid: dx=15 mm, dy=15 mm

Maximum value of SAR (interpolated) = 0.0102 W/kg

Left Edge Middle /Zoom Scan (5x5x7)/Cube 0: Measurement grid: dx=8mm, dy=8mm, dz=5mm

Reference Value = 1.668 V/m; Power Drift = 0.095 dB

Peak SAR (extrapolated) = 0.00764 mW/g

SAR(1 g) = 0.0050 mW/g; SAR(10 g) = 0.0028 mW/g

Maximum value of SAR (measured) = 0.00593 W/kg

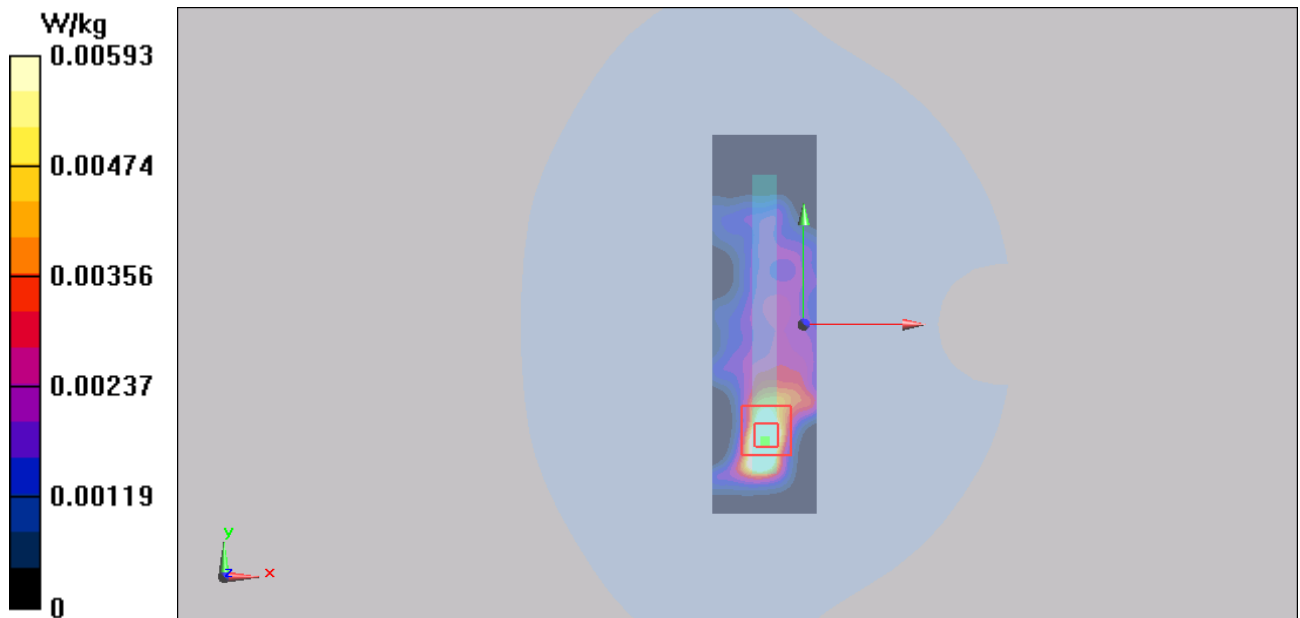

Figure 76 Body, Left Edge, UMTS Band V Channel 4183

TA Technology (Shanghai) Co., Ltd.

Test Report

Report No.: RXA1307-0093SAR01R3

Page 146 of 225

UMTS Band V Right Edge Middle

Date/Time: 7/20/2013 11:39:11 AM

Communication System: WCDMA; Frequency: 836.6 MHz; Duty Cycle: 1:1

Medium parameters used: $f = 837$ MHz; $\sigma = 1.014$ mho/m; $\epsilon_r = 54.339$; $\rho = 1000$ kg/m³

Ambient Temperature: 22.3 °C Liquid Temperature: 21.5 °C

Phantom section: Flat Section

DASY5 Configuration:

Sensor-Surface: 4mm (Mechanical Surface Detection)

Probe: EX3DV4 - SN3753; ConvF(9.05, 9.05, 9.05); Calibrated: 1/17/2013;

Electronics: DAE4 Sn1317; Calibrated: 1/25/2013

Phantom: SAM1; Type: SAM; Serial: TP-1534

Measurement SW: DASY52, Version 52.8 (2); SEMCAD X Version 14.6.6 (6824)

Right Edge Middle /Area Scan (31x111x1): Interpolated grid: dx=15 mm, dy=15 mm

Maximum value of SAR (interpolated) = 0.00571 W/kg

Right Edge Middle /Zoom Scan (5x5x7)/Cube 0: Measurement grid: dx=8mm, dy=8mm, dz=5mm

Reference Value = 2.262 V/m; Power Drift = 0.058 dB

Peak SAR (extrapolated) = 0.00799 mW/g

SAR(1 g) = 0.0050 mW/g; SAR(10 g) = 0.00315 mW/g

Maximum value of SAR (measured) = 0.00532 W/kg

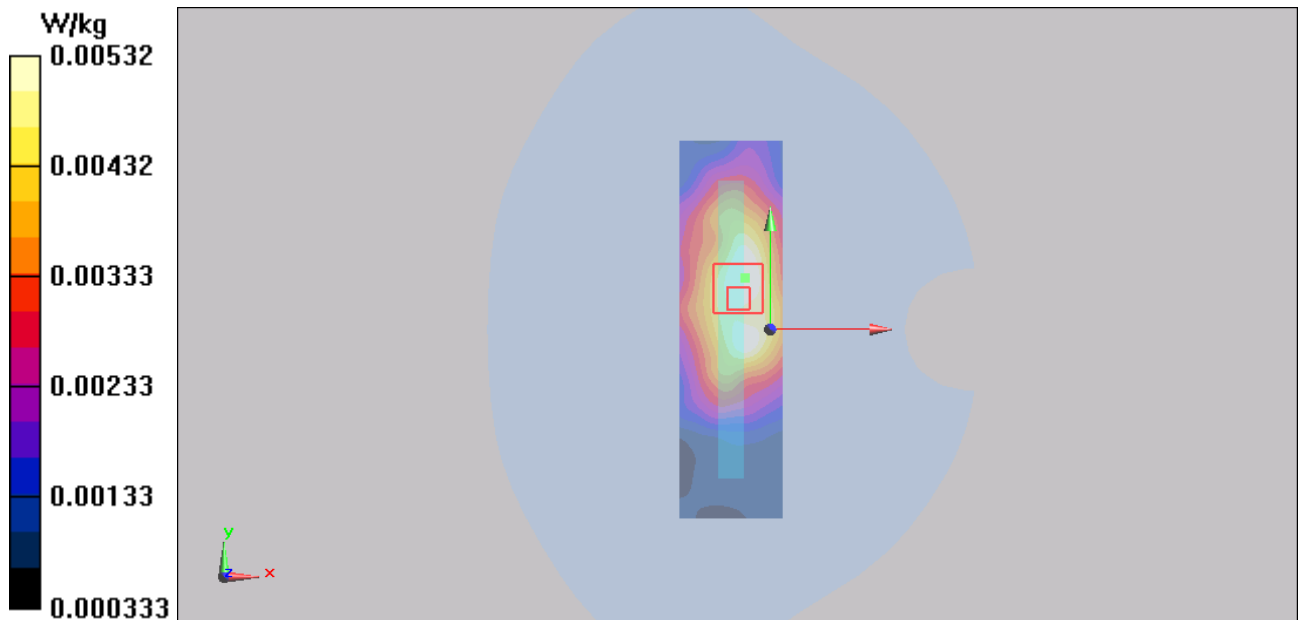

Figure 77 Body, Right Edge, UMTS Band V Channel 4183

TA Technology (Shanghai) Co., Ltd. Test Report

Report No.: RXA1307-0093SAR01R3

Page 147 of 225

UMTS Band V Bottom Edge Middle

Date/Time: 7/20/2013 11:23:41 AM

Communication System: WCDMA; Frequency: 836.6 MHz; Duty Cycle: 1:1

Medium parameters used: $f = 837$ MHz; $\sigma = 1.014$ mho/m; $\epsilon_r = 54.339$; $\rho = 1000$ kg/m³

Ambient Temperature: 22.3 °C Liquid Temperature: 21.5 °C

Phantom section: Flat Section

DASY5 Configuration:

Sensor-Surface: 4mm (Mechanical Surface Detection)

Probe: EX3DV4 - SN3753; ConvF(9.05, 9.05, 9.05); Calibrated: 1/17/2013;

Electronics: DAE4 Sn1317; Calibrated: 1/25/2013

Phantom: SAM1; Type: SAM; Serial: TP-1534

Measurement SW: DASY52, Version 52.8 (2); SEMCAD X Version 14.6.6 (6824)

Bottom Edge Middle /Area Scan (31x61x1): Interpolated grid: dx=15 mm, dy=15 mm

Maximum value of SAR (interpolated) = 0.0122 W/kg

Bottom Edge Middle /Zoom Scan (5x5x7)/Cube 0: Measurement grid: dx=8mm, dy=8mm, dz=5mm

Reference Value = 2.708 V/m; Power Drift = 0.075 dB

Peak SAR (extrapolated) = 0.020 mW/g

SAR(1 g) = 0.010 mW/g; SAR(10 g) = 0.00496 mW/g

Maximum value of SAR (measured) = 0.0110 W/kg

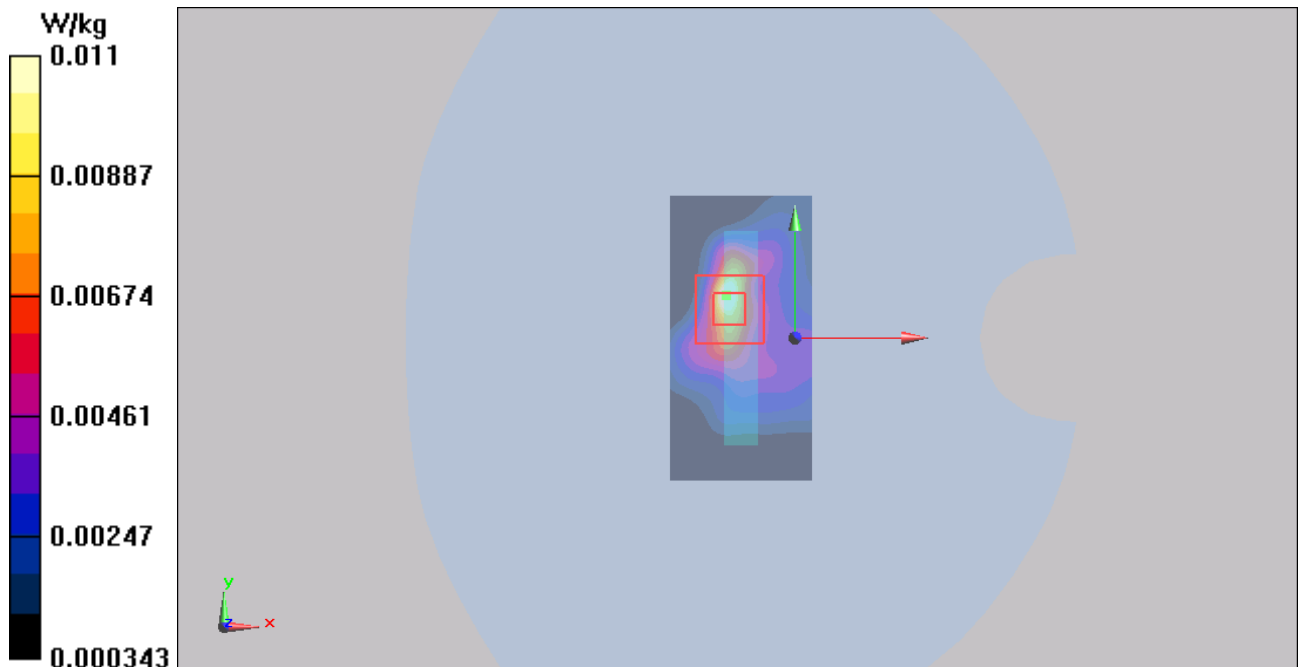

Figure 78 Body, Bottom Edge, UMTS Band V Channel 4183

TA Technology (Shanghai) Co., Ltd.

Test Report

Report No.: RXA1307-0093SAR01R3

Page 148 of 225

802.11b Left Cheek Middle

Date/Time: 7/17/2013 9:24:51 AM

Communication System: 802.11b; Frequency: 2437 MHz; Duty Cycle: 1:1

Medium parameters used (interpolated): $f = 2437$ MHz; $\sigma = 1.865$ mho/m; $\epsilon_r = 38.323$; $\rho = 1000$ kg/m³

Ambient Temperature: 22.3 °C Liquid Temperature: 21.5 °C

Phantom section: Left Section

DASY5 Configuration:

Sensor-Surface: 4mm (Mechanical Surface Detection)

Probe: EX3DV4 - SN3753; ConvF(6.86, 6.86, 6.86); Calibrated: 1/17/2013;

Electronics: DAE4 Sn1317; Calibrated: 1/25/2013

Phantom: SAM 2; Type: SAM;

Measurement SW: DASY52, Version 52.8 (2); SEMCAD X Version 14.6.6 (6824)

Left Cheek Middle /Area Scan (7x12x1): Measurement grid: dx=12 mm, dy=12 mm

Maximum value of SAR (measured) = 0.758 W/kg

Left Cheek Middle /Zoom Scan (7x7x7)/Cube 0: Measurement grid: dx=5mm, dy=5mm, dz=5mm

Reference Value = 11.590 V/m; Power Drift = 0.01 dB

Peak SAR (extrapolated) = 1.391 mW/g

SAR(1 g) = 0.662 mW/g; SAR(10 g) = 0.339 mW/g

Maximum value of SAR (measured) = 0.672 W/kg

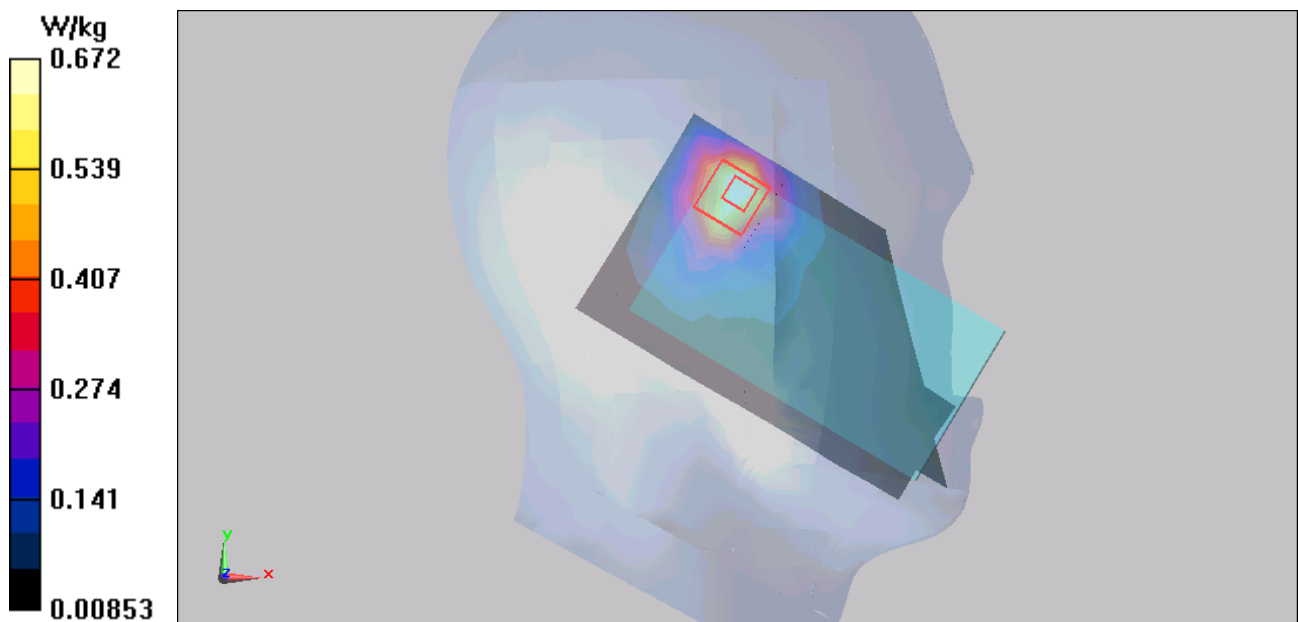

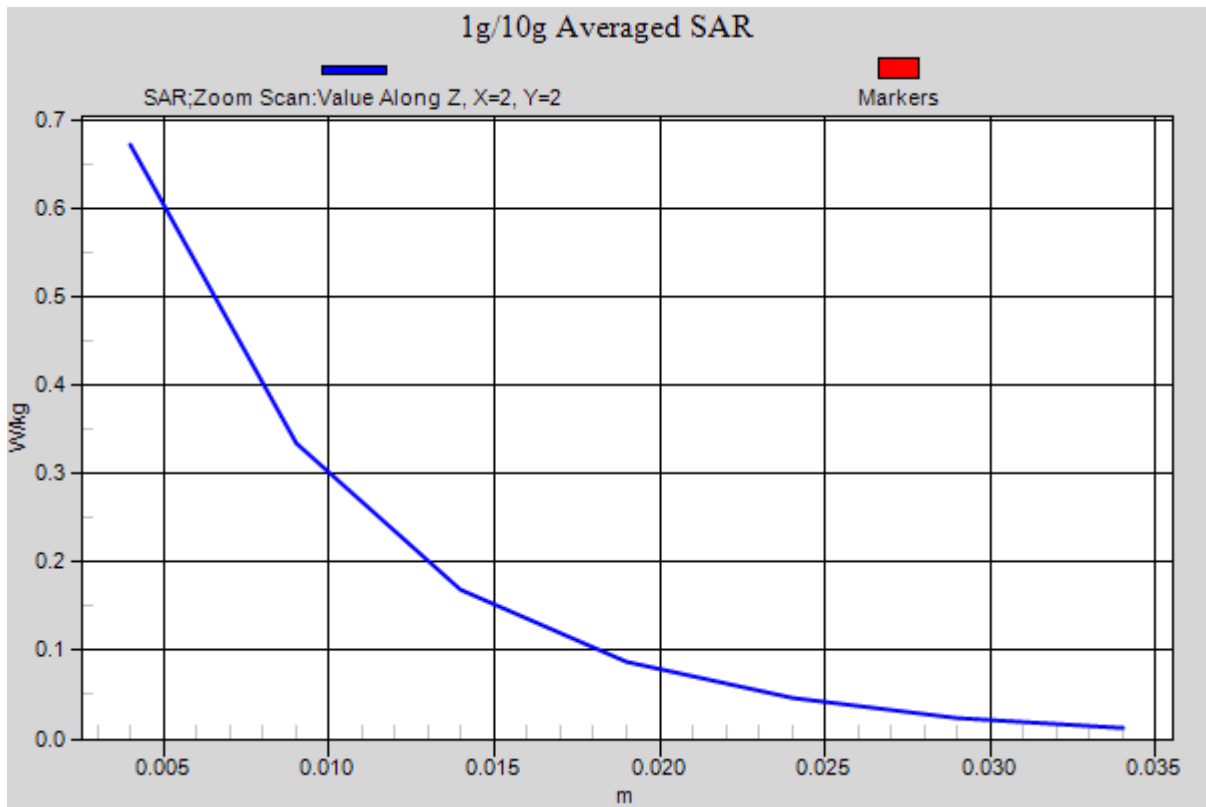

Figure 79 Left Hand Touch Cheek 802.11b Channel 6

802.11b Left Tilt Middle

Date/Time: 7/17/2013 10:34:21 AM

Communication System: 802.11b; Frequency: 2437 MHz; Duty Cycle: 1:1

Medium parameters used (interpolated): $f = 2437$ MHz; $\sigma = 1.865$ mho/m; $\epsilon_r = 38.323$; $\rho = 1000$ kg/m³

Ambient Temperature: 22.3 °C Liquid Temperature: 21.5 °C

Phantom section: Left Section

DASY5 Configuration:

Sensor-Surface: 4mm (Mechanical Surface Detection)

Probe: EX3DV4 - SN3753; ConvF(6.86, 6.86, 6.86); Calibrated: 1/17/2013;

Electronics: DAE4 Sn1317; Calibrated: 1/25/2013

Phantom: SAM 2; Type: SAM;

Measurement SW: DASY52, Version 52.8 (2); SEMCAD X Version 14.6.6 (6824)

Left Tilt Middle /Area Scan (7x12x1): Measurement grid: dx=12 mm, dy=12 mm

Maximum value of SAR (measured) = 0.431 W/kg

Left Tilt Middle /Zoom Scan (7x7x7)/Cube 0: Measurement grid: dx=5mm, dy=5mm, dz=5mm

Reference Value = 11.407 V/m; Power Drift = -0.16 dB

Peak SAR (extrapolated) = 0.811 mW/g

SAR(1 g) = 0.406 mW/g; SAR(10 g) = 0.219 mW/g

Maximum value of SAR (measured) = 0.425 W/kg

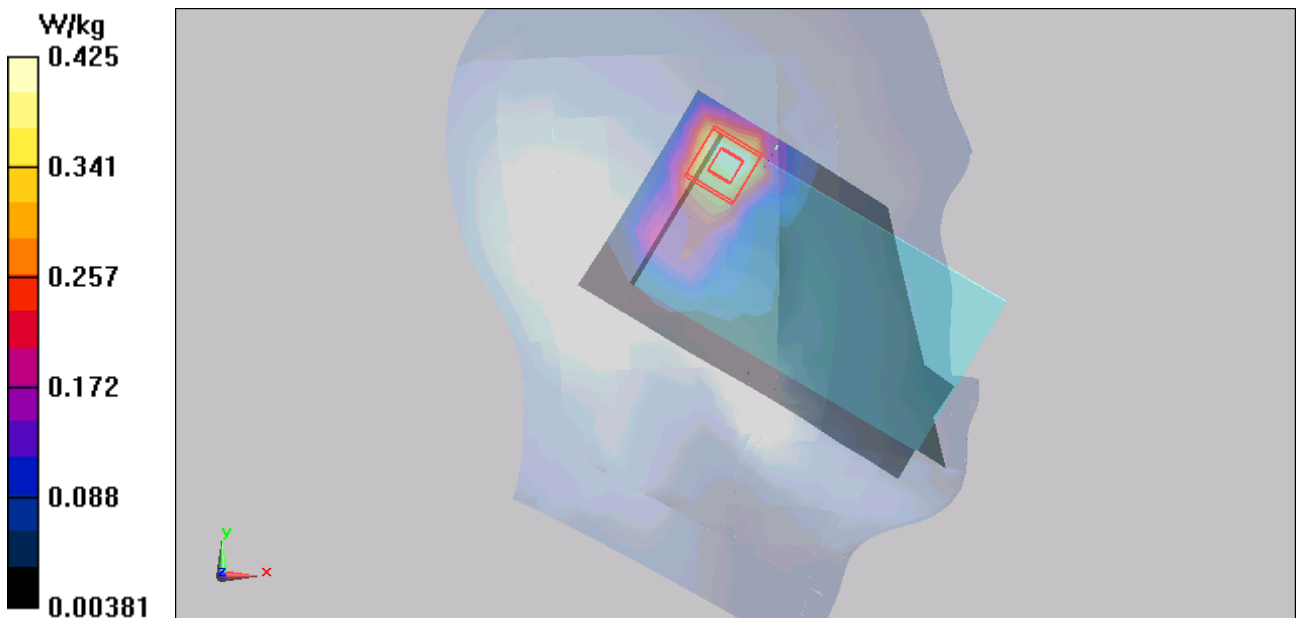

Figure 80 Left Hand Tilt 15° 802.11b Channel 6

802.11b Right Cheek Middle

Date/Time: 7/17/2013 9:44:36 AM

Communication System: 802.11b; Frequency: 2437 MHz; Duty Cycle: 1:1

Medium parameters used (interpolated): $f = 2437$ MHz; $\sigma = 1.865$ mho/m; $\epsilon_r = 38.323$; $\rho = 1000$ kg/m³

Ambient Temperature: 22.3 °C Liquid Temperature: 21.5 °C

Phantom section: Right Section

DASY5 Configuration:

Sensor-Surface: 4mm (Mechanical Surface Detection)

Probe: EX3DV4 - SN3753; ConvF(6.86, 6.86, 6.86); Calibrated: 1/17/2013;

Electronics: DAE4 Sn1317; Calibrated: 1/25/2013

Phantom: SAM 2; Type: SAM;

Measurement SW: DASY52, Version 52.8 (2); SEMCAD X Version 14.6.6 (6824)

Right Cheek Middle /Area Scan (7x12x1): Measurement grid: dx=12 mm, dy=12 mm

Maximum value of SAR (measured) = 0.362 W/kg

Right Cheek Middle /Zoom Scan (7x7x7)/Cube 0: Measurement grid: dx=5mm, dy=5mm, dz=5mm

Reference Value = 13.203 V/m; Power Drift = -0.024 dB

Peak SAR (extrapolated) = 0.603 mW/g

SAR(1 g) = 0.335 mW/g; SAR(10 g) = 0.186 mW/g

Maximum value of SAR (measured) = 0.360 W/kg

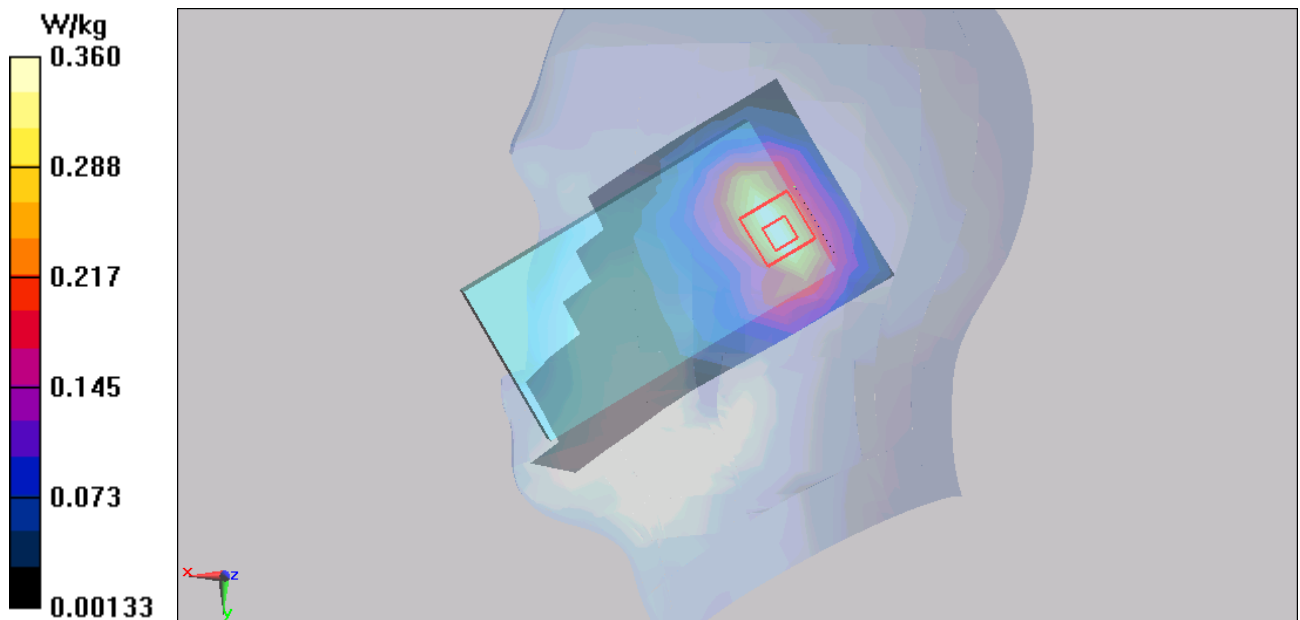

Figure 81 Right Hand Touch Cheek 802.11b Channel 6

802.11b Right Tilt Middle

Date/Time: 7/17/2013 10:15:06 AM

Communication System: 802.11b; Frequency: 2437 MHz; Duty Cycle: 1:1

Medium parameters used (interpolated): $f = 2437$ MHz; $\sigma = 1.865$ mho/m; $\epsilon_r = 38.323$; $\rho = 1000$ kg/m³

Ambient Temperature: 22.3 °C Liquid Temperature: 21.5 °C

Phantom section: Right Section

DASY5 Configuration:

Sensor-Surface: 4mm (Mechanical Surface Detection)

Probe: EX3DV4 - SN3753; ConvF(6.86, 6.86, 6.86); Calibrated: 1/17/2013;

Electronics: DAE4 Sn1317; Calibrated: 1/25/2013

Phantom: SAM 2; Type: SAM;

Measurement SW: DASY52, Version 52.8 (2); SEMCAD X Version 14.6.6 (6824)

Right Tilt Middle /Area Scan (7x12x1): Measurement grid: dx=12 mm, dy=12 mm

Maximum value of SAR (measured) = 0.277 W/kg

Right Tilt Middle /Zoom Scan (7x7x7)/Cube 0: Measurement grid: dx=5mm, dy=5mm, dz=5mm

Reference Value = 12.876 V/m; Power Drift = -0.08 dB

Peak SAR (extrapolated) = 0.605 mW/g

SAR(1 g) = 0.332 mW/g; SAR(10 g) = 0.172 mW/g

Maximum value of SAR (measured) = 0.374 W/kg

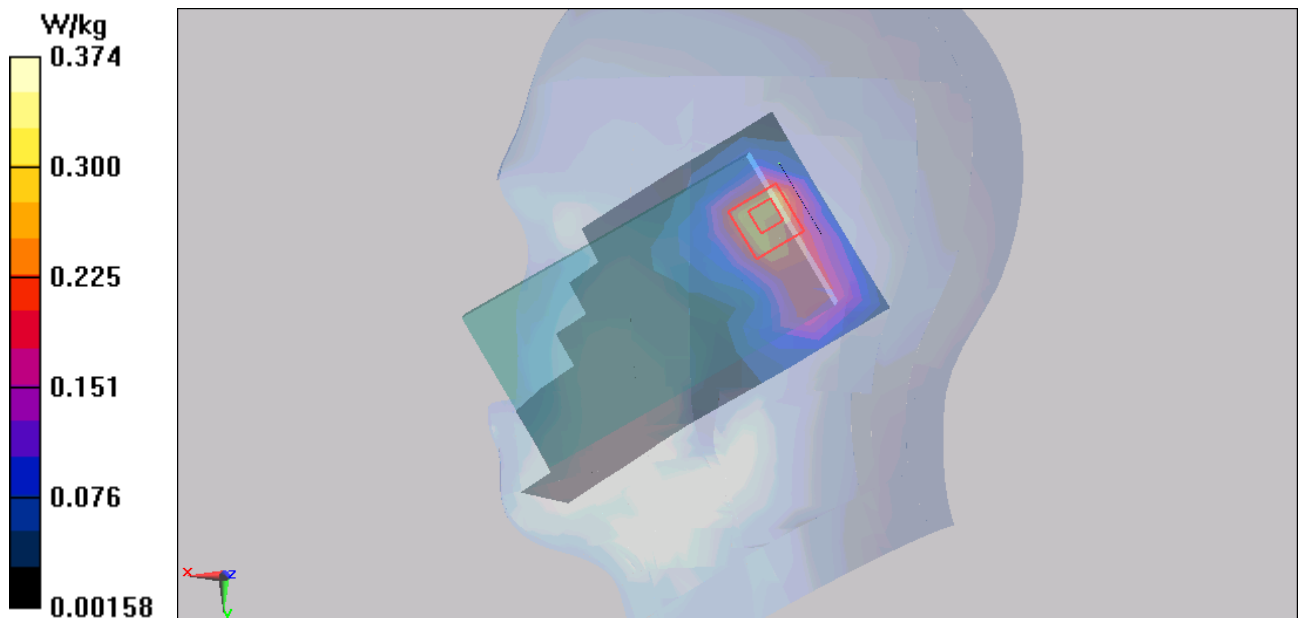

Figure 82 Right Hand Tilt 15° 802.11b Channel 6

802.11b Back Side Middle

Date/Time: 7/19/2013 8:11:48 AM

Communication System: 802.11b; Frequency: 2437 MHz; Duty Cycle: 1:1

Medium parameters used (interpolated): $f = 2437$ MHz; $\sigma = 1.884$ mho/m; $\epsilon_r = 51.707$; $\rho = 1000$ kg/m³

Ambient Temperature: 22.3 °C Liquid Temperature: 21.5 °C

Phantom section: Flat Section

DASY5 Configuration:

Sensor-Surface: 4mm (Mechanical Surface Detection)

Probe: EX3DV4 - SN3753; ConvF(6.90, 6.90, 6.90); Calibrated: 1/17/2013;

Electronics: DAE4 Sn1317; Calibrated: 1/25/2013

Phantom: SAM 2; Type: SAM;

Measurement SW: DASY52, Version 52.8 (2); SEMCAD X Version 14.6.6 (6824)

Back Side Middle /Area Scan (7x11x1): Measurement grid: dx=12 mm, dy=12 mm

Maximum value of SAR (measured) = 0.319 W/kg

Back Side Middle /Zoom Scan (7x7x7)/Cube 0: Measurement grid: dx=5mm, dy=5mm, dz=5mm

Reference Value = 6.183 V/m; Power Drift = 0.02 dB

Peak SAR (extrapolated) = 0.615 mW/g

SAR(1 g) = 0.290 mW/g; SAR(10 g) = 0.150 mW/g

Maximum value of SAR (measured) = 0.318 W/kg

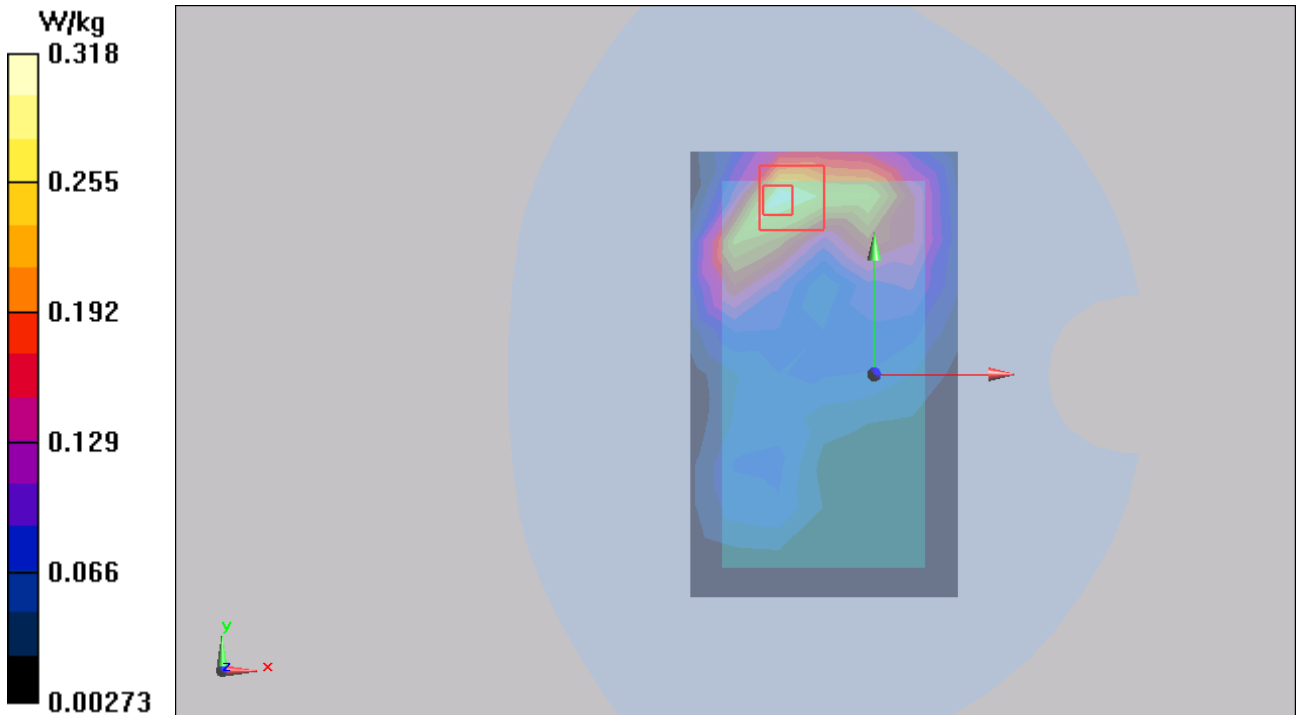

Figure 83 Body, Back Side, 802.11b Channel 6

802.11b Front Side Middle

Date/Time: 7/19/2013 7:09:48 PM

Communication System: 802.11b; Frequency: 2437 MHz; Duty Cycle: 1:1

Medium parameters used (interpolated): $f = 2437$ MHz; $\sigma = 1.884$ mho/m; $\epsilon_r = 51.707$; $\rho = 1000$ kg/m³

Ambient Temperature: 22.3 °C Liquid Temperature: 21.5 °C

Phantom section: Flat Section

DASY5 Configuration:

Sensor-Surface: 4mm (Mechanical Surface Detection)

Probe: EX3DV4 - SN3753; ConvF(6.90, 6.90, 6.90); Calibrated: 1/17/2013;

Electronics: DAE4 Sn1317; Calibrated: 1/25/2013

Phantom: SAM 2; Type: SAM;

Measurement SW: DASY52, Version 52.8 (2); SEMCAD X Version 14.6.6 (6824)

Front Side Middle /Area Scan (7x11x1): Measurement grid: dx=12 mm, dy=12 mm

Maximum value of SAR (measured) = 0.219 W/kg

Front Side Middle /Zoom Scan (7x7x7)/Cube 0: Measurement grid: dx=5mm, dy=5mm, dz=5mm

Reference Value = 6.440 V/m; Power Drift = 0.05 dB

Peak SAR (extrapolated) = 0.380 mW/g

SAR(1 g) = 0.201 mW/g; SAR(10 g) = 0.112 mW/g

Maximum value of SAR (measured) = 0.218 W/kg

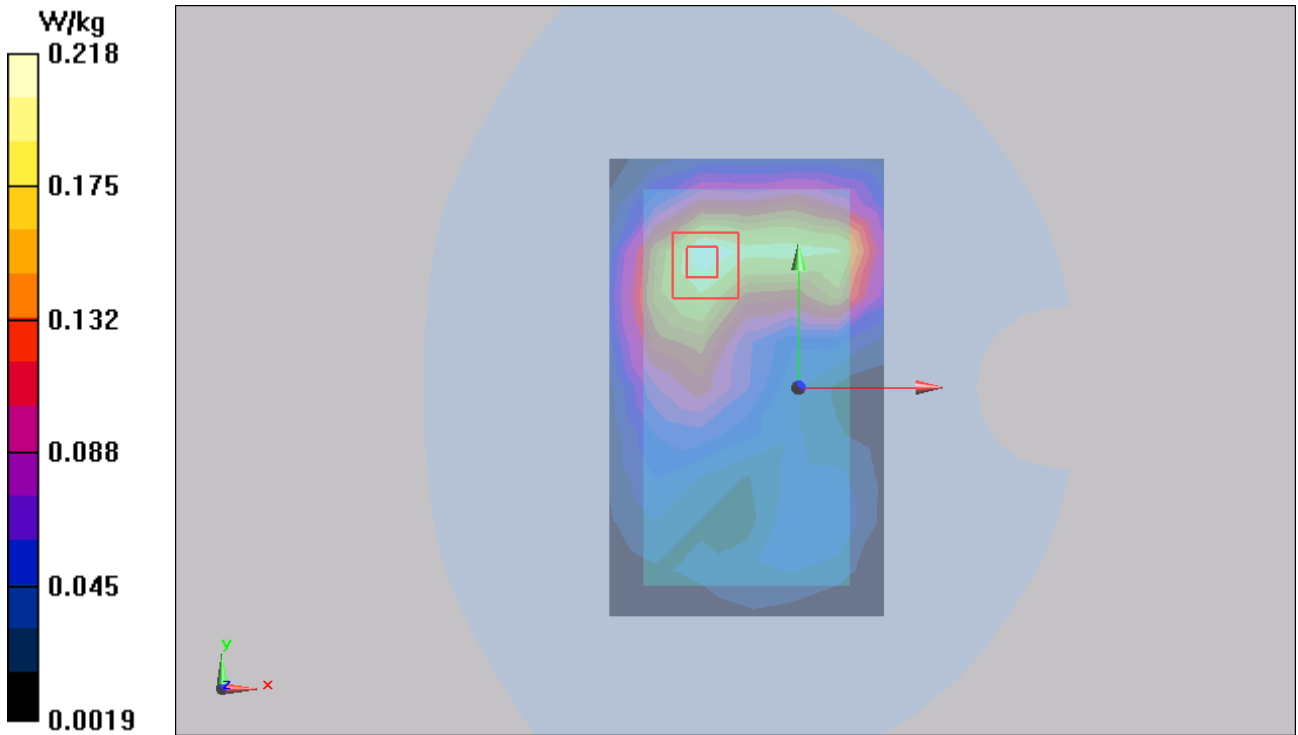

Figure 84 Body, Front Side, 802.11b Channel 6

802.11b Right Edge Middle

Date/Time: 7/19/2013 7:28:43 PM

Communication System: 802.11b; Frequency: 2437 MHz; Duty Cycle: 1:1

Medium parameters used (interpolated): $f = 2437$ MHz; $\sigma = 1.884$ mho/m; $\epsilon_r = 51.707$; $\rho = 1000$ kg/m³

Ambient Temperature: 22.3 °C Liquid Temperature: 21.5 °C

Phantom section: Flat Section

DASY5 Configuration:

Sensor-Surface: 4mm (Mechanical Surface Detection)

Probe: EX3DV4 - SN3753; ConvF(6.90, 6.90, 6.90); Calibrated: 1/17/2013;

Electronics: DAE4 Sn1317; Calibrated: 1/25/2013

Phantom: SAM 2; Type: SAM;

Measurement SW: DASY52, Version 52.8 (2); SEMCAD X Version 14.6.6 (6824)

Right Edge Middle /Area Scan (31x111x1): Interpolated grid: dx=12 mm, dy=12 mm

Maximum value of SAR (interpolated) = 0.312 W/kg

Right Edge Middle /Zoom Scan (7x7x7)/Cube 0: Measurement grid: dx=5mm, dy=5mm, dz=5mm

Reference Value = 6.667 V/m; Power Drift = 0.14 dB

Peak SAR (extrapolated) = 0.764 mW/g

SAR(1 g) = 0.321 mW/g; SAR(10 g) = 0.152 mW/g

Maximum value of SAR (measured) = 0.349 W/kg

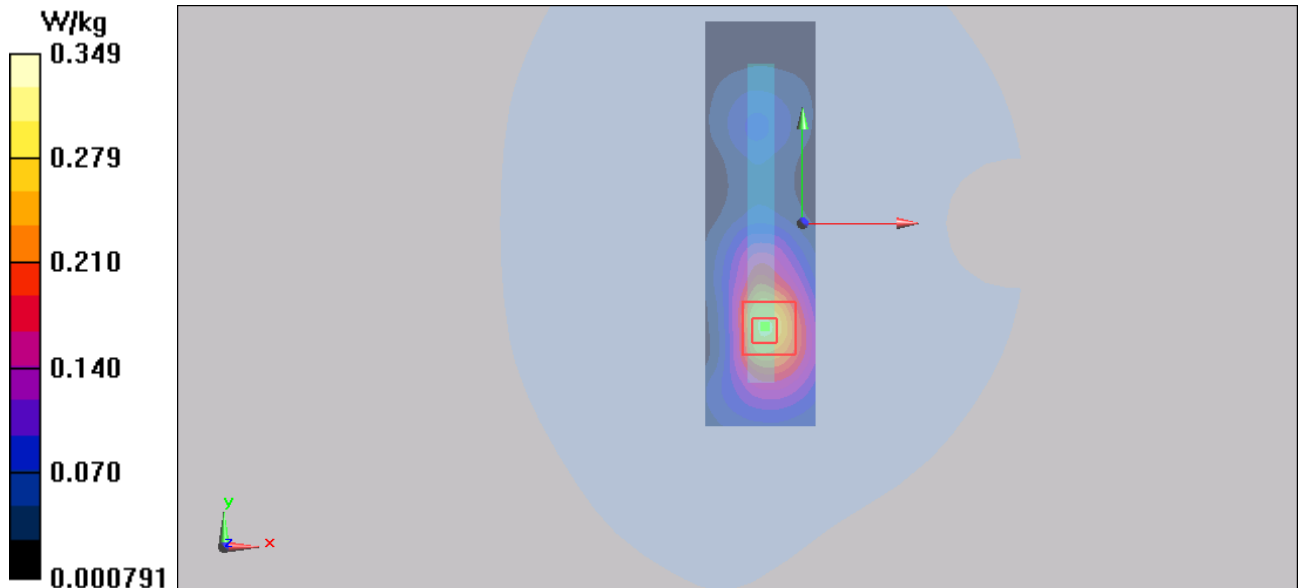

TA Technology (Shanghai) Co., Ltd.
Test Report

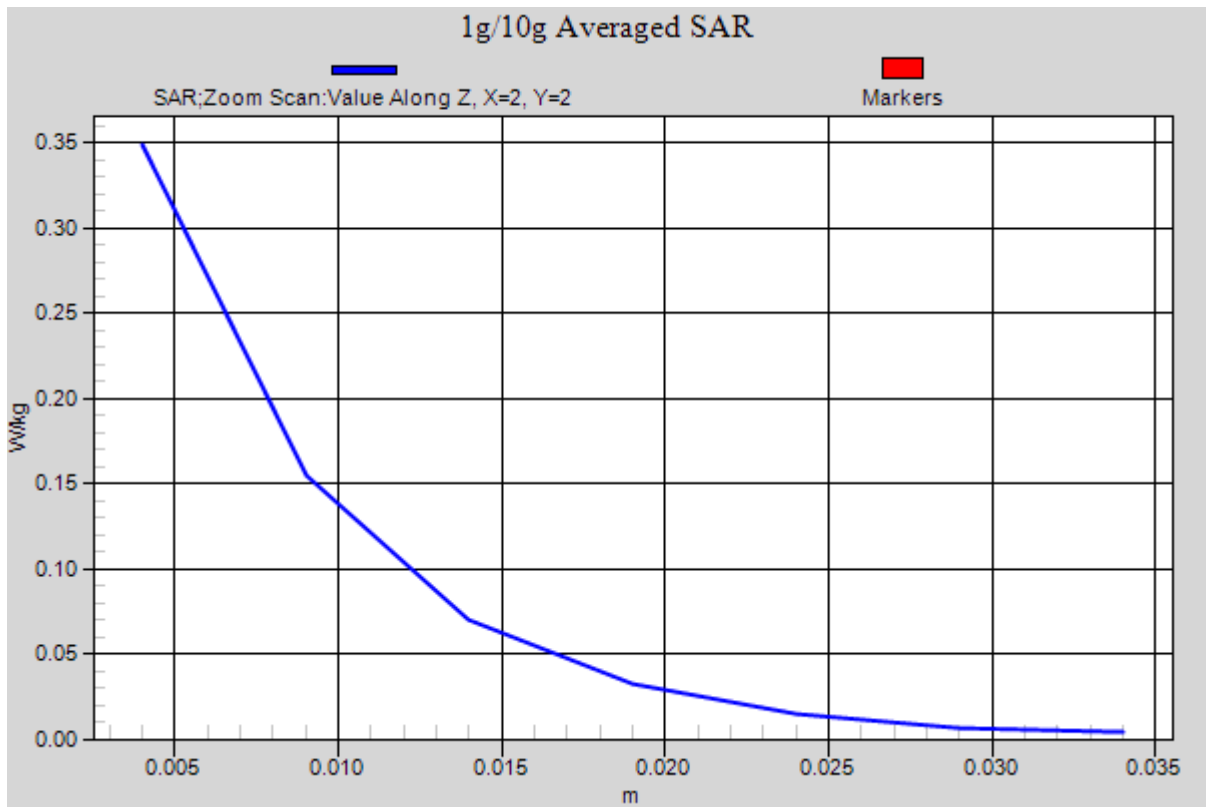

Figure 85 Body, Right Edge, 802.11b Channel 6

802.11b Top Edge Middle

Date/Time: 7/19/2013 7:43:52 PM

Communication System: 802.11b; Frequency: 2437 MHz; Duty Cycle: 1:1

Medium parameters used (interpolated): $f = 2437$ MHz; $\sigma = 1.884$ mho/m; $\epsilon_r = 51.707$; $\rho = 1000$ kg/m³

Ambient Temperature: 22.3 °C Liquid Temperature: 21.5 °C

Phantom section: Flat Section

DASY5 Configuration:

Sensor-Surface: 4mm (Mechanical Surface Detection)

Probe: EX3DV4 - SN3753; ConvF(6.90, 6.90, 6.90); Calibrated: 1/17/2013;

Electronics: DAE4 Sn1317; Calibrated: 1/25/2013

Phantom: SAM 2; Type: SAM;

Measurement SW: DASY52, Version 52.8 (2); SEMCAD X Version 14.6.6 (6824)

Top Edge Middle /Area Scan (41x61x1): Interpolated grid: dx=12 mm, dy=12 mm

Maximum value of SAR (interpolated) = 0.238 W/kg

Top Edge Middle /Zoom Scan (7x7x7)/Cube 0: Measurement grid: dx=5mm, dy=5mm, dz=5mm

Reference Value = 10.715 V/m; Power Drift = 0.07 dB

Peak SAR (extrapolated) = 0.433 mW/g

SAR(1 g) = 0.219 mW/g; SAR(10 g) = 0.115 mW/g

Maximum value of SAR (measured) = 0.239 W/kg

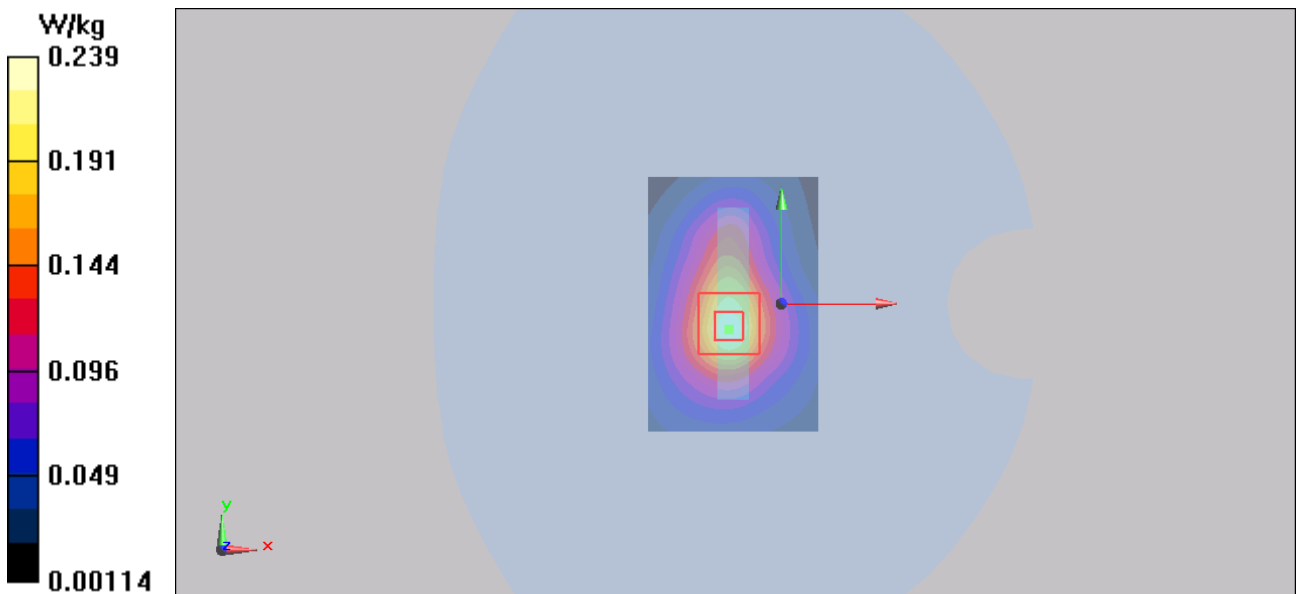

Figure 86 Body, Top Edge, 802.11b Channel 6

TA Technology (Shanghai) Co., Ltd. Test Report

Report No.: RXA1307-0093SAR01R3

Page 158 of 225

802.11b Back Side Middle(15 cm)

Date/Time: 8/1/2013 3:03:28 PM

Communication System: 802.11b; Frequency: 2437 MHz; Duty Cycle: 1:1

Medium parameters used (interpolated): $f = 2437$ MHz; $\sigma = 1.884$ mho/m; $\epsilon_r = 51.707$; $\rho = 1000$ kg/m³

Ambient Temperature: 22.3 °C Liquid Temperature: 21.5 °C

Phantom section: Flat Section

DASY5 Configuration:

Sensor-Surface: 4mm (Mechanical Surface Detection)

Probe: EX3DV4 - SN3753; ConvF(6.90, 6.90, 6.90); Calibrated: 1/17/2013;

Electronics: DAE4 Sn1317; Calibrated: 1/25/2013

Phantom: SAM 2; Type: SAM;

Measurement SW: DASY52, Version 52.8 (2); SEMCAD X Version 14.6.6 (6824)

Back Side Middle /Area Scan (61x101x1): Interpolated grid: dx=12 mm, dy=12 mm

Maximum value of SAR (interpolated) = 0.314 W/kg

Back Side Middle /Zoom Scan (7x7x7)/Cube 0: Measurement grid: dx=5mm, dy=5mm, dz=5mm

Reference Value = 7.328 V/m; Power Drift = -0.14 dB

Peak SAR (extrapolated) = 0.544 mW/g

SAR(1 g) = 0.280 mW/g; SAR(10 g) = 0.168 mW/g

Maximum value of SAR (measured) = 0.294 W/kg

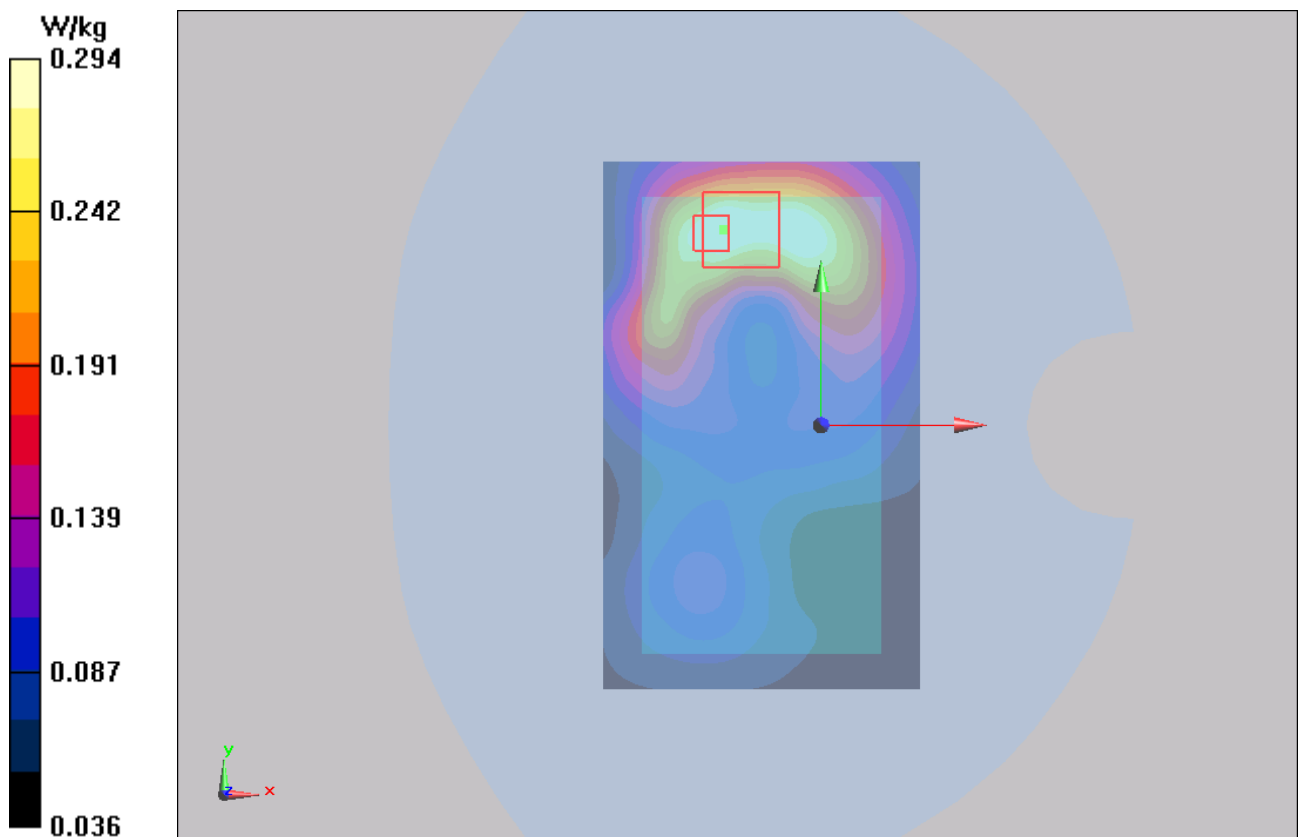

Figure 87 Body, Back Side, 802.11b Channel 6

BT Left Cheek Low

Date/Time: 7/17/2013 8:46:46 AM

Communication System: BT; Frequency: 2402 MHz; Duty Cycle: 1:1

Medium parameters used: $f = 2402$ MHz; $\sigma = 1.829$ mho/m; $\epsilon_r = 38.406$; $\rho = 1000$ kg/m³

Ambient Temperature: 22.3 °C Liquid Temperature: 21.5 °C

Phantom section: Left Section

DASY5 Configuration:

Sensor-Surface: 4mm (Mechanical Surface Detection)

Probe: EX3DV4 - SN3753; ConvF(6.86, 6.86, 6.86); Calibrated: 1/17/2013;

Electronics: DAE4 Sn1317; Calibrated: 1/25/2013

Phantom: SAM 2; Type: SAM;

Measurement SW: DASY52, Version 52.8 (2); SEMCAD X Version 14.6.6 (6824)

Left Cheek Low /Area Scan (61x111x1): Interpolated grid: dx=12 mm, dy=12 mm

Maximum value of SAR (interpolated) = 0.0813 W/kg

Left Cheek Low /Zoom Scan (7x7x7)/Cube 0: Measurement grid: dx=5mm, dy=5mm, dz=5mm

Reference Value = 6.317 V/m; Power Drift = 0.02 dB

Peak SAR (extrapolated) = 0.080 mW/g

SAR(1 g) = 0.0798 mW/g; SAR(10 g) = 0.079 mW/g

Maximum value of SAR (measured) = 0.0804 W/kg

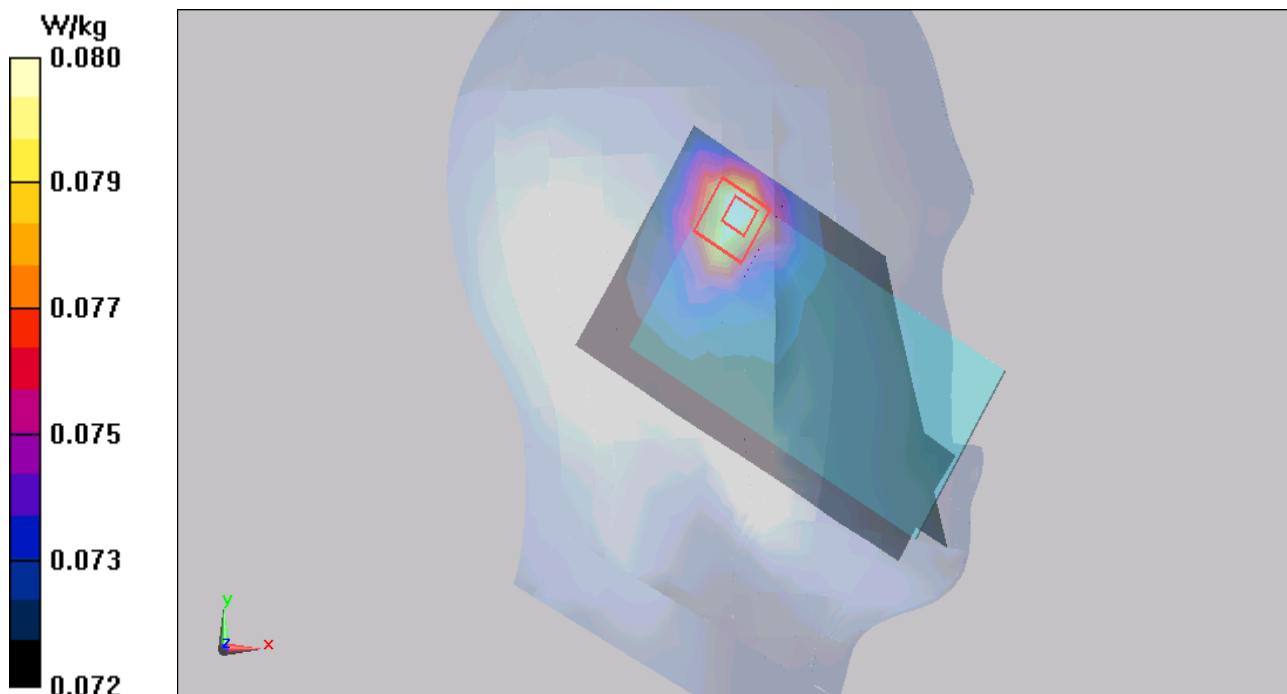

Figure 88 Left Hand Touch Cheek BT Channel 0

BT Left Tilt Low

Date/Time: 7/17/2013 9:57:29 AM

Communication System: BT; Frequency: 2402 MHz; Duty Cycle: 1:1

Medium parameters used: $f = 2402$ MHz; $\sigma = 1.829$ mho/m; $\epsilon_r = 38.406$; $\rho = 1000$ kg/m³

Ambient Temperature: 22.3 °C Liquid Temperature: 21.5 °C

Phantom section: Left Section

DASY5 Configuration:

Sensor-Surface: 4mm (Mechanical Surface Detection)

Probe: EX3DV4 - SN3753; ConvF(6.86, 6.86, 6.86); Calibrated: 1/17/2013;

Electronics: DAE4 Sn1317; Calibrated: 1/25/2013

Phantom: SAM 2; Type: SAM;

Measurement SW: DASY52, Version 52.8 (2); SEMCAD X Version 14.6.6 (6824)

Left Tilt Low /Area Scan (61x111x1): Interpolated grid: dx=12 mm, dy=12 mm

Maximum value of SAR (interpolated) = 0.0716 W/kg

Left Tilt Low /Zoom Scan (7x7x7)/Cube 0: Measurement grid: dx=5mm, dy=5mm, dz=5mm

Reference Value = 6.024 V/m; Power Drift = 0.05 dB

Peak SAR (extrapolated) = 0.069 mW/g

SAR(1 g) = 0.0688 mW/g; SAR(10 g) = 0.069 mW/g

Maximum value of SAR (measured) = 0.0694 W/kg

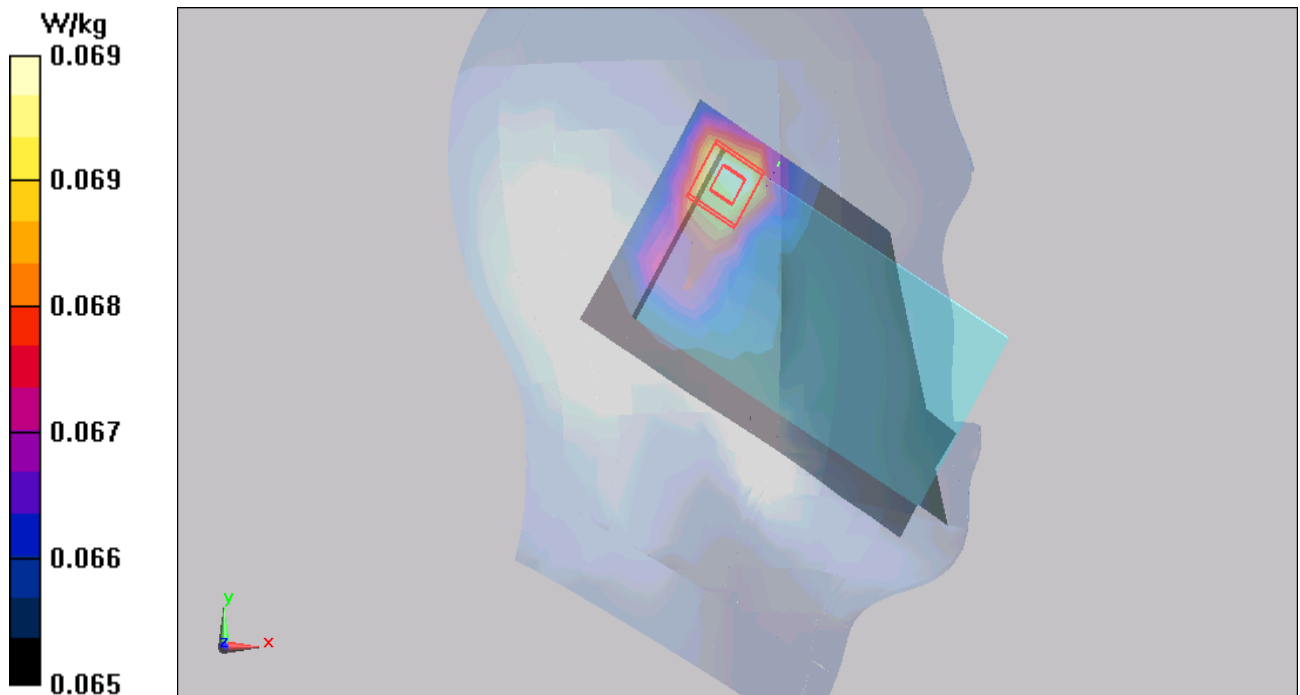

Figure 89 Left Hand Tilt 15° BT Channel 0

TA Technology (Shanghai) Co., Ltd. Test Report

Report No.: RXA1307-0093SAR01R3

Page 161 of 225

BT Right Cheek Low

Date/Time: 7/17/2013 9:10:31 AM

Communication System: BT; Frequency: 2402 MHz; Duty Cycle: 1:1

Medium parameters used: $f = 2402$ MHz; $\sigma = 1.829$ mho/m; $\epsilon_r = 38.406$; $\rho = 1000$ kg/m³

Ambient Temperature: 22.3 °C Liquid Temperature: 21.5 °C

Phantom section: Right Section

DASY5 Configuration:

Sensor-Surface: 4mm (Mechanical Surface Detection)

Probe: EX3DV4 - SN3753; ConvF(6.86, 6.86, 6.86); Calibrated: 1/17/2013;

Electronics: DAE4 Sn1317; Calibrated: 1/25/2013

Phantom: SAM 2; Type: SAM;

Measurement SW: DASY52, Version 52.8 (2); SEMCAD X Version 14.6.6 (6824)

Right Cheek Low /Area Scan (61x111x1): Interpolated grid: dx=12 mm, dy=12 mm

Maximum value of SAR (interpolated) = 0.143 W/kg

Right Cheek Low /Zoom Scan (7x7x7)/Cube 0: Measurement grid: dx=5mm, dy=5mm, dz=5mm

Reference Value = 7.616 V/m; Power Drift = -0.06 dB

Peak SAR (extrapolated) = 0.147 mW/g

SAR(1 g) = 0.118 mW/g; SAR(10 g) = 0.110 mW/g

Maximum value of SAR (measured) = 0.110 W/kg

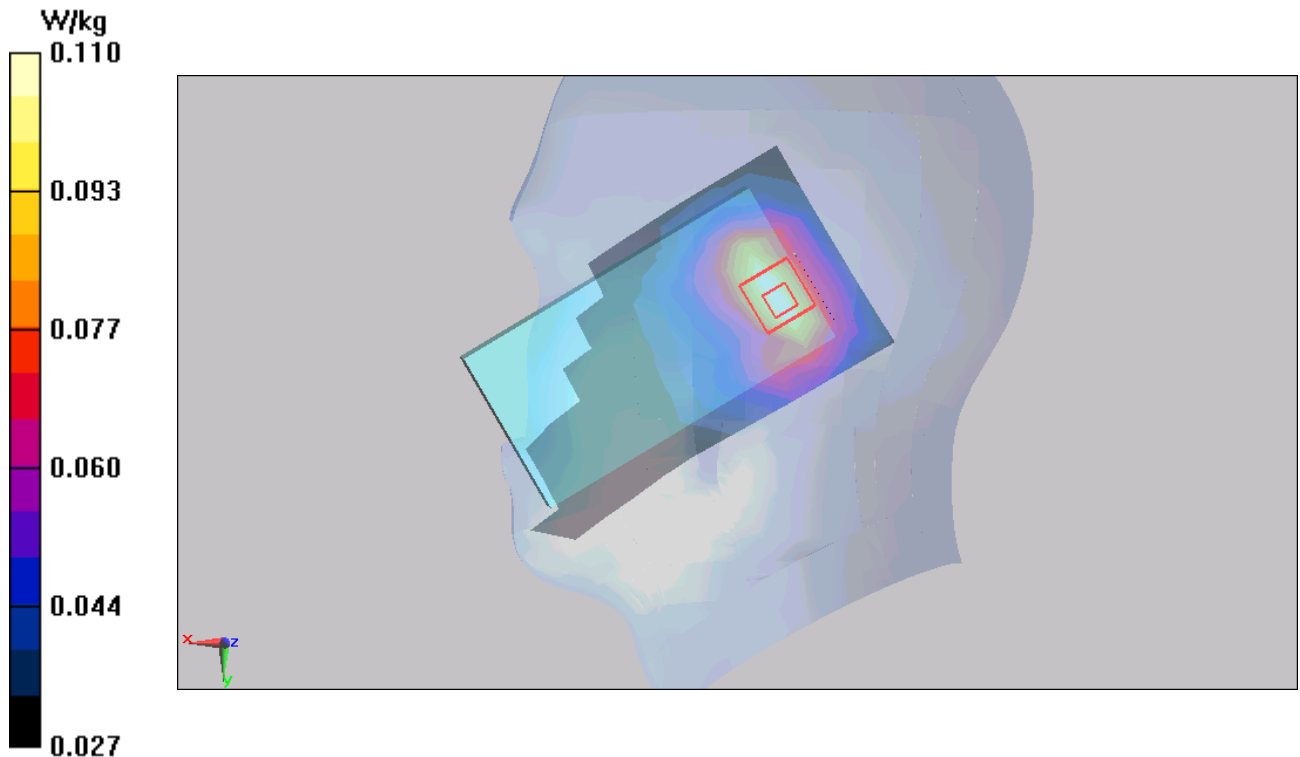

TA Technology (Shanghai) Co., Ltd.
Test Report

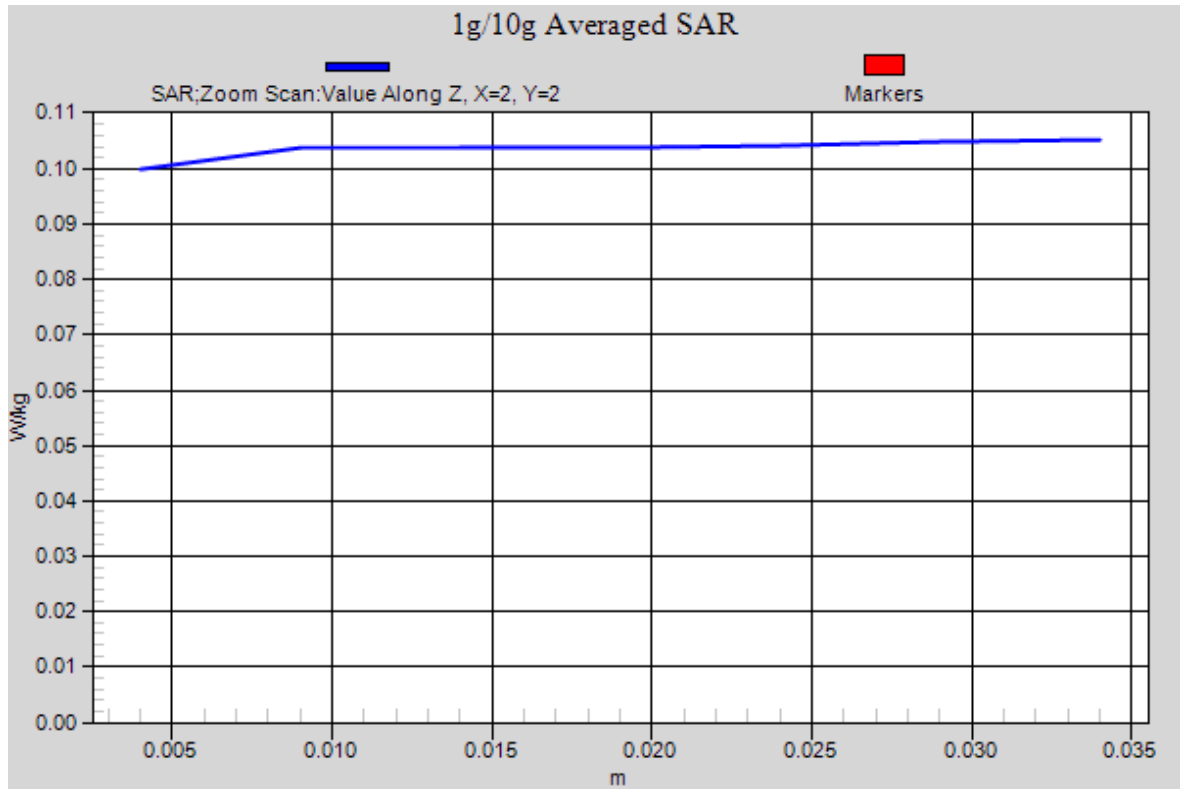

Figure 90 Right Hand Touch Cheek BT Channel 0

BT Right Tilt Low

Date/Time: 7/17/2013 10:47:42 AM

Communication System: BT; Frequency: 2402 MHz; Duty Cycle: 1:1

Medium parameters used: $f = 2402$ MHz; $\sigma = 1.829$ mho/m; $\epsilon_r = 38.406$; $\rho = 1000$ kg/m³

Ambient Temperature: 22.3 °C Liquid Temperature: 21.5 °C

Phantom section: Right Section

DASY5 Configuration:

Sensor-Surface: 4mm (Mechanical Surface Detection)

Probe: EX3DV4 - SN3753; ConvF(6.86, 6.86, 6.86); Calibrated: 1/17/2013;

Electronics: DAE4 Sn1317; Calibrated: 1/25/2013

Phantom: SAM 2; Type: SAM;

Measurement SW: DASY52, Version 52.8 (2); SEMCAD X Version 14.6.6 (6824)

Right Tilt Low /Area Scan (61x111x1): Interpolated grid: dx=12 mm, dy=12 mm

Maximum value of SAR (interpolated) = 0.253 W/kg

Right Tilt Low /Zoom Scan (7x7x7)/Cube 0: Measurement grid: dx=5mm, dy=5mm, dz=5mm

Reference Value = 3.206 V/m; Power Drift = 0.07 dB

Peak SAR (extrapolated) = 0.107 mW/g

SAR(1 g) = 0.105 mW/g; SAR(10 g) = 0.102 mW/g

Maximum value of SAR (measured) = 0.107 W/kg

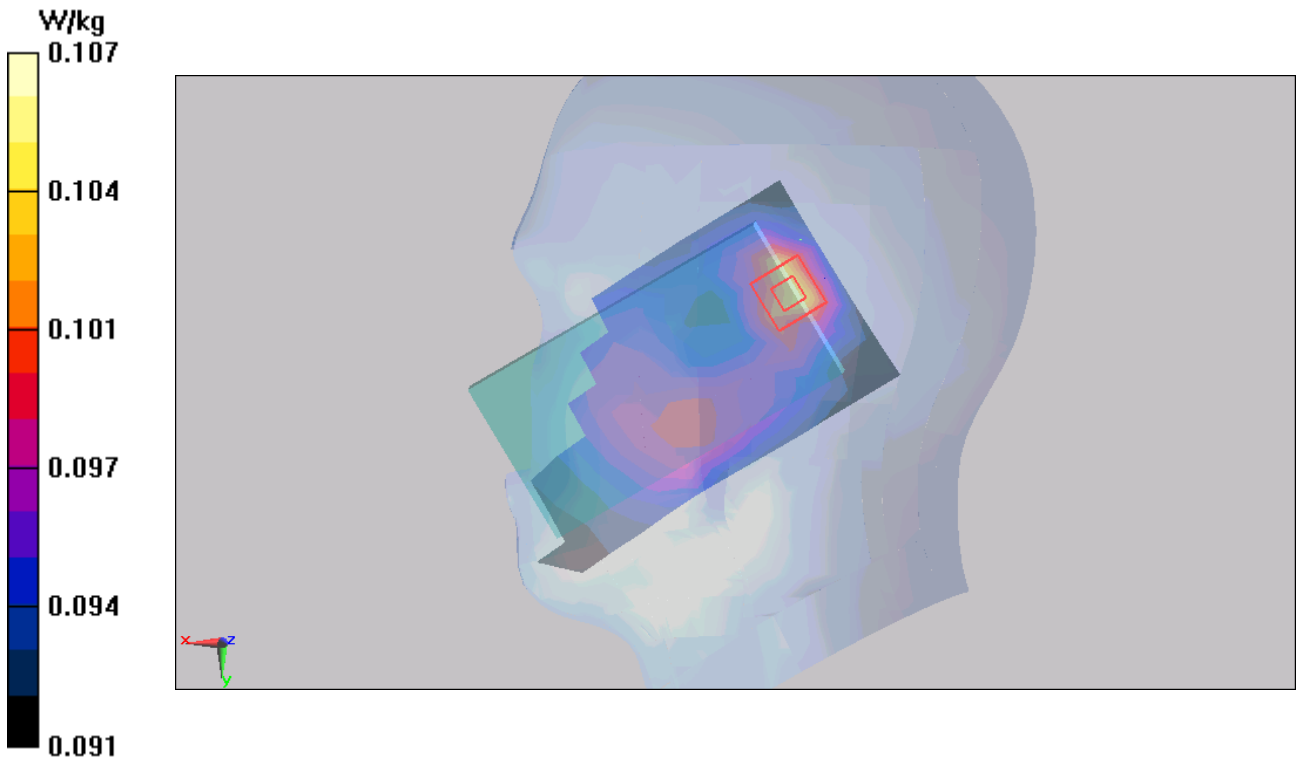

Figure 91 Right Hand Tilt 15° BT Channel 0

TA Technology (Shanghai) Co., Ltd. Test Report

Report No.: RXA1307-0093SAR01R3

Page 164 of 225

BT Back Side Low

Date/Time: 7/19/2013 10:14:20 PM

Communication System: BT; Frequency: 2402 MHz; Duty Cycle: 1:1

Medium parameters used: $f = 2402$ MHz; $\sigma = 1.835$ mho/m; $\epsilon_r = 51.765$; $\rho = 1000$ kg/m³

Ambient Temperature: 22.3 °C Liquid Temperature: 21.5 °C

Phantom section: Flat Section

DASY5 Configuration:

Sensor-Surface: 4mm (Mechanical Surface Detection)

Probe: EX3DV4 - SN3753; ConvF(6.90, 6.90, 6.90); Calibrated: 1/17/2013;

Electronics: DAE4 Sn1317; Calibrated: 1/25/2013

Phantom: SAM 2; Type: SAM;

Measurement SW: DASY52, Version 52.8 (2); SEMCAD X Version 14.6.6 (6824)

Back Side Low /Area Scan (61x101x1): Interpolated grid: dx=12 mm, dy=12 mm

Maximum value of SAR (interpolated) = 0.0379 W/kg

Back Side Low /Zoom Scan (7x7x7)/Cube 0: Measurement grid: dx=5mm, dy=5mm, dz=5mm

Reference Value = 4.349 V/m; Power Drift = -0.14 dB

Peak SAR (extrapolated) = 0.036 mW/g

SAR(1 g) = 0.0357 mW/g; SAR(10 g) = 0.035 mW/g

Maximum value of SAR (measured) = 0.0361 W/kg

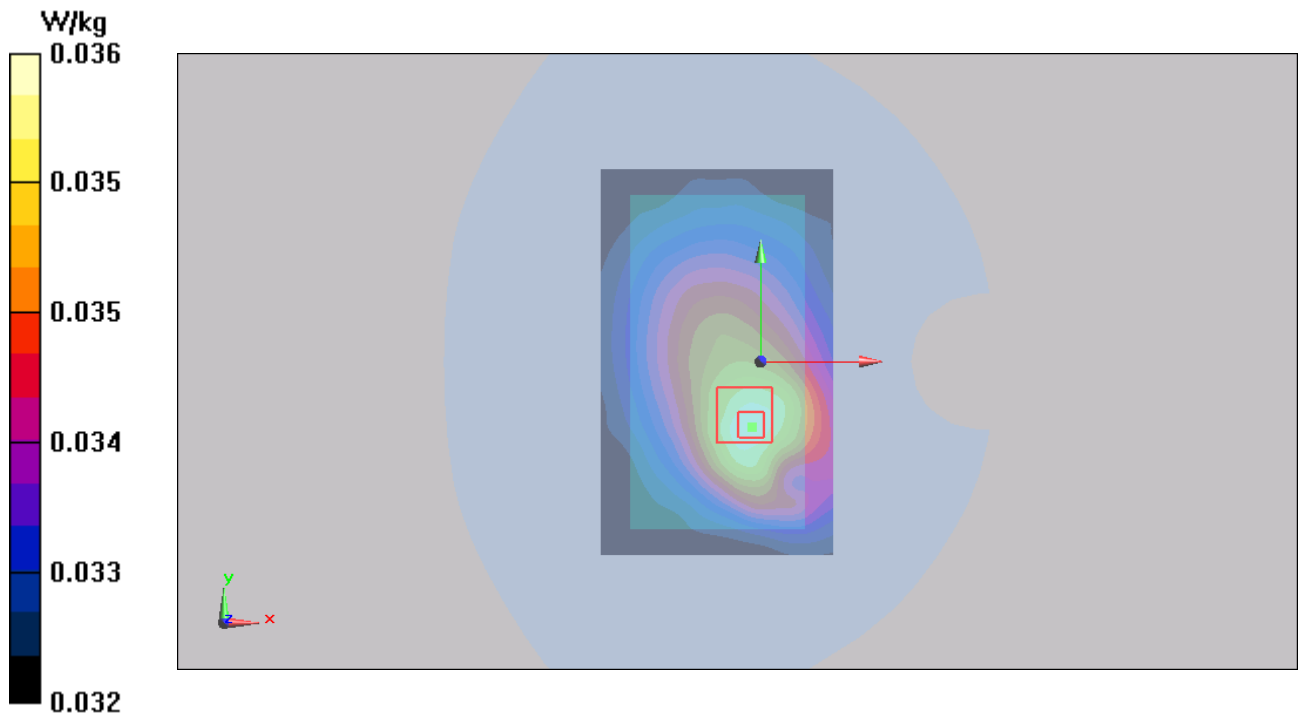

TA Technology (Shanghai) Co., Ltd.
Test Report

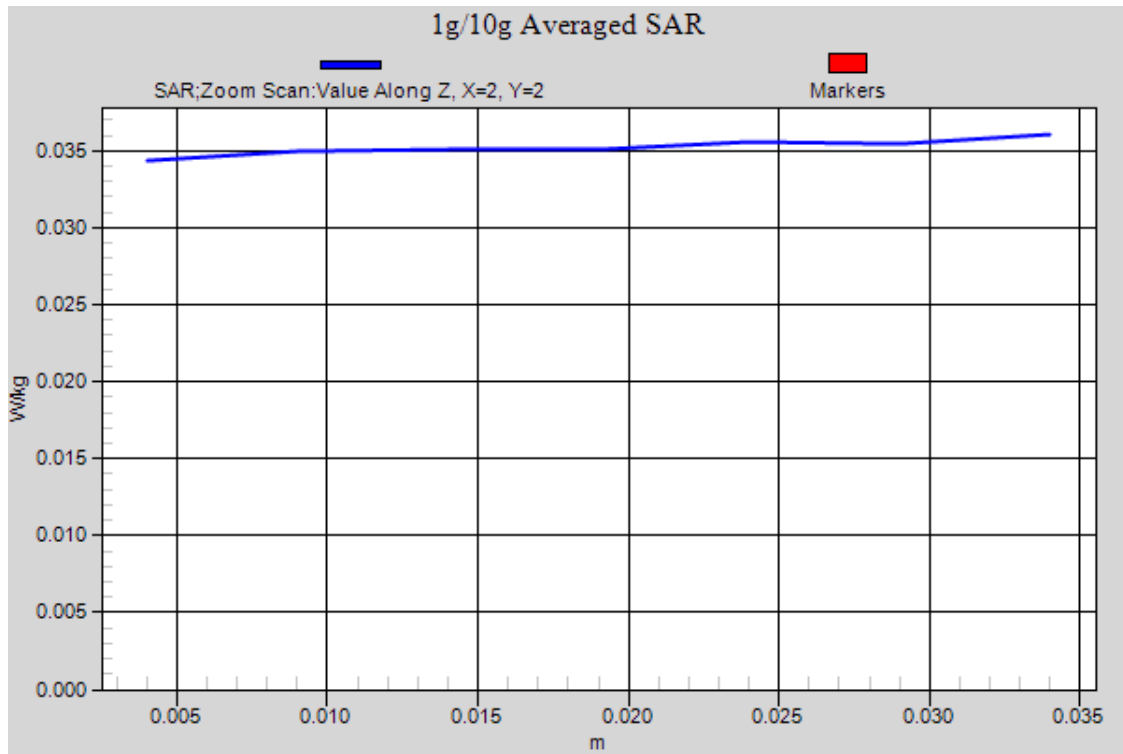

Figure 92 Body, Back Side, BT Channel 0

BT Front Side Low

Date/Time: 7/19/2013 11:23:35 PM

Communication System: BT; Frequency: 2402 MHz; Duty Cycle: 1:1

Medium parameters used: $f = 2402$ MHz; $\sigma = 1.835$ mho/m; $\epsilon_r = 51.765$; $\rho = 1000$ kg/m³

Ambient Temperature: 22.3 °C Liquid Temperature: 21.5 °C

Phantom section: Flat Section

DASY5 Configuration:

Sensor-Surface: 4mm (Mechanical Surface Detection)

Probe: EX3DV4 - SN3753; ConvF(6.90, 6.90, 6.90); Calibrated: 1/17/2013;

Electronics: DAE4 Sn1317; Calibrated: 1/25/2013

Phantom: SAM 2; Type: SAM;

Measurement SW: DASY52, Version 52.8 (2); SEMCAD X Version 14.6.6 (6824)

Front Side Low /Area Scan (61x101x1): Interpolated grid: dx=12 mm, dy=12 mm

Maximum value of SAR (interpolated) = 0.0280 W/kg

Front Side Low /Zoom Scan (7x7x7)/Cube 0: Measurement grid: dx=5mm, dy=5mm, dz=5mm

Reference Value = 3.748 V/m; Power Drift = 0.02 dB

Peak SAR (extrapolated) = 0.027 mW/g

SAR(1 g) = 0.0265 mW/g; SAR(10 g) = 0.026 mW/g

Maximum value of SAR (measured) = 0.0272 W/kg

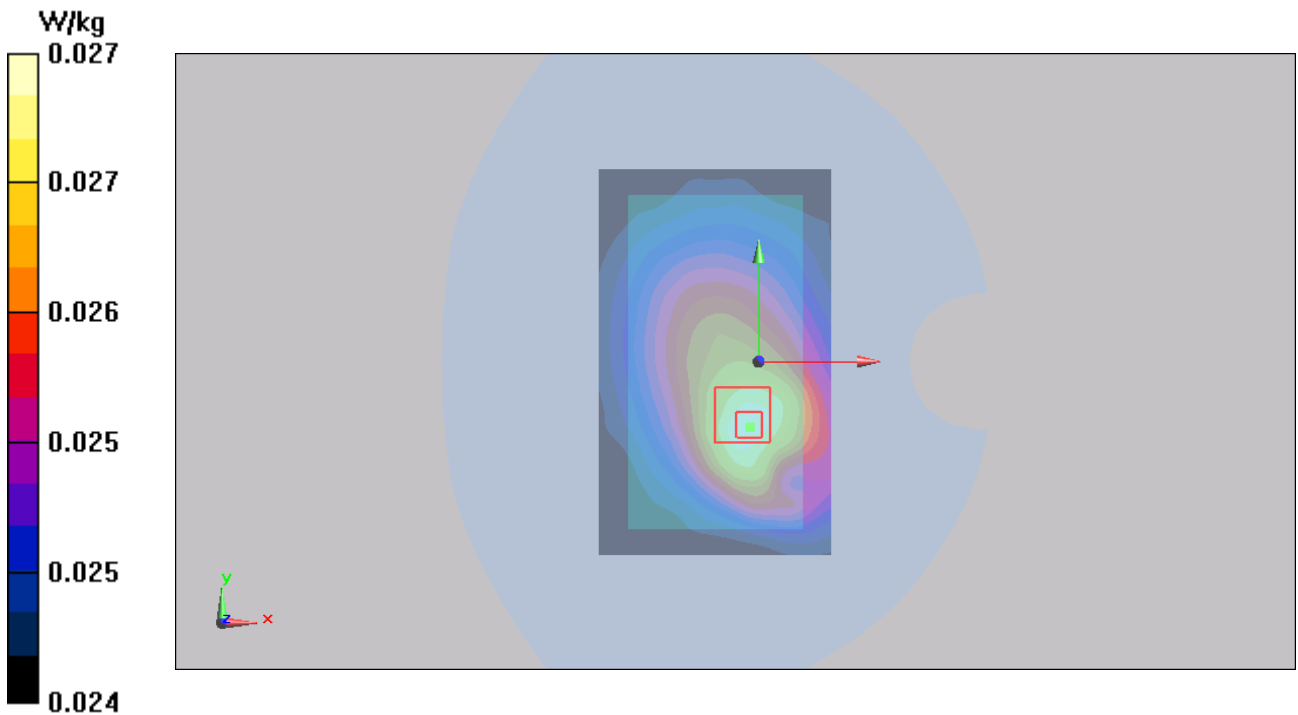

Figure 93 Body, Front Side, BT Channel 0

TA Technology (Shanghai) Co., Ltd.
Test Report

Report No.: RXA1307-0093SAR01R3

Page 167 of 225

BT Right Edge Low

Date/Time: 7/19/2013 11:52:04 PM

Communication System: BT; Frequency: 2402 MHz; Duty Cycle: 1:1

Medium parameters used: $f = 2402$ MHz; $\sigma = 1.835$ mho/m; $\epsilon_r = 51.765$; $\rho = 1000$ kg/m³

Ambient Temperature: 22.3 °C Liquid Temperature: 21.5 °C

Phantom section: Flat Section

DASY5 Configuration:

Sensor-Surface: 4mm (Mechanical Surface Detection)

Probe: EX3DV4 - SN3753; ConvF(6.90, 6.90, 6.90); Calibrated: 1/17/2013;

Electronics: DAE4 Sn1317; Calibrated: 1/25/2013

Phantom: SAM 2; Type: SAM;

Measurement SW: DASY52, Version 52.8 (2); SEMCAD X Version 14.6.6 (6824)

Right Edge Low /Area Scan (31x111x1): Interpolated grid: dx=12 mm, dy=12 mm

Maximum value of SAR (interpolated) = 0.0265 W/kg

Right Edge Low /Zoom Scan (7x7x7)/Cube 0: Measurement grid: dx=5mm, dy=5mm, dz=5mm

Reference Value = 3.582 V/m; Power Drift = 0.04 dB

Peak SAR (extrapolated) = 0.025 mW/g

SAR(1 g) = 0.0241 mW/g; SAR(10 g) = 0.024 mW/g

Maximum value of SAR (measured) = 0.0249 W/kg

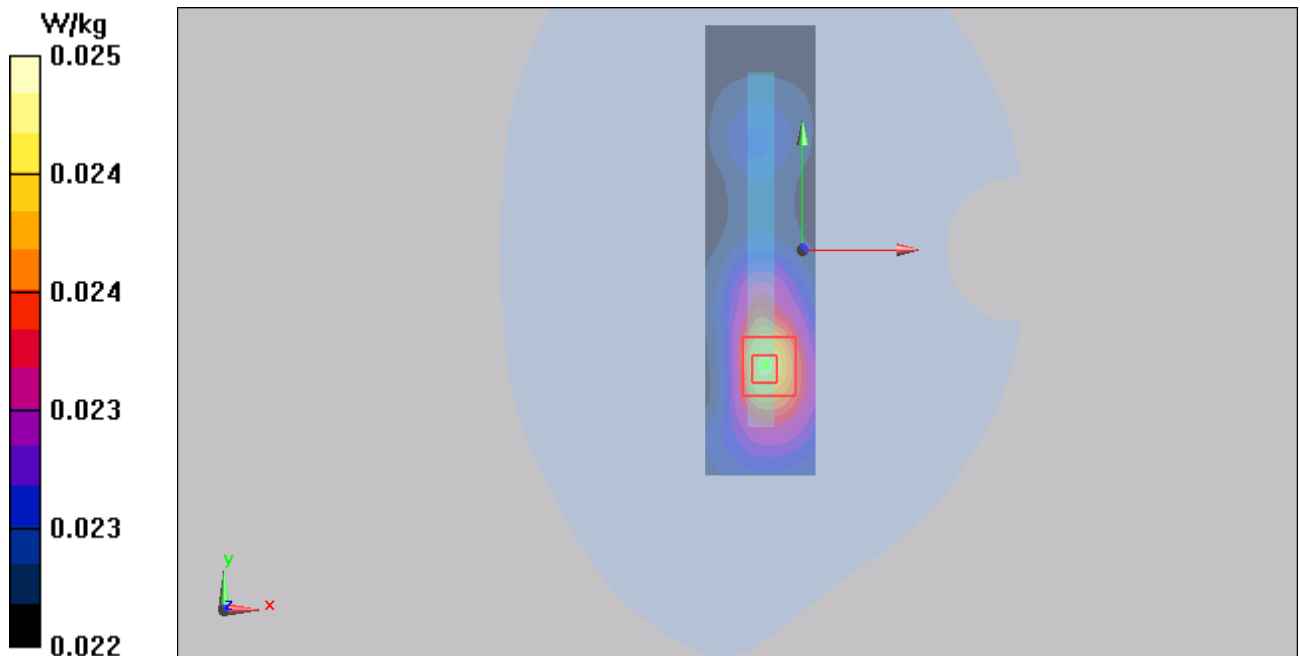

Figure 94 Body, Right Edge, BT Channel 0

BT Top Edge Low

Date/Time: 7/20/2013 12:19:02 AM

Communication System: BT; Frequency: 2402 MHz; Duty Cycle: 1:1

Medium parameters used: $f = 2402$ MHz; $\sigma = 1.835$ mho/m; $\epsilon_r = 51.765$; $\rho = 1000$ kg/m³

Ambient Temperature: 22.3 °C Liquid Temperature: 21.5 °C

Phantom section: Flat Section

DASY5 Configuration:

Sensor-Surface: 4mm (Mechanical Surface Detection)

Probe: EX3DV4 - SN3753; ConvF(6.90, 6.90, 6.90); Calibrated: 1/17/2013;

Electronics: DAE4 Sn1317; Calibrated: 1/25/2013

Phantom: SAM 2; Type: SAM;

Measurement SW: DASY52, Version 52.8 (2); SEMCAD X Version 14.6.6 (6824)

Top Edge Low /Area Scan (41x61x1): Interpolated grid: dx=12 mm, dy=12 mm

Maximum value of SAR (interpolated) = 0.0235 W/kg

Top Edge Low /Zoom Scan (7x7x7)/Cube 0: Measurement grid: dx=5mm, dy=5mm, dz=5mm

Reference Value = 3.514 V/m; Power Drift = -0.02 dB

Peak SAR (extrapolated) = 0.029 mW/g

SAR(1 g) = 0.0234 mW/g; SAR(10 g) = 0.023 mW/g

Maximum value of SAR (measured) = 0.0240 W/kg

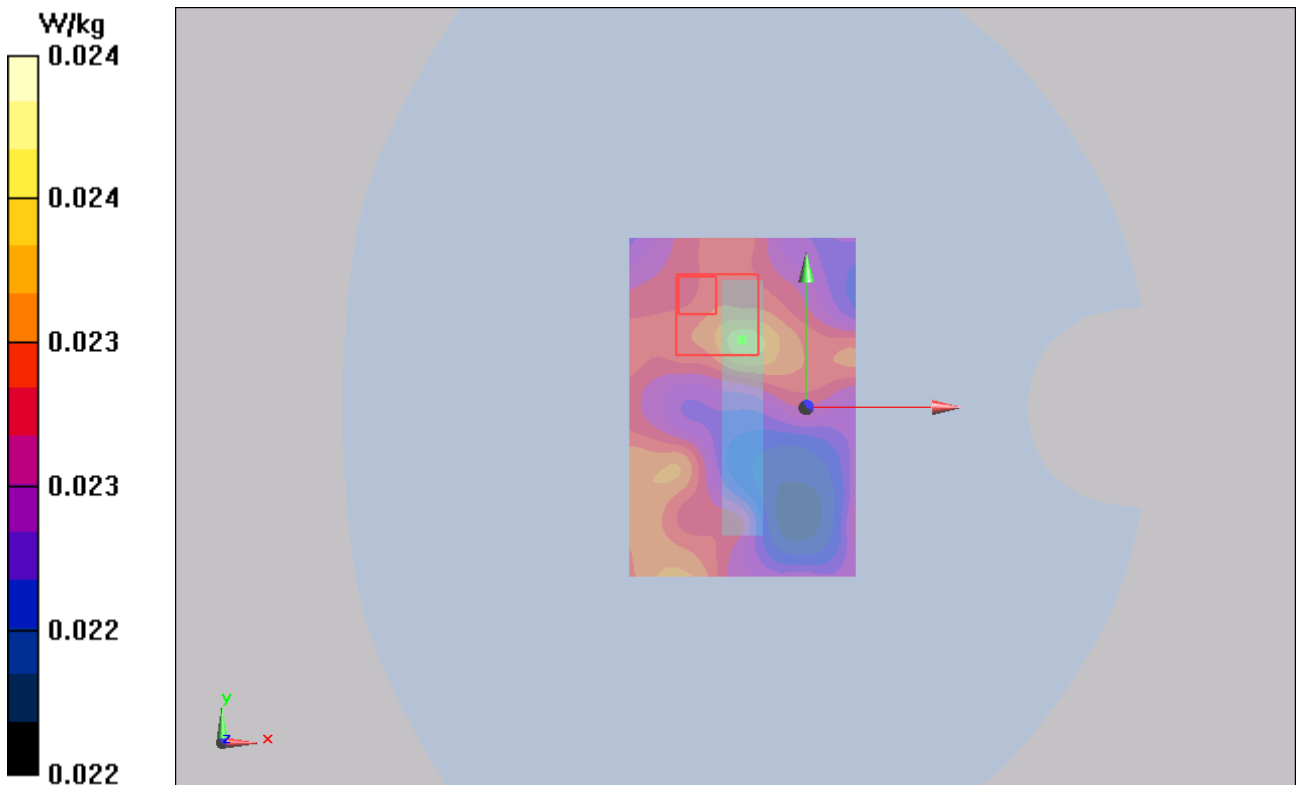

Figure 95 Body, Top Edge, BT Channel 0

TA Technology (Shanghai) Co., Ltd. Test Report

Report No.: RXA1307-0093SAR01R3

Page 169 of 225

BT Back Side Low(15 cm)

Date/Time: 8/1/2013 3:25:16 PM

Communication System: BT; Frequency: 2402 MHz;Duty Cycle: 1:1

Medium parameters used: $f = 2402$ MHz; $\sigma = 1.835$ mho/m; $\epsilon_r = 51.765$; $\rho = 1000$ kg/m³

Ambient Temperature:22.3 °C Liquid Temperature: 21.5°C

Phantom section: Flat Section

DASY5 Configuration:

Sensor-Surface: 4mm (Mechanical Surface Detection)

Probe: EX3DV4 - SN3753; ConvF(6.90, 6.90, 6.90); Calibrated: 1/17/2013;

Electronics: DAE4 Sn1317; Calibrated: 1/25/2013

Phantom: SAM 2; Type: SAM;

Measurement SW: DASY52, Version 52.8 (2); SEMCAD X Version 14.6.6 (6824)

Back Side Low /Area Scan (61x101x1): Interpolated grid: dx=12 mm, dy=12 mm

Maximum value of SAR (interpolated) = 0.0298 W/kg

Back Side Low /Zoom Scan (7x7x7)/Cube 0: Measurement grid: dx=5mm, dy=5mm, dz=5mm

Reference Value = 3.924 V/m; Power Drift = -0.090 dB

Peak SAR (extrapolated) = 0.029 mW/g

SAR(1 g) = 0.0271 mW/g; SAR(10 g) = 0.025 mW/g

Maximum value of SAR (measured) = 0.0280 W/kg

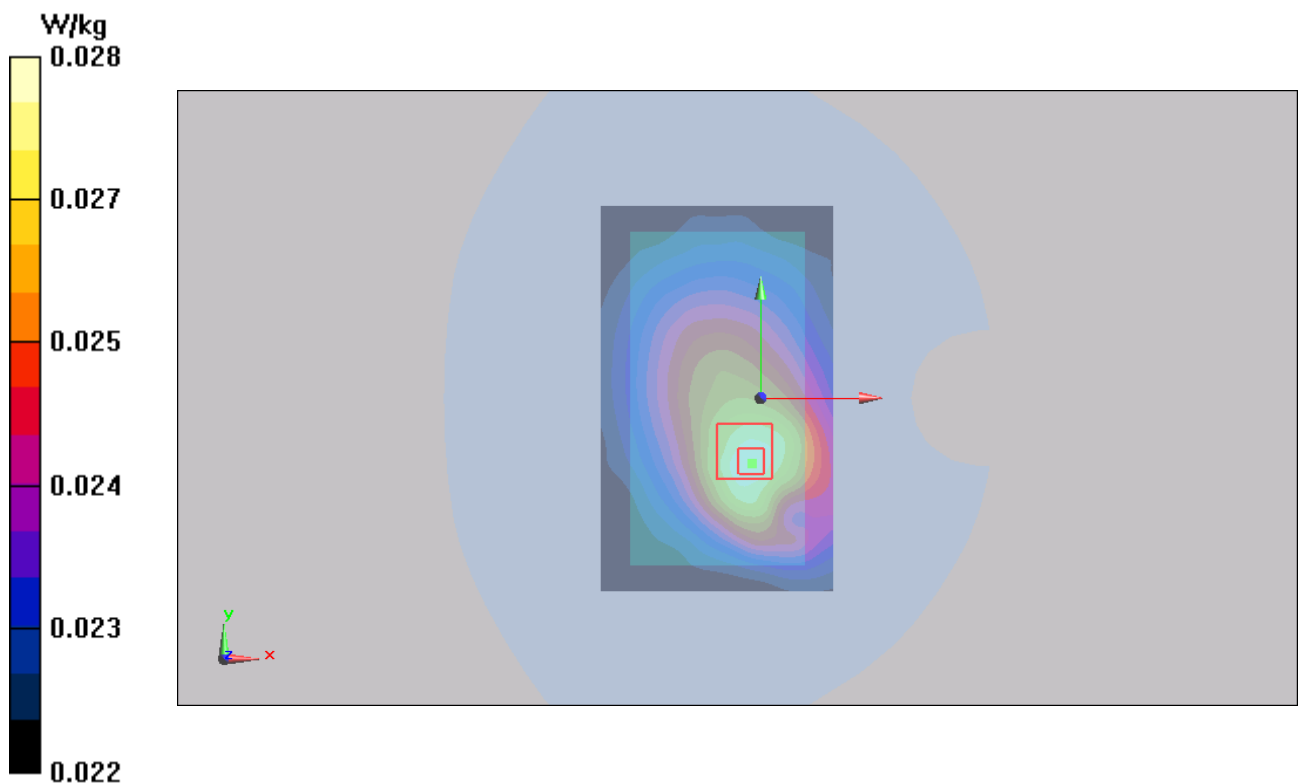

Figure 96 Body, Back Side, BT Channel 0

TA Technology (Shanghai) Co., Ltd.

Test Report

Report No.: RXA1307-0093SAR01R3

Page 170 of 225

ANNEX D: Probe Calibration Certificate

**Calibration Laboratory of
Schmid & Partner
Engineering AG**
Zeughausstrasse 43, 8004 Zurich, Switzerland



S Schweizerischer Kalibrierdienst
C Service suisse d'étalonnage
S Servizio svizzero di taratura
Swiss Calibration Service

Accredited by the Swiss Accreditation Service (SAS)
The Swiss Accreditation Service is one of the signatories to the EA
Multilateral Agreement for the recognition of calibration certificates

Accreditation No.: **SCS 108**

Client **Auden**

Certificate No: **EX3-3753_Jan13**

CALIBRATION CERTIFICATE

Object **EX3DV4 - SN:3753**

Calibration procedure(s) **QA CAL-01.v8, QA CAL-14.v3, QA CAL-23.v4, QA CAL-25.v4
Calibration procedure for dosimetric E-field probes**

Calibration date: **January 17, 2013**

This calibration certificate documents the traceability to national standards, which realize the physical units of measurements (SI).
The measurements and the uncertainties with confidence probability are given on the following pages and are part of the certificate.

All calibrations have been conducted in the closed laboratory facility: environment temperature (22 ± 3)°C and humidity < 70%.

Calibration Equipment used (M&TE critical for calibration)

Primary Standards	ID	Cal Date (Certificate No.)	Scheduled Calibration
Power meter E4419B	GB41293874	29-Mar-12 (No. 217-01508)	Apr-13
Power sensor E4412A	MY41498087	29-Mar-12 (No. 217-01508)	Apr-13
Reference 3 dB Attenuator	SN: S5054 (3c)	27-Mar-12 (No. 217-01531)	Apr-13
Reference 20 dB Attenuator	SN: S5098 (20b)	27-Mar-12 (No. 217-01529)	Apr-13
Reference 30 dB Attenuator	SN: S5129 (30b)	27-Mar-12 (No. 217-01532)	Apr-13
Reference Probe ES3DV2	SN: 3013	28-Dec-12 (No. ES3-3013_Dec12)	Dec-13
DAE4	SN: 660	20-Jun-12 (No. DAE4-660_Jun12)	Jun-13
Secondary Standards	ID	Check Date (in house)	Scheduled Check
RF generator HP 8649C	US3642U01700	4-Aug-99 (in house check Apr-11)	In house check: Apr-13
Network Analyzer HP 8753E	US37390585	18-Oct-01 (in house check Oct-12)	In house check: Oct-13

	Name	Function	Signature
Calibrated by:	Jeton Kastrati	Laboratory Technician	
Approved by:	Katja Pokovic	Technical Manager	

Issued: January 17, 2013

This calibration certificate shall not be reproduced except in full without written approval of the laboratory.

TA Technology (Shanghai) Co., Ltd.

Test Report

Report No.: RXA1307-0093SAR01R3

Page 171 of 225

Calibration Laboratory of
Schmid & Partner
Engineering AG
Zeughausstrasse 43, 8004 Zurich, Switzerland



S Schweizerischer Kalibrierdienst
C Service suisse d'étalonnage
S Servizio svizzero di taratura
S Swiss Calibration Service

Accredited by the Swiss Accreditation Service (SAS)

Accreditation No.: **SCS 108**

The Swiss Accreditation Service is one of the signatories to the EA
Multilateral Agreement for the recognition of calibration certificates

Glossary:

TSL	tissue simulating liquid
NORM _{x,y,z}	sensitivity in free space
ConvF	sensitivity in TSL / NORM _{x,y,z}
DCP	diode compression point
CF	crest factor (1/duty_cycle) of the RF signal
A, B, C, D	modulation dependent linearization parameters
Polarization φ	φ rotation around probe axis
Polarization ϑ	ϑ rotation around an axis that is in the plane normal to probe axis (at measurement center), i.e., $\vartheta = 0$ is normal to probe axis

Calibration is Performed According to the Following Standards:

- IEEE Std 1528-2003, "IEEE Recommended Practice for Determining the Peak Spatial-Averaged Specific Absorption Rate (SAR) in the Human Head from Wireless Communications Devices: Measurement Techniques", December 2003
- IEC 62209-1, "Procedure to measure the Specific Absorption Rate (SAR) for hand-held devices used in close proximity to the ear (frequency range of 300 MHz to 3 GHz)", February 2005

Methods Applied and Interpretation of Parameters:

- NORM_{x,y,z}**: Assessed for E-field polarization $\vartheta = 0$ ($f \leq 900$ MHz in TEM-cell; $f > 1800$ MHz: R22 waveguide). NORM_{x,y,z} are only intermediate values, i.e., the uncertainties of NORM_{x,y,z} does not affect the E²-field uncertainty inside TSL (see below ConvF).
- NORM(f)_{x,y,z}** = NORM_{x,y,z} * frequency_response (see Frequency Response Chart). This linearization is implemented in DASY4 software versions later than 4.2. The uncertainty of the frequency response is included in the stated uncertainty of ConvF.
- DCP_{x,y,z}**: DCP are numerical linearization parameters assessed based on the data of power sweep with CW signal (no uncertainty required). DCP does not depend on frequency nor media.
- PAR**: PAR is the Peak to Average Ratio that is not calibrated but determined based on the signal characteristics
- A_{x,y,z}; B_{x,y,z}; C_{x,y,z}; D_{x,y,z}; VR_{x,y,z}**: A, B, C, D are numerical linearization parameters assessed based on the data of power sweep for specific modulation signal. The parameters do not depend on frequency nor media. VR is the maximum calibration range expressed in RMS voltage across the diode.
- ConvF and Boundary Effect Parameters**: Assessed in flat phantom using E-field (or Temperature Transfer Standard for $f \leq 800$ MHz) and inside waveguide using analytical field distributions based on power measurements for $f > 800$ MHz. The same setups are used for assessment of the parameters applied for boundary compensation (alpha, depth) of which typical uncertainty values are given. These parameters are used in DASY4 software to improve probe accuracy close to the boundary. The sensitivity in TSL corresponds to NORM_{x,y,z} * ConvF whereby the uncertainty corresponds to that given for ConvF. A frequency dependent ConvF is used in DASY version 4.4 and higher which allows extending the validity from ± 50 MHz to ± 100 MHz.
- Spherical isotropy (3D deviation from isotropy)**: in a field of low gradients realized using a flat phantom exposed by a patch antenna.
- Sensor Offset**: The sensor offset corresponds to the offset of virtual measurement center from the probe tip (on probe axis). No tolerance required.

EX3DV4 – SN:3753

January 17, 2013

Probe EX3DV4

SN:3753

Manufactured: March 16, 2010
Calibrated: January 17, 2013

Calibrated for DASY/EASY Systems
(Note: non-compatible with DASY2 system!)

TA Technology (Shanghai) Co., Ltd.

Test Report

EX3DV4- SN:3753

January 17, 2013

DASY/EASY - Parameters of Probe: EX3DV4 - SN:3753

Basic Calibration Parameters

	Sensor X	Sensor Y	Sensor Z	Unc (k=2)
Norm ($\mu\text{V}/(\text{V}/\text{m})^2$) ^A	0.47	0.31	0.45	± 10.1 %
DCP (mV) ^B	101.8	102.3	102.3	

Modulation Calibration Parameters

UID	Communication System Name		A dB	B dB√ μV	C	D dB	VR mV	Unc ^E (k=2)
0	CW	X	0.0	0.0	1.0	0.00	163.7	±3.5 %
		Y	0.0	0.0	1.0		168.5	
		Z	0.0	0.0	1.0		159.9	

The reported uncertainty of measurement is stated as the standard uncertainty of measurement multiplied by the coverage factor k=2, which for a normal distribution corresponds to a coverage probability of approximately 95%.

^A The uncertainties of NormX,Y,Z do not affect the E²-field uncertainty inside TSL (see Pages 5 and 6).

^B Numerical linearization parameter: uncertainty not required.

^E Uncertainty is determined using the max. deviation from linear response applying rectangular distribution and is expressed for the square of the field value.

TA Technology (Shanghai) Co., Ltd.

Test Report

EX3DV4- SN:3753

January 17, 2013

DASY/EASY - Parameters of Probe: EX3DV4 - SN:3753

Calibration Parameter Determined in Head Tissue Simulating Media

f (MHz) ^C	Relative Permittivity ^F	Conductivity (S/m) ^F	ConvF X	ConvF Y	ConvF Z	Alpha	Depth (mm)	Unct. (k=2)
750	41.9	0.89	9.46	9.46	9.46	0.45	0.83	± 12.0 %
835	41.5	0.90	8.95	8.95	8.95	0.26	1.19	± 12.0 %
1750	40.1	1.37	7.86	7.86	7.86	0.52	0.79	± 12.0 %
1900	40.0	1.40	7.63	7.63	7.63	0.54	0.73	± 12.0 %
2000	40.0	1.40	7.50	7.50	7.50	0.53	0.77	± 12.0 %
2450	39.2	1.80	6.86	6.86	6.86	0.44	0.80	± 12.0 %
5200	36.0	4.66	4.65	4.65	4.65	0.40	1.80	± 13.1 %
5300	35.9	4.76	4.48	4.48	4.48	0.40	1.80	± 13.1 %
5500	35.6	4.96	4.46	4.46	4.46	0.40	1.80	± 13.1 %
5600	35.5	5.07	4.51	4.51	4.51	0.35	1.80	± 13.1 %
5800	35.3	5.27	4.36	4.36	4.36	0.45	1.80	± 13.1 %

^C Frequency validity of ± 100 MHz only applies for DASY v4.4 and higher (see Page 2), else it is restricted to ± 50 MHz. The uncertainty is the RSS of the ConvF uncertainty at calibration frequency and the uncertainty for the indicated frequency band.

^F At frequencies below 3 GHz, the validity of tissue parameters (ϵ and σ) can be relaxed to ± 10% if liquid compensation formula is applied to measured SAR values. At frequencies above 3 GHz, the validity of tissue parameters (ϵ and σ) is restricted to ± 5%. The uncertainty is the RSS of the ConvF uncertainty for indicated target tissue parameters.

TA Technology (Shanghai) Co., Ltd.

Test Report

Report No.: RXA1307-0093SAR01R3

Page 175 of 225

EX3DV4- SN:3753

January 17, 2013

DASY/EASY - Parameters of Probe: EX3DV4 - SN:3753

Calibration Parameter Determined in Body Tissue Simulating Media

f (MHz) ^c	Relative Permittivity ^f	Conductivity (S/m) ^f	ConvF X	ConvF Y	ConvF Z	Alpha	Depth (mm)	Unct. (k=2)
750	55.5	0.96	9.25	9.25	9.25	0.54	0.75	± 12.0 %
835	55.2	0.97	9.05	9.05	9.05	0.68	0.68	± 12.0 %
1750	53.4	1.49	7.82	7.82	7.82	0.50	0.84	± 12.0 %
1900	53.3	1.52	7.33	7.33	7.33	0.31	1.01	± 12.0 %
2000	53.3	1.52	7.43	7.43	7.43	0.57	0.73	± 12.0 %
2300	52.9	1.81	7.07	7.07	7.07	0.74	0.64	± 12.0 %
2450	52.7	1.95	6.90	6.90	6.90	0.80	0.50	± 12.0 %
2600	52.5	2.16	6.66	6.66	6.66	0.80	0.50	± 12.0 %
3500	51.3	3.31	6.30	6.30	6.30	0.38	1.11	± 13.1 %
5200	49.0	5.30	4.38	4.38	4.38	0.50	1.90	± 13.1 %
5300	48.9	5.42	4.13	4.13	4.13	0.50	1.90	± 13.1 %
5500	48.6	5.65	4.09	4.09	4.09	0.50	1.90	± 13.1 %
5600	48.5	5.77	4.10	4.10	4.10	0.45	1.90	± 13.1 %
5800	48.2	6.00	4.02	4.02	4.02	0.55	1.90	± 13.1 %

^c Frequency validity of ± 100 MHz only applies for DASY v4.4 and higher (see Page 2), else it is restricted to ± 50 MHz. The uncertainty is the RSS of the ConvF uncertainty at calibration frequency and the uncertainty for the indicated frequency band.

^f At frequencies below 3 GHz, the validity of tissue parameters (ϵ and σ) can be relaxed to ± 10% if liquid compensation formula is applied to measured SAR values. At frequencies above 3 GHz, the validity of tissue parameters (ϵ and σ) is restricted to ± 5%. The uncertainty is the RSS of the ConvF uncertainty for indicated target tissue parameters.

EX3DV4-SN:3753

January 17, 2013

Frequency Response of E-Field
(TEM-Cell:ifi110 EXX, Waveguide: R22)

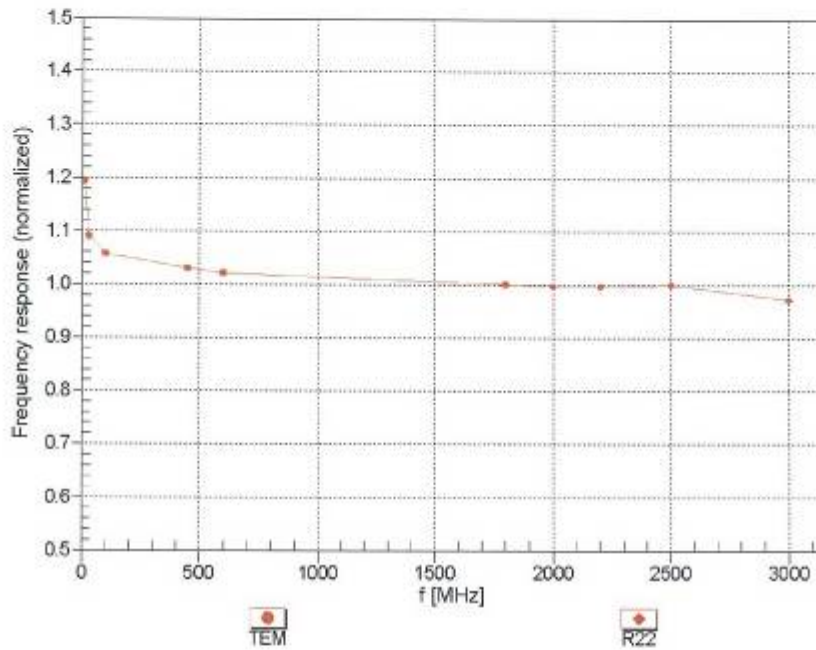

Uncertainty of Frequency Response of E-field: $\pm 6.3\%$ (k=2)

EX3DV4- SN:3753

January 17, 2013

Receiving Pattern (ϕ), $\theta = 0^\circ$

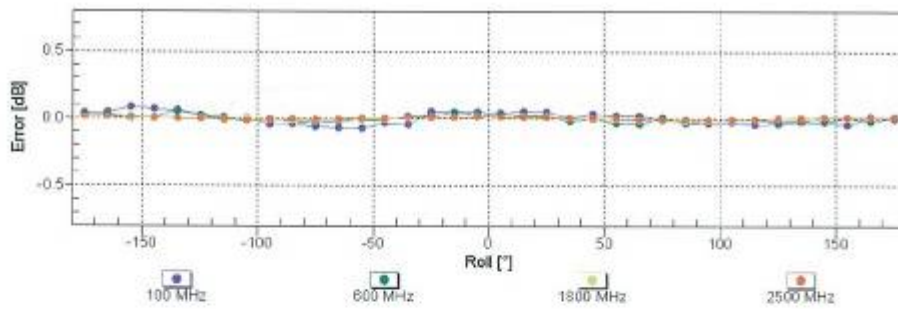
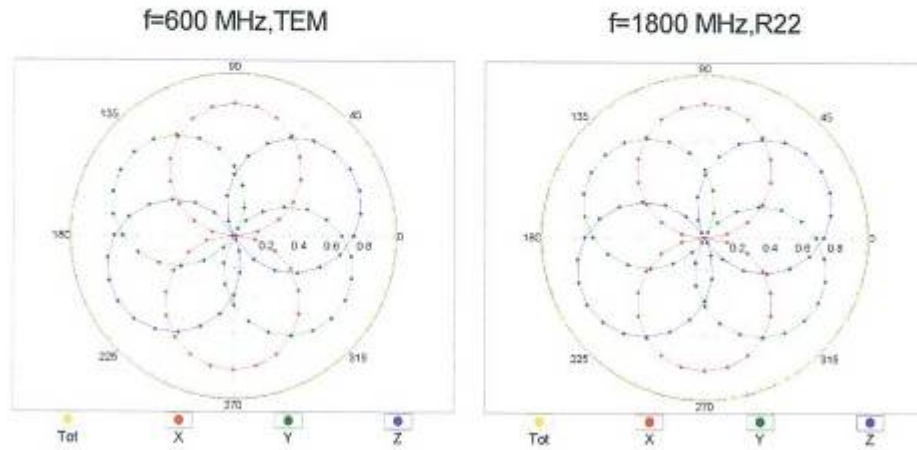

Uncertainty of Axial Isotropy Assessment: $\pm 0.5\%$ (k=2)

TA Technology (Shanghai) Co., Ltd. Test Report

Report No.: RXA1307-0093SAR01R3

Page 178 of 225

EX3DV4- SN:3753

January 17, 2013

Dynamic Range $f(\text{SAR}_{\text{head}})$ (TEM cell, $f = 900 \text{ MHz}$)

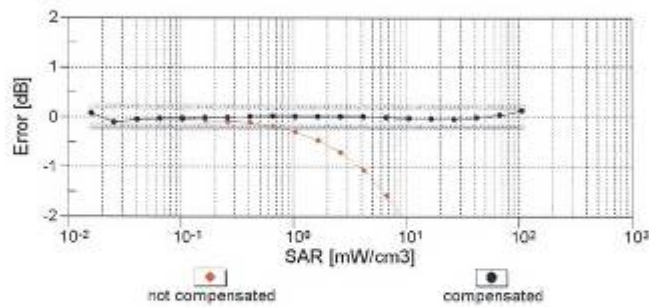
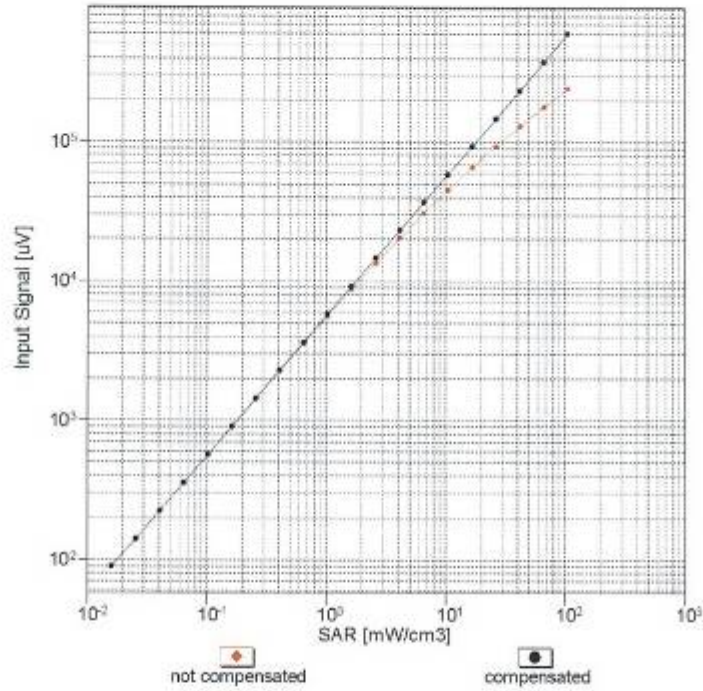

Uncertainty of Linearity Assessment: $\pm 0.6\%$ ($k=2$)

EX3DV4- SN:3753

January 17, 2013

Conversion Factor Assessment

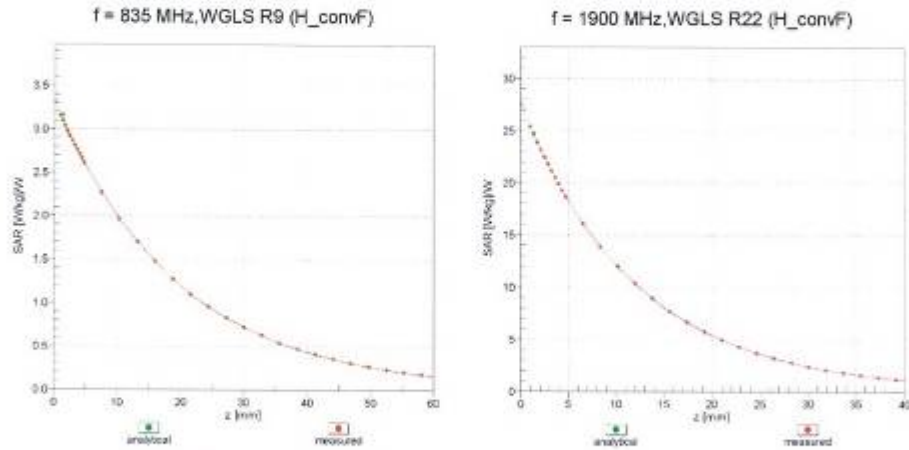

Deviation from Isotropy in Liquid Error (ϕ , θ), f = 900 MHz

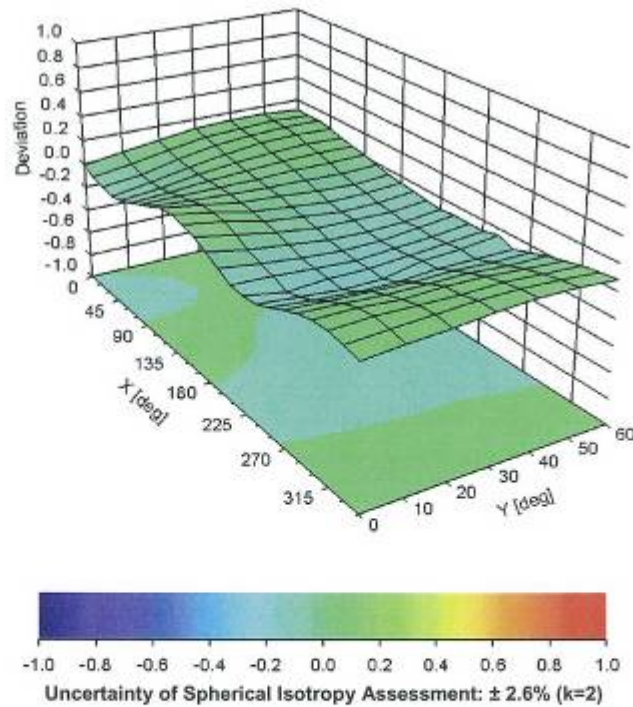

TA Technology (Shanghai) Co., Ltd.
Test Report

Report No.: RXA1307-0093SAR01R3

Page 180 of 225

EX3DV4- SN:3753

January 17, 2013

DASY/EASY - Parameters of Probe: EX3DV4 - SN:3753

Other Probe Parameters

Sensor Arrangement	Triangular
Connector Angle (°)	55.2
Mechanical Surface Detection Mode	enabled
Optical Surface Detection Mode	disabled
Probe Overall Length	337 mm
Probe Body Diameter	10 mm
Tip Length	9 mm
Tip Diameter	2.5 mm
Probe Tip to Sensor X Calibration Point	1 mm
Probe Tip to Sensor Y Calibration Point	1 mm
Probe Tip to Sensor Z Calibration Point	1 mm
Recommended Measurement Distance from Surface	2 mm

TA Technology (Shanghai) Co., Ltd.

Test Report

Report No.: RXA1307-0093SAR01R3

Page 181 of 225

ANNEX E: D835V2 Dipole Calibration Certificate

**Calibration Laboratory of
Schmid & Partner
Engineering AG**
Zeughausstrasse 43, 8004 Zurich, Switzerland



S Schweizerischer Kalibrierdienst
C Service suisse d'étalonnage
S Servizio svizzero di taratura
S Swiss Calibration Service

Accredited by the Swiss Accreditation Service (SAS)
The Swiss Accreditation Service is one of the signatories to the EA
Multilateral Agreement for the recognition of calibration certificates

Accreditation No.: **SCS 108**

Client **TA-Shanghai (Auden)**

Certificate No: **D835V2-4d020_Aug11**

CALIBRATION CERTIFICATE

Object: **D835V2 - SN: 4d020**

Calibration procedure(s): **QA CAL-05.v8
Calibration procedure for dipole validation kits above 700 MHz**

Calibration date: **August 26, 2011**

This calibration certificate documents the traceability to national standards, which realize the physical units of measurements (SI). The measurements and the uncertainties with confidence probability are given on the following pages and are part of the certificate.

All calibrations have been conducted in the closed laboratory facility: environment temperature (22 ± 3)°C and humidity < 70%.

Calibration Equipment used (M&TE critical for calibration)

Primary Standards	ID #	Cal Date (Certificate No.)	Scheduled Calibration
Power meter EPM-442A	GB37480704	06-Oct-10 (No. 217-01266)	Oct-11
Power sensor HP 8481A	US37292783	06-Oct-10 (No. 217-01266)	Oct-11
Reference 20 dB Attenuator	SN: S5086 (20b)	29-Mar-11 (No. 217-01367)	Apr-12
Type-N mismatch combination	SN: 5047.2 / 06327	29-Mar-11 (No. 217-01371)	Apr-12
Reference Probe ES3DV3	SN: 3205	29-Apr-11 (No. ES3-3205_Apr11)	Apr-12
DAE4	SN: 601	04-Jul-11 (No. DAE4-601_Jul11)	Jul-12
Secondary Standards	ID #	Check Date (in house)	Scheduled Check
Power sensor HP 8481A	MY41092317	18-Oct-02 (in house check Oct-09)	In house check: Oct-11
RF generator R&S SMT-06	100006	04-Aug-99 (in house check Oct-09)	In house check: Oct-11
Network Analyzer HP 8753E	US37390585 S4206	18-Oct-01 (in house check Oct-10)	In house check: Oct-11

	Name	Function	Signature
Calibrated by:	Jeton Kastrati	Laboratory Technician	
Approved by:	Katja Pokovic	Technical Manager	

Issued: August 26, 2011

This calibration certificate shall not be reproduced except in full without written approval of the laboratory.

TA Technology (Shanghai) Co., Ltd.

Test Report

Report No.: RXA1307-0093SAR01R3

Page 182 of 225

**Calibration Laboratory of
Schmid & Partner
Engineering AG**
Zeughausstrasse 43, 8004 Zurich, Switzerland



S Schweizerischer Kalibrierdienst
C Service suisse d'étalonnage
S Servizio svizzero di taratura
S Swiss Calibration Service

Accredited by the Swiss Accreditation Service (SAS)

The Swiss Accreditation Service is one of the signatories to the EA
Multilateral Agreement for the recognition of calibration certificates

Accreditation No.: **SCS 108**

Glossary:

TSL	tissue simulating liquid
ConvF	sensitivity in TSL / NORM x,y,z
N/A	not applicable or not measured

Calibration is Performed According to the Following Standards:

- IEEE Std 1528-2003, "IEEE Recommended Practice for Determining the Peak Spatial-Averaged Specific Absorption Rate (SAR) in the Human Head from Wireless Communications Devices: Measurement Techniques", December 2003
- IEC 62209-1, "Procedure to measure the Specific Absorption Rate (SAR) for hand-held devices used in close proximity to the ear (frequency range of 300 MHz to 3 GHz)", February 2005
- Federal Communications Commission Office of Engineering & Technology (FCC OET), "Evaluating Compliance with FCC Guidelines for Human Exposure to Radiofrequency Electromagnetic Fields; Additional Information for Evaluating Compliance of Mobile and Portable Devices with FCC Limits for Human Exposure to Radiofrequency Emissions", Supplement C (Edition 01-01) to Bulletin 65

Additional Documentation:

- DASY4/5 System Handbook

Methods Applied and Interpretation of Parameters:

- Measurement Conditions:** Further details are available from the Validation Report at the end of the certificate. All figures stated in the certificate are valid at the frequency indicated.
- Antenna Parameters with TSL:** The dipole is mounted with the spacer to position its feed point exactly below the center marking of the flat phantom section, with the arms oriented parallel to the body axis.
- Feed Point Impedance and Return Loss:** These parameters are measured with the dipole positioned under the liquid filled phantom. The impedance stated is transformed from the measurement at the SMA connector to the feed point. The Return Loss ensures low reflected power. No uncertainty required.
- Electrical Delay:** One-way delay between the SMA connector and the antenna feed point. No uncertainty required.
- SAR measured:** SAR measured at the stated antenna input power.
- SAR normalized:** SAR as measured, normalized to an input power of 1 W at the antenna connector.
- SAR for nominal TSL parameters:** The measured TSL parameters are used to calculate the nominal SAR result.

TA Technology (Shanghai) Co., Ltd.

Test Report

Measurement Conditions

DASY system configuration, as far as not given on page 1.

DASY Version	DASY5	V52.6.2
Extrapolation	Advanced Extrapolation	
Phantom	Modular Flat Phantom	
Distance Dipole Center - TSL	15 mm	with Spacer
Zoom Scan Resolution	dx, dy, dz = 5 mm	
Frequency	835 MHz ± 1 MHz	

Head TSL parameters

The following parameters and calculations were applied.

	Temperature	Permittivity	Conductivity
Nominal Head TSL parameters	22.0 °C	41.5	0.90 mho/m
Measured Head TSL parameters	(22.0 ± 0.2) °C	41.1 ± 6 %	0.89 mho/m ± 6 %
Head TSL temperature change during test	< 0.5 °C	----	----

SAR result with Head TSL

SAR averaged over 1 cm ³ (1 g) of Head TSL	Condition	
SAR measured	250 mW input power	2.32 mW / g
SAR for nominal Head TSL parameters	normalized to 1W	9.34 mW / g ± 17.0 % (k=2)

SAR averaged over 10 cm ³ (10 g) of Head TSL	condition	
SAR measured	250 mW input power	1.52 mW / g
SAR for nominal Head TSL parameters	normalized to 1W	6.11 mW / g ± 16.5 % (k=2)

Body TSL parameters

The following parameters and calculations were applied.

	Temperature	Permittivity	Conductivity
Nominal Body TSL parameters	22.0 °C	55.2	0.97 mho/m
Measured Body TSL parameters	(22.0 ± 0.2) °C	53.4 ± 6 %	0.99 mho/m ± 6 %
Body TSL temperature change during test	< 0.5 °C	----	----

SAR result with Body TSL

SAR averaged over 1 cm ³ (1 g) of Body TSL	Condition	
SAR measured	250 mW input power	2.42 mW / g
SAR for nominal Body TSL parameters	normalized to 1W	9.46 mW / g ± 17.0 % (k=2)

SAR averaged over 10 cm ³ (10 g) of Body TSL	condition	
SAR measured	250 mW input power	1.59 mW / g
SAR for nominal Body TSL parameters	normalized to 1W	6.26 mW / g ± 16.5 % (k=2)

TA Technology (Shanghai) Co., Ltd.

Test Report

Report No.: RXA1307-0093SAR01R3

Page 184 of 225

Appendix

Antenna Parameters with Head TSL

Impedance, transformed to feed point	52.9 Ω - 3.1 $j\Omega$
Return Loss	- 27.7 dB

Antenna Parameters with Body TSL

Impedance, transformed to feed point	48.7 Ω - 5.4 $j\Omega$
Return Loss	- 25.1 dB

General Antenna Parameters and Design

Electrical Delay (one direction)	1.391 ns
----------------------------------	----------

After long term use with 100W radiated power, only a slight warming of the dipole near the feedpoint can be measured.

The dipole is made of standard semirigid coaxial cable. The center conductor of the feeding line is directly connected to the second arm of the dipole. The antenna is therefore short-circuited for DC-signals.

No excessive force must be applied to the dipole arms, because they might bend or the soldered connections near the feedpoint may be damaged.

Additional EUT Data

Manufactured by	SPEAG
Manufactured on	April 22, 2004

DASY5 Validation Report for Head TSL

Date: 25.08.2011

Test Laboratory: SPEAG, Zurich, Switzerland

DUT: Dipole 835 MHz; Type: D835V2; Serial: D835V2 - SN: 4d020

Communication System: CW; Frequency: 835 MHz

Medium parameters used: $f = 835$ MHz; $\sigma = 0.89$ mho/m; $\epsilon_r = 41.1$; $\rho = 1000$ kg/m³

Phantom section: Flat Section

Measurement Standard: DASY5 (IEEE/IEC/ANSI C63.19-2007)

DASY52 Configuration:

- Probe: ES3DV3 - SN3205; ConvF(6.07, 6.07, 6.07); Calibrated: 29.04.2011
- Sensor-Surface: 3mm (Mechanical Surface Detection)
- Electronics: DAE4 Sn601; Calibrated: 04.07.2011
- Phantom: Flat Phantom 4.9L; Type: QD000P49AA; Serial: 1001
- DASY52 52.6.2(482); SEMCAD X 14.4.5(3634)

Dipole Calibration for Head Tissue/Pin=250 mW, d=15mm/Zoom Scan (7x7x7)/Cube 0:

Measurement grid: dx=5mm, dy=5mm, dz=5mm

Reference Value = 56.930 V/m; Power Drift = 0.03 dB

Peak SAR (extrapolated) = 3.421 W/kg

SAR(1 g) = 2.32 mW/g; SAR(10 g) = 1.52 mW/g

Maximum value of SAR (measured) = 2.708 mW/g

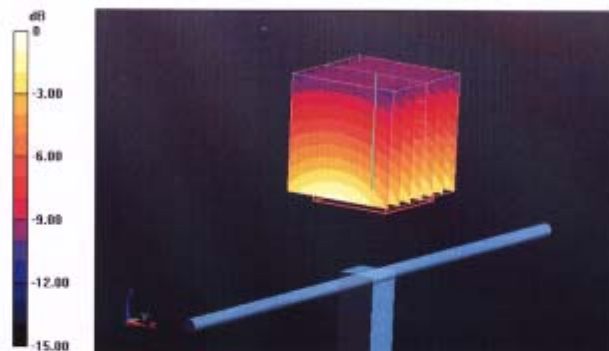

0 dB = 2.710mW/g

TA Technology (Shanghai) Co., Ltd. Test Report

Report No.: RXA1307-0093SAR01R3

Page 186 of 225

Impedance Measurement Plot for Head TSL

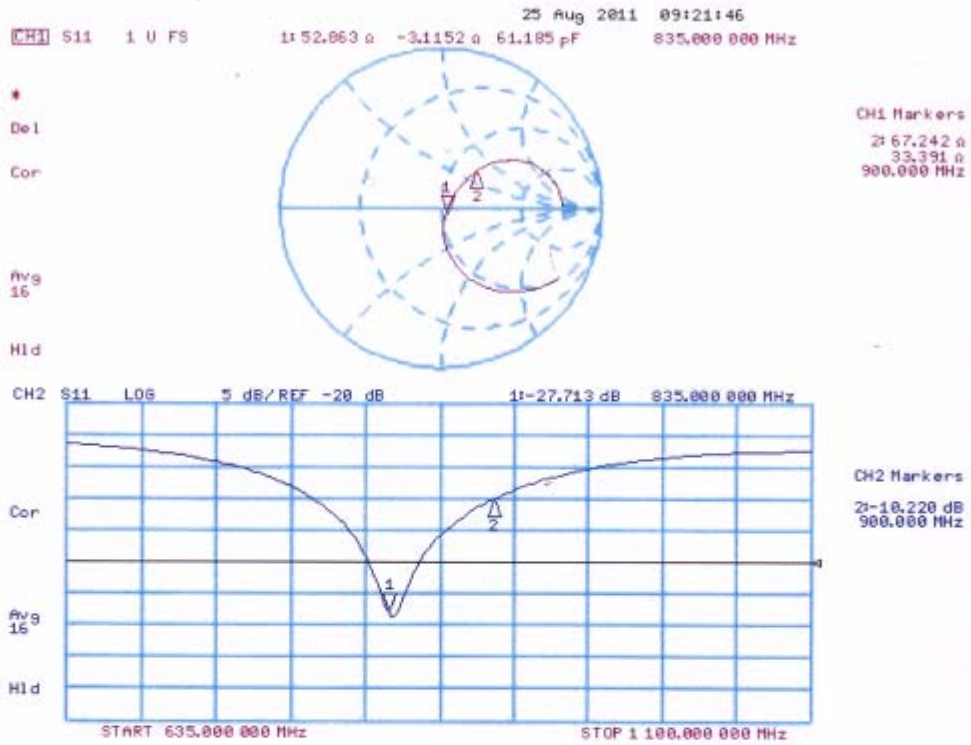

DASY5 Validation Report for Body TSL

Date: 26.08.2011

Test Laboratory: SPEAG, Zurich, Switzerland

DUT: Dipole 835 MHz; Type: D835V2; Serial: D835V2 - SN: 4d020

Communication System: CW; Frequency: 835 MHz

Medium parameters used: $f = 835$ MHz; $\sigma = 0.99$ mho/m; $\epsilon_r = 53.4$; $\rho = 1000$ kg/m³

Phantom section: Flat Section

Measurement Standard: DASY5 (IEEE/IEC/ANSI C63.19-2007)

DASY52 Configuration:

- Probe: ES3DV3 - SN3205; ConvF(6.02, 6.02, 6.02); Calibrated: 29.04.2011
- Sensor-Surface: 3mm (Mechanical Surface Detection)
- Electronics: DAE4 Sn601; Calibrated: 04.07.2011
- Phantom: Flat Phantom 4.9L; Type: QD000P49AA; Serial: 1001
- DASY52 52.6.2(482); SEMCAD X 14.4.5(3634)

Dipole Calibration for Body Tissue/Pin=250 mW, d=15mm/Zoom Scan (7x7x7)/Cube 0:

Measurement grid: dx=5mm, dy=5mm, dz=5mm

Reference Value = 55.406 V/m; Power Drift = 0.02 dB

Peak SAR (extrapolated) = 3.509 W/kg

SAR(1 g) = 2.42 mW/g; SAR(10 g) = 1.59 mW/g

Maximum value of SAR (measured) = 2.827 mW/g

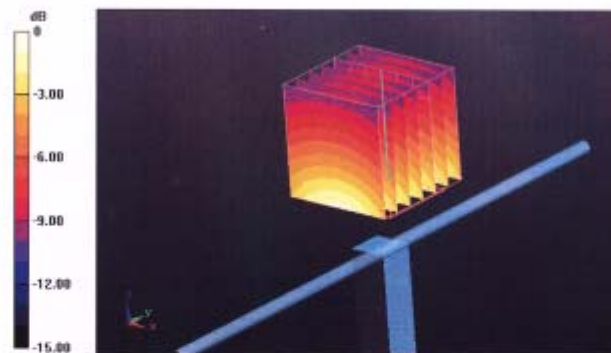

0 dB = 2.830mW/g

Impedance Measurement Plot for Body TSL

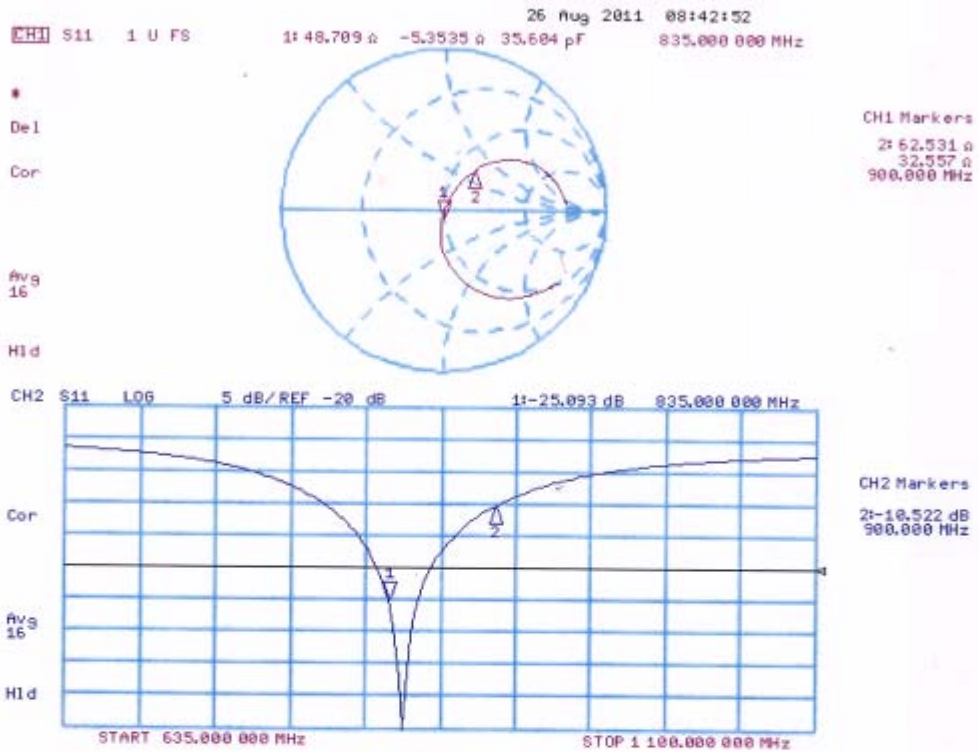

TA Technology (Shanghai) Co., Ltd. Test Report

Report No.: RXA1307-0093SAR01R3

Page 189 of 225

ANNEX F: D1750V2 Dipole Calibration Certificate

**Calibration Laboratory of
Schmid & Partner
Engineering AG**
Zeughausstrasse 43, 8004 Zurich, Switzerland



S Schweizerischer Kalibrierdienst
C Service suisse d'étalonnage
S Servizio svizzero di taratura
S Swiss Calibration Service

Accredited by the Swiss Accreditation Service (SAS)
The Swiss Accreditation Service is one of the signatories to the EA
Multilateral Agreement for the recognition of calibration certificates

Accreditation No.: **SCS 108**

Client **Auden**

Certificate No: **D1750V2-1023_Jun12**

CALIBRATION CERTIFICATE

Object **D1750V2 - SN: 1023**

Calibration procedure(s) **QA CAL-05.v8
Calibration procedure for dipole validation kits above 700 MHz**

Calibration date: **June 20, 2012**

This calibration certificate documents the traceability to national standards, which realize the physical units of measurements (SI).
The measurements and the uncertainties with confidence probability are given on the following pages and are part of the certificate.

All calibrations have been conducted in the closed laboratory facility: environment temperature (22 ± 3)°C and humidity < 70%.

Calibration Equipment used (M&TE critical for calibration)

Primary Standards	ID #	Cal Date (Certificate No.)	Scheduled Calibration
Power meter EPM-442A	GB37480704	05-Oct-11 (No. 217-01451)	Oct-12
Power sensor HP B481A	US37292783	05-Oct-11 (No. 217-01451)	Oct-12
Reference 20 dB Attenuator	SN: 5058 (20k)	27-Mar-12 (No. 217-01530)	Apr-13
Type-N mismatch combination	SN: 5047.2 / 06327	27-Mar-12 (No. 217-01533)	Apr-13
Reference Probe ES3DV3	SN: 3205	30-Dec-11 (No. ES3-3205_Dec11)	Dec-12
DAE4	SN: 601	04-Jul-11 (No. DAE4-601_Jul11)	Jul-12
Secondary Standards	ID #	Check Date (in house)	Scheduled Check
Power sensor HP B481A	MY41092317	18-Oct-02 (in house check Oct-11)	In house check: Oct-13
RF generator R&S SMT-06	100005	04-Aug-99 (in house check Oct-11)	In house check: Oct-13
Network Analyzer HP 8753E	US37390585 S4206	18-Oct-01 (in house check Oct-11)	In house check: Oct-12

	Name	Function	Signature
Calibrated by:	Israa El-Naouq	Laboratory Technician	
Approved by:	Katja Pokovic	Technical Manager	

Issued: June 20, 2012

This calibration certificate shall not be reproduced except in full without written approval of the laboratory.

TA Technology (Shanghai) Co., Ltd.

Test Report

Report No.: RXA1307-0093SAR01R3

Page 190 of 225

**Calibration Laboratory of
Schmid & Partner
Engineering AG**
Zeughausstrasse 43, 8004 Zurich, Switzerland



S Schweizerischer Kalibrierdienst
S Service suisse d'étalonnage
C Servizio svizzero di taratura
S Swiss Calibration Service

Accredited by the Swiss Accreditation Service (SAS)

The Swiss Accreditation Service is one of the signatories to the EA
Multilateral Agreement for the recognition of calibration certificates

Accreditation No.: **SCS 108**

Glossary:

TSL	tissue simulating liquid
ConvF	sensitivity in TSL / NORM x,y,z
N/A	not applicable or not measured

Calibration is Performed According to the Following Standards:

- IEEE Std 1528-2003, "IEEE Recommended Practice for Determining the Peak Spatial-Averaged Specific Absorption Rate (SAR) in the Human Head from Wireless Communications Devices: Measurement Techniques", December 2003
- IEC 62209-1, "Procedure to measure the Specific Absorption Rate (SAR) for hand-held devices used in close proximity to the ear (frequency range of 300 MHz to 3 GHz)", February 2005
- Federal Communications Commission Office of Engineering & Technology (FCC OET), "Evaluating Compliance with FCC Guidelines for Human Exposure to Radiofrequency Electromagnetic Fields; Additional Information for Evaluating Compliance of Mobile and Portable Devices with FCC Limits for Human Exposure to Radiofrequency Emissions", Supplement C (Edition 01-01) to Bulletin 65

Additional Documentation:

- DASY4/5 System Handbook

Methods Applied and Interpretation of Parameters:

- Measurement Conditions:* Further details are available from the Validation Report at the end of the certificate. All figures stated in the certificate are valid at the frequency indicated.
- Antenna Parameters with TSL:* The dipole is mounted with the spacer to position its feed point exactly below the center marking of the flat phantom section, with the arms oriented parallel to the body axis.
- Feed Point Impedance and Return Loss:* These parameters are measured with the dipole positioned under the liquid filled phantom. The impedance stated is transformed from the measurement at the SMA connector to the feed point. The Return Loss ensures low reflected power. No uncertainty required.
- Electrical Delay:* One-way delay between the SMA connector and the antenna feed point. No uncertainty required.
- SAR measured:* SAR measured at the stated antenna input power.
- SAR normalized:* SAR as measured, normalized to an input power of 1 W at the antenna connector.
- SAR for nominal TSL parameters:* The measured TSL parameters are used to calculate the nominal SAR result.

The reported uncertainty of measurement is stated as the standard uncertainty of measurement multiplied by the coverage factor $k=2$, which for a normal distribution corresponds to a coverage probability of approximately 95%.

TA Technology (Shanghai) Co., Ltd.

Test Report

Measurement Conditions

DASY system configuration, as far as not given on page 1.

DASY Version	DASY5	V52.8.1
Extrapolation	Advanced Extrapolation	
Phantom	Modular Flat Phantom	
Distance Dipole Center - TSL	10 mm	with Spacer
Zoom Scan Resolution	dx, dy, dz = 5 mm	
Frequency	1750 MHz ± 1 MHz	

Head TSL parameters

The following parameters and calculations were applied.

	Temperature	Permittivity	Conductivity
Nominal Head TSL parameters	22.0 °C	40.1	1.37 mho/m
Measured Head TSL parameters	(22.0 ± 0.2) °C	40.1 ± 6 %	1.35 mho/m ± 6 %
Head TSL temperature change during test	< 0.5 °C	----	----

SAR result with Head TSL

SAR averaged over 1 cm ³ (1 g) of Head TSL	Condition	
SAR measured	250 mW input power	8.87 mW / g
SAR for nominal Head TSL parameters	normalized to 1W	35.8 mW / g ± 17.0 % (k=2)

SAR averaged over 10 cm ³ (10 g) of Head TSL	condition	
SAR measured	250 mW input power	4.76 mW / g
SAR for nominal Head TSL parameters	normalized to 1W	19.2 mW / g ± 16.5 % (k=2)

Body TSL parameters

The following parameters and calculations were applied.

	Temperature	Permittivity	Conductivity
Nominal Body TSL parameters	22.0 °C	53.4	1.49 mho/m
Measured Body TSL parameters	(22.0 ± 0.2) °C	52.5 ± 6 %	1.47 mho/m ± 6 %
Body TSL temperature change during test	< 0.5 °C	----	----

SAR result with Body TSL

SAR averaged over 1 cm ³ (1 g) of Body TSL	Condition	
SAR measured	250 mW input power	9.22 mW / g
SAR for nominal Body TSL parameters	normalized to 1W	37.0 mW / g ± 17.0 % (k=2)

SAR averaged over 10 cm ³ (10 g) of Body TSL	condition	
SAR measured	250 mW input power	4.97 mW / g
SAR for nominal Body TSL parameters	normalized to 1W	19.9 mW / g ± 16.5 % (k=2)

Appendix

Antenna Parameters with Head TSL

Impedance, transformed to feed point	49.9 Ω - 0.3 $\mu\Omega$
Return Loss	- 51.7 dB

Antenna Parameters with Body TSL

Impedance, transformed to feed point	46.1 Ω + 0.2 $\mu\Omega$
Return Loss	- 27.9 dB

General Antenna Parameters and Design

Electrical Delay (one direction)	1.218 ns
----------------------------------	----------

After long term use with 100W radiated power, only a slight warming of the dipole near the feedpoint can be measured.

The dipole is made of standard semirigid coaxial cable. The center conductor of the feeding line is directly connected to the second arm of the dipole. The antenna is therefore short-circuited for DC-signals. On some of the dipoles, small end caps are added to the dipole arms in order to improve matching when loaded according to the position as explained in the "Measurement Conditions" paragraph. The SAR data are not affected by this change. The overall dipole length is still according to the Standard.

No excessive force must be applied to the dipole arms, because they might bend or the soldered connections near the feedpoint may be damaged.

Additional EUT Data

Manufactured by	SPEAG
Manufactured on	August 20, 2009

DASY5 Validation Report for Head TSL

Date: 20.06.2012

Test Laboratory: SPEAG, Zurich, Switzerland

DUT: Dipole 1750 MHz; Type: D1750V2; Serial: D1750V2 - SN: 1023

Communication System: CW; Frequency: 1750 MHz

Medium parameters used: $f = 1750$ MHz; $\sigma = 1.35$ mho/m; $\epsilon_r = 40.1$; $\rho = 1000$ kg/m³

Phantom section: Flat Section

Measurement Standard: DASY5 (IEEE/IEC/ANSI C63.19-2007)

DASY52 Configuration:

- Probe: ES3DV3 - SN3205; ConvF(5.22, 5.22, 5.22); Calibrated: 30.12.2011;
- Sensor-Surface: 3mm (Mechanical Surface Detection)
- Electronics: DAE4 Sn601; Calibrated: 04.07.2011
- Phantom: Flat Phantom 5.0 (front); Type: QD000P50AA; Serial: 1001
- DASY52 52.8.1(838); SEMCAD X 14.6.5(6469)

Dipole Calibration for Head Tissue/Pin=250 mW, d=10mm/Zoom Scan (7x7x7)/Cube 0:

Measurement grid: dx=5mm, dy=5mm, dz=5mm

Reference Value = 93.248 V/m; Power Drift = 0.06 dB

Peak SAR (extrapolated) = 15.623 mW/g

SAR(1 g) = 8.87 mW/g; SAR(10 g) = 4.76 mW/g

Maximum value of SAR (measured) = 10.9 mW/g

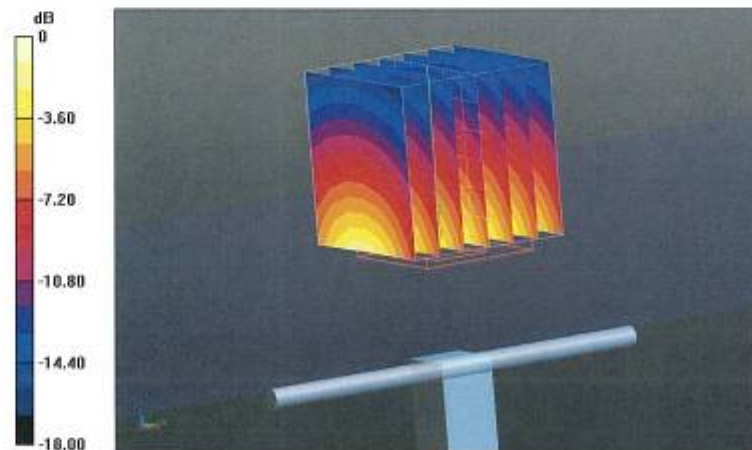

0 dB = 10.9 mW/g = 20.75 dB mW/g

Impedance Measurement Plot for Head TSL

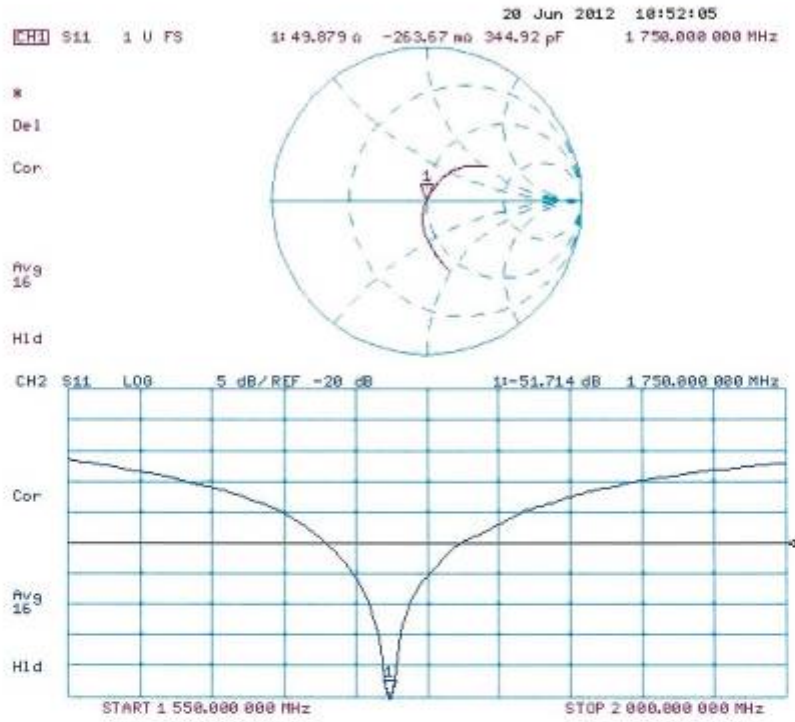

DASY5 Validation Report for Body TSL

Date: 20.06.2012

Test Laboratory: SPEAG, Zurich, Switzerland

DUT: Dipole 1750 MHz; Type: D1750V2; Serial: D1750V2 - SN: 1023

Communication System: CW; Frequency: 1750 MHz

Medium parameters used: $f = 1750$ MHz; $\sigma = 1.47$ mho/m; $\epsilon_r = 52.5$; $\rho = 1000$ kg/m³

Phantom section: Flat Section

Measurement Standard: DASY5 (IEEE/IEC/ANSI C63.19-2007)

DASY52 Configuration:

- Probe: ES3DV3 - SN3205; ConvF(4.85, 4.85, 4.85); Calibrated: 30.12.2011;
- Sensor-Surface: 3mm (Mechanical Surface Detection)
- Electronics: DAE4 Sn601; Calibrated: 04.07.2011
- Phantom: Flat Phantom 5.0 (back); Type: QD000P50AA; Serial: 1002
- DASY52 52.8.1(838); SEMCAD X 14.6.5(6469)

Dipole Calibration for Body Tissue/Pin=250 mW, d=10mm/Zoom Scan (7x7x7)/Cube 0:

Measurement grid: dx=5mm, dy=5mm, dz=5mm

Reference Value = 92.628 V/m; Power Drift = -0.01 dB

Peak SAR (extrapolated) = 15.781 mW/g

SAR(1 g) = 9.22 mW/g; SAR(10 g) = 4.97 mW/g

Maximum value of SAR (measured) = 11.6 mW/g

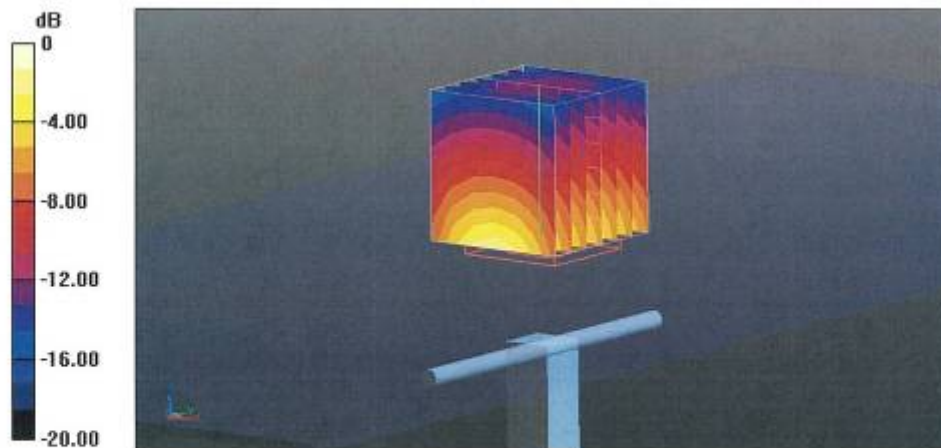

Impedance Measurement Plot for Body TSL

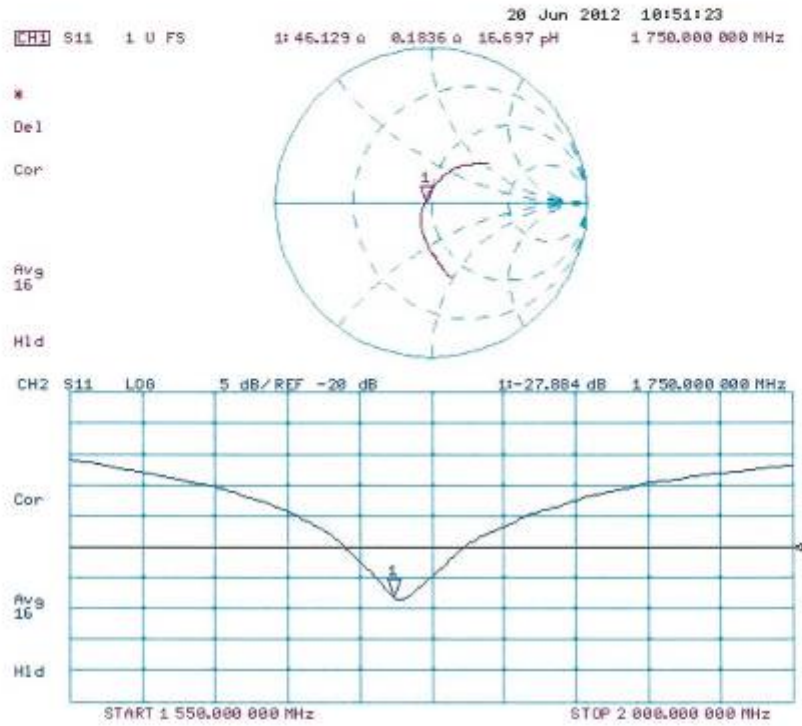

TA Technology (Shanghai) Co., Ltd. Test Report

Report No.: RXA1307-0093SAR01R3

Page 197 of 225

ANNEX G: D1900V2 Dipole Calibration Certificate

**Calibration Laboratory of
Schmid & Partner
Engineering AG**
Zeughausstrasse 43, 8004 Zurich, Switzerland



S Schweizerischer Kalibrierdienst
C Service suisse d'étalonnage
S Servizio svizzero di taratura
S Swiss Calibration Service

Accredited by the Swiss Accreditation Service (SAS)
The Swiss Accreditation Service is one of the signatories to the EA
Multilateral Agreement for the recognition of calibration certificates

Accreditation No.: **SCS 108**

Client **TA-Shanghai (Auden)**

Certificate No: **D1900V2-5d060_Aug11**

CALIBRATION CERTIFICATE																																															
Object	D1900V2 - SN: 5d060																																														
Calibration procedure(s)	QA CAL-05.v8 Calibration procedure for dipole validation kits above 700 MHz																																														
Calibration date:	August 31, 2011																																														
<p>This calibration certificate documents the traceability to national standards, which realize the physical units of measurements (SI). The measurements and the uncertainties with confidence probability are given on the following pages and are part of the certificate.</p> <p>All calibrations have been conducted in the closed laboratory facility: environment temperature (22 ± 3)°C and humidity < 70%.</p> <p>Calibration Equipment used (M&TE critical for calibration)</p> <table border="1" style="width: 100%; border-collapse: collapse;"> <thead> <tr> <th style="width: 30%;">Primary Standards</th> <th style="width: 15%;">ID #</th> <th style="width: 30%;">Cal Date (Certificate No.)</th> <th style="width: 25%;">Scheduled Calibration</th> </tr> </thead> <tbody> <tr> <td>Power meter EPM-442A</td> <td>GB37480704</td> <td>06-Oct-10 (No. 217-01266)</td> <td>Oct-11</td> </tr> <tr> <td>Power sensor HP 8481A</td> <td>US37292783</td> <td>06-Oct-10 (No. 217-01266)</td> <td>Oct-11</td> </tr> <tr> <td>Reference 20 dB Attenuator</td> <td>SN: S5086 (20b)</td> <td>29-Mar-11 (No. 217-01367)</td> <td>Apr-12</td> </tr> <tr> <td>Type-N mismatch combination</td> <td>SN: 5047.2 / 06327</td> <td>29-Mar-11 (No. 217-01371)</td> <td>Apr-12</td> </tr> <tr> <td>Reference Probe ES3DV3</td> <td>SN: 3205</td> <td>29-Apr-11 (No. ES3-3205_Apr11)</td> <td>Apr-12</td> </tr> <tr> <td>DAE4</td> <td>SN: 601</td> <td>04-Jul-11 (No. DAE4-601_Jul11)</td> <td>Jul-12</td> </tr> </tbody> </table> <table border="1" style="width: 100%; border-collapse: collapse;"> <thead> <tr> <th style="width: 30%;">Secondary Standards</th> <th style="width: 15%;">ID #</th> <th style="width: 30%;">Check Date (in house)</th> <th style="width: 25%;">Scheduled Check</th> </tr> </thead> <tbody> <tr> <td>Power sensor HP 8481A</td> <td>MY41092317</td> <td>18-Oct-02 (in house check Oct-09)</td> <td>In house check: Oct-11</td> </tr> <tr> <td>RF generator R&S SMT-06</td> <td>100005</td> <td>04-Aug-99 (in house check Oct-09)</td> <td>In house check: Oct-11</td> </tr> <tr> <td>Network Analyzer HP 8753E</td> <td>US37390585 S4206</td> <td>18-Oct-01 (in house check Oct-10)</td> <td>In house check: Oct-11</td> </tr> </tbody> </table>				Primary Standards	ID #	Cal Date (Certificate No.)	Scheduled Calibration	Power meter EPM-442A	GB37480704	06-Oct-10 (No. 217-01266)	Oct-11	Power sensor HP 8481A	US37292783	06-Oct-10 (No. 217-01266)	Oct-11	Reference 20 dB Attenuator	SN: S5086 (20b)	29-Mar-11 (No. 217-01367)	Apr-12	Type-N mismatch combination	SN: 5047.2 / 06327	29-Mar-11 (No. 217-01371)	Apr-12	Reference Probe ES3DV3	SN: 3205	29-Apr-11 (No. ES3-3205_Apr11)	Apr-12	DAE4	SN: 601	04-Jul-11 (No. DAE4-601_Jul11)	Jul-12	Secondary Standards	ID #	Check Date (in house)	Scheduled Check	Power sensor HP 8481A	MY41092317	18-Oct-02 (in house check Oct-09)	In house check: Oct-11	RF generator R&S SMT-06	100005	04-Aug-99 (in house check Oct-09)	In house check: Oct-11	Network Analyzer HP 8753E	US37390585 S4206	18-Oct-01 (in house check Oct-10)	In house check: Oct-11
Primary Standards	ID #	Cal Date (Certificate No.)	Scheduled Calibration																																												
Power meter EPM-442A	GB37480704	06-Oct-10 (No. 217-01266)	Oct-11																																												
Power sensor HP 8481A	US37292783	06-Oct-10 (No. 217-01266)	Oct-11																																												
Reference 20 dB Attenuator	SN: S5086 (20b)	29-Mar-11 (No. 217-01367)	Apr-12																																												
Type-N mismatch combination	SN: 5047.2 / 06327	29-Mar-11 (No. 217-01371)	Apr-12																																												
Reference Probe ES3DV3	SN: 3205	29-Apr-11 (No. ES3-3205_Apr11)	Apr-12																																												
DAE4	SN: 601	04-Jul-11 (No. DAE4-601_Jul11)	Jul-12																																												
Secondary Standards	ID #	Check Date (in house)	Scheduled Check																																												
Power sensor HP 8481A	MY41092317	18-Oct-02 (in house check Oct-09)	In house check: Oct-11																																												
RF generator R&S SMT-06	100005	04-Aug-99 (in house check Oct-09)	In house check: Oct-11																																												
Network Analyzer HP 8753E	US37390585 S4206	18-Oct-01 (in house check Oct-10)	In house check: Oct-11																																												
Calibrated by:	Name Dimce Iliev	Function Laboratory Technician	Signature 																																												
Approved by:	Name Katja Pokovic	Technical Manager																																													
			Issued: August 31, 2011																																												
This calibration certificate shall not be reproduced except in full without written approval of the laboratory.																																															

TA Technology (Shanghai) Co., Ltd.

Test Report

Report No.: RXA1307-0093SAR01R3

Page 198 of 225

**Calibration Laboratory of
Schmid & Partner
Engineering AG**
Zeughausstrasse 43, 8004 Zurich, Switzerland



S Schweizerischer Kalibrierdienst
S Service suisse d'étalonnage
C Servizio svizzero di taratura
S Swiss Calibration Service

Accredited by the Swiss Accreditation Service (SAS)

The Swiss Accreditation Service is one of the signatories to the EA
Multilateral Agreement for the recognition of calibration certificates

Accreditation No.: **SCS 108**

Glossary:

TSL	tissue simulating liquid
ConvF	sensitivity in TSL / NORM x,y,z
N/A	not applicable or not measured

Calibration is Performed According to the Following Standards:

- IEEE Std 1528-2003, "IEEE Recommended Practice for Determining the Peak Spatial-Averaged Specific Absorption Rate (SAR) in the Human Head from Wireless Communications Devices: Measurement Techniques", December 2003
- IEC 62209-1, "Procedure to measure the Specific Absorption Rate (SAR) for hand-held devices used in close proximity to the ear (frequency range of 300 MHz to 3 GHz)", February 2005
- Federal Communications Commission Office of Engineering & Technology (FCC OET), "Evaluating Compliance with FCC Guidelines for Human Exposure to Radiofrequency Electromagnetic Fields; Additional Information for Evaluating Compliance of Mobile and Portable Devices with FCC Limits for Human Exposure to Radiofrequency Emissions", Supplement C (Edition 01-01) to Bulletin 65

Additional Documentation:

- DASY4/5 System Handbook

Methods Applied and Interpretation of Parameters:

- Measurement Conditions:** Further details are available from the Validation Report at the end of the certificate. All figures stated in the certificate are valid at the frequency indicated.
- Antenna Parameters with TSL:** The dipole is mounted with the spacer to position its feed point exactly below the center marking of the flat phantom section, with the arms oriented parallel to the body axis.
- Feed Point Impedance and Return Loss:** These parameters are measured with the dipole positioned under the liquid filled phantom. The impedance stated is transformed from the measurement at the SMA connector to the feed point. The Return Loss ensures low reflected power. No uncertainty required.
- Electrical Delay:** One-way delay between the SMA connector and the antenna feed point. No uncertainty required.
- SAR measured:** SAR measured at the stated antenna input power.
- SAR normalized:** SAR as measured, normalized to an input power of 1 W at the antenna connector.
- SAR for nominal TSL parameters:** The measured TSL parameters are used to calculate the nominal SAR result.

TA Technology (Shanghai) Co., Ltd.

Test Report

Measurement Conditions

DASY system configuration, as far as not given on page 1.

DASY Version	DASY5	V52.6.2
Extrapolation	Advanced Extrapolation	
Phantom	Modular Flat Phantom	
Distance Dipole Center - TSL	10 mm	with Spacer
Zoom Scan Resolution	dx, dy, dz = 5 mm	
Frequency	1900 MHz \pm 1 MHz	

Head TSL parameters

The following parameters and calculations were applied.

	Temperature	Permittivity	Conductivity
Nominal Head TSL parameters	22.0 °C	40.0	1.40 mho/m
Measured Head TSL parameters	(22.0 \pm 0.2) °C	39.5 \pm 6 %	1.42 mho/m \pm 6 %
Head TSL temperature change during test	< 0.5 °C	----	----

SAR result with Head TSL

SAR averaged over 1 cm ³ (1 g) of Head TSL	Condition	
SAR measured	250 mW input power	10.2 mW / g
SAR for nominal Head TSL parameters	normalized to 1W	40.3 mW / g \pm 17.0 % (k=2)

SAR averaged over 10 cm ³ (10 g) of Head TSL	condition	
SAR measured	250 mW input power	5.30 mW / g
SAR for nominal Head TSL parameters	normalized to 1W	21.1 mW / g \pm 16.5 % (k=2)

Body TSL parameters

The following parameters and calculations were applied.

	Temperature	Permittivity	Conductivity
Nominal Body TSL parameters	22.0 °C	53.3	1.52 mho/m
Measured Body TSL parameters	(22.0 \pm 0.2) °C	53.9 \pm 6 %	1.57 mho/m \pm 6 %
Body TSL temperature change during test	< 0.5 °C	----	----

SAR result with Body TSL

SAR averaged over 1 cm ³ (1 g) of Body TSL	Condition	
SAR measured	250 mW input power	10.6 mW / g
SAR for nominal Body TSL parameters	normalized to 1W	41.7 mW / g \pm 17.0 % (k=2)

SAR averaged over 10 cm ³ (10 g) of Body TSL	condition	
SAR measured	250 mW input power	5.55 mW / g
SAR for nominal Body TSL parameters	normalized to 1W	22.0 mW / g \pm 16.5 % (k=2)

TA Technology (Shanghai) Co., Ltd.

Test Report

Appendix

Antenna Parameters with Head TSL

Impedance, transformed to feed point	52.6 Ω + 7.5 j Ω
Return Loss	- 22.3 dB

Antenna Parameters with Body TSL

Impedance, transformed to feed point	47.3 Ω + 7.9 j Ω
Return Loss	- 21.3 dB

General Antenna Parameters and Design

Electrical Delay (one direction)	1.194 ns
----------------------------------	----------

After long term use with 100W radiated power, only a slight warming of the dipole near the feedpoint can be measured.

The dipole is made of standard semirigid coaxial cable. The center conductor of the feeding line is directly connected to the second arm of the dipole. The antenna is therefore short-circuited for DC-signals.

No excessive force must be applied to the dipole arms, because they might bend or the soldered connections near the feedpoint may be damaged.

Additional EUT Data

Manufactured by	SPEAG
Manufactured on	December 10, 2004

DASY5 Validation Report for Head TSL

Date: 30.08.2011

Test Laboratory: SPEAG, Zurich, Switzerland

DUT: Dipole 1900 MHz; Type: D1900V2; Serial: D1900V2 - SN: 5d060

Communication System: CW; Frequency: 1900 MHz

Medium parameters used: $f = 1900$ MHz; $\sigma = 1.42$ mho/m; $\epsilon_r = 39.5$; $\rho = 1000$ kg/m³

Phantom section: Flat Section

Measurement Standard: DASY5 (IEEE/IEC/ANSI C63.19-2007)

DASY52 Configuration:

- Probe: ES3DV3 - SN3205; ConvF(5.01, 5.01, 5.01); Calibrated: 29.04.2011
- Sensor-Surface: 3mm (Mechanical Surface Detection)
- Electronics: DAE4 Sn601; Calibrated: 04.07.2011
- Phantom: Flat Phantom 5.0 (front); Type: QD000P50AA; Serial: 1001
- DASY52 52.6.2(482); SEMCAD X 14.4.5(3634)

Dipole Calibration for Head Tissue/Pin=250 mW, d=10mm/Zoom Scan (7x7x7)/Cube 0:

Measurement grid: dx=5mm, dy=5mm, dz=5mm

Reference Value = 97.636 V/m; Power Drift = 0.07 dB

Peak SAR (extrapolated) = 18.535 W/kg

SAR(1 g) = 10.2 mW/g; SAR(10 g) = 5.3 mW/g

Maximum value of SAR (measured) = 12.600 mW/g

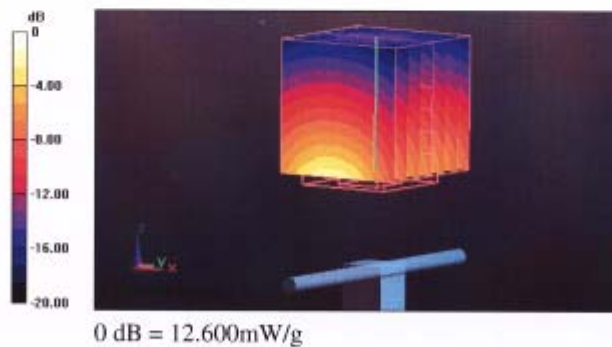

Impedance Measurement Plot for Head TSL

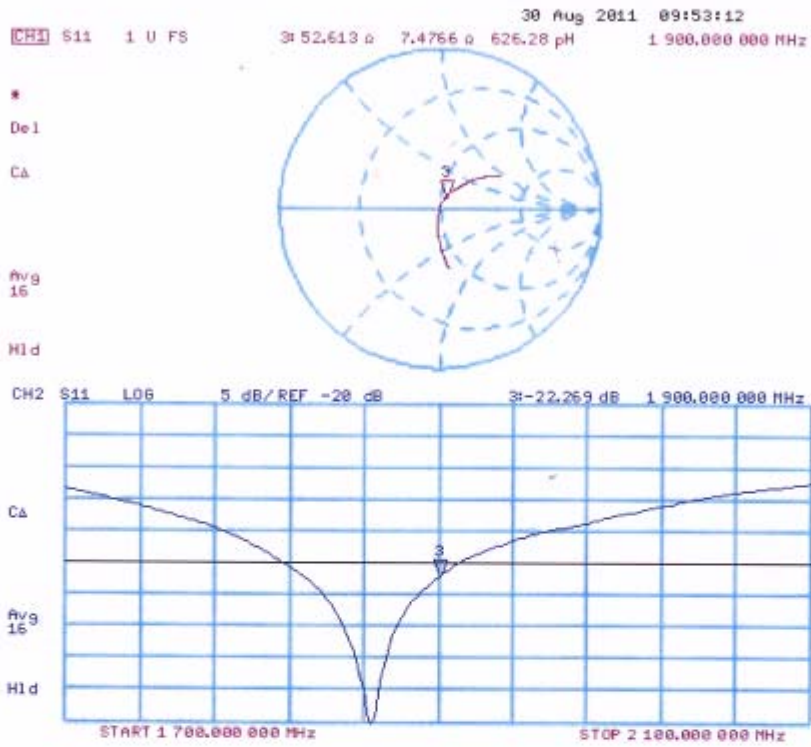

DASY5 Validation Report for Body TSL

Date: 31.08.2011

Test Laboratory: SPEAG, Zurich, Switzerland

DUT: Dipole 1900 MHz; Type: D1900V2; Serial: D1900V2 - SN: 5d060

Communication System: CW; Frequency: 1900 MHz

Medium parameters used: $f = 1900$ MHz; $\sigma = 1.57$ mho/m; $\epsilon_r = 53.9$; $\rho = 1000$ kg/m³

Phantom section: Flat Section

Measurement Standard: DASY5 (IEEE/IEC/ANSI C63.19-2007)

DASY52 Configuration:

- Probe: ES3DV3 - SN3205; ConvF(4.62, 4.62, 4.62); Calibrated: 29.04.2011
- Sensor-Surface: 3mm (Mechanical Surface Detection)
- Electronics: DAE4 Sn601; Calibrated: 04.07.2011
- Phantom: Flat Phantom 5.0 (back); Type: QD000P50AA; Serial: 1002
- DASY52 52.6.2(482); SEMCAD X 14.4.5(3634)

Dipole Calibration for Body Tissue/Pin=250 mW, d=10mm/Zoom Scan (7x7x7)/Cube 0:

Measurement grid: dx=5mm, dy=5mm, dz=5mm

Reference Value = 96.435 V/m; Power Drift = -0.0099 dB

Peak SAR (extrapolated) = 18.663 W/kg

SAR(1 g) = 10.6 mW/g; SAR(10 g) = 5.55 mW/g

Maximum value of SAR (measured) = 13.397 mW/g

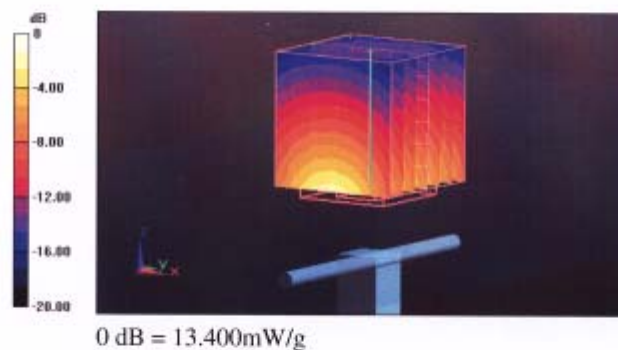

TA Technology (Shanghai) Co., Ltd. Test Report

Report No.: RXA1307-0093SAR01R3

Page 204 of 225

Impedance Measurement Plot for Body TSL

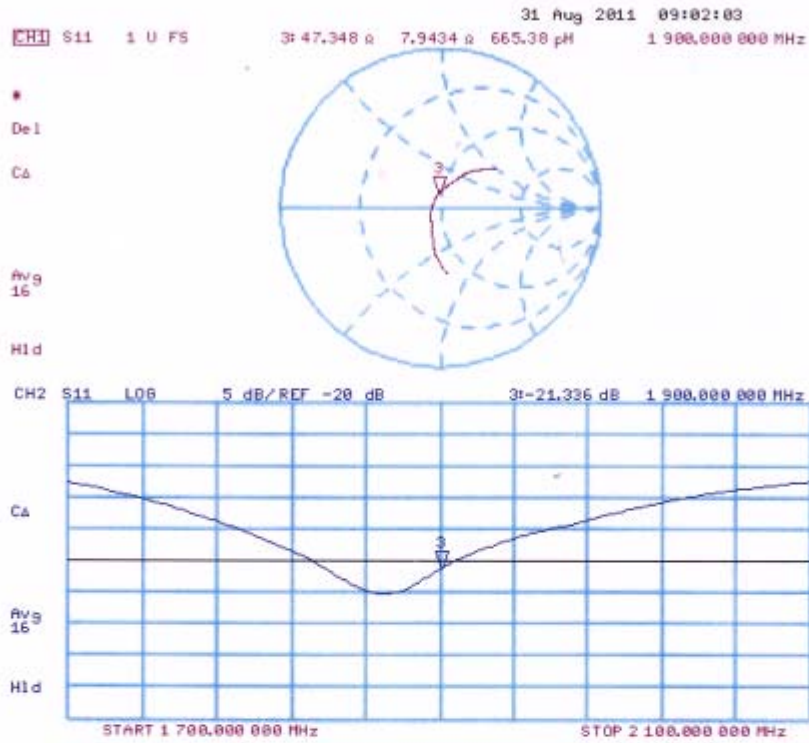

TA Technology (Shanghai) Co., Ltd. Test Report

Report No.: RXA1307-0093SAR01R3

Page 205 of 225

ANNEX H: D2450V2 Dipole Calibration Certificate

**Calibration Laboratory of
Schmid & Partner
Engineering AG**
Zeughausstrasse 43, 8004 Zurich, Switzerland



S Schweizerischer Kalibrierdienst
C Service suisse d'étalonnage
S Servizio svizzero di taratura
S Swiss Calibration Service

Accredited by the Swiss Accreditation Service (SAS)
The Swiss Accreditation Service is one of the signatories to the EA
Multilateral Agreement for the recognition of calibration certificates

Accreditation No.: **SCS 108**

Client **TA-Shanghai (Auden)**

Certificate No: **D2450V2-786_Aug11**

CALIBRATION CERTIFICATE

Object: **D2450V2 - SN: 786**

Calibration procedure(s): **QA CAL-05.v8
Calibration procedure for dipole validation kits above 700 MHz**

Calibration date: **August 29, 2011**

This calibration certificate documents the traceability to national standards, which realize the physical units of measurements (SI).
The measurements and the uncertainties with confidence probability are given on the following pages and are part of the certificate.

All calibrations have been conducted in the closed laboratory facility: environment temperature (22 ± 3)°C and humidity < 70%.

Calibration Equipment used (M&TE critical for calibration)

Primary Standards	ID #	Cal Date (Certificate No.)	Scheduled Calibration
Power meter EPM-442A	GB37480704	06-Oct-10 (No. 217-01266)	Oct-11
Power sensor HP 8481A	US37292783	06-Oct-10 (No. 217-01266)	Oct-11
Reference 20 dB Attenuator	SN: S5086 (20b)	29-Mar-11 (No. 217-01367)	Apr-12
Type-N mismatch combination	SN: 5047.2 / 06327	29-Mar-11 (No. 217-01371)	Apr-12
Reference Probe ES3DV3	SN: 3205	29-Apr-11 (No. ES3-3205_Apr11)	Apr-12
DAE4	SN: 601	04-Jul-11 (No. DAE4-601_Jul11)	Jul-12
Secondary Standards	ID #	Check Date (in house)	Scheduled Check
Power sensor HP 8481A	MY41092317	18-Oct-02 (in house check Oct-09)	In house check: Oct-11
RF generator R&S SMT-06	100005	04-Aug-99 (in house check Oct-09)	In house check: Oct-11
Network Analyzer HP 8753E	US37390585 S4206	18-Oct-01 (in house check Oct-10)	In house check: Oct-11

	Name	Function	Signature
Calibrated by:	Dimce Iliev	Laboratory Technician	
Approved by:	Katja Pokovic	Technical Manager	

Issued: August 29, 2011

This calibration certificate shall not be reproduced except in full without written approval of the laboratory.

TA Technology (Shanghai) Co., Ltd.

Test Report

Report No.: RXA1307-0093SAR01R3

Page 206 of 225

**Calibration Laboratory of
Schmid & Partner
Engineering AG**
Zeughausstrasse 43, 8004 Zurich, Switzerland



S Schweizerischer Kalibrierdienst
C Service suisse d'étalonnage
S Servizio svizzero di taratura
S Swiss Calibration Service

Accredited by the Swiss Accreditation Service (SAS)

The Swiss Accreditation Service is one of the signatories to the EA
Multilateral Agreement for the recognition of calibration certificates

Accreditation No.: **SCS 108**

Glossary:

TSL	tissue simulating liquid
ConvF	sensitivity in TSL / NORM x,y,z
N/A	not applicable or not measured

Calibration is Performed According to the Following Standards:

- IEEE Std 1528-2003, "IEEE Recommended Practice for Determining the Peak Spatial-Averaged Specific Absorption Rate (SAR) in the Human Head from Wireless Communications Devices: Measurement Techniques", December 2003
- IEC 62209-1, "Procedure to measure the Specific Absorption Rate (SAR) for hand-held devices used in close proximity to the ear (frequency range of 300 MHz to 3 GHz)", February 2005
- Federal Communications Commission Office of Engineering & Technology (FCC OET), "Evaluating Compliance with FCC Guidelines for Human Exposure to Radiofrequency Electromagnetic Fields; Additional Information for Evaluating Compliance of Mobile and Portable Devices with FCC Limits for Human Exposure to Radiofrequency Emissions", Supplement C (Edition 01-01) to Bulletin 65

Additional Documentation:

- DASY4/5 System Handbook

Methods Applied and Interpretation of Parameters:

- Measurement Conditions:** Further details are available from the Validation Report at the end of the certificate. All figures stated in the certificate are valid at the frequency indicated.
- Antenna Parameters with TSL:** The dipole is mounted with the spacer to position its feed point exactly below the center marking of the flat phantom section, with the arms oriented parallel to the body axis.
- Feed Point Impedance and Return Loss:** These parameters are measured with the dipole positioned under the liquid filled phantom. The impedance stated is transformed from the measurement at the SMA connector to the feed point. The Return Loss ensures low reflected power. No uncertainty required.
- Electrical Delay:** One-way delay between the SMA connector and the antenna feed point. No uncertainty required.
- SAR measured:** SAR measured at the stated antenna input power.
- SAR normalized:** SAR as measured, normalized to an input power of 1 W at the antenna connector.
- SAR for nominal TSL parameters:** The measured TSL parameters are used to calculate the nominal SAR result.

TA Technology (Shanghai) Co., Ltd.

Test Report

Measurement Conditions

DASY system configuration, as far as not given on page 1.

DASY Version	DASY5	V52.6.2
Extrapolation	Advanced Extrapolation	
Phantom	Modular Flat Phantom	
Distance Dipole Center - TSL	10 mm	with Spacer
Zoom Scan Resolution	dx, dy, dz = 5 mm	
Frequency	2450 MHz ± 1 MHz	

Head TSL parameters

The following parameters and calculations were applied.

	Temperature	Permittivity	Conductivity
Nominal Head TSL parameters	22.0 °C	39.2	1.80 mho/m
Measured Head TSL parameters	(22.0 ± 0.2) °C	38.4 ± 6 %	1.85 mho/m ± 6 %
Head TSL temperature change during test	< 0.5 °C	----	----

SAR result with Head TSL

SAR averaged over 1 cm ³ (1 g) of Head TSL	Condition	
SAR measured	250 mW input power	13.7 mW / g
SAR for nominal Head TSL parameters	normalized to 1W	53.8 mW / g ± 17.0 % (k=2)

SAR averaged over 10 cm ³ (10 g) of Head TSL	condition	
SAR measured	250 mW input power	6.41 mW / g
SAR for nominal Head TSL parameters	normalized to 1W	25.4 mW / g ± 16.5 % (k=2)

Body TSL parameters

The following parameters and calculations were applied.

	Temperature	Permittivity	Conductivity
Nominal Body TSL parameters	22.0 °C	52.7	1.95 mho/m
Measured Body TSL parameters	(22.0 ± 0.2) °C	51.8 ± 6 %	2.02 mho/m ± 6 %
Body TSL temperature change during test	< 0.5 °C	----	----

SAR result with Body TSL

SAR averaged over 1 cm ³ (1 g) of Body TSL	Condition	
SAR measured	250 mW input power	13.2 mW / g
SAR for nominal Body TSL parameters	normalized to 1W	51.7 mW / g ± 17.0 % (k=2)

SAR averaged over 10 cm ³ (10 g) of Body TSL	condition	
SAR measured	250 mW input power	6.10 mW / g
SAR for nominal Body TSL parameters	normalized to 1W	24.2 mW / g ± 16.5 % (k=2)

TA Technology (Shanghai) Co., Ltd.

Test Report

Appendix

Antenna Parameters with Head TSL

Impedance, transformed to feed point	55.0 Ω + 2.4 $j\Omega$
Return Loss	- 25.5 dB

Antenna Parameters with Body TSL

Impedance, transformed to feed point	50.4 Ω + 3.5 $j\Omega$
Return Loss	- 29.0 dB

General Antenna Parameters and Design

Electrical Delay (one direction)	1.154 ns
----------------------------------	----------

After long term use with 100W radiated power, only a slight warming of the dipole near the feedpoint can be measured.

The dipole is made of standard semirigid coaxial cable. The center conductor of the feeding line is directly connected to the second arm of the dipole. The antenna is therefore short-circuited for DC-signals.

No excessive force must be applied to the dipole arms, because they might bend or the soldered connections near the feedpoint may be damaged.

Additional EUT Data

Manufactured by	SPEAG
Manufactured on	May 06, 2005

DASY5 Validation Report for Head TSL

Date: 29.08.2011

Test Laboratory: SPEAG, Zurich, Switzerland

DUT: Dipole 2450 MHz; Type: D2450V2; Serial: D2450V2 - SN: 786

Communication System: CW; Frequency: 2450 MHz

Medium parameters used: $f = 2450$ MHz; $\sigma = 1.85$ mho/m; $\epsilon_r = 38.4$; $\rho = 1000$ kg/m³

Phantom section: Flat Section

Measurement Standard: DASY5 (IEEE/IEC/ANSI C63.19-2007)

DASY52 Configuration:

- Probe: ES3DV3 - SN3205; ConvF(4.45, 4.45, 4.45); Calibrated: 29.04.2011
- Sensor-Surface: 3mm (Mechanical Surface Detection)
- Electronics: DAE4 Sn601; Calibrated: 04.07.2011
- Phantom: Flat Phantom 5.0 (front); Type: QD000P50AA; Serial: 1001
- DASY52 52.6.2(482); SEMCAD X 14.4.5(3634)

Dipole Calibration for Head Tissue/Pin=250 mW, d=10mm/Zoom Scan (7x7x7)/Cube 0:

Measurement grid: dx=5mm, dy=5mm, dz=5mm

Reference Value = 101.5 V/m; Power Drift = 0.06 dB

Peak SAR (extrapolated) = 28.303 W/kg

SAR(1 g) = 13.7 mW/g; SAR(10 g) = 6.41 mW/g

Maximum value of SAR (measured) = 17.561 mW/g

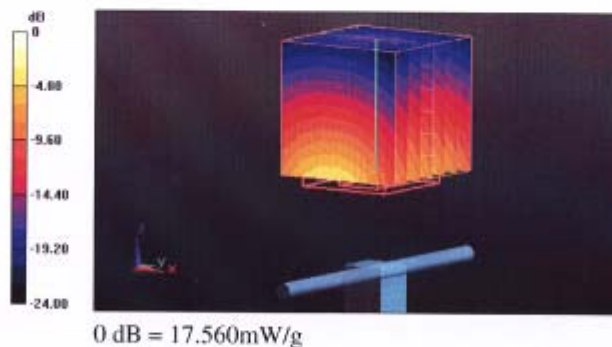

TA Technology (Shanghai) Co., Ltd. Test Report

Report No.: RXA1307-0093SAR01R3

Page 210 of 225

Impedance Measurement Plot for Head TSL

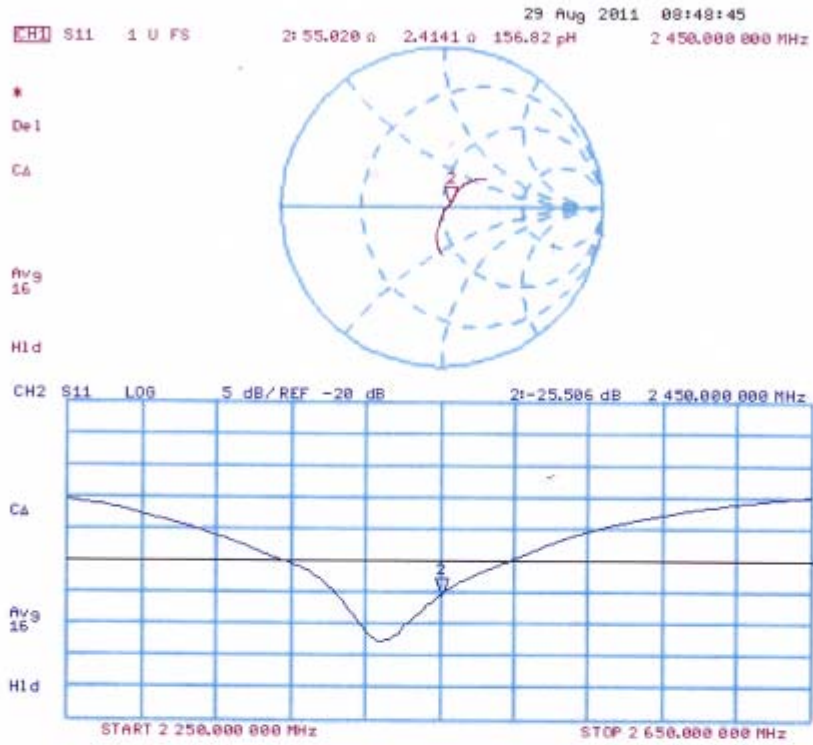

DASY5 Validation Report for Body TSL

Date: 29.08.2011

Test Laboratory: SPEAG, Zurich, Switzerland

DUT: Dipole 2450 MHz; Type: D2450V2; Serial: D2450V2 - SN: 786

Communication System: CW; Frequency: 2450 MHz

Medium parameters used: $f = 2450$ MHz; $\sigma = 2.02$ mho/m; $\epsilon_r = 51.8$; $\rho = 1000$ kg/m³

Phantom section: Flat Section

Measurement Standard: DASY5 (IEEE/IEC/ANSI C63.19-2007)

DASY52 Configuration:

- Probe: ES3DV3 - SN3205; ConvF(4.26, 4.26, 4.26); Calibrated: 29.04.2011
- Sensor-Surface: 3mm (Mechanical Surface Detection)
- Electronics: DAE4 Sn601; Calibrated: 04.07.2011
- Phantom: Flat Phantom 5.0 (back); Type: QD000P50AA; Serial: 1002
- DASY52 52.6.2(482); SEMCAD X 14.4.5(3634)

Dipole Calibration for Body Tissue/Pin=250 mW, d=10mm/Zoom Scan (7x7x7)/Cube 0:

Measurement grid: dx=5mm, dy=5mm, dz=5mm

Reference Value = 96.118 V/m; Power Drift = 0.0072 dB

Peak SAR (extrapolated) = 27.129 W/kg

SAR(1 g) = 13.2 mW/g; SAR(10 g) = 6.1 mW/g

Maximum value of SAR (measured) = 17.387 mW/g

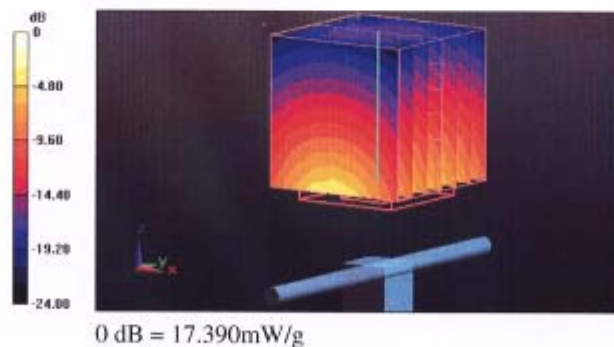

TA Technology (Shanghai) Co., Ltd.
Test Report

Report No.: RXA1307-0093SAR01R3

Page 212 of 225

Impedance Measurement Plot for Body TSL

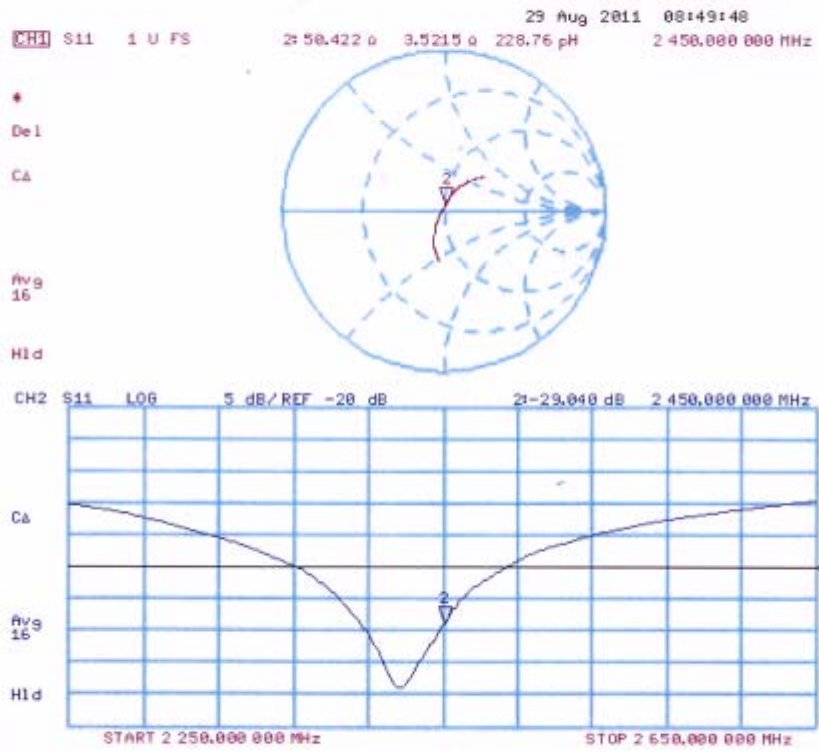

TA Technology (Shanghai) Co., Ltd. Test Report

Report No.: RXA1307-0093SAR01R3

Page 213 of 225

ANNEX I: DAE4 Calibration Certificate

**Calibration Laboratory of
Schmid & Partner
Engineering AG**
Zeughausstrasse 43, 8004 Zurich, Switzerland



S Schweizerischer Kalibrierdienst
S Service suisse d'étalonnage
C Servizio svizzero di taratura
S Swiss Calibration Service

Accredited by the Swiss Accreditation Service (SAS)
The Swiss Accreditation Service is one of the signatories to the EA
Multilateral Agreement for the recognition of calibration certificates

Accreditation No.: **SCS 108**

Client **TA Shanghai (Auden)**

Certificate No: **DAE4-1317_Jan13**

CALIBRATION CERTIFICATE

Object **DAE4 - SD 000 D04 BJ - SN: 1317**

Calibration procedure(s) **QA CAL-06.v25
Calibration procedure for the data acquisition electronics (DAE)**

Calibration date: **January 25, 2013**

This calibration certificate documents the traceability to national standards, which realize the physical units of measurements (SI).
The measurements and the uncertainties with confidence probability are given on the following pages and are part of the certificate.

All calibrations have been conducted in the closed laboratory facility: environment temperature (22 ± 3)°C and humidity < 70%.

Calibration Equipment used (M&TE critical for calibration)

Primary Standards	ID #	Cal Date (Certificate No.)	Scheduled Calibration
Keithley Multimeter Type 2001	SN: 0810278	02-Oct-12 (No:12728)	Oct-13
Secondary Standards	ID #	Check Date (in house)	Scheduled Check
Auto DAE Calibration Unit	SE UWS 053 AA 1001	07-Jan-13 (in house check)	In house check: Jan-14
Calibrator Box V2.1	SE UMS 006 AA 1002	07-Jan-13 (in house check)	In house check: Jan-14

	Name	Function	Signature
Calibrated by:	R. Mayoraz	Technician	<i>R. Mayoraz</i>
Approved by:	Fin Bomholt	Deputy Technical Manager	<i>Fin Bomholt</i>

Issued: January 25, 2013

This calibration certificate shall not be reproduced except in full without written approval of the laboratory.

TA Technology (Shanghai) Co., Ltd.

Test Report

Report No.: RXA1307-0093SAR01R3

Page 214 of 225

**Calibration Laboratory of
Schmid & Partner
Engineering AG**
Zeughausstrasse 43, 8004 Zurich, Switzerland



S Schweizerischer Kalibrierdienst
C Service suisse d'étalonnage
S Servizio svizzero di taratura
S Swiss Calibration Service

Accredited by the Swiss Accreditation Service (SAS)
The Swiss Accreditation Service is one of the signatories to the EA
Multilateral Agreement for the recognition of calibration certificates

Accreditation No.: **SCS 108**

Glossary

DAE data acquisition electronics
Connector angle information used in DASY system to align probe sensor X to the robot coordinate system.

Methods Applied and Interpretation of Parameters

- **DC Voltage Measurement:** Calibration Factor assessed for use in DASY system by comparison with a calibrated instrument traceable to national standards. The figure given corresponds to the full scale range of the voltmeter in the respective range.
- **Connector angle:** The angle of the connector is assessed measuring the angle mechanically by a tool inserted. Uncertainty is not required.
- The following parameters as documented in the Appendix contain technical information as a result from the performance test and require no uncertainty.
 - **DC Voltage Measurement Linearity:** Verification of the Linearity at +10% and -10% of the nominal calibration voltage. Influence of offset voltage is included in this measurement.
 - **Common mode sensitivity:** Influence of a positive or negative common mode voltage on the differential measurement.
 - **Channel separation:** Influence of a voltage on the neighbor channels not subject to an input voltage.
 - **AD Converter Values with inputs shorted:** Values on the internal AD converter corresponding to zero input voltage
 - **Input Offset Measurement:** Output voltage and statistical results over a large number of zero voltage measurements.
 - **Input Offset Current:** Typical value for information; Maximum channel input offset current, not considering the input resistance.
 - **Input resistance:** Typical value for information: DAE input resistance at the connector, during internal auto-zeroing and during measurement.
 - **Low Battery Alarm Voltage:** Typical value for information. Below this voltage, a battery alarm signal is generated.
 - **Power consumption:** Typical value for information. Supply currents in various operating modes.

TA Technology (Shanghai) Co., Ltd.
Test Report

DC Voltage Measurement

A/D - Converter Resolution nominal

High Range: 1LSB = 6.1 μ V, full range = -100...+300 mV

Low Range: 1LSB = 61nV, full range = -1.....+3mV

DASY measurement parameters: Auto Zero Time: 3 sec; Measuring time: 3 sec

Calibration Factors	X	Y	Z
High Range	404.011 \pm 0.02% (k=2)	404.006 \pm 0.02% (k=2)	403.901 \pm 0.02% (k=2)
Low Range	3.98819 \pm 1.55% (k=2)	3.99805 \pm 1.55% (k=2)	3.98192 \pm 1.55% (k=2)

Connector Angle

Connector Angle to be used in DASY system	117 $^{\circ}$ \pm 1 $^{\circ}$
---	-----------------------------------

TA Technology (Shanghai) Co., Ltd.

Test Report

Appendix

1. DC Voltage Linearity

High Range		Reading (μV)	Difference (μV)	Error (%)
Channel X	+ Input	199994.16	-0.78	-0.00
Channel X	+ Input	20000.75	0.37	0.00
Channel X	- Input	-19997.98	2.89	-0.01
Channel Y	+ Input	199995.20	0.02	0.00
Channel Y	+ Input	19999.08	-1.15	-0.01
Channel Y	- Input	-20002.66	-1.68	0.01
Channel Z	+ Input	199994.67	-0.43	-0.00
Channel Z	+ Input	19997.92	-2.31	-0.01
Channel Z	- Input	-20000.66	0.26	-0.00

Low Range		Reading (μV)	Difference (μV)	Error (%)
Channel X	+ Input	2001.23	0.59	0.03
Channel X	+ Input	201.53	0.55	0.28
Channel X	- Input	-198.20	0.62	-0.31
Channel Y	+ Input	2000.33	-0.29	-0.01
Channel Y	+ Input	200.43	-0.68	-0.34
Channel Y	- Input	-199.64	-0.69	0.35
Channel Z	+ Input	2000.78	0.22	0.01
Channel Z	+ Input	200.32	-0.69	-0.34
Channel Z	- Input	-199.27	-0.35	0.18

2. Common mode sensitivity

DASY measurement parameters: Auto Zero Time: 3 sec; Measuring time: 3 sec

	Common mode Input Voltage (mV)	High Range Average Reading (μV)	Low Range Average Reading (μV)
Channel X	200	-23.69	-25.75
	- 200	28.59	26.45
Channel Y	200	-1.44	-1.70
	- 200	-0.06	-0.16
Channel Z	200	-10.76	-11.18
	- 200	9.82	9.91

3. Channel separation

DASY measurement parameters: Auto Zero Time: 3 sec; Measuring time: 3 sec

	Input Voltage (mV)	Channel X (μV)	Channel Y (μV)	Channel Z (μV)
Channel X	200	-	1.52	-4.72
Channel Y	200	8.54	-	4.31
Channel Z	200	10.79	5.34	-

TA Technology (Shanghai) Co., Ltd.

Test Report

Report No.: RXA1307-0093SAR01R3

Page 217 of 225

4. AD-Converter Values with inputs shorted

DASY measurement parameters: Auto Zero Time: 3 sec; Measuring time: 3 sec

	High Range (LSB)	Low Range (LSB)
Channel X	16104	15986
Channel Y	16111	15993
Channel Z	16217	16069

5. Input Offset Measurement

DASY measurement parameters: Auto Zero Time: 3 sec; Measuring time: 3 sec

Input 10M Ω

	Average (μ V)	min. Offset (μ V)	max. Offset (μ V)	Std. Deviation (μ V)
Channel X	1.28	0.53	2.45	0.33
Channel Y	-1.29	-2.89	0.51	0.58
Channel Z	-0.39	-1.47	1.06	0.37

6. Input Offset Current

Nominal Input circuitry offset current on all channels: <25fA

7. Input Resistance (Typical values for information)

	Zeroing (kOhm)	Measuring (MOhm)
Channel X	200	200
Channel Y	200	200
Channel Z	200	200

8. Low Battery Alarm Voltage (Typical values for information)

Typical values	Alarm Level (VDC)
Supply (+ Vcc)	+7.9
Supply (- Vcc)	-7.6

9. Power Consumption (Typical values for information)

Typical values	Switched off (mA)	Stand by (mA)	Transmitting (mA)
Supply (+ Vcc)	+0.01	+6	+14
Supply (- Vcc)	-0.01	-8	-9

ANNEX J: The EUT Appearances and Test Configuration

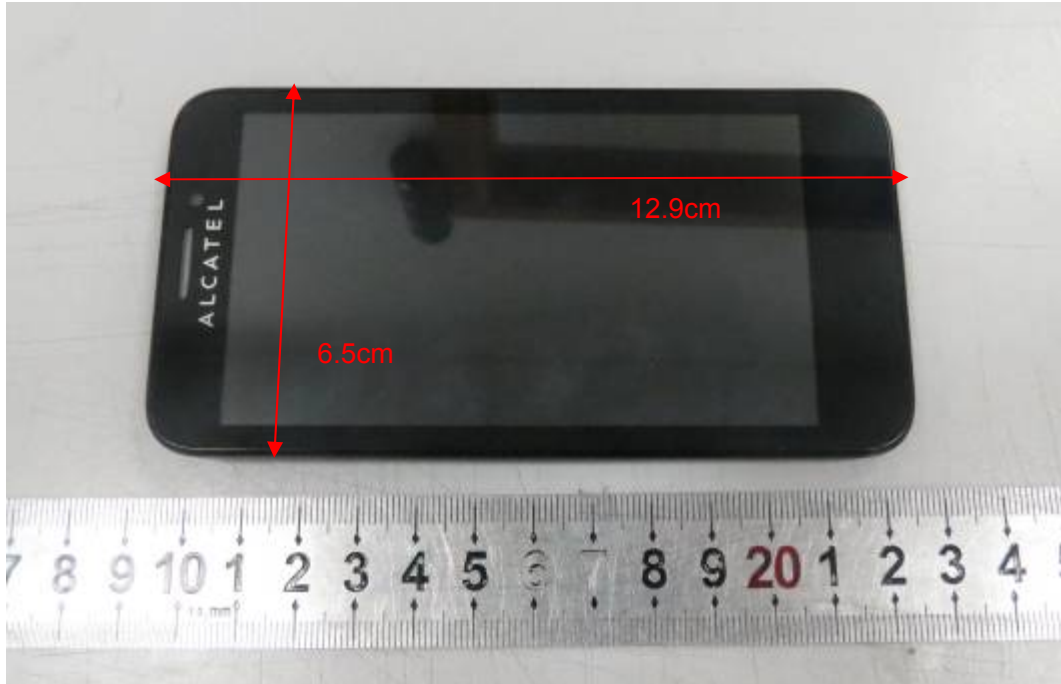

a: EUT

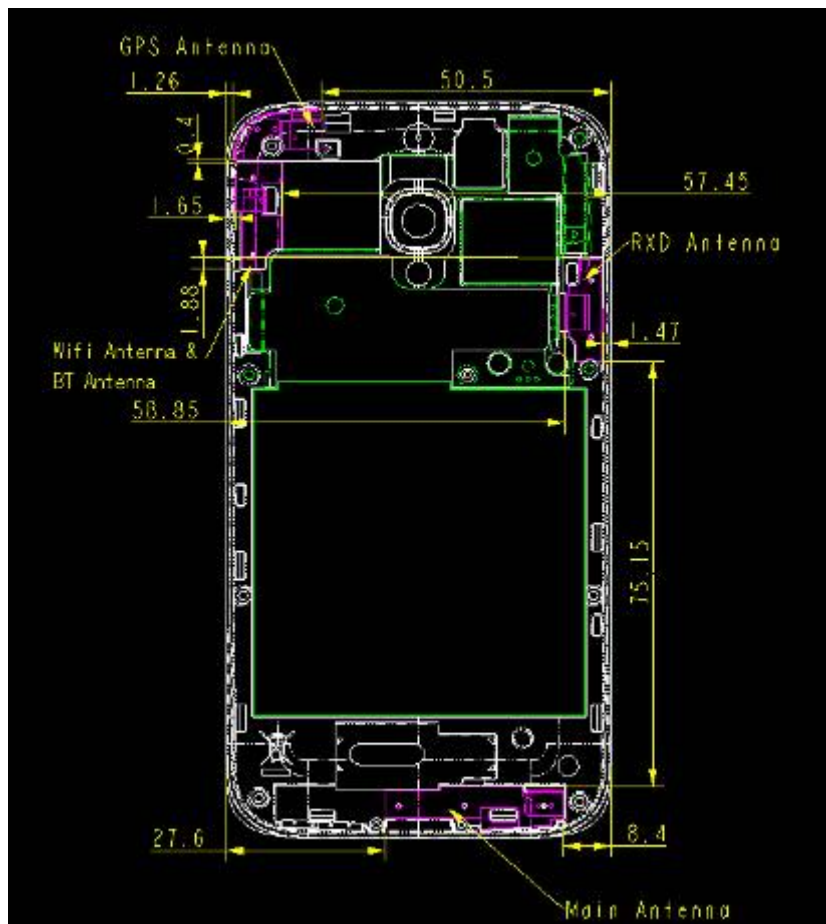

TA Technology (Shanghai) Co., Ltd.
Test Report



GPS Antenna inside housing

b: Back View

Picture 10: Constituents of EUT



Picture 11: Left Hand Touch Cheek Position



Picture 12: Left Hand Tilt 15 Degree Position



Picture 13: Right Hand Touch Cheek Position



Picture 14: Right Hand Tilt 15 Degree Position

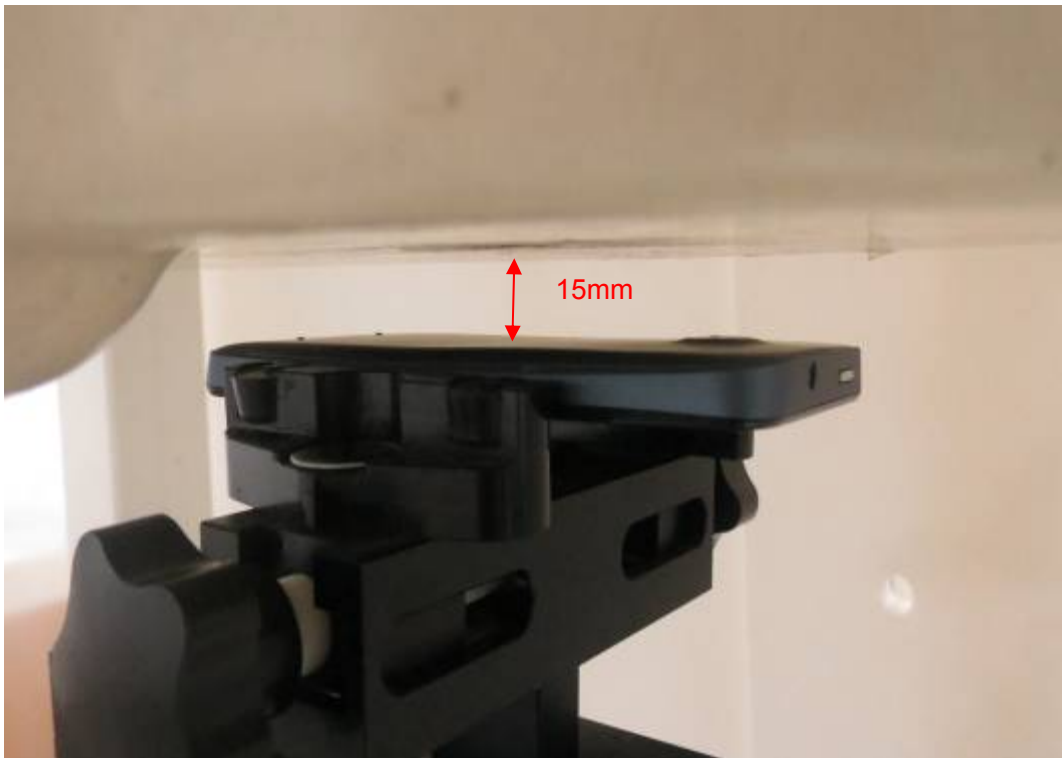

Picture 15: Back Side, the distance from handset to the bottom of the Phantom is 15mm

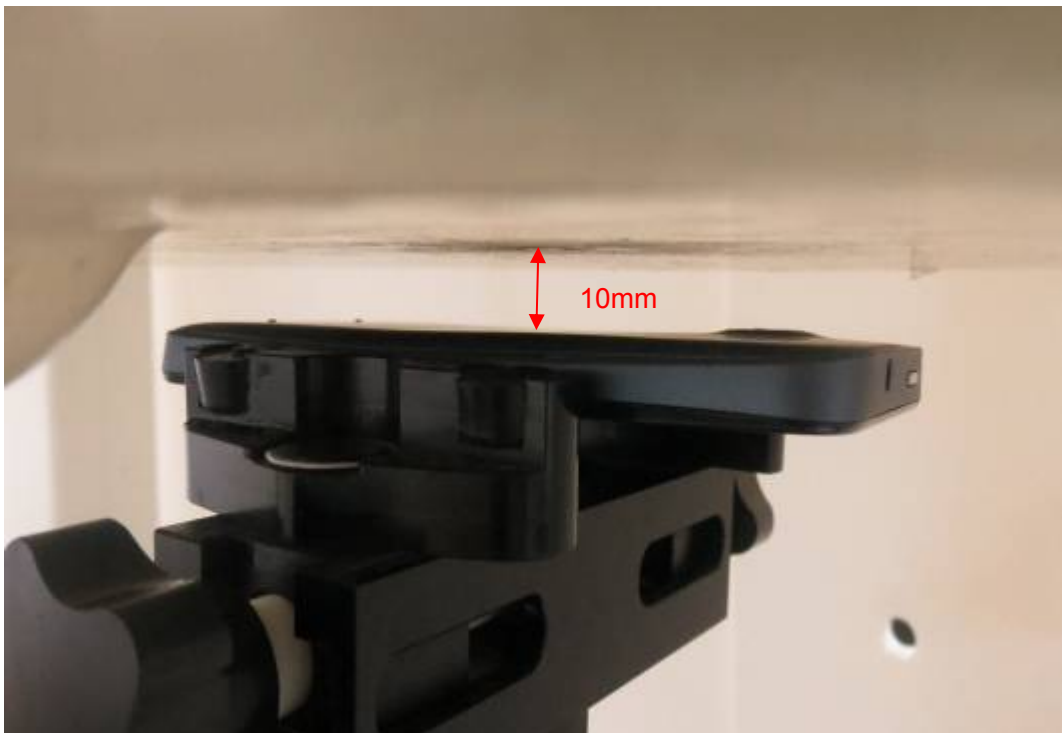

Picture 16: Back Side, the distance from handset to the bottom of the Phantom is 10mm



Picture 17: Front Side, the distance from handset to the bottom of the Phantom is 15mm



Picture 18: Front Side, the distance from handset to the bottom of the Phantom is 10mm

TA Technology (Shanghai) Co., Ltd.
Test Report



Picture 19: Left Edge, the distance from handset to the bottom of the Phantom is 10mm



Picture 20: Right Edge, the distance from handset to the bottom of the Phantom is 10mm

TA Technology (Shanghai) Co., Ltd.
Test Report



Picture 21: Top Edge, the distance from handset to the bottom of the Phantom is 10mm



Picture 22: Bottom Edge, the distance from handset to the bottom of the Phantom is 10mm