



SAR TEST REPORT

No. 2012SAR00035

For

TCT Mobile Limited

GSM quad band mobile phone

Model name: Pond 2SIM

Marketing name: one touch 720D

With

Hardware Version: PIO

Software Version: vP21

FCC ID: RAD235

Issued Date: 2012-03-22



No. DGA-PL-114/01-02

Note:

The test results in this test report relate only to the devices specified in this report. This report shall not be reproduced except in full without the written approval of TMC Beijing.

Test Laboratory:

TMC Beijing, Telecommunication Metrology Center of MIIT

No. 52, Huayuan Bei Road, Haidian District, Beijing, P. R. China 100191.

Tel:+86(0)10-62304633-2079, Fax:+86(0)10-62304633 Email:welcome@emcite.com. www.emcite.com

©Copyright. All rights reserved by TMC Beijing.

Revision Version

Report Number	Revision	Date	Memo
2012SAR00035	00	2012-03-22	Initial creation of test report

TABLE OF CONTENT

1 TEST LABORATORY	5
1.1 TESTING LOCATION	5
1.2 TESTING ENVIRONMENT.....	5
1.3 PROJECT DATA	5
1.4 SIGNATURE.....	5
2 STATEMENT OF COMPLIANCE	6
3 CLIENT INFORMATION.....	7
3.1 APPLICANT INFORMATION	7
3.2 MANUFACTURER INFORMATION	7
4 EQUIPMENT UNDER TEST (EUT) AND ANCILLARY EQUIPMENT (AE)	8
4.1 ABOUT EUT	8
4.2 INTERNAL IDENTIFICATION OF EUT USED DURING THE TEST	8
4.3 INTERNAL IDENTIFICATION OF AE USED DURING THE TEST.....	8
5 TEST METHODOLOGY	9
5.1 APPLICABLE LIMIT REGULATIONS	9
5.2 APPLICABLE MEASUREMENT STANDARDS.....	9
6 SPECIFIC ABSORPTION RATE (SAR).....	10
6.1 INTRODUCTION.....	10
6.2 SAR DEFINITION.....	10
7 SAR MEASUREMENT SETUP	11
7.1 MEASUREMENT SET-UP	11
7.2 DASY4 OR DASY5 E-FIELD PROBE SYSTEM	12
7.3 E-FIELD PROBE CALIBRATION	12
7.4 OTHER TEST EQUIPMENT	13
7.4.1 DATA ACQUISITION ELECTRONICS(DAE)	13
7.4.2 ROBOT.....	14
7.4.3 MEASUREMENT SERVER.....	14
7.4.4 DEVICE HOLDER FOR PHANTOM.....	15
7.4.5 PHANTOM.....	15
8. POSITION OF THE WIRELESS DEVICE IN RELATION TO THE PHANTOM.....	17
8.1 GENERAL CONSIDERATIONS.....	17
8.2 BODY-WORN DEVICE	18
8.3 DESKTOP DEVICE.....	18
8.4 DUT SETUP PHOTOS	20
9 TISSUE SIMULATING LIQUIDS	24
9.1 EQUIVALENT TISSUES.....	24

9.2 DIELECTRIC PERFORMANCE	25
10 SYSTEM VALIDATION	27
10.1 SYSTEM VALIDATION	27
10.2 SYSTEM SETUP	27
11 MEASUREMENT PROCEDURES	29
11.1 TESTS TO BE PERFORMED.....	29
11.2 MEASUREMENT PROCEDURE	30
11.3 BLUETOOTH & WI-FI MEASUREMENT PROCEDURES FOR SAR.....	31
11.4 POWER DRIFT	32
12 CONDUCTED OUTPUT POWER	32
12.1 GSM MEASUREMENT RESULT	32
12.2 WI-FI AND BT MEASUREMENT RESULT	33
13 SIMULTANEOUS TX SAR CONSIDERATIONS	34
13.1 INTRODUCTION.....	34
13.2 TRANSMIT ANTENNA SEPARATION DISTANCES	34
13.3 SIMULTANEOUS TRANSMISSION FOR EUT	34
14 SAR TEST RESULT	36
14.1 THE EVALUATION OF MULTI-BATTERIES	36
14.2 SAR TEST RESULT	36
15 MEASUREMENT UNCERTAINTY	38
16 MAIN TEST INSTRUMENTS	39
ANNEX A GRAPH RESULTS.....	40
ANNEX B SYSTEM VALIDATION RESULTS	92
ANNEX C DIPOLE CALIBRATION CERTIFICATE.....	98
ANNEX D DIPOLE CALIBRATION CERTIFICATE.....	109
ANNEX E SPOT CHECK TEST	136

1 Test Laboratory

1.1 Testing Location

Company Name: TMC Beijing, Telecommunication Metrology Center of MIIT
Address: No 52, Huayuan beilu, Haidian District, Beijing, P.R.China
Postal Code: 100191
Telephone: +86-10-62304633
Fax: +86-10-62304793

1.2 Testing Environment

Temperature: 18°C~25 °C,
Relative humidity: 30%~ 70%
Ground system resistance: < 0.5 Ω
Ambient noise & Reflection: < 0.012 W/kg

1.3 Project Data

Project Leader: Qi Dianyuan
Test Engineer: Lin Xiaojun
Testing Start Date: Feb 26, 2012
Testing End Date: Mar 1st, 2012

1.4 Signature



Lin Xiaojun
(Prepared this test report)

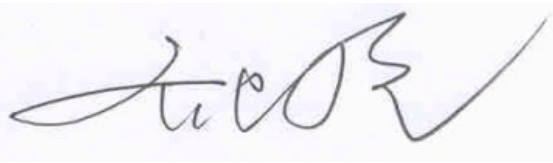

Qi Dianyuan
(Reviewed this test report)



Xiao Li
Deputy Director of the laboratory
(Approved this test report)

2 Statement of Compliance

This EUT is a variant product and the report of original sample is No.2012SAR00026.

According to the client request, we quote the test results of report, No.2012SAR00026, for table 1 and 11 to 18. The results of spot check are presented in the annex E.

The maximum results of Specific Absorption Rate (SAR) found during testing for TCT Mobile Limited GSM quad band mobile phone / one touch 720 are as follows (with expanded uncertainty 18.2%)

Table 1: Max. SAR Measured (1g)

Band	Position	SAR 1g (W/Kg)
GSM 850	Head	0.826
	Body	1.05
GSM 1900	Head	0.771
	Body	0.544
Wi-Fi	Head	0.318
	Body	0.107

The SAR values found for the Mobile Phone are below the maximum recommended levels of 1.6 W/Kg as averaged over any 1g tissue according to the ANSI C95.1-1999.

For body worn operation, this device has been tested and meets FCC RF exposure guidelines when used with any accessory that contains no metal. Use of other accessories may not ensure compliance with FCC RF exposure guidelines.

The measurement together with the test system set-up is described in chapter 7 of this test report. A detailed description of the equipment under test can be found in chapter 3 of this test report.

The maximum SAR value is obtained at the case of **(Table 1)**, and the values are: **1.05 (1g)**.

3 Client Information

3.1 Applicant Information

Company Name: TCT Mobile Limited
Address /Post: 5F, E building, No. 232, Liang Jing Road ZhangJiang High-Tech Park,
Pudong Area Shanghai, P.R. China. 201203
City: ShangHai
Postal Code: 201203
Country: P.R.China
Contact: Gong Zhizhou
Email: zhizhou.gong@jrdcom.com
Telephone: 0086-21-61460890
Fax: 0086-21-61460602

3.2 Manufacturer Information

Company Name: TCT Mobile Limited
Address /Post: 5F, E building, No. 232, Liang Jing Road ZhangJiang High-Tech Park,
Pudong Area Shanghai, P.R. China. 201203
City: ShangHai
Postal Code: 201203
Country: P.R.China
Contact: Gong Zhizhou
Email: zhizhou.gong@jrdcom.com
Telephone: 0086-21-61460890
Fax: 0086-21-61460602

4 Equipment Under Test (EUT) and Ancillary Equipment (AE)

4.1 About EUT

Description:	GSM quad band mobile phone
Model name:	Pond 2SIM
Marketing name:	one touch 720D
Operating mode(s):	GSM 850/900/1800/1900, Wi-Fi, BT 825 – 848.8 MHz (GSM 850)
Tested Tx Frequency:	1850.2 – 1910 MHz (GSM 1900) 2412 – 2462 MHz (Wi-Fi)
GPRS Multislot Class:	12
GPRS capability Class:	B
EGPRS Multislot Class:	/
Test device Production information:	Production unit
Device type:	Portable device
Antenna type:	Integrated antenna
Accessories/Body-worn configurations:	Headset



Picture 4.1: Constituents of the sample

4.2 Internal Identification of EUT used during the test

EUT ID*	SN or IMEI	HW Version	SW Version
EUT1	861567010009575	PIO	vP21

*EUT ID: is used to identify the test sample in the lab internally.

4.3 Internal Identification of AE used during the test

AE ID*	Description	Model	SN	Manufacturer
AE1	Battery	CAB31L0000C1	\	BYD
AE2	Battery	CAB31L0000C2	\	BAK

AE3	Headset	CCB3160A11C1	\	Juwei
AE4	Headset	CCB3160A11C2	\	Shunda
AE5	Headset	CCB3160A15C1	\	Juwei
AE6	Headset	CCB3160A15C2	\	Shunda

*AE ID: is used to identify the test sample in the lab internally. AE3 and AE5 are the same, so they can use the same results. AE4 and AE6 are also the same, so they can use the same results.

5 TEST METHODOLOGY

5.1 Applicable Limit Regulations

ANSI C95.1–1999: IEEE Standard for Safety Levels with Respect to Human Exposure to Radio Frequency Electromagnetic Fields, 3 kHz to 300 GHz.

It specifies the maximum exposure limit of **1.6 W/kg** as averaged over any 1 gram of tissue for portable devices being used within 20 cm of the user in the uncontrolled environment.

5.2 Applicable Measurement Standards

IC RSS-102 ISSUE4: Radio Frequency (RF) Exposure Compliance of Radiocommunication Apparatus (All Frequency Bands)

IEEE 1528–2003: Recommended Practice for Determining the Peak Spatial-Average Specific Absorption Rate (SAR) in the Human Body Due to Wireless Communications Devices: Experimental Techniques.

OET Bulletin 65 (Edition 97-01) and Supplement C(Edition 01-01): Additional Information for Evaluating Compliance of Mobile and Portable Devices with FCC Limits.

KDB648474 D01 SAR Handsets Multi Xmitter and Ant, v01r05: SAR Evaluation Considerations for Handsets with Multiple Transmitters and Antennas.

KDB248227: SAR measurement procedures for 802.112abg transmitters.

KDB941225 : SAR Evaluation Procedures for Portable Devices with Wireless Router Capabilities

6 Specific Absorption Rate (SAR)

6.1 Introduction

SAR is related to the rate at which energy is absorbed per unit mass in an object exposed to a radio field. The SAR distribution in a biological body is complicated and is usually carried out by experimental techniques or numerical modeling. The standard recommends limits for two tiers of groups, occupational/controlled and general population/uncontrolled, based on a person's awareness and ability to exercise control over his or her exposure. In general, occupational/controlled exposure limits are higher than the limits for general population/uncontrolled.

6.2 SAR Definition

The SAR definition is the time derivative (rate) of the incremental energy (dW) absorbed by (dissipated in) an incremental mass (dm) contained in a volume element (dv) of a given density (ρ). The equation description is as below:

$$SAR = \frac{d}{dt} \left(\frac{dW}{dm} \right) = \frac{d}{dt} \left(\frac{dW}{\rho dv} \right)$$

SAR is expressed in units of Watts per kilogram (W/kg)

SAR measurement can be either related to the temperature elevation in tissue by

$$SAR = c \left(\frac{\delta T}{\delta t} \right)$$

Where: C is the specific heat capacity, δT is the temperature rise and δt is the exposure duration, or related to the electrical field in the tissue by

$$SAR = \frac{\sigma |E|^2}{\rho}$$

Where: σ is the conductivity of the tissue, ρ is the mass density of tissue and E is the RMS electrical field strength.

However for evaluating SAR of low power transmitter, electrical field measurement is typically applied.

7 SAR MEASUREMENT SETUP

7.1 Measurement Set-up

The Dasy4 or DASY5 system for performing compliance tests is illustrated above graphically. This system consists of the following items:

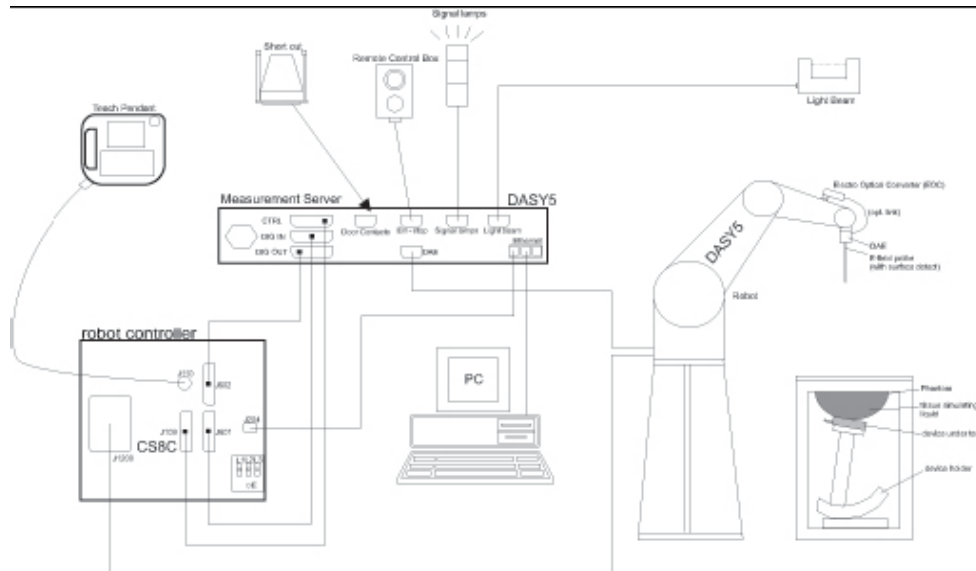

Picture 7.1 SAR Lab Test Measurement Set-up

- A standard high precision 6-axis robot (Stäubli TX=RX family) with controller, teach pendant and software. An arm extension for accommodating the data acquisition electronics (DAE).
- An isotropic field probe optimized and calibrated for the targeted measurement.
- A data acquisition electronics (DAE) which performs the signal amplification, signal multiplexing, AD-conversion, offset measurements, mechanical surface detection, collision detection, etc. The unit is battery powered with standard or rechargeable batteries. The signal is optically transmitted to the EOC.
- The Electro-optical converter (EOC) performs the conversion from optical to electrical signals for the digital communication to the DAE. To use optical surface detection, a special version of the EOC is required. The EOC signal is transmitted to the measurement server.
- The function of the measurement server is to perform the time critical tasks such as signal filtering, control of the robot operation and fast movement interrupts.
- The Light Beam used is for probe alignment. This improves the (absolute) accuracy of the probe positioning.
- A computer running WinXP and the DASY4 or DASY5 software.
- Remote control and teach pendant as well as additional circuitry for robot safety such as
- warning lamps, etc.
- The phantom, the device holder and other accessories according to the targeted measurement.

7.2 Dasy4 or DASY5 E-field Probe System

The SAR measurements were conducted with the dosimetric probe designed in the classical triangular configuration and optimized for dosimetric evaluation. The probe is constructed using the thick film technique; with printed resistive lines on ceramic substrates. The probe is equipped with an optical multifiber line ending at the front of the probe tip. It is connected to the EOC box on the robot arm and provides an automatic detection of the phantom surface. Half of the fibers are connected to a pulsed infrared transmitter, the other half to a synchronized receiver. As the probe approaches the surface, the reflection from the surface produces a coupling from the transmitting to the receiving fibers. This reflection increases first during the approach, reaches maximum and then decreases. If the probe is flatly touching the surface, the coupling is zero. The distance of the coupling maximum to the surface is independent of the surface reflectivity and largely independent of the surface to probe angle. The DASY4 or DASY5 software reads the reflection during a software approach and looks for the maximum using 2nd order curve fitting. The approach is stopped at reaching the maximum.

Probe Specifications:

Model:	ES3DV3, EX3DV4
Frequency	10MHz — 6.0GHz(EX3DV4)
Range:	10MHz — 4GHz(ES3DV3)
Calibration:	In head and body simulating tissue at Frequencies from 835 up to 5800MHz
Linearity:	± 0.2 dB(30 MHz to 6 GHz) for EX3DV4 ± 0.2 dB(30 MHz to 4 GHz) for ES3DV3
Dynamic Range:	10 mW/kg — 100W/kg
Probe Length:	330 mm
Probe Tip	
Length:	20 mm
Body Diameter:	12 mm
Tip Diameter:	2.5 mm (3.9 mm for ES3DV3)
Tip-Center:	1 mm (2.0mm for ES3DV3)
Application:	SAR Dosimetry Testing Compliance tests of mobile phones Dosimetry in strong gradient fields



Picture 7.2 Near-field Probe



Picture 7.3 E-field Probe

7.3 E-field Probe Calibration

Each E-Probe/Probe Amplifier combination has unique calibration parameters. A TEM cell calibration procedure is conducted to determine the proper amplifier settings to enter in the probe parameters. The amplifier settings are determined for a given frequency by subjecting the probe to a known E-field density (1 mW/cm²) using an RF Signal generator, TEM cell, and RF Power Meter.

The free space E-field from amplified probe outputs is determined in a test chamber. This calibration can be performed in a TEM cell if the frequency is below 1 GHz and in a waveguide or other methodologies above 1 GHz for free space. For the free space calibration, the probe is placed

in the volumetric center of the cavity and at the proper orientation with the field. The probe is then rotated 360 degrees until the three channels show the maximum reading. The power density readings equates to 1 mW/ cm²:

E-field temperature correlation calibration is performed in a flat phantom filled with the appropriate simulated brain tissue. The E-field in the medium correlates with the temperature rise in the dielectric medium. For temperature correlation calibration a RF transparent thermistor-based temperature probe is used in conjunction with the E-field probe.

$$SAR = C \frac{\Delta T}{\Delta t}$$

Where:

Δt = Exposure time (30 seconds),

C = Heat capacity of tissue (brain or muscle),

ΔT = Temperature increase due to RF exposure.

$$SAR = \frac{|E|^2 \cdot \sigma}{\rho}$$

Where:

σ = Simulated tissue conductivity,

ρ = Tissue density (kg/m³).

7.4 Other Test Equipment

7.4.1 Data Acquisition Electronics(DAE)

The data acquisition electronics consist of a highly sensitive electrometer-grade preamplifier with auto-zeroing, a channel and gain-switching multiplexer, a fast 16 bit AD-converter and a command decoder with a control logic unit. Transmission to the measurement server is accomplished through an optical downlink for data and status information, as well as an optical uplink for commands and the clock.

The mechanical probe mounting device includes two different sensor systems for frontal and sideways probe contacts. They are used for mechanical surface detection and probe collision detection.

The input impedance of the DAE is 200 MOhm; the inputs are symmetrical and floating. Common mode rejection is above 80 dB.



Picture7.4: DAE

7.4.2 Robot

The SPEAG DASY system uses the high precision robots (DASY4: RX90XL; DASY5: RX160L) type from Stäubli SA (France). For the 6-axis controller system, the robot controller version from Stäubli is used. The Stäubli robot series have many features that are important for our application:

- High precision (repeatability 0.02mm)
- High reliability (industrial design)
- Low maintenance costs (virtually maintenance free due to direct drive gears; no belt drives)
- Jerk-free straight movements (brushless synchron motors; no stepper motors)
- Low ELF interference (motor control fields shielded via the closed metallic construction shields)



Picture 7.5 DASY 4



Picture 7.6 DASY 5

7.4.3 Measurement Server

The Measurement server is based on a PC/104 CPU board with CPU (dasy4: 166 MHz, Intel Pentium; DASY5: 400 MHz, Intel Celeron), chipdisk (DASY4: 32 MB; DASY5: 128MB), RAM (DASY4: 64 MB, DASY5: 128MB). The necessary circuits for communication with the DAE electronic box, as well as the 16 bit AD converter system for optical detection and digital I/O interface are contained on the DASY I/O board, which is directly connected to the PC/104 bus of the CPU board.

The measurement server performs all real-time data evaluation of field measurements and surface detection, controls robot movements and handles safety operation. The PC operating system cannot interfere with these time critical processes. All connections are supervised by a watchdog, and disconnection of any of the cables to the measurement server will automatically disarm the robot and disable all program-controlled robot movements. Furthermore, the measurement server is equipped with an expansion port which is reserved for future applications. Please note that this expansion port does not have a standardized pinout, and therefore only devices provided by SPEAG can be connected. Devices from any other supplier could seriously damage the measurement server.



Picture 7.7 Server for DASY 4



Picture 7.8 Server for DASY 5

7.4.4 Device Holder for Phantom

The SAR in the phantom is approximately inversely proportional to the square of the distance between the source and the liquid surface. For a source at 5mm distance, a positioning uncertainty of $\pm 0.5\text{mm}$ would produce a SAR uncertainty of $\pm 20\%$. Accurate device positioning is therefore crucial for accurate and repeatable measurements. The positions in which the devices must be measured are defined by the standards.

The DASY device holder is designed to cope with the different positions given in the standard. It has two scales for device rotation (with respect to the body axis) and device inclination (with respect to the line between the ear reference points). The rotation centers for both scales is the ear reference point (ERP). Thus the device needs no repositioning when changing the angles.

The DASY device holder is constructed of low-loss

POM material having the following dielectric

parameters: relative permittivity $\epsilon = 3$ and loss tangent $\delta = 0.02$. The amount of dielectric material has been reduced in the closest vicinity of the device, since measurements have suggested that the influence of the clamp on the test results could thus be lowered.

<Laptop Extension Kit>

The extension is lightweight and made of POM, acrylic glass and foam. It fits easily on the upper part of the Mounting Device in place of the phone positioner. The extension is fully compatible with the Twin-SAM and ELI phantoms.



Picture 7.9-1: Device Holder

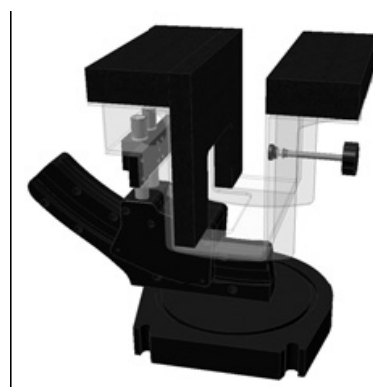

Picture 7.9-2: Laptop Extension Kit

7.4.5 Phantom

The SAM Twin Phantom V4.0 is constructed of a fiberglass shell integrated in a table. The shape of the shell is based on data from an anatomical study designed to

Represent the 90th percentile of the population. The phantom enables the dissymmetric evaluation

of SAR for both left and right handed handset usage, as well as body-worn usage using the flat phantom region. Reference markings on the Phantom allow the complete setup of all predefined phantom positions and measurement grids by manually teaching three points in the robot. The shell phantom has a 2mm shell thickness (except the ear region where shell thickness increases to 6 mm).

Shell Thickness: 2 ± 0.2 mm

Filling Volume: Approx. 25 liters

Dimensions: 810 x 1000 x 500 mm (H x L x W)

Available: Special



Picture 7.10: SAM Twin Phantom

8. Position of the wireless device in relation to the phantom

8.1 General considerations

This standard specifies two handset test positions against the head phantom – the “cheek” position and the “tilt” position.

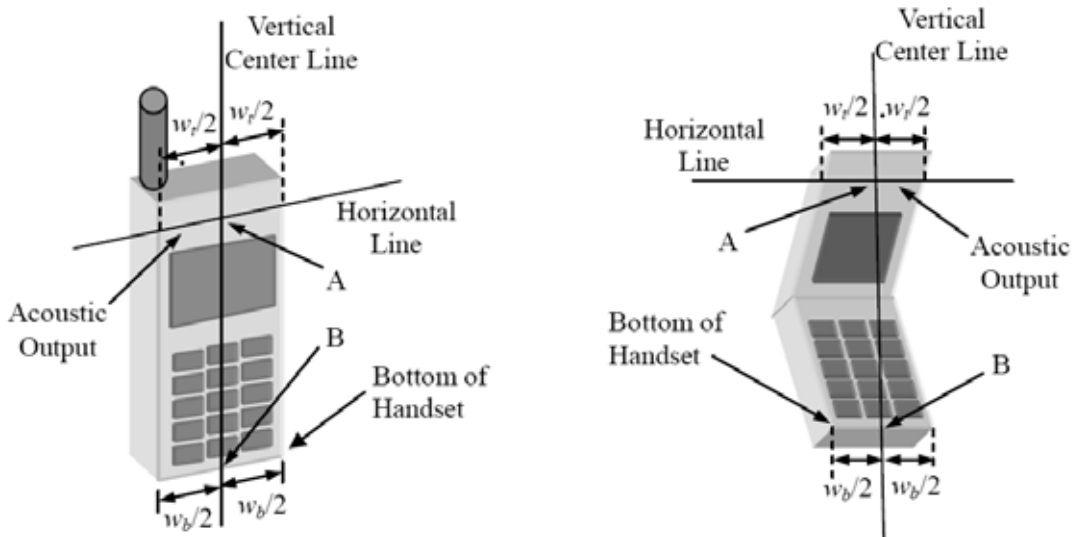

- w_t Width of the handset at the level of the acoustic
- w_b Width of the bottom of the handset
- A Midpoint of the width w_t of the handset at the level of the acoustic output
- B Midpoint of the width w_b of the bottom of the handset

Picture 8.1-a Typical “fixed” case handset Picture 8.1-b Typical “clam-shell” case handset

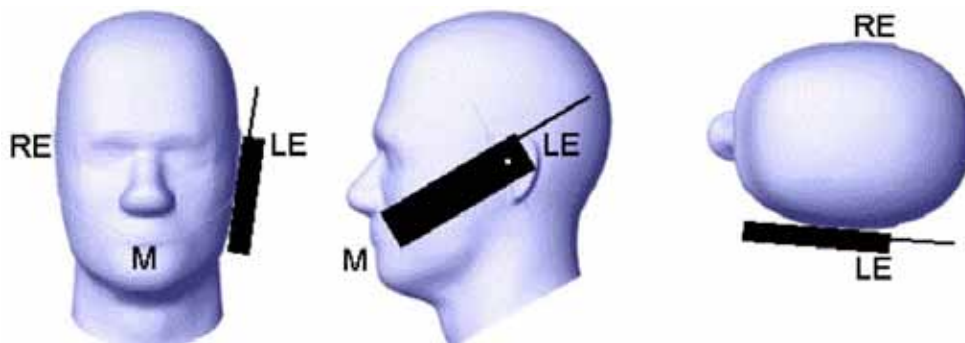

Picture 8.2 Cheek position of the wireless device on the left side of SAM

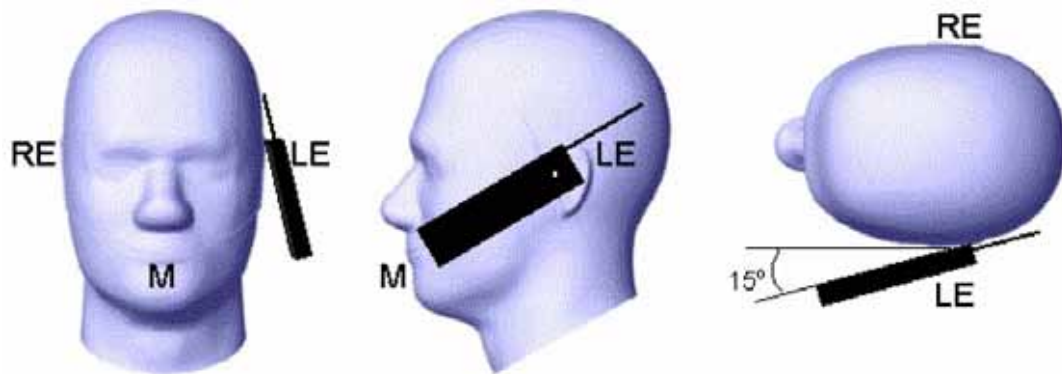

Picture 8.3 Tilt position of the wireless device on the left side of SAM

8.2 Body-worn device

A typical example of a body-worn device is a mobile phone, wireless enabled PDA or other battery operated wireless device with the ability to transmit while mounted on a person's body using a carry accessory approved by the wireless device manufacturer.

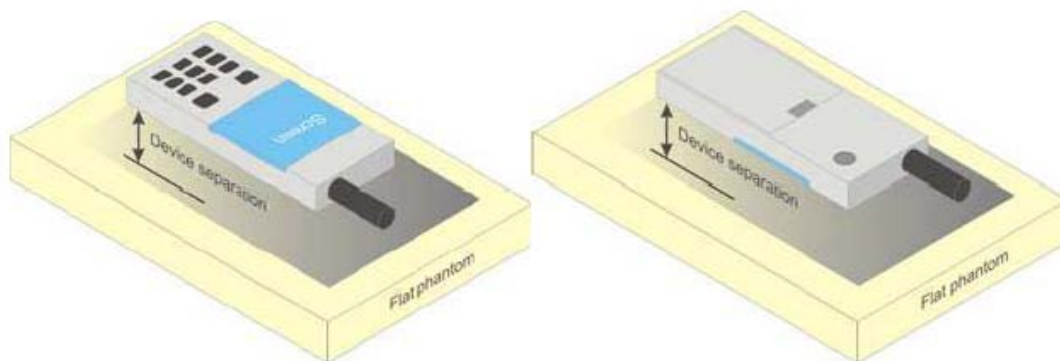

Picture 8.4 Test positions for body-worn devices

8.3 Desktop device

A typical example of a desktop device is a wireless enabled desktop computer placed on a table or desk when used.

The DUT shall be positioned at the distance and in the orientation to the phantom that corresponds to the intended use as specified by the manufacturer in the user instructions. For devices that employ an external antenna with variable positions, tests shall be performed for all antenna positions specified. Picture 8.5 show positions for desktop device SAR tests. If the intended use is not specified, the device shall be tested directly against the flat phantom.

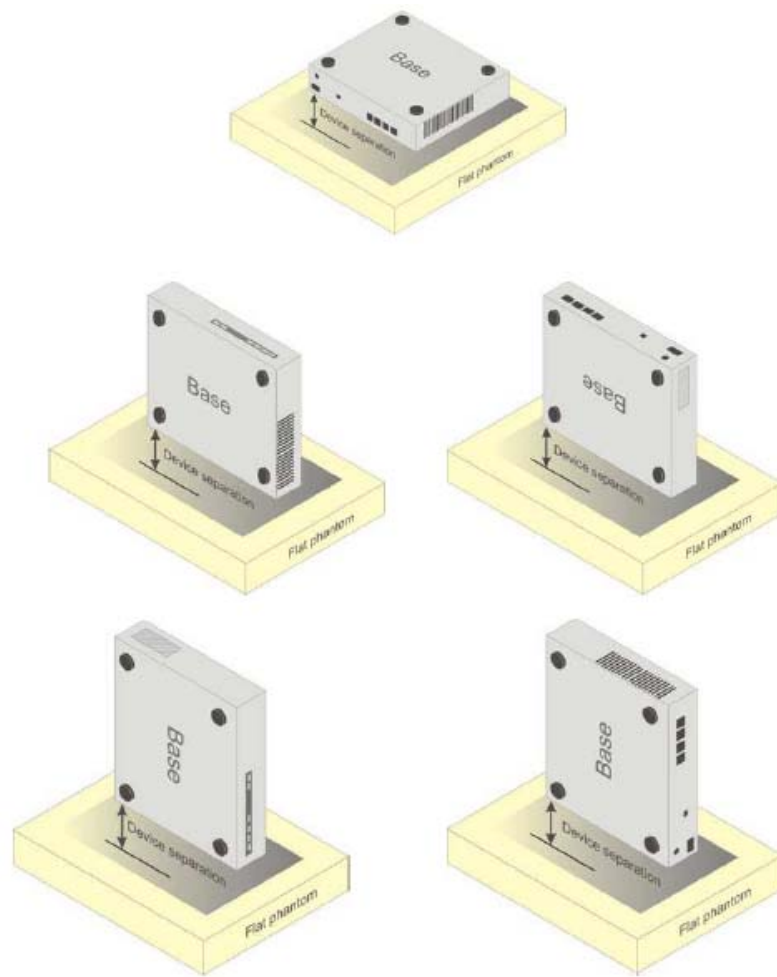

Picture 8.5 Test positions for desktop devices

8.4 DUT Setup Photos**Picture 8.6****Picture 8.7: Left Hand Touch Cheek Position**



Picture 8.8: Left Hand Tilt 15° Position



Picture 8.9: Right Hand Touch Cheek Position



Picture 8.10: Right Hand Tilt 15° Position

Test positions for body:

The Body SAR is tested at the following 2 test positions all with the distance =15mm between the EUT and the phantom bottom :

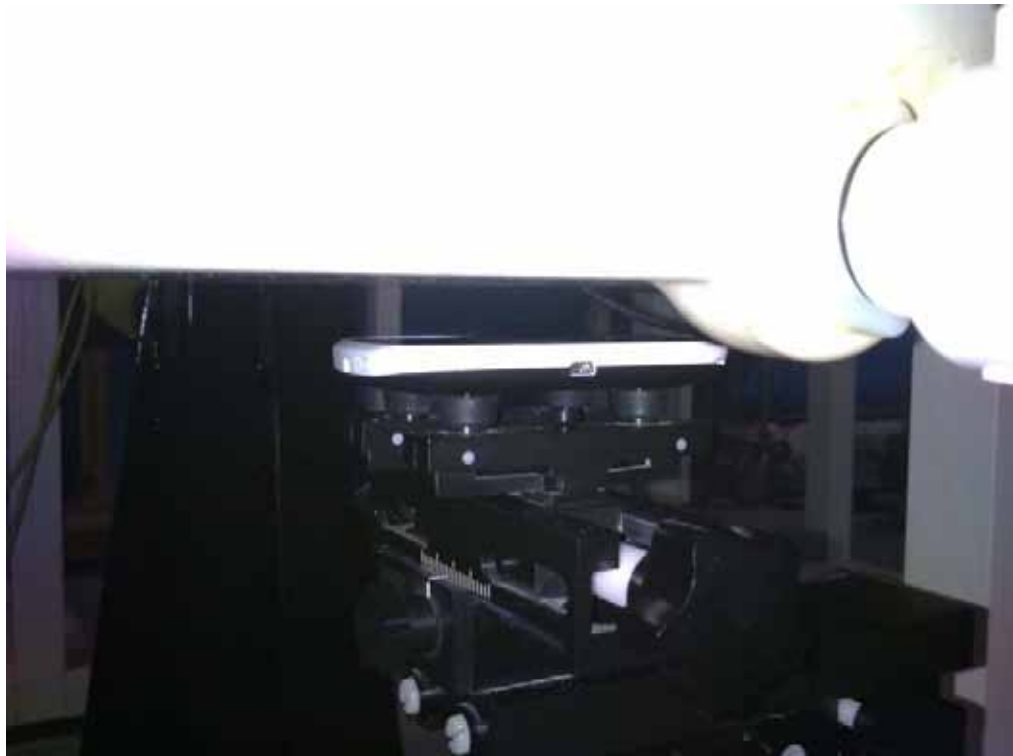

Picture 8.11: Forward Surface



Picture 8.12: Back Surface



Picture 8.13: Back Surface with Headset



Picture 8.14: Surface with Headset

9 Tissue Simulating Liquids

9.1 Equivalent Tissues

The liquid used for the frequency range of 800-3000 MHz consisted of water, sugar, salt, preventol, glycol monobutyl and Cellulose. The liquid has been previously proven to be suited for worst-case. The Table 1 and 2 shows the detail solution. It's satisfying the latest tissue dielectric parameters requirements proposed by the IEEE 1528 and IEC 62209.

Table 2. Composition of the Tissue Equivalent Matter

Frequency (MHz)	835 Head	835 Body	1900 Head	1900 Body	2450 Head	2450 Body
Ingredients (% by weight)						
Water	41.45	52.5	55.242	69.91	58.79	72.60
Sugar	56.0	45.0	\	\	\	\
Salt	1.45	1.4	0.306	0.13	0.06	0.18
Preventol	0.1	0.1	\	\	\	\
Cellulose	1.0	1.0	\	\	\	\
Glycol Monobutyl	\	\	44.452	29.96	41.15	27.22
Dielectric Parameters	$\epsilon=41.5$	$\epsilon=55.2$	$\epsilon=40.0$	$\epsilon=53.3$	$\epsilon=39.2$	$\epsilon=52.7$
Target Value	$\sigma=0.90$	$\sigma=0.97$	$\sigma=1.40$	$\sigma=1.52$	$\sigma=1.80$	$\sigma=1.95$

Table 3. Targets for tissue simulating liquid

Frequency (MHz)	Liquid Type	Conductivity (σ)	$\pm 5\%$ Range	Permittivity (ϵ)	$\pm 5\%$ Range
835	Head	0.90	0.86~0.95	41.5	39.4~43.6
835	Body	0.97	0.92~1.02	55.2	52.4~58.0
1900	Head	1.40	1.33~1.47	40.0	38.0~42.0
1900	Body	1.52	1.44~1.60	53.3	50.6~56.0
2450	Head	1.80	1.71~1.89	39.2	37.2~41.2
2450	Body	1.95	1.85~2.05	52.7	50.1~55.3

9.2 Dielectric Performance

Table 4: Dielectric Performance of Tissue Simulating Liquid

Measurement is made at temperature 23.0 °C and relative humidity 38%.				
Liquid temperature during the test: 22.5°C				
Measurement Date : 835 MHz Feb 29, 2012 1900 MHz Mar 1st, 2012 2450 MHz Feb 26, 2012				
/	Type	Frequency	Permittivity ϵ	Conductivity σ (S/m)
Measurement value	Head	835 MHz	42.5	0.91
	Body	835 MHz	53.7	0.97
	Head	1900 MHz	40.5	1.39
	Body	1900 MHz	53.2	1.50
	Head	2450 MHz	38.5	1.82
	Body	2450 MHz	51.9	1.96

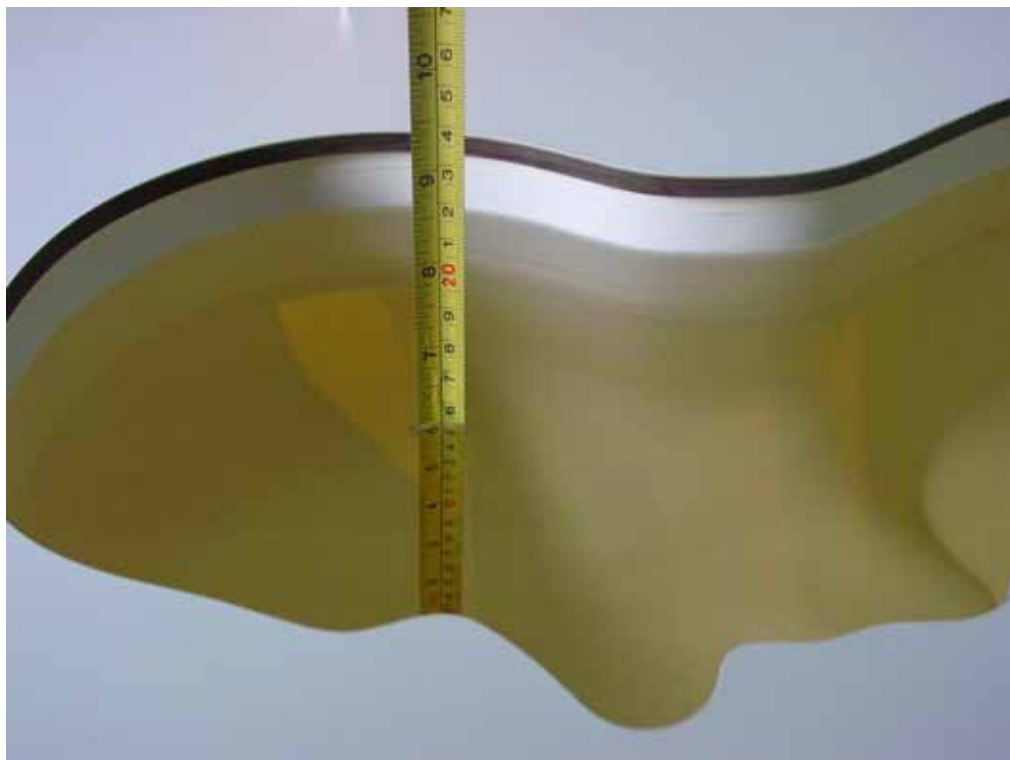

Picture 9.1: Liquid depth in the Head Phantom (850 MHz)



Picture 9.2 Liquid depth in the Flat Phantom (1900MHz)



Picture 9.3 Liquid depth in the Flat Phantom (2450MHz)

10 System Validation

10.1 System Validation

Each DASY system is equipped with one or more system validation kits. These units, together with the predefined measurement procedures within the DASY software, enable the user to conduct the system performance check and system validation. System validation kit includes a dipole, tripod holder to fix it underneath the flat phantom and a corresponding distance holder.

10.2 System Setup

In the simplified setup for system evaluation, the DUT is replaced by a calibrated dipole and the power source is replaced by a continuous wave that comes from a signal generator. The calibrated dipole must be placed beneath the flat phantom section of the SAM twin phantom with the correct distance holder. The distance holder should touch the phantom surface with a light pressure at the reference marking and be oriented parallel to the long side of the phantom. The equipment setup is shown below:

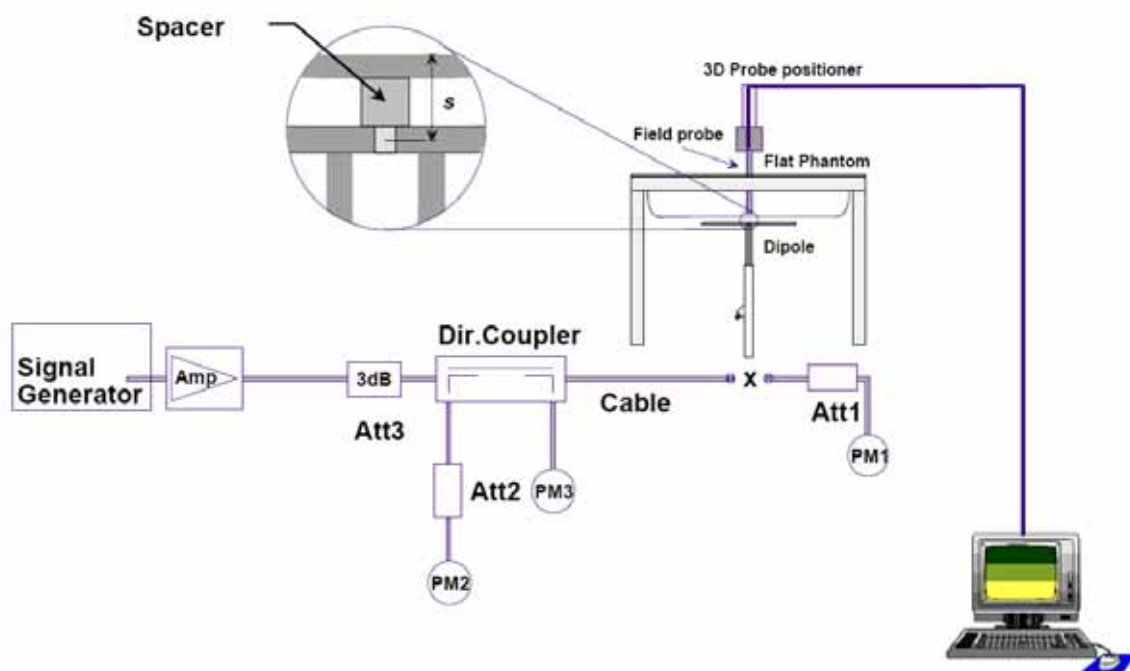

Picture 10.1 System Setup for System Evaluation

The output power on dipole port must be calibrated to 24 dBm (250mW) before dipole is connected.



Picture 10.2 Photo of Dipole Setup

Table 5: System Validation of Head

Measurement is made at temperature 23.0 °C and relative humidity 38%.							
Liquid temperature during the test: 22.5°C							
Measurement Date: 835 MHz Feb 29, 2012 1900 MHz Mar 1st, 2012 2450 MHz Feb 26, 2012							
Verification results	Frequency	Target value (W/kg)		Measured value (W/kg)		Deviation	
		10 g Average	1 g Average	10 g Average	1 g Average	10 g Average	1 g Average
	835 MHz	6.12	9.41	6.12	9.16	0.00%	-2.66%
	1900 MHz	20.1	39.4	19.96	38.72	-0.70%	-1.73%
2450 MHz	24.6	52.4	23.92	51.60	-2.76%	-1.53%	

Table 6: System Validation of Body

Measurement is made at temperature 23.0 °C and relative humidity 38%.							
Liquid temperature during the test: 22.5°C							
Measurement Date: 835 MHz Feb 29, 2012 1900 MHz Mar 1st, 2012 2450 MHz Feb 26, 2012							
Verification results	Frequency	Target value (W/kg)		Measured value (W/kg)		Deviation	
		10 g Average	1 g Average	10 g Average	1 g Average	10 g Average	1 g Average
	835 MHz	6.24	9.57	6.04	9.28	-3.21%	-3.03%
	1900 MHz	20.9	41.4	20.44	40.80	-2.20%	-1.45%
2450 MHz	23.9	51.6	23.20	51.20	-2.93%	-0.78%	

11 Measurement Procedures

11.1 Tests to be performed

In order to determine the highest value of the peak spatial-average SAR of a handset, all device positions, configurations and operational modes shall be tested for each frequency band according to steps 1 to 3 below. A flowchart of the test process is shown in Picture 11.1.

Step 1: The tests described in 11.2 shall be performed at the channel that is closest to the centre of the transmit frequency band (f_c) for:

- a) all device positions (cheek and tilt, for both left and right sides of the SAM phantom, as described in Chapter 8),
- b) all configurations for each device position in a), e.g., antenna extended and retracted, and
- c) all operational modes, e.g., analogue and digital, for each device position in a) and configuration in b) in each frequency band.

If more than three frequencies need to be tested according to 11.1 (i.e., $N_c > 3$), then all frequencies, configurations and modes shall be tested for all of the above test conditions.

Step 2: For the condition providing highest peak spatial-average SAR determined in Step 1, perform all tests described in 11.2 at all other test frequencies, i.e., lowest and highest frequencies. In addition, for all other conditions (device position, configuration and operational mode) where the peak spatial-average SAR value determined in Step 1 is within 3 dB of the applicable SAR limit, it is recommended that all other test frequencies shall be tested as well.

Step 3: Examine all data to determine the highest value of the peak spatial-average SAR found in Steps 1 to 2.

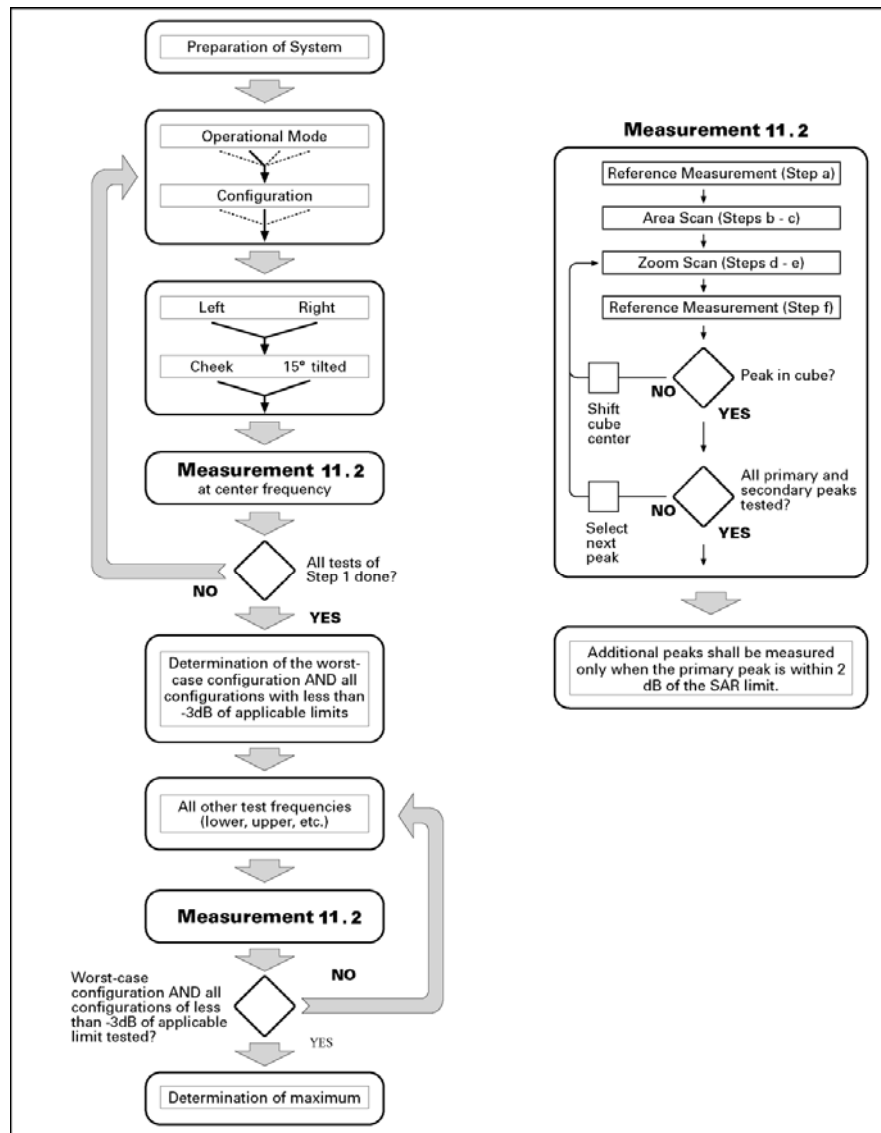

Picture 11.1 Block diagram of the tests to be performed

11.2 Measurement procedure

The following procedure shall be performed for each of the test conditions (see Picture 11.1) described in 11.1:

- a) Measure the local SAR at a test point within 8 mm or less in the normal direction from the inner surface of the phantom.
- b) Measure the two-dimensional SAR distribution within the phantom (area scan procedure). The boundary of the measurement area shall not be closer than 20 mm from the phantom side walls. The distance between the measurement points should enable the detection of the location of local maximum with an accuracy of better than half the linear dimension of the tissue cube after interpolation. A maximum grid spacing of 20 mm for frequencies below 3 GHz and $(60/f \text{ [GHz]})$ mm for frequencies of 3GHz and greater is recommended. The maximum distance between the geometrical centre of the probe detectors and the inner surface of the phantom shall be 5 mm for frequencies below 3 GHz and $\delta \ln(2)/2$ mm for frequencies of 3 GHz and greater, where δ is the plane wave skin depth and $\ln(x)$ is the natural logarithm. The maximum variation of the

sensor-phantom surface shall be ± 1 mm for frequencies below 3 GHz and ± 0.5 mm for frequencies of 3 GHz and greater. At all measurement points the angle of the probe with respect to the line normal to the surface should be less than 5° . If this cannot be achieved for a measurement distance to the phantom inner surface shorter than the probe diameter, additional uncertainty evaluation is needed.

c) From the scanned SAR distribution, identify the position of the maximum SAR value, in addition identify the positions of any local maxima with SAR values within 2 dB of the maximum value that are not within the zoom-scan volume; additional peaks shall be measured only when the primary peak is within 2 dB of the SAR limit. This is consistent with the 2 dB threshold already stated;

d) Measure the three-dimensional SAR distribution at the local maxima locations identified in step c). The horizontal grid step shall be $(24/f[\text{GHz}])$ mm or less but not more than 8 mm. The minimum zoom size of 30 mm by 30 mm and 30 mm for frequencies below 3 GHz. For higher frequencies, the minimum zoom size of 22 mm by 22 mm and 22 mm. The grid step in the vertical direction shall be $(8-f[\text{GHz}])$ mm or less but not more than 5 mm, if uniform spacing is used. If variable spacing is used in the vertical direction, the maximum spacing between the two closest measured points to the phantom shell shall be $(12 / f[\text{GHz}])$ mm or less but not more than 4 mm, and the spacing between further points shall increase by an incremental factor not exceeding 1.5. When variable spacing is used, extrapolation routines shall be tested with the same spacing as used in measurements. The maximum distance between the geometrical centre of the probe detectors and the inner surface of the phantom shall be 5 mm for frequencies below 3 GHz and $\delta \ln(2)/2$ mm for frequencies of 3 GHz and greater, where δ is the plane wave skin depth and $\ln(x)$ is the natural logarithm. Separate grids shall be centered on each of the local SAR maxima found in step c). Uncertainties due to field distortion between the media boundary and the dielectric enclosure of the probe should also be minimized, which is achieved if the distance between the phantom surface and physical tip of the probe is larger than probe tip diameter. Other methods may utilize correction procedures for these boundary effects that enable high precision measurements closer than half the probe diameter. For all measurement points, the angle of the probe with respect to the flat phantom surface shall be less than 5° . If this cannot be achieved an additional uncertainty evaluation is needed.

e) Use post processing (e.g. interpolation and extrapolation) procedures to determine the local SAR values at the spatial resolution needed for mass averaging.

11.3 Bluetooth & Wi-Fi Measurement Procedures for SAR

Normal network operating configurations are not suitable for measuring the SAR of 802.11 transmitters in general. Unpredictable fluctuations in network traffic and antenna diversity conditions can introduce undesirable variations in SAR results. The SAR for these devices should be measured using chipset based test mode software to ensure that the results are consistent and reliable.

Chipset based test mode software is hardware dependent and generally varies among manufacturers. The device operating parameters established in a test mode for SAR measurements must be identical to those programmed in production units, including output power levels, amplifier gain settings and other RF performance tuning parameters. The test frequencies should correspond to actual channel frequencies defined for domestic use. SAR for devices with switched diversity should be measured with only one antenna transmitting at a time during each SAR measurement, according to a fixed modulation and data rate. The same data pattern should be used for all

measurements.

11.4 Power Drift

To control the output power stability during the SAR test, DASY5 system calculates the power drift by measuring the E-field at the same location at the beginning and at the end of the measurement for each test position. These drift values can be found in Table 13 to Table 18 labeled as: (Power Drift [dB]). This ensures that the power drift during one measurement is within 5%.

12 Conducted Output Power

12.1 GSM Measurement result

During the process of testing, the EUT was controlled via Rhode & Schwarz Digital Radio Communication tester (CMU-200) to ensure the maximum power transmission and proper modulation. This result contains conducted output power for the EUT. In all cases, the measured peak output power should be greater and within 5% than EMI measurement.

Table 7: The conducted power measurement results for GSM850/1900

GSM 850MHZ	Conducted Power (dBm)		
	Channel 251(848.8MHz)	Channel 190(836.6MHz)	Channel 128(824.2MHz)
	32.41	32.48	32.56
GSM 1900MHZ	Conducted Power (dBm)		
	Channel 810(1909.8MHz)	Channel 661(1800MHz)	Channel 512(1850.2MHz)
	29.61	29.56	29.51

Table 8: The conducted power measurement results for GPRS

GSM 850 GPRS	Measured Power (dBm)			calculation	Averaged Power (dBm)		
	251	190	128		251	190	128
1 Txslot	32.27	32.35	32.41	-9.03dB	23.24	23.32	23.38
2 Txslots	31.50	31.60	31.68	-6.02dB	25.48	25.58	25.66
3Txslots	30.86	30.92	31.00	-4.26dB	26.60	26.66	26.74
4 Txslots	30.16	30.22	30.31	-3.01dB	27.15	27.21	27.3
PCS1900 GPRS	Measured Power (dBm)			calculation	Averaged Power (dBm)		
	810	661	512		810	661	512
1 Txslot	29.49	29.44	29.38	-9.03dB	20.46	20.41	20.35
2 Txslots	29.08	29.02	28.97	-6.02dB	23.06	23.00	22.95
3Txslots	28.62	28.57	28.54	-4.26dB	24.36	24.31	24.28
4 Txslots	27.71	27.64	27.6	-3.01dB	24.70	24.63	24.59

NOTES:

1) Division Factors

To average the power, the division factor is as follows:

1TX-slot = 1 transmit time slot out of 8 time slots=> conducted power divided by (8/1) => -9.03dB

2TX-slots = 2 transmit time slots out of 8 time slots=> conducted power divided by (8/2) => -6.02dB

3TX-slots = 3 transmit time slots out of 8 time slots=> conducted power divided by (8/3) => -4.26dB

4TX-slots = 4 transmit time slots out of 8 time slots=> conducted power divided by (8/4) => -3.01dB

According to the conducted power as above, the body measurements are performed with 4Txslots for GSM850 and GSM1900.

12.2 Wi-Fi and BT Measurement result

The output power of BT antenna is The output power of BT antenna is 7.80dBm.

The average conducted power for WiFi is as following:

802.11b (dBm)

Channel\data rate	1Mbps	2Mbps	5.5Mbps	11Mbps
1	13.39	13.14	13.07	13.02
6	13.74	13.71	13.44	13.43
11	13.89	13.94	13.88	13.94

802.11g (dBm)

Channel\data rate	6Mbps	9Mbps	12Mbps	18Mbps	24Mbps	36Mbps	48Mbps	54Mbps
1	11.73	11.20	11.16	11.13	11.35	11.25	11.16	11.12
6	11.57	11.59	11.56	11.61	11.54	11.52	11.49	11.50
11	11.94	12.00	12.00	11.99	11.94	11.99	12.00	12.02

The peak conducted power for WiFi is as following:

802.11b (dBm)

Channel\data rate	1Mbps	2Mbps	5.5Mbps	11Mbps
1	16.76	17.00	18.23	19.77
6	/	/	/	20.48
11	/	/	/	21.10

802.11g (dBm)

Channel\data rate	6Mbps	9Mbps	12Mbps	18Mbps	24Mbps	36Mbps	48Mbps	54Mbps
1	19.78	19.76	19.57	19.56	20.00	19.97	20.05	20.03
6	/	/		/	/	/	20.79	/
11	/	/		/	/	/	21.39	/

SAR is not required for 802.11g channels if the output power is less than 0.25dB higher than that measured on the corresponding 802.11b channels, and for each frequency band, testing at higher data rates and higher order modulations is not required when the maximum average output power for each of these configurations is less than 0.25dB higher than those measured at the lowest data rate. According to the above conducted power, the EUT should be tested for "802.11b, 1Mbps, channel 11".

13 Simultaneous TX SAR Considerations

13.1 Introduction

The following procedures adopted from “FCC SAR Considerations for Cell Phones with Multiple Transmitters” are applicable to handsets with built-in unlicensed transmitters such as 802.11 a/b/g and Bluetooth devices which may simultaneously transmit with the licensed transmitter.

For this device, the BT and WiFi can transmit simultaneous with other transmitters.

13.2 Transmit Antenna Separation Distances



Picture 13.1 Antenna Locations

13.3 Simultaneous Transmission for EUT

Table 9: Summary of Transmitters

Band/Mode	F(GHz)	60/f power threshold (mW)	RF output power (mW)
Bluetooth	2.441	24.6	6.03
2.4GHz WLAN 802.11 b/g	2.45	24.5	24.5

According to the conducted power measurement result, we can draw the conclusion that: stand-alone SAR for WiFi should be performed. Then, simultaneous transmission SAR for WiFi is considered with measurement results of GSM and WiFi. Stand-alone SAR and simultaneous transmission SAR for Bluetooth should not be performed.

Table 10 SAR Evaluation Requirements for Multiple Transmitter Handsets

	Individual Transmitter	Simultaneous Transmission
Licensed Transmitters	Routine evaluation required	SAR not required:
Unlicensed Transmitters	<p>When there is no simultaneous transmission –</p> <ul style="list-style-type: none"> output $\leq 60/f$: SAR not required output $> 60/f$: stand-alone SAR required <p>When there is simultaneous transmission –</p> <p><u>Stand-alone SAR not required when</u></p> <ul style="list-style-type: none"> output $\leq 2 \cdot P_{Ref}$ and antenna is ≥ 5.0 cm from other antennas output $\leq P_{Ref}$ and antenna is ≥ 2.5 cm from other antennas output $\leq P_{Ref}$ and antenna is < 2.5 cm from other antennas, each with either output power $\leq P_{Ref}$ or 1-g SAR < 1.2 W/kg <p><u>Otherwise stand-alone SAR is required</u></p> <p>When stand-alone SAR is required</p> <ul style="list-style-type: none"> test SAR on highest output channel for each wireless mode and exposure condition if SAR for highest output channel is $> 50\%$ of SAR limit, evaluate all channels according to normal procedures 	<p>Unlicensed only</p> <ul style="list-style-type: none"> when stand-alone 1-g SAR is not required and antenna is ≥ 5 cm from other antennas <p><u>Licensed & Unlicensed</u></p> <ul style="list-style-type: none"> when the sum of the 1-g SAR is < 1.6 W/kg for all simultaneous transmitting antennas when SAR to peak location separation ratio of simultaneous transmitting antenna pair is < 0.3 <p>SAR required:</p> <p><u>Licensed & Unlicensed</u></p> <p>antenna pairs with SAR to peak location separation ratio ≥ 0.3; test is only required for the configuration that results in the highest SAR in stand-alone configuration for each wireless mode and exposure condition</p> <p>Note: simultaneous transmission exposure conditions for head and body can be different for different style phones; therefore, different test requirements may apply</p>

See below for simultaneous transmission logic table:

	GSM	Wi-Fi	BT
GSM		Yes	Yes
Wi-Fi	Yes		No
BT	Yes	No	

Since the output power of Bluetooth and WiFi are less than $60/f$ and the antenna is > 5.0 cm from other antennas, simultaneous transmission SAR for WiFi is not required.

14 SAR Test Result

14.1 The evaluation of multi-batteries

We'll perform the head measurement in all bands with the primary battery depending on the evaluation of multi-batteries and retest on highest value point with other batteries. Then, repeat the measurement in the Body test.

Table 11: The evaluation of multi-batteries for Head Test

Frequency		Mode/Band	Side	Test Position	Battery Type	SAR(1g)	Power Drift(dB)
MHz	Ch.					(W/kg)	
848.8	251	GSM850	Right	Touch	CAB31L0000C2	0.812	-0.10
848.8	251	GSM850	Right	Touch	CAB31L0000C1	0.826	0.05

Note: According to the values in the above table, the battery, CAB31L0000C1, is the primary battery. We'll perform the head measurement with this battery and retest on highest value point with others.

Table 12: The evaluation of multi-batteries for Body Test

Frequency		Mode/Band	Headset	Test Position	Spacing (mm)	Battery Type	SAR(1g)	Power Drift(dB)
MHz	Ch.						(W/kg)	
848.8	251	GPRS	\	Ground	15	CAB31L0000C2	1.01	-0.10
848.8	251	GPRS	\	Ground	15	CAB31L0000C1	1.05	-0.12

Note: According to the values in the above table, the battery, CAB31L0000C1, is the primary battery. We'll perform the Body measurement with this battery and retest on highest value point with others.

14.2 SAR Test Result

Table 13: SAR Values (GSM 850 MHz Band - Head)

Frequency		Mode/Band	Side	Test Position	Battery Type	SAR(1g)	Power Drift(dB)
MHz	Ch.					(W/kg)	
848.8	251	GSM850	Left	Touch	CAB31L0000C1	0.826	0.05
836.6	190	GSM850	Left	Touch	CAB31L0000C1	0.693	0.15
824.2	128	GSM850	Left	Touch	CAB31L0000C1	0.624	0.06
848.8	251	GSM850	Left	Tilt	CAB31L0000C1	0.336	-0.02
836.6	190	GSM850	Left	Tilt	CAB31L0000C1	0.309	0.06
824.2	128	GSM850	Left	Tilt	CAB31L0000C1	0.280	-0.04
848.8	251	GSM850	Right	Touch	CAB31L0000C1	0.763	0.04
836.6	190	GSM850	Right	Touch	CAB31L0000C1	0.691	0.04
824.2	128	GSM850	Right	Touch	CAB31L0000C1	0.581	-0.0077
848.8	251	GSM850	Right	Tilt	CAB31L0000C1	0.383	-0.10
836.6	190	GSM850	Right	Tilt	CAB31L0000C1	0.345	-0.0056
824.2	128	GSM850	Right	Tilt	CAB31L0000C1	0.286	-0.10

Table 14: SAR Values (GSM 850 MHz Band - Body)

Frequency		Mode/ Band	Headset	Test Position	Spacing (mm)	Battery Type	SAR(1g)	Power Drift(dB)
MHz	Ch.						(W/kg)	
848.8	251	GPRS	\	Phantom	15	CAB31L0000C1	0.991	-0.19
836.6	190	GPRS	\	Phantom	15	CAB31L0000C1	0.919	-0.01
824.2	128	GPRS	\	Phantom	15	CAB31L0000C1	0.863	-0.03
848.8	251	GPRS	\	Ground	15	CAB31L0000C1	1.05	-0.12
836.6	190	GPRS	\	Ground	15	CAB31L0000C1	1	0.0085
824.2	128	GPRS	\	Ground	15	CAB31L0000C1	0.958	0.06
848.8	251	Speech	CCB316 0A11C1	Ground	15	CAB31L0000C1	0.497	0.04
848.8	251	Speech	CCB316 0A11C2	Ground	15	CAB31L0000C1	0.358	0.04

Table 15: SAR Values (GSM 1900 MHz Band - Head)

Frequency		Mode/Band	Side	Test Position	Battery Type	SAR(1g)	Power Drift(dB)
MHz	Ch.					(W/kg)	
1909.8	810	GSM1900	Left	Touch	CAB31L0000C1	0.555	-0.04
1880	661	GSM1900	Left	Touch	CAB31L0000C1	0.561	0.02
1850.2	512	GSM1900	Left	Touch	CAB31L0000C1	0.555	0.04
1909.8	810	GSM1900	Left	Tilt	CAB31L0000C1	0.264	0.03
1880	661	GSM1900	Left	Tilt	CAB31L0000C1	0.305	0.04
1850.2	512	GSM1900	Left	Tilt	CAB31L0000C1	0.308	0.04
1909.8	810	GSM1900	Right	Touch	CAB31L0000C1	0.715	0.05
1880	661	GSM1900	Right	Touch	CAB31L0000C1	0.771	-0.07
1850.2	512	GSM1900	Right	Touch	CAB31L0000C1	0.729	0.07
1909.8	810	GSM1900	Right	Tilt	CAB31L0000C1	0.252	-0.01
1880	661	GSM1900	Right	Tilt	CAB31L0000C1	0.275	0.0063
1850.2	512	GSM1900	Right	Tilt	CAB31L0000C1	0.263	0.02

Table 16: SAR Values (GSM 1900 MHz Band - Body)

Frequency		Mode/ Band	Headset	Test Position	Spacing (mm)	Battery Type	SAR(1g)	Power Drift(dB)
MHz	Ch.						(W/kg)	
1909.8	810	GPRS	\	Phantom	15	CAB31L0000C1	0.442	-0.05
1880	661	GPRS	\	Phantom	15	CAB31L0000C1	0.482	-0.0013
1850.2	512	GPRS	\	Phantom	15	CAB31L0000C1	0.463	0.02
1909.8	810	GPRS	\	Ground	15	CAB31L0000C1	0.516	0.04
1880	661	GPRS	\	Ground	15	CAB31L0000C1	0.544	0.0061
1850.2	512	GPRS	\	Ground	15	CAB31L0000C1	0.525	0.04
1880	661	Speech	CCB316 0A11C1	Ground	15	CAB31L0000C1	0.293	0.03
1880	661	Speech	CCB316 0A11C2	Ground	15	CAB31L0000C1	0.263	0.05

Table 17: SAR Values (WiFi 802.11b - Head)

Frequency		Mode/Band	Side	Test Position	Battery Type	SAR(1g)	Power Drift(dB)
MHz	Ch.					(W/kg)	
2462	11	802.11 b	Left	Touch	CAB31L0000C1	0.190	0.18
2462	11	802.11 b	Left	Tilt	CAB31L0000C1	0.255	-0.10
2462	11	802.11 b	Right	Touch	CAB31L0000C1	0.260	-0.13
2462	11	802.11 b	Right	Tilt	CAB31L0000C1	0.318	-0.19

Table 18: SAR Values (WiFi 802.11b - Body)

Frequency		Mode/Band	Test Position	Spacing (mm)	Battery Type	SAR(1g)	Power Drift(dB)
MHz	Ch.					(W/kg)	
2462	11	802.11 b	Phantom	15	CAB31L0000C1	0.064	0.11
2462	11	802.11 b	Ground	15	CAB31L0000C1	0.107	0.15

15 Measurement Uncertainty

No.	Error Description	Type	Uncertainty value	Probably Distribution	Div.	(Ci) 1g	(Ci) 10g	Std. Unc. (1g)	Std. Unc. (10g)	Degree of freedom
Measurement system										
1	Probe calibration	B	5.5	N	1	1	1	5.5	5.5	∞
2	Isotropy	B	4.7	R	$\sqrt{3}$	0.7	0.7	1.9	1.9	∞
3	Boundary effect	B	1.0	R	$\sqrt{3}$	1	1	0.6	0.6	∞
4	Linearity	B	4.7	R	$\sqrt{3}$	1	1	2.7	2.7	∞
5	Detection limit	B	1.0	N	1	1	1	0.6	0.6	∞
6	Readout electronics	B	0.3	R	$\sqrt{3}$	1	1	0.3	0.3	∞
7	Response time	B	0.8	R	$\sqrt{3}$	1	1	0.5	0.5	∞
8	Integration time	B	2.6	R	$\sqrt{3}$	1	1	1.5	1.5	∞
9	RF ambient conditions-noise	B	0	R	$\sqrt{3}$	1	1	0	0	∞
10	RF ambient conditions-reflection	B	0	R	$\sqrt{3}$	1	1	0	0	∞
11	Probe positioned mech. restrictions	B	0.4	R	$\sqrt{3}$	1	1	0.2	0.2	∞
12	Probe positioning with respect to phantom shell	B	2.9	R	$\sqrt{3}$	1	1	1.7	1.7	∞
13	Post-processing	B	1.0	R	$\sqrt{3}$	1	1	0.6	0.6	∞
Test sample related										
14	Test sample positioning	A	3.3	N	1	1	1	3.3	3.3	71
15	Device holder uncertainty	A	3.4	N	1	1	1	3.4	3.4	5

16	Drift of output power	B	5.0	R	$\sqrt{3}$	1	1	2.9	2.9	∞
Phantom and set-up										
17	Phantom uncertainty	B	4.0	R	$\sqrt{3}$	1	1	2.3	2.3	∞
18	Liquid conductivity (target)	B	5.0	R	$\sqrt{3}$	0.64	0.43	1.8	1.2	∞
19	Liquid conductivity (meas.)	A	2.06	N	1	0.64	0.43	1.32	0.89	43
20	Liquid permittivity (target)	B	5.0	R	$\sqrt{3}$	0.6	0.49	1.7	1.4	∞
No.	Error Description	Type	Uncertainty value	Probably Distribution	Div.	(Ci) 1g	(Ci) 10g	Std. Unc. (1g)	Std. Unc. (10g)	Degree of freedom
21	Liquid permittivity (meas.)	A	1.6	N	1	0.6	0.49	1.0	0.8	521
continue										
Combined standard uncertainty		$u_c = \sqrt{\sum_{i=1}^{21} c_i^2 u_i^2}$						9.25	9.12	257
Expanded uncertainty (confidence interval of 95 %)		$u_e = 2u_c$						18.5	18.2	

16 MAIN TEST INSTRUMENTS

Table 19: List of Main Instruments

No.	Name	Type	Serial Number	Calibration Date	Valid Period
01	Network analyzer	E5071C	MY46110673	Feb 15, 2012	One year
02	Power meter	NRVD	102083	September 11, 2011	One year
03	Power sensor	NRV-Z5	100595		
04	Signal Generator	E4438C	MY49070393	November 12, 2011	One Year
05	Amplifier	VTL5400	0505	No Calibration Requested	
06	BTS	8960	MY48365192	November 17, 2011	One year
07	E-field Probe	SPEAG ES3DV3	3149	September 24, 2011	One year
08	DAE	SPEAG DAE4	771	November 20, 2011	One year
09	Dipole Validation Kit	SPEAG D835V2	443	February 26, 2010	Three years
10	Dipole Validation Kit	SPEAG D1900V2	541	February 26, 2010	Three years
11	Dipole Validation Kit	SPEAG D2450V2	853	September 27, 2010	Three years

END OF REPORT BODY

ANNEX A GRAPH RESULTS

850 Left Cheek High

Date: 2012-2-29

Electronics: DAE4 Sn771

Medium: Head 850 MHz

Medium parameters used (interpolated): $f = 848.8$ MHz; $\sigma = 0.93$ mho/m; $\epsilon_r = 42.1$; $\rho = 1000$ kg/m³

Ambient Temperature: 23.0°C Liquid Temperature: 22.5°C

Communication System: GSM 850 Frequency: 848.8 MHz Duty Cycle: 1:8.3

Probe: ES3DV3 - SN3149 ConvF(6.56, 6.56, 6.56)

Cheek High/Area Scan (61x91x1): Measurement grid: dx=10mm, dy=10mm
Maximum value of SAR (interpolated) = 0.876 mW/g

Cheek High/Zoom Scan (7x7x7)/Cube 0: Measurement grid: dx=5mm, dy=5mm, dz=5mm

Reference Value = 11.424 V/m; Power Drift = 0.05 dB

Peak SAR (extrapolated) = 1.0330

SAR(1 g) = 0.826 mW/g; SAR(10 g) = 0.607 mW/g

Maximum value of SAR (measured) = 0.877 mW/g

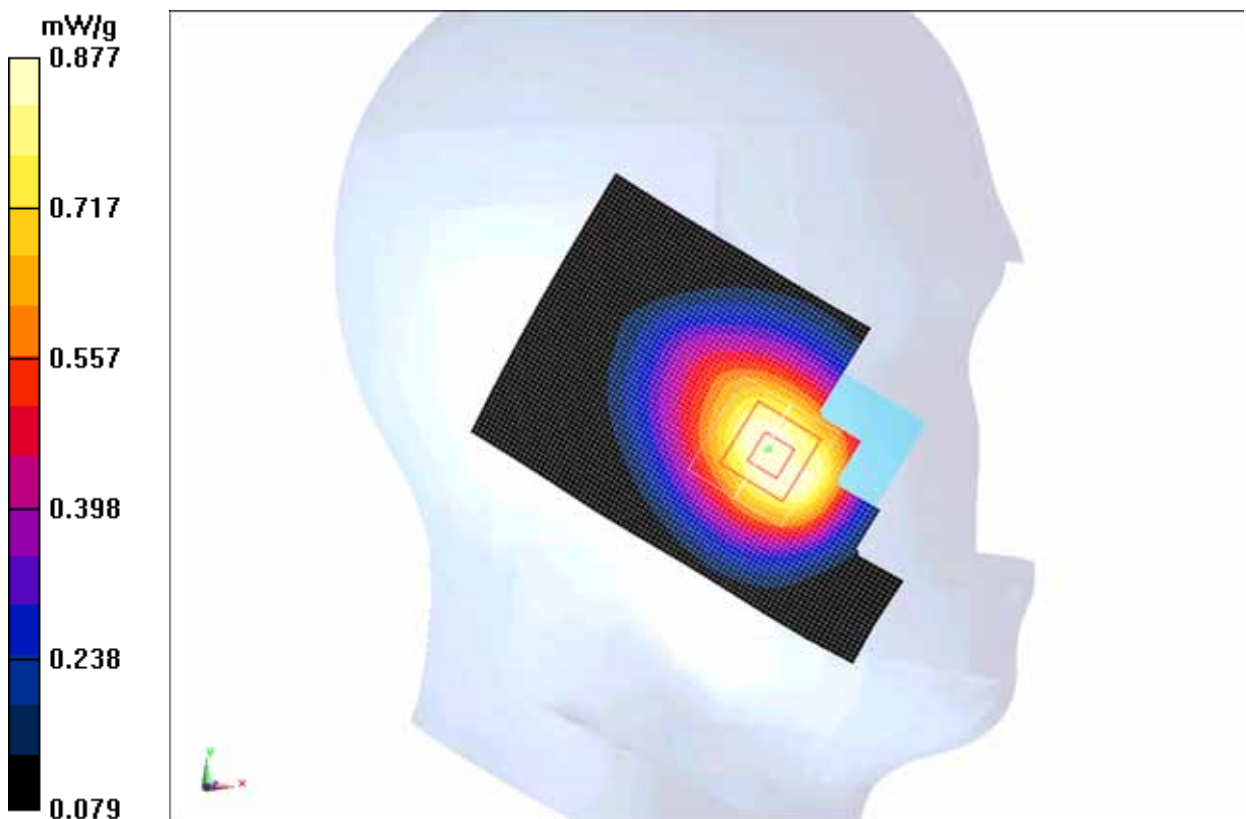

Fig. 1 850MHz CH251

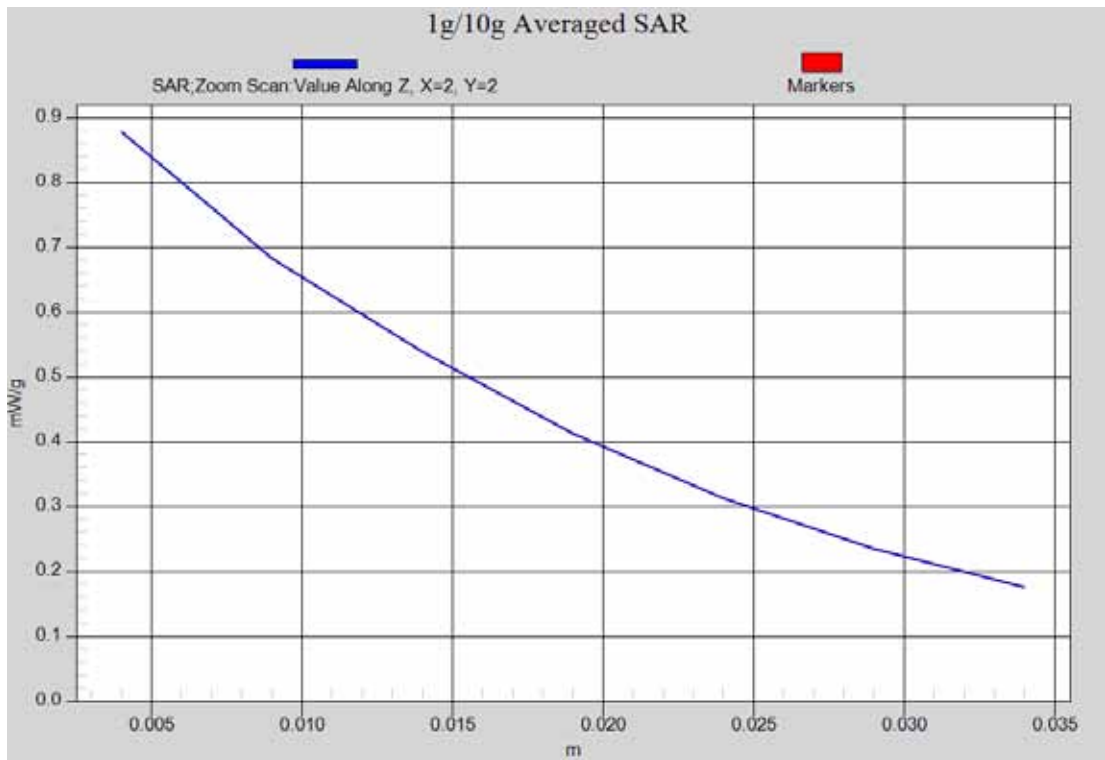

Fig. 1-1 Z-Scan at power reference point (850 MHz CH251)

850 Left Cheek Middle

Date: 2012-2-29

Electronics: DAE4 Sn771

Medium: Head 900

Medium parameters used (interpolated): $f = 836.6$ MHz; $\sigma = 0.92$ mho/m; $\epsilon_r = 42.4$;
 $\rho = 1000$ kg/m³

Ambient Temperature: 23.3°C Liquid Temperature: 22.5°C

Communication System: GSM; Frequency: 836.6 MHz; Duty Cycle: 1:8.3

Probe: ES3DV3 - SN3149 ConvF(6.56, 6.56, 6.56)

Cheek Middle/Area Scan (61x91x1): Measurement grid: dx=10mm, dy=10mm
Maximum value of SAR (interpolated) = 0.722 mW/g

Cheek Middle/Zoom Scan (7x7x7)/Cube 0: Measurement grid: dx=5mm, dy=5mm, dz=5mm

Reference Value = 9.955 V/m; Power Drift = 0.15 dB

Peak SAR (extrapolated) = 0.8520

SAR(1 g) = 0.693 mW/g; SAR(10 g) = 0.518 mW/g

Maximum value of SAR (measured) = 0.729 mW/g

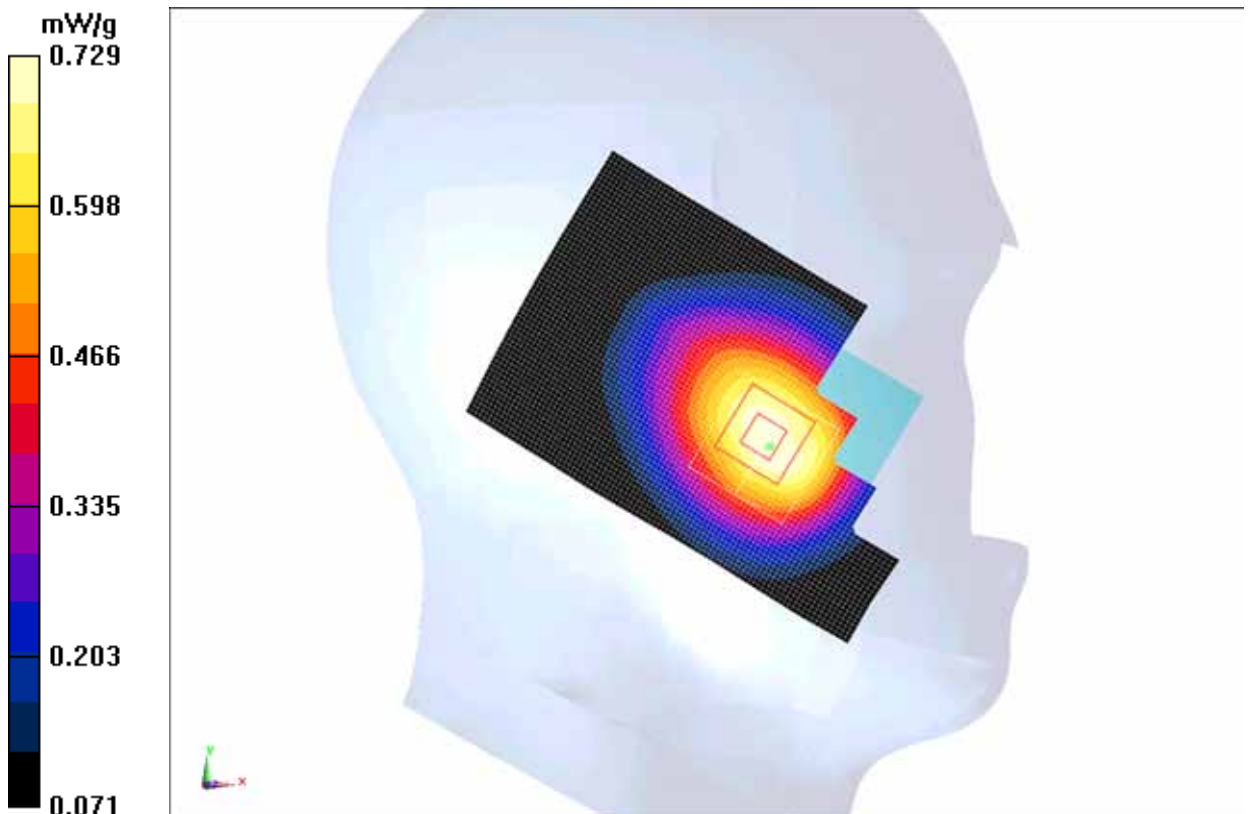

Fig. 2 850 MHz CH190

850 Left Cheek Low

Date: 2012-2-29

Electronics: DAE4 Sn771

Medium: Head 900

Medium parameters used: $f = 825$ MHz; $\sigma = 0.90$ mho/m; $\epsilon_r = 42.7$ $\rho = 1000$ kg/m³

Ambient Temperature: 23.3°C Liquid Temperature: 22.5°C

Communication System: GSM; Frequency: 824.2 MHz; Duty Cycle: 1:8.3

Probe: ES3DV3 - SN3149 ConvF(6.56, 6.56, 6.56)

Cheek Low/Area Scan (61x91x1): Measurement grid: dx=10mm, dy=10mm

Maximum value of SAR (interpolated) = 0.654 mW/g

Cheek Low/Zoom Scan (7x7x7)/Cube 0: Measurement grid: dx=5mm, dy=5mm, dz=5mm

Reference Value = 9.999 V/m; Power Drift = 0.06 dB

Peak SAR (extrapolated) = 0.7650

SAR(1 g) = 0.624 mW/g; SAR(10 g) = 0.469 mW/g

Maximum value of SAR (measured) = 0.649 mW/g

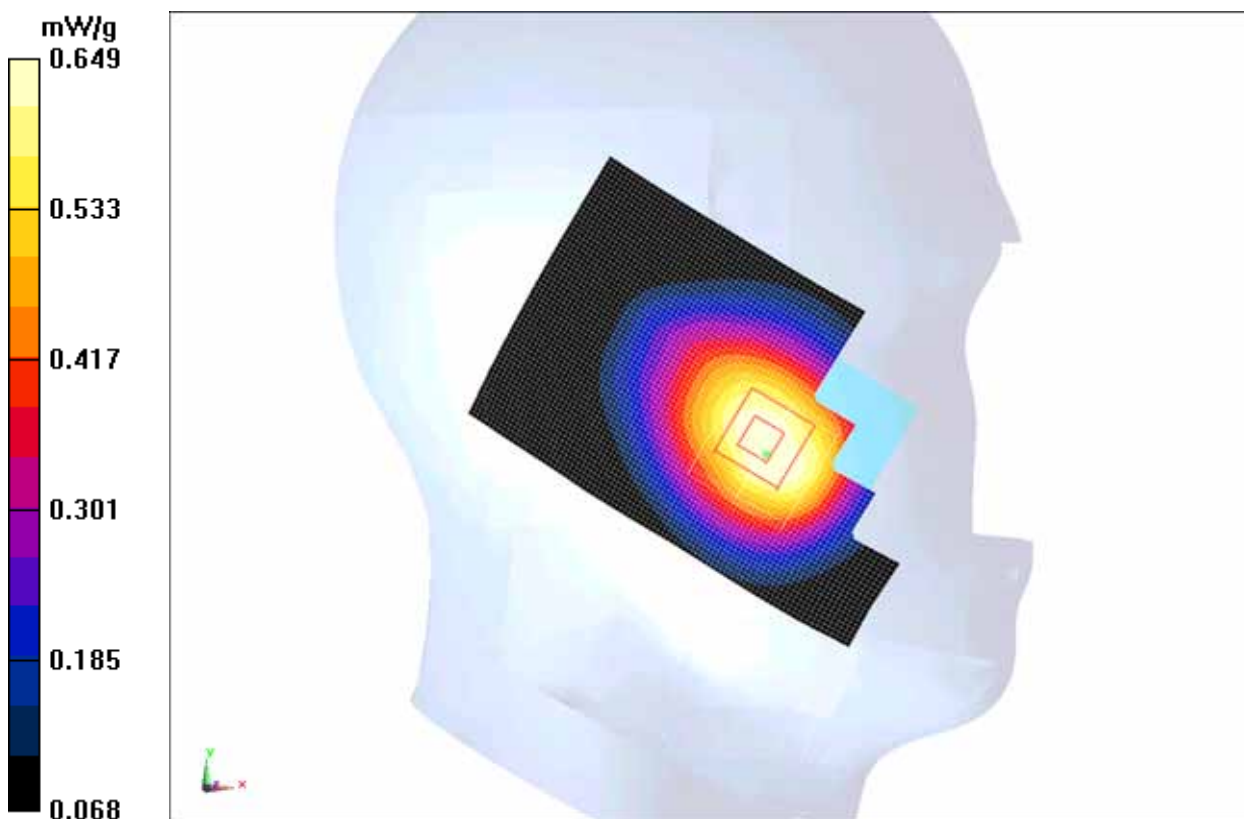

Fig. 3 850 MHz CH128

850 Left Tilt High

Date: 2012-2-29

Electronics: DAE4 Sn771

Medium: Head 850 MHz

Medium parameters used (interpolated): $f = 848.8$ MHz; $\sigma = 0.93$ mho/m; $\epsilon_r = 42.1$;
 $\rho = 1000$ kg/m³

Ambient Temperature: 23.0°C Liquid Temperature: 22.5°C

Communication System: GSM 850 Frequency: 848.8 MHz Duty Cycle: 1:8.3

Probe: ES3DV3 - SN3149 ConvF(6.56, 6.56, 6.56)

Tilt High/Area Scan (61x91x1): Measurement grid: dx=10mm, dy=10mm

Maximum value of SAR (interpolated) = 0.357 mW/g

Tilt High/Zoom Scan (7x7x7)/Cube 0: Measurement grid: dx=5mm, dy=5mm, dz=5mm

Reference Value = 14.179 V/m; Power Drift = -0.02 dB

Peak SAR (extrapolated) = 0.4180

SAR(1 g) = 0.336 mW/g; SAR(10 g) = 0.253 mW/g

Maximum value of SAR (measured) = 0.355 mW/g

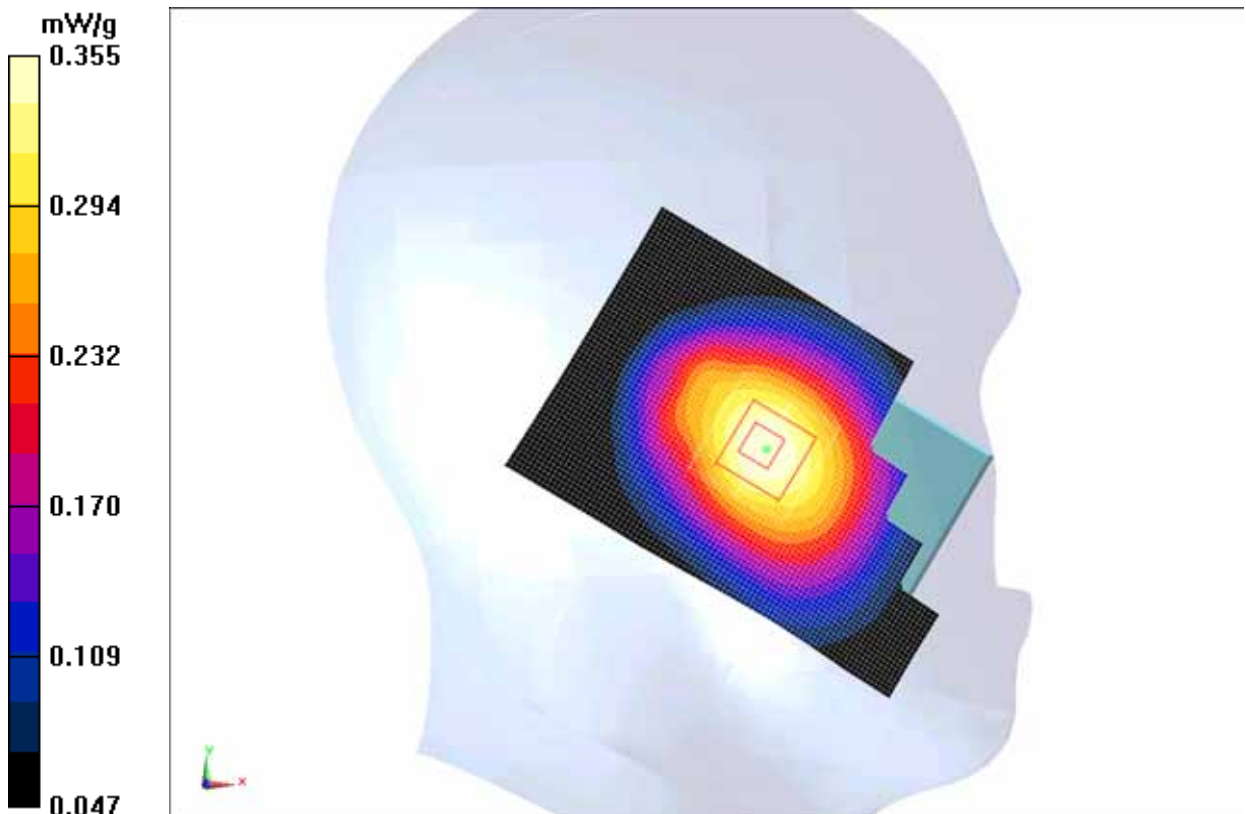

Fig.4 850 MHz CH251

850 Left Tilt Middle

Date: 2012-2-29

Electronics: DAE4 Sn771

Medium: Head 900

Medium parameters used (interpolated): $f = 836.6$ MHz; $\sigma = 0.92$ mho/m; $\epsilon_r = 42.4$; $\rho = 1000$ kg/m³

Ambient Temperature: 23.3°C Liquid Temperature: 22.5°C

Communication System: GSM; Frequency: 836.6 MHz; Duty Cycle: 1:8.30042

Probe: ES3DV3 - SN3149 ConvF(6.56, 6.56, 6.56)

Tilt Middle/Area Scan (61x91x1): Measurement grid: dx=10mm, dy=10mm
Maximum value of SAR (interpolated) = 0.328 mW/g

Tilt Middle/Zoom Scan (7x7x7)/Cube 0: Measurement grid: dx=5mm, dy=5mm, dz=5mm

Reference Value = 13.655 V/m; Power Drift = 0.06 dB

Peak SAR (extrapolated) = 0.3830

SAR(1 g) = 0.309 mW/g; SAR(10 g) = 0.236 mW/g

Maximum value of SAR (measured) = 0.321 mW/g

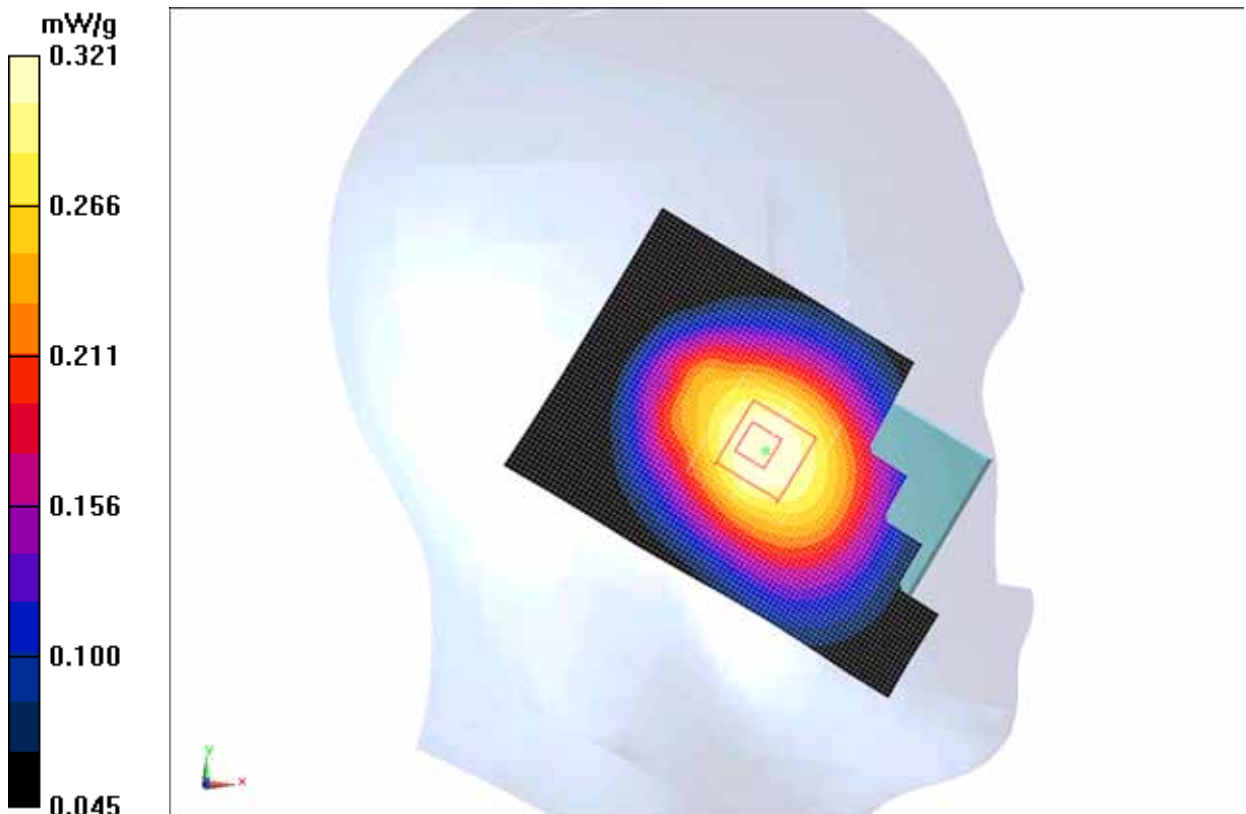

Fig.5 850 MHz CH190

850 Left Tilt Low

Date: 2012-2-29

Electronics: DAE4 Sn771

Medium: Head 850 MHz

Medium parameters used: $f = 825$ MHz; $\sigma = 0.90$ mho/m; $\epsilon_r = 42.7$; $\rho = 1000$ kg/m³

Ambient Temperature: 23.0°C Liquid Temperature: 22.5°C

Communication System: GSM 850 Frequency: 824.2 MHz Duty Cycle: 1:8.3

Probe: ES3DV3 - SN3149 ConvF(6.56, 6.56, 6.56)

Tilt Low/Area Scan (61x91x1): Measurement grid: dx=10mm, dy=10mm

Maximum value of SAR (interpolated) = 0.298 mW/g

Tilt Low/Zoom Scan (7x7x7)/Cube 0: Measurement grid: dx=5mm, dy=5mm, dz=5mm

Reference Value = 13.192 V/m; Power Drift = -0.04 dB

Peak SAR (extrapolated) = 0.3470

SAR(1 g) = 0.280 mW/g; SAR(10 g) = 0.213 mW/g

Maximum value of SAR (measured) = 0.293 mW/g

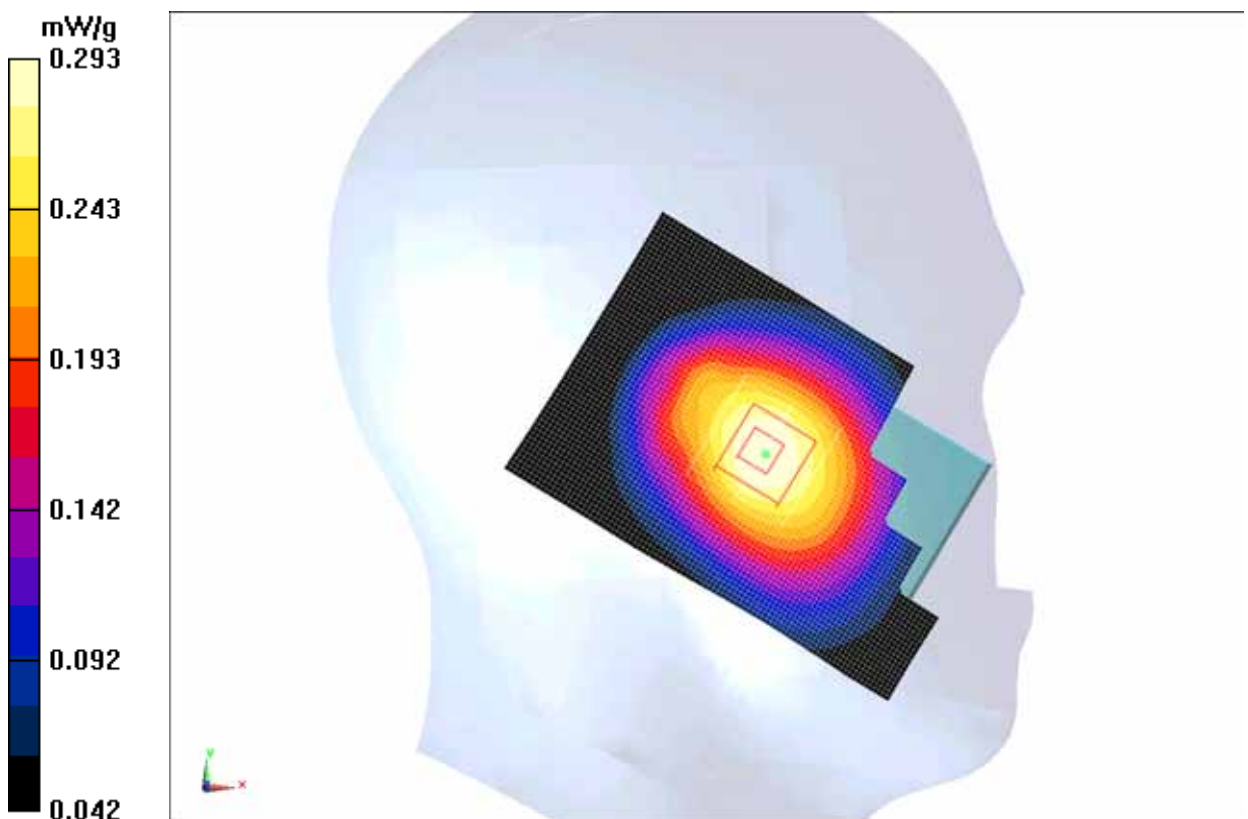

Fig. 6 850 MHz CH128

850 Right Cheek High

Date: 2012-2-29

Electronics: DAE4 Sn771

Medium: Head 900

Medium parameters used (interpolated): $f = 848.8$ MHz; $\sigma = 0.93$ mho/m; $\epsilon_r = 42.1$; $\rho = 1000$ kg/m³

Ambient Temperature: 23.3°C Liquid Temperature: 22.5°C

Communication System: GSM; Frequency: 848.8 MHz; Duty Cycle: 1:8.30042

Probe: ES3DV3 - SN3149 ConvF(6.56, 6.56, 6.56)

Cheek High/Area Scan (61x91x1): Measurement grid: dx=10mm, dy=10mm

Maximum value of SAR (interpolated) = 0.814 mW/g

Cheek High/Zoom Scan (7x7x7)/Cube 0: Measurement grid: dx=5mm, dy=5mm, dz=5mm

Reference Value = 9.978 V/m; Power Drift = 0.04 dB

Peak SAR (extrapolated) = 0.9790

SAR(1 g) = 0.763 mW/g; SAR(10 g) = 0.565 mW/g

Maximum value of SAR (measured) = 0.814 mW/g

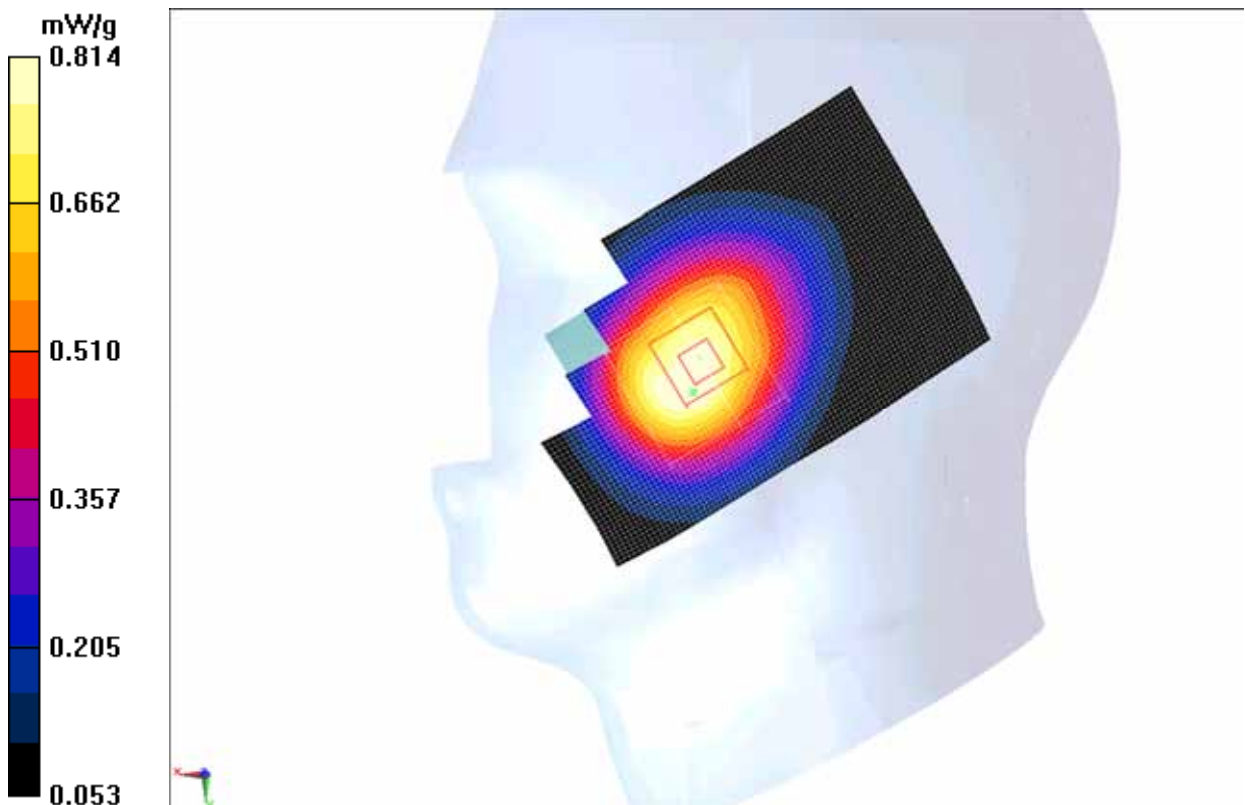

Fig. 7 850 MHz CH251

850 Right Cheek Middle

Date: 2012-2-29

Electronics: DAE4 Sn771

Medium: Head 900

Medium parameters used (interpolated): $f = 836.6$ MHz; $\sigma = 0.92$ mho/m; $\epsilon_r = 42.4$;
 $\rho = 1000$ kg/m³

Ambient Temperature: 23.3°C Liquid Temperature: 22.5°C

Communication System: GSM; Frequency: 836.6 MHz; Duty Cycle: 1:8.30042

Probe: ES3DV3 - SN3149 ConvF(6.56, 6.56, 6.56)

Cheek Middle/Area Scan (61x91x1): Measurement grid: dx=10mm, dy=10mm
Maximum value of SAR (interpolated) = 0.736 mW/g

Cheek Middle/Zoom Scan (7x7x7)/Cube 0: Measurement grid: dx=5mm, dy=5mm, dz=5mm

Reference Value = 9.848 V/m; Power Drift = 0.04 dB

Peak SAR (extrapolated) = 0.8860

SAR(1 g) = 0.691 mW/g; SAR(10 g) = 0.512 mW/g

Maximum value of SAR (measured) = 0.733 mW/g

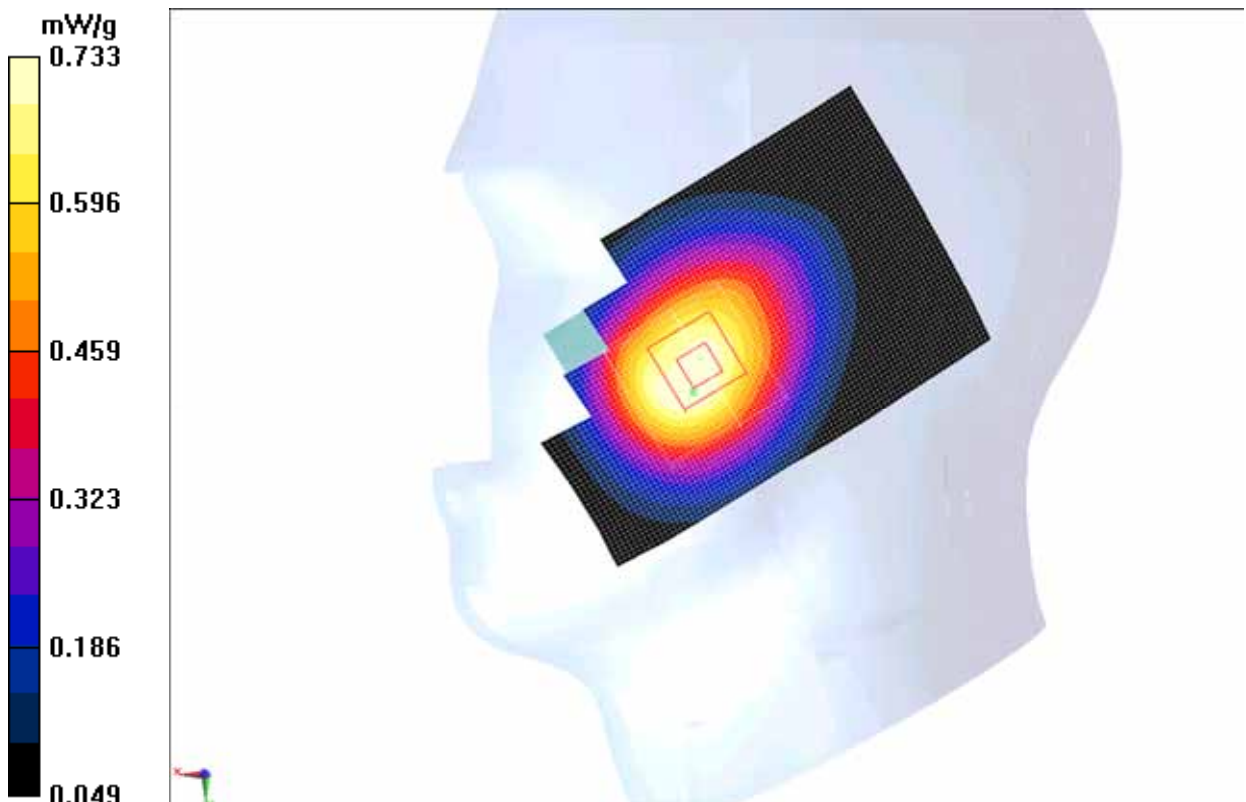

Fig. 8 850 MHz CH190

850 Right Cheek Low

Date: 2012-2-29

Electronics: DAE4 Sn771

Medium: Head 900

Medium parameters used: $f = 825$ MHz; $\sigma = 0.90$ mho/m; $\epsilon_r = 42.7$ $\rho = 1000$ kg/m³

Ambient Temperature: 23.3°C Liquid Temperature: 22.5°C

Communication System: GSM; Frequency: 824.2 MHz; Duty Cycle: 1:8.30042

Probe: ES3DV3 - SN3149 ConvF(6.56, 6.56, 6.56)

Cheek Low/Area Scan (61x91x1): Measurement grid: dx=10mm, dy=10mm

Maximum value of SAR (interpolated) = 0.630 mW/g

Cheek Low/Zoom Scan (7x7x7)/Cube 0: Measurement grid: dx=5mm, dy=5mm, dz=5mm

Reference Value = 9.317 V/m; Power Drift = -0.0077 dB

Peak SAR (extrapolated) = 0.7580

SAR(1 g) = 0.581 mW/g; SAR(10 g) = 0.434 mW/g

Maximum value of SAR (measured) = 0.614 mW/g

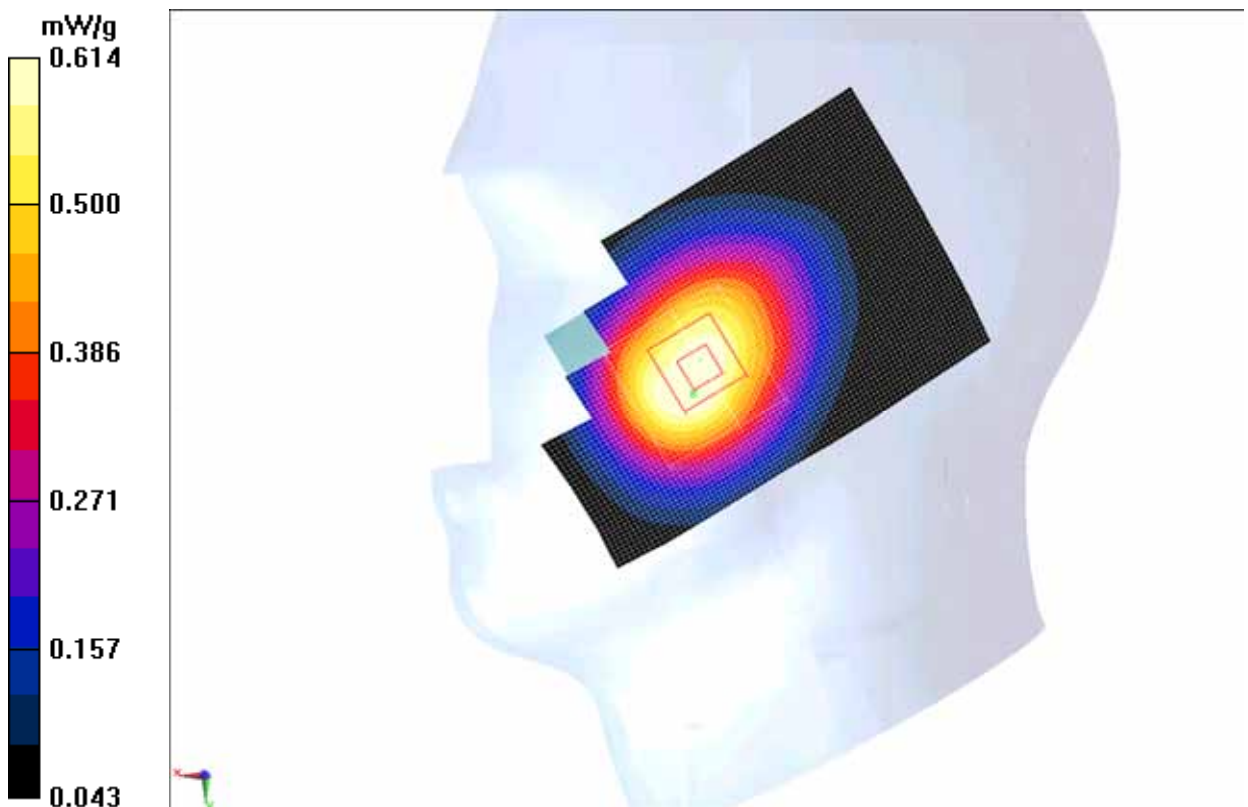

Fig. 9 850 MHz CH128

850 Right Tilt High

Date: 2012-2-29

Electronics: DAE4 Sn771

Medium: Head 850 MHz

Medium parameters used (interpolated): $f = 848.8$ MHz; $\sigma = 0.93$ mho/m; $\epsilon_r = 42.1$;
 $\rho = 1000$ kg/m³

Ambient Temperature: 23.0°C Liquid Temperature: 22.5°C

Communication System: GSM 850 Frequency: 848.8 MHz Duty Cycle: 1:8.3

Probe: ES3DV3 - SN3149 ConvF(6.56, 6.56, 6.56)

Tilt High/Area Scan (61x91x1): Measurement grid: dx=10mm, dy=10mm
Maximum value of SAR (interpolated) = 0.407 mW/g

Tilt High/Zoom Scan (7x7x7)/Cube 0: Measurement grid: dx=5mm, dy=5mm,
dz=5mm

Reference Value = 15.483 V/m; Power Drift = -0.10 dB

Peak SAR (extrapolated) = 0.4760

SAR(1 g) = 0.383 mW/g; SAR(10 g) = 0.289 mW/g

Maximum value of SAR (measured) = 0.400 mW/g

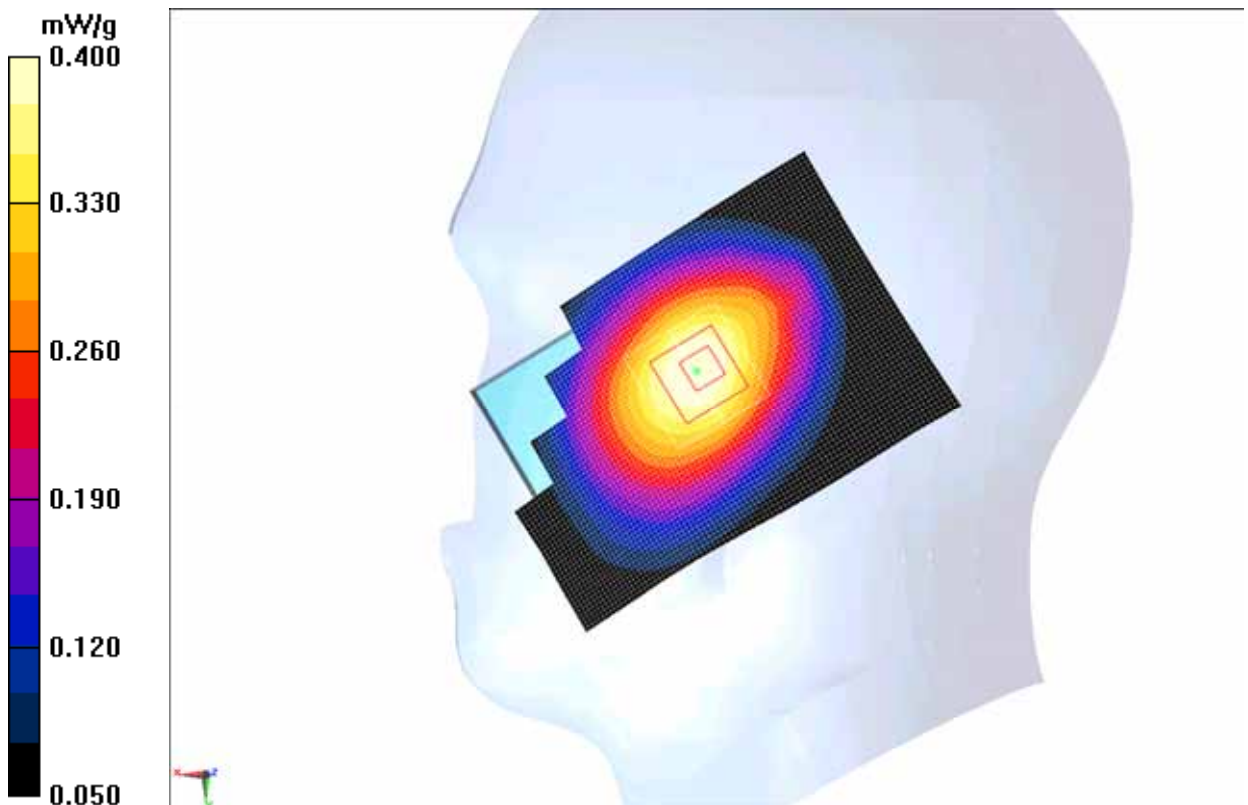

Fig.10 850 MHz CH251

850 Right Tilt Middle

Date: 2012-2-29

Electronics: DAE4 Sn771

Medium: Head 850 MHz

Medium parameters used (interpolated): $f = 836.6$ MHz; $\sigma = 0.92$ mho/m; $\epsilon_r = 42.4$;
 $\rho = 1000$ kg/m³

Ambient Temperature: 23.0°C Liquid Temperature: 22.5°C

Communication System: GSM 850 Frequency: 836.6 MHz Duty Cycle: 1:8.3

Probe: ES3DV3 - SN3149 ConvF(6.56, 6.56, 6.56)

Tilt Middle/Area Scan (61x91x1): Measurement grid: dx=10mm, dy=10mm
Maximum value of SAR (interpolated) = 0.368 mW/g

Tilt Middle/Zoom Scan (7x7x7)/Cube 0: Measurement grid: dx=5mm, dy=5mm,
dz=5mm

Reference Value = 14.726 V/m; Power Drift = -0.0056 dB

Peak SAR (extrapolated) = 0.4270

SAR(1 g) = 0.345 mW/g; SAR(10 g) = 0.262 mW/g

Maximum value of SAR (measured) = 0.360 mW/g

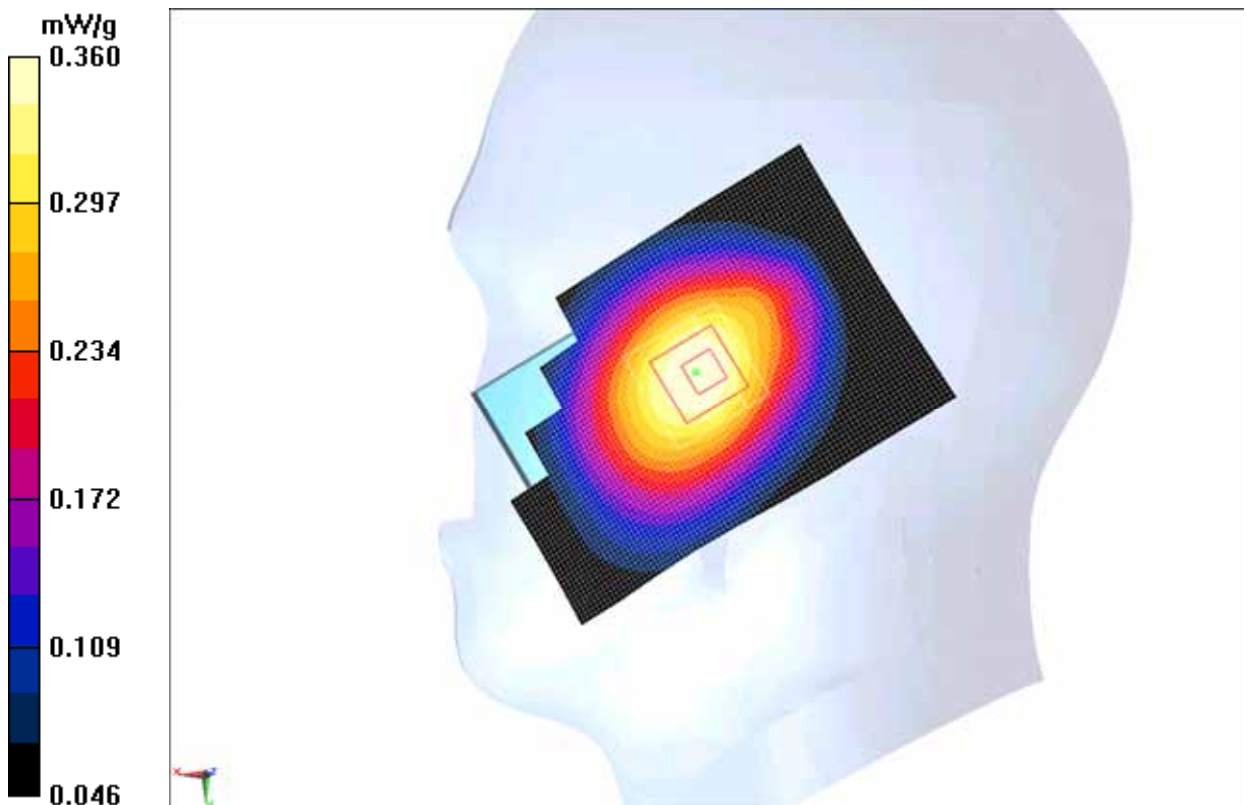

Fig.11 850 MHz CH190

850 Right Tilt Low

Date: 2012-2-14

Electronics: DAE4 Sn771

Medium: Head 850 MHz

Medium parameters used: $f = 825$ MHz; $\sigma = 0.90$ mho/m; $\epsilon_r = 42.7$; $\rho = 1000$ kg/m³

Ambient Temperature: 23.0°C Liquid Temperature: 22.5°C

Communication System: GSM 850 Frequency: 824.2 MHz Duty Cycle: 1:8.3

Probe: ES3DV3 - SN3149 ConvF(6.56, 6.56, 6.56)

Tilt Low/Area Scan (61x91x1): Measurement grid: dx=10mm, dy=10mm

Maximum value of SAR (interpolated) = 0.308 mW/g

Tilt Low/Zoom Scan (7x7x7)/Cube 0: Measurement grid: dx=5mm, dy=5mm, dz=5mm

Reference Value = 13.582 V/m; Power Drift = -0.10 dB

Peak SAR (extrapolated) = 0.3490

SAR(1 g) = 0.286 mW/g; SAR(10 g) = 0.218 mW/g

Maximum value of SAR (measured) = 0.297 mW/g

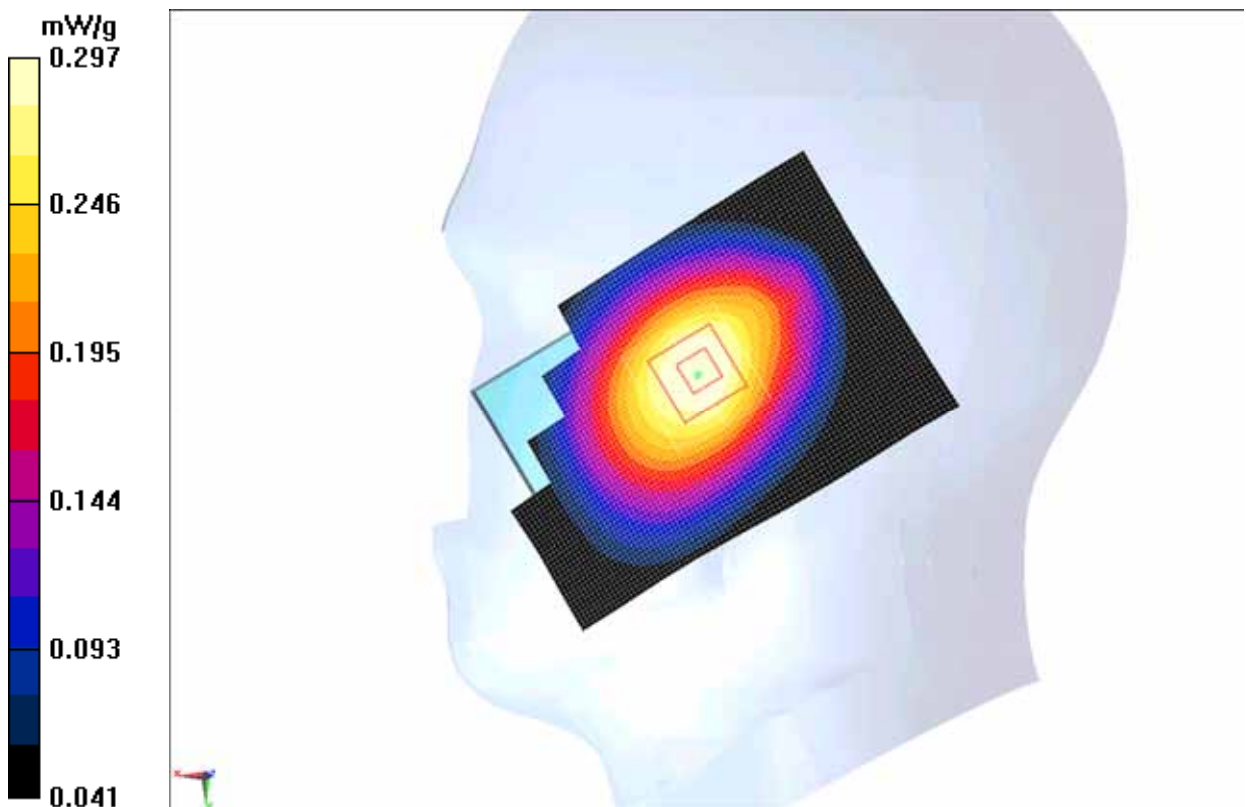

Fig. 12 850 MHz CH128

850 Body Towards Phantom High

Date: 2012-2-29

Electronics: DAE4 Sn771

Medium: 900 Body

Medium parameters used (interpolated): $f = 848.8$ MHz; $\sigma = 0.99$ mho/m; $\epsilon_r = 53.1$;
 $\rho = 1000$ kg/m³

Ambient Temperature: 23.3°C Liquid Temperature: 22.5°C

Communication System: GSM 850 GPRS Frequency: 848.8 MHz Duty Cycle: 1:2

Probe: ES3DV3 - SN3149 ConvF(6.22, 6.22, 6.22)

Toward Phantom High/Area Scan (61x101x1): Measurement grid: dx=10mm, dy=10mm

Maximum value of SAR (interpolated) = 1.062 mW/g

Toward Phantom High/Zoom Scan (7x7x7)/Cube 0: Measurement grid: dx=5mm, dy=5mm, dz=5mm

Reference Value = 30.302 V/m; Power Drift = -0.19 dB

Peak SAR (extrapolated) = 1.2730

SAR(1 g) = 0.991 mW/g; SAR(10 g) = 0.728 mW/g

Maximum value of SAR (measured) = 1.043 mW/g

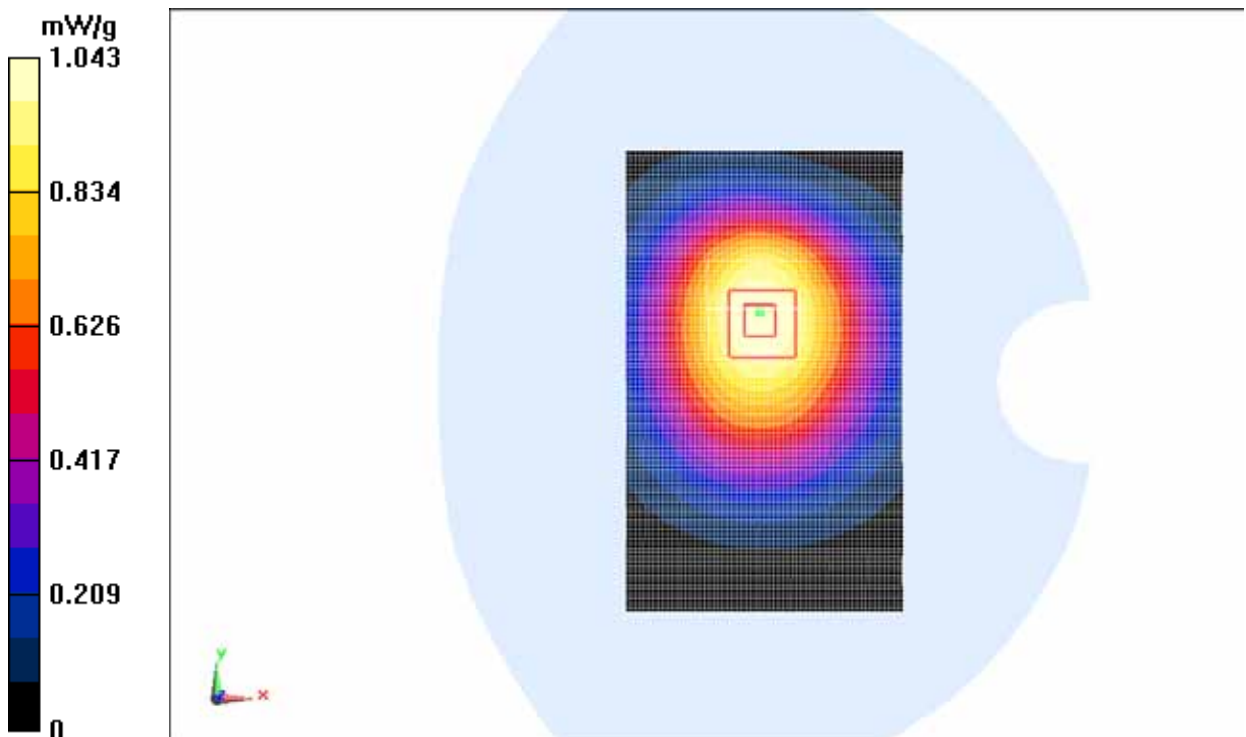

Fig. 13 850 MHz CH251

850 Body Towards Phantom Middle

Date: 2012-2-29

Electronics: DAE4 Sn771

Medium: 900 Body

Medium parameters used (interpolated): $f = 836.6$ MHz; $\sigma = 0.97$ mho/m; $\epsilon_r = 53.6$;
 $\rho = 1000$ kg/m³

Ambient Temperature: 23.3°C Liquid Temperature: 22.5°C

Communication System: GSM 850 GPRS Frequency: 836.6 MHz Duty Cycle: 1:2

Probe: ES3DV3 - SN3149 ConvF(6.22, 6.22, 6.22)

Toward Phantom Middle/Area Scan (61x101x1): Measurement grid: dx=10mm, dy=10mm

Maximum value of SAR (interpolated) = 0.979 mW/g

Toward Phantom Middle/Zoom Scan (7x7x7)/Cube 0: Measurement grid: dx=5mm, dy=5mm, dz=5mm

Reference Value = 28.562 V/m; Power Drift = -0.01 dB

Peak SAR (extrapolated) = 1.1670

SAR(1 g) = 0.919 mW/g; SAR(10 g) = 0.678 mW/g

Maximum value of SAR (measured) = 0.965 mW/g

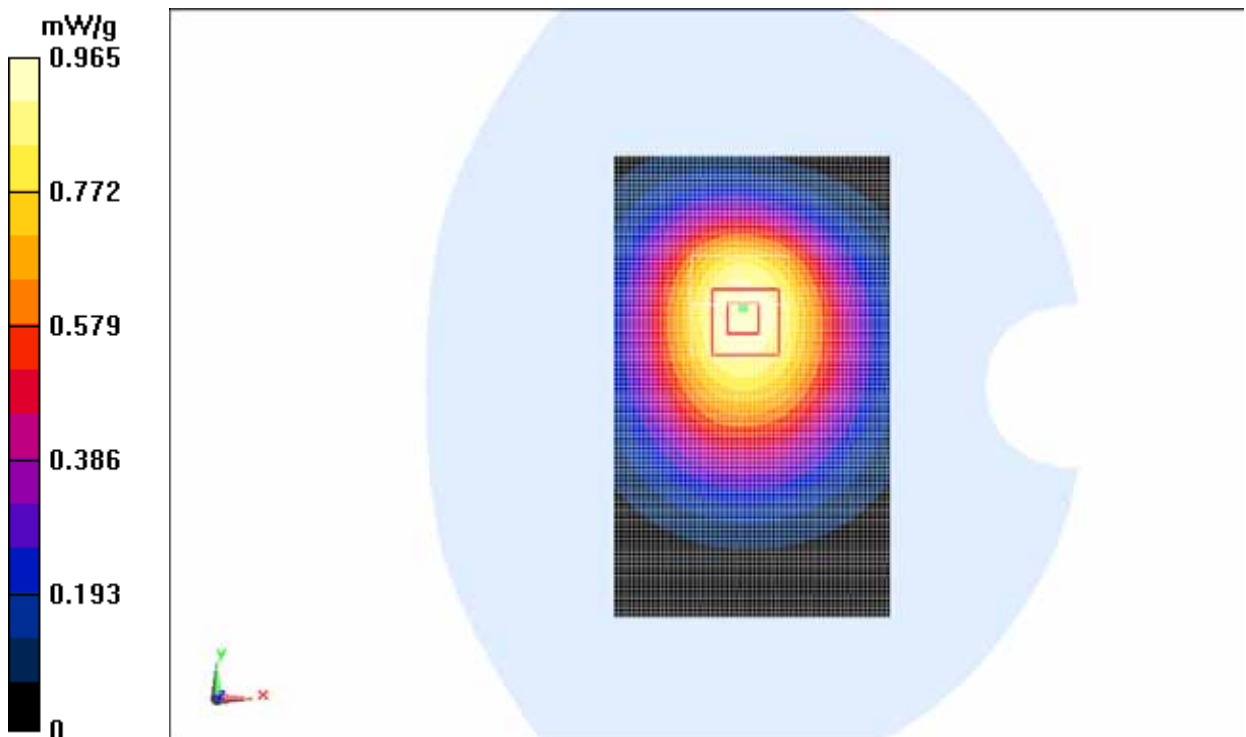

Fig. 14 850 MHz CH190

850 Body Towards Phantom Low

Date: 2012-2-29

Electronics: DAE4 Sn771

Medium: 900 Body

Medium parameters used: $f = 825$ MHz; $\sigma = 0.96$ mho/m; $\epsilon_r = 53.9$; $\rho = 1000$ kg/m³

Ambient Temperature: 23.3°C Liquid Temperature: 22.5°C

Communication System: GSM 850 GPRS Frequency: 824.2 MHz Duty Cycle: 1:2

Probe: ES3DV3 - SN3149 ConvF(6.22, 6.22, 6.22)

Toward Phantom Low/Area Scan (61x101x1): Measurement grid: dx=10mm, dy=10mm

Maximum value of SAR (interpolated) = 0.916 mW/g

Toward Phantom Low/Zoom Scan (7x7x7)/Cube 0: Measurement grid: dx=5mm, dy=5mm, dz=5mm

Reference Value = 27.592 V/m; Power Drift = -0.03 dB

Peak SAR (extrapolated) = 1.0830

SAR(1 g) = 0.863 mW/g; SAR(10 g) = 0.638 mW/g

Maximum value of SAR (measured) = 0.905 mW/g

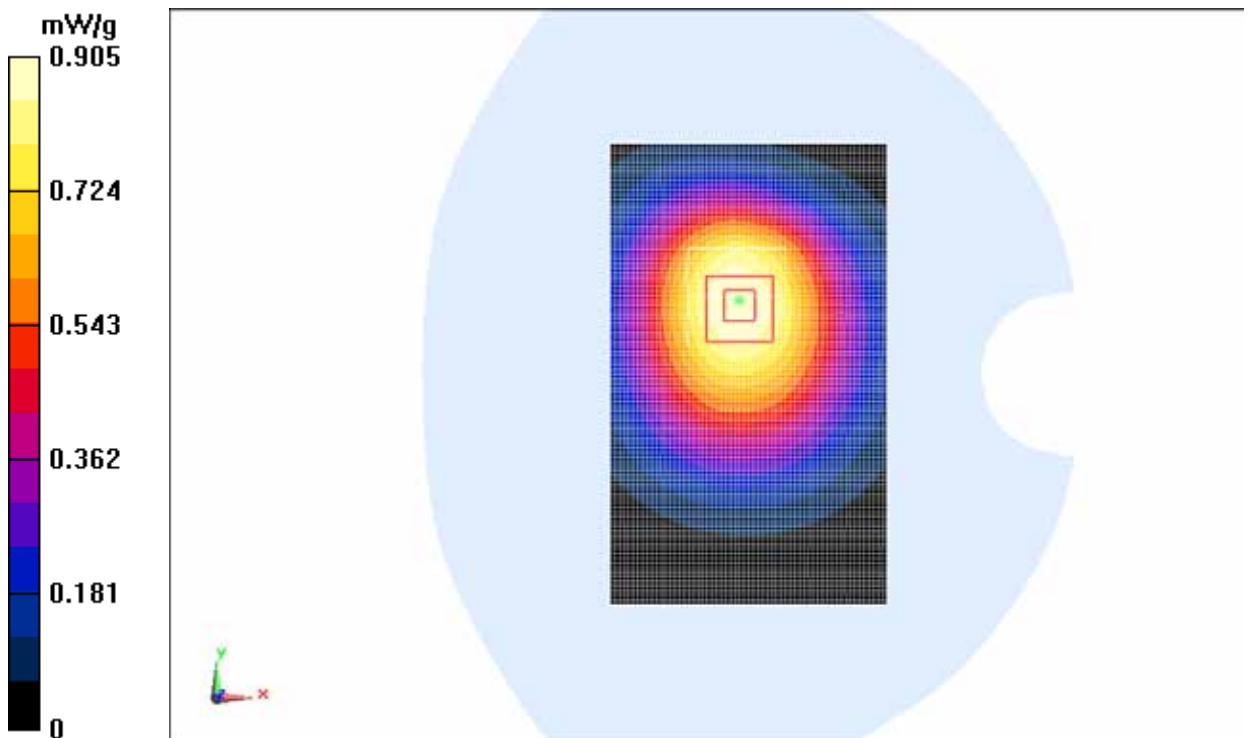

Fig. 15 850 MHz CH128

850 Body Towards Ground High

Date: 2012-2-29

Electronics: DAE4 Sn771

Medium: 900 Body

Medium parameters used (interpolated): $f = 848.8$ MHz; $\sigma = 0.99$ mho/m; $\epsilon_r = 53.1$;
 $\rho = 1000$ kg/m³

Ambient Temperature: 23.3°C Liquid Temperature: 22.5°C

Communication System: GSM 850 GPRS Frequency: 848.8 MHz Duty Cycle: 1:2

Probe: ES3DV3 - SN3149 ConvF(6.22, 6.22, 6.22)

Toward Ground High/Area Scan (61x101x1): Measurement grid: dx=10mm, dy=10mm

Maximum value of SAR (interpolated) = 1.116 mW/g

Toward Ground High/Zoom Scan (7x7x7)/Cube 0: Measurement grid: dx=5mm, dy=5mm, dz=5mm

Reference Value = 30.082 V/m; Power Drift = -0.12 dB

Peak SAR (extrapolated) = 1.3840

SAR(1 g) = 1.05 mW/g; SAR(10 g) = 0.755 mW/g

Maximum value of SAR (measured) = 1.115 mW/g

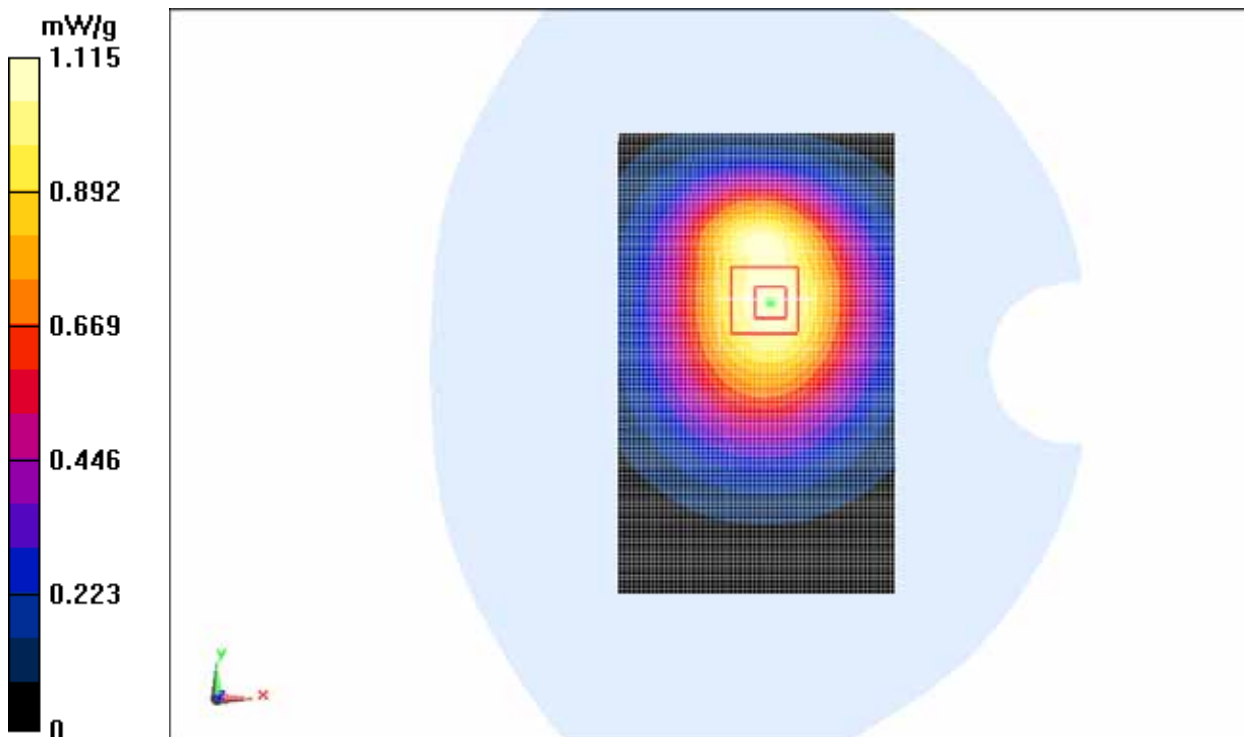

Fig. 16 850 MHz CH251

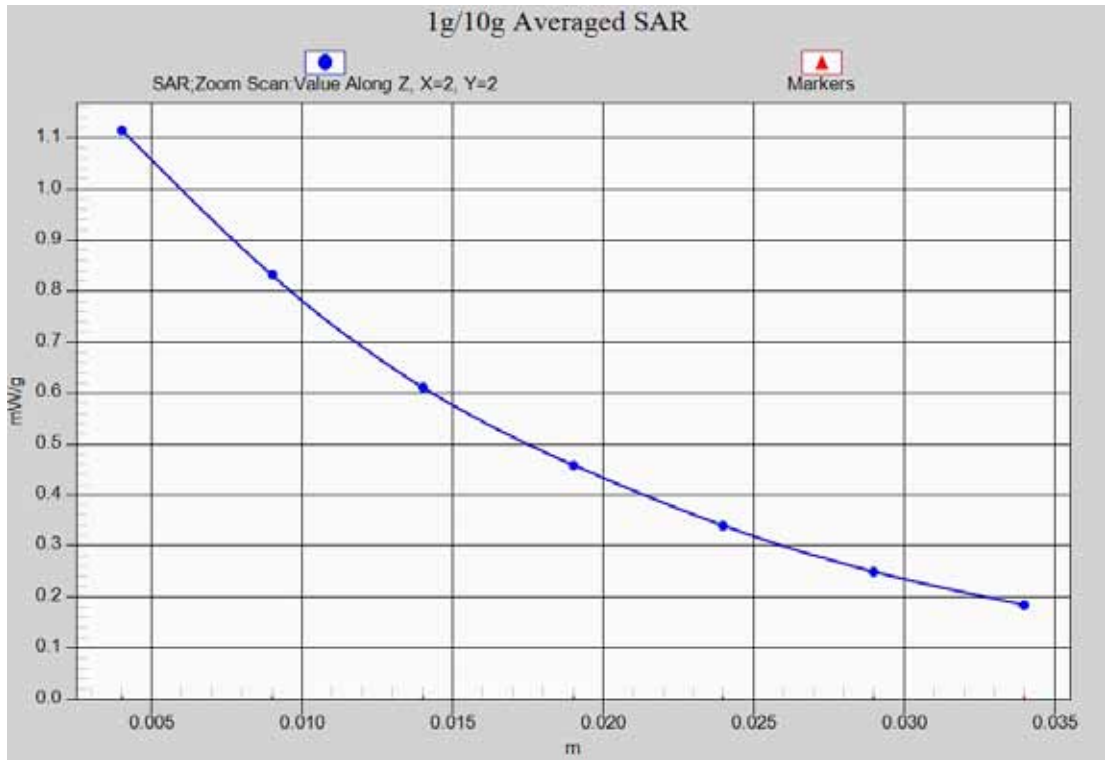

Fig. 16-1 Z-Scan at power reference point (850 MHz CH251)

850 Body Towards Ground Middle

Date: 2012-2-29

Electronics: DAE4 Sn771

Medium: 900 Body

Medium parameters used (interpolated): $f = 836.6$ MHz; $\sigma = 0.97$ mho/m; $\epsilon_r = 53.6$;
 $\rho = 1000$ kg/m³

Ambient Temperature: 23.3°C Liquid Temperature: 22.5°C

Communication System: GSM 850 GPRS Frequency: 836.6 MHz Duty Cycle: 1:2

Probe: ES3DV3 - SN3149 ConvF(6.22, 6.22, 6.22)

Toward Ground Middle/Area Scan (61x101x1): Measurement grid: dx=10mm, dy=10mm

Maximum value of SAR (interpolated) = 1.058 mW/g

Toward Ground Middle/Zoom Scan (7x7x7)/Cube 0: Measurement grid: dx=5mm, dy=5mm, dz=5mm

Reference Value = 29.394 V/m; Power Drift = 0.0085 dB

Peak SAR (extrapolated) = 1.3150

SAR(1 g) = 1 mW/g; SAR(10 g) = 0.724 mW/g

Maximum value of SAR (measured) = 1.066 mW/g

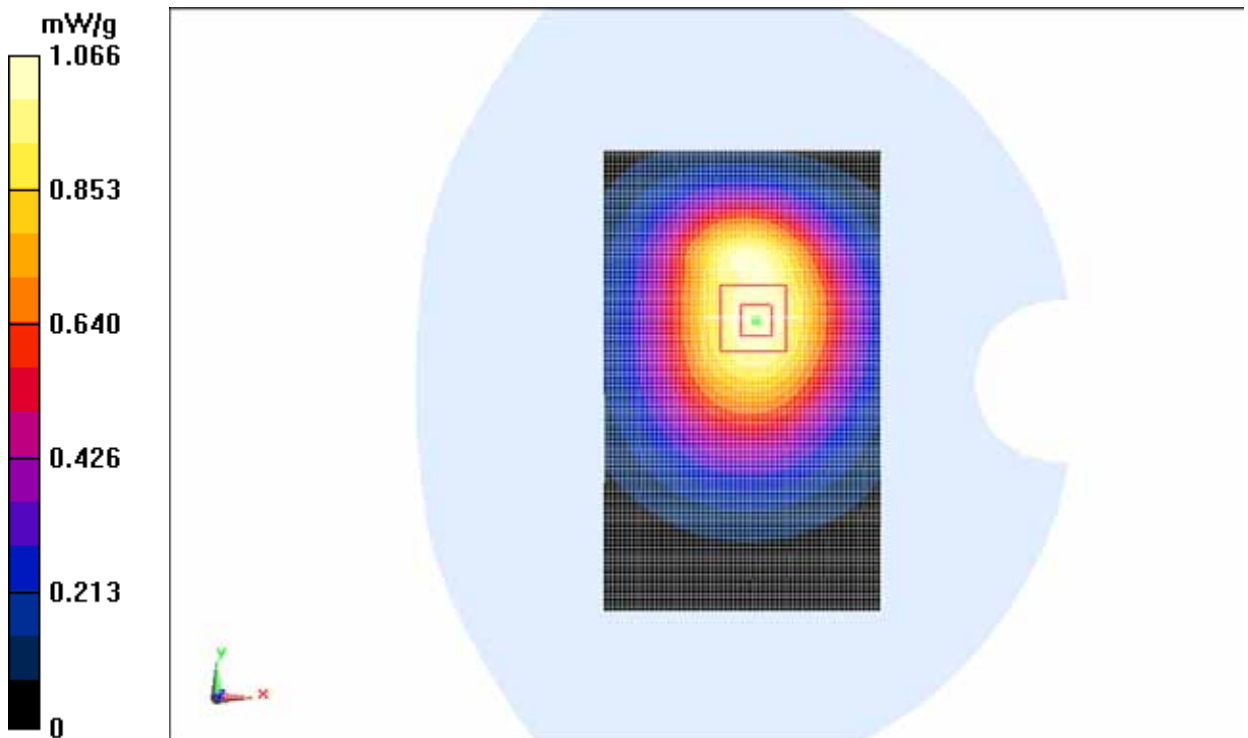

Fig. 17 850 MHz CH190

850 Body Towards Ground Low

Date: 2012-2-29

Electronics: DAE4 Sn771

Medium: 900 Body

Medium parameters used: $f = 825 \text{ MHz}$; $\sigma = 0.96 \text{ mho/m}$; $\epsilon_r = 53.9$; $\rho = 1000 \text{ kg/m}^3$

Ambient Temperature: 23.3°C Liquid Temperature: 22.5°C

Communication System: GSM 850 GPRS Frequency: 824.2 MHz Duty Cycle: 1:2

Probe: ES3DV3 - SN3149 ConvF(6.22, 6.22, 6.22)

Toward Ground Low/Area Scan (61x101x1): Measurement grid: $dx=10\text{mm}$, $dy=10\text{mm}$

Maximum value of SAR (interpolated) = 1.009 mW/g

Toward Ground Low/Zoom Scan (7x7x7)/Cube 0: Measurement grid: $dx=5\text{mm}$, $dy=5\text{mm}$, $dz=5\text{mm}$

Reference Value = 28.495 V/m ; Power Drift = 0.06 dB

Peak SAR (extrapolated) = 1.2660

SAR(1 g) = 0.958 mW/g ; SAR(10 g) = 0.691 mW/g

Maximum value of SAR (measured) = 1.015 mW/g

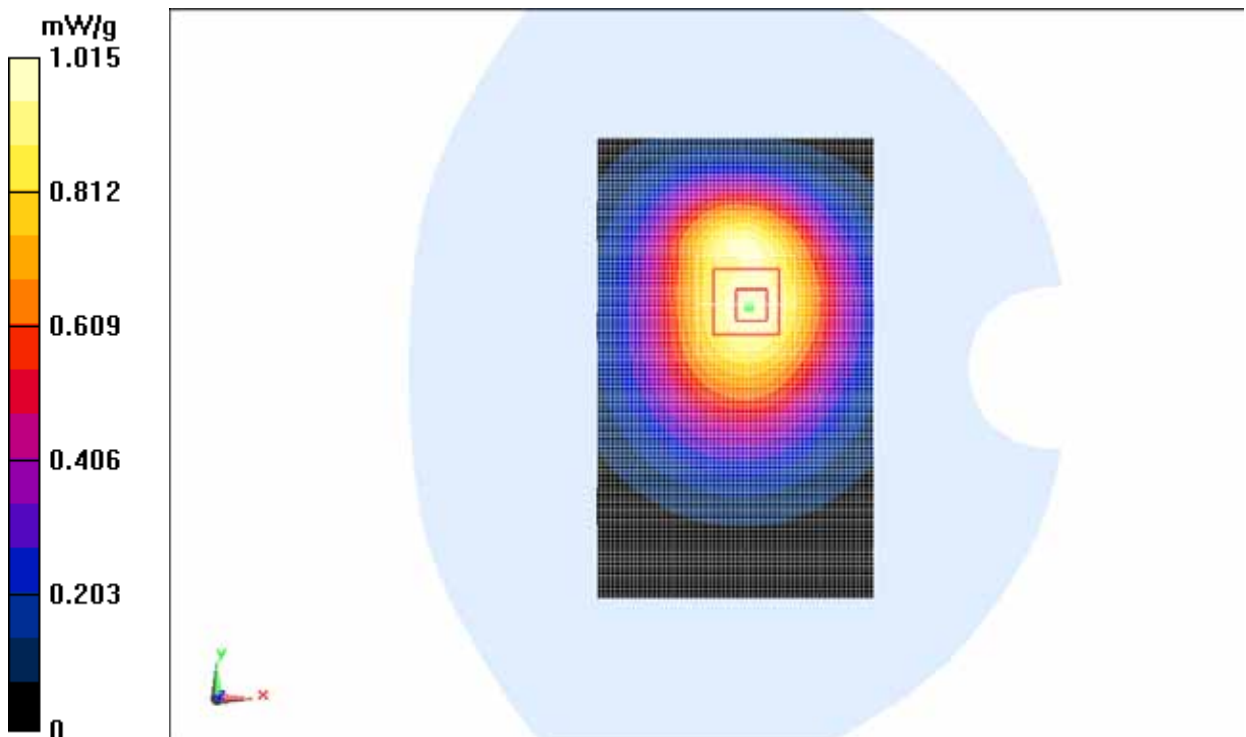

Fig. 18 850 MHz CH128

850 Body Towards Ground High with Headset (CCB3160A11C1)

Date: 2012-2-29

Electronics: DAE4 Sn771

Medium: 900 Body

Medium parameters used (interpolated): $f = 848.8$ MHz; $\sigma = 0.99$ mho/m; $\epsilon_r = 53.1$;
 $\rho = 1000$ kg/m³

Ambient Temperature: 23.3°C Liquid Temperature: 22.5°C

Communication System: GSM 850 Frequency: 848.8 MHz Duty Cycle: 1:8.3

Probe: ES3DV3 - SN3149 ConvF(6.22, 6.22, 6.22)

Toward Ground High/Area Scan (61x101x1): Measurement grid: dx=10mm, dy=10mm

Maximum value of SAR (interpolated) = 0.530 mW/g

Toward Ground High/Zoom Scan (7x7x7)/Cube 0: Measurement grid: dx=5mm, dy=5mm, dz=5mm

Reference Value = 20.943 V/m; Power Drift = 0.04 dB

Peak SAR (extrapolated) = 0.6690

SAR(1 g) = 0.497 mW/g; SAR(10 g) = 0.355 mW/g

Maximum value of SAR (measured) = 0.527 mW/g

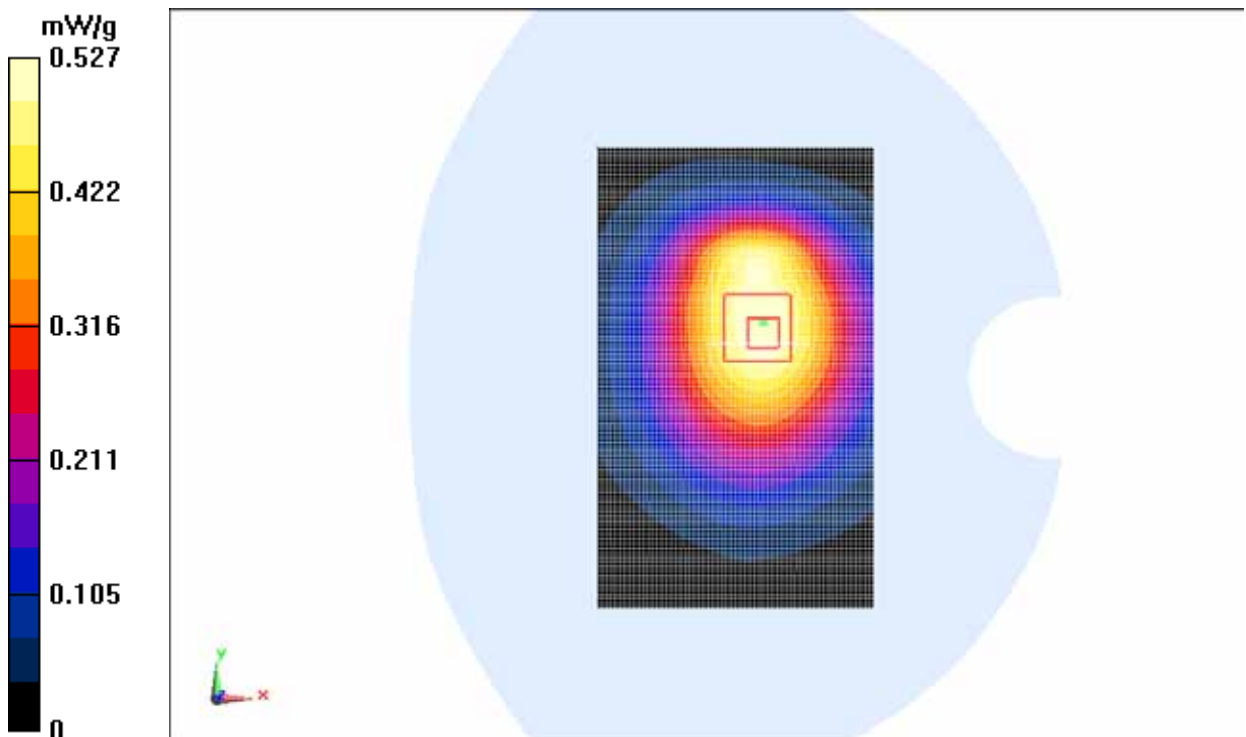

Fig. 19 850 MHz CH251

850 Body Towards Ground High with Headset (CCB3160A11C2)

Date: 2012-2-29

Electronics: DAE4 Sn771

Medium: 900 Body

Medium parameters used (interpolated): $f = 848.8$ MHz; $\sigma = 0.99$ mho/m; $\epsilon_r = 53.1$;
 $\rho = 1000$ kg/m³

Ambient Temperature: 23.3°C Liquid Temperature: 22.5°C

Communication System: GSM 850 Frequency: 848.8 MHz Duty Cycle: 1:8.3

Probe: ES3DV3 - SN3149 ConvF(6.22, 6.22, 6.22)

Toward Ground High/Area Scan (61x101x1): Measurement grid: dx=10mm, dy=10mm

Maximum value of SAR (interpolated) = 0.392 mW/g

Toward Ground High/Zoom Scan (5x6x7)/Cube 0: Measurement grid: dx=5mm, dy=5mm, dz=5mm

Reference Value = 15.900 V/m; Power Drift = 0.04 dB

Peak SAR (extrapolated) = 0.5170

SAR(1 g) = 0.358 mW/g; SAR(10 g) = 0.246 mW/g

Maximum value of SAR (measured) = 0.384 mW/g

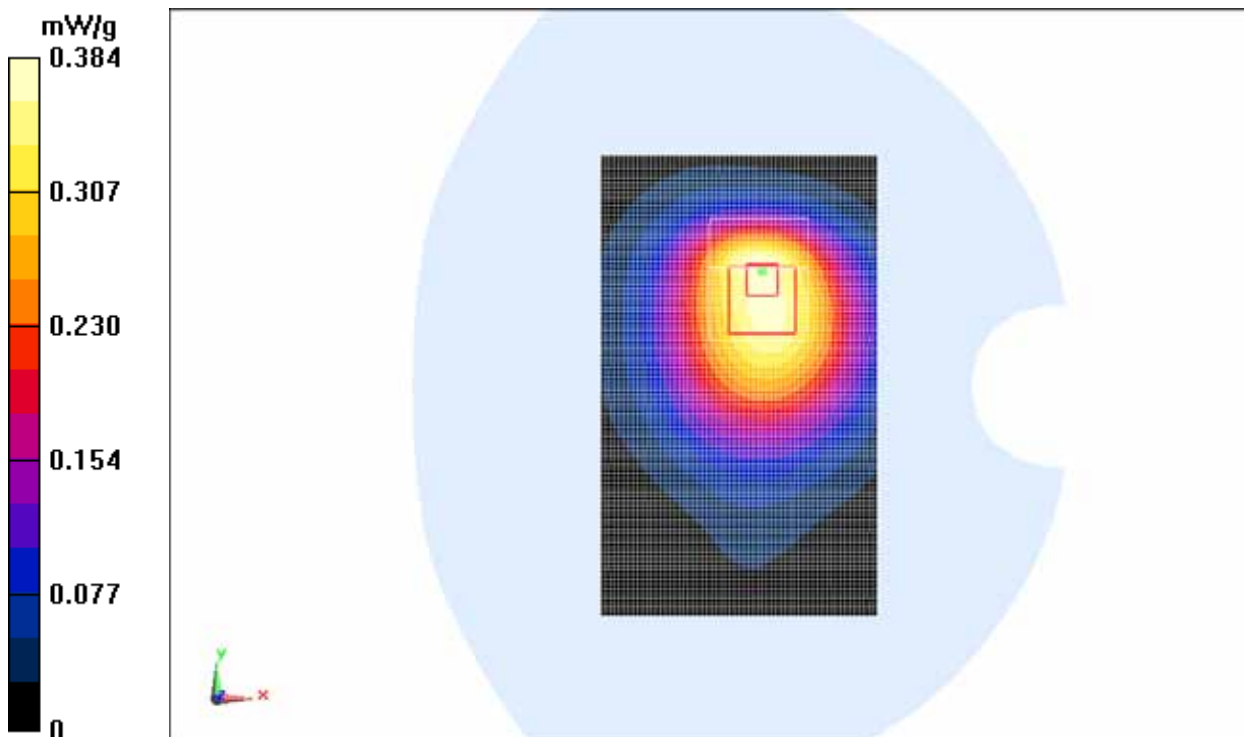

Fig. 20 850 MHz CH251

1900 Left Cheek High

Date: 2012-3-1

Electronics: DAE4 Sn771

Medium: Head 1900 MHz

Medium parameters used: $f = 1910$ MHz; $\sigma = 1.42$ mho/m; $\epsilon_r = 40.2$; $\rho = 1000$ kg/m³

Ambient Temperature: 23.0°C Liquid Temperature: 22.5°C

Communication System: GSM 1900MHz Frequency: 1909.8 MHz Duty Cycle: 1:8.3

Probe: ES3DV3 - SN3149 ConvF(5.03, 5.03, 5.03)

Cheek High/Area Scan (61x91x1): Measurement grid: dx=10mm, dy=10mm

Maximum value of SAR (interpolated) = 0.616 mW/g

Cheek High/Zoom Scan (7x7x7)/Cube 0: Measurement grid: dx=5mm, dy=5mm, dz=5mm

Reference Value = 9.993 V/m; Power Drift = -0.04 dB

Peak SAR (extrapolated) = 0.8880

SAR(1 g) = 0.555 mW/g; SAR(10 g) = 0.314 mW/g

Maximum value of SAR (measured) = 0.621 mW/g

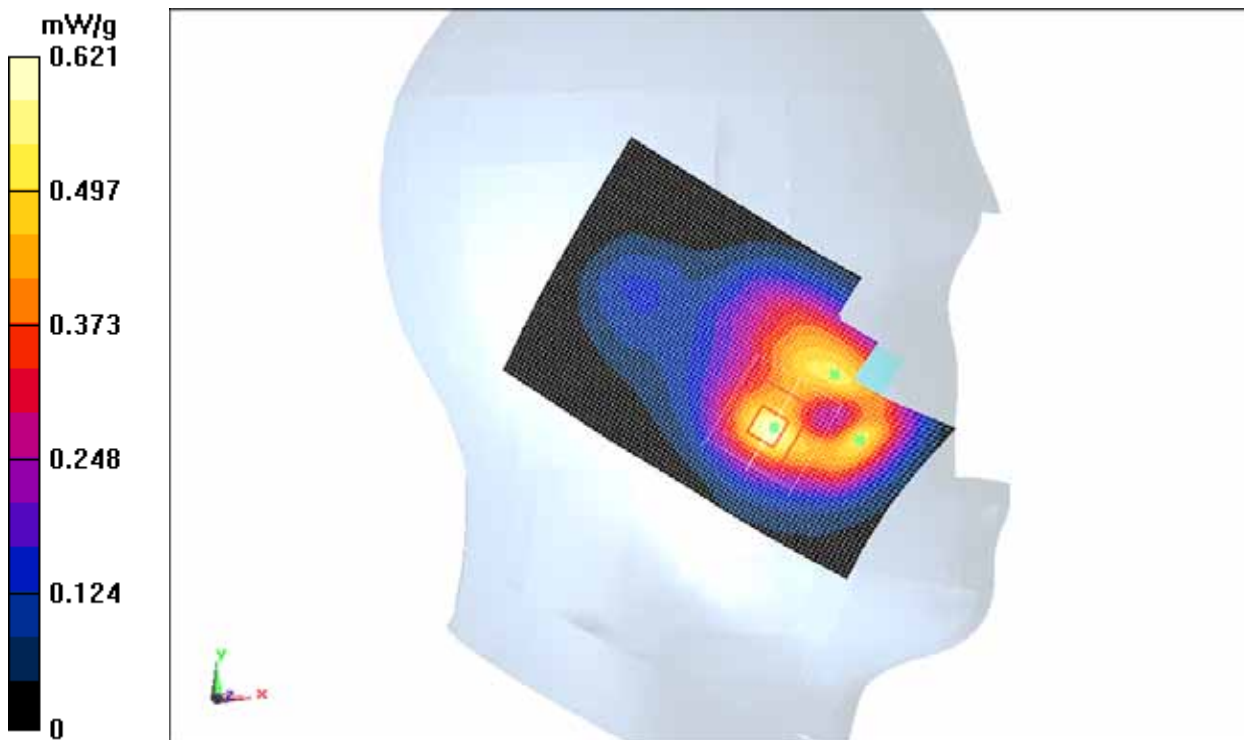

Fig. 21 1900 MHz CH810

1900 Left Cheek Middle

Date: 2012-3-1

Electronics: DAE4 Sn771

Medium: Head GSM1900

Medium parameters used: $f = 1880 \text{ MHz}$; $\sigma = 1.38 \text{ mho/m}$; $\epsilon_r = 40.6$; $\rho = 1000 \text{ kg/m}^3$

Ambient Temperature: 23.0°C Liquid Temperature: 22.5°C

Communication System: GSM 1900MHz Frequency: 1880 MHz Duty Cycle: 1:8.3

Probe: ES3DV3 - SN3149 ConvF(5.03, 5.03, 5.03)

Cheek Middle/Area Scan (61x91x1): Measurement grid: $dx=10\text{mm}$, $dy=10\text{mm}$
Maximum value of SAR (interpolated) = 0.639 mW/g

Cheek Middle/Zoom Scan (7x7x7)/Cube 0: Measurement grid: $dx=5\text{mm}$, $dy=5\text{mm}$, $dz=5\text{mm}$

Reference Value = 10.707 V/m; Power Drift = 0.02 dB

Peak SAR (extrapolated) = 0.8750

SAR(1 g) = 0.561 mW/g; SAR(10 g) = 0.323 mW/g

Maximum value of SAR (measured) = 0.626 mW/g

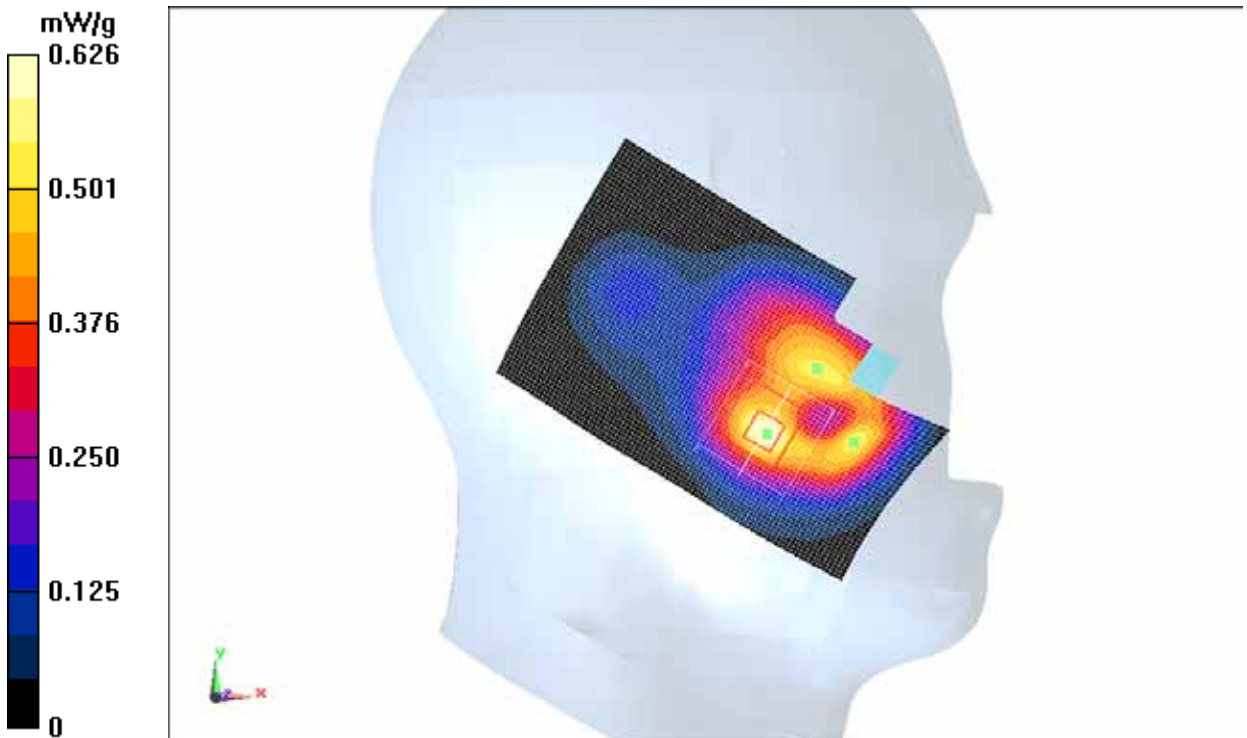

Fig. 22 1900 MHz CH661

1900 Left Cheek Low

Date: 2012-3-1

Electronics: DAE4 Sn771

Medium: Head 1900 MHz

Medium parameters used (interpolated): $f = 1850.2$ MHz; $\sigma = 1.35$ mho/m; $\epsilon_r = 40.8$; $\rho = 1000$ kg/m³

Ambient Temperature: 23.0°C Liquid Temperature: 22.5°C

Communication System: GSM 1900MHz Frequency: 1850.2 MHz Duty Cycle: 1:8.3

Probe: ES3DV3 - SN3149 ConvF(5.03, 5.03, 5.03)

Cheek Low/Area Scan (61x91x1): Measurement grid: dx=10mm, dy=10mm

Maximum value of SAR (interpolated) = 0.629 mW/g

Cheek Low/Zoom Scan (7x7x7)/Cube 0: Measurement grid: dx=5mm, dy=5mm, dz=5mm

Reference Value = 10.537 V/m; Power Drift = 0.04 dB

Peak SAR (extrapolated) = 0.8590

SAR(1 g) = 0.555 mW/g; SAR(10 g) = 0.321 mW/g

Maximum value of SAR (measured) = 0.621 mW/g

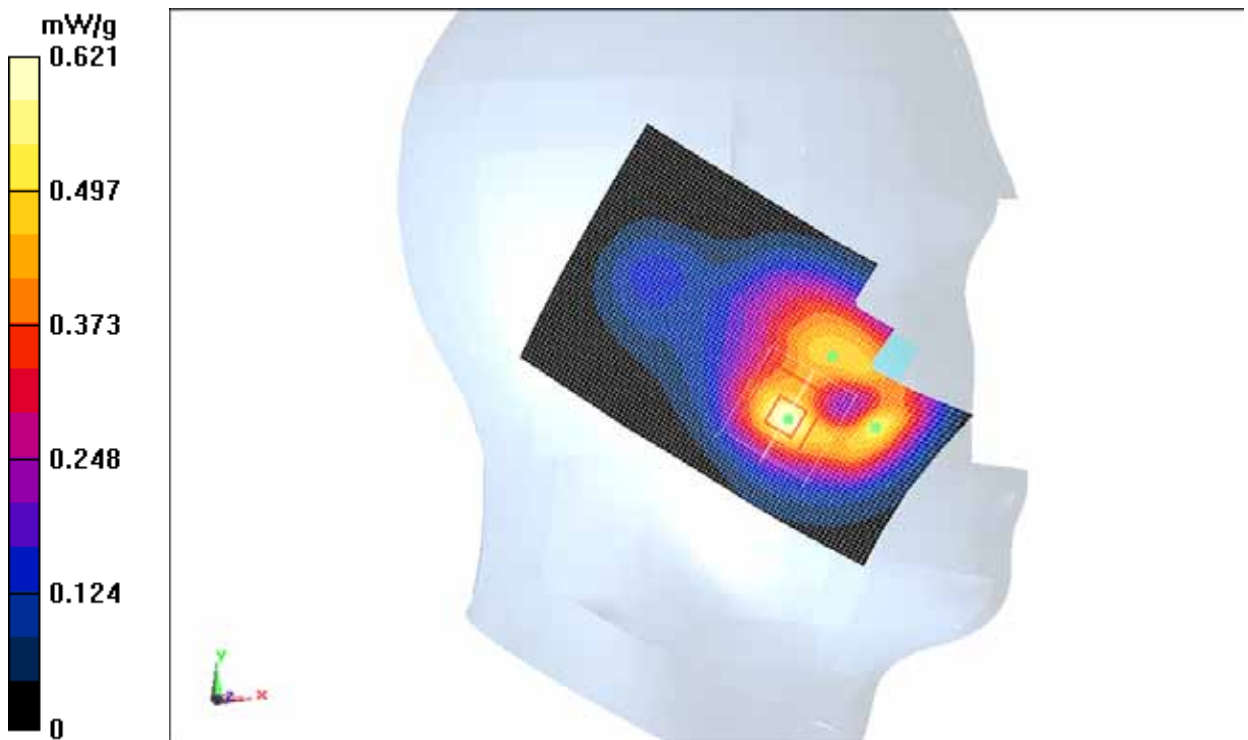

Fig. 23 1900 MHz CH512

1900 Left Tilt High

Date: 2012-3-1

Electronics: DAE4 Sn771

Medium: Head 1900 MHz

Medium parameters used: $f = 1910$ MHz; $\sigma = 1.42$ mho/m; $\epsilon_r = 40.2$; $\rho = 1000$ kg/m³

Ambient Temperature: 23.0°C Liquid Temperature: 22.5°C

Communication System: GSM 1900MHz Frequency: 1909.8 MHz Duty Cycle: 1:8.3

Probe: ES3DV3 - SN3149 ConvF(5.03, 5.03, 5.03)

Tilt High/Area Scan (61x91x1): Measurement grid: dx=10mm, dy=10mm

Maximum value of SAR (interpolated) = 0.276 mW/g

Tilt High/Zoom Scan (7x7x7)/Cube 0: Measurement grid: dx=5mm, dy=5mm, dz=5mm

Reference Value = 14.152 V/m; Power Drift = 0.03 dB

Peak SAR (extrapolated) = 0.4320

SAR(1 g) = 0.264 mW/g; SAR(10 g) = 0.146 mW/g

Maximum value of SAR (measured) = 0.287 mW/g

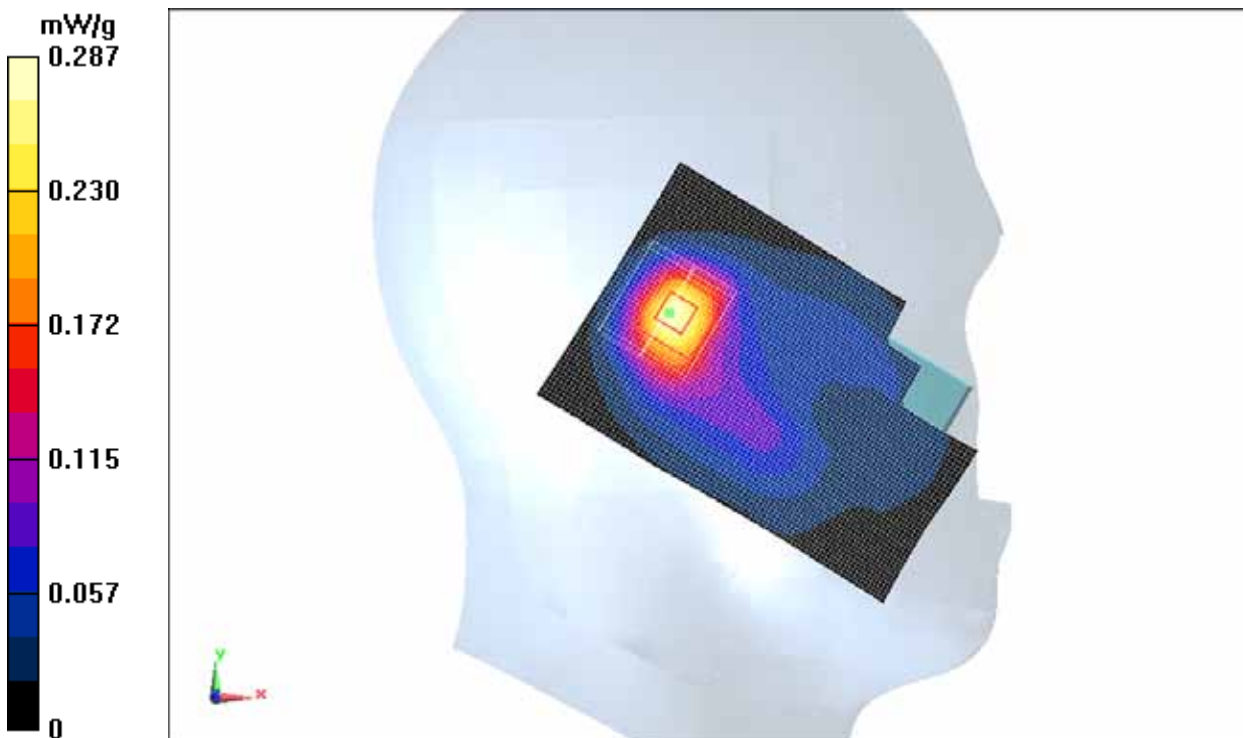

\

Fig. 24 1900 MHz CH810

1900 Left Tilt Middle

Date: 2012-3-1

Electronics: DAE4 Sn771

Medium: Head 1900 MHz

Medium parameters used: $f = 1880$ MHz; $\sigma = 1.38$ mho/m; $\epsilon_r = 40.6$; $\rho = 1000$ kg/m³

Ambient Temperature: 23.0°C Liquid Temperature: 22.5°C

Communication System: GSM 1900MHz Frequency: 1880 MHz Duty Cycle: 1:8.3

Probe: ES3DV3 - SN3149 ConvF(5.03, 5.03, 5.03)

Tilt Middle/Area Scan (61x91x1): Measurement grid: dx=10mm, dy=10mm

Maximum value of SAR (interpolated) = 0.327 mW/g

Tilt Middle/Zoom Scan (7x7x7)/Cube 0: Measurement grid: dx=5mm, dy=5mm, dz=5mm

Reference Value = 15.448 V/m; Power Drift = 0.04 dB

Peak SAR (extrapolated) = 0.5000

SAR(1 g) = 0.305 mW/g; SAR(10 g) = 0.170 mW/g

Maximum value of SAR (measured) = 0.345 mW/g

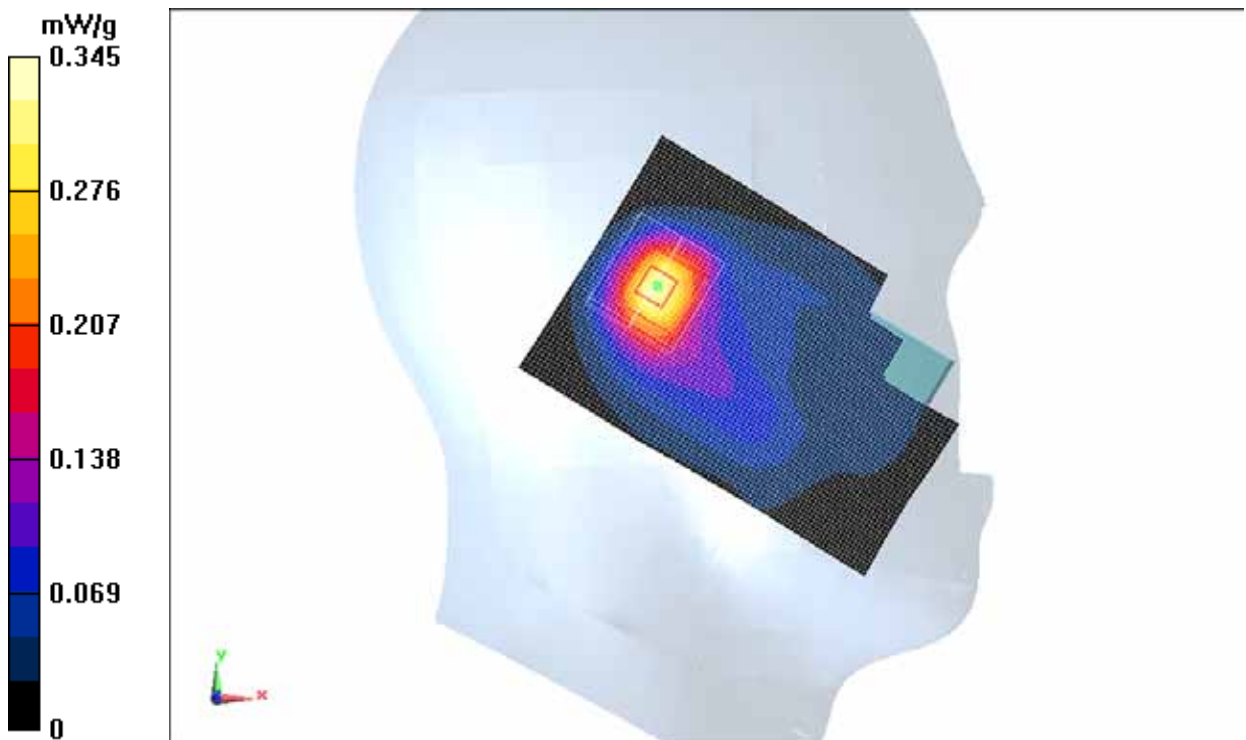

Fig. 25 1900 MHz CH661

1900 Left Tilt Low

Date: 2012-3-1

Electronics: DAE4 Sn771

Medium: Head 1900 MHz

Medium parameters used (interpolated): $f = 1850.2$ MHz; $\sigma = 1.35$ mho/m; $\epsilon_r = 40.8$;
 $\rho = 1000$ kg/m³

Ambient Temperature: 23.0°C Liquid Temperature: 22.5°C

Communication System: GSM 1900MHz Frequency: 1850.2 MHz Duty Cycle: 1:8.3

Probe: ES3DV3 - SN3149 ConvF(5.03, 5.03, 5.03)

Tilt Low/Area Scan (61x91x1): Measurement grid: dx=10mm, dy=10mm
Maximum value of SAR (interpolated) = 0.330 mW/g

Tilt Low/Zoom Scan (7x7x7)/Cube 0: Measurement grid: dx=5mm, dy=5mm,
dz=5mm

Reference Value = 15.596 V/m; Power Drift = 0.04 dB

Peak SAR (extrapolated) = 0.4890

SAR(1 g) = 0.308 mW/g; SAR(10 g) = 0.174 mW/g

Maximum value of SAR (measured) = 0.344 mW/g

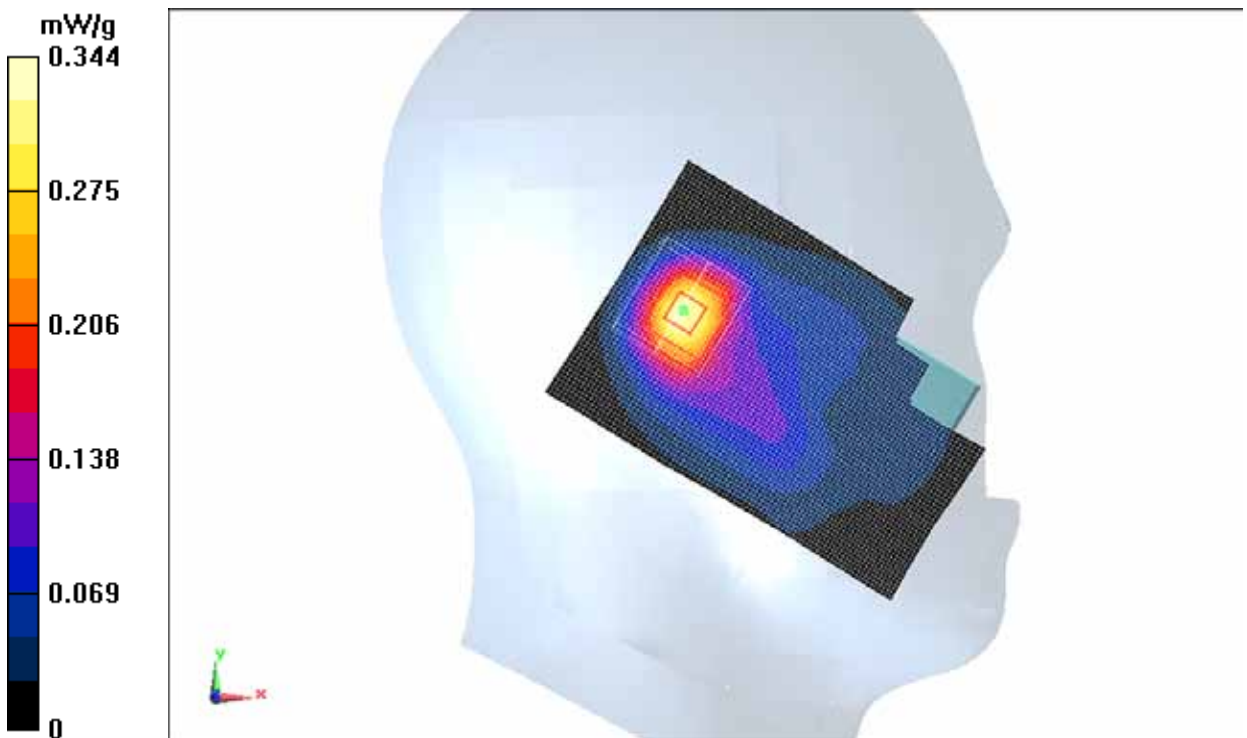

Fig. 26 1900 MHz CH512

1900 Right Cheek High

Date: 2012-3-1

Electronics: DAE4 Sn771

Medium: Head 1900 MHz

Medium parameters used: $f = 1910$ MHz; $\sigma = 1.42$ mho/m; $\epsilon_r = 40.2$; $\rho = 1000$ kg/m³

Ambient Temperature: 23.0°C Liquid Temperature: 22.5°C

Communication System: GSM 1900MHz Frequency: 1909.8 MHz Duty Cycle: 1:8.3

Probe: ES3DV3 - SN3149 ConvF(5.03, 5.03, 5.03)

Cheek High/Area Scan (61x91x1): Measurement grid: dx=10mm, dy=10mm

Maximum value of SAR (interpolated) = 0.832 mW/g

Cheek High/Zoom Scan (7x7x7)/Cube 0: Measurement grid: dx=5mm, dy=5mm, dz=5mm

Reference Value = 9.894 V/m; Power Drift = 0.05 dB

Peak SAR (extrapolated) = 1.2410

SAR(1 g) = 0.715 mW/g; SAR(10 g) = 0.377 mW/g

Maximum value of SAR (measured) = 0.798 mW/g

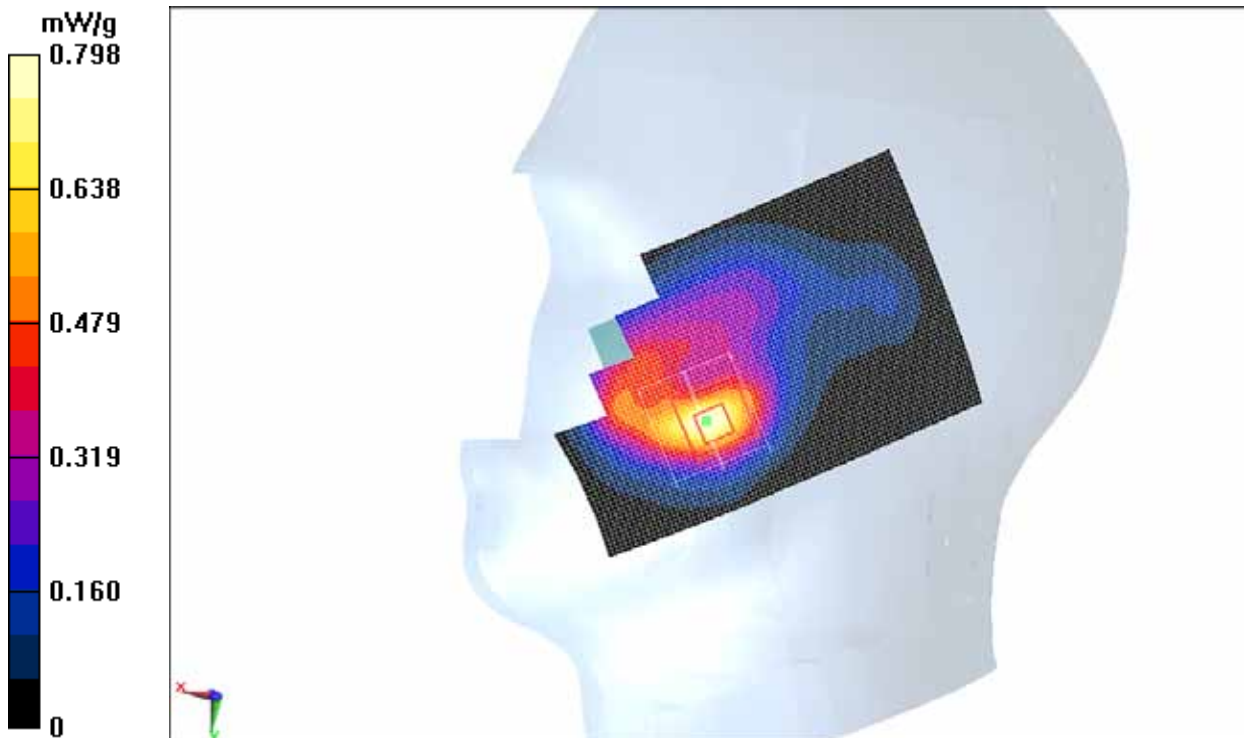

Fig. 27 1900 MHz CH810

1900 Right Cheek Middle

Date: 2012-3-1

Electronics: DAE4 Sn771

Medium: Head 1900 MHz

Medium parameters used: $f = 1880$ MHz; $\sigma = 1.38$ mho/m; $\epsilon_r = 40.6$; $\rho = 1000$ kg/m³

Ambient Temperature: 23.0°C Liquid Temperature: 22.5°C

Communication System: GSM 1900MHz Frequency: 1880 MHz Duty Cycle: 1:8.3

Probe: ES3DV3 - SN3149 ConvF(5.03, 5.03, 5.03)

Cheek Middle/Area Scan (61x91x1): Measurement grid: dx=10mm, dy=10mm
Maximum value of SAR (interpolated) = 0.893 mW/g

Cheek Middle/Zoom Scan (7x7x7)/Cube 0: Measurement grid: dx=5mm, dy=5mm, dz=5mm

Reference Value = 10.636 V/m; Power Drift = -0.07 dB

Peak SAR (extrapolated) = 1.3290

SAR(1 g) = 0.771 mW/g; SAR(10 g) = 0.405 mW/g

Maximum value of SAR (measured) = 0.858 mW/g

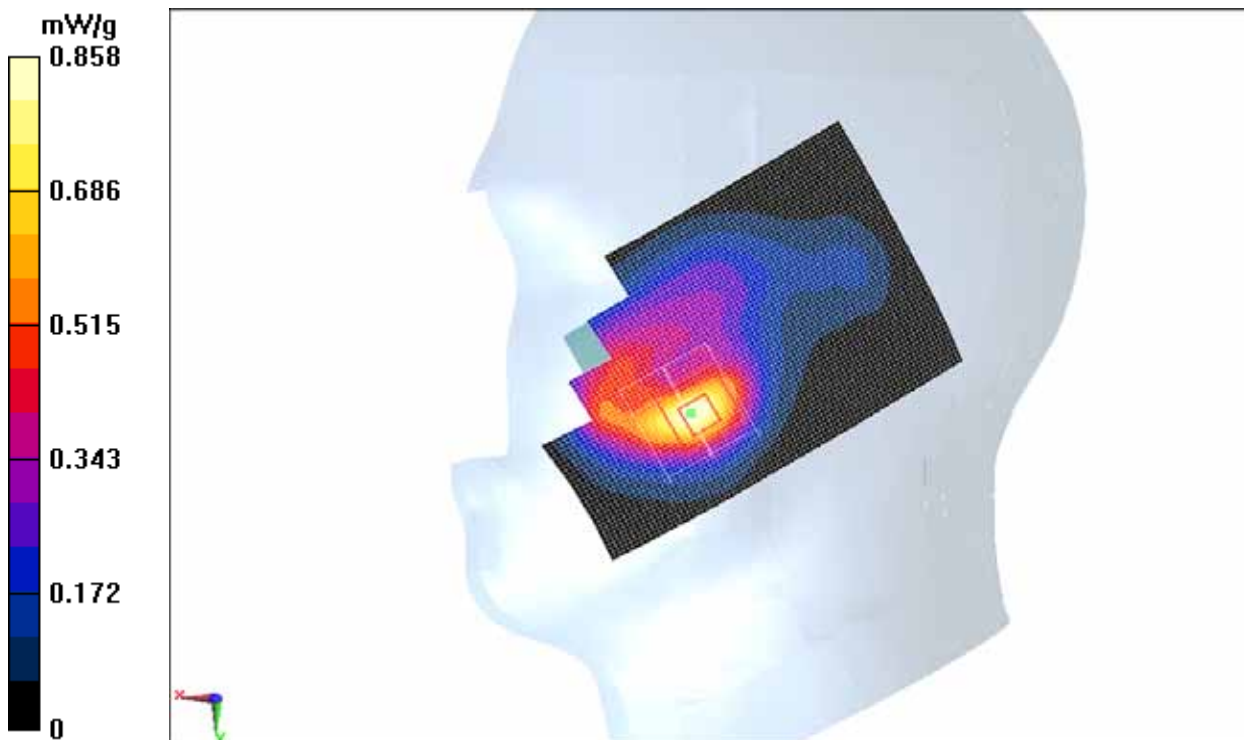

Fig. 28 1900 MHz CH661

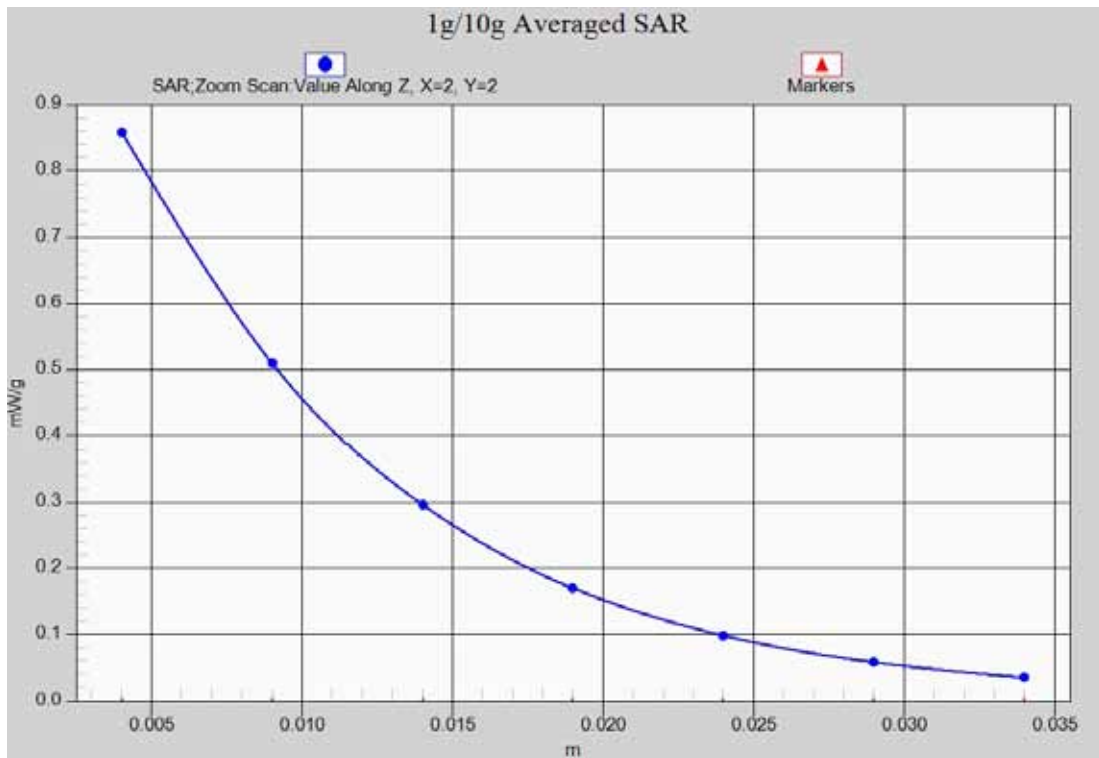

Fig. 28-1 Z-Scan at power reference point (1900 MHz CH661)

1900 Right Cheek Low

Date: 2012-3-1

Electronics: DAE4 Sn771

Medium: Head 1900 MHz

Medium parameters used (interpolated): $f = 1850.2$ MHz; $\sigma = 1.35$ mho/m; $\epsilon_r = 40.8$; $\rho = 1000$ kg/m³

Ambient Temperature: 23.0°C Liquid Temperature: 22.5°C

Communication System: GSM 1900MHz Frequency: 1850.2 MHz Duty Cycle: 1:8.3

Probe: ES3DV3 - SN3149 ConvF(5.03, 5.03, 5.03)

Cheek Low/Area Scan (61x91x1): Measurement grid: dx=10mm, dy=10mm

Maximum value of SAR (interpolated) = 0.843 mW/g

Cheek Low/Zoom Scan (7x7x7)/Cube 0: Measurement grid: dx=5mm, dy=5mm, dz=5mm

Reference Value = 10.024 V/m; Power Drift = 0.07 dB

Peak SAR (extrapolated) = 1.2410

SAR(1 g) = 0.729 mW/g; SAR(10 g) = 0.386 mW/g

Maximum value of SAR (measured) = 0.808 mW/g

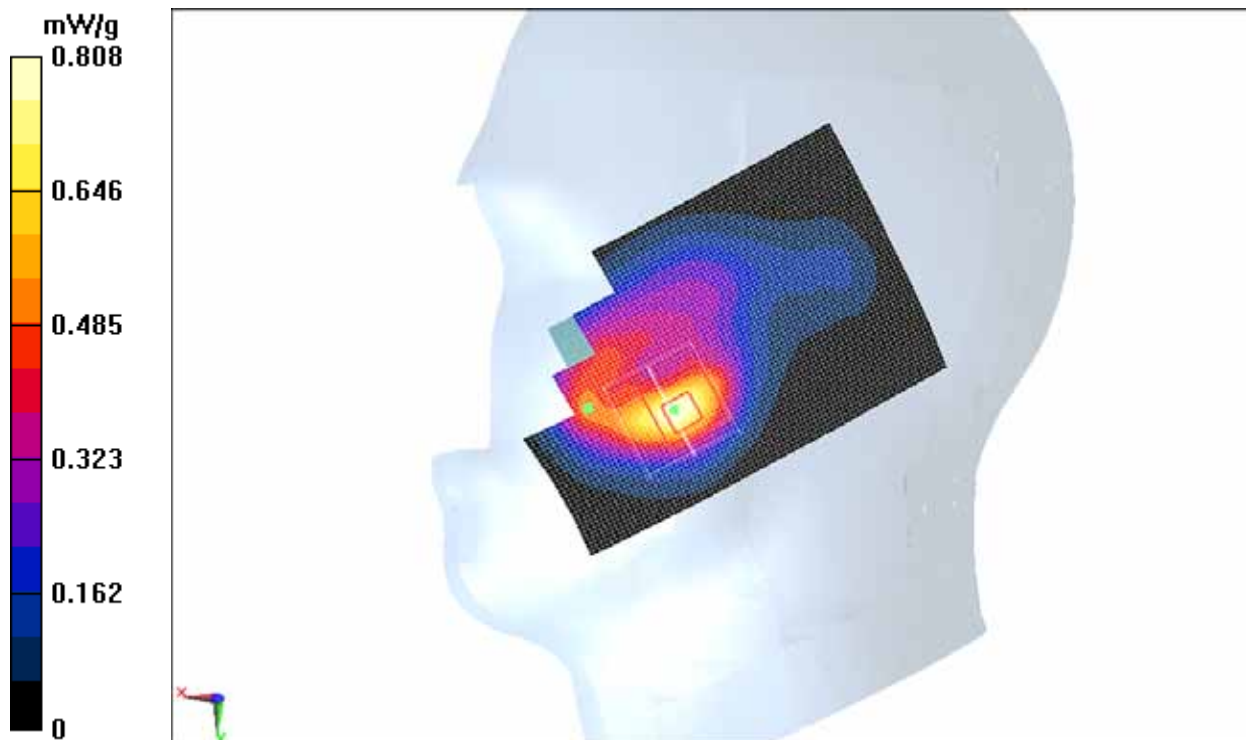

Fig. 29 1900 MHz CH512

1900 Right Tilt High

Date: 2012-3-1

Electronics: DAE4 Sn771

Medium: Head 1900 MHz

Medium parameters used: $f = 1910$ MHz; $\sigma = 1.42$ mho/m; $\epsilon_r = 40.2$; $\rho = 1000$ kg/m³

Ambient Temperature: 23.0°C Liquid Temperature: 22.5°C

Communication System: GSM 1900MHz Frequency: 1909.8 MHz Duty Cycle: 1:8.3

Probe: ES3DV3 - SN3149 ConvF(5.03, 5.03, 5.03)

Tilt High/Area Scan (61x91x1): Measurement grid: dx=10mm, dy=10mm

Maximum value of SAR (interpolated) = 0.288 mW/g

Tilt High/Zoom Scan (7x7x7)/Cube 0: Measurement grid: dx=5mm, dy=5mm, dz=5mm

Reference Value = 14.486 V/m; Power Drift = -0.01 dB

Peak SAR (extrapolated) = 0.4080

SAR(1 g) = 0.252 mW/g; SAR(10 g) = 0.140 mW/g

Maximum value of SAR (measured) = 0.286 mW/g

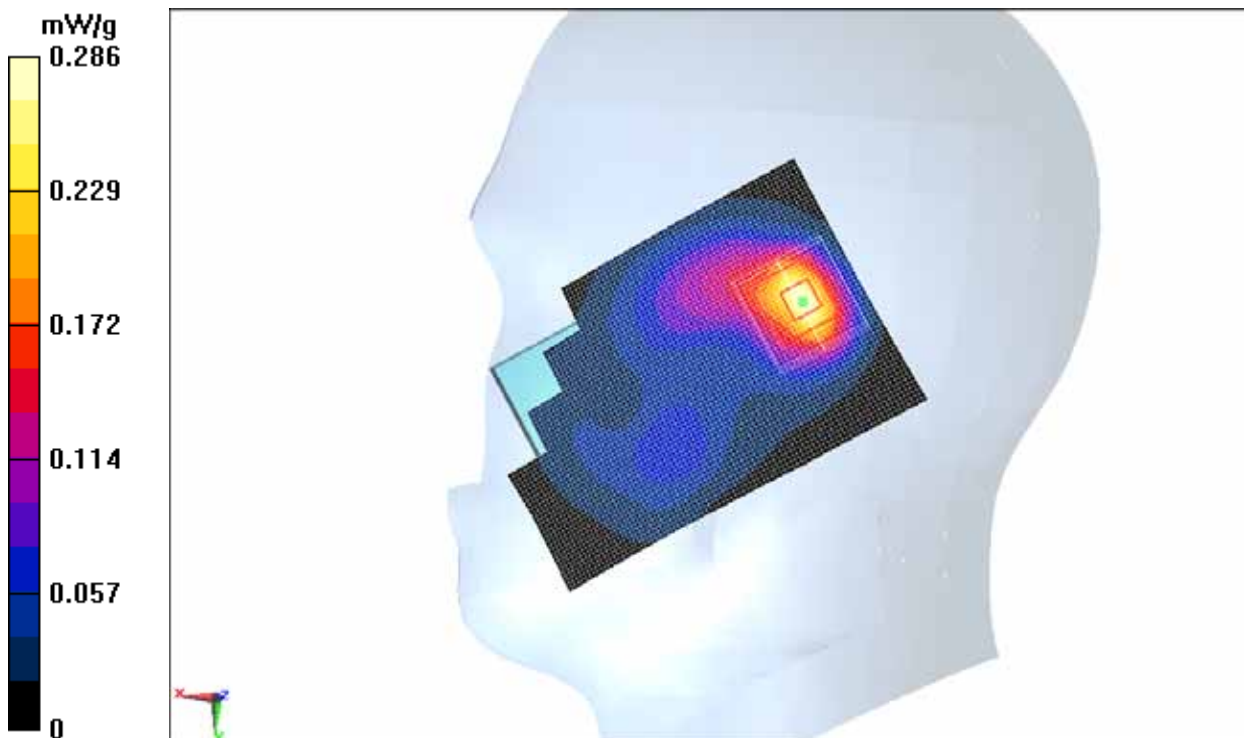

Fig. 30 1900 MHz CH810

1900 Right Tilt Middle

Date: 2012-3-1

Electronics: DAE4 Sn771

Medium: Head 1900 MHz

Medium parameters used: $f = 1880$ MHz; $\sigma = 1.38$ mho/m; $\epsilon_r = 40.6$; $\rho = 1000$ kg/m³

Ambient Temperature: 23.0°C Liquid Temperature: 22.5°C

Communication System: GSM 1900MHz Frequency: 1880 MHz Duty Cycle: 1:8.3

Probe: ES3DV3 - SN3149 ConvF(5.03, 5.03, 5.03)

Tilt Middle/Area Scan (61x91x1): Measurement grid: dx=10mm, dy=10mm

Maximum value of SAR (interpolated) = 0.319 mW/g

Tilt Middle/Zoom Scan (7x7x7)/Cube 0: Measurement grid: dx=5mm, dy=5mm, dz=5mm

Reference Value = 15.310 V/m; Power Drift = 0.0063 dB

Peak SAR (extrapolated) = 0.4380

SAR(1 g) = 0.275 mW/g; SAR(10 g) = 0.154 mW/g

Maximum value of SAR (measured) = 0.311 mW/g

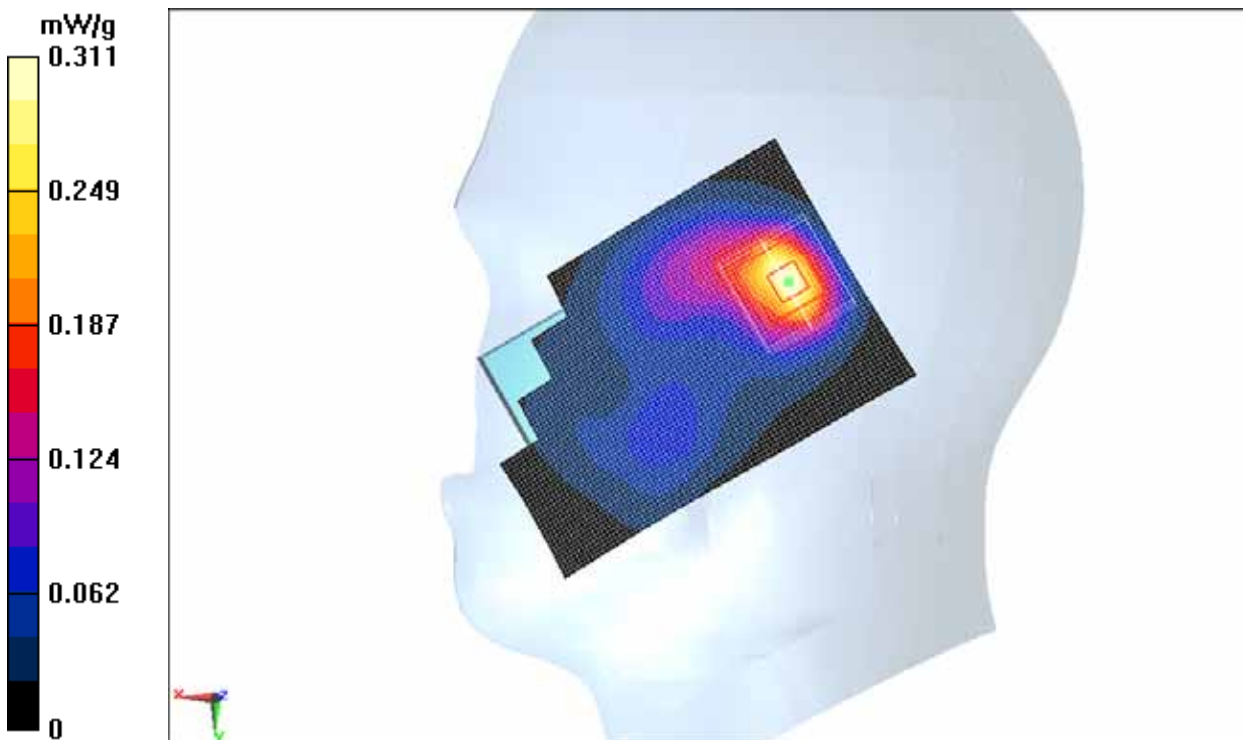

Fig.31 1900 MHz CH661

1900 Right Tilt Low

Date: 2012-3-1

Electronics: DAE4 Sn771

Medium: Head 1900 MHz

Medium parameters used (interpolated): $f = 1850.2$ MHz; $\sigma = 1.35$ mho/m; $\epsilon_r = 40.8$;
 $\rho = 1000$ kg/m³

Ambient Temperature: 23.0°C Liquid Temperature: 22.5°C

Communication System: GSM 1900MHz Frequency: 1850.2 MHz Duty Cycle: 1:8.3

Probe: ES3DV3 - SN3149 ConvF(5.03, 5.03, 5.03)

Tilt Low/Area Scan (61x91x1): Measurement grid: dx=10mm, dy=10mm

Maximum value of SAR (interpolated) = 0.300 mW/g

Tilt Low/Zoom Scan (7x7x7)/Cube 0: Measurement grid: dx=5mm, dy=5mm, dz=5mm

Reference Value = 15.147 V/m; Power Drift = 0.02 dB

Peak SAR (extrapolated) = 0.4160

SAR(1 g) = 0.263 mW/g; SAR(10 g) = 0.149 mW/g

Maximum value of SAR (measured) = 0.298 mW/g

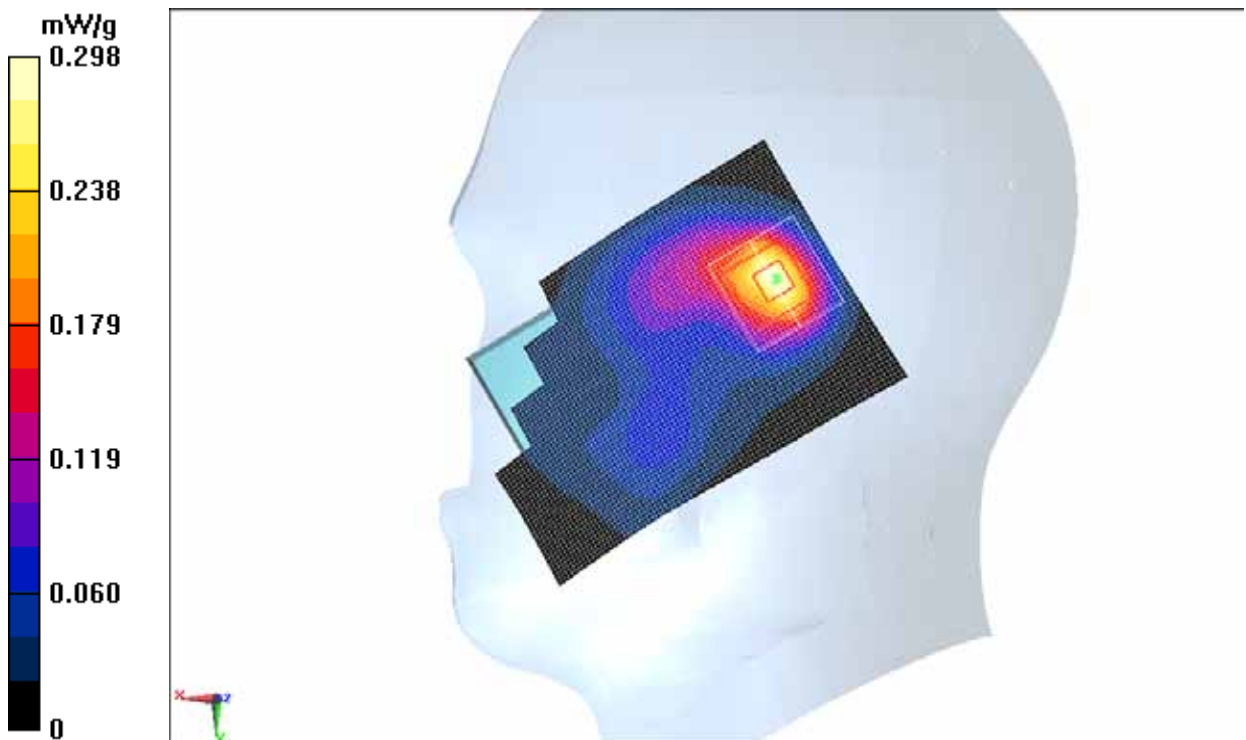

Fig. 32 1900 MHz CH512

1900 Body Towards Phantom High

Date: 2012-3-1

Electronics: DAE4 Sn771

Medium: Body 1900 MHz

Medium parameters used: $f = 1910$ MHz; $\sigma = 1.524$ mho/m; $\epsilon_r = 53.199$; $\rho = 1000$ kg/m³

Ambient Temperature: 23.3°C Liquid Temperature: 22.5°C

Communication System: GSM 1900MHz GPRS-3 Frequency: 1909.8 MHz Duty Cycle: 1:2

Probe: ES3DV3 - SN3149 ConvF(4.68, 4.68, 4.68)

Toward Phantom High/Area Scan (61x101x1): Measurement grid: dx=10mm, dy=10mm

Maximum value of SAR (interpolated) = 0.464 mW/g

Toward Phantom High/Zoom Scan (7x7x7)/Cube 0: Measurement grid: dx=5mm, dy=5mm, dz=5mm

Reference Value = 10.767 V/m; Power Drift = -0.05 dB

Peak SAR (extrapolated) = 0.7120

SAR(1 g) = 0.442 mW/g; SAR(10 g) = 0.261 mW/g

Maximum value of SAR (measured) = 0.472 mW/g

Toward Phantom High/Zoom Scan (7x7x7)/Cube 1: Measurement grid: dx=5mm, dy=5mm, dz=5mm

Reference Value = 10.767 V/m; Power Drift = -0.05 dB

Peak SAR (extrapolated) = 0.7140

SAR(1 g) = 0.422 mW/g; SAR(10 g) = 0.248 mW/g

Maximum value of SAR (measured) = 0.486 mW/g

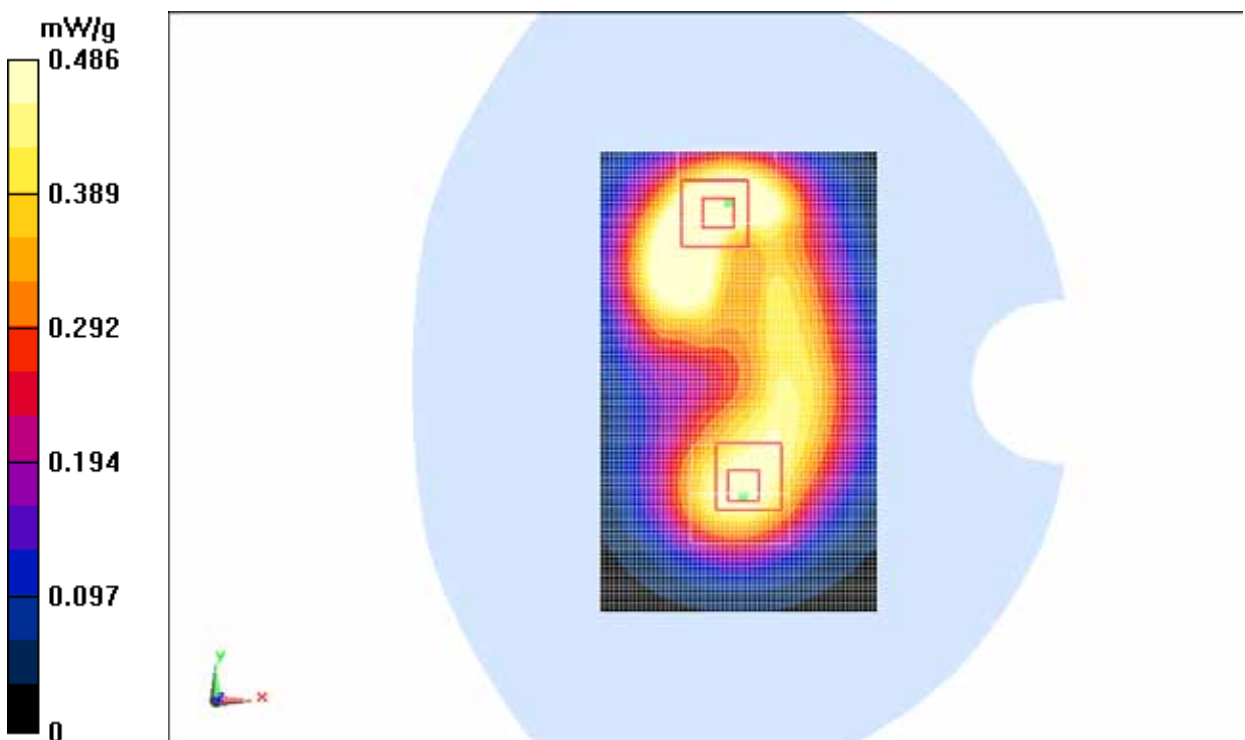

Fig. 33 1900 MHz CH810

1900 Body Towards Phantom Middle

Date: 2012-3-1

Electronics: DAE4 Sn771

Medium: Body 1900 MHz

Medium parameters used: $f = 1880$ MHz; $\sigma = 1.499$ mho/m; $\epsilon_r = 53.287$; $\rho = 1000$ kg/m³

Ambient Temperature: 23.3°C Liquid Temperature: 22.5°C

Communication System: GSM 1900MHz GPRS Frequency: 1880 MHz Duty Cycle: 1:2

Probe: ES3DV3 - SN3149 ConvF(4.68, 4.68, 4.68)

Toward Phantom Middle/Area Scan (61x101x1): Measurement grid: dx=10mm, dy=10mm

Maximum value of SAR (interpolated) = 0.499 mW/g

Toward Phantom Middle/Zoom Scan (7x7x7)/Cube 0: Measurement grid: dx=5mm, dy=5mm, dz=5mm

Reference Value = 12.263 V/m; Power Drift = -0.0013 dB

Peak SAR (extrapolated) = 0.7850

SAR(1 g) = 0.482 mW/g; SAR(10 g) = 0.284 mW/g

Maximum value of SAR (measured) = 0.514 mW/g

Toward Phantom Middle/Zoom Scan (7x7x7)/Cube 1: Measurement grid: dx=5mm, dy=5mm, dz=5mm

Reference Value = 12.263 V/m; Power Drift = -0.0013 dB

Peak SAR (extrapolated) = 0.5210

SAR(1 g) = 0.338 mW/g; SAR(10 g) = 0.219 mW/g

Maximum value of SAR (measured) = 0.362 mW/g

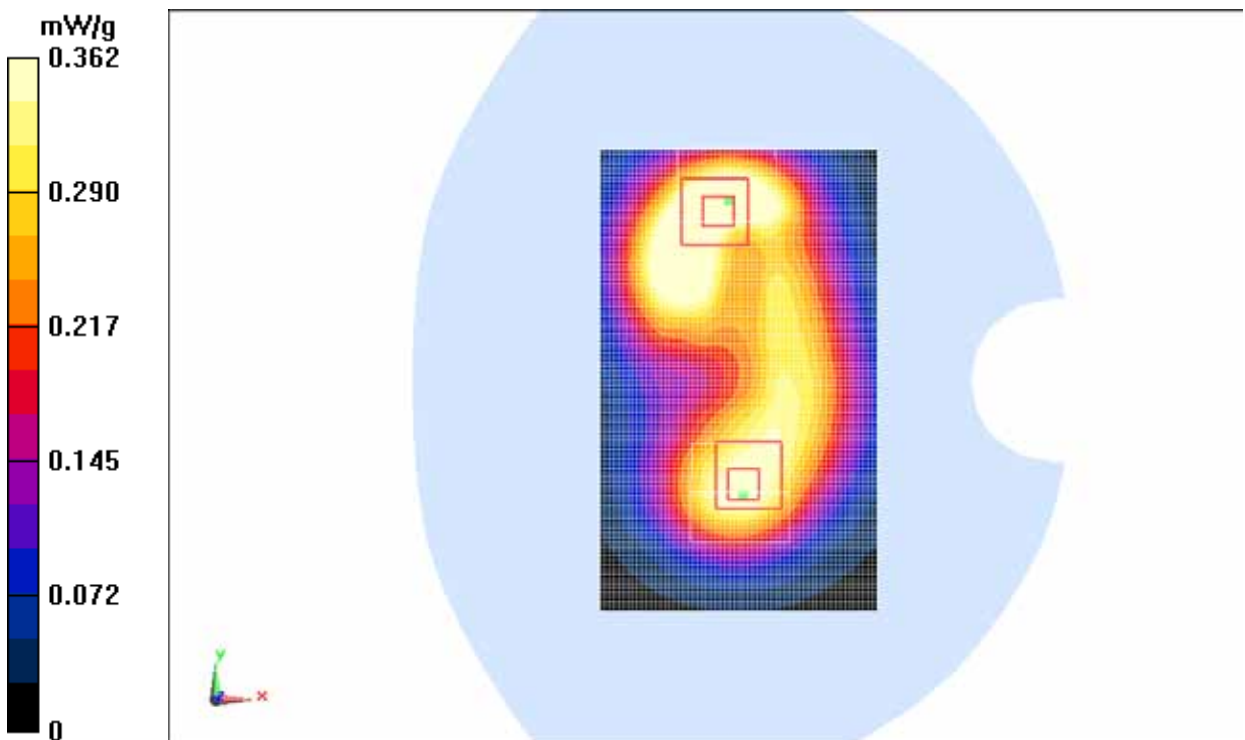

Fig. 34 1900 MHz CH661

1900 Body Towards Phantom Low

Date: 2012-3-1

Electronics: DAE4 Sn771

Medium: Body 1900 MHz

Medium parameters used (interpolated): $f = 1850.2$ MHz; $\sigma = 1.475$ mho/m; $\epsilon_r = 53.406$; $\rho = 1000$ kg/m³

Ambient Temperature: 23.3°C Liquid Temperature: 22.5°C

Communication System: GSM 1900MHz GPRS Frequency: 1850.2 MHz Duty Cycle: 1:2

Probe: ES3DV3 - SN3149 ConvF(4.68, 4.68, 4.68)

Toward Phantom Low/Area Scan (61x101x1): Measurement grid: dx=10mm, dy=10mm

Maximum value of SAR (interpolated) = 0.480 mW/g

Toward Phantom Low/Zoom Scan (7x7x7)/Cube 0: Measurement grid: dx=5mm, dy=5mm, dz=5mm

Reference Value = 13.168 V/m; Power Drift = 0.02 dB

Peak SAR (extrapolated) = 0.7450

SAR(1 g) = 0.463 mW/g; SAR(10 g) = 0.275 mW/g

Maximum value of SAR (measured) = 0.493 mW/g

Toward Phantom Low/Zoom Scan (7x7x7)/Cube 1: Measurement grid: dx=5mm, dy=5mm, dz=5mm

Reference Value = 13.168 V/m; Power Drift = 0.02 dB

Peak SAR (extrapolated) = 0.5060

SAR(1 g) = 0.332 mW/g; SAR(10 g) = 0.218 mW/g

Maximum value of SAR (measured) = 0.351 mW/g

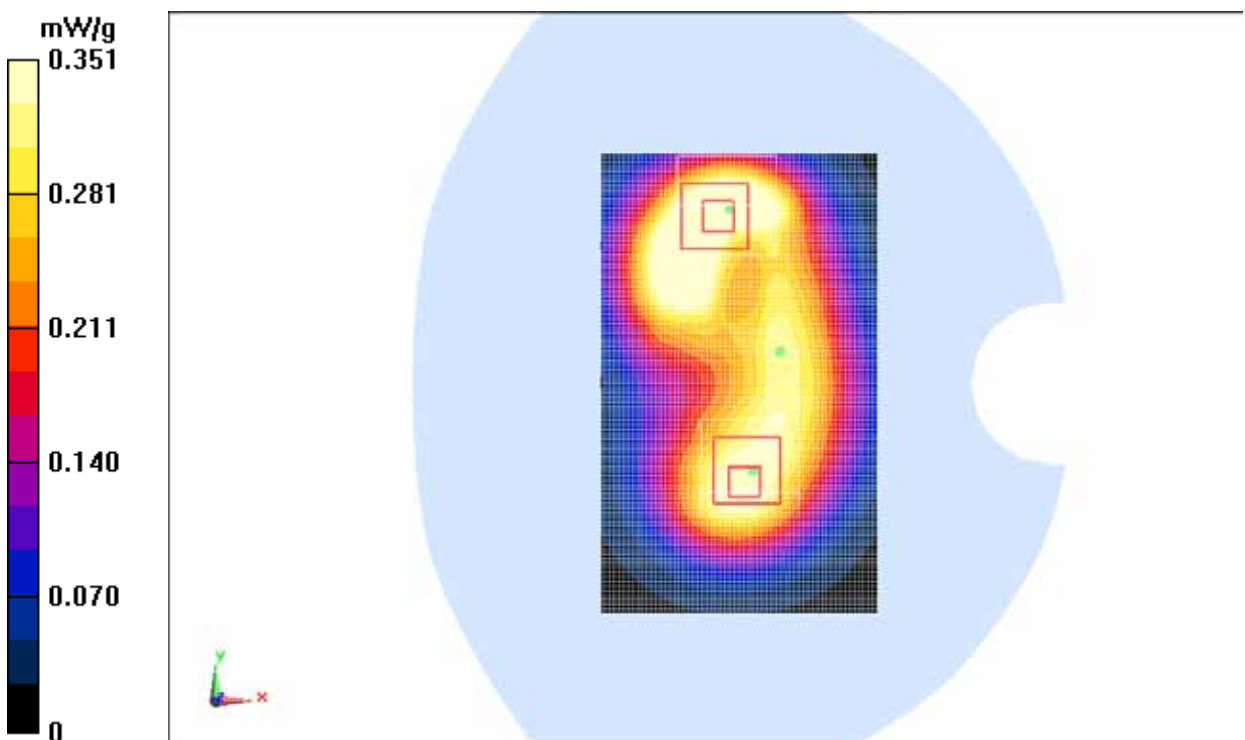

Fig. 35 1900 MHz CH512

1900 Body Towards Ground High

Date: 2012-3-1

Electronics: DAE4 Sn771

Medium: Body 1900 MHz

Medium parameters used: $f = 1910$ MHz; $\sigma = 1.524$ mho/m; $\epsilon_r = 53.199$; $\rho = 1000$ kg/m³

Ambient Temperature: 23.3°C Liquid Temperature: 22.5°C

Communication System: GSM 1900MHz GPRS-3 Frequency: 1909.8 MHz Duty Cycle: 1:2

Probe: ES3DV3 - SN3149 ConvF(4.68, 4.68, 4.68)

Toward Ground High/Area Scan (61x101x1): Measurement grid: dx=10mm, dy=10mm

Maximum value of SAR (interpolated) = 0.568 mW/g

Toward Ground High/Zoom Scan (7x7x7)/Cube 0: Measurement grid: dx=5mm, dy=5mm, dz=5mm

Reference Value = 9.986 V/m; Power Drift = 0.04 dB

Peak SAR (extrapolated) = 0.8630

SAR(1 g) = 0.516 mW/g; SAR(10 g) = 0.304 mW/g

Maximum value of SAR (measured) = 0.553 mW/g

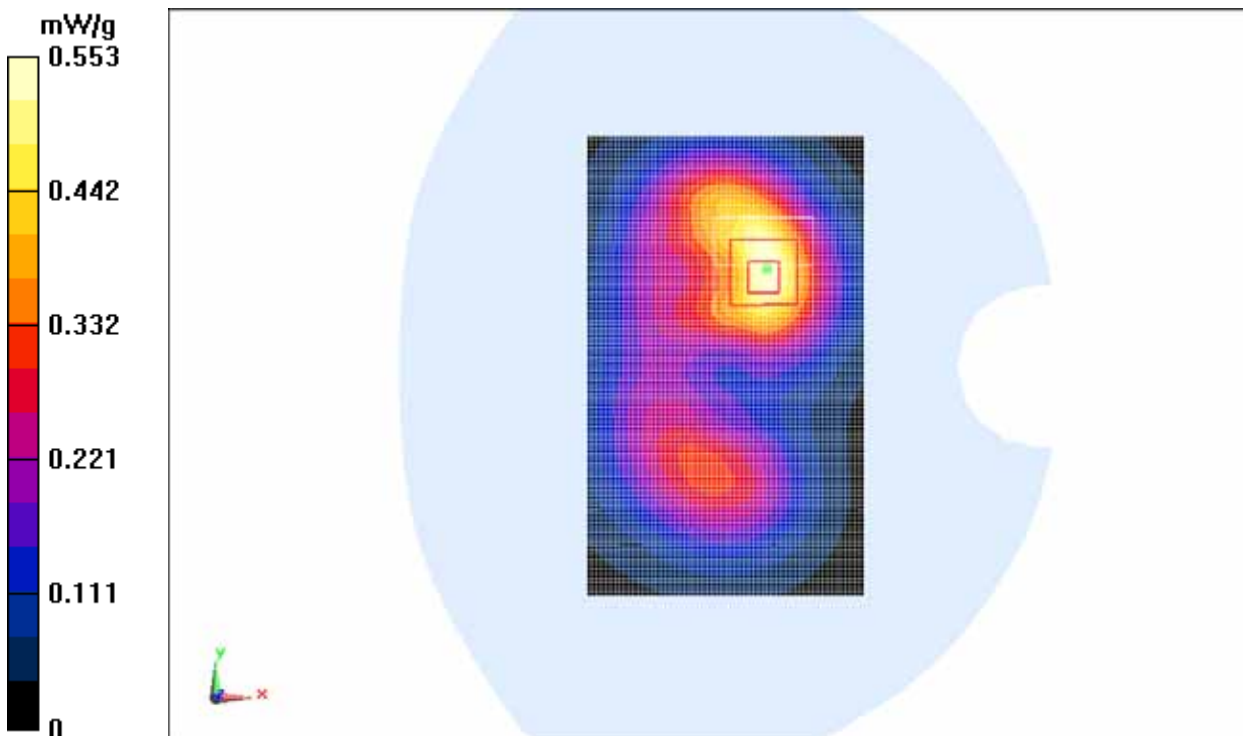

Fig. 36 1900 MHz CH810

1900 Body Towards Ground Middle

Date: 2012-3-1

Electronics: DAE4 Sn771

Medium: Body 1900 MHz

Medium parameters used: $f = 1880$ MHz; $\sigma = 1.499$ mho/m; $\epsilon_r = 53.287$; $\rho = 1000$ kg/m³

Ambient Temperature: 23.3°C Liquid Temperature: 22.5°C

Communication System: GSM 1900MHz GPRS Frequency: 1880 MHz Duty Cycle: 1:2

Probe: ES3DV3 - SN3149 ConvF(4.68, 4.68, 4.68)

Toward Ground Middle/Area Scan (61x101x1): Measurement grid: dx=10mm, dy=10mm

Maximum value of SAR (interpolated) = 0.599 mW/g

Toward Ground Middle/Zoom Scan (7x7x7)/Cube 0: Measurement grid: dx=5mm, dy=5mm, dz=5mm

Reference Value = 11.319 V/m; Power Drift = 0.0061 dB

Peak SAR (extrapolated) = 0.9140

SAR(1 g) = 0.544 mW/g; SAR(10 g) = 0.322 mW/g

Maximum value of SAR (measured) = 0.589 mW/g

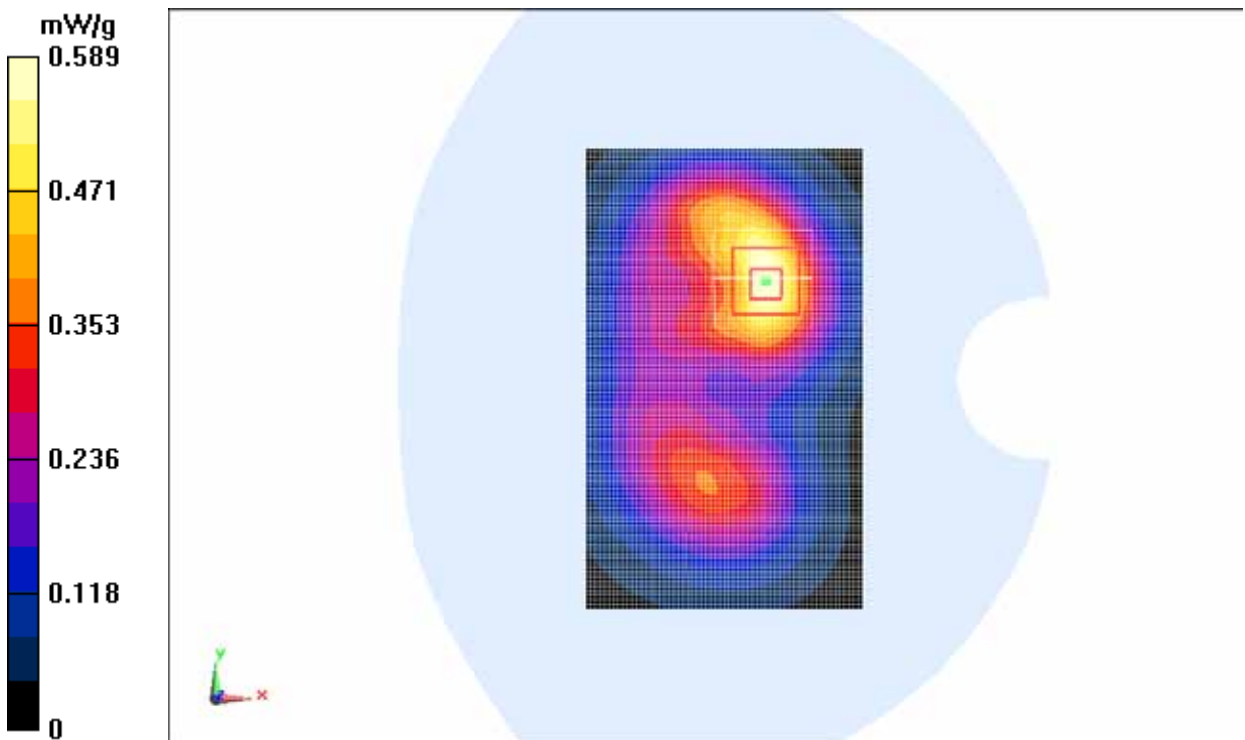

Fig. 37 1900 MHz CH661

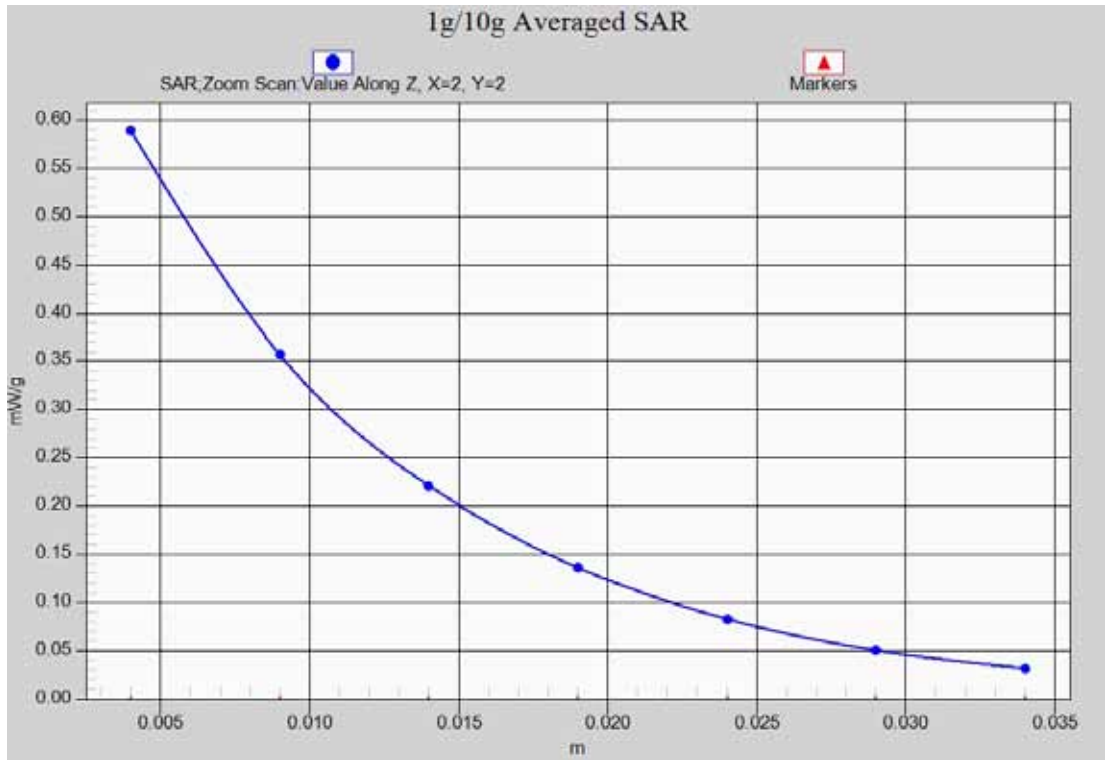

Fig. 37-1 Z-Scan at power reference point (1900 MHz CH661)

900 Body Towards Ground Low

Date: 2012-3-1

Electronics: DAE4 Sn771

Medium: Body 1900 MHz

Medium parameters used (interpolated): $f = 1850.2$ MHz; $\sigma = 1.475$ mho/m; $\epsilon_r = 53.406$; $\rho = 1000$ kg/m³

Ambient Temperature: 23.3°C Liquid Temperature: 22.5°C

Communication System: GSM 1900MHz GPRS Frequency: 1850.2 MHz Duty Cycle: 1:2

Probe: ES3DV3 - SN3149 ConvF(4.68, 4.68, 4.68)

Toward Ground Low/Area Scan (61x101x1): Measurement grid: dx=10mm, dy=10mm

Maximum value of SAR (interpolated) = 0.574 mW/g

Toward Ground Low/Zoom Scan (7x7x7)/Cube 0: Measurement grid: dx=5mm, dy=5mm, dz=5mm

Reference Value = 12.228 V/m; Power Drift = 0.04 dB

Peak SAR (extrapolated) = 0.8630

SAR(1 g) = 0.525 mW/g; SAR(10 g) = 0.314 mW/g

Maximum value of SAR (measured) = 0.570 mW/g

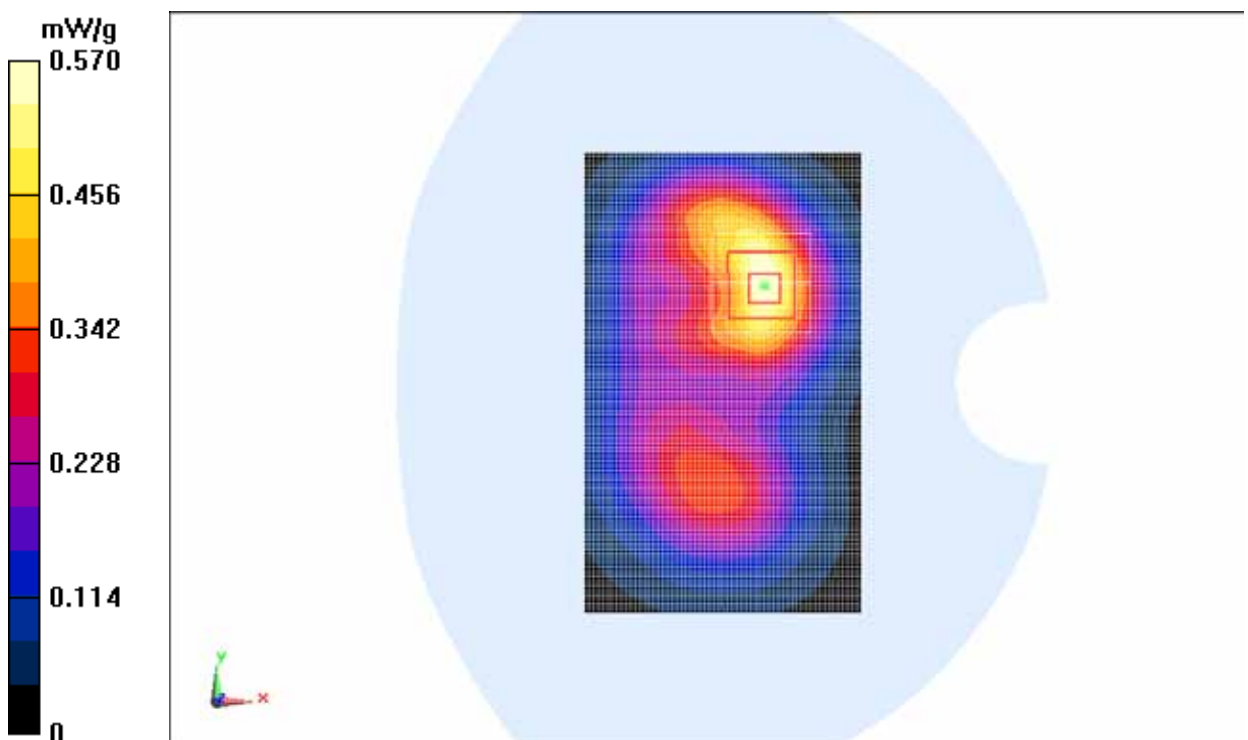

Fig. 38 1900 MHz CH512

1900 Body Towards Ground Middle With Headset CCB3160A11C1

Date: 2012-3-1

Electronics: DAE4 Sn771

Medium: Body 1900 MHz

Medium parameters used: $f = 1880$ MHz; $\sigma = 1.499$ mho/m; $\epsilon_r = 53.287$; $\rho = 1000$ kg/m³

Ambient Temperature: 23.3°C Liquid Temperature: 22.5°C

Communication System: GSM 1900MHz GPRS Frequency: 1880 MHz Duty Cycle: 1:2

Probe: ES3DV3 - SN3149 ConvF(4.68, 4.68, 4.68)

Toward Ground Middle/Area Scan (61x101x1): Measurement grid: dx=10mm, dy=10mm

Maximum value of SAR (interpolated) = 0.312 mW/g

Toward Ground Middle/Zoom Scan (7x7x7)/Cube 0: Measurement grid: dx=5mm, dy=5mm, dz=5mm

Reference Value = 7.310 V/m; Power Drift = 0.03 dB

Peak SAR (extrapolated) = 0.4860

SAR(1 g) = 0.293 mW/g; SAR(10 g) = 0.172 mW/g

Maximum value of SAR (measured) = 0.313 mW/g

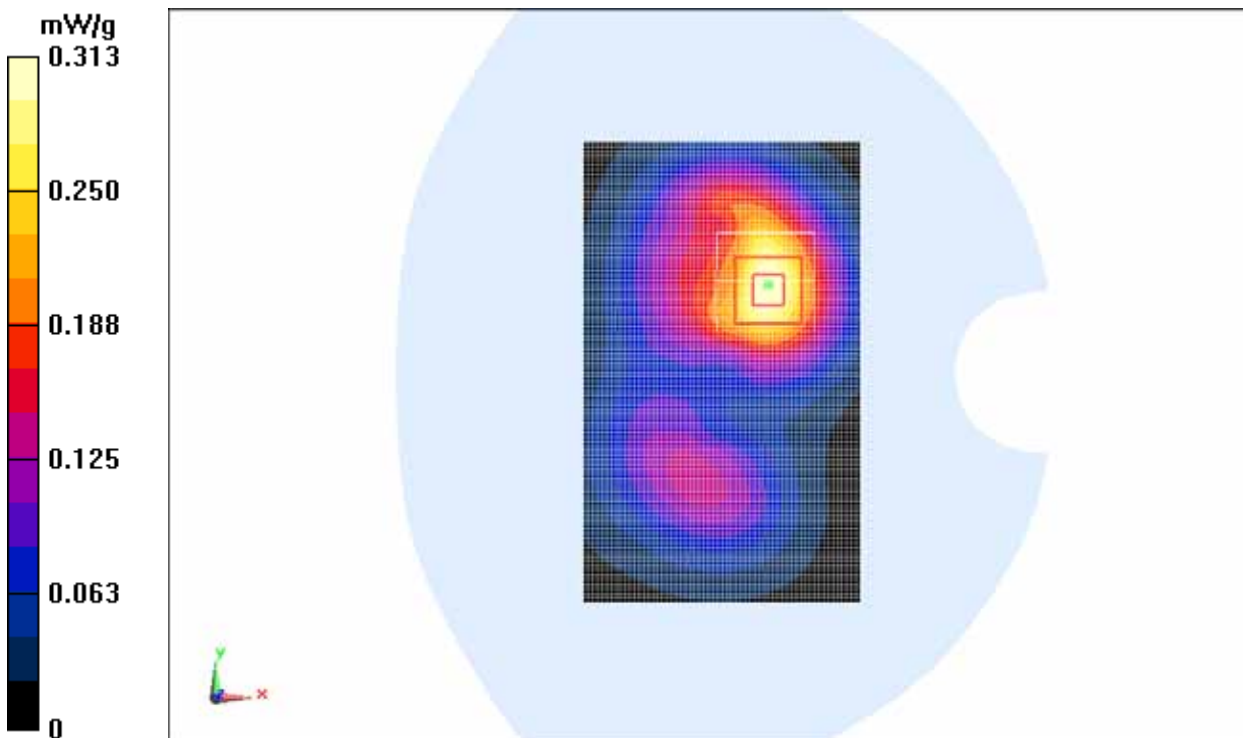

Fig. 39 1900 MHz CH661

1900 Body Towards Ground Middle With Headset CCB3160A11C2

Date: 2012-3-1

Electronics: DAE4 Sn771

Medium: Body 1900 MHz

Medium parameters used: $f = 1880$ MHz; $\sigma = 1.499$ mho/m; $\epsilon_r = 53.287$; $\rho = 1000$ kg/m³

Ambient Temperature: 23.3°C Liquid Temperature: 22.5°C

Communication System: GSM 1900MHz GPRS Frequency: 1880 MHz Duty Cycle: 1:2

Probe: ES3DV3 - SN3149 ConvF(4.68, 4.68, 4.68)

Toward Ground Middle/Area Scan (61x101x1): Measurement grid: dx=10mm, dy=10mm

Maximum value of SAR (interpolated) = 0.284 mW/g

Toward Ground Middle/Zoom Scan (7x7x7)/Cube 0: Measurement grid: dx=5mm, dy=5mm, dz=5mm

Reference Value = 6.563 V/m; Power Drift = 0.05 dB

Peak SAR (extrapolated) = 0.4440

SAR(1 g) = 0.263 mW/g; SAR(10 g) = 0.154 mW/g

Maximum value of SAR (measured) = 0.280 mW/g

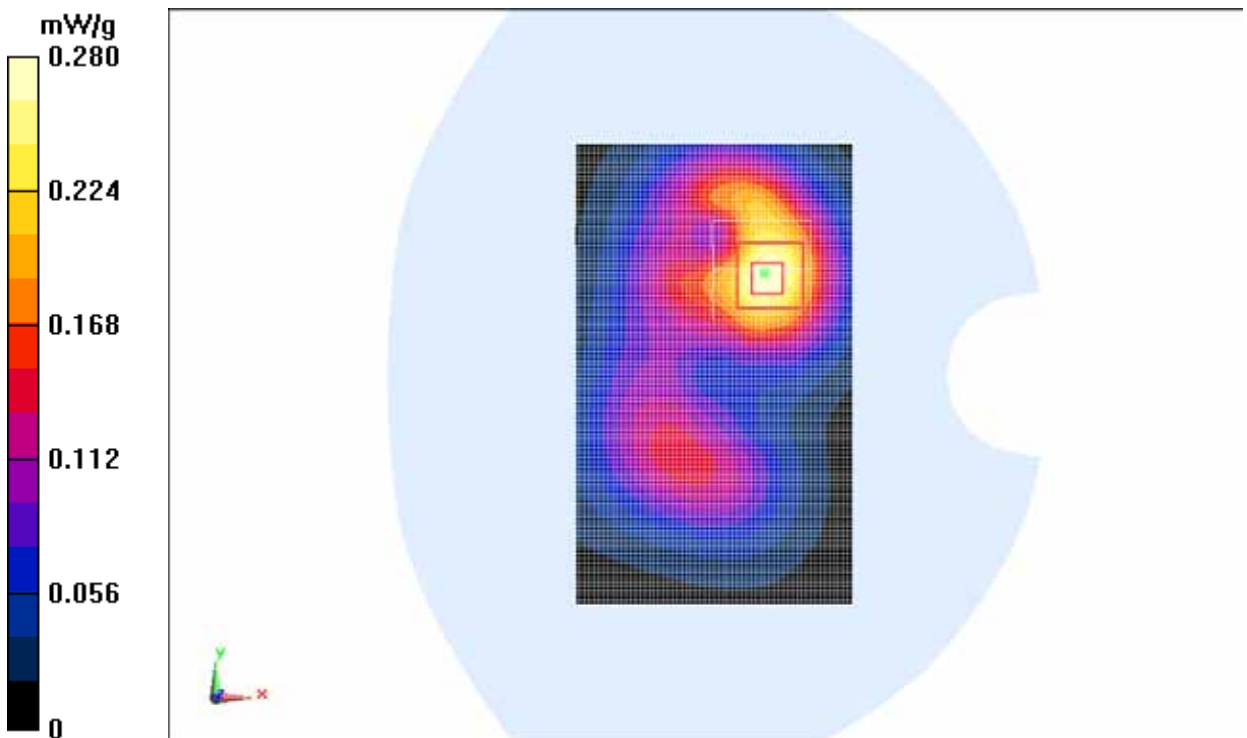

Fig. 40 1900 MHz CH661

Wifi Left Cheek High

Date: 2012-2-26

Electronics: DAE4 Sn771

Medium: Head 2450 MHz

Medium parameters used (interpolated): $f = 2462$ MHz; $\sigma = 1.835$ mho/m; $\epsilon_r = 38.43$; $\rho = 1000$ kg/m³

Ambient Temperature: 23.3°C Liquid Temperature: 22.5°C

Communication System: WLAN 2450 Frequency: 2462 MHz Duty Cycle: 1:1

Probe: ES3DV3 - SN3149 ConvF(4.35, 4.35, 4.35)

Cheek High/Area Scan (61x91x1): Measurement grid: dx=10mm, dy=10mm

Maximum value of SAR (interpolated) = 0.196 mW/g

Cheek High/Zoom Scan (7x7x7)/Cube 0: Measurement grid: dx=5mm, dy=5mm, dz=5mm

Reference Value = 10.597 V/m; Power Drift = 0.18 dB

Peak SAR (extrapolated) = 0.3640

SAR(1 g) = 0.178 mW/g; SAR(10 g) = 0.102 mW/g

Maximum value of SAR (measured) = 0.200 mW/g

Cheek High/Zoom Scan (7x7x7)/Cube 1: Measurement grid: dx=5mm, dy=5mm, dz=5mm

Reference Value = 10.597 V/m; Power Drift = 0.18 dB

Peak SAR (extrapolated) = 0.3410

SAR(1 g) = 0.190 mW/g; SAR(10 g) = 0.105 mW/g

Maximum value of SAR (measured) = 0.214 mW/g

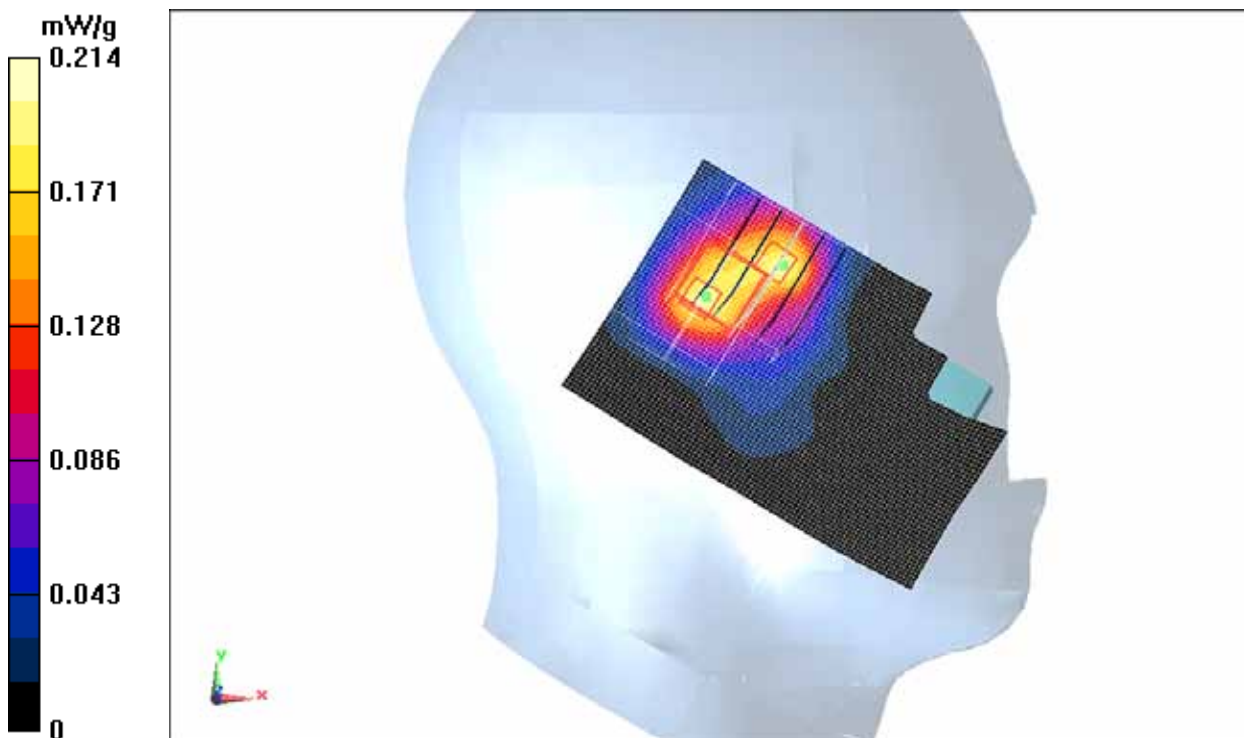

Fig. 41 2450 MHz CH11

Wifi Left Tilt High

Date: 2012-2-26

Electronics: DAE4 Sn771

Medium: Head 2450 MHz

Medium parameters used (interpolated): $f = 2462$ MHz; $\sigma = 1.835$ mho/m; $\epsilon_r = 38.43$;
 $\rho = 1000$ kg/m³

Ambient Temperature: 23.3°C Liquid Temperature: 22.5°C

Communication System: Wlan 2450 Frequency: 2462 MHz Duty Cycle: 1:1

Probe: ES3DV3 - SN3149 ConvF(4.35, 4.35, 4.35)

Tilt High/Area Scan (61x91x1): Measurement grid: dx=10mm, dy=10mm
Maximum value of SAR (interpolated) = 0.270 mW/g

Tilt High/Zoom Scan (7x7x7)/Cube 0: Measurement grid: dx=5mm, dy=5mm,
dz=5mm

Reference Value = 12.905 V/m; Power Drift = -0.10 dB

Peak SAR (extrapolated) = 0.4670

SAR(1 g) = 0.255 mW/g; SAR(10 g) = 0.131 mW/g

Maximum value of SAR (measured) = 0.288 mW/g

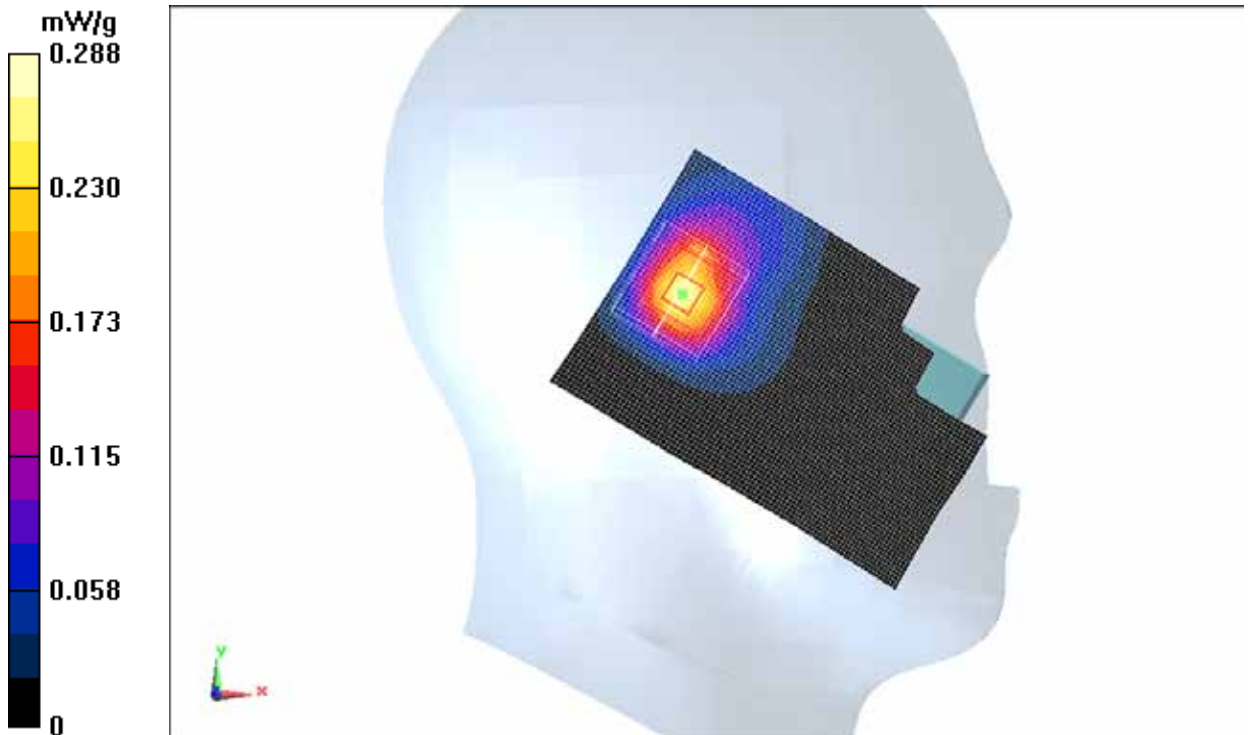

Fig. 42 2450 MHz CH11

Wifi Right Cheek High

Date: 2012-2-26

Electronics: DAE4 Sn771

Medium: Head 2450 MHz

Medium parameters used (interpolated): $f = 2462$ MHz; $\sigma = 1.835$ mho/m; $\epsilon_r = 38.43$;
 $\rho = 1000$ kg/m³

Ambient Temperature: 23.3°C Liquid Temperature: 22.5°C

Communication System: WLAN 2450 Frequency: 2462 MHz Duty Cycle: 1:1

Probe: ES3DV3 - SN3149 ConvF(4.35, 4.35, 4.35)

Cheek High/Area Scan (61x91x1): Measurement grid: dx=10mm, dy=10mm
Maximum value of SAR (interpolated) = 0.265 mW/g

Cheek High/Zoom Scan (7x7x7)/Cube 0: Measurement grid: dx=5mm, dy=5mm,
dz=5mm

Reference Value = 12.933 V/m; Power Drift = -0.13 dB

Peak SAR (extrapolated) = 0.4780

SAR(1 g) = 0.260 mW/g; SAR(10 g) = 0.133 mW/g

Maximum value of SAR (measured) = 0.294 mW/g

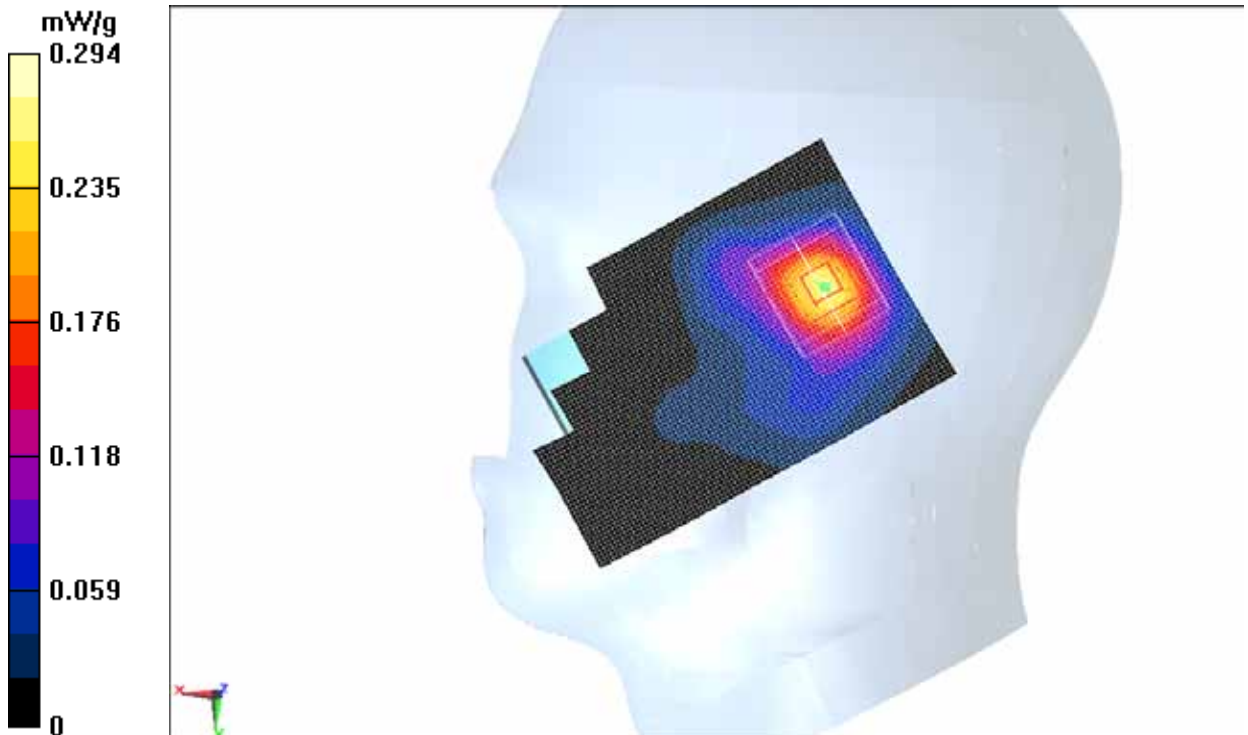

Fig. 43 2450 MHz CH11

Wifi Right Tilt High

Date: 2012-2-26

Electronics: DAE4 Sn771

Medium: Head 2450 MHz

Medium parameters used (interpolated): $f = 2462$ MHz; $\sigma = 1.835$ mho/m; $\epsilon_r = 38.43$;
 $\rho = 1000$ kg/m³

Ambient Temperature: 23.3°C Liquid Temperature: 22.5°C

Communication System: Wlan 2450 Frequency: 2462 MHz Duty Cycle: 1:1

Probe: ES3DV3 - SN3149 ConvF(4.35, 4.35, 4.35)

Tilt High/Area Scan (61x91x1): Measurement grid: dx=10mm, dy=10mm
Maximum value of SAR (interpolated) = 0.342 mW/g

Tilt High/Zoom Scan (7x7x7)/Cube 0: Measurement grid: dx=5mm, dy=5mm,
dz=5mm

Reference Value = 14.503 V/m; Power Drift = -0.19 dB

Peak SAR (extrapolated) = 0.6040

SAR(1 g) = 0.318 mW/g; SAR(10 g) = 0.156 mW/g

Maximum value of SAR (measured) = 0.364 mW/g

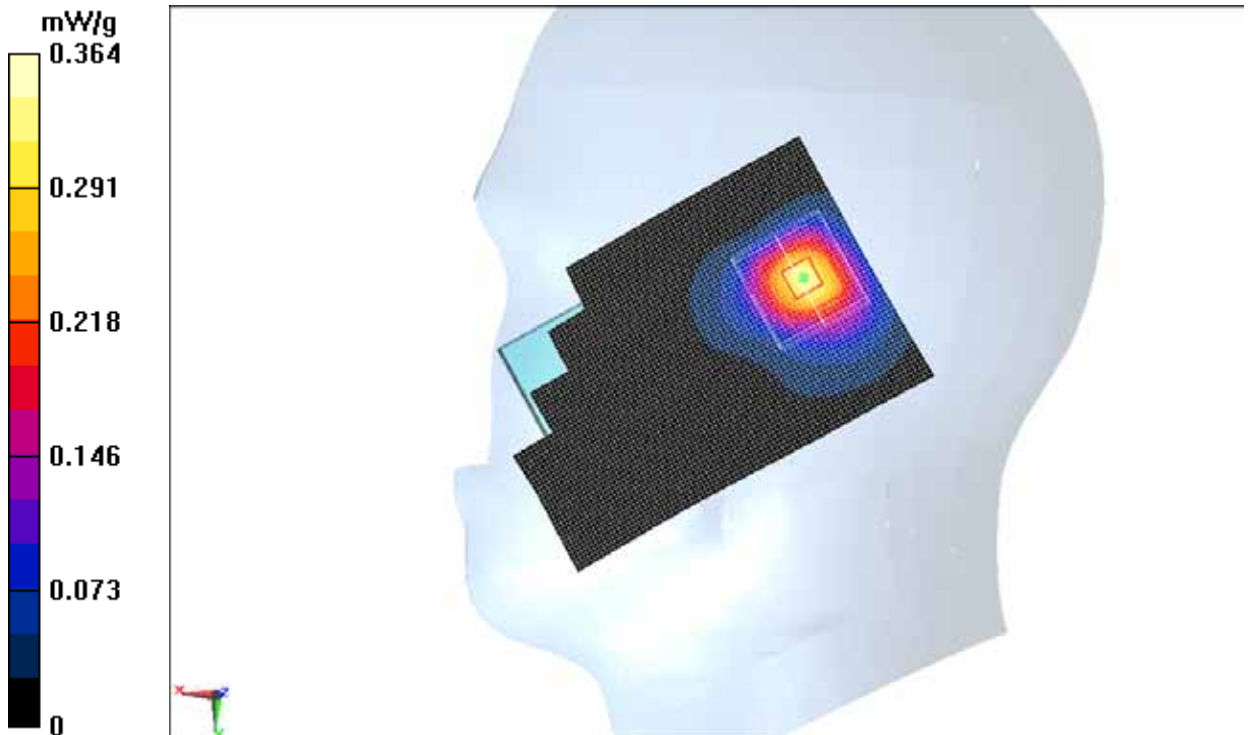

Fig. 44 2450 MHz CH11

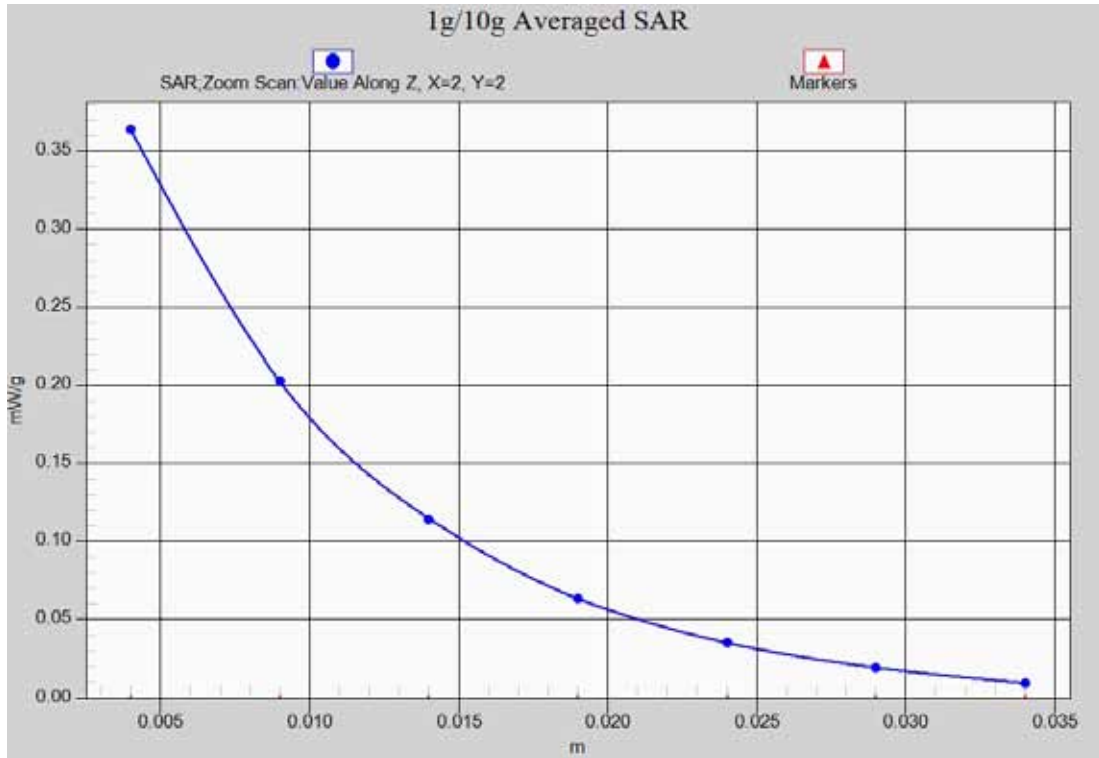

Fig. 44-1 Z-Scan at power reference point (2450 MHz CH11)

Wifi Body Toward Phantom High

Date: 2012-2-26

Electronics: DAE4 Sn771

Medium: 2450 Body

Medium parameters used (interpolated): $f = 2462$ MHz; $\sigma = 1.97$ mho/m; $\epsilon_r = 51.8$;
 $\rho = 1000$ kg/m³

Ambient Temperature: 23.3°C Liquid Temperature: 22.5°C

Communication System: Wlan 2450 Frequency: 2462 MHz Duty Cycle: 1:1

Probe: ES3DV3 - SN3149 ConvF(4.13, 4.13, 4.13)

Toward Phantom High/Area Scan (61x101x1): Measurement grid: dx=10mm, dy=10mm

Maximum value of SAR (interpolated) = 0.070 mW/g

Toward Phantom High/Zoom Scan (7x7x7)/Cube 0: Measurement grid: dx=5mm, dy=5mm, dz=5mm

Reference Value = 2.785 V/m; Power Drift = 0.11 dB

Peak SAR (extrapolated) = 0.1100

SAR(1 g) = 0.064 mW/g; SAR(10 g) = 0.036 mW/g

Maximum value of SAR (measured) = 0.069 mW/g

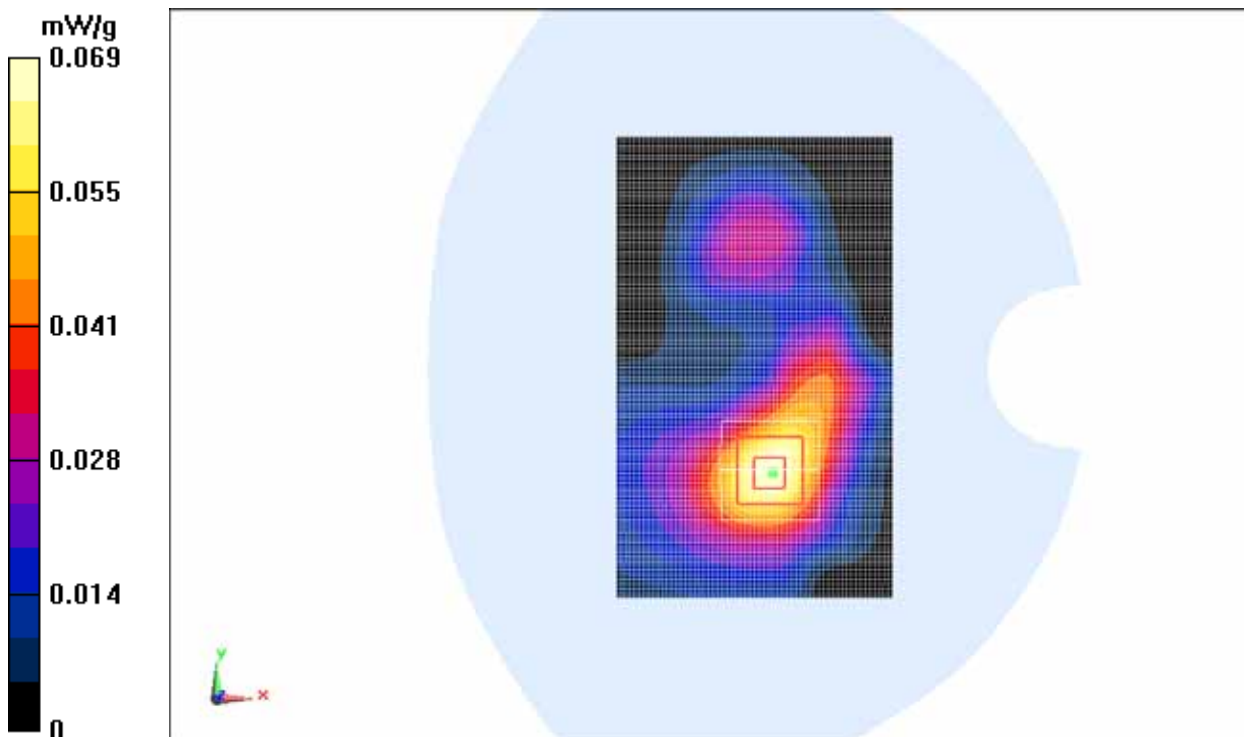

Fig. 45 2450 MHz CH11

Wifi Body Toward Ground High

Date: 2012-2-26

Electronics: DAE4 Sn771

Medium: 2450 Body

Medium parameters used (interpolated): $f = 2462$ MHz; $\sigma = 1.97$ mho/m; $\epsilon_r = 51.8$;
 $\rho = 1000$ kg/m³

Ambient Temperature: 23.3°C Liquid Temperature: 22.5°C

Communication System: Wlan 2450 Frequency: 2462 MHz Duty Cycle: 1:1

Probe: ES3DV3 - SN3149 ConvF(4.13, 4.13, 4.13)

Toward Ground High/Area Scan (61x101x1): Measurement grid: dx=10mm, dy=10mm

Maximum value of SAR (interpolated) = 0.115 mW/g

Toward Ground High/Zoom Scan (7x7x7)/Cube 0: Measurement grid: dx=5mm, dy=5mm, dz=5mm

Reference Value = 4.521 V/m; Power Drift = 0.15 dB

Peak SAR (extrapolated) = 0.1840

SAR(1 g) = 0.107 mW/g; SAR(10 g) = 0.062 mW/g

Maximum value of SAR (measured) = 0.115 mW/g

Toward Ground High/Zoom Scan (7x7x7)/Cube 1: Measurement grid: dx=5mm, dy=5mm, dz=5mm

Reference Value = 4.521 V/m; Power Drift = 0.15 dB

Peak SAR (extrapolated) = 0.1650

SAR(1 g) = 0.088 mW/g; SAR(10 g) = 0.047 mW/g

Maximum value of SAR (measured) = 0.098 mW/g

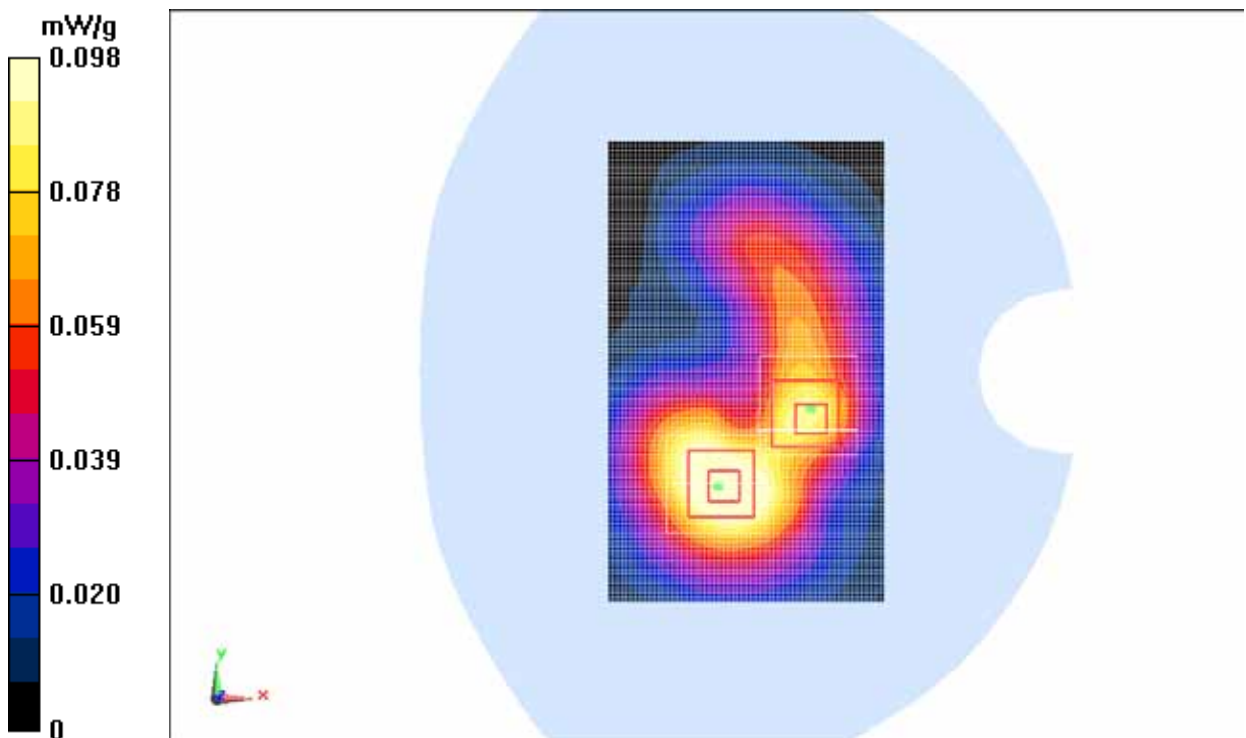

Fig. 46 2450 MHz CH11

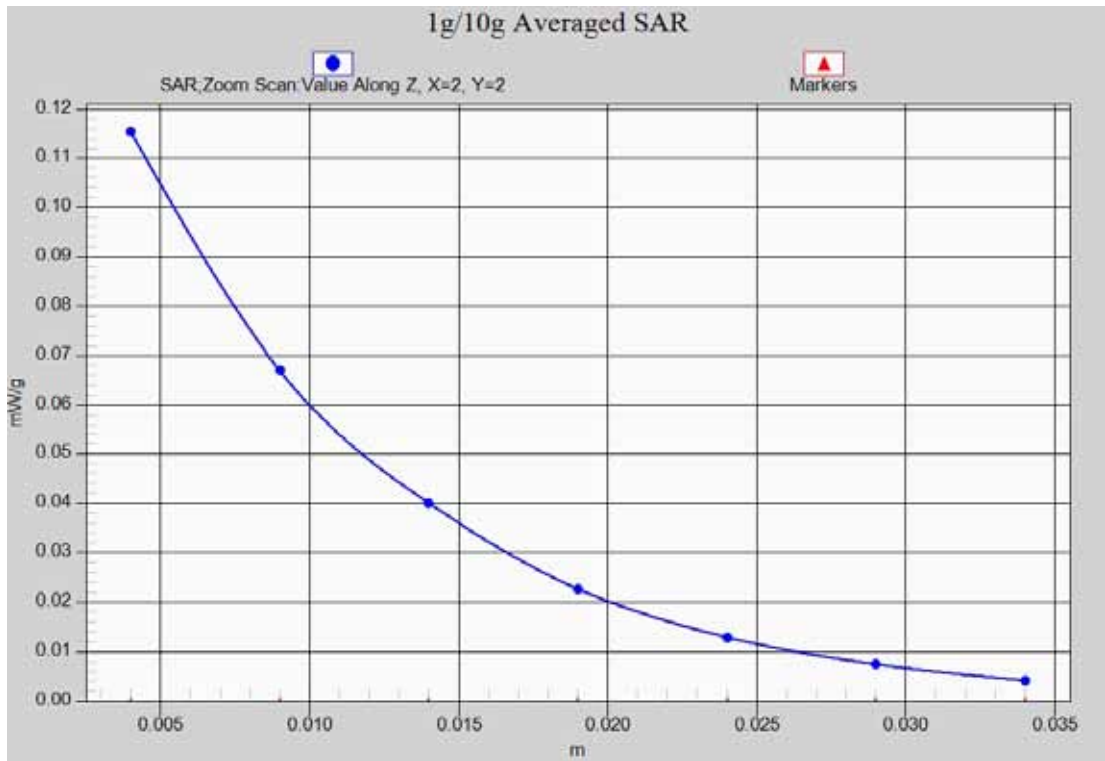

Fig. 46-1 Z-Scan at power reference point (2450 MHz CH11)

ANNEX B SYSTEM VALIDATION RESULTS

835MHz

Date: 2012-2-29

Electronics: DAE4 Sn771

Medium: Head 850 MHz

Medium parameters used: $f = 835 \text{ MHz}$; $\sigma = 0.91 \text{ mho/m}$; $\epsilon_r = 42.5$; $\rho = 1000 \text{ kg/m}^3$

Ambient Temperature: 23.0°C Liquid Temperature: 22.5°C

Communication System: CW Frequency: 835 MHz Duty Cycle: 1:1

Probe: ES3DV3 - SN3149 ConvF(6.56, 6.56, 6.56)

System Validation /Area Scan (101x101x1): Measurement grid: $dx=10\text{mm}$, $dy=10\text{mm}$

Maximum value of SAR (interpolated) = 2.54 mW/g

System Validation /Zoom Scan (7x7x7)/Cube 0: Measurement grid: $dx=5\text{mm}$, $dy=5\text{mm}$, $dz=5\text{mm}$

Reference Value = 54.7 V/m; Power Drift = -0.086 dB

Peak SAR (extrapolated) = 3.33W/kg

SAR(1 g) = 2.29 mW/g; SAR(10 g) = 1.53 mW/g

Maximum value of SAR (measured) = 2.49 mW/g

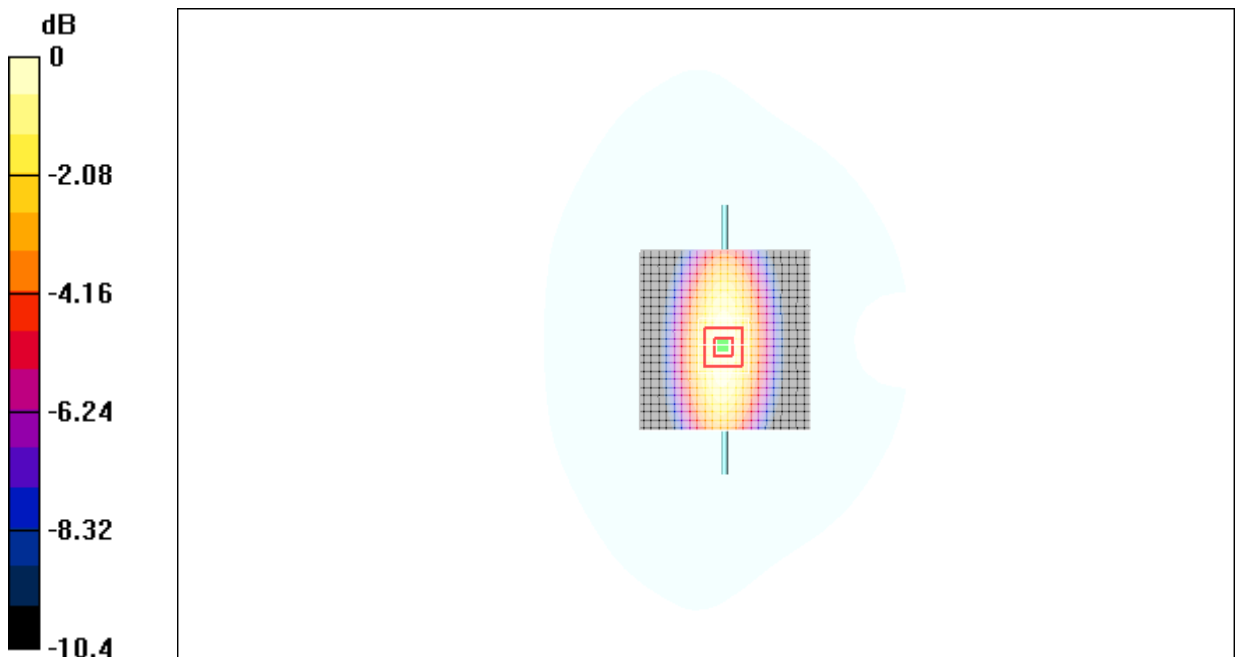

0 dB = 2.49 mW/g

Fig.47 validation 835MHz 250mW

835MHz

Date: 2012-2-29

Electronics: DAE4 Sn771

Medium: Body 850 MHz

Medium parameters used: $f = 835 \text{ MHz}$; $\sigma = 0.97 \text{ mho/m}$; $\epsilon_r = 53.9$; $\rho = 1000 \text{ kg/m}^3$

Ambient Temperature: 23.0°C Liquid Temperature: 22.5°C

Communication System: CW Frequency: 835 MHz Duty Cycle: 1:1

Probe: ES3DV3 - SN3149 ConvF(6.22, 6.22, 6.22)

System Validation /Area Scan (101x101x1): Measurement grid: $dx=10\text{mm}$, $dy=10\text{mm}$

Maximum value of SAR (interpolated) = 2.50 mW/g

System Validation /Zoom Scan (7x7x7)/Cube 0: Measurement grid: $dx=5\text{mm}$, $dy=5\text{mm}$, $dz=5\text{mm}$

Reference Value = 50.3 V/m; Power Drift = -0.118 dB

Peak SAR (extrapolated) = 3.31 W/kg

SAR(1 g) = 2.32 mW/g; SAR(10 g) = 1.51 mW/g

Maximum value of SAR (measured) = 2.42 mW/g

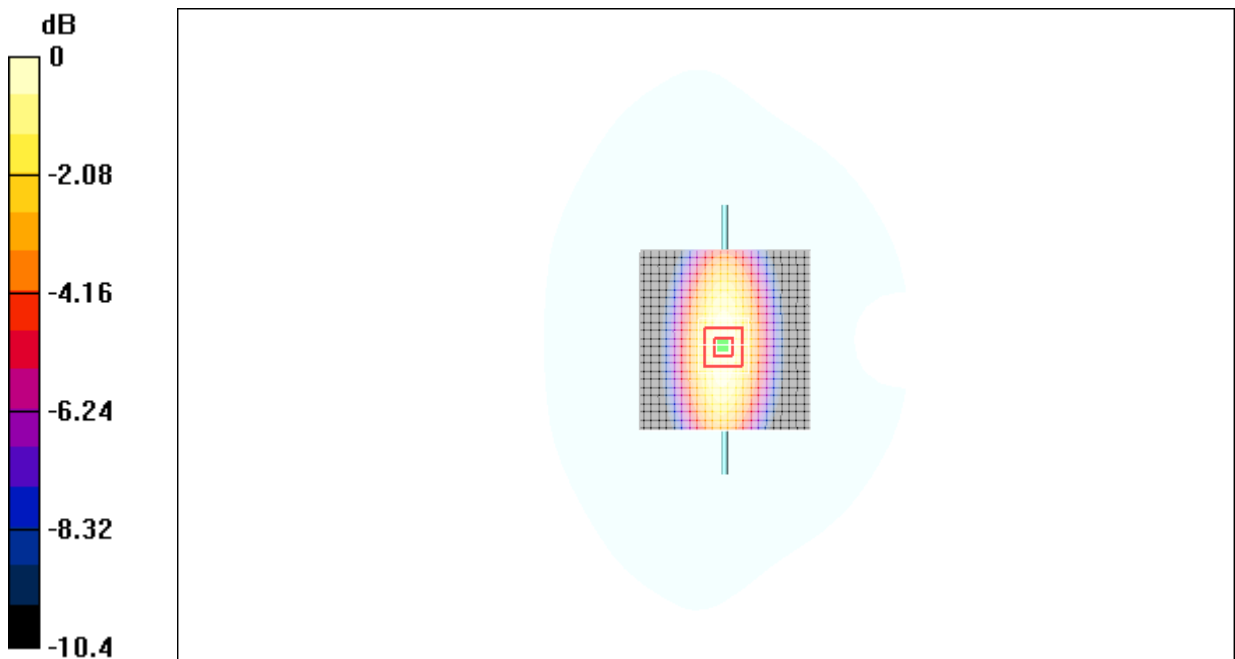

0 dB = 2.42 mW/g

Fig.48 validation 835MHz 250mW

1900MHz

Date: 2012-3-1

Electronics: DAE4 Sn771

Medium: Head 1900 MHz

Medium parameters used: $f = 1900$ MHz; $\sigma = 1.39$ mho/m; $\epsilon_r = 40.9$; $\rho = 1000$ kg/m³

Ambient Temperature: 23.0°C Liquid Temperature: 22.5°C

Communication System: CW Frequency: 1900 MHz Duty Cycle: 1:1

Probe: ES3DV3 - SN3149 ConvF(5.03, 5.03, 5.03)

System Validation/Area Scan (101x101x1): Measurement grid: dx=10mm, dy=10mm

Maximum value of SAR (interpolated) = 11.4 mW/g

System Validation/Zoom Scan (7x7x7)/Cube 0: Measurement grid: dx=5mm, dy=5mm, dz=5mm

Reference Value = 89.2 V/m; Power Drift = -0.069 dB

Peak SAR (extrapolated) = 14.5 W/kg

SAR(1 g) = 9.68mW/g; SAR(10 g) = 4.99 mW/g

Maximum value of SAR (measured) = 10.4mW/g

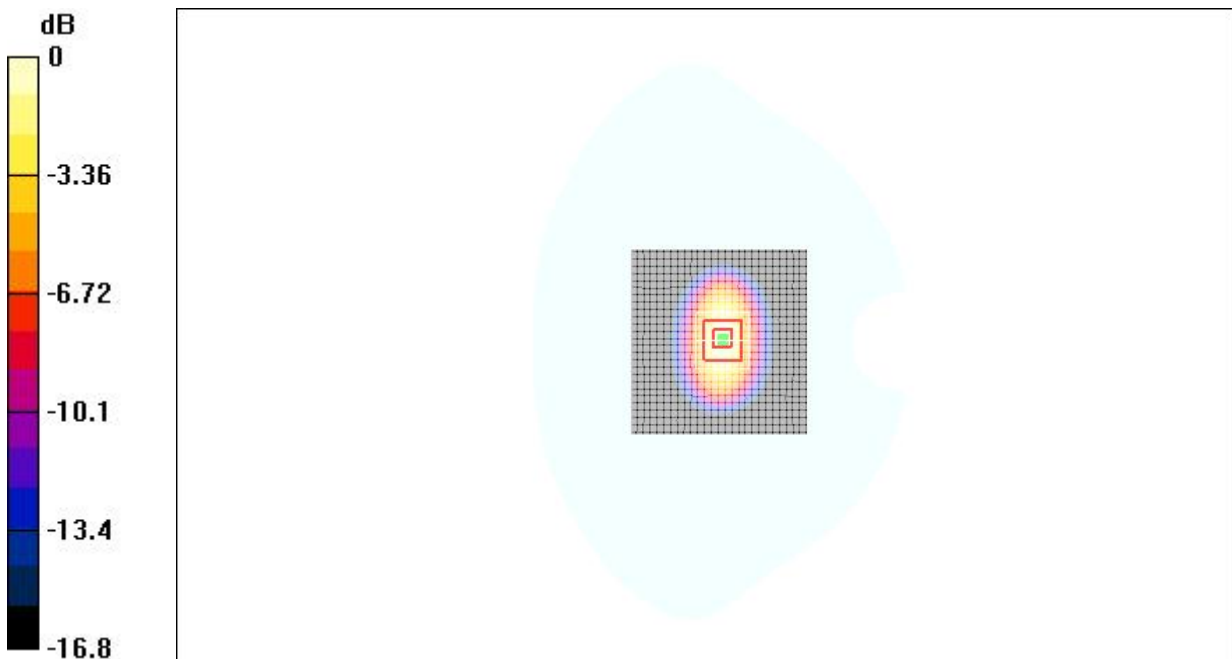

0 dB = 10.4 mW/g

Fig.49 validation 1900MHz 250mW

1900MHz

Date: 2012-3-1

Electronics: DAE4 Sn771

Medium: Body 1900 MHz

Medium parameters used: $f = 1900$ MHz; $\sigma = 1.50$ mho/m; $\epsilon_r = 53.1$; $\rho = 1000$ kg/m³

Ambient Temperature: 23.0°C Liquid Temperature: 22.5°C

Communication System: CW Frequency: 1900 MHz Duty Cycle: 1:1

Probe: ES3DV3 - SN3149 ConvF(4.68, 4.68, 4.68)

System Validation/Area Scan (101x101x1): Measurement grid: dx=10mm, dy=10mm

Maximum value of SAR (interpolated) = 11.5 mW/g

System Validation/Zoom Scan (7x7x7)/Cube 0: Measurement grid: dx=5mm, dy=5mm, dz=5mm

Reference Value = 92.8 V/m; Power Drift = 0.070 dB

Peak SAR (extrapolated) = 15.6 W/kg

SAR(1 g) = 10.2 mW/g; SAR(10 g) = 5.11 mW/g

Maximum value of SAR (measured) = 11.0 mW/g

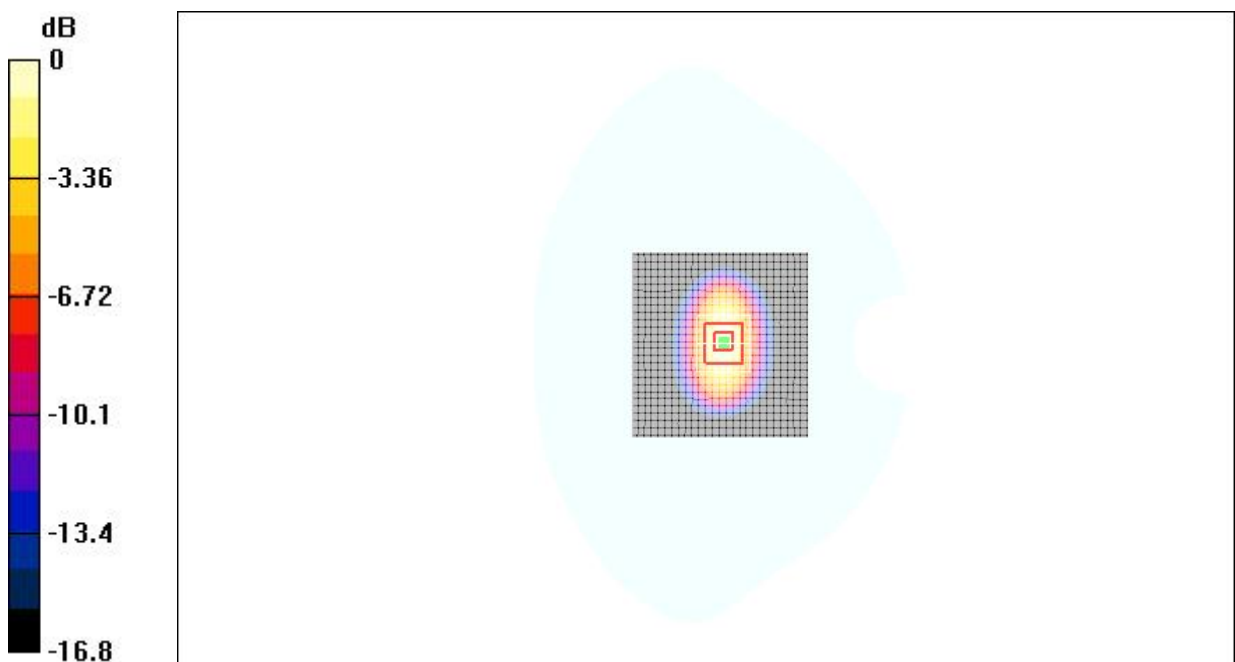

0 dB = 11.0 mW/g

Fig.50 validation 1900MHz 250mW

2450MHz

Date: 2012-2-26

Electronics: DAE4 Sn771

Medium: Head 2450

Medium parameters used: $f = 2450 \text{ MHz}$; $\sigma = 1.82 \text{ mho/m}$; $\epsilon_r = 38.5$; $\rho = 1000 \text{ kg/m}^3$

Ambient Temperature: 23.0°C Liquid Temperature: 22.5°C

Communication System: CW Frequency: 2450 MHz Duty Cycle: 1:1

Probe: ES3DV3 - SN3149 ConvF(4.35, 4.35, 4.35)

System Validation/Area Scan (101x101x1): Measurement grid: $dx=10\text{mm}$, $dy=10\text{mm}$

Maximum value of SAR (interpolated) = 14.1 mW/g

System Validation/Zoom Scan (7x7x7)/Cube 0: Measurement grid: $dx=5\text{mm}$, $dy=5\text{mm}$, $dz=5\text{mm}$

Reference Value = 87.3 V/m ; Power Drift = 0.058 dB

Peak SAR (extrapolated) = 18.4 W/kg

SAR(1 g) = 12.9 mW/g ; SAR(10 g) = 5.98 mW/g

Maximum value of SAR (measured) = 13.6 mW/g

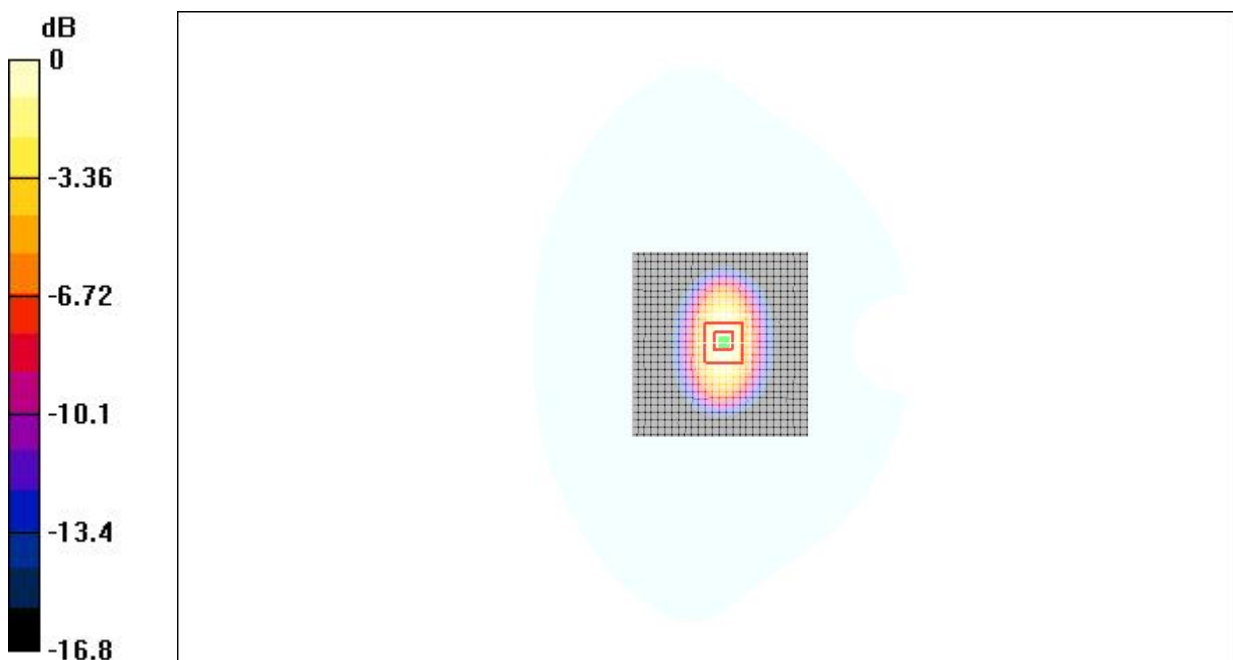

0 dB = 13.6 mW/g

Fig.51 validation 2450MHz 250mW

2450MHz

Date: 2012-2-26

Electronics: DAE4 Sn771

Medium: Body 2450

Medium parameters used: $f = 2450 \text{ MHz}$; $\sigma = 1.96 \text{ mho/m}$; $\epsilon_r = 51.9$; $\rho = 1000 \text{ kg/m}^3$

Ambient Temperature: 23.0oC Liquid Temperature: 22.5°C

Communication System: CW Frequency: 2450 MHz Duty Cycle: 1:1

Probe: ES3DV3 - SN3149 ConvF(4.13, 4.13, 4.13)

System Validation/Area Scan (101x101x1): Measurement grid: dx=10mm, dy=10mm

Maximum value of SAR (interpolated) = 15.6 mW/g

System Validation/Zoom Scan (7x7x7)/Cube 0: Measurement grid: dx=5mm, dy=5mm, dz=5mm

Reference Value = 81.0 V/m; Power Drift = 0.067 dB

Peak SAR (extrapolated) = 24.0 W/kg

SAR(1 g) = 12.8 mW/g; SAR(10 g) = 5.80 mW/g

Maximum value of SAR (measured) = 14.4 mW/g

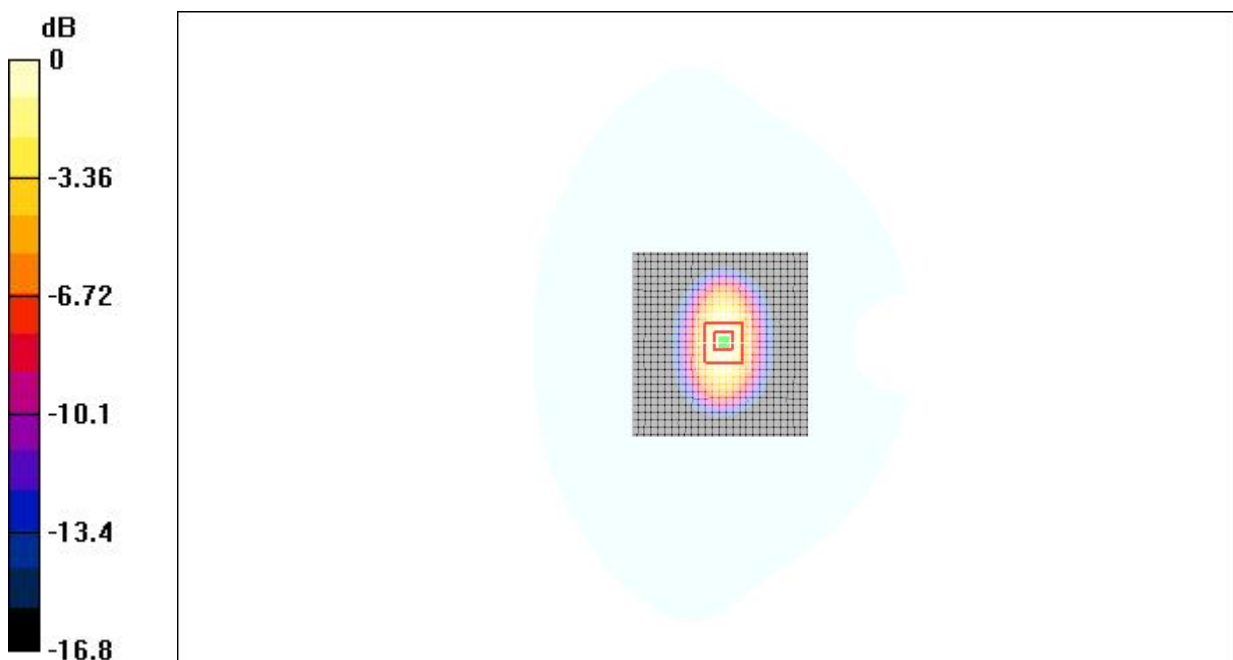

0 dB = 14.4 mW/g

Fig.52 validation 2450MHz 250mW

ANNEX C DIPOLE CALIBRATION CERTIFICATE

**Calibration Laboratory of
Schmid & Partner
Engineering AG**
Zeughausstrasse 43, 8004 Zurich, Switzerland



S Schweizerischer Kalibrierdienst
C Service suisse d'étalonnage
S Servizio svizzero di taratura
S Swiss Calibration Service

Accredited by the Swiss Accreditation Service (SAS)
The Swiss Accreditation Service is one of the signatories to the EA
Multilateral Agreement for the recognition of calibration certificates

Accreditation No.: **SCS 108**

Client **TMC China**

Certificate No: **ES3DV3-3149_Sep11**

CALIBRATION CERTIFICATE

Object	ES3DV3-SN: 3149
Calibration procedure(s)	QA CAL-01.v6 Calibration procedure for dosimetric E-field probes
Calibration date:	September 24, 2011
Condition of the calibrated item	In Tolerance

This calibration certify documents the traceability to national standards, which realize the physical units of measurements(SI).
The measurements and the uncertainties with confidence probability are given on the following pages and are part of the certificate.
All calibrations have been conducted at an environment temperature (22±3)⁰C and humidity<70%

Calibration Equipment used (M&TE critical for calibration)

Primary Standards	ID#	Cal Data (Calibrated by, Certification NO.)	Scheduled Calibration
Power meter E4419B	GB41293874	5-May-11 (METAS, NO. 251-00388)	May-12
Power sensor E4412A	MY41495277	5-May-11 (METAS, NO. 251-00388)	May-12
Reference 3 dB Attenuator	SN:S5054 (3c)	11-Aug-11 (METAS, NO. 251-00403)	Aug-12
Reference 20 dB Attenuator	SN:S5086 (20b)	3-May-11 (METAS, NO. 251-00389)	May-12
Reference 30 dB Attenuator	SN:S5129 (30b)	11-Aug-11 (METAS, NO. 251-00404)	Aug-12
DAE4	SN:617	10-Jun-11 (SPEAG, NO.DAE4-907_Jun11)	Jun-12
Reference Probe ES3DV2	SN: 3013	12-Jan-11 (SPEAG, NO. ES3-3013_Jan11)	Jan-12

Secondary Standards	ID#	Check Data (in house)	Scheduled Calibration
RF generator HP8648C	US3642U01700	4-Aug-99(SPEAG, in house check Oct-10)	In house check: Oct-11
Network Analyzer HP 8753E	US37390585	18-Oct-01(SPEAG, in house check Nov-10)	In house check: Nov-11

Name	Function	Signature
Calibrated by: Katja Pokovic	Technical Manager	

Approved by: Niels Kuster	Quality Manager	
---------------------------	-----------------	--

Issued: **September 24, 2011**

This calibration certificate shall not be reported except in full without written approval of the laboratory.

Calibration Laboratory of
Schmid & Partner
Engineering AG
Zeughausstrasse 43, 8004 Zurich, Switzerland



S Schweizerischer Kalibrierdienst
S Service suisse d'étalonnage
C Servizio svizzero di taratura
S Swiss Calibration Service

Accredited by the Swiss Accreditation Service (SAS)
The Swiss Accreditation Service is one of the signatories to the EA
Multilateral Agreement for the recognition of calibration certificates

Accreditation No.: SCS 108

Glossary:

TSL	tissue simulating liquid
NORM _{x,y,z}	sensitivity in free space
ConF	sensitivity in TSL / NORM _{x,y,z}
DCP	diode compression point
Polarization φ	φ rotation around probe axis
Polarization ϑ	ϑ rotation around an axis that is in the plane normal to probe axis (at measurement center), i.e., $\vartheta = 0$ is normal to probe axis

Calibration is Performed According to the Following Standards:

- a) IEEE Std 1528-2003, "IEEE Recommended Practice for Determining the Peak Spatial-Averaged Specific Absorption Rate (SAR) in the Human Head from Wireless Communications Devices: Measurement Techniques", December 2003
- b) IEC 62209-1, "Procedure to measure the Specific Absorption Rate (SAR) for hand-held devices used in close proximity to the ear (frequency range of 300 MHz to 3 GHz)", February 2005

Methods Applied and Interpretation of Parameters:

- *NORM_{x,y,z}*: Assessed for E-field polarization $\vartheta = 0$ ($f \leq 900$ MHz in TEM-cell; $f > 1800$ MHz: R22 waveguide). *NORM_{x,y,z}* are only intermediate values, i.e., the uncertainties of *NORM_{x,y,z}* does not effect the E^2 -field uncertainty inside TSL (see below *ConvF*).
- *NORM(f)_{x,y,z}* = *NORM_{x,y,z}* * *frequency_response* (see Frequency Response Chart). This linearization is implemented in DASY4 software versions later than 4.2. The uncertainty of the frequency response is included in the stated uncertainty of *ConvF*.
- *DCP_{x,y,z}*: DCP are numerical linearization parameters assessed based on the data of power sweep (no uncertainty required). DCP does not depend on frequency nor media.
- *ConvF and Boundary Effect Parameters*: Assessed in flat phantom using E-field (or Temperature Transfer Standard for $f \leq 800$ MHz) and inside waveguide using analytical field distributions based on power measurements for $f > 800$ MHz. The same setups are used for assessment of the parameters applied for boundary compensation (alpha, depth) of which typical uncertainty values are given. These parameters are used in DASY4 software to improve probe accuracy close to the boundary. The sensitivity in TSL corresponds to *NORM_{x,y,z}* * *ConvF* whereby the uncertainty corresponds to that given for *ConvF*. A frequency dependent *ConvF* is used in DASY version 4.4 and higher which allows extending the validity from ± 50 MHz to ± 100 MHz.
- *Spherical isotropy (3D deviation from isotropy)*: in a field of low gradients realized using a flat phantom exposed by a patch antenna.
- *Sensor Offset*: The sensor offset corresponds to the offset of virtual measurement center from the probe tip (on probe axis). No tolerance required.

ES3DV3 SN: 3149

September 24, 2011

Probe ES3DV3

SN: 3149

Manufactured: June 12, 2007

Calibrated: September 24, 2011

Calibrated for DASY/EASY System

(Note: non-compatible with DASY2 system!)

ES3DV3 SN: 3149

September 24, 2011

DASY/EASY – Parameters of Probe: ES3DV3 - SN:3149

Basic Calibration Parameters

	Sensor X	Sensor Y	Sensor Z	Unc (k=2)
Norm ($\mu V/(V/m)^2$) ^A	1.14	1.23	1.29	$\pm 10.1\%$
DCP (mV) ^B	94	95	91	

Modulation Calibration Parameters

UID	Communication System Name	PAR		A dB	B dBuV	C	VR mV	Unc ^E (k=2)
10000	CW	0.00	X	0.00	0.00	1.00	300.0	$\pm 1.5\%$
			Y	0.00	0.00	1.00	300.0	
			Z	0.00	0.00	1.00	300.0	

The reported uncertainty of measurement is stated as the standard uncertainty of measurement multiplied by the coverage factor $k=2$, which for a normal distribution corresponds to a coverage probability of approximately 95%.

^A The uncertainties of NormX, Y, Z do not affect the E^2 -field uncertainty inside TSL (see Page 5 and 6).

^B Numerical linearization parameter: uncertainty not required.

^E Uncertainty is determined using the maximum deviation from linear response applying rectangular distribution and is expressed for the square of the field value.

ES3DV3 SN: 3149

September 24, 2011

DASY/EASY – Parameters of Probe: ES3DV3 - SN:3149

Calibration Parameter Determined in Head Tissue Simulating Media

f[MHz] ^C	Relative Permittivity ^F	Conductivity (S/m) ^F	ConvF X	ConvF Y	ConvF Z	Alpha	Depth (mm)	Unct. (k=2)
850	41.5	0.90	6.56	6.56	6.56	0.91	1.13	±12.0%
900	41.5	0.97	6.34	6.34	6.34	0.83	1.26	±12.0%
1800	40.0	1.40	5.18	5.18	5.18	0.69	1.47	±12.0%
1900	40.0	1.40	5.03	5.03	5.03	0.72	1.38	±12.0%
2100	39.8	1.49	4.58	4.58	4.58	0.66	1.34	±12.0%
2450	39.2	1.80	4.35	4.35	4.35	0.67	1.36	±12.0%

^C Frequency validity of ±100 MHz only applies for DASY v4.4 and higher (see Page 2), else it is restricted to ±50 MHz. The uncertainty is the RSS of the ConvF uncertainty at calibration frequency and the uncertainty for the indicated frequency band.

^F At frequencies below 3 GHz, the validity of tissue parameters (ϵ and σ) can be relaxed to ±10% if liquid compensation formula is applied to measured SAR values. At frequencies above 3 GHz, the validity of tissue parameters (ϵ and σ) is restricted to ±5%. The uncertainty is the RSS of the ConvF uncertainty for indicated target tissue parameters.

ES3DV3 SN: 3149

September 24, 2011

DASY/EASY – Parameters of Probe: ES3DV3 - SN:3149

Calibration Parameter Determined in Body Tissue Simulating Media

f[MHz] ^C	Relative Permittivity ^F	Conductivity (S/m) ^F	ConvF X	ConvF Y	ConvF Z	Alpha	Depth (mm)	Unct. (k=2)
850	55.2	0.97	6.22	6.22	6.22	0.76	1.26	±12.0%
900	55.0	1.05	6.02	6.02	6.02	0.99	1.06	±12.0%
1800	53.3	1.52	4.97	4.97	4.97	0.75	1.34	±12.0%
1900	53.3	1.52	4.68	4.68	4.68	0.62	1.33	±12.0%
2100	53.5	1.57	4.35	4.35	4.35	0.68	1.34	±12.0%
2450	52.7	1.95	4.13	4.13	4.13	0.71	1.35	±12.0%

^C Frequency validity of ±100 MHz only applies for DASY v4.4 and higher (see Page 2), else it is restricted to ±50 MHz. The uncertainty is the RSS of the ConvF uncertainty at calibration frequency and the uncertainty for the indicated frequency band.

^F At frequencies below 3 GHz, the validity of tissue parameters (ϵ and σ) can be relaxed to ±10% if liquid compensation formula is applied to measured SAR values. At frequencies above 3 GHz, the validity of tissue parameters (ϵ and σ) is restricted to ±5%. The uncertainty is the RSS of the ConvF uncertainty for indicated target tissue parameters.

ES3DV3 SN: 3149

September 24, 2011

Frequency Response of E-Field (TEM-Cell: ifi110 EXX, Waveguide: R22)

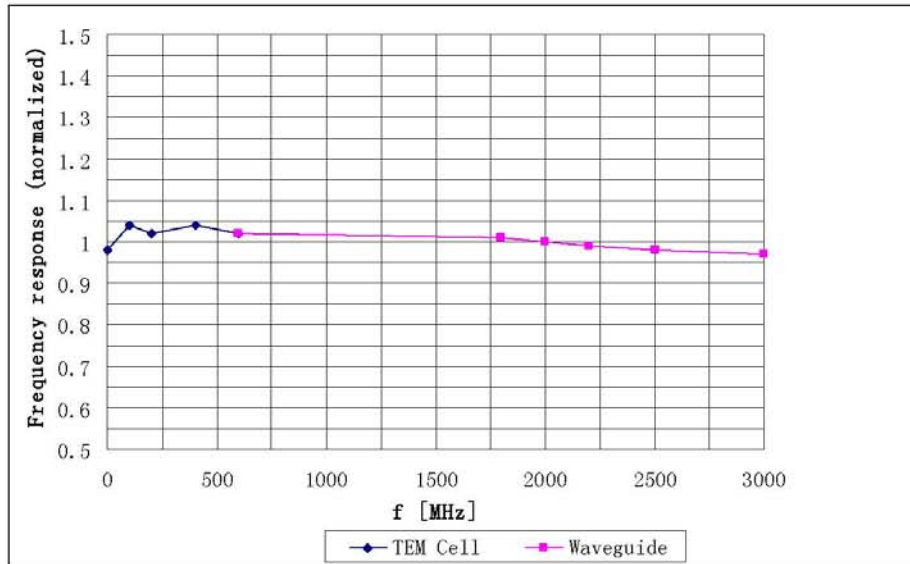

Uncertainty of Frequency Response of E-field: $\pm 5.0\%$ (k=2)

ES3DV3 SN: 3149

September 24, 2011

Receiving Pattern (ϕ), $\theta = 0^\circ$

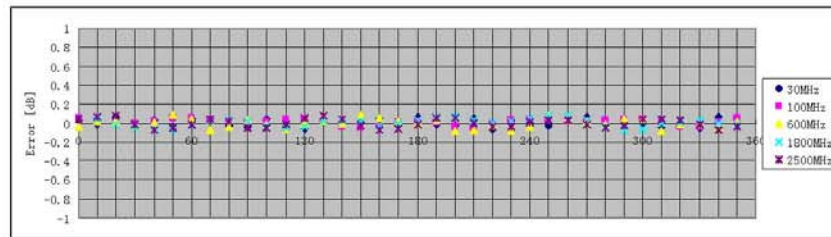
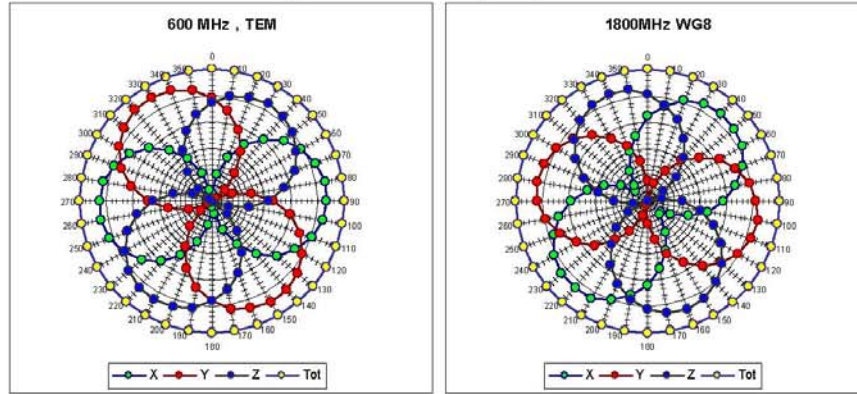

Uncertainty of Axial Isotropy Assessment: $\pm 0.5\%$ ($k=2$)

ES3DV3 SN: 3149

September 24, 2011

Dynamic Range $f(\text{SAR}_{\text{head}})$ (Waveguide: WG8, $f = 1800 \text{ MHz}$)

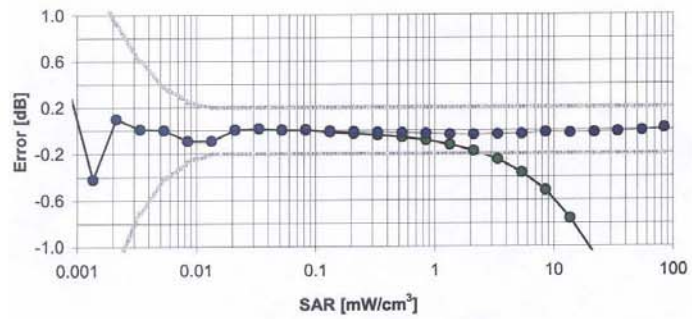
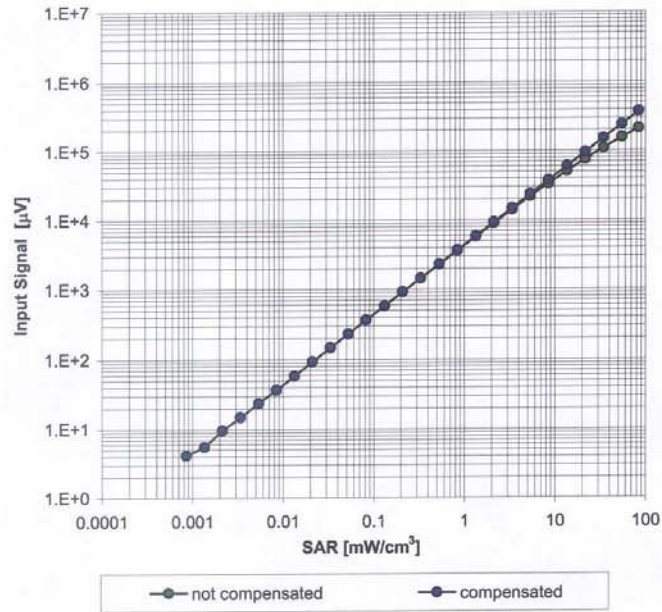

Uncertainty of Linearity Assessment: $\pm 0.5\%$ ($k=2$)

ES3DV3 SN: 3149

September 24, 2011

Conversion Factor Assessment

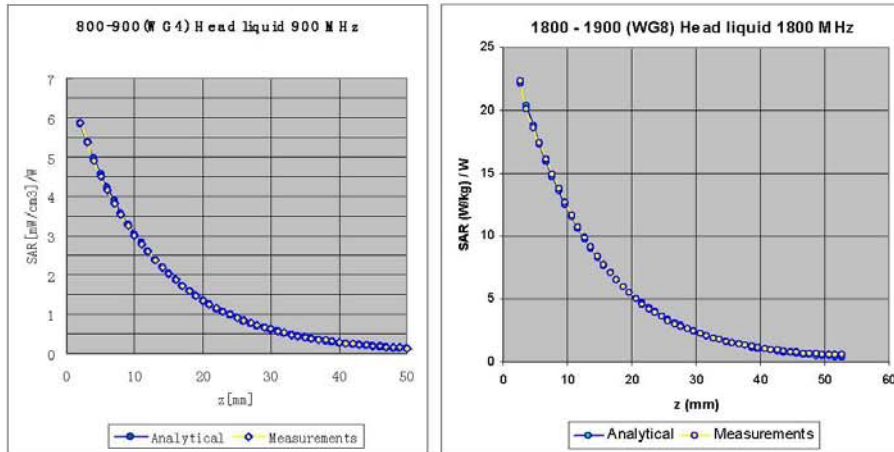

Deviation from Isotropy

Error (ϕ, θ), $f = 900$ MHz

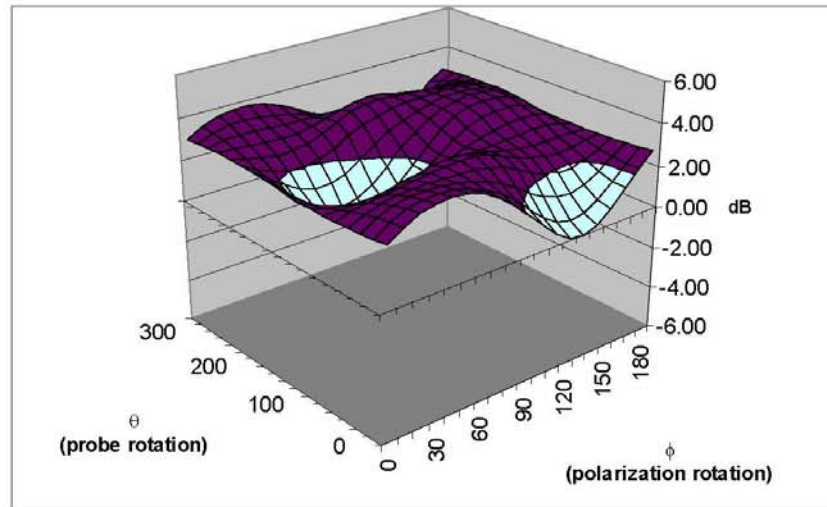

Uncertainty of Spherical Isotropy Assessment: $\pm 2.5\%$ ($k=2$)

ES3DV3 SN: 3149

September 24, 2011

DASY/EASY – Parameters of Probe: ES3DV3 - SN:3149**Other Probe Parameters**

Sensor Arrangement	Triangular
Connector Angle (°)	Not applicable
Mechanical Surface Detection Mode	enabled
Optical Surface Detection Mode	disabled
Probe Overall Length	337 mm
Probe Body Diameter	10 mm
Tip Length	10 mm
Tip Diameter	4 mm
Probe Tip to Sensor X Calibration Point	2 mm
Probe Tip to Sensor Y Calibration Point	2 mm
Probe Tip to Sensor Z Calibration Point	2 mm
Recommended Measurement Distance from Surface	2 mm

ANNEX D DIPOLE CALIBRATION CERTIFICATE

835 MHz Dipole Calibration Certificate

工业和信息化部通信计量中心
Telecommunication Metrology Center of MIIT







校准
CNAS L0442

Client **TMC** Certificate No: **D835V2-443_Feb10**

CALIBRATION CERTIFICATE

Object	D835V2 - SN: 443
Calibration Procedure(s)	TMC-XZ-01-027 Calibration procedure for dipole validation kits
Calibration date:	February 26, 2010
Condition of the calibrated item	In Tolerance

This calibration Certificate documents the traceability to national standards, which realize the physical units of measurements(SI). The measurements and the uncertainties with confidence probability are given on the following pages and are part of the certificate.

All calibrations have been conducted in the closed laboratory facility: environment temperature(22±3)°C and humidity<70%.

Calibration Equipment used (M&TE critical for calibration)

Primary Standards	ID #	Cal Date(Calibrated by, Certificate No.)	Scheduled Calibration
Power Meter NRVD	101253	04-Sep-09 (TMC, No.JZ09-248)	Jun-10
Power sensor NRV-Z5	100333	04-Sep-09 (TMC, No. JZ09-248)	Jun-10
Reference Probe ES3DV3	SN 3149	25-Sep-09(SPEAG, No.ES3-3149_Sep09)	Sep-10
DAE4	SN 771	19-Nov-09(SPEAG, No.DAE4-771_Nov09)	Nov-10
RF generator E4438C	MY45092879	18-Jun-09(TMC, No.JZ09-302)	Jun-10
Network Analyzer 8753E	US38433212	29-Aug-09(TMC, No.JZ09-056)	Aug-10

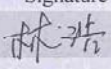
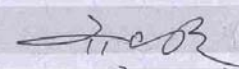
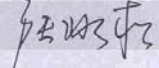
	Name	Function	Signature
Calibrated by:	Lin Hao	SAR Test Engineer	
Reviewed by:	Qi Dianyuan	SAR Project Leader	
Approved by:	Lu Bingsong	Deputy Director of the laboratory	

Issued: February 26, 2010

This calibration certificate shall not be reproduced except in full without written approval of the laboratory.

Certificate No: D835V2-443_Feb10

Page 1 of 9

工业和信息化部通信计量中心
Telecommunication Metrology Center of MIIT



Glossary:

TSL	tissue simulating liquid
ConvF	sensitivity in TSL / NORM _{x,y,z}
N/A	not applicable or not measured

Calibration is Performed According to the Following Standards:

- a) IEEE Std 1528-2003, "IEEE Recommended Practice for Determining the Peak Spatial-Averaged Specific Absorption Rate (SAR) in the Human Head from Wireless Communications Devices: Measurement Techniques", December 2003
- b) IEC 62209-1, "Procedure to measure the Specific Absorption Rate (SAR) For hand-held devices used in close proximity to the ear (frequency range of 300MHz to 3GHz)", February 2005
- c) Federal Communications Commission Office of Engineering & Technology (FCC OET), "Evaluating Compliance with FCC Guidelines for Human Exposure to Radiofrequency Electromagnetic Fields; Additional Information for Evaluating Compliance of Mobile and Portable Devices with FCC Limits for Human Exposure to Radiofrequency Emissions", Supplement C (Edition 01-01) to Bulletin 65

Additional Documentation:

- d) DASY System Handbook

Methods Applied and Interpretation of Parameters:

- Measurement Conditions: Further details are available from the Validation Report at the end of the certificate. All figures stated in the certificate are valid at the frequency indicated.
- Antenna Parameters with TSL: The dipole is mounted with the spacer to position its feed point exactly below the center marking of the flat phantom section, with the arms oriented parallel to the body axis.
- Feed Point Impedance and Return Loss: These parameters are measured with the dipole positioned under the liquid filled phantom. The impedance stated is transformed from the measurement at the SMA connector to the feed point. The Return Loss ensures low reflected power. No uncertainty required.
- Electrical Delay: One-way delay between the SMA connector and the antenna feed point. No uncertainty required.
- SAR measured: SAR measured at the stated antenna input power.
- SAR normalized: SAR as measured, normalized to an input power of 1 W at the antenna connector.
- SAR for nominal TSL parameters: The measured TSL parameters are used to calculate the nominal SAR result.

Measurement Conditions

DASY system configuration, as far as not given on page 1.

DASY Version	DASY5	V5.0
Extrapolation	Advanced Extrapolation	
Phantom	2mm Oval Phantom ELI4	
Distance Dipole Center - TSL	15 mm	with Spacer
Zoom Scan Resolution	dx, dy, dz = 5 mm	
Frequency	835 MHz \pm 1 MHz	

Head TSL parameters

The following parameters and calculations were applied.

	Temperature	Permittivity	Conductivity
Nominal Head TSL parameters	22.0 °C	41.5	0.90 mho/m
Measured Head TSL parameters	(22.0 \pm 0.2) °C	41.6 \pm 6 %	0.92mho/m \pm 6 %
Head TSL temperature during test	(21.7 \pm 0.2) °C	----	----

SAR result with Head TSL

SAR averaged over 1 cm^3 (1 g) of Head TSL	Condition	
SAR measured	250 mW input power	2.38 mW / g
SAR normalized	normalized to 1W	9.52 mW / g
SAR for nominal Head TSL parameters ¹	normalized to 1W	9.41 mW / g \pm 17.0 % (k=2)

SAR averaged over 10 cm^3 (10 g) of Head TSL	Condition	
SAR measured	250 mW input power	1.54 mW / g
SAR normalized	normalized to 1W	6.16 mW / g
SAR for nominal Head TSL parameters ¹	normalized to 1W	6.12 mW / g \pm 16.5 % (k=2)

¹ Correction to nominal TSL parameters according to d), chapter "SAR Sensitivities"

Body TSL parameters

The following parameters and calculations were applied.

	Temperature	Permittivity	Conductivity
Nominal Body TSL parameters	22.0 °C	55.2	0.97 mho/m
Measured Body TSL parameters	(22.0 ± 0.2) °C	54.5 ± 6%	0.97mho/m ± 6 %
Body TSL temperature during test	(21.9 ± 0.2) °C	----	----

SAR result with Body TSL

SAR averaged over 1 cm^3 (1 g) of Body TSL	Condition	
SAR measured	250 mW input power	2.41 mW / g
SAR normalized	normalized to 1W	9.64 mW / g
SAR for nominal Body TSL parameters ²	normalized to 1W	9.57 mW / g ± 17.0 % (k=2)

SAR averaged over 10 cm^3 (10 g) of Body TSL	Condition	
SAR measured	250 mW input power	1.57 mW / g
SAR normalized	normalized to 1W	6.28 mW / g
SAR for nominal Body TSL parameters ²	normalized to 1W	6.24 mW / g ± 16.5 % (k=2)

² Correction to nominal TSL parameters according to d), chapter "SAR Sensitivities"

工业和信息化部通信计量中心
Telecommunication Metrology Center of MIIT



Appendix

Antenna Parameters with Head TSL

Impedance, transformed to feed point	53.7Ω - 3.7 jΩ
Return Loss	- 25.9dB

Antenna Parameters with Body TSL

Impedance, transformed to feed point	49.4Ω - 5.1 jΩ
Return Loss	-25.6dB

General Antenna Parameters and Design

Electrical Delay (one direction)	1.387 ns
----------------------------------	----------

After long term use with 100W radiated power, only a slight warming of the dipole near the feedpoint can be measured.

The dipole is made of standard semirigid coaxial cable. The center conductor of the feeding line is directly connected to the second arm of the dipole. The antenna is therefore short-circuited for DC-signals.
No excessive force must be applied to the dipole arms, because they might bend or the soldered connections near the feedpoint may be damaged.

Additional EUT Data

Manufactured by	SPEAG
Manufactured on	September 3, 2001

工业和信息化部通信计量中心
Telecommunication Metrology Center of MIIT



DASY5 Validation Report for Head TSL

Date/Time: 2010-2-26 14:31:40

Test Laboratory: TMC, Beijing, China

DUT: Dipole 835 MHz; Type: D835V2; Serial: SN: 443

Communication System: CW Frequency: 835 MHz Duty Cycle: 1:1

Medium: Head 835MHz

Medium parameters used: $f = 835 \text{ MHz}$; $\sigma = 0.92 \text{ mho/m}$; $\epsilon_r = 41.6$; $\rho = 1000 \text{ kg/m}^3$

Phantom section: Flat Section

DASY5 Configuration:

- Probe: ES3DV3 - SN3149; ConvF(6.56, 6.56, 6.56); Calibrated: 25.09.09
- Electronics: DAE4 Sn771; Calibration: 19.11.09
- Phantom: 2mm Oval Phantom ELI4; Type: QDOVA001BB
- Measurement SW: DASY5, V5.0 Build 119.9; Postprocessing SW: SEMCAD, V13.2 Build 87

Pin=250mW; d=15mm/Zoom Scan (7x7x7)/Cube 0:

Measurement grid: dx=5mm, dy=5mm, dz=5mm

Reference Value = 54.8 V/m; Power Drift = -0.037 dB

Peak SAR (extrapolated) = 3.11 W/kg

SAR(1 g) = 2.38 mW/g; SAR(10 g) = 1.54 mW/g

Maximum value of SAR (measured) = 2.71 mW/g

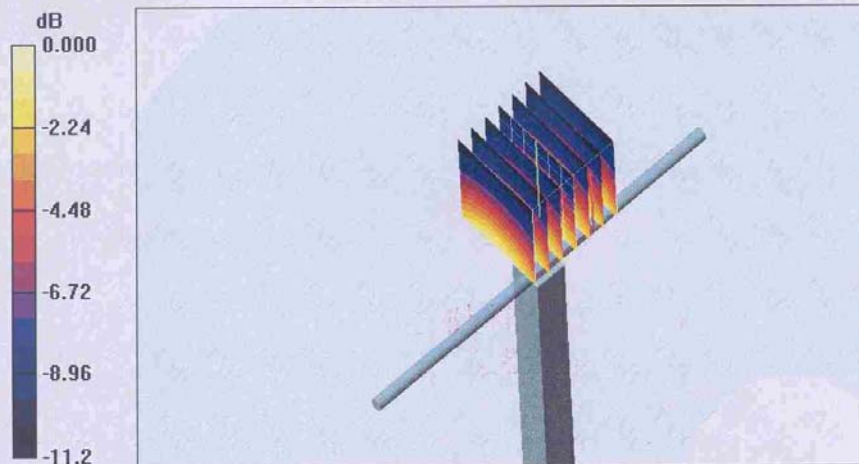

0 dB = 2.71mW/g

工业和信息化部通信计量中心
Telecommunication Metrology Center of MIIT



Impedance Measurement Plot for Head TSL

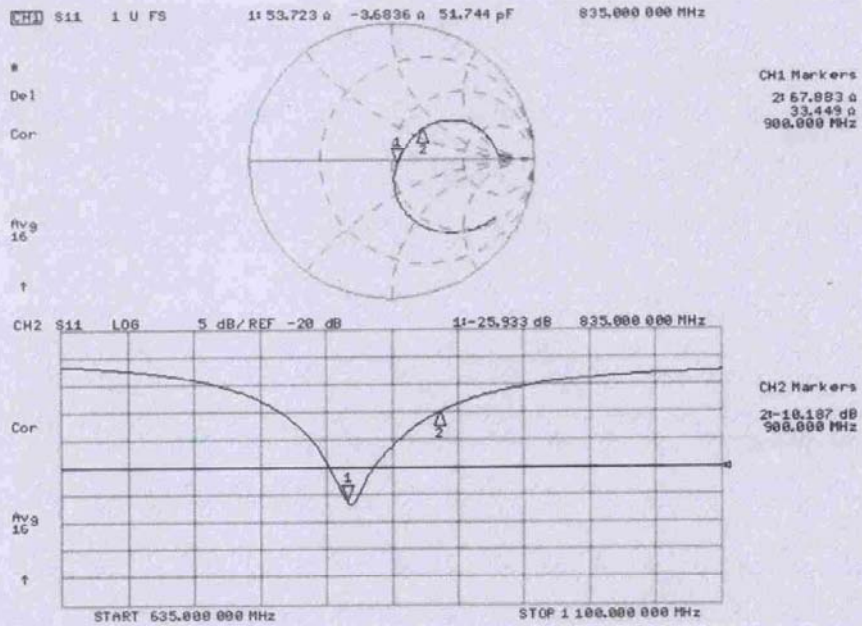

工业和信息化部通信计量中心
Telecommunication Metrology Center of MIIT



DASY5 Validation Report for Body TSL

Date/Time: 2010-2-26 9:52:36

Test Laboratory: TMC, Beijing, China

DUT: Dipole 835 MHz; Type: D835V2; Serial: SN: 443

Communication System: CW Frequency: 835 MHz Duty Cycle: 1:1

Medium: Body 835MHz

Medium parameters used: $f = 835 \text{ MHz}$; $\sigma = 0.97 \text{ mho/m}$; $\epsilon_r = 54.5$; $\rho = 1000 \text{ kg/m}^3$

Phantom section: Flat Section

DASY5 Configuration:

- Probe: ES3DV3 - SN3149; ConvF(6.22, 6.22, 6.22); Calibrated: 25.09.09
- Electronics: DAE4 Sn771; Calibration: 19.11.09
- Phantom: 2mm Oval Phantom ELI4; Type: QDOVA001BB
- Measurement SW: DASY5, V5.0 Build 119.9; Postprocessing SW: SEMCAD, V13.2 Build 87

Pin=250mW; d=15mm/Zoom Scan (7x7x7)/Cube 0:

Measurement grid: dx=5mm, dy=5mm, dz=5mm

Reference Value = 54.0 V/m; Power Drift = -0.025 dB

Peak SAR (extrapolated) = 3.78 W/kg

SAR(1 g) = 2.41 mW/g; SAR(10 g) = 1.57 mW/g

Maximum value of SAR (measured) = 2.70 mW/g

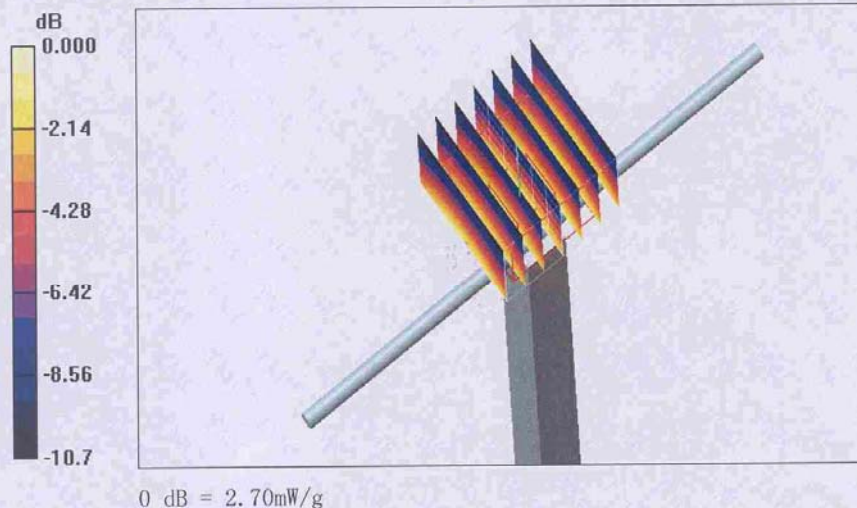

工业和信息化部通信计量中心
Telecommunication Metrology Center of MIIT



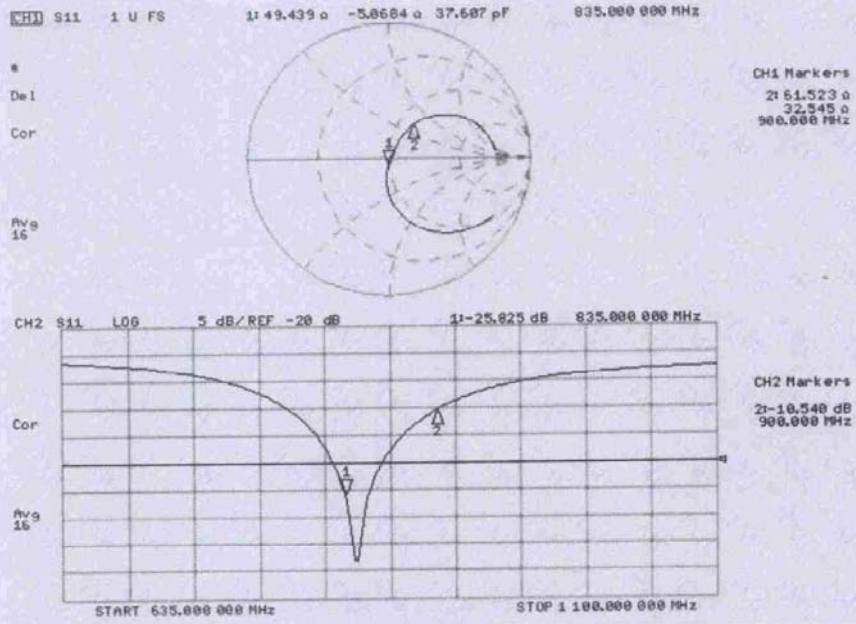

Impedance Measurement Plot for Body TSL



1900 MHz Dipole Calibration Certificate

工业和信息化部通信计量中心
Telecommunication Metrology Center of MIIT







校准
CNAS L0442

Client **TMC** Certificate No: **D1900V2-541_Feb10**

CALIBRATION CERTIFICATE

Object: D1900V2 - SN: 541

Calibration Procedure(s): TMC-XZ-01-027
Calibration procedure for dipole validation kits

Calibration date: February 26, 2010

Condition of the calibrated item: In Tolerance

This calibration Certificate documents the traceability to national standards, which realize the physical units of measurements(SI). The measurements and the uncertainties with confidence probability are given on the following pages and are part of the certificate.

All calibrations have been conducted in the closed laboratory facility: environment temperature(22±3)°C and humidity<70%.

Calibration Equipment used (M&TE critical for calibration)

Primary Standards	ID #	Cal Date(Calibrated by, Certificate No.)	Scheduled Calibration
Power Meter NRVD	101253	04-Sep-09 (TMC, No. JZ09-248)	Sep-10
Power sensor NRV-Z5	100333	04-Sep-09 (TMC, No. JZ09-248)	Sep-10
Reference Probe ES3DV3	SN 3149	25-Sep-09(SPEAG, No.ES3-3149_Sep09)	Sep-10
DAE4	SN 771	19-Nov-09(SPEAG, No.DAE4-771_Nov09)	Nov-10
RF generator E4438C	MY45092879	18-Jun-09(TMC, No.JZ09-302)	Jun-10
Network Analyzer 8753E	US38433212	29-Aug-09(TMC, No.JZ09-056)	Aug-10

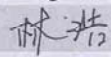
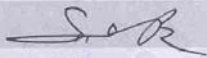
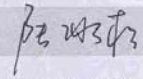
	Name	Function	Signature
Calibrated by:	Lin Hao	SAR Test Engineer	
Reviewed by:	Qi Dianyuan	SAR Project Leader	
Approved by:	Lu Bingsong	Deputy Director of the laboratory	

Issued: February 26, 2010

This calibration certificate shall not be reproduced except in full without written approval of the laboratoty.

Certificate No: D1900V2-541_Feb10

Page 1 of 9

工业和信息化部通信计量中心
Telecommunication Metrology Center of MIIT

**Glossary:**

TSL	tissue simulating liquid
ConvF	sensitivity in TSL / NORM _{x,y,z}
N/A	not applicable or not measured

Calibration is Performed According to the Following Standards:

- a) IEEE Std 1528-2003, "IEEE Recommended Practice for Determining the Peak Spatial-Averaged Specific Absorption Rate (SAR) in the Human Head from Wireless Communications Devices: Measurement Techniques", December 2003
- b) IEC 62209-1, "Procedure to measure the Specific Absorption Rate (SAR) For hand-held devices used in close proximity to the ear (frequency range of 300MHz to 3GHz)", February 2005
- c) Federal Communications Commission Office of Engineering & Technology (FCC OET), "Evaluating Compliance with FCC Guidelines for Human Exposure to Radiofrequency Electromagnetic Fields; Additional Information for Evaluating Compliance of Mobile and Portable Devices with FCC Limits for Human Exposure to Radiofrequency Emissions", Supplement C (Edition 01-01) to Bulletin 65

Additional Documentation:

- d) DASY System Handbook

Methods Applied and Interpretation of Parameters:

- Measurement Conditions: Further details are available from the Validation Report at the end of the certificate. All figures stated in the certificate are valid at the frequency indicated.
- Antenna Parameters with TSL: The dipole is mounted with the spacer to position its feed point exactly below the center marking of the flat phantom section, with the arms oriented parallel to the body axis.
- Feed Point Impedance and Return Loss: These parameters are measured with the dipole positioned under the liquid filled phantom. The impedance stated is transformed from the measurement at the SMA connector to the feed point. The Return Loss ensures low reflected power. No uncertainty required.
- Electrical Delay: One-way delay between the SMA connector and the antenna feed point. No uncertainty required.
- SAR measured: SAR measured at the stated antenna input power.
- SAR normalized: SAR as measured, normalized to an input power of 1 W at the antenna connector.
- SAR for nominal TSL parameters: The measured TSL parameters are used to calculate the nominal SAR result.

Measurement Conditions

DASY system configuration, as far as not given on page 1.

DASY Version	DASY5	V5.0
Extrapolation	Advanced Extrapolation	
Phantom	2mm Oval Phantom EL14	
Distance Dipole Center - TSL	10 mm	with Spacer
Zoom Scan Resolution	dx, dy, dz = 5 mm	
Frequency	1900 MHz \pm 1 MHz	

Head TSL parameters

The following parameters and calculations were applied.

	Temperature	Permittivity	Conductivity
Nominal Head TSL parameters	22.0 °C	40.0	1.40 mho/m
Measured Head TSL parameters	(22.0 \pm 0.2) °C	39.6 \pm 6 %	1.40mho/m \pm 6 %
Head TSL temperature during test	(21.9 \pm 0.2) °C	----	----

SAR result with Head TSL

SAR averaged over 1 cm^3 (1 g) of Head TSL	Condition	
SAR measured	250 mW input power	9.91 mW / g
SAR normalized	normalized to 1W	39.6 mW / g
SAR for nominal Head TSL parameters ¹	normalized to 1W	39.4 mW / g \pm 17.0 % (k=2)

SAR averaged over 10 cm^3 (10 g) of Head TSL	Condition	
SAR measured	250 mW input power	5.05 mW / g
SAR normalized	normalized to 1W	20.2 mW / g
SAR for nominal Head TSL parameters ¹	normalized to 1W	20.1 mW / g \pm 16.5 % (k=2)

¹ Correction to nominal TSL parameters according to d), chapter "SAR Sensitivities"

Body TSL parameters

The following parameters and calculations were applied.

	Temperature	Permittivity	Conductivity
Nominal Body TSL parameters	22.0 °C	53.3	1.52 mho/m
Measured Body TSL parameters	(22.0 ± 0.2) °C	52.5 ± 6%	1.51 mho/m ± 6 %
Body TSL temperature during test	(21.8 ± 0.2) °C	----	----

SAR result with Body TSL

SAR averaged over 1 cm^3 (1 g) of Body TSL	Condition	
SAR measured	250 mW input power	10.4 mW / g
SAR normalized	normalized to 1W	41.6 mW / g
SAR for nominal Body TSL parameters ²	normalized to 1W	41.4 mW / g ± 17.0 % (k=2)

SAR averaged over 10 cm^3 (10 g) of Body TSL	Condition	
SAR measured	250 mW input power	5.24 mW / g
SAR normalized	normalized to 1W	21.0 mW / g
SAR for nominal Body TSL parameters ²	normalized to 1W	20.9 mW / g ± 16.5 % (k=2)

² Correction to nominal TSL parameters according to d), chapter "SAR Sensitivities"

Appendix

Antenna Parameters with Head TSL

Impedance, transformed to feed point	$54.8\Omega + 4.0 j\Omega$
Return Loss	- 23.7dB

Antenna Parameters with Body TSL

Impedance, transformed to feed point	$47.9\Omega + 7.1 j\Omega$
Return Loss	- 22.6dB

General Antenna Parameters and Design

Electrical Delay (one direction)	1.201 ns
----------------------------------	----------

After long term use with 100W radiated power, only a slight warming of the dipole near the feedpoint can be measured.

The dipole is made of standard semirigid coaxial cable. The center conductor of the feeding line is directly connected to the second arm of the dipole. The antenna is therefore short-circuited for DC-signals.
No excessive force must be applied to the dipole arms, because they might bend or the soldered connections near the feedpoint may be damaged.

Additional EUT Data

Manufactured by	SPEAG
Manufactured on	October 4, 2001

工业和信息化部通信计量中心
Telecommunication Metrology Center of MIIT



DASY5 Validation Report for Head TSL

Date/Time: 2010-2-26 15:20:47

Test Laboratory: TMC, Beijing, China

DUT: Dipole 1900 MHz; Type: D1900V2; Serial: SN: 541

Communication System: CW Frequency: 1900 MHz Duty Cycle: 1:1

Medium: Head 1900MHz

Medium parameters used: $f = 1900$ MHz; $\sigma = 1.40$ mho/m; $\epsilon_r = 39.6$; $\rho = 1000$ kg/m³

Phantom section: Flat Section

DASY5 Configuration:

- Probe: ES3DV3 - SN3149; ConvF(5.03, 5.03, 5.03); Calibrated: 25.09.09
- Electronics: DAE4 Sn771; Calibration: 19.11.09
- Phantom: 2mm Oval Phantom ELI4; Type: QDOVA001BB
- Measurement SW: DASY5, V5.0 Build 119.9; Postprocessing SW: SEMCAD, V13.2 Build 87

Pin=250mW; d=10mm/Zoom Scan (7x7x7)/Cube 0:

Measurement grid: dx=5mm, dy=5mm, dz=5mm

Reference Value = 85.1 V/m; Power Drift = -0.057 dB

Peak SAR (extrapolated) = 18.8 W/kg

SAR(1 g) = 9.91 mW/g; SAR(10 g) = 5.05 mW/g

Maximum value of SAR (measured) = 11.5 mW/g



0 dB = 11.5mW/g

工业和信息化部通信计量中心
Telecommunication Metrology Center of MIIT



Impedance Measurement Plot for Head TSL

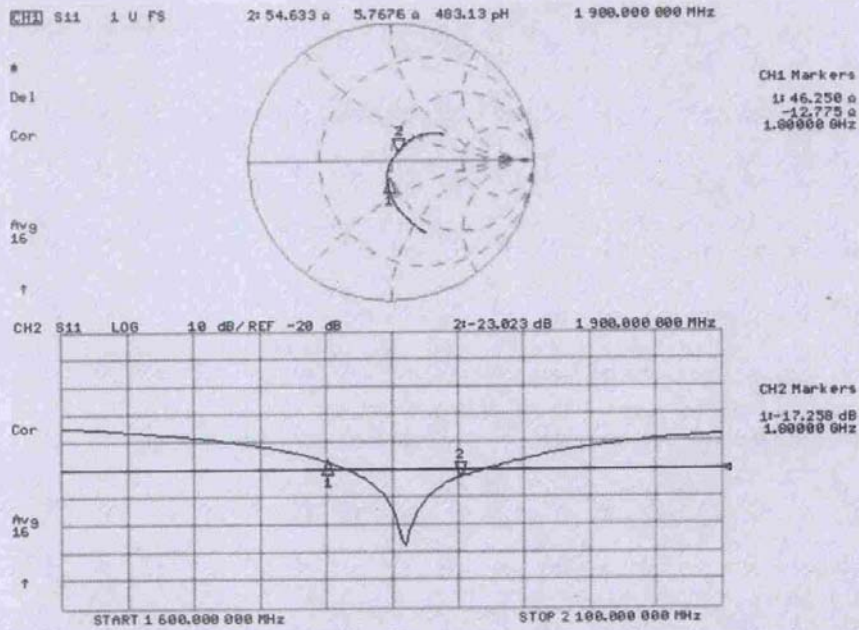

工业和信息化部通信计量中心
Telecommunication Metrology Center of MIIT



DASY5 Validation Report for Body TSL

Date/Time: 2010-2-26 10:41:08

Test Laboratory: TMC, Beijing, China

DUT: Dipole 1900 MHz; Type: D1900V2; Serial: SN: 541

Communication System: CW Frequency: 1900 MHz Duty Cycle: 1:1

Medium: Body 1900MHz

Medium parameters used: $f = 1900$ MHz; $\sigma = 1.51$ mho/m; $\epsilon_r = 52.5$; $\rho = 1000$ kg/m³

Phantom section: Flat Section

DASY5 Configuration:

- Probe: ES3DV3 - SN3149; ConvF(4.68, 4.68, 4.68); Calibrated: 25.09.09
- Electronics: DAE4 Sn771; Calibration: 19.11.09
- Phantom: 2mm Oval Phantom ELI4; Type: QDOVA001BB
- Measurement SW: DASY5, V5.0 Build 119.9; Postprocessing SW: SEMCAD, V13.2 Build 87

Pin=250mW; d=10mm/Zoom Scan (7x7x7)/Cube 0:

Measurement grid: dx=5mm, dy=5mm, dz=5mm

Reference Value = 80.2 V/m; Power Drift = -0.009 dB

Peak SAR (extrapolated) = 19.1 W/kg

SAR(1 g) = 10.4 mW/g; SAR(10 g) = 5.24 mW/g

Maximum value of SAR (measured) = 12.0 mW/g

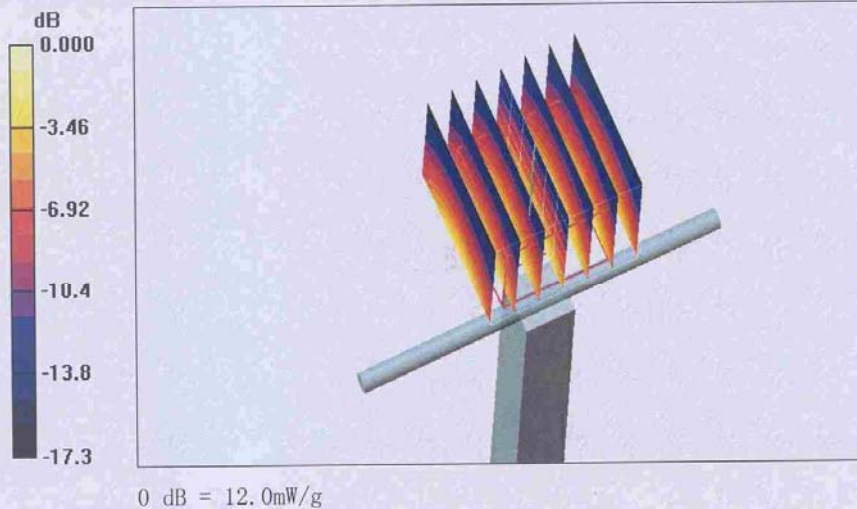

工业和信息化部通信计量中心
Telecommunication Metrology Center of MIIT



Impedance Measurement Plot for Body TSL

CH1 S11 1 U FS 2: 47.564 Ω 7.0098 μ 587.18 μ H 1.900.000.000 MHz

De1
Cor
Avg
16

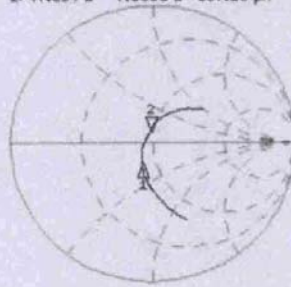

CH1 Markers
1: 47.211 Ω
-13.992 μ
1.60000 GHz

CH2 S11 LOG 4 dB/REF -20 dB 2: -22.401 dB 1.900.000.000 MHz

Cor
Avg
16

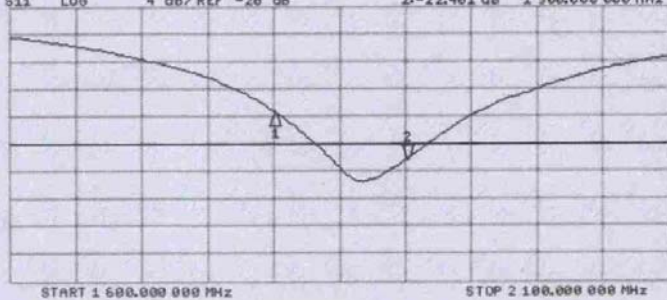

CH2 Markers
1: -15.338 dB
1.60000 GHz

START 1.600.000.000 MHz

STOP 2.100.000.000 MHz

2450 MHz Dipole Calibration Certificate

Calibration Laboratory of
Schmid & Partner
Engineering AG
Zeughausstrasse 43, 8004 Zurich, Switzerland



S Schweizerischer Kalibrierdienst
C Service suisse d'étalonnage
S Servizio svizzero di taratura
S Swiss Calibration Service

Accredited by the Swiss Accreditation Service (SAS)
The Swiss Accreditation Service is one of the signatories to the EA
Multilateral Agreement for the recognition of calibration certificates

Accreditation No.: SCS 108

Client **TMC (Auden)**

Certificate No. **D2450V2-853_Sep10**

CALIBRATION CERTIFICATE

Object: **D2450V2 - SN: 853**

Calibration procedure(s): **QA CAL-05 v7
Calibration procedure for dipole validation kits**

Calibration date: **September 27, 2010**

This calibration certificate documents the traceability to national standards, which realize the physical units of measurements (SI).
The measurements and the uncertainties with confidence probability are given on the following pages and are part of the certificate.

All calibrations have been conducted in the closed laboratory facility; environment temperature (22 ± 3)°C and humidity < 70%.

Calibration Equipment used (M&TE critical for calibration)

Primary Standards	ID #	Cal Date (Certificate No.)	Scheduled Calibration
Power meter EPM-442A	GB37480704	06-Oct-09 (No. 217-01086)	Oct-10
Power sensor HP 8481A	US37292783	06-Oct-09 (No. 217-01086)	Oct-10
Reference 20 dB Attenuator	SN: 5088 (20g)	30-Mar-10 (No. 217-01150)	Mar-11
Type-N mismatch combination	SN: 5047.2 / 06327	30-Mar-10 (No. 217-01162)	Mar-11
Reference Probe ES3DV3	SN: 3205	30-Apr-10 (No. ES3-3205_Apr10)	Apr-11
DAE4	SN: 801	10-Jun-10 (No. DAE4-601_Jun10)	Jun-11
Secondary Standards	ID #	Check Date (in house)	Scheduled Check
Power sensor HP 8481A	MY41092317	18-Oct-02 (in house check Oct-09)	In house check: Oct-11
RF generator R&S SMT-06	100005	4-Aug-99 (in house check Oct-09)	In house check: Oct-11
Network Analyzer HP 8753E	US37390585 94200	18-Oct-01 (in house check Oct-09)	In house check: Oct-10

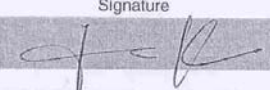
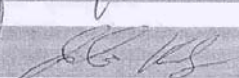
	Name	Function	Signature
Calibrated by:	Jeton Kastrati	Laboratory Technician	
Approved by:	Katja Pokovic	Technical Manager	

Issued: September 29, 2010

This calibration certificate shall not be reproduced except in full without written approval of the laboratory.

Calibration Laboratory of
Schmid & Partner
Engineering AG
Zeughausstrasse 43, 8004 Zurich, Switzerland



S Schweizerischer Kalibrierdienst
C Service suisse d'étalonnage
S Servizio svizzero di taratura
S Swiss Calibration Service

Accredited by the Swiss Accreditation Service (SAS)
The Swiss Accreditation Service is one of the signatories to the EA
Multilateral Agreement for the recognition of calibration certificates

Accreditation No.: SCS 108

Glossary:

TSL	tissue simulating liquid
ConvF	sensitivity in TSL / NORM x,y,z
N/A	not applicable or not measured

Calibration is Performed According to the Following Standards:

- a) IEEE Std 1528-2003, "IEEE Recommended Practice for Determining the Peak Spatial-Averaged Specific Absorption Rate (SAR) in the Human Head from Wireless Communications Devices: Measurement Techniques", December 2003
- b) IEC 62209-1, "Procedure to measure the Specific Absorption Rate (SAR) for hand-held devices used in close proximity to the ear (frequency range of 300 MHz to 3 GHz)", February 2005
- c) Federal Communications Commission Office of Engineering & Technology (FCC OET), "Evaluating Compliance with FCC Guidelines for Human Exposure to Radiofrequency Electromagnetic Fields; Additional Information for Evaluating Compliance of Mobile and Portable Devices with FCC Limits for Human Exposure to Radiofrequency Emissions", Supplement C (Edition 01-01) to Bulletin 65

Additional Documentation:

- d) DASY4/5 System Handbook

Methods Applied and Interpretation of Parameters:

- *Measurement Conditions:* Further details are available from the Validation Report at the end of the certificate. All figures stated in the certificate are valid at the frequency indicated.
- *Antenna Parameters with TSL:* The dipole is mounted with the spacer to position its feed point exactly below the center marking of the flat phantom section, with the arms oriented parallel to the body axis.
- *Feed Point Impedance and Return Loss:* These parameters are measured with the dipole positioned under the liquid filled phantom. The impedance stated is transformed from the measurement at the SMA connector to the feed point. The Return Loss ensures low reflected power. No uncertainty required.
- *Electrical Delay:* One-way delay between the SMA connector and the antenna feed point. No uncertainty required.
- *SAR measured:* SAR measured at the stated antenna input power.
- *SAR normalized:* SAR as measured, normalized to an input power of 1 W at the antenna connector.
- *SAR for nominal TSL parameters:* The measured TSL parameters are used to calculate the nominal SAR result.

Measurement Conditions

DASY system configuration, as far as not given on page 1.

DASY Version	DASY5	V52.2
Extrapolation	Advanced Extrapolation	
Phantom	Modular Flat Phantom V5.0	
Distance Dipole Center - TSL	10 mm	with Spacer
Zoom Scan Resolution	dx, dy, dz = 5 mm	
Frequency	2450 MHz ± 1 MHz	

Head TSL parameters

The following parameters and calculations were applied.

	Temperature	Permittivity	Conductivity
Nominal Head TSL parameters	22.0 °C	39.2	1.80 mho/m
Measured Head TSL parameters	(22.0 ± 0.2) °C	39.0 ± 6 %	1.74 mho/m ± 6 %
Head TSL temperature during test	(21.5 ± 0.2) °C	---	---

SAR result with Head TSL

SAR averaged over 1 cm ³ (1 g) of Head TSL	Condition	
SAR measured	250 mW input power	13.1 mW / g
SAR normalized	normalized to 1W	52.4 mW / g
SAR for nominal Head TSL parameters	normalized to 1W	53.2 mW / g ± 17.0 % (k=2)

SAR averaged over 10 cm ³ (10 g) of Head TSL	condition	
SAR measured	250 mW input power	6.16 mW / g
SAR normalized	normalized to 1W	24.6 mW / g
SAR for nominal Head TSL parameters	normalized to 1W	24.8 mW / g ± 16.5 % (k=2)

Body TSL parameters

The following parameters and calculations were applied.

	Temperature	Permittivity	Conductivity
Nominal Body TSL parameters	22.0 °C	52.7	1.95 mho/m
Measured Body TSL parameters	(22.0 ± 0.2) °C	52.5 ± 6 %	1.95 mho/m ± 6 %
Body TSL temperature during test	(21.6 ± 0.2) °C	----	----

SAR result with Body TSL

SAR averaged over 1 cm ³ (1 g) of Body TSL	Condition	
SAR measured	250 mW input power	12.9 mW / g
SAR normalized	normalized to 1W	51.6 mW / g
SAR for nominal Body TSL parameters	normalized to 1W	51.5 mW / g ± 17.0 % (k=2)

SAR averaged over 10 cm ³ (10 g) of Body TSL	condition	
SAR measured	250 mW input power	5.98 mW / g
SAR normalized	normalized to 1W	23.9 mW / g
SAR for nominal Body TSL parameters	normalized to 1W	23.9 mW / g ± 16.5 % (k=2)

Appendix

Antenna Parameters with Head TSL

Impedance, transformed to feed point	54.6 Ω + 2.8 j Ω
Return Loss	- 25.8 dB

Antenna Parameters with Body TSL

Impedance, transformed to feed point	49.4 Ω + 4.4 j Ω
Return Loss	- 27.1 dB

General Antenna Parameters and Design

Electrical Delay (one direction)	1.164 ns
----------------------------------	----------

After long term use with 100W radiated power, only a slight warming of the dipole near the feedpoint can be measured.

The dipole is made of standard semirigid coaxial cable. The center conductor of the feeding line is directly connected to the second arm of the dipole. The antenna is therefore short-circuited for DC-signals.

No excessive force must be applied to the dipole arms, because they might bend or the soldered connections near the feedpoint may be damaged.

Additional EUT Data

Manufactured by	SPEAG
Manufactured on	November 10, 2009

DASY5 Validation Report for Head TSL

Date/Time: 24.09.2010 14:10:17

Test Laboratory: SPEAG, Zurich, Switzerland

DUT: Dipole 2450 MHz; Type: D2450V2; Serial: D2450V2 - SN:853

Communication System: CW; Frequency: 2450 MHz; Duty Cycle: 1:1

Medium: HSL U12 BB

Medium parameters used: $f = 2450$ MHz; $\sigma = 1.74$ mho/m; $\epsilon_r = 39$; $\rho = 1000$ kg/m³

Phantom section: Flat Section

Measurement Standard: DASY5 (IEEE/IEC/ANSI C63.19-2007)

DASY5 Configuration:

- Probe: E53DV3 - SN3205; ConvF(4.53, 4.53, 4.53); Calibrated: 30.04.2010
- Sensor-Surface: 3mm (Mechanical Surface Detection)
- Electronics: DAE4 Sn601; Calibrated: 10.06.2010
- Phantom: Flat Phantom 5.0 (front); Type: QD000P50AA; Serial: 1001
- Measurement SW: DASY52, V52.2 Build 0, Version 52.2.0 (163)
- Postprocessing SW: SEMCAD X, V14.2 Build 2, Version 14.2.2 (1685)

Pin=250 mW/d=10mm, dist=3.0mm (ES-Probe)/Zoom Scan (7x7x7)/Cube 0: Measurement
grid; dx=5mm, dy=5mm, dz=5mm

Reference Value = 101.7 V/m; Power Drift = 0.028 dB

Peak SAR (extrapolated) = 26.7 W/kg

SAR(1 g) = 13.1 mW/g; SAR(10 g) = 6.16 mW/g

Maximum value of SAR (measured) = 16.7 mW/g

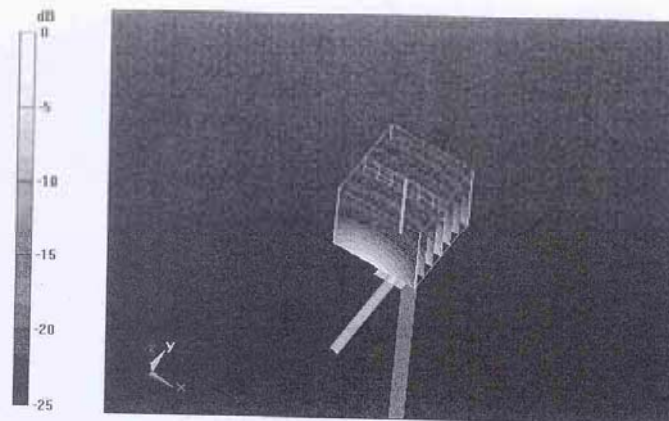

0 dB = 16.7mW/g

Impedance Measurement Plot for Head TSL

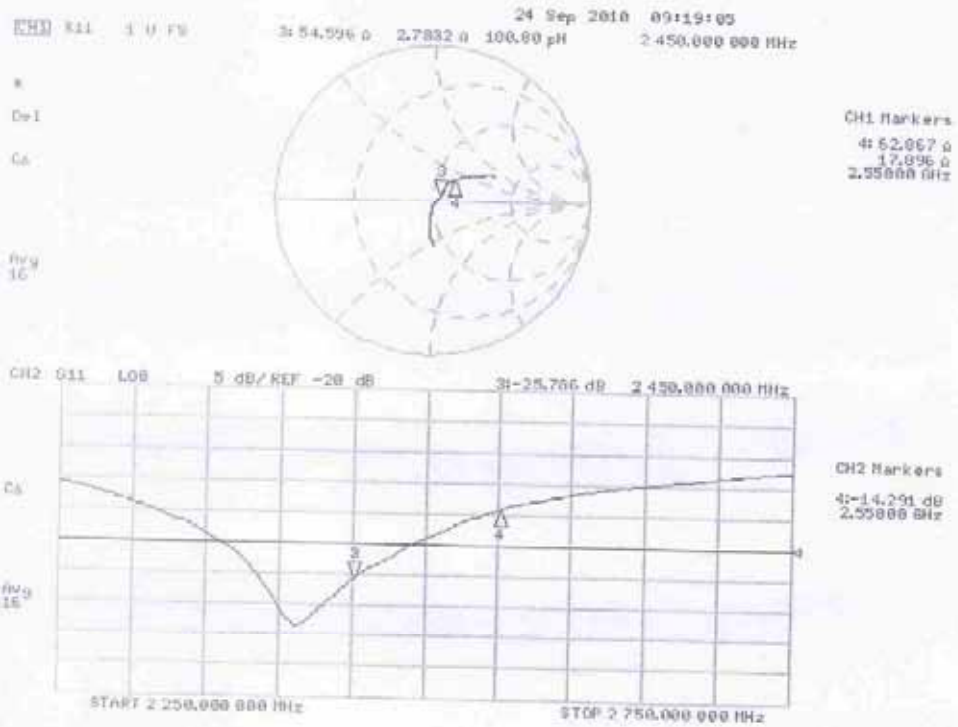

Validation Report for Body

Date/Time: 27.09.2010 13:39:49

Test Laboratory: SPEAG, Zurich, Switzerland

DUT: Dipole 2450 MHz; Type: D2450V2; Serial: D2450V2 - SN:853

Communication System: CW; Frequency: 2450 MHz; Duty Cycle: 1:1

Medium: MSL U12 BB

Medium parameters used: $f = 2450$ MHz; $\sigma = 1.95$ mho/m; $\epsilon_r = 52.6$; $\rho = 1000$ kg/m³

Phantom section: Flat Section

Measurement Standard: DASYS (IEEE/IEC/ANSI C63.19-2007)

DASY5 Configuration:

- Probe: ES3DV3 - SN3205; ConvF(4.31, 4.31, 4.31); Calibrated: 30.04.2010
- Sensor-Surface: 3mm (Mechanical Surface Detection)
- Electronics: DAE4 Sn601; Calibrated: 10.06.2010
- Phantom: Flat Phantom 5.0 (back); Type: QD000P50AA; Serial: 1002
- Measurement SW: DASYS2, V52.2 Build 0, Version 52.2.0 (163)
- Postprocessing SW: SEMCAD X, V14.2 Build 2, Version 14.2.2 (1685)

Pin=250 mW /d=10mm, dist=3.0mm (ES-Probe)/Zoom Scan (7x7x7)/Cube 0; Measurement

grid: dx=5mm, dy=5mm, dz=5mm

Reference Value = 95.7 V/m; Power Drift = 0.045 dB

Peak SAR (extrapolated) = 27 W/kg

SAR(1 g) = 12.9 mW/g; SAR(10 g) = 5.98 mW/g

Maximum value of SAR (measured) = 16.9 mW/g

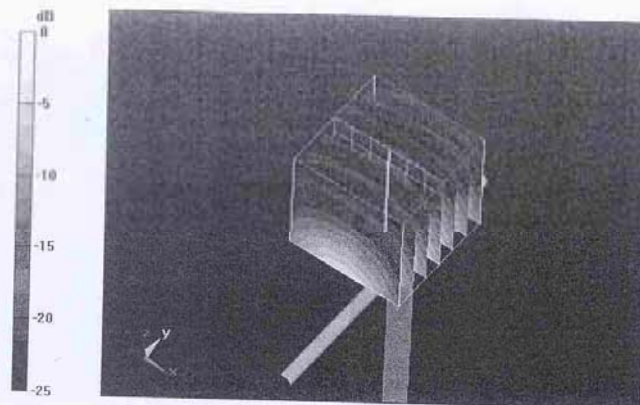

0 dB = 16.9mW/g

Impedance Measurement Plot for Body TSL

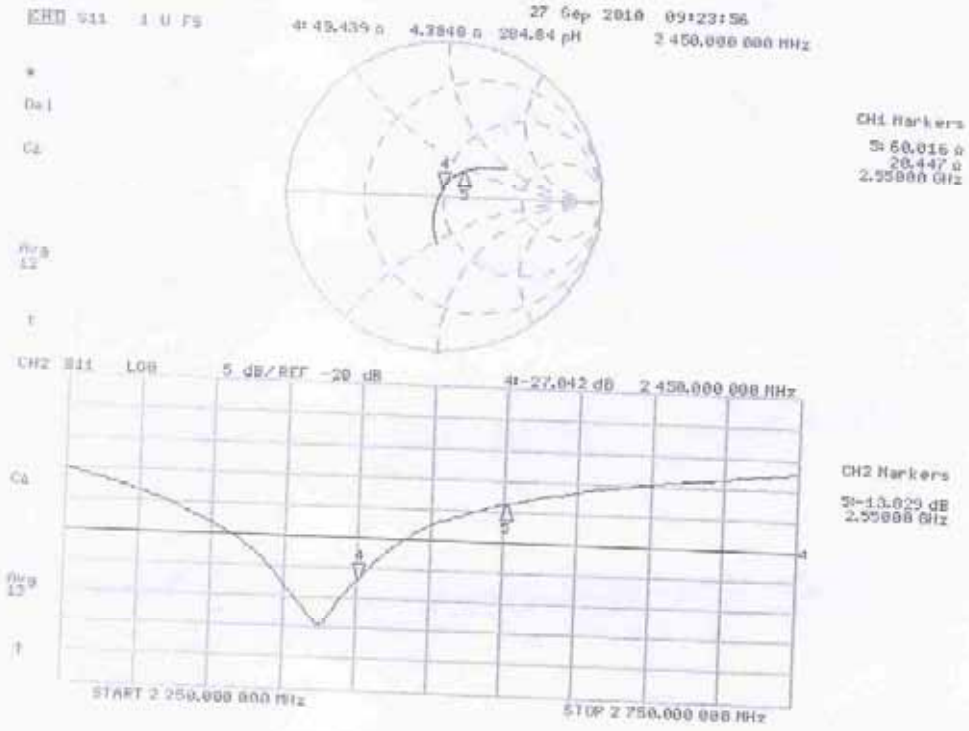

ANNEX E SPOT CHECK TEST

As the test lab for one touch 720D from TCT Mobile Limited, we, TMC Beijing, declare on our sole responsibility that, according to “Declaration of changes” provided by applicant, only the Spot check test should be performed. The test results are as below.

SAR Values (GSM 850 MHz Band - Head)

Frequency		Side	Test Position	Battery Type	SAR(1g) (W/kg)	
MHz	Ch.				Original data	Spot check data
848.8	251	Left	Touch	CAB31L0000C1	0.826	0.794

SAR Values (PCS 1900 MHz Band - Head)

Frequency		Side	Test Position	Battery Type	SAR(1g) (W/kg)	
MHz	Ch.				Original data	Spot check data
1880	661	Right	Touch	CAB31L0000C1	0.771	0.768

SAR Values (GSM 850 MHz Band - Body)

Frequency		Mode/Band	Test Position	Spacing (mm)	Battery Type	SAR(1g) (W/kg)	
MHz	Ch.					Original data	Spot check data
848.8	251	GPRS	Ground	15	CAB31L0000C1	1.05	1.04

SAR Values (PCS 1900 MHz Band - Body)

Frequency		Mode/Band	Test Position	Spacing (mm)	Battery Type	SAR(1g) (W/kg)	
MHz	Ch.					Original data	Spot check data
1880	661	GPRS	Ground	15	CAB31L0000C1	0.544	0.515

850 Left Cheek High

Date: 2012-2-29

Electronics: DAE4 Sn771

Medium: Head 850 MHz

Medium parameters used (interpolated): $f = 848.8$ MHz; $\sigma = 0.93$ mho/m; $\epsilon_r = 42.1$;
 $\rho = 1000$ kg/m³

Ambient Temperature: 23.0°C Liquid Temperature: 22.5°C

Communication System: GSM 850 Frequency: 848.8 MHz Duty Cycle: 1:8.3

Probe: ES3DV3 - SN3149 ConvF(6.56, 6.56, 6.56)

Cheek High/Area Scan (61x91x1): Measurement grid: dx=10mm, dy=10mm

Maximum value of SAR (interpolated) = 0.851 mW/g

Cheek High/Zoom Scan (7x7x7)/Cube 0: Measurement grid: dx=5mm, dy=5mm, dz=5mm

Reference Value = 12.399 V/m; Power Drift = -0.01 dB

Peak SAR (extrapolated) = 0.9740

SAR(1 g) = 0.794 mW/g; SAR(10 g) = 0.596 mW/g

Maximum value of SAR (measured) = 0.837 mW/g

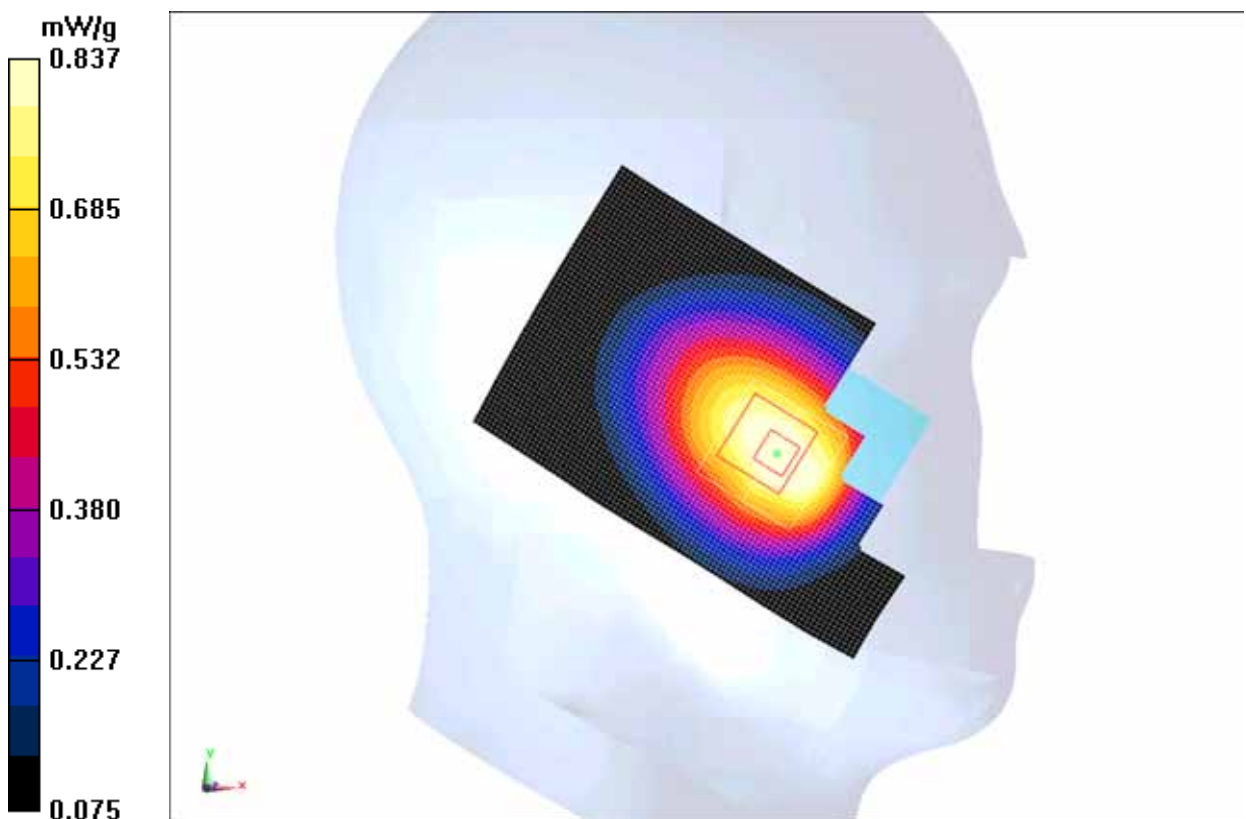

850MHz CH251

1900 Right Cheek Middle

Date: 2012-3-1

Electronics: DAE4 Sn771

Medium: Head 1900 MHz

Medium parameters used: $f = 1880$ MHz; $\sigma = 1.38$ mho/m; $\epsilon_r = 40.6$; $\rho = 1000$ kg/m³

Ambient Temperature: 23.0°C Liquid Temperature: 22.5°C

Communication System: GSM 1900MHz Frequency: 1880 MHz Duty Cycle: 1:8.3

Probe: ES3DV3 - SN3149 ConvF(5.03, 5.03, 5.03)

Cheek Middle/Area Scan (61x91x1): Measurement grid: dx=10mm, dy=10mm

Maximum value of SAR (interpolated) = 0.892 mW/g

Cheek Middle/Zoom Scan (7x7x7)/Cube 0: Measurement grid: dx=5mm, dy=5mm, dz=5mm

Reference Value = 10.753 V/m; Power Drift = 0.0079 dB

Peak SAR (extrapolated) = 1.3020

SAR(1 g) = 0.768 mW/g; SAR(10 g) = 0.412 mW/g

Maximum value of SAR (measured) = 0.861 mW/g

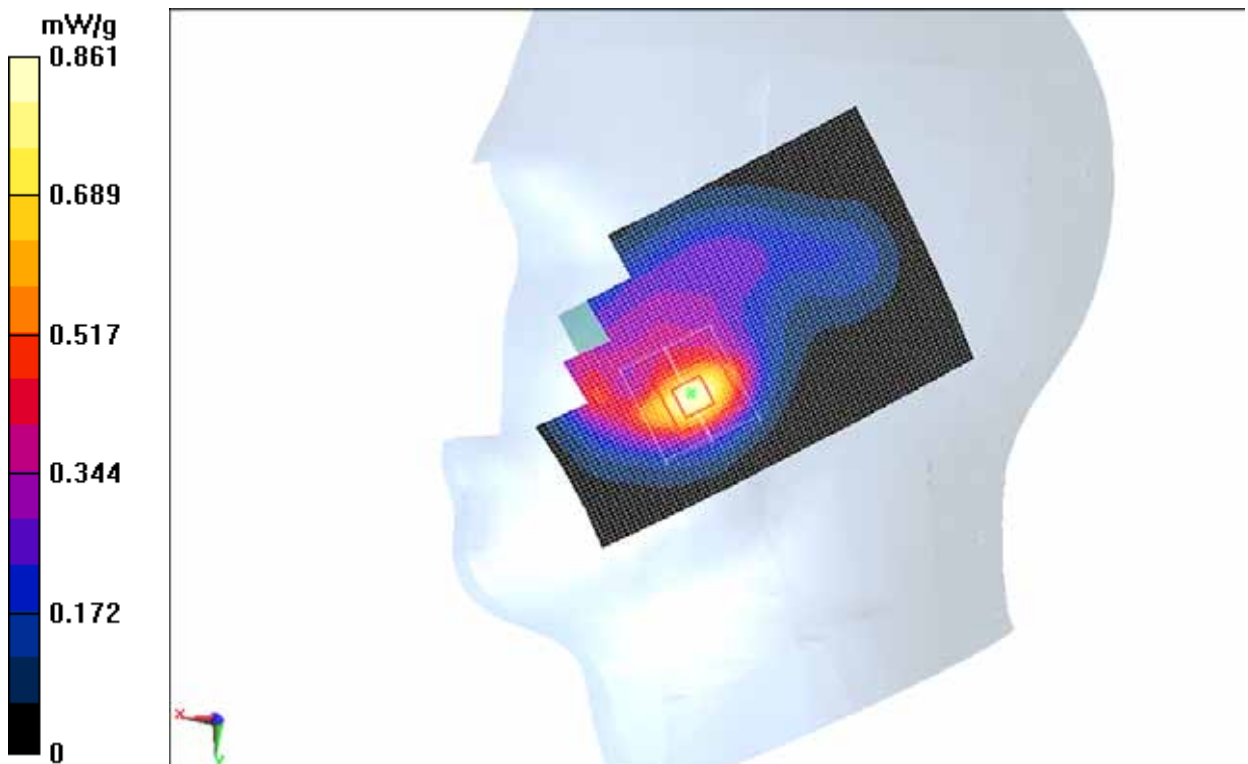

1900 MHz CH661

850 Body Towards Ground High

Date: 2012-2-29

Electronics: DAE4 Sn771

Medium: 900 Body

Medium parameters used (interpolated): $f = 848.8$ MHz; $\sigma = 0.99$ mho/m; $\epsilon_r = 53.1$;
 $\rho = 1000$ kg/m³

Ambient Temperature: 23.3°C Liquid Temperature: 22.5°C

Communication System: GSM 850 GPRS Frequency: 848.8 MHz Duty Cycle: 1:2

Probe: ES3DV3 - SN3149 ConvF(6.22, 6.22, 6.22)

Toward Ground High/Area Scan (61x101x1): Measurement grid: dx=10mm, dy=10mm

Maximum value of SAR (interpolated) = 1.126 mW/g

Toward Ground High/Zoom Scan (7x7x7)/Cube 0: Measurement grid: dx=5mm, dy=5mm, dz=5mm

Reference Value = 31.486 V/m; Power Drift = 0.03 dB

Peak SAR (extrapolated) = 1.3910

SAR(1 g) = 1.04 mW/g; SAR(10 g) = 0.752 mW/g

Maximum value of SAR (measured) = 1.110 mW/g

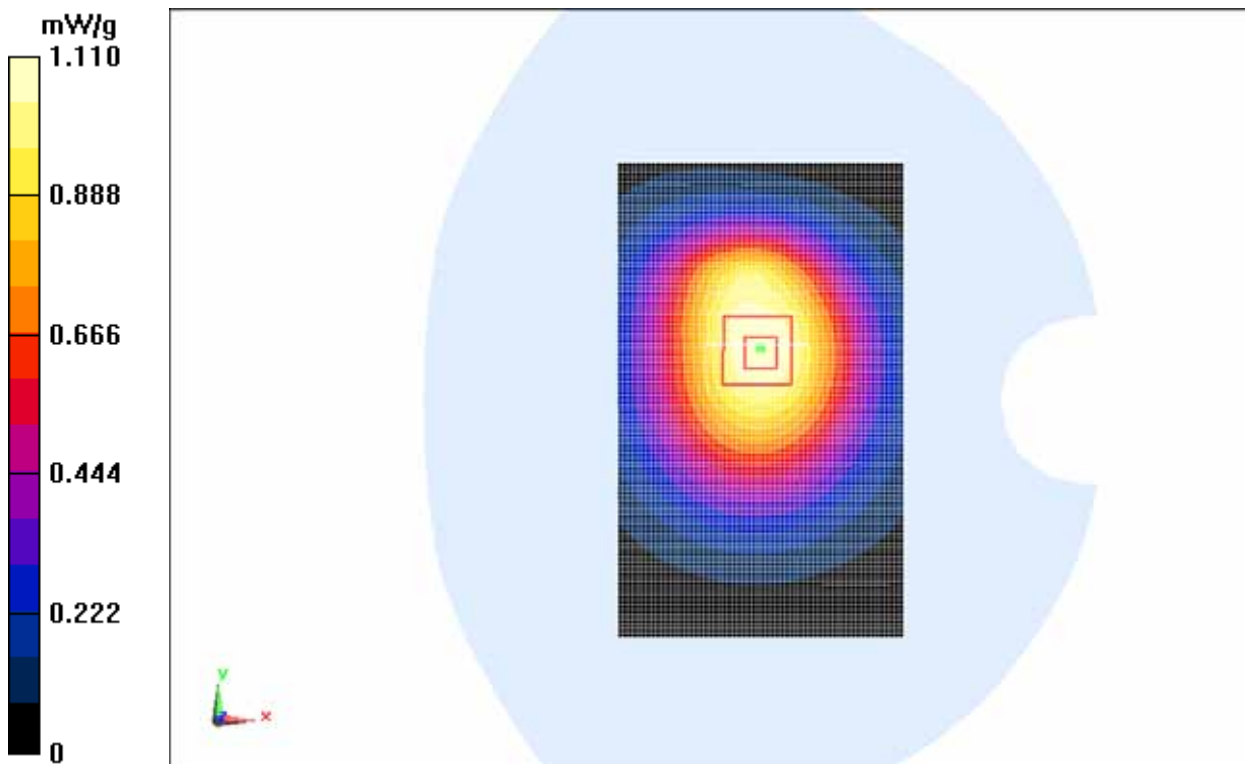

850 MHz CH251

1900 Body Towards Ground Middle

Date: 2012-3-1

Electronics: DAE4 Sn771

Medium: Body 1900 MHz

Medium parameters used: $f = 1880$ MHz; $\sigma = 1.499$ mho/m; $\epsilon_r = 53.287$; $\rho = 1000$ kg/m³

Ambient Temperature: 23.3°C Liquid Temperature: 22.5°C

Communication System: GSM 1900MHz GPRS Frequency: 1880 MHz Duty Cycle: 1:2

Probe: ES3DV3 - SN3149 ConvF(4.68, 4.68, 4.68)

Toward Ground Middle/Area Scan (61x101x1): Measurement grid: dx=10mm, dy=10mm

Maximum value of SAR (interpolated) = 0.564 mW/g

Toward Ground Middle/Zoom Scan (7x7x7)/Cube 0: Measurement grid: dx=5mm, dy=5mm, dz=5mm

Reference Value = 8.852 V/m; Power Drift = -0.14 dB

Peak SAR (extrapolated) = 0.8390

SAR(1 g) = 0.515 mW/g; SAR(10 g) = 0.305 mW/g

Maximum value of SAR (measured) = 0.557 mW/g

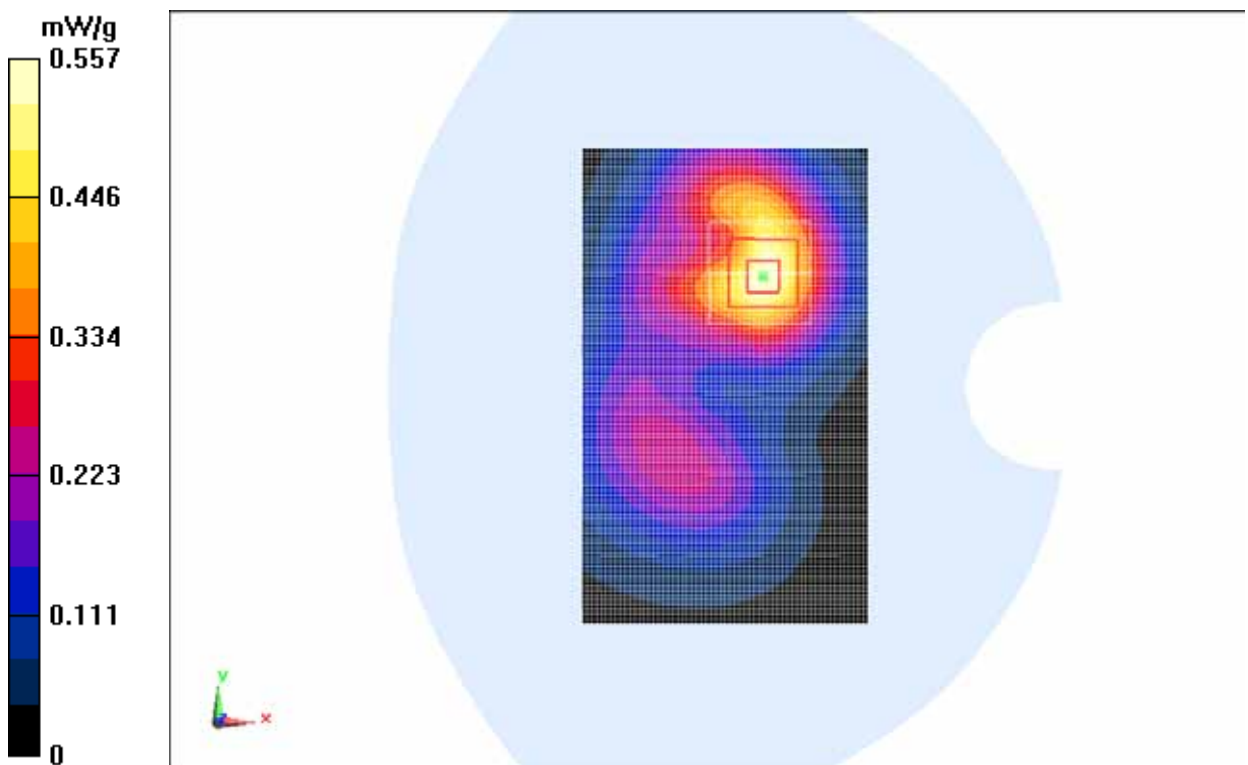

1900 MHz CH661