



CONFORMANCE TEST REPORT FOR HUMAN EXPOSURE TO ELECTROMAGNETIC FIELDS

Report No.: SRTC2011-H024-E0014

Product Name: GSM/GPRS/EDGE/WCDMA

Digital Mobile Phone with Bluetooth

Marketing Name: one touch 905A

Product Model: MINI3G A

Applicant: TCT Mobile Limited

Manufacture: TCT Mobile Limited

Specification: FCC OET Bulletin 65 (Edition 97-01)

Supplement C (Edition 01-01)

47CFR 2.1093

FCC ID: RAD153

The State Radio_monitoring_center Testing Center (SRTC)

No.80 Beilishi Road Xicheng District Beijing, China

Tel: 86-10-68009202 Fax: 86-10-68009205

Executive summary

Test report no.:	SRTC2011-H024-E0014
Product Model:	MINI3G A
Date of test:	2011.03.22
Date of report:	2011.03.28
Laboratory:	The State Radio_monitoring_center Testing Center (SRTC)
Test has been Carried out in accordance with:	<p>47CFR §2.1093</p> <p>Radiofrequency Radiation Exposure Evaluation: Portable Devices</p> <p>FCC OET Bulletin 65 (Edition 97-01), Supplement C (Edition 01-01)</p> <p>Evaluating Compliance with FCC Guidelines for Human Exposure to Radiofrequency Electromagnetic Fields</p> <p>RSS-102</p> <p>Evaluation Procedure for Mobile and Portable Radio Transmitters with Respect to Health Canada's Safety Code 6 for Exposure of Humans to Radio Frequency Fields</p> <p>IEEE 1528 - 2003</p> <p>IEEE Recommended Practice for Determining the Peak Spatial-Average Specific Absorption Rate (SAR) in the Human Head from Wireless Communications Devices: Measurement Technique</p>
Documentation:	The documentation of the testing performed on the tested devices is archived for 5 years at SRTC

Result summary:

Mode	CH/f(MHz)	Power (dBm)	Position	Sar Limit (1g avg) (mW/g)	Measured value (1g avg)(mW/g)	Result
Wcdma B2	9262/1852.4	22.4	Right cheek	1.6	1.23	PASS

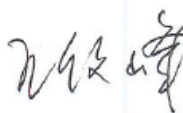
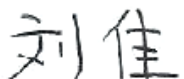
<p>This Test Report Is Issued by: Mr. Song Qizhu Director of the test lab</p> 	<p>Checked by: Mr. Wang Junfeng Deputy director of the test lab</p> 
<p>Tested by: Ms. Liu Jia Test engineer</p> 	<p>Issued date: 2011.04.26</p>

Tables of contents

1. GENERAL INFORMATION 3

 1.1 Notes of the test report 3

 1.2 Information about the testing laboratory 3

 1.3 Applicant’s details 3

 1.4 Manufacturer’s details 3

 1.5 Test Details 4

 1.6 Maximum Results 4

 1.6.1 GSM 4

 1.6.2 WCDMA 5

2. DESCRIPTION OF THE DEVICE UNDER TEST 6

 2.1 Description of the Antenna 6

 2.2 Picture of the EUT 7

 2.3 Test Positions for the Device under test 7

 2.4 Picture to demonstrate the required liquid depth 8

3. TEST CONDITIONS 9

 3.1 Temperature and Humidity 9

 3.2 Test Signal, Frequencies and Output Power 9

 3.3 SAR Measurement Set-up 9

4. DESCRIPTION OF THE TEST EQUIPMENT 10

 4.1 Measurement System and Components 10

 4.2 Phantoms 11

 4.3 Tissue Simulants 11

 4.3.1 Tissue Simulant Recipes 11

 4.3.2 System Checking 12

 4.3.3 Tissue Simulants used in the Measurements 13

5. DESCRIPTION OF THE TEST PROCEDURE 14

 5.1 Device Holder 14

 5.2 Test positions 14

 5.2.1 Against Phantom Head 14

 5.2.2 Body Worn Configuration 14

 5.3 Scan Procedure 15

 5.4 SAR Averaging Methods 15

6. MEASUREMENT UNCERTAINTY 16

7. RESULTS 17

 7.1 Test result 17

 7.2 Conducted power 24

 7.3 Summary of Measurement Results (Bluetooth) 26

APPENDIX A: SYSTEM CHECKING SCANS 27

APPENDIX B: MEASUREMENT SCANS 29

APPENDIX C: RELEVANT PAGES FROM PROBE CALIBRATION REPORT(S) 113

APPENDIX D: RELEVANT PAGES FROM DIPOLE VALIDATION KIT REPORT(S) 119

1. GENERAL INFORMATION

1.1 Notes of the test report

The test report may only be reproduced or published in full. Reproduction or publication of extracts from the report requires the prior written permission of The State Radio_monitoring_center Testing Center (SRTC).

The test results relate only to individual items of the samples which have been tested.

1.2 Information about the testing laboratory

Company: The State Radio_monitoring_center Testing Center (SRTC)
Address: No.80 Beilishi Road, Xicheng District, Beijing China
City: Beijing
Country or Region: China
Contacted person: Wang Junfeng
Tel: +86 10 68009181 +86 10 68009202
Fax: +86 10 68009195 +86 10 68009205
Email: wangjf@srrc.org.cn / wangjunfeng@srtc.org.cn

1.3 Applicant's details

Company: TCT Mobile Limited
Address: 5F, E building, No. 232, Liang Jing Road ZhangJiang High-Tech Park, Pudong Area
City: Shanghai
Country or Region: P.R.China
Grantee Code: RAD
Contacted Person: Gong Zhizhou
Tel: +86-21-61460890
Fax: +86-21-61460602
Email: zhizhou.gong@jrdcom.com

1.4 Manufacturer's details

Company: TCT Mobile Limited
Address: 5F, E building, No. 232, Liang Jing Road ZhangJiang High-Tech Park, Pudong Area
City: Shanghai
Country or Region: P.R.China
Contacted person: Gong Zhizhou
Tel: +86-21-61460890
Fax: +86-21-61460602
Email: zhizhou.gong@jrdcom.com

1.5 Test Details

Period of test	2011.03.22
Batteries used in testing	Li-Lon/CAB3120000C1/BYD LITHIUM BATTERY CO., LTD
	Li-Lon/CAB3120000C2/TIANJIN LISHEN BATTERY JOINT-STOCK CO.,LTD
State of sample	production unit
Headsets used in testing	CCB3160A10C2/Lianyun Electronic Technology CO.,LTD.
	CCB3160A10C3/Jiangxi Lianchuang Hongsheng Electronic Co.,LTD
H/W Version	PIO
S/W Version	sw132
IMEI	012525000006744
Device class/ Multislot class	B/12
DTM	N/A
Notes	<p>As the information described above, there are two different models of battery manufactured by two different companies, and two different models of headset manufactured by two different companies.</p> <p>The relevant tests have been performed in order to verify in which combination case (EUT exercised by only one model of battery and one model of headset) the EUT would have the worst features. So all the tests shown in this test report are performed when the EUT exercised by the battery CAB3120000C2 and the headset CCB3160A10C2.</p>

1.6 Maximum Results

The maximum measured SAR values for Head configuration and Body Worn configuration are given in section 1.6.1 and 1.6.2 respectively. The device conforms to the requirements of the standard(s) when the maximum measured SAR value is less than or equal to the limit.

1.6.1 GSM

The multi-slot mode configuration level in GPRS and EDGE is the class 12. The configurations including four slot modes below:

- 4 downlink and 1 uplink
- 3 downlink and 2 uplink
- 2 downlink and 3 uplink
- 1 downlink and 1 uplink

The DUT's output power was test through the conducted spurious emissions with the four slot modes, the maximum power was under 4 downlink and 1 uplink mode.

Therefore, during GPRS and EDGE test will choice 4 downlink and 1 uplink mode as the basic test mode.

Head Configuration

Mode	CH/f(MHz)	Power (dBm)	Position	Sar Limit (1g avg) (mW/g)	Measured value (1g avg)(mW/g)	Result
GSM850	189/836.4	32.71	Right cheek	1.6	1.20	PASS
GSM1900	512/1850.2	29.56	Left cheek	1.6	1.03	PASS

Body Worn Configuration

Mode	CH/f(MHz)	Power (dBm)	Position	Sar Limit (1g avg) (mW/g)	Measured value (1g avg)(mW/g)	Result
GPRS850	251/848.8	32.64	Towards phantom	1.6	1.04	PASS
GPRS1900	810/1909.8	29.69	Towards ground	1.6	0.80	PASS

1.6.2 WCDMA

The default test configuration is to measure SAR with an established radio link between the DUT and a communication test set using a 12.2 kbps RMC (reference measurement channel) configured in Test Loop Mode 1. The dedicated channel will be set with RMC type, and the transmit power control in ALL UP BITS.

Head Configuration

Mode	CH/f(MHz)	Power (dBm)	Position	Sar Limit (1g avg) (mW/g)	Measured value (1g avg)(mW/g)	Result
WCDMA B2	9262/1852.4	23.44	Right cheek	1.6	1.23	PASS
WCDMA B5	4233/846.6	23.05	Right cheek	1.6	0.81	PASS

Body Worn Configuration

Mode	CH/f(MHz)	Power (dBm)	Position	Sar Limit (1g avg) (mW/g)	Measured value (1g avg)(mW/g)	Result
WCDMA B2	9262/1852.4	23.44	Towards ground	1.6	1.02	PASS
WCDMA B5	4183/836.5	23.45	Towards ground	1.6	0.847	PASS

2. DESCRIPTION OF THE DEVICE UNDER TEST

Device category	production unit
Exposure environment	General population/uncontrolled

Modes and Bands of operation	GSM 850	GSM 1900	GPRS	EGPRS	WCDMA B2	WCDMA B5
Modulation Mode	GMSK	GMSK	GMSK	8-PSK /GMSK	QPSK	QPSK
Duty Cycle	1/8	1/8	1/4	1/2	1/1	1/1
Transmitter Frequency Range(MHz)	824-849	1850-1910	824-849 1850-1910	824-849 1850-1910	1850-1910	824-849

2.1 Description of the Antenna



The device has an internal antenna.

2.2 Picture of the EUT

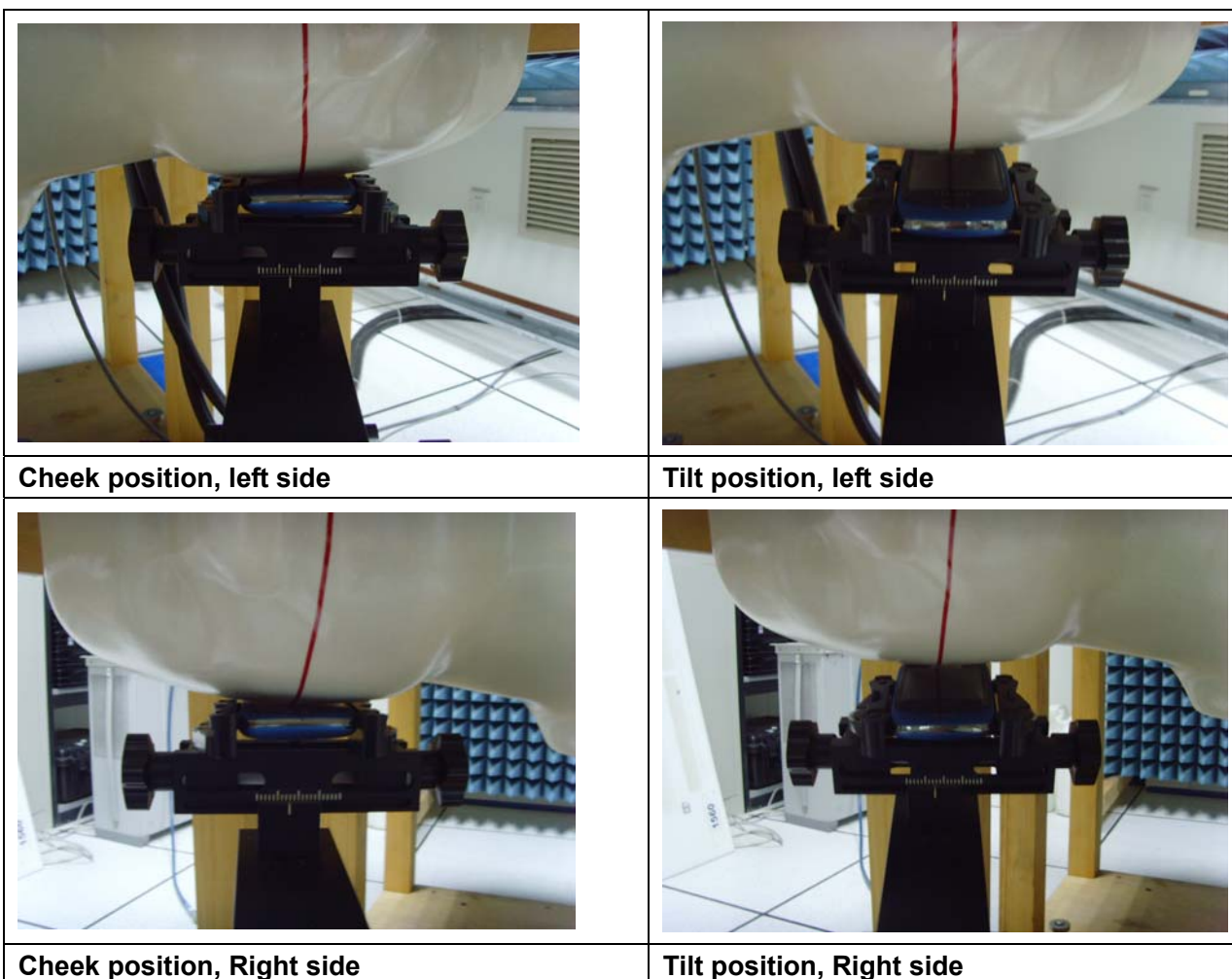

2.3 Test Positions for the Device under test



	
<p>FLAT position (towards ground)</p>	<p>15mm spacer</p>

2.4 Picture to demonstrate the required liquid depth

the liquid depth in the used SAM phantoms



Liquid depth for SAR Measurement

3. TEST CONDITIONS

3.1 Temperature and Humidity

Ambient temperature (° C)	21.0 to 23.0
Ambient humidity (RH %)	30 to 45

3.2 Test Signal, Frequencies and Output Power

The device was put into operation by using a call tester. Communication between the device and the call tester was established by air link.

The device output power was set to maximum power level for all tests; a fully charged battery was used for every test sequence.

In all operating bands the measurements were performed on lowest, middle and highest channels.

3.3 SAR Measurement Set-up

The system is based on a high precision robot (working range greater than 0.9m), which positions the probes with a positional repeatability of better than $\pm 0.02\text{mm}$. Special E- and H-field probes have been developed for measurements close to material discontinuity, the sensors of which are directly loaded with a Schottky diode and connected via highly resistive lines (length =300mm) to the data acquisition unit. A cell controller system contains the power supply, robot controller, teaches pendant (Joystick),and remote control, is used to drive the robot motors.

The PC consists of the Micron Pentium IV computer with Windows 2000 system and SAR Measurement Software DASY4 Professional, A/D interface card, monitor, mouse, and keyboard. The Stäubli Robot is connected to the cell controller to allow software manipulation of the robot.

A data acquisition electronic (DAE) circuit performs the signal amplification, signal multiplexing, AD-conversion, offset measurements, mechanical surface detection, collision detection, etc. is connected to the Electro-optical coupler (EOC). The EOC performs the conversion from the optical into digital electric signal of the DAE and transfers data to the PC plug-in card. The DAE consists of a highly sensitive electrometer-grade preamplifier with auto-zeroing, a channel and gain-switching multiplexer, a fast 16 bit AD-converter and a command decoder and control logic unit. Transmission to the PC-card is accomplished through an optical downlink for data and status information and an optical uplink for commands and clock lines.

The mechanical probe mounting device includes two different sensor systems for frontal and sidewise probe contacts. They are also used for mechanical surface detection and probe collision detection

The robot uses its own controller with a built in VME-bus computer.

4. DESCRIPTION OF THE TEST EQUIPMENT

4.1 Measurement System and Components

The measurements were performed using an automated near-field scanning system, DASY4, manufactured by Schmid & Partner Engineering AG (SPEAG) in Switzerland. The SAR extrapolation algorithm used in all measurements was the 'advanced extrapolation' algorithm.

The following table lists calibration dates of SPEAG components:

Test Equipment	Serial Number	Calibration interval	Calibration expiry
DAE4	720	1year	2012.01.19
Dosimetric E-field Probe ES3DV3	3128	1year	2011.06.22
Dipole Validation Kit, D900V2	171	2 years	2012.06.11
Dipole Validation Kit, D1800V2	2d084	2 years	2012.06.11
DASY4 software Version	4.7	N/A	N/A

Note: the Dipole Calibration interval is 24 months

Additional test equipment used in testing:

Test Equipment	Model	Serial Number	Calibration interval	Calibration expiry
Signal Generator	E4428C	MY45280865	1year	2011.08.20
Amplifier	5S1G4	0323472	N/A	N/A
Power meter	E4417A	MY45101182	1year	2011.08.20
Power Sensor	E4412A	MY41502214	1year	2011.08.20
Power Sensor	E4412A	MY41502130	1year	2011.08.20
Call Tester	8960	GB43194054	1year	2011.08.20
Network Analyzer	8714ET	US40372083	1year	2011.08.20
Dielectric Probe Kit	85070D	US33030365	N/A	N/A

Detailed information of Isotropic E-field Probe Type ES3DV3

Construction	Symmetrical design with triangular core Interleaved sensors Built-in shielding against static charges PEEK enclosure material (resistant to organic solvents, e.g., DGBE)
Calibration	Calibration certificate in Appendix C
Frequency	10 MHz to 4 GHz; Linearity: ± 0.2 dB (30 MHz to 4 GHz)
Optical Surface Detection	± 0.2 mm repeatability in air and clear liquids over diffuse reflecting surfaces
Dimensions	Overall length: 330 mm (Tip: 20 mm)

	Tip diameter: 3.9 mm (Body: 12 mm) Distance from probe tip to dipole centers: 2.0 mm
Dynamic Range	5 μ W/g to > 100 mW/g; Linearity: \pm 0.2 dB
Application	General dosimetry up to 4 GHz Dosimetry in strong gradient fields Compliance tests of mobile phones

4.2 Phantoms

The phantom used for all tests i.e. for both system checks and device testing, was the twinheaded "SAM Phantom", manufactured by SPEAG. The phantom conforms to the requirements of IEEE 1528 - 2003.

System checking was performed using the flat section, whilst Head SAR tests used the left and right head profile sections. Body SAR testing also used the flat section between the head profiles.

The SPEAG device holder (see Section 5.1) was used to position the device in all tests whilst a tripod was used to position the validation dipoles against the flat section of phantom.

4.3 Tissue Simulants

Recommended values for the dielectric parameters of the tissue simulants are given in IEEE 1528 - 2003 and FCC Supplement C to OET Bulletin 65. All tests were carried out using simulants whose dielectric parameters were within \pm 5% of the recommended values. All tests were carried out within 24 hours of measuring the dielectric parameters.

The depth of the tissue simulant was 15.0 \pm 0.5 cm measured from the ear reference point during system checking and device measurements.

4.3.1 Tissue Simulant Recipes

The following recipe(s) were used for Head and Body tissue stimulant(s):

835MHz band

Ingredient	Head (% by weight)	Body (% by weight)
Water	41.45	52.50
Sugar	56.00	45.0
Nacl	1.45	1.40
Cellulose	1.0	1.0
Preventol	0.1	0.10

1900MHz band

Ingredient	Head (% by weight)	Body (% by weight)
Water	44,45	70.17
DGBE	55.24	29.44
Nacl	0.31	0.39

4.3.2 System Checking

The manufacturer calibrates the probes annually. Dielectric parameters of the tissue simulants were measured every day using the dielectric probe kit and the network analyser. A system check measurement was made following the determination of the dielectric parameters of the simulant, using the dipole validation kit. A power level of 250 mW was supplied to the dipole antenna, which was placed under the flat section of the twin SAM phantom. The system checking results (dielectric parameters and SAR values) are given in the table below. Test Date is 2011.3.22

System checking, head tissue simulant

		SAR _{1g} [w/kg]	ϵ_r	σ [S/m]	Temperature	
					Ambient[°C]	Liquid[°C]
900MHz	Target Value	10.8	41.5±2.1	0.97±0.05	15-30	-
	Measured Value	10.9	41.5	0.98	24.0	22.3

All SAR values are normalized to 1W forward power

		SAR _{1g} [w/kg]	ϵ_r	σ [S/m]	Temperature	
					Ambient[°C]	Liquid[°C]
1800MHz	Target Value	38.1	40±1.9	1.40±0.07	15-30	-
	Measured Value	38.8	39.4	1.35	24.0	22.3

All SAR values are normalized to 1W forward power

Plots of the system checking scans are given in Appendix A.

4.3.3 Tissue Simulants used in the Measurements

For the measurement of the following parameters the HP 85070D dielectric probe kit is used, representing the open-ended coaxial probe measurement procedure. Liquid temperature during the test: 22.3° C. Tested date is 2011.3.22

Head		ϵ_r	σ [S/m]	Temperature	
				Ambient [°C]	Liquid [°C]
850MHz	Recommended Value	41.5±2.1	0.97±0.05	15-30	-
	Measured Value	41.5	0.98	24.0	22.3
1900MHz	Recommended Value	40±1.9	1.40±0.07	15-30	-
	Measured Value	39.0	1.44	24.0	22.3

Body		ϵ_r	σ [S/m]	Temperature	
				Ambient [°C]	Liquid [°C]
850MHz	Recommended Value	55.0±2.8	1.05±0.05	15-30	-
	Measured Value	54.6	1.00	24.0	22.3
1900MHz	Recommended Value	53.3±2.7	1.52±0.08	15-30	-
	Measured Value	54.6	1.49	24.0	22.3

5. DESCRIPTION OF THE TEST PROCEDURE

5.1 Device Holder

The device was placed in the device holder (illustrated below) that is supplied by SPEAG as an integral part of the Dasy system.



Device holder supplied by SPEAG

5.2 Test positions

5.2.1 Against Phantom Head

Measurements were made in “cheek” and “tilt” positions on both the left hand and right hand sides of the phantom.

The positions used in the measurements were according to IEEE 1528 - 2003 "IEEE

Recommended Practice for Determining the Peak Spatial-Average Specific Absorption Rate (SAR) in the Human Head from Wireless Communications Devices: Measurement Techniques".

5.2.2 Body Worn Configuration

The device was placed in the SPEAG holder below the flat section of the phantom. The distance between the device and the phantom was kept at the separation distance using a separate flat spacer that was removed before the start of the measurements. And the distance is 1.5cm. The device was oriented with its antenna facing the phantom since this orientation gives higher results.

5.3 Scan Procedure

First, area scans were used for determination of the field distribution and the approximate location of the local peak SAR values. The SAR distribution is scanned along the inside surface, at least for an area larger than the projection of the handset and antenna. The angle between the probe axis and the surface normal line is recommended but not required to be less than 30°. The SAR distribution is first measured on a 2-D coarse grid. The scan region should cover all areas that are exposed and encompassed by the projection of the handset. It is a 15 mm × 15 mm measurement grid used when two staggered one-dimensional cubic splines are used to estimate the maximum SAR location. Next, a zoom scan, a minimum of 7 x 7x7 points covering a volume of at least 30x30x30mm, was performed around the highest E-field value to determine the averaged SAR value. Drift was determined by measuring the same point at the start of the area scan and again at the end of the zoom scan.

5.4 SAR Averaging Methods

The maximum SAR value was averaged over a cube of tissue using interpolation and extrapolation.

The interpolation, extrapolation and maximum search routines within Dasy4 are all based on the modified Quadratic Shepard's method (Robert J. Renka, "Multivariate Interpolation Of Large Sets Of Scattered Data", University of North Texas ACM Transactions on Mathematical Software, vol. 14, no. 2, June 1988, pp. 139-148).

The interpolation scheme combines a least-square fitted function method with a weighted average method. A trivariate 3-D / bivariate 2-D quadratic function is computed for each measurement point and fitted to neighbouring points by a least-square method. For the zoom scan, inverse distance weighting is incorporated to fit distant points more accurately. The interpolating function is finally calculated as a weighted average of the quadratics.

In the zoom scan, the interpolation function is used to extrapolate the Peak SAR from the deepest measurement points to the inner surface of the phantom.

6. MEASUREMENT UNCERTAINTY

DASY4 Uncertainty Budget								
Error description	Uncertainty value	Prob. Dist.	Div.	(c_i) 1g	(c_i) 10g	Std.Unc (1g).	Std.Unc. (10g)	(v_i) V_{eff}
Measurement system								
Probe calibration	±5.9%	N	1	1	1	±5.9%	±5.9%	∞
Axial isotropy	±4.7%	R	$\sqrt{3}$	0.7	0.7	±1.9%	±1.9%	∞
Hemispherical isotropy	±9.6%	R	$\sqrt{3}$	0.7	0.7	±3.9%	±3.9%	∞
Boundary effects	±1.0%	R	$\sqrt{3}$	1	1	±0.6%	±0.6%	∞
Linearity	±4.7%	R	$\sqrt{3}$	1	1	±2.7%	±2.7%	∞
System detection limits	±1.0%	R	$\sqrt{3}$	1	1	±0.6%	±0.6%	∞
Readout electronics	±0.3%	N	1	1	1	±0.3%	±0.3%	∞
Response time	±0.8%	R	$\sqrt{3}$	1	1	±0.5%	±0.5%	∞
Integration time	±2.6%	R	$\sqrt{3}$	1	1	±1.5%	±1.5%	∞
RF ambient noise	±3.0%	R	$\sqrt{3}$	1	1	±1.7%	±1.7%	∞
RF ambient reflections	±3.0%	R	$\sqrt{3}$	1	1	±1.7%	±1.7%	∞
Probe positioner	±0.4%	R	$\sqrt{3}$	1	1	±0.2%	±0.2%	∞
Probe positioning	±2.9%	R	$\sqrt{3}$	1	1	±1.7%	±1.7%	∞
Max.SAR Eval.	±1.0%	R	$\sqrt{3}$	1	1	±0.6%	±0.6%	∞
Test Sample Related								
Device Positioning	±2.9%	N	1	1	1	±2.9%	±2.9%	145
Device holder	±3.6%	N	1	1	1	±3.6%	±3.6%	5
Power drift	±5.0%	R	$\sqrt{3}$	1	1	±2.9%	±2.9%	∞
Phantom and Setup								
Phantom uncertainty	±4.0%	R	$\sqrt{3}$	1	1	±2.3%	±2.3%	∞
Liquid conductivity(target)	±5.0%	R	$\sqrt{3}$	0.64	0.43	±1.8%	±1.2%	∞
Liquid conductivity(meas.)	±2.5%	N	1	0.64	0.43	±1.6%	±1.1%	∞
Liquid conductivity(target)	±5.0%	R	$\sqrt{3}$	0.6	0.49	±1.7%	±1.4%	∞
Liquid onductivity(means.)	±2.5%	N	1	0.6	0.49	±1.5%	±1.2%	∞
Combined std. Uncertainty						±10.9%	±10.7%	387
Expanded STD Uncertainty						±21.9%	±21.4%	

Table 6.1 – Measurement uncertainty evaluation

7. RESULTS

7.1 Test result

In order to determine the largest value of the peak spatial-average SAR of a handset, all device positions, configurations, and operational modes should be tested for each frequency band according to Steps 1 to 3 below.

Step 1: The tests should be performed at the channel that is closest to the center of the transmit frequency band.

Step 2: For the condition providing the highest peak spatial-average SAR determined in Step 1 for each frequency, perform all tests at all other test frequency channels, e.g., lowest and highest frequencies. In addition, for all other conditions (device position, configuration, and operational mode) where the peak spatial-average SAR value determined in Step 1 is within 3 dB of the applicable SAR limit, it is recommended that all other test frequencies should be tested as well.

Step 3: Examine all data to determine the largest value of the peak

The measured Head/body SAR values for the test device are tabulated below:

Mode: GSM 850

f_L (MHz)=824.2MHz

f_M (MHz)=836.4 MHz

f_H (MHz)= 848.8MHz

SAR Values (Head, 850MHz Band)

Limit of SAR (W/kg)	1 g Average
	1.6
Test Case	Measurement Result (mW/g)
	1g Average
Left hand, Touch cheek, f_H	0.989
Left hand, Touch cheek, f_M	1.06
Left hand, Touch cheek, f_L	1.11
Left hand, Tilt 15 Degree, f_H	0.643
Left hand, Tilt 15 Degree, f_M	0.61
Left hand, Tilt 15 Degree, f_L	0.81
Right hand, Touch cheek, f_H	1.09
Right hand, Touch cheek, f_M	1.2
Right hand, Touch cheek, f_L	1.18
Right hand, Tilt 15 Degree, f_H	0.601
Right hand, Tilt 15 Degree, f_M	0.61
Right hand, Tilt 15 Degree, f_L	0.636

So, the maximum SAR is

Phantom Configuration	Device Test Position	SAR(mW/g)/ (10g/1g)		
		f _L (MHz)	f _M (MHz)	f _H (MHz)
Right Side	Cheek	---	1.2	---

Mode: GSM850 (GSM/GPRS/EDGE)

f_L(MHz)=824.2MHz

f_M(MHz)=836.4 MHz

f_H(MHz)= 848.8MHz

SAR Values (body, 850MHz Band)

Limit of SAR (W/kg)	1 g Average	
	1.6	
Test Case	Measurement Result (mW/g)	
	1 g Average	
Towards ground/GSM, with headset 15mm spacer f _H	0.907	
Towards ground/GSM, with headset 15mm spacer f _M	0.811	
Towards ground/GSM, with headset 15mm spacer f _L	0.702	
Towards phantom/GSM, with headset 15mm spacer f _M	0.701	
Towards ground/GPRS, 15mm spacer f _H	0.971	
Towards ground/GPRS, 15mm spacer f _M	0.976	
Towards ground/GPRS, 15mm spacer f _L	0.930	
Towards phantom/GPRS, 15mm spacer f _H	1.040	
Towards phantom/GPRS, 15mm spacer f _M	0.990	
Towards phantom/GPRS, 15mm spacer f _L	0.931	
Towards ground/EGPRS, 15mm spacer f _H	0.450	
Towards ground/EGPRS, 15mm spacer f _M	0.414	
Towards ground/EGPRS, 15mm spacer f _L	0.423	
Towards phantom/EGPRS, 15mm spacer f _H	0.746	
Towards phantom/EGPRS, 15mm spacer f _M	0.796	
Towards phantom/EGPRS, 15mm spacer f _L	0.865	

During the body testing GPRS/EDGE work at the “4Downlink1uplink”, at this Tx slot RF power is larger than other Tx slots.

So, the maximum SAR is

Phantom Configuration	Device Test Position	SAR(mW/g)		
		f _L (MHz)	f _M (MHz)	f _H (MHz)
Towards Phantom/GPRS	15mm spacer	---	---	1.04

Mode: GSM1900

f_L(MHz)=1850.2MHz f_M(MHz)=1880.0MHz f_H(MHz)=1909.8MHz

SAR Values (Head, 1900MHz Band)

Limit of SAR (W/kg)	1 g Average
	1.6
Test Case	Measurement Result (mW/g)
	1g Average
Left hand, Touch cheek, f _H	0.947
Left hand, Touch cheek, f _M	0.961
Left hand, Touch cheek, f _L	1.03
Left hand, Tilt 15 Degree, f _H	0.325
Left hand, Tilt 15 Degree, f _M	0.334
Left hand, Tilt 15 Degree, f _L	0.354
Right hand, Touch cheek, f _H	0.883
Right hand, Touch cheek, f _M	0.877
Right hand, Touch cheek, f _L	0.918
Right hand, Tilt 15 Degree, f _H	0.311
Right hand, Tilt 15 Degree, f _M	0.306
Right hand, Tilt 15 Degree, f _L	0.323

So, the maximum SAR is

Phantom Configuration	Device Test Position	SAR(mW/g)		
		f _L (MHz)	f _M (MHz)	f _H (MHz)
Left Side	Cheek	1.03	---	---

Mode: GSM1900 (GSM/GPRS/EDGE)

f_L (MHz)=1850.2MHz f_M (MHz)=1880.0MHz f_H (MHz)=1909.8MHz

SAR Values (body, 1900MHz Band)

Limit of SAR (W/kg)	1 g Average	
	1.6	
Test Case	Measurement Result (mW/g)	
	1 g Average	
Towards ground/GSM, with headset 15mm spacer f_H	0.625	
Towards ground/GSM, with headset 15mm spacer f_M	0.401	
Towards ground/GSM, with headset 15mm spacer f_L	0.559	
Towards phantom/GSM, with headset 15mm spacer f_M	0.335	
Towards ground/GPRS, 15mm spacer f_H	0.804	
Towards ground/GPRS, 15mm spacer f_M	0.721	
Towards ground/GPRS, 15mm spacer f_L	0.700	
Towards phantom/GPRS, 15mm spacer f_M	0.326	
Towards ground/EGPRS, 15mm spacer f_H	0.310	
Towards ground/EGPRS, 15mm spacer f_M	0.293	
Towards ground/EGPRS, 15mm spacer f_L	0.288	
Towards phantom/EGPRS, 15mm spacer f_M	0.305	

During the body testing GPRS/EDGE work at the “4Downlink1uplink”, at this Tx slot RF power is larger than other Tx slots.

So, the maximum SAR is

Phantom Configuration	Device Test Position	SAR(mW/g)		
		f_L (MHz)	f_M (MHz)	f_H (MHz)
Towards ground/GPRS	15mm spacer	---	---	0.804

Mode: WCDMA B5

f_L (MHz)=826.4MHz f_M (MHz)=836.4MHz f_H (MHz)= 846.6MHz

SAR Values (Head, WCDMA B5)

Limit of SAR (W/kg)	1 g Average	
	1.6	
Test Case	Measurement Result (mW/g)	
	1 g Average	
Left hand, Touch cheek ,	f_H	0.801
Left hand, Touch cheek,	f_M	0.735
Left hand, Touch cheek ,	f_L	0.767
Left hand, Tilt 15 Degree,	f_H	0.437
Left hand, Tilt 15 Degree,	f_M	0.455
Left hand, Tilt 15 Degree,	f_L	0.350
Right hand, Touch cheek,	f_H	0.813
Right hand, Touch cheek,	f_M	0.729
Right hand, Touch cheek,	f_L	0.631
Right hand, Tilt 15 Degree	f_H	0.408
Right hand, Tilt 15 Degree	f_M	0.363
Right hand, Tilt 15 Degree,	f_L	0.399

So, the maximum SAR is

Phantom Configuration	Device Test Position	SAR(mW/g)		
		f_L (MHz)	f_M (MHz)	f_H (MHz)
Right Side	Cheek	---	---	0.813

Mode: WCDMA B5

$f_L(\text{MHz})=826.4\text{MHz}$ $f_M(\text{MHz})=836.4\text{MHz}$ $f_H(\text{MHz})= 846.6\text{MHz}$

SAR Values (body, WCDMA B5)

Limit of SAR (W/kg)	1 g Average
	1.6
Test Case	Measurement Result (mW/g)
	1 g Average
Towards ground, 15mm spacer with headset f_H	0.742
Towards ground, 15mm spacer with headset f_M	0.847
Towards ground, 15mm spacer with headset f_L	0.620
Towards phantom, 15mm spacer with headset f_M	0.555

So, the maximum SAR is

Phantom Configuration	Device Test Position	SAR(mW/g)		
		$f_L(\text{MHz})$	$f_M(\text{MHz})$	$f_H(\text{MHz})$
Towards ground	with headset 15mm spacer	---	0.847	---

Mode: WCDMA B2

f_L (MHz)=1852.4MHz f_M (MHz)=1880MHz f_H (MHz)= 1907.6MHz

SAR Values (Head, WCDMA B2)

Limit of SAR (W/kg)	1 g Average	
	1.6	
Test Case	Measurement Result (mW/g)	
	1 g Average	
Left hand, Touch cheek , f_H	0.822	
Left hand, Touch cheek, f_M	0.972	
Left hand, Touch cheek , f_L	1.07	
Left hand, Tilt 15 Degree, f_H	0.655	
Left hand, Tilt 15 Degree, f_M	0.686	
Left hand, Tilt 15 Degree, f_L	0.748	
Right hand, Touch cheek, f_H	1.03	
Right hand, Touch cheek, f_M	1.0	
Right hand, Touch cheek, f_L	1.23	
Right hand, Tilt 15 Degree f_H	0.684	
Right hand, Tilt 15 Degree f_M	0.583	
Right hand, Tilt 15 Degree, f_L	0.57	

So, the maximum SAR is

Phantom Configuration	Device Test Position	SAR(mW/g)		
		f_L (MHz)	f_M (MHz)	f_H (MHz)
Right Side	cheek	1.23	---	---

Mode: WCDMA B2

f_L (MHz)=1852.4MHz f_M (MHz)=1880MHz f_H (MHz)= 1907.6MHz

SAR Values (body, WCDMA B2)

Limit of SAR (W/kg)	1 g Average	
	1.6	
Test Case	Measurement Result (mW/g)	
	1 g Average	
Towards ground, with headset 15mm spacer	f_H	0.804
Towards ground, with headset 15mm spacer	f_M	0.963
Towards ground, with headset 15mm spacer	f_L	1.02
Towards phantom, with headset 15mm spacer	f_M	0.678

So, the maximum SAR is

Phantom Configuration	Device Test Position	SAR(mW/g)		
		f_L (MHz)	f_M (MHz)	f_H (MHz)
Towards ground	with headset 15mm spacer	1.02	---	---

7.2 Conducted power

Mode	GSM850(Head) Duty cycle: 1:8(12.5%)			GSM1900(Head) Duty cycle: 1:8(12.5%)		
	128	189	251	512	661	810
Channel	128	189	251	512	661	810
Frequency(MHz)	824.2	836.4	848.8	1850.2	1880.0	1909.8
Measured Power(dBm)	33.05	32.71	32.67	29.56	29.60	29.68

Mode	GPRS850 Duty cycle: 1:4(25%)			GPRS1900 Duty cycle: 1:4(25%)		
	EDGE850 Duty cycle: 1:2(50%)			EDGE1900 Duty cycle: 1:2(50%)		
Channel	128	189	251	512	661	810
Frequency(MHz)	824.2	836.4	848.8	1850.2	1880.0	1909.8
4Downlink1uplink Power(dBm)	33.0	32.66	32.64	29.56	29.60	29.69
	26.77	26.79	26.75	25.42	25.47	25.50
3Downlink2uplink Power(dBm)	31.17	32.82	30.81	27.70	27.73	27.82
	25.40	25.34	25.32	24.11	24.13	24.16
2Downlink3uplink Power(dBm)	30.04	30.06	30.06	26.98	27.01	27.10
	24.41	24.38	24.34	23.16	23.11	23.15
1Downlink4uplink Power(dBm)	28.17	27.82	27.80	24.75	24.76	24.86
	22.00	21.94	21.93	20.68	20.70	20.72

Duty cycle: 1 (100%)

Mode	WCDMA B2 (12.2 kbps RMC)			WCDMA B5 (12.2 kbps RMC)		
Channel	9262	9400	9538	4132	4183	4233
Frequency(MHz)	1852.4	1880	1907.6	826.4	836.5	846.6
Measured Power(dBm)	23.44	23.47	23.26	23.33	23.45	23.05

7.3 Summary of Measurement Results (Bluetooth)

The distance between BT antenna and GSM antenna is $>5\text{cm}$. The location of the antennas inside mobile phone is shown below:

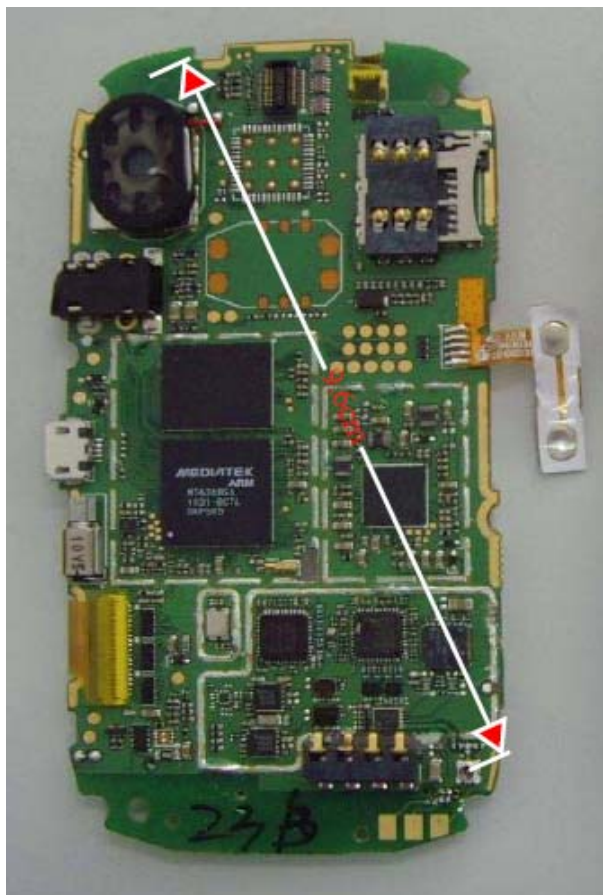

The output power of BT antenna is as following:

According to the output power measurement result and the distance between the two antennas, we can draw the conclusion that: stand-alone SAR and simultaneous transmission SAR are not required for BT transmitter, because the output power of BT transmitter is $\leq 2P_{\text{Ref}}$ and its antenna is $>5\text{cm}$ from other antenna.

APPENDIX A: SYSTEM CHECKING SCANS

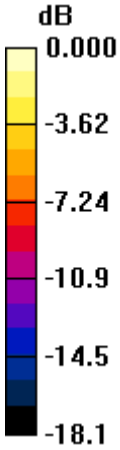
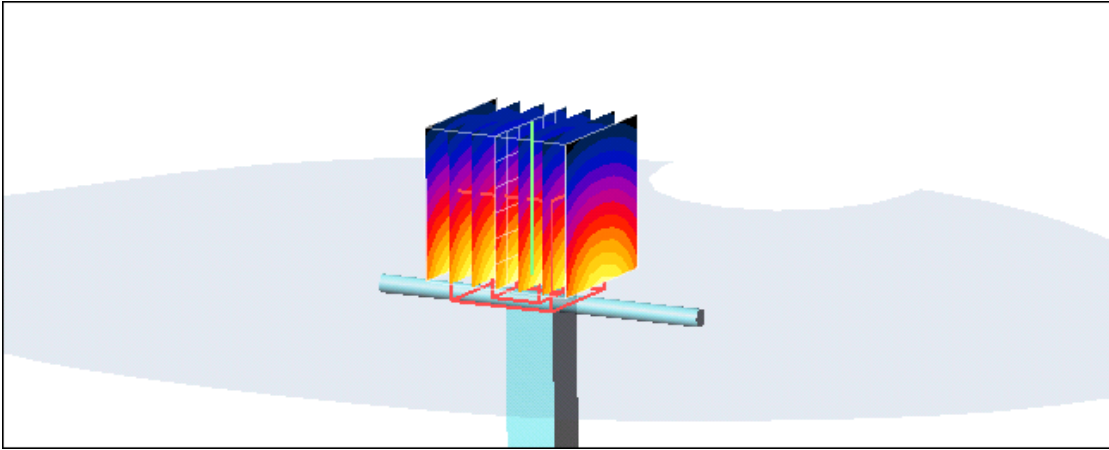
SYSTEM CHECKING SCANS	900MHz
<p>DUT: Dipole 900 MHz; Type: D900V2; Serial: D900V2 - SN:171 Medium parameters used (interpolated): $f = 900 \text{ MHz}$; $\sigma = 0.95 \text{ mho/m}$; $\epsilon_r = 40.7$; $\rho = 1000 \text{ kg/m}^3$</p> <p>DASY4 Configuration:</p> <ul style="list-style-type: none"> - Probe: ES3DV3 - SN3128; ConvF(9.03, 9.53, 9.2); Calibrated: 6/22/2010 - Sensor-Surface: 4mm (Mechanical Surface Detection) - Electronics: DAE4 - SN720; Calibrated: 1/19/2011 - Phantom: SAM 1560; Type: SAM; Serial: 1560 - Measurement SW: DASY4, V4.7 Build 80; Postprocessing SW: SEMCAD, V1.8 Build 186 <p>d=15mm, Pin=250mW/Zoom Scan (7x7x7) (7x7x7)/Cube 0: Measurement grid: $dx=5\text{mm}$, $dy=5\text{mm}$, $dz=5\text{mm}$ Reference Value = 56.3V/m; Power Drift = -0.047 dB Peak SAR (extrapolated) = 4.08 W/kg SAR(1 g) = 2.72 mW/g; SAR(10 g) = 1.62 mW/g Maximum value of SAR (measured) = 2.9 mW/g</p> <div style="display: flex; align-items: center;"> <div style="margin-right: 20px;"> <p>dB</p>  <p>0.000 -3.62 -7.24 -10.9 -14.5 -18.1</p> </div> <div>  </div> </div> <p style="text-align: center;">0 dB = 2.9 mW/g</p>	

SYSTEM CHECKING SCANS

1800 MHz

DUT: Dipole 1800 MHz; Type: D1800V2; Serial: D1800V2 - SN:2d084
Program Name: System Performance Check at 1800 MHz

Communication System: CW; Frequency: 1800 MHz; Duty Cycle: 1:1
 Medium parameters used: $f = 1800$ MHz; $\sigma = 1.35$ mho/m; $\epsilon_r = 39.4$; $\rho = 1000$ kg/m³
 Phantom section: Flat Section

DASY4 Configuration:

- Probe: ES3DV3 - SN3128; ConvF(6.15, 6.5, 6.27); Calibrated: 6/22/2010
- Sensor-Surface: 4mm (Mechanical Surface Detection)
- Electronics: DAE4 - SN720; Calibrated: 1/19/2011
- Phantom: SAM 1559; Type: SAM; Serial: 1559
- Measurement SW: DASY4, V4.7 Build 80; Postprocessing SW: SEMCAD, V1.8 Build 186

d=10mm, Pin=250mW/Zoom Scan (7x7x7) (7x7x7)/Cube 0: Measurement grid: dx=5mm, dy=5mm, dz=5mm

Reference Value = 90.1 V/m; Power Drift = 0.030 dB

Peak SAR (extrapolated) = 17.9 W/kg

SAR(1 g) = 9.71 mW/g; SAR(10 g) = 5.08 mW/g

Maximum value of SAR (measured) = 10.9 mW/g

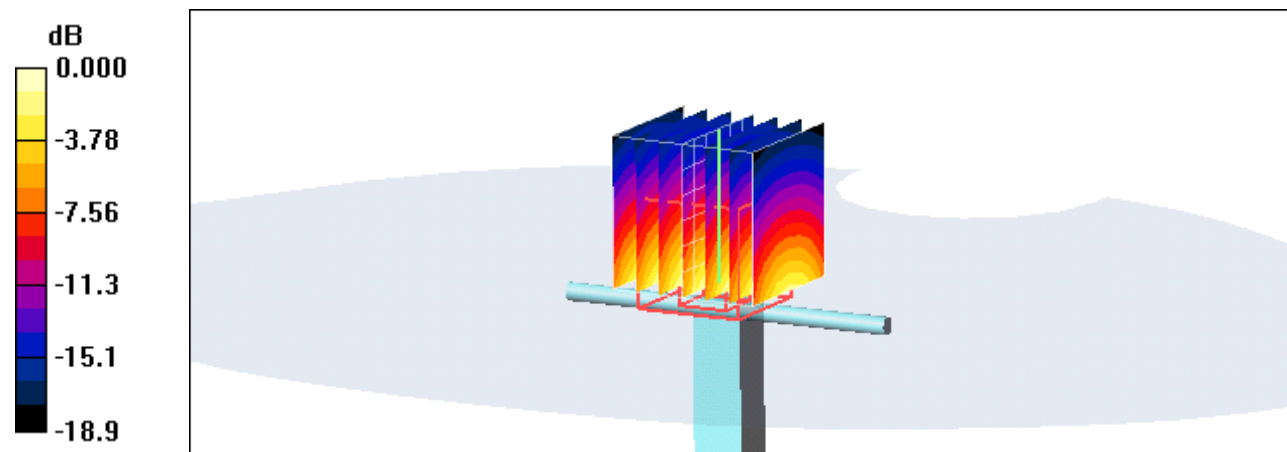

0 dB = 10.9 mW/g

APPENDIX B: MEASUREMENT SCANS

GSM (850MHz/Head)

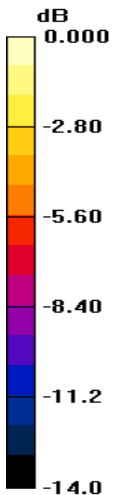
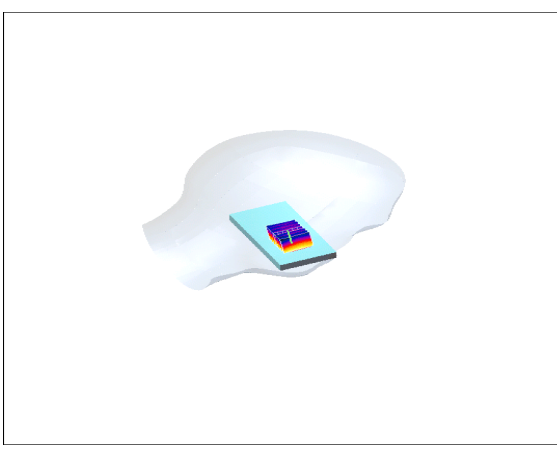
Left Side	Cheek	824.2 MHz
<p>Communication System: GSM 850; Frequency: 824.2 MHz; Duty Cycle: 1:8.3 Medium parameters used (interpolated): $f = 824.2$ MHz; $\sigma = 0.961$ mho/m; $\epsilon_r = 39.6$; $\rho = 1000$ kg/m³ Phantom section: Left Section</p> <p>DASY4 Configuration: - Probe: ES3DV3 - SN3128; ConvF(7.88, 8.3, 8.05); Calibrated: 6/22/2010 - Sensor-Surface: 4mm (Mechanical Surface Detection) - Electronics: DAE4 - SN720; Calibrated: 1/19/2011 - Phantom: SAM 1560; Type: SAM; Serial: 1560 - Measurement SW: DASY4, V4.7 Build 80; Postprocessing SW: SEMCAD, V1.8 Build 186</p> <p>touch position -low/Zoom Scan (7x7x7) (7x7x7)/Cube 0: Measurement grid: dx=5mm, dy=5mm, dz=5mm Reference Value = 13.6 V/m; Power Drift = -0.018 dB Peak SAR (extrapolated) = 1.44 W/kg SAR(1 g) = 1.11 mW/g; SAR(10 g) = 0.807 mW/g</p> <p>Info: Interpolated medium parameters used for SAR evaluation. Maximum value of SAR (measured) = 1.21 mW/g</p> <div style="display: flex; align-items: center;"> <div style="margin-right: 20px;"> <p>dB</p>  <p>0.000 -2.80 -5.60 -8.40 -11.2 -14.0</p> </div> <div style="flex-grow: 1;">  </div> </div> <p style="text-align: center;">0 dB = 1.21mW/g</p>		

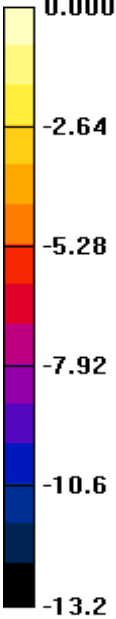
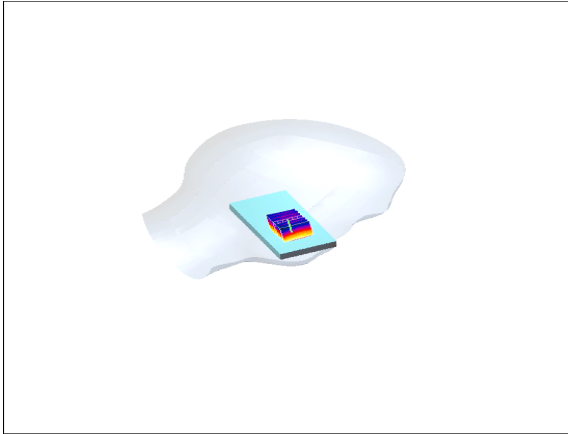
Left Side	Cheek	836.4 MHz
<p>Communication System: GSM 850; Frequency: 836.4 MHz; Duty Cycle: 1:8.3 Medium parameters used (interpolated): $f = 836.4$ MHz; $\sigma = 0.978$ mho/m; $\epsilon_r = 39.4$; $\rho = 1000$ kg/m³ Phantom section: Left Section</p> <p>DASY4 Configuration: - Probe: ES3DV3 - SN3128; ConvF(7.88, 8.3, 8.05); Calibrated: 6/22/2010 - Sensor-Surface: 4mm (Mechanical Surface Detection) - Electronics: DAE4 - SN720; Calibrated: 1/19/2011 - Phantom: SAM 1560; Type: SAM; Serial: 1560 - Measurement SW: DASY4, V4.7 Build 80; Postprocessing SW: SEMCAD, V1.8 Build 186</p> <p>Touch position - Middle/Zoom Scan (7x7x7) (7x7x7)/Cube 0: Measurement grid: dx=5mm, dy=5mm, dz=5mm Reference Value = 13.6 V/m; Power Drift = -0.212 dB Peak SAR (extrapolated) = 1.37 W/kg SAR(1 g) = 1.06 mW/g; SAR(10 g) = 0.772 mW/g Maximum value of SAR (measured) = 1.14 mW/g</p>		
<div style="display: flex; align-items: center;"> <div style="margin-right: 20px;"> <p>dB</p> <p>0.000</p>  <p>-2.64</p> <p>-5.28</p> <p>-7.92</p> <p>-10.6</p> <p>-13.2</p> </div> <div style="text-align: center;">  <p>0 dB = 1.14mW/g</p> </div> </div>		

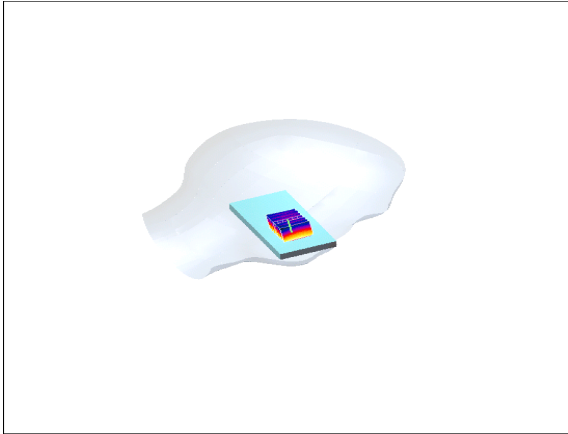
Left Side	Cheek	848.8 MHz
<p>Communication System: GSM 850; Frequency: 848.8 MHz; Duty Cycle: 1:8.3 Medium parameters used (interpolated): $f = 848.8$ MHz; $\sigma = 0.987$ mho/m; $\epsilon_r = 40.3$; $\rho = 1000$ kg/m³ Phantom section: Left Section</p> <p>DASY4 Configuration: - Probe: ES3DV3 - SN3128; ConvF(7.88, 8.3, 8.05); Calibrated: 6/22/2010 - Sensor-Surface: 4mm (Mechanical Surface Detection) - Electronics: DAE4 - SN720; Calibrated: 1/19/2011 - Phantom: SAM 1560; Type: SAM; Serial: 1560 - Measurement SW: DASY4, V4.7 Build 80; Postprocessing SW: SEMCAD, V1.8 Build 186</p> <p>touch position-high/Zoom Scan (7x7x7) (7x7x7)/Cube 0: Measurement grid: dx=5mm, dy=5mm, dz=5mm Reference Value = 12.8 V/m; Power Drift = 0.025 dB Peak SAR (extrapolated) = 1.27 W/kg SAR(1 g) = 0.989 mW/g; SAR(10 g) = 0.721 mW/g Maximum value of SAR (measured) = 1.05 mW/g</p>		
<div style="display: flex; align-items: center;"> <div style="margin-right: 20px;"> <p>dB</p> <p>0.000</p> <p>-2.90</p> <p>-5.80</p> <p>-8.70</p> <p>-11.6</p> <p>-14.5</p> </div> <div style="text-align: center;">  <p>0 dB = 1.05mW/g</p> </div> </div>		

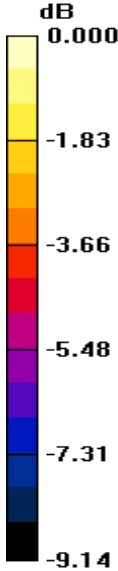
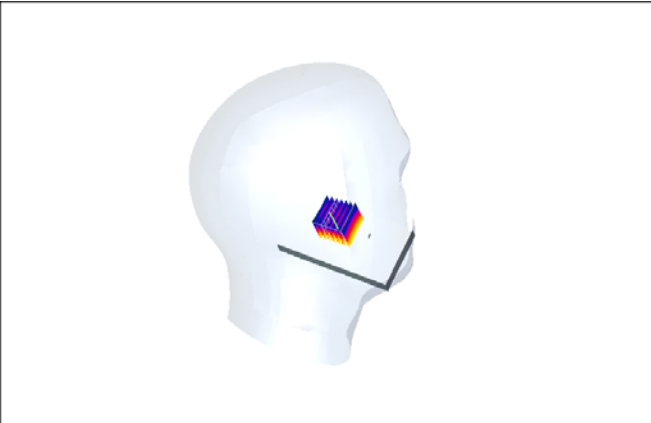
Left Side	Tilt	836.4 MHz
<p>Communication System: GSM 850; Frequency: 836.4 MHz; Duty Cycle: 1:8.3 Medium parameters used (interpolated): $f = 836.4$ MHz; $\sigma = 0.978$ mho/m; $\epsilon_r = 39.4$; $\rho = 1000$ kg/m³ Phantom section: Left Section</p> <p>DASY4 Configuration: - Probe: ES3DV3 - SN3128; ConvF(7.88, 8.3, 8.05); Calibrated: 6/22/2010 - Sensor-Surface: 4mm (Mechanical Surface Detection) - Electronics: DAE4 - SN720; Calibrated: 1/19/2011 - Phantom: SAM 1560; Type: SAM; Serial: 1560 - Measurement SW: DASY4, V4.7 Build 80; Postprocessing SW: SEMCAD, V1.8 Build 186</p> <p>Tilt position - Middle/Zoom Scan (7x7x7) (7x7x7)/Cube 0: Measurement grid: dx=5mm, dy=5mm, dz=5mm Reference Value = 20.9 V/m; Power Drift = 0.100 dB Peak SAR (extrapolated) = 0.781 W/kg SAR(1 g) = 0.610 mW/g; SAR(10 g) = 0.450 mW/g Maximum value of SAR (measured) = 0.650 mW/g</p> <div style="display: flex; align-items: center;"> <div style="margin-right: 20px;"> <p>dB</p>  </div> <div style="text-align: center;">  </div> </div> <p style="text-align: center;">0 dB = 0.650mW/g</p>		

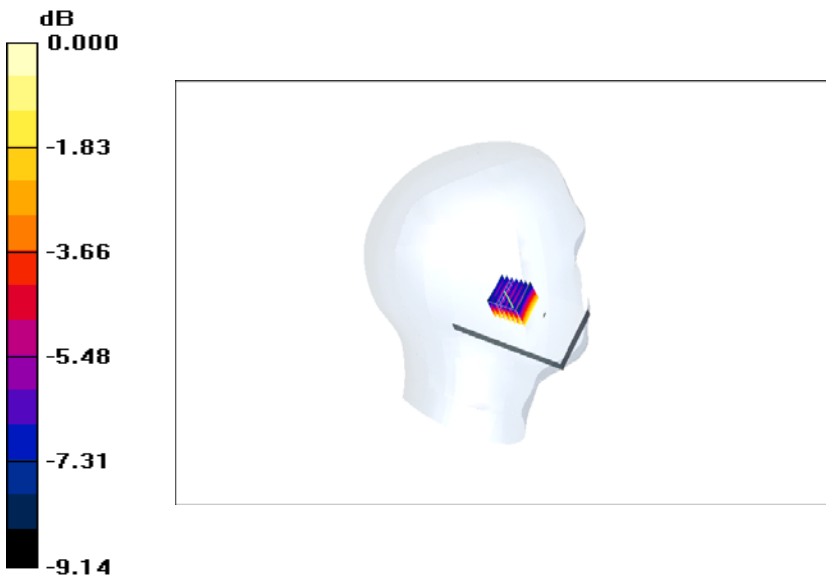
Left Side	Tilt	824.2 MHz
<p>Communication System: GSM 850; Frequency: 824.2 MHz; Duty Cycle: 1:8.3 Medium parameters used (interpolated): $f = 824.2$ MHz; $\sigma = 0.961$ mho/m; $\epsilon_r = 39.6$; $\rho = 1000$ kg/m³ Phantom section: Left Section</p> <p>DASY4 Configuration: - Probe: ES3DV3 - SN3128; ConvF(7.88, 8.3, 8.05); Calibrated: 6/22/2010 - Sensor-Surface: 4mm (Mechanical Surface Detection) - Electronics: DAE4 - SN720; Calibrated: 1/19/2011 - Phantom: SAM 1560; Type: SAM; Serial: 1560 - Measurement SW: DASY4, V4.7 Build 80; Postprocessing SW: SEMCAD, V1.8 Build 186</p> <p>Tilt position/Zoom Scan (7x7x7)/Cube 0: Measurement grid: dx=5mm, dy=5mm, dz=5mm Reference Value = 22.3 V/m; Power Drift = -0.037 dB Peak SAR (extrapolated) = 2.00 W/kg SAR(1 g) = 0.808 mW/g; SAR(10 g) = 0.499 mW/g Maximum value of SAR (measured) = 0.712 mW/g</p>		
 <p>0 dB = 0.712 mW/g</p>		

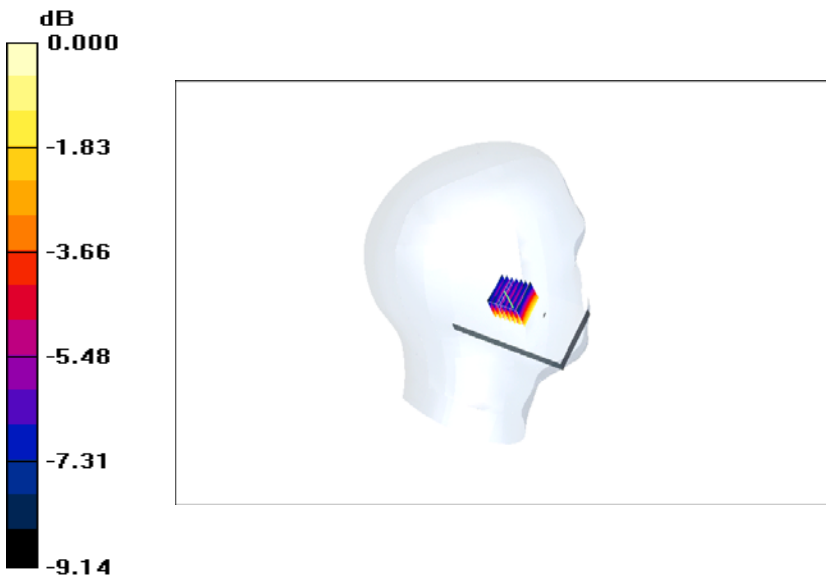
Left Side	Tilt	848.8 MHz
<p>Communication System: GSM 850; Frequency: 848.8 MHz; Duty Cycle: 1:8.3 Medium parameters used (interpolated): $f = 848.8$ MHz; $\sigma = 0.987$ mho/m; $\epsilon_r = 40.3$; $\rho = 1000$ kg/m³ Phantom section: Left Section</p> <p>DASY4 Configuration: - Probe: ES3DV3 - SN3128; ConvF(7.88, 8.3, 8.05); Calibrated: 6/22/2010 - Sensor-Surface: 4mm (Mechanical Surface Detection) - Electronics: DAE4 - SN720; Calibrated: 1/19/2011 - Phantom: SAM 1560; Type: SAM; Serial: 1560 - Measurement SW: DASY4, V4.7 Build 80; Postprocessing SW: SEMCAD, V1.8 Build 186</p> <p>tilt position/Zoom Scan (7x7x7)/Cube 0: Measurement grid: dx=5mm, dy=5mm, dz=5mm Reference Value = 21.9 V/m; Power Drift = -0.221 dB Peak SAR (extrapolated) = 0.814 W/kg SAR(1 g) = 0.643 mW/g; SAR(10 g) = 0.470 mW/g Maximum value of SAR (measured) = 0.693 mW/g</p>		
 <p style="text-align: center;">0 dB = 0.693mW/g</p>		

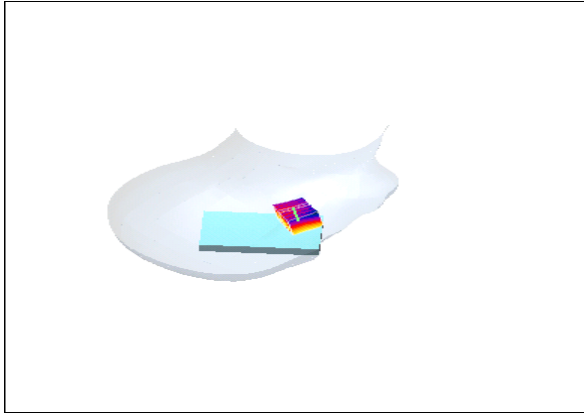
Right Side	Cheek	824.2 MHz
<p>Communication System: GSM 850; Frequency: 824.2 MHz; Duty Cycle: 1:8.3 Medium parameters used (interpolated): $f = 824.2$ MHz; $\sigma = 0.961$ mho/m; $\epsilon_r = 39.6$; $\rho = 1000$ kg/m³ Phantom section: Right Section</p> <p>DASY4 Configuration: - Probe: ES3DV3 - SN3128; ConvF(7.88, 8.3, 8.05); Calibrated: 6/22/2010 - Sensor-Surface: 4mm (Mechanical Surface Detection) - Electronics: DAE4 - SN720; Calibrated: 1/19/2011 - Phantom: SAM 1560; Type: SAM; Serial: 1560 - Measurement SW: DASY4, V4.7 Build 80; Postprocessing SW: SEMCAD, V1.8 Build 186</p> <p>touch low/Zoom Scan (7x7x7) (7x7x7)/Cube 0: Measurement grid: dx=5mm, dy=5mm, dz=5mm Reference Value = 15.9 V/m; Power Drift = -0.125 dB Peak SAR (extrapolated) = 1.66 W/kg SAR(1 g) = 1.18 mW/g; SAR(10 g) = 0.841 mW/g Maximum value of SAR (measured) = 1.27 mW/g</p> <div style="display: flex; align-items: center;"> <div style="margin-right: 20px;"> <p>dB</p> <p>0.000</p> <p>-2.16</p> <p>-4.32</p> <p>-6.48</p> <p>-8.64</p> <p>-10.8</p> </div> <div style="text-align: center;">  </div> </div> <p style="text-align: center;">0 dB = 1.27mW/g</p>		

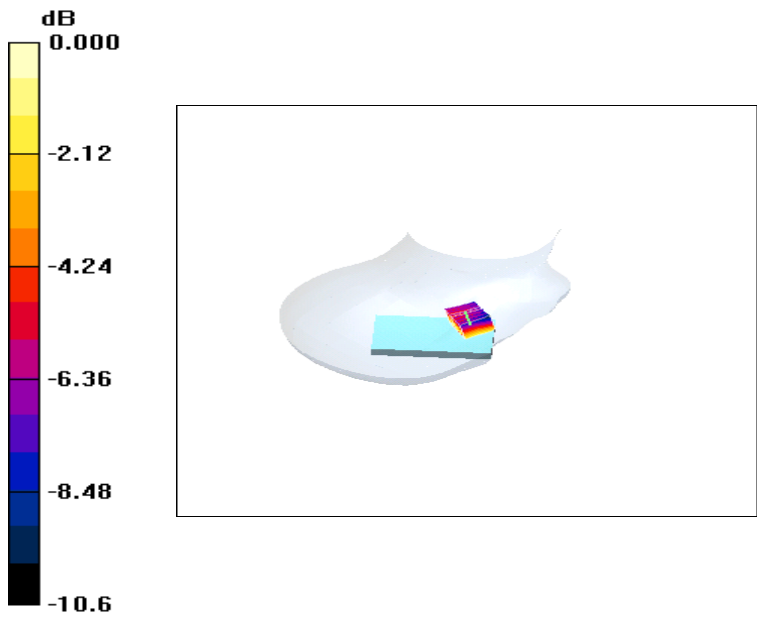
Right Side	Cheek	836.4 MHz
<p>Communication System: GSM 850; Frequency: 836.4 MHz; Duty Cycle: 1:8.3 Medium parameters used (interpolated): $f = 836.4 \text{ MHz}$; $\sigma = 0.978 \text{ mho/m}$; $\epsilon_r = 39.4$; $\rho = 1000 \text{ kg/m}^3$ Phantom section: Right Section</p> <p>DASY4 Configuration: - Probe: ES3DV3 - SN3128; ConvF(7.88, 8.3, 8.05); Calibrated: 6/22/2010 - Sensor-Surface: 4mm (Mechanical Surface Detection) - Electronics: DAE4 - SN720; Calibrated: 1/19/2011 - Phantom: SAM 1560; Type: SAM; Serial: 1560 - Measurement SW: DASY4, V4.7 Build 80; Postprocessing SW: SEMCAD, V1.8 Build 186</p> <p>Touch position - Middle/Zoom Scan (7x7x7) (7x7x7)/Cube 0: Measurement grid: $dx=5\text{mm}$, $dy=5\text{mm}$, $dz=5\text{mm}$ Reference Value = 14.5 V/m; Power Drift = 0.070 dB Peak SAR (extrapolated) = 1.54 W/kg SAR(1 g) = 1.2 mW/g; SAR(10 g) = 0.863 mW/g Maximum value of SAR (measured) = 1.27 mW/g</p>		
 <p style="text-align: center;">0 dB = 1.27mW/g</p>		

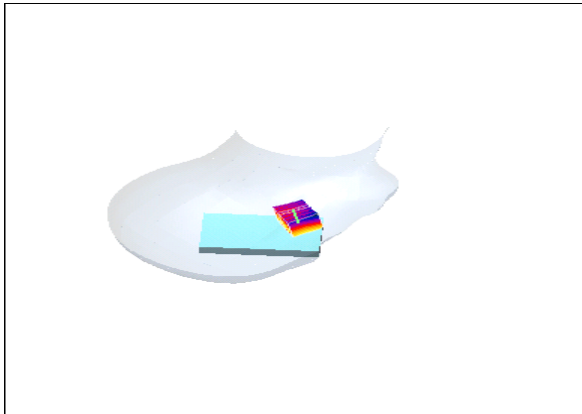
Right Side	Cheek	848.8 MHz
<p>Communication System: GSM 850; Frequency: 848.8 MHz; Duty Cycle: 1:8.3 Medium parameters used (interpolated): $f = 848.8$ MHz; $\sigma = 0.987$ mho/m; $\epsilon_r = 40.3$; $\rho = 1000$ kg/m³ Phantom section: Right Section</p> <p>DASY4 Configuration: - Probe: ES3DV3 - SN3128; ConvF(7.88, 8.3, 8.05); Calibrated: 6/22/2010 - Sensor-Surface: 4mm (Mechanical Surface Detection) - Electronics: DAE4 - SN720; Calibrated: 1/19/2011 - Phantom: SAM 1560; Type: SAM; Serial: 1560 - Measurement SW: DASY4, V4.7 Build 80; Postprocessing SW: SEMCAD, V1.8 Build 186</p> <p>touch high/Zoom Scan (7x7x7) (7x7x7)/Cube 0: Measurement grid: dx=5mm, dy=5mm, dz=5mm Reference Value = 14.3 V/m; Power Drift = 0.049 dB Peak SAR (extrapolated) = 1.37 W/kg SAR(1 g) = 1.09 mW/g; SAR(10 g) = 0.787 mW/g Maximum value of SAR (measured) = 1.16 mW/g</p> <div style="display: flex; align-items: center;"> <div style="margin-right: 20px;"> <p>dB</p> <p>0.000</p> <p>-2.40</p> <p>-4.80</p> <p>-7.20</p> <p>-9.60</p> <p>-12.0</p> </div> <div style="text-align: center;">  </div> </div> <p style="text-align: center;">0 dB = 1.16mW/g</p>		

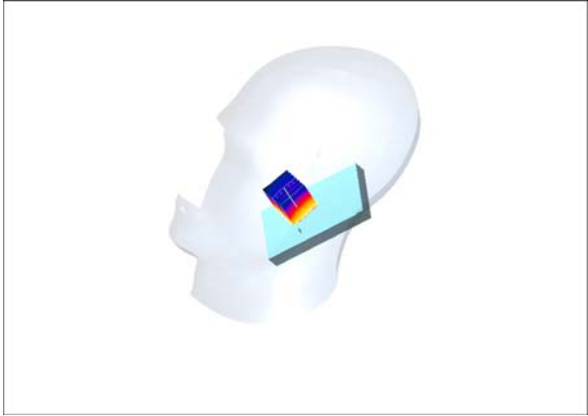
Right Side	Tilt	836.4MHz
<p>Communication System: GSM 850; Frequency: 836.4 MHz; Duty Cycle: 1:8.3 Medium parameters used (interpolated): $f = 836.4$ MHz; $\sigma = 0.978$ mho/m; $\epsilon_r = 39.4$; $\rho = 1000$ kg/m³ Phantom section: Right Section</p> <p>DASY4 Configuration: - Probe: ES3DV3 - SN3128; ConvF(7.88, 8.3, 8.05); Calibrated: 6/22/2010 - Sensor-Surface: 4mm (Mechanical Surface Detection) - Electronics: DAE4 - SN720; Calibrated: 1/19/2011 - Phantom: SAM 1560; Type: SAM; Serial: 1560 - Measurement SW: DASY4, V4.7 Build 80; Postprocessing SW: SEMCAD, V1.8 Build 186</p> <p>Tilt position - Middle/Zoom Scan (7x7x7) (7x7x7)/Cube 0: Measurement grid: $dx=5mm, dy=5mm, dz=5mm$ Reference Value = 20.6 V/m; Power Drift = -0.024 dB Peak SAR (extrapolated) = 0.776 W/kg SAR(1 g) = 0.610 mW/g; SAR(10 g) = 0.454 mW/g Maximum value of SAR (measured) = 0.658 mW/g</p> <div style="display: flex; align-items: center;"> <div style="margin-right: 20px;"> <p>dB</p> <p>0.000</p> <p>-1.80</p> <p>-3.60</p> <p>-5.39</p> <p>-7.19</p> <p>-8.99</p> </div> <div style="text-align: center;">  </div> </div> <p style="text-align: center;">0 dB = 0.658 mW/g</p>		

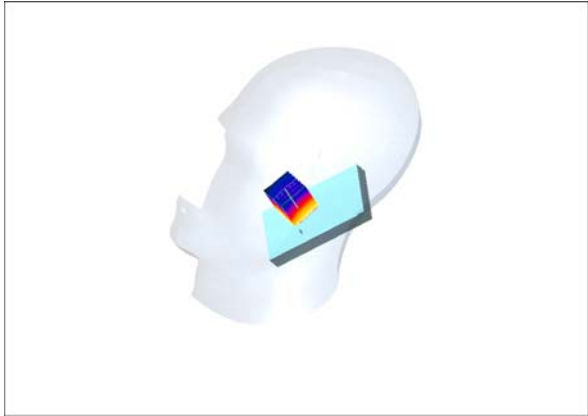
Right Side	Tilt	848.8MHz
<p>Communication System: GSM 850; Frequency: 848.8 MHz; Duty Cycle: 1:8.3 Medium parameters used (interpolated): $f = 848.8$ MHz; $\sigma = 0.987$ mho/m; $\epsilon_r = 40.3$; $\rho = 1000$ kg/m³ Phantom section: Right Section</p> <p>DASY4 Configuration: - Probe: ES3DV3 - SN3128; ConvF(7.88, 8.3, 8.05); Calibrated: 6/22/2010 - Sensor-Surface: 4mm (Mechanical Surface Detection) - Electronics: DAE4 - SN720; Calibrated: 1/19/2011 - Phantom: SAM 1560; Type: SAM; Serial: 1560 - Measurement SW: DASY4, V4.7 Build 80; Postprocessing SW: SEMCAD, V1.8 Build 186</p> <p>tilt position/Zoom Scan (7x7x7)/Cube 0: Measurement grid: dx=5mm, dy=5mm, dz=5mm Reference Value = 19.9 V/m; Power Drift = 0.124 dB Peak SAR (extrapolated) = 0.753 W/kg SAR(1 g) = 0.601 mW/g; SAR(10 g) = 0.444 mW/g Maximum value of SAR (measured) = 0.653 mW/g</p> <div style="display: flex; align-items: center;"> <div style="margin-right: 20px;"> <p>dB</p> <p>0.000</p> <p>-1.80</p> <p>-3.60</p> <p>-5.39</p> <p>-7.19</p> <p>-8.99</p> </div> <div style="flex-grow: 1;">  </div> </div> <p style="text-align: center;">0 dB = 0.653 mW/g</p>		

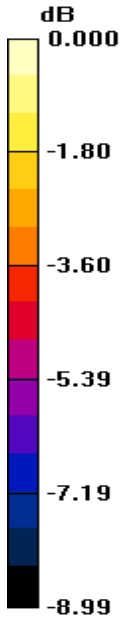
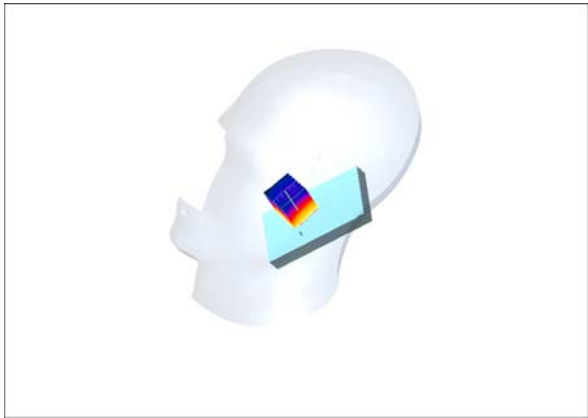
Right Side	Tilt	824.2MHz
<p>Communication System: GSM 850; Frequency: 824.2 MHz; Duty Cycle: 1:8.3 Medium parameters used (interpolated): $f = 824.2 \text{ MHz}$; $\sigma = 0.961 \text{ mho/m}$; $\epsilon_r = 39.6$; $\rho = 1000 \text{ kg/m}^3$ Phantom section: Right Section</p> <p>DASY4 Configuration: - Probe: ES3DV3 - SN3128; ConvF(7.88, 8.3, 8.05); Calibrated: 6/22/2010 - Sensor-Surface: 4mm (Mechanical Surface Detection) - Electronics: DAE4 - SN720; Calibrated: 1/19/2011 - Phantom: SAM 1560; Type: SAM; Serial: 1560 - Measurement SW: DASY4, V4.7 Build 80; Postprocessing SW: SEMCAD, V1.8 Build 186</p> <p>Tilt position/Zoom Scan (7x7x7)/Cube 0: Measurement grid: dx=5mm, dy=5mm, dz=5mm Reference Value = 21.1 V/m; Power Drift = 0.053 dB Peak SAR (extrapolated) = 0.806 W/kg SAR(1 g) = 0.636 mW/g; SAR(10 g) = 0.475 mW/g Maximum value of SAR (measured) = 0.682 mW/g</p> <div style="display: flex; align-items: center;"> <div style="margin-right: 20px;"> <p>dB</p>  <p>0.000 -1.80 -3.60 -5.39 -7.19 -8.99</p> </div> <div style="text-align: center;">  <p>0 dB = 0.682 mW/g</p> </div> </div>		

GSM with headset (850MHz/Flat)

FLAT	Towards ground	836.4 MHz
<p>Communication System: GSM 850; Frequency: 836.4 MHz; Duty Cycle: 1:8.3 Medium parameters used (interpolated): $f = 836.4$ MHz; $\sigma = 0.99$ mho/m; $\epsilon_r = 53.7$; $\rho = 1000$ kg/m³ Phantom section: Flat Section</p> <p>DASY4 Configuration: - Probe: ES3DV3 - SN3128; ConvF(6.78, 7.02, 6.8); Calibrated: 6/22/2010 - Sensor-Surface: 4mm (Mechanical Surface Detection) - Electronics: DAE4 - SN720; Calibrated: 1/19/2011 - Phantom: SAM 1560; Type: SAM; Serial: 1560 - Measurement SW: DASY4, V4.7 Build 80; Postprocessing SW: SEMCAD, V1.8 Build 186</p> <p>Towards ground - Middle/Zoom Scan (7x7x7) (7x7x7)/Cube 0: Measurement grid: $dx=5$mm, $dy=5$mm, $dz=5$mm Reference Value = 25.2 V/m; Power Drift = -0.213 dB Peak SAR (extrapolated) = 1.07 W/kg SAR(1 g) = 0.811 mW/g; SAR(10 g) = 0.590 mW/g Maximum value of SAR (measured) = 0.863 mW/g</p> <div data-bbox="140 1299 1173 1848"> </div> <p>0 dB = 0.863mW/g</p>		

FLAT	Towards ground	824.2 MHz
<p>Communication System: GSM 850; Frequency: 824.2 MHz; Duty Cycle: 1:8.3 Medium parameters used: $f = 825$ MHz; $\sigma = 0.968$ mho/m; $\epsilon_r = 53.1$; $\rho = 1000$ kg/m³ Phantom section: Flat Section</p> <p>DASY4 Configuration: - Probe: ES3DV3 - SN3128; ConvF(6.78, 7.02, 6.8); Calibrated: 6/22/2010 - Sensor-Surface: 4mm (Mechanical Surface Detection) - Electronics: DAE4 - SN720; Calibrated: 1/19/2011 - Phantom: SAM 1560; Type: SAM; Serial: 1560 - Measurement SW: DASY4, V4.7 Build 80; Postprocessing SW: SEMCAD, V1.8 Build 186</p> <p>Towards ground - Low/Zoom Scan (7x7x7) (7x7x7)/Cube 0: Measurement grid: dx=5mm, dy=5mm, dz=5mm Reference Value = 23.4 V/m; Power Drift = -0.061 dB Peak SAR (extrapolated) = 0.904 W/kg SAR(1 g) = 0.702 mW/g; SAR(10 g) = 0.511 mW/g Maximum value of SAR (measured) = 0.747 mW/g</p> <div data-bbox="140 1176 1173 1825"> <p>0 dB = 0.747mW/g</p> </div>		

FLAT	Towards ground	848.8MHz
<p>Communication System: GSM 850; Frequency: 848.8 MHz; Duty Cycle: 1:8.3 Medium parameters used (interpolated): $f = 848.8 \text{ MHz}$; $\sigma = 1 \text{ mho/m}$; $\epsilon_r = 54.6$; $\rho = 1000 \text{ kg/m}^3$ Phantom section: Flat Section</p> <p>DASY4 Configuration: - Probe: ES3DV3 - SN3128; ConvF(6.78, 7.02, 6.8); Calibrated: 6/22/2010 - Sensor-Surface: 4mm (Mechanical Surface Detection) - Electronics: DAE4 - SN720; Calibrated: 1/19/2011 - Phantom: SAM 1560; Type: SAM; Serial: 1560 - Measurement SW: DASY4, V4.7 Build 80; Postprocessing SW: SEMCAD, V1.8 Build 186</p> <p>Towards ground-high/Zoom Scan (7x7x7) (7x7x7)/Cube 0: Measurement grid: $dx=5\text{mm}$, $dy=5\text{mm}$, $dz=5\text{mm}$ Reference Value = 25.8 V/m; Power Drift = 0.065 dB Peak SAR (extrapolated) = 1.21 W/kg SAR(1 g) = 0.907 mW/g; SAR(10 g) = 0.658 mW/g Maximum value of SAR (measured) = 0.986 mW/g</p> <div data-bbox="140 1220 1173 1814"> </div>		

FLAT	Towards phantom	836.4 MHz
<p>Communication System: GSM 850; Frequency: 836.4 MHz; Duty Cycle: 1:8.3 Medium parameters used (interpolated): $f = 836.4$ MHz; $\sigma = 0.99$ mho/m; $\epsilon_r = 53.7$; $\rho = 1000$ kg/m³ Phantom section: Flat Section</p> <p>DASY4 Configuration: - Probe: ES3DV3 - SN3128; ConvF(6.78, 7.02, 6.8); Calibrated: 6/22/2010 - Sensor-Surface: 4mm (Mechanical Surface Detection) - Electronics: DAE4 - SN720; Calibrated: 1/19/2011 - Phantom: SAM 1560; Type: SAM; Serial: 1560 - Measurement SW: DASY4, V4.7 Build 80; Postprocessing SW: SEMCAD, V1.8 Build 186</p> <p>Towards phantom - Middle/Zoom Scan (7x7x7) (7x7x7)/Cube 0: Measurement grid: dx=5mm, dy=5mm, dz=5mm Reference Value = 28.5 V/m; Power Drift = -0.066 dB Peak SAR (extrapolated) = 1.02 W/kg SAR(1 g) = 0.701 mW/g; SAR(10 g) = 0.401 mW/g Maximum value of SAR (measured) = 0.756 mW/g</p> <div data-bbox="140 1227 1173 1769"> </div> <p>0 dB = 0.756mW/g</p>		

GSM (850MHz with GPRS/Flat)

FLAT	Towards ground	836.4 MHz
<p>Communication System: GSM 850; Frequency: 836.4 MHz; Duty Cycle: 1:8.3 Medium parameters used (interpolated): $f = 836.4$ MHz; $\sigma = 0.99$ mho/m; $\epsilon_r = 53.7$; $\rho = 1000$ kg/m³ Phantom section: Flat Section</p> <p>DASY4 Configuration: - Probe: ES3DV3 - SN3128; ConvF(6.78, 7.02, 6.8); Calibrated: 6/22/2010 - Sensor-Surface: 4mm (Mechanical Surface Detection) - Electronics: DAE4 - SN720; Calibrated: 1/19/2011 - Phantom: SAM 1560; Type: SAM; Serial: 1560 - Measurement SW: DASY4, V4.7 Build 80; Postprocessing SW: SEMCAD, V1.8 Build 186</p> <p>towards ground - middle GPRS/Zoom Scan (7x7x7) (7x7x7)/Cube 0: Measurement grid: dx=5mm, dy=5mm, dz=5mm Reference Value = 33.4 V/m; Power Drift = -0.321 dB Peak SAR (extrapolated) = 1.34 W/kg SAR(1 g) = 0.976 mW/g; SAR(10 g) = 0.683 mW/g Maximum value of SAR (measured) = 1.07 mW/g</p> <div data-bbox="140 1294 1173 1825"> </div> <p>0 dB = 1.07mW/g</p>		

FLAT	Towards ground	824.2 MHz
<p>Communication System: GSM 850; Frequency: 824.2 MHz; Duty Cycle: 1:8.3 Medium parameters used: $f = 825$ MHz; $\sigma = 0.968$ mho/m; $\epsilon_r = 53.1$; $\rho = 1000$ kg/m³ Phantom section: Flat Section</p> <p>DASY4 Configuration: - Probe: ES3DV3 - SN3128; ConvF(6.78, 7.02, 6.8); Calibrated: 6/22/2010 - Sensor-Surface: 4mm (Mechanical Surface Detection) - Electronics: DAE4 - SN720; Calibrated: 1/19/2011 - Phantom: SAM 1560; Type: SAM; Serial: 1560 - Measurement SW: DASY4, V4.7 Build 80; Postprocessing SW: SEMCAD, V1.8 Build 186</p> <p>towards ground - Low GPRS/Zoom Scan (7x7x7) (7x7x7)/Cube 0: Measurement grid: dx=5mm, dy=5mm, dz=5mm Reference Value = 32.3 V/m; Power Drift = -0.094 dB Peak SAR (extrapolated) = 1.29 W/kg SAR(1 g) = 0.930 mW/g; SAR(10 g) = 0.652 mW/g Maximum value of SAR (measured) = 0.991 mW/g</p> <div data-bbox="140 1176 1173 1814"> <p>dB 0.000 -1.82 -3.64 -5.45 -7.27 -9.09</p> </div> <p>0 dB = 0.991mW/g</p>		

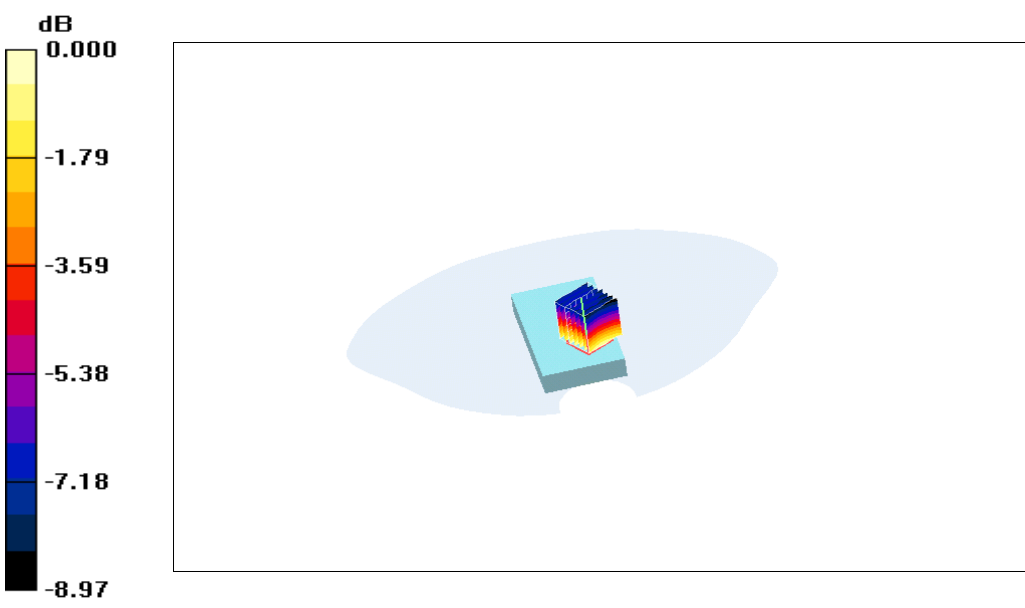
FLAT	Towards ground	848.8MHz
<p>Communication System: GSM 850; Frequency: 848.8 MHz; Duty Cycle: 1:8.3 Medium parameters used (interpolated): $f = 848.8$ MHz; $\sigma = 1$ mho/m; $\epsilon_r = 54.6$; $\rho = 1000$ kg/m³ Phantom section: Flat Section</p> <p>DASY4 Configuration: - Probe: ES3DV3 - SN3128; ConvF(6.78, 7.02, 6.8); Calibrated: 6/22/2010 - Sensor-Surface: 4mm (Mechanical Surface Detection) - Electronics: DAE4 - SN720; Calibrated: 1/19/2011 - Phantom: SAM 1560; Type: SAM; Serial: 1560 - Measurement SW: DASY4, V4.7 Build 80; Postprocessing SW: SEMCAD, V1.8 Build 186</p> <p>towards ground- high GPRS/Zoom Scan (7x7x7) (7x7x7)/Cube 0: Measurement grid: dx=5mm, dy=5mm, dz=5mm Reference Value = 32.1 V/m; Power Drift = -0.097 dB Peak SAR (extrapolated) = 1.34 W/kg SAR(1 g) = 0.971 mW/g; SAR(10 g) = 0.678 mW/g Maximum value of SAR (measured) = 1.03 mW/g</p>		
 <p>0 dB = 1.03 mW/g</p>		

FLAT	Towards phantom	836.4 MHz
<p>Communication System: GSM 850; Frequency: 836.4 MHz; Duty Cycle: 1:8.3 Medium parameters used (interpolated): $f = 836.4$ MHz; $\sigma = 0.99$ mho/m; $\epsilon_r = 53.7$; $\rho = 1000$ kg/m³ Phantom section: Flat Section</p> <p>DASY4 Configuration: - Probe: ES3DV3 - SN3128; ConvF(6.78, 7.02, 6.8); Calibrated: 6/22/2010 - Sensor-Surface: 4mm (Mechanical Surface Detection) - Electronics: DAE4 - SN720; Calibrated: 1/19/2011 - Phantom: SAM 1560; Type: SAM; Serial: 1560 - Measurement SW: DASY4, V4.7 Build 80; Postprocessing SW: SEMCAD, V1.8 Build 186</p> <p>towards phantom - middle GPRS/Zoom Scan (7x7x7) (7x7x7)/Cube 0: Measurement grid: dx=5mm, dy=5mm, dz=5mm Reference Value = 27.4 V/m; Power Drift = -0.025 dB Peak SAR (extrapolated) = 1.30 W/kg SAR(1 g) = 0.990 mW/g; SAR(10 g) = 0.710 mW/g Maximum value of SAR (measured) = 1.05 mW/g</p> <div data-bbox="140 1249 1173 1780"> </div> <p>0 dB = 1.05mW/g</p>		

FLAT	Towards phantom	824.2 MHz
<p>Communication System: GSM 850; Frequency: 824.2 MHz; Duty Cycle: 1:8.3 Medium parameters used: $f = 825$ MHz; $\sigma = 0.968$ mho/m; $\epsilon_r = 53.1$; $\rho = 1000$ kg/m³ Phantom section: Flat Section</p> <p>DASY4 Configuration: - Probe: ES3DV3 - SN3128; ConvF(6.78, 7.02, 6.8); Calibrated: 6/22/2010 - Sensor-Surface: 4mm (Mechanical Surface Detection) - Electronics: DAE4 - SN720; Calibrated: 1/19/2011 - Phantom: SAM 1560; Type: SAM; Serial: 1560 - Measurement SW: DASY4, V4.7 Build 80; Postprocessing SW: SEMCAD, V1.8 Build 186</p> <p>towards plantom - Low GPRS/Zoom Scan (7x7x7) (7x7x7)/Cube 0: Measurement grid: dx=5mm, dy=5mm, dz=5mm Reference Value = 24.8 V/m; Power Drift = -0.045 dB Peak SAR (extrapolated) = 1.26 W/kg SAR(1 g) = 0.931 mW/g; SAR(10 g) = 0.664 mW/g Maximum value of SAR (measured) = 0.984 mW/g</p> <div data-bbox="140 1220 1173 1848"> </div>		

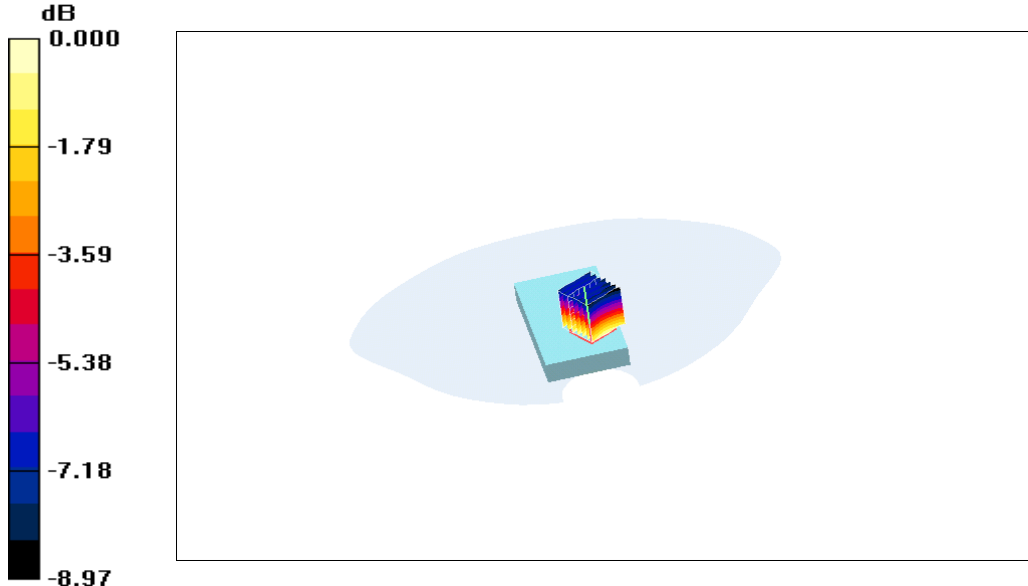
FLAT	Towards phantom	848.8MHz
<p>Communication System: GSM 850; Frequency: 848.8 MHz; Duty Cycle: 1:8.3 Medium parameters used (interpolated): $f = 848.8$ MHz; $\sigma = 1$ mho/m; $\epsilon_r = 54.6$; $\rho = 1000$ kg/m³ Phantom section: Flat Section</p> <p>DASY4 Configuration: - Probe: ES3DV3 - SN3128; ConvF(6.78, 7.02, 6.8); Calibrated: 6/22/2010 - Sensor-Surface: 4mm (Mechanical Surface Detection) - Electronics: DAE4 - SN720; Calibrated: 1/19/2011 - Phantom: SAM 1560; Type: SAM; Serial: 1560 - Measurement SW: DASY4, V4.7 Build 80; Postprocessing SW: SEMCAD, V1.8 Build 186</p> <p>Towards phantom - GPRS high-3/Zoom Scan (7x7x7) (7x7x7)/Cube 0: Measurement grid: dx=5mm, dy=5mm, dz=5mm Reference Value = 25.2 V/m; Power Drift = -0.029 dB Peak SAR (extrapolated) = 1.40 W/kg SAR(1 g) = 1.04 mW/g; SAR(10 g) = 0.740 mW/g Maximum value of SAR (measured) = 1.10 mW/g</p>		
 <p>0 dB = 1.10 mW/g</p>		

GSM (850MHz with EGPRS/Flat)

FLAT	Towards ground	836.4 MHz
<p>Communication System: GSM 850; Frequency: 836.4 MHz; Duty Cycle: 1:8.3 Medium parameters used (interpolated): $f = 836.4$ MHz; $\sigma = 0.99$ mho/m; $\epsilon_r = 53.7$; $\rho = 1000$ kg/m³ Phantom section: Flat Section</p> <p>DASY4 Configuration: - Probe: ES3DV3 - SN3128; ConvF(6.78, 7.02, 6.8); Calibrated: 6/22/2010 - Sensor-Surface: 4mm (Mechanical Surface Detection) - Electronics: DAE4 - SN720; Calibrated: 1/19/2011 - Phantom: SAM 1560; Type: SAM; Serial: 1560 - Measurement SW: DASY4, V4.7 Build 80; Postprocessing SW: SEMCAD, V1.8 Build 186</p> <p>towards ground-Middle EDGE/Zoom Scan (7x7x7) (7x7x7)/Cube 0: Measurement grid: dx=5mm, dy=5mm, dz=5mm Reference Value = 12.7 V/m; Power Drift = -0.203 dB Peak SAR (extrapolated) = 0.560 W/kg SAR(1 g) = 0.414 mW/g; SAR(10 g) = 0.294 mW/g Maximum value of SAR (measured) = 0.440 mW/g</p> <div data-bbox="140 1249 1173 1780"> </div> <p>0 dB = 0.440mW/g</p>		

FLAT	Towards ground	824.2 MHz
<p>Communication System: GSM 850; Frequency: 824.2 MHz; Duty Cycle: 1:8.3 Medium parameters used: $f = 825$ MHz; $\sigma = 0.968$ mho/m; $\epsilon_r = 53.1$; $\rho = 1000$ kg/m³ Phantom section: Flat Section</p> <p>DASY4 Configuration: - Probe: ES3DV3 - SN3128; ConvF(6.78, 7.02, 6.8); Calibrated: 6/22/2010 - Sensor-Surface: 4mm (Mechanical Surface Detection) - Electronics: DAE4 - SN720; Calibrated: 1/19/2011 - Phantom: SAM 1560; Type: SAM; Serial: 1560 - Measurement SW: DASY4, V4.7 Build 80; Postprocessing SW: SEMCAD, V1.8 Build 186</p> <p>towards ground-Low EDGE/Zoom Scan (7x7x7) (7x7x7)/Cube 0: Measurement grid: dx=5mm, dy=5mm, dz=5mm Reference Value = 11.4 V/m; Power Drift = -0.104 dB Peak SAR (extrapolated) = 0.564 W/kg SAR(1 g) = 0.423 mW/g; SAR(10 g) = 0.301 mW/g Maximum value of SAR (measured) = 0.452 mW/g</p> <div data-bbox="140 1176 1173 1814"> <p>dB 0.000 -1.82 -3.64 -5.45 -7.27 -9.09</p> </div> <p>0 dB = 0.452 mW/g</p>		

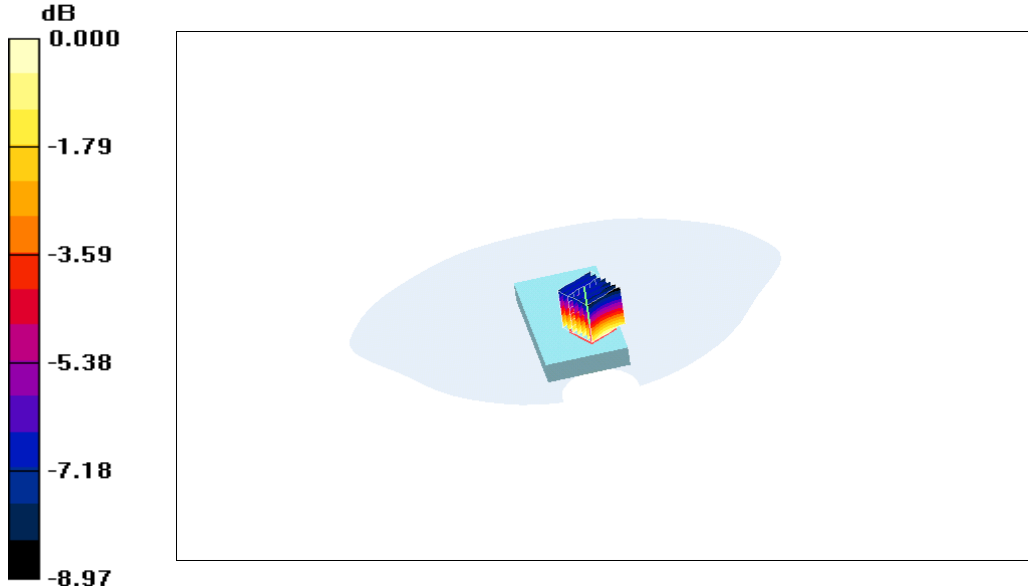
FLAT	Towards ground	848.8MHz
<p>Communication System: GSM 850; Frequency: 848.8 MHz;Duty Cycle: 1:8.3 Medium parameters used (interpolated): $f = 848.8 \text{ MHz}$; $\sigma = 1 \text{ mho/m}$; $\epsilon_r = 54.6$; $\rho = 1000 \text{ kg/m}^3$ Phantom section: Flat Section</p> <p>DASY4 Configuration: - Probe: ES3DV3 - SN3128; ConvF(6.78, 7.02, 6.8); Calibrated: 6/22/2010 - Sensor-Surface: 4mm (Mechanical Surface Detection) - Electronics: DAE4 - SN720; Calibrated: 1/19/2011 - Phantom: SAM 1560; Type: SAM; Serial: 1560 - Measurement SW: DASY4, V4.7 Build 80; Postprocessing SW: SEMCAD, V1.8 Build 186</p> <p>towards ground-High EDGE/Zoom Scan (7x7x7) (7x7x7)/Cube 0: Measurement grid: $dx=5\text{mm}$, $dy=5\text{mm}$, $dz=5\text{mm}$ Reference Value = 11.9 V/m; Power Drift = 0.052 dB Peak SAR (extrapolated) = 0.606 W/kg SAR(1 g) = 0.450 mW/g; SAR(10 g) = 0.319 mW/g Maximum value of SAR (measured) = 0.477 mW/g</p>		
 <p>0 dB = 0.477 mW/g</p>		

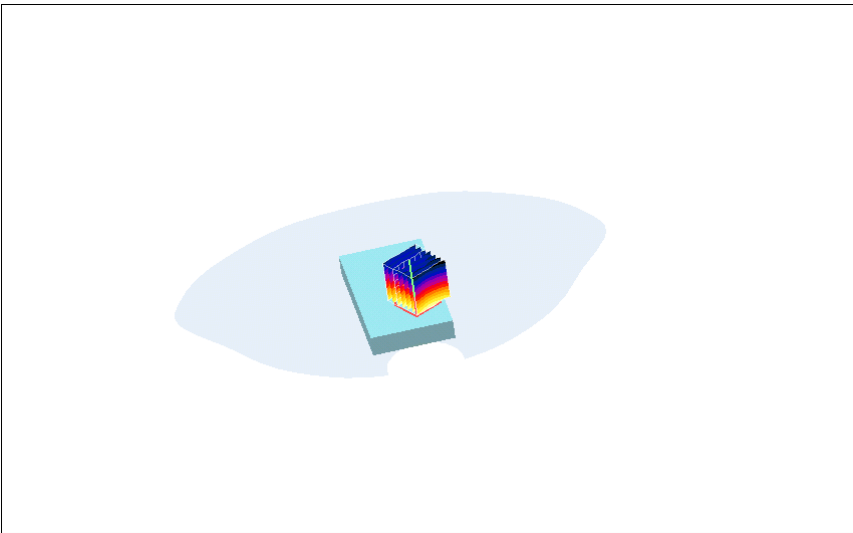
FLAT	Towards phantom	836.4 MHz
<p>Communication System: GSM 850; Frequency: 836.4 MHz; Duty Cycle: 1:8.3 Medium parameters used (interpolated): $f = 836.4$ MHz; $\sigma = 0.99$ mho/m; $\epsilon_r = 53.7$; $\rho = 1000$ kg/m³ Phantom section: Flat Section</p> <p>DASY4 Configuration: - Probe: ES3DV3 - SN3128; ConvF(6.78, 7.02, 6.8); Calibrated: 6/22/2010 - Sensor-Surface: 4mm (Mechanical Surface Detection) - Electronics: DAE4 - SN720; Calibrated: 1/19/2011 - Phantom: SAM 1560; Type: SAM; Serial: 1560 - Measurement SW: DASY4, V4.7 Build 80; Postprocessing SW: SEMCAD, V1.8 Build 186</p> <p>towards phantom-Middle EDGE/Zoom Scan (7x7x7) (7x7x7)/Cube 0: Measurement grid: dx=5mm, dy=5mm, dz=5mm Reference Value = 22.9 V/m; Power Drift = -0.020 dB Peak SAR (extrapolated) = 1.10 W/kg SAR(1 g) = 0.796 mW/g; SAR(10 g) = 0.560 mW/g Maximum value of SAR (measured) = 0.850 mW/g</p>		
<div style="display: flex; align-items: center;"> <div style="margin-right: 20px;"> <p>dB</p> <p>0.000</p> <p>-1.82</p> <p>-3.63</p> <p>-5.45</p> <p>-7.26</p> <p>-9.08</p> </div> <div style="flex-grow: 1;">  </div> </div> <p style="text-align: center;">0 dB = 0.850mW/g</p>		

FLAT	Towards phantom	824.2 MHz
<p>Communication System: GSM 850; Frequency: 824.2 MHz; Duty Cycle: 1:8.3 Medium parameters used: $f = 825$ MHz; $\sigma = 0.968$ mho/m; $\epsilon_r = 53.1$; $\rho = 1000$ kg/m³ Phantom section: Flat Section</p> <p>DASY4 Configuration: - Probe: ES3DV3 - SN3128; ConvF(6.78, 7.02, 6.8); Calibrated: 6/22/2010 - Sensor-Surface: 4mm (Mechanical Surface Detection) - Electronics: DAE4 - SN720; Calibrated: 1/19/2011 - Phantom: SAM 1560; Type: SAM; Serial: 1560 - Measurement SW: DASY4, V4.7 Build 80; Postprocessing SW: SEMCAD, V1.8 Build 186</p> <p>towards plantom -Low EDGE/Zoom Scan (7x7x7) (7x7x7)/Cube 0: Measurement grid: dx=5mm, dy=5mm, dz=5mm Reference Value = 22.0 V/m; Power Drift = -0.052 dB Peak SAR (extrapolated) = 1.01 W/kg SAR(1 g) = 0.746 mW/g; SAR(10 g) = 0.537 mW/g Maximum value of SAR (measured) = 0.786 mW/g</p> <div data-bbox="140 1220 1173 1848"> </div> <p>0 dB = 0.786mW/g</p>		

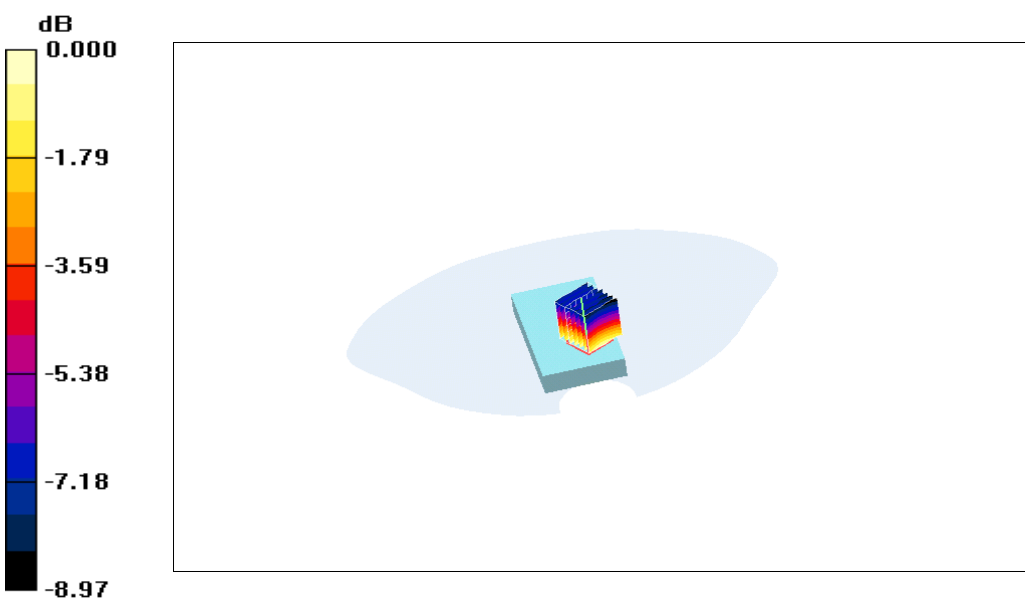
FLAT	Towards phantom	848.8MHz
<p>Communication System: GSM 850; Frequency: 848.8 MHz; Duty Cycle: 1:8.3 Medium parameters used (interpolated): $f = 848.8 \text{ MHz}$; $\sigma = 1 \text{ mho/m}$; $\epsilon_r = 54.6$; $\rho = 1000 \text{ kg/m}^3$ Phantom section: Flat Section</p> <p>DASY4 Configuration: - Probe: ES3DV3 - SN3128; ConvF(6.78, 7.02, 6.8); Calibrated: 6/22/2010 - Sensor-Surface: 4mm (Mechanical Surface Detection) - Electronics: DAE4 - SN720; Calibrated: 1/19/2011 - Phantom: SAM 1560; Type: SAM; Serial: 1560 - Measurement SW: DASY4, V4.7 Build 80; Postprocessing SW: SEMCAD, V1.8 Build 186</p> <p>towards plantom -High EDGE/Zoom Scan (7x7x7) (7x7x7)/Cube 0: Measurement grid: $dx=5\text{mm}$, $dy=5\text{mm}$, $dz=5\text{mm}$ Reference Value = 24.0 V/m; Power Drift = -0.082 dB Peak SAR (extrapolated) = 1.16 W/kg SAR(1 g) = 0.865 mW/g; SAR(10 g) = 0.618 mW/g Maximum value of SAR (measured) = 0.917 mW/g</p>		
 <p>0 dB = 0.917 mW/g</p>		

GSM (1900MHz/Head)

Right Side	Cheek	1850.2 MHz
<p>Communication System: PCS1900; Frequency: 1850.2 MHz; Duty Cycle: 1:8.3 Medium parameters used (interpolated): $f = 1850.2$ MHz; $\sigma = 1.41$ mho/m; $\epsilon_r = 39.2$; $\rho = 1000$ kg/m³ Phantom section: Right Section</p> <p>DASY4 Configuration: - Probe: ES3DV3 - SN3128; ConvF(4.95, 5.22, 5.06); Calibrated: 6/22/2010 - Sensor-Surface: 4mm (Mechanical Surface Detection) - Electronics: DAE4 - SN720; Calibrated: 1/19/2011 - Phantom: SAM 1559; Type: SAM; Serial: 1559 - Measurement SW: DASY4, V4.7 Build 80; Postprocessing SW: SEMCAD, V1.8 Build 186</p> <p>worst case touch low/Zoom Scan (7x7x7) (7x7x7)/Cube 0: Measurement grid: dx=5mm, dy=5mm, dz=5mm Reference Value = 13.0 V/m; Power Drift = -0.113 dB Peak SAR (extrapolated) = 1.40 W/kg SAR(1 g) = 0.918 mW/g; SAR(10 g) = 0.564 mW/g</p> <p>Maximum value of SAR (measured) = 0.991 mW/g</p> <div data-bbox="140 1310 949 1691"> </div> <p>0 dB = 0.991mW/g</p>		

Right Side	Cheek	1880.0 MHz
<p>Communication System: PCS1900; Frequency: 1880 MHz; Duty Cycle: 1:8.3 Medium parameters used: $f = 1880$ MHz; $\sigma = 1.44$ mho/m; $\epsilon_r = 39$; $\rho = 1000$ kg/m³ Phantom section: Right Section</p> <p>DASY4 Configuration: - Probe: ES3DV3 - SN3128; ConvF(4.95, 5.22, 5.06); Calibrated: 6/22/2010 - Sensor-Surface: 4mm (Mechanical Surface Detection) - Electronics: DAE4 - SN720; Calibrated: 1/19/2011 - Phantom: SAM 1559; Type: SAM; Serial: 1559 - Measurement SW: DASY4, V4.7 Build 80; Postprocessing SW: SEMCAD, V1.8 Build 186</p> <p>Touch position - Middle/Zoom Scan (7x7x7) (7x7x7)/Cube 0: Measurement grid: dx=5mm, dy=5mm, dz=5mm Reference Value = 12.1 V/m; Power Drift = -0.003 dB Peak SAR (extrapolated) = 1.34 W/kg SAR(1 g) = 0.877 mW/g; SAR(10 g) = 0.541 mW/g Maximum value of SAR (measured) = 0.948 mW/g</p> <div data-bbox="236 1182 1013 1792"> </div> <p>0 dB = 0.948mW/g</p>		

Right Side	Cheek	1909.8 MHz
<p>Communication System: PCS1900; Frequency: 1909.8 MHz; Duty Cycle: 1:8.3 Medium parameters used: $f = 1910$ MHz; $\sigma = 1.46$ mho/m; $\epsilon_r = 38.8$; $\rho = 1000$ kg/m³ Phantom section: Right Section</p> <p>DASY4 Configuration: - Probe: ES3DV3 - SN3128; ConvF(4.95, 5.22, 5.06); Calibrated: 6/22/2010 - Sensor-Surface: 4mm (Mechanical Surface Detection) - Electronics: DAE4 - SN720; Calibrated: 1/19/2011 - Phantom: SAM 1559; Type: SAM; Serial: 1559 - Measurement SW: DASY4, V4.7 Build 80; Postprocessing SW: SEMCAD, V1.8 Build 186</p> <p>worst case touch high/Zoom Scan (7x7x7) (7x7x7)/Cube 0: Measurement grid: dx=5mm, dy=5mm, dz=5mm Reference Value = 11.7 V/m; Power Drift = 0.014 dB Peak SAR (extrapolated) = 1.40 W/kg SAR(1 g) = 0.883 mW/g; SAR(10 g) = 0.541 mW/g Maximum value of SAR (measured) = 0.951 mW/g</p> <div data-bbox="316 1196 1088 1859"> </div> <p style="text-align: center;">0 dB = 0.951 mW/g</p>		

Right Side	tilt	1850.2 MHz
<p>Communication System: PCS1900; Frequency: 1850.2 MHz; Duty Cycle: 1:8.3 Medium parameters used (interpolated): $f = 1850.2$ MHz; $\sigma = 1.41$ mho/m; $\epsilon_r = 39.2$; $\rho = 1000$ kg/m³ Phantom section: Right Section</p> <p>DASY4 Configuration: - Probe: ES3DV3 - SN3128; ConvF(4.95, 5.22, 5.06); Calibrated: 6/22/2010 - Sensor-Surface: 4mm (Mechanical Surface Detection) - Electronics: DAE4 - SN720; Calibrated: 1/19/2011 - Phantom: SAM 1559; Type: SAM; Serial: 1559 - Measurement SW: DASY4, V4.7 Build 80; Postprocessing SW: SEMCAD, V1.8 Build 186</p> <p>tilt position low/Zoom Scan (7x7x7)/Cube 0: Measurement grid: dx=5mm, dy=5mm, dz=5mm Reference Value = 16.2 V/m; Power Drift = -0.011 dB Peak SAR (extrapolated) = 0.440 W/kg SAR(1 g) = 0.323 mW/g; SAR(10 g) = 0.210 mW/g Maximum value of SAR (measured) = 0.350 mW/g</p> <div data-bbox="140 1272 949 1646"> </div>		

Right Side	tilt	1880.0 MHz
<p>Communication System: PCS1900; Frequency: 1880 MHz; Duty Cycle: 1:8.3 Medium parameters used: $f = 1880$ MHz; $\sigma = 1.44$ mho/m; $\epsilon_r = 39$; $\rho = 1000$ kg/m³ Phantom section: Right Section</p> <p>DASY4 Configuration: - Probe: ES3DV3 - SN3128; ConvF(4.95, 5.22, 5.06); Calibrated: 6/22/2010 - Sensor-Surface: 4mm (Mechanical Surface Detection) - Electronics: DAE4 - SN720; Calibrated: 1/19/2011 - Phantom: SAM 1559; Type: SAM; Serial: 1559 - Measurement SW: DASY4, V4.7 Build 80; Postprocessing SW: SEMCAD, V1.8 Build 186</p> <p>Tilt position - Middle/Zoom Scan (7x7x7) (7x7x7)/Cube 0: Measurement grid: dx=5mm, dy=5mm, dz=5mm Reference Value = 15.7 V/m; Power Drift = 0.007 dB Peak SAR (extrapolated) = 0.432 W/kg SAR(1 g) = 0.306 mW/g; SAR(10 g) = 0.196 mW/g Maximum value of SAR (measured) = 0.330 mW/g</p> <div data-bbox="236 1182 1013 1792"> </div> <p style="text-align: center;">0 dB = 0.330mW/g</p>		

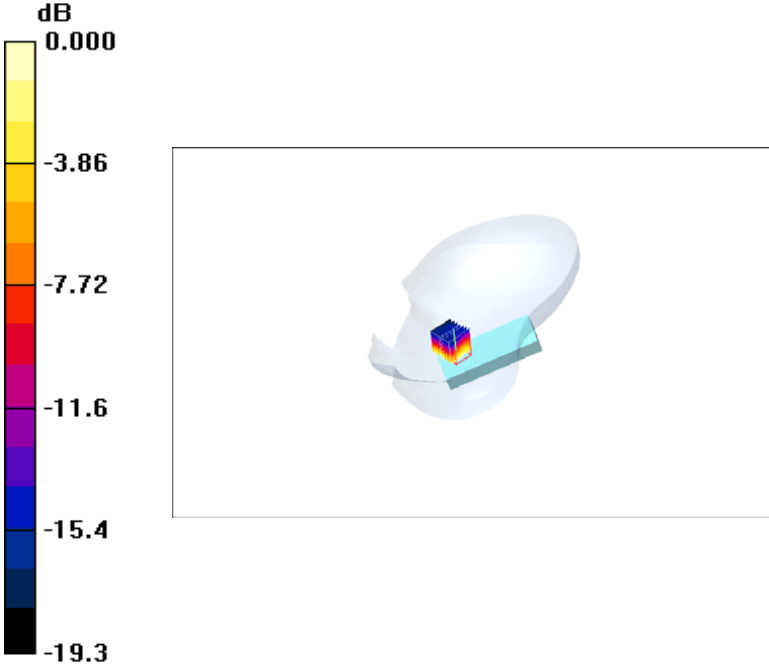
Right Side	tilt	1909.8 MHz
<p>Communication System: PCS1900; Frequency: 1909.8 MHz; Duty Cycle: 1:8.3 Medium parameters used: $f = 1910$ MHz; $\sigma = 1.46$ mho/m; $\epsilon_r = 38.8$; $\rho = 1000$ kg/m³ Phantom section: Right Section</p> <p>DASY4 Configuration: - Probe: ES3DV3 - SN3128; ConvF(4.95, 5.22, 5.06); Calibrated: 6/22/2010 - Sensor-Surface: 4mm (Mechanical Surface Detection) - Electronics: DAE4 - SN720; Calibrated: 1/19/2011 - Phantom: SAM 1559; Type: SAM; Serial: 1559 - Measurement SW: DASY4, V4.7 Build 80; Postprocessing SW: SEMCAD, V1.8 Build 186</p> <p>tilt position high/Zoom Scan (7x7x7)/Cube 0: Measurement grid: dx=5mm, dy=5mm, dz=5mm Reference Value = 15.6 V/m; Power Drift = -0.034 dB Peak SAR (extrapolated) = 0.454 W/kg SAR(1 g) = 0.311 mW/g; SAR(10 g) = 0.195 mW/g Maximum value of SAR (measured) = 0.336 mW/g</p>		
 <p style="text-align: center;">0 dB = 0.951 mW/g</p>		

Left Side	Cheek	1850.2 MHz
<p>Communication System: PCS1900; Frequency: 1850.2 MHz; Duty Cycle: 1:8.3 Medium parameters used (interpolated): $f = 1850.2 \text{ MHz}$; $\sigma = 1.41 \text{ mho/m}$; $\epsilon_r = 39.2$; $\rho = 1000 \text{ kg/m}^3$ Phantom section: Left Section</p> <p>DASY4 Configuration: - Probe: ES3DV3 - SN3128; ConvF(4.95, 5.22, 5.06); Calibrated: 6/22/2010 - Sensor-Surface: 4mm (Mechanical Surface Detection) - Electronics: DAE4 - SN720; Calibrated: 1/19/2011 - Phantom: SAM 1559; Type: SAM; Serial: 1559 - Measurement SW: DASY4, V4.7 Build 80; Postprocessing SW: SEMCAD, V1.8 Build 186</p> <p>worst case touch low/Zoom Scan (7x7x7) (7x7x7)/Cube 0: Measurement grid: $dx=5\text{mm}$, $dy=5\text{mm}$, $dz=5\text{mm}$ Reference Value = 12.1 V/m; Power Drift = -0.022 dB Peak SAR (extrapolated) = 1.74 W/kg SAR(1 g) = 1.03 mW/g; SAR(10 g) = 0.573 mW/g Maximum value of SAR (measured) = 1.16 mW/g</p> <div style="display: flex; align-items: center;"> <div style="margin-right: 20px;"> <p>dB</p> <p>0.000</p> <p>-3.24</p> <p>-6.48</p> <p>-9.72</p> <p>-13.0</p> <p>-16.2</p> </div> <div style="flex-grow: 1;">  </div> </div> <p style="text-align: center;">0 dB = 1.16 mW/g</p>		

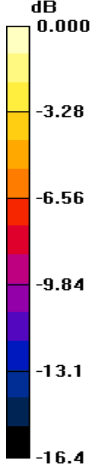
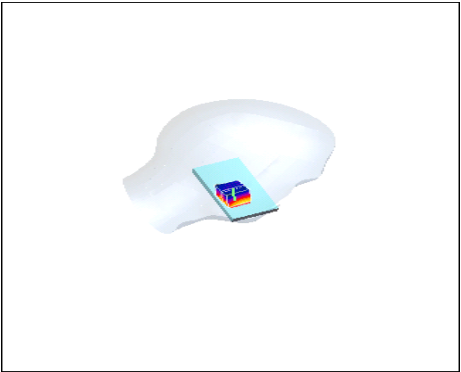
Left Side	Cheek	1880.0 MHz
<p>Communication System: PCS1900; Frequency: 1880 MHz; Duty Cycle: 1:8.3 Medium parameters used: $f = 1880$ MHz; $\sigma = 1.44$ mho/m; $\epsilon_r = 39$; $\rho = 1000$ kg/m³ Phantom section: Left Section</p> <p>DASY4 Configuration:</p> <ul style="list-style-type: none"> - Probe: ES3DV3 - SN3128; ConvF(4.95, 5.22, 5.06); Calibrated: 6/22/2010 - Sensor-Surface: 4mm (Mechanical Surface Detection) - Electronics: DAE4 - SN720; Calibrated: 1/19/2011 - Phantom: SAM 1559; Type: SAM; Serial: 1559 - Measurement SW: DASY4, V4.7 Build 80; Postprocessing SW: SEMCAD, V1.8 Build 186 <p>Touch position - Middle/Zoom Scan (7x7x7) (7x7x7)/Cube 0: Measurement grid: dx=5mm, dy=5mm, dz=5mm Reference Value = 11.4 V/m; Power Drift = -0.016 dB Peak SAR (extrapolated) = 1.65 W/kg SAR(1 g) = 0.961 mW/g; SAR(10 g) = 0.532 mW/g Maximum value of SAR (measured) = 1.08 mW/g</p> <div style="display: flex; align-items: center;"> <div style="margin-right: 20px;"> <p>dB</p>  </div> <div style="text-align: center;">  </div> </div> <p style="text-align: center; margin-top: 10px;">0 dB = 1.08 mW/g</p>		

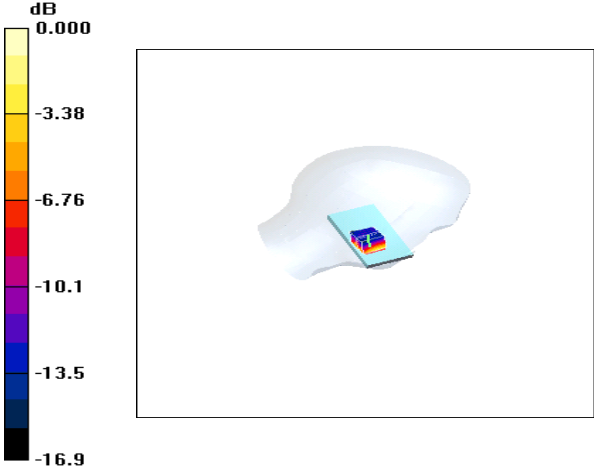
Left Side	Cheek	1909.8 MHz
<p>Communication System: PCS1900; Frequency: 1909.8 MHz; Duty Cycle: 1:8.3 Medium parameters used: $f = 1910$ MHz; $\sigma = 1.46$ mho/m; $\epsilon_r = 38.8$; $\rho = 1000$ kg/m³ Phantom section: Left Section</p> <p>DASY4 Configuration:</p> <ul style="list-style-type: none"> - Probe: ES3DV3 - SN3128; ConvF(4.95, 5.22, 5.06); Calibrated: 6/22/2010 - Sensor-Surface: 4mm (Mechanical Surface Detection) - Electronics: DAE4 - SN720; Calibrated: 1/19/2011 - Phantom: SAM 1559; Type: SAM; Serial: 1559 - Measurement SW: DASY4, V4.7 Build 80; Postprocessing SW: SEMCAD, V1.8 Build 186 <p>worst case touch high/Zoom Scan (7x7x7) (7x7x7)/Cube 0: Measurement grid: $dx=5mm, dy=5mm, dz=5mm$ Reference Value = 11.3 V/m; Power Drift = -0.043 dB Peak SAR (extrapolated) = 1.63 W/kg SAR(1 g) = 0.947 mW/g; SAR(10 g) = 0.520 mW/g Maximum value of SAR (measured) = 1.06 mW/g</p> <div style="display: flex; align-items: center;">  <div style="margin-left: 20px;"> <p>0 dB = 1.06mW/g</p> </div> </div>		

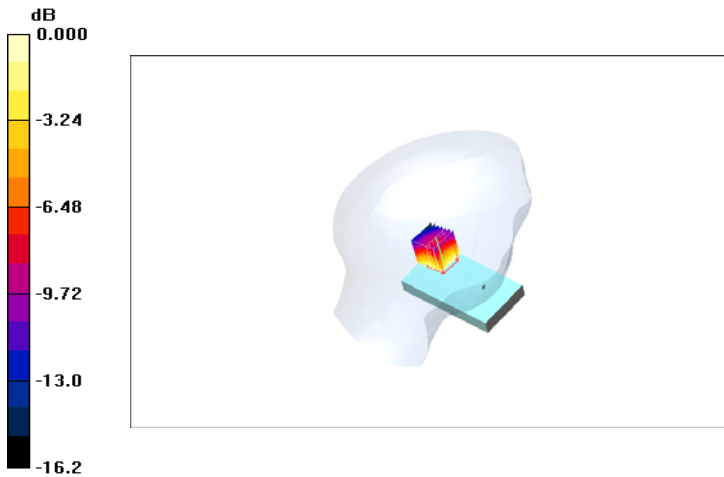
Left Side	tilt	1850.2 MHz
<p>Communication System: PCS1900; Frequency: 1850.2 MHz; Duty Cycle: 1:8.3 Medium parameters used (interpolated): $f = 1850.2$ MHz; $\sigma = 1.41$ mho/m; $\epsilon_r = 39.2$; $\rho = 1000$ kg/m³ Phantom section: Left Section</p> <p>DASY4 Configuration: - Probe: ES3DV3 - SN3128; ConvF(4.95, 5.22, 5.06); Calibrated: 6/22/2010 - Sensor-Surface: 4mm (Mechanical Surface Detection) - Electronics: DAE4 - SN720; Calibrated: 1/19/2011 - Phantom: SAM 1559; Type: SAM; Serial: 1559 - Measurement SW: DASY4, V4.7 Build 80; Postprocessing SW: SEMCAD, V1.8 Build 186</p> <p>tilt position low/Zoom Scan (7x7x7)/Cube 0: Measurement grid: dx=5mm, dy=5mm, dz=5mm Reference Value = 16.4 V/m; Power Drift = -0.007 dB Peak SAR (extrapolated) = 0.499 W/kg SAR(1 g) = 0.354 mW/g; SAR(10 g) = 0.228 mW/g</p> <p>Info: Interpolated medium parameters used for SAR evaluation. Maximum value of SAR (measured) = 0.379 mW/g</p>		
 <p>0 dB = 0.379 mW/g</p>		

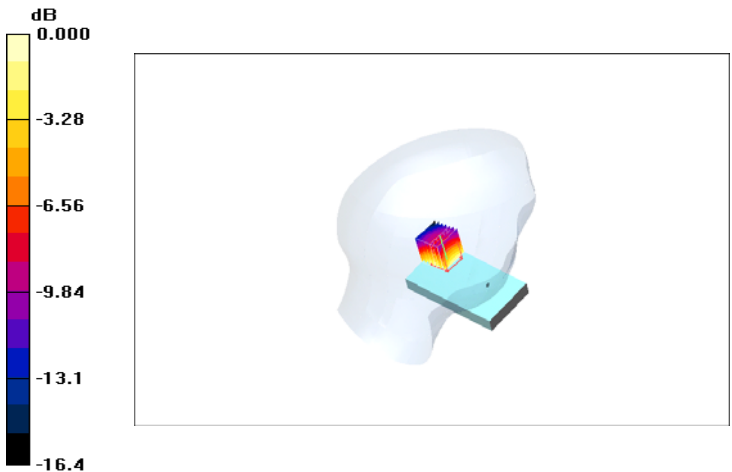
Left Side	tilt	1880.0 MHz
<p>Communication System: PCS1900; Frequency: 1880 MHz; Duty Cycle: 1:8.3 Medium parameters used: $f = 1880$ MHz; $\sigma = 1.44$ mho/m; $\epsilon_r = 39$; $\rho = 1000$ kg/m³ Phantom section: Left Section</p> <p>DASY4 Configuration: - Probe: ES3DV3 - SN3128; ConvF(4.95, 5.22, 5.06); Calibrated: 6/22/2010 - Sensor-Surface: 4mm (Mechanical Surface Detection) - Electronics: DAE4 - SN720; Calibrated: 1/19/2011 - Phantom: SAM 1559; Type: SAM; Serial: 1559 - Measurement SW: DASY4, V4.7 Build 80; Postprocessing SW: SEMCAD, V1.8 Build 186</p> <p>Tilt position - Middle/Zoom Scan (7x7x7) (7x7x7)/Cube 0: Measurement grid: $dx=5$mm, $dy=5$mm, $dz=5$mm Reference Value = 16.1 V/m; Power Drift = -0.025 dB Peak SAR (extrapolated) = 0.483 W/kg SAR(1 g) = 0.334 mW/g; SAR(10 g) = 0.213 mW/g</p> <p>Info: Interpolated medium parameters used for SAR evaluation. Maximum value of SAR (measured) = 0.360 mW/g</p> <div style="display: flex; align-items: center; justify-content: center;">  </div> <p style="text-align: center;">0 dB = 0.360 mW/g</p>		

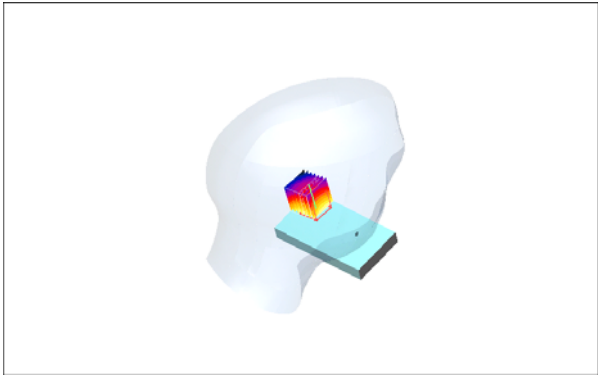
Left Side	tilt	1909.8 MHz
<p>Communication System: PCS1900; Frequency: 1909.8 MHz; Duty Cycle: 1:8.3 Medium parameters used: $f = 1910$ MHz; $\sigma = 1.46$ mho/m; $\epsilon_r = 38.8$; $\rho = 1000$ kg/m³ Phantom section: Left Section</p> <p>DASY4 Configuration:</p> <ul style="list-style-type: none"> - Probe: ES3DV3 - SN3128; ConvF(4.95, 5.22, 5.06); Calibrated: 6/22/2010 - Sensor-Surface: 4mm (Mechanical Surface Detection) - Electronics: DAE4 - SN720; Calibrated: 1/19/2011 - Phantom: SAM 1559; Type: SAM; Serial: 1559 - Measurement SW: DASY4, V4.7 Build 80; Postprocessing SW: SEMCAD, V1.8 Build 186 <p>tilt position high/Zoom Scan (7x7x7)/Cube 0: Measurement grid: dx=5mm, dy=5mm, dz=5mm Reference Value = 15.9 V/m; Power Drift = 0.034 dB Peak SAR (extrapolated) = 0.475 W/kg SAR(1 g) = 0.325 mW/g; SAR(10 g) = 0.205 mW/g Maximum value of SAR (measured) = 0.350 mW/g</p> <div style="display: flex; align-items: center;"> <div style="margin-right: 20px;"> <p>dB</p> <p>0.000</p> <p>-3.38</p> <p>-6.76</p> <p>-10.1</p> <p>-13.5</p> <p>-16.9</p> </div> <div style="flex-grow: 1;">  </div> </div> <p style="text-align: center;">0 dB = 0.350mW/g</p>		

GSM with headset (1900MHz/Flat)

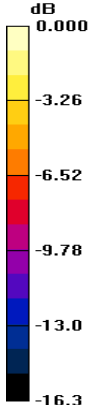
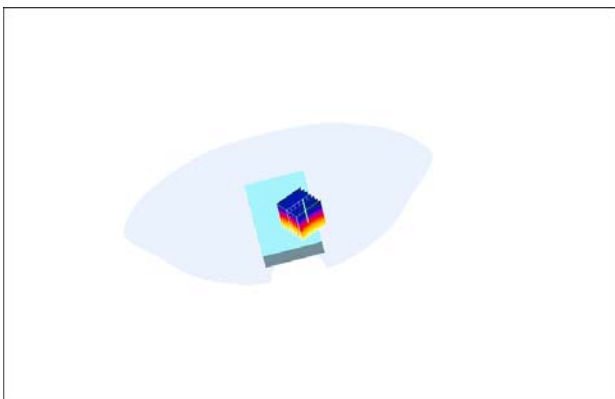
FLAT	Towards ground	1850.2 MHz
<p>Communication System: PCS1900; Frequency: 1850.2 MHz; Duty Cycle: 1:8.3 Medium parameters used (interpolated): $f = 1850.2$ MHz; $\sigma = 1.41$ mho/m; $\epsilon_r = 39.2$; $\rho = 1000$ kg/m³ Phantom section: Left Section</p> <p>DASY4 Configuration: - Probe: ES3DV3 - SN3128; ConvF(4.95, 5.22, 5.06); Calibrated: 6/22/2010 - Sensor-Surface: 4mm (Mechanical Surface Detection) - Electronics: DAE4 - SN720; Calibrated: 1/19/2011 - Phantom: SAM 1559; Type: SAM; Serial: 1559 - Measurement SW: DASY4, V4.7 Build 80; Postprocessing SW: SEMCAD, V1.8 Build 186</p> <p>Towards ground - low/Zoom Scan (7x7x7) (7x7x7)/Cube 0: Measurement grid: dx=5mm, dy=5mm, dz=5mm Reference Value = 7.05 V/m; Power Drift = 0.116 dB Peak SAR (extrapolated) = 0.913 W/kg SAR(1 g) = 0.559 mW/g; SAR(10 g) = 0.329 mW/g Maximum value of SAR (measured) = 0.608 mW/g</p>		
<div style="display: flex; align-items: center;"> <div style="margin-right: 20px;"> <p>dB</p>  </div> <div style="flex-grow: 1;">  </div> </div> <p style="text-align: center;">0 dB = 0.608 mW/g</p>		

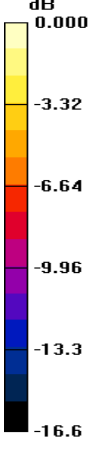
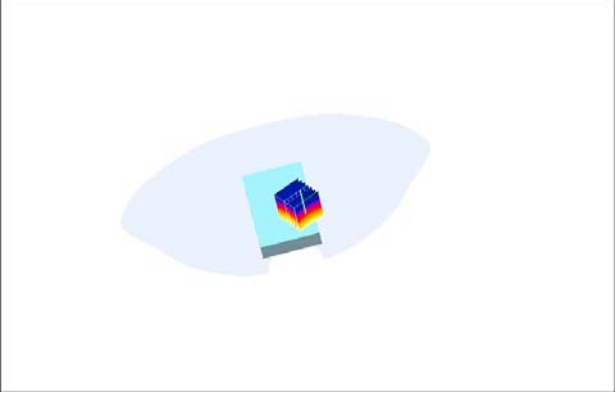
FLAT	Towards ground	1880 MHz
<p>Communication System: PCS1900; Frequency: 1880 MHz; Duty Cycle: 1:8.3 Medium parameters used: $f = 1880$ MHz; $\sigma = 1.57$ mho/m; $\epsilon_r = 53.5$; $\rho = 1000$ kg/m³ Phantom section: Flat Section</p> <p>DASY4 Configuration:</p> <ul style="list-style-type: none"> - Probe: ES3DV3 - SN3128; ConvF(4.53, 4.79, 4.63); Calibrated: 6/22/2010 - Sensor-Surface: 4mm (Mechanical Surface Detection) - Electronics: DAE4 - SN720; Calibrated: 1/19/2011 - Phantom: SAM 1559; Type: SAM; Serial: 1559 - Measurement SW: DASY4, V4.7 Build 80; Postprocessing SW: SEMCAD, V1.8 Build 186 <p>Towards ground - Middle/Zoom Scan (7x7x7) (7x7x7)/Cube 0: Measurement grid: dx=5mm, dy=5mm, dz=5mm Reference Value = 7.55 V/m; Power Drift = -0.008 dB Peak SAR (extrapolated) = 0.653 W/kg SAR(1 g) = 0.401 mW/g; SAR(10 g) = 0.239 mW/g Maximum value of SAR (measured) = 0.435 mW/g</p> <div style="display: flex; align-items: center;"> <div style="margin-right: 20px;"> <p>dB</p>  </div> <div style="flex-grow: 1;">  </div> </div> <p style="text-align: center;">0 dB = 0.435mW/g</p>		

FLAT	Towards ground	1909.8 MHz
<p>Communication System: PCS1900; Frequency: 1909.8 MHz; Duty Cycle: 1:8.3 Medium parameters used: $f = 1910$ MHz; $\sigma = 1.46$ mho/m; $\epsilon_r = 38.8$; $\rho = 1000$ kg/m³ Phantom section: Left Section</p>		
<p>DASY4 Configuration: - Probe: ES3DV3 - SN3128; ConvF(4.95, 5.22, 5.06); Calibrated: 6/22/2010 - Sensor-Surface: 4mm (Mechanical Surface Detection) - Electronics: DAE4 - SN720; Calibrated: 1/19/2011 - Phantom: SAM 1559; Type: SAM; Serial: 1559 - Measurement SW: DASY4, V4.7 Build 80; Postprocessing SW: SEMCAD, V1.8 Build 186</p>		
<p>Towards ground -high/Zoom Scan (7x7x7) (7x7x7)/Cube 0: Measurement grid: $dx=5$mm, $dy=5$mm, $dz=5$mm Reference Value = 8.85 V/m; Power Drift = 0.010 dB Peak SAR (extrapolated) = 1.04 W/kg SAR(1 g) = 0.625 mW/g; SAR(10 g) = 0.365 mW/g Maximum value of SAR (measured) = 0.675 mW/g</p>		
<div style="display: flex; align-items: center;"> <div style="margin-right: 20px;"> <p>dB</p> <p>0.000</p> <p>-3.32</p> <p>-6.64</p> <p>-9.96</p> <p>-13.3</p> <p>-16.6</p> </div> <div style="flex-grow: 1;">  </div> </div> <p style="text-align: center;">0 dB = 0.675mW/g</p>		

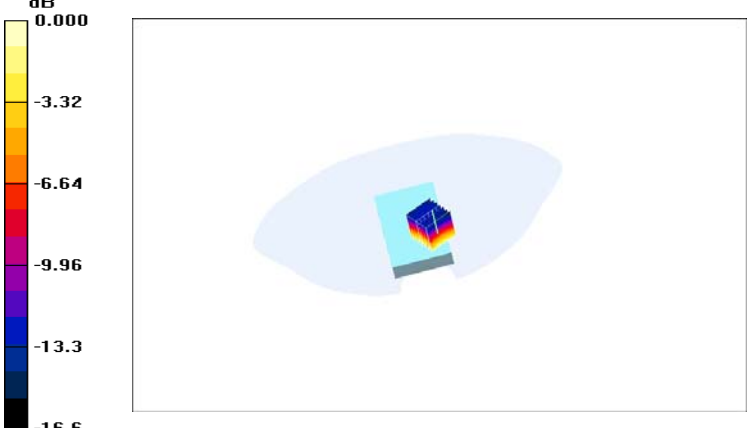
FLAT	Towards Phantom	1880 MHz
<p>Communication System: PCS1900; Frequency: 1880 MHz; Duty Cycle: 1:8.3 Medium parameters used: $f = 1880$ MHz; $\sigma = 1.57$ mho/m; $\epsilon_r = 53.5$; $\rho = 1000$ kg/m³ Phantom section: Flat Section</p> <p>DASY4 Configuration:</p> <ul style="list-style-type: none"> - Probe: ES3DV3 - SN3128; ConvF(4.53, 4.79, 4.63); Calibrated: 6/22/2010 - Sensor-Surface: 4mm (Mechanical Surface Detection) - Electronics: DAE4 - SN720; Calibrated: 1/19/2011 - Phantom: SAM 1559; Type: SAM; Serial: 1559 - Measurement SW: DASY4, V4.7 Build 80; Postprocessing SW: SEMCAD, V1.8 Build 186 <p>Towards phantom -middle/Zoom Scan (7x7x7) (7x7x7)/Cube 0: Measurement grid: dx=5mm, dy=5mm, dz=5mm Reference Value = 9.87 V/m; Power Drift = 0.050 dB Peak SAR (extrapolated) = 0.534 W/kg SAR(1 g) = 0.335 mW/g; SAR(10 g) = 0.201 mW/g Maximum value of SAR (measured) = 0.363 mW/g</p> <div style="display: flex; align-items: center;"> <div style="margin-right: 20px;"> <p>dB</p> <p>0.000</p> <p>-3.32</p> <p>-6.64</p> <p>-9.96</p> <p>-13.3</p> <p>-16.6</p> </div>  </div> <p style="text-align: center;">0 dB = 0.363mW/g</p>		

GSM (1900MHz with GPRS/Flat)

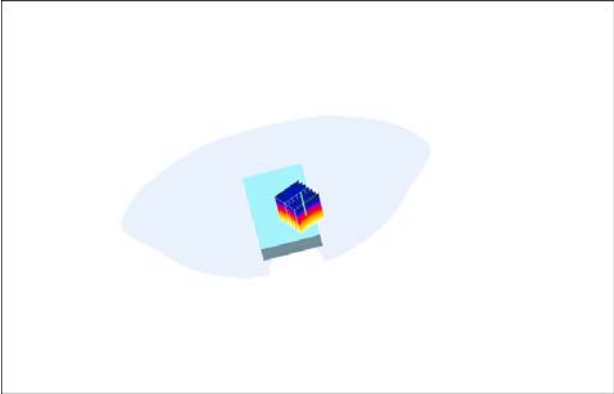
FLAT	Towards ground	1850.2 MHz
<p>Communication System: PCS1900; Frequency: 1850.2 MHz; Duty Cycle: 1:8.3 Medium parameters used (interpolated): $f = 1850.2$ MHz; $\sigma = 1.41$ mho/m; $\epsilon_r = 39.2$; $\rho = 1000$ kg/m³ Phantom section: Left Section</p> <p>DASY4 Configuration: - Probe: ES3DV3 - SN3128; ConvF(4.95, 5.22, 5.06); Calibrated: 6/22/2010 - Sensor-Surface: 4mm (Mechanical Surface Detection) - Electronics: DAE4 - SN720; Calibrated: 1/19/2011 - Phantom: SAM 1559; Type: SAM; Serial: 1559 - Measurement SW: DASY4, V4.7 Build 80; Postprocessing SW: SEMCAD, V1.8 Build 186</p> <p>towards ground - Low GPRS/Zoom Scan (7x7x7) (7x7x7)/Cube 0: Measurement grid: dx=5mm, dy=5mm, dz=5mm Reference Value = 11.0 V/m; Power Drift = -0.021 dB Peak SAR (extrapolated) = 1.24 W/kg SAR(1 g) = 0.700 mW/g; SAR(10 g) = 0.398 mW/g Maximum value of SAR (measured) = 0.760 mW/g</p>		
<div style="display: flex; align-items: center;"> <div style="margin-right: 20px;"> <p>dB</p> <p>0.000</p> <p>-3.26</p> <p>-6.52</p> <p>-9.78</p> <p>-13.0</p> <p>-16.3</p> </div> <div style="flex-grow: 1;">  </div> </div> <p style="text-align: center;">0 dB = 0.760 mW/g</p>		

FLAT	Towards ground	1880 MHz
<p>Communication System: PCS1900; Frequency: 1880 MHz; Duty Cycle: 1:8.3 Medium parameters used: $f = 1880$ MHz; $\sigma = 1.57$ mho/m; $\epsilon_r = 53.5$; $\rho = 1000$ kg/m³ Phantom section: Flat Section</p> <p>DASY4 Configuration:</p> <ul style="list-style-type: none"> - Probe: ES3DV3 - SN3128; ConvF(4.53, 4.79, 4.63); Calibrated: 6/22/2010 - Sensor-Surface: 4mm (Mechanical Surface Detection) - Electronics: DAE4 - SN720; Calibrated: 1/19/2011 - Phantom: SAM 1559; Type: SAM; Serial: 1559 - Measurement SW: DASY4, V4.7 Build 80; Postprocessing SW: SEMCAD, V1.8 Build 186 <p>towards ground - middle GPRS/Zoom Scan (7x7x7) (7x7x7)/Cube 0: Measurement grid: dx=5mm, dy=5mm, dz=5mm Reference Value = 10.2 V/m; Power Drift = 0.003 dB Peak SAR (extrapolated) = 1.23 W/kg SAR(1 g) = 0.721 mW/g; SAR(10 g) = 0.413 mW/g Maximum value of SAR (measured) = 0.782 mW/g</p> <div style="display: flex; align-items: center;"> <div style="margin-right: 20px;"> <p>dB</p> <p>0.000</p> <p>-3.32</p> <p>-6.64</p> <p>-9.96</p> <p>-13.3</p> <p>-16.6</p> </div> <div style="flex-grow: 1;">  </div> </div> <p style="text-align: center;">0 dB = 0.782mW/g</p>		

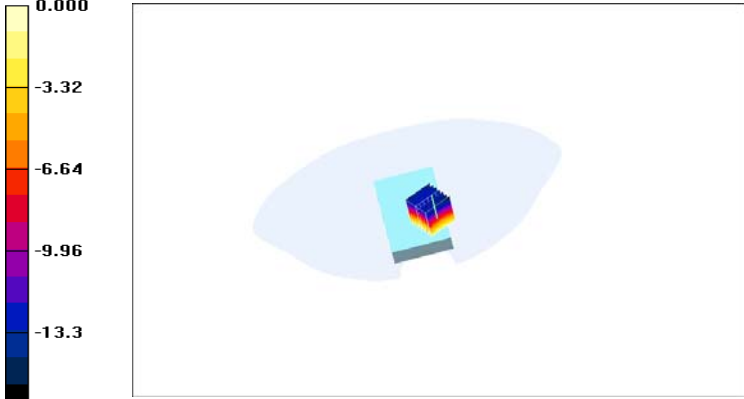
FLAT	Towards ground	1909.8 MHz
<p>Communication System: PCS1900; Frequency: 1909.8 MHz; Duty Cycle: 1:8.3 Medium parameters used: $f = 1910$ MHz; $\sigma = 1.46$ mho/m; $\epsilon_r = 38.8$; $\rho = 1000$ kg/m³ Phantom section: Left Section</p> <p>DASY4 Configuration:</p> <ul style="list-style-type: none"> - Probe: ES3DV3 - SN3128; ConvF(4.95, 5.22, 5.06); Calibrated: 6/22/2010 - Sensor-Surface: 4mm (Mechanical Surface Detection) - Electronics: DAE4 - SN720; Calibrated: 1/19/2011 - Phantom: SAM 1559; Type: SAM; Serial: 1559 - Measurement SW: DASY4, V4.7 Build 80; Postprocessing SW: SEMCAD, V1.8 Build 186 <p>towards ground- high GPRS/Zoom Scan (7x7x7) (7x7x7)/Cube 0: Measurement grid: dx=5mm, dy=5mm, dz=5mm Reference Value = 9.76 V/m; Power Drift = 0.059 dB Peak SAR (extrapolated) = 1.41 W/kg SAR(1 g) = 0.804 mW/g; SAR(10 g) = 0.459 mW/g Maximum value of SAR (measured) = 0.879 mW/g</p> <div style="display: flex; align-items: center;"> <div style="margin-right: 20px;"> <p>dB</p> <p>0.000</p> <p>-3.32</p> <p>-6.64</p> <p>-9.96</p> <p>-13.3</p> <p>-16.6</p> </div>  </div> <p style="text-align: center;">0 dB = 0.879mW/g</p>		

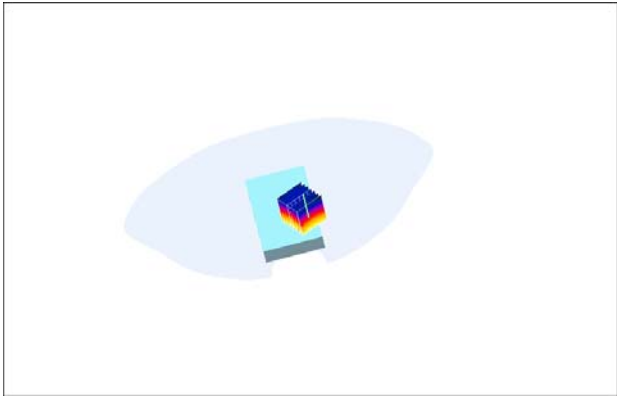
FLAT	Towards phantom	1880 MHz
<p>Communication System: PCS1900; Frequency: 1880 MHz; Duty Cycle: 1:8.3 Medium parameters used: $f = 1880 \text{ MHz}$; $\sigma = 1.57 \text{ mho/m}$; $\epsilon_r = 53.5$; $\rho = 1000 \text{ kg/m}^3$ Phantom section: Flat Section</p> <p>DASY4 Configuration:</p> <ul style="list-style-type: none"> - Probe: ES3DV3 - SN3128; ConvF(4.53, 4.79, 4.63); Calibrated: 6/22/2010 - Sensor-Surface: 4mm (Mechanical Surface Detection) - Electronics: DAE4 - SN720; Calibrated: 1/19/2011 - Phantom: SAM 1559; Type: SAM; Serial: 1559 - Measurement SW: DASY4, V4.7 Build 80; Postprocessing SW: SEMCAD, V1.8 Build 186 <p>towards phantom- middle GPRS/Zoom Scan (7x7x7) (7x7x7)/Cube 0:</p> <p>Measurement grid: $dx=5\text{mm}$, $dy=5\text{mm}$, $dz=5\text{mm}$ Reference Value = 9.94 V/m; Power Drift = -0.135 dB Peak SAR (extrapolated) = 0.531 W/kg SAR(1 g) = 0.326 mW/g; SAR(10 g) = 0.195 mW/g Maximum value of SAR (measured) = 0.352 mW/g</p> <div style="display: flex; align-items: center;"> <div style="margin-right: 20px;"> <p>dB</p> <p>0.000</p> <p>-3.32</p> <p>-6.64</p> <p>-9.96</p> <p>-13.3</p> <p>-16.6</p> </div>  </div> <p style="text-align: center;">0 dB = 0.352mW/g</p>		

GSM (1900MHz with EGPRS/Flat)

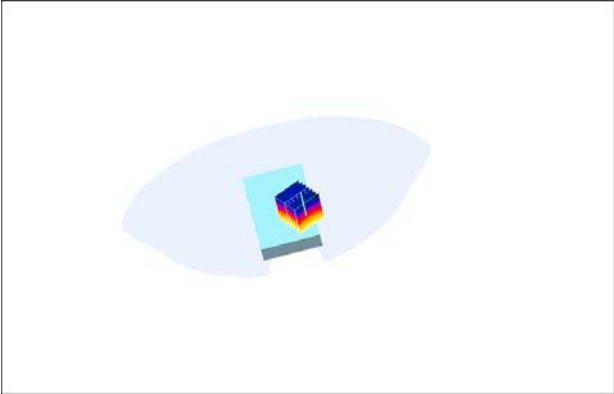
FLAT	Towards ground	1850.2 MHz
<p>Communication System: PCS1900; Frequency: 1850.2 MHz; Duty Cycle: 1:8.3 Medium parameters used (interpolated): $f = 1850.2$ MHz; $\sigma = 1.41$ mho/m; $\epsilon_r = 39.2$; $\rho = 1000$ kg/m³ Phantom section: Left Section</p> <p>DASY4 Configuration: - Probe: ES3DV3 - SN3128; ConvF(4.95, 5.22, 5.06); Calibrated: 6/22/2010 - Sensor-Surface: 4mm (Mechanical Surface Detection) - Electronics: DAE4 - SN720; Calibrated: 1/19/2011 - Phantom: SAM 1559; Type: SAM; Serial: 1559 - Measurement SW: DASY4, V4.7 Build 80; Postprocessing SW: SEMCAD, V1.8 Build 186</p> <p>towards ground-Low EDGE/Zoom Scan (7x7x7) (7x7x7)/Cube 0: Measurement grid: dx=5mm, dy=5mm, dz=5mm Reference Value = 6.90 V/m; Power Drift = 0.153 dB Peak SAR (extrapolated) = 0.509 W/kg SAR(1 g) = 0.288 mW/g; SAR(10 g) = 0.167 mW/g Maximum value of SAR (measured) = 0.311 mW/g</p>		
<div style="display: flex; align-items: center;"> <div style="margin-right: 20px;"> <p>dB</p> <p>0.000</p> <p>-3.26</p> <p>-6.52</p> <p>-9.78</p> <p>-13.0</p> <p>-16.3</p> </div> <div style="flex-grow: 1;">  </div> </div> <p style="text-align: center;">0 dB = 0.311 mW/g</p>		

FLAT	Towards ground	1880 MHz
<p>Communication System: PCS1900; Frequency: 1880 MHz; Duty Cycle: 1:8.3 Medium parameters used: $f = 1880$ MHz; $\sigma = 1.57$ mho/m; $\epsilon_r = 53.5$; $\rho = 1000$ kg/m³ Phantom section: Flat Section</p> <p>DASY4 Configuration:</p> <ul style="list-style-type: none"> - Probe: ES3DV3 - SN3128; ConvF(4.53, 4.79, 4.63); Calibrated: 6/22/2010 - Sensor-Surface: 4mm (Mechanical Surface Detection) - Electronics: DAE4 - SN720; Calibrated: 1/19/2011 - Phantom: SAM 1559; Type: SAM; Serial: 1559 - Measurement SW: DASY4, V4.7 Build 80; Postprocessing SW: SEMCAD, V1.8 Build 186 <p>towards ground-Middle EDGE/Zoom Scan (7x7x7) (7x7x7)/Cube 0: Measurement grid: dx=5mm, dy=5mm, dz=5mm Reference Value = 6.63 V/m; Power Drift = -0.179 dB Peak SAR (extrapolated) = 0.486 W/kg SAR(1 g) = 0.293 mW/g; SAR(10 g) = 0.171 mW/g Maximum value of SAR (measured) = 0.318 mW/g</p> <div style="display: flex; align-items: center;"> <div style="margin-right: 20px;"> <p>dB</p> <p>0.000 -3.32 -6.64 -9.96 -13.3 -16.6</p> </div> <div style="text-align: center;"> </div> </div> <p style="text-align: center;">0 dB = 0.318mW/g</p>		

FLAT	Towards ground	1909.8 MHz
<p>Communication System: PCS1900; Frequency: 1909.8 MHz; Duty Cycle: 1:8.3 Medium parameters used: $f = 1910$ MHz; $\sigma = 1.46$ mho/m; $\epsilon_r = 38.8$; $\rho = 1000$ kg/m³ Phantom section: Left Section</p>		
<p>DASY4 Configuration: - Probe: ES3DV3 - SN3128; ConvF(4.95, 5.22, 5.06); Calibrated: 6/22/2010 - Sensor-Surface: 4mm (Mechanical Surface Detection) - Electronics: DAE4 - SN720; Calibrated: 1/19/2011 - Phantom: SAM 1559; Type: SAM; Serial: 1559 - Measurement SW: DASY4, V4.7 Build 80; Postprocessing SW: SEMCAD, V1.8 Build 186</p>		
<p>towards ground-High EDGE/Zoom Scan (7x7x7) (7x7x7)/Cube 0: Measurement grid: dx=5mm, dy=5mm, dz=5mm Reference Value = 6.37 V/m; Power Drift = 0.032 dB Peak SAR (extrapolated) = 0.514 W/kg SAR(1 g) = 0.310 mW/g; SAR(10 g) = 0.182 mW/g Maximum value of SAR (measured) = 0.338 mW/g</p>		
<div style="display: flex; align-items: center;"> <div style="margin-right: 20px;"> <p>dB</p> <p>0.000</p> <p>-3.32</p> <p>-6.64</p> <p>-9.96</p> <p>-13.3</p> <p>-16.6</p> </div> <div style="flex-grow: 1;">  </div> </div> <p style="text-align: center;">0 dB = 0.338mW/g</p>		

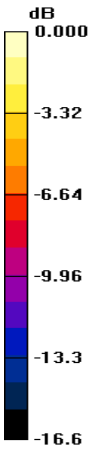
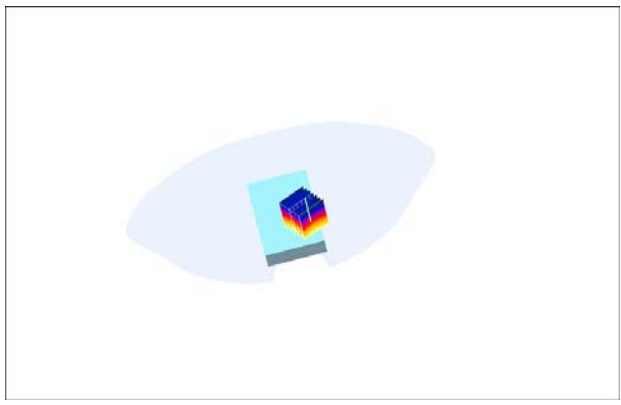
FLAT	Towards phantom	1880 MHz
<p>Communication System: PCS1900; Frequency: 1880 MHz; Duty Cycle: 1:8.3 Medium parameters used: $f = 1880$ MHz; $\sigma = 1.57$ mho/m; $\epsilon_r = 53.5$; $\rho = 1000$ kg/m³ Phantom section: Flat Section</p> <p>DASY4 Configuration:</p> <ul style="list-style-type: none"> - Probe: ES3DV3 - SN3128; ConvF(4.53, 4.79, 4.63); Calibrated: 6/22/2010 - Sensor-Surface: 4mm (Mechanical Surface Detection) - Electronics: DAE4 - SN720; Calibrated: 1/19/2011 - Phantom: SAM 1559; Type: SAM; Serial: 1559 - Measurement SW: DASY4, V4.7 Build 80; Postprocessing SW: SEMCAD, V1.8 Build 186 <p>towards phantom-Middle EDGE/Zoom Scan (7x7x7) (7x7x7)/Cube 0: Measurement grid: dx=5mm, dy=5mm, dz=5mm Reference Value = 9.50 V/m; Power Drift = 0.005 dB Peak SAR (extrapolated) = 0.490 W/kg SAR(1 g) = 0.305 mW/g; SAR(10 g) = 0.184 mW/g Maximum value of SAR (measured) = 0.330 mW/g</p> <div style="display: flex; align-items: center;"> <div style="margin-right: 20px;"> <p>dB</p>  </div> <div style="text-align: center;">  </div> </div> <p style="text-align: center;">0 dB = 0.330mW/g</p>		

WCDMA B5 (Head)

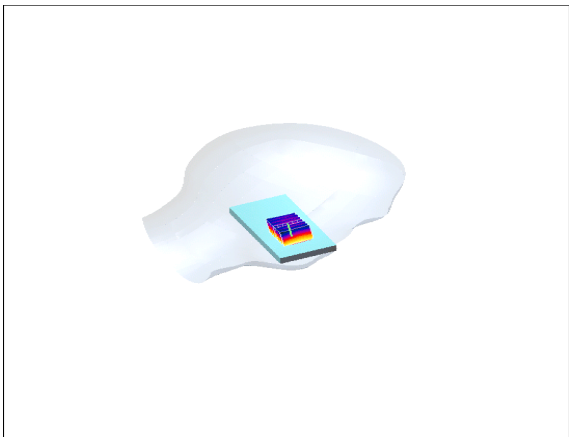
Left Side	Cheek	826.4 MHz
<p>Communication System: UMTS 835; Frequency: 826.4 MHz; Duty Cycle: 1:1 Medium parameters used (interpolated): $f = 826.4$ MHz; $\sigma = 0.888$ mho/m; $\epsilon_r = 41.9$; $\rho = 1000$ kg/m³ Phantom section: Left Section</p> <p>DASY4 Configuration: - Probe: ES3DV3 - SN3128; ConvF(7.88, 8.3, 8.05); Calibrated: 6/22/2010 - Sensor-Surface: 4mm (Mechanical Surface Detection) - Electronics: DAE4 - SN720; Calibrated: 1/19/2011 - Phantom: SAM 1560; Type: SAM; Serial: 1560 - Measurement SW: DASY4, V4.7 Build 80; Postprocessing SW: SEMCAD, V1.8 Build 186</p> <p>Touch position-low/Zoom Scan (7x7x7)/Cube 0: Measurement grid: dx=5mm, dy=5mm, dz=5mm Reference Value = 11.9 V/m; Power Drift = -0.086 dB Peak SAR (extrapolated) = 0.948 W/kg SAR(1 g) = 0.767 mW/g; SAR(10 g) = 0.569 mW/g Maximum value of SAR (measured) = 0.809 mW/g</p> <div style="display: flex; align-items: center;"> <div style="margin-right: 20px;"> <p>dB</p> <p>0.000</p> <p>-2.80</p> <p>-5.60</p> <p>-8.40</p> <p>-11.2</p> <p>-14.0</p> </div> <div style="flex-grow: 1;">  <p style="text-align: center;">0 dB = 0.809mW/g</p> </div> </div>		

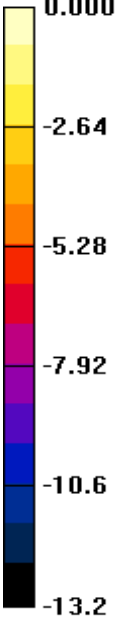
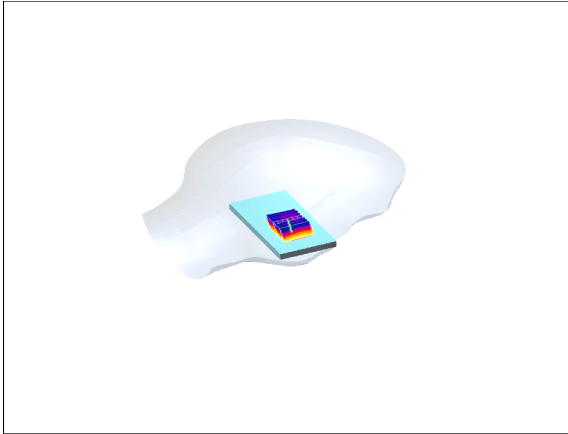
Left Side	Cheek	836.5 MHz
<p>Communication System: UMTS 835; Frequency: 836.5 MHz; Duty Cycle: 1:1 Medium parameters used (interpolated): $f = 836.5$ MHz; $\sigma = 0.897$ mho/m; $\epsilon_r = 41.6$; $\rho = 1000$ kg/m³ Phantom section: Left Section</p> <p>DASY4 Configuration: - Probe: ES3DV3 - SN3128; ConvF(7.88, 8.3, 8.05); Calibrated: 6/22/2010 - Sensor-Surface: 4mm (Mechanical Surface Detection) - Electronics: DAE4 - SN720; Calibrated: 1/19/2011 - Phantom: SAM 1560; Type: SAM; Serial: 1560 - Measurement SW: DASY4, V4.7 Build 80; Postprocessing SW: SEMCAD, V1.8 Build 186</p> <p>Touch position - Middle/Zoom Scan (7x7x7) (7x7x7)/Cube 0: Measurement grid: dx=5mm, dy=5mm, dz=5mm Reference Value = 13.3 V/m; Power Drift = -0.138 dB Peak SAR (extrapolated) = 0.891 W/kg SAR(1 g) = 0.735 mW/g; SAR(10 g) = 0.551 mW/g Maximum value of SAR (measured) = 0.775 mW/g</p>		
<div style="display: flex; align-items: center;"> <div style="margin-right: 20px;"> <p>dB</p> <p>0.000</p>  <p>-2.64</p> <p>-5.28</p> <p>-7.92</p> <p>-10.6</p> <p>-13.2</p> </div> <div style="text-align: center;">  </div> </div> <p style="text-align: center; margin-top: 10px;">0 dB = 0.775mW/g</p>		

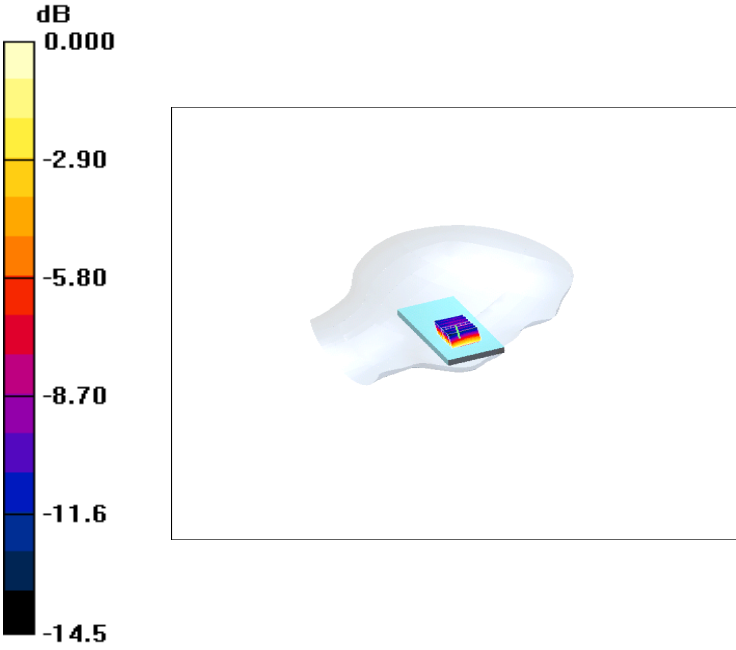
Left Side	Cheek	846.6 MHz
<p>Communication System: UMTS 835; Frequency: 846.6 MHz; Duty Cycle: 1:1 Medium parameters used (interpolated): $f = 846.6$ MHz; $\sigma = 0.905$ mho/m; $\epsilon_r = 41.7$; $\rho = 1000$ kg/m³ Phantom section: Left Section</p> <p>DASY4 Configuration: - Probe: ES3DV3 - SN3128; ConvF(7.88, 8.3, 8.05); Calibrated: 6/22/2010 - Sensor-Surface: 4mm (Mechanical Surface Detection) - Electronics: DAE4 - SN720; Calibrated: 1/19/2011 - Phantom: SAM 1560; Type: SAM; Serial: 1560 - Measurement SW: DASY4, V4.7 Build 80; Postprocessing SW: SEMCAD, V1.8 Build 186</p> <p>Touch position- high/Zoom Scan (7x7x7)/Cube 0: Measurement grid: dx=5mm, dy=5mm, dz=5mm Reference Value = 7.89 V/m; Power Drift = -0.199 dB Peak SAR (extrapolated) = 1.01 W/kg SAR(1 g) = 0.801 mW/g; SAR(10 g) = 0.592 mW/g Maximum value of SAR (measured) = 0.846 mW/g</p>		
 <p style="text-align: center;">0 dB = 0.846mW/g</p>		

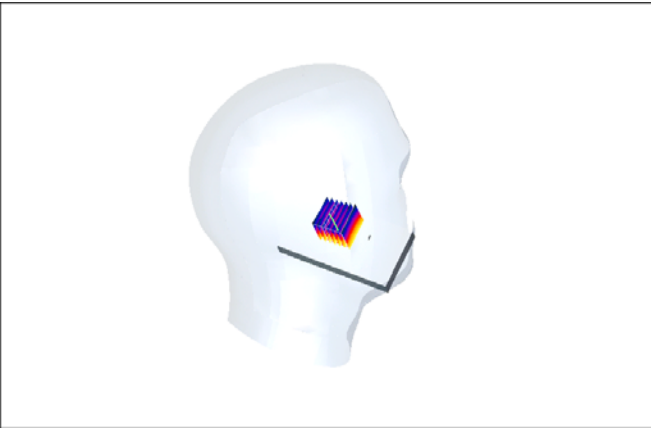
Left Side	Tilt	826.4 MHz
<p>Communication System: UMTS 835; Frequency: 826.4 MHz; Duty Cycle: 1:1 Medium parameters used (interpolated): $f = 826.4$ MHz; $\sigma = 0.888$ mho/m; $\epsilon_r = 41.9$; $\rho = 1000$ kg/m³ Phantom section: Left Section</p> <p>DASY4 Configuration: - Probe: ES3DV3 - SN3128; ConvF(7.88, 8.3, 8.05); Calibrated: 6/22/2010 - Sensor-Surface: 4mm (Mechanical Surface Detection) - Electronics: DAE4 - SN720; Calibrated: 1/19/2011 - Phantom: SAM 1560; Type: SAM; Serial: 1560 - Measurement SW: DASY4, V4.7 Build 80; Postprocessing SW: SEMCAD, V1.8 Build 186</p> <p>Tilt position -low/Zoom Scan (7x7x7)/Cube 0: Measurement grid: dx=5mm, dy=5mm, dz=5mm Reference Value = 15.8 V/m; Power Drift = -0.083 dB Peak SAR (extrapolated) = 0.420 W/kg SAR(1 g) = 0.350 mW/g; SAR(10 g) = 0.268 mW/g Maximum value of SAR (measured) = 0.370 mW/g</p>		
<div style="display: flex; align-items: center;"> <div style="margin-right: 20px;"> <p>dB</p> <p>0.000</p> <p>-1.83</p> <p>-3.66</p> <p>-5.48</p> <p>-7.31</p> <p>-9.14</p> </div> <div style="flex-grow: 1;">  </div> </div> <p style="text-align: center;">0 dB = 0.370mW/g</p>		

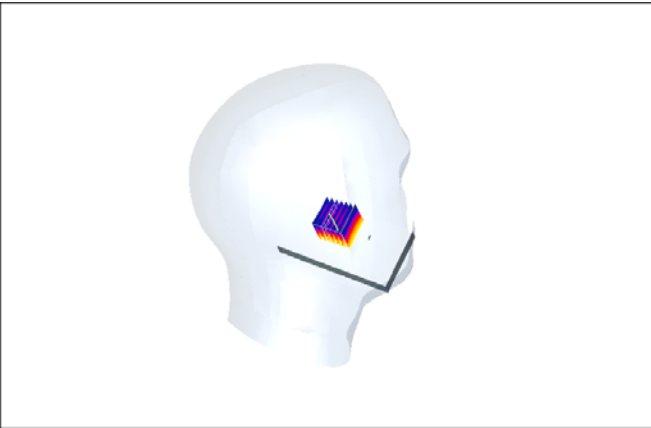
Left Side	Tilt	836.5 MHz
<p>Communication System: UMTS 835; Frequency: 836.5 MHz; Duty Cycle: 1:1 Medium parameters used (interpolated): $f = 836.5$ MHz; $\sigma = 0.897$ mho/m; $\epsilon_r = 41.6$; $\rho = 1000$ kg/m³ Phantom section: Left Section</p> <p>DASY4 Configuration: - Probe: ES3DV3 - SN3128; ConvF(7.88, 8.3, 8.05); Calibrated: 6/22/2010 - Sensor-Surface: 4mm (Mechanical Surface Detection) - Electronics: DAE4 - SN720; Calibrated: 1/19/2011 - Phantom: SAM 1560; Type: SAM; Serial: 1560 - Measurement SW: DASY4, V4.7 Build 80; Postprocessing SW: SEMCAD, V1.8 Build 186</p> <p>Tilt position-middle/Zoom Scan (7x7x7)/Cube 0: Measurement grid: dx=5mm, dy=5mm, dz=5mm Reference Value = 18.2 V/m; Power Drift = -0.061 dB Peak SAR (extrapolated) = 0.544 W/kg SAR(1 g) = 0.455 mW/g; SAR(10 g) = 0.347 mW/g Maximum value of SAR (measured) = 0.479 mW/g</p>		
<div style="display: flex; align-items: center;"> <div style="margin-right: 20px;"> <p>dB</p> <p>0.000</p> <p>-1.83</p> <p>-3.66</p> <p>-5.48</p> <p>-7.31</p> <p>-9.14</p> </div> <div style="flex-grow: 1;">  </div> </div> <p style="text-align: center;">0 dB = 0.479mW/g</p>		

Left Side	Tilt	846.6MHz
<p>Communication System: UMTS 835; Frequency: 846.6 MHz; Duty Cycle: 1:1 Medium parameters used (interpolated): $f = 846.6$ MHz; $\sigma = 0.905$ mho/m; $\epsilon_r = 41.7$; $\rho = 1000$ kg/m³ Phantom section: Left Section</p> <p>DASY4 Configuration: - Probe: ES3DV3 - SN3128; ConvF(7.88, 8.3, 8.05); Calibrated: 6/22/2010 - Sensor-Surface: 4mm (Mechanical Surface Detection) - Electronics: DAE4 - SN720; Calibrated: 1/19/2011 - Phantom: SAM 1560; Type: SAM; Serial: 1560 - Measurement SW: DASY4, V4.7 Build 80; Postprocessing SW: SEMCAD, V1.8 Build 186</p> <p>Tilt position-high/Zoom Scan (7x7x7)/Cube 0: Measurement grid: dx=5mm, dy=5mm, dz=5mm Reference Value = 17.6 V/m; Power Drift = -0.162 dB Peak SAR (extrapolated) = 0.531 W/kg SAR(1 g) = 0.437 mW/g; SAR(10 g) = 0.331 mW/g Maximum value of SAR (measured) = 0.464 mW/g</p> <div data-bbox="379 1265 1209 1848"> </div> <p style="text-align: center;">0 dB = 0.464mW/g</p>		

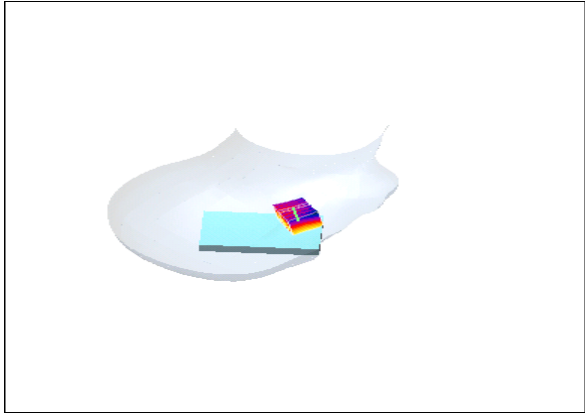
Right Side	Cheek	826.4 MHz
<p>Communication System: UMTS 835; Frequency: 826.4 MHz; Duty Cycle: 1:1 Medium parameters used (interpolated): $f = 826.4$ MHz; $\sigma = 0.888$ mho/m; $\epsilon_r = 41.9$; $\rho = 1000$ kg/m³ Phantom section: Left Section</p> <p>DASY4 Configuration: - Probe: ES3DV3 - SN3128; ConvF(7.88, 8.3, 8.05); Calibrated: 6/22/2010 - Sensor-Surface: 4mm (Mechanical Surface Detection) - Electronics: DAE4 - SN720; Calibrated: 1/19/2011 - Phantom: SAM 1560; Type: SAM; Serial: 1560 - Measurement SW: DASY4, V4.7 Build 80; Postprocessing SW: SEMCAD, V1.8 Build 186</p> <p>Touch position/Zoom Scan (7x7x7)/Cube 0: Measurement grid: dx=5mm, dy=5mm, dz=5mm Reference Value = 8.10 V/m; Power Drift = -0.109 dB Peak SAR (extrapolated) = 0.768 W/kg SAR(1 g) = 0.631 mW/g; SAR(10 g) = 0.475 mW/g Maximum value of SAR (measured) = 0.672 mW/g</p> <div style="display: flex; align-items: center;"> <div style="margin-right: 20px;"> <p>dB</p> <p>0.000</p> <p>-2.16</p> <p>-4.32</p> <p>-6.48</p> <p>-8.64</p> <p>-10.8</p> </div> <div style="flex-grow: 1;">  </div> </div> <p style="text-align: center;">0 dB = 0.672mW/g</p>		

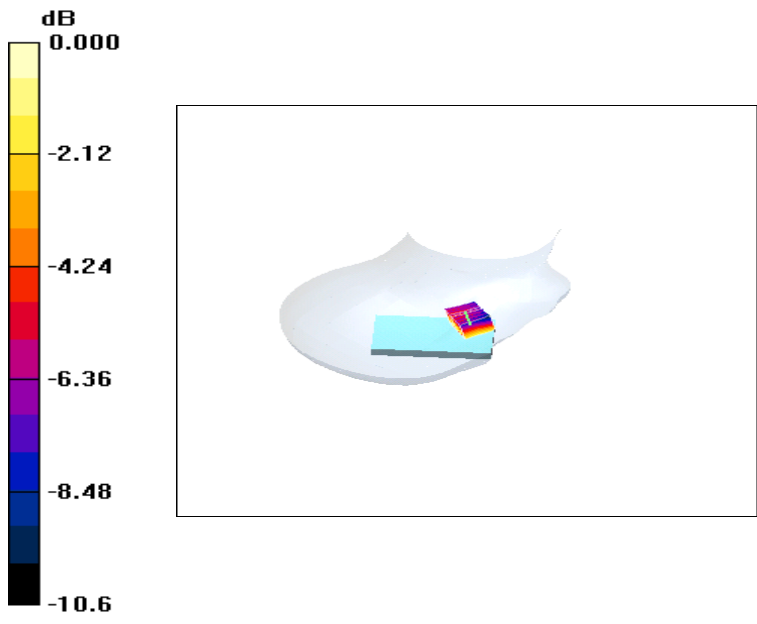
Right Side	Cheek	836.5 MHz
<p>Communication System: UMTS 835; Frequency: 836.5 MHz; Duty Cycle: 1:1 Medium parameters used (interpolated): $f = 836.5 \text{ MHz}$; $\sigma = 0.897 \text{ mho/m}$; $\epsilon_r = 41.6$; $\rho = 1000 \text{ kg/m}^3$ Phantom section: Left Section</p> <p>DASY4 Configuration: - Probe: ES3DV3 - SN3128; ConvF(7.88, 8.3, 8.05); Calibrated: 6/22/2010 - Sensor-Surface: 4mm (Mechanical Surface Detection) - Electronics: DAE4 - SN720; Calibrated: 1/19/2011 - Phantom: SAM 1560; Type: SAM; Serial: 1560 - Measurement SW: DASY4, V4.7 Build 80; Postprocessing SW: SEMCAD, V1.8 Build 186</p> <p>Touch position - Middle/Zoom Scan (7x7x7) (7x7x7)/Cube 0: Measurement grid: $dx=5\text{mm}$, $dy=5\text{mm}$, $dz=5\text{mm}$ Reference Value = 8.75 V/m; Power Drift = -0.073 dB Peak SAR (extrapolated) = 0.867 W/kg SAR(1 g) = 0.729 mW/g; SAR(10 g) = 0.559 mW/g Maximum value of SAR (measured) = 0.769 mW/g</p>		
 <p style="text-align: center;">0 dB = 0.769mW/g</p>		

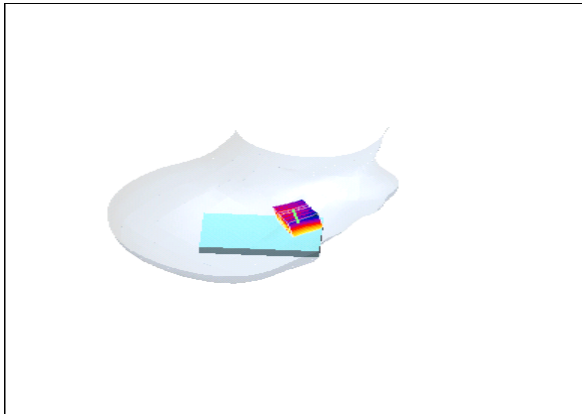
Right Side	Cheek	846.6 MHz
<p>Communication System: UMTS 835; Frequency: 846.6 MHz; Duty Cycle: 1:1 Medium parameters used (interpolated): $f = 846.6 \text{ MHz}$; $\sigma = 0.905 \text{ mho/m}$; $\epsilon_r = 41.7$; $\rho = 1000 \text{ kg/m}^3$ Phantom section: Left Section</p> <p>DASY4 Configuration: - Probe: ES3DV3 - SN3128; ConvF(7.88, 8.3, 8.05); Calibrated: 6/22/2010 - Sensor-Surface: 4mm (Mechanical Surface Detection) - Electronics: DAE4 - SN720; Calibrated: 1/19/2011 - Phantom: SAM 1560; Type: SAM; Serial: 1560 - Measurement SW: DASY4, V4.7 Build 80; Postprocessing SW: SEMCAD, V1.8 Build 186</p> <p>Touch high/Zoom Scan (7x7x7)/Cube 0: Measurement grid: dx=5mm, dy=5mm, dz=5mm Reference Value = 8.84 V/m; Power Drift = -0.011 dB Peak SAR (extrapolated) = 1.00 W/kg SAR(1 g) = 0.813 mW/g; SAR(10 g) = 0.610 mW/g Maximum value of SAR (measured) = 0.860 mW/g</p> <div style="display: flex; align-items: center;"> <div style="margin-right: 20px;"> <p>dB</p> <p>0.000</p> <p>-2.40</p> <p>-4.80</p> <p>-7.20</p> <p>-9.60</p> <p>-12.0</p> </div> <div style="flex-grow: 1;">  </div> </div> <p style="text-align: center;">0 dB = 0.860mW/g</p>		

Right Side	Tilt	826.4 MHz
<p>Communication System: UMTS 835; Frequency: 826.4 MHz; Duty Cycle: 1:1 Medium parameters used (interpolated): $f = 826.4$ MHz; $\sigma = 0.888$ mho/m; $\epsilon_r = 41.9$; $\rho = 1000$ kg/m³ Phantom section: Left Section</p> <p>DASY4 Configuration: - Probe: ES3DV3 - SN3128; ConvF(7.88, 8.3, 8.05); Calibrated: 6/22/2010 - Sensor-Surface: 4mm (Mechanical Surface Detection) - Electronics: DAE4 - SN720; Calibrated: 1/19/2011 - Phantom: SAM 1560; Type: SAM; Serial: 1560 - Measurement SW: DASY4, V4.7 Build 80; Postprocessing SW: SEMCAD, V1.8 Build 186</p> <p>Tilt position -low/Zoom Scan (7x7x7)/Cube 0: Measurement grid: dx=5mm, dy=5mm, dz=5mm Reference Value = 15.4 V/m; Power Drift = 0.003 dB Peak SAR (extrapolated) = 0.482 W/kg SAR(1 g) = 0.399 mW/g; SAR(10 g) = 0.306 mW/g Maximum value of SAR (measured) = 0.419 mW/g</p> <div data-bbox="411 1205 1177 1825"> </div>		

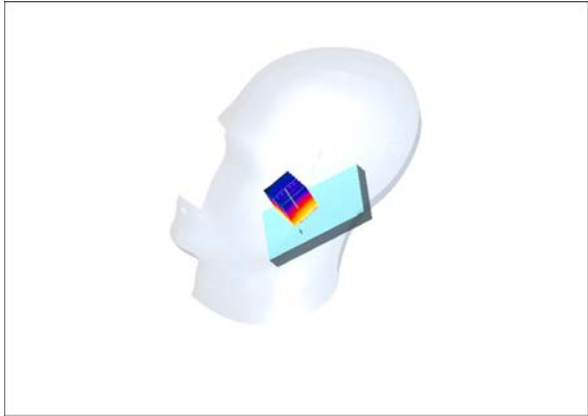
Right Side	Tilt	836.5 MHz
<p>Communication System: UMTS 835; Frequency: 836.5 MHz; Duty Cycle: 1:1 Medium parameters used (interpolated): $f = 836.5$ MHz; $\sigma = 0.897$ mho/m; $\epsilon_r = 41.6$; $\rho = 1000$ kg/m³ Phantom section: Left Section</p> <p>DASY4 Configuration: - Probe: ES3DV3 - SN3128; ConvF(7.88, 8.3, 8.05); Calibrated: 6/22/2010 - Sensor-Surface: 4mm (Mechanical Surface Detection) - Electronics: DAE4 - SN720; Calibrated: 1/19/2011 - Phantom: SAM 1560; Type: SAM; Serial: 1560 - Measurement SW: DASY4, V4.7 Build 80; Postprocessing SW: SEMCAD, V1.8 Build 186</p> <p>Tilt position-middle/Zoom Scan (7x7x7)/Cube 0: Measurement grid: dx=5mm, dy=5mm, dz=5mm Reference Value = 12.9 V/m; Power Drift = -0.047 dB Peak SAR (extrapolated) = 0.434 W/kg SAR(1 g) = 0.363 mW/g; SAR(10 g) = 0.279 mW/g Maximum value of SAR (measured) = 0.386 mW/g</p> <div style="display: flex; align-items: center;"> <div style="margin-right: 20px;"> <p>dB</p> <p>0.000</p> <p>-1.80</p> <p>-3.60</p> <p>-5.39</p> <p>-7.19</p> <p>-8.99</p> </div> <div style="text-align: center;">  </div> </div> <p style="text-align: center;">0 dB = 0.386mW/g</p>		

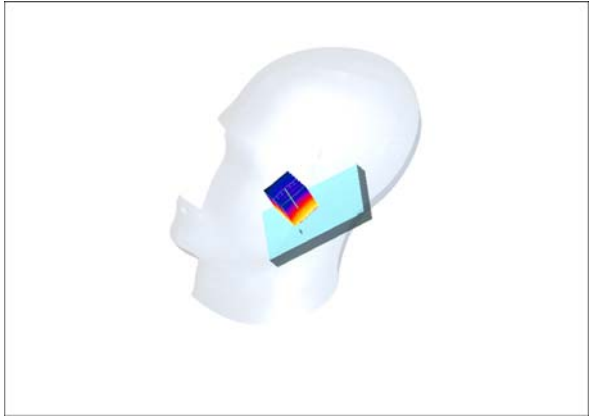
Right Side	Tilt	846.6MHz
<p>Communication System: UMTS 835; Frequency: 846.6 MHz; Duty Cycle: 1:1 Medium parameters used (interpolated): $f = 846.6$ MHz; $\sigma = 0.905$ mho/m; $\epsilon_r = 41.7$; $\rho = 1000$ kg/m³ Phantom section: Left Section</p> <p>DASY4 Configuration: - Probe: ES3DV3 - SN3128; ConvF(7.88, 8.3, 8.05); Calibrated: 6/22/2010 - Sensor-Surface: 4mm (Mechanical Surface Detection) - Electronics: DAE4 - SN720; Calibrated: 1/19/2011 - Phantom: SAM 1560; Type: SAM; Serial: 1560 - Measurement SW: DASY4, V4.7 Build 80; Postprocessing SW: SEMCAD, V1.8 Build 186</p> <p>Tilt position-high/Zoom Scan (7x7x7)/Cube 0: Measurement grid: dx=5mm, dy=5mm, dz=5mm Reference Value = 13.6 V/m; Power Drift = 0.006 dB Peak SAR (extrapolated) = 0.487 W/kg SAR(1 g) = 0.408 mW/g; SAR(10 g) = 0.312 mW/g Maximum value of SAR (measured) = 0.430 mW/g</p> <div style="display: flex; align-items: center;"> <div style="margin-right: 20px;"> <p>dB</p> <p>0.000</p> <p>-1.80</p> <p>-3.60</p> <p>-5.39</p> <p>-7.19</p> <p>-8.99</p> </div> <div style="text-align: center;">  </div> </div> <p style="text-align: center;">0 dB = 0.430 mW/g</p>		

WCDMA B5 with headset (Flat)

FLAT	Towards ground	826.4 MHz
<p>Communication System: UMTS 835; Frequency: 826.4 MHz; Duty Cycle: 1:1 Medium parameters used (interpolated): $f = 826.4$ MHz; $\sigma = 0.888$ mho/m; $\epsilon_r = 41.9$; $\rho = 1000$ kg/m³ Phantom section: Left Section</p> <p>DASY4 Configuration: - Probe: ES3DV3 - SN3128; ConvF(6.78, 7.02, 6.8); Calibrated: 6/22/2010 - Sensor-Surface: 4mm (Mechanical Surface Detection) - Electronics: DAE4 - SN720; Calibrated: 1/19/2011 - Phantom: SAM 1560; Type: SAM; Serial: 1560 - Measurement SW: DASY4, V4.7 Build 80; Postprocessing SW: SEMCAD, V1.8 Build 186</p> <p>Towards ground - low/Zoom Scan (7x7x7) (7x7x7)/Cube 0: Measurement grid: $dx=5$mm, $dy=5$mm, $dz=5$mm Reference Value = 20.5 V/m; Power Drift = -0.008 dB Peak SAR (extrapolated) = 0.821 W/kg SAR(1 g) = 0.620 mW/g; SAR(10 g) = 0.448 mW/g Maximum value of SAR (measured) = 0.654 mW/g</p> <div data-bbox="140 1265 1173 1803"> <p>dB 0.000 -1.87 -3.74 -5.62 -7.49 -9.36</p> </div> <p>0 dB = 0.654mW/g</p>		

FLAT	Towards ground	836.5 MHz
<p>Communication System: UMTS 835; Frequency: 836.5 MHz; Duty Cycle: 1:1 Medium parameters used (interpolated): $f = 836.5$ MHz; $\sigma = 0.897$ mho/m; $\epsilon_r = 41.6$; $\rho = 1000$ kg/m³ Phantom section: Left Section</p> <p>DASY4 Configuration: - Probe: ES3DV3 - SN3128; ConvF(6.78, 7.02, 6.8); Calibrated: 6/22/2010 - Sensor-Surface: 4mm (Mechanical Surface Detection) - Electronics: DAE4 - SN720; Calibrated: 1/19/2011 - Phantom: SAM 1560; Type: SAM; Serial: 1560 - Measurement SW: DASY4, V4.7 Build 80; Postprocessing SW: SEMCAD, V1.8 Build 186</p> <p>Towards ground - Middle/Zoom Scan (7x7x7) (7x7x7)/Cube 0: Measurement grid: dx=5mm, dy=5mm, dz=5mm Reference Value = 24.8 V/m; Power Drift = -0.104 dB Peak SAR (extrapolated) = 1.12 W/kg SAR(1 g) = 0.847 mW/g; SAR(10 g) = 0.611 mW/g Maximum value of SAR (measured) = 0.894 mW/g</p> <div data-bbox="140 1220 1173 1814"> </div> <p>0 dB = 0.894mW/g</p>		

FLAT	Towards ground	846.6 MHz
<p>Communication System: UMTS 835; Frequency: 846.6 MHz; Duty Cycle: 1:1 Medium parameters used (interpolated): $f = 846.6$ MHz; $\sigma = 0.905$ mho/m; $\epsilon_r = 41.7$; $\rho = 1000$ kg/m³ Phantom section: Left Section</p> <p>DASY4 Configuration: - Probe: ES3DV3 - SN3128; ConvF(6.78, 7.02, 6.8); Calibrated: 6/22/2010 - Sensor-Surface: 4mm (Mechanical Surface Detection) - Electronics: DAE4 - SN720; Calibrated: 1/19/2011 - Phantom: SAM 1560; Type: SAM; Serial: 1560 - Measurement SW: DASY4, V4.7 Build 80; Postprocessing SW: SEMCAD, V1.8 Build 186</p> <p>Towards ground -high/Zoom Scan (7x7x7) (7x7x7)/Cube 0: Measurement grid: dx=5mm, dy=5mm, dz=5mm Reference Value = 22.5 V/m; Power Drift = -0.049 dB Peak SAR (extrapolated) = 0.978 W/kg SAR(1 g) = 0.742 mW/g; SAR(10 g) = 0.536 mW/g Maximum value of SAR (measured) = 0.784 mW/g</p> <div data-bbox="140 1220 1173 1814"> </div> <p>0 dB = 0.784 mW/g</p>		

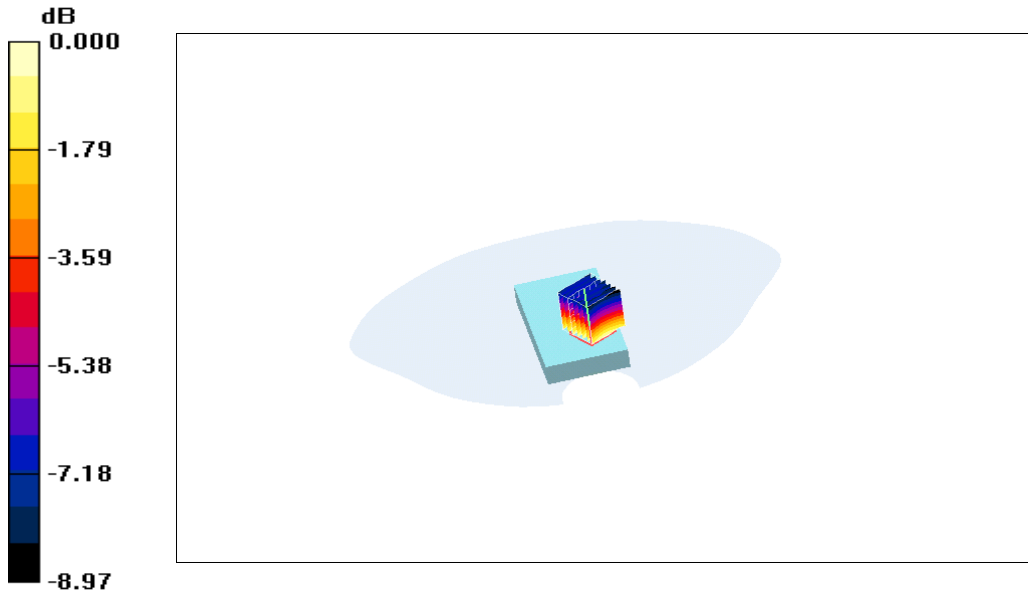
FLAT	Towards phantom	836.5 MHz
<p>Communication System: UMTS 835; Frequency: 836.5 MHz; Duty Cycle: 1:1 Medium parameters used (interpolated): $f = 836.5$ MHz; $\sigma = 0.897$ mho/m; $\epsilon_r = 41.6$; $\rho = 1000$ kg/m³ Phantom section: Left Section</p> <p>DASY4 Configuration: - Probe: ES3DV3 - SN3128; ConvF(6.78, 7.02, 6.8); Calibrated: 6/22/2010 - Sensor-Surface: 4mm (Mechanical Surface Detection) - Electronics: DAE4 - SN720; Calibrated: 1/19/2011 - Phantom: SAM 1560; Type: SAM; Serial: 1560 - Measurement SW: DASY4, V4.7 Build 80; Postprocessing SW: SEMCAD, V1.8 Build 186</p> <p>Towards phantom -middle/Zoom Scan (7x7x7) (7x7x7)/Cube 0: Measurement grid: dx=5mm, dy=5mm, dz=5mm Reference Value = 19.2 V/m; Power Drift = -0.064 dB Peak SAR (extrapolated) = 0.721 W/kg SAR(1 g) = 0.555 mW/g; SAR(10 g) = 0.407 mW/g Maximum value of SAR (measured) = 0.586 mW/g</p>  <p>0 dB = 0.586mW/g</p>		

WCDMA B2 (Head)

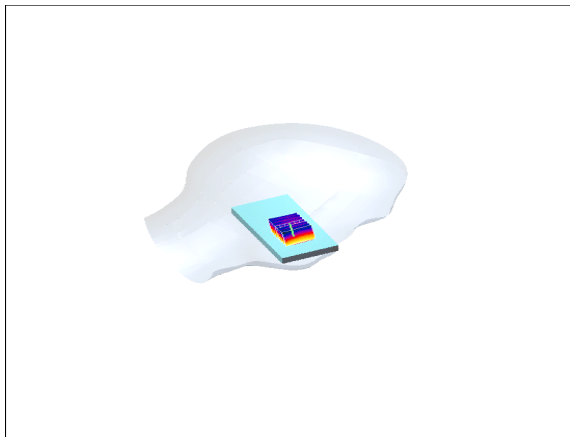
Left Side	Cheek	1852.4 MHz
<p>Communication System: wcdma II; Frequency: 1852.4 MHz; Duty Cycle: 1:1 Medium parameters used (interpolated): $f = 1852.4$ MHz; $\sigma = 1.41$ mho/m; $\epsilon_r = 39.2$; $\rho = 1000$ kg/m³ Phantom section: Left Section</p> <p>DASY4 Configuration: - Probe: ES3DV3 - SN3128; ConvF(4.95, 5.22, 5.06); Calibrated: 6/22/2010 - Sensor-Surface: 4mm (Mechanical Surface Detection) - Electronics: DAE4 - SN720; Calibrated: 1/19/2011 - Phantom: SAM 1560; Type: SAM; Serial: 1560 - Measurement SW: DASY4, V4.7 Build 80; Postprocessing SW: SEMCAD, V1.8 Build 186</p> <p>touch position -low/Zoom Scan (7x7x7)/Cube 0: Measurement grid: dx=5mm, dy=5mm, dz=5mm Reference Value = 16.7 V/m; Power Drift = 0.079 dB Peak SAR (extrapolated) = 1.76 W/kg SAR(1 g) = 1.07 mW/g; SAR(10 g) = 0.608 mW/g Maximum value of SAR (measured) = 1.19 mW/g</p> <div style="display: flex; align-items: center;"> <div style="margin-right: 20px;"> <p>dB</p> <p>0.000</p> <p>-2.80</p> <p>-5.60</p> <p>-8.40</p> <p>-11.2</p> <p>-14.0</p> </div> <div style="flex-grow: 1;">  </div> </div> <p style="text-align: center;">0 dB = 1.19mW/g</p>		

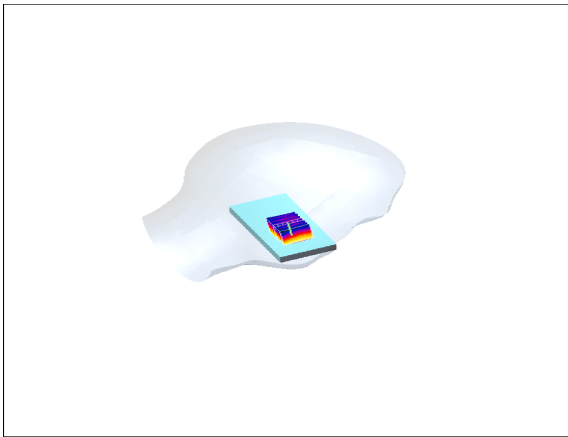
Left Side	Cheek	1880 MHz
<p>Communication System: wcdma II; Frequency: 1880 MHz; Duty Cycle: 1:1 Medium parameters used: $f = 1880$ MHz; $\sigma = 1.44$ mho/m; $\epsilon_r = 39$; $\rho = 1000$ kg/m³ Phantom section: Left Section</p> <p>DASY4 Configuration: - Probe: ES3DV3 - SN3128; ConvF(4.95, 5.22, 5.06); Calibrated: 6/22/2010 - Sensor-Surface: 4mm (Mechanical Surface Detection) - Electronics: DAE4 - SN720; Calibrated: 1/19/2011 - Phantom: SAM 1560; Type: SAM; Serial: 1560 - Measurement SW: DASY4, V4.7 Build 80; Postprocessing SW: SEMCAD, V1.8 Build 186</p> <p>Touch position - Middle/Zoom Scan (7x7x7) (7x7x7)/Cube 0: Measurement grid: dx=5mm, dy=5mm, dz=5mm Reference Value = 9.04 V/m; Power Drift = 0.072 dB Peak SAR (extrapolated) = 1.56 W/kg SAR(1 g) = 0.972 mW/g; SAR(10 g) = 0.579 mW/g Maximum value of SAR (measured) = 1.06 mW/g</p> <div style="display: flex; align-items: center;"> <div style="margin-right: 20px;"> <p>dB</p> <p>0.000</p> <p>-2.64</p> <p>-5.28</p> <p>-7.92</p> <p>-10.6</p> <p>-13.2</p> </div> <div style="text-align: center;">  </div> </div> <p style="text-align: center;">0 dB = 1.06mW/g</p>		

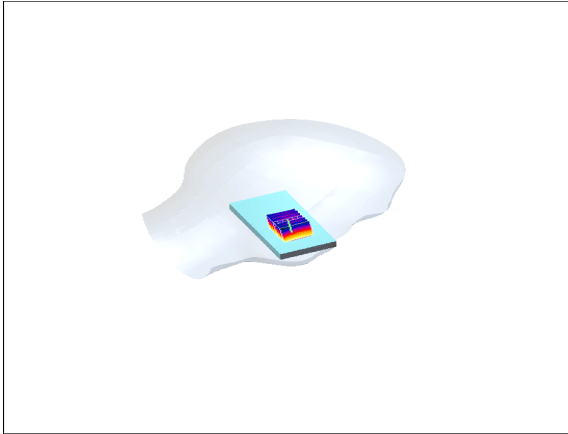
Left Side	Cheek	1907.6 MHz
<p>Communication System: wcdma II; Frequency: 1907.6 MHz; Duty Cycle: 1:1 Medium parameters used (interpolated): $f = 1907.6 \text{ MHz}$; $\sigma = 1.46 \text{ mho/m}$; $\epsilon_r = 38.9$; $\rho = 1000 \text{ kg/m}^3$ Phantom section: Left Section</p> <p>DASY4 Configuration: - Probe: ES3DV3 - SN3128; ConvF(4.95, 5.22, 5.06); Calibrated: 6/22/2010 - Sensor-Surface: 4mm (Mechanical Surface Detection) - Electronics: DAE4 - SN720; Calibrated: 1/19/2011 - Phantom: SAM 1560; Type: SAM; Serial: 1560 - Measurement SW: DASY4, V4.7 Build 80; Postprocessing SW: SEMCAD, V1.8 Build 186</p> <p>touch position-high-2/Zoom Scan (7x7x7)/Cube 0: Measurement grid: dx=5mm, dy=5mm, dz=5mm Reference Value = 16.8 V/m; Power Drift = -0.104 dB Peak SAR (extrapolated) = 1.33 W/kg SAR(1 g) = 0.822 mW/g; SAR(10 g) = 0.479 mW/g Maximum value of SAR (measured) = 0.902 mW/g</p>		
<div style="display: flex; align-items: center;"> <div style="margin-right: 20px;"> <p>dB</p> <p>0.000</p> <p>-2.90</p> <p>-5.80</p> <p>-8.70</p> <p>-11.6</p> <p>-14.5</p> </div> <div style="text-align: center;">  <p>0 dB = 0.902mW/g</p> </div> </div>		

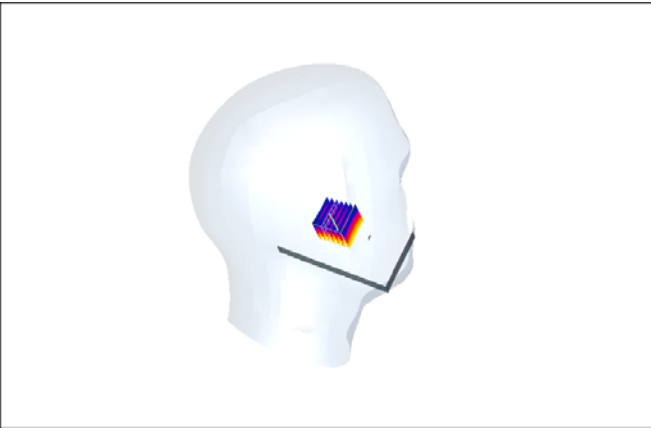
Left Side	Tilt	1852.4 MHz
<p>Communication System: wcdma II; Frequency: 1852.4 MHz;Duty Cycle: 1:1 Medium parameters used (interpolated): $f = 1852.4$ MHz; $\sigma = 1.41$ mho/m; $\epsilon_r = 39.2$; $\rho = 1000$ kg/m³ Phantom section: Left Section</p> <p>DASY4 Configuration: - Probe: ES3DV3 - SN3128; ConvF(4.95, 5.22, 5.06); Calibrated: 6/22/2010 - Sensor-Surface: 4mm (Mechanical Surface Detection) - Electronics: DAE4 - SN720; Calibrated: 1/19/2011 - Phantom: SAM 1560; Type: SAM; Serial: 1560 - Measurement SW: DASY4, V4.7 Build 80; Postprocessing SW: SEMCAD, V1.8 Build 186</p> <p>Tilt position -low/Zoom Scan (7x7x7)/Cube 0: Measurement grid: dx=5mm, dy=5mm, dz=5mm Reference Value = 21.9 V/m; Power Drift = 0.027 dB Peak SAR (extrapolated) = 1.17 W/kg SAR(1 g) = 0.748 mW/g; SAR(10 g) = 0.448 mW/g Maximum value of SAR (measured) = 0.817 mW/g</p>		
<div style="display: flex; align-items: center;"> <div style="margin-right: 20px;"> <p>dB</p> <p>0.000</p> <p>-1.83</p> <p>-3.66</p> <p>-5.48</p> <p>-7.31</p> <p>-9.14</p> </div> <div style="flex-grow: 1;">  </div> </div> <p style="text-align: center;">0 dB =0.817mW/g</p>		

Left Side	Tilt	1880 MHz
<p>Communication System: wcdma II; Frequency: 1880 MHz; Duty Cycle: 1:1 Medium parameters used: $f = 1880$ MHz; $\sigma = 1.44$ mho/m; $\epsilon_r = 39$; $\rho = 1000$ kg/m³ Phantom section: Left Section</p> <p>DASY4 Configuration: - Probe: ES3DV3 - SN3128; ConvF(4.95, 5.22, 5.06); Calibrated: 6/22/2010 - Sensor-Surface: 4mm (Mechanical Surface Detection) - Electronics: DAE4 - SN720; Calibrated: 1/19/2011 - Phantom: SAM 1560; Type: SAM; Serial: 1560 - Measurement SW: DASY4, V4.7 Build 80; Postprocessing SW: SEMCAD, V1.8 Build 186</p> <p>Tilt position-middle/Zoom Scan (7x7x7)/Cube 0: Measurement grid: dx=5mm, dy=5mm, dz=5mm Reference Value = 21.5 V/m; Power Drift = -0.075 dB Peak SAR (extrapolated) = 1.07 W/kg SAR(1 g) = 0.686 mW/g; SAR(10 g) = 0.413 mW/g Maximum value of SAR (measured) = 0.749 mW/g</p>		
<div style="display: flex; align-items: center;"> <div style="margin-right: 20px;"> <p>dB</p> <p>0.000 -1.83 -3.66 -5.48 -7.31 -9.14</p> </div> <div style="text-align: center;"> </div> </div> <p style="text-align: center; margin-top: 10px;">0 dB = 0.749mW/g</p>		

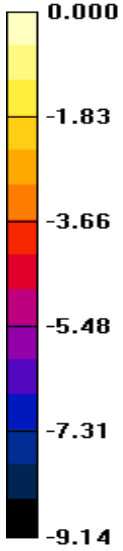
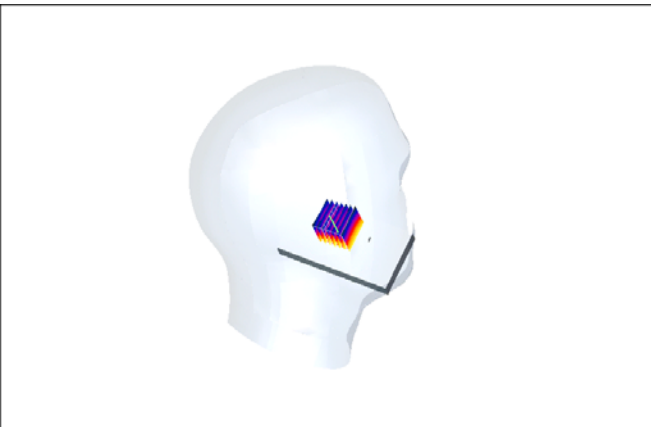
Left Side	Tilt	1907.6 MHz
<p>Communication System: wcdma II; Frequency: 1907.6 MHz; Duty Cycle: 1:1 Medium parameters used (interpolated): $f = 1907.6$ MHz; $\sigma = 1.46$ mho/m; $\epsilon_r = 38.9$; $\rho = 1000$ kg/m³ Phantom section: Left Section</p> <p>DASY4 Configuration: - Probe: ES3DV3 - SN3128; ConvF(4.95, 5.22, 5.06); Calibrated: 6/22/2010 - Sensor-Surface: 4mm (Mechanical Surface Detection) - Electronics: DAE4 - SN720; Calibrated: 1/19/2011 - Phantom: SAM 1560; Type: SAM; Serial: 1560 - Measurement SW: DASY4, V4.7 Build 80; Postprocessing SW: SEMCAD, V1.8 Build 186</p> <p>Tilt position-high/Zoom Scan (7x7x7)/Cube 0: Measurement grid: dx=5mm, dy=5mm, dz=5mm Reference Value = 22.3 V/m; Power Drift = 0.000 dB Peak SAR (extrapolated) = 0.988 W/kg SAR(1 g) = 0.655 mW/g; SAR(10 g) = 0.406 mW/g Maximum value of SAR (measured) = 0.711 mW/g</p>		
<div style="display: flex; align-items: center;"> <div style="margin-right: 20px;"> <p>dB</p> <p>0.000</p>  <p>-1.83</p> <p>-3.66</p> <p>-5.48</p> <p>-7.31</p> <p>-9.14</p> </div> <div style="text-align: center;">  <p>0 dB = 0.711mW/g</p> </div> </div>		

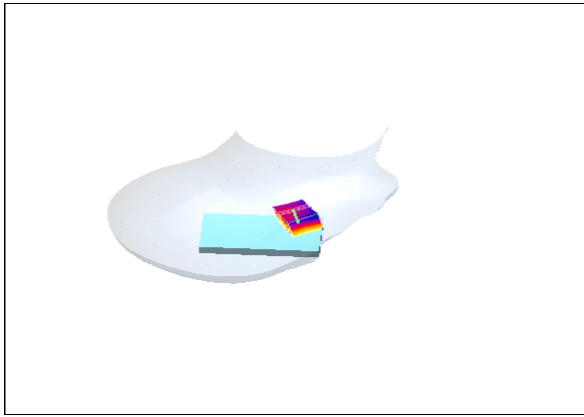
Right Side	Cheek	1852.4MHz
<p>Communication System: wcdma II; Frequency: 1852.4 MHz; Duty Cycle: 1:1 Medium parameters used (interpolated): $f = 1852.4$ MHz; $\sigma = 1.41$ mho/m; $\epsilon_r = 39.2$; $\rho = 1000$ kg/m³ Phantom section: Left Section</p> <p>DASY4 Configuration: - Probe: ES3DV3 - SN3128; ConvF(4.95, 5.22, 5.06); Calibrated: 6/22/2010 - Sensor-Surface: 4mm (Mechanical Surface Detection) - Electronics: DAE4 - SN720; Calibrated: 1/19/2011 - Phantom: SAM 1560; Type: SAM; Serial: 1560 - Measurement SW: DASY4, V4.7 Build 80; Postprocessing SW: SEMCAD, V1.8 Build 186</p> <p>Touch position/Zoom Scan (7x7x7)/Cube 0: Measurement grid: dx=5mm, dy=5mm, dz=5mm Reference Value = 21.6 V/m; Power Drift = -0.076 dB Peak SAR (extrapolated) = 2.00 W/kg SAR(1 g) = 1.23 mW/g; SAR(10 g) = 0.736 mW/g Maximum value of SAR (measured) = 1.33 mW/g</p> <div style="display: flex; align-items: center;"> <div style="margin-right: 20px;"> <p>dB</p> <p>0.000</p> <p>-2.16</p> <p>-4.32</p> <p>-6.48</p> <p>-8.64</p> <p>-10.8</p> </div> <div style="flex-grow: 1;">  </div> </div> <p style="text-align: center;">0 dB = 1.33mW/g</p>		

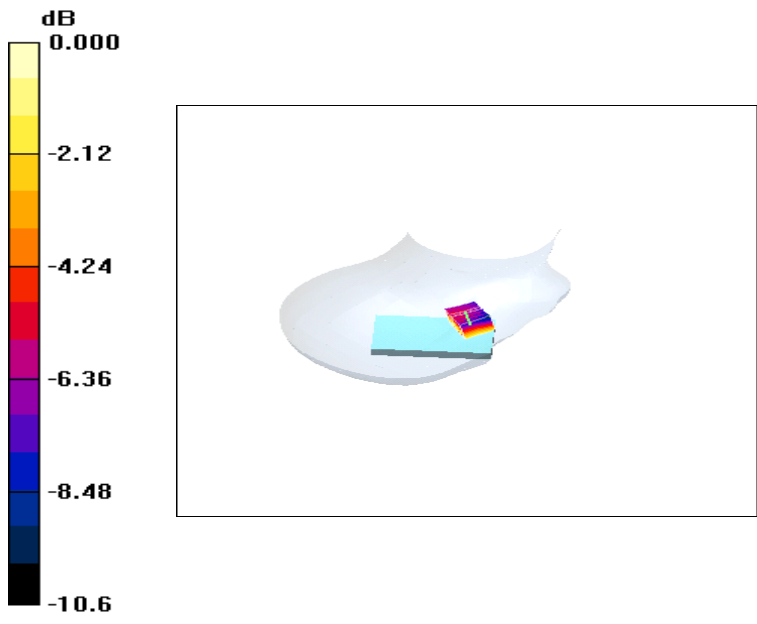
Right Side	Cheek	1880MHz
<p>Communication System: UMTS 835; Frequency: 836.5 MHz; Duty Cycle: 1:1 Medium parameters used (interpolated): $f = 836.5$ MHz; $\sigma = 0.897$ mho/m; $\epsilon_r = 41.6$; $\rho = 1000$ kg/m³ Phantom section: Left Section</p> <p>DASY4 Configuration: - Probe: ES3DV3 - SN3128; ConvF(4.95, 5.22, 5.06); Calibrated: 6/22/2010 - Sensor-Surface: 4mm (Mechanical Surface Detection) - Electronics: DAE4 - SN720; Calibrated: 1/19/2011 - Phantom: SAM 1560; Type: SAM; Serial: 1560 - Measurement SW: DASY4, V4.7 Build 80; Postprocessing SW: SEMCAD, V1.8 Build 186</p> <p>Touch position - Middle/Zoom Scan (7x7x7) (7x7x7)/Cube 0: Measurement grid: dx=5mm, dy=5mm, dz=5mm Reference Value = 22.4 V/m; Power Drift = -0.046 dB Peak SAR (extrapolated) = 1.59 W/kg SAR(1 g) = 1 mW/g; SAR(10 g) = 0.623 mW/g Maximum value of SAR (measured) = 1.10 mW/gg</p>		
 <p style="text-align: center;">0 dB = 1.10mW/g</p>		

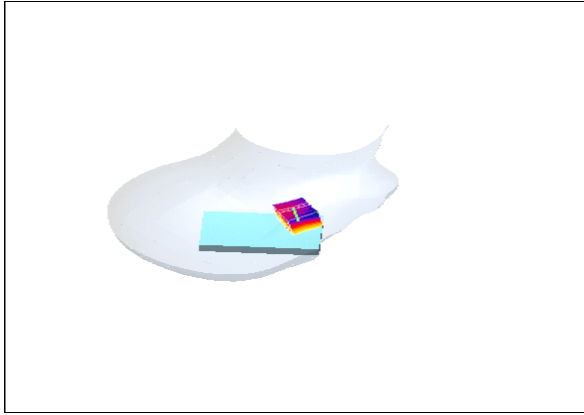
Right Side	Cheek	1907.6 MHz
<p>Communication System: wcdma II; Frequency: 1907.6 MHz; Duty Cycle: 1:1 Medium parameters used (interpolated): $f = 1907.6$ MHz; $\sigma = 1.46$ mho/m; $\epsilon_r = 38.9$; $\rho = 1000$ kg/m³ Phantom section: Right Section</p> <p>DASY4 Configuration: - Probe: ES3DV3 - SN3128; ConvF(4.95, 5.22, 5.06); Calibrated: 6/22/2010 - Sensor-Surface: 4mm (Mechanical Surface Detection) - Electronics: DAE - SN720; Calibrated: 1/19/2011 - Phantom: SAM 1559; Type: SAM; Serial: 1559 - Measurement SW: DASY4, V4.7 Build 80; Postprocessing SW: SEMCAD, V1.8 Build 186</p> <p>Touch high/Zoom Scan (7x7x7)/Cube 0: Measurement grid: dx=5mm, dy=5mm, dz=5mm Reference Value = 19.1 V/m; Power Drift = -0.039 dB Peak SAR (extrapolated) = 1.62 W/kg SAR(1 g) = 1.03 mW/g; SAR(10 g) = 0.634 mW/g Maximum value of SAR (measured) = 1.12 mW/g</p> <div style="display: flex; align-items: center;"> <div style="margin-right: 20px;"> <p>dB</p> <p>0.000</p> <p>-2.40</p> <p>-4.80</p> <p>-7.20</p> <p>-9.60</p> <p>-12.0</p> </div> <div style="flex-grow: 1;">  </div> </div> <p style="text-align: center;">0 dB = 1.12mW/g</p>		

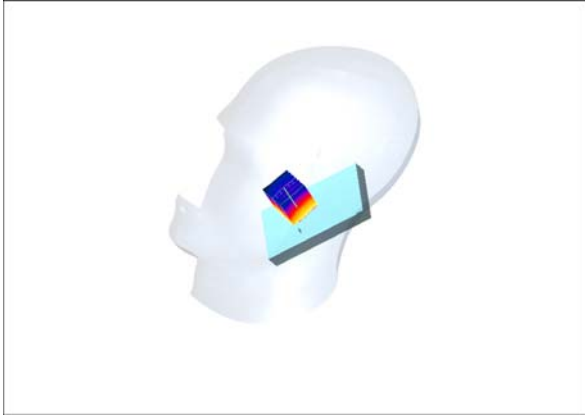
Right Side	Tilt	1852.4MHz
<p>Communication System: wcdma II; Frequency: 1852.4 MHz; Duty Cycle: 1:1 Medium parameters used (interpolated): $f = 1852.4$ MHz; $\sigma = 1.41$ mho/m; $\epsilon_r = 39.2$; $\rho = 1000$ kg/m³ Phantom section: Left Section</p> <p>DASY4 Configuration: - Probe: ES3DV3 - SN3128; ConvF(4.95, 5.22, 5.06); Calibrated: 6/22/2010 - Sensor-Surface: 4mm (Mechanical Surface Detection) - Electronics: DAE4 - SN720; Calibrated: 1/19/2011 - Phantom: SAM 1560; Type: SAM; Serial: 1560 - Measurement SW: DASY4, V4.7 Build 80; Postprocessing SW: SEMCAD, V1.8 Build 186</p> <p>Tilt position -low/Zoom Scan (7x7x7)/Cube 0: Measurement grid: dx=5mm, dy=5mm, dz=5mm Reference Value = 21.3 V/m; Power Drift = 0.010 dB Peak SAR (extrapolated) = 0.858 W/kg SAR(1 g) = 0.570 mW/g; SAR(10 g) = 0.350 mW/g Maximum value of SAR (measured) = 0.622 mW/g</p> <div style="display: flex; align-items: center;"> <div style="margin-right: 20px;"> <p>dB</p> <p>0.000</p> <p>-1.80</p> <p>-3.60</p> <p>-5.39</p> <p>-7.19</p> <p>-8.99</p> </div> <div style="text-align: center;">  </div> </div> <p style="text-align: center;">0 dB = 0.419 mW/g</p>		

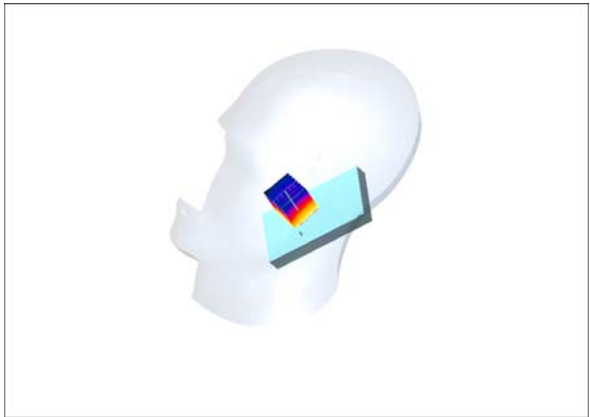
Right Side	Tilt	1880 MHz
<p>Communication System: wcdma II; Frequency: 1880 MHz; Duty Cycle: 1:1 Medium parameters used: $f = 1880$ MHz; $\sigma = 1.44$ mho/m; $\epsilon_r = 39$; $\rho = 1000$ kg/m³ Phantom section: Left Section</p> <p>DASY4 Configuration: - Probe: ES3DV3 - SN3128; ConvF(4.95, 5.22, 5.06); Calibrated: 6/22/2010 - Sensor-Surface: 4mm (Mechanical Surface Detection) - Electronics: DAE4 - SN720; Calibrated: 1/19/2011 - Phantom: SAM 1560; Type: SAM; Serial: 1560 - Measurement SW: DASY4, V4.7 Build 80; Postprocessing SW: SEMCAD, V1.8 Build 186</p> <p>Tilt position-middle/Zoom Scan (7x7x7)/Cube 0: Measurement grid: dx=5mm, dy=5mm, dz=5mm Reference Value = 21.1 V/m; Power Drift = 0.026 dB Peak SAR (extrapolated) = 0.853 W/kg SAR(1 g) = 0.583 mW/g; SAR(10 g) = 0.368 mW/g Maximum value of SAR (measured) = 0.629 mW/g</p> <div style="display: flex; align-items: center;"> <div style="margin-right: 20px;"> <p>dB</p> <p>0.000</p> <p>-1.80</p> <p>-3.60</p> <p>-5.39</p> <p>-7.19</p> <p>-8.99</p> </div> <div style="text-align: center;">  </div> </div> <p style="text-align: center;">0 dB = 0.629 mW/g</p>		

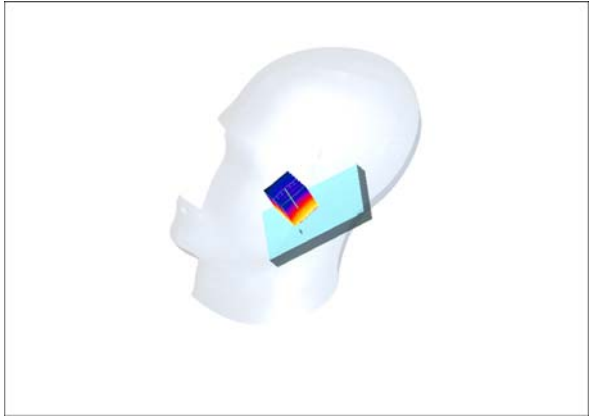
Right Side	Tilt	1907.6 MHz
<p>Communication System: wcdma II; Frequency: 1907.6 MHz; Duty Cycle: 1:1 Medium parameters used (interpolated): $f = 1907.6$ MHz; $\sigma = 1.46$ mho/m; $\epsilon_r = 38.9$; $\rho = 1000$ kg/m³ Phantom section: Right Section</p> <p>DASY4 Configuration: - Probe: ES3DV3 - SN3128; ConvF(4.95, 5.22, 5.06); Calibrated: 6/22/2010 - Sensor-Surface: 4mm (Mechanical Surface Detection) - Electronics: DAE - SN720; Calibrated: 1/19/2011 - Phantom: SAM 1559; Type: SAM; Serial: 1559 - Measurement SW: DASY4, V4.7 Build 80; Postprocessing SW: SEMCAD, V1.8 Build 186</p> <p>Tilt position-high/Zoom Scan (7x7x7)/Cube 0: Measurement grid: dx=5mm, dy=5mm, dz=5mm Reference Value = 21.8 V/m; Power Drift = -0.233 dB Peak SAR (extrapolated) = 1.06 W/kg SAR(1 g) = 0.684 mW/g; SAR(10 g) = 0.409 mW/g Maximum value of SAR (measured) = 0.757 mW/g</p> <div style="display: flex; align-items: center;"> <div style="margin-right: 20px;"> <p>dB</p> <p>0.000</p> <p>-1.80</p> <p>-3.60</p> <p>-5.39</p> <p>-7.19</p> <p>-8.99</p> </div> <div style="flex-grow: 1;">  </div> </div> <p style="text-align: center;">0 dB = 0.757 mW/g</p>		

WCDMA B5 with headset (Flat)

FLAT	Towards ground	1852.4 MHz
<p>Communication System: wcdma II; Frequency: 1852.4 MHz; Duty Cycle: 1:1 Medium parameters used (interpolated): $f = 1852.4$ MHz; $\sigma = 1.54$ mho/m; $\epsilon_r = 53.7$; $\rho = 1000$ kg/m³ Phantom section: Flat Section</p> <p>DASY4 Configuration: - Probe: ES3DV3 - SN3128; ConvF(4.53, 4.79, 4.63); Calibrated: 6/22/2010 - Sensor-Surface: 4mm (Mechanical Surface Detection) - Electronics: DAE - SN720; Calibrated: 1/19/2011 - Phantom: SAM 1559; Type: SAM; Serial: 1559 - Measurement SW: DASY4, V4.7 Build 80; Postprocessing SW: SEMCAD, V1.8 Build 186</p> <p>Towards ground - low/Zoom Scan (7x7x7) (7x7x7)/Cube 0: Measurement grid: $dx=5$mm, $dy=5$mm, $dz=5$mm Reference Value = 12.1 V/m; Power Drift = 0.032 dB Peak SAR (extrapolated) = 1.67 W/kg SAR(1 g) = 1.02 mW/g; SAR(10 g) = 0.597 mW/g Maximum value of SAR (measured) = 1.11 mW/g</p> <div data-bbox="140 1265 1173 1803"> </div>		

FLAT	Towards ground	1880 MHz
<p>Communication System: wcdma II; Frequency: 1880 MHz; Duty Cycle: 1:1 Medium parameters used: $f = 1880$ MHz; $\sigma = 1.57$ mho/m; $\epsilon_r = 53.5$; $\rho = 1000$ kg/m³ Phantom section: Flat Section</p> <p>DASY4 Configuration: - Probe: ES3DV3 - SN3128; ConvF(4.53, 4.79, 4.63); Calibrated: 6/22/2010 - Sensor-Surface: 4mm (Mechanical Surface Detection) - Electronics: DAE - SN720; Calibrated: 1/19/2011 - Phantom: SAM 1559; Type: SAM; Serial: 1559 - Measurement SW: DASY4, V4.7 Build 80; Postprocessing SW: SEMCAD, V1.8 Build 186</p> <p>Towards ground -middle/Zoom Scan (7x7x7) (7x7x7)/Cube 0: Measurement grid: dx=5mm, dy=5mm, dz=5mm Reference Value = 14.0 V/m; Power Drift = -0.021 dB Peak SAR (extrapolated) = 1.58 W/kg SAR(1 g) = 0.963 mW/g; SAR(10 g) = 0.567 mW/g Maximum value of SAR (measured) = 1.05 mW/g</p> <div data-bbox="140 1176 1173 1825">  <p>0 dB = 1.05mW/g</p> </div>		

FLAT	Towards ground	1907.6 MHz
<p>Communication System: wcdma II; Frequency: 1907.6 MHz; Duty Cycle: 1:1 Medium parameters used (interpolated): $f = 1907.6$ MHz; $\sigma = 1.59$ mho/m; $\epsilon_r = 53.5$; $\rho = 1000$ kg/m³ Phantom section: Flat Section</p> <p>DASY4 Configuration: - Probe: ES3DV3 - SN3128; ConvF(4.53, 4.79, 4.63); Calibrated: 6/22/2010 - Sensor-Surface: 4mm (Mechanical Surface Detection) - Electronics: DAE - SN720; Calibrated: 1/19/2011 - Phantom: SAM 1559; Type: SAM; Serial: 1559 - Measurement SW: DASY4, V4.7 Build 80; Postprocessing SW: SEMCAD, V1.8 Build 186</p> <p>Towards ground -high/Zoom Scan (7x7x7) (7x7x7)/Cube 0: Measurement grid: dx=5mm, dy=5mm, dz=5mm Reference Value = 11.4 V/m; Power Drift = 0.036 dB Peak SAR (extrapolated) = 1.31 W/kg SAR(1 g) = 0.804 mW/g; SAR(10 g) = 0.476 mW/g Maximum value of SAR (measured) = 0.868 mW/g</p> <div data-bbox="140 1220 1173 1814"> </div> <p>0 dB = 0.868 mW/g</p>		

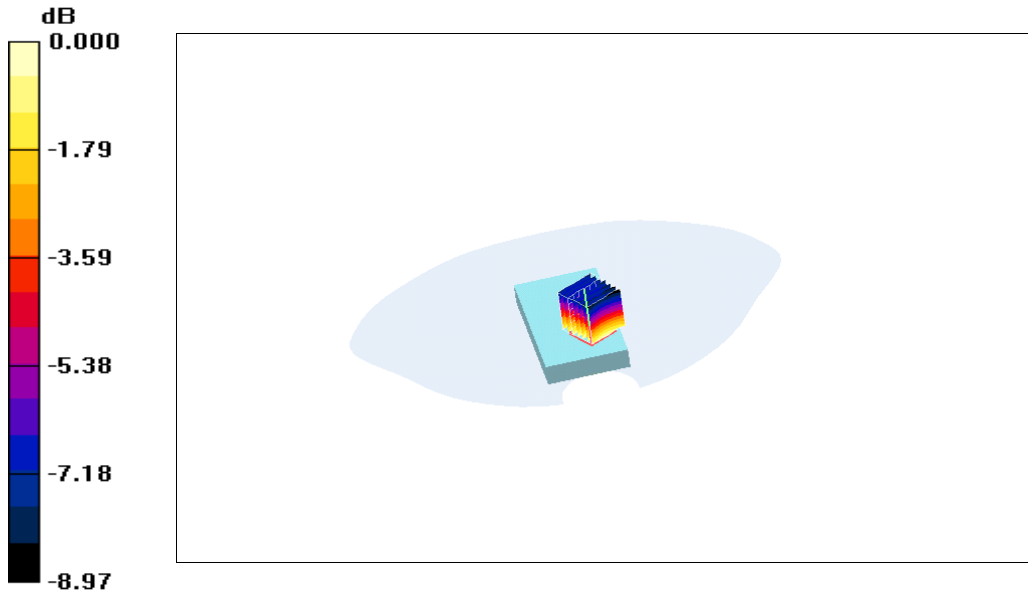
FLAT	Towards phantom	1880 MHz
<p>Communication System: wcdma II; Frequency: 1880 MHz; Duty Cycle: 1:1 Medium parameters used: $f = 1880$ MHz; $\sigma = 1.57$ mho/m; $\epsilon_r = 53.5$; $\rho = 1000$ kg/m³ Phantom section: Flat Section</p> <p>DASY4 Configuration: - Probe: ES3DV3 - SN3128; ConvF(4.53, 4.79, 4.63); Calibrated: 6/22/2010 - Sensor-Surface: 4mm (Mechanical Surface Detection) - Electronics: DAE - SN720; Calibrated: 1/19/2011 - Phantom: SAM 1559; Type: SAM; Serial: 1559 - Measurement SW: DASY4, V4.7 Build 80; Postprocessing SW: SEMCAD, V1.8 Build 186</p> <p>Towards phantom - Middle/Zoom Scan (7x7x7) (7x7x7)/Cube 0: Measurement grid: dx=5mm, dy=5mm, dz=5mm Reference Value = 13.6 V/m; Power Drift = 0.000 dB Peak SAR (extrapolated) = 1.09 W/kg SAR(1 g) = 0.678 mW/g; SAR(10 g) = 0.399 mW/g Maximum value of SAR (measured) = 0.734 mW/g</p>  <p>0 dB = 0.734mW/g</p>		

APPENDIX C: RELEVANT PAGES FROM PROBE CALIBRATION REPORT(S)

The State Radio_monitoring_center Testing Center

Calibration Certificate



CALIBRATION
CNAS L0447

Instrument	Dosimetric E-field Probe
Type/Model	ES3DV3
Manufacturer	Schmid & Partner Engineering AG
Serial No	SN:3128
Name of Client	The State Radio_monitoring_center Testing Center
Address of Client	No.98 Bei Lishi Road XiCheng District
Calibration Date	2010.6.22

All calibrations have been conducted in the closed laboratory facility: environment temperature (22±3) °C and humidity<70%

Approved by  

Tel: +86-10-68009202 68009203 Fax: +86-10-68009205 68009195
Add: No.80 Bei Lishi Road, Xi Cheng District Beijing 100037, P.R.China

Page 1 of 6 Certificate No.SRTC2010-CAL002-004

The State Radio_monitoring_center Testing Center

Reference documents of the measurement(Code, Name) SRTC3003-V1.0.0 Working procedure for calibration——SAR testing system
Place and environmental condition of the measurement Temperature 22.1℃ Humidity 24.8% Location SRTC226 room

Primary Calibration Equipment used	Model/Type	ID#	Cal Date	Scheduled Calibration
Power meter	E4417A	SN: MY45101004	2009.8	2010.8
Power sensor	E9300B	SN: MY41496001	2009.8	2010.8
Power sensor	E9300B	SN: MY41496003	2009.8	2010.8
Reference DAE	DAE4	SN: 720	2010.1	2011.1
Signal generator	SML03	SN:103514	2009.8	2010.8
Network analyzer	8714ET	SN:US40372083	2009.8	2010.8
Secondary Calibration Equipment used	Model/Type	ID#		
Waveguide	WGLS R9	SN:1006		
Waveguide	WGLS R14	SN:1003		
Waveguide	WGLS R22	SN:1006		

The State Radio_monitoring_center Testing Center

Note:

1. This calibration certificate documents the traceability to national standards, which realize the physical units of measurements (SI).
The measurements and the uncertainties with confidence probability are given on the following pages and are part of the certificate.
2. This calibration certificate is not permitted to be reproduced except in full without written the approval of the only laboratory
3. SRTC is responsible for the whole of certificate only with stamp of SRTC.
4. The calibration results would be valid only for the items calibration.
5. The certification is written by Chinese and English. Exact meaning should be explained only on Chinese version.

Tel: +86-10-68009202 68009203 Fax: +86-10-68009205 68009195
Add: No.80 Bei Lishi Road, Xi Cheng District Beijing 100037, P.R.China

Page 3 of 6 Certificate No.SRTC2010-CAL002-004

The State Radio_monitoring_center Testing Center

Glossary

TSL	Tissue Simulating Liquid
NORM _{x, y, z}	The sensitivity in free space
ConvF	The sensitivity of the TSL/The sensitivity in free space
DCP	Diode Compression Point
Angle ϕ	ϕ rotation around probe axis
Angle θ	θ rotation around an axis that is in the plane normal to probe axis i.e. $\theta=0$, means that is normal to probe axis

Calibration is preformed according to the Following Standards

IEEE Std 1528-2003
IEC 62209-1-2005
Federal Communication Commission Office of Engineering & Technology (FCC OET)

Methods Applied and Interpretation of Parameters

- NORM_{x, y, z}: Assessed for E-field polarization $\theta=0$ for XY sensors and $\theta=90$ for Z sensor
- NORM(f)_{x, y, z}= NORM_{x, y, z} * frequency_response. And this linearization is implemented in DASY4 software versions later than 4.2. The uncertainty of the frequency response is included in the states uncertainty of ConvF.
- DCP_{x,y,z}: DCP are numerical linearization parameters assessed based on the data of power sweep(no uncertainty required). DCP does not depend on frequency and medium.
- ConvF and boundary effect: Assessed in flat phantom using E-field and inside waveguide using analytical field distributions based on power measurements for $f > 800\text{MHz}$.The same setups are used for assessment of the parameters applied for boundary compensation(alpha,depth)of which typical uncertainty values are given. A frequency dependent ConvF is used in DASY version 4.4 and higher which allows extending the validity from $\pm 50\text{MHz}$ to $\pm 100\text{MHz}$.
- Spherical isotropy: in a locally homogeneous field realized using an open waveguide setup.

Tel: +86-10-68009202 68009203 Fax: +86-10-68009205 68009195
Add: No.80 Bei Lishi Road, Xi Cheng District Beijing 100037, P.R .China

Page 4 of 6 Certificate No.SRTC2010-CAL002-004

The State Radio_monitoring_center Testing Center

Measurement Conditions

DASY versions	DSAY 5	V5.0 Build 126
Model	Flat phantom	—

Probe Sensitivity Parameters

	Value	Unit
Axis X	1.00	$\mu V / (V / m)^2$
Axis Y	1.00	$\mu V / (V / m)^2$
Axis Z	1.00	$\mu V / (V / m)^2$

1. Diode Compression Point

	Value	Unit	Uncertainty (k=2)
Axis X	97.4	mV	10.82%
Axis Y	101.4	mV	10.82%
Axis Z	100.7	mV	10.82%

2. Probe Conversion Factors: Head Tissue Liquid

Frequency (MHz)	Validity (MHz)	Permittivity	Conductivity (mho/m)	Alpha	Depth (mm)	ConvFx / ConvFy / ConvFz	ConvFx / ConvFy / ConvFz	ConvFx / ConvFy / ConvFz	Uncertainty (k = 2)
835	±100	41.93	0.916	0.448	1.499	7.880	8.301	8.050	13.02%
900	±100	42.72	0.968	0.607	1.271	9.029	9.525	9.201	13.02%
1800	±100	39.61	1.354	0.312	2.126	6.154	6.495	6.273	13.02%
1900	±100	39.11	1.463	0.381	1.832	4.947	5.220	5.055	13.02%

The State Radio_monitoring_center Testing Center

3. Probe Conversion Factors: Body Tissue Liquid

Frequency (MHz)	Validity (MHz)	Permittivity	Conductivity (mho/m)	Alpha	Depth (mm)	ConvFx/ ConvFy/ConvFz			Uncertainty (k = 2)
						$\mu V / (V / m)^2$			
835	±100	54.05	0.983	0.508	1.412	6.776	7.019	6.804	13.02%
900	±100	54.48	1.055	0.672	1.244	8.755	9.243	8.919	13.02%
1800	±100	53.74	1.567	0.316	2.446	5.702	6.018	5.816	13.02%
1900	±100	54.42	1.465	0.330	2.414	4.532	4.785	4.632	13.02%

4. Probe Isotropy

	Value	Unit	Uncertainty(k=2)
Axial Isotropy	-0.071	dB	10.18%
Spherical Isotropy	-0.171	dB	10.18%

Calibrated by 张明远

Checked by 刘 梅

APPENDIX D: RELEVANT PAGES FROM DIPOLE VALIDATION KIT REPORT(S)

The State Radio_monitoring_center Testing Center

Calibration Certificate



Instrument Dipole

Type/Model D900V2

Manufacturer Schmid & Partner Engineering AG

Serial No SN:171

Name of Client The State Radio_monitoring_center Testing Center

Address of Client No.98 Bei Lishi Road XiCheng District

Calibration Date 2010.6.11

All calibrations have been conducted in the closed laboratory facility: environment temperature (22±3) °C and humidity<70%

Approved by  

Tel: +86-10-68009202 68009203 Fax: +86-10-68009205 68009195
Add: No.80 Bei Lishi Road, Xi Cheng District Beijing 100037, P.R.China

Page 1 of 8 Certificate No.SRTC2010-CAL003-003

The State Radio_monitoring_center Testing Center

Reference documents of the measurement(Code, Name)
SRTC3003-V1.0.0 Working procedure for calibration of SAR Testing system
Place and environmental condition of the measurement
Temperature 21.6℃ Humidity 30.7%
Location SRTC Room226

Primary Calibration Equipment used	Model/Type	ID#	Cal Date	Scheduled Calibration
Power meter	E4417A	SN: MY45101004	2009.8	2010.8
Power sensor	E9300B	SN: MY41496001	2009.8	2010.8
Power sensor	E9300B	SN: MY41496003	2009.8	2010.8
Reference DAE	DAE4	SN: 720	2010.1	2011.1
Reference probe	ES3DV3	SN: 3128	2009.6	2010.6
Secondary Calibration Equipment used	Model/Type	ID#	Cal Date	Scheduled Calibration
Signal generator	SML03	SN:103514	2009.8	2010.8
Network analyzer	8714ET	SN:US40372083	2009.8	2010.8

Tel: +86-10-68009202 68009203 Fax: +86-10-68009205 68009195
Add: No.80 Bei Lishi Road, Xi Cheng District Beijing 100037, P.R. China

Page 2 of 8 Certificate No.SRTC2010-CAL003-003

The State Radio_monitoring_center Testing Center

Note:

1. This calibration certificate documents the traceability to national standards, which realize the physical units of measurements (SI).
The measurements and the uncertainties with confidence probability are given on the following pages and are part of the certificate.
2. This calibration certificate is not permitted to be reproduced except in full without written the approval of the only laboratory
3. SRTC is responsible for the whole of certificate only with stamp of SRTC.
4. The calibration results would be valid only for the items calibration.
5. The certification is written by Chinese and English. Exact meaning should be explained only on Chinese version.

Tel: +86-10-68009202 68009203 Fax: +86-10-68009205 68009195
Add: No.80 Bei Lishi Road, Xi Cheng District Beijing 100037, P.R. China

Page 3 of 8 Certificate No.SRTC2010-CAL003-003

The State Radio_monitoring_center Testing Center

Glossary

TSL	Tissue Simulating Liquid
ConvF	The sensitivity of the TSL / sensitivity in TSL/NORM x, y, z
N/A	not applicable or not measured

Calibration is preformed according to the Following Standards

- a) IEEE Std 1528-2003, "IEEE Recommended Practice for Determining the Peak Spatial-Averaged Specific Absorption Rate (SAR) in Human Head from Wireless Communication Devices: Measurement Techniques", December 2003
- b) IEC 62209-1, "Procedure to measure the Specific Absorption Rate (SAR) for hand-held devices used in close proximity to the ear (frequency range of 300MHz to 3GHz) ", February 2005
- c) Federal Communication Commission Office of Engineering & Technology (FCC OET), "Evaluating Compliance with FCC Guidelines for Human Exposure to Radiofrequency Electromagnetic Fields; Additional Information for Evaluating Compliance of Mobile and Portable Devices with FCC Limits for Human Exposure to Radiofrequency Emissions", Supplement C (Edition 01-01) to Bulletin 65

Additional Documentation:

- e) DASY System Handbook

Tel: +86-10-68009202 68009203 Fax: +86-10-68009205 68009195
Add: No.80 Bei Lishi Road, Xi Cheng District Beijing 100037, P.R.China

Page 4 of 8 Certificate No.SRTC2010-CAL003-003

The State Radio_monitoring_center Testing Center

Methods Applied and Interpretation of Parameters

- Measurement Conditions: Further details are available from the Validation Report at the end of the certificate. All figures stated in the certificate are valid at the frequency indicated.
- Antenna Parameters with TSL: The dipole is mounted with the spacer to position its feed point exactly below the center marking of the flat phantom section, with the arms oriented parallel to the body axis.
- SAR measured: SAR measured at the stated antenna input power
- SAR normalized: SAR as measured, normalized to an input power of 1 W at the antenna connector.
- SAR for nominal TSL parameters: The measured TSL parameters are used to calculate the nominal SAR result.

Measurement Conditions

DASY Version	DSAY 5	V5.0 Build 126
Extrapolation	Advanced Extrapolation	——
Phantom	ELI4	——
Distance Dipole Center-TSL	15mm	With spacer (See note)
Area Scan Resolution	dx,dy=15mm	——
Zoom Scan Resolution	dx,dy,dz=5mm	——
Frequency	900MHz	——

Note: As client can not provide a spacer for their dipole, we used a alternate method to define the distance from dipole center to TSL. Pictures in Annex 3 show the details.

The State Radio_monitoring_center Testing Center

Head TSL Parameters

The following parameters and calculation were applied

	Temperature	Permittivity	Conductivity
Nominal Head TSL parameters	22.0°C	41.5	0.97mho/m
Measured Head TSL parameters	(22±0.5)°C	41.2	0.95m±5%
Head TSL temperature during test	(21.6±0.6)°C	——	——

1. SAR-Head TSL

SAR -1g SAR averaged over 1cm ³ (1g) of Head TSL	Condition	——
SAR measured	250mW input power	2.70mW/g
SAR normalized	normalized to 1W	10.80mW/g
SAR for nominal Head TSL parameters	normalized to 1W	10.71 mW/g±15.20%(k=2)

SAR-10g SAR averaged over 10cm ³ (10g) of Head TSL	Condition	——
SAR measured	250mW input power	1.72mW/g
SAR normalized	normalized to 1W	6.88mW/g
SAR for nominal Head TSL parameters	normalized to 1W	6.80mW/g±14.38%(k=2)

The State Radio_monitoring_center Testing Center

2. Annex

Annex 1

Date/Time: 6/11/2010 8:30:47 AM

Test Laboratory: SRTC, Beijing, China

DUT: Dipole 900 MHz; Type: D900V2; Serial: D900V2 - SN:171

Communication System: CW; Frequency: 900 MHz; Duty Cycle: 1:1
Medium parameters used: $f = 900$ MHz; $\sigma = 0.949$ mho/m; $\epsilon_r = 41.2$; $\rho = 1000$ kg/m³

Phantom section: Flat Section

Measurement Standard: DASYS (IEEE/IEC)

DASY4 Configuration:

- Probe: ES3DV3 - SN3128; ConvF(5.52, 5.52, 5.52); Calibrated: 6/22/2009
- Sensor-Surface: 4mm (Mechanical Surface Detection)
- Electronics: DAE4 Sn720; Calibrated: 1/18/2010
- Phantom: ELI 4.0; Type: QDOVA001BA
- Measurement SW: DASYS, V5.0 Build 126; SEMCAD X Version 13.4 Build 125

Pin=250mW; d=15mm /Zoom Scan (7x7x7) (7x7x7)/Cube 0:

Measurement grid: dx=5mm, dy=5mm, dz=5mm

Reference Value = 56.3 V/m; Power Drift = -0.025 dB

Peak SAR (extrapolated) = 4.18 W/kg

SAR(1 g) = 2.7 mW/g; SAR(10 g) = 1.72 mW/g

Maximum value of SAR (measured) = 2.93 mW/g

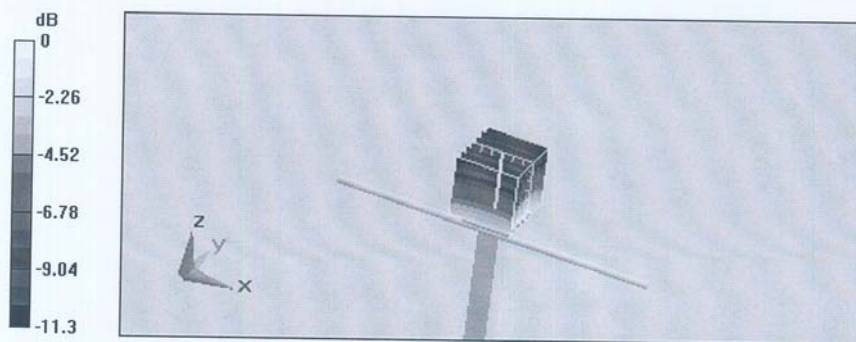

0 dB = 2.93mW/g

Tel: +86-10-68009202 68009203 Fax: +86-10-68009205 68009195
Add: No.80 Bei Lishi Road, Xi Cheng District Beijing 100037, P.R.China

Page 7 of 8 Certificate No.SRTC2010-CAL003-003

The State Radio_monitoring_center Testing Center

Annex 2

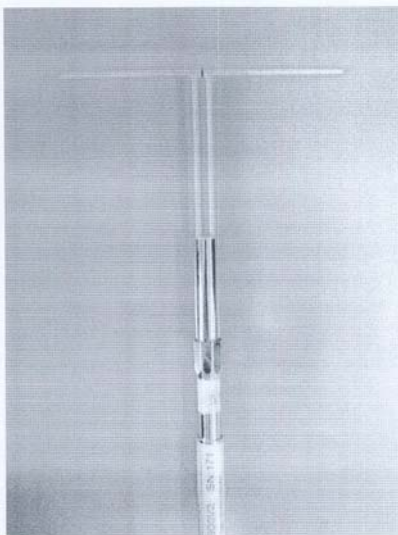

Calibrated by

张明远

Checked by

刘翔

Tel: +86-10-68009202 68009203 Fax: +86-10-68009205 68009195
Add: No.80 Bei Lishi Road, Xi Cheng District Beijing 100037, P.R .China

Page 8 of 8 Certificate No.SRTC2010-CAL003-003

**Calibration Laboratory of
Schmid & Partner
Engineering AG**
Zoughausstrasse 43, 8004 Zurich, Switzerland



S Schweizerischer Kalibrierdienst
C Service suisse d'étalonnage
S Servizio svizzero di taratura
S Swiss Calibration Service

Accredited by the Swiss Accreditation Service (SAS)
The Swiss Accreditation Service is one of the signatories to the EA
Multilateral Agreement for the recognition of calibration certificates

Accreditation No.: **SCS 108**

Glossary:

TSL tissue simulating liquid
ConvF sensitivity in TSL / NORM x,y,z
N/A not applicable or not measured

Calibration is Performed According to the Following Standards:

- a) IEEE Std 1528-2003, "IEEE Recommended Practice for Determining the Peak Spatial-Averaged Specific Absorption Rate (SAR) in the Human Head from Wireless Communications Devices: Measurement Techniques", December 2003
- b) IEC 62209-1, "Procedure to measure the Specific Absorption Rate (SAR) for hand-held devices used in close proximity to the ear (frequency range of 300 MHz to 3 GHz)", February 2005
- c) Federal Communications Commission Office of Engineering & Technology (FCC OET), "Evaluating Compliance with FCC Guidelines for Human Exposure to Radiofrequency Electromagnetic Fields; Additional Information for Evaluating Compliance of Mobile and Portable Devices with FCC Limits for Human Exposure to Radiofrequency Emissions", Supplement C (Edition 01-01) to Bulletin 65

Additional Documentation:

- d) DASY4/5 System Handbook

Methods Applied and Interpretation of Parameters:

- *Measurement Conditions:* Further details are available from the Validation Report at the end of the certificate. All figures stated in the certificate are valid at the frequency indicated.
- *Antenna Parameters with TSL:* The dipole is mounted with the spacer to position its feed point exactly below the center marking of the flat phantom section, with the arms oriented parallel to the body axis.
- *Feed Point Impedance and Return Loss:* These parameters are measured with the dipole positioned under the liquid filled phantom. The impedance stated is transformed from the measurement at the SMA connector to the feed point. The Return Loss ensures low reflected power. No uncertainty required.
- *Electrical Delay:* One-way delay between the SMA connector and the antenna feed point. No uncertainty required.
- *SAR measured:* SAR measured at the stated antenna input power.
- *SAR normalized:* SAR as measured, normalized to an input power of 1 W at the antenna connector.
- *SAR for nominal TSL parameters:* The measured TSL parameters are used to calculate the nominal SAR result..

Measurement Conditions

DASY system configuration, as far as not given on page 1.

DASY Version	DASY4	V4.7
Extrapolation	Advanced Extrapolation	
Phantom	Modular Flat Phantom V4.9	
Distance Dipole Center - TSL	15 mm	with Spacer
Zoom Scan Resolution	dx, dy, dz = 5 mm	
Frequency	835 MHz \pm 1 MHz	

Head TSL parameters

The following parameters and calculations were applied.

	Temperature	Permittivity	Conductivity
Nominal Head TSL parameters	22.0 °C	41.5	0.90 mho/m
Measured Head TSL parameters	(22.0 \pm 0.2) °C	40.4 \pm 6 %	0.88 mho/m \pm 6 %
Head TSL temperature during test	(22.0 \pm 0.2) °C	---	---

SAR result with Head TSL

SAR averaged over 1 cm ³ (1 g) of Head TSL	Condition	
SAR measured	250 mW input power	2.37 mW / g
SAR normalized	normalized to 1W	9.48 mW / g
SAR for nominal Head TSL parameters ¹	normalized to 1W	9.46 mW / g \pm 17.0 % (k=2)

SAR averaged over 10 cm ³ (10 g) of Head TSL	condition	
SAR measured	250 mW input power	1.56 mW / g
SAR normalized	normalized to 1W	6.24 mW / g
SAR for nominal Head TSL parameters ¹	normalized to 1W	6.21 mW / g \pm 16.5 % (k=2)

¹ Correction to nominal TSL parameters according to d), chapter "SAR Sensitivities"

Body TSL parameters

The following parameters and calculations were applied.

	Temperature	Permittivity	Conductivity
Nominal Body TSL parameters	22.0 °C	55.2	0.97 mho/m
Measured Body TSL parameters	(22.0 ± 0.2) °C	53.4 ± 6 %	0.99 mho/m ± 6 %
Body TSL temperature during test	(22.0 ± 0.2) °C	---	---

SAR result with Body TSL

SAR averaged over 1 cm ³ (1 g) of Body TSL	Condition	
SAR measured	250 mW input power	2.42 mW / g
SAR normalized	normalized to 1W	9.68 mW / g
SAR for nominal Body TSL parameters ²	normalized to 1W	9.36 mW / g ± 17.0 % (k=2)

SAR averaged over 10 cm ³ (10 g) of Body TSL	condition	
SAR measured	250 mW input power	1.60 mW / g
SAR normalized	normalized to 1W	6.40 mW / g
SAR for nominal Body TSL parameters ²	normalized to 1W	6.24 mW / g ± 16.5 % (k=2)

² Correction to nominal TSL parameters according to d), chapter "SAR Sensitivities"

Appendix

Antenna Parameters with Head TSL

Impedance, transformed to feed point	54.9 Ω - 2.6 j Ω
Return Loss	-25.5 dB

Antenna Parameters with Body TSL

Impedance, transformed to feed point	50.3 Ω - 4.5 j Ω
Return Loss	- 27.0 dB

General Antenna Parameters and Design

Electrical Delay (one direction)	1.390 ns
----------------------------------	----------

After long term use with 100W radiated power, only a slight warming of the dipole near the feedpoint can be measured.

The dipole is made of standard semirigid coaxial cable. The center conductor of the feeding line is directly connected to the second arm of the dipole. The antenna is therefore short-circuited for DC-signals.

No excessive force must be applied to the dipole arms, because they might bend or the soldered connections near the feedpoint may be damaged.

Additional EUT Data

Manufactured by	SPEAG
Manufactured on	July 04, 2005

DASY4 Validation Report for Head TSL

Date/Time: 16.06.2008 10:59:00

Test Laboratory: SPEAG, Zurich, Switzerland

DUT: Dipole 835 MHz; Type: D835V2; Serial: D835V2 - SN:4d023

Communication System: CW-835; Frequency: 835 MHz; Duty Cycle: 1:1

Medium: HSL 900 MHz;

Medium parameters used: $f = 835$ MHz; $\sigma = 0.88$ mho/m; $\epsilon_r = 40.4$; $\rho = 1000$ kg/m³

Phantom section: Flat Section

Measurement Standard: DASY4 (High Precision Assessment)

DASY4 Configuration:

- Probe: ES3DV2 - SN3025; ConvF(5.97, 5.97, 5.97); Calibrated: 28.04.2008
- Sensor-Surface: 3.4mm (Mechanical Surface Detection)
- Electronics: DAE4 Sn601; Calibrated: 14.03.2008
- Phantom: Flat Phantom 4.9L; Type: QD000P49AA; ;
- Measurement SW: DASY4, V4.7 Build 71; Postprocessing SW: SEMCAD, V1.8 Build 184

Pin=250mW; dip=15mm; dist=3.4mm/Zoom Scan (7x7x7)/Cube 0: Measurement grid: dx=5mm, dy=5mm, dz=5mm

Reference Value = 56.5 V/m; Power Drift = -0.056 dB

Peak SAR (extrapolated) = 3.48 W/kg

SAR(1 g) = 2.37 mW/g; SAR(10 g) = 1.56 mW/g

Maximum value of SAR (measured) = 2.68 mW/g

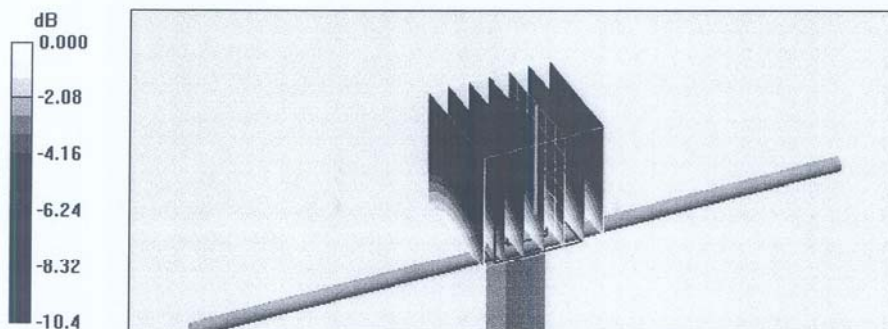

0 dB = 2.68mW/g

Impedance Measurement Plot for Head TSL

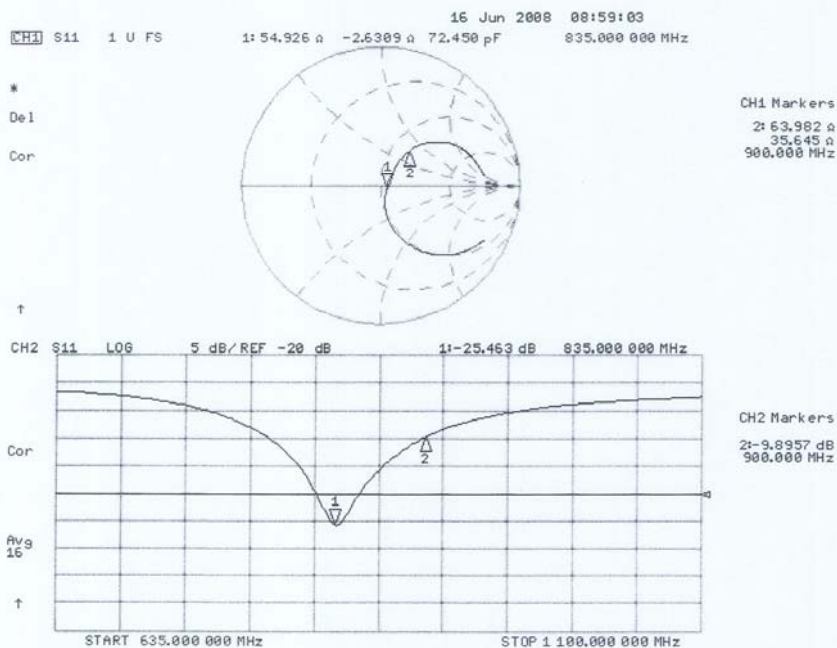

DASY4 Validation Report for Body TSL

Date/Time: 06.06.2008 12:44:11

Test Laboratory: SPEAG, Zurich, Switzerland

DUT: Dipole 835 MHz; Type: D835V2; Serial: D835V2 - SN:4d023

Communication System: CW; Frequency: 835 MHz; Duty Cycle: 1:1

Medium: MSL900;

Medium parameters used: $f = 835$ MHz; $\sigma = 0.99$ mho/m; $\epsilon_r = 53.4$; $\rho = 1000$ kg/m³

Phantom section: Flat Section

Measurement Standard: DASY4 (High Precision Assessment)

DASY4 Configuration:

- Probe: ES3DV2 - SN3025; ConvF(5.9, 5.9, 5.9); Calibrated: 28.04.2008
- Sensor-Surface: 3.4mm (Mechanical Surface Detection)
- Electronics: DAE4 Sn601; Calibrated: 14.03.2008
- Phantom: Flat Phantom 4.9L; Type: QD000P49AA; ;
- Measurement SW: DASY4, V4.7 Build 71; Postprocessing SW: SEMCAD, V1.8 Build 184

Pin = 250mW, d = 15mm/Zoom Scan (7x7x7)/Cube 0: Measurement grid: dx=5mm, dy=5mm, dz=5mm

Reference Value = 53.7 V/m; Power Drift = 0.008 dB

Peak SAR (extrapolated) = 3.49 W/kg

SAR(1 g) = 2.42 mW/g; SAR(10 g) = 1.6 mW/g

Maximum value of SAR (measured) = 2.73 mW/g

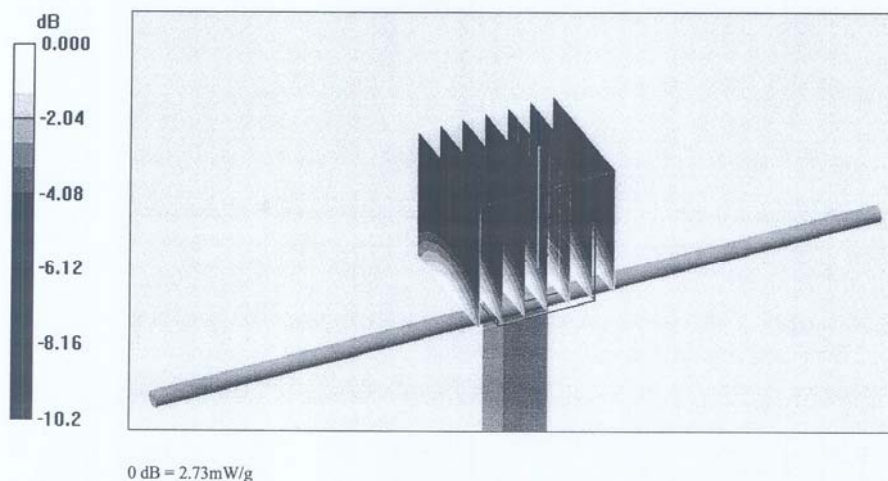

Impedance Measurement Plot for Body TSL

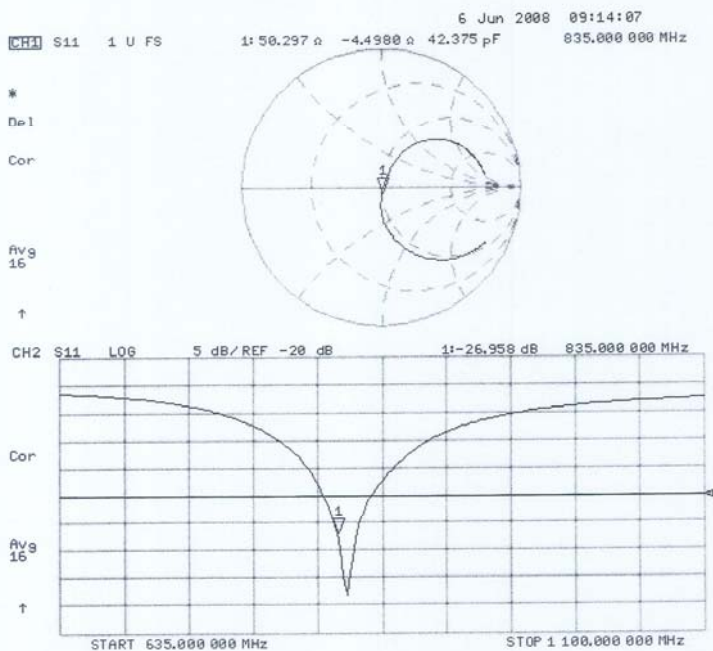

The State Radio_monitoring_center Testing Center

Calibration Certificate



Instrument Dipole

Type/Model D1800V2

Manufacturer Schmid & Partner Engineering AG

Serial No SN:2d084

Name of Client The State Radio_monitoring_center Testing Center

Address of Client No.98 Bei Lishi Road XiCheng District

Calibration Date 2010.6.11

All calibrations have been conducted in the closed laboratory facility: environment temperature (22±3) °C and humidity<70%

Approved by



Tel: +86-10-68009202 68009203 Fax: +86-10-68009205 68009195
Add: No.80 Bei Lishi Road, Xi Cheng District Beijing 100037, P.R .China

Page 1 of 8 Certificate No.SRTC2010-CAL003-004

The State Radio_monitoring_center Testing Center

Reference documents of the measurement(Code, Name)	
SRMC3003-V1.0.0 Working procedure for calibration of SAR Testing system	
Place and environmental condition of the measurement	
Temperature 21.6℃	Humidity 30.7%
Location SRTC Room226	

Primary Calibration Equipment used	Model/Type	ID#	Cal Date	Scheduled Calibration
Power meter	E4417A	SN: MY45101004	2009.8	2010.8
Power sensor	E9300B	SN: MY41496001	2009.8	2010.8
Power sensor	E9300B	SN: MY41496003	2009.8	2010.8
Reference DAE	DAE4	SN: 720	2010.1	2011.1
Reference probe	ES3DV3	SN: 3128	2009.6	2010.6
Secondary Calibration Equipment used	Model/Type	ID#	Cal Date	Scheduled Calibration
Signal generator	SML03	SN:103514	2009.8	2010.8
Network analyzer	8714ET	SN:US40372083	2009.8	2010.8

Tel: +86-10-68009202 68009203 Fax: +86-10-68009205 68009195
Add: No.80 Bei Lishi Road, Xi Cheng District Beijing 100037, P.R.China

Page 2 of 8 Certificate No.SRTC2010-CAL003-004

The State Radio_monitoring_center Testing Center

Note:

1. This calibration certificate documents the traceability to national standards, which realize the physical units of measurements (SI).
The measurements and the uncertainties with confidence probability are given on the following pages and are part of the certificate.
2. This calibration certificate is not permitted to be reproduced except in full without written the approval of the only laboratory
3. SRTC is responsible for the whole of certificate only with stamp of SRTC.
4. The calibration results would be valid only for the items calibration.
5. The certification is written by Chinese and English. Exact meaning should be explained only on Chinese version.

Tel: +86-10-68009202 68009203 Fax: +86-10-68009205 68009195
Add: No.80 Bei Lishi Road, Xi Cheng District Beijing 100037, P.R. China

Page 3 of 8 Certificate No.SRTC2010-CAL003-004

The State Radio_monitoring_center Testing Center

Glossary

TSL	Tissue Simulating Liquid
ConvF	The sensitivity of the TSL / sensitivity in TSL/NORM x, y, z
N/A	not applicable or not measured

Calibration is preformed according to the Following Standards

- a) IEEE Std 1528-2003, "IEEE Recommended Practice for Determining the Peak Spatial-Averaged Specific Absorption Rate (SAR) in Human Head from Wireless Communication Devices: Measurement Techniques", December 2003
- b) IEC 62209-1, "Procedure to measure the Specific Absorption Rate (SAR) for hand-held devices used in close proximity to the ear (frequency range of 300MHz to 3GHz)", February 2005
- c) Federal Communication Commission Office of Engineering & Technology (FCC OET), "Evaluating Compliance with FCC Guidelines for Human Exposure to Radiofrequency Electromagnetic Fields; Additional Information for Evaluating Compliance of Mobile and Portable Devices with FCC Limits for Human Exposure to Radiofrequency Emissions", Supplement C (Edition 01-01) to Bulletin 65

Additional Documentation:

- e) DASY System Handbook

Tel: +86-10-68009202 68009203 Fax: +86-10-68009205 68009195
Add: No.80 Bei Lishi Road, Xi Cheng District Beijing 100037, P.R.China

Page 4 of 8 Certificate No.SRTC2010-CAL003-004

The State Radio_monitoring_center Testing Center

Methods Applied and Interpretation of Parameters

- Measurement Conditions: Further details are available from the Validation Report at the end of the certificate. All figures stated in the certificate are valid at the frequency indicated.
- Antenna Parameters with TSL: The dipole is mounted with the spacer to position its feed point exactly below the center marking of the flat phantom section, with the arms oriented parallel to the body axis.
- SAR measured: SAR measured at the stated antenna input power
- SAR normalized: SAR as measured, normalized to an input power of 1 W at the antenna connector.
- SAR for nominal TSL parameters: The measured TSL parameters are used to calculate the nominal SAR result.

Measurement Conditions

DASY Version	DSAY 5	V5.0 Build 126
Extrapolation	Advanced Extrapolation	——
Phantom	ELI4	——
Distance Dipole Center-TSL	10mm	With spacer (See note)
Area Scan Resolution	dx,dy=10mm	——
Zoom Scan Resolution	dx,dy,dz=5mm	——
Frequency	1800MHz	——

Note: As client can not provide a spacer for their dipole, we used a alternate method to define the distance from dipole center to TSL. Pictures in Annex 3 show the details.

The State Radio_monitoring_center Testing Center

Head TSL Parameters

The following parameters and calculation were applied

	Temperature	Permittivity	Conductivity
Nominal Head TSL parameters	22.0°C	40.0	1.40mho/m
Measured Head TSL parameters	(22±0.5)°C	39.2	1.35m±5%
Head TSL temperature during test	(21.6±0.6)°C	——	——

1. SAR-Head TSL

SAR -1g SAR averaged over 1cm ³ (1g) of Head TSL	Condition	——
SAR measured	250mW input power	9.55mW/g
SAR normalized	normalized to 1W	38.20mW/g
SAR for nominal Head TSL parameters	normalized to 1W	37.62 mW/g±15.20%(k=2)

SAR-10g SAR averaged over 10cm ³ (10g) of Head TSL	Condition	——
SAR measured	250mW input power	5.09mW/g
SAR normalized	normalized to 1W	20.36mW/g
SAR for nominal Head TSL parameters	normalized to 1W	20.13mW/g±14.38%(k=2)

The State Radio_monitoring_center Testing Center

2. Annex

Annex 1

Date/Time: 6/11/2010 8:30:47 AM

Test Laboratory: SRTC, Beijing, China

DUT: Dipole 1800 MHz; Type: D1800V2; Serial: D1800V2 - SN: 2d084

Communication System: CW; Frequency: 1800 MHz; Duty Cycle: 1:1
Medium parameters used: $f = 1800$ MHz; $\sigma = 1.35$ mho/m; $\epsilon_r = 39.2$; $\rho = 1000$ kg/m³
Phantom section: Flat Section
Measurement Standard: DASYS (IEEE/IEC)

DASY4 Configuration:

- Probe: ES3DV3 - SN3128; ConvF(4.93, 4.93, 4.93); Calibrated: 6/22/2009
- Sensor-Surface: 4mm (Mechanical Surface Detection)
- Electronics: DAE4 Sn720; Calibrated: 1/18/2010
- Phantom: ELI 4.0; Type: QDOVA001BA
- Measurement SW: DASYS, V5.0 Build 126; SEMCAD X Version 13.4 Build 125

Pin=250mW;d=10mm/Zoom Scan (7x7x7) (7x7x7)/Cube 0:

Measurement grid: dx=5mm, dy=5mm, dz=5mm
Reference Value = 89 V/m; Power Drift = -0.119 dB
Peak SAR (extrapolated) = 17.2 W/kg
SAR(1 g) = 9.55 mW/g; SAR(10 g) = 5.09 mW/g
Maximum value of SAR (measured) = 10.7 mW/g

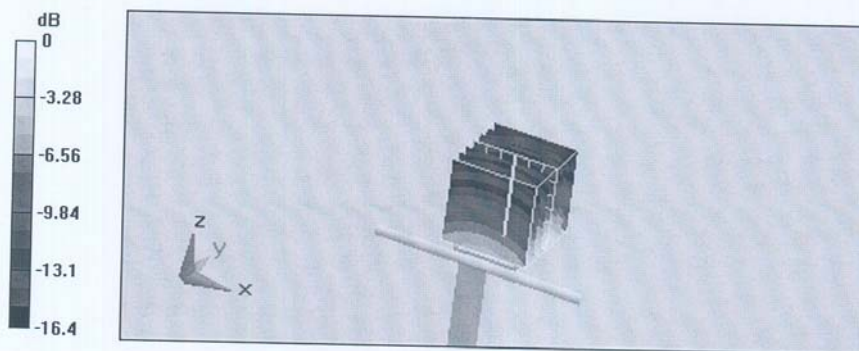

0 dB = 10.7mW/g

Tel: +86-10-68009202 68009203 Fax: +86-10-68009205 68009195
Add: No.80 Bei Lishi Road, Xi Cheng District Beijing 100037, P.R.China

Page 7 of 8 Certificate No.SRTC2010-CAL003-004

The State Radio_monitoring_center Testing Center

Annex 2

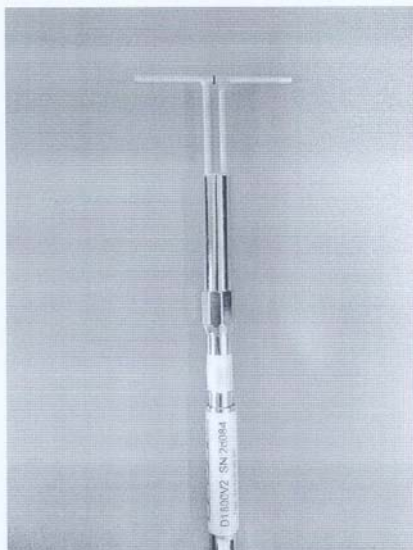

Calibrated by 张明远

Checked by 孙海

Tel: +86-10-68009202 68009203 Fax: +86-10-68009205 68009195
Add: No.80 Bei Lishi Road, Xi Cheng District Beijing 100037, P.R.China

Page 8 of 8 Certificate No.SRTC2010-CAL003-004