

# SAR TEST REPORT

<b>Equipment Under Test :</b>	GSM 850&PCS 1900MHz MOBILE PHONES
<b>Model No. :</b>	U81CA
<b>Market name:</b>	OT-S210A
<b>FCC ID:</b>	RAD077
<b>Applicant :</b>	TCT Mobile Suzhou Limited
<b>Address of Applicant :</b>	3/F,B2 Block, Digital Technology Yard, Gaoxin Nan Qi Road,Nan Shan District, Shenzhen, Guangdong, P.R. China
<b>Date of Receipt :</b>	2008.04.02
<b>Date of Test :</b>	2008.04.07 ~2008.05.28 2008.07.24~2008.07.25
<b>Date of Issue :</b>	2008.07.25

Standards:

**FCC OET Bulletin 65 supplement C,  
ANSI/IEEE C95.1, C95.3, IEEE 1528-2003**

In the configuration tested, the EUT complied with the standards specified above.

## Remarks:

This report details the results of the testing carried out on one sample, the results contained in this test report do not relate to other samples of the same product. The manufacturer should ensure that all products in series production are in conformity with the product sample detailed in this report.

This report may only be reproduced and distributed in full. If the product in this report is used in any configuration other than that detailed in the report, the manufacturer must ensure the new system complies with all relevant standards. Any mention of SGS-CSTC Shanghai GSM Lab or testing done by SGS-CSTC Shanghai GSM Lab must approve SGS Shanghai GSM Lab in connection with distribution or use of the product described in this report in writing.

Tested by :

*Zeng Zhang*

Date :

2008.07.25

Approved by :

*Zhang Yuan*

Date :

2008.07.25

# Contents

<b>1. General Information .....</b>	<b>5</b>
1.1 Test Laboratory.....	5
1.2 Details of Applicant .....	5
1.3 Description of EUT(s).....	5
1.4 Test Environment .....	6
1.5 Operation Configuration .....	6
1.6 The SAR Measurement System.....	6
1.7 SAR System Verification.....	8
1.8 Tissue Simulant Fluid for the Frequency Band 850MHZ and 1900MHz .....	9
1.9 Test Standards and Limits .....	10
<b>2. Summary of Results .....</b>	<b>11</b>
<b>3. Instruments List .....</b>	<b>13</b>
<b>4. Measurements .....</b>	<b>14</b>
4.1 GSM850-LeftHandSide-Cheek-Middle-BYD .....	14
GSM850-LeftHandSide-Cheek-Middle-BYD.....	14
4.2 GSM850-LeftHandSide-Tilt-Middle-BYD .....	15
GSM850-LeftHandSide-Tilt-Middle-BYD .....	15
4.3 GSM850-LeftHandSide-Cheek-Low-BYD .....	17
GSM850-LeftHandSide-Cheek-Low-BYD.....	17
4.4 GSM850-LeftHandSide-Cheek-High-BYD .....	19
GSM850-LeftHandSide-Cheek-High-BYD .....	19
4.5 GSM850-LeftHandSide-Cheek-Middle-Coslight .....	21
GSM850-LeftHandSide-Cheek-Middle-Coslight.....	21
4.6 GSM850-RightHandSide-Cheek-Middle-BYD .....	23
GSM850-RightHandSide-Cheek-Middle-BYD .....	23
4.7 GSM850-RightHandSide-Tilt-Middle-BYD.....	25
GSM850-RightHandSide-Tilt-Middle-BYD .....	25
4.8 GSM850-RightHandSide-Cheek-Low-BYD.....	27
GSM850-RightHandSide-Cheek-Low-BYD .....	27
4.9 GSM850-RightHandSide-Cheek-High-BYD.....	29
GSM850-RightHandSide-Cheek-High-BYD.....	29
4.10 GSM850-RightHandSide-Cheek-Middle-Coslight.....	31
GSM850-RightHandSide-Cheek-Middle-Coslight .....	31

<b>4.11 GSM850-Body-Worn -Low-BYD .....</b>	<b>33</b>
GSM850-Body-Worn-Low-2.0cm-BYD .....	33
<b>4.12 GSM850-Body-Worn -Middle-BYD.....</b>	<b>35</b>
GSM850-Body-Worn-Mid-2.0cm-BYD .....	35
<b>4.13 GSM850-Body-Worn -High-BYD .....</b>	<b>37</b>
GSM850-Body-Worn-High-2.0cm-BYD.....	37
<b>4.14 GSM850-Body-Worn -Low-Coslight .....</b>	<b>39</b>
GSM850-Body-Worn-Low-2.0cm-Coslight.....	39
<b>4.15 PCS1900-LeftHandSide-Cheek-Middle-BYD.....</b>	<b>41</b>
PCS1900-LeftHandSide-Cheek-Middle-BYD .....	41
<b>4.16 PCS1900-LeftHandSide-Tilt-Middle-BYD .....</b>	<b>43</b>
PCS1900-LeftHandSide-Tilt-Middle-BYD.....	43
<b>4.17 PCS1900-LeftHandSide-Cheek-Low-BYD .....</b>	<b>45</b>
PCS1900-LeftHandSide-Cheek-Low-BYD .....	45
<b>4.18 PCS1900-LeftHandSide-Cheek-High-BYD .....</b>	<b>47</b>
PCS1900-LeftHandSide-Cheek-High-BYD.....	47
<b>4.19 PCS1900-LeftHandSide-Cheek-Low-Coslight .....</b>	<b>49</b>
PCS1900-LeftHandSide-Cheek-Low-Coslight .....	49
<b>4.20 PCS1900-RightHandSide-Cheek-Middle-BYD .....</b>	<b>51</b>
PCS1900-RightHandSide-Cheek-Middle-BYD .....	51
<b>4.21 PCS1900-RightHandSide-Tilt-Middle-BYD.....</b>	<b>53</b>
PCS1900-RightHandSide-Tilt-Middle-BYD .....	53
<b>4.22 PCS1900-RightHandSide-Cheek-Low-BYD .....</b>	<b>55</b>
PCS1900-RightHandSide-Cheek-Low-BYD .....	55
<b>4.23 PCS1900-RightHandSide-Cheek-High-BYD.....</b>	<b>57</b>
PCS1900-RightHandSide-Cheek-High-BYD .....	57
<b>4.24 PCS1900-RightHandSide-Cheek-Low-Coslight.....</b>	<b>59</b>
PCS1900-RightHandSide-Cheek-Low-Coslight .....	59
<b>4.25 PCS1900-Body-Worn -Low-BYD.....</b>	<b>61</b>
GSM1900-Body-Worn--Low-2.0cm-BYD .....	61
<b>4.26 PCS1900-Body-Worn -Middle-BYD.....</b>	<b>63</b>
GSM1900-Body-Worn--Mid-2.0cm-BYD.....	63
<b>4.27 PCS1900-Body-Worn -High-BYD .....</b>	<b>65</b>
GSM1900-Body-Worn--High-2.0cm-BYD.....	65
<b>4.28 PCS1900-Body-Worn -Low-Coslight.....</b>	<b>67</b>

GSM1900-Body-Worn--Low-2.0cm-Coslight .....	67
<b>4.29 GSM850-Flat Phantom- Head-Middle-BYD .....</b>	<b>69</b>
GSM850-Head-Worn-Mid-BYD-0.5cm .....	69
<b>4.30 GSM850- Flat Phantom- Head -Low- BYD.....</b>	<b>71</b>
GSM850-Head-Worn-Low-BYD-0.5cm.....	71
<b>4.31 GSM850- Flat Phantom- Head -High- BYD.....</b>	<b>73</b>
GSM850-Head-Worn-High-BYD-0.5cm.....	73
<b>4.32 GSM850- Flat Phantom- Head -Mid-Coslight.....</b>	<b>74</b>
GSM850-Head-Worn-Mid-Cos-0.5cm .....	74
<b>4.33 PCS1900- Flat Phantom- Head -Middle- BYD .....</b>	<b>76</b>
PCS1900Head-Worn-Mid-BYD-0.5cm .....	76
<b>4.34 PCS1900- Flat Phantom- Head -Low- BYD .....</b>	<b>77</b>
PCS1900Head-Worn-Low-BYD-0.5cm .....	77
<b>4.35 PCS1900- Flat Phantom- Head -High- BYD.....</b>	<b>79</b>
PCS1900Head-Worn-High-BYD-0.5cm.....	79
<b>4.36 PCS1900- Flat Phantom- Head -Low-Coslight.....</b>	<b>80</b>
PCS1900Head-Worn-Low-Cos-0.5cm.....	80
<b>Appendix .....</b>	<b>82</b>
<b>1. Photographs of Test Setup.....</b>	<b>82</b>
<b>2. Photographs of the EUT .....</b>	<b>86</b>
<b>3. Photographs of the battery.....</b>	<b>87</b>
<b>4. Photograph of the charger and Headset .....</b>	<b>88</b>
<b>5. Probe Calibration certificate.....</b>	<b>89</b>
<b>6. DAE Calibration certification.....</b>	<b>98</b>
<b>7. Dipole Calibration certification .....</b>	<b>104</b>
<b>8. Uncertainty analysis .....</b>	<b>122</b>
<b>9. Phantom description .....</b>	<b>123</b>

# 1. General Information

## 1.1 Test Laboratory

GSM Lab

SGS-CSTC Standards Technical Services Co., Ltd Shanghai Branch  
9F, the 3<sup>rd</sup> Building, No.889, Yishan Rd, Xuhui District, Shanghai, China

Zip code: 200233

Telephone: +86 (0) 21 6495 1616

Fax: +86 (0) 21 6495 3679

Internet: <http://www.cn.sgs.com>

## 1.2 Details of Applicant

**Name:** TCT Mobile Suzhou Limited

**Address:** 3/F,B2 Block,Digital Technology Yard,  
Gaoxin Nan Qi Road,Nan Shan District,  
Shenzhen,Guangdong,P.R.China

## 1.3 Description of EUT(s)

<b>Brand name</b>	ALCATEL	
<b>Model No.</b>	U81CA	
<b>Market Name</b>	OT-S210A	
<b>Hardware Version</b>	PIO4	
<b>Software Version</b>	040	
<b>Serial No.</b>	IMEI: 01145300001024-7	
<b>Battery Type</b>	BYD	CAB2001010C1
	Coslight	CAB2001010C2
<b>Antenna Type</b>	Inner Antenna	
<b>Operation Mode</b>	GSM850/PCS1900	
<b>Modulation Mode</b>	GMSK	
<b>Frequency range</b>	GSM850	Tx: 824~849 MHz
		Rx: 869~894 MHz
	PCS1900	Tx: 1850~1910 MHz
		Rx: 1930~1990 MHz
<b>Nominated Maximum RF Conducted Power</b>	GSM850: 33.0dBm, PCS1900: 30.0dBm	

#### **1.4 Test Environment**

Ambient temperature: 22.0° C

Tissue Simulating Liquid: 22° C

Relative Humidity: 45%~55%

#### **1.5 Operation Configuration**

Configuration 1: GSM 850, LeftHandSide Cheek & 15° Tilt Position

Configuration 2: GSM 850, RightHandSide Cheek & 15° Tilt Position

Configuration 3: GSM 850, BodyWorn (2.0cm between EUT and phantom)

Configuration 4: PCS 1900, LeftHandSide Cheek & 15° Tilt Position

Configuration 5: PCS 1900, RightHandSide Cheek & 15° Tilt Position

Configuration 6: PCS 1900, BodyWorn (2.0cm between EUT and phantom)

Configuration 7: GSM 850&1900 Additional tests due to antenna located near mouth  
(0.5cm between EUT Top and Flat phantom)

#### **1.6 The SAR Measurement System**

A photograph of the SAR measurement System is given in Fig. a.

This SAR Measurement System uses a Computer-controlled 3-D stepper motor system (Speag Dasy 4 professional system). A Model ES3DV3 3088 E-field probe is used to determine the internal electric fields. The SAR can be obtained from the equation  $SAR = \sigma (|E_i|^2) / \rho$  where  $\sigma$  and  $\rho$  are the conductivity and mass density of the tissue-simulant.

The DASY4 system for performing compliance tests consists of the following items:

- ÿ A standard high precision 6-axis robot (Stabile RX family) with controller, teach pendant and software. An arm extension for accommodation the data acquisition electronics (DAE).
- ÿ A dosimetric probe, i.e., an isotropic E-field probe optimized and calibrated for usage in tissue simulating liquid. The probe is equipped with an optical surface detector system.

- A data acquisition electronics (DAE) which performs the signal amplification, signal multiplexing, AD-conversion, offset measurements, mechanical surface detection, collision detection, etc. The unit is battery powered with standard or rechargeable batteries. The signal is optically transmitted to the EOC.
- The Electro-optical converter (EOC) performs the conversion between optical and electrical of the signals for the digital communication to DAE and for the analog signal from the optical surface detection. The EOC is connected to the measurement server.

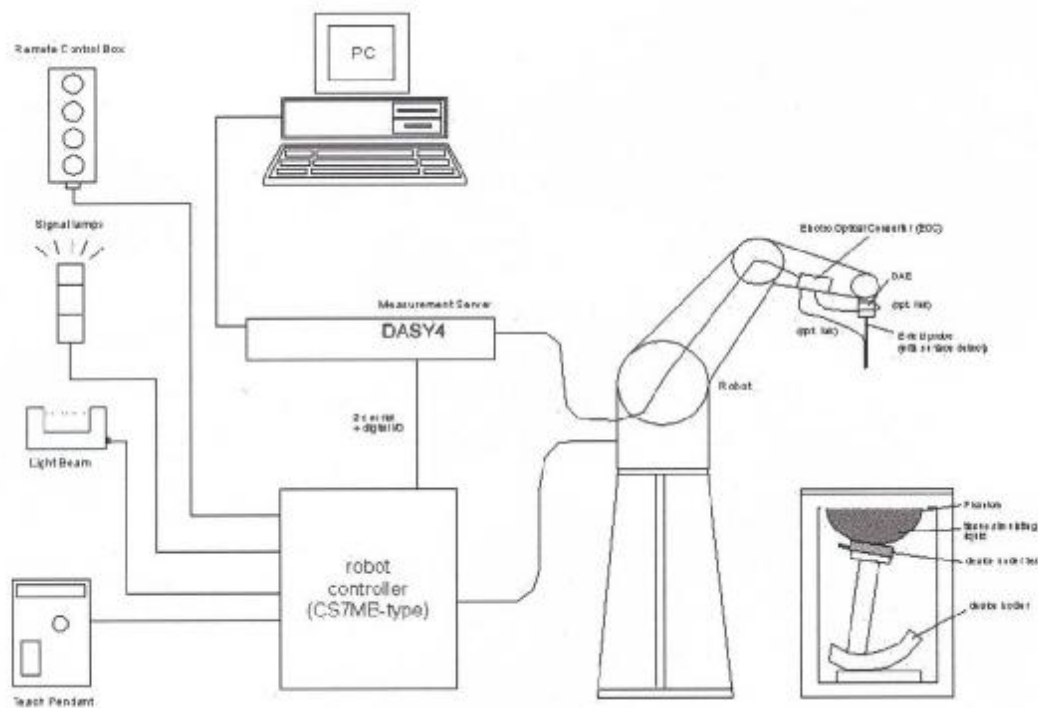

Fig. a SAR System Configuration

- The function of the measurement server is to perform the time critical tasks such as signal filtering, control of the robot operation and fast movement interrupts.
- A probe alignment unit which improves the (absolute) accuracy of the probe positioning.
- A computer operating Windows 2000.
- DASY4 software.
- Remote control with teach pendant and additional circuitry for robot safety such as warning lamps, etc.

- ÿ The SAM twin phantom enabling testing left-hand, right-hand and body-worn usage.
- ÿ The device holder for handheld mobile phones.
- ÿ Tissue simulating liquid mixed according to the given recipes.
- ÿ Validation dipole kits allowing to validating the proper functioning of the system.

### 1.7 SAR System Verification

The microwave circuit arrangement for system verification is sketched in Fig. b. The daily system accuracy verification occurs within the flat section of the SAM phantom. A SAR measurement was performed to see if the measured SAR was within +/- 10% from the target SAR values. These tests were done at 900&1900MHz. The tests were conducted on the same days as the measurement of the DUT. The obtained results from the system accuracy verification are displayed in the table 1 (SAR values are normalized to 1W forward power delivered to the dipole). During the tests, the ambient temperature of the laboratory was in the range 22°C, the relative humidity was in the range 60% and the liquid depth above the ear reference points was above 15 cm in all the cases. It is seen that the system is operating within its specification, as the results are within acceptable tolerance of the reference values.

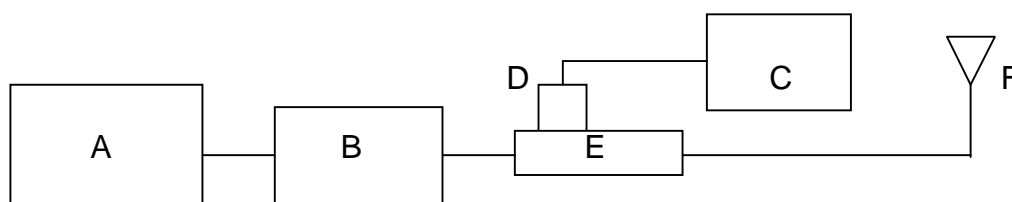

Fig. b the microwave circuit arrangement used for SAR system verification

- A. Agilent Model E4438C Signal Generator
- B. Mini-Circuit Model ZHL-42 Preamplifier



C. Agilent Model E4416A Power Meter

D. Agilent Model 8481H Power Sensor

E. HT CP6100 20N Dual directional coupler

F. Reference dipole antenna

Validation Kit	Frequency MHz	Target SAR 1g (250mW)	Target SAR 10g (250mW)	Measured SAR 1g	Measured SAR 10g	Measured Date
D900V2 SN184	900 Head	2.73	1.75	2.78	1.76	2008-04-07
				2.71	1.72	2008-04-16
				2.67	1.65	2008-07-25
D900V2 SN184	900 Body	2.90	1.87	2.86	1.83	2008-05-28
D1900V2 SN5d028	1900 Head	9.82	5.14	9.27	4.86	2008-04-10
				9.62	4.93	2008-07-24
D1900V2 SN5d028	1900 Body	9.34	4.97	9.47	4.92	2008-05-22

Table 1. Result System Validation

### 1.8 Tissue Simulant Fluid for the Frequency Band 850MHZ and 1900MHZ

The dielectric properties for this body-simulant fluid were measured by using the HP Model 85070D Dielectric Probe (rates frequency band 200 MHz to 20 GHz) in conjunction with Agilent E5071B Network Analyzer (300 KHz-8500 MHz). The Conductivity ( $\sigma$ ) and Permittivity ( $\rho$ ) are listed in Table 1. For the SAR measurement given in this report. The temperature variation of the Tissue Simulant Fluid was 22°C.

Frequency (MHz)	Tissue Type	Limit/Measured	Permittivity ( $\rho$ )	Conductivity ( $\sigma$ )	Simulated Tissue Temp (°C)
850	Head	<b>Recommended Limit</b>	<b>42.0±5%</b>	<b>0.99±5%</b>	<b>20-24</b>
		Measured, 2008-04-07	42.75	0.957	22.2
		Measured, 2008-04-16	42.31	0.973	22.7
		Measured, 2008-07-25	42.31	0.972	22.6
	Body	<b>Recommended Limit</b>	<b>55.0±5%</b>	<b>1.05±5%</b>	<b>20-24</b>
		Measured, 2008-05-28	55.12	1.034	21.9
1900	Head	<b>Recommended Limit</b>	<b>40.0±5%</b>	<b>1.38±5%</b>	<b>20-24</b>
		Measured, 2008-04-10	39.72	1.371	21.6

		Measured, 2008-07-24	39.46	1.403	22.2
	<b>Body</b>	<b>Recommended Limit</b>	<b>53.3±5%</b>	<b>1.52±5%</b>	<b>20-24</b>
		Measured, 2008-05-22	52.74	1.483	22.0

Table 2. Dielectric parameters for the Frequency Band 900&amp;1900MHZ

### 1.9 Test Standards and Limits

According to FCC 47 CFR §2.1093(d) the limits to be used for evaluation are based generally on criteria published by the American National Standards Institute (ANSI) for localized specific absorption rate (SAR) in Section 4.2 of "IEEE Standard for Safety Levels with Respect to Human Exposure to Radio Frequency Electromagnetic Fields, 3KHz to 300GHz," ANSI/IEEE C95.1-1992, Copyright 1992 by the Institute of Electrical & Electronics Engineers, Inc., New York, New York 10071.

<b>Human Exposure</b>	<b>Uncontrolled Environment General Population</b>
Spatial Peak SAR (Brain)	1.60 mW/g (averaged over a mass of 1g)

Table 3. RF Exposure Limits

## 2. Summary of Results

### GSM850 SAR

Mode	Test Configuration		SAR, Averaged over 1g (W/kg)			Temperature (°C)	Verdict
	Channel/Power(dBm)		Low/31.2	Middle/31.4	High/31.3		
GSM850	Left	Cheek(BYD)	1.14	1.23	1.2	22	Pass
		Tilt(BYD)	-	0.608	-	22	Pass
		Cheek(Coslight)	-	1.15	-	22	Pass
	Right	Cheek(BYD)	1.19	1.23	1.01	22	Pass
		Tilt(BYD)	-	0.625	-	22	Pass
		Cheek(Coslight)	-	1.27	-	22	Pass
	Body	BYD	0.818	0.677	0.613	22	Pass
		Coslight	0.852	-	-	22	Pass

### PCS1900 SAR

Mode	Test Configuration		SAR, Averaged over 1g (W/kg)			Temperature (°C)	Verdict
	Channel/Power(dBm)		Low/29.3	Middle/29.4	High/29.5		
PCS1900	Left	Cheek(BYD)	0.836	0.831	0.710	22	Pass
		Tilt(BYD)	-	0.193	-	22	Pass
		Cheek(Coslight)	0.919	-	-	22	Pass
	Right	Cheek(BYD)	1.23	1.14	0.944	22	Pass
		Tilt(BYD)	-	0.242	-	22	Pass
		Cheek(Coslight)	1.26	-	-	22	Pass
	Body	BYD	0.582	0.482	0.392	22	Pass
		Coslight	0.599	-	-	22	Pass

### Additional Tests to Verify Antenna Approaching Mouth

Mode	Test Configuration		SAR, Averaged over 1g (W/kg)			Temperature (°C)	Verdict
			Low/31.7	Middle/32	High/32		
GSM850	Channel/Power(dBm)		Low/31.7	Middle/32	High/32	22	Pass
	Flat Phantom GSM850	BYD	0.610	0.867	0.689	22	Pass
	Head HSL	Coslight	--	0.860	--	22	Pass
PCS1900	Channel/Power(dBm)		Low/29.9	Middle/29.7	High/29.6	22	Pass
	Flat Phantom GSM1900	BYD	0.448	0.324	0.307	22	Pass
	Head HSL	Coslight	0.417	--	--	22	Pass

### Maximum values

Frequency Band (MHz)	EUT position	Conducted Output Power (dBm)	1g Average (W/kg)	Power Drift(dB)	Amb. Temp (°C)	Verdict
850	LeftHand, Cheek, Middle Channel , BYD Battery	32.0	1.23	-0.154	22	PASS
	RightHand, Cheek, Middle Channel, Coslight Battery	32.0	1.27	-0.315	22	PASS
	BodyWorn, Low Channel, Coslight Battery	31.7	0.852	-0.097	22	PASS
1900	LeftHand, Cheek, Low Channel, Coslight Battery	29.9	0.919	0.015	22	PASS
	RightHand, Cheek, Low Channel, Coslight Battery	29.9	1.26	0.040	22	PASS
	BodyWorn, Middle Channel, Coslight Battery	29.7	0.599	-0.053	22	PASS

Note:

- In GSM850 band, the low, middle and high channels are CH128/824.2MHz, CH189/836.4MHz and CH251/848.8MHz separately.
- In PCS1900 band, the low, middle and high channels are CH512/1805.2MHz, CH661/1880.0MHz and CH810/1909.8MHz separately.
- For the Bodyworn measurements the sample was only placed with the antenna toward the phantom since this position delivers the highest SAR values. And the distance from the sample to the phantom is 2.0 cm.
- For all the tests, the maximum absolute value of the power drift which is under the GSM850-RightHandSide-Cheek-Middle-Coslight configuration is 0.315dB.
- Additional tests are performed to verify and eliminate the effect due to antenna approaching mouth. The evidence shows that the effect is restricted since the DUT Physical size is small (97\*43\*12 Unit: mm).

### 3. Instruments List

Instrument	Model	Serial number	NO.	Date of last Calibration
Desktop PC	COMPAQ EVO	N/A	GSM-SAR-025	N/A
Dasy 4 software	V 4.7 build 44	N/A	GSM-SAR-001	N/A
Probe	ES3DV3	3088	GSM-SAR-034	2008.1.18
DAE	DAE3	569	GSM-SAR-023	2007.11.19
900MHz system validation dipole	D900V2	184	GSM-SAR-017	2007.12.21
1900MHz system validation dipole	D1900V2	5d028	GSM-SAR-020	2007.12.21
Phantom	SAM 12	TP-1283	GSM-SAR-005	N/A
Robot	RX90L	F03/5V32A1/A01	GSM-SAR-006	N/A
Dielectric probe kit	85070D	US01440168	GSM-SAR-016	2007.12.18
Agilent network analyzer	E5071B	MY42100549	GSM-SAR-007	2007.12.18
Agilent signal generator	E4438	14438CATO-19719	GSM-SAR-008	2007.12.18
Mini-Circuits preamplifier	ZHL-42	D041905	GSM-SAR-033	2007.12.18
Agilent power meter	E4416A	GB41292095	GSM-SAR-010	2007.12.18
Agilent power sensor	8481H	MY41091234	GSM-SAR-011	2007.12.18
HT CP6100 20N Coupling	6100	SCP301480120	GSM-SAR-012	2007.12.18
R&S Universal radio communication tester	CMU200	103633	GSM-AUD-002	2007.12.18

## 4. Measurements

### 4.1 GSM850-LeftHandSide-Cheek-Middle-BYD

Date/Time: 2008-4-16 22:39:04

Test Laboratory: SGS-GSM

GSM850-LeftHandSide-Cheek-Middle-BYD

DUT: KJ006AA01; Type: Head; Serial: 01145300001024-7

Communication System: GSM850-GSM Mode; Frequency: 836.4 MHz; Duty Cycle: 1:8.3

Medium: HSL850-Head Medium parameters used:  $f = 836.4$  MHz;  $\sigma = 0.905$  mho/m;  $\epsilon_r = 42.8$ ;  $\rho = 1000$  kg/m<sup>3</sup>

Phantom section: Left Section

DASY4 Configuration:

- Probe: ES3DV3 - SN3088; ConvF(6.15, 6.15, 6.15); Calibrated: 2008-1-18
- Sensor-Surface: 4mm (Mechanical Surface Detection)
- Electronics: DAE3 Sn569; Calibrated: 2007-11-19
- Phantom: SAM 12; Type: SAM V4.0; Serial: TP-1283
- Measurement SW: DASY4, V4.7 Build 44; Postprocessing SW: SEMCAD, V1.8 Build 171

Cheek position - Mid BYD/Area Scan (61x91x1): Measurement grid: dx=15mm, dy=15mm

Maximum value of SAR (interpolated) = 1.35 mW/g

Cheek position - Mid BYD/Zoom Scan (7x7x7) (7x7x7)/Cube 0: Measurement grid: dx=5mm, dy=5mm, dz=5mm

Reference Value = 17.5 V/m; Power Drift = -0.154 dB

Peak SAR (extrapolated) = 1.61 W/kg

SAR(1 g) = 1.23 mW/g; SAR(10 g) = 0.858 mW/g

Maximum value of SAR (measured) = 1.32 mW/g

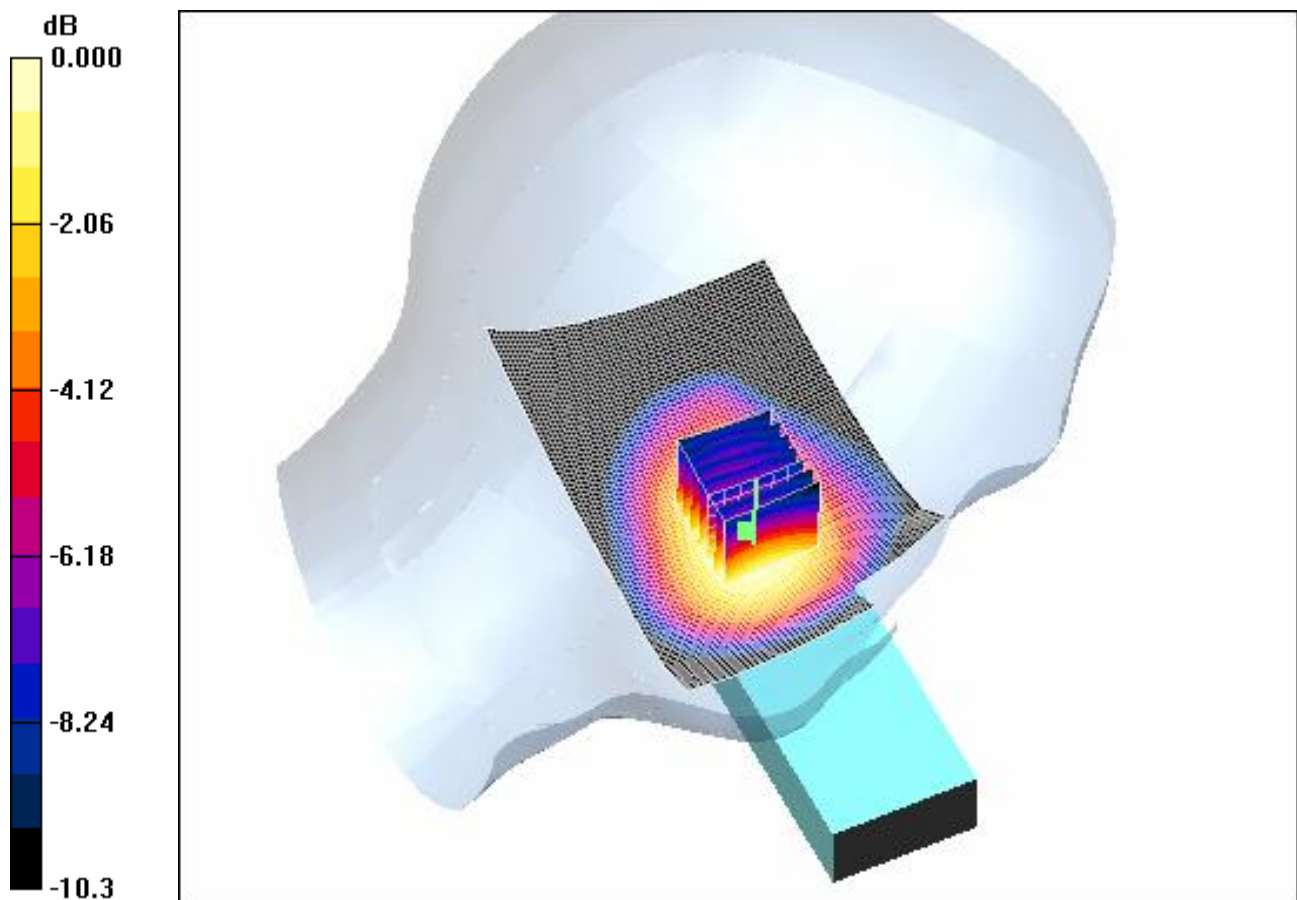

0 dB = 1.32mW/g

#### 4.2 GSM850-LeftHandSide-Tilt-Middle-BYD

Date/Time: 2008-4-17 8:48:26

Test Laboratory: SGS-GSM

GSM850-LeftHandSide-Tilt-Middle-BYD

DUT: KJ006AA01; Type: Head; Serial: 01145300001024-7

Communication System: GSM850-GSM Mode; Frequency: 836.4 MHz; Duty Cycle: 1:8.3

Medium: HSL850-Head Medium parameters used:  $f = 836.4$  MHz;  $\sigma = 0.905$  mho/m;  $\epsilon_r = 42.8$ ;  $\rho = 1000$  kg/m<sup>3</sup>

Phantom section: Left Section

**DASY4 Configuration:**

- Probe: ES3DV3 - SN3088; ConvF(6.15, 6.15, 6.15); Calibrated: 2008-1-18
- Sensor-Surface: 4mm (Mechanical Surface Detection)
- Electronics: DAE3 Sn569; Calibrated: 2007-11-19
- Phantom: SAM 12; Type: SAM V4.0; Serial: TP-1283
- Measurement SW: DASY4, V4.7 Build 44; Postprocessing SW: SEMCAD, V1.8 Build 171

**Tilt position - Mid BYD/Area Scan (61x91x1): Measurement grid: dx=15mm, dy=15mm**

**Maximum value of SAR (interpolated) = 0.650 mW/g**

**Tilt position - Mid BYD/Zoom Scan (7x7x7) (7x7x7)/Cube 0: Measurement grid: dx=5mm, dy=5mm, dz=5mm**

**Reference Value = 18.9 V/m; Power Drift = -0.004 dB**

**Peak SAR (extrapolated) = 0.834 W/kg**

**SAR(1 g) = 0.608 mW/g; SAR(10 g) = 0.424 mW/g**

**Maximum value of SAR (measured) = 0.649 mW/g**



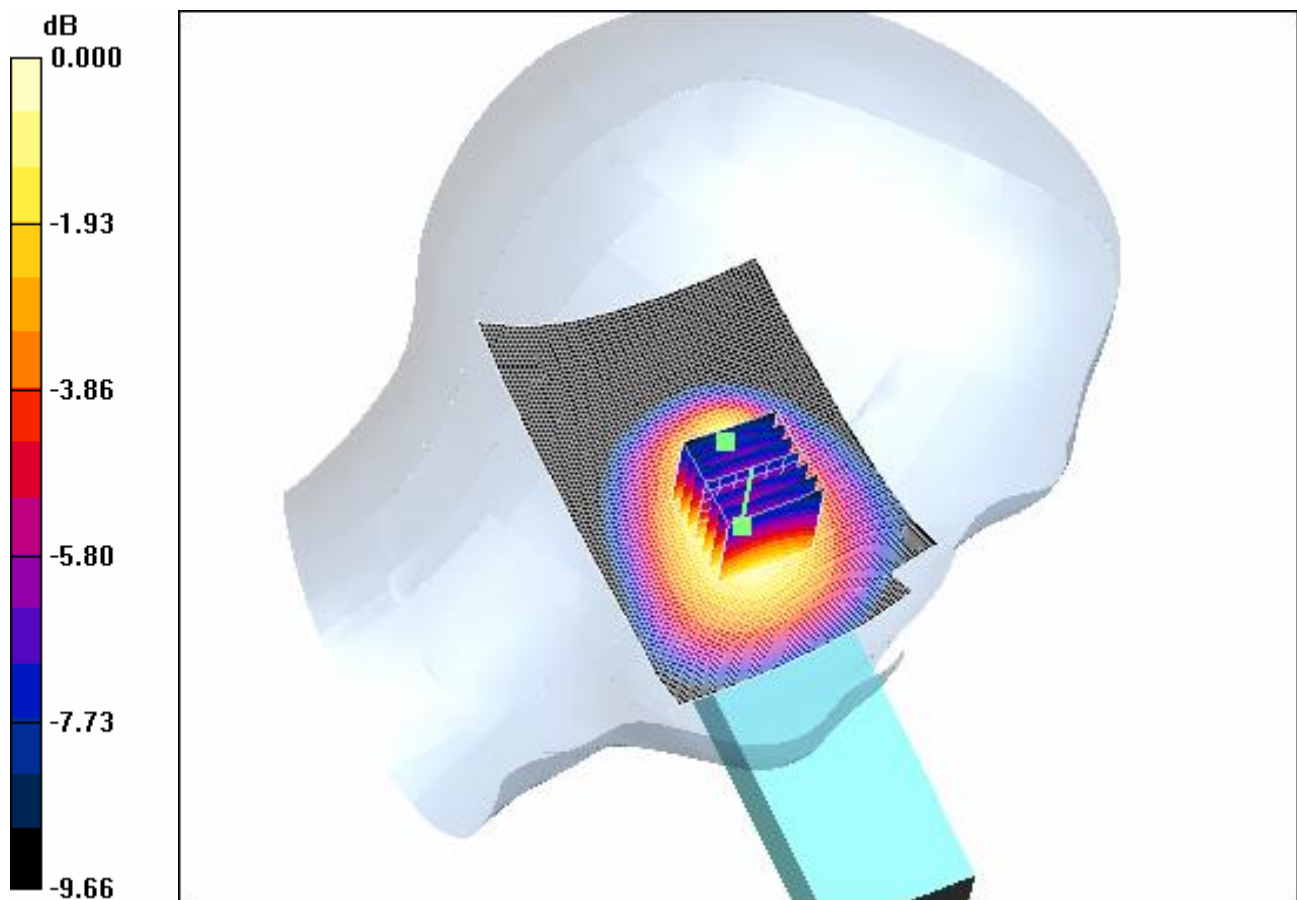

0 dB = 0.649mW/g

#### 4.3 GSM850-LeftHandSide-Cheek-Low-BYD

Date/Time: 2008-4-17 8:21:03

Test Laboratory: SGS-GSM

GSM850-LeftHandSide-Cheek-Low-BYD

DUT: KJ006AA01; Type: Head; Serial: 01145300001024-7

Communication System: GSM850-GSM Mode; Frequency: 824.2 MHz; Duty Cycle: 1:8.3

Medium: HSL850-Head Medium parameters used:  $f = 824.2$  MHz;  $\sigma = 0.892$  mho/m;  $\epsilon_r = 42.9$ ;  $\rho = 1000$  kg/m<sup>3</sup>

Phantom section: Left Section

**DASY4 Configuration:**

- Probe: ES3DV3 - SN3088; ConvF(6.15, 6.15, 6.15); Calibrated: 2008-1-18
- Sensor-Surface: 4mm (Mechanical Surface Detection)
- Electronics: DAE3 Sn569; Calibrated: 2007-11-19
- Phantom: SAM 12; Type: SAM V4.0; Serial: TP-1283
- Measurement SW: DASY4, V4.7 Build 44; Postprocessing SW: SEMCAD, V1.8 Build 171

**Cheek position - Low BYD/Area Scan (61x91x1):** Measurement grid: dx=15mm, dy=15mm

Maximum value of SAR (interpolated) = 1.26 mW/g

**Cheek position - Low BYD/Zoom Scan (7x7x7)/Cube 0:** Measurement grid: dx=5mm, dy=5mm, dz=5mm

Reference Value = 14.3 V/m; Power Drift = -0.063 dB

Peak SAR (extrapolated) = 1.52 W/kg

SAR(1 g) = 1.14 mW/g; SAR(10 g) = 0.793 mW/g

Maximum value of SAR (measured) = 1.23 mW/g

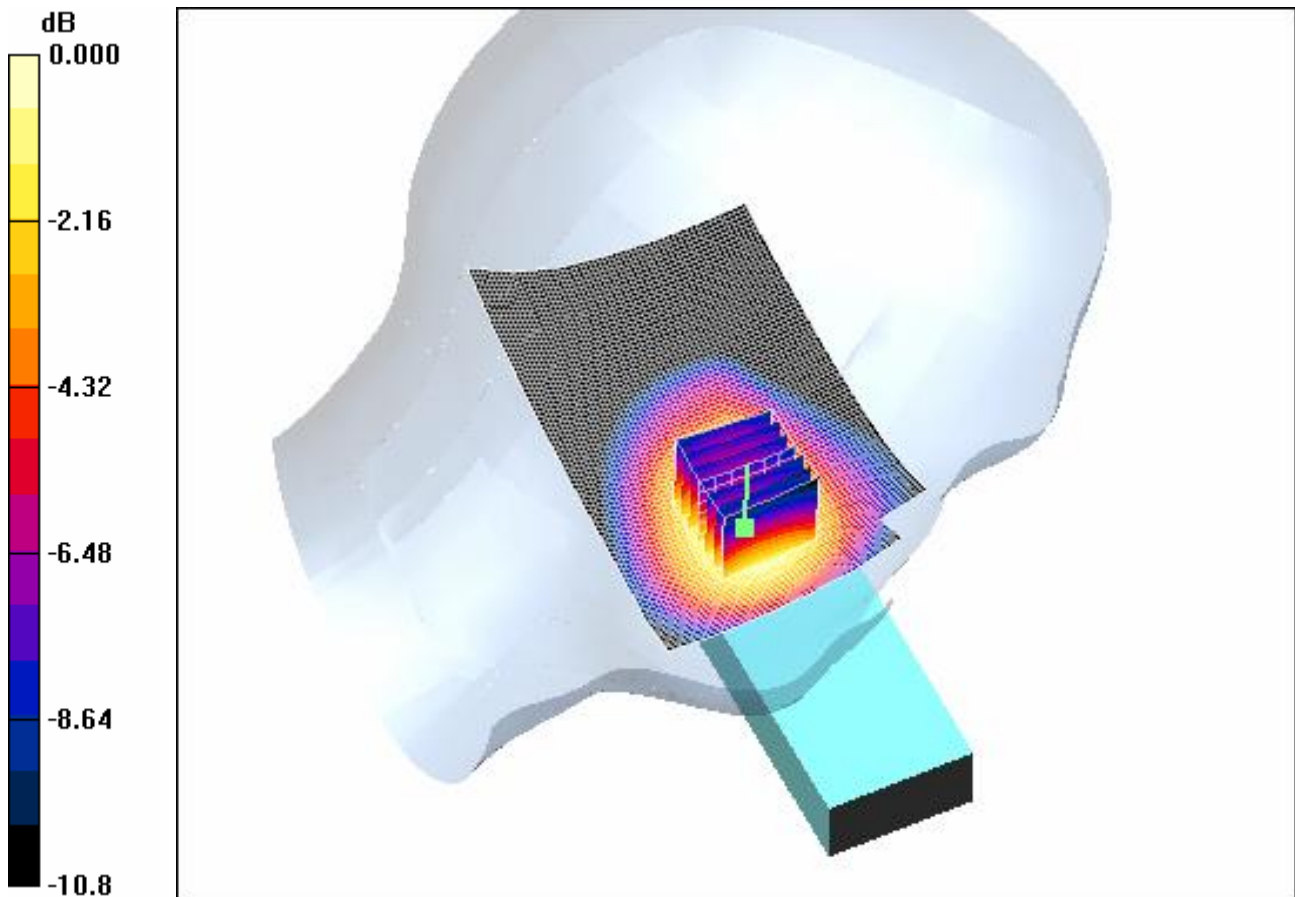

0 dB = 1.23mW/g

#### 4.4 GSM850-LeftHandSide-Cheek-High-BYD

Date/Time: 2008-4-16 23:04:32

Test Laboratory: SGS-GSM

GSM850-LeftHandSide-Cheek-High-BYD

DUT: KJ006AA01; Type: Head; Serial: 01145300001024-7

Communication System: GSM850-GSM Mode; Frequency: 848.8 MHz; Duty Cycle: 1:8.3

Medium: HSL850-Head Medium parameters used:  $f = 848.8$  MHz;  $\sigma = 0.918$  mho/m;  $\epsilon_r = 42.6$ ;  $\rho = 1000$  kg/m<sup>3</sup>

Phantom section: Left Section

**DASY4 Configuration:**

- Probe: ES3DV3 - SN3088; ConvF(6.15, 6.15, 6.15); Calibrated: 2008-1-18
- Sensor-Surface: 4mm (Mechanical Surface Detection)
- Electronics: DAE3 Sn569; Calibrated: 2007-11-19
- Phantom: SAM 12; Type: SAM V4.0; Serial: TP-1283
- Measurement SW: DASY4, V4.7 Build 44; Postprocessing SW: SEMCAD, V1.8 Build 171

**Cheek position - High BYD/Area Scan (61x91x1):** Measurement grid: dx=15mm, dy=15mm

Maximum value of SAR (interpolated) = 1.32 mW/g

**Cheek position - High BYD/Zoom Scan (7x7x7) (7x7x7)/Cube 0:** Measurement grid: dx=5mm, dy=5mm, dz=5mm

Reference Value = 14.4 V/m; Power Drift = -0.153 dB

Peak SAR (extrapolated) = 1.58 W/kg

SAR(1 g) = 1.2 mW/g; SAR(10 g) = 0.837 mW/g

Maximum value of SAR (measured) = 1.28 mW/g

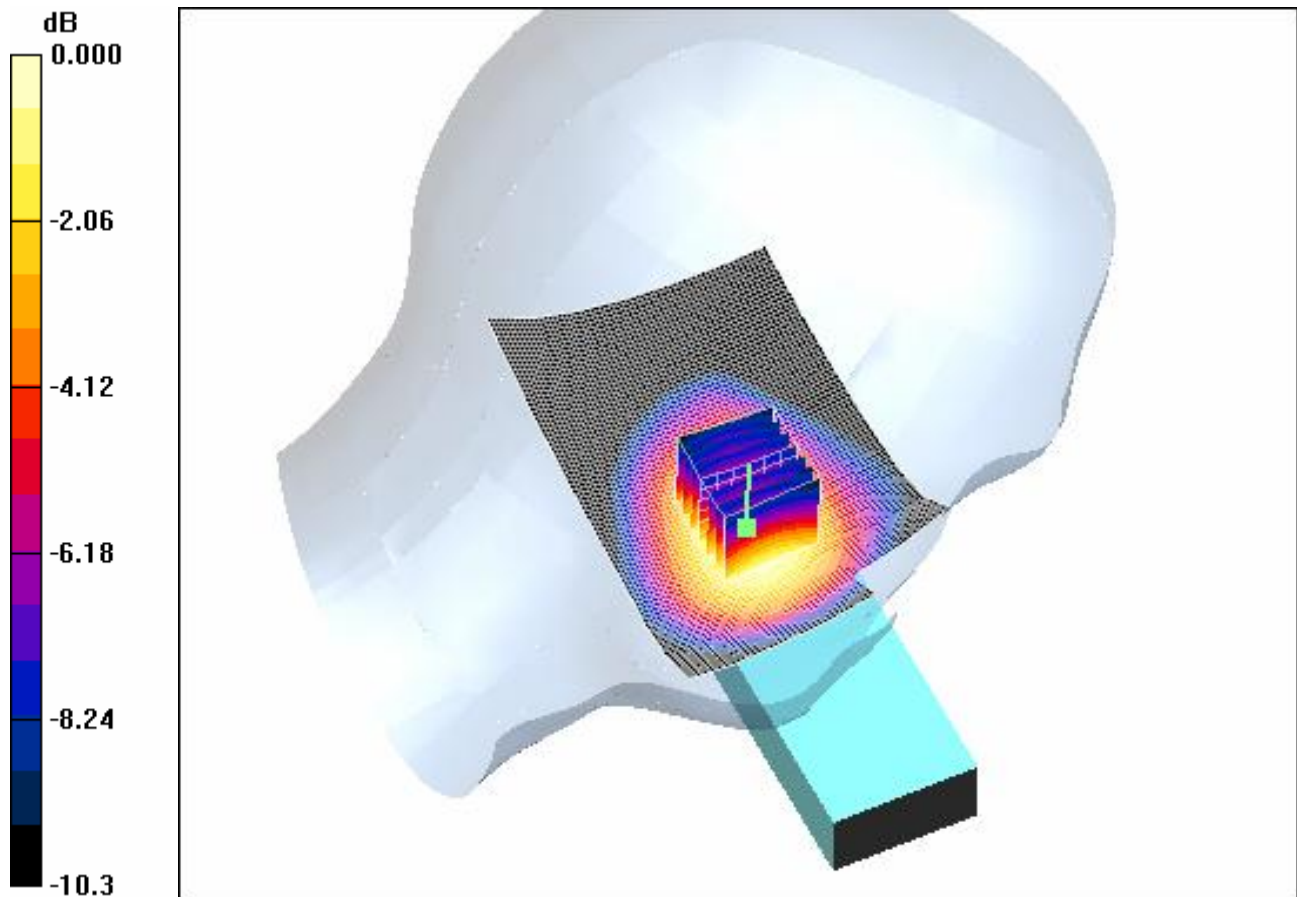

0 dB = 1.28mW/g

#### **4.5 GSM850-LeftHandSide-Cheek-Middle-Coslight**

Date/Time: 2008-4-17 9:25:51

Test Laboratory: SGS-GSM

GSM850-LeftHandSide-Cheek-Middle-Coslight

DUT: KJ006AA01; Type: Head; Serial: 01145300001024-7

Communication System: GSM850-GSM Mode; Frequency: 836.4 MHz; Duty Cycle: 1:8.3

Medium: HSL850-Head Medium parameters used:  $f = 836.4$  MHz;  $\sigma = 0.905$  mho/m;  $\epsilon_r = 42.8$ ;  $\rho = 1000$  kg/m<sup>3</sup>

Phantom section: Left Section

**DASY4 Configuration:**

- Probe: ES3DV3 - SN3088; ConvF(6.15, 6.15, 6.15); Calibrated: 2008-1-18
- Sensor-Surface: 4mm (Mechanical Surface Detection)
- Electronics: DAE3 Sn569; Calibrated: 2007-11-19
- Phantom: SAM 12; Type: SAM V4.0; Serial: TP-1283
- Measurement SW: DASY4, V4.7 Build 44; Postprocessing SW: SEMCAD, V1.8 Build 171

**Cheek position - Mid Coslight/Area Scan (61x91x1): Measurement grid: dx=15mm, dy=15mm**  
Maximum value of SAR (interpolated) = 1.26 mW/g

**Cheek position - Mid Coslight/Zoom Scan (7x7x7) (7x7x7)/Cube 0: Measurement grid: dx=5mm, dy=5mm, dz=5mm**

Reference Value = 15.1 V/m; Power Drift = -0.250 dB

Peak SAR (extrapolated) = 1.53 W/kg

SAR(1 g) = 1.15 mW/g; SAR(10 g) = 0.798 mW/g

Maximum value of SAR (measured) = 1.25 mW/g

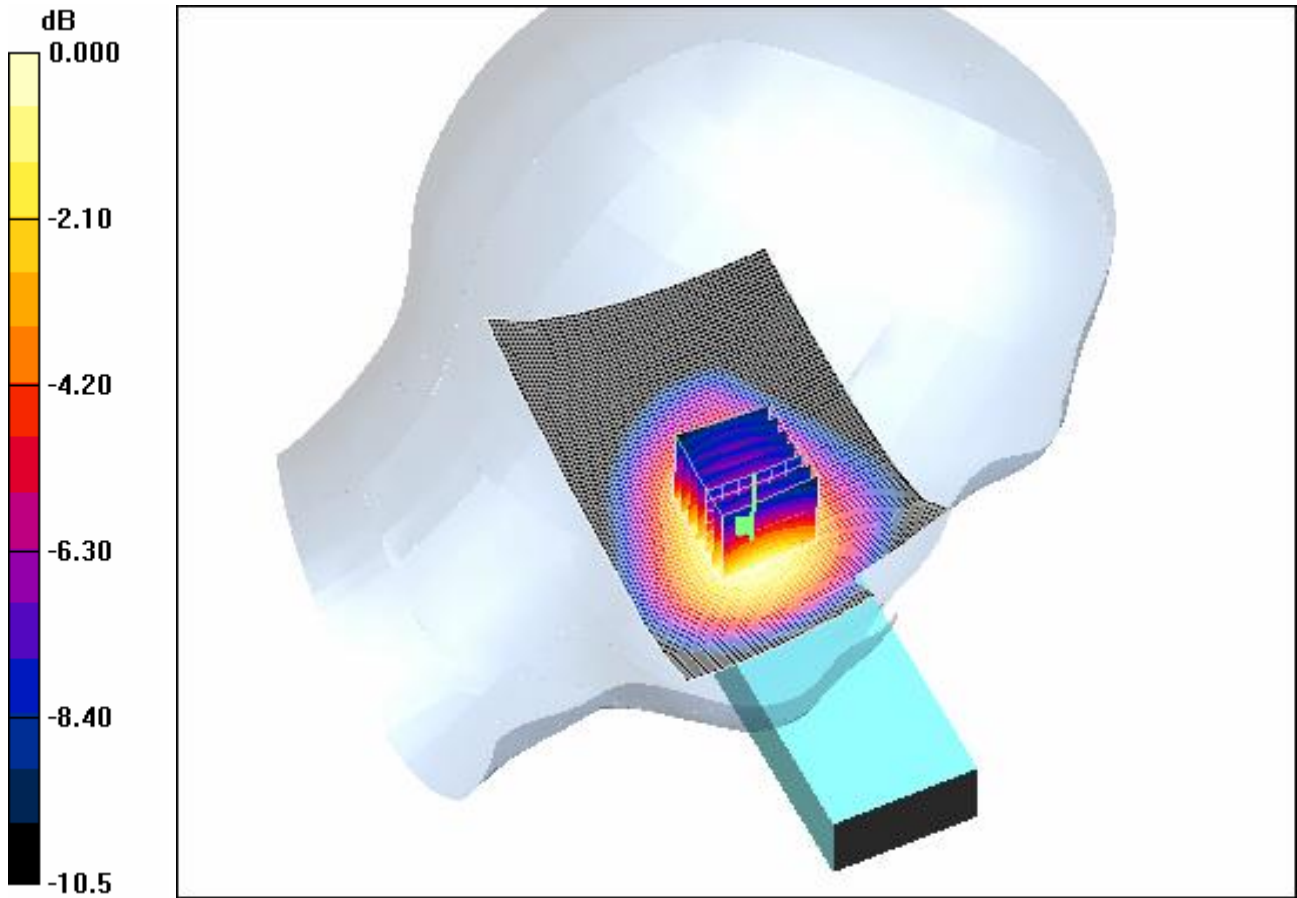

0 dB = 1.25mW/g

#### 4.6 GSM850-RightHandSide-Cheek-Middle-BYD

Date/Time: 2008-4-7 10:32:55

Test Laboratory: SGS-GSM

GSM850-RightHandSide-Cheek-Middle-BYD

DUT: KJ006AA01; Type: Head; Serial: 01145300001024-7

Communication System: GSM850-GSM Mode; Frequency: 836.4 MHz; Duty Cycle: 1:8.3

Medium: HSL900-Head Medium parameters used:  $f = 836.4$  MHz;  $\sigma = 0.905$  mho/m;  $\epsilon_r = 42.8$ ;  $\rho = 1000$  kg/m<sup>3</sup>

Phantom section: Right Section

**DASY4 Configuration:**

- Probe: ES3DV3 - SN3088; ConvF(6.15, 6.15, 6.15); Calibrated: 2008-1-18
- Sensor-Surface: 4mm (Mechanical Surface Detection)
- Electronics: DAE3 Sn569; Calibrated: 2007-11-19
- Phantom: SAM 12; Type: SAM V4.0; Serial: TP-1283
- Measurement SW: DASY4, V4.7 Build 44; Postprocessing SW: SEMCAD, V1.8 Build 171

**Cheek position - Middle BYD/Area Scan (61x91x1): Measurement grid: dx=15mm, dy=15mm**

**Maximum value of SAR (interpolated) = 1.32 mW/g**

**Cheek position - Middle BYD/Zoom Scan (7x7x7)/Cube 0: Measurement grid: dx=5mm, dy=5mm, dz=5mm**

**Reference Value = 17.1 V/m; Power Drift = -0.079 dB**

**Peak SAR (extrapolated) = 1.63 W/kg**

**SAR(1 g) = 1.23 mW/g; SAR(10 g) = 0.851 mW/g**

**Maximum value of SAR (measured) = 1.33 mW/g**



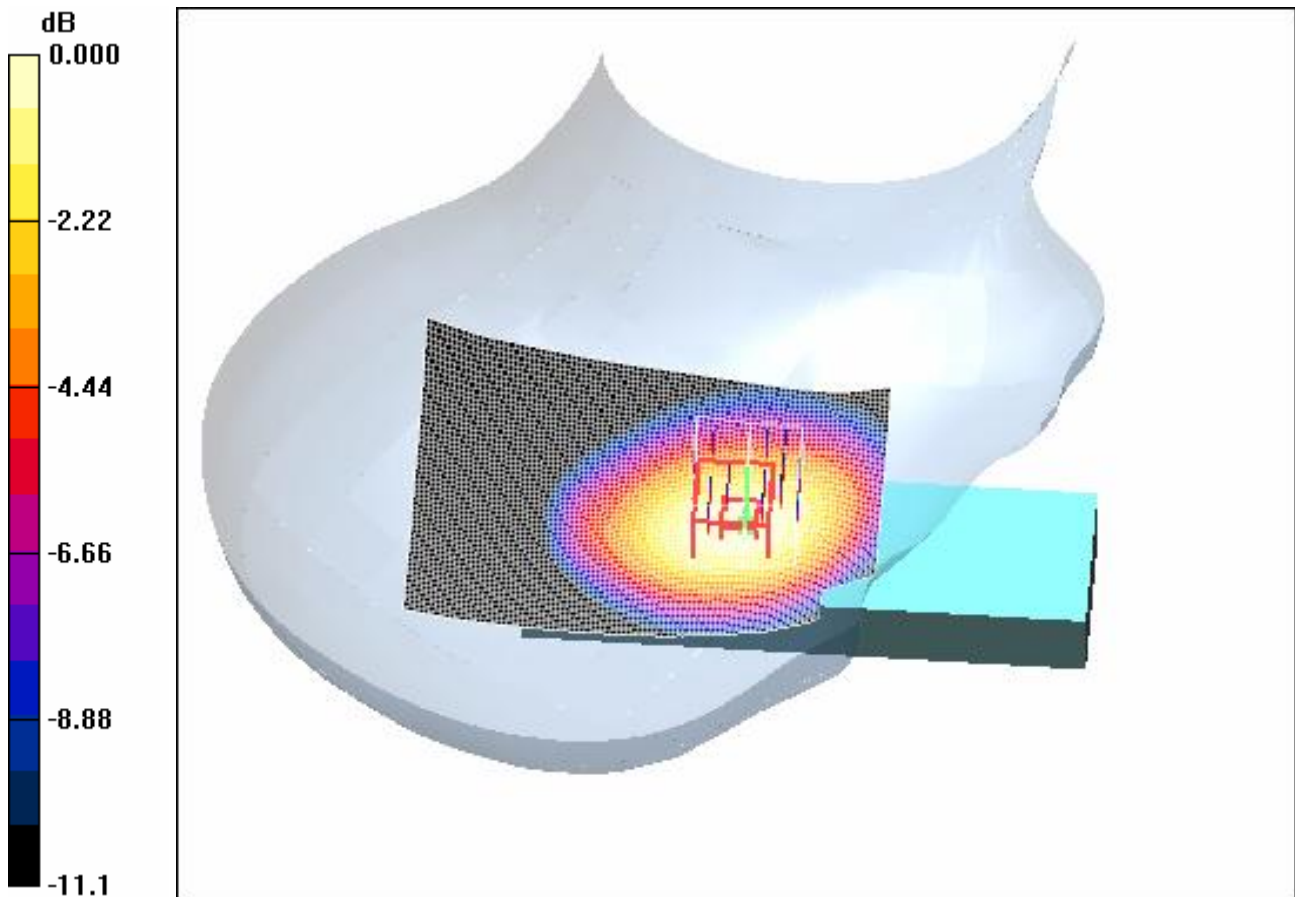

0 dB = 1.33mW/g

#### 4.7 GSM850-RightHandSide-Tilt-Middle-BYD

Date/Time: 2008-4-7 11:07:16

Test Laboratory: SGS-GSM

GSM850-RightHandSide-Tilt-Middle-BYD

DUT: KJ006AA01; Type: Head; Serial: 01145300001024-7

Communication System: GSM850-GSM Mode; Frequency: 836.4 MHz; Duty Cycle: 1:8.3

Medium: HSL900-Head Medium parameters used:  $f = 836.4$  MHz;  $\sigma = 0.905$  mho/m;  $\epsilon_r = 42.8$ ;  $\rho = 1000$  kg/m<sup>3</sup>

Phantom section: Right Section

**DASY4 Configuration:**

- Probe: ES3DV3 - SN3088; ConvF(6.15, 6.15, 6.15); Calibrated: 2008-1-18
- Sensor-Surface: 4mm (Mechanical Surface Detection)
- Electronics: DAE3 Sn569; Calibrated: 2007-11-19
- Phantom: SAM 12; Type: SAM V4.0; Serial: TP-1283
- Measurement SW: DASY4, V4.7 Build 44; Postprocessing SW: SEMCAD, V1.8 Build 171

**Tilt position - Middle BYD/Area Scan (61x91x1): Measurement grid: dx=15mm, dy=15mm**

**Maximum value of SAR (interpolated) = 0.671 mW/g**

**Tilt position - Middle BYD/Zoom Scan (7x7x7)/Cube 0: Measurement grid: dx=5mm, dy=5mm, dz=5mm**

**Reference Value = 21.0 V/m; Power Drift = 0.066 dB**

**Peak SAR (extrapolated) = 0.836 W/kg**

**SAR(1 g) = 0.625 mW/g; SAR(10 g) = 0.438 mW/g**

**Maximum value of SAR (measured) = 0.668 mW/g**

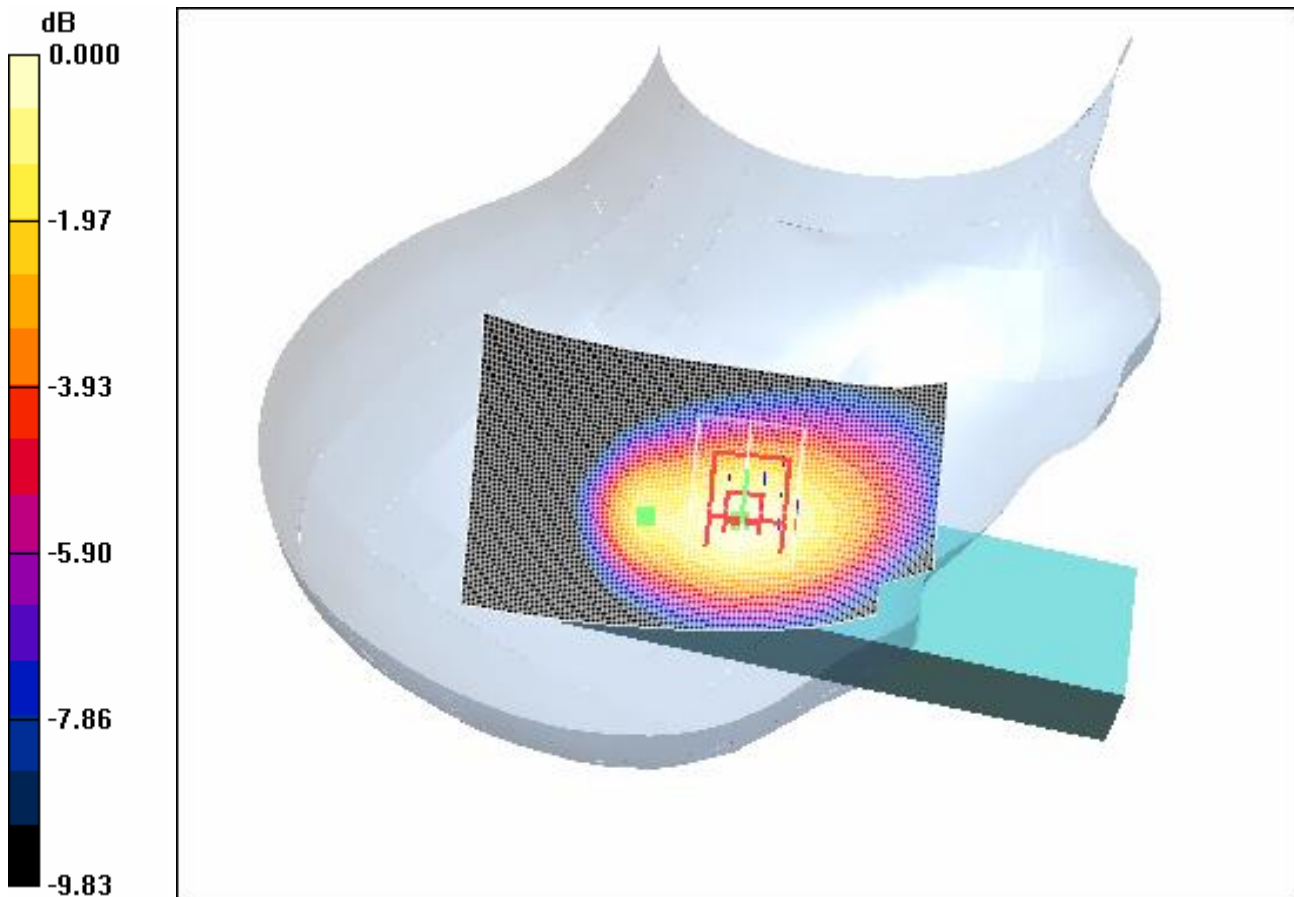

0 dB = 0.668mW/g

#### 4.8 GSM850-RightHandSide-Cheek-Low-BYD

Date/Time: 2008-4-7 9:12:55

Test Laboratory: SGS-GSM

GSM850-RightHandSide-Cheek-Low-BYD

DUT: KJ006AA01; Type: Head; Serial: 01145300001024-7

Communication System: GSM850-GSM Mode; Frequency: 824.2 MHz; Duty Cycle: 1:8.3

Medium: HSL900-Head Medium parameters used:  $f = 824.2$  MHz;  $\sigma = 0.892$  mho/m;  $\epsilon_r = 42.9$ ;  $\rho = 1000$  kg/m<sup>3</sup>

Phantom section: Right Section

**DASY4 Configuration:**

- Probe: ES3DV3 - SN3088; ConvF(6.15, 6.15, 6.15); Calibrated: 2008-1-18
- Sensor-Surface: 4mm (Mechanical Surface Detection)
- Electronics: DAE3 Sn569; Calibrated: 2007-11-19
- Phantom: SAM 12; Type: SAM V4.0; Serial: TP-1283
- Measurement SW: DASY4, V4.7 Build 44; Postprocessing SW: SEMCAD, V1.8 Build 171

**Cheek position - Low BYD/Area Scan (61x91x1):** Measurement grid: dx=15mm, dy=15mm

Maximum value of SAR (interpolated) = 1.29 mW/g

**Cheek position - Low BYD/Zoom Scan (7x7x7) (7x7x7)/Cube 0:** Measurement grid: dx=5mm, dy=5mm, dz=5mm

Reference Value = 14.7 V/m; Power Drift = -0.191 dB

Peak SAR (extrapolated) = 1.59 W/kg

SAR(1 g) = 1.19 mW/g; SAR(10 g) = 0.814 mW/g

Maximum value of SAR (measured) = 1.27 mW/g

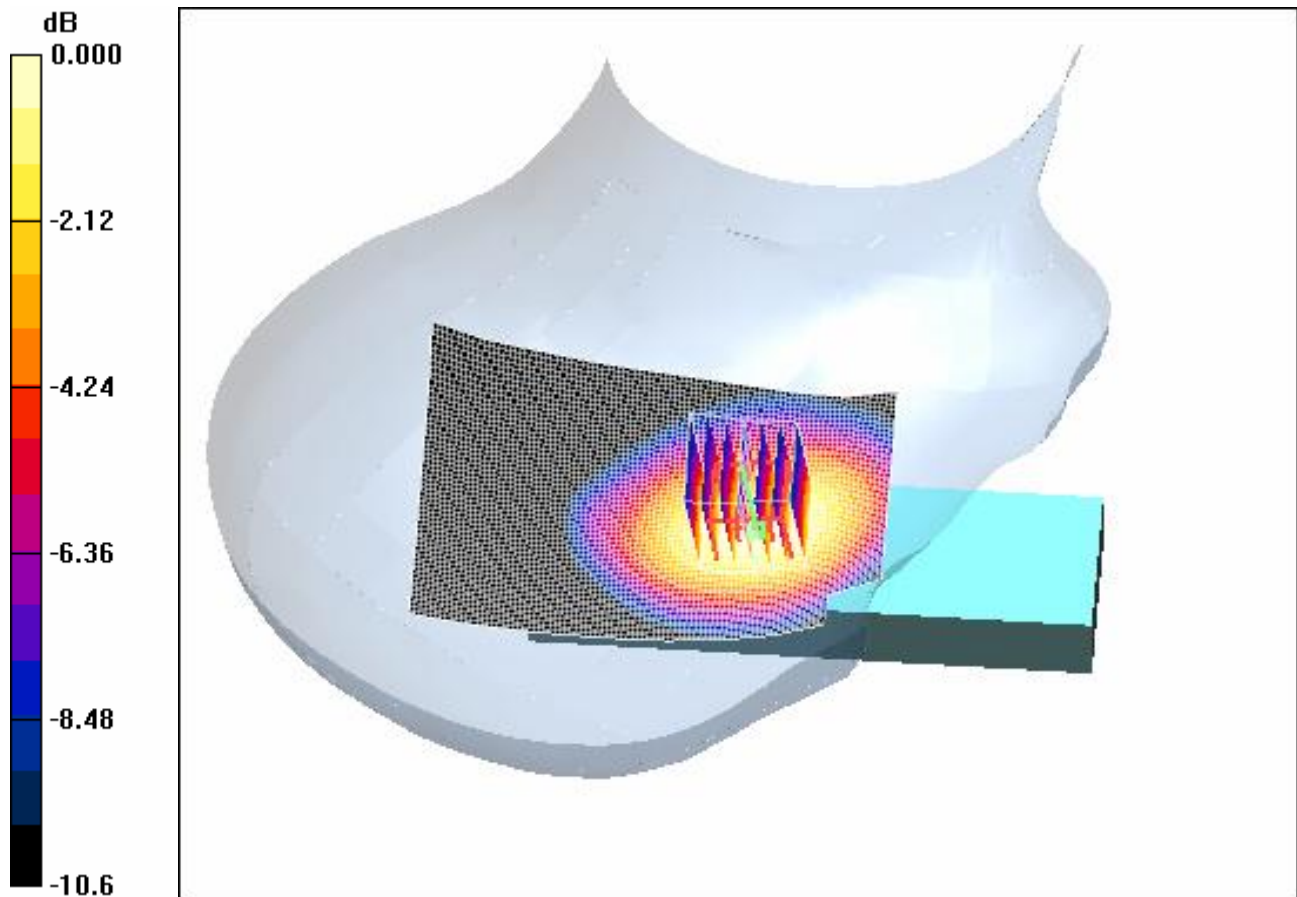

0 dB = 1.27mW/g

#### **4.9 GSM850-RightHandSide-Cheek-High-BYD**

Date/Time: 2008-4-7 9:39:12

Test Laboratory: SGS-GSM

GSM850-RightHandSide-Cheek-High-BYD

DUT: KJ006AA01; Type: Head; Serial: 01145300001024-7

Communication System: GSM850-GSM Mode; Frequency: 848.8 MHz; Duty Cycle: 1:8.3

Medium: HSL900-Head Medium parameters used:  $f = 848.8$  MHz;  $\sigma = 0.918$  mho/m;  $\epsilon_r = 42.6$ ;  $\rho = 1000$  kg/m<sup>3</sup>

Phantom section: Right Section

**DASY4 Configuration:**

- Probe: ES3DV3 - SN3088; ConvF(6.15, 6.15, 6.15); Calibrated: 2008-1-18
- Sensor-Surface: 4mm (Mechanical Surface Detection)
- Electronics: DAE3 Sn569; Calibrated: 2007-11-19
- Phantom: SAM 12; Type: SAM V4.0; Serial: TP-1283
- Measurement SW: DASY4, V4.7 Build 44; Postprocessing SW: SEMCAD, V1.8 Build 171

**Cheek position - High BYD/Area Scan (61x91x1):** Measurement grid: dx=15mm, dy=15mm

Maximum value of SAR (interpolated) = 1.09 mW/g

**Cheek position - High BYD/Zoom Scan (7x7x7) (7x7x7)/Cube 0:** Measurement grid: dx=5mm, dy=5mm, dz=5mm

Reference Value = 13.2 V/m; Power Drift = -0.080 dB

Peak SAR (extrapolated) = 1.35 W/kg

SAR(1 g) = 1.01 mW/g; SAR(10 g) = 0.690 mW/g

Maximum value of SAR (measured) = 1.07 mW/g

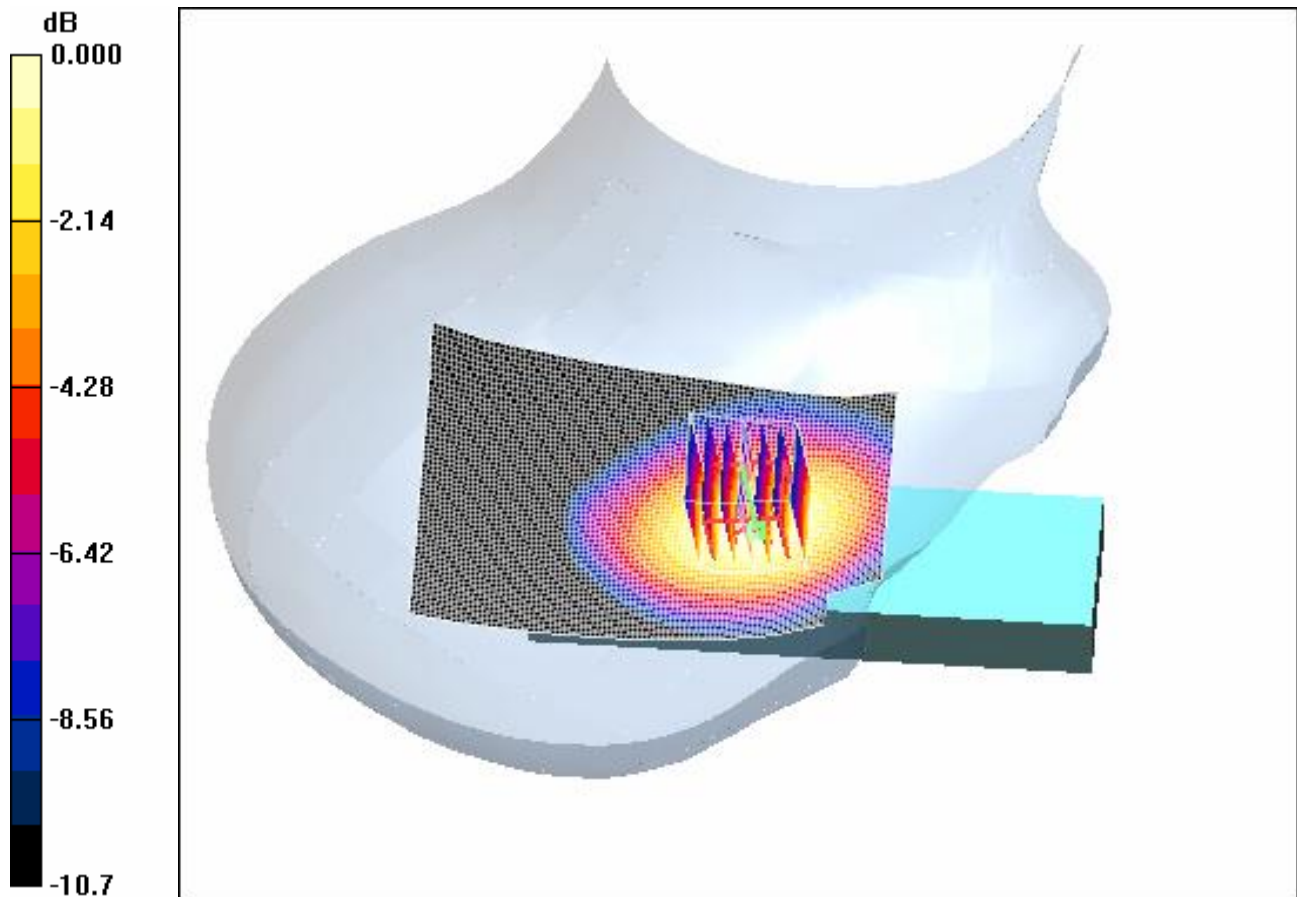

0 dB = 1.07mW/g

#### 4.10 GSM850-RightHandSide-Cheek-Middle-Coslight

Date/Time: 2008-4-7 8:45:33

Test Laboratory: SGS-GSM

GSM850-RightHandSide-Cheek-Middle-Coslight

DUT: KJ006AA01; Type: Head; Serial: 01145300001024-7

Communication System: GSM850-GSM Mode; Frequency: 836.4 MHz; Duty Cycle: 1:8.3

Medium: HSL900-Head Medium parameters used:  $f = 836.4$  MHz;  $\sigma = 0.905$  mho/m;  $\epsilon_r = 42.8$ ;  $\rho = 1000$  kg/m<sup>3</sup>

Phantom section: Right Section

**DASY4 Configuration:**

- Probe: ES3DV3 - SN3088; ConvF(6.15, 6.15, 6.15); Calibrated: 2008-1-18
- Sensor-Surface: 4mm (Mechanical Surface Detection)
- Electronics: DAE3 Sn569; Calibrated: 2007-11-19
- Phantom: SAM 12; Type: SAM V4.0; Serial: TP-1283
- Measurement SW: DASY4, V4.7 Build 44; Postprocessing SW: SEMCAD, V1.8 Build 171

**Cheek position - Middle Coslight/Area Scan (61x91x1):** Measurement grid: dx=15mm, dy=15mm  
Maximum value of SAR (interpolated) = 1.38 mW/g

**Cheek position - Middle Coslight/Zoom Scan (7x7x7)/Cube 0:** Measurement grid: dx=5mm,  
dy=5mm, dz=5mm

Reference Value = 17.7 V/m; Power Drift = -0.315 dB

Peak SAR (extrapolated) = 1.70 W/kg

SAR(1 g) = 1.27 mW/g; SAR(10 g) = 0.871 mW/g

Maximum value of SAR (measured) = 1.36 mW/g



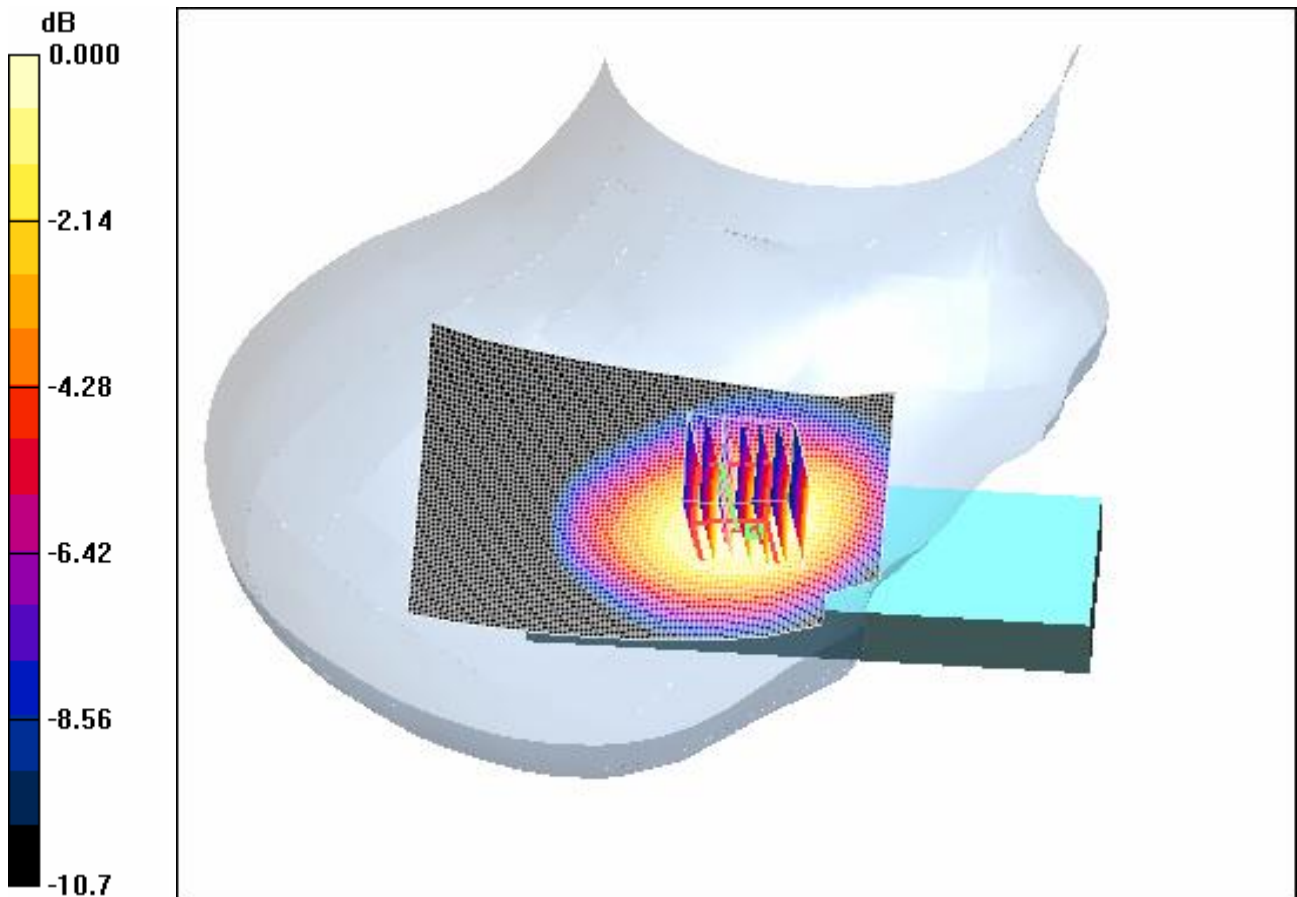

0 dB = 1.36mW/g

#### 4.11 GSM850-Body-Worn -Low-BYD

Date/Time: 2008-5-28 9:52:49

Test Laboratory: SGS-GSM

GSM850-Body-Worn-Low-2.0cm-BYD

DUT: KJ006AA01; Type: Head; Serial: 20080227

Communication System: GSM850-GSM Mode; Frequency: 824.2 MHz; Duty Cycle: 1:8.3

Medium: HSL 850\_Body Medium parameters used:  $f = 824.2$  MHz;  $\sigma = 0.964$  mho/m;  $\epsilon_r = 53.2$ ;  $\rho = 1000$  kg/m<sup>3</sup>

Phantom section: Flat Section

**DASY4 Configuration:**

- Probe: ES3DV3 - SN3088; ConvF(5.81, 5.81, 5.81); Calibrated: 2008-1-18
- Sensor-Surface: 4mm (Mechanical Surface Detection)
- Electronics: DAE3 Sn569; Calibrated: 2007-11-19
- Phantom: SAM 12; Type: SAM V4.0; Serial: TP-1283
- Measurement SW: DASY4, V4.7 Build 44; Postprocessing SW: SEMCAD, V1.8 Build 171

**Body Worn - Low BYD/Area Scan (51x91x1):** Measurement grid: dx=15mm, dy=15mm  
Maximum value of SAR (interpolated) = 0.872 mW/g

**Body Worn - Low BYD/Zoom Scan (7x7x7) (7x7x7)/Cube 0:** Measurement grid: dx=5mm,  
dy=5mm, dz=5mm

Reference Value = 8.35 V/m; Power Drift = 0.016 dB

Peak SAR (extrapolated) = 1.09 W/kg

SAR(1 g) = 0.818 mW/g; SAR(10 g) = 0.584 mW/g

Maximum value of SAR (measured) = 0.868 mW/g

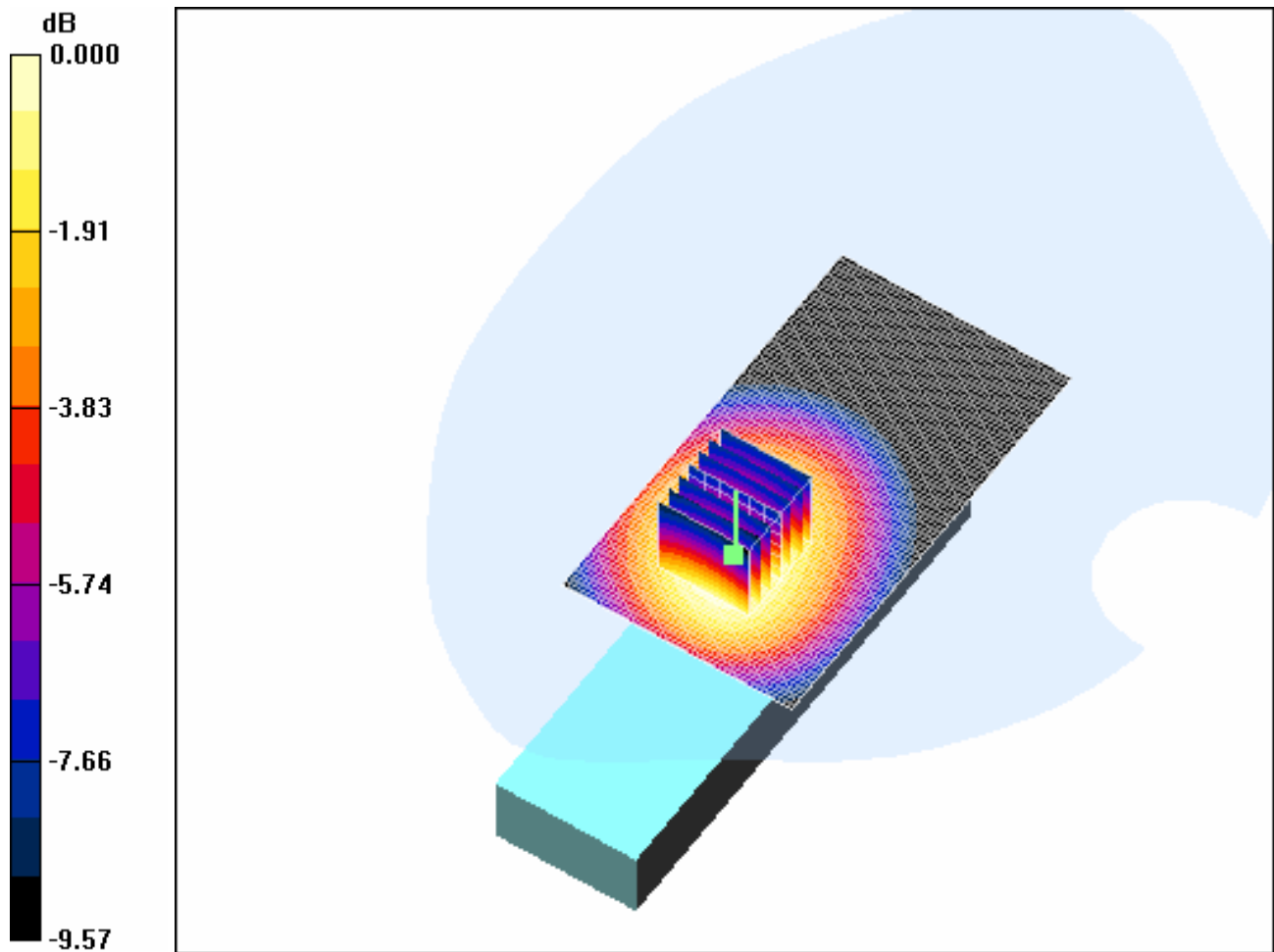

0 dB = 0.868mW/g

#### 4.12 GSM850-Body-Worn -Middle-BYD

Date/Time: 2008-5-28 9:26:20

Test Laboratory: SGS-GSM

GSM850-Body-Worn-Mid-2.0cm-BYD

DUT: KJ006AA01; Type: Head; Serial: 20080227

Communication System: GSM850-GSM Mode; Frequency: 836.4 MHz; Duty Cycle: 1:8.3

Medium: HSL 850\_Body Medium parameters used:  $f = 836.4$  MHz;  $\sigma = 0.98$  mho/m;  $\epsilon_r = 53.1$ ;  $\rho =$

1000 kg/m<sup>3</sup>

Phantom section: Flat Section

**DASY4 Configuration:**

- Probe: ES3DV3 - SN3088; ConvF(5.81, 5.81, 5.81); Calibrated: 2008-1-18
- Sensor-Surface: 4mm (Mechanical Surface Detection)
- Electronics: DAE3 Sn569; Calibrated: 2007-11-19
- Phantom: SAM 12; Type: SAM V4.0; Serial: TP-1283
- Measurement SW: DASY4, V4.7 Build 44; Postprocessing SW: SEMCAD, V1.8 Build 171

**Body Worn - Middle BYD/Area Scan (51x91x1):** Measurement grid: dx=15mm, dy=15mm

Maximum value of SAR (interpolated) = 0.719 mW/g

**Body Worn - Middle BYD/Zoom Scan (7x7x7)/Cube 0:** Measurement grid: dx=5mm, dy=5mm, dz=5mm

Reference Value = 7.57 V/m; Power Drift = 0.007 dB

Peak SAR (extrapolated) = 0.904 W/kg

SAR(1 g) = 0.677 mW/g; SAR(10 g) = 0.483 mW/g

Maximum value of SAR (measured) = 0.718 mW/g

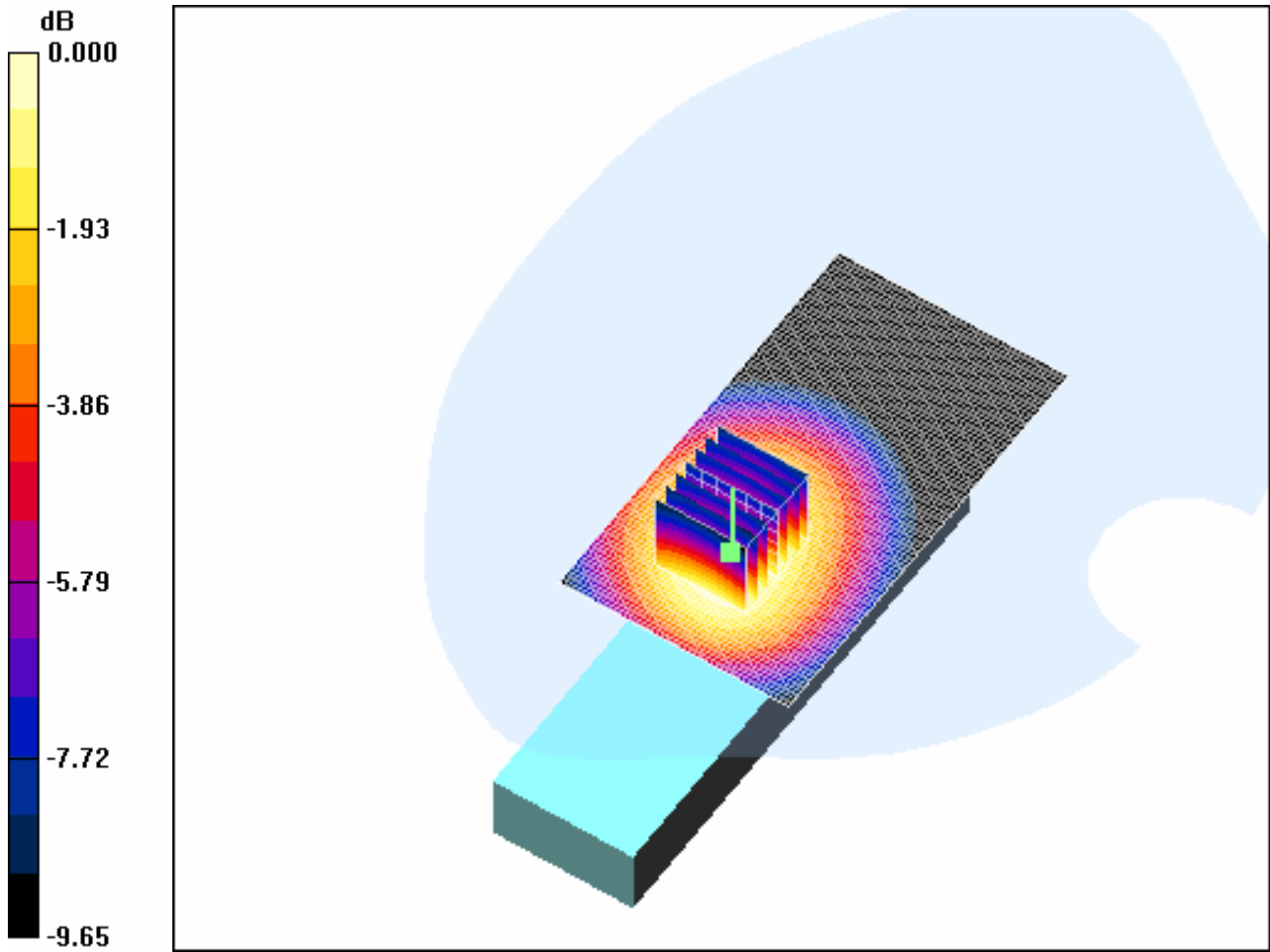

0 dB = 0.718mW/g

#### 4.13 GSM850-Body-Worn -High-BYD

Date/Time: 2008-5-28 10:16:14

Test Laboratory: SGS-GSM

GSM850-Body-Worn-High-2.0cm-BYD

DUT: KJ006AA01; Type: Head; Serial: 20080227

Communication System: GSM850-GSM Mode; Frequency: 848.8 MHz; Duty Cycle: 1:8.3

Medium: HSL 850\_Body Medium parameters used:  $f = 848.8$  MHz;  $\sigma = 0.994$  mho/m;  $\epsilon_r = 53.1$ ;  $\rho =$

1000 kg/m<sup>3</sup>

Phantom section: Flat Section

**DASY4 Configuration:**

- Probe: ES3DV3 - SN3088; ConvF(5.81, 5.81, 5.81); Calibrated: 2008-1-18
- Sensor-Surface: 4mm (Mechanical Surface Detection)
- Electronics: DAE3 Sn569; Calibrated: 2007-11-19
- Phantom: SAM 12; Type: SAM V4.0; Serial: TP-1283
- Measurement SW: DASY4, V4.7 Build 44; Postprocessing SW: SEMCAD, V1.8 Build 171

**Body Worn - High BYD/Area Scan (51x91x1): Measurement grid: dx=15mm, dy=15mm**

Maximum value of SAR (interpolated) = 0.657 mW/g

**Body Worn - High BYD/Zoom Scan (7x7x7) (7x7x7)/Cube 0: Measurement grid: dx=5mm, dy=5mm, dz=5mm**

Reference Value = 7.10 V/m; Power Drift = 0.057 dB

Peak SAR (extrapolated) = 0.823 W/kg

SAR(1 g) = 0.613 mW/g; SAR(10 g) = 0.437 mW/g

Maximum value of SAR (measured) = 0.653 mW/g

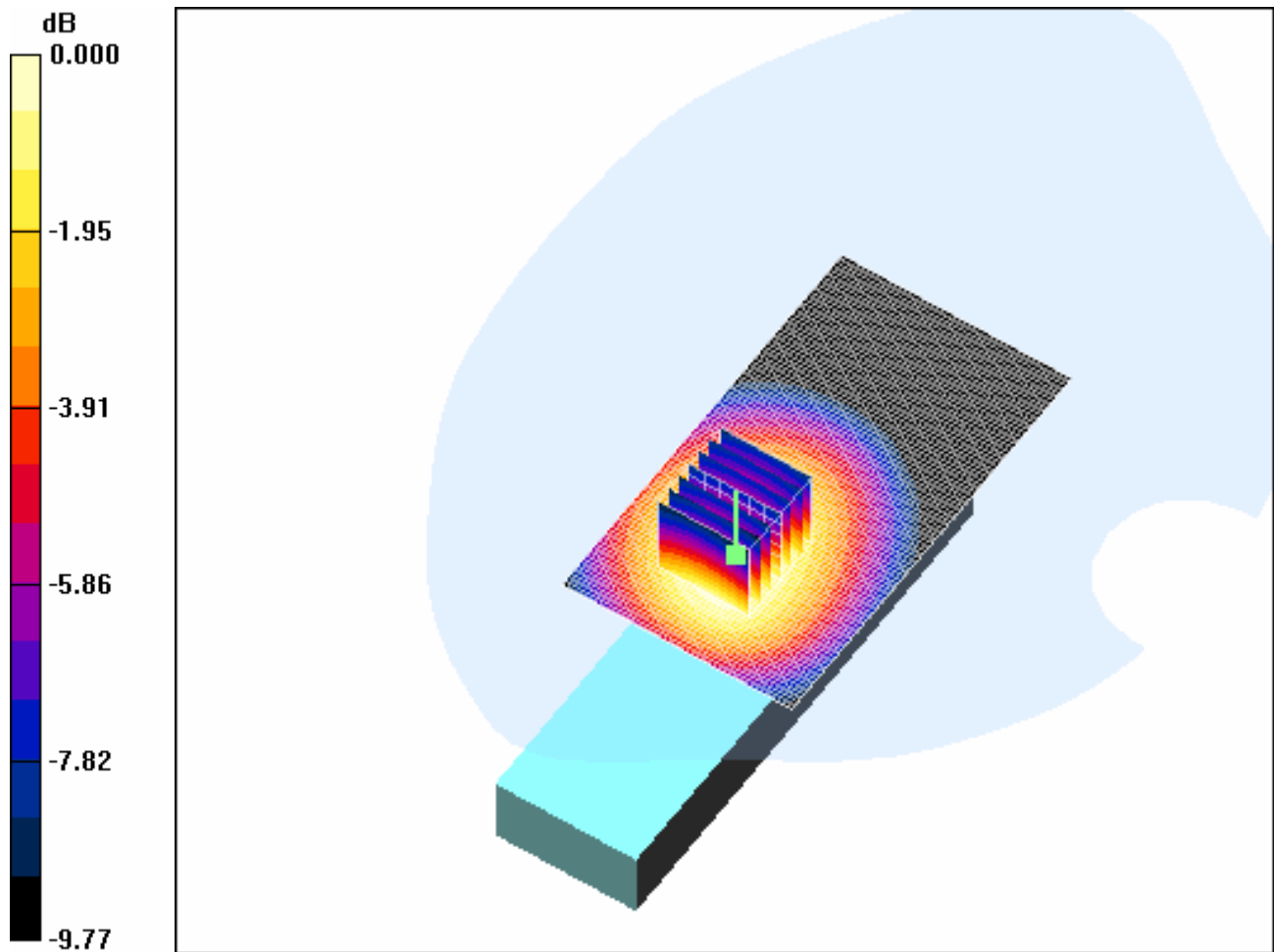

0 dB = 0.653mW/g

#### 4.14 GSM850-Body-Worn -Low-Coslight

Date/Time: 2008-5-28 13:46:53

Test Laboratory: SGS-GSM

GSM850-Body-Worn-Low-2.0cm-Coslight

DUT: KJ006AA01; Type: Head; Serial: 20080227

Communication System: GSM850-GSM Mode; Frequency: 824.2 MHz;Duty Cycle: 1:8.3

Medium: HSL 850\_Body Medium parameters used:  $f = 824.2$  MHz;  $\sigma = 0.964$  mho/m;  $\epsilon_r = 53.2$ ;  $\rho =$

1000 kg/m<sup>3</sup>

Phantom section: Flat Section

**DASY4 Configuration:**

- Probe: ES3DV3 - SN3088; ConvF(5.81, 5.81, 5.81); Calibrated: 2008-1-18
- Sensor-Surface: 4mm (Mechanical Surface Detection)
- Electronics: DAE3 Sn569; Calibrated: 2007-11-19
- Phantom: SAM 12; Type: SAM V4.0; Serial: TP-1283
- Measurement SW: DASY4, V4.7 Build 44; Postprocessing SW: SEMCAD, V1.8 Build 171

**Body Worn Low Coslight/Area Scan (51x91x1):** Measurement grid: dx=15mm, dy=15mm

Maximum value of SAR (interpolated) = 0.913 mW/g

**Body Worn Low Coslight/Zoom Scan (7x7x7) (7x7x7)/Cube 0:** Measurement grid: dx=5mm, dy=5mm, dz=5mm

Reference Value = 12.8 V/m; Power Drift = -0.097 dB

Peak SAR (extrapolated) = 1.13 W/kg

SAR(1 g) = 0.852 mW/g; SAR(10 g) = 0.608 mW/g

Maximum value of SAR (measured) = 0.906 mW/g



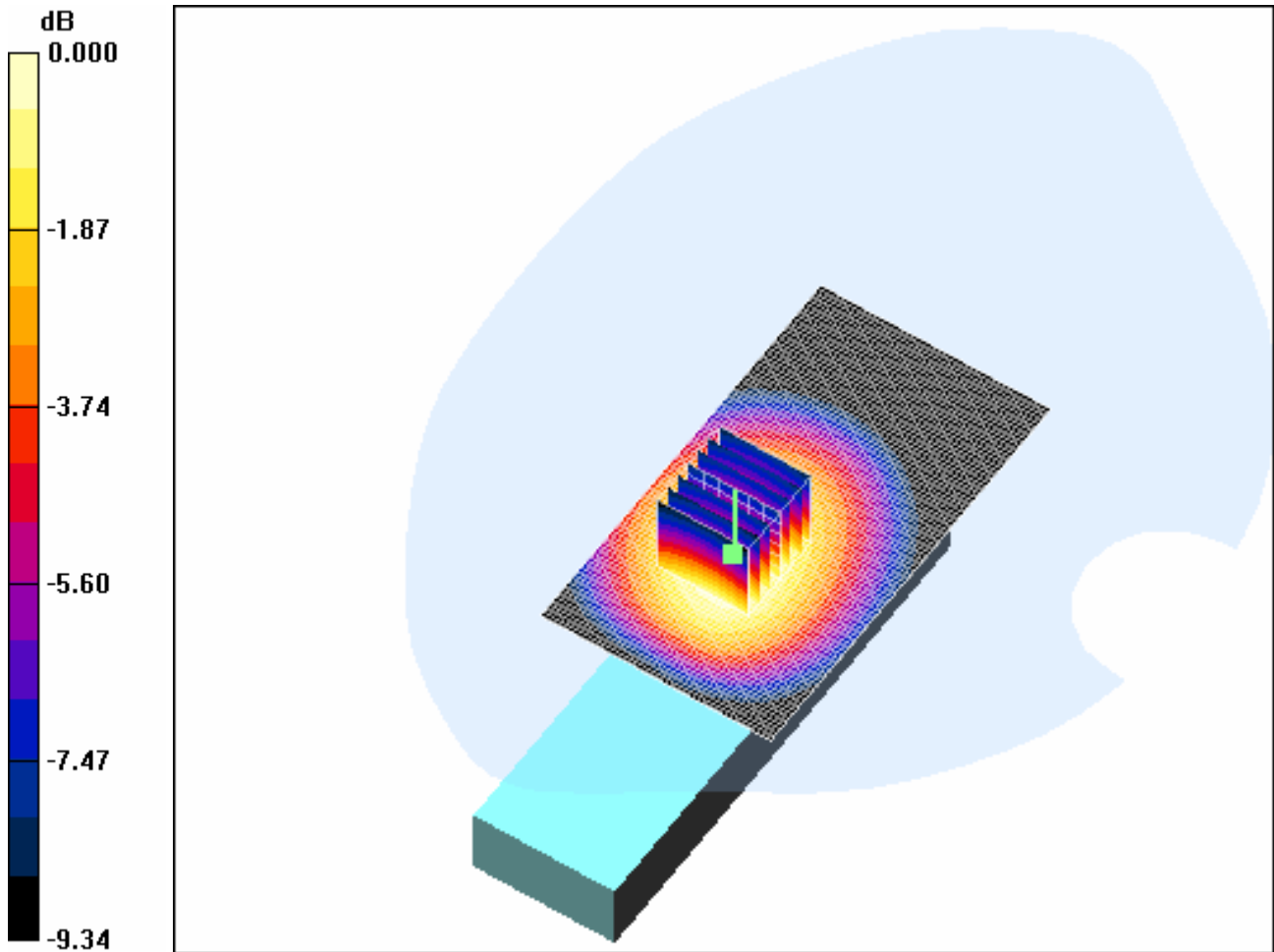

0 dB = 0.906mW/g

#### **4.15 PCS1900-LeftHandSide-Cheek-Middle-BYD**

Date/Time: 2008-4-10 18:22:53

Test Laboratory: SGS-GSM

PCS1900-LeftHandSide-Cheek-Middle-BYD

DUT: KJ006AA01; Type: Head; Serial: 01145300001024-7

Communication System: PCS1900-GSM Mode; Frequency: 1880 MHz; Duty Cycle: 1:8.3

Medium: HSL1900\_Head Medium parameters used:  $f = 1880$  MHz;  $\sigma = 1.4$  mho/m;  $\epsilon_r = 39$ ;  $\rho = 1000$

kg/m<sup>3</sup>

Phantom section: Left Section

**DASY4 Configuration:**

- Probe: ES3DV3 - SN3088; ConvF(4.84, 4.84, 4.84); Calibrated: 2008-1-18
- Sensor-Surface: 4mm (Mechanical Surface Detection)
- Electronics: DAE3 Sn569; Calibrated: 2007-11-19
- Phantom: SAM 12; Type: SAM V4.0; Serial: TP-1283
- Measurement SW: DASY4, V4.7 Build 44; Postprocessing SW: SEMCAD, V1.8 Build 171

**Cheek position - Middle BYD/Area Scan (61x91x1): Measurement grid: dx=15mm, dy=15mm**

Maximum value of SAR (interpolated) = 0.921 mW/g

**Cheek position - Middle BYD/Zoom Scan (7x7x7)/Cube 0: Measurement grid: dx=5mm, dy=5mm, dz=5mm**

Reference Value = 6.42 V/m; Power Drift = 0.033 dB

Peak SAR (extrapolated) = 1.32 W/kg

SAR(1 g) = 0.831 mW/g; SAR(10 g) = 0.496 mW/g

Maximum value of SAR (measured) = 0.911 mW/g

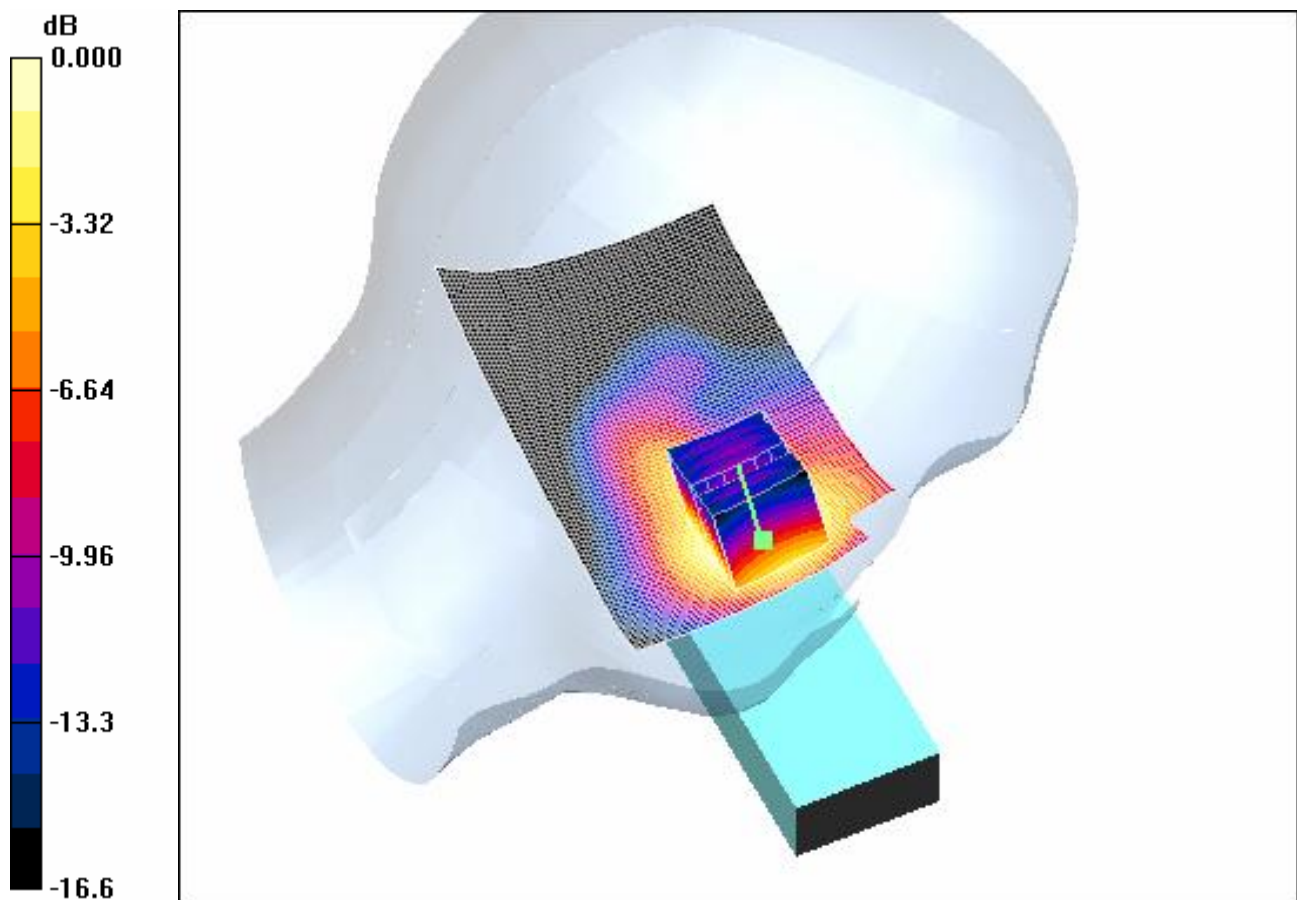

0 dB = 0.911mW/g

#### 4.16 PCS1900-LeftHandSide-Tilt-Middle-BYD

Date/Time: 2008-4-10 17:50:59

Test Laboratory: SGS-GSM

PCS1900-LeftHandSide-Tilt-Middle-BYD

DUT: KJ006AA01; Type: Head; Serial: 01145300001024-7

Communication System: PCS1900-GSM Mode; Frequency: 1880 MHz; Duty Cycle: 1:8.3

Medium: HSL1900\_Head Medium parameters used:  $f = 1880$  MHz;  $\sigma = 1.4$  mho/m;  $\epsilon_r = 39$ ;  $\rho = 1000$  kg/m<sup>3</sup>

Phantom section: Left Section

**DASY4 Configuration:**

- Probe: ES3DV3 - SN3088; ConvF(4.84, 4.84, 4.84); Calibrated: 2008-1-18
- Sensor-Surface: 4mm (Mechanical Surface Detection)
- Electronics: DAE3 Sn569; Calibrated: 2007-11-19
- Phantom: SAM 12; Type: SAM V4.0; Serial: TP-1283
- Measurement SW: DASY4, V4.7 Build 44; Postprocessing SW: SEMCAD, V1.8 Build 171

**Tilt position - Middle BYD/Area Scan (61x91x1): Measurement grid: dx=15mm, dy=15mm**

**Maximum value of SAR (interpolated) = 0.204 mW/g**

**Tilt position - Middle BYD/Zoom Scan (7x7x7)/Cube 0: Measurement grid: dx=5mm, dy=5mm, dz=5mm**

**Reference Value = 9.68 V/m; Power Drift = 0.080 dB**

**Peak SAR (extrapolated) = 0.303 W/kg**

**SAR(1 g) = 0.193 mW/g; SAR(10 g) = 0.118 mW/g**

**Maximum value of SAR (measured) = 0.210 mW/g**

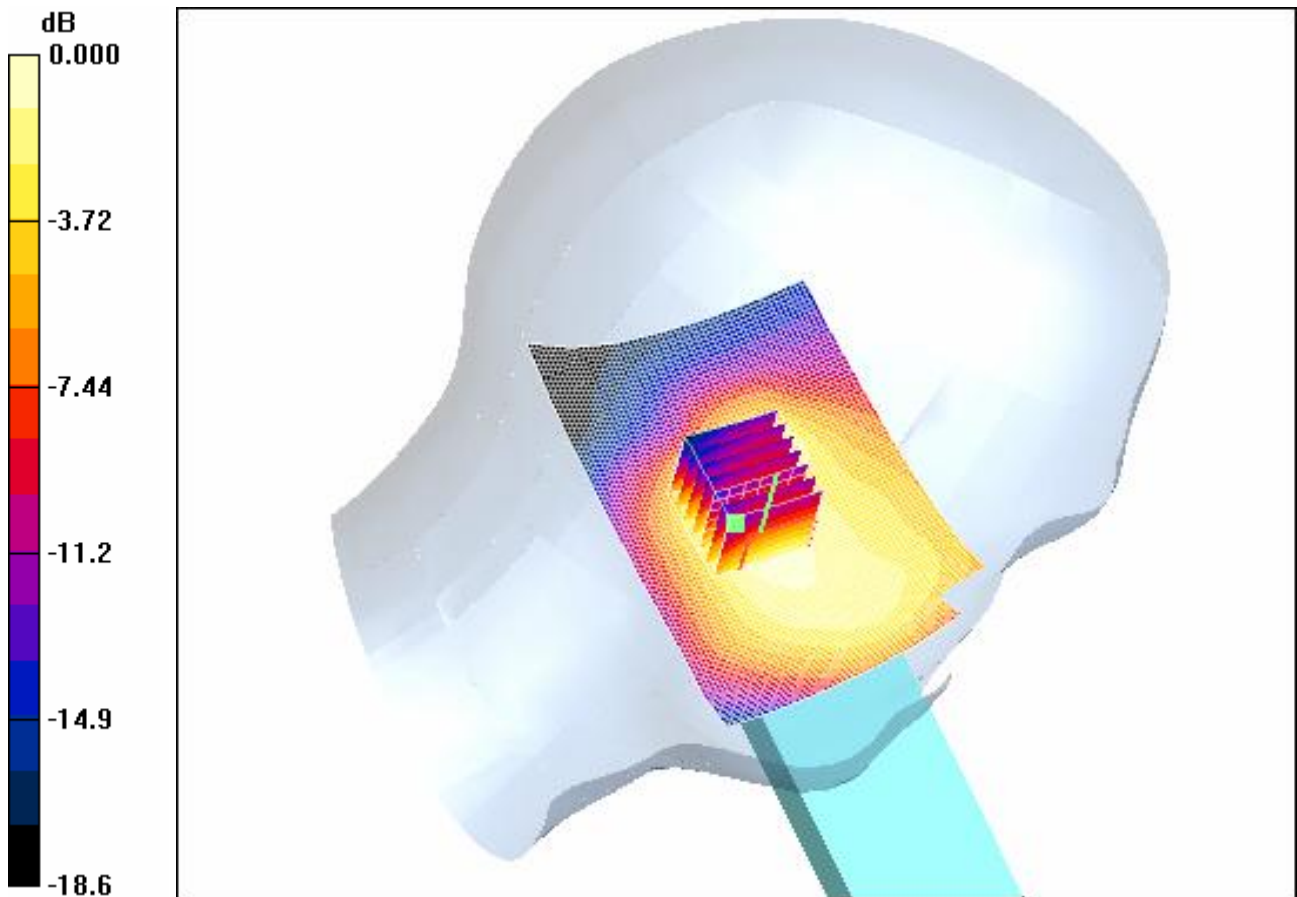

0 dB = 0.210mW/g

#### 4.17 PCS1900-LeftHandSide-Cheek-Low-BYD

Date/Time: 2008-4-10 18:48:20

Test Laboratory: SGS-GSM

PCS1900-LeftHandSide-Cheek-Low-BYD

DUT: KJ006AA01; Type: Head; Serial: 01145300001024-7

Communication System: PCS1900-GSM Mode; Frequency: 1850.2 MHz; Duty Cycle: 1:8.3

Medium: HSL1900\_Head Medium parameters used:  $f = 1850.2$  MHz;  $\sigma = 1.37$  mho/m;  $\epsilon_r = 39.1$ ;  $\rho = 1000$  kg/m<sup>3</sup>

Phantom section: Left Section

**DASY4 Configuration:**

- Probe: ES3DV3 - SN3088; ConvF(4.84, 4.84, 4.84); Calibrated: 2008-1-18
- Sensor-Surface: 4mm (Mechanical Surface Detection)
- Electronics: DAE3 Sn569; Calibrated: 2007-11-19
- Phantom: SAM 12; Type: SAM V4.0; Serial: TP-1283
- Measurement SW: DASY4, V4.7 Build 44; Postprocessing SW: SEMCAD, V1.8 Build 171

**Cheek position - Low BYD/Area Scan (61x91x1):** Measurement grid: dx=15mm, dy=15mm  
Maximum value of SAR (interpolated) = 0.933 mW/g

**Cheek position - Low BYD/Zoom Scan (7x7x7) (7x7x7)/Cube 0:** Measurement grid: dx=5mm,  
dy=5mm, dz=5mm

Reference Value = 6.68 V/m; Power Drift = 0.029 dB

Peak SAR (extrapolated) = 1.33 W/kg

SAR(1 g) = 0.836 mW/g; SAR(10 g) = 0.500 mW/g

Maximum value of SAR (measured) = 0.919 mW/g

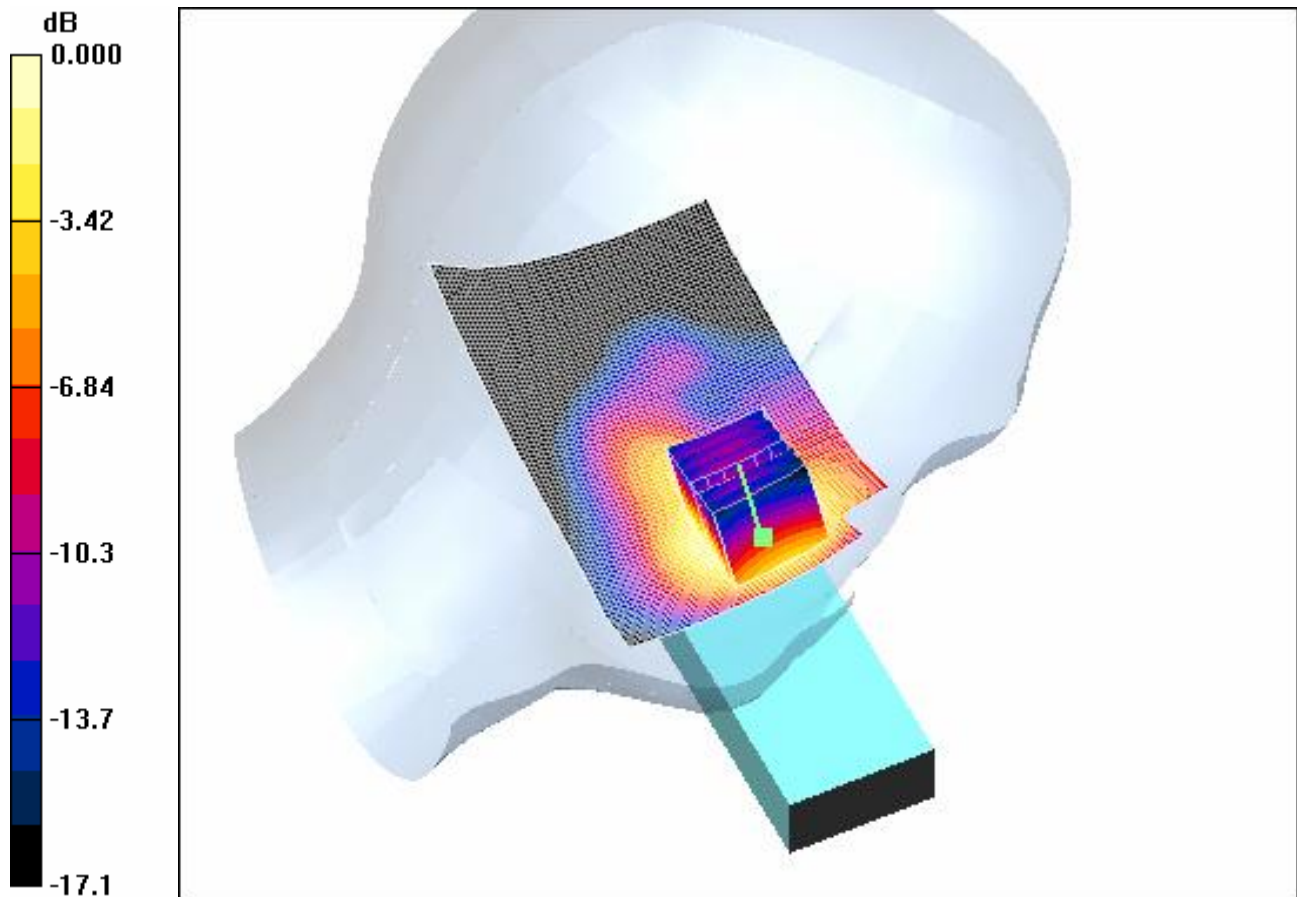

0 dB = 0.919mW/g

#### 4.18 PCS1900-LeftHandSide-Cheek-High-BYD

Date/Time: 2008-4-10 19:50:44

Test Laboratory: SGS-GSM

PCS1900-LeftHandSide-Cheek-High-BYD

DUT: KJ006AA01; Type: Head; Serial: 01145300001024-7

Communication System: PCS1900-GSM Mode; Frequency: 1909.8 MHz; Duty Cycle: 1:8.3

Medium: HSL1900\_Head Medium parameters used:  $f = 1909.8$  MHz;  $\sigma = 1.43$  mho/m;  $\epsilon_r = 38.9$ ;  $\rho = 1000$  kg/m<sup>3</sup>

Phantom section: Left Section

**DASY4 Configuration:**

- Probe: ES3DV3 - SN3088; ConvF(4.84, 4.84, 4.84); Calibrated: 2008-1-18
- Sensor-Surface: 4mm (Mechanical Surface Detection)
- Electronics: DAE3 Sn569; Calibrated: 2007-11-19
- Phantom: SAM 12; Type: SAM V4.0; Serial: TP-1283
- Measurement SW: DASY4, V4.7 Build 44; Postprocessing SW: SEMCAD, V1.8 Build 171

**Cheek position - High BYD/Area Scan (61x91x1):** Measurement grid: dx=15mm, dy=15mm

Maximum value of SAR (interpolated) = 0.782 mW/g

**Cheek position - High BYD/Zoom Scan (7x7x7) (7x7x7)/Cube 0:** Measurement grid: dx=5mm, dy=5mm, dz=5mm

Reference Value = 6.18 V/m; Power Drift = 0.016 dB

Peak SAR (extrapolated) = 1.13 W/kg

SAR(1 g) = 0.710 mW/g; SAR(10 g) = 0.422 mW/g

Maximum value of SAR (measured) = 0.772 mW/g



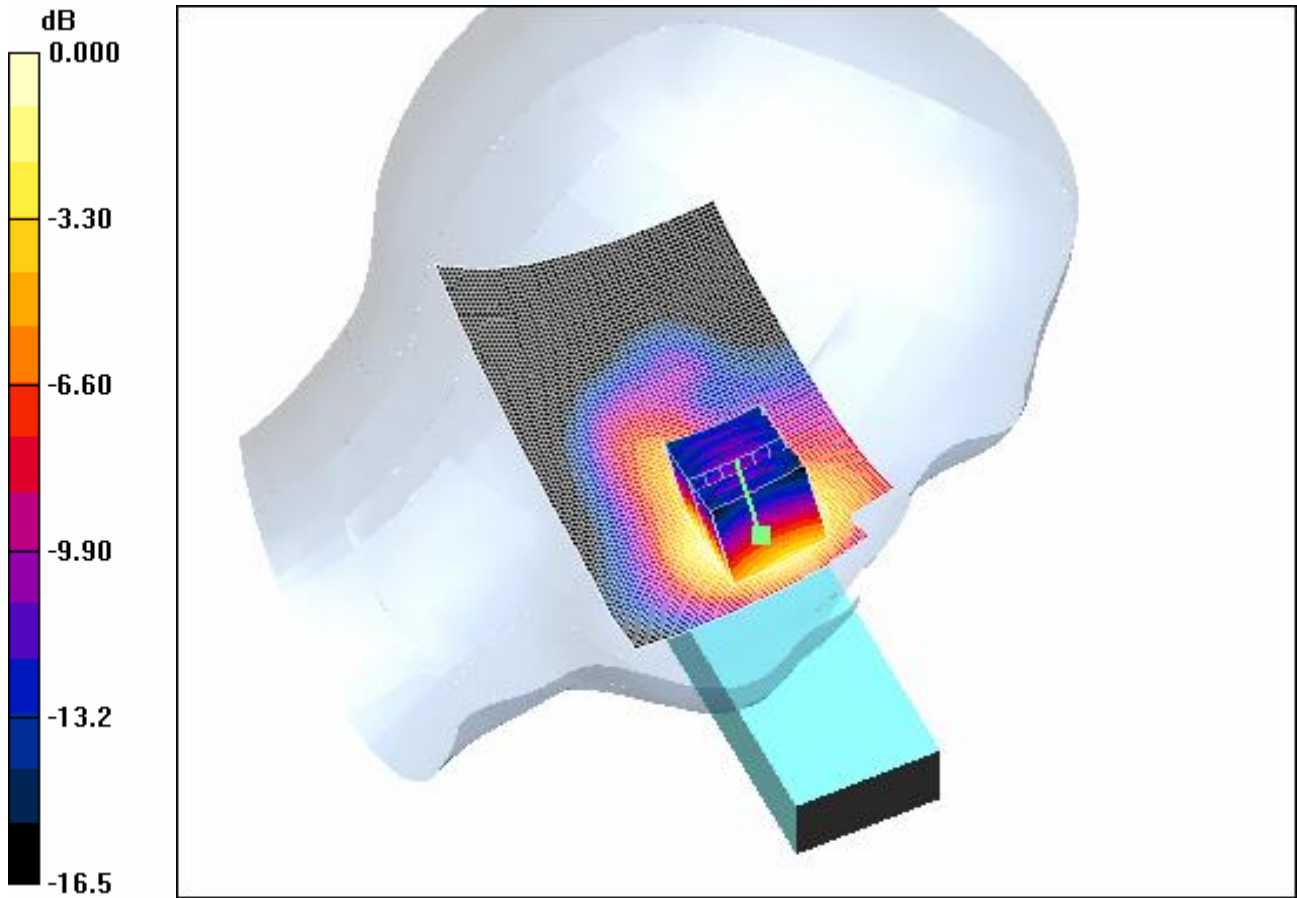

0 dB = 0.772mW/g

#### 4.19 PCS1900-LeftHandSide-Cheek-Low-Coslight

Date/Time: 2008-4-10 20:22:12

Test Laboratory: SGS-GSM

PCS1900-LeftHandSide-Cheek-Low-Coslight

DUT: KJ006AA01; Type: Head; Serial: 01145300001024-7

Communication System: PCS1900-GSM Mode; Frequency: 1850.2 MHz; Duty Cycle: 1:8.3

Medium: HSL1900\_Head Medium parameters used:  $f = 1850.2$  MHz;  $\sigma = 1.37$  mho/m;  $\epsilon_r = 39.1$ ;  $\rho = 1000$  kg/m<sup>3</sup>

Phantom section: Left Section

**DASY4 Configuration:**

- Probe: ES3DV3 - SN3088; ConvF(4.84, 4.84, 4.84); Calibrated: 2008-1-18
- Sensor-Surface: 4mm (Mechanical Surface Detection)
- Electronics: DAE3 Sn569; Calibrated: 2007-11-19
- Phantom: SAM 12; Type: SAM V4.0; Serial: TP-1283
- Measurement SW: DASY4, V4.7 Build 44; Postprocessing SW: SEMCAD, V1.8 Build 171

**Cheek position - Low Coslight/Area Scan (61x91x1):** Measurement grid: dx=15mm, dy=15mm  
Maximum value of SAR (interpolated) = 1.02 mW/g

**Cheek position - Low Coslight/Zoom Scan (7x7x7) (7x7x7)/Cube 0:** Measurement grid: dx=5mm, dy=5mm, dz=5mm

Reference Value = 7.01 V/m; Power Drift = 0.015 dB

Peak SAR (extrapolated) = 1.45 W/kg

SAR(1 g) = 0.919 mW/g; SAR(10 g) = 0.550 mW/g

Maximum value of SAR (measured) = 1.00 mW/g

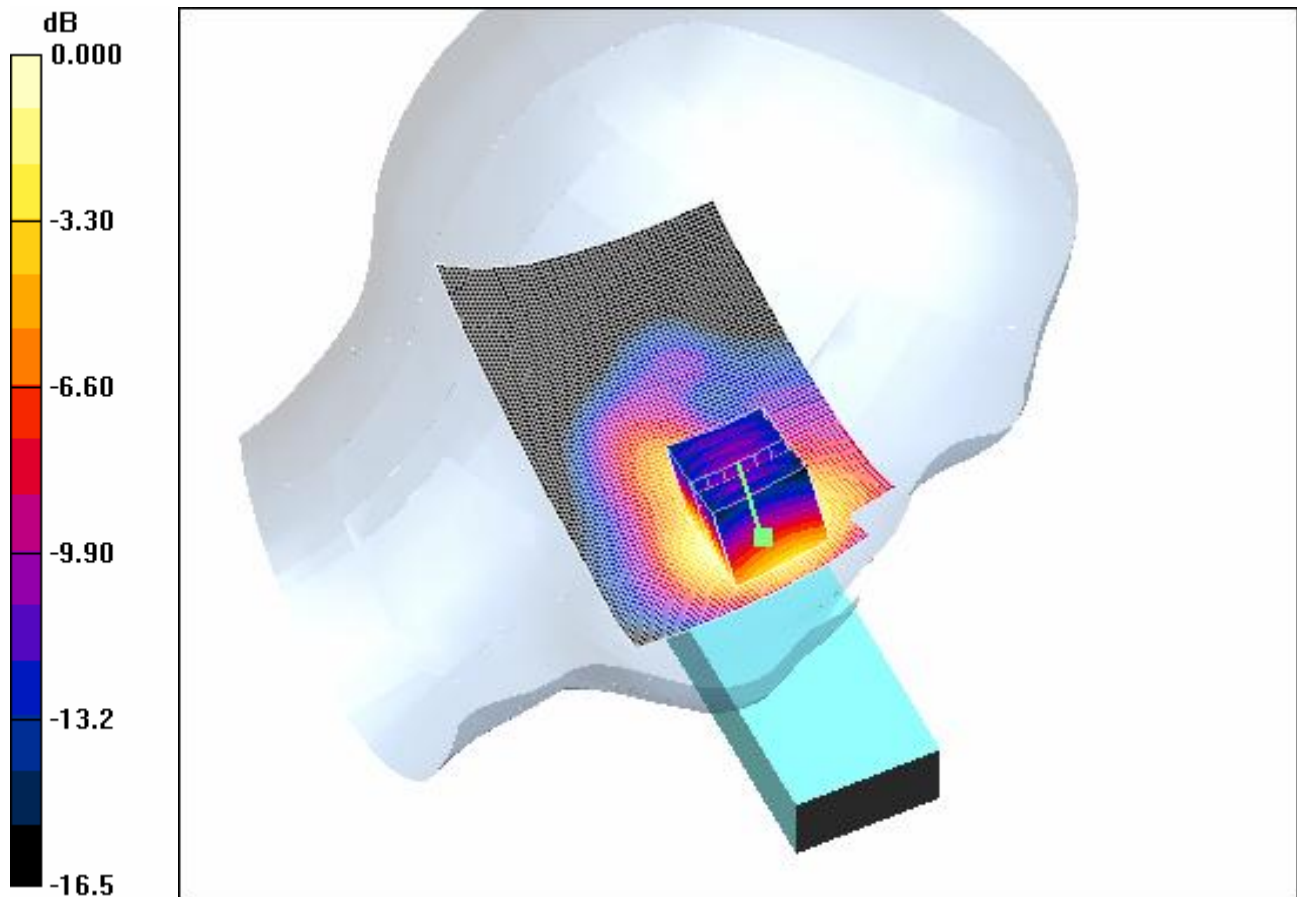

0 dB = 1.00mW/g

#### **4.20 PCS1900-RightHandSide-Cheek-Middle-BYD**

Date/Time: 2008-4-10 21:52:37

Test Laboratory: SGS-GSM

PCS1900-RightHandSide-Cheek-Middle-BYD

DUT: KJ006AA01; Type: Head; Serial: 01145300001024-7

Communication System: PCS1900-GSM Mode; Frequency: 1880 MHz; Duty Cycle: 1:8.3

Medium: HSL1900\_Head Medium parameters used:  $f = 1880$  MHz;  $\sigma = 1.4$  mho/m;  $\epsilon_r = 39$ ;  $\rho = 1000$  kg/m<sup>3</sup>

Phantom section: Right Section

**DASY4 Configuration:**

- Probe: ES3DV3 - SN3088; ConvF(4.84, 4.84, 4.84); Calibrated: 2008-1-18
- Sensor-Surface: 4mm (Mechanical Surface Detection)
- Electronics: DAE3 Sn569; Calibrated: 2007-11-19
- Phantom: SAM 12; Type: SAM V4.0; Serial: TP-1283
- Measurement SW: DASY4, V4.7 Build 44; Postprocessing SW: SEMCAD, V1.8 Build 171

**Cheek position - Middle BYD/Area Scan (61x91x1):** Measurement grid: dx=15mm, dy=15mm

Maximum value of SAR (interpolated) = 1.32 mW/g

**Cheek position - Middle BYD/Zoom Scan (7x7x7)/Cube 0:** Measurement grid: dx=5mm, dy=5mm, dz=5mm

Reference Value = 6.59 V/m; Power Drift = 0.017 dB

Peak SAR (extrapolated) = 1.91 W/kg

SAR(1 g) = 1.14 mW/g; SAR(10 g) = 0.631 mW/g

Maximum value of SAR (measured) = 1.28 mW/g

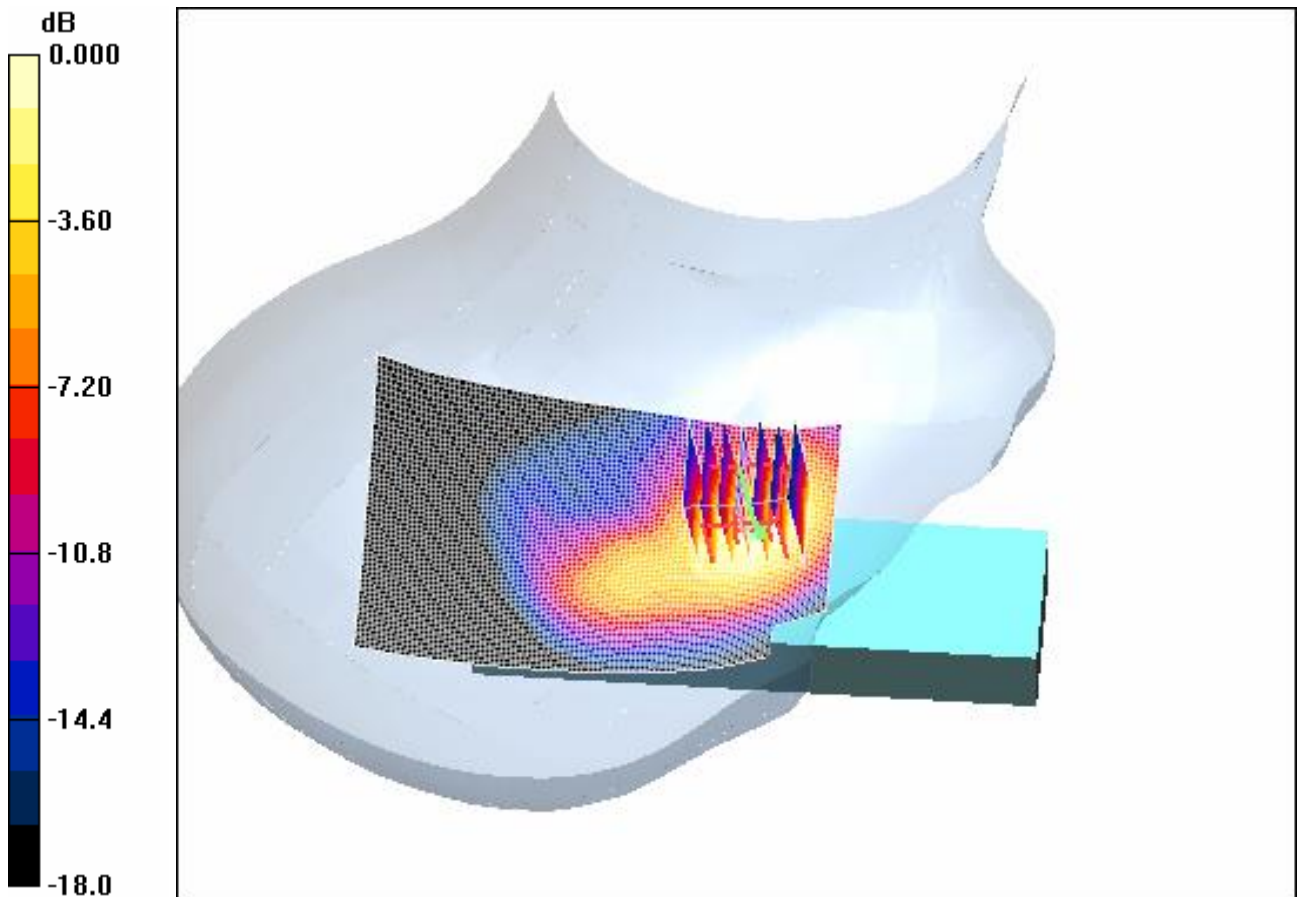

0 dB = 1.28mW/g

#### **4.21 PCS1900-RightHandSide-Tilt-Middle-BYD**

Date/Time: 2008-4-10 22:51:51

Test Laboratory: SGS-GSM

PCS1900-RightHandSide-Tilt-Middle-BYD

DUT: KJ006AA01; Type: Head; Serial: 01145300001024-7

Communication System: PCS1900-GSM Mode; Frequency: 1880 MHz; Duty Cycle: 1:8.3

Medium: HSL1900\_Head Medium parameters used:  $f = 1880$  MHz;  $\sigma = 1.4$  mho/m;  $\epsilon_r = 39$ ;  $\rho = 1000$  kg/m<sup>3</sup>

Phantom section: Right Section

**DASY4 Configuration:**

- Probe: ES3DV3 - SN3088; ConvF(4.84, 4.84, 4.84); Calibrated: 2008-1-18
- Sensor-Surface: 4mm (Mechanical Surface Detection)
- Electronics: DAE3 Sn569; Calibrated: 2007-11-19
- Phantom: SAM 12; Type: SAM V4.0; Serial: TP-1283
- Measurement SW: DASY4, V4.7 Build 44; Postprocessing SW: SEMCAD, V1.8 Build 171

**Tilt position - Middle BYD/Area Scan (61x91x1): Measurement grid: dx=15mm, dy=15mm**

**Maximum value of SAR (interpolated) = 0.269 mW/g**

**Tilt position - Middle BYD/Zoom Scan (7x7x7)/Cube 0: Measurement grid: dx=5mm, dy=5mm, dz=5mm**

**Reference Value = 9.75 V/m; Power Drift = 0.038 dB**

**Peak SAR (extrapolated) = 0.375 W/kg**

**SAR(1 g) = 0.242 mW/g; SAR(10 g) = 0.144 mW/g**

**Maximum value of SAR (measured) = 0.262 mW/g**

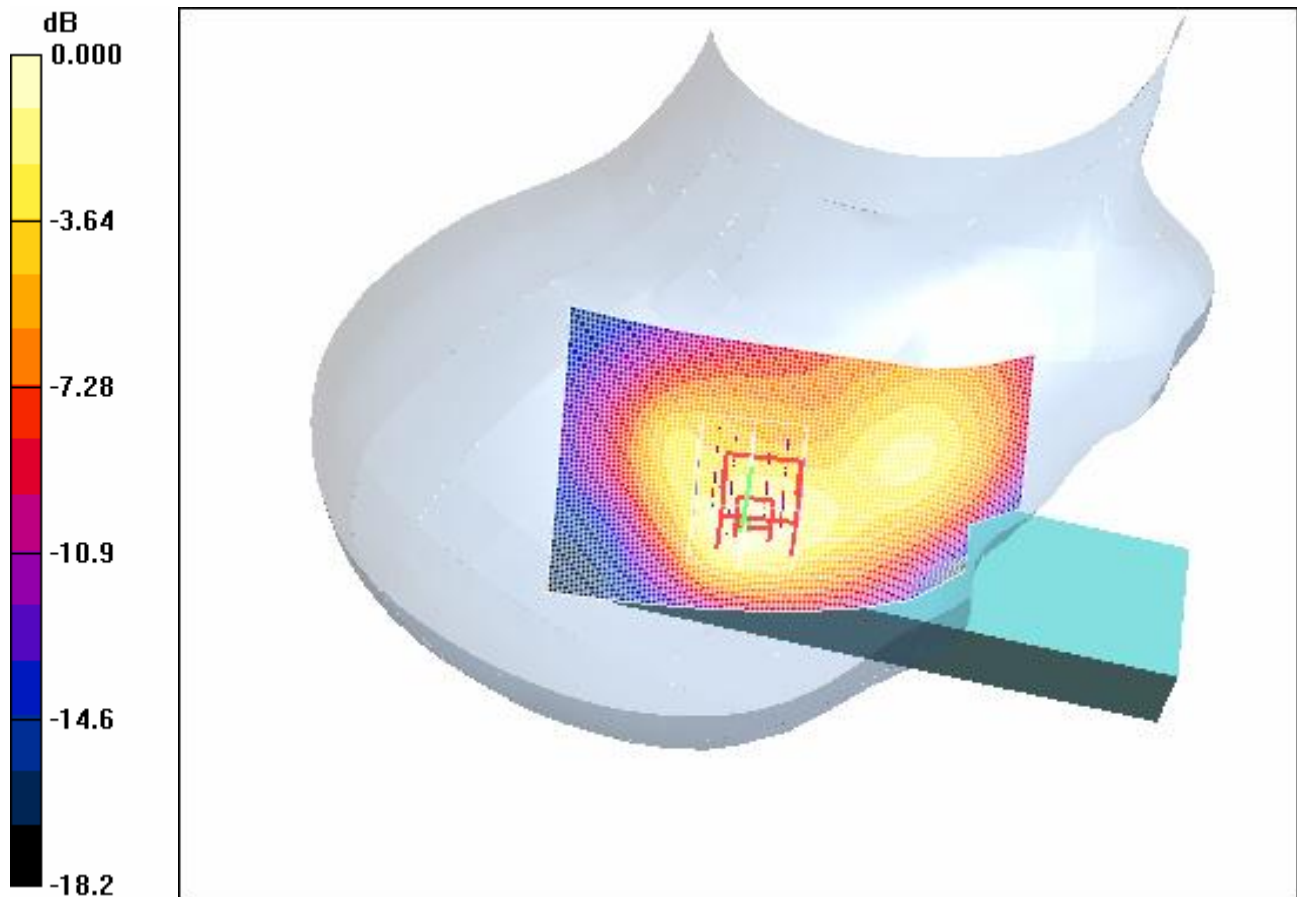

0 dB = 0.262mW/g

#### 4.22 PCS1900-RightHandSide-Cheek-Low-BYD

Date/Time: 2008-4-10 21:27:04

Test Laboratory: SGS-GSM

PCS1900-RightHandSide-Cheek-Low-BYD

DUT: KJ006AA01; Type: Head; Serial: 01145300001024-7

Communication System: PCS1900-GSM Mode; Frequency: 1850.2 MHz; Duty Cycle: 1:8.3

Medium: HSL1900\_Head Medium parameters used:  $f = 1850.2$  MHz;  $\sigma = 1.37$  mho/m;  $\epsilon_r = 39.1$ ;  $\rho = 1000$  kg/m<sup>3</sup>

Phantom section: Right Section

**DASY4 Configuration:**

- Probe: ES3DV3 - SN3088; ConvF(4.84, 4.84, 4.84); Calibrated: 2008-1-18
- Sensor-Surface: 4mm (Mechanical Surface Detection)
- Electronics: DAE3 Sn569; Calibrated: 2007-11-19
- Phantom: SAM 12; Type: SAM V4.0; Serial: TP-1283
- Measurement SW: DASY4, V4.7 Build 44; Postprocessing SW: SEMCAD, V1.8 Build 171

**Cheek position - Low BYD/Area Scan (61x91x1):** Measurement grid: dx=15mm, dy=15mm  
Maximum value of SAR (interpolated) = 1.41 mW/g

**Cheek position - Low BYD/Zoom Scan (7x7x7) (7x7x7)/Cube 0:** Measurement grid: dx=5mm,  
dy=5mm, dz=5mm

Reference Value = 7.12 V/m; Power Drift = 0.018 dB

Peak SAR (extrapolated) = 2.09 W/kg

SAR(1 g) = 1.23 mW/g; SAR(10 g) = 0.671 mW/g

Maximum value of SAR (measured) = 1.38 mW/g



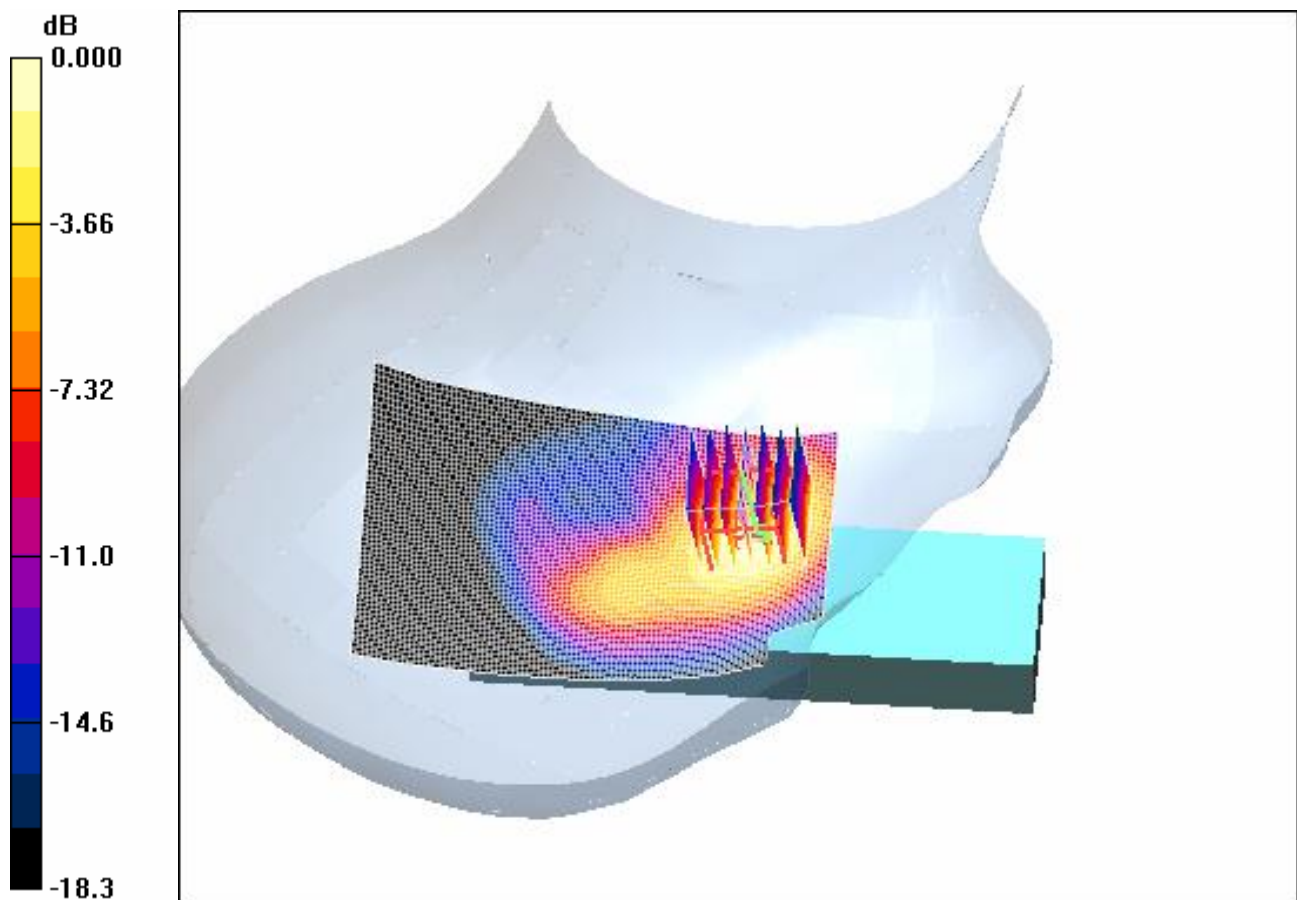

0 dB = 1.38mW/g

#### 4.23 PCS1900-RightHandSide-Cheek-High-BYD

Date/Time: 2008-4-10 22:24:25

Test Laboratory: SGS-GSM

PCS1900-RightHandSide-Cheek-High-BYD

DUT: KJ006AA01; Type: Head; Serial: 01145300001024-7

Communication System: PCS1900-GSM Mode; Frequency: 1909.8 MHz; Duty Cycle: 1:8.3

Medium: HSL1900\_Head Medium parameters used:  $f = 1909.8$  MHz;  $\sigma = 1.43$  mho/m;  $\epsilon_r = 38.9$ ;  $\rho = 1000$  kg/m<sup>3</sup>

Phantom section: Right Section

**DASY4 Configuration:**

- Probe: ES3DV3 - SN3088; ConvF(4.84, 4.84, 4.84); Calibrated: 2008-1-18
- Sensor-Surface: 4mm (Mechanical Surface Detection)
- Electronics: DAE3 Sn569; Calibrated: 2007-11-19
- Phantom: SAM 12; Type: SAM V4.0; Serial: TP-1283
- Measurement SW: DASY4, V4.7 Build 44; Postprocessing SW: SEMCAD, V1.8 Build 171

**Cheek position - High BYD/Area Scan (61x91x1):** Measurement grid: dx=15mm, dy=15mm

Maximum value of SAR (interpolated) = 1.08 mW/g

**Cheek position - High BYD/Zoom Scan (7x7x7) (7x7x7)/Cube 0:** Measurement grid: dx=5mm, dy=5mm, dz=5mm

Reference Value = 6.04 V/m; Power Drift = -0.067 dB

Peak SAR (extrapolated) = 1.60 W/kg

SAR(1 g) = 0.944 mW/g; SAR(10 g) = 0.521 mW/g

Maximum value of SAR (measured) = 1.06 mW/g

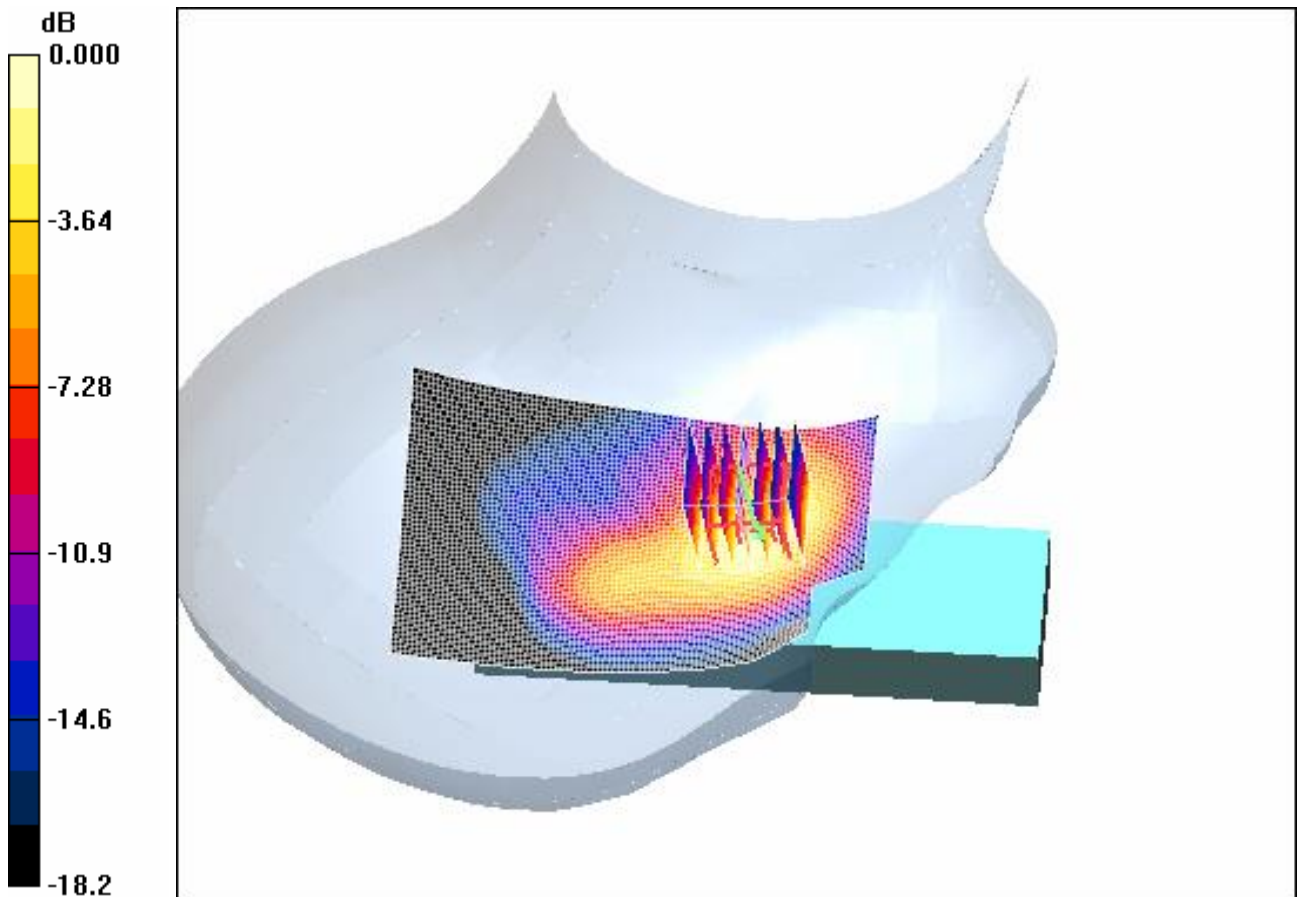

0 dB = 1.06mW/g

#### 4.24 PCS1900-RightHandSide-Cheek-Low-Coslight

Date/Time: 2008-4-10 20:59:21

Test Laboratory: SGS-GSM

PCS1900-RightHandSide-Cheek-Low-Coslight

DUT: KJ006AA01; Type: Head; Serial: 01145300001024-7

Communication System: PCS1900-GSM Mode; Frequency: 1850.2 MHz; Duty Cycle: 1:8.3

Medium: HSL1900\_Head Medium parameters used:  $f = 1850.2$  MHz;  $\sigma = 1.37$  mho/m;  $\epsilon_r = 39.1$ ;  $\rho = 1000$  kg/m<sup>3</sup>

Phantom section: Right Section

**DASY4 Configuration:**

- Probe: ES3DV3 - SN3088; ConvF(4.84, 4.84, 4.84); Calibrated: 2008-1-18
- Sensor-Surface: 4mm (Mechanical Surface Detection)
- Electronics: DAE3 Sn569; Calibrated: 2007-11-19
- Phantom: SAM 12; Type: SAM V4.0; Serial: TP-1283
- Measurement SW: DASY4, V4.7 Build 44; Postprocessing SW: SEMCAD, V1.8 Build 171

**Cheek position - Low Coslight/Area Scan (61x91x1):** Measurement grid: dx=15mm, dy=15mm  
Maximum value of SAR (interpolated) = 1.47 mW/g

**Cheek position - Low Coslight/Zoom Scan (7x7x7) (7x7x7)/Cube 0:** Measurement grid: dx=5mm, dy=5mm, dz=5mm

Reference Value = 7.18 V/m; Power Drift = 0.040 dB

Peak SAR (extrapolated) = 2.10 W/kg

SAR(1 g) = 1.26 mW/g; SAR(10 g) = 0.703 mW/g

Maximum value of SAR (measured) = 1.41 mW/g

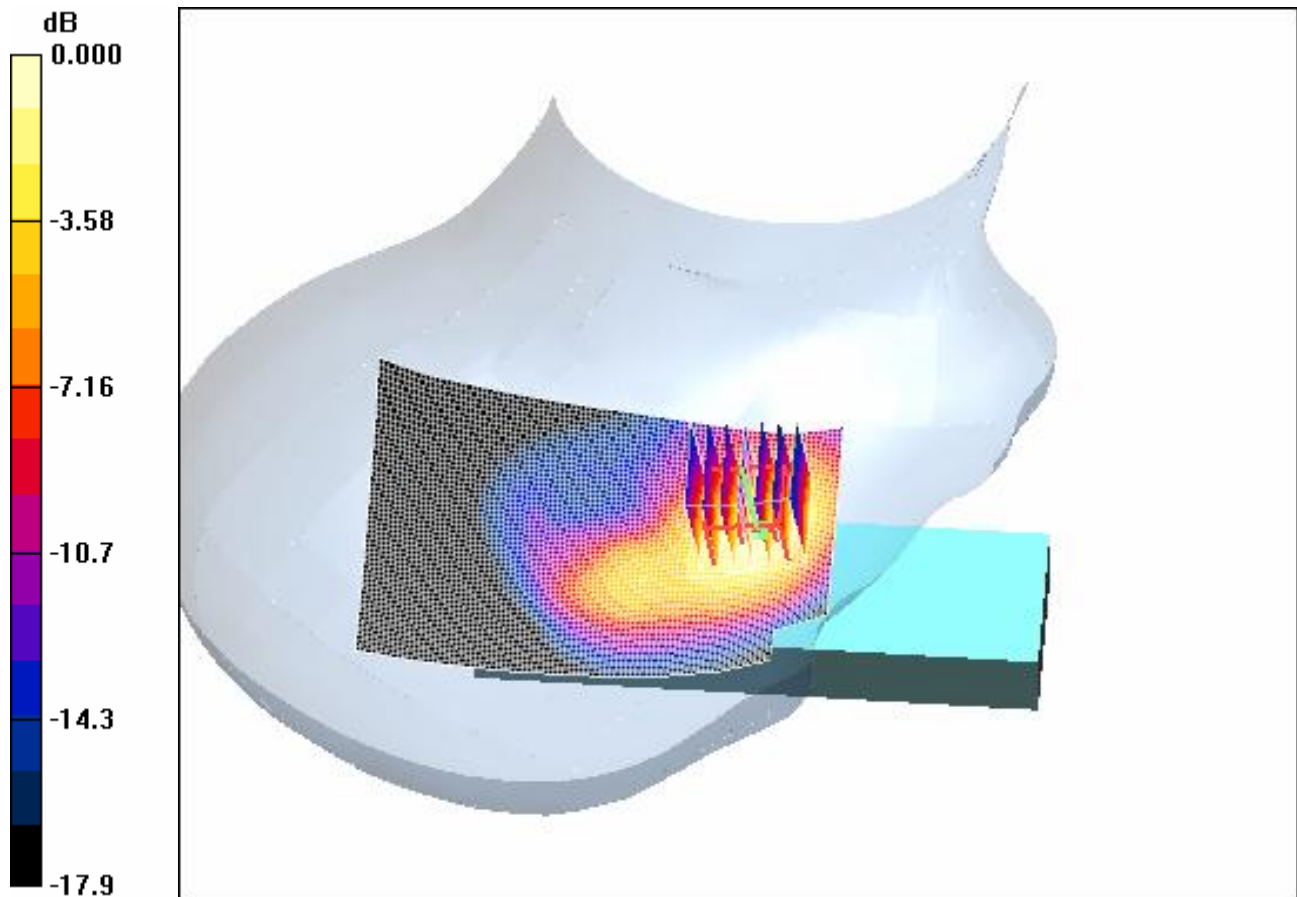

0 dB = 1.41mW/g

#### 4.25 PCS1900-Body-Worn -Low-BYD

Date/Time: 2008-5-22 13:17:05

Test Laboratory: SGS-GSM

GSM1900-Body-Worn--Low-2.0cm-BYD

DUT: KJ006AA01; Type: Head; Serial: 20080227

Communication System: PCS1900-GSM Mode; Frequency: 1850.2 MHz;Duty Cycle: 1:8.3

Medium: HSL1900\_Body Medium parameters used:  $f = 1850.2$  MHz;  $\sigma = 1.51$  mho/m;  $\epsilon_r = 51.9$ ;  $\rho = 1000$  kg/m<sup>3</sup>

Phantom section: Flat Section

**DASY4 Configuration:**

- Probe: ES3DV3 - SN3088; ConvF(4.6, 4.6, 4.6); Calibrated: 2008-1-18
- Sensor-Surface: 4mm (Mechanical Surface Detection)
- Electronics: DAE3 Sn569; Calibrated: 2007-11-19
- Phantom: SAM 12; Type: SAM V4.0; Serial: TP-1283
- Measurement SW: DASY4, V4.7 Build 44; Postprocessing SW: SEMCAD, V1.8 Build 171

**Body Worn - Low BYD/Area Scan (51x91x1):** Measurement grid: dx=15mm, dy=15mm  
Maximum value of SAR (interpolated) = 0.663 mW/g

**Body Worn - Low BYD/Zoom Scan (7x7x7)/Cube 0:** Measurement grid: dx=5mm, dy=5mm,  
dz=5mm

Reference Value = 6.05 V/m; Power Drift = -0.090 dB

Peak SAR (extrapolated) = 1.03 W/kg

SAR(1 g) = 0.582 mW/g; SAR(10 g) = 0.324 mW/g

Maximum value of SAR (measured) = 0.640 mW/g

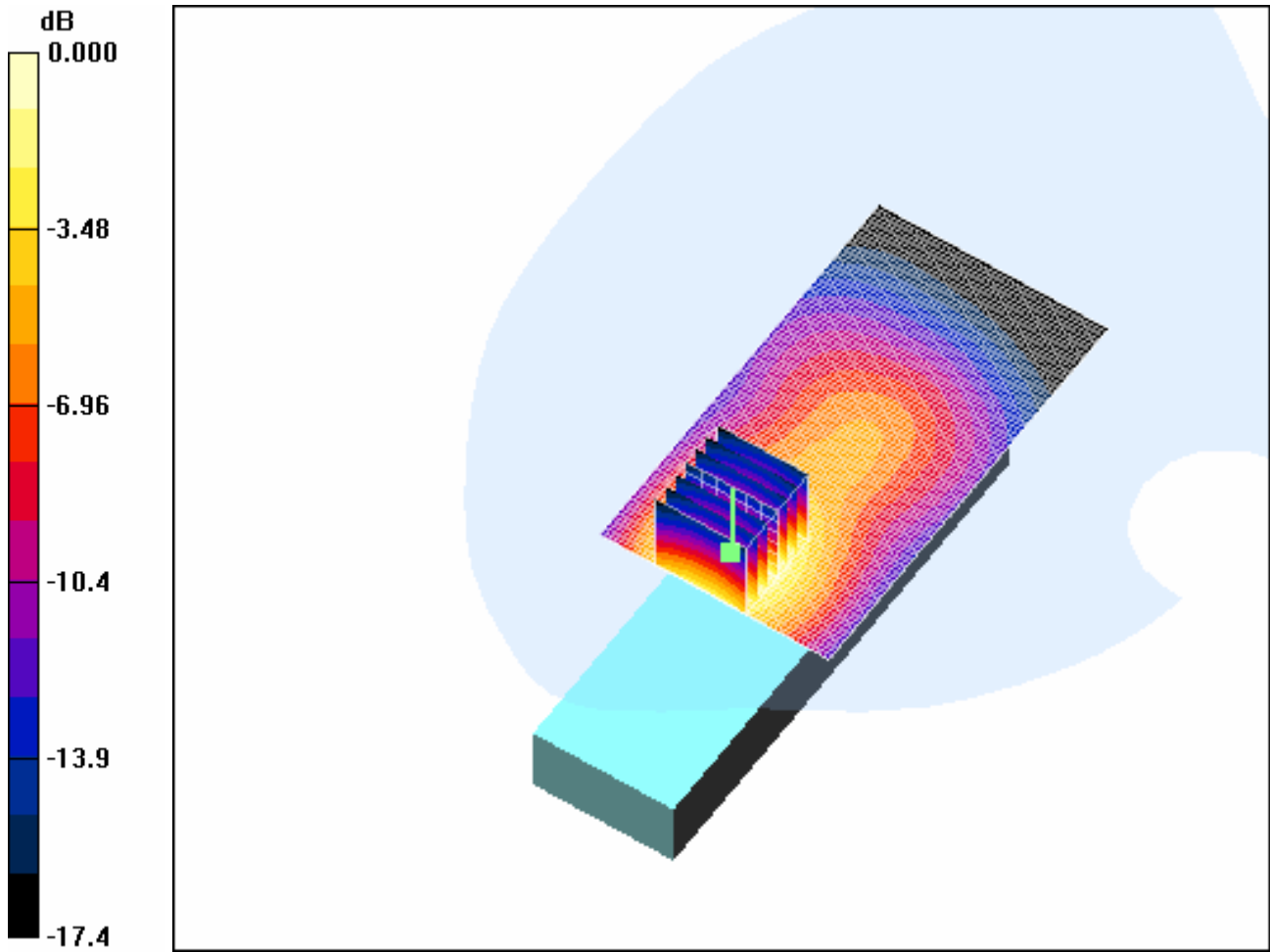

0 dB = 0.640mW/g

#### **4.26 PCS1900-Body-Worn -Middle-BYD**

Date/Time: 2008-5-22 13:39:18

Test Laboratory: SGS-GSM

GSM1900-Body-Worn--Mid-2.0cm-BYD

DUT: KJ006AA01; Type: Head; Serial: 20080227

Communication System: PCS1900-GSM Mode; Frequency: 1880 MHz;Duty Cycle: 1:8.3

Medium: HSL1900\_Body Medium parameters used:  $f = 1880$  MHz;  $\sigma = 1.54$  mho/m;  $\epsilon_r = 51.7$ ;  $\rho =$

1000 kg/m<sup>3</sup>

Phantom section: Flat Section

**DASY4 Configuration:**

- Probe: ES3DV3 - SN3088; ConvF(4.6, 4.6, 4.6); Calibrated: 2008-1-18
- Sensor-Surface: 4mm (Mechanical Surface Detection)
- Electronics: DAE3 Sn569; Calibrated: 2007-11-19
- Phantom: SAM 12; Type: SAM V4.0; Serial: TP-1283
- Measurement SW: DASY4, V4.7 Build 44; Postprocessing SW: SEMCAD, V1.8 Build 171

**Body Worn - Middle BYD/Area Scan (51x91x1):** Measurement grid: dx=15mm, dy=15mm

Maximum value of SAR (interpolated) = 0.542 mW/g

**Body Worn - Middle BYD/Zoom Scan (7x7x7)/Cube 0:** Measurement grid: dx=5mm, dy=5mm, dz=5mm

Reference Value = 6.12 V/m; Power Drift = -0.085 dB

Peak SAR (extrapolated) = 0.878 W/kg

SAR(1 g) = 0.482 mW/g; SAR(10 g) = 0.268 mW/g

Maximum value of SAR (measured) = 0.529 mW/g



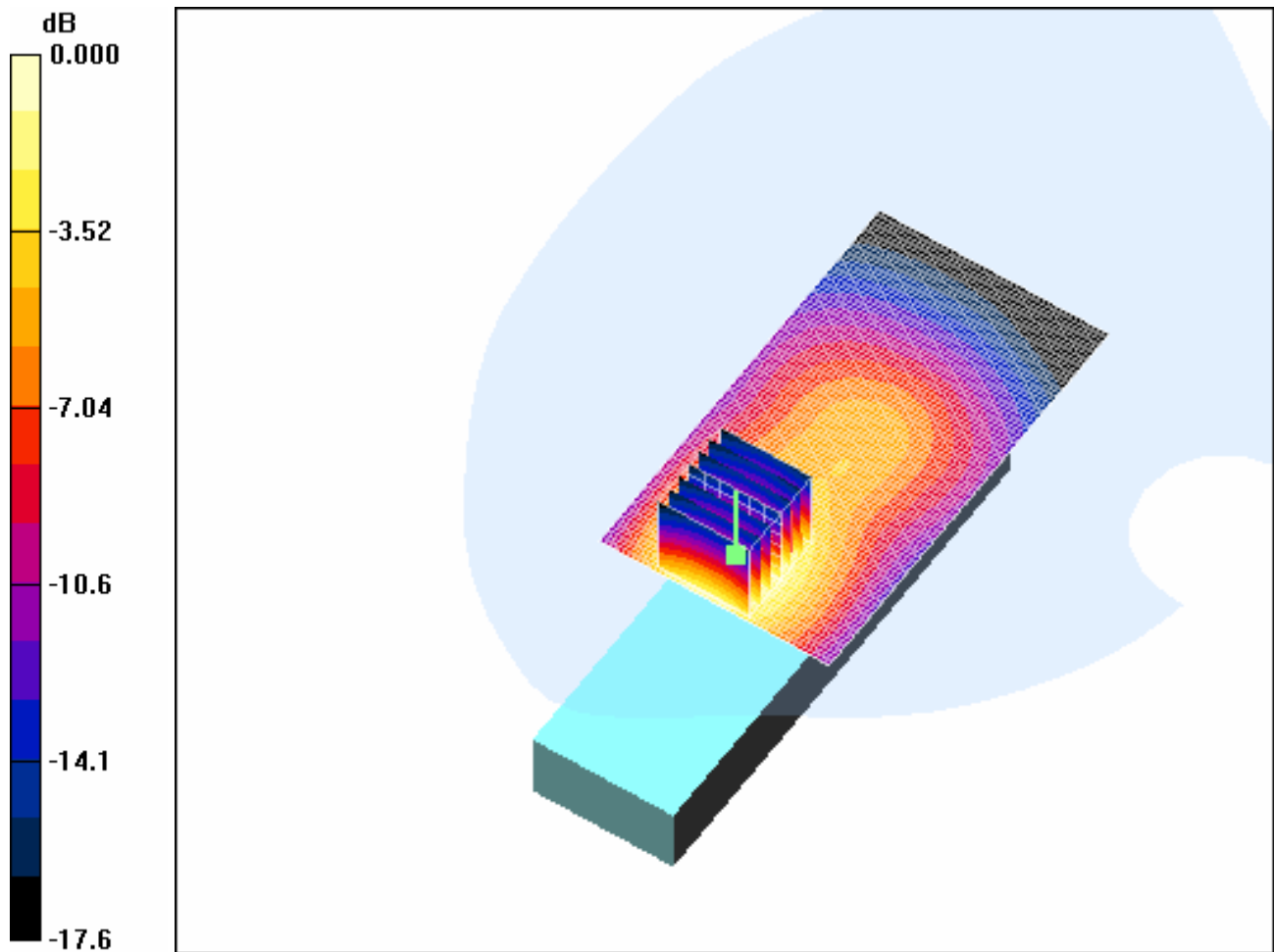

0 dB = 0.529mW/g

#### **4.27 PCS1900-Body-Worn -High-BYD**

Date/Time: 2008-5-22 14:05:36

Test Laboratory: SGS-GSM

GSM1900-Body-Worn--High-2.0cm-BYD

DUT: KJ006AA01; Type: Head; Serial: 20080227

Communication System: PCS1900-GSM Mode; Frequency: 1909.8 MHz; Duty Cycle: 1:8.3

Medium: HSL1900\_Body Medium parameters used:  $f = 1909.8$  MHz;  $\sigma = 1.57$  mho/m;  $\epsilon_r = 51.6$ ;  $\rho =$

1000 kg/m<sup>3</sup>

Phantom section: Flat Section

**DASY4 Configuration:**

- Probe: ES3DV3 - SN3088; ConvF(4.6, 4.6, 4.6); Calibrated: 2008-1-18
- Sensor-Surface: 4mm (Mechanical Surface Detection)
- Electronics: DAE3 Sn569; Calibrated: 2007-11-19
- Phantom: SAM 12; Type: SAM V4.0; Serial: TP-1283
- Measurement SW: DASY4, V4.7 Build 44; Postprocessing SW: SEMCAD, V1.8 Build 171

**Body Worn -High BYD/Area Scan (51x91x1):** Measurement grid: dx=15mm, dy=15mm

Maximum value of SAR (interpolated) = 0.440 mW/g

**Body Worn -High BYD/Zoom Scan (7x7x7)/Cube 0:** Measurement grid: dx=5mm, dy=5mm,  
dz=5mm

Reference Value = 6.13 V/m; Power Drift = -0.067 dB

Peak SAR (extrapolated) = 0.708 W/kg

SAR(1 g) = 0.392 mW/g; SAR(10 g) = 0.219 mW/g

Maximum value of SAR (measured) = 0.428 mW/g

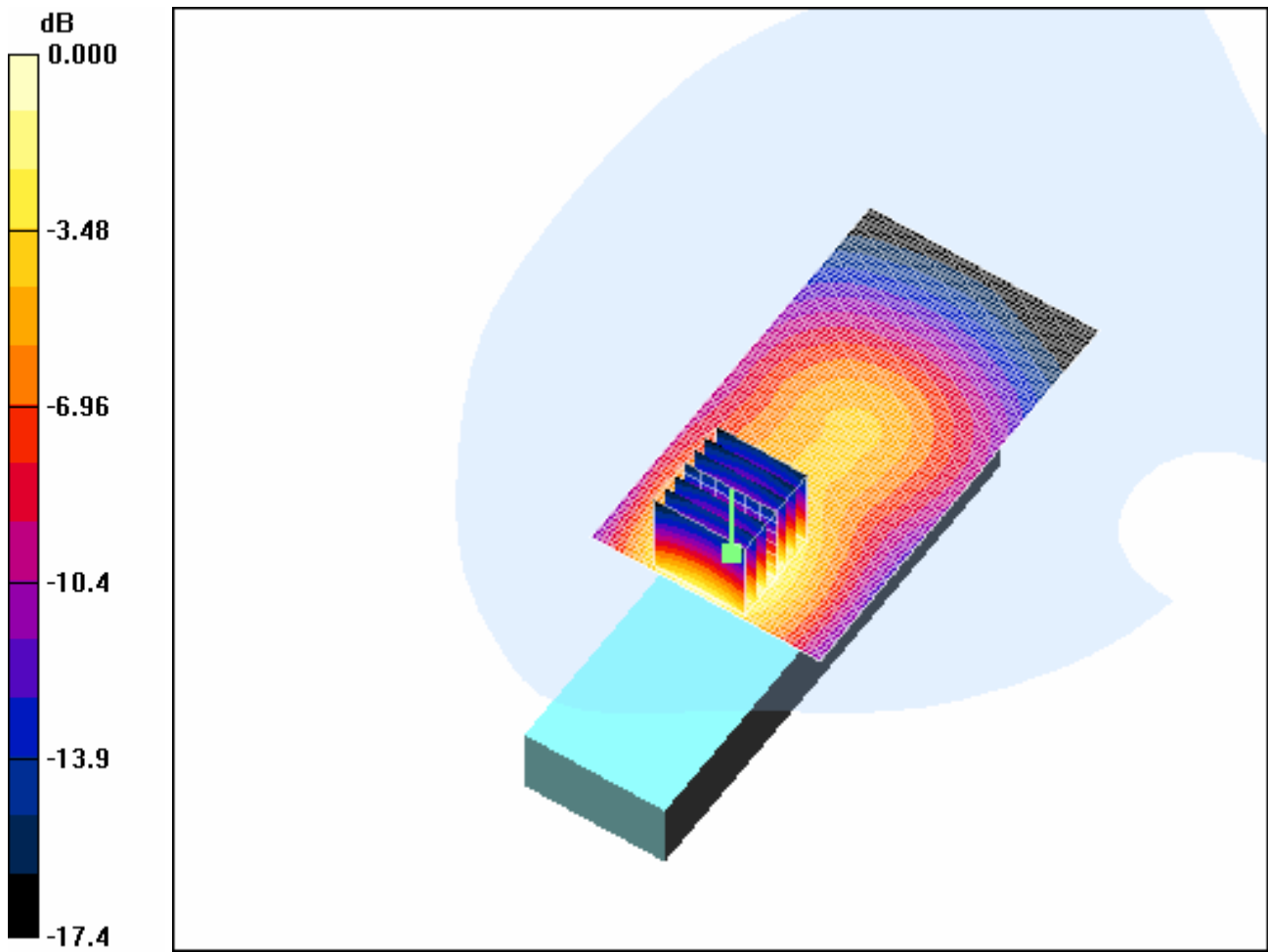

0 dB = 0.428mW/g

#### **4.28 PCS1900-Body-Worn -Low-Coslight**

Date/Time: 2008-5-22 14:40:21

Test Laboratory: SGS-GSM

GSM1900-Body-Worn--Low-2.0cm-Coslight

DUT: KJ006AA01; Type: Head; Serial: 20080227

Communication System: PCS1900-GSM Mode; Frequency: 1850.2 MHz; Duty Cycle: 1:8.3

Medium: HSL1900\_Body Medium parameters used:  $f = 1850.2$  MHz;  $\sigma = 1.51$  mho/m;  $\epsilon_r = 51.9$ ;  $\rho =$

1000 kg/m<sup>3</sup>

Phantom section: Flat Section

**DASY4 Configuration:**

- Probe: ES3DV3 - SN3088; ConvF(4.6, 4.6, 4.6); Calibrated: 2008-1-18
- Sensor-Surface: 4mm (Mechanical Surface Detection)
- Electronics: DAE3 Sn569; Calibrated: 2007-11-19
- Phantom: SAM 12; Type: SAM V4.0; Serial: TP-1283
- Measurement SW: DASY4, V4.7 Build 44; Postprocessing SW: SEMCAD, V1.8 Build 171

**Body Worn - Low Coslight/Area Scan (51x91x1):** Measurement grid: dx=15mm, dy=15mm

Maximum value of SAR (interpolated) = 0.676 mW/g

**Body Worn - Low Coslight/Zoom Scan (7x7x7)/Cube 0:** Measurement grid: dx=5mm, dy=5mm, dz=5mm

Reference Value = 7.14 V/m; Power Drift = -0.053 dB

Peak SAR (extrapolated) = 1.09 W/kg

SAR(1 g) = 0.599 mW/g; SAR(10 g) = 0.331 mW/g

Maximum value of SAR (measured) = 0.657 mW/g

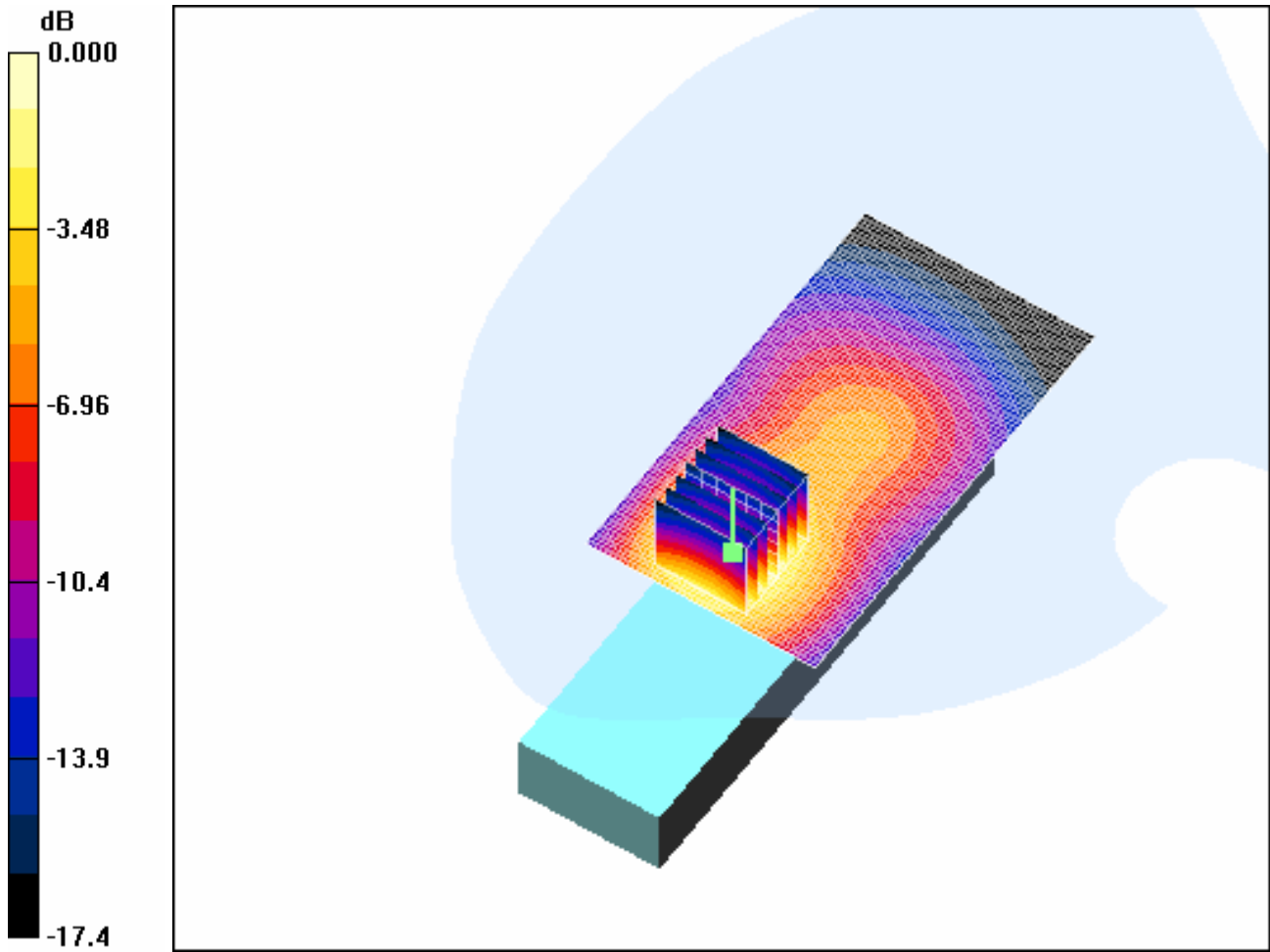

0 dB = 0.657mW/g

### ***Additional Tests***

#### ***4.29 GSM850-Flat Phantom- Head-Middle-BYD***

Date/Time: 2008-7-25 12:48:46

Test Laboratory: SGS-GSM

GSM850-Head-Worn-Mid-BYD-0.5cm

DUT: KJ006AA02; Type: Head; Serial: 20080725

Communication System: GSM850-GSM Mode; Frequency: 836.4 MHz; Duty Cycle: 1:8.3

Medium: HSL 850\_Body Medium parameters used:  $f = 836.4$  MHz;  $\sigma = 0.98$  mho/m;  $\epsilon_r = 53.1$ ;  $\rho = 1000$  kg/m<sup>3</sup>

Phantom section: Flat Section

#### DASY4 Configuration:

- Probe: ES3DV3 - SN3088; ConvF(5.81, 5.81, 5.81); Calibrated: 2008-1-18
- Sensor-Surface: 4mm (Mechanical Surface Detection)
- Electronics: DAE3 Sn569; Calibrated: 2007-11-19
- Phantom: SAM 12; Type: SAM V4.0; Serial: TP-1283
- Measurement SW: DASY4, V4.7 Build 44; Postprocessing SW: SEMCAD, V1.8 Build 171

Body Worn - Middle BYD 2/Area Scan (81x101x1): Measurement grid: dx=15mm, dy=15mm

Maximum value of SAR (interpolated) = 0.899 mW/g

Body Worn - Middle BYD 2/Zoom Scan (7x7x7)/Cube 0: Measurement grid: dx=5mm, dy=5mm, dz=5mm

Reference Value = 5.70 V/m; Power Drift = 0.062 dB

Peak SAR (extrapolated) = 1.18 W/kg

SAR(1 g) = 0.867 mW/g; SAR(10 g) = 0.593 mW/g

Maximum value of SAR (measured) = 0.929 mW/g

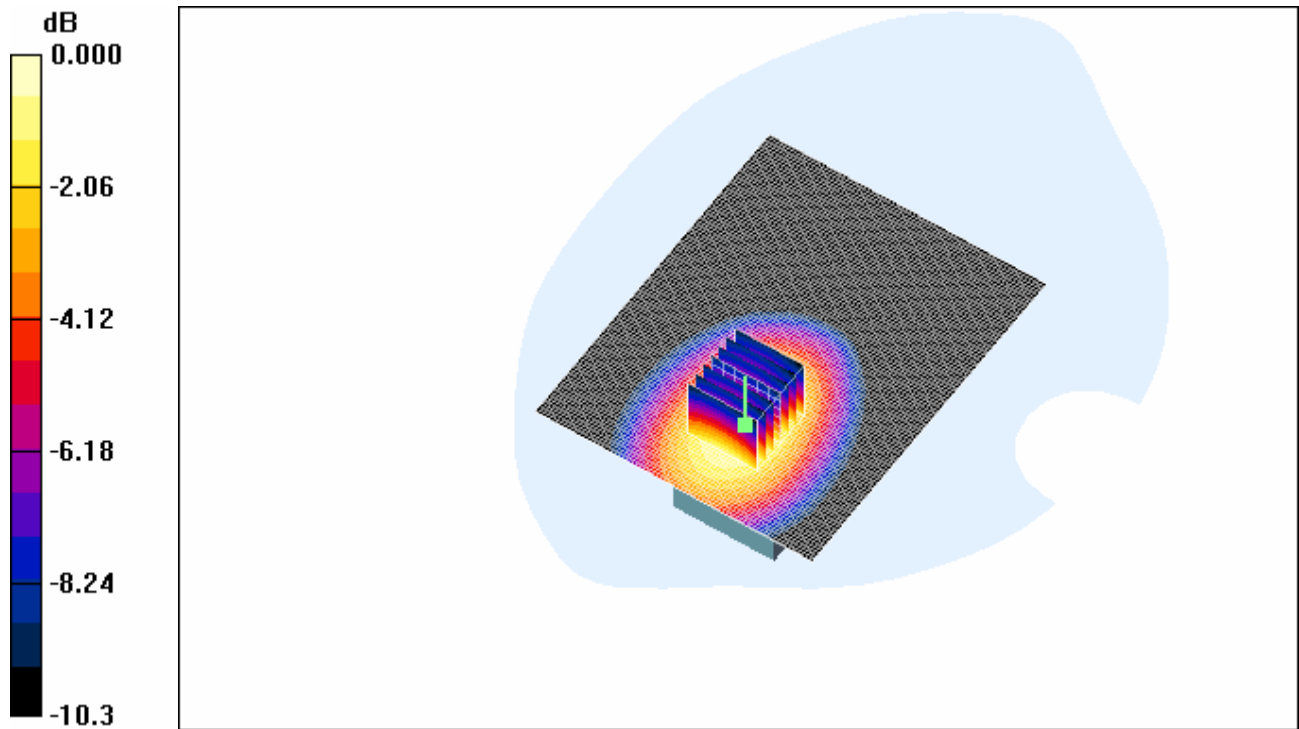

0 dB = 0.929mW/g

#### 4.30 GSM850- Flat Phantom- Head -Low- BYD

Date/Time: 2008-7-25 11:45:14

Test Laboratory: SGS-GSM

GSM850-Head-Worn-Low-BYD-0.5cm

DUT: KJ006AA02; Type: Head; Serial: 20080725

Communication System: GSM850-GSM Mode; Frequency: 824.2 MHz; Duty Cycle: 1:8.3

Medium: HSL 850\_Body Medium parameters used:  $f = 824.2$  MHz;  $\sigma = 0.964$  mho/m;  $\epsilon_r = 53.2$ ;  $\rho = 1000$  kg/m<sup>3</sup>

Phantom section: Flat Section

DASY4 Configuration:

- Probe: ES3DV3 - SN3088; ConvF(5.81, 5.81, 5.81); Calibrated: 2008-1-18

- Sensor-Surface: 4mm (Mechanical Surface Detection)
- Electronics: DAE3 Sn569; Calibrated: 2007-11-19
- Phantom: SAM 12; Type: SAM V4.0; Serial: TP-1283
- Measurement SW: DASY4, V4.7 Build 44; Postprocessing SW: SEMCAD, V1.8 Build 171

Body Worn - Low BYD/Area Scan (81x101x1): Measurement grid: dx=15mm, dy=15mm  
Maximum value of SAR (interpolated) = 0.645 mW/g

Body Worn - Low BYD/Zoom Scan (7x7x7) (7x7x7)/Cube 0: Measurement grid: dx=5mm, dy=5mm, dz=5mm

Reference Value = 5.42 V/m; Power Drift = 0.206 dB

Peak SAR (extrapolated) = 0.859 W/kg

SAR(1 g) = 0.610 mW/g; SAR(10 g) = 0.416 mW/g

Maximum value of SAR (measured) = 0.648 mW/g

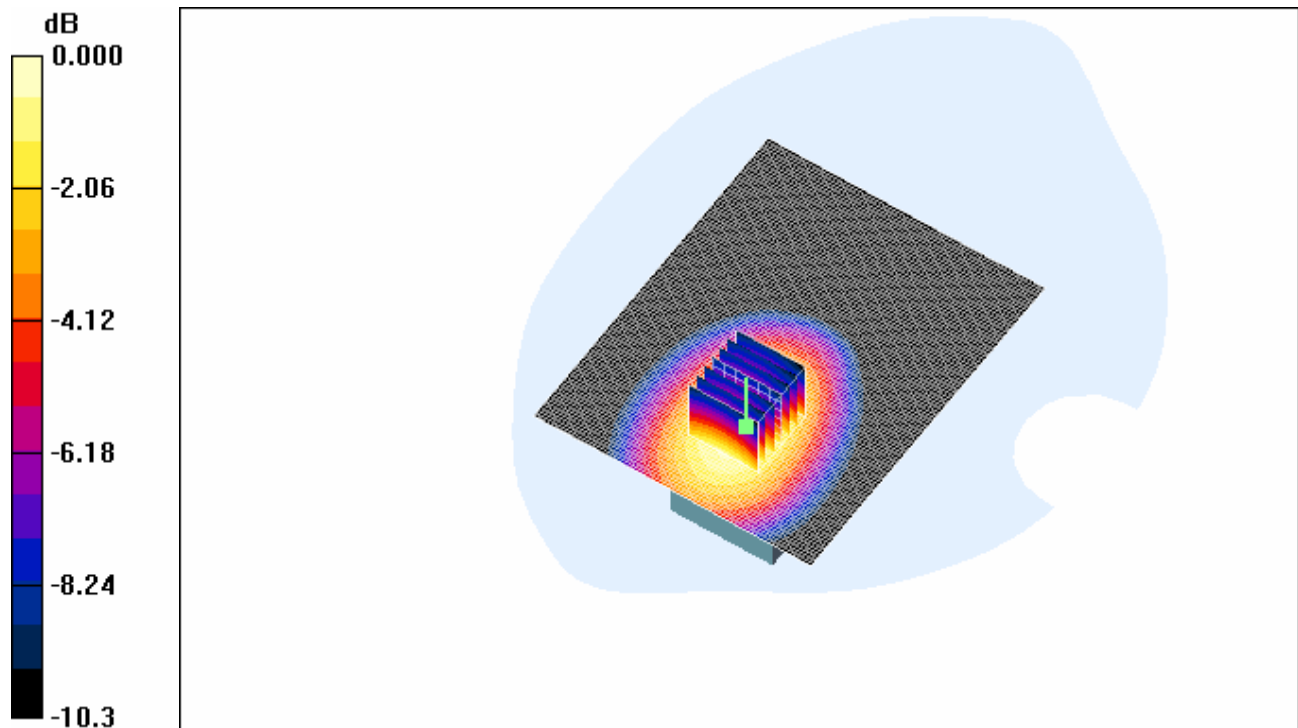

0 dB = 0.648mW/g



#### **4.31 GSM850- Flat Phantom- Head -High- BYD**

Date/Time: 2008-7-25 12:26:04

Test Laboratory: SGS-GSM

GSM850-Head-Worn-High-BYD-0.5cm

DUT: KJ006AA02; Type: Head; Serial: 20080725

Communication System: GSM850-GSM Mode; Frequency: 848.8 MHz; Duty Cycle: 1:8.3

Medium: HSL 850\_Body Medium parameters used:  $f = 848.8$  MHz;  $\sigma = 0.994$  mho/m;  $\epsilon_r = 53.1$ ;  $\rho = 1000$  kg/m<sup>3</sup>

Phantom section: Flat Section

DASY4 Configuration:

- Probe: ES3DV3 - SN3088; ConvF(5.81, 5.81, 5.81); Calibrated: 2008-1-18
- Sensor-Surface: 4mm (Mechanical Surface Detection)
- Electronics: DAE3 Sn569; Calibrated: 2007-11-19
- Phantom: SAM 12; Type: SAM V4.0; Serial: TP-1283
- Measurement SW: DASY4, V4.7 Build 44; Postprocessing SW: SEMCAD, V1.8 Build 171

Body Worn - High BYD/Area Scan (81x101x1): Measurement grid: dx=15mm, dy=15mm

Maximum value of SAR (interpolated) = 0.752 mW/g

Body Worn - High BYD/Zoom Scan (7x7x7) (7x7x7)/Cube 0: Measurement grid: dx=5mm, dy=5mm, dz=5mm

Reference Value = 5.12 V/m; Power Drift = 0.062 dB

Peak SAR (extrapolated) = 0.976 W/kg

SAR(1 g) = 0.689 mW/g; SAR(10 g) = 0.469 mW/g

Maximum value of SAR (measured) = 0.736 mW/g

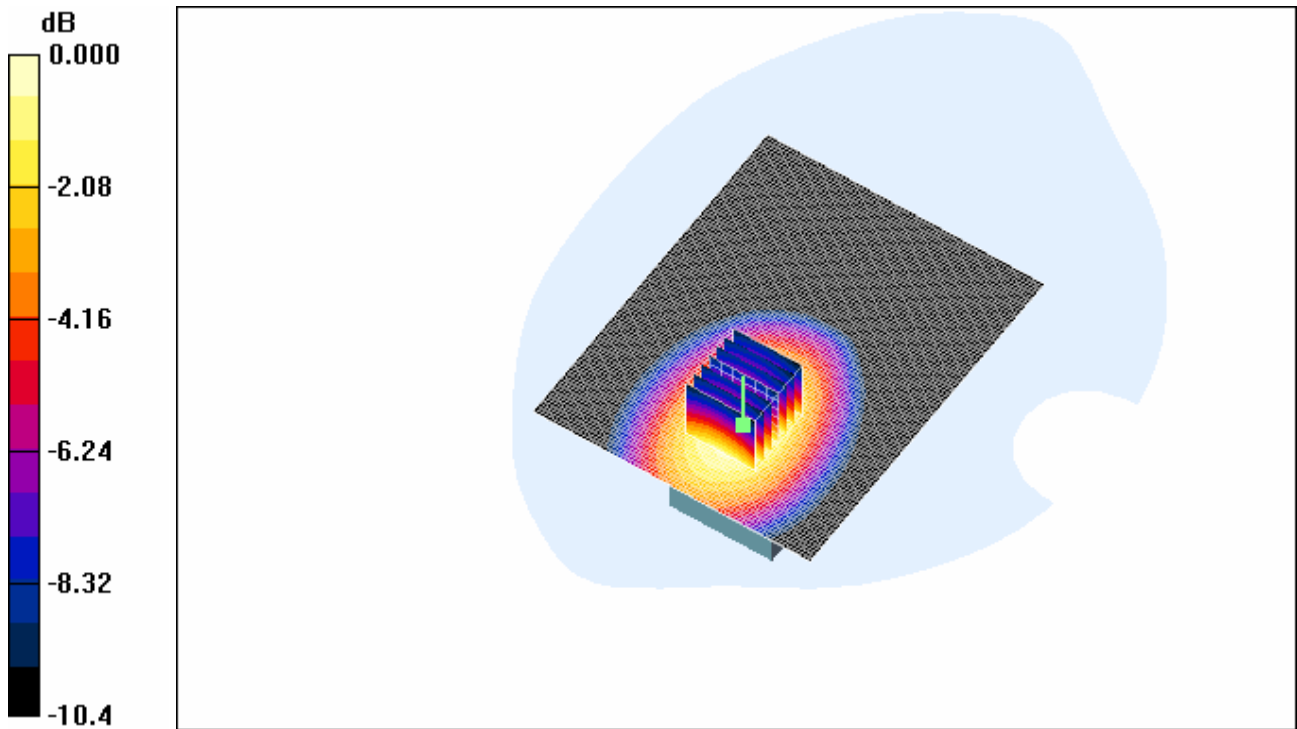

0 dB = 0.736mW/g

#### **4.32 GSM850- Flat Phantom- Head -Mid-Coslight**

Date/Time: 2008-7-25 13:19:34

Test Laboratory: SGS-GSM

GSM850-Head-Worn-Mid-Cos-0.5cm

DUT: KJ006AA02; Type: Head; Serial: 20080725

Communication System: GSM850-GSM Mode; Frequency: 848.8 MHz; Duty Cycle: 1:8.3

Medium: HSL 850\_Body Medium parameters used:  $f = 848.8$  MHz;  $\sigma = 0.994$  mho/m;  $\epsilon_r = 53.1$ ;  $\rho = 1000$  kg/m<sup>3</sup>

Phantom section: Flat Section

DASY4 Configuration:

- Probe: ES3DV3 - SN3088; ConvF(5.81, 5.81, 5.81); Calibrated: 2008-1-18

- Sensor-Surface: 4mm (Mechanical Surface Detection)
- Electronics: DAE3 Sn569; Calibrated: 2007-11-19
- Phantom: SAM 12; Type: SAM V4.0; Serial: TP-1283
- Measurement SW: DASY4, V4.7 Build 44; Postprocessing SW: SEMCAD, V1.8 Build 171

Body Worn - Mid Coslight/Area Scan (81x101x1): Measurement grid: dx=15mm, dy=15mm  
Maximum value of SAR (interpolated) = 0.888 mW/g

Body Worn - Mid Coslight/Zoom Scan (7x7x7) (7x7x7)/Cube 0: Measurement grid: dx=5mm, dy=5mm, dz=5mm

Reference Value = 4.60 V/m; Power Drift = 0.008 dB

Peak SAR (extrapolated) = 1.18 W/kg

SAR(1 g) = 0.860 mW/g; SAR(10 g) = 0.588 mW/g

Maximum value of SAR (measured) = 0.921 mW/g

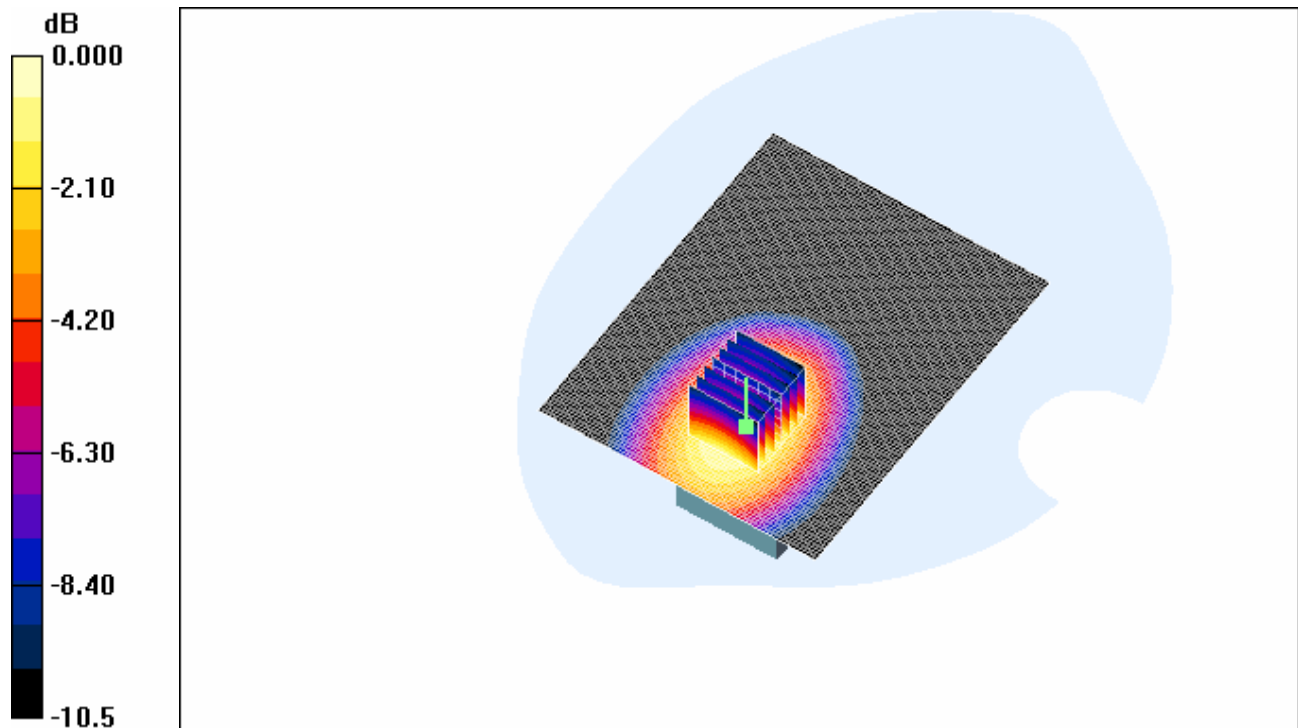

0 dB = 0.921mW/g

### **4.33 PCS1900- Flat Phantom- Head -Middle- BYD**

Date/Time: 2008-7-24 18:24:54

Test Laboratory: SGS-GSM

PCS1900Head-Worn-Mid-BYD-0.5cm

DUT: KJ006AA02; Type: Head; Serial: 20080725

Communication System: PCS1900-GSM Mode; Frequency: 1880 MHz; Duty Cycle: 1:8.3

Medium: 1900-Head Medium parameters used:  $f = 1880$  MHz;  $\sigma = 1.37$  mho/m;  $\epsilon_r = 41.8$ ;  $\rho = 1000$  kg/m<sup>3</sup>

Phantom section: Flat Section

DASY4 Configuration:

- Probe: ES3DV3 - SN3088; ConvF(4.84, 4.84, 4.84); Calibrated: 2008-1-18
- Sensor-Surface: 4mm (Mechanical Surface Detection)
- Electronics: DAE3 Sn569; Calibrated: 2007-11-19
- Phantom: SAM 12; Type: SAM V4.0; Serial: TP-1283
- Measurement SW: DASY4, V4.7 Build 44; Postprocessing SW: SEMCAD, V1.8 Build 171

Body Worn - Middle BYD/Area Scan (81x131x1): Measurement grid: dx=15mm, dy=15mm

Maximum value of SAR (interpolated) = 0.359 mW/g

Body Worn - Middle BYD/Zoom Scan (7x7x7)/Cube 0: Measurement grid: dx=5mm, dy=5mm, dz=5mm

Reference Value = 5.48 V/m; Power Drift = 0.019 dB

Peak SAR (extrapolated) = 0.569 W/kg

SAR(1 g) = 0.324 mW/g; SAR(10 g) = 0.173 mW/g

Maximum value of SAR (measured) = 0.361 mW/g

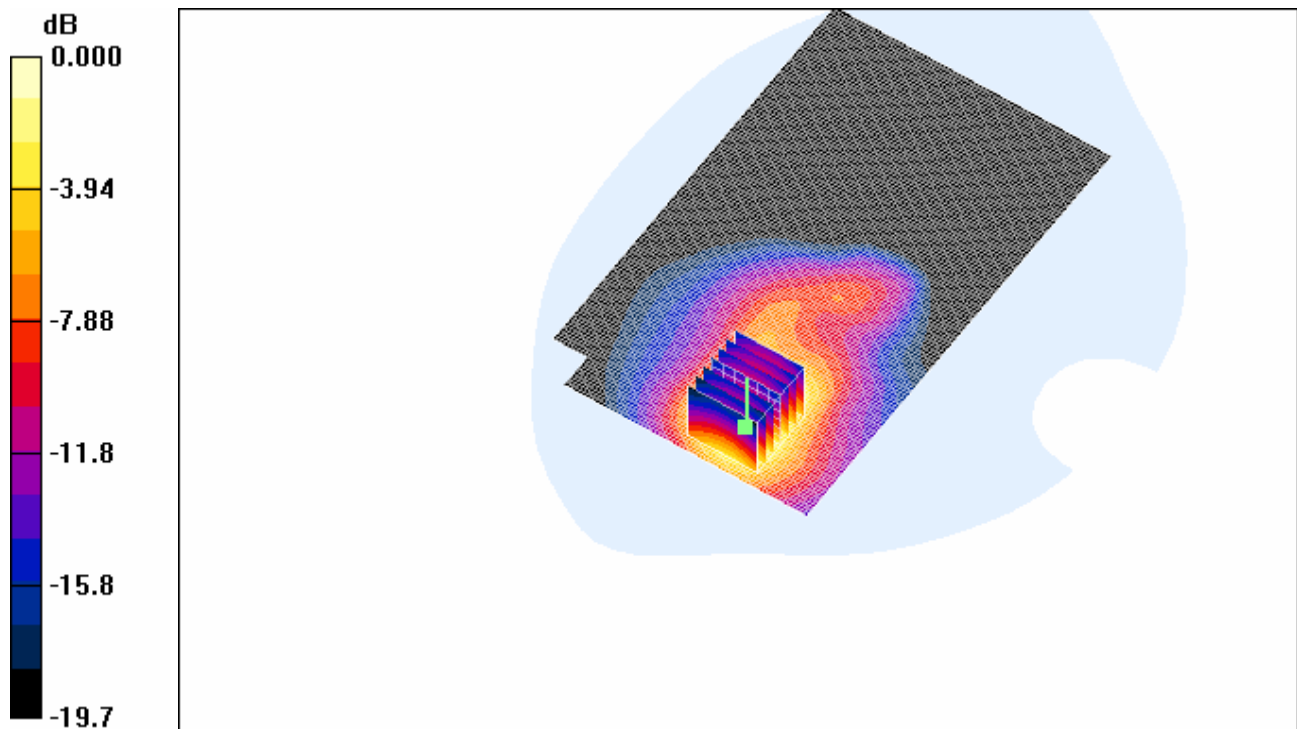

0 dB = 0.361mW/g

#### 4.34 PCS1900- Flat Phantom- Head -Low- BYD

Date/Time: 2008-7-24 19:48:52

Test Laboratory: SGS-GSM

PCS1900Head-Worn-Low-BYD-0.5cm

DUT: KJ006AA02; Type: Head; Serial: 20080725

Communication System: PCS1900-GSM Mode; Frequency: 1850.2 MHz;Duty Cycle: 1:8.3

Medium: 1900-Head Medium parameters used:  $f = 1850.2$  MHz;  $\sigma = 1.34$  mho/m;  $\epsilon_r = 41.5$ ;  $\rho = 1000$  kg/m<sup>3</sup>

Phantom section: Flat Section

DASY4 Configuration:

- Probe: ES3DV3 - SN3088; ConvF(4.84, 4.84, 4.84); Calibrated: 2008-1-18

- Sensor-Surface: 4mm (Mechanical Surface Detection)
- Electronics: DAE3 Sn569; Calibrated: 2007-11-19
- Phantom: SAM 12; Type: SAM V4.0; Serial: TP-1283
- Measurement SW: DASY4, V4.7 Build 44; Postprocessing SW: SEMCAD, V1.8 Build 171

Body Worn - Low BYD 3/Area Scan (81x131x1): Measurement grid: dx=15mm, dy=15mm  
Maximum value of SAR (interpolated) = 0.530 mW/g

Body Worn - Low BYD 3/Zoom Scan (7x7x7)/Cube 0: Measurement grid: dx=5mm, dy=5mm,  
dz=5mm

Reference Value = 3.59 V/m; Power Drift = -0.089 dB

Peak SAR (extrapolated) = 0.788 W/kg

SAR(1 g) = 0.448 mW/g; SAR(10 g) = 0.243 mW/g

Maximum value of SAR (measured) = 0.497 mW/g

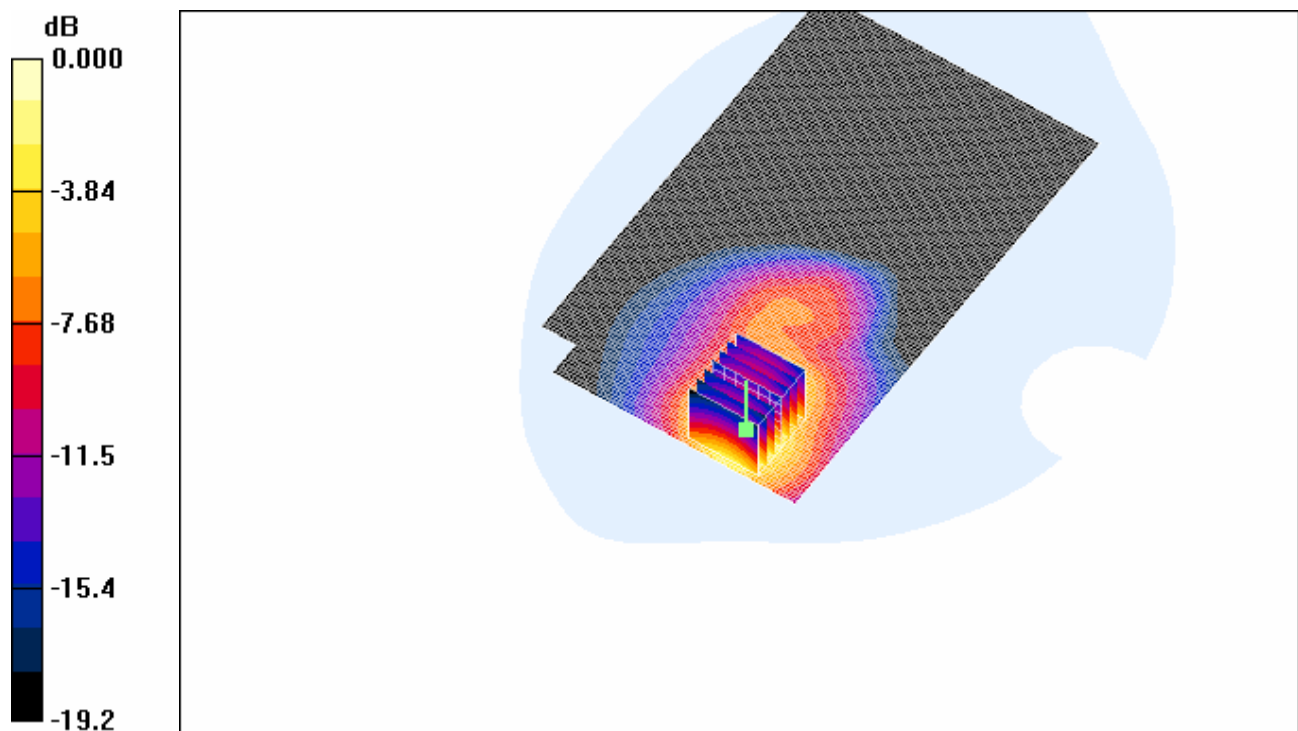

0 dB = 0.497mW/g

#### **4.35 PCS1900- Flat Phantom- Head -High- BYD**

Date/Time: 2008-7-24 20:29:40

Test Laboratory: SGS-GSM

PCS1900Head-Worn-High-BYD-0.5cm

DUT: KJ006AA02; Type: Head; Serial: 20080725

Communication System: PCS1900-GSM Mode; Frequency: 1909.8 MHz; Duty Cycle: 1:8.3

Medium: 1900-Head Medium parameters used:  $f = 1909.8$  MHz;  $\sigma = 1.39$  mho/m;  $\epsilon_r = 41.1$ ;  $\rho = 1000$  kg/m<sup>3</sup>

Phantom section: Flat Section

DASY4 Configuration:

- Probe: ES3DV3 - SN3088; ConvF(4.84, 4.84, 4.84); Calibrated: 2008-1-18
- Sensor-Surface: 4mm (Mechanical Surface Detection)
- Electronics: DAE3 Sn569; Calibrated: 2007-11-19
- Phantom: SAM 12; Type: SAM V4.0; Serial: TP-1283
- Measurement SW: DASY4, V4.7 Build 44; Postprocessing SW: SEMCAD, V1.8 Build 171

Body Worn -High BYD/Area Scan (81x131x1): Measurement grid: dx=15mm, dy=15mm

Maximum value of SAR (interpolated) = 0.357 mW/g

Body Worn -High BYD/Zoom Scan (7x7x7)/Cube 0: Measurement grid: dx=5mm, dy=5mm, dz=5mm

Reference Value = 4.62 V/m; Power Drift = -0.091 dB

Peak SAR (extrapolated) = 0.549 W/kg

SAR(1 g) = 0.307 mW/g; SAR(10 g) = 0.159 mW/g

Maximum value of SAR (measured) = 0.340 mW/g

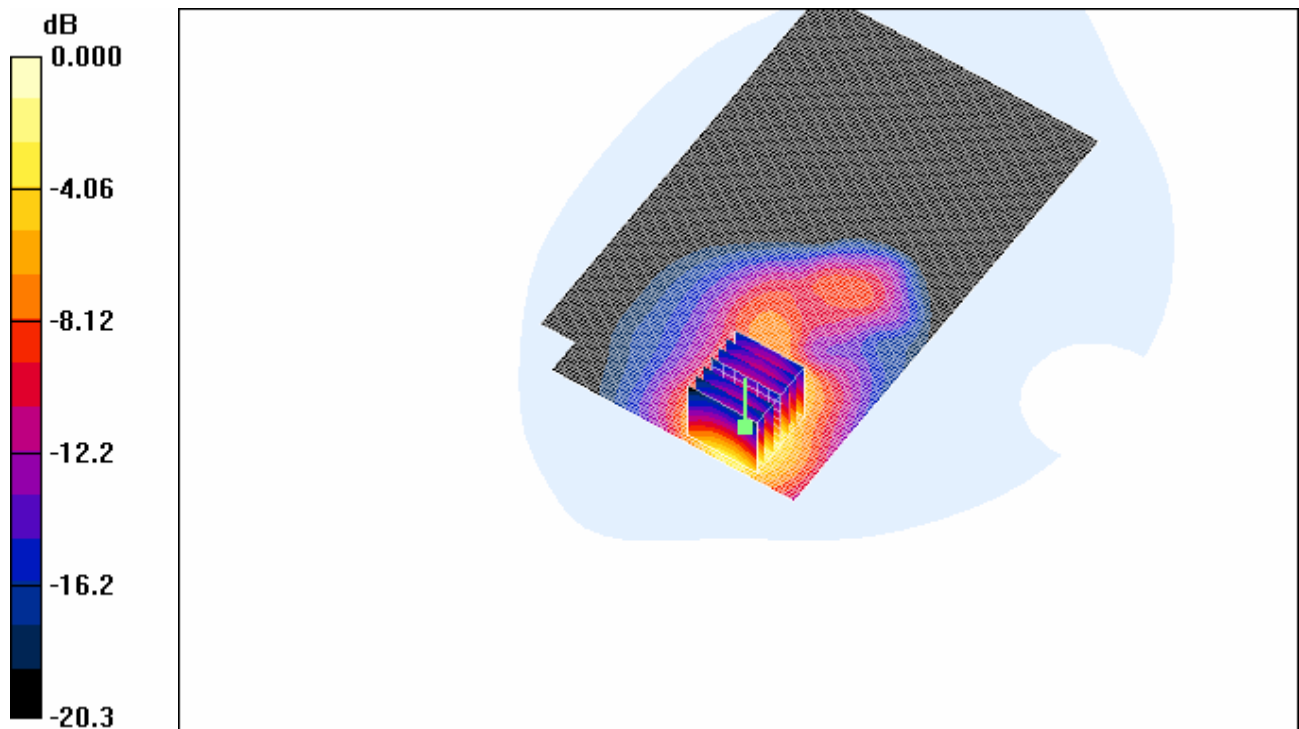

0 dB = 0.340mW/g

#### 4.36 PCS1900- Flat Phantom- Head -Low-Coslight

Date/Time: 2008-7-24 17:56:43

Test Laboratory: SGS-GSM

PCS1900Head-Worn-Low-Cos-0.5cm

DUT: KJ006AA02; Type: Head; Serial: 20080725

Communication System: PCS1900-GSM Mode; Frequency: 1850.2 MHz;Duty Cycle: 1:8.3

Medium: 1900-Head Medium parameters used:  $f = 1850.2$  MHz;  $\sigma = 1.34$  mho/m;  $\epsilon_r = 41.5$ ;  $\rho = 1000$  kg/m<sup>3</sup>

Phantom section: Flat Section

DASY4 Configuration:

- Probe: ES3DV3 - SN3088; ConvF(4.84, 4.84, 4.84); Calibrated: 2008-1-18



- Sensor-Surface: 4mm (Mechanical Surface Detection)
- Electronics: DAE3 Sn569; Calibrated: 2007-11-19
- Phantom: SAM 12; Type: SAM V4.0; Serial: TP-1283
- Measurement SW: DASY4, V4.7 Build 44; Postprocessing SW: SEMCAD, V1.8 Build 171

Body Worn - Low Coslight/Area Scan (81x131x1): Measurement grid: dx=15mm, dy=15mm

Maximum value of SAR (interpolated) = 0.486 mW/g

Body Worn - Low Coslight/Zoom Scan (7x7x7)/Cube 0: Measurement grid: dx=5mm, dy=5mm, dz=5mm

Reference Value = 6.99 V/m; Power Drift = -0.044 dB

Peak SAR (extrapolated) = 0.722 W/kg

SAR(1 g) = 0.417 mW/g; SAR(10 g) = 0.228 mW/g

Maximum value of SAR (measured) = 0.460 mW/g

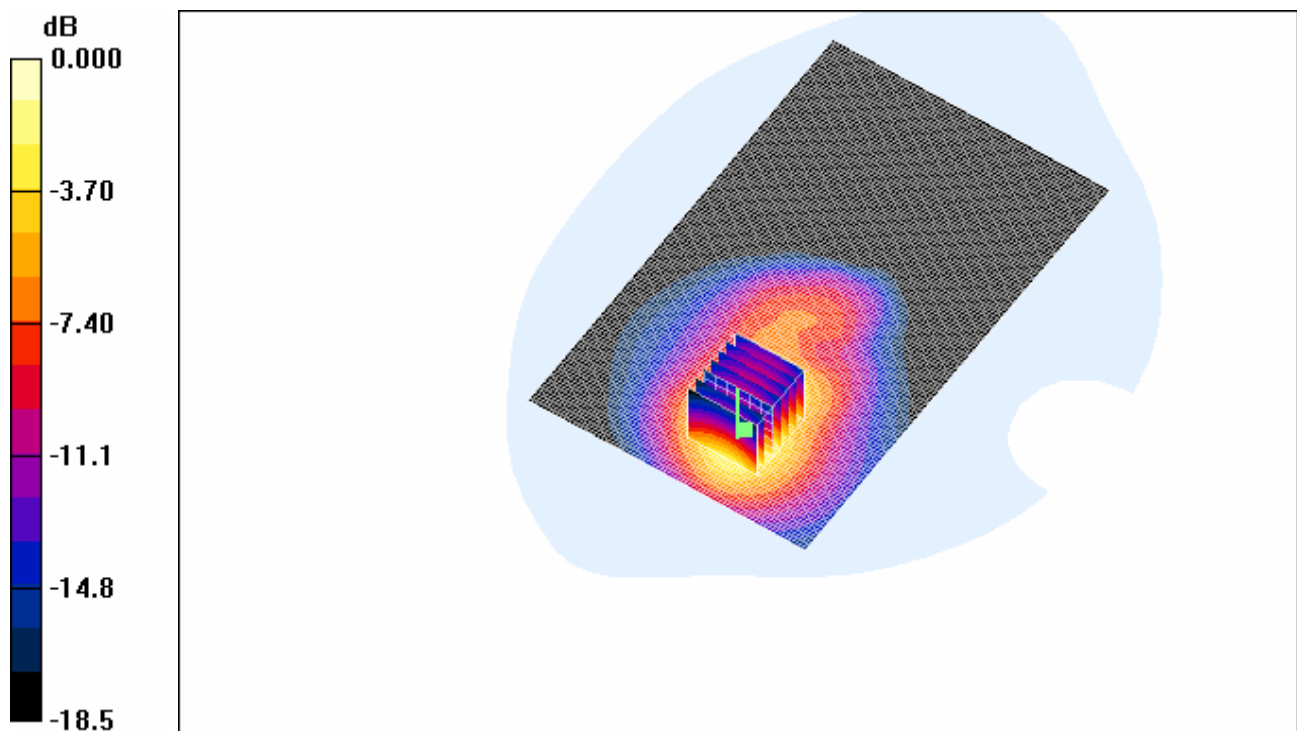

0 dB = 0.460mW/g

## Appendix

### 1. Photographs of Test Setup

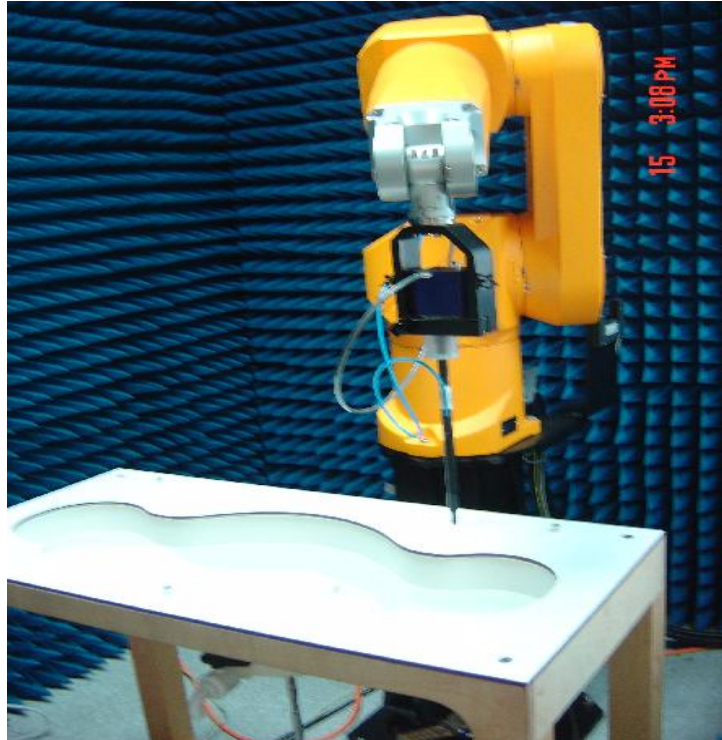

Fig.1 Photograph of the SAR measurement System

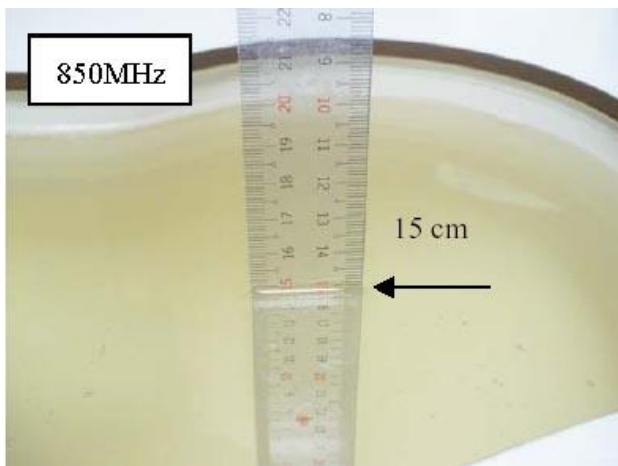

Fig.2 Photograph of the Tissue Simulant Fluid Liquid depth 15cm for Left-Head Side

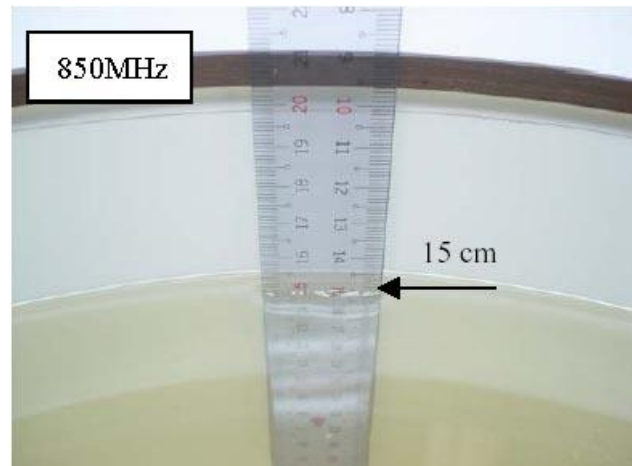

Fig.3 Photograph of the Tissue Simulant Liquid depth 15cm for Body-Worn

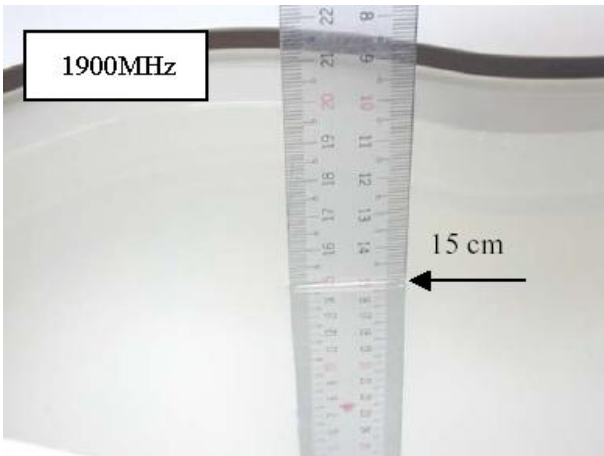

Fig.4 Photograph of the Tissue Simulant Fluid Liquid depth 15cm for Right-Head Side

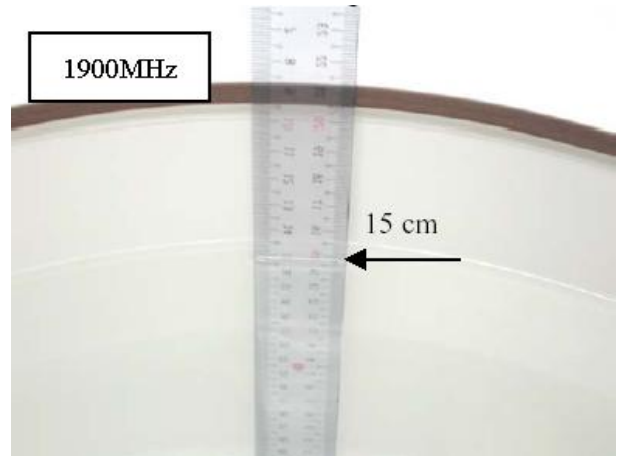

Fig.5 Photograph of the Tissue Simulant Liquid depth 15cm for Body-Worn



Fig.6 Photograph of the Left Hand Side Cheek status

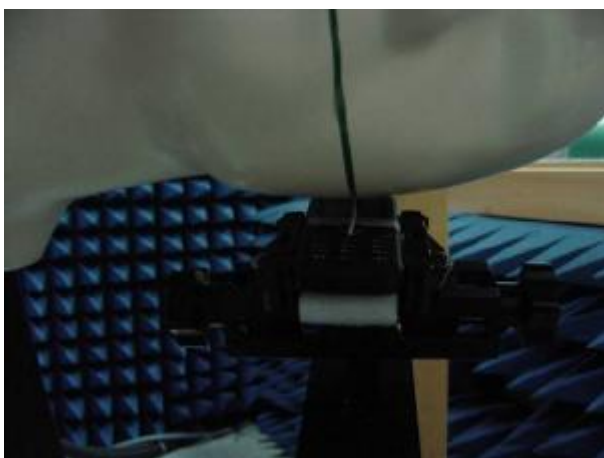
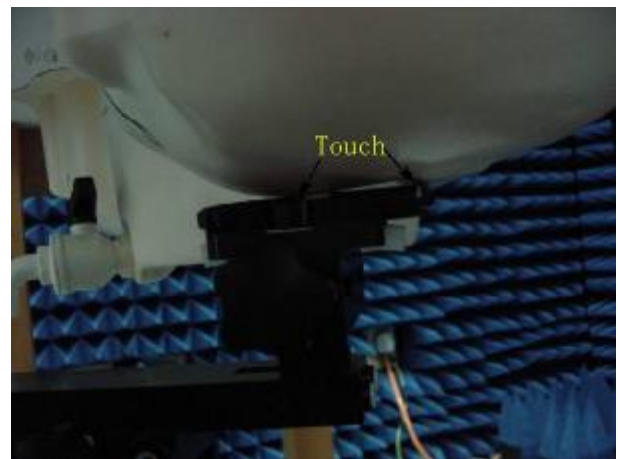
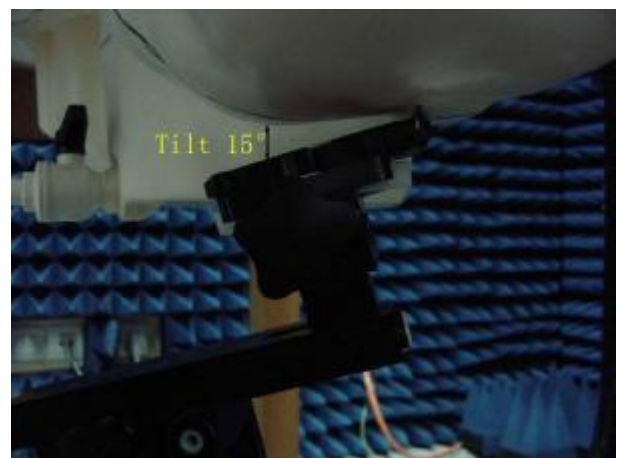

Fig.7 Photograph of the Left Hand Side Tilt status



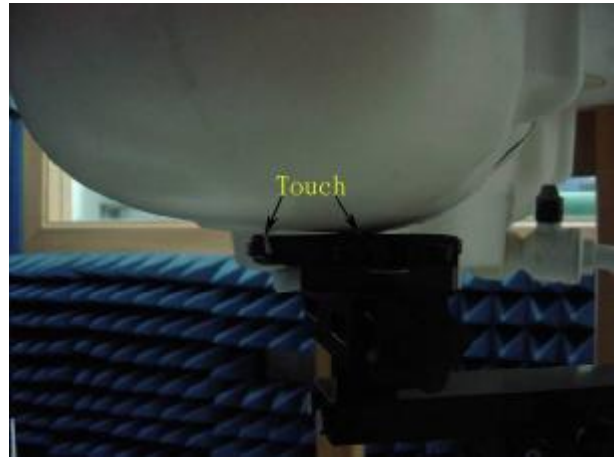
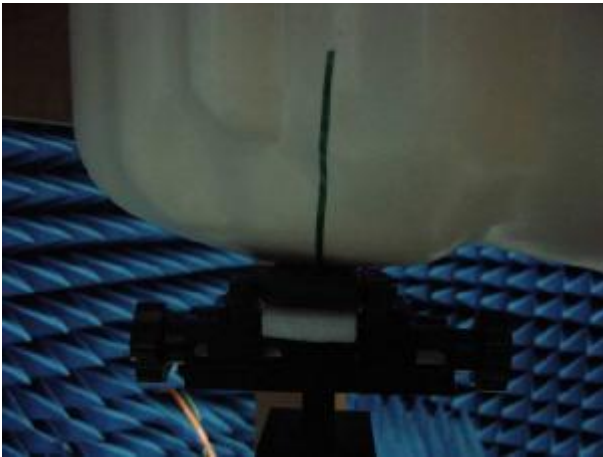

Fig.8 Photograph of the Right Hand Side Cheek status

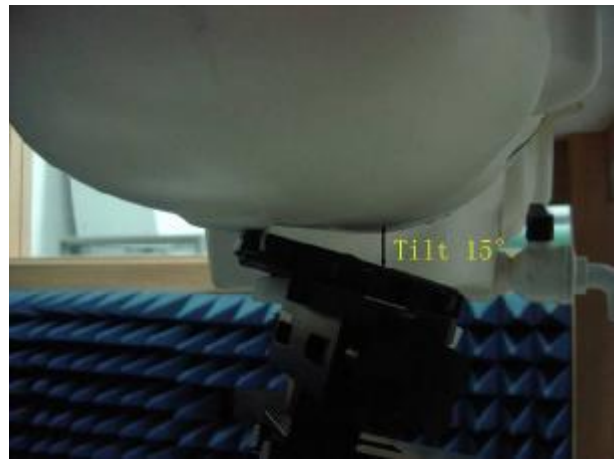
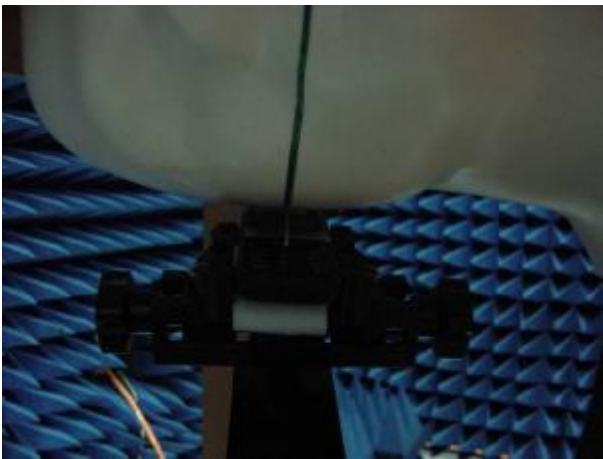

Fig.9 Photograph of the Right Hand Side Tilt status

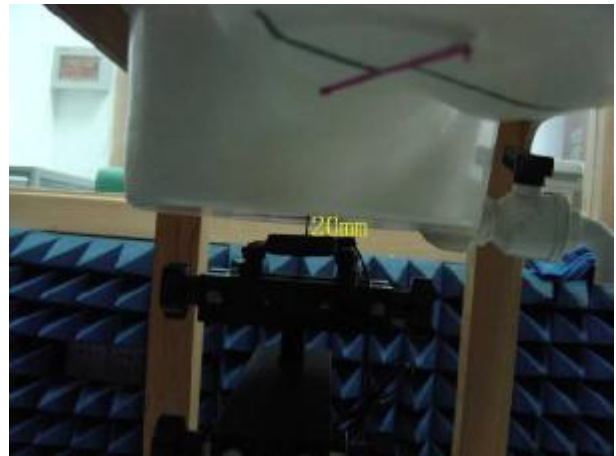

Fig.10 Photograph of the BodyWorn status



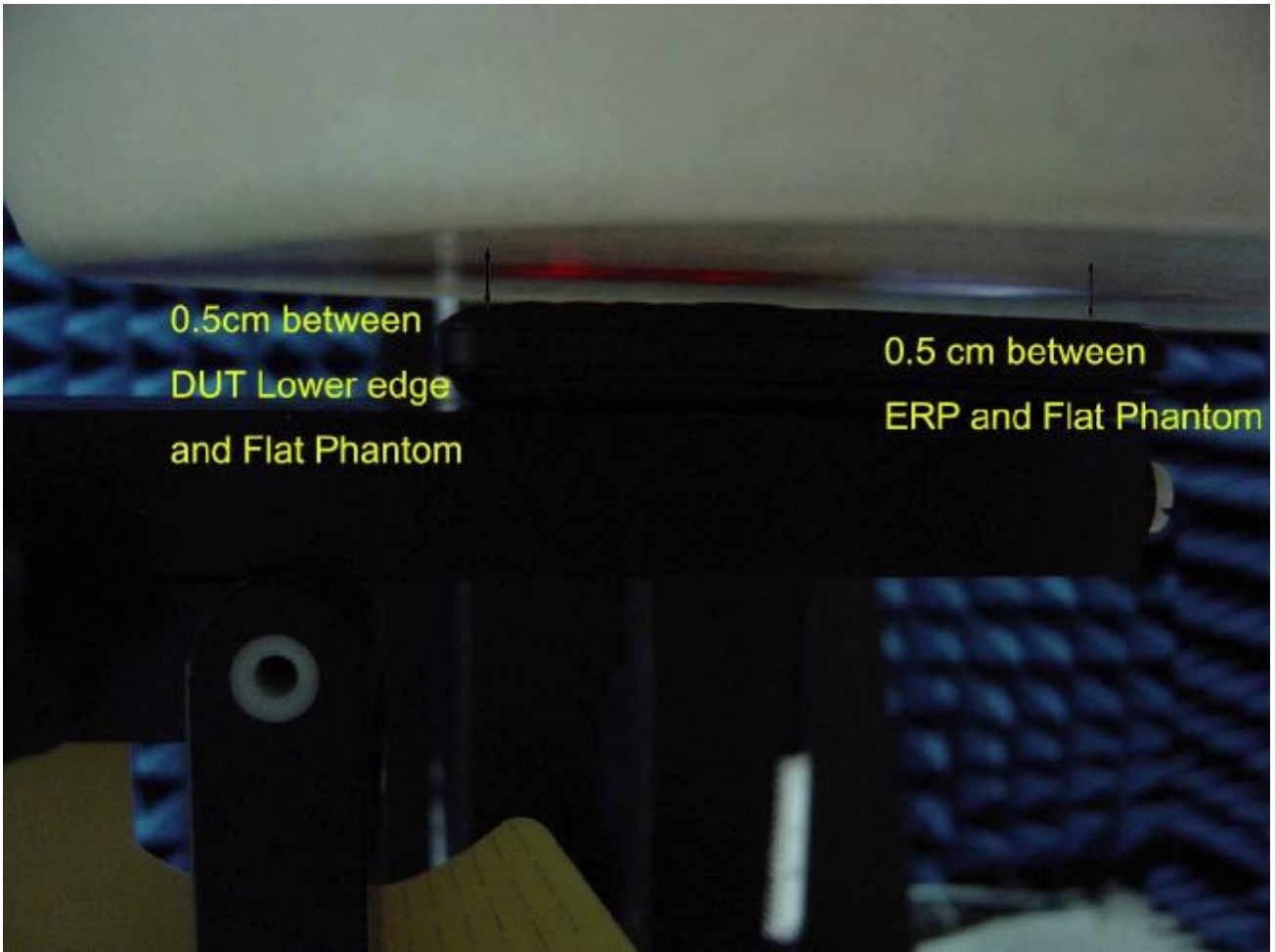

Fig.11 Photograph of the Flat Phantom status

**2. Photographs of the EUT**



Fig.12 Front View



Fig.13 Back View

### 3. Photographs of the battery



Fig. 14 Battery For CAB2001010C1

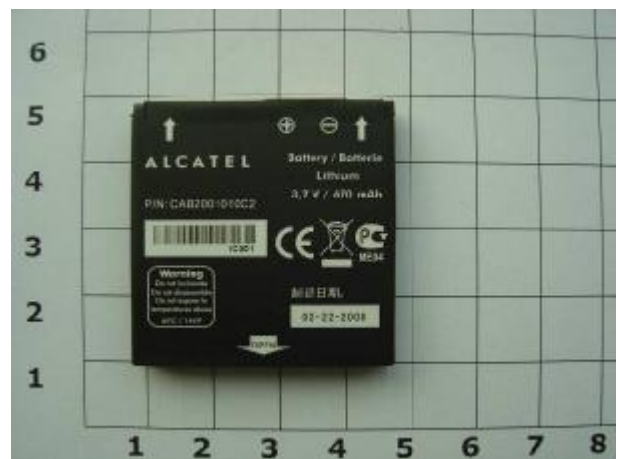

Fig. 15 Battery For CAB2001010C2

**4. Photograph of the charger and Headset**



Fig.16 Charger



Fig17 Headset



**5. Probe Calibration certificate**

**Calibration Laboratory of  
 Schmid & Partner  
 Engineering AG**  
 Zeughausstrasse 43, 8004 Zurich, Switzerland



**S** Schweizerischer Kalibrierdienst  
**S** Service suisse d'étalonnage  
**C** Servizio svizzero di taratura  
**S** Swiss Calibration Service

Accredited by the Swiss Accreditation Service (SAS)  
 The Swiss Accreditation Service is one of the signatories to the EA  
 Multilateral Agreement for the recognition of calibration certificates

Accreditation No.: **SCS 108**

Client **SGS China (Auden)**

Certificate No: **ES3-3088\_Jan08**

**CALIBRATION CERTIFICATE**

Object **ES3DV3 - SN:3088**

Calibration procedure(s) **QA CAL-01.v6  
 Calibration procedure for dosimetric E-field probes**

Calibration date: **January 18, 2008**

Condition of the calibrated item **In Tolerance**

This calibration certificate documents the traceability to national standards, which realize the physical units of measurements (SI).  
 The measurements and the uncertainties with confidence probability are given on the following pages and are part of the certificate.  
 All calibrations have been conducted in the closed laboratory facility: environment temperature (22 ± 3)°C and humidity < 70%.

Calibration Equipment used (M&TE critical for calibration)

Primary Standards	ID #	Cal Date (Calibrated by, Certificate No.)	Scheduled Calibration
Power meter E4419B	GB41293874	29-Mar-07 (METAS, No. 217-00670)	Mar-08
Power sensor E4412A	MY41495277	29-Mar-07 (METAS, No. 217-00670)	Mar-08
Power sensor E4412A	MY41498087	29-Mar-07 (METAS, No. 217-00670)	Mar-08
Reference 3 dB Attenuator	SN: S5054 (3c)	8-Aug-07 (METAS, No. 217-00719)	Aug-08
Reference 20 dB Attenuator	SN: S5086 (20b)	29-Mar-07 (METAS, No. 217-00671)	Mar-08
Reference 30 dB Attenuator	SN: S5129 (30b)	8-Aug-07 (METAS, No. 217-00720)	Aug-08
Reference Probe ES3DV2	SN: 3013	2-Jan-08 (SPEAG, No. ES3-3013_Jan08)	Jan-09
DAE4	SN: 054	20-Apr-07 (SPEAG, Nn. DAE4-654_Apr07)	Apr-08

Secondary Standards	ID #	Check Date (in house)	Scheduled Check
RF generator HP 8648C	US3642J01700	4-Aug-99 (SPEAG, in house check Oct-07)	In house check: Oct-09
Network Analyzer HP 8753E	US37360685	16-Oct-01 (SPEAG, in house check Oct-07)	In house check: Oct-08

	Name	Function	Signature
Calibrated by:	Katja Pokovic	Technical Manager	
Approved by:	Niels Kuster	Quality Manager	

Issued: January 18, 2008

This calibration certificate shall not be reproduced except in full without written approval of the laboratory.

**Calibration Laboratory of**  
Schmid & Partner  
Engineering AG  
Zeughausstrasse 43, 8004 Zurich, Switzerland



**S** Schweizerischer Kalibrierdienst  
**C** Service suisse d'étalonnage  
**S** Servizio svizzero di taratura  
**S** Swiss Calibration Service

Accredited by the Swiss Accreditation Service (SAS)  
The Swiss Accreditation Service is one of the signatories to the EA  
Multilateral Agreement for the recognition of calibration certificates

Accreditation No.: SCS 108

#### Glossary:

TSL	tissue simulating liquid
NORM <sub>x,y,z</sub>	sensitivity in free space
ConF	sensitivity in TSL / NORM <sub>x,y,z</sub>
DCP	diode compression point
Polarization $\varphi$	$\varphi$ rotation around probe axis
Polarization $\vartheta$	$\vartheta$ rotation around an axis that is in the plane normal to probe axis (at measurement center), i.e., $\vartheta = 0$ is normal to probe axis

#### Calibration is Performed According to the Following Standards:

- IEEE Std 1528-2003, "IEEE Recommended Practice for Determining the Peak Spatial-Averaged Specific Absorption Rate (SAR) in the Human Head from Wireless Communications Devices: Measurement Techniques", December 2003
- IEC 62209-1, "Procedure to measure the Specific Absorption Rate (SAR) for hand-held devices used in close proximity to the ear (frequency range of 300 MHz to 3 GHz)", February 2005

#### Methods Applied and Interpretation of Parameters:

- NORM<sub>x,y,z</sub>**: Assessed for E-field polarization  $\vartheta = 0$  ( $f \leq 900$  MHz in TEM-cell;  $f > 1800$  MHz: R22 waveguide). NORM<sub>x,y,z</sub> are only intermediate values, i.e., the uncertainties of NORM<sub>x,y,z</sub> does not effect the E<sup>2</sup>-field uncertainty inside TSL (see below *ConvF*).
- NORM(f)<sub>x,y,z</sub>** = NORM<sub>x,y,z</sub> \* *frequency\_response* (see Frequency Response Chart). This linearization is implemented in DASY4 software versions later than 4.2. The uncertainty of the frequency response is included in the stated uncertainty of *ConvF*.
- DCP<sub>x,y,z</sub>**: DCP are numerical linearization parameters assessed based on the data of power sweep (no uncertainty required). DCP does not depend on frequency nor media.
- ConvF and Boundary Effect Parameters**: Assessed in flat phantom using E-field (or Temperature Transfer Standard for  $f \leq 800$  MHz) and inside waveguide using analytical field distributions based on power measurements for  $f > 800$  MHz. The same setups are used for assessment of the parameters applied for boundary compensation (alpha, depth) of which typical uncertainty values are given. These parameters are used in DASY4 software to improve probe accuracy close to the boundary. The sensitivity in TSL corresponds to NORM<sub>x,y,z</sub> \* *ConvF* whereby the uncertainty corresponds to that given for *ConvF*. A frequency dependent *ConvF* is used in DASY version 4.4 and higher which allows extending the validity from  $\pm 50$  MHz to  $\pm 100$  MHz.
- Spherical isotropy (3D deviation from isotropy)**: in a field of low gradients realized using a flat phantom exposed by a patch antenna.
- Sensor Offset**: The sensor offset corresponds to the offset of virtual measurement center from the probe tip (on probe axis). No tolerance required.

ES3DV3 SN:3088

January 18, 2008

# Probe ES3DV3

## SN:3088

Manufactured:	July 20, 2005
Last calibrated:	December 12, 2006
Recalibrated:	January 18, 2008

Calibrated for DASY Systems

(Note: non-compatible with DASY2 system!)



ES3DV3 SN:3088

January 18, 2008

### Frequency Response of E-Field

(TEM-Cell:ifi110 EXX, Waveguide: R22)

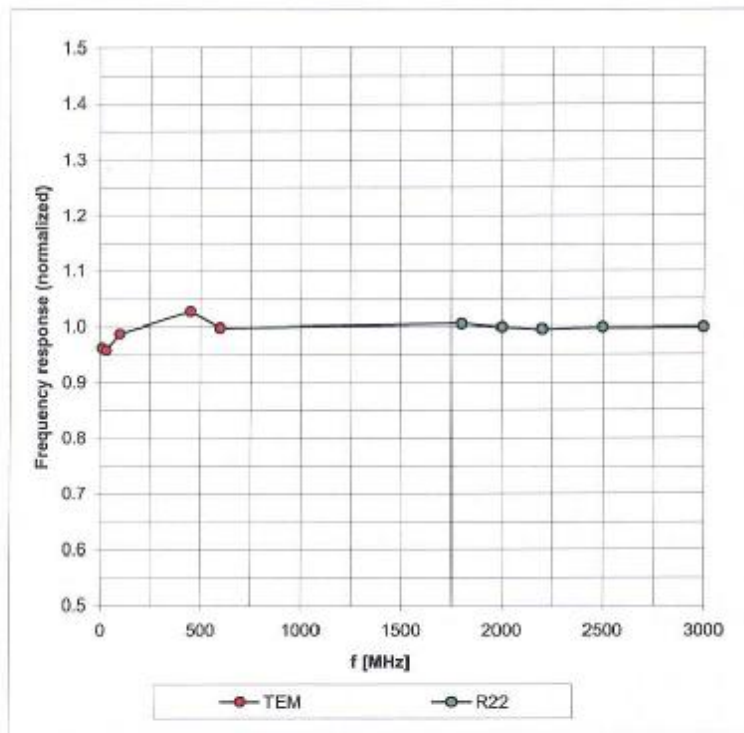

Uncertainty of Frequency Response of E-field:  $\pm 6.3\%$  ( $k=2$ )



ES3DV3 SN:3088

January 18, 2008

### Receiving Pattern ( $\phi$ ), $\vartheta = 0^\circ$

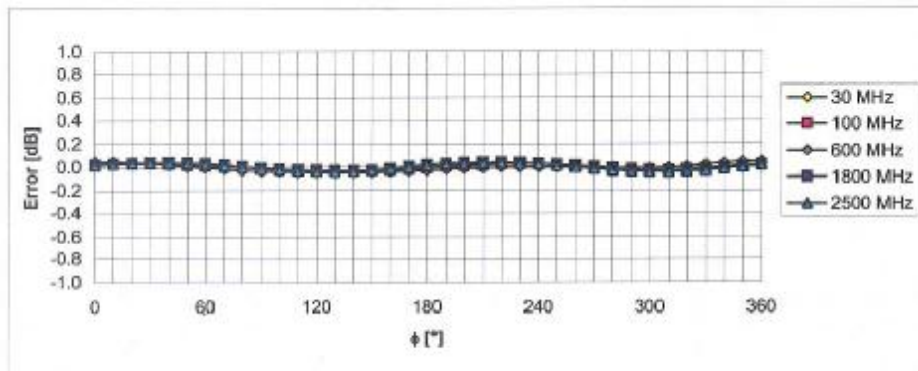
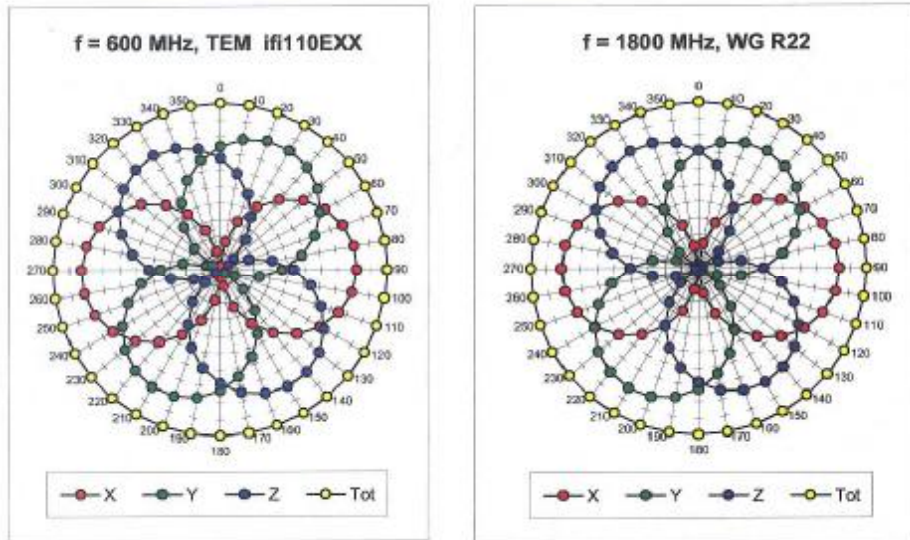

Uncertainty of Axial Isotropy Assessment:  $\pm 0.5\%$  ( $k=2$ )

ES3DV3 SN:3088

January 18, 2008

### Dynamic Range $f(SAR_{head})$ (Waveguide R22, $f = 1800$ MHz)

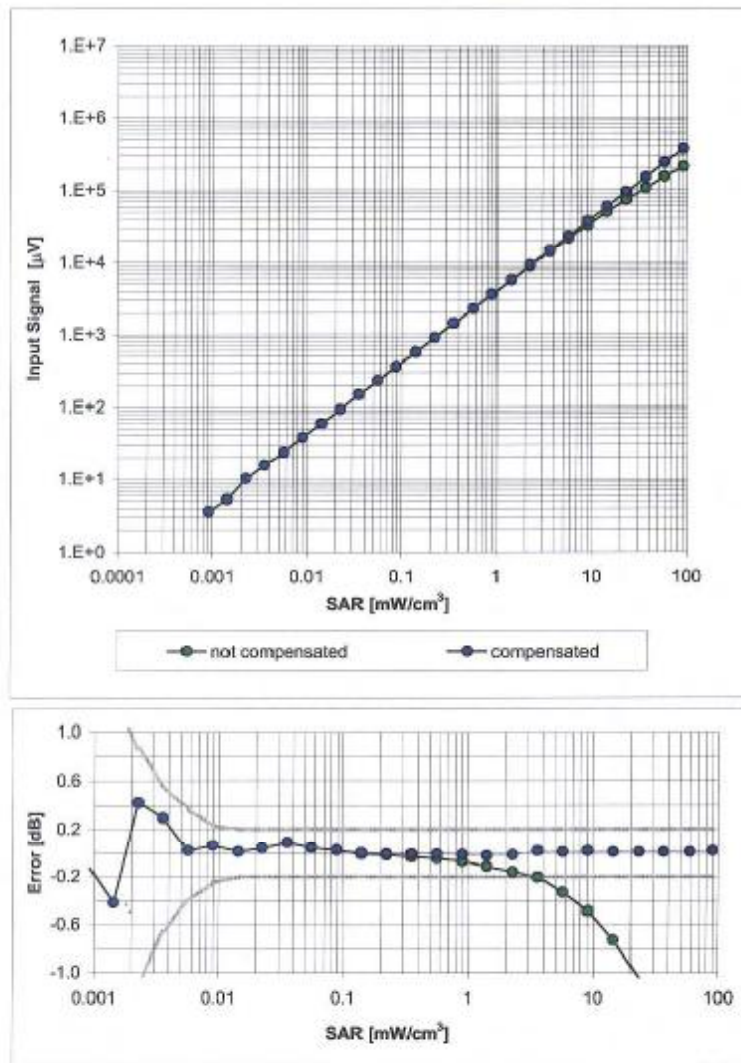

Uncertainty of Linearity Assessment:  $\pm 0.6\%$  ( $k=2$ )

ES3DV3 SN:3088

January 18, 2008

### Conversion Factor Assessment

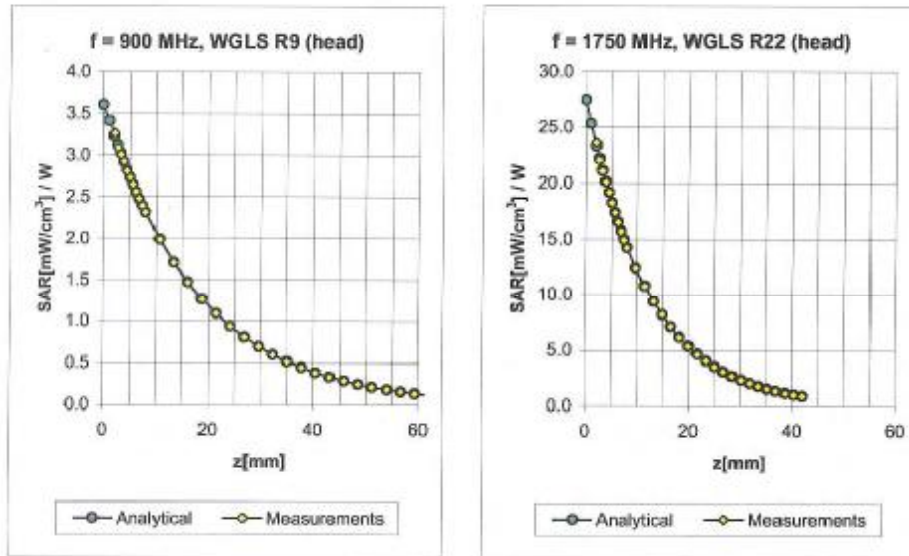

f [MHz]	Validity [MHz] <sup>c</sup>	TSL	Permittivity	Conductivity	Alpha	Depth	ConvF Uncertainty
900	± 50 / ± 100	Head	41.5 ± 5%	0.97 ± 5%	0.90	1.23	6.15 ± 11.0% (k=2)
1750	± 50 / ± 100	Head	40.1 ± 5%	1.37 ± 5%	0.93	1.18	5.04 ± 11.0% (k=2)
1950	± 50 / ± 100	Head	40.0 ± 5%	1.40 ± 5%	0.73	1.35	4.84 ± 11.0% (k=2)
2450	± 50 / ± 100	Head	39.2 ± 5%	1.80 ± 5%	0.70	1.39	4.53 ± 11.8% (k=2)
900	± 50 / ± 100	Body	55.0 ± 5%	1.05 ± 5%	0.95	1.14	5.81 ± 11.0% (k=2)
1750	± 50 / ± 100	Body	53.4 ± 5%	1.49 ± 5%	0.90	1.17	4.92 ± 11.0% (k=2)
1950	± 50 / ± 100	Body	53.3 ± 5%	1.52 ± 5%	0.84	1.23	4.60 ± 11.0% (k=2)
2450	± 50 / ± 100	Body	52.7 ± 5%	1.95 ± 5%	0.84	1.17	4.13 ± 11.8% (k=2)

<sup>c</sup> The validity of ± 100 MHz only applies for DASY v4.4 and higher (see Page 2). The uncertainty is the RSS of the ConvF uncertainty at calibration frequency and the uncertainty for the indicated frequency band.



ES3DV3 SN:3088

January 18, 2008

### Deviation from Isotropy in HSL\*\* Error ( $\phi$ , $\theta$ ), $f = 900$ MHz

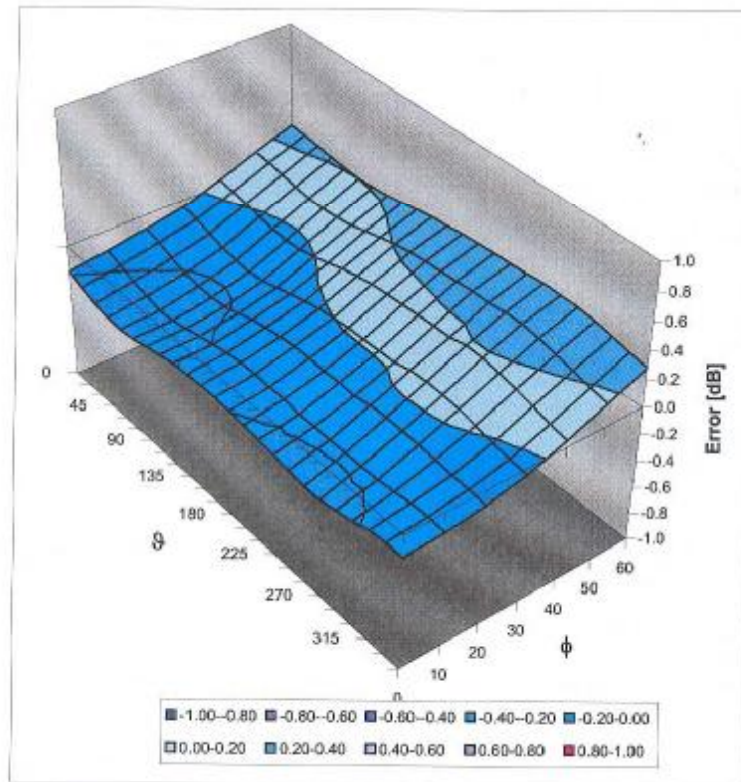

Uncertainty of Spherical Isotropy Assessment:  $\pm 2.6\%$  ( $k=2$ )

## 6. DAE Calibration certification

Schmid & Partner Engineering AG

**s p e a g**

Zeughausstrasse 43, 8004 Zurich, Switzerland  
Phone +41 44 245 9700, Fax +41 44 245 9779  
info@speag.com, http://www.speag.com

### IMPORTANT NOTICE

#### USAGE OF THE DAE 3

The DAE unit is a delicate, high precision instrument and requires careful treatment by the user. There are no serviceable parts inside the DAE. Special attention shall be given to the following points:

**Battery Exchange:** The battery cover of the DAE3 unit is connected to a fragile 3-pin battery connector. Customer is responsible to apply utmost caution not to bend or damage the connector when changing batteries.

**Shipping of the DAE:** Before shipping the DAE to SPEAG for calibration Customer shall remove the batteries and pack the DAE in an antistatic bag. The packaging shall protect the DAE from impacts during transportation. The package shall be marked to indicate that a fragile instrument is inside.

**E-Stop Failures:** Touch detection may be malfunctioning due to broken magnets in the E-stop. Rough handling of the E-stop may lead to damage of these magnets. Touch and collision errors are often caused by dust and dirt accumulated in the E-stop. To prevent E-stop failure, Customer shall always mount the probe to the DAE carefully and keep the DAE unit in a non-dusty environment if not used for measurements.

**Repair:** Minor repairs are performed at no extra cost during the annual calibration. However, SPEAG reserves the right to charge for any repair especially if rough unprofessional handling caused the defect.

**Important Note:**

**Warranty and calibration is void if the DAE unit is disassembled partly or fully by the Customer.**

**Important Note:**

**Never attempt to grease or oil the E-stop assembly. Cleaning and readjusting of the E-stop assembly is allowed by certified SPEAG personnel only and is part of the annual calibration procedure.**

Schmid & Partner Engineering

**Calibration Laboratory of  
 Schmid & Partner  
 Engineering AG**  
 Zeughausstrasse 43, 8004 Zurich, Switzerland



**S** Schweizerischer Kalibrierdienst  
**C** Service suisse d'étalonnage  
**S** Servizio svizzero di taratura  
**S** Swiss Calibration Service

Accredited by the Swiss Accreditation Service (SAS)  
 The Swiss Accreditation Service is one of the signatories to the EA  
 Multilateral Agreement for the recognition of calibration certificates

Accreditation No.: **SCS 108**

Client **SGS – CSTC (MTT)**

Certificate No: **DAE3-569\_Nov07**

**CALIBRATION CERTIFICATE**

Object **DAE3 - SD 000 D03 AA - SN: 569**

Calibration procedure(s) **QA CAL-06.v12  
 Calibration procedure for the data acquisition electronics (DAE)**

Calibration date: **November 19, 2007**

Condition of the calibrated item **In Tolerance**

This calibration certificate documents the traceability to national standards, which realize the physical units of measurements (SI).  
 The measurements and the uncertainties with confidence probability are given on the following pages and are part of the certificate.

All calibrations have been conducted in the closed laboratory facility: environment temperature (22 ± 3)°C and humidity < 70%.

Calibration Equipment used (M&TE critical for calibration)

Primary Standards	ID #	Cal Date (Calibrated by, Certificate No.)	Scheduled Calibration
Fluke Process Calibrator Type 702	SN: 6295803	04-Oct-07 (Elcal AG, No: 6467)	Oct-08
Keithley Multimeter Type 2001	SN: 0810278	03-Oct-07 (Elcal AG, No: 6465)	Oct-08
Secondary Standards	ID #	Check Date (in house)	Scheduled Check
Calibrator Box V1.1	SE UMS 006 AB 1004	25-Jun-07 (SPEAG, in house check)	In house check Jun-08

	Name	Function	Signature
Calibrated by:	Dominique Steffen	Technician	<i>[Signature]</i>
Approved by:	Fin Bornholt	R&D Director	<i>[Signature]</i>

Issued: November 19, 2007

This calibration certificate shall not be reproduced except in full without written approval of the laboratory.

**Calibration Laboratory of  
Schmid & Partner  
Engineering AG**  
Zeughausstrasse 43, 8004 Zurich, Switzerland



**S** Schweizerischer Kalibrierdienst  
**C** Service suisse d'étalonnage  
**S** Servizio svizzero di taratura  
**S** Swiss Calibration Service

Accredited by the Swiss Federal Office of Metrology and Accreditation  
The Swiss Accreditation Service is one of the signatories to the EA  
Multilateral Agreement for the recognition of calibration certificates

Accreditation No.: **SCS 108**

### Glossary

DAE data acquisition electronics  
Connector angle information used in DASY system to align probe sensor X to the robot coordinate system.

### Methods Applied and Interpretation of Parameters

- *DC Voltage Measurement:* Calibration Factor assessed for use in DASY system by comparison with a calibrated instrument traceable to national standards. The figure given corresponds to the full scale range of the voltmeter in the respective range.
- *Connector angle:* The angle of the connector is assessed measuring the angle mechanically by a tool inserted. Uncertainty is not required.
- The following parameters as documented in the Appendix contain technical information as a result from the performance test and require no uncertainty.
  - *DC Voltage Measurement Linearity:* Verification of the Linearity at +10% and -10% of the nominal calibration voltage. Influence of offset voltage is included in this measurement.
  - *Common mode sensitivity:* Influence of a positive or negative common mode voltage on the differential measurement.
  - *Channel separation:* Influence of a voltage on the neighbor channels not subject to an input voltage.
  - *AD Converter Values with inputs shorted:* Values on the internal AD converter corresponding to zero input voltage
  - *Input Offset Measurement:* Output voltage and statistical results over a large number of zero voltage measurements.
  - *Input Offset Current:* Typical value for information; Maximum channel input offset current, not considering the input resistance.
  - *Input resistance:* DAE input resistance at the connector, during internal auto-zeroing and during measurement.
  - *Low Battery Alarm Voltage:* Typical value for information. Below this voltage, a battery alarm signal is generated.
  - *Power consumption:* Typical value for information. Supply currents in various operating modes.



**DC Voltage Measurement**

A/D - Converter Resolution nominal

High Range: 1LSB = 6.1 $\mu$ V, full range = -100...+300 mV

Low Range: 1LSB = 61nV, full range = -1.....+3mV

DASY measurement parameters: Auto Zero Time: 3 sec; Measuring time: 3 sec

Calibration Factors	X	Y	Z
High Range	404.776 $\pm$ 0.1% (k=2)	404.362 $\pm$ 0.1% (k=2)	404.137 $\pm$ 0.1% (k=2)
Low Range	3.94862 $\pm$ 0.7% (k=2)	3.94274 $\pm$ 0.7% (k=2)	3.94290 $\pm$ 0.7% (k=2)

**Connector Angle**

Connector Angle to be used in DASY system	265 $^{\circ}$ $\pm$ 1 $^{\circ}$
---	-----------------------------------

## Appendix

## 1. DC Voltage Linearity

High Range	Input ( $\mu\text{V}$ )	Reading ( $\mu\text{V}$ )	Error (%)
Channel X + Input	200000	199999.4	0.00
Channel X + Input	20000	20003.10	0.02
Channel X - Input	20000	-19998.40	-0.01
Channel Y + Input	200000	199999.8	0.00
Channel Y + Input	20000	20000.56	0.00
Channel Y - Input	20000	-20003.76	0.02
Channel Z + Input	200000	199999.7	0.00
Channel Z + Input	20000	19999.91	0.00
Channel Z - Input	20000	-20001.93	0.01

Low Range	Input ( $\mu\text{V}$ )	Reading ( $\mu\text{V}$ )	Error (%)
Channel X + Input	2000	2000	0.00
Channel X + Input	200	199.91	-0.05
Channel X - Input	200	-200.13	0.06
Channel Y + Input	2000	2000	0.00
Channel Y + Input	200	198.90	-0.55
Channel Y - Input	200	-200.33	0.17
Channel Z + Input	2000	2000	0.00
Channel Z + Input	200	198.87	-0.56
Channel Z - Input	200	-200.97	0.48

## 2. Common mode sensitivity

DASY measurement parameters: Auto Zero Time: 3 sec; Measuring time: 3 sec

	Common mode Input Voltage (mV)	High Range Average Reading ( $\mu\text{V}$ )	Low Range Average Reading ( $\mu\text{V}$ )
Channel X	200	-5.51	-5.11
	- 200	9.14	5.16
Channel Y	200	7.38	7.24
	- 200	-8.13	-8.74
Channel Z	200	-5.41	-5.65
	- 200	4.60	4.15

## 3. Channel separation

DASY measurement parameters: Auto Zero Time: 3 sec; Measuring time: 3 sec

	Input Voltage (mV)	Channel X ( $\mu\text{V}$ )	Channel Y ( $\mu\text{V}$ )	Channel Z ( $\mu\text{V}$ )
Channel X	200	-	1.82	0.97
Channel Y	200	0.44	-	3.38
Channel Z	200	-0.57	-0.43	-

**4. AD-Converter Values with inputs shorted**

DASY measurement parameters: Auto Zero Time: 3 sec; Measuring time: 3 sec

	High Range (LSB)	Low Range (LSB)
Channel X	16395	15475
Channel Y	15747	16647
Channel Z	16314	16212

**5. Input Offset Measurement**

DASY measurement parameters: Auto Zero Time: 3 sec; Measuring time: 3 sec

Input 10M $\Omega$ 

	Average ( $\mu$ V)	min. Offset ( $\mu$ V)	max. Offset ( $\mu$ V)	Std. Deviation ( $\mu$ V)
Channel X	-0.02	-0.85	1.22	0.32
Channel Y	-0.62	-1.53	0.45	0.30
Channel Z	-0.95	-2.89	-0.14	0.35

**6. Input Offset Current**

Nominal Input circuitry offset current on all channels: &lt;25fA

**7. Input Resistance**

	Zeroing (MOhm)	Measuring (MOhm)
Channel X	0.2000	199.3
Channel Y	0.2000	203.2
Channel Z	0.2001	204.8

**8. Low Battery Alarm Voltage** (verified during pre test)

Typical values	Alarm Level (VDC)
Supply (+ Vcc)	+7.9
Supply (- Vcc)	-7.6

**9. Power Consumption** (verified during pre test)

Typical values	Switched off (mA)	Stand by (mA)	Transmitting (mA)
Supply (+ Vcc)	+0.0	+6	+14
Supply (- Vcc)	-0.01	-8	-9

**7. Dipole Calibration certification**

**Calibration Laboratory of  
Schmid & Partner  
Engineering AG**  
Zeughausstrasse 43, 8304 Zurich, Switzerland



**S** Schweizerischer Kalibrierdienst  
**C** Service suisse d'étalonnage  
**S** Servizio svizzero di taratura  
**S** Swiss Calibration Service

Accredited by the Swiss Accreditation Service (SAS)  
The Swiss Accreditation Service is one of the signatories to the EA  
Multilateral Agreement for the recognition of calibration certificates

Accreditation No.: **SCS 108**Client **SGS China (Auden)**Certificate No. **D900V2-184\_Dec07****CALIBRATION CERTIFICATE**

Object: **D900V2 - SN: 184**

Calibration procedure(s): **QA CAL-05.v7  
Calibration procedure for dipole validation kits**

Calibration date: **December 21, 2007**

Condition of the calibrated item: **In Tolerance**

This calibration certificate documents the traceability to national standards, which realize the physical units of measurements (SI).  
The measurements and the uncertainties with confidence probability are given on the following pages and are part of the certificate.

All calibrations have been conducted in the closed laboratory facility: environment temperature  $(22 \pm 3)^\circ\text{C}$  and humidity  $< 70\%$ .

Calibration Equipment used (M&PE critical for calibration)

Primary Standards	ID #	Cal Date (Calibrated by, Certificate No.)	Scheduled Calibration
Power meter EPM-442A	GB37480704	04-Oct-07 (METAS, No. 217-00736)	Oct-08
Power sensor HP 8481A	US37252783	04-Oct-07 (METAS, No. 217-00736)	Oct-08
Reference 20 dB Attenuator	SN: 5066 (20g)	07-Aug-07 (METAS, No 217-00718)	Aug-08
Reference 10 dB Attenuator	SN: 5047.2 (10r)	07-Aug-07 (METAS, No 217-00718)	Aug-08
Reference Probe ET3DV6 (HF)	SN 1507	26-Oct-07 (SPEAG, No. ET3-1507_Oct07)	Oct-08
DAE4	SN 601	30-Jan-07 (SPEAG, No. DAE4-601_Jan07)	Jan-08
Secondary Standards	ID #	Check Date (in house)	Scheduled Check
Power sensor HP 8481A	MY41092317	18-Oct-02 (SPEAG, in house check Oct-07)	In house check: Oct-09
RF generator R&S SMT-06	100005	4-Aug-99 (SPEAG, in house check Oct-07)	In house check: Oct-09
Network Analyzer HP 8753E	US37390565 S4206	18-Oct-01 (SPEAG, in house check Oct-07)	In house check: Oct-08

Calibrated by:	Name	Function	Signature
	Mike Meli	Laboratory Technician	
Approved by:	Katja Pokovic	Technical Manager	

Issued: December 21, 2007

This calibration certificate shall not be reproduced except in full without written approval of the laboratory.



**Calibration Laboratory of  
Schmid & Partner  
Engineering AG**  
Zeughausstrasse 43, 8004 Zurich, Switzerland



**S** Schweizerischer Kalibrierdienst  
**C** Service suisse d'étalonnage  
**S** Servizio svizzero di taratura  
**S** Swiss Calibration Service

Accredited by the Swiss Accreditation Service (SAS)

The Swiss Accreditation Service is one of the signatories to the EA  
Multilateral Agreement for the recognition of calibration certificates

Accreditation No.: **SCS 108**

**Glossary:**

TSL	tissue simulating liquid
ConvF	sensitivity in TSL / NORM x,y,z
N/A	not applicable or not measured

**Calibration is Performed According to the Following Standards:**

- a) IEEE Std 1528-2003, "IEEE Recommended Practice for Determining the Peak Spatial-Averaged Specific Absorption Rate (SAR) in the Human Head from Wireless Communications Devices: Measurement Techniques", December 2003
- b) IEC 62209-1, "Procedure to measure the Specific Absorption Rate (SAR) for hand-held devices used in close proximity to the ear (frequency range of 300 MHz to 3 GHz)", February 2005
- c) Federal Communications Commission Office of Engineering & Technology (FCC OET), "Evaluating Compliance with FCC Guidelines for Human Exposure to Radiofrequency Electromagnetic Fields; Additional Information for Evaluating Compliance of Mobile and Portable Devices with FCC Limits for Human Exposure to Radiofrequency Emissions", Supplement C (Edition 01-01) to Bulletin 65

**Additional Documentation:**

- d) DASY4 System Handbook

**Methods Applied and Interpretation of Parameters:**

- *Measurement Conditions:* Further details are available from the Validation Report at the end of the certificate. All figures stated in the certificate are valid at the frequency indicated.
- *Antenna Parameters with TSL:* The dipole is mounted with the spacer to position its feed point exactly below the center marking of the flat phantom section, with the arms oriented parallel to the body axis.
- *Feed Point Impedance and Return Loss:* These parameters are measured with the dipole positioned under the liquid filled phantom. The impedance stated is transformed from the measurement at the SMA connector to the feed point. The Return Loss ensures low reflected power. No uncertainty required.
- *Electrical Delay:* One-way delay between the SMA connector and the antenna feed point. No uncertainty required.
- *SAR measured:* SAR measured at the stated antenna input power.
- *SAR normalized:* SAR as measured, normalized to an input power of 1 W at the antenna connector.
- *SAR for nominal TSL parameters:* The measured TSL parameters are used to calculate the nominal SAR result.

**Measurement Conditions**

DASY system configuration, as far as not given on page 1.

DASY Version	DASY4	V4.7
Extrapolation	Advanced Extrapolation	
Phantom	Modular Flat Phantom V4.9	
Distance Dipole Center - TSL	15 mm	with Spacer
Zoom Scan Resolution	dx, dy, dz = 5 mm	
Frequency	900 MHz $\pm$ 1 MHz	

**Head TSL parameters**

The following parameters and calculations were applied.

	Temperature	Permittivity	Conductivity
Nominal Head TSL parameters	22.0 °C	41.5	0.97 mho/m
Measured Head TSL parameters	(22.0 $\pm$ 0.2) °C	42.5 $\pm$ 6 %	0.98 mho/m $\pm$ 6 %
Head TSL temperature during test	(22.1 $\pm$ 0.2) °C	---	----

**SAR result with Head TSL**

SAR averaged over 1 cm <sup>3</sup> (1 g) of Head TSL	Condition	
SAR measured	250 mW input power	2.73 mW / g
SAR normalized	normalized to 1W	10.9 mW / g
SAR for nominal Head TSL parameters <sup>1</sup>	normalized to 1W	<b>11.0 mW / g <math>\pm</math> 17.0 % (k=2)</b>

SAR averaged over 10 cm <sup>3</sup> (10 g) of Head TSL	condition	
SAR measured	250 mW input power	1.75 mW / g
SAR normalized	normalized to 1W	7.00 mW / g
SAR for nominal Head TSL parameters <sup>1</sup>	normalized to 1W	<b>7.05 mW / g <math>\pm</math> 16.5 % (k=2)</b>

<sup>1</sup> Correction to nominal TSL parameters according to d), chapter "SAR Sensitivities"

**Body TSL parameters**

The following parameters and calculations were applied.

	Temperature	Permittivity	Conductivity
Nominal Body TSL parameters	22.0 °C	55.0	1.05 mho/m
Measured Body TSL parameters	(22.0 ± 0.2) °C	54.2 ± 6 %	1.06 mho/m ± 6 %
Body TSL temperature during test	(22.6 ± 0.2) °C	----	----

**SAR result with Body TSL**

SAR averaged over 1 cm <sup>3</sup> (1 g) of Body TSL	Condition	
SAR measured	250 mW input power	2.90 mW / g
SAR normalized	normalized to 1W	11.6 mW / g
SAR for nominal Body TSL parameters <sup>2</sup>	normalized to 1W	<b>11.4 mW / g ± 17.0 % (k=2)</b>

SAR averaged over 10 cm <sup>3</sup> (10 g) of Body TSL	condition	
SAR measured	250 mW input power	1.87 mW / g
SAR normalized	normalized to 1W	7.48 mW / g
SAR for nominal Body TSL parameters <sup>2</sup>	normalized to 1W	<b>7.40 mW / g ± 16.5 % (k=2)</b>

<sup>2</sup> Correction to nominal TSL parameters according to d), chapter "SAR Sensitivities"

## Appendix

### Antenna Parameters with Head TSL

Impedance, transformed to feed point	48.8 $\Omega$ - 7.5 j $\Omega$
Return Loss	- 22.3 dB

### Antenna Parameters with Body TSL

Impedance, transformed to feed point	45.3 $\Omega$ - 9.4 j $\Omega$
Return Loss	- 19.1 dB

### General Antenna Parameters and Design

Electrical Delay (one direction)	1.411 ns
----------------------------------	----------

After long term use with 100W radiated power, only a slight warming of the dipole near the feedpoint can be measured.

The dipole is made of standard semirigid coaxial cable. The center conductor of the feeding line is directly connected to the second arm of the dipole. The antenna is therefore short-circuited for DC-signals.

No excessive force must be applied to the dipole arms, because they might bend or the soldered connections near the feedpoint may be damaged.

### Additional EUT Data

Manufactured by	SPEAG
Manufactured on	April 1, 2003



## DASY4 Validation Report for Head TSL

Date/Time: 21.12.2007 14:51:24

Test Laboratory: SPEAG, Zurich, Switzerland

**DUT: Dipole 900 MHz; Type: D900V2; Serial: D900V2 - SN:184**

Communication System: CW; Frequency: 900 MHz; Duty Cycle: 1:1  
Medium: HSL 900 MHz;  
Medium parameters used:  $f = 900$  MHz;  $\sigma = 0.98$  mho/m;  $\epsilon_r = 42.5$ ;  $\rho = 1000$  kg/m<sup>3</sup>  
Phantom section: Flat Section  
Measurement Standard: DASY4 (High Precision Assessment)

### DASY4 Configuration:

- Probe: ET3DV6 - SN1507 (HF); ConvF(5.93, 5.93, 5.93); Calibrated: 26.10.2007
- Sensor-Surface: 4mm (Mechanical Surface Detection)
- Electronics: DAE4 Sn601; Calibrated: 30.01.2007
- Phantom: Flat Phantom 4.9L; Type: QD000P49AA
- Measurement SW: DASY4, V4.7 Build 55; Postprocessing SW: SEMCAD, V1.8 Build 172

### Pin = 250 mW; d = 15 mm/Zoom Scan (7x7x7)/Cube 0:

Measurement grid: dx=5mm, dy=5mm, dz=5mm  
Reference Value = 56.9 V/m; Power Drift = -0.012 dB  
Peak SAR (extrapolated) = 4.06 W/kg  
SAR(1 g) = 2.73 mW/g; SAR(10 g) = 1.75 mW/g  
Maximum value of SAR (measured) = 2.95 mW/g

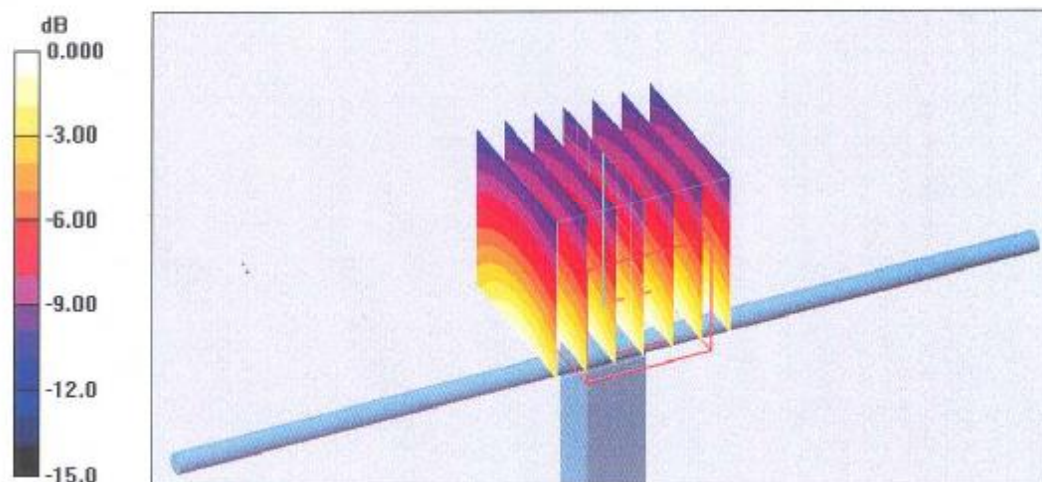

0 dB  $\Rightarrow$  2.95mW/g

### Impedance Measurement Plot for Head TSL

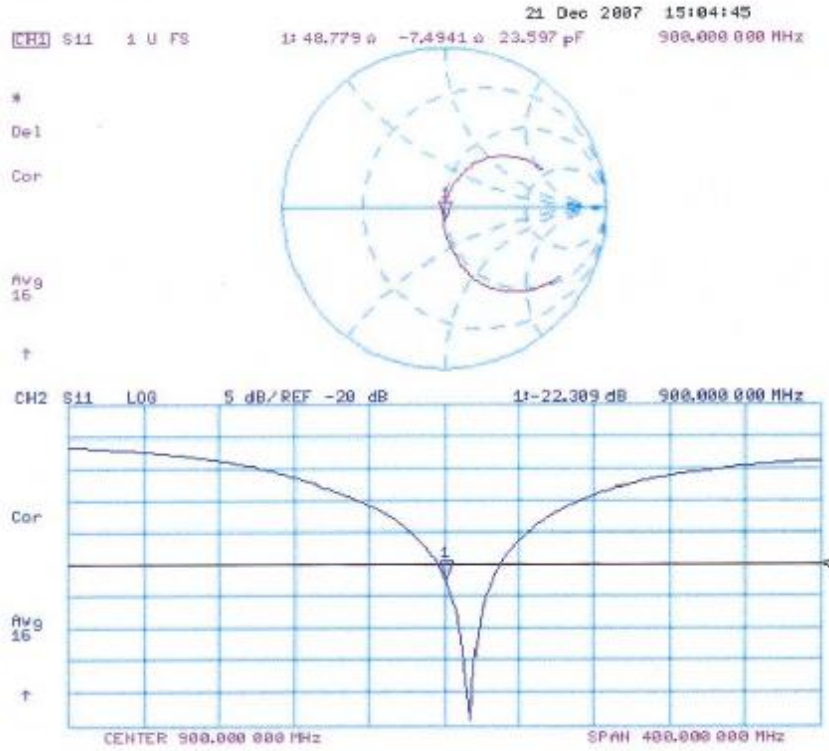

### DASY4 Validation Report for Body TSL

Date/Time: 21.12.2007 15:46:31

Test Laboratory: SPEAG, Zurich, Switzerland

**DUT: Dipole 900 MHz; Type: D900V2; Serial: D900V2 - SN:184**

Communication System: CW; Frequency: 900 MHz; Duty Cycle: 1:1

Medium: MSL900;

Medium parameters used:  $f = 900$  MHz;  $\sigma = 1.06$  mho/m;  $\epsilon_r = 54.2$ ;  $\rho = 1000$  kg/m<sup>3</sup>

Phantom section: Flat Section

Measurement Standard: DASY4 (High Precision Assessment)

DASY4 Configuration:

- Probe: ET3DV6 - SN1507 (HF); ConvF(5.57, 5.57, 5.57); Calibrated: 26.10.2007
- Sensor-Surface: 4mm (Mechanical Surface Detection)
- Electronics: DAE4 Sn601; Calibrated: 30.01.2007
- Phantom: Flat Phantom 4.9L; Type: QD000P49AA
- Measurement SW: DASY4, V4.7 Build 55; Postprocessing SW: SEMCAD, V1.8 Build 172

**Pin=250mW/Zoom Scan (7x7x7)/Cube 0:**

Measurement grid: dx=5mm, dy=5mm, dz=5mm

Reference Value = 56.9 V/m; Power Drift = 0.008 dB

Peak SAR (extrapolated) = 4.23 W/kg

**SAR(1 g) = 2.9 mW/g; SAR(10 g) = 1.87 mW/g**

Maximum value of SAR (measured) = 3.16 mW/g

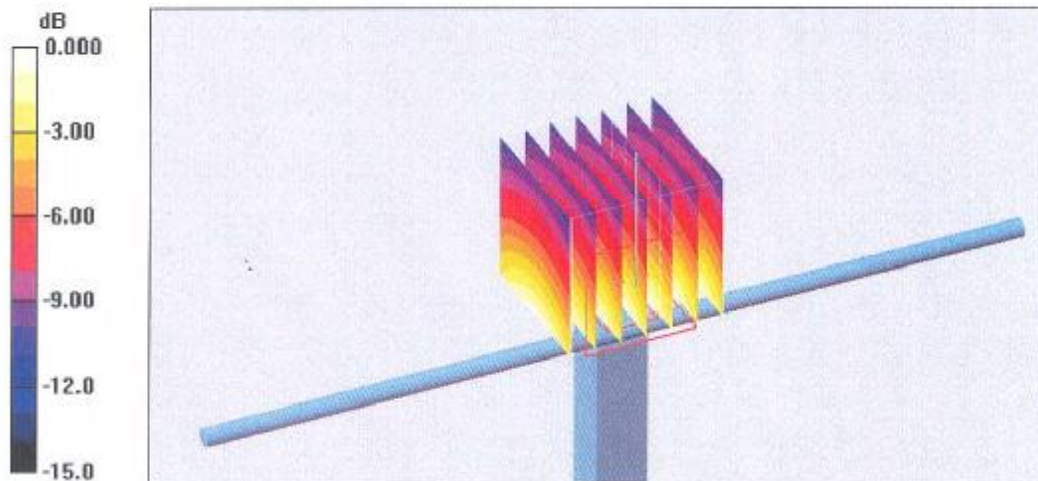

### Impedance Measurement Plot for Body TSL

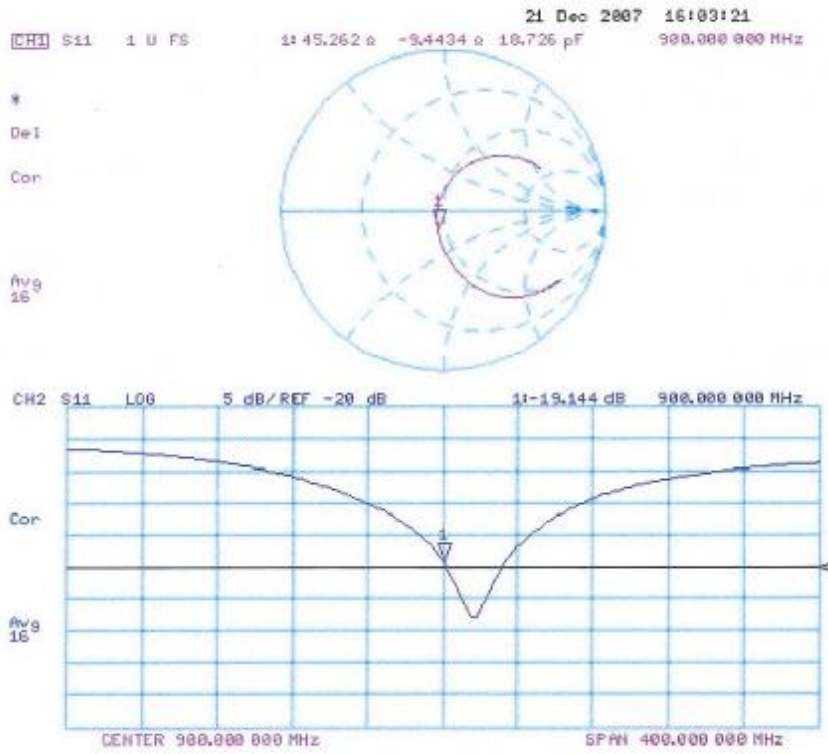



**Calibration Laboratory of  
 Schmid & Partner  
 Engineering AG**  
 Zeughausstrasse 43, 8004 Zurich, Switzerland



**S** Schweizerischer Kalibrierdienst  
**S** Service suisse d'étalonnage  
**C** Servizio svizzero di taratura  
**S** Swiss Calibration Service

Accredited by the Swiss Accreditation Service (SAS)  
 The Swiss Accreditation Service is one of the signatories to the EA  
 Multilateral Agreement for the recognition of calibration certificates

Accreditation No.: **SCS 108**

Client **SGS China (Auden)**

Certificate No: **D1900V2-5d028\_Dec07**

**CALIBRATION CERTIFICATE**

Object **D1900V2 - SN: 5d028**

Calibration procedure(s) **QA CAL-05.v7  
 Calibration procedure for dipole validation kits**

Calibration date: **December 21, 2007**

Condition of the calibrated item **In Tolerance**

This calibration certificate documents the traceability to national standards, which realize the physical units of measurements (SI).  
 The measurements and the uncertainties with confidence probability are given on the following pages and are part of the certificate.

All calibrations have been conducted in the closed laboratory facility: environment temperature (22 ± 3)°C and humidity < 70%.

Calibration Equipment used (M&TE critical for calibration)

Primary Standards	ID #	Cal Date (Calibrated by, Certificate No.)	Scheduled Calibration
Power meter EPM-442A	GB37480704	04-Oct-07 (METAS, No. 217-00736)	Oct-08
Power sensor HP 8481A	US37292783	04-Oct-07 (METAS, No. 217-00736)	Oct-08
Reference 20 dB Attenuator	SN: 5086 (20g)	07-Aug-07 (METAS, No 217-00718)	Aug-08
Reference 10 dB Attenuator	SN: 5047.2 (10r)	07-Aug-07 (METAS, No 217-00718)	Aug-08
Reference Probe ET3DV6 (HF)	SN: 1507	26-Oct-07 (SPEAG, No. ET3-1507_Oct07)	Oct-08
DAE4	SN 601	30-Jan-07 (SPEAG, No. DAE4-601_Jan07)	Jan-08
Secondary Standards	ID #	Check Date (in house)	Scheduled Check
Power sensor HP 8481A	MY41092317	18-Oct-02 (SPEAG, in house check Oct-07)	In house check: Oct-08
RF generator R&S SMT-06	100005	4-Aug-99 (SPEAG, in house check Oct-07)	In house check: Oct-09
Network Analyzer HP 8753E	US37390585 S4206	18-Oct-01 (SPEAG, in house check Oct-07)	In house check: Oct-08

Calibrated by: **Name** Claudio Leubler **Function** Laboratory Technician **Signature** *[Signature]*

Approved by: **Name** Katja Pokovic **Function** Technical Manager **Signature** *[Signature]*

Issued: December 31, 2007

This calibration certificate shall not be reproduced except in full without written approval of the laboratory.

**Calibration Laboratory of  
Schmid & Partner  
Engineering AG**  
Zeughausstrasse 43, 8004 Zurich, Switzerland



**S** Schweizerischer Kalibrierdienst  
**C** Service suisse d'étalonnage  
**S** Servizio svizzero di taratura  
**S** Swiss Calibration Service

Accredited by the Swiss Accreditation Service (SAS)  
The Swiss Accreditation Service is one of the signatories to the EA  
Multilateral Agreement for the recognition of calibration certificates

Accreditation No.: **SCS 108**

**Glossary:**

TSL	tissue simulating liquid
ConvF	sensitivity in TSL / NORM x,y,z
N/A	not applicable or not measured

**Calibration is Performed According to the Following Standards:**

- IEEE Std 1528-2003, "IEEE Recommended Practice for Determining the Peak Spatial-Averaged Specific Absorption Rate (SAR) in the Human Head from Wireless Communications Devices: Measurement Techniques", December 2003
- IEC 62209-1, "Procedure to measure the Specific Absorption Rate (SAR) for hand-held devices used in close proximity to the ear (frequency range of 300 MHz to 3 GHz)", February 2005
- Federal Communications Commission Office of Engineering & Technology (FCC OET), "Evaluating Compliance with FCC Guidelines for Human Exposure to Radiofrequency Electromagnetic Fields; Additional Information for Evaluating Compliance of Mobile and Portable Devices with FCC Limits for Human Exposure to Radiofrequency Emissions", Supplement C (Edition 01-01) to Bulletin 65

**Additional Documentation:**

- DASY4 System Handbook

**Methods Applied and Interpretation of Parameters:**

- Measurement Conditions:* Further details are available from the Validation Report at the end of the certificate. All figures stated in the certificate are valid at the frequency indicated.
- Antenna Parameters with TSL:* The dipole is mounted with the spacer to position its feed point exactly below the center marking of the flat phantom section, with the arms oriented parallel to the body axis.
- Feed Point Impedance and Return Loss:* These parameters are measured with the dipole positioned under the liquid filled phantom. The impedance stated is transformed from the measurement at the SMA connector to the feed point. The Return Loss ensures low reflected power. No uncertainty required.
- Electrical Delay:* One-way delay between the SMA connector and the antenna feed point. No uncertainty required.
- SAR measured:* SAR measured at the stated antenna input power.
- SAR normalized:* SAR as measured, normalized to an input power of 1 W at the antenna connector.
- SAR for nominal TSL parameters:* The measured TSL parameters are used to calculate the nominal SAR result.

**Measurement Conditions**

DASY system configuration, as far as not given on page 1.

DASY Version	DASY4	V4.7
Extrapolation	Advanced Extrapolation	
Phantom	Modular Flat Phantom V5.0	
Distance Dipole Center - TSL	10 mm	with Spacer
Zoom Scan Resolution	dx, dy, dz = 5 mm	
Frequency	1900 MHz $\pm$ 1 MHz	

**Head TSL parameters**

The following parameters and calculations were applied.

	Temperature	Permittivity	Conductivity
Nominal Head TSL parameters	22.0 °C	40.0	1.40 mho/m
Measured Head TSL parameters	(22.0 $\pm$ 0.2) °C	39.0 $\pm$ 6 %	1.46 mho/m $\pm$ 6 %
Head TSL temperature during test	(21.5 $\pm$ 0.2) °C	---	---

**SAR result with Head TSL**

SAR averaged over 1 cm <sup>3</sup> (1 g) of Head TSL	condition	
SAR measured	250 mW input power	9.82 mW / g
SAR normalized	normalized to 1W	39.3 mW / g
SAR for nominal Head TSL parameters <sup>1</sup>	normalized to 1W	<b>37.9 mW / g <math>\pm</math> 17.0 % (k=2)</b>

SAR averaged over 10 cm <sup>3</sup> (10 g) of Head TSL	Condition	
SAR measured	250 mW input power	5.14 mW / g
SAR normalized	normalized to 1W	20.6 mW / g
SAR for nominal Head TSL parameters <sup>1</sup>	normalized to 1W	<b>20.2 mW / g <math>\pm</math> 16.5 % (k=2)</b>

<sup>1</sup> Correction to nominal TSL parameters according to d), chapter "SAR Sensitivities"



**Body TSL parameters**

The following parameters and calculations were applied.

	Temperature	Permittivity	Conductivity
Nominal Body TSL parameters	22.0 °C	53.3	1.52 mho/m
Measured Body TSL parameters	(22.0 ± 0.2) °C	53.5 ± 6 %	1.54 mho/m ± 6 %
Body TSL temperature during test	(21.5 ± 0.2) °C	---	---

**SAR result with Body TSL**

SAR averaged over 1 cm <sup>3</sup> (1 g) of Body TSL	Condition	
SAR measured	250 mW input power	9.34 mW / g
SAR normalized	normalized to 1W	37.4 mW / g
SAR for nominal Body TSL parameters <sup>2</sup>	normalized to 1W	<b>37.2 mW / g ± 17.0 % (k=2)</b>

SAR averaged over 10 cm <sup>3</sup> (10 g) of Body TSL	condition	
SAR measured	250 mW input power	4.97 mW / g
SAR normalized	normalized to 1W	19.9 mW / g
SAR for nominal Body TSL parameters <sup>2</sup>	normalized to 1W	<b>19.8 mW / g ± 16.5 % (k=2)</b>

<sup>2</sup> Correction to nominal TSL parameters according to d), chapter "SAR Sensitivities"

**Appendix****Antenna Parameters with Head TSL**

Impedance, transformed to feed point	$53.7 \Omega + 5.2 j\Omega$
Return Loss	- 24.3 dB

**Antenna Parameters with Body TSL**

Impedance, transformed to feed point	$49.5 \Omega + 3.4 j\Omega$
Return Loss	- 29.1 dB

**General Antenna Parameters and Design**

Electrical Delay (one direction)	1.198 ns
----------------------------------	----------

After long term use with 100W radiated power, only a slight warming of the dipole near the feedpoint can be measured.

The dipole is made of standard semirigid coaxial cable. The center conductor of the feeding line is directly connected to the second arm of the dipole. The antenna is therefore short-circuited for DC-signals.

No excessive force must be applied to the dipole arms, because they might bend or the soldered connections near the feedpoint may be damaged.

**Additional EUT Data**

Manufactured by	SPEAG
Manufactured on	December 17, 2002

### DASY4 Validation Report for Head TSL

Date/Time: 21.12.2007 09:54:50

Test Laboratory: SPEAG, Zurich, Switzerland

**DUT: Dipole 1900 MHz; Type: D1900V2; Serial: D1900V2 - SN:5d028**

Communication System: CW; Frequency: 1900 MHz; Duty Cycle: 1:1  
Medium: HSL U10 BB;  
Medium parameters used:  $f = 1900$  MHz;  $\sigma = 1.46$  mho/m;  $\epsilon_r = 39$ ;  $\rho = 1000$  kg/m<sup>3</sup>  
Phantom section: Flat Section  
Measurement Standard: DASY4 (High Precision Assessment)

#### DASY4 Configuration:

- Probe: ET3DV6 - SN1507 (HF); ConvF(4.86, 4.86, 4.86); Calibrated: 26.10.2007
- Sensor-Surface: 4mm (Mechanical Surface Detection)
- Electronics: DAE4 Sn601; Calibrated: 30.01.2007
- Phantom: Flat Phantom 5.0 (front); Type: QD000P50AA; ;
- Measurement SW: DASY4, V4.7 Build 55; Postprocessing SW: SEMCAD, V1.8 Build 172

#### **Pin = 250 mW; d = 10 mm/Zoom Scan (7x7x7)/Cube 0:**

Measurement grid:  $dx=5$ mm,  $dy=5$ mm,  $dz=5$ mm  
Reference Value = 89.9 V/m; Power Drift = 0.010 dB  
Peak SAR (extrapolated) = 17.2 W/kg  
**SAR(1 g) = 9.82 mW/g; SAR(10 g) = 5.14 mW/g**  
Maximum value of SAR (measured) = 10.9 mW/g

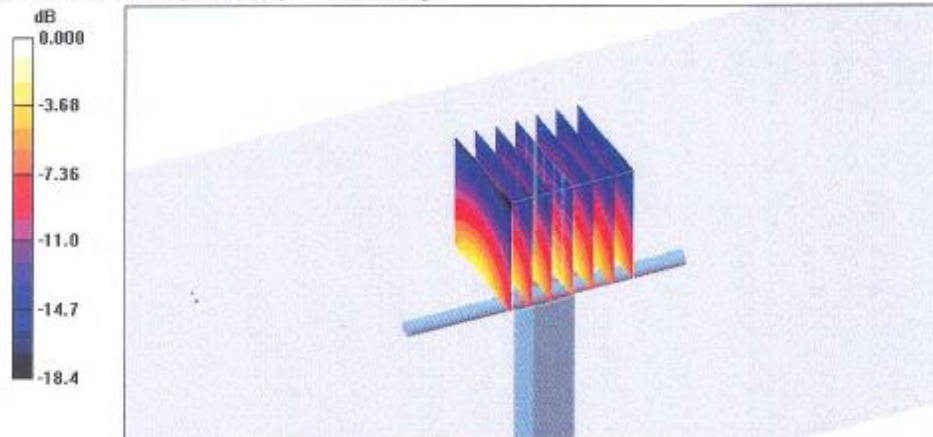

0 dB = 10.9mW/g

### Impedance Measurement Plot for Head TSL

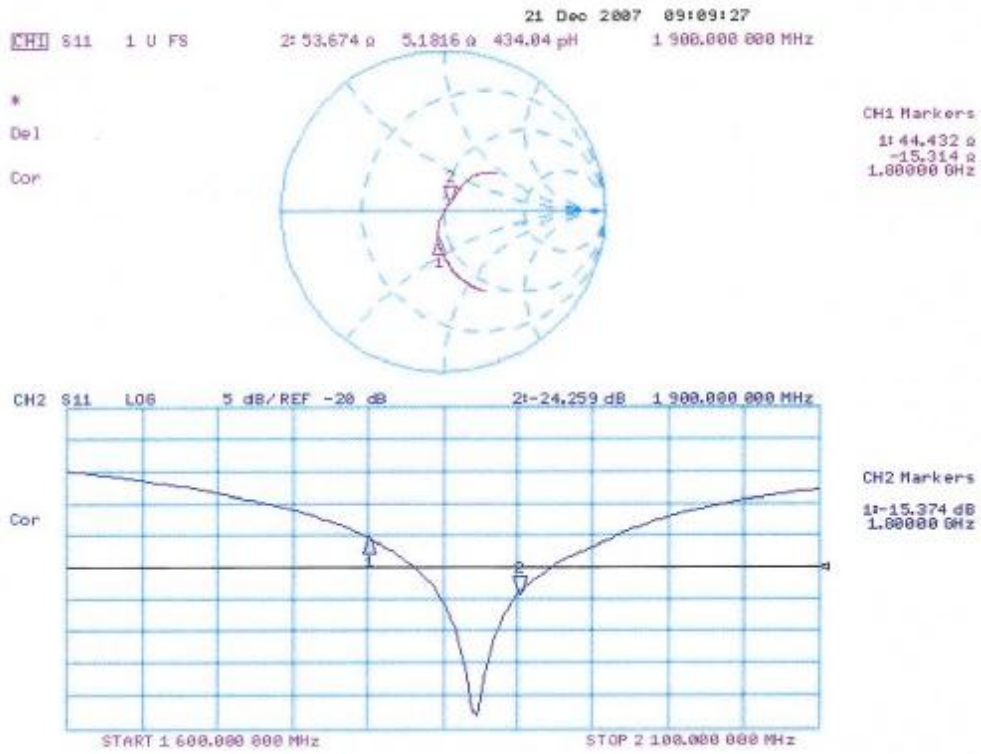

**DASY4 Validation Report for Body TSL**

Date/Time: 21.12.2007 11:05:06

Test Laboratory: SPEAG, Zurich, Switzerland

**DUT: Dipole 1900 MHz; Type: D1900V2; Serial: D1900V2 - SN:5d028**

Communication System: CW; Frequency: 1900 MHz; Duty Cycle: 1:1

Medium: MSL U10 BB;

Medium parameters used:  $f = 1900$  MHz;  $\sigma = 1.54$  mho/m;  $\epsilon_r = 53.6$ ;  $\rho = 1000$  kg/m<sup>3</sup>

Phantom section: Flat Section

Measurement Standard: DASY4 (High Precision Assessment)

**DASY4 Configuration:**

- Probe: ET3DV6 - SN1507 (HF); ConvF(4.48, 4.48, 4.48); Calibrated: 26.10.2007
- Sensor-Surface: 4mm (Mechanical Surface Detection)
- Electronics: DAE4 Sn601; Calibrated: 30.01.2007
- Phantom: Flat Phantom 5.0 (back); Type: QD000P50AA; ;
- Measurement SW: DASY4, V4.7 Build 55; Postprocessing SW: SEMCAD, V1.8 Build 172

**Pin = 250 mW; d = 10 mm/Zoom Scan (7x7x7)/Cube 0:**

Measurement grid: dx=5mm, dy=5mm, dz=5mm

Reference Value = 89.3 V/m; Power Drift = -0.044 dB

Peak SAR (extrapolated) = 16.0 W/kg

**SAR(1 g) = 9.34 mW/g; SAR(10 g) = 4.97 mW/g**

Maximum value of SAR (measured) = 10.5 mW/g

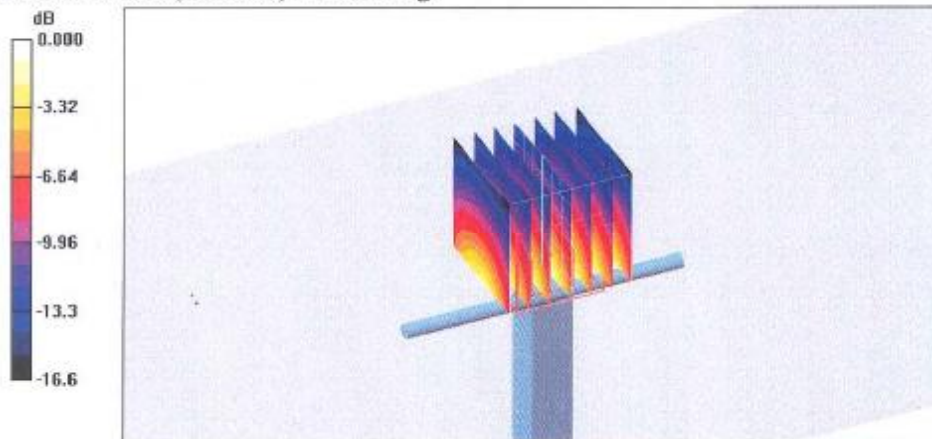

0 dB = 10.5mW/g



### Impedance Measurement Plot for Body TSL

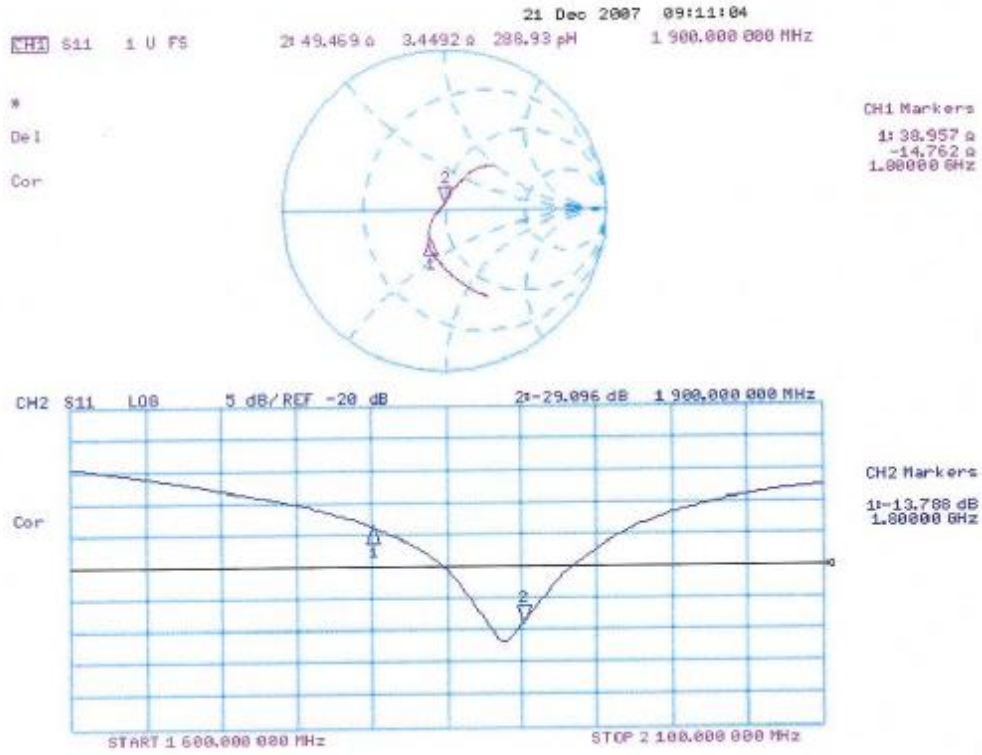

**8. Uncertainty analysis**

Error Description	Tol. (± %)	Prob. dist.	Div.	( $c_1$ ) (1g)	( $c_2$ ) (10g)	Std. unc. (± %)		( $v_i$ )
Measurement System								
Probe Calibration	4.8	N	1	1	1	4.8	4.8	∞
Axial Isotropy	4.7	R	$\sqrt{3}$	1	1	2.7	2.7	∞
Hemispherical Isotropy	0	R	$\sqrt{3}$	1	1	0	0	∞
Boundary Effects	1.0	R	$\sqrt{3}$	1	1	0.6	0.6	∞
Linearity	4.7	R	$\sqrt{3}$	1	1	2.7	2.7	∞
System Detection Limit	1.0	R	$\sqrt{3}$	1	1	0.6	0.6	∞
Readout Electronics	1.0	N	1	1	1	1.0	1.0	∞
Response Time	0	R	$\sqrt{3}$	1	1	0	0	∞
Integration Time	0	R	$\sqrt{3}$	1	1	0	0	∞
RF Ambient Conditions	3.0	R	$\sqrt{3}$	1	1	1.7	1.7	∞
Probe Positioner	0.4	R	$\sqrt{3}$	1	1	0.2	0.2	∞
Probe Positioning	2.9	R	$\sqrt{3}$	1	1	1.7	1.7	∞
Algorithms for Max. SAR Eval.	1.0	R	$\sqrt{3}$	1	1	0.6	0.6	∞
Dipole								
Dipole Axis to Liquid Distance	2.0	R	$\sqrt{3}$	1	1	1.2	1.2	∞
Input power and SAR drift meas.	4.7	R	$\sqrt{3}$	1	1	2.7	2.7	∞
Phantom and Tissue Param.								
Phantom Uncertainty	4.0	R	$\sqrt{3}$	1	1	2.3	2.3	∞
Liquid Conductivity (target)	5.0	R.	$\sqrt{3}$	0.64	0.43	1.8	1.2	∞
Liquid Conductivity (meas.)	2.5	N	1	0.64	0.43	1.6	1.1	∞
Liquid Permittivity (target)	5.0	R	$\sqrt{3}$	0.6	0.49	1.7	1.4	∞
Liquid Permittivity (meas.)	2.5	N	1	0.6	0.49	1.5	1.2	∞
Combined Standard Uncertainty						8.4	8.1	∞
Coverage Factor for 95%		kp=2						
Expanded Uncertainty						16.8	16.2	

**Dasy4 Uncertainty Budget**

## 9. Phantom description

**Schmid & Partner  
Engineering AG**

Zeughausstrasse 43, 8004 Zurich, Switzerland, Phone +41 1 245 97 00, Fax +41 1 245 97 79

**Certificate of conformity / First Article Inspection**

Item	SAM Twin Phantom V4.0
Type No	QD 000 P40 CA
Series No	TP-1150 and higher
Manufacturer / Origin	Unterse Composites Hauptstr. 69 CH-8559 Fruttwilen Switzerland

**Tests**

The series production process used allows the limitation to test of first articles. Complete tests were made on the pre-series Type No. QD 000 P40 AA, Serial No. TP-1001 and on the series first article Type No. QD 000 P40 BA, Serial No. TP-1006. Certain parameters have been retested using further series units (called samples).

Test	Requirement	Details	Units tested
Shape	Compliance with the geometry according to the CAD model.	ITIS CAD File (*)	First article, Samples
Material thickness	Compliant with the requirements according to the standards	2mm +/- 0.2mm in specific areas	First article, Samples
Material parameters	Dielectric parameters for required frequencies	200 MHz – 3 GHz Relative permittivity < 5 Loss tangent < 0.05.	Material sample TP 104-5
Material resistivity	The material has been tested to be compatible with the liquids defined in the standards	Liquid type HSL 1800 and others according to the standard.	Pre-series, First article

**Standards**

- [1] CENELEC EN 50361  
 [2] IEEE P1528-200x draft 6.5  
 [3] IEC PT 62209 draft 0.9  
 (\*) The ITIS CAD file is derived from [2] and is also within the tolerance requirements of the shapes of [1] and [3].

**Conformity**

Based on the sample tests above, we certify that this item is in compliance with the uncertainty requirements of SAR measurements specified in standard [1] and draft standards [2] and [3].

Date 28.02.2002

Signature / Stamp

*F. Rombult***Schmid & Partner  
Engineering AG**Zeughausstrasse 43, CH-8004 Zurich  
Tel. +41 1 245 97 00, Fax +41 1 245 97 79*Volker Kapp***End of Report**