

# ELECTROMAGNETIC EMISSIONS COMPLIANCE REPORT

## INTENTIONAL RADIATOR CERTIFICATION TO FCC PART 22 SUBPART H and PART 24 SUBPART E

OF

**Product Name:** GSM850/PCS1900 mobile phone

**Brand Name:** ALCATEL

**Model Name:** U81CA

**Market Name:** OT-S210A

**FCC ID:** RAD077

**Report No:** ER/2008/40033

**Issue Date:** Aug. 04, 2008

**FCC Rule Part:** 2, 22H & 24E

**Prepared for:** TCT Mobile Suzhou Limited  
3/F,B2 Block,Digital Technology Yard,  
Gaoxin Nan Qi Road,Nan Shan District,  
Shenzhen,Guangdong,P.R.China

**Prepared by:** SGS Taiwan Ltd.  
No. 134, Wu Kung Rd., Wuku Industrial Zone,  
Taipei County, Taiwan.

*Note: This report shall not be reproduced except in full, without the written approval of SGS Taiwan Ltd. This document may be altered or revised by SGS Taiwan Ltd. personnel only, and shall be noted in the revision section of the document.*

Unless otherwise stated the results shown in this test report refer only to the sample(s) tested. This test report cannot be reproduced, except in full, without prior written permission of the Company. 除非另有說明，此報告結果僅對測試之樣品負責。本報告未經本公司書面許可，不可部份複製。

This Test Report is issued by the Company under its General Conditions of Service which is available on request or accessible at [http://www.sgs.com/terms\\_and\\_conditions.htm](http://www.sgs.com/terms_and_conditions.htm). Attention is drawn to the limitation of liability, indemnification and jurisdiction issues defined therein. Any holder of this Test Report is advised that information contained hereon reflects the Company's findings at the time of its intervention only and within the limits of Client's instructions, if any. The Company's sole responsibility is to its Client and this document does not exonerate parties to a transaction from exercising all their rights and obligations under the transaction documents. Any unauthorized alteration, forgery or falsification of the content or appearance of this document is unlawful and offenders may be prosecuted to the fullest extent of the law.

## VERIFICATION OF COMPLIANCE

**Applicant:** TCT Mobile Suzhou Limited  
 3/F,B2 Block,Digital Technology Yard, Gaoxin Nan Qi Road,Nan Shan  
 District, Shenzhen,Guangdong,P.R.China

**Equipment Under Test:** GSM850/PCS1900 mobile phone

**FCC ID Number:** RAD077

**Brand Name:** ALCATEL

**Model No:** U81CA

**Market name:** OT-S210A

**Model Difference:** N/A

**File Number:** ER/2008/40033



**Date of test:** Apr.11, 2008 ~ Aug. 04 , 2008

**Date of EUT Received:** Apr.10 , 2008

**We hereby certify that:**

The above equipment was tested by SGS Taiwan Ltd. The test data, data evaluation, test procedures, and equipment configurations shown in this report were made in accordance with the procedures given in TIA/EIA-603-C-2004 and the energy emitted by the sample EUT tested as described in this report is in compliance with conducted and radiated emission limits of FCC Rule FCC PART 22 subpart H and FCC PART 24 subpart E.

The test results of this report relate only to the tested sample identified in this report.

<b>Test By:</b>		<b>Date</b>	<b>Aug. 04, 2008</b>
	_____ <i>Jim Chang / Supervisor</i>		
<b>Prepared By:</b>		<b>Date</b>	<b>Aug. 04, 2008</b>
	_____ <i>Bondi Liu / Engineer</i>		
<b>Approved By:</b>		<b>Date</b>	<b>Aug. 04, 2008</b>
	_____ <i>Vincent Su / Manager</i>		

Unless otherwise stated the results shown in this test report refer only to the sample(s) tested. This test report cannot be reproduced, except in full, without prior written permission of the Company. 除非另有說明，此報告結果僅對測試之樣品負責。本報告未經本公司書面許可，不可部份複製。  
 This Test Report is issued by the Company under its General Conditions of Service which is available on request or accessible at [http://www.sgs.com/terms\\_and\\_conditions.htm](http://www.sgs.com/terms_and_conditions.htm). Attention is drawn to the limitation of liability, indemnification and jurisdiction issues defined therein. Any holder of this Test Report is advised that information contained hereon reflects the Company's findings at the time of its intervention only and within the limits of Client's instructions, if any. The Company's sole responsibility is to its Client and this document does not exonerate parties to a transaction from exercising all their rights and obligations under the transaction documents. Any unauthorized alteration, forgery or falsification of the content or appearance of this document is unlawful and offenders may be prosecuted to the fullest extent of the law.

## Version

Version No.	Date	Description
1.0	Aug. 04, 2008	Testing conducted emissions upto20GHz for PCS bands.

Unless otherwise stated the results shown in this test report refer only to the sample(s) tested. This test report cannot be reproduced, except in full, without prior written permission of the Company. 除非另有說明，此報告結果僅對測試之樣品負責。本報告未經本公司書面許可，不可部份複製。

This Test Report is issued by the Company under its General Conditions of Service which is available on request or accessible at [http://www.sgs.com/terms\\_and\\_conditions.htm](http://www.sgs.com/terms_and_conditions.htm). Attention is drawn to the limitation of liability, indemnification and jurisdiction issues defined therein. Any holder of this Test Report is advised that information contained hereon reflects the Company's findings at the time of its intervention only and within the limits of Client's instructions, if any. The Company's sole responsibility is to its Client and this document does not exonerate parties to a transaction from exercising all their rights and obligations under the transaction documents. Any unauthorized alteration, forgery or falsification of the content or appearance of this document is unlawful and offenders may be prosecuted to the fullest extent of the law.

## Table of Contents

<b>1</b>	<b>GENERAL INFORMATION .....</b>	<b>6</b>
1.1	Related Submittal(s) / Grant (s) .....	7
1.2	Test Methodology .....	7
1.3	Test Facility.....	7
1.4	Special Accessories.....	7
1.5	Equipment Modifications.....	7
<b>2</b>	<b>SYSTEM TEST CONFIGURATION .....</b>	<b>8</b>
2.1	EUT Configuration .....	8
2.2	EUT Exercise .....	8
2.3	Test Procedure.....	8
2.4	Configuration of Tested System.....	9
<b>3</b>	<b>SUMMARY OF TEST RESULTS .....</b>	<b>10</b>
<b>4</b>	<b>DESCRIPTION OF TEST MODES .....</b>	<b>10</b>
<b>5</b>	<b>RF POWER OUTPUT MEASUREMENT .....</b>	<b>11</b>
5.1	Standard Applicable .....	11
5.2	Test Set-up: .....	11
5.3	Measurement Procedure.....	11
5.4	Measurement Equipment Used: .....	12
5.5	Measurement Result.....	12
<b>6</b>	<b>ERP, EIRP MEASUREMENT .....</b>	<b>13</b>
6.1	Standard Applicable .....	13
6.2	Test SET-UP (Block Diagram of Configuration) .....	13
6.3	Measurement Procedure.....	15
6.4	Measurement Equipment Used: .....	16
6.5	Measurement Result.....	17
6.6	Measurement Result.....	18
<b>7</b>	<b>99% OCCUPIED BANDWIDTH MEASUREMENT.....</b>	<b>19</b>
7.1	Standard Applicable .....	19
7.2	Test Set-up: .....	19
7.3	Measurement Procedure.....	19
7.4	Measurement Equipment Used: .....	20
7.5	Measurement Result: .....	20

Unless otherwise stated the results shown in this test report refer only to the sample(s) tested. This test report cannot be reproduced, except in full, without prior written permission of the Company. 除非另有說明，此報告結果僅對測試之樣品負責。本報告未經本公司書面許可，不可部份複製。

This Test Report is issued by the Company under its General Conditions of Service which is available on request or accessible at [http://www.sgs.com/terms\\_and\\_conditions.htm](http://www.sgs.com/terms_and_conditions.htm). Attention is drawn to the limitation of liability, indemnification and jurisdiction issues defined therein. Any holder of this Test Report is advised that information contained hereon reflects the Company's findings at the time of its intervention only and within the limits of Client's instructions, if any. The Company's sole responsibility is to its Client and this document does not exonerate parties to a transaction from exercising all their rights and obligations under the transaction documents. Any unauthorized alteration, forgery or falsification of the content or appearance of this document is unlawful and offenders may be prosecuted to the fullest extent of the law.

**8 OUT OF BAND EMISSION AT ANTENNA TERMINALS ..... 25**

8.1 Standard Applicable ..... 25

8.2 Test SET-UP..... 25

8.3 Measurement Procedure..... 25

8.4 Measurement Equipment Used: ..... 26

8.5 Measurement Result..... 27

**9 FIELD STRENGTH OF SPURIOUS RADIATION MEASUREMENT ..... 35**

9.1 Standard Applicable ..... 35

9.2 EUT Setup (Block Diagram of Configuration)..... 35

9.3 Measurement Procedure..... 37

9.4 Measurement Equipment Used: ..... 38

9.5 Measurement Result..... 38

**10 FREQUENCY STABILITY V.S. TEMPERATURE MEASUREMENT ..... 51**

10.1 Standard Applicable ..... 51

10.2 Test Set-up: ..... 51

10.3 Measurement Procedure..... 51

10.4 Measurement Equipment Used: ..... 52

10.5 Measurement Result..... 53

**11 FREQUENCY STABILITY V.S. VOLTAGE MEASUREMENT ..... 54**

11.1 Standard Applicable ..... 54

11.2 Test Set-up: ..... 54

11.3 Measurement Procedure..... 54

11.4 Measurement Equipment Used: ..... 55

11.5 Measurement Result..... 56

**12 AC POWER LINE CONDUCTED EMISSION TEST ..... 57**

12.1 Standard Applicable ..... 57

12.2 EUT Setup..... 57

12.3 Measurement Procedure..... 57

12.4 Measurement Equipment Used: ..... 58

12.5 Measurement Result..... 58

Unless otherwise stated the results shown in this test report refer only to the sample(s) tested. This test report cannot be reproduced, except in full, without prior written permission of the Company. 除非另有說明，此報告結果僅對測試之樣品負責。本報告未經本公司書面許可，不可部份複製。

This Test Report is issued by the Company under its General Conditions of Service which is available on request or accessible at [http://www.sgs.com/terms\\_and\\_conditions.htm](http://www.sgs.com/terms_and_conditions.htm). Attention is drawn to the limitation of liability, indemnification and jurisdiction issues defined therein. Any holder of this Test Report is advised that information contained hereon reflects the Company's findings at the time of its intervention only and within the limits of Client's instructions, if any. The Company's sole responsibility is to its Client and this document does not exonerate parties to a transaction from exercising all their rights and obligations under the transaction documents. Any unauthorized alteration, forgery or falsification of the content or appearance of this document is unlawful and offenders may be prosecuted to the fullest extent of the law.

# 1 GENERAL INFORMATION

## Product Description

Product Name:	GSM850/PCS1900 mobile phone	
Model Name:	U81CA	
Market name:	OT-S210A	
Model Difference:	N/A	
Brand Name:	ALCATEL	
Power Supply:	Two 3.7 Vdc re-chargeable battery and two 5Vdc by AC/DC power adaptors	
	Battery Model:	CAB2001010C1, Supplier: BYD; CAB2001010C2, Supplier: Coslight
	Adapter Model:	T5002684AGAB, Supplier: SCUD; T5002684AGAA, Supplier: TENPAO

## GSM:

Frequency Range and Power	GSM 850: 824MHz –849MHz	33 dBm
	GSM 1900: 1850MHz –1910MHz	30 dBm
Type of Emission:	GSM 850 :246KGXW , GSM 1900 :249KGXW	
Software Version:	040	
Hardware Version:	PIO4	
IMEI:	011453-00-001381-1	

Unless otherwise stated the results shown in this test report refer only to the sample(s) tested. This test report cannot be reproduced, except in full, without prior written permission of the Company. 除非另有說明，此報告結果僅對測試之樣品負責。本報告未經本公司書面許可，不可部份複製。  
 This Test Report is issued by the Company under its General Conditions of Service which is available on request or accessible at [http://www.sgs.com/terms\\_and\\_conditions.htm](http://www.sgs.com/terms_and_conditions.htm). Attention is drawn to the limitation of liability, indemnification and jurisdiction issues defined therein. Any holder of this Test Report is advised that information contained hereon reflects the Company's findings at the time of its intervention only and within the limits of Client's instructions, if any. The Company's sole responsibility is to its Client and this document does not exonerate parties to a transaction from exercising all their rights and obligations under the transaction documents. Any unauthorized alteration, forgery or falsification of the content or appearance of this document is unlawful and offenders may be prosecuted to the fullest extent of the law.

### 1.21.1 Related Submittal(s) / Grant (s)

This submittal(s) (test report) is intended for FCC ID: **RAD077** filing to comply with Section Part 22 subpart H and Part 24 subpart E of the FCC CFR 47 Rules.

### 1.31.2 Test Methodology

Both conducted and radiated testing were performed according to the procedures document on FCC CFR 47 2.1046, 2.1049, 2.1051, 2.1053, 2.1055 and 2.1057.

### 1.41.3 Test Facility

The measurement facilities used to collect the 3m Radiated Emission and AC power line conducted data are located on the address of SGS Taiwan Ltd. Electronics & Communication Laboratory No. 134, Wu Kung Rd., Wuku Industrial Zone, Taipei Country, Taiwan which are constructed and calibrated to meet the FCC requirements in documents ANSI C63.4: 2003. FCC Registration Number are: 990257 and 236194, Canada Registration Number: 4620A-1

The 10 m Open Area Test Sites located on the address of SGS Taiwan Ltd. Electronics & Communication Laboratory No. 29, Pau-Tou-Tsuo Valley Chia-Pau Tsuen, Linkou Hsiang, Taipei county, which is constructed and calibrated to meet the CISPR 22/EN 55022 requirements. SGS Site No. 1(3 &10 meters) and FCC Registration Number: 94644.

### 1.51.4 Special Accessories

Not available for this EUT intended for grant.

### 1.61.5 Equipment Modifications

Not available for this EUT intended for grant.

Unless otherwise stated the results shown in this test report refer only to the sample(s) tested. This test report cannot be reproduced, except in full, without prior written permission of the Company. 除非另有說明，此報告結果僅對測試之樣品負責。本報告未經本公司書面許可，不可部份複製。

This Test Report is issued by the Company under its General Conditions of Service which is available on request or accessible at [http://www.sgs.com/terms\\_and\\_conditions.htm](http://www.sgs.com/terms_and_conditions.htm). Attention is drawn to the limitation of liability, indemnification and jurisdiction issues defined therein. Any holder of this Test Report is advised that information contained hereon reflects the Company's findings at the time of its intervention only and within the limits of Client's instructions, if any. The Company's sole responsibility is to its Client and this document does not exonerate parties to a transaction from exercising all their rights and obligations under the transaction documents. Any unauthorized alteration, forgery or falsification of the content or appearance of this document is unlawful and offenders may be prosecuted to the fullest extent of the law.

SGS Taiwan Ltd. | No. 134, Wu Kung Rd., Wuku Industrial Zone, Taipei Country, Taiwan. / 台北縣五股工業區五工路134號  
台灣檢驗科技股份有限公司 | t (886-2) 2299-3939 | f (886-2) 2299-3279 | [www.sgs.com.tw](http://www.sgs.com.tw)

Member of SGS Group

## 2.2 SYSTEM TEST CONFIGURATION

### 2.1 EUT Configuration

The EUT configuration for testing is installed on RF field strength measurement to meet the Commissions requirement and operating in a manner which intends to maximize its emission characteristics in a continuous normal application.

### 2.2 EUT Exercise

The EUT (Transmitter) was operated in the engineering mode to fix the Tx frequency which was for the purpose of the measurements.

### 2.3 Test Procedure

#### 2.3.1 AC Power Line Conducted Emissions

The EUT is placed on a turn table which is 0.8 m above ground plane. According to the requirements in Section 7 and 13 of ANSI C63.4-2003. Conducted emissions from the EUT measured in the frequency range between 0.15 MHz and 30MHz using CISPR Quasi-Peak and Average detector mode.

#### 2.3.2 Conducted Measurement at Antenna Port:

According to measurement procured TIA/EIA 603C, the EUT is placed on a turn table which is 0.8 m above ground plane. A low loss of RF cable was used to connect the antenna port of EUT to measurement equipment

#### 2.3.3 Radiated Emissions (ERP/EIRP):

According to measurement procured TIA/EIA 603C. The EUT is placed on a turn table which is 1.0 m above ground plane. The turn table shall rotate 360 degrees to determine the position of maximum emission level. EUT is set 3m away from the receiving antenna which varied from 1m to 4m to find out the highest emission. And also, each emission was to be maximized by changing the polarization of receiving antenna both horizontal and vertical. In order to find out the max. emission, the relative positions of this hand-held transmitter (EUT) was rotated through three orthogonal axes according to the requirements.

A standard antenna was used to replace the EUT and connect to the SG. Adjust the SG output level to reach the max emission level which were measured above.

Unless otherwise stated the results shown in this test report refer only to the sample(s) tested. This test report cannot be reproduced, except in full, without prior written permission of the Company. 除非另有說明，此報告結果僅對測試之樣品負責。本報告未經本公司書面許可，不可部份複製。

This Test Report is issued by the Company under its General Conditions of Service which is available on request or accessible at [http://www.sgs.com/terms\\_and\\_conditions.htm](http://www.sgs.com/terms_and_conditions.htm). Attention is drawn to the limitation of liability, indemnification and jurisdiction issues defined therein. Any holder of this Test Report is advised that information contained hereon reflects the Company's findings at the time of its intervention only and within the limits of Client's instructions, if any. The Company's sole responsibility is to its Client and this document does not exonerate parties to a transaction from exercising all their rights and obligations under the transaction documents. Any unauthorized alteration, forgery or falsification of the content or appearance of this document is unlawful and offenders may be prosecuted to the fullest extent of the law.



## 2.4 Configuration of Tested System

Fig. 2-1 Configuration of Tested System (Fixed Channel)

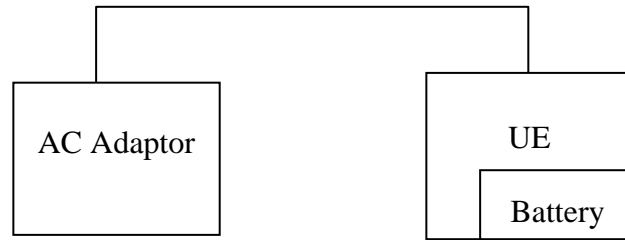

### Remote side

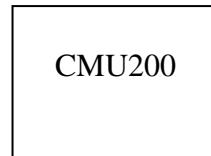

Table 2-1 Equipment Used in Tested System

Item	Equipment	Mfr/Brand	Model/ Type No.	Series No.	Data Cable	Power Cord
1	Universal Radio Communication Tester	R&S	CMU200	102189	shielded	Un-shielded

Unless otherwise stated the results shown in this test report refer only to the sample(s) tested. This test report cannot be reproduced, except in full, without prior written permission of the Company. 除非另有說明，此報告結果僅對測試之樣品負責。本報告未經本公司書面許可，不可部份複製。

This Test Report is issued by the Company under its General Conditions of Service which is available on request or accessible at [http://www.sgs.com/terms\\_and\\_conditions.htm](http://www.sgs.com/terms_and_conditions.htm). Attention is drawn to the limitation of liability, indemnification and jurisdiction issues defined therein. Any holder of this Test Report is advised that information contained hereon reflects the Company's findings at the time of its intervention only and within the limits of Client's instructions, if any. The Company's sole responsibility is to its Client and this document does not exonerate parties to a transaction from exercising all their rights and obligations under the transaction documents. Any unauthorized alteration, forgery or falsification of the content or appearance of this document is unlawful and offenders may be prosecuted to the fullest extent of the law.

### 3.3 SUMMARY OF TEST RESULTS

FCC Rules	Description Of Test	Result
§2.1046(a) §22.913(a) §24.232(a)	RF Power Output	Compliant
§2.1046(a) §22.913(a) §24.232(a)	ERP/ EIRP measurement	Compliant
§2.1049(h)	99% Occupied Bandwidth	Compliant
§2.1051 §22.917(a) §24.238(a)	Out of Band Emissions at Antenna Terminals and Band Edge	Compliant
§2.1053 §22.917(a) §24.238(a)	Field Strength of Spurious Radiation	Compliant
§2.1055(a)(1)(b)	Frequency Stability vs. Temperature	Compliant
§2.1055(d)(1)(2)	Frequency Stability vs. Voltage	Compliant
§15.107;§15.207	AC Power Line Conducted Emission	Compliant

### 4.4 DESCRIPTION OF TEST MODES

The EUT has been tested under operating condition.

EUT staying in continuous transmitting mode. Channel Low, Mid and High for each type band with rated data rate were chosen for full testing.

The field strength of spurious radiation emission was measured as EUT stand-up position (H mode) and lie down position (E1, E2 mode) for GSM with all power adaptors and earphone. The worst-case E2 mode for GSM 850 band and E1 mode for GSM 1900 band with adaptor for channel Low, Mid and High at GSM mode was reported.

All tests were carried out for worst adaptor: T5002684AGAB

Unless otherwise stated the results shown in this test report refer only to the sample(s) tested. This test report cannot be reproduced, except in full, without prior written permission of the Company. 除非另有說明，此報告結果僅對測試之樣品負責。本報告未經本公司書面許可，不可部份複製。  
 This Test Report is issued by the Company under its General Conditions of Service which is available on request or accessible at [http://www.sgs.com/terms\\_and\\_conditions.htm](http://www.sgs.com/terms_and_conditions.htm). Attention is drawn to the limitation of liability, indemnification and jurisdiction issues defined therein. Any holder of this Test Report is advised that information contained hereon reflects the Company's findings at the time of its intervention only and within the limits of Client's instructions, if any. The Company's sole responsibility is to its Client and this document does not exonerate parties to a transaction from exercising all their rights and obligations under the transaction documents. Any unauthorized alteration, forgery or falsification of the content or appearance of this document is unlawful and offenders may be prosecuted to the fullest extent of the law.

## 5.5 RF POWER OUTPUT MEASUREMENT

### 5.1 Standard Applicable

According to FCC §2.1046.

FCC 22.913(a) Mobile station are limited to 7W.

FCC 24.232(b) Mobile station are limited to 2W.

### 5.2 Test Set-up:

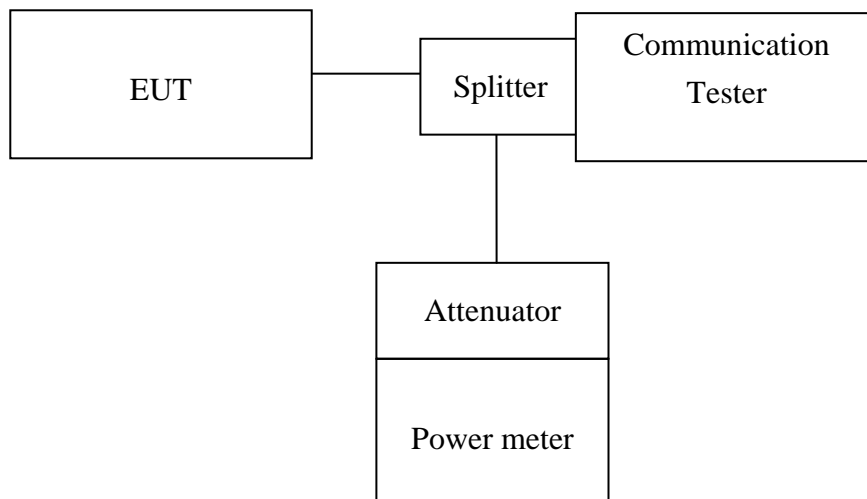

*Note: Measurement setup for testing on Antenna connector*

### 5.3 Measurement Procedure

The transmitter output was connected to a calibrated attenuator, the other end of which was connected to a power meter. Transmitter output was read off the power meter in dBm. The power output at the transmitter antenna port was determined by adding the value of the attenuator to the power meter reading.

Unless otherwise stated the results shown in this test report refer only to the sample(s) tested. This test report cannot be reproduced, except in full, without prior written permission of the Company. 除非另有說明，此報告結果僅對測試之樣品負責。本報告未經本公司書面許可，不可部份複製。

This Test Report is issued by the Company under its General Conditions of Service which is available on request or accessible at [http://www.sgs.com/terms\\_and\\_conditions.htm](http://www.sgs.com/terms_and_conditions.htm). Attention is drawn to the limitation of liability, indemnification and jurisdiction issues defined therein. Any holder of this Test Report is advised that information contained hereon reflects the Company's findings at the time of its intervention only and within the limits of Client's instructions, if any. The Company's sole responsibility is to its Client and this document does not exonerate parties to a transaction from exercising all their rights and obligations under the transaction documents. Any unauthorized alteration, forgery or falsification of the content or appearance of this document is unlawful and offenders may be prosecuted to the fullest extent of the law.

### 5.4 Measurement Equipment Used:

Conducted Emission Test Site					
EQUIPMENT TYPE	MFR	MODEL NUMBER	SERIAL NUMBER	LAST CAL.	CAL DUE.
Spectrum Analyzer	Agilent	E4446A	MY43360126	04/27/2008	04/26/2009
Spectrum Analyzer	Agilent	E7405A	US41160416	06/28/2008	06/29/2009
Spectrum Analyzer	R&S	FSP 40	100034	11/09/2007	11/10/2008
Communication Test	R&S	CMU200	N/A	N/A	N/A
Power Sensor	Anritsu	MA2490A	31431	06/28/2008	06/29/2009
Power Meter	Anritsu	ML2487A	6K00002070	06/28/2008	06/29/2009
Temperature Chamber	TERCHY	MHG-120LF	911009	10/14/2007	10/13/2008
Low Loss Cable	HUBER+SUHNER	SUCOFLEX 104PEA	N/A	N/A	N/A
Attenuator	Mini-Circuit	BW-S10W5	N/A	09/23/2007	09/22/2008
Attenuator	Mini-Circuit	BW-S6W5	N/A	09/23/2007	09/22/2008
Splitter	Agilent	11636B	51728	09/23/2007	09/22/2008
DC Power Supply	TOPWARD	3303A	N/A	N/A	N/A

### 5.5 Measurement Result

EUT Mode	Frequency (MHz)	CH	Power meter Reading (dBm)	Path Loss (dB)	Power (dBm)
GSM 850	824.20	128	13.24	17.50	30.74
	836.60	190	13.47	17.50	30.97
	848.80	251	13.32	17.50	30.82

EUT Mode	Frequency (MHz)	CH	Power Meter Reading (dBm)	Path Loss (dB)	Power (dBm)
PCS 1900	1850.20	512	11.38	17.50	28.88
	1880.00	661	11.47	17.50	28.97
	1909.80	810	11.54	17.50	29.04

Unless otherwise stated the results shown in this test report refer only to the sample(s) tested. This test report cannot be reproduced, except in full, without prior written permission of the Company. 除非另有說明，此報告結果僅對測試之樣品負責。本報告未經本公司書面許可，不可部份複製。  
 This Test Report is issued by the Company under its General Conditions of Service which is available on request or accessible at [http://www.sgs.com/terms\\_and\\_conditions.htm](http://www.sgs.com/terms_and_conditions.htm). Attention is drawn to the limitation of liability, indemnification and jurisdiction issues defined therein. Any holder of this Test Report is advised that information contained hereon reflects the Company's findings at the time of its intervention only and within the limits of Client's instructions, if any. The Company's sole responsibility is to its Client and this document does not exonerate parties to a transaction from exercising all their rights and obligations under the transaction documents. Any unauthorized alteration, forgery or falsification of the content or appearance of this document is unlawful and offenders may be prosecuted to the fullest extent of the law.

## 6.6 ERP, EIRP MEASUREMENT

### 6.1 Standard Applicable

According to FCC §2.1046

FCC 22.913(a) Mobile station are limited to 7W ERP.

FCC 24.232(b) Mobile station are limited to 2W EIRP.

### 6.2 Test SET-UP (Block Diagram of Configuration)

(A) Radiated Emission Test Set-Up, Frequency Below 1000MHz

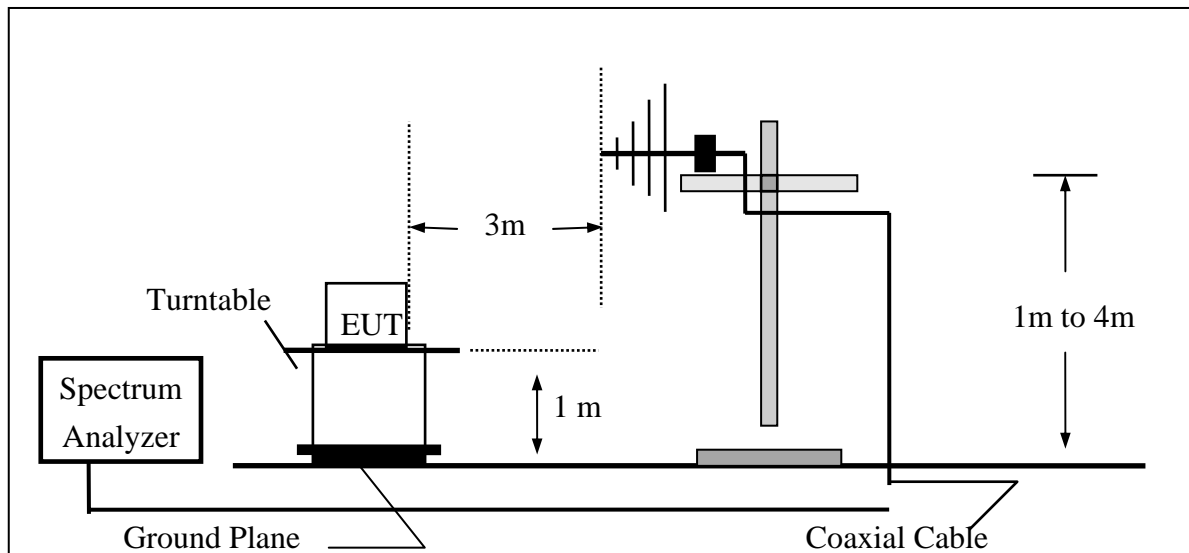

Unless otherwise stated the results shown in this test report refer only to the sample(s) tested. This test report cannot be reproduced, except in full, without prior written permission of the Company. 除非另有說明，此報告結果僅對測試之樣品負責。本報告未經本公司書面許可，不可部份複製。

This Test Report is issued by the Company under its General Conditions of Service which is available on request or accessible at [http://www.sgs.com/terms\\_and\\_conditions.htm](http://www.sgs.com/terms_and_conditions.htm). Attention is drawn to the limitation of liability, indemnification and jurisdiction issues defined therein. Any holder of this Test Report is advised that information contained hereon reflects the Company's findings at the time of its intervention only and within the limits of Client's instructions, if any. The Company's sole responsibility is to its Client and this document does not exonerate parties to a transaction from exercising all their rights and obligations under the transaction documents. Any unauthorized alteration, forgery or falsification of the content or appearance of this document is unlawful and offenders may be prosecuted to the fullest extent of the law.

(B) Radiated Emission Test Set-UP Frequency Over 1 GHz

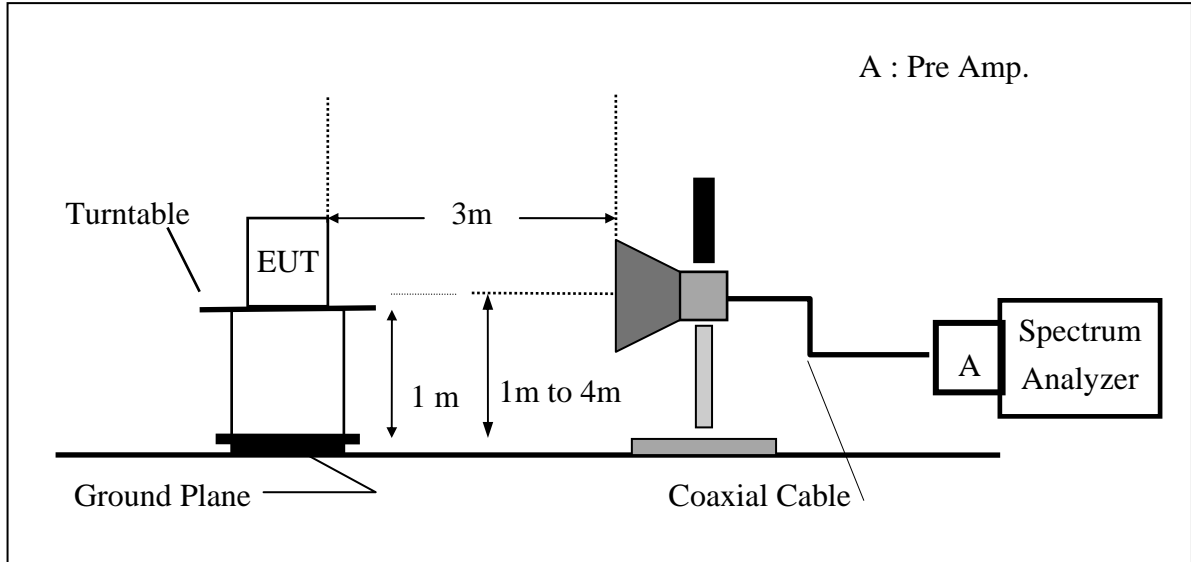

(C) Substituted Method Test Set-UP

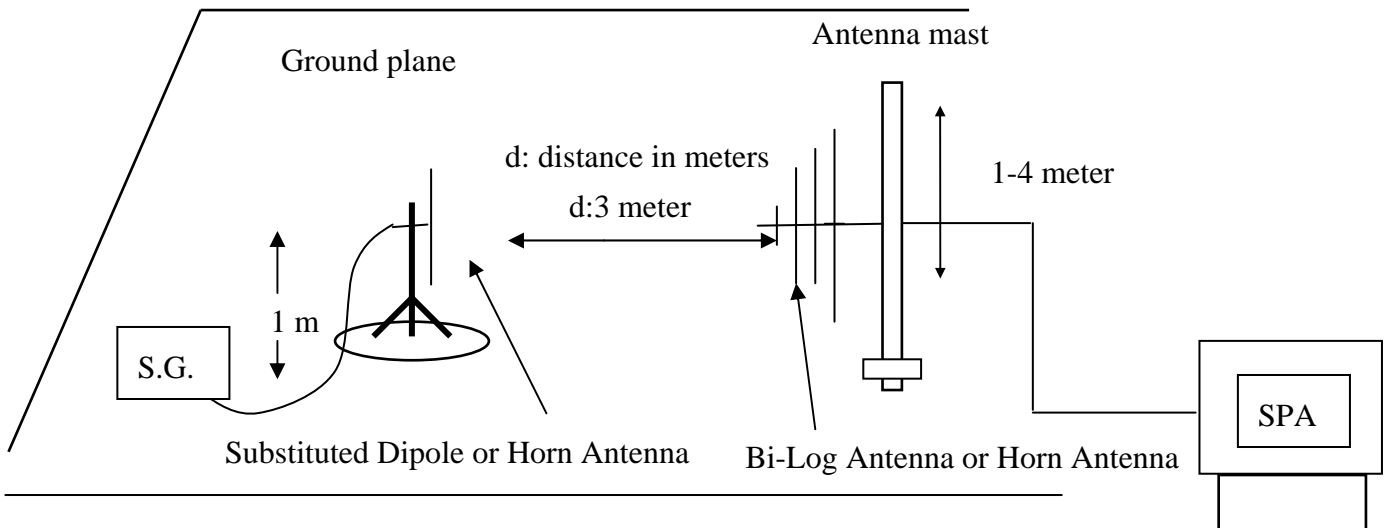

Unless otherwise stated the results shown in this test report refer only to the sample(s) tested. This test report cannot be reproduced, except in full, without prior written permission of the Company. 除非另有說明，此報告結果僅對測試之樣品負責。本報告未經本公司書面許可，不可部份複製。

This Test Report is issued by the Company under its General Conditions of Service which is available on request or accessible at [http://www.sgs.com/terms\\_and\\_conditions.htm](http://www.sgs.com/terms_and_conditions.htm). Attention is drawn to the limitation of liability, indemnification and jurisdiction issues defined therein. Any holder of this Test Report is advised that information contained hereon reflects the Company's findings at the time of its intervention only and within the limits of Client's instructions, if any. The Company's sole responsibility is to its Client and this document does not exonerate parties to a transaction from exercising all their rights and obligations under the transaction documents. Any unauthorized alteration, forgery or falsification of the content or appearance of this document is unlawful and offenders may be prosecuted to the fullest extent of the law.

### 6.3 Measurement Procedure

The EUT was placed on a non-conductive turntable using a non-conductive support. The radiated emission at the fundamental frequency was measured at 3 m with a test antenna and EMI spectrum analyzer.

During the measurement, the EUT was in communication with the station. The highest emission was recorded with the rotation of the turntable and the lowering of the test antenna from 4m to 1m. The reading was recorded and the field strength (E in dBuV/m) was calculated.

ERP in frequency band 824.2 –848.80.8MHz were measured using a substitution method. The EUT was replaced by a dipole antenna connected, the S.G. output was recorded and ERP was calculated as follows:

EIRP in frequency band 1850.2 –1909.8MHz were measured using a substitution method. The EUT was replaced by a horn antenna connected, the S.G. output was recorded and EIRP was calculated as follows:

$$\text{ERP} = \text{S.G. output (dBm)} + \text{Antenna Gain (dBd)} - \text{Cable Loss (dB)}$$

$$\text{EIRP} = \text{S.G. output (dBm)} + \text{Antenna Gain (dBi)} - \text{Cable Loss (dB)}$$

Unless otherwise stated the results shown in this test report refer only to the sample(s) tested. This test report cannot be reproduced, except in full, without prior written permission of the Company. 除非另有說明，此報告結果僅對測試之樣品負責。本報告未經本公司書面許可，不可部份複製。

This Test Report is issued by the Company under its General Conditions of Service which is available on request or accessible at [http://www.sgs.com/terms\\_and\\_conditions.htm](http://www.sgs.com/terms_and_conditions.htm). Attention is drawn to the limitation of liability, indemnification and jurisdiction issues defined therein. Any holder of this Test Report is advised that information contained hereon reflects the Company's findings at the time of its intervention only and within the limits of Client's instructions, if any. The Company's sole responsibility is to its Client and this document does not exonerate parties to a transaction from exercising all their rights and obligations under the transaction documents. Any unauthorized alteration, forgery or falsification of the content or appearance of this document is unlawful and offenders may be prosecuted to the fullest extent of the law.

**6.41.1 Measurement Equipment Used:**

EQUIPMENT TYPE	MFR	MODEL NUMBER	SERIAL NUMBER	LAST CAL.	CAL DUE.
Spectrum Analyzer	Agilent	E4446A	MY43360126	04/27/2008	04/26/2009
Spectrum Analyzer	Agilent	7405A	US41160416	06/28/2008	06/29/2009
Spectrum Analyzer	R&S	FSP 40	100034	11/09/2007	11/10/2008
Communication Test	R&S	CMU200	N/A	N/A	N/A
Bi-log Antenna	SCHWAZBECK	VULB9160	3224	11/14/2007	13/11/2008
Horn antenna	SCHWAZBECK	BBHA 9120D	309/320	08/16/2008	08/15/2009
Pre-Amplifier	HP	8447D	2944A09469	07/19/2008	07/18/2009
Pre-Amplifier	HP	8494B	3008A00578	02/26/2008	02/25/2009
Signal Generator	R&S	SMR40	100210	02/09/2008	02/10/2009
Turn Table	HD	DT420	N/A	N.C.R	N.C.R
Antenna Tower	HD	MA240-N	240/657	N.C.R	N.C.R
Controller	HD	HD100	N/A	N.C.R	N.C.R
Low Loss Cable	HUBER+SUHNER	SUCOFLEX 104PEA-10M	10m	10/09/2007	10/08/2008
Low Loss Cable	HUBER+SUHNER	SUCOFLEX 104PEA-3M	3m	10/09/2007	10/08/2008
Low Loss Cable	HUBER+SUHNER	SUCOFLEX 104PEA-0.5M	0.5m	10/09/2007	10/08/2008
Site NSA	SGS	966 chamber	N/A	11/17/2007	11/16/2008
Attenuator	Mini-Circuit	BW-S10W5	N/A	09/23/2007	09/22/2008
Dipole Antenna	SCHWAZBECK	VHAP	908/909	06/10/2008	06/11/2009
Dipole Antenna	SCHWAZBECK	UHAP	891/892	06/10/2008	06/11/2009
Horn antenna	SCHWAZBECK	BBHA 9120D	N/A	08/16/2007	08/15/2008

Unless otherwise stated the results shown in this test report refer only to the sample(s) tested. This test report cannot be reproduced, except in full, without prior written permission of the Company. 除非另有說明，此報告結果僅對測試之樣品負責。本報告未經本公司書面許可，不可部份複製。  
 This Test Report is issued by the Company under its General Conditions of Service which is available on request or accessible at [http://www.sgs.com/terms\\_and\\_conditions.htm](http://www.sgs.com/terms_and_conditions.htm). Attention is drawn to the limitation of liability, indemnification and jurisdiction issues defined therein. Any holder of this Test Report is advised that information contained hereon reflects the Company's findings at the time of its intervention only and within the limits of Client's instructions, if any. The Company's sole responsibility is to its Client and this document does not exonerate parties to a transaction from exercising all their rights and obligations under the transaction documents. Any unauthorized alteration, forgery or falsification of the content or appearance of this document is unlawful and offenders may be prosecuted to the fullest extent of the law.



6.56.4 Measurement Result

EUT Mode	Frequency (MHz)	CH	EUT Pol.	Antenna Pol.	SPA Reading (dBuV)	S.G. Output (dBm)	Antenna Gain (dBd)	Cable Loss (dB)	ERP (dBm)	Limit (dBm)
GSM 850	824.20	128	H	V	124.75	38.36	-7.87	3.62	26.86	38.45
				H	124.26	37.99	-7.87	3.62	26.49	38.45
			E1	V	125.14	38.75	-7.87	3.62	27.25	38.45
				H	125.33	39.06	-7.87	3.62	27.56	38.45
			E2	V	128.77	42.38	-7.87	3.62	30.88	38.45
				H	128.94	42.67	-7.87	3.62	31.17	38.45
	836.60	190	H	V	122.95	36.70	-7.88	3.65	25.17	38.45
				H	122.87	36.64	-7.88	3.65	25.11	38.45
			E1	V	125.67	39.42	-7.88	3.65	27.89	38.45
				H	125.72	39.49	-7.88	3.65	27.96	38.45
			E2	V	129.57	43.32	-7.88	3.65	31.79	38.45
				H	129.66	43.43	-7.88	3.65	31.90	38.45
	848.80	251	H	V	122.20	36.08	-7.88	3.68	24.52	38.45
				H	122.06	35.87	-7.88	3.68	24.31	38.45
			E1	V	124.62	38.50	-7.88	3.68	26.94	38.45
				H	124.49	38.30	-7.88	3.68	26.74	38.45
			E2	V	128.51	42.39	-7.88	3.68	30.83	38.45
				H	128.49	42.30	-7.88	3.68	30.74	38.45

Remark :

- (1) The RBW,VBW of SPA for frequency  
 Below 1GHz was RBW= 250 KHz, VBW=300KHz,  
 Above 1GHz was RBW= 1MHz , VBW= 3MHz

Unless otherwise stated the results shown in this test report refer only to the sample(s) tested. This test report cannot be reproduced, except in full, without prior written permission of the Company. 除非另有說明，此報告結果僅對測試之樣品負責。本報告未經本公司書面許可，不可部份複製。  
 This Test Report is issued by the Company under its General Conditions of Service which is available on request or accessible at [http://www.sgs.com/terms\\_and\\_conditions.htm](http://www.sgs.com/terms_and_conditions.htm). Attention is drawn to the limitation of liability, indemnification and jurisdiction issues defined therein. Any holder of this Test Report is advised that information contained hereon reflects the Company's findings at the time of its intervention only and within the limits of Client's instructions, if any. The Company's sole responsibility is to its Client and this document does not exonerate parties to a transaction from exercising all their rights and obligations under the transaction documents. Any unauthorized alteration, forgery or falsification of the content or appearance of this document is unlawful and offenders may be prosecuted to the fullest extent of the law.

### 6.5 Measurement Result

EUT Mode	Frequency (MHz)	CH	EUT Pol.	Antenna Pol.	SPA Reading (dBuV)	S.G. Output (dBm)	Antenna Gain (dBi)	Cable Loss (dB)	EIRP (dBm)	Limit (dBm)
PCS 1900	1850.20	512	H	V	124.63	20.24	9.90	5.56	24.58	33.00
				H	124.96	20.78	9.90	5.56	25.12	33.00
			E1	V	128.38	23.99	9.90	5.56	28.33	33.00
				H	128.30	24.12	9.90	5.56	28.46	33.00
			E2	V	127.60	23.21	9.90	5.56	27.55	33.00
				H	127.68	23.50	9.90	5.84	27.56	33.00
	1880.00	661	H	V	124.26	19.90	9.99	5.61	24.28	33.00
				H	124.31	20.17	9.99	5.61	24.54	33.00
			E1	V	128.31	23.95	9.99	5.61	28.33	33.00
				H	128.39	24.25	9.99	5.61	28.62	33.00
			E2	V	128.20	23.84	9.99	5.61	28.22	33.00
				H	128.15	24.01	9.99	5.61	28.38	33.00
	1909.80	810	H	V	124.51	20.18	10.08	5.66	24.60	33.00
				H	124.42	20.31	10.08	5.66	24.73	33.00
			E1	V	128.12	23.79	10.08	5.66	28.21	33.00
				H	128.09	23.98	10.08	5.66	28.40	33.00
			E2	V	128.12	23.79	10.08	5.66	28.21	33.00
				H	128.03	23.92	10.08	5.66	28.34	33.00

**Remark :**

- (1) The RBW,VBW of SPA for frequency  
 Below 1GHz was RBW= 250 KHz, VBW= 300KHz,  
 Above 1GHz was RBW= 1MHz , VBW= 3MHz

Unless otherwise stated the results shown in this test report refer only to the sample(s) tested. This test report cannot be reproduced, except in full, without prior written permission of the Company. 除非另有說明，此報告結果僅對測試之樣品負責。本報告未經本公司書面許可，不可部份複製。  
 This Test Report is issued by the Company under its General Conditions of Service which is available on request or accessible at [http://www.sgs.com/terms\\_and\\_conditions.htm](http://www.sgs.com/terms_and_conditions.htm). Attention is drawn to the limitation of liability, indemnification and jurisdiction issues defined therein. Any holder of this Test Report is advised that information contained hereon reflects the Company's findings at the time of its intervention only and within the limits of Client's instructions, if any. The Company's sole responsibility is to its Client and this document does not exonerate parties to a transaction from exercising all their rights and obligations under the transaction documents. Any unauthorized alteration, forgery or falsification of the content or appearance of this document is unlawful and offenders may be prosecuted to the fullest extent of the law.

## 7.7 99% OCCUPIED BANDWIDTH MEASUREMENT

### 7.1 Standard Applicable

According to §FCC 2.1049.

### 7.2 Test Set-up:

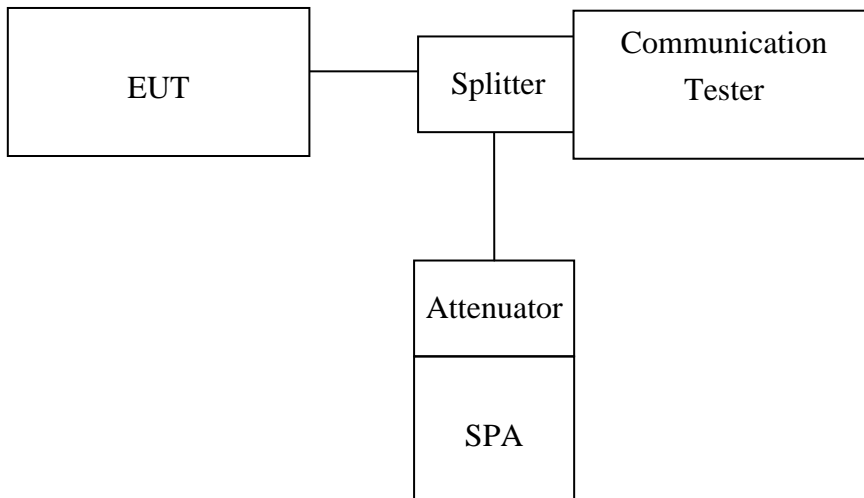

*Note: Measurement setup for testing on Antenna connector*

### 7.3 Measurement Procedure

The EUT's output RF connector was connected with a short cable to the spectrum analyzer, RBW (10/30KHz) was set to about 1% of emission BW, VBW= 3 times RBW(30/100KHz), -26dBc display line was placed on the screen (or 99% bandwidth), the occupied bandwidth is the delta frequency between the two points where the display line intersects the signal trace.

Unless otherwise stated the results shown in this test report refer only to the sample(s) tested. This test report cannot be reproduced, except in full, without prior written permission of the Company. 除非另有說明，此報告結果僅對測試之樣品負責。本報告未經本公司書面許可，不可部份複製。

This Test Report is issued by the Company under its General Conditions of Service which is available on request or accessible at [http://www.sgs.com/terms\\_and\\_conditions.htm](http://www.sgs.com/terms_and_conditions.htm). Attention is drawn to the limitation of liability, indemnification and jurisdiction issues defined therein. Any holder of this Test Report is advised that information contained hereon reflects the Company's findings at the time of its intervention only and within the limits of Client's instructions, if any. The Company's sole responsibility is to its Client and this document does not exonerate parties to a transaction from exercising all their rights and obligations under the transaction documents. Any unauthorized alteration, forgery or falsification of the content or appearance of this document is unlawful and offenders may be prosecuted to the fullest extent of the law.

### 7.4 Measurement Equipment Used:

Conducted Emission Test Site					
EQUIPMENT TYPE	MFR	MODEL NUMBER	SERIAL NUMBER	LAST CAL.	CAL DUE.
Spectrum Analyzer	Agilent	E4446A	MY43360126	04/27/2008	04/26/2009
Spectrum Analyzer	Agilent	7405A	US41160416	06/28/2008	06/29/2009
Power Sensor	Anritsu	MA2490A	31431	06/28/2008	06/29/2009
Power Meter	Anritsu	ML2487A	6K00002070	06/28/2008	06/29/2009
Temperature Chamber	TERCHY	MHG-120LF	911009	11/11/2007	11/12/2008
Low Loss Cable	HUBER+SUHNER	SUCOFLEX 104PEA	N/A	N/A	N/A
Attenuator	Mini-Circuit	BW-S10W5	N/A	10/07/2007	10/06/2008
Attenuator	Mini-Circuit	BW-S6W5	N/A	10/07/2007	10/06/2008
Splitter	Agilent	11636B	51728	09/23/2007	9/22/2008
Signal Generator	R&S	SMR40	100210	11/09/2007	11/10/2008
DC Power Supply	Agilent	6038A	2929A-07548	01/06/2008	01/05/2009

### 7.5 Measurement Result:.

EUT Mode	Frequency (MHz)	CH	99% Bandwidth (MHz)
GSM 850	824.20	128	0.2443
	836.60	190	0.2447
	848.80	251	0.2459

EUT Mode	Frequency (MHz)	CH	99% Bandwidth (MHz)
PCS 1900	1850.20	512	0.2457
	1880.00	661	0.2489
	1909.80	810	0.2456

Unless otherwise stated the results shown in this test report refer only to the sample(s) tested. This test report cannot be reproduced, except in full, without prior written permission of the Company. 除非另有說明，此報告結果僅對測試之樣品負責。本報告未經本公司書面許可，不可部份複製。  
 This Test Report is issued by the Company under its General Conditions of Service which is available on request or accessible at [http://www.sgs.com/terms\\_and\\_conditions.htm](http://www.sgs.com/terms_and_conditions.htm). Attention is drawn to the limitation of liability, indemnification and jurisdiction issues defined therein. Any holder of this Test Report is advised that information contained hereon reflects the Company's findings at the time of its intervention only and within the limits of Client's instructions, if any. The Company's sole responsibility is to its Client and this document does not exonerate parties to a transaction from exercising all their rights and obligations under the transaction documents. Any unauthorized alteration, forgery or falsification of the content or appearance of this document is unlawful and offenders may be prosecuted to the fullest extent of the law.

Figure 7-1: GSM Channel Low

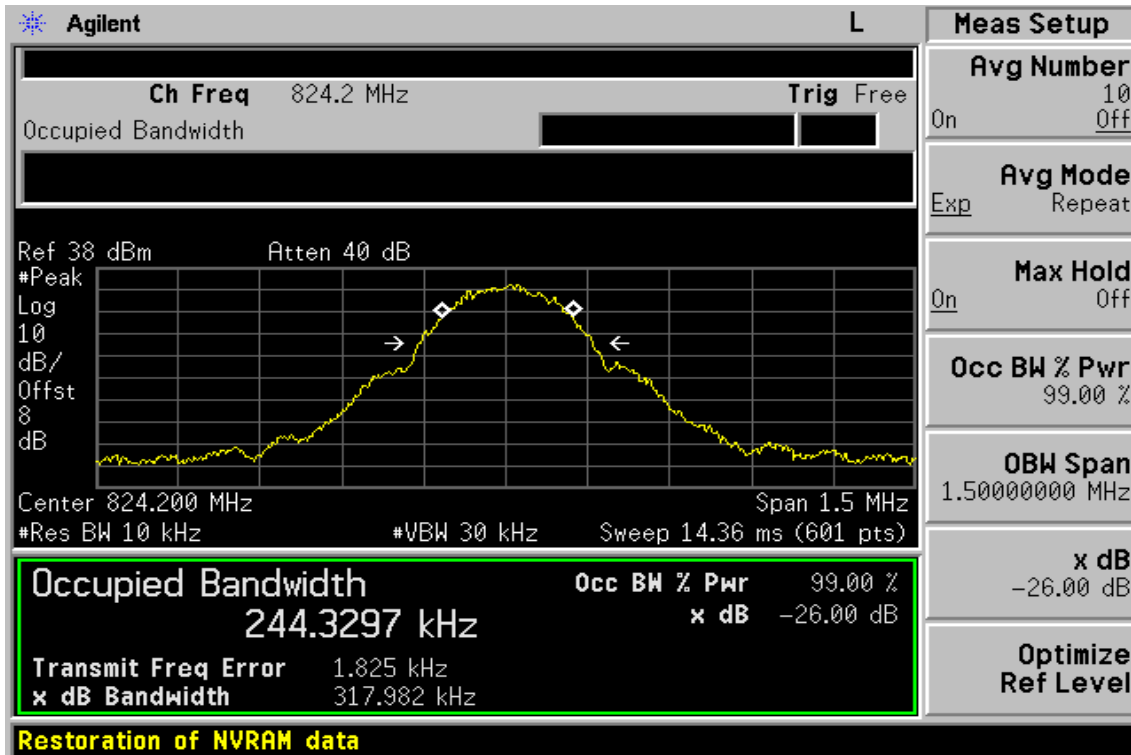
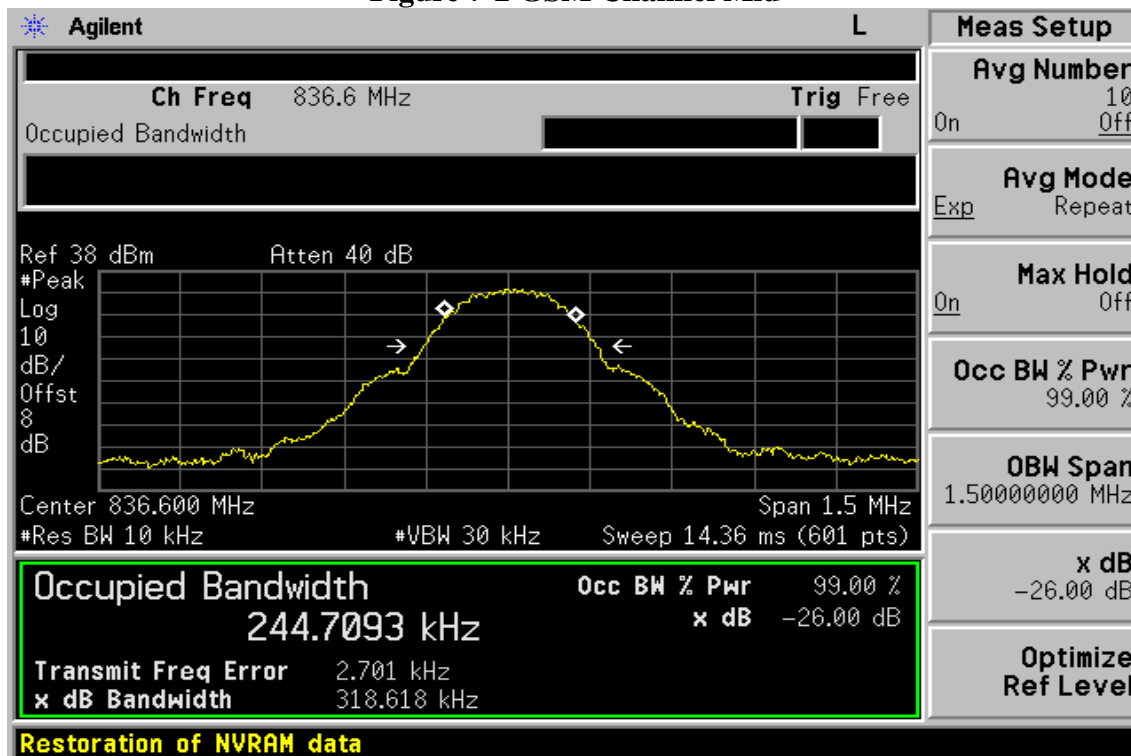

Figure 7-2 GSM Channel Mid



Unless otherwise stated the results shown in this test report refer only to the sample(s) tested. This test report cannot be reproduced, except in full, without prior written permission of the Company. 除非另有說明，此報告結果僅對測試之樣品負責。本報告未經本公司書面許可，不可部份複製。

This Test Report is issued by the Company under its General Conditions of Service which is available on request or accessible at [http://www.sgs.com/terms\\_and\\_conditions.htm](http://www.sgs.com/terms_and_conditions.htm). Attention is drawn to the limitation of liability, indemnification and jurisdiction issues defined therein. Any holder of this Test Report is advised that information contained hereon reflects the Company's findings at the time of its intervention only and within the limits of Client's instructions, if any. The Company's sole responsibility is to its Client and this document does not exonerate parties to a transaction from exercising all their rights and obligations under the transaction documents. Any unauthorized alteration, forgery or falsification of the content or appearance of this document is unlawful and offenders may be prosecuted to the fullest extent of the law.

Figure 7-3: GSM Channel High

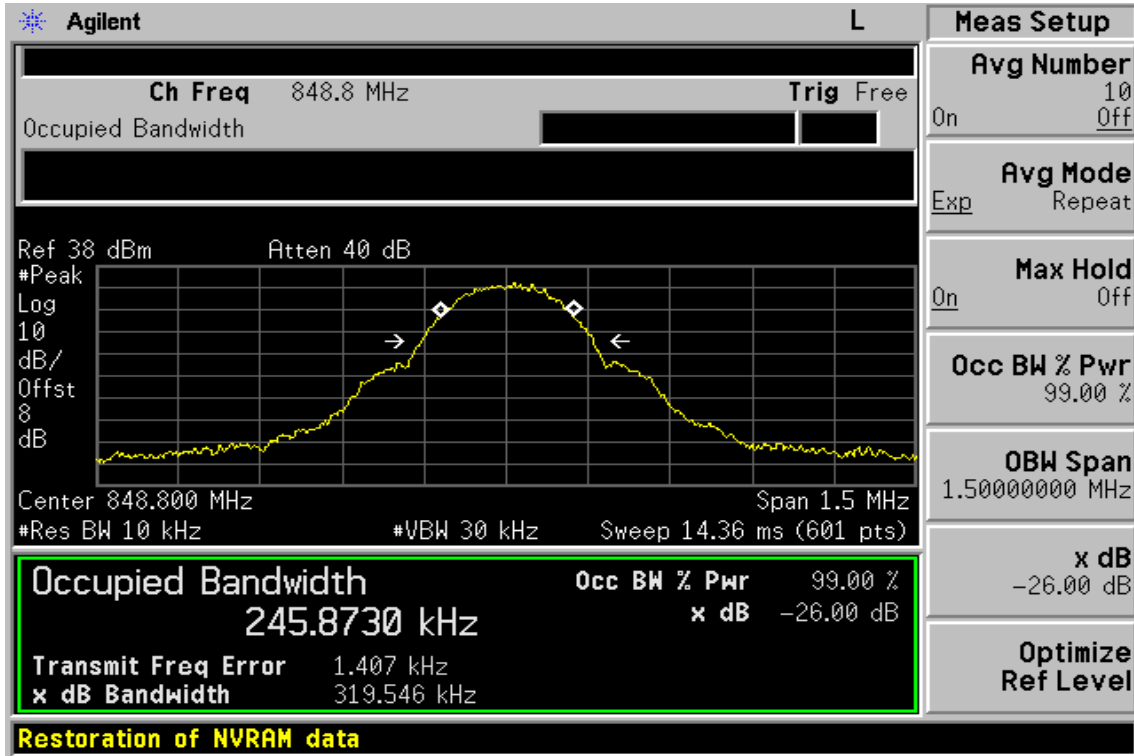

Unless otherwise stated the results shown in this test report refer only to the sample(s) tested. This test report cannot be reproduced, except in full, without prior written permission of the Company. 除非另有說明，此報告結果僅對測試之樣品負責。本報告未經本公司書面許可，不可部份複製。

This Test Report is issued by the Company under its General Conditions of Service which is available on request or accessible at [http://www.sgs.com/terms\\_and\\_conditions.htm](http://www.sgs.com/terms_and_conditions.htm). Attention is drawn to the limitation of liability, indemnification and jurisdiction issues defined therein. Any holder of this Test Report is advised that information contained hereon reflects the Company's findings at the time of its intervention only and within the limits of Client's instructions, if any. The Company's sole responsibility is to its Client and this document does not exonerate parties to a transaction from exercising all their rights and obligations under the transaction documents. Any unauthorized alteration, forgery or falsification of the content or appearance of this document is unlawful and offenders may be prosecuted to the fullest extent of the law.

Figure 7-4: PCS Channel Low

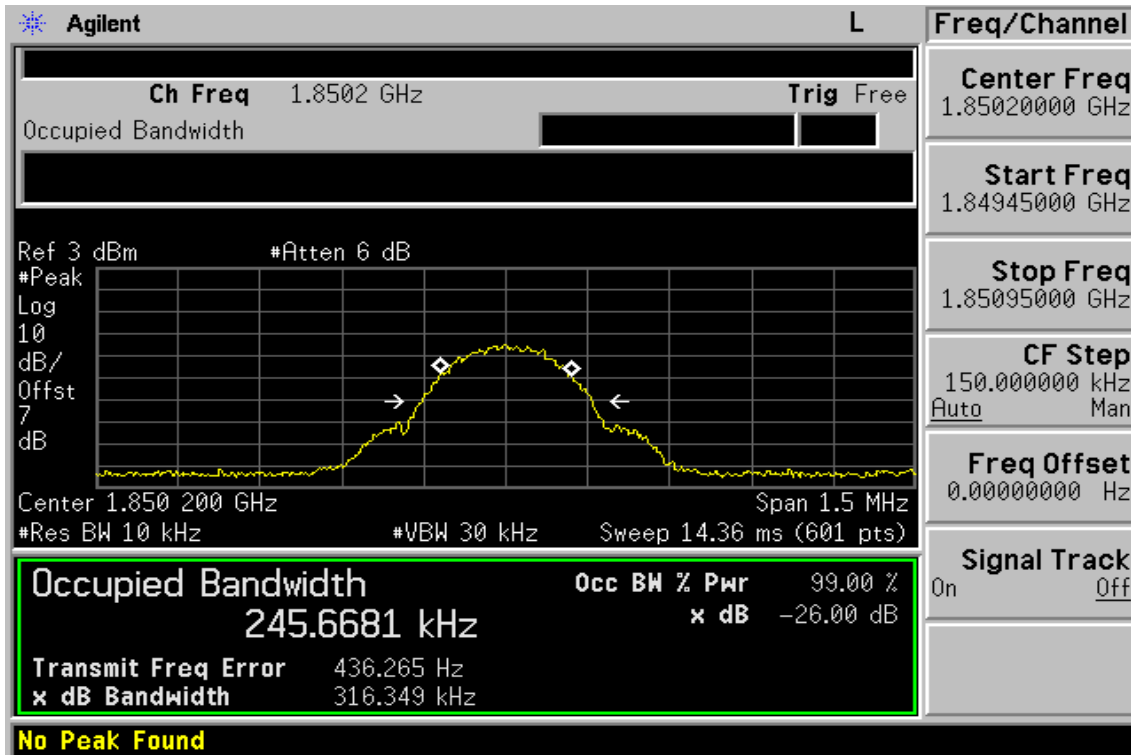
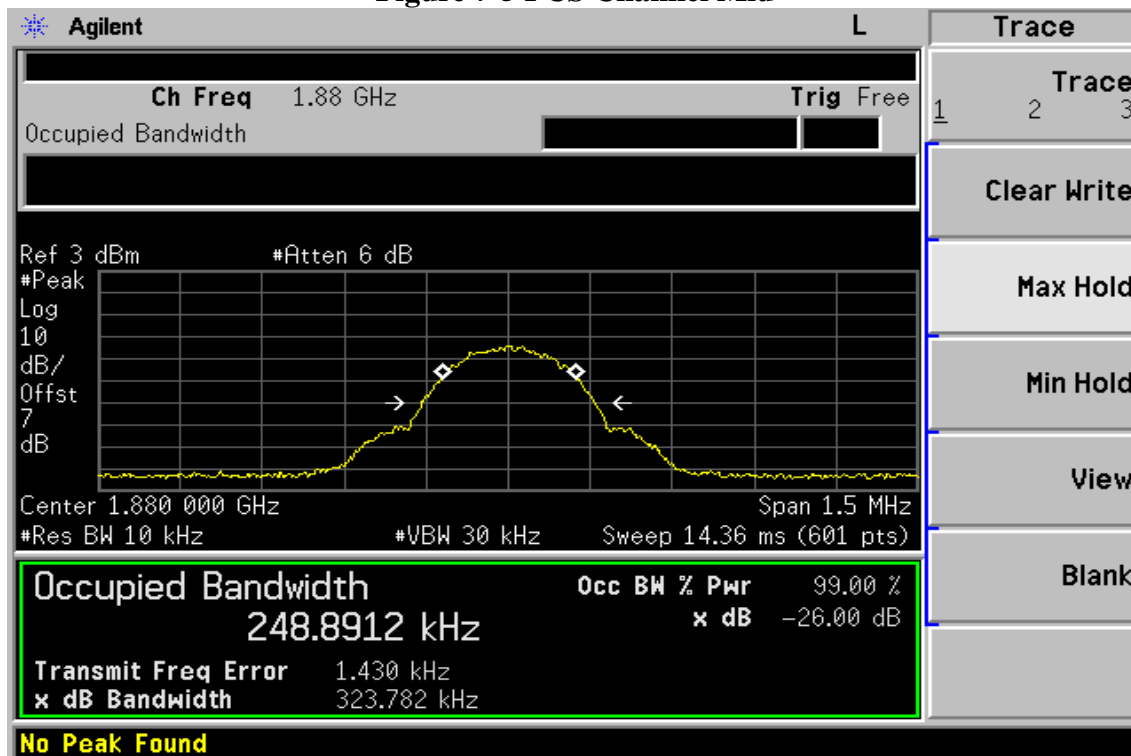

Figure 7-5: PCS Channel Mid



Unless otherwise stated the results shown in this test report refer only to the sample(s) tested. This test report cannot be reproduced, except in full, without prior written permission of the Company. 除非另有說明，此報告結果僅對測試之樣品負責。本報告未經本公司書面許可，不可部份複製。

This Test Report is issued by the Company under its General Conditions of Service which is available on request or accessible at [http://www.sgs.com/terms\\_and\\_conditions.htm](http://www.sgs.com/terms_and_conditions.htm). Attention is drawn to the limitation of liability, indemnification and jurisdiction issues defined therein. Any holder of this Test Report is advised that information contained hereon reflects the Company's findings at the time of its intervention only and within the limits of Client's instructions, if any. The Company's sole responsibility is to its Client and this document does not exonerate parties to a transaction from exercising all their rights and obligations under the transaction documents. Any unauthorized alteration, forgery or falsification of the content or appearance of this document is unlawful and offenders may be prosecuted to the fullest extent of the law.

Figure 7-6: PCS Channel High

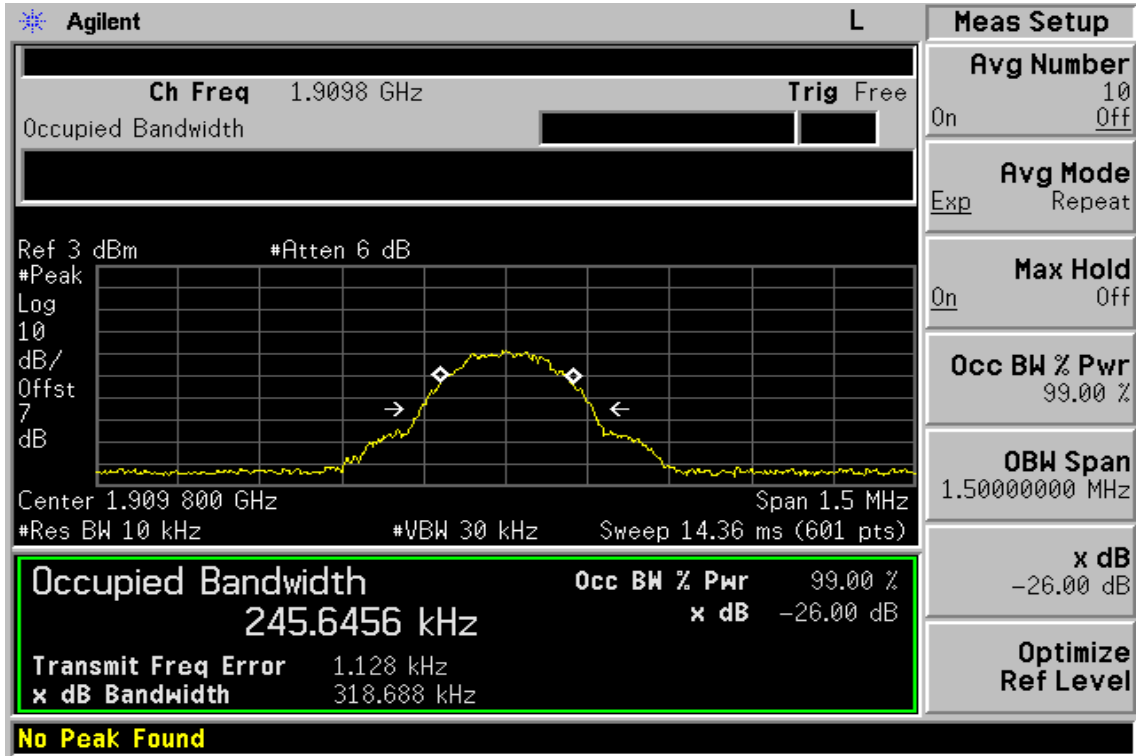

Unless otherwise stated the results shown in this test report refer only to the sample(s) tested. This test report cannot be reproduced, except in full, without prior written permission of the Company. 除非另有說明，此報告結果僅對測試之樣品負責。本報告未經本公司書面許可，不可部份複製。

This Test Report is issued by the Company under its General Conditions of Service which is available on request or accessible at [http://www.sgs.com/terms\\_and\\_conditions.htm](http://www.sgs.com/terms_and_conditions.htm). Attention is drawn to the limitation of liability, indemnification and jurisdiction issues defined therein. Any holder of this Test Report is advised that information contained hereon reflects the Company's findings at the time of its intervention only and within the limits of Client's instructions, if any. The Company's sole responsibility is to its Client and this document does not exonerate parties to a transaction from exercising all their rights and obligations under the transaction documents. Any unauthorized alteration, forgery or falsification of the content or appearance of this document is unlawful and offenders may be prosecuted to the fullest extent of the law.



## 8.8 OUT OF BAND EMISSION AT ANTENNA TERMINALS

### 8.1 Standard Applicable

According to FCC §2.1051.

FCC §22.917(a),§24.238(a), the magnitude of each spurious and harmonic emission that can be detected when the equipment is operated under the conditions specified in the instruction manual and/ or alignment procedure, shall not be less than  $43 + 10 \log$  (mean output power in watts) dBc below the mean power output outside a license's frequency block (-13dBm)

### 8.2 Test SET-UP

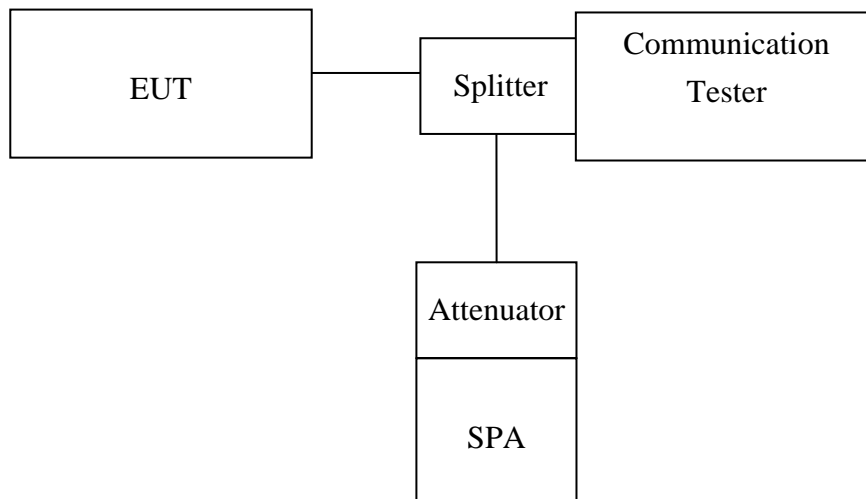

*Note: Measurement setup for testing on Antenna connector*

### 8.3 Measurement Procedure

The RF output of the transceiver was connected to a spectrum analyzer through appropriate attenuation. The resolution bandwidth of the spectrum analyzer was set at 1MHz, sufficient scans were taken to show the out of band Emissions if any up to 10th harmonic.

For the out of band: Set the RBW, VBW = 1MHz, Start=30MHz, Stop= 10 th harmonic.  
 Limit = -13dBm

Band Edge Requirements: In the 1 MHz bands immediately outside and adjacent to the frequency block, a resolution bandwidth of at least 1 percent of the emission bandwidth of the fundamental emission of the transmitter may be employed to measure the out of band Emissions. Limit, -13dBm.

Unless otherwise stated the results shown in this test report refer only to the sample(s) tested. This test report cannot be reproduced, except in full, without prior written permission of the Company. 除非另有說明，此報告結果僅對測試之樣品負責。本報告未經本公司書面許可，不可部份複製。

This Test Report is issued by the Company under its General Conditions of Service which is available on request or accessible at [http://www.sgs.com/terms\\_and\\_conditions.htm](http://www.sgs.com/terms_and_conditions.htm). Attention is drawn to the limitation of liability, indemnification and jurisdiction issues defined therein. Any holder of this Test Report is advised that information contained hereon reflects the Company's findings at the time of its intervention only and within the limits of Client's instructions, if any. The Company's sole responsibility is to its Client and this document does not exonerate parties to a transaction from exercising all their rights and obligations under the transaction documents. Any unauthorized alteration, forgery or falsification of the content or appearance of this document is unlawful and offenders may be prosecuted to the fullest extent of the law.

**8.4 Measurement Equipment Used:**

Conducted Emission Test Site					
EQUIPMENT TYPE	MFR	MODEL NUMBER	SERIAL NUMBER	LAST CAL.	CAL DUE.
Spectrum Analyzer	Agilent	E4446A	MY43360126	04/27/2008	04/26/2009
Spectrum Analyzer	Agilent	7405A	US41160416	06/28/2008	06/29/2009
Power Sensor	Anritsu	MA2490A	31431	06/28/2008	06/29/2009
Power Meter	Anritsu	ML2487A	6K00002070	06/28/2008	06/29/2009
Temperature Chamber	TERCHY	MHG-120LF	911009	11/11/2007	11/12/2008
Low Loss Cable	HUBER+SUHNER	SUCOFLEX 104PEA	N/A	N/A	N/A
Attenuator	Mini-Circuit	BW-S10W5	N/A	10/07/2007	10/06/2008
Attenuator	Mini-Circuit	BW-S6W5	N/A	10/07/2007	10/06/2008
Splitter	Agilent	11636B	51728	09/23/2007	9/22/2008
Signal Generator	R&S	SMR40	100210	11/09/2007	11/10/2008
DC Power Supply	Agilent	6038A	2929A-07548	01/06/2008	01/05/2009

Unless otherwise stated the results shown in this test report refer only to the sample(s) tested. This test report cannot be reproduced, except in full, without prior written permission of the Company. 除非另有說明，此報告結果僅對測試之樣品負責。本報告未經本公司書面許可，不可部份複製。  
 This Test Report is issued by the Company under its General Conditions of Service which is available on request or accessible at [http://www.sgs.com/terms\\_and\\_conditions.htm](http://www.sgs.com/terms_and_conditions.htm). Attention is drawn to the limitation of liability, indemnification and jurisdiction issues defined therein. Any holder of this Test Report is advised that information contained hereon reflects the Company's findings at the time of its intervention only and within the limits of Client's instructions, if any. The Company's sole responsibility is to its Client and this document does not exonerate parties to a transaction from exercising all their rights and obligations under the transaction documents. Any unauthorized alteration, forgery or falsification of the content or appearance of this document is unlawful and offenders may be prosecuted to the fullest extent of the law.

### 8.5 Measurement Result

Figure 8-1: Out of Band emission at antenna terminals– GSM Channel Lowest

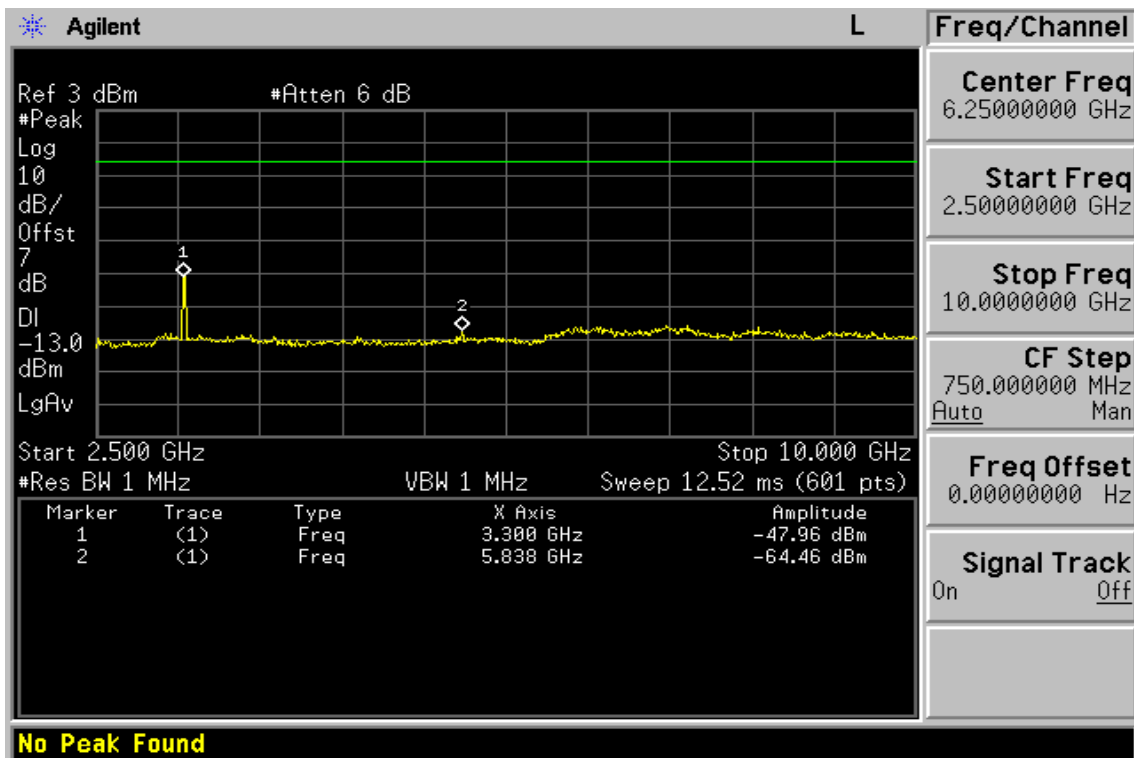
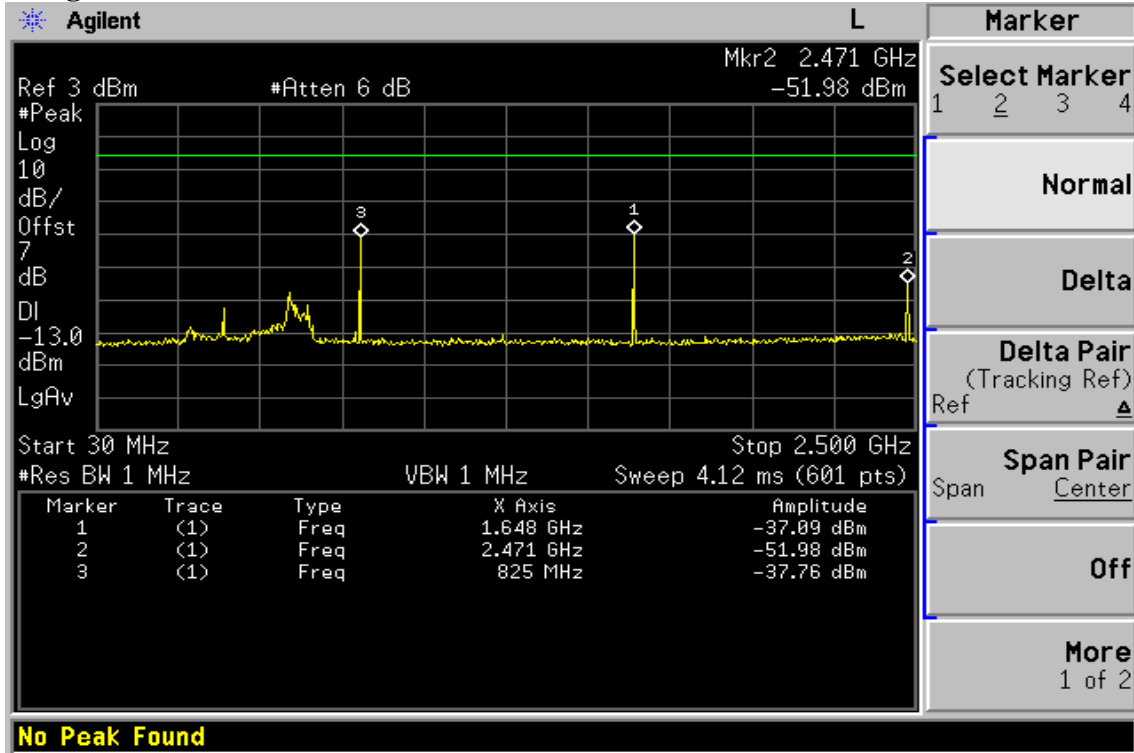

Unless otherwise stated the results shown in this test report refer only to the sample(s) tested. This test report cannot be reproduced, except in full, without prior written permission of the Company. 除非另有說明，此報告結果僅對測試之樣品負責。本報告未經本公司書面許可，不可部份複製。  
 This Test Report is issued by the Company under its General Conditions of Service which is available on request or accessible at [http://www.sgs.com/terms\\_and\\_conditions.htm](http://www.sgs.com/terms_and_conditions.htm). Attention is drawn to the limitation of liability, indemnification and jurisdiction issues defined therein. Any holder of this Test Report is advised that information contained hereon reflects the Company's findings at the time of its intervention only and within the limits of Client's instructions, if any. The Company's sole responsibility is to its Client and this document does not exonerate parties to a transaction from exercising all their rights and obligations under the transaction documents. Any unauthorized alteration, forgery or falsification of the content or appearance of this document is unlawful and offenders may be prosecuted to the fullest extent of the law.

Figure 8-2: Out of Band emission at antenna terminals –GSM Channel Mid

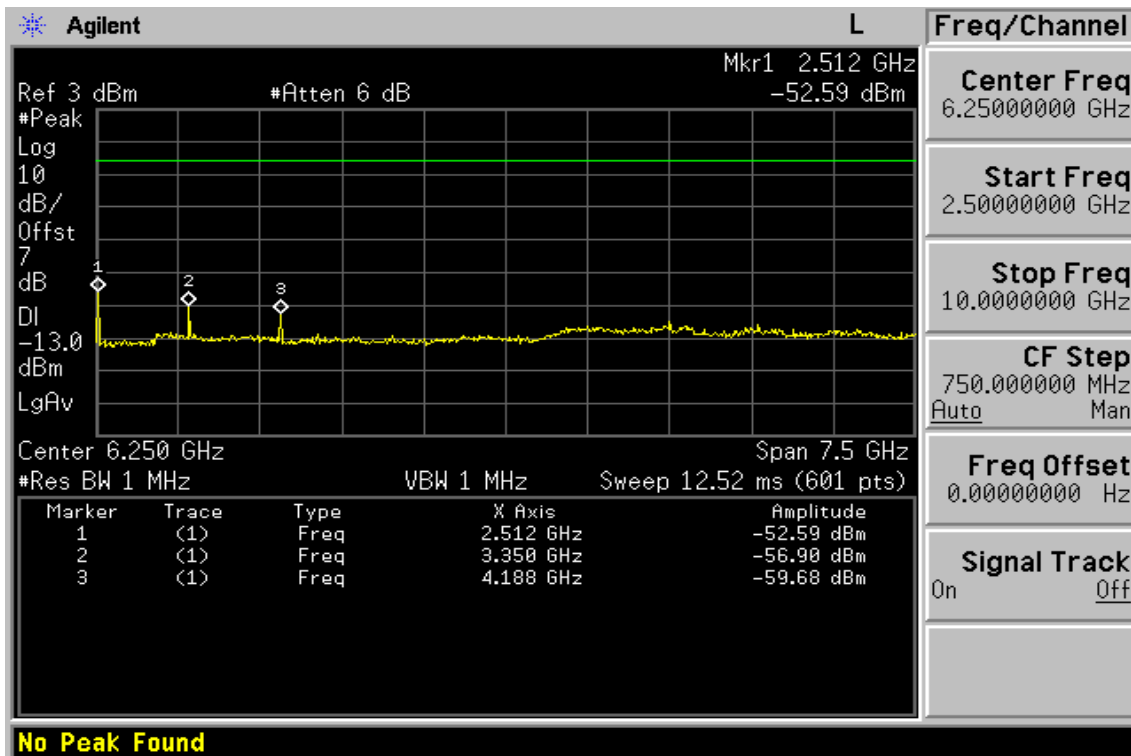
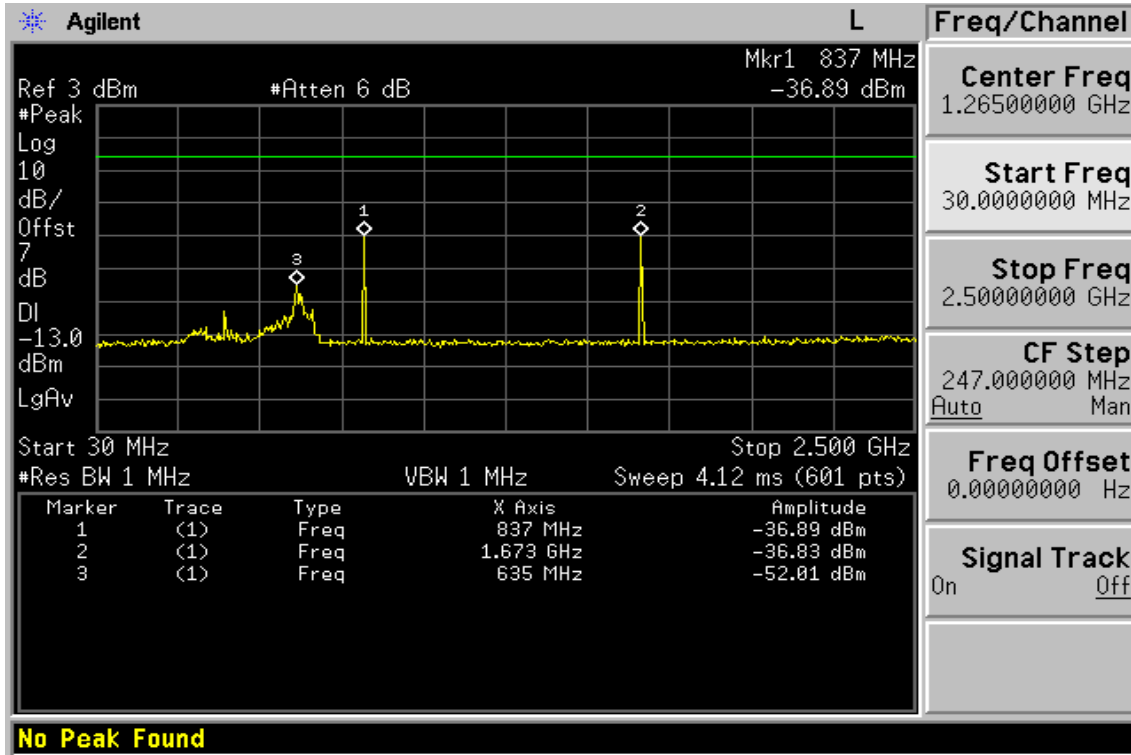

Unless otherwise stated the results shown in this test report refer only to the sample(s) tested. This test report cannot be reproduced, except in full, without prior written permission of the Company. 除非另有說明，此報告結果僅對測試之樣品負責。本報告未經本公司書面許可，不可部份複製。  
 This Test Report is issued by the Company under its General Conditions of Service which is available on request or accessible at [http://www.sgs.com/terms\\_and\\_conditions.htm](http://www.sgs.com/terms_and_conditions.htm). Attention is drawn to the limitation of liability, indemnification and jurisdiction issues defined therein. Any holder of this Test Report is advised that information contained hereon reflects the Company's findings at the time of its intervention only and within the limits of Client's instructions, if any. The Company's sole responsibility is to its Client and this document does not exonerate parties to a transaction from exercising all their rights and obligations under the transaction documents. Any unauthorized alteration, forgery or falsification of the content or appearance of this document is unlawful and offenders may be prosecuted to the fullest extent of the law.

**Figure 8-3: Out of Band emission at antenna terminals–GSM Channel Highest**

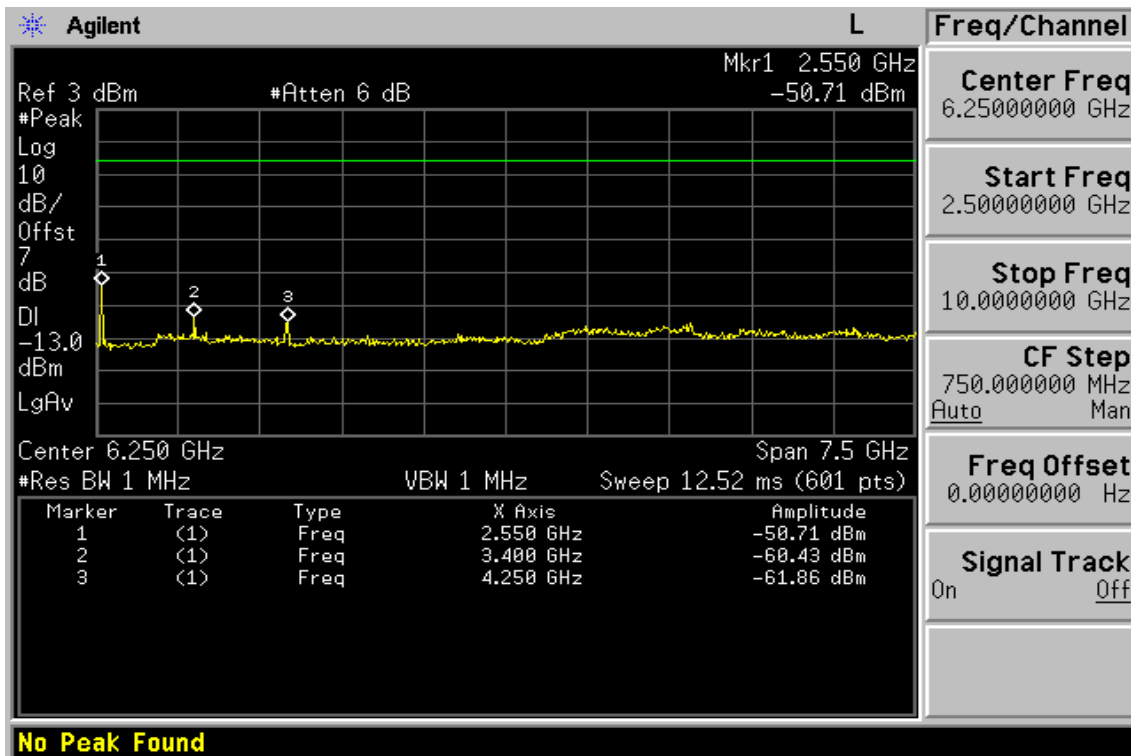
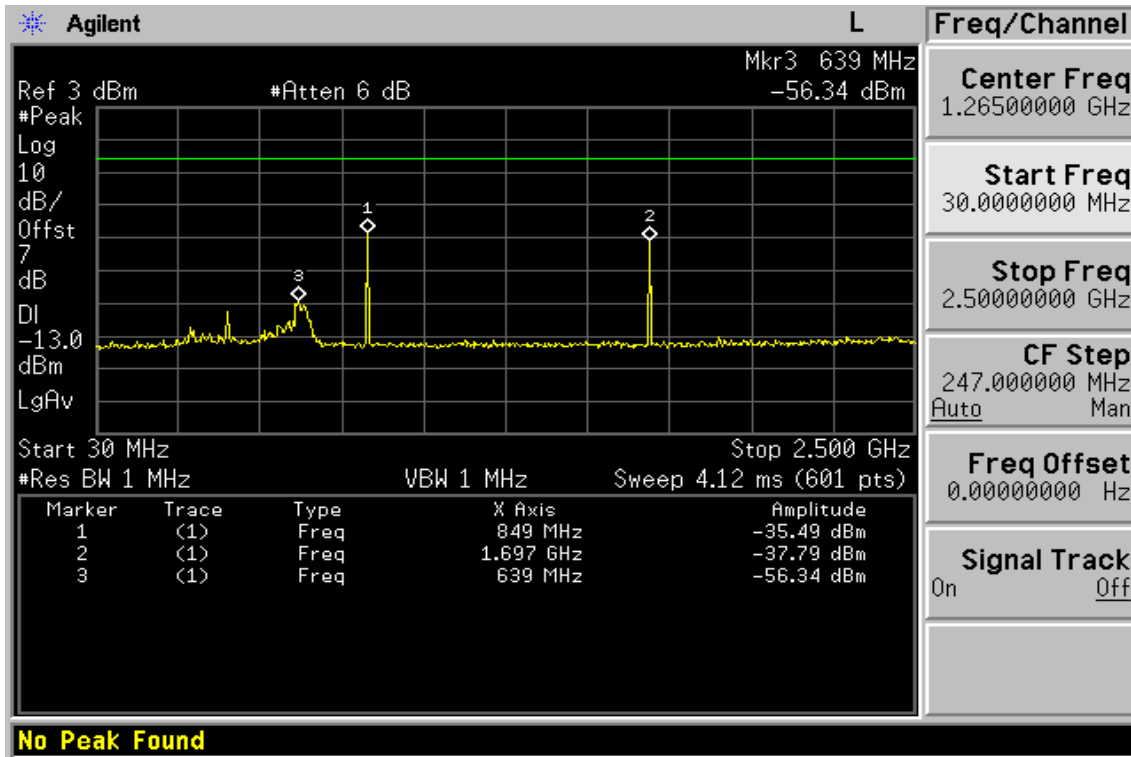

Unless otherwise stated the results shown in this test report refer only to the sample(s) tested. This test report cannot be reproduced, except in full, without prior written permission of the Company. 除非另有說明，此報告結果僅對測試之樣品負責。本報告未經本公司書面許可，不可部份複製。

This Test Report is issued by the Company under its General Conditions of Service which is available on request or accessible at [http://www.sgs.com/terms\\_and\\_conditions.htm](http://www.sgs.com/terms_and_conditions.htm). Attention is drawn to the limitation of liability, indemnification and jurisdiction issues defined therein. Any holder of this Test Report is advised that information contained hereon reflects the Company's findings at the time of its intervention only and within the limits of Client's instructions, if any. The Company's sole responsibility is to its Client and this document does not exonerate parties to a transaction from exercising all their rights and obligations under the transaction documents. Any unauthorized alteration, forgery or falsification of the content or appearance of this document is unlawful and offenders may be prosecuted to the fullest extent of the law.

Figure 8-4: Band edge emission at antenna terminals – GSM Channel Lowest

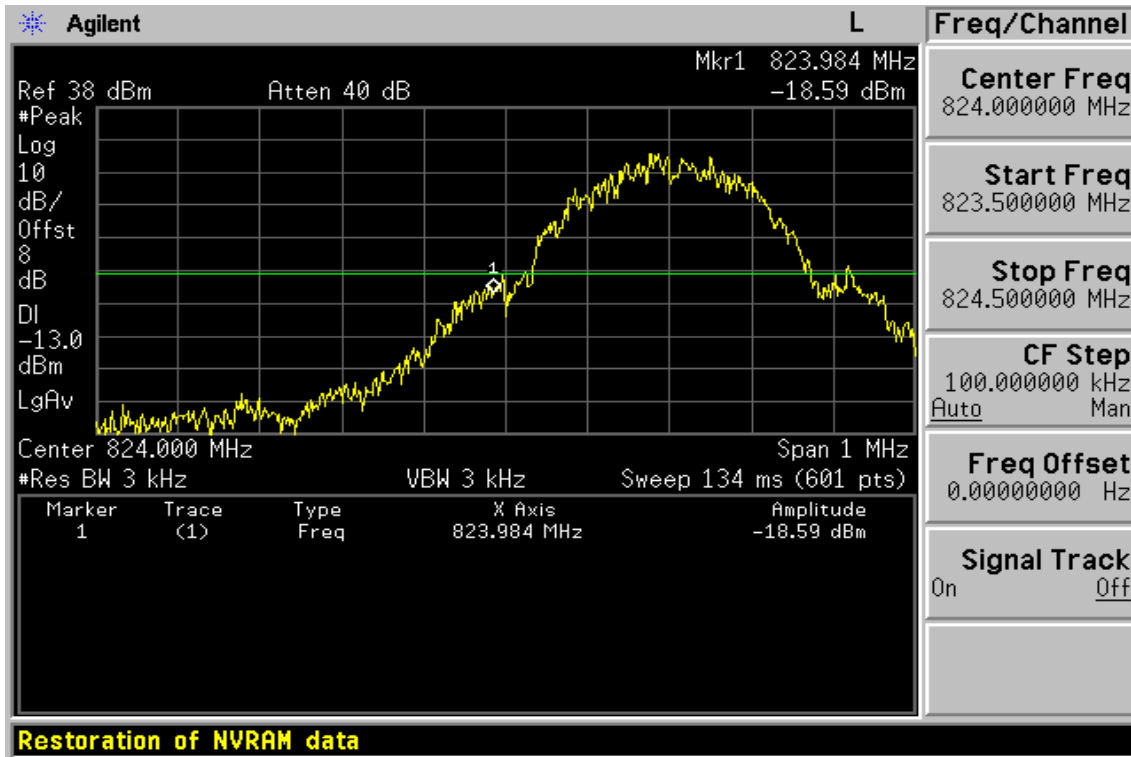
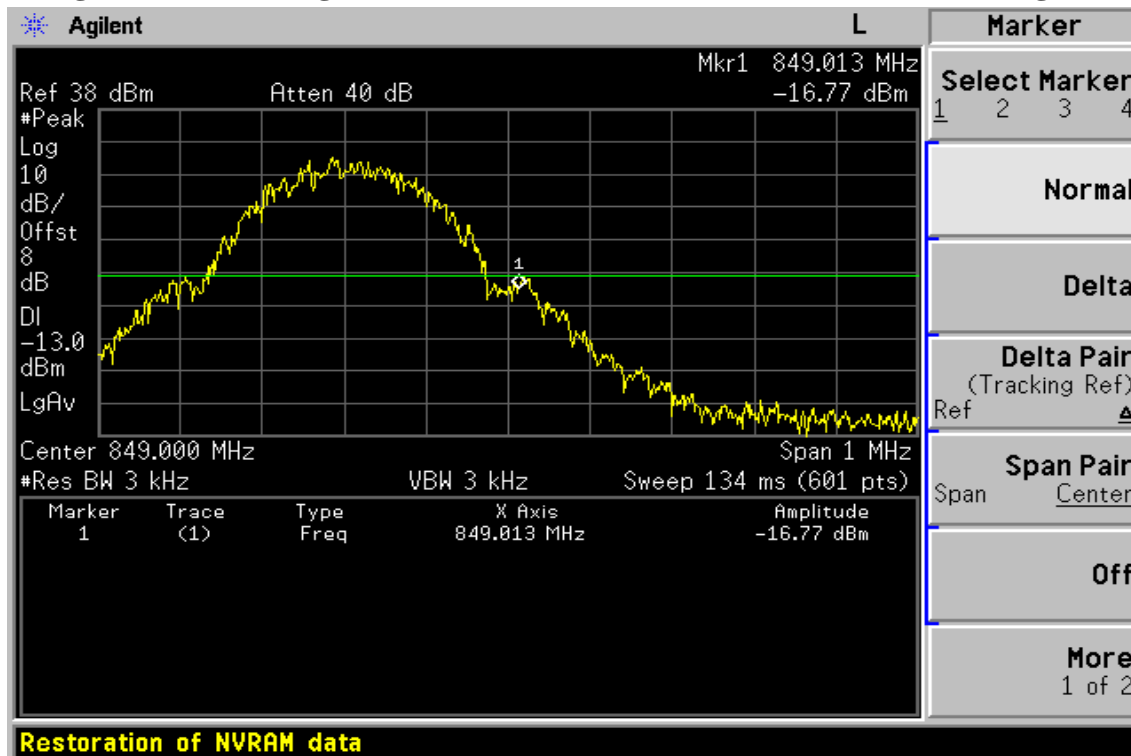

Figure 8-5: Band edge emission at antenna terminals – GSM Channel Highest



Unless otherwise stated the results shown in this test report refer only to the sample(s) tested. This test report cannot be reproduced, except in full, without prior written permission of the Company. 除非另有說明，此報告結果僅對測試之樣品負責。本報告未經本公司書面許可，不可部份複製。

This Test Report is issued by the Company under its General Conditions of Service which is available on request or accessible at [http://www.sgs.com/terms\\_and\\_conditions.htm](http://www.sgs.com/terms_and_conditions.htm). Attention is drawn to the limitation of liability, indemnification and jurisdiction issues defined therein. Any holder of this Test Report is advised that information contained hereon reflects the Company's findings at the time of its intervention only and within the limits of Client's instructions, if any. The Company's sole responsibility is to its Client and this document does not exonerate parties to a transaction from exercising all their rights and obligations under the transaction documents. Any unauthorized alteration, forgery or falsification of the content or appearance of this document is unlawful and offenders may be prosecuted to the fullest extent of the law.

**Figure 8-6: Out of Band emission at antenna terminals– PCS Channel Lowest**

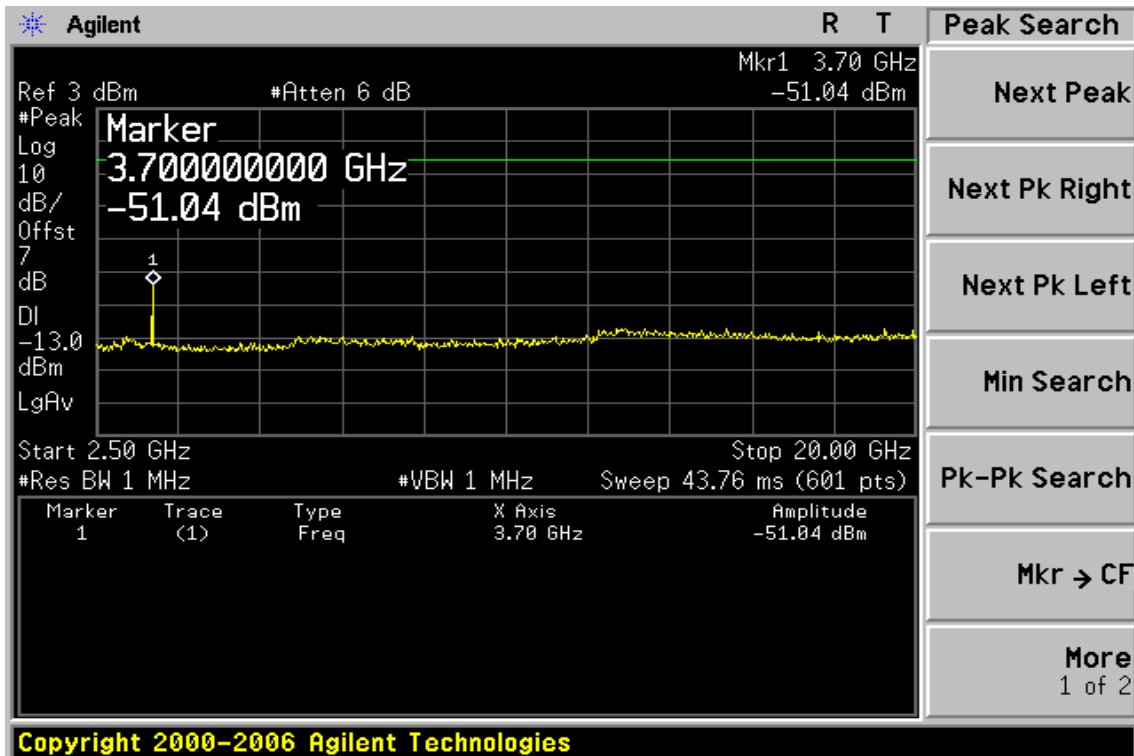
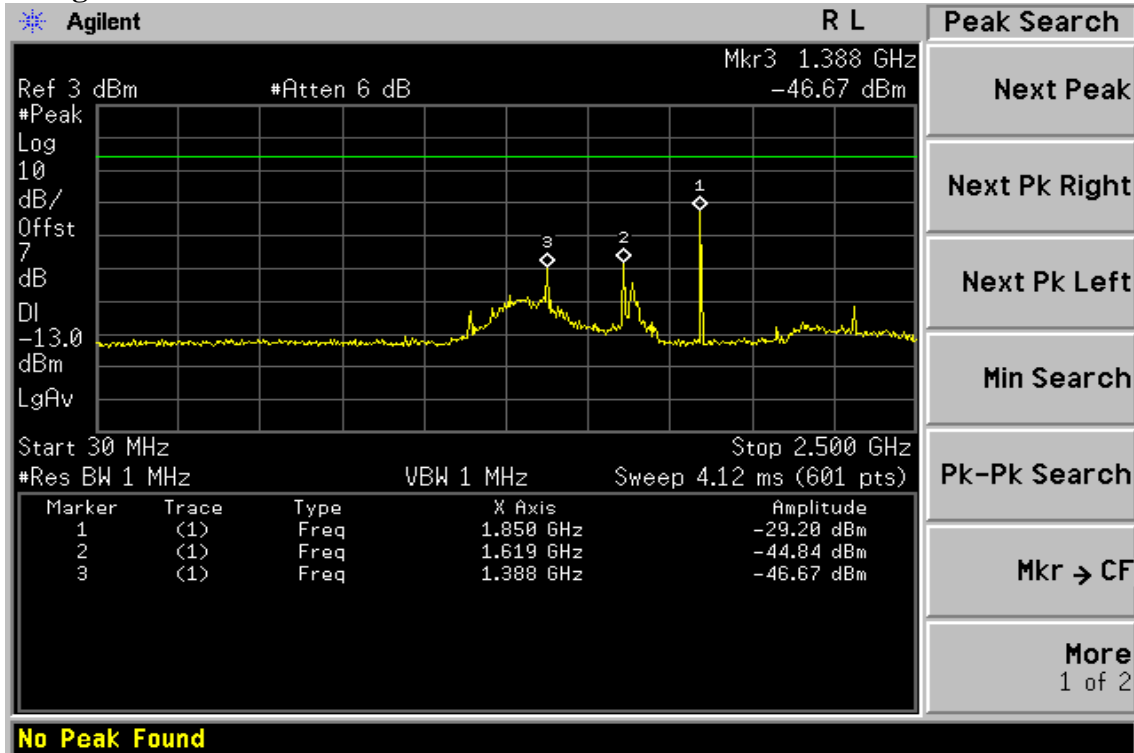

Unless otherwise stated the results shown in this test report refer only to the sample(s) tested. This test report cannot be reproduced, except in full, without prior written permission of the Company. 除非另有說明，此報告結果僅對測試之樣品負責。本報告未經本公司書面許可，不可部份複製。

This Test Report is issued by the Company under its General Conditions of Service which is available on request or accessible at [http://www.sgs.com/terms\\_and\\_conditions.htm](http://www.sgs.com/terms_and_conditions.htm). Attention is drawn to the limitation of liability, indemnification and jurisdiction issues defined therein. Any holder of this Test Report is advised that information contained hereon reflects the Company's findings at the time of its intervention only and within the limits of Client's instructions, if any. The Company's sole responsibility is to its Client and this document does not exonerate parties to a transaction from exercising all their rights and obligations under the transaction documents. Any unauthorized alteration, forgery or falsification of the content or appearance of this document is unlawful and offenders may be prosecuted to the fullest extent of the law.

Figure 8-7: Out of Band emission at antenna terminals –PCS Channel Mid

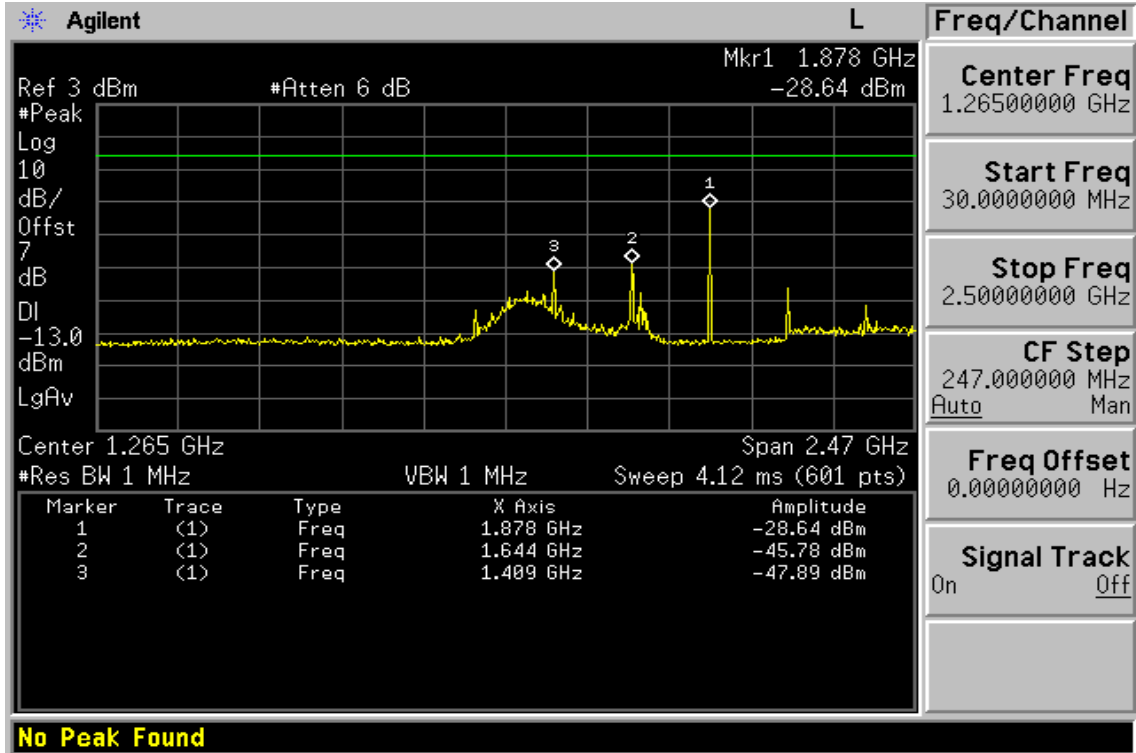

No Peak Found

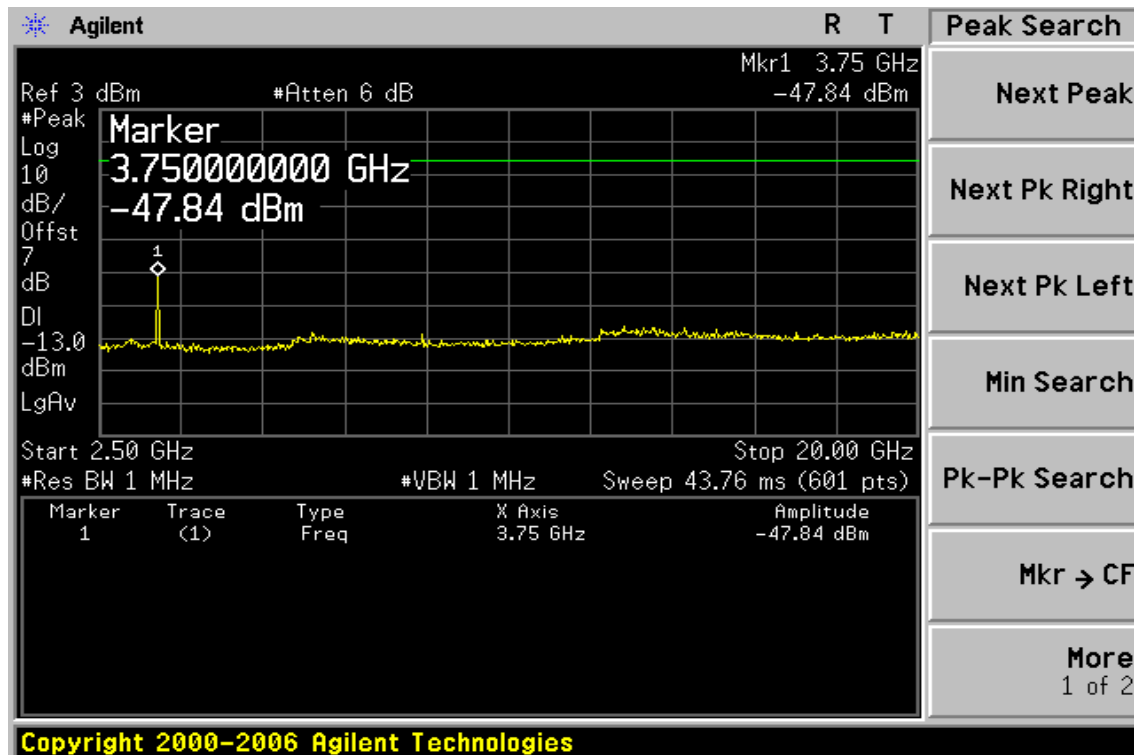

Copyright 2000–2006 Agilent Technologies

Unless otherwise stated the results shown in this test report refer only to the sample(s) tested. This test report cannot be reproduced, except in full, without prior written permission of the Company. 除非另有說明，此報告結果僅對測試之樣品負責。本報告未經本公司書面許可，不可部份複製。

This Test Report is issued by the Company under its General Conditions of Service which is available on request or accessible at [http://www.sgs.com/terms\\_and\\_conditions.htm](http://www.sgs.com/terms_and_conditions.htm). Attention is drawn to the limitation of liability, indemnification and jurisdiction issues defined therein. Any holder of this Test Report is advised that information contained hereon reflects the Company's findings at the time of its intervention only and within the limits of Client's instructions, if any. The Company's sole responsibility is to its Client and this document does not exonerate parties to a transaction from exercising all their rights and obligations under the transaction documents. Any unauthorized alteration, forgery or falsification of the content or appearance of this document is unlawful and offenders may be prosecuted to the fullest extent of the law.



Figure 8-8: Out of Band emission at antenna terminals–PCS Channel Highest

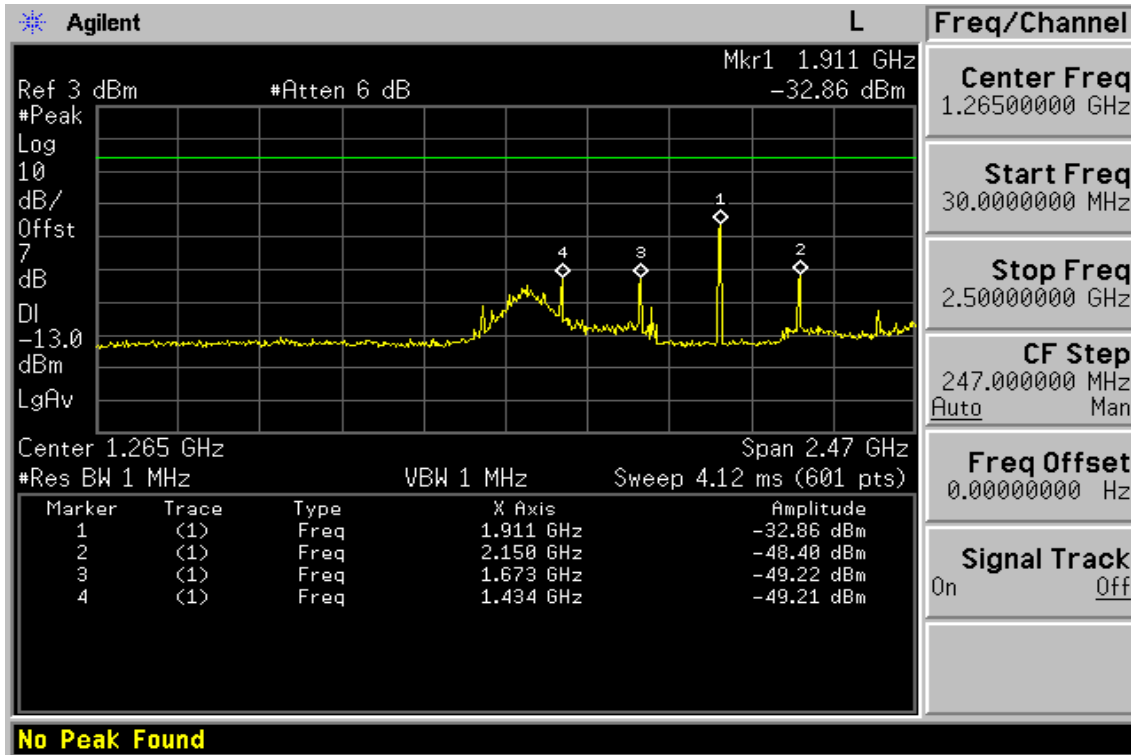

No Peak Found

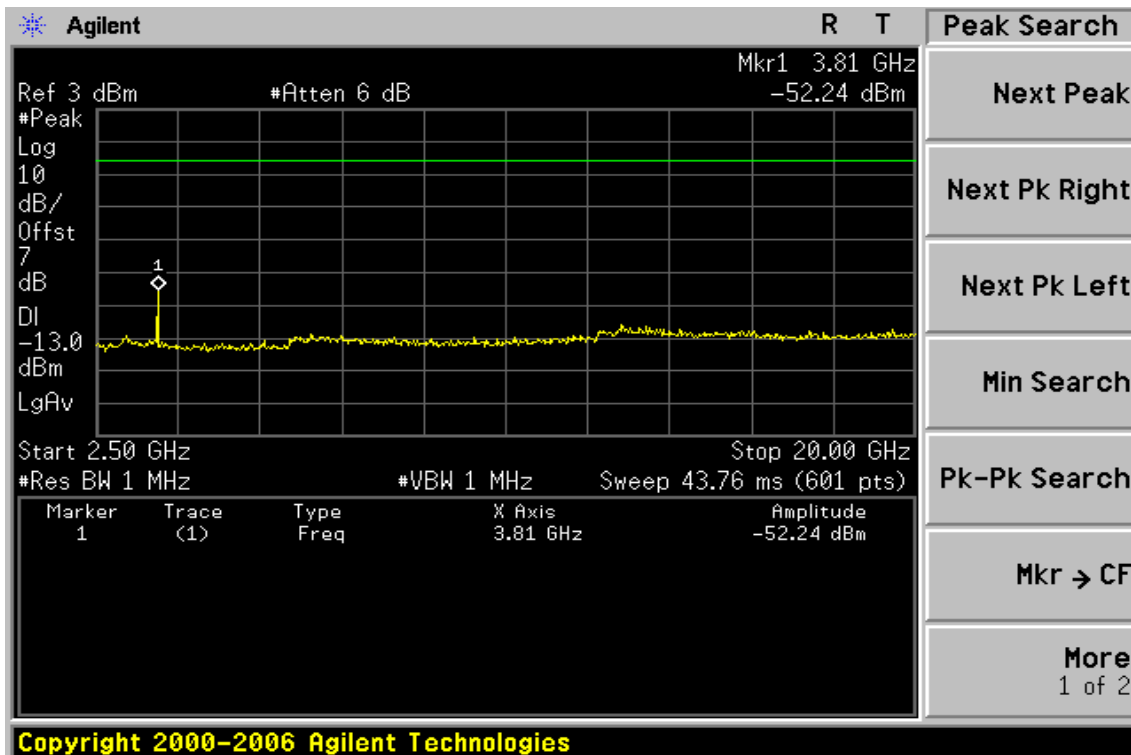

Copyright 2000–2006 Agilent Technologies

Unless otherwise stated the results shown in this test report refer only to the sample(s) tested. This test report cannot be reproduced, except in full, without prior written permission of the Company. 除非另有說明，此報告結果僅對測試之樣品負責。本報告未經本公司書面許可，不可部份複製。

This Test Report is issued by the Company under its General Conditions of Service which is available on request or accessible at [http://www.sgs.com/terms\\_and\\_conditions.htm](http://www.sgs.com/terms_and_conditions.htm). Attention is drawn to the limitation of liability, indemnification and jurisdiction issues defined therein. Any holder of this Test Report is advised that information contained hereon reflects the Company's findings at the time of its intervention only and within the limits of Client's instructions, if any. The Company's sole responsibility is to its Client and this document does not exonerate parties to a transaction from exercising all their rights and obligations under the transaction documents. Any unauthorized alteration, forgery or falsification of the content or appearance of this document is unlawful and offenders may be prosecuted to the fullest extent of the law.

**Figure 8-9: Band edge emission at antenna terminals – PCS Channel Lowest**

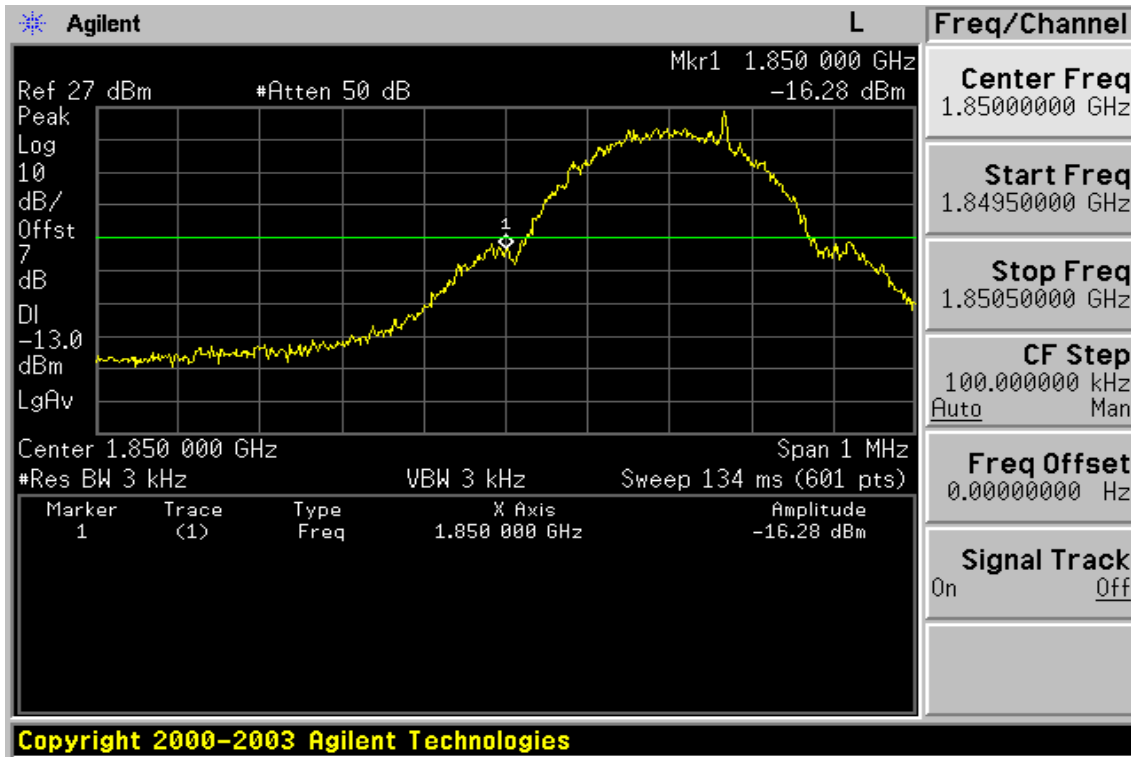

**Figure 8-10: Band edge emission at antenna terminals – PCS Channel Highest**

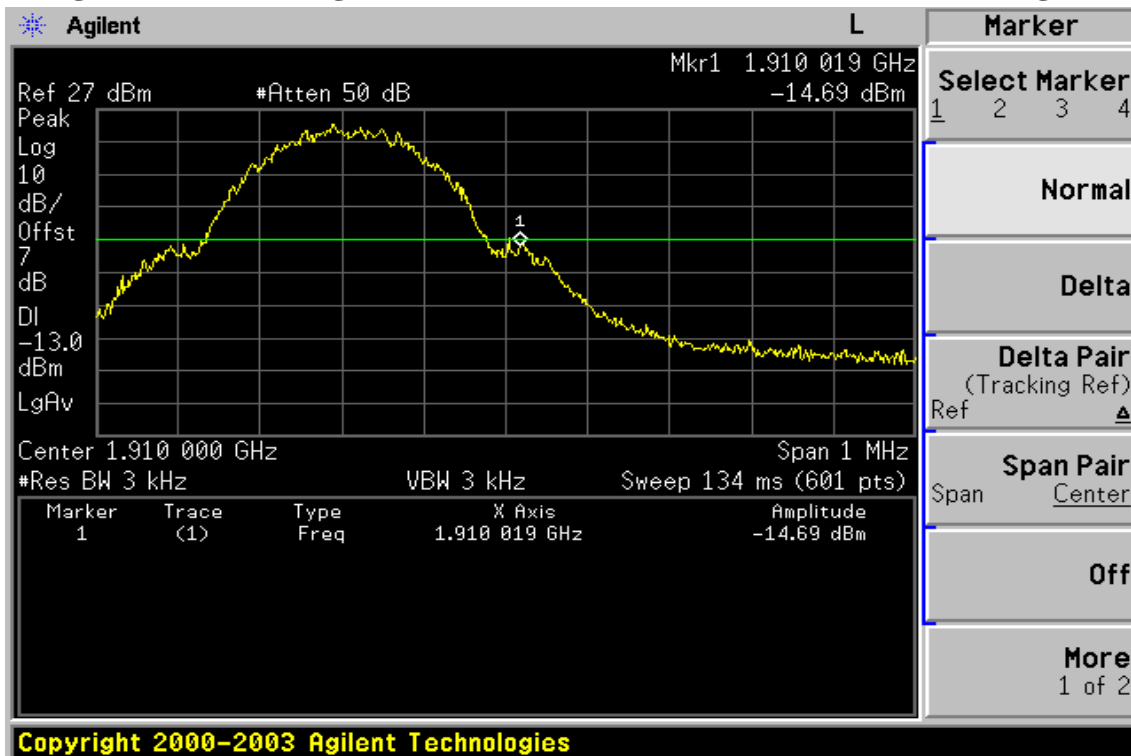

Unless otherwise stated the results shown in this test report refer only to the sample(s) tested. This test report cannot be reproduced, except in full, without prior written permission of the Company. 除非另有說明，此報告結果僅對測試之樣品負責。本報告未經本公司書面許可，不可部份複製。  
 This Test Report is issued by the Company under its General Conditions of Service which is available on request or accessible at [http://www.sgs.com/terms\\_and\\_conditions.htm](http://www.sgs.com/terms_and_conditions.htm). Attention is drawn to the limitation of liability, indemnification and jurisdiction issues defined therein. Any holder of this Test Report is advised that information contained hereon reflects the Company's findings at the time of its intervention only and within the limits of Client's instructions, if any. The Company's sole responsibility is to its Client and this document does not exonerate parties to a transaction from exercising all their rights and obligations under the transaction documents. Any unauthorized alteration, forgery or falsification of the content or appearance of this document is unlawful and offenders may be prosecuted to the fullest extent of the law.

## 9.9 FIELD STRENGTH OF SPURIOUS RADIATION MEASUREMENT

### 9.1 Standard Applicable

According to FCC §2.1053,

FCC §22.917(a),§24.238(a), the magnitude of each spurious and harmonic emission that can be detected when the equipment is operated under the conditions specified in the instruction manual and/ or alignment procedure, shall not be less than  $43 + 10 \log$  (mean output power in watts) dBc below the mean power output outside a license's frequency block (-13dBm)

### 9.2 EUT Setup (Block Diagram of Configuration)

(A) Radiated Emission Test Set-Up, Frequency Below 1000MHz

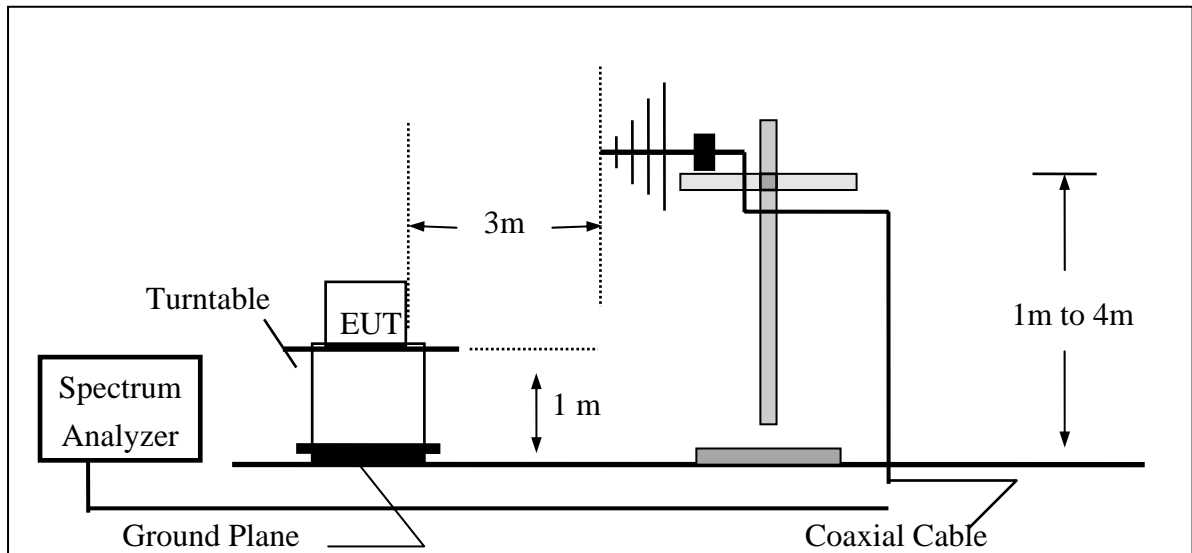

Unless otherwise stated the results shown in this test report refer only to the sample(s) tested. This test report cannot be reproduced, except in full, without prior written permission of the Company. 除非另有說明，此報告結果僅對測試之樣品負責。本報告未經本公司書面許可，不可部份複製。

This Test Report is issued by the Company under its General Conditions of Service which is available on request or accessible at [http://www.sgs.com/terms\\_and\\_conditions.htm](http://www.sgs.com/terms_and_conditions.htm). Attention is drawn to the limitation of liability, indemnification and jurisdiction issues defined therein. Any holder of this Test Report is advised that information contained hereon reflects the Company's findings at the time of its intervention only and within the limits of Client's instructions, if any. The Company's sole responsibility is to its Client and this document does not exonerate parties to a transaction from exercising all their rights and obligations under the transaction documents. Any unauthorized alteration, forgery or falsification of the content or appearance of this document is unlawful and offenders may be prosecuted to the fullest extent of the law.

(B) Radiated Emission Test Set-UP Frequency Over 1 GHz

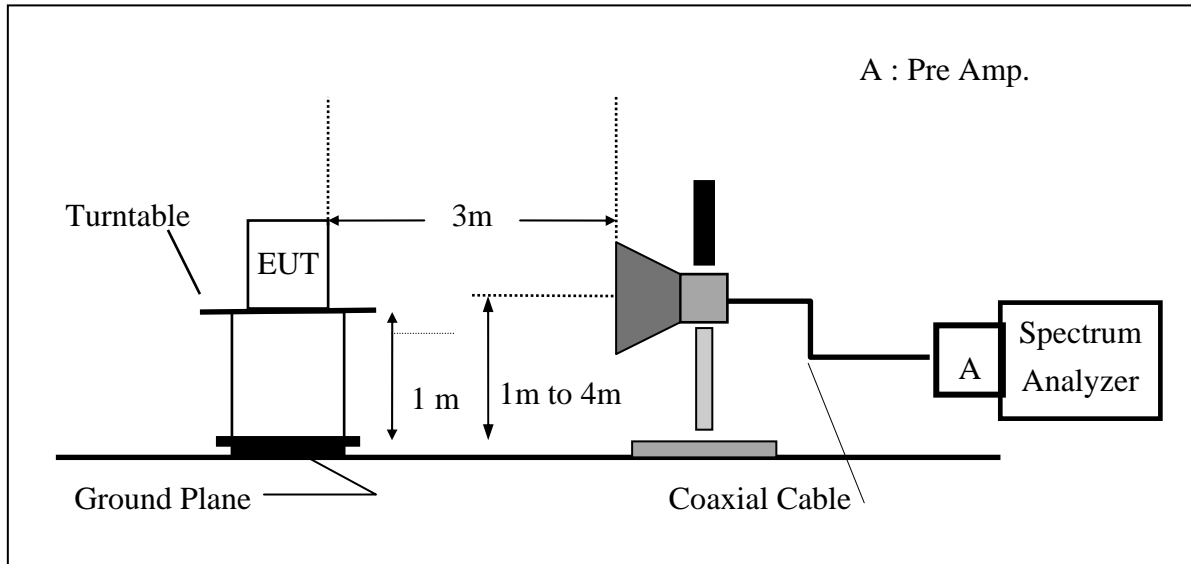

(C) Substituted Method Test Set-UP

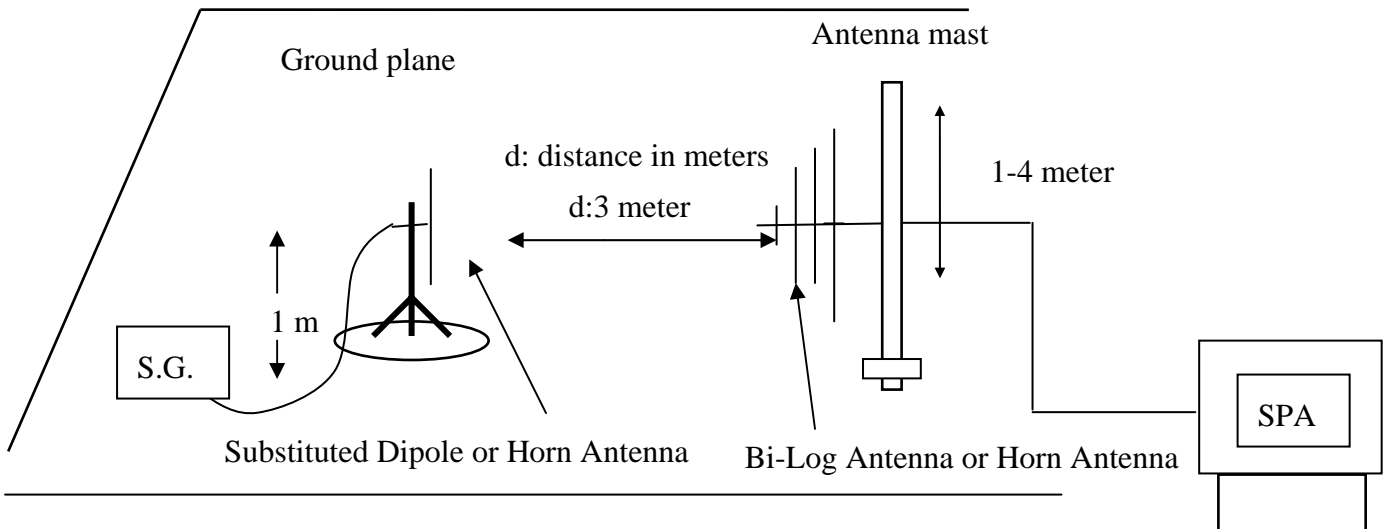

Unless otherwise stated the results shown in this test report refer only to the sample(s) tested. This test report cannot be reproduced, except in full, without prior written permission of the Company. 除非另有說明，此報告結果僅對測試之樣品負責。本報告未經本公司書面許可，不可部份複製。

This Test Report is issued by the Company under its General Conditions of Service which is available on request or accessible at [http://www.sgs.com/terms\\_and\\_conditions.htm](http://www.sgs.com/terms_and_conditions.htm). Attention is drawn to the limitation of liability, indemnification and jurisdiction issues defined therein. Any holder of this Test Report is advised that information contained hereon reflects the Company's findings at the time of its intervention only and within the limits of Client's instructions, if any. The Company's sole responsibility is to its Client and this document does not exonerate parties to a transaction from exercising all their rights and obligations under the transaction documents. Any unauthorized alteration, forgery or falsification of the content or appearance of this document is unlawful and offenders may be prosecuted to the fullest extent of the law.

### 9.3 Measurement Procedure

The EUT was placed on a non-conductive, The measurement antenna was placed at a distance of 3 meters from the EUT. During the tests, the antenna height and the EUT azimuth were varied in order to identify the maximum level of emissions from the EUT. This maximization process was repeated with the EUT positioned in each of its three orthogonal orientations.

During the measurement, the EUT was communication with the station. The highest emission was recorded with the rotation of the turntable and the lowering of the test antenna from 4m to 1m. The reading was recorded and the field strength (E in dBuV/m) was calculated. And Peak detector was used during this test.

When measurement procedures for electric field radiated emissions above 1 GHz the EUT measurement is to be made “while keeping the antenna in the ‘cone of radiation’ from that area and pointed at the area both in azimuth and elevation, with polarization oriented for maximum response.” is still within the 3dB illumination BW of the measurement antenna.

ERP was measured using a substitution method. The EUT was replaced by dipole antenna connected, the S.G. output was recorded and ERP was calculated as follows:

EIRP was measured using a substitution method. The EUT was replaced by or horn antenna connected, the S.G. output was recorded and EIRP was calculated as follows:

$$\text{ERP} = \text{S.G. output (dBm)} + \text{Antenna Gain (dBd)} - \text{Cable Loss (dB)}$$

$$\text{EIRP} = \text{S.G. output (dBm)} + \text{Antenna Gain (dBi)} - \text{Cable Loss (dB)}$$

Unless otherwise stated the results shown in this test report refer only to the sample(s) tested. This test report cannot be reproduced, except in full, without prior written permission of the Company. 除非另有說明，此報告結果僅對測試之樣品負責。本報告未經本公司書面許可，不可部份複製。

This Test Report is issued by the Company under its General Conditions of Service which is available on request or accessible at [http://www.sgs.com/terms\\_and\\_conditions.htm](http://www.sgs.com/terms_and_conditions.htm). Attention is drawn to the limitation of liability, indemnification and jurisdiction issues defined therein. Any holder of this Test Report is advised that information contained hereon reflects the Company's findings at the time of its intervention only and within the limits of Client's instructions, if any. The Company's sole responsibility is to its Client and this document does not exonerate parties to a transaction from exercising all their rights and obligations under the transaction documents. Any unauthorized alteration, forgery or falsification of the content or appearance of this document is unlawful and offenders may be prosecuted to the fullest extent of the law.

**6.49.4 Measurement Equipment Used:**

EQUIPMENT TYPE	MFR	MODEL NUMBER	SERIAL NUMBER	LAST CAL.	CAL DUE.
Spectrum Analyzer	Agilent	E4446A	MY43360126	04/27/2008	04/26/2009
Spectrum Analyzer	Agilent	7405A	US41160416	06/28/2008	06/29/2009
Spectrum Analyzer	R&S	FSP 40	100034	11/09/2007	11/10/2008
Communication Test	R&S	CMU200	N/A	N/A	N/A
Bi-log Antenna	SCHWAZBECK	VULB9160	3224	11/14/2007	13/11/2008
Horn antenna	SCHWAZBECK	BBHA 9120D	309/320	08/16/2008	08/15/2009
Pre-Amplifier	HP	8447D	2944A09469	07/19/2008	07/18/2009
Pre-Amplifier	HP	8494B	3008A00578	02/26/2008	02/25/2009
Signal Generator	R&S	SMR40	100210	02/09/2008	02/10/2009
Turn Table	HD	DT420	N/A	N.C.R	N.C.R
Antenna Tower	HD	MA240-N	240/657	N.C.R	N.C.R
Controller	HD	HD100	N/A	N.C.R	N.C.R
Low Loss Cable	HUBER+SUHNER	SUCOFLEX 104PEA-10M	10m	10/09/2007	10/08/2008
Low Loss Cable	HUBER+SUHNER	SUCOFLEX 104PEA-3M	3m	10/09/2007	10/08/2008
Low Loss Cable	HUBER+SUHNER	SUCOFLEX 104PEA-0.5M	0.5m	10/09/2007	10/08/2008
Site NSA	SGS	966 chamber	N/A	11/17/2007	11/16/2008
Attenuator	Mini-Circuit	BW-S10W5	N/A	09/23/2007	09/22/2008
Dipole Antenna	SCHWAZBECK	VHAP	908/909	06/10/2008	06/11/2009
Dipole Antenna	SCHWAZBECK	UHAP	891/892	06/10/2008	06/11/2009
Horn antenna	SCHWAZBECK	BBHA 9120D	N/A	08/16/2007	08/15/2008

**9.5 Measurement Result**

Refer to attach tabular data sheets.

Unless otherwise stated the results shown in this test report refer only to the sample(s) tested. This test report cannot be reproduced, except in full, without prior written permission of the Company. 除非另有說明，此報告結果僅對測試之樣品負責。本報告未經本公司書面許可，不可部份複製。  
 This Test Report is issued by the Company under its General Conditions of Service which is available on request or accessible at [http://www.sgs.com/terms\\_and\\_conditions.htm](http://www.sgs.com/terms_and_conditions.htm). Attention is drawn to the limitation of liability, indemnification and jurisdiction issues defined therein. Any holder of this Test Report is advised that information contained hereon reflects the Company's findings at the time of its intervention only and within the limits of Client's instructions, if any. The Company's sole responsibility is to its Client and this document does not exonerate parties to a transaction from exercising all their rights and obligations under the transaction documents. Any unauthorized alteration, forgery or falsification of the content or appearance of this document is unlawful and offenders may be prosecuted to the fullest extent of the law.

**Radiated Spurious Emission Measurement Result: GSM 850 Mode**

Operation Mode	: TX CH Low E2 Mode	Test Date:	May.10,2008
Fundamental Frequency	: 824.20 MHz	Test By:	Duka
Temperature	: 25°C	Pol:	Ver
Humidity	: 65%		

Freq. (MHz)	SPA. Reading (dBuV)	Ant.Pol. H/V	S.G Out-put (dBm)	Antenna Gain (dB/dBi)	Cable Loss (dB)	ERP/EIRP (dBm)	Limit (dBm)	Safe Margin (dBm)
41.64	42.47	V	-60.18	-2.31	0.80	-63.30	-13.00	-50.30
62.98	43.54	V	-67.91	-0.64	0.96	-69.52	-13.00	-56.52
106.63	41.62	V	-61.27	-7.77	1.25	-70.29	-13.00	-57.29
162.89	33.66	V	-65.11	-7.81	1.49	-74.41	-13.00	-61.41
288.99	39.04	V	-60.79	-7.91	1.99	-70.69	-13.00	-57.69
824.00	76.48	V	-10.85	-7.87	3.64	-22.37	-13.00	-9.37
1648.40	52.05	V	-54.99	9.29	5.06	-50.76	-13.00	-37.76
2472.60	---	V		10.08	6.30		-13.00	
3296.80	---	V		12.17	7.26		-13.00	
4121.00	---	V		12.61	8.33		-13.00	
4945.20	---	V		12.65	9.19		-13.00	
5769.40	---	V		13.55	9.80		-13.00	
6593.60	---	V		12.05	10.61		-13.00	
7417.80	---	V		11.49	11.28		-13.00	
8242.00	---	V		11.48	12.26		-13.00	

Measurement uncertainty	30MHz - 80MHz: 5.04dB
	80MHz - 1000MHz: 3.76dB
	1GHz - 13GHz: 4.45dB

Remark :

- 1 The emission behaviors belong to narrowband spurious emission.
- 2 Remark"---" means that the emission level is too low to be measured
- 3 The result basic equation calculation is as follows:
- 4  $ERP/EIRP (dBm) = SG \text{ Setting}(dBm) + Antenna \text{ Gain} (dB/dBi) - Cable \text{ loss} (dB)$

Unless otherwise stated the results shown in this test report refer only to the sample(s) tested. This test report cannot be reproduced, except in full, without prior written permission of the Company. 除非另有說明，此報告結果僅對測試之樣品負責。本報告未經本公司書面許可，不可部份複製。  
 This Test Report is issued by the Company under its General Conditions of Service which is available on request or accessible at [http://www.sgs.com/terms\\_and\\_conditions.htm](http://www.sgs.com/terms_and_conditions.htm). Attention is drawn to the limitation of liability, indemnification and jurisdiction issues defined therein. Any holder of this Test Report is advised that information contained hereon reflects the Company's findings at the time of its intervention only and within the limits of Client's instructions, if any. The Company's sole responsibility is to its Client and this document does not exonerate parties to a transaction from exercising all their rights and obligations under the transaction documents. Any unauthorized alteration, forgery or falsification of the content or appearance of this document is unlawful and offenders may be prosecuted to the fullest extent of the law.

**Radiated Spurious Emission Measurement Result: GSM 850 Mode**

Operation Mode	: TX CH Low E2 Mode	Test Date:	May.10,2008
Fundamental Frequency	: 824.20 MHz	Test By:	Duka
Temperature	: 25°C	Pol:	Hor
Humidity	: 65%		

Freq. (MHz)	SPA Reading (dBuV)	Ant.Pol. H/V	S.G Output (dBm)	Antenna Gain (dB/dBi)	Cable Loss (dB)	ERP/EIRP (dBm)	Limit (dBm)	Safe Margin (dBm)
41.64	42.91	H	-60.60	-2.31	0.80	-63.71	-13.00	-50.71
104.69	40.76	H	-62.01	-7.76	1.24	-71.01	-13.00	-58.01
150.28	36.37	H	-62.23	-7.80	1.47	-71.50	-13.00	-58.50
286.08	38.33	H	-61.64	-7.91	1.99	-71.54	-13.00	-58.54
431.58	32.97	H	-62.78	-7.69	2.51	-72.97	-13.00	-59.97
824.00	82.35	H	-5.31	-7.87	3.64	-16.83	-13.00	-3.83
1648.40	54.74	H	-52.27	9.29	5.06	-48.04	-13.00	-35.04
2472.60	---	H		10.08	6.30		-13.00	
3296.80	---	H		12.17	7.26		-13.00	
4121.00	---	H		12.61	8.33		-13.00	
4945.20	---	H		12.65	9.19		-13.00	
5769.40	---	H		13.55	9.80		-13.00	
6593.60	---	H		12.05	10.61		-13.00	
7417.80	---	H		11.49	11.28		-13.00	
8242.00	---	H		11.48	12.26		-13.00	

Measurement uncertainty	30MHz - 80MHz: 5.04dB
	80MHz -1000MHz: 3.76dB
	1GHz - 13GHz: 4.45dB

Remark :

- 1 The emission behaviors belong to narrowband spurious emission.
- 2 Remark"---" means that the emission level is too low to be measured
- 3 The result basic equation calculation is as follows:
- 4  $ERP/EIRP (dBm) = SG \text{ Setting}(dBm) + Antenna \text{ Gain} (dB/dBi) - Cable \text{ loss} (dB)$

Unless otherwise stated the results shown in this test report refer only to the sample(s) tested. This test report cannot be reproduced, except in full, without prior written permission of the Company. 除非另有說明，此報告結果僅對測試之樣品負責。本報告未經本公司書面許可，不可部份複製。  
 This Test Report is issued by the Company under its General Conditions of Service which is available on request or accessible at [http://www.sgs.com/terms\\_and\\_conditions.htm](http://www.sgs.com/terms_and_conditions.htm). Attention is drawn to the limitation of liability, indemnification and jurisdiction issues defined therein. Any holder of this Test Report is advised that information contained hereon reflects the Company's findings at the time of its intervention only and within the limits of Client's instructions, if any. The Company's sole responsibility is to its Client and this document does not exonerate parties to a transaction from exercising all their rights and obligations under the transaction documents. Any unauthorized alteration, forgery or falsification of the content or appearance of this document is unlawful and offenders may be prosecuted to the fullest extent of the law.



**Radiated Spurious Emission Measurement Result: GSM 850 Mode**

Operation Mode	: TX CH Mid E2 Mode	Test Date:	May.10,2008
Fundamental Frequency	: 836.60 MHz	Test By:	Duka
Temperature	: 25°C	Pol:	Ver
Humidity	: 65%		

Freq. (MHz)	SPA Reading (dBuV)	Ant.Pol. H/V	S.G Out-put (dBm)	Antenna Gain (dB/dBi)	Cable Loss (dB)	ERP/EIRP (dBm)	Limit (dBm)	Safe Margin (dBm)
62.98	42.27	V	-69.18	-0.64	0.96	-70.79	-13.00	-57.79
104.69	41.29	V	-61.84	-7.76	1.24	-70.84	-13.00	-57.84
138.64	37.26	V	-61.73	-7.79	1.41	-70.93	-13.00	-57.93
242.43	35.91	V	-65.00	-7.88	1.92	-74.81	-13.00	-61.81
286.08	38.77	V	-61.12	-7.91	1.99	-71.02	-13.00	-58.02
1673.20	50.96	V	-56.07	9.36	5.10	-51.81	-13.00	-38.81
2509.80	---	V		10.09	6.35		-13.00	
3346.40	---	V		12.28	7.29		-13.00	
4183.00	---	V		12.62	8.40		-13.00	
5019.60	---	V		12.67	9.26		-13.00	
5856.20	---	V		13.68	9.85		-13.00	
6692.80	---	V		11.95	10.74		-13.00	
7529.40	---	V		11.45	11.35		-13.00	
8366.00	---	V		11.59	12.43		-13.00	

Measurement uncertainty	30MHz - 80MHz: 5.04dB
	80MHz - 1000MHz: 3.76dB
	1GHz - 13GHz: 4.45dB

Remark :

- 1 The emission behaviors belong to narrowband spurious emission.
- 2 Remark"---" means that the emission level is too low to be measured
- 3 The result basic equation calculation is as follows:
- 4  $ERP/EIRP (dBm) = SG \text{ Setting}(dBm) + Antenna \text{ Gain} (dB/dBi) - Cable \text{ loss} (dB)$

Unless otherwise stated the results shown in this test report refer only to the sample(s) tested. This test report cannot be reproduced, except in full, without prior written permission of the Company. 除非另有說明，此報告結果僅對測試之樣品負責。本報告未經本公司書面許可，不可部份複製。  
 This Test Report is issued by the Company under its General Conditions of Service which is available on request or accessible at [http://www.sgs.com/terms\\_and\\_conditions.htm](http://www.sgs.com/terms_and_conditions.htm). Attention is drawn to the limitation of liability, indemnification and jurisdiction issues defined therein. Any holder of this Test Report is advised that information contained hereon reflects the Company's findings at the time of its intervention only and within the limits of Client's instructions, if any. The Company's sole responsibility is to its Client and this document does not exonerate parties to a transaction from exercising all their rights and obligations under the transaction documents. Any unauthorized alteration, forgery or falsification of the content or appearance of this document is unlawful and offenders may be prosecuted to the fullest extent of the law.

**Radiated Spurious Emission Measurement Result: GSM 850 Mode**

Operation Mode : TX CH Mid E2 Mode Test Date: May.10,2008  
 Fundamental Frequency : 836.60 MHz Test By: Duka  
 Temperature : 25°C Pol: Hor  
 Humidity : 65%

Freq. (MHz)	SPA Reading (dBuV)	Ant.Pol. H/V	S.G Out-put (dBm)	Antenna Gain (dB/dBi)	Cable Loss (dB)	ERP/EIRP (dBm)	Limit (dBm)	Safe Margin (dBm)
41.64	43.24	H	-60.27	-2.31	0.80	-63.38	-13.00	-50.38
62.98	42.81	H	-68.72	-0.64	0.96	-70.33	-13.00	-57.33
111.48	40.08	H	-62.06	-7.77	1.28	-71.10	-13.00	-58.10
145.43	36.85	H	-62.15	-7.80	1.44	-71.39	-13.00	-58.39
286.08	36.87	H	-63.10	-7.91	1.99	-73.00	-13.00	-60.00
1673.20	51.51	H	-55.49	9.36	5.10	-51.22	-13.00	-38.22
2509.80	---	H		10.09	6.35		-13.00	
3346.40	---	H		12.28	7.29		-13.00	
4183.00	---	H		12.62	8.40		-13.00	
5019.60	---	H		12.67	9.26		-13.00	
5856.20	---	H		13.68	9.85		-13.00	
6692.80	---	H		11.95	10.74		-13.00	
7529.40	---	H		11.45	11.35		-13.00	
8366.00	---	H		11.59	12.43		-13.00	

Measurement uncertainty	30MHz - 80MHz: 5.04dB
	80MHz - 1000MHz: 3.76dB
	1GHz - 13GHz: 4.45dB

Remark :

- 1 The emission behaviors belong to narrowband spurious emission.
- 2 Remark"---" means that the emission level is too low to be measured
- 3 The result basic equation calculation is as follows:
- 4  $ERP/EIRP (dBm) = SG \text{ Setting}(dBm) + Antenna \text{ Gain} (dB/dBi) - Cable \text{ loss} (dB)$

Unless otherwise stated the results shown in this test report refer only to the sample(s) tested. This test report cannot be reproduced, except in full, without prior written permission of the Company. 除非另有說明，此報告結果僅對測試之樣品負責。本報告未經本公司書面許可，不可部份複製。

This Test Report is issued by the Company under its General Conditions of Service which is available on request or accessible at [http://www.sgs.com/terms\\_and\\_conditions.htm](http://www.sgs.com/terms_and_conditions.htm). Attention is drawn to the limitation of liability, indemnification and jurisdiction issues defined therein. Any holder of this Test Report is advised that information contained hereon reflects the Company's findings at the time of its intervention only and within the limits of Client's instructions, if any. The Company's sole responsibility is to its Client and this document does not exonerate parties to a transaction from exercising all their rights and obligations under the transaction documents. Any unauthorized alteration, forgery or falsification of the content or appearance of this document is unlawful and offenders may be prosecuted to the fullest extent of the law.

**Radiated Spurious Emission Measurement Result: GSM 850 Mode**

Operation Mode	: TX CH High E2 Mode	Test Date:	May.10,2008
Fundamental Frequency	: 848.80 MHz	Test By:	Duka
Temperature	: 25°C	Pol:	Ver
Humidity	: 65%		

Freq. (MHz)	SPA. Reading (dBuV)	Ant.Pol. H/V	S.G Out-put (dBm)	Antenna Gain (dB/dBi)	Cable Loss (dB)	ERP/EIRP (dBm)	Limit (dBm)	Safe Margin (dBm)
62.98	42.52	V	-68.93	-0.64	0.96	-70.54	-13.00	-57.54
92.08	41.86	V	-62.39	-7.75	1.17	-71.32	-13.00	-58.32
106.63	40.79	V	-62.10	-7.77	1.25	-71.12	-13.00	-58.12
150.28	36.15	V	-61.49	-7.80	1.47	-70.75	-13.00	-57.75
288.99	37.58	V	-62.25	-7.91	1.99	-72.15	-13.00	-59.15
850.00	75.74	V	-10.97	-7.88	3.75	-22.60	-13.00	-9.60
1697.60	47.62	V	-59.40	9.44	5.14	-55.11	-13.00	-42.11
2546.40	---	V		10.20	6.40		-13.00	
3395.20	---	V		12.38	7.33		-13.00	
4244.00	---	V		12.63	8.46		-13.00	
5092.80	---	V		12.74	9.32		-13.00	
5941.60	---	V		13.81	9.89		-13.00	
6790.40	---	V		11.86	10.87		-13.00	
7639.20	---	V		11.40	11.48		-13.00	
8488.00	---	V		11.70	12.59		-13.00	

Measurement uncertainty	30MHz - 80MHz: 5.04dB
	80MHz - 1000MHz: 3.76dB
	1GHz - 13GHz: 4.45dB

Remark :

- 1 The emission behaviors belong to narrowband spurious emission.
- 2 Remark"---" means that the emission level is too low to be measured
- 3 The result basic equation calculation is as follows:
- 4  $ERP/EIRP (dBm) = SG \text{ Setting}(dBm) + Antenna \text{ Gain} (dB/dBi) - Cable \text{ loss} (dB)$

Unless otherwise stated the results shown in this test report refer only to the sample(s) tested. This test report cannot be reproduced, except in full, without prior written permission of the Company. 除非另有說明，此報告結果僅對測試之樣品負責。本報告未經本公司書面許可，不可部份複製。  
 This Test Report is issued by the Company under its General Conditions of Service which is available on request or accessible at [http://www.sgs.com/terms\\_and\\_conditions.htm](http://www.sgs.com/terms_and_conditions.htm). Attention is drawn to the limitation of liability, indemnification and jurisdiction issues defined therein. Any holder of this Test Report is advised that information contained hereon reflects the Company's findings at the time of its intervention only and within the limits of Client's instructions, if any. The Company's sole responsibility is to its Client and this document does not exonerate parties to a transaction from exercising all their rights and obligations under the transaction documents. Any unauthorized alteration, forgery or falsification of the content or appearance of this document is unlawful and offenders may be prosecuted to the fullest extent of the law.



**Radiated Spurious Emission Measurement Result: PCS 1900 Mode**

Operation Mode	: TX CH Low E1 Mode	Test Date	May.10,2008
Fundamental Frequency	: 1850.20MHz	Test By:	Duka
Temperature	: 25°C	Pol:	Ver
Humidity	: 65%		

Freq. (MHz)	SPA. Reading (dBuV)	Ant.Pol. H/V	S.G Out-put (dBm)	Antenna Gain (dB/dBi)	Cable Loss (dB)	ERP/EIRP (dBm)	Limit (dBm)	Safe Margin (dBm)
36.79	50.35	V	-52.38	-4.16	0.75	-57.29	-13.00	-44.29
51.34	48.57	V	-59.01	-0.58	0.91	-60.49	-13.00	-47.49
101.78	43.60	V	-59.88	-7.76	1.23	-68.87	-13.00	-55.87
177.44	35.39	V	-64.68	-7.82	1.52	-74.03	-13.00	-61.03
290.93	37.73	V	-62.05	-7.91	1.99	-71.95	-13.00	-58.95
1850.00	81.96	V	-25.00	9.90	5.41	-20.51	-13.00	-7.51
3700.40	46.54	V	-55.04	12.61	7.73	-50.16	-13.00	-37.16
5550.60	---	V		13.23	9.68		-13.00	
7400.80	---	V		11.50	11.28		-13.00	
9251.00	---	V		11.92	13.10		-13.00	
11101.20	---	V		11.66	14.33		-13.00	
12951.40	---	V		13.63	15.98		-13.00	
14801.60	---	V		12.76	17.27		-13.00	
16651.80	---	V		15.92	19.04		-13.00	
18502.00	---	V		18.75	21.21		-13.00	

Measurement uncertainty	30MHz - 80MHz: 5.04dB
	80MHz - 1000MHz: 3.76dB
	1GHz - 13GHz: 4.45dB

Remark :

- 1 The emission behaviors belong to narrowband spurious emission.
- 2 Remark"---" means that the emission level is too low to be measured
- 3 The result basic equation calculation is as follows:
- 4  $ERP/EIRP (dBm) = SG \text{ Setting}(dBm) + Antenna \text{ Gain} (dB/dBi) - Cable \text{ loss} (dB)$

Unless otherwise stated the results shown in this test report refer only to the sample(s) tested. This test report cannot be reproduced, except in full, without prior written permission of the Company. 除非另有說明，此報告結果僅對測試之樣品負責。本報告未經本公司書面許可，不可部份複製。  
 This Test Report is issued by the Company under its General Conditions of Service which is available on request or accessible at [http://www.sgs.com/terms\\_and\\_conditions.htm](http://www.sgs.com/terms_and_conditions.htm). Attention is drawn to the limitation of liability, indemnification and jurisdiction issues defined therein. Any holder of this Test Report is advised that information contained hereon reflects the Company's findings at the time of its intervention only and within the limits of Client's instructions, if any. The Company's sole responsibility is to its Client and this document does not exonerate parties to a transaction from exercising all their rights and obligations under the transaction documents. Any unauthorized alteration, forgery or falsification of the content or appearance of this document is unlawful and offenders may be prosecuted to the fullest extent of the law.

**Radiated Spurious Emission Measurement Result: PCS 1900 Mode**

Operation Mode	: TX CH Low E1 Mode	Test Date	May.10,2008
Fundamental Frequency	: 1850.20MHz	Test By:	Duka
Temperature	: 25°C	Pol:	Hor
Humidity	: 65%		

Freq. (MHz)	SPA Reading (dBuV)	Ant.Pol. H/V	S.G Out-put (dBm)	Antenna Gain (dB/dBi)	Cable Loss (dB)	ERP/EIRP (dBm)	Limit (dBm)	Safe Margin (dBm)
38.73	56.64	H	-46.55	-3.25	0.77	-50.57	-13.00	-37.57
67.83	46.54	H	-65.52	-0.95	1.00	-67.46	-13.00	-54.46
101.78	43.32	H	-59.72	-7.76	1.23	-68.70	-13.00	-55.70
138.64	37.63	H	-62.00	-7.79	1.41	-71.20	-13.00	-58.20
177.44	35.88	H	-64.47	-7.82	1.52	-73.81	-13.00	-60.81
1850.00	82.31	H	-24.58	9.90	5.41	-20.09	-13.00	-7.09
3700.40	44.27	H	-57.09	12.61	7.73	-52.21	-13.00	-39.21
5550.60	---	H		13.23	9.68		-13.00	
7400.80	---	H		11.50	11.28		-13.00	
9251.00	---	H		11.92	13.10		-13.00	
11101.20	---	H		11.66	14.33		-13.00	
12951.40	---	H		13.63	15.98		-13.00	
14801.60	---	H		12.76	17.27		-13.00	
16651.80	---	H		15.92	19.04		-13.00	
18502.00	---	H		18.75	21.21		-13.00	

Measurement uncertainty	30MHz - 80MHz: 5.04dB
	80MHz -1000MHz: 3.76dB
	1GHz - 13GHz: 4.45dB

Remark :

- 1 The emission behaviors belong to narrowband spurious emission.
- 2 Remark"---" means that the emission level is too low to be measured
- 3 The result basic equation calculation is as follows:
- 4 ERP/EIRP (dBm) = SG Setting(dBm) + Antenna Gain (dB/dBi) – Cable loss (dB)

Unless otherwise stated the results shown in this test report refer only to the sample(s) tested. This test report cannot be reproduced, except in full, without prior written permission of the Company. 除非另有說明，此報告結果僅對測試之樣品負責。本報告未經本公司書面許可，不可部份複製。  
 This Test Report is issued by the Company under its General Conditions of Service which is available on request or accessible at [http://www.sgs.com/terms\\_and\\_conditions.htm](http://www.sgs.com/terms_and_conditions.htm). Attention is drawn to the limitation of liability, indemnification and jurisdiction issues defined therein. Any holder of this Test Report is advised that information contained hereon reflects the Company's findings at the time of its intervention only and within the limits of Client's instructions, if any. The Company's sole responsibility is to its Client and this document does not exonerate parties to a transaction from exercising all their rights and obligations under the transaction documents. Any unauthorized alteration, forgery or falsification of the content or appearance of this document is unlawful and offenders may be prosecuted to the fullest extent of the law.

**Radiated Spurious Emission Measurement Result: PCS 1900 Mode**

Operation Mode	: TX CH Mid E1 Mode	Test Date	May.10,2008
Fundamental Frequency	: 1880MHz	Test By	Duka
Temperature	: 25°C	Pol	Ver
Humidity	: 65%		

Freq. (MHz)	SPA. Reading (dBuV)	Ant.Pol. H/V	S.G Out-put (dBm)	Antenna Gain (dB/dBi)	Cable Loss (dB)	ERP/EIRP (dBm)	Limit (dBm)	Safe Margin (dBm)
38.73	57.08	V	-45.09	-3.25	0.77	-49.11	-13.00	-36.11
61.04	43.58	V	-67.77	-0.52	0.95	-69.25	-13.00	-56.25
101.78	44.57	V	-58.91	-7.76	1.23	-67.90	-13.00	-54.90
177.44	35.39	V	-64.68	-7.82	1.52	-74.03	-13.00	-61.03
288.99	35.95	V	-63.88	-7.91	1.99	-73.78	-13.00	-60.78
3760.00	45.36	V	-55.94	12.60	7.82	-51.16	-13.00	-38.16
5640.00	---	V		13.36	9.73		-13.00	
5634.00	---	V		13.35	9.73		-13.00	
7520.00	---	V		11.45	11.33		-13.00	
9400.00	---	V		11.93	13.15		-13.00	
11280.00	---	V		11.92	14.56		-13.00	
13160.00	---	V		13.33	16.11		-13.00	
15040.00	---	V		13.76	17.57		-13.00	
16920.00	---	V		15.27	19.66		-13.00	
18800.00	---	V		18.68	21.34		-13.00	

Measurement uncertainty	30MHz - 80MHz: 5.04dB
	80MHz -1000MHz: 3.76dB
	1GHz - 13GHz: 4.45dB

Remark :

- 1 The emission behaviors belong to narrowband spurious emission.
- 2 Remark"---" means that the emission level is too low to be measured
- 3 The result basic equation calculation is as follows:
- 4  $ERP/EIRP (dBm) = SG \text{ Setting}(dBm) + Antenna \text{ Gain} (dB/dBi) - Cable \text{ loss} (dB)$

Unless otherwise stated the results shown in this test report refer only to the sample(s) tested. This test report cannot be reproduced, except in full, without prior written permission of the Company. 除非另有說明，此報告結果僅對測試之樣品負責。本報告未經本公司書面許可，不可部份複製。  
 This Test Report is issued by the Company under its General Conditions of Service which is available on request or accessible at [http://www.sgs.com/terms\\_and\\_conditions.htm](http://www.sgs.com/terms_and_conditions.htm). Attention is drawn to the limitation of liability, indemnification and jurisdiction issues defined therein. Any holder of this Test Report is advised that information contained hereon reflects the Company's findings at the time of its intervention only and within the limits of Client's instructions, if any. The Company's sole responsibility is to its Client and this document does not exonerate parties to a transaction from exercising all their rights and obligations under the transaction documents. Any unauthorized alteration, forgery or falsification of the content or appearance of this document is unlawful and offenders may be prosecuted to the fullest extent of the law.

**Radiated Spurious Emission Measurement Result: PCS 1900 Mode**

Operation Mode	: TX CH Mid E1 Mode	Test Date	May.10,2008
Fundamental Frequency	: 1880MHz	Test By	Duka
Temperature	: 25°C	Pol	Hor
Humidity	: 65%		

Freq. (MHz)	SPA. Reading (dBuV)	Ant.Pol. H/V	S.G Out-put (dBm)	Antenna Gain (dB/dBi)	Cable Loss (dB)	ERP/EIRP (dBm)	Limit (dBm)	Safe Margin (dBm)
67.83	50.02	H	-62.04	-0.95	1.00	-63.98	-13.00	-50.98
101.78	44.52	H	-58.52	-7.76	1.23	-67.50	-13.00	-54.50
138.64	38.86	H	-60.77	-7.79	1.41	-69.97	-13.00	-56.97
177.44	35.70	H	-64.65	-7.82	1.52	-73.99	-13.00	-60.99
402.48	34.42	H	-61.87	-7.66	2.42	-71.96	-13.00	-58.96
3760.00	47.15	H	-53.96	12.60	7.82	-49.17	-13.00	-36.17
5640.00	---	H		13.36	9.73		-13.00	
7520.00	---	H		11.45	11.33		-13.00	
9400.00	---	H		11.93	13.15		-13.00	
11280.00	---	H		11.92	14.56		-13.00	
13160.00	---	H		13.33	16.11		-13.00	
15040.00	---	H		13.76	17.57		-13.00	
16920.00	---	H		15.27	19.66		-13.00	
18800.00	---	H		18.68	21.34		-13.00	

Measurement uncertainty	30MHz - 80MHz: 5.04dB
	80MHz -1000MHz: 3.76dB
	1GHz - 13GHz: 4.45dB

Remark :

- 1 The emission behaviors belong to narrowband spurious emission.
- 2 Remark"---" means that the emission level is too low to be measured
- 3 The result basic equation calculation is as follows:
- 4  $ERP/EIRP (dBm) = SG \text{ Setting}(dBm) + Antenna \text{ Gain} (dB/dBi) - Cable \text{ loss} (dB)$

Unless otherwise stated the results shown in this test report refer only to the sample(s) tested. This test report cannot be reproduced, except in full, without prior written permission of the Company. 除非另有說明，此報告結果僅對測試之樣品負責。本報告未經本公司書面許可，不可部份複製。  
 This Test Report is issued by the Company under its General Conditions of Service which is available on request or accessible at [http://www.sgs.com/terms\\_and\\_conditions.htm](http://www.sgs.com/terms_and_conditions.htm). Attention is drawn to the limitation of liability, indemnification and jurisdiction issues defined therein. Any holder of this Test Report is advised that information contained hereon reflects the Company's findings at the time of its intervention only and within the limits of Client's instructions, if any. The Company's sole responsibility is to its Client and this document does not exonerate parties to a transaction from exercising all their rights and obligations under the transaction documents. Any unauthorized alteration, forgery or falsification of the content or appearance of this document is unlawful and offenders may be prosecuted to the fullest extent of the law.



**Radiated Spurious Emission Measurement Result: PCS 1900 Mode**

Operation Mode	: TX CH High E1 Mode	Test Date	May.10,2008
Fundamental Frequency	: 1909.8 MHz	Test By	Duka
Temperature	: 25°C	Pol	Ver
Humidity	: 65%		

Freq. (MHz)	SPA. Reading (dBuV)	Ant.Pol. H/V	S.G Out-put (dBm)	Antenna Gain (dB/dBi)	Cable Loss (dB)	ERP/EIRP (dBm)	Limit (dBm)	Safe Margin (dBm)
38.73	53.91	V	-48.26	-3.25	0.77	-52.28	-13.00	-39.28
72.68	47.66	V	-64.01	-1.45	1.03	-66.49	-13.00	-53.49
101.78	44.53	V	-58.95	-7.76	1.23	-67.94	-13.00	-54.94
177.44	35.76	V	-64.31	-7.82	1.52	-73.66	-13.00	-60.66
288.99	35.71	V	-64.12	-7.91	1.99	-74.02	-13.00	-61.02
1910.00	84.97	V	-21.97	10.08	5.51	-17.40	-13.00	-4.40
3819.60	44.26	V	-56.77	12.60	7.92	-52.08	-13.00	-39.08
5729.40	---	V		13.49	9.78		-13.00	
7639.20	---	V		11.40	11.48		-13.00	
9549.00	---	V		11.95	13.22		-13.00	
11458.80	---	V		12.17	14.79		-13.00	
13368.60	---	V		12.97	16.22		-13.00	
15278.40	---	V		15.00	17.88		-13.00	
17188.20	---	V		14.47	19.75		-13.00	
19098.00	---	V		18.66	21.36		-13.00	

Measurement uncertainty	30MHz - 80MHz: 5.04dB
	80MHz - 1000MHz: 3.76dB
	1GHz - 13GHz: 4.45dB

Remark :

- 1 The emission behaviors belong to narrowband spurious emission.
- 2 Remark"---" means that the emission level is too low to be measured
- 3 The result basic equation calculation is as follows:
- 4  $ERP/EIRP (dBm) = SG \text{ Setting}(dBm) + Antenna \text{ Gain} (dB/dBi) - Cable \text{ loss} (dB)$

Unless otherwise stated the results shown in this test report refer only to the sample(s) tested. This test report cannot be reproduced, except in full, without prior written permission of the Company. 除非另有說明，此報告結果僅對測試之樣品負責。本報告未經本公司書面許可，不可部份複製。  
 This Test Report is issued by the Company under its General Conditions of Service which is available on request or accessible at [http://www.sgs.com/terms\\_and\\_conditions.htm](http://www.sgs.com/terms_and_conditions.htm). Attention is drawn to the limitation of liability, indemnification and jurisdiction issues defined therein. Any holder of this Test Report is advised that information contained hereon reflects the Company's findings at the time of its intervention only and within the limits of Client's instructions, if any. The Company's sole responsibility is to its Client and this document does not exonerate parties to a transaction from exercising all their rights and obligations under the transaction documents. Any unauthorized alteration, forgery or falsification of the content or appearance of this document is unlawful and offenders may be prosecuted to the fullest extent of the law.

**Radiated Spurious Emission Measurement Result: PCS 1900 Mode**

Operation Mode	: TX CH High E1 Mode	Test Date	May.10,2008
Fundamental Frequency	: 1909.8 MHz	Test By	Duka
Temperature	: 25°C	Pol	Hor
Humidity	: 65%		

Freq. (MHz)	SPA. Reading (dBuV)	Ant.Pol. H/V	S.G Out-put (dBm)	Antenna Gain (dB/dBi)	Cable Loss (dB)	ERP/EIRP (dBm)	Limit (dBm)	Safe Margin (dBm)
67.83	50.22	H	-61.84	-0.95	1.00	-63.78	-13.00	-50.78
101.78	44.72	H	-58.32	-7.76	1.23	-67.30	-13.00	-54.30
155.13	37.46	H	-61.45	-7.80	1.48	-70.73	-13.00	-57.73
177.44	35.65	H	-64.70	-7.82	1.52	-74.04	-13.00	-61.04
288.99	36.12	H	-63.77	-7.91	1.99	-73.67	-13.00	-60.67
1910.00	81.04	H	-25.81	10.08	5.51	-21.25	-13.00	-8.25
3819.60	44.45	H	-56.41	12.60	7.92	-51.72	-13.00	-38.72
5729.40	---	H		13.49	9.78		-13.00	
7639.20	---	H		11.40	11.48		-13.00	
9549.00	---	H		11.95	13.22		-13.00	
11458.80	---	H		12.17	14.79		-13.00	
13368.60	---	H		12.97	16.22		-13.00	
15278.40	---	H		15.00	17.88		-13.00	
17188.20	---	H		14.47	19.75		-13.00	
19098.00	---	H		18.66	21.36		-13.00	

Measurement uncertainty	30MHz - 80MHz: 5.04dB
	80MHz - 1000MHz: 3.76dB
	1GHz - 13GHz: 4.45dB

Remark :

- 1 The emission behaviors belong to narrowband spurious emission.
- 2 Remark"---" means that the emission level is too low to be measured
- 3 The result basic equation calculation is as follows:
- 4  $ERP/EIRP (dBm) = SG \text{ Setting}(dBm) + Antenna \text{ Gain} (dB/dBi) - Cable \text{ loss} (dB)$

Unless otherwise stated the results shown in this test report refer only to the sample(s) tested. This test report cannot be reproduced, except in full, without prior written permission of the Company. 除非另有說明，此報告結果僅對測試之樣品負責。本報告未經本公司書面許可，不可部份複製。  
 This Test Report is issued by the Company under its General Conditions of Service which is available on request or accessible at [http://www.sgs.com/terms\\_and\\_conditions.htm](http://www.sgs.com/terms_and_conditions.htm). Attention is drawn to the limitation of liability, indemnification and jurisdiction issues defined therein. Any holder of this Test Report is advised that information contained hereon reflects the Company's findings at the time of its intervention only and within the limits of Client's instructions, if any. The Company's sole responsibility is to its Client and this document does not exonerate parties to a transaction from exercising all their rights and obligations under the transaction documents. Any unauthorized alteration, forgery or falsification of the content or appearance of this document is unlawful and offenders may be prosecuted to the fullest extent of the law.

## 10.10 FREQUENCY STABILITY V.S. TEMPERATURE MEASUREMENT

### 10.1 Standard Applicable

According to FCC §2.1055(a)(1)(b).

Frequency Tolerance: +/-0.1 ppm for 850MHz band

+/-0.04 ppm for 1900MHz band

### 10.2 Test Set-up:

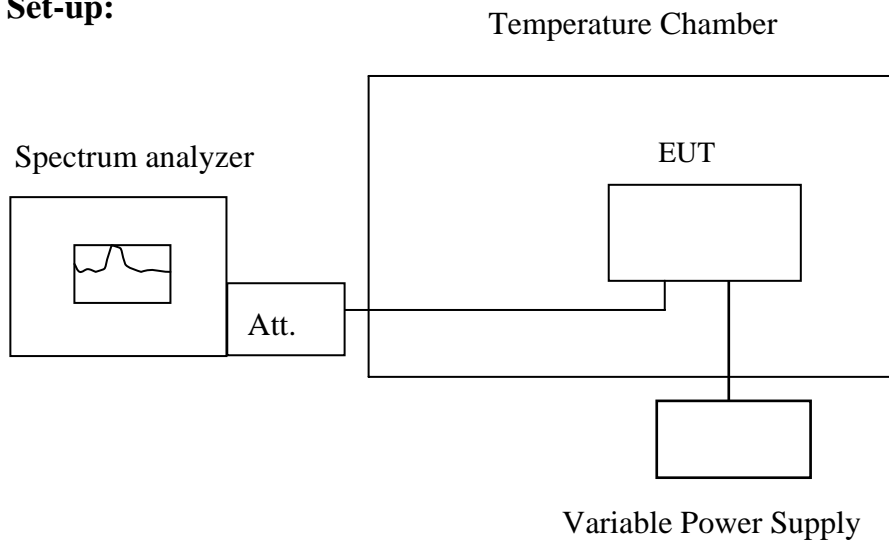

**Note :** Measurement setup for testing on Antenna connector

### 10.3 Measurement Procedure

The equipment under test was connected to an external AC or DC power supply and input rated voltage. RF output was connected to a frequency counter or spectrum analyzer via feed through attenuators. The EUT was placed inside the temperature chamber. Set the spectrum analyzer RBW low enough to obtain the desired frequency resolution and measure EUT 25°C operating frequency as reference frequency. Turn EUT off and set the chamber temperature to -30°C. After the temperature stabilized for approximately 30 minutes re-recorded the frequency. Repeat step measure with 10°C increased per stage until the highest temperature of +50°C reached.

Unless otherwise stated the results shown in this test report refer only to the sample(s) tested. This test report cannot be reproduced, except in full, without prior written permission of the Company. 除非另有說明，此報告結果僅對測試之樣品負責。本報告未經本公司書面許可，不可部份複製。

This Test Report is issued by the Company under its General Conditions of Service which is available on request or accessible at [http://www.sgs.com/terms\\_and\\_conditions.htm](http://www.sgs.com/terms_and_conditions.htm). Attention is drawn to the limitation of liability, indemnification and jurisdiction issues defined therein. Any holder of this Test Report is advised that information contained hereon reflects the Company's findings at the time of its intervention only and within the limits of Client's instructions, if any. The Company's sole responsibility is to its Client and this document does not exonerate parties to a transaction from exercising all their rights and obligations under the transaction documents. Any unauthorized alteration, forgery or falsification of the content or appearance of this document is unlawful and offenders may be prosecuted to the fullest extent of the law.

**10.4 Measurement Equipment Used:**

Conducted Emission Test Site					
EQUIPMENT TYPE	MFR	MODEL NUMBER	SERIAL NUMBER	LAST CAL.	CAL DUE.
Spectrum Analyzer	Agilent	E4446A	MY43360126	04/27/2008	04/26/2009
Spectrum Analyzer	Agilent	7405A	US41160416	06/28/2008	06/29/2009
Power Sensor	Anritsu	MA2490A	31431	06/28/2008	06/29/2009
Power Meter	Anritsu	ML2487A	6K00002070	06/28/2008	06/29/2009
Temperature Chamber	TERCHY	MHG-120LF	911009	11/11/2007	11/12/2008
Low Loss Cable	HUBER+SUHNER	SUCOFLEX 104PEA	N/A	N/A	N/A
Attenuator	Mini-Circuit	BW-S10W5	N/A	10/07/2007	10/06/2008
Attenuator	Mini-Circuit	BW-S6W5	N/A	10/07/2007	10/06/2008
Splitter	Agilent	11636B	51728	09/23/2007	9/22/2008
Signal Generator	R&S	SMR40	100210	11/09/2007	11/10/2008
DC Power Supply	Agilent	6038A	2929A-07548	01/06/2008	01/05/2009

Unless otherwise stated the results shown in this test report refer only to the sample(s) tested. This test report cannot be reproduced, except in full, without prior written permission of the Company. 除非另有說明，此報告結果僅對測試之樣品負責。本報告未經本公司書面許可，不可部份複製。  
 This Test Report is issued by the Company under its General Conditions of Service which is available on request or accessible at [http://www.sgs.com/terms\\_and\\_conditions.htm](http://www.sgs.com/terms_and_conditions.htm). Attention is drawn to the limitation of liability, indemnification and jurisdiction issues defined therein. Any holder of this Test Report is advised that information contained hereon reflects the Company's findings at the time of its intervention only and within the limits of Client's instructions, if any. The Company's sole responsibility is to its Client and this document does not exonerate parties to a transaction from exercising all their rights and obligations under the transaction documents. Any unauthorized alteration, forgery or falsification of the content or appearance of this document is unlawful and offenders may be prosecuted to the fullest extent of the law.

### 10.5 Measurement Result

Reference Frequency: GSM Mid Channel 836.6 MHz @ 25°C				
Limit: +/- 0.1 ppm = 83.6 Hz				
Power Supply	Environment	Frequency	Delta (Hz)	Limit (Hz)
Vdc	Temperature (°C)	(MHz)		
3.7	-30	836.600014	-15.00	83.6
3.7	-20	836.600009	-10.00	83.6
3.7	-10	836.600023	-24.00	83.6
3.7	0	836.599998	1.00	83.6
3.7	10	836.599974	25.00	83.6
3.7	20	836.599999	0.00	83.6
3.7	30	836.600002	-3.00	83.6
3.7	40	836.599986	13.00	83.6
3.7	50	836.600007	-8.00	83.6

Reference Frequency: PCS Mid Channel 1880 MHz @ 25°C				
Limit: +/- 0.04 ppm = 75.2 Hz				
Power Supply	Environment	Frequency	Delta (Hz)	Limit (Hz)
Vdc	Temperature (°C)	(MHz)		
3.7	-30	1879.999948	35.00	75.2
3.7	-20	1879.999932	51.00	75.2
3.7	-10	1879.999956	27.00	75.2
3.7	0	1879.999919	64.00	75.2
3.7	10	1879.999951	32.00	75.2
3.7	20	1879.999983	0.00	75.2
3.7	30	1879.999914	69.00	75.2
3.7	40	1879.999911	72.00	75.2
3.7	50	1879.999994	-11.00	75.2

**Note: The battery is rated 3.7V dc.**

Unless otherwise stated the results shown in this test report refer only to the sample(s) tested. This test report cannot be reproduced, except in full, without prior written permission of the Company. 除非另有說明，此報告結果僅對測試之樣品負責。本報告未經本公司書面許可，不可部份複製。  
 This Test Report is issued by the Company under its General Conditions of Service which is available on request or accessible at [http://www.sgs.com/terms\\_and\\_conditions.htm](http://www.sgs.com/terms_and_conditions.htm). Attention is drawn to the limitation of liability, indemnification and jurisdiction issues defined therein. Any holder of this Test Report is advised that information contained hereon reflects the Company's findings at the time of its intervention only and within the limits of Client's instructions, if any. The Company's sole responsibility is to its Client and this document does not exonerate parties to a transaction from exercising all their rights and obligations under the transaction documents. Any unauthorized alteration, forgery or falsification of the content or appearance of this document is unlawful and offenders may be prosecuted to the fullest extent of the law.

## 11 FREQUENCY STABILITY V.S. VOLTAGE MEASUREMENT

### 11.1 Standard Applicable

According to FCC §2.1055(d)(1)(2)

Frequency Tolerance: +/-0.1ppm for 850MHz band  
 +/-0.04ppm for 1900MHz band

### 11.2 Test Set-up:

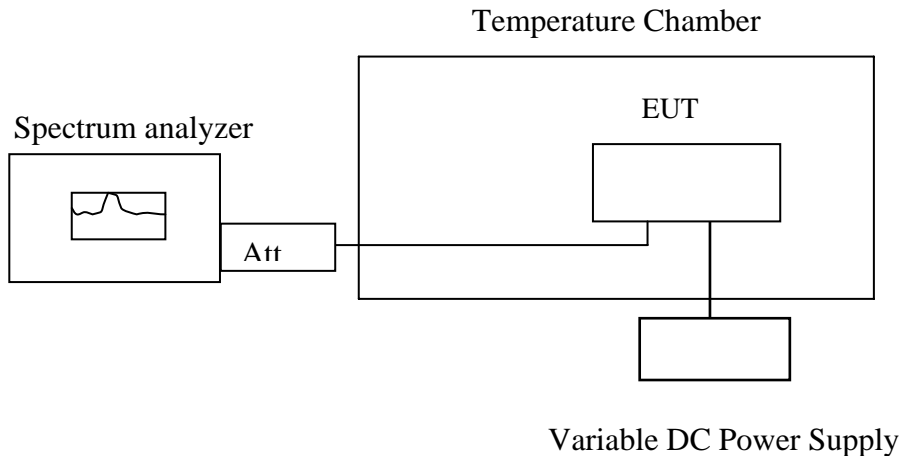

*Note: Measurement setup for testing on Antenna connector*

### 11.3 Measurement Procedure

Set chamber temperature to 25°C. Use a variable AC power supply / DC power source to power the EUT and set the voltage to rated voltage. Set the spectrum analyzer RBW low enough to obtain the desired frequency resolution and recorded the frequency.

Reduce the input voltage to specified extreme voltage variation (+/- 15%) and endpoint, record the maximum frequency change.

Unless otherwise stated the results shown in this test report refer only to the sample(s) tested. This test report cannot be reproduced, except in full, without prior written permission of the Company. 除非另有說明，此報告結果僅對測試之樣品負責。本報告未經本公司書面許可，不可部份複製。

This Test Report is issued by the Company under its General Conditions of Service which is available on request or accessible at [http://www.sgs.com/terms\\_and\\_conditions.htm](http://www.sgs.com/terms_and_conditions.htm). Attention is drawn to the limitation of liability, indemnification and jurisdiction issues defined therein. Any holder of this Test Report is advised that information contained hereon reflects the Company's findings at the time of its intervention only and within the limits of Client's instructions, if any. The Company's sole responsibility is to its Client and this document does not exonerate parties to a transaction from exercising all their rights and obligations under the transaction documents. Any unauthorized alteration, forgery or falsification of the content or appearance of this document is unlawful and offenders may be prosecuted to the fullest extent of the law.

**11.4 Measurement Equipment Used:**

Conducted Emission Test Site					
EQUIPMENT TYPE	MFR	MODEL NUMBER	SERIAL NUMBER	LAST CAL.	CAL DUE.
Spectrum Analyzer	Agilent	E4446A	MY43360126	04/27/2008	04/26/2009
Spectrum Analyzer	Agilent	7405A	US41160416	06/28/2008	06/29/2009
Power Sensor	Anritsu	MA2490A	31431	06/28/2008	06/29/2009
Power Meter	Anritsu	ML2487A	6K00002070	06/28/2008	06/29/2009
Temperature Chamber	TERCHY	MHG-120LF	911009	11/11/2007	11/12/2008
Low Loss Cable	HUBER+SUHNER	SUCOFLEX 104PEA	N/A	N/A	N/A
Attenuator	Mini-Circuit	BW-S10W5	N/A	10/07/2007	10/06/2008
Attenuator	Mini-Circuit	BW-S6W5	N/A	10/07/2007	10/06/2008
Splitter	Agilent	11636B	51728	09/23/2007	9/22/2008
Signal Generator	R&S	SMR40	100210	11/09/2007	11/10/2008
DC Power Supply	Agilent	6038A	2929A-07548	01/06/2008	01/05/2009

Unless otherwise stated the results shown in this test report refer only to the sample(s) tested. This test report cannot be reproduced, except in full, without prior written permission of the Company. 除非另有說明，此報告結果僅對測試之樣品負責。本報告未經本公司書面許可，不可部份複製。

This Test Report is issued by the Company under its General Conditions of Service which is available on request or accessible at [http://www.sgs.com/terms\\_and\\_conditions.htm](http://www.sgs.com/terms_and_conditions.htm). Attention is drawn to the limitation of liability, indemnification and jurisdiction issues defined therein. Any holder of this Test Report is advised that information contained hereon reflects the Company's findings at the time of its intervention only and within the limits of Client's instructions, if any. The Company's sole responsibility is to its Client and this document does not exonerate parties to a transaction from exercising all their rights and obligations under the transaction documents. Any unauthorized alteration, forgery or falsification of the content or appearance of this document is unlawful and offenders may be prosecuted to the fullest extent of the law.

### 11.5 Measurement Result

Reference Frequency: GSM Mid Channel 836.6 MHz @ 25°C				
Limit: +/- 0.1 ppm = 83.6 Hz				
Power Supply	Environment	Frequency	Delta (Hz)	Limit (Hz)
Vdc	Temperature (°C)	(MHz)		
4.20	25.00	836.600008	0.00	83.6
3.70	25.00	836.599997	11.00	83.6
3.10	25.00	836.600013	-5.00	83.6
2.90 (End Point)	25.00	836.599984	24.00	83.6

Reference Frequency: PCS Mid Channel 1880 MHz @ 25°C				
Limit: +/- 0.04 ppm = 75.2 Hz				
Power Supply	Environment	Frequency	Delta (Hz)	Limit (Hz)
Vdc	Temperature (°C)	(MHz)		
4.20	25	1879.999945	0.00	75.2
3.70	25	1879.999973	-28.00	75.2
3.10	25	1879.999931	14.00	75.2
2.90 (Endpoint)	25	1879.999904	41.00	75.2

**Note: The battery is rated 3.7V dc.**

Unless otherwise stated the results shown in this test report refer only to the sample(s) tested. This test report cannot be reproduced, except in full, without prior written permission of the Company. 除非另有說明，此報告結果僅對測試之樣品負責。本報告未經本公司書面許可，不可部份複製。  
 This Test Report is issued by the Company under its General Conditions of Service which is available on request or accessible at [http://www.sgs.com/terms\\_and\\_conditions.htm](http://www.sgs.com/terms_and_conditions.htm). Attention is drawn to the limitation of liability, indemnification and jurisdiction issues defined therein. Any holder of this Test Report is advised that information contained hereon reflects the Company's findings at the time of its intervention only and within the limits of Client's instructions, if any. The Company's sole responsibility is to its Client and this document does not exonerate parties to a transaction from exercising all their rights and obligations under the transaction documents. Any unauthorized alteration, forgery or falsification of the content or appearance of this document is unlawful and offenders may be prosecuted to the fullest extent of the law.



## 12 AC POWER LINE CONDUCTED EMISSION TEST

### 12.1 Standard Applicable

According to §15.207. The emission value for frequency within 150KHz to 30MHz shall not exceed criteria of below chart.

Frequency range MHz	Limits dB(uV)	
	Quasi-peak	Average
0.15 to 0.50	66 to 56	56 to 46
0.50 to 5	56	46
5 to 30	60	50

Note

- 1.The lower limit shall apply at the transition frequencies
- 2.The limit decreases linearly with the logarithm of the frequency in the range 0.15 MHz to 0.50 MHz.

### 12.2 EUT Setup

- 1.The conducted emission tests were performed in the test site, using the setup in accordance with the ANSI C63.4-2001.
- 2.The EUT was plug-in DC power adaptor and was placed on the center of the back edge on the test table. The peripherals like earphone was placed on the side of the EUT. The rear of the EUT and peripherals were placed flushed with the rear of the tabletop.
- 3.The Power adaptor was connected with 110Vac/60Hz power source.

### 12.3 Measurement Procedure

1. The EUT was placed on a table which is 0.8m above ground plane.
2. Maximum procedure was performed on the six highest emissions to ensure EUT compliance.
3. Repeat above procedures until all frequency measured were complete.

Unless otherwise stated the results shown in this test report refer only to the sample(s) tested. This test report cannot be reproduced, except in full, without prior written permission of the Company. 除非另有說明，此報告結果僅對測試之樣品負責。本報告未經本公司書面許可，不可部份複製。

This Test Report is issued by the Company under its General Conditions of Service which is available on request or accessible at [http://www.sgs.com/terms\\_and\\_conditions.htm](http://www.sgs.com/terms_and_conditions.htm). Attention is drawn to the limitation of liability, indemnification and jurisdiction issues defined therein. Any holder of this Test Report is advised that information contained hereon reflects the Company's findings at the time of its intervention only and within the limits of Client's instructions, if any. The Company's sole responsibility is to its Client and this document does not exonerate parties to a transaction from exercising all their rights and obligations under the transaction documents. Any unauthorized alteration, forgery or falsification of the content or appearance of this document is unlawful and offenders may be prosecuted to the fullest extent of the law.

### 12.4 Measurement Equipment Used:

Conducted Emission Test Site					
EQUIPMENT TYPE	MFR	MODEL NUMBER	SERIAL NUMBER	LAST CAL.	CAL DUE.
EMC Analyzer	HP	8594EM	3624A00203	09/02/2007	09/03/2008
EMI Test Receiver	R&S	ESCS30	828985/004	06/09/2008	06/08/2009
Transient Limiter	HP	11947A	3107A02062	09/02/2007	09/03/2008
LISN	Rolf-Heine	NNB-2/16Z	99012	12/31/2007	12/30/2008
LISN	Rolf-Heine	NNB-2/16Z	99013	12/24/2007	12/23/2008
LISN	FCC	50/250-25-2-01	04034	01/24/2008	01/23/2009
Coaxial Cables	N/A	No. 3, 4	N/A	12/24/2007	12/23/2008

### 12.5 Measurement Result

The initial step in collecting conducted data is a spectrum analyzer peak scan of the measurement range. Significant peaks are then marked as shown on the following data page, and these signals are then quasi-peaked.

Unless otherwise stated the results shown in this test report refer only to the sample(s) tested. This test report cannot be reproduced, except in full, without prior written permission of the Company. 除非另有說明，此報告結果僅對測試之樣品負責。本報告未經本公司書面許可，不可部份複製。  
 This Test Report is issued by the Company under its General Conditions of Service which is available on request or accessible at [http://www.sgs.com/terms\\_and\\_conditions.htm](http://www.sgs.com/terms_and_conditions.htm). Attention is drawn to the limitation of liability, indemnification and jurisdiction issues defined therein. Any holder of this Test Report is advised that information contained hereon reflects the Company's findings at the time of its intervention only and within the limits of Client's instructions, if any. The Company's sole responsibility is to its Client and this document does not exonerate parties to a transaction from exercising all their rights and obligations under the transaction documents. Any unauthorized alteration, forgery or falsification of the content or appearance of this document is unlawful and offenders may be prosecuted to the fullest extent of the law.

### AC POWER LINE CONDUCTED EMISSION TEST DATA

Operation Mode:	GSM 850 LINK		Test Date:	May.14,2008	
Temperature:	25 °C	Humidity:	62%	Test By:	Duka
Adaptor:	T5002684AGAB				

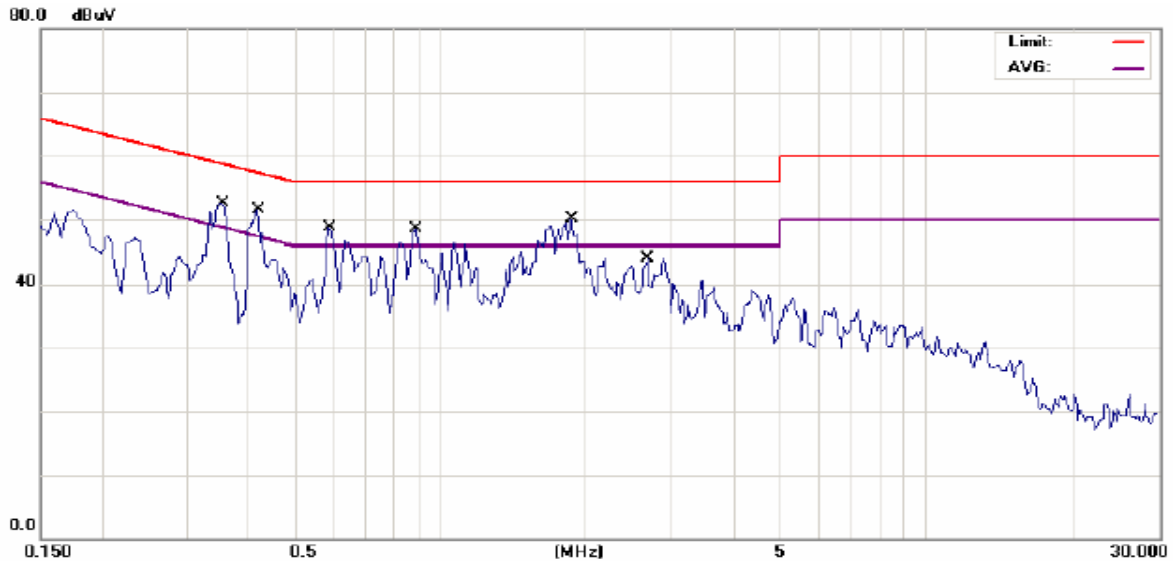

Site	SGS CONDUCTED #1	Phase:	L1	Temperature:	26 °C
Limit:	CISPR22/11 Class B Conduction(QP)	Power:	AC 120V/60Hz	Humidity:	58 %
EUT:	Mobile Phone	Distance:		Air Pressure:	hpa
M/N:	OT-S210A				
Note:	GSM 850 LINK				

No.	Mk.	Freq. MHz	Reading Level dBuV	Factor dB	Measure- ment dBuV	Limit dBuV	Over dB	Detector	Comment
1	*	0.3550	51.40	0.11	51.51	58.84	-7.33	QP	
2		0.3550	39.60	0.11	39.71	48.84	-9.13	AVG	
3		0.4200	49.70	0.08	49.78	57.45	-7.67	QP	
4		0.4200	37.90	0.08	37.98	47.45	-9.47	AVG	
5		0.5900	47.80	0.06	47.86	56.00	-8.14	QP	
6		0.5900	30.80	0.06	30.86	46.00	-15.14	AVG	
7		0.8900	42.36	0.04	42.40	56.00	-13.60	QP	
8		0.8900	31.06	0.04	31.10	46.00	-14.90	AVG	
9		1.8650	40.80	0.04	40.84	56.00	-15.16	QP	
10		1.8650	22.90	0.04	22.94	46.00	-23.06	AVG	
11		2.6900	41.57	0.04	41.61	56.00	-14.39	QP	
12		2.6900	33.42	0.04	33.46	46.00	-12.54	AVG	

Unless otherwise stated the results shown in this test report refer only to the sample(s) tested. This test report cannot be reproduced, except in full, without prior written permission of the Company. 除非另有說明，此報告結果僅對測試之樣品負責。本報告未經本公司書面許可，不可部份複製。  
 This Test Report is issued by the Company under its General Conditions of Service which is available on request or accessible at [http://www.sgs.com/terms\\_and\\_conditions.htm](http://www.sgs.com/terms_and_conditions.htm). Attention is drawn to the limitation of liability, indemnification and jurisdiction issues defined therein. Any holder of this Test Report is advised that information contained hereon reflects the Company's findings at the time of its intervention only and within the limits of Client's instructions, if any. The Company's sole responsibility is to its Client and this document does not exonerate parties to a transaction from exercising all their rights and obligations under the transaction documents. Any unauthorized alteration, forgery or falsification of the content or appearance of this document is unlawful and offenders may be prosecuted to the fullest extent of the law.

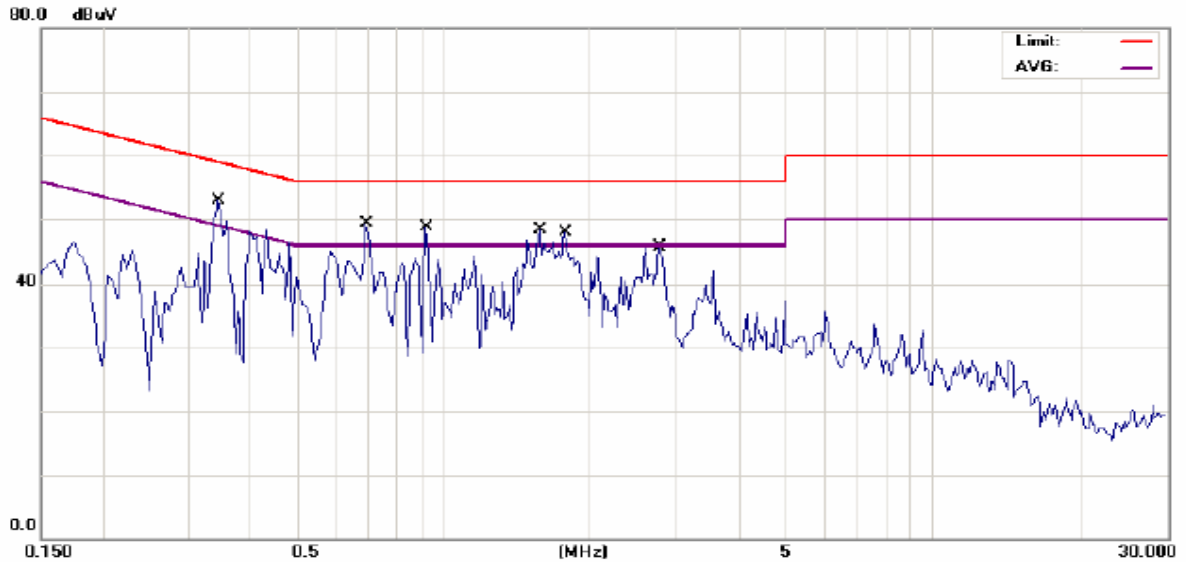

Site SGS CONDUCTED #1

Limit: CISPR22/11 Class B Conduction(QP)

EUT: Mobile Phone

M/N: OT-S210A

Note: GSM 850 LINK

Phase: N

Power: AC 120V/60Hz

Distance:

Temperature: 26 °C

Humidity: 58 %

Air Pressure: hpa

No.	Mk.	Freq. MHz	Reading Level dBuV	Factor dB	Measure- ment dBuV	Limit dBuV	Over dB	Detector	Comment
1	*	0.3450	47.40	0.10	47.50	59.08	-11.58	QP	
2		0.3450	36.90	0.10	37.00	49.08	-12.08	AVG	
3		0.6950	39.80	0.04	39.84	56.00	-16.16	QP	
4		0.6950	26.10	0.04	26.14	46.00	-19.86	AVG	
5		0.9200	42.90	0.03	42.93	56.00	-13.07	QP	
6		0.9200	30.40	0.03	30.43	46.00	-15.57	AVG	
7		1.5800	41.20	0.03	41.23	56.00	-14.77	QP	
8		1.5800	22.10	0.03	22.13	46.00	-23.87	AVG	
9		1.7750	42.30	0.03	42.33	56.00	-13.67	QP	
10		1.7750	23.60	0.03	23.63	46.00	-22.37	AVG	
11		2.7650	39.70	0.03	39.73	56.00	-16.27	QP	
12		2.7650	22.40	0.03	22.43	46.00	-23.57	AVG	

Unless otherwise stated the results shown in this test report refer only to the sample(s) tested. This test report cannot be reproduced, except in full, without prior written permission of the Company. 除非另有說明，此報告結果僅對測試之樣品負責。本報告未經本公司書面許可，不可部份複製。

This Test Report is issued by the Company under its General Conditions of Service which is available on request or accessible at [http://www.sgs.com/terms\\_and\\_conditions.htm](http://www.sgs.com/terms_and_conditions.htm). Attention is drawn to the limitation of liability, indemnification and jurisdiction issues defined therein. Any holder of this Test Report is advised that information contained hereon reflects the Company's findings at the time of its intervention only and within the limits of Client's instructions, if any. The Company's sole responsibility is to its Client and this document does not exonerate parties to a transaction from exercising all their rights and obligations under the transaction documents. Any unauthorized alteration, forgery or falsification of the content or appearance of this document is unlawful and offenders may be prosecuted to the fullest extent of the law.

### AC POWER LINE CONDUCTED EMISSION TEST DATA

Operation Mode:	GSM 1900 LINK		Test Date:	May.14,2008	
Temperature:	25 °C	Humidity:	62%	Test By:	Duka
Adaptor:	T5002684AGAB				

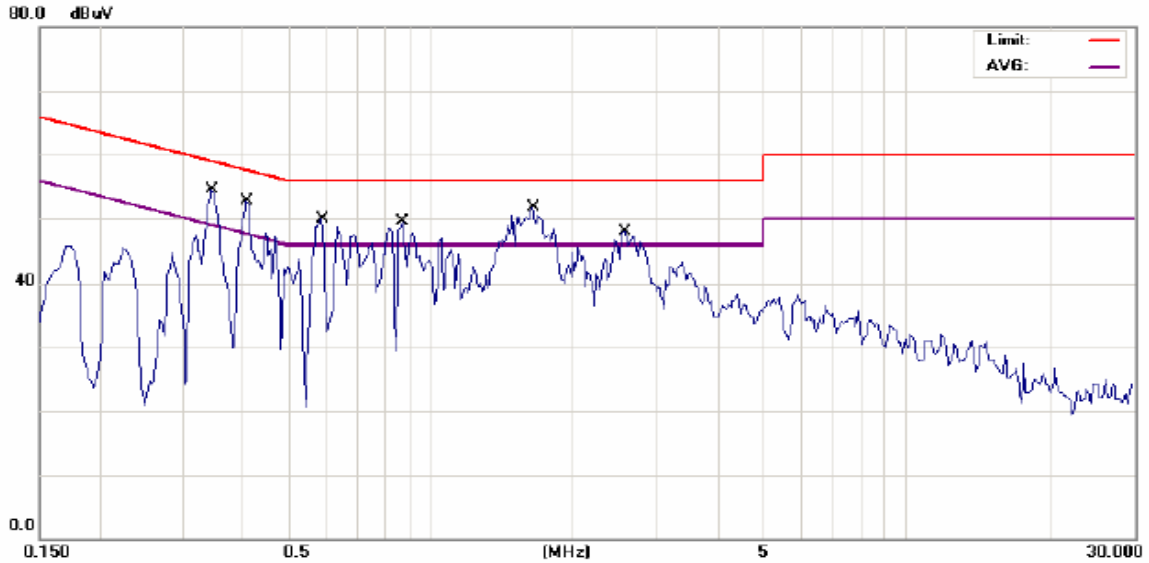

Site SGS CONDUCTED #1	Phase: L1	Temperature: 26 °C
Limit: CISPR22/11 Class B Conduction(QP)	Power: AC 120V/60Hz	Humidity: 58 %
EUT: Mobile Phone	Distance:	Air Pressure: hpa
M/N: OT-S210A		
Note: GSM 1900 LINK		

No.	Mk.	Freq.	Reading Level	Factor	Measurement	Limit	Over	Detector	Comment
		MHz	dBuV	dB	dBuV	dBuV	dB		
1		0.3450	51.90	0.11	52.01	59.08	-7.07	QP	
2		0.3450	42.30	0.11	42.41	49.08	-6.67	AVG	
3		0.4100	50.70	0.09	50.79	57.65	-6.86	QP	
4		0.4100	37.60	0.09	37.69	47.65	-9.96	AVG	
5	*	0.5900	49.40	0.06	49.46	56.00	-6.54	QP	
6		0.5900	34.50	0.06	34.56	46.00	-11.44	AVG	
7		0.8750	48.70	0.04	48.74	56.00	-7.26	QP	
8		0.8750	32.60	0.04	32.64	46.00	-13.36	AVG	
9		1.6400	48.60	0.04	48.64	56.00	-7.36	QP	
10		1.6400	31.40	0.04	31.44	46.00	-14.56	AVG	
11		2.5700	44.80	0.04	44.84	56.00	-11.16	QP	
12		2.5700	29.40	0.04	29.44	46.00	-16.56	AVG	

Unless otherwise stated the results shown in this test report refer only to the sample(s) tested. This test report cannot be reproduced, except in full, without prior written permission of the Company. 除非另有說明，此報告結果僅對測試之樣品負責。本報告未經本公司書面許可，不可部份複製。

This Test Report is issued by the Company under its General Conditions of Service which is available on request or accessible at [http://www.sgs.com/terms\\_and\\_conditions.htm](http://www.sgs.com/terms_and_conditions.htm). Attention is drawn to the limitation of liability, indemnification and jurisdiction issues defined therein. Any holder of this Test Report is advised that information contained hereon reflects the Company's findings at the time of its intervention only and within the limits of Client's instructions, if any. The Company's sole responsibility is to its Client and this document does not exonerate parties to a transaction from exercising all their rights and obligations under the transaction documents. Any unauthorized alteration, forgery or falsification of the content or appearance of this document is unlawful and offenders may be prosecuted to the fullest extent of the law.

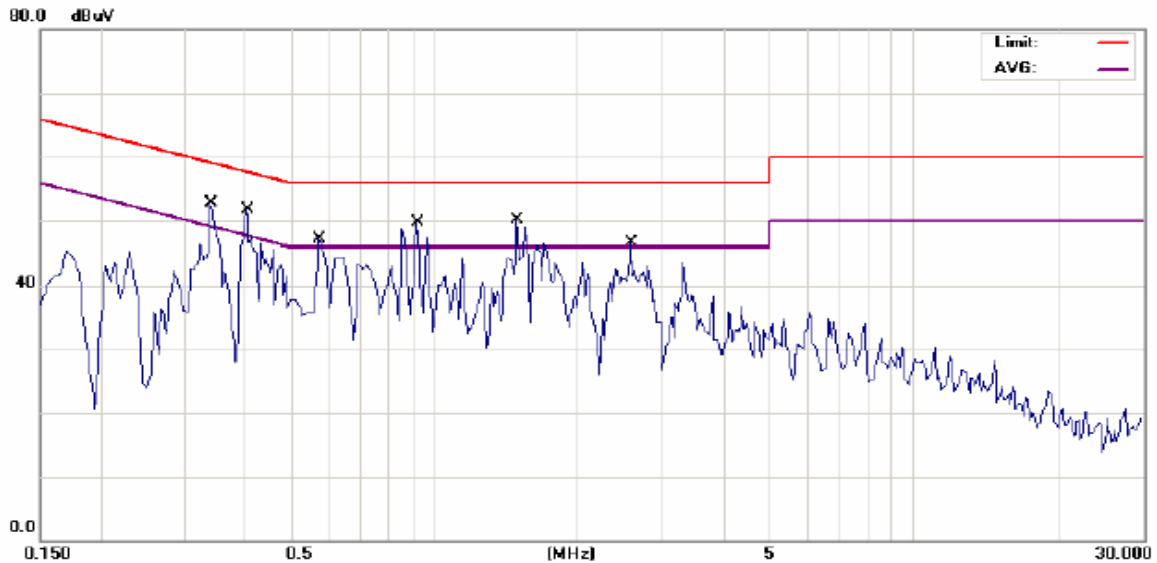

Site SGS CONDUCTED #1

Limit: CISPR22/11 Class B Conduction(QP)

EUT: Mobile Phone

M/N: OT-S210A

Note: GSM 1900 LINK

Phase: **N**

Power: AC 120V/60Hz

Distance:

Temperature: 26 °C

Humidity: 58 %

Air Pressure: hpa

No.	Mk.	Freq. MHz	Reading Level dBuV	Factor dB	Measure- ment dBuV	Limit dBuV	Over dB	Detector	Comment
1		0.3400	47.70	0.10	47.80	59.20	-11.40	QP	
2		0.3400	37.00	0.10	37.10	49.20	-12.10	AVG	
3		0.4050	43.90	0.08	43.98	57.75	-13.77	QP	
4		0.4050	28.50	0.08	28.58	47.75	-19.17	AVG	
5		0.5750	42.40	0.05	42.45	56.00	-13.55	QP	
6		0.5750	31.20	0.05	31.25	46.00	-14.75	AVG	
7		0.9200	43.50	0.03	43.53	56.00	-12.47	QP	
8		0.9200	29.80	0.03	29.83	46.00	-16.17	AVG	
9	*	1.4900	44.70	0.03	44.73	56.00	-11.27	QP	
10		1.4900	28.60	0.03	28.63	46.00	-17.37	AVG	
11		2.5850	41.20	0.03	41.23	56.00	-14.77	QP	
12		2.5850	23.80	0.03	23.83	46.00	-22.17	AVG	

Unless otherwise stated the results shown in this test report refer only to the sample(s) tested. This test report cannot be reproduced, except in full, without prior written permission of the Company. 除非另有說明，此報告結果僅對測試之樣品負責。本報告未經本公司書面許可，不可部份複製。

This Test Report is issued by the Company under its General Conditions of Service which is available on request or accessible at [http://www.sgs.com/terms\\_and\\_conditions.htm](http://www.sgs.com/terms_and_conditions.htm). Attention is drawn to the limitation of liability, indemnification and jurisdiction issues defined therein. Any holder of this Test Report is advised that information contained hereon reflects the Company's findings at the time of its intervention only and within the limits of Client's instructions, if any. The Company's sole responsibility is to its Client and this document does not exonerate parties to a transaction from exercising all their rights and obligations under the transaction documents. Any unauthorized alteration, forgery or falsification of the content or appearance of this document is unlawful and offenders may be prosecuted to the fullest extent of the law.

### AC POWER LINE CONDUCTED EMISSION TEST DATA

Operation Mode:	GSM 850 LINK		Test Date:	May.14,2008	
Temperature:	25 °C	Humidity:	62%	Test By:	Duka
Adaptor:	T5002684AGAA				

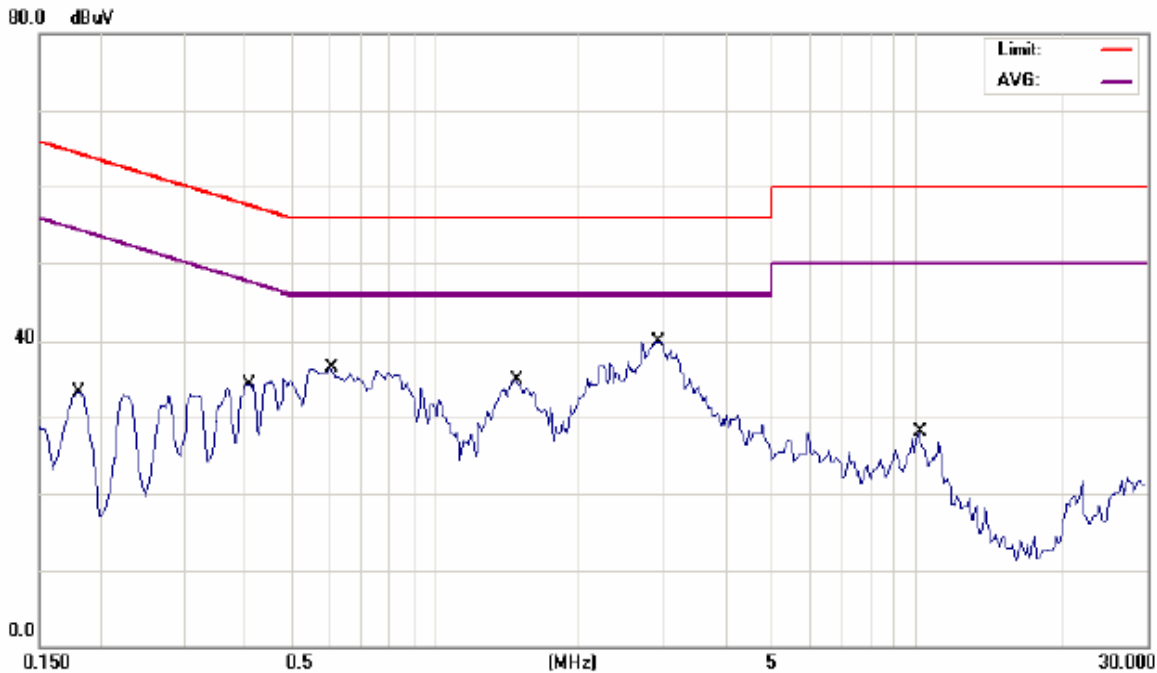

Site	SGS CONDUCTED #1	Phase:	L1	Temperature:	25 °C
Limit:	CISPR22 Class B Conduction(QP)	Power:	AC 120V/60Hz	Humidity:	57 %
EUT:	Mobile Phone	Distance:		Air Pressure:	hpa
M/N:	OT-S210A				
Note:	GSM 850 LINK				

No.	Mk.	Freq. MHz	Reading Level dBuV	Factor dB	Measurement dBuV	Limit dBuV	Over dB	Detector	Comment
1		0.1800	33.09	0.26	33.35	64.49	-31.14	QP	
2		0.4050	34.24	0.09	34.33	57.75	-23.42	QP	
3		0.6050	36.51	0.06	36.57	56.00	-19.43	QP	
4		1.4750	34.85	0.04	34.89	56.00	-21.11	QP	
5	*	2.9300	39.92	0.04	39.96	56.00	-16.04	QP	
6		10.1800	28.00	0.10	28.10	60.00	-31.90	QP	

Unless otherwise stated the results shown in this test report refer only to the sample(s) tested. This test report cannot be reproduced, except in full, without prior written permission of the Company. 除非另有說明，此報告結果僅對測試之樣品負責。本報告未經本公司書面許可，不可部份複製。  
 This Test Report is issued by the Company under its General Conditions of Service which is available on request or accessible at [http://www.sgs.com/terms\\_and\\_conditions.htm](http://www.sgs.com/terms_and_conditions.htm). Attention is drawn to the limitation of liability, indemnification and jurisdiction issues defined therein. Any holder of this Test Report is advised that information contained hereon reflects the Company's findings at the time of its intervention only and within the limits of Client's instructions, if any. The Company's sole responsibility is to its Client and this document does not exonerate parties to a transaction from exercising all their rights and obligations under the transaction documents. Any unauthorized alteration, forgery or falsification of the content or appearance of this document is unlawful and offenders may be prosecuted to the fullest extent of the law.

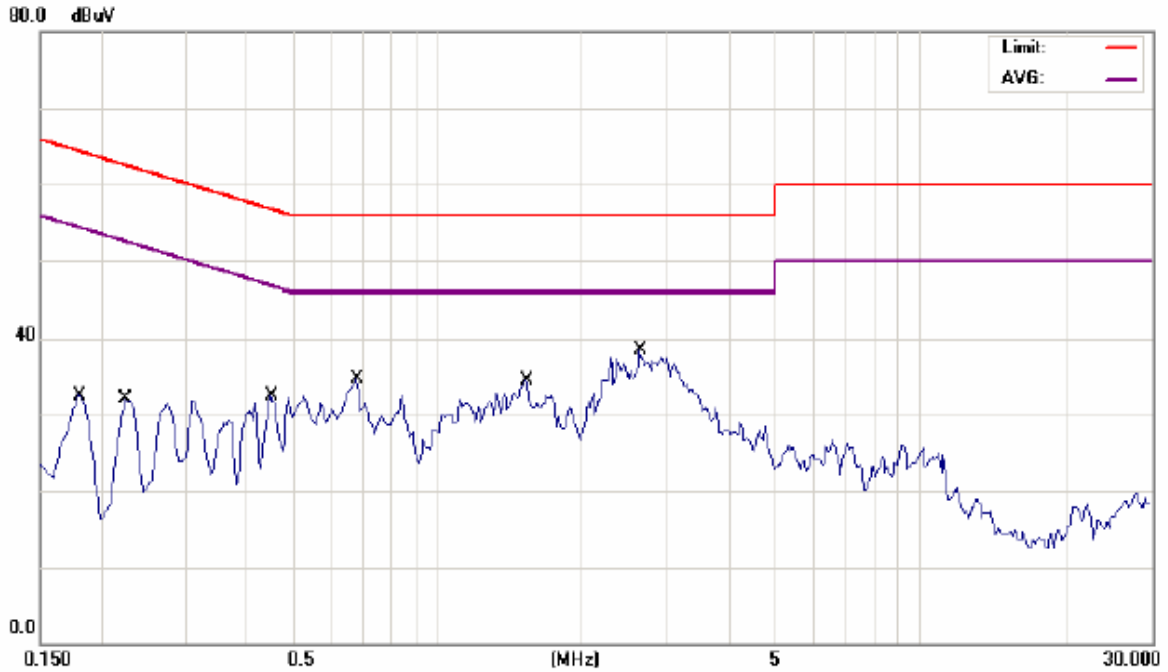

Site SGS CONDUCTED #1  
 Limit: CISPR22 Class B Conduction(QP)  
 EUT: Mobile Phone  
 M/N: OT-S210A  
 Note: GSM 850 LINK

Phase: **N**  
 Power: AC 120V/60Hz  
 Distance:

Temperature: 25 °C  
 Humidity: 57 %  
 Air Pressure: hpa

No.	Mk.	Freq. MHz	Reading Level dBuV	Factor dB	Measure- ment dBuV	Limit dBuV	Over dB	Detector	Comment
1		0.1800	32.36	0.24	32.60	64.49	-31.89	QP	
2		0.2250	31.90	0.13	32.03	62.63	-30.60	QP	
3		0.4500	32.34	0.07	32.41	56.88	-24.47	QP	
4		0.6800	34.59	0.04	34.63	56.00	-21.37	QP	
5		1.5350	34.40	0.03	34.43	56.00	-21.57	QP	
6	*	2.6450	38.41	0.03	38.44	56.00	-17.56	QP	

Unless otherwise stated the results shown in this test report refer only to the sample(s) tested. This test report cannot be reproduced, except in full, without prior written permission of the Company. 除非另有說明，此報告結果僅對測試之樣品負責。本報告未經本公司書面許可，不可部份複製。  
 This Test Report is issued by the Company under its General Conditions of Service which is available on request or accessible at [http://www.sgs.com/terms\\_and\\_conditions.htm](http://www.sgs.com/terms_and_conditions.htm). Attention is drawn to the limitation of liability, indemnification and jurisdiction issues defined therein. Any holder of this Test Report is advised that information contained hereon reflects the Company's findings at the time of its intervention only and within the limits of Client's instructions, if any. The Company's sole responsibility is to its Client and this document does not exonerate parties to a transaction from exercising all their rights and obligations under the transaction documents. Any unauthorized alteration, forgery or falsification of the content or appearance of this document is unlawful and offenders may be prosecuted to the fullest extent of the law.



### AC POWER LINE CONDUCTED EMISSION TEST DATA

Operation Mode:	GSM 1900 LINK		Test Date:	May.14,2008	
Temperature:	25 °C	Humidity:	62%	Test By:	Duka
Adaptor:	T5002684AGAA				



Site SGS CONDUCTED #1	Phase: <b>L1</b>	Temperature: 25 °C
Limit: CISPR22 Class B Conduction(QP)	Power: AC 120V/60Hz	Humidity: 57 %
EUT: Mobile Phone	Distance:	Air Pressure: hpa
M/N: OT-S210A		
Note: GSM 1900 LINK		

No.	Mk.	Freq. MHz	Reading Level dBuV	Factor dB	Measure- ment dBuV	Limit dBuV	Over dB	Detector	Comment
1		0.1800	33.01	0.26	33.27	64.49	-31.22	QP	
2		0.4100	34.44	0.09	34.53	57.65	-23.12	QP	
3		0.6200	36.95	0.06	37.01	56.00	-18.99	QP	
4		1.5350	35.43	0.04	35.47	56.00	-20.53	QP	
5	*	2.8100	40.52	0.04	40.56	56.00	-15.44	QP	
6		10.2000	27.74	0.10	27.84	60.00	-32.16	QP	

Unless otherwise stated the results shown in this test report refer only to the sample(s) tested. This test report cannot be reproduced, except in full, without prior written permission of the Company. 除非另有說明，此報告結果僅對測試之樣品負責。本報告未經本公司書面許可，不可部份複製。  
 This Test Report is issued by the Company under its General Conditions of Service which is available on request or accessible at [http://www.sgs.com/terms\\_and\\_conditions.htm](http://www.sgs.com/terms_and_conditions.htm). Attention is drawn to the limitation of liability, indemnification and jurisdiction issues defined therein. Any holder of this Test Report is advised that information contained hereon reflects the Company's findings at the time of its intervention only and within the limits of Client's instructions, if any. The Company's sole responsibility is to its Client and this document does not exonerate parties to a transaction from exercising all their rights and obligations under the transaction documents. Any unauthorized alteration, forgery or falsification of the content or appearance of this document is unlawful and offenders may be prosecuted to the fullest extent of the law.

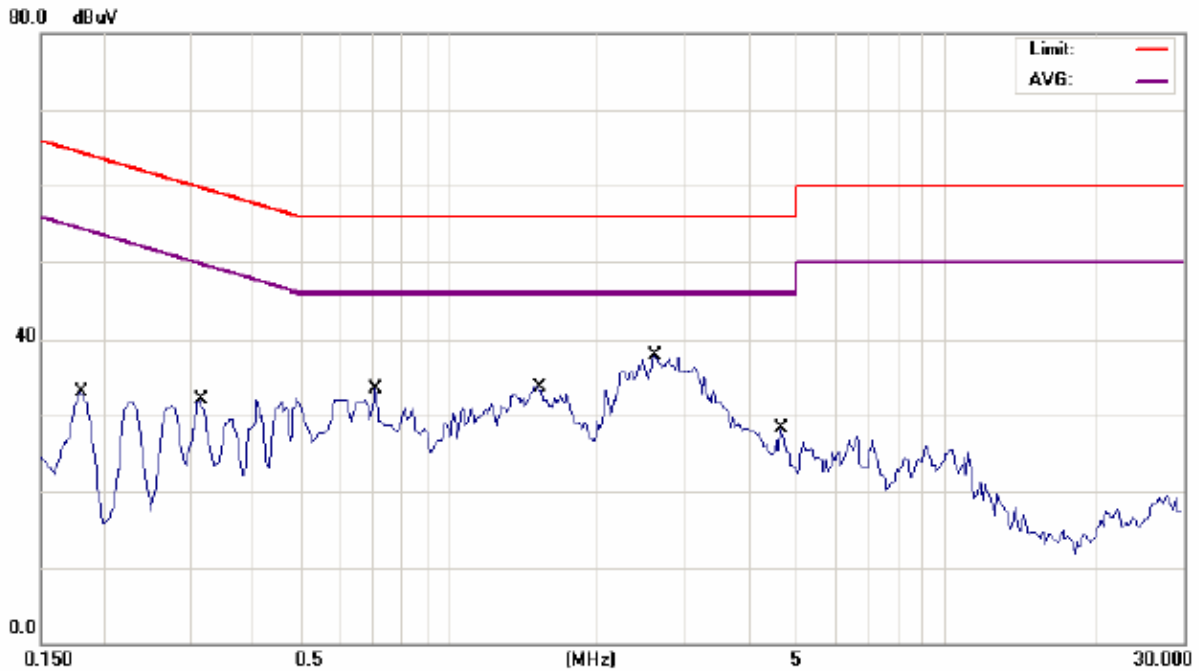

Site SGS CONDUCTED #1

Phase: **N**

Temperature: 25 °C

Limit: CISPR22 Class B Conduction(QP)

Power: AC 120V/60Hz

Humidity: 57 %

EUT: Mobile Phone

Distance:

Air Pressure: hpa

M/N: OT-S210A

Note: GSM 1900 LINK

No.	Mk.	Freq. MHz	Reading Level dBuV	Factor dB	Measure- ment dBuV	Limit dBuV	Over dB	Detector	Comment
1		0.1800	32.85	0.24	33.09	64.49	-31.40	QP	
2		0.3150	31.94	0.11	32.05	59.84	-27.79	QP	
3		0.7100	33.40	0.04	33.44	56.00	-22.56	QP	
4		1.5200	33.66	0.03	33.69	56.00	-22.31	QP	
5	*	2.6000	37.85	0.03	37.88	56.00	-18.12	QP	
6		4.6400	28.19	0.05	28.24	56.00	-27.76	QP	

Unless otherwise stated the results shown in this test report refer only to the sample(s) tested. This test report cannot be reproduced, except in full, without prior written permission of the Company. 除非另有說明，此報告結果僅對測試之樣品負責。本報告未經本公司書面許可，不可部份複製。

This Test Report is issued by the Company under its General Conditions of Service which is available on request or accessible at [http://www.sgs.com/terms\\_and\\_conditions.htm](http://www.sgs.com/terms_and_conditions.htm). Attention is drawn to the limitation of liability, indemnification and jurisdiction issues defined therein. Any holder of this Test Report is advised that information contained hereon reflects the Company's findings at the time of its intervention only and within the limits of Client's instructions, if any. The Company's sole responsibility is to its Client and this document does not exonerate parties to a transaction from exercising all their rights and obligations under the transaction documents. Any unauthorized alteration, forgery or falsification of the content or appearance of this document is unlawful and offenders may be prosecuted to the fullest extent of the law.