

SAR TEST REPORT

Equipment Under Test :	GSM 850&PCS 1900MHz MOBILE PHONES
Model No. :	U81A
Market name:	OT-S120A
FCC ID:	RAD076
Applicant :	TCT Mobile Suzhou Limited
Address of Applicant :	3/F,B2 Block, Digital Technology Yard, Gaoxin Nan Qi Road,Nan Shan District, Shenzhen, Guangdong, P.R. China
Date of Receipt :	2008.04.02
Date of Test :	2008.04.07 ~2008.04.17 2008.07.24~2008.07.25
Date of Issue :	2008.07.25

Standards:

**FCC OET Bulletin 65 supplement C,
ANSI/IEEE C95.1, C95.3, IEEE 1528-2003**

In the configuration tested, the EUT complied with the standards specified above.

Remarks:

This report details the results of the testing carried out on one sample, the results contained in this test report do not relate to other samples of the same product. The manufacturer should ensure that all products in series production are in conformity with the product sample detailed in this report.

This report may only be reproduced and distributed in full. If the product in this report is used in any configuration other than that detailed in the report, the manufacturer must ensure the new system complies with all relevant standards. Any mention of SGS-CSTC Shanghai GSM Lab or testing done by SGS-CSTC Shanghai GSM Lab must approve SGS Shanghai GSM Lab in connection with distribution or use of the product described in this report in writing.

Tested by :

Zengyong Zhang

Date :

2008.07.25

Approved by :

Zhiang Yuan

Date :

2008.07.25

Contents

1. General Information	5
1.1 Test Laboratory.....	5
1.2 Details of Applicant	5
1.3 Description of EUT(s).....	5
1.4 Test Environment	6
1.5 Operation Configuration	6
1.6 The SAR Measurement System.....	6
1.7 SAR System Verification.....	8
1.8 Tissue Simulant Fluid for the Frequency Band 850MHZ and 1900MHz	9
1.9 Test Standards and Limits	10
2. Summary of Results	11
3. Instruments List	14
4. Measurements	15
4.1 GSM850-LeftHandSide-Cheek-Middle-BYD	15
GSM850-LeftHandSide-Cheek-Middle-BYD.....	15
4.2 GSM850-LeftHandSide-Tilt-Middle-BYD	16
GSM850-LeftHandSide-Tilt-Middle-BYD	16
4.3 GSM850-LeftHandSide-Cheek-Low-BYD	18
GSM850-LeftHandSide-Cheek-Low-BYD.....	18
4.4 GSM850-LeftHandSide-Cheek-High-BYD	20
GSM850-LeftHandSide-Cheek-High-BYD	20
4.5 GSM850-LeftHandSide-Cheek-Low-Coslight	22
GSM850-LeftHandSide-Cheek-Low-Coslight.....	22
4.6 GSM850-RightHandSide-Cheek-Middle-BYD	24
GSM850-RightHandSide-Cheek-Middle-BYD	24
4.7 GSM850-RightHandSide-Tilt-Middle-BYD.....	26
GSM850-RightHandSide-Tilt-Middle-BYD	26
4.8 GSM850-RightHandSide-Cheek-Low-BYD.....	28
GSM850-RightHandSide-Cheek-Low-BYD	28
4.9 GSM850-RightHandSide-Cheek-High-BYD.....	30
GSM850-RightHandSide-Cheek-High-BYD.....	30
4.10 GSM850-RightHandSide-Cheek-Low-Coslight.....	32
GSM850-RightHandSide-Cheek-Low-Coslight.....	32

4.11 GSM850-Body-Worn -Low-BYD-Headset CCA3010000E0	34
GSM850-Body-Worn-Low-2.0cm-BYD- Headset CCA3010000E0	34
4.12 GSM850-Body-Worn -Middle-BYD-Headset CCA3010000E0	36
GSM850-Body-Worn-Middle-2.0cm-BYD-Headset CCA3010000E0	36
4.13 GSM850-Body-Worn -High-BYD-Headset CCA3010000E0	38
GSM850-Body-Worn-High-2.0cm-BYD-Headset CCA3010000E0.....	38
4.14 GSM850-Body-Worn -Low-Coslight-Headset CCA3010000E0	40
GSM850-Body-Worn-Low-2.0cm-Coslight-Headset CCA3010000E0	40
4.15 PCS1900-LeftHandSide-Cheek-Middle-BYD	42
PCS1900-LeftHandSide-Cheek-Middle-BYD	42
4.16 PCS1900-LeftHandSide-Tilt-Middle-BYD	44
PCS1900-LeftHandSide-Tilt-Middle-BYD.....	44
4.17 PCS1900-LeftHandSide-Cheek-Low-BYD	46
PCS1900-LeftHandSide-Cheek-Low-BYD	46
4.18 PCS1900-LeftHandSide-Cheek-High-BYD	48
PCS1900-LeftHandSide-Cheek-High-BYD.....	48
4.19 PCS1900-LeftHandSide-Cheek-Middle-Coslight	50
PCS1900-LeftHandSide-Cheek-Middle-Coslight	50
4.20 PCS1900-RightHandSide-Cheek-Middle-BYD	52
PCS1900-RightHandSide-Cheek-Middle-BYD	52
4.21 PCS1900-RightHandSide-Tilt-Middle-BYD	54
PCS1900-RightHandSide-Tilt-Middle-BYD	54
4.22 PCS1900-RightHandSide-Cheek-Low-BYD	56
PCS1900-RightHandSide-Cheek-Low-BYD	56
4.23 PCS1900-RightHandSide-Cheek-High-BYD	58
PCS1900-RightHandSide-Cheek-High-BYD	58
4.24 PCS1900-RightHandSide-Cheek-Middle-Coslight	60
PCS1900-RightHandSide-Cheek-Middle-Coslight	60
4.25 PCS1900-Body-Worn -Low-BYD-Headset CCA3010000E0	62
PCS1900-Body-Worn-Low-2.0cm-BYD-Headset CCA3010000E0.....	62
4.26 PCS1900-Body-Worn -Middle-BYD-Headset CCA3010000E0	64
PCS1900-Body-Worn-Middle-2.0cm-BYD-Headset CCA3010000E0.....	64
4.27 PCS1900-Body-Worn -High-BYD-Headset CCA3010000E0	66
PCS1900-Body-Worn-High-2.0cm-BYD-Headset CCA3010000E0	66
4.28 PCS1900-Body-Worn -Low-Coslight-Headset CCA3010000E0	68

PCS1900-Body-Worn-Low-2.0cm-Colisght-Headset CCA3010000E0.....	68
4.29 GSM850-Flat Phantom- Head-Middle-BYD	70
GSM850-Head-Worn-Mid-BYD-0.5cm	70
4.30 GSM850-Flat Phantom- Head-Low-BYD.....	72
GSM850-Head-Worn-Low-BYD-0.5cm.....	72
4.31 GSM850-Flat Phantom- Head-High-BYD.....	74
GSM850-Head-Worn-High-BYD-0.5cm.....	74
4.32 GSM850-Flat Phantom- Head-High-Coslight.....	75
GSM850-Head-Worn-High-Cos-0.5cm	75
4.33 PCS1900-Flat Phantom- Head-Middle-BYD	77
PCS1900-Head-Worn-Mid-BYD-0.5cm.....	77
4.34 PCS1900-Flat Phantom- Head-Low-BYD	78
PCS1900-Head-Worn-Low-BYD-0.5cm	78
4.35 PCS1900-Flat Phantom- Head-High-BYD.....	80
PCS1900-Head-Worn-High-BYD-0.5cm.....	80
4.36 PCS1900-Flat Phantom- Head-Low-Coslight.....	81
PCS1900-Head-Worn-Low-Cos-0.5cm	81
Appendix	83
1. Photographs of Test Setup.....	83
2. Photographs of the EUT	87
3. Photographs of the battery.....	88
4. Photograph of the charger and Headset	89
5. Probe Calibration certificate.....	90
6. DAE Calibration certification.....	99
7. Dipole Calibration certification	105
8. Uncertainty analysis	123
9. Phantom description	124

1. General Information

1.1 Test Laboratory

GSM Lab

SGS-CSTC Standards Technical Services Co., Ltd Shanghai Branch

9F, the 3rd Building, No.889, Yishan Rd, Xuhui District, Shanghai, China

Zip code: 200233

Telephone: +86 (0) 21 6495 1616

Fax: +86 (0) 21 6495 3679

Internet: <http://www.cn.sgs.com>

1.2 Details of Applicant

Name: TCT Mobile Suzhou Limited

Address: 3/F,B2 Block,Digital Technology Yard,
Gaoxin Nan Qi Road,Nan Shan District,
Shenzhen,Guangdong,P.R.China

1.3 Description of EUT(s)

Brand name	ALCATEL	
Model No.	U81A	
Market Name	OT-S120A	
Hardware Version	PIO4	
Software Version	040	
Serial No.	IMEI: 011452000001826	
Battery Type	BYD	CAB2001010C1
	Coslight	CAB2001010C2
Headset Type	CCA3010000E0	
Antenna Type	Inner Antenna	
Operation Mode	GSM850/PCS1900	
Modulation Mode	GMSK	
Frequency range	GSM850	Tx: 824~849 MHz
		Rx: 869~894 MHz
	PCS1900	Tx: 1850~1910 MHz
		Rx: 1930~1990 MHz
Nominated Maximum RF Conducted Power	GSM850: 33.0dBm, PCS1900: 30.0dBm	

1.4 Test Environment

Ambient temperature: 22.0° C

Tissue Simulating Liquid: 22° C

Relative Humidity: 45%~55%

1.5 Operation Configuration

Configuration 1: GSM 850, LeftHandSide Cheek & 15° Tilt Position

Configuration 2: GSM 850, RightHandSide Cheek & 15° Tilt Position

Configuration 3: GSM 850, BodyWorn (2.0cm between EUT and phantom)

Configuration 4: PCS 1900, LeftHandSide Cheek & 15° Tilt Position

Configuration 5: PCS 1900, RightHandSide Cheek & 15° Tilt Position

Configuration 6: PCS 1900, BodyWorn (2.0cm between EUT and phantom)

Configuration 7: GSM 850&1900 Additional tests due to antenna approaching mouth
(0.5cm between EUT Top and Flat phantom)

1.6 The SAR Measurement System

A photograph of the SAR measurement System is given in Fig. a.

This SAR Measurement System uses a Computer-controlled 3-D stepper motor system (Speag Dasy 4 professional system). A Model ES3DV3 3088 E-field probe is used to determine the internal electric fields. The SAR can be obtained from the equation $SAR = \sigma (|E_i|^2) / \rho$ where σ and ρ are the conductivity and mass density of the tissue-simulant.

The DASY4 system for performing compliance tests consists of the following items:

- ÿ A standard high precision 6-axis robot (Stabile RX family) with controller, teach pendant and software. An arm extension for accommodation the data acquisition electronics (DAE).
- ÿ A dosimetric probe, i.e., an isotropic E-field probe optimized and calibrated for usage in tissue simulating liquid. The probe is equipped with an optical surface

detector system.

- ÿ A data acquisition electronics (DAE) which performs the signal amplification, signal multiplexing, AD-conversion, offset measurements, mechanical surface detection, collision detection, etc. The unit is battery powered with standard or rechargeable batteries. The signal is optically transmitted to the EOC.
- ÿ The Electro-optical converter (EOC) performs the conversion between optical and electrical of the signals for the digital communication to DAE and for the analog signal from the optical surface detection. The EOC is connected to the measurement server.

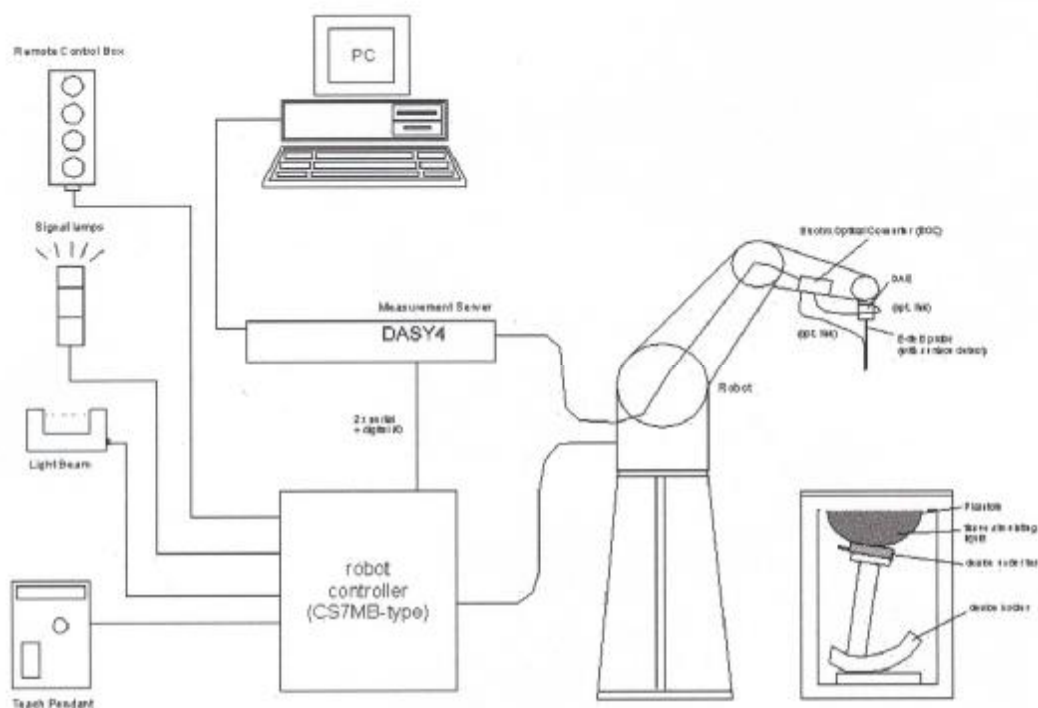

Fig. a SAR System Configuration

- ÿ The function of the measurement server is to perform the time critical tasks such as signal filtering, control of the robot operation and fast movement interrupts.
- ÿ A probe alignment unit which improves the (absolute) accuracy of the probe positioning.
- ÿ A computer operating Windows 2000.
- ÿ DASY4 software.
- ÿ Remote control with teach pendant and additional circuitry for robot safety such as

warning lamps, etc.

- ÿ The SAM twin phantom enabling testing left-hand, right-hand and body-worn usage.
- ÿ The device holder for handheld mobile phones.
- ÿ Tissue simulating liquid mixed according to the given recipes.
- ÿ Validation dipole kits allowing to validating the proper functioning of the system.

1.7 SAR System Verification

The microwave circuit arrangement for system verification is sketched in Fig. b. The daily system accuracy verification occurs within the flat section of the SAM phantom. A SAR measurement was performed to see if the measured SAR was within +/- 10% from the target SAR values. These tests were done at 900&1900MHz. The tests were conducted on the same days as the measurement of the DUT. The obtained results from the system accuracy verification are displayed in the table 1 (SAR values are normalized to 1W forward power delivered to the dipole). During the tests, the ambient temperature of the laboratory was in the range 22°C, the relative humidity was in the range 60% and the liquid depth above the ear reference points was above 15 cm in all the cases. It is seen that the system is operating within its specification, as the results are within acceptable tolerance of the reference values.

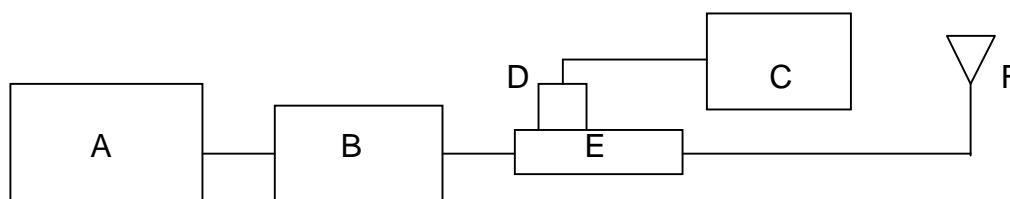

Fig. b the microwave circuit arrangement used for SAR system verification

A. Agilent Model E4438C Signal generator

B. Mini-Circuit Model ZHL-42 Preamplifier

C. Agilent Model E4416A Power Meter

D. Agilent Model 8481H Power Sensor

E. HT CP6100 20N Dual directional coupler

F. Reference dipole antenna

Validation Kit	Frequency MHz	Target SAR 1g (250mW)	Target SAR 10g (250mW)	Measured SAR 1g	Measured SAR 10g	Measured Date
D900V2 SN184	900 Head	2.73	1.75	2.78	1.76	2008-04-07
				2.76	1.74	2008-04-17
				2.67	1.65	2008-07-25
D900V2 SN184	900 Body	2.90	1.87	2.86	1.83	2008-04-15
D1900V2 SN5d028	1900 Head	9.82	5.14	9.27	4.86	2008-04-10
				9.62	4.93	2008-07-24
D1900V2 SN5d028	1900 Body	9.34	4.97	9.47	4.92	2008-04-11

Table 1. Result System Validation

1.8 Tissue Simulant Fluid for the Frequency Band 850MHZ and 1900MHZ

The dielectric properties for this body-simulant fluid were measured by using the HP Model 85070D Dielectric Probe (rates frequency band 200 MHz to 20 GHz) in conjunction with Agilent E5071B Network Analyzer (300 KHz-8500 MHz). The Conductivity (σ) and Permittivity (ρ) are listed in Table 1. For the SAR measurement given in this report. The temperature variation of the Tissue Simulant Fluid was 22°C.

Frequency (MHz)	Tissue Type	Limit/Measured	Permittivity (ρ)	Conductivity (σ)	Simulated Tissue Temp (°C)
850	Head	Recommended Limit	42.0±5%	0.99±5%	20-24
		Measured, 2008-04-07	42.75	0.957	22.2
		Measured, 2008-04-17	42.42	0.953	22.7
		Measured, 2008-07-25	42.31	0.972	22.6
	Body	Recommended Limit	55.0±5%	1.05±5%	20-24
		Measured, 2008-04-15	55.12	1.034	21.9
1900	Head	Recommended Limit	40.0±5%	1.38±5%	20-24

		Measured, 2008-04-10	39.72	1.371	21.6
		Measured, 2008-07-24	39.46	1.403	22.2
	Body	Recommended Limit	53.3±5%	1.52±5%	20-24
		Measured, 2008-04-11	52.74	1.483	22.0

Table 2. Dielectric parameters for the Frequency Band 900&1900MHZ

1.9 Test Standards and Limits

According to FCC 47 CFR §2.1093(d) the limits to be used for evaluation are based generally on criteria published by the American National Standards Institute (ANSI) for localized specific absorption rate (SAR) in Section 4.2 of "IEEE Standard for Safety Levels with Respect to Human Exposure to Radio Frequency Electromagnetic Fields, 3KHz to 300GHz," ANSI/IEEE C95.1-1992, Copyright 1992 by the Institute of Electrical & Electronics Engineers, Inc., New York, New York 10071.

Human Exposure	Uncontrolled Environment General Population
Spatial Peak SAR (Brain)	1.60 mW/g (averaged over a mass of 1g)

Table 3. RF Exposure Limits

2. Summary of Results

GSM850 SAR

Mode	Test Configuration		SAR, Averaged over 1g (W/kg)			Temperature (°C)	Verdict
	Channel/Power(dBm)		Low/31.4	Middle/31.4	High/31.4		
GSM850	Left	Cheek(BYD)	1.18	1.04	0.922	22	Pass
		Tilt(BYD)	-	0.429	-	22	Pass
		Cheek(Coslight)	1.22	-	-	22	Pass
	Right	Cheek(BYD)	1.21	1.1	0.929	22	Pass
		Tilt(BYD)	-	0.505	-	22	Pass
		Cheek(Coslight)	1.26	-	-	22	Pass
	Body	BYD	0.738	0.615	0.547	22	Pass
		Coslight	0.700	-	-	22	Pass

PCS1900 SAR

Mode	Test Configuration		SAR, Averaged over 1g (W/kg)			Temperature (°C)	Verdict
	Channel/Power(dBm)		Low/29.2	Middle/29.1	High/29.4		
PCS1900	Left	Cheek(BYD)	0.781	0.788	0.711	22	Pass
		Tilt(BYD)	-	0.170	-	22	Pass
		Cheek(Coslight)	-	0.837	-	22	Pass
	Right	Cheek(BYD)	1.18	1.19	1	22	Pass
		Tilt(BYD)	-	0.217	-	22	Pass
		Cheek(Coslight)	-	1.26	-	22	Pass
	Body	BYD	0.532	0.453	0.393	22	Pass
		Coslight	0.491	-	-	22	Pass

Additional Tests to Verify Antenna Approaching Mouth

Mode	Test Configuration		SAR, Averaged over 1g (W/kg)			Temperature (°C)	Verdict
			Low/31.7	Middle/32.0	High/32.1		
GSM850	Channel/Power(dBm)		Low/31.7	Middle/32.0	High/32.1	22	Pass
	Flat Phantom	BYD	0.508	0.605	0.822	22	Pass
	GSM850 Head HSL	Coslight	--	--	0.833	22	Pass
PCS1900	Channel/Power(dBm)		Low/29.6	Middle/29.4	High/29.3	22	Pass
	Flat Phantom	BYD	0.445	0.374	0.339	22	Pass
	GSM1900	Coslight	0.459	--	--	22	Pass
	Head HSL						

Maximum values

Frequency Band (MHz)	EUT position	Conducted Output Power (dBm)	1g Average (W/kg)	Power Drift(dB)	Amb. Temp (°C)	Verdict
850	LeftHand, Cheek, Low Channel , Coslight Battery	31.7	1.22	-0.052	22	PASS
	RightHand, Cheek, Low Channel, Coslight Battery	31.7	1.26	-0.169	22	PASS
	BodyWorn, Low Channel, BYD Battery	31.7	0.738	-0.023	22	PASS
1900	LeftHand, Cheek, Middle Channel, Coslight Battery	29.4	0.837	-0.126	22	PASS
	RightHand, Cheek, Middle Channel, Coslight Battery	29.4	1.26	0.002	22	PASS
	BodyWorn, Low Channel, BYD Battery	29.6	0.532	-0.106	22	PASS

Note:

- In GSM850 band, the low, middle and high channels are CH128/824.2MHz, CH189/836.4MHz and CH251/848.8MHz separately.
- In PCS1900 band, the low, middle and high channels are CH512/1805.2MHz, CH661/1880.0MHz and CH810/1909.8MHz separately.
- For the Bodyworn measurements the sample was only placed with the antenna toward the phantom since this position delivers the highest SAR values. And the distance from the sample to the phantom is 2.0 cm.
- For all the tests, the maximum absolute value of the power drift which is under the GSM850-LeftHandSide-Tilt-Middle-BYD configuration is 0.260dB.

5. Additional tests are performed to verify and eliminate the effect due to antenna approaching mouth. The evidence shows that the effect is restricted since the DUT Physical size is small (97*43*12 Unit: mm).

3. Instruments List

Instrument	Model	Serial number	NO.	Date of last Calibration
Desktop PC	COMPAQ EVO	N/A	GSM-SAR-025	N/A
Dasy 4 software	V 4.7 build 44	N/A	GSM-SAR-001	N/A
Probe	ES3DV3	3088	GSM-SAR-034	2008.1.18
DAE	DAE3	569	GSM-SAR-023	2007.11.19
900MHz system validation dipole	D900V2	184	GSM-SAR-017	2007.12.21
1900MHz system validation dipole	D1900V2	5d028	GSM-SAR-020	2007.12.21
Phantom	SAM 12	TP-1283	GSM-SAR-005	N/A
Robot	RX90L	F03/5V32A1/A01	GSM-SAR-006	N/A
Dielectric probe kit	85070D	US01440168	GSM-SAR-016	2007.12.18
Agilent network analyzer	E5071B	MY42100549	GSM-SAR-007	2007.12.18
Agilent signal generator	E4438	14438CATO-19719	GSM-SAR-008	2007.12.18
Mini-Circuits preamplifier	ZHL-42	D041905	GSM-SAR-033	2007.12.18
Agilent power meter	E4416A	GB41292095	GSM-SAR-010	2007.12.18
Agilent power sensor	8481H	MY41091234	GSM-SAR-011	2007.12.18
HT CP6100 20N Coupling	6100	SCP301480120	GSM-SAR-012	2007.12.18
R&S Universal radio communication tester	CMU200	103633	GSM-AUD-002	2007.12.18

4. Measurements

4.1 GSM850-LeftHandSide-Cheek-Middle-BYD

Date/Time: 2008-4-17 10:07:29

Test Laboratory: SGS-GSM

GSM850-LeftHandSide-Cheek-Middle-BYD

DUT: KJ005AE01; Type: Head; Serial: 011452000001826

Communication System: GSM850-GSM Mode; Frequency: 836.4 MHz; Duty Cycle: 1:8.3

Medium: HSL850-Head Medium parameters used: $f = 836.4$ MHz; $\sigma = 0.905$ mho/m; $\epsilon_r = 42.8$; $\rho = 1000$ kg/m³

Phantom section: Left Section

DASY4 Configuration:

- Probe: ES3DV3 - SN3088; ConvF(6.15, 6.15, 6.15); Calibrated: 2008-1-18
- Sensor-Surface: 4mm (Mechanical Surface Detection)
- Electronics: DAE3 Sn569; Calibrated: 2007-11-19
- Phantom: SAM 12; Type: SAM V4.0; Serial: TP-1283
- Measurement SW: DASY4, V4.7 Build 44; Postprocessing SW: SEMCAD, V1.8 Build 171

Cheek position - Mid BYD/Area Scan (61x91x1): Measurement grid: dx=15mm, dy=15mm

Maximum value of SAR (interpolated) = 1.14 mW/g

Cheek position - Mid BYD/Zoom Scan (7x7x7) (7x7x7)/Cube 0: Measurement grid: dx=5mm, dy=5mm, dz=5mm

Reference Value = 10.9 V/m; Power Drift = -0.034 dB

Peak SAR (extrapolated) = 1.37 W/kg

SAR(1 g) = 1.04 mW/g; SAR(10 g) = 0.720 mW/g

Maximum value of SAR (measured) = 1.11 mW/g

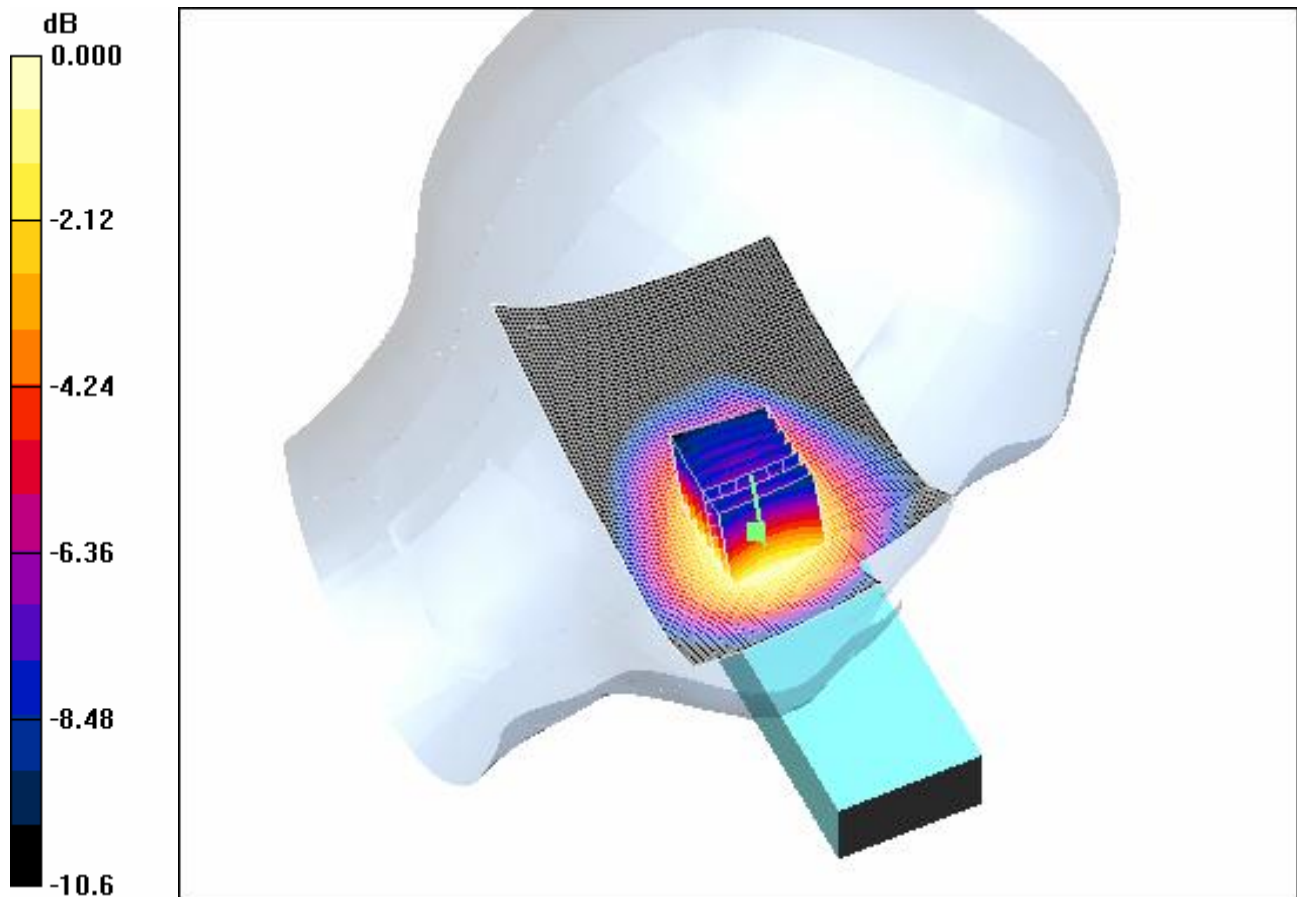

0 dB = 1.11mW/g

4.2 GSM850-LeftHandSide-Tilt-Middle-BYD

Date/Time: 2008-4-17 11:59:40

Test Laboratory: SGS-GSM

GSM850-LeftHandSide-Tilt-Middle-BYD

DUT: KJ005AE01; Type: Head; Serial: 011452000001826

Communication System: GSM850-GSM Mode; Frequency: 836.4 MHz; Duty Cycle: 1:8.3

Medium: HSL850-Head Medium parameters used: $f = 836.4$ MHz; $\sigma = 0.905$ mho/m; $\epsilon_r = 42.8$; $\rho = 1000$ kg/m³

Phantom section: Left Section

DASY4 Configuration:

- Probe: ES3DV3 - SN3088; ConvF(6.15, 6.15, 6.15); Calibrated: 2008-1-18
- Sensor-Surface: 4mm (Mechanical Surface Detection)
- Electronics: DAE3 Sn569; Calibrated: 2007-11-19
- Phantom: SAM 12; Type: SAM V4.0; Serial: TP-1283
- Measurement SW: DASY4, V4.7 Build 44; Postprocessing SW: SEMCAD, V1.8 Build 171

Tilt position - Mid BYD/Area Scan (61x91x1): Measurement grid: dx=15mm, dy=15mm

Maximum value of SAR (interpolated) = 0.453 mW/g

Tilt position - Mid BYD/Zoom Scan (7x7x7) (7x7x7)/Cube 0: Measurement grid: dx=5mm, dy=5mm, dz=5mm

Reference Value = 12.7 V/m; Power Drift = 0.260 dB

Peak SAR (extrapolated) = 0.596 W/kg

SAR(1 g) = 0.429 mW/g; SAR(10 g) = 0.296 mW/g

Maximum value of SAR (measured) = 0.461 mW/g

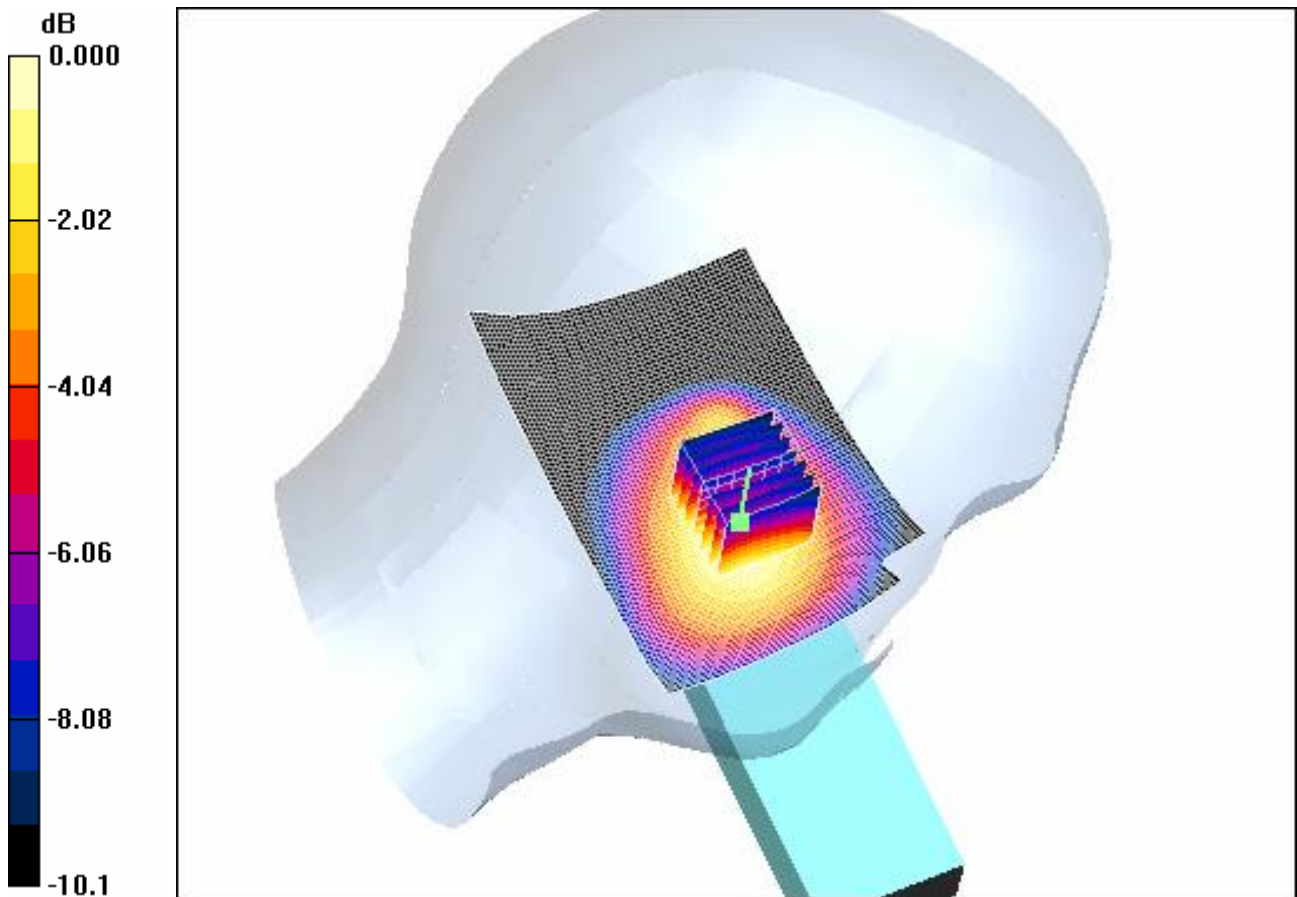

0 dB = 0.461mW/g

4.3 GSM850-LeftHandSide-Cheek-Low-BYD

Date/Time: 2008-4-17 10:41:17

Test Laboratory: SGS-GSM

GSM850-LeftHandSide-Cheek-Low-BYD

DUT: KJ005AE01; Type: Head; Serial: 011452000001826

Communication System: GSM850-GSM Mode; Frequency: 824.2 MHz; Duty Cycle: 1:8.3

Medium: HSL850-Head Medium parameters used: $f = 824.2$ MHz; $\sigma = 0.892$ mho/m; $\epsilon_r = 42.9$; $\rho = 1000$ kg/m³

Phantom section: Left Section

DASY4 Configuration:

- Probe: ES3DV3 - SN3088; ConvF(6.15, 6.15, 6.15); Calibrated: 2008-1-18
- Sensor-Surface: 4mm (Mechanical Surface Detection)
- Electronics: DAE3 Sn569; Calibrated: 2007-11-19
- Phantom: SAM 12; Type: SAM V4.0; Serial: TP-1283
- Measurement SW: DASY4, V4.7 Build 44; Postprocessing SW: SEMCAD, V1.8 Build 171

Cheek position - Low BYD/Area Scan (61x91x1): Measurement grid: dx=15mm, dy=15mm

Maximum value of SAR (interpolated) = 1.29 mW/g

Cheek position - Low BYD/Zoom Scan (7x7x7)/Cube 0: Measurement grid: dx=5mm, dy=5mm, dz=5mm

Reference Value = 12.5 V/m; Power Drift = 0.064 dB

Peak SAR (extrapolated) = 1.57 W/kg

SAR(1 g) = 1.18 mW/g; SAR(10 g) = 0.819 mW/g

Maximum value of SAR (measured) = 1.24 mW/g

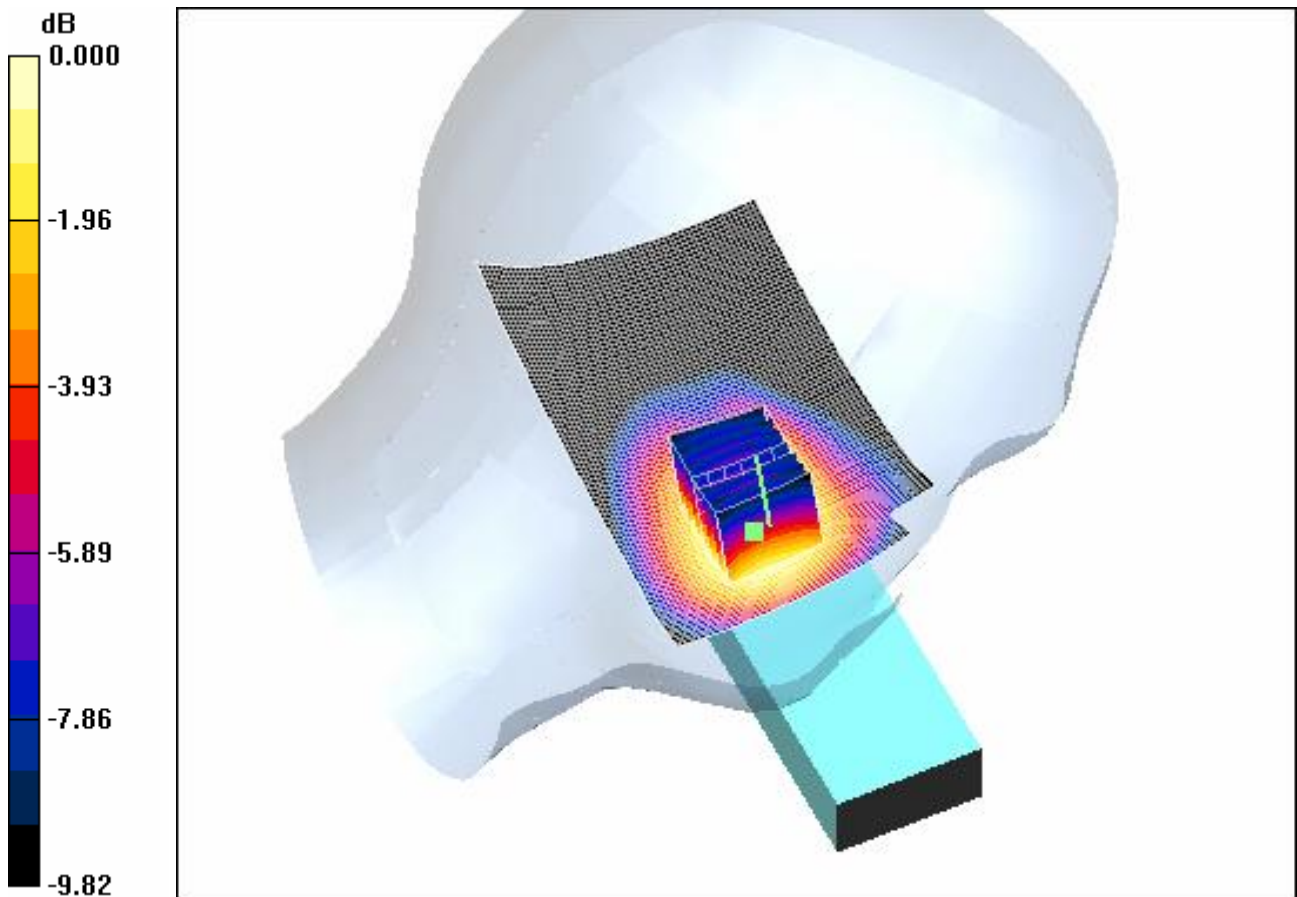

0 dB = 1.24mW/g

4.4 GSM850-LeftHandSide-Cheek-High-BYD

Date/Time: 2008-4-17 11:14:45

Test Laboratory: SGS-GSM

GSM850-LeftHandSide-Cheek-High-BYD

DUT: KJ005AE01; Type: Head; Serial: 011452000001826

Communication System: GSM850-GSM Mode; Frequency: 848.8 MHz; Duty Cycle: 1:8.3

Medium: HSL850-Head Medium parameters used: $f = 848.8$ MHz; $\sigma = 0.918$ mho/m; $\epsilon_r = 42.6$; $\rho = 1000$ kg/m³

Phantom section: Left Section

DASY4 Configuration:

- Probe: ES3DV3 - SN3088; ConvF(6.15, 6.15, 6.15); Calibrated: 2008-1-18
- Sensor-Surface: 4mm (Mechanical Surface Detection)
- Electronics: DAE3 Sn569; Calibrated: 2007-11-19
- Phantom: SAM 12; Type: SAM V4.0; Serial: TP-1283
- Measurement SW: DASY4, V4.7 Build 44; Postprocessing SW: SEMCAD, V1.8 Build 171

Cheek position - High BYD/Area Scan (61x91x1): Measurement grid: dx=15mm, dy=15mm

Maximum value of SAR (interpolated) = 0.991 mW/g

Cheek position - High BYD/Zoom Scan (7x7x7) (7x7x7)/Cube 0: Measurement grid: dx=5mm, dy=5mm, dz=5mm

Reference Value = 10.1 V/m; Power Drift = -0.109 dB

Peak SAR (extrapolated) = 1.23 W/kg

SAR(1 g) = 0.922 mW/g; SAR(10 g) = 0.634 mW/g

Maximum value of SAR (measured) = 0.994 mW/g

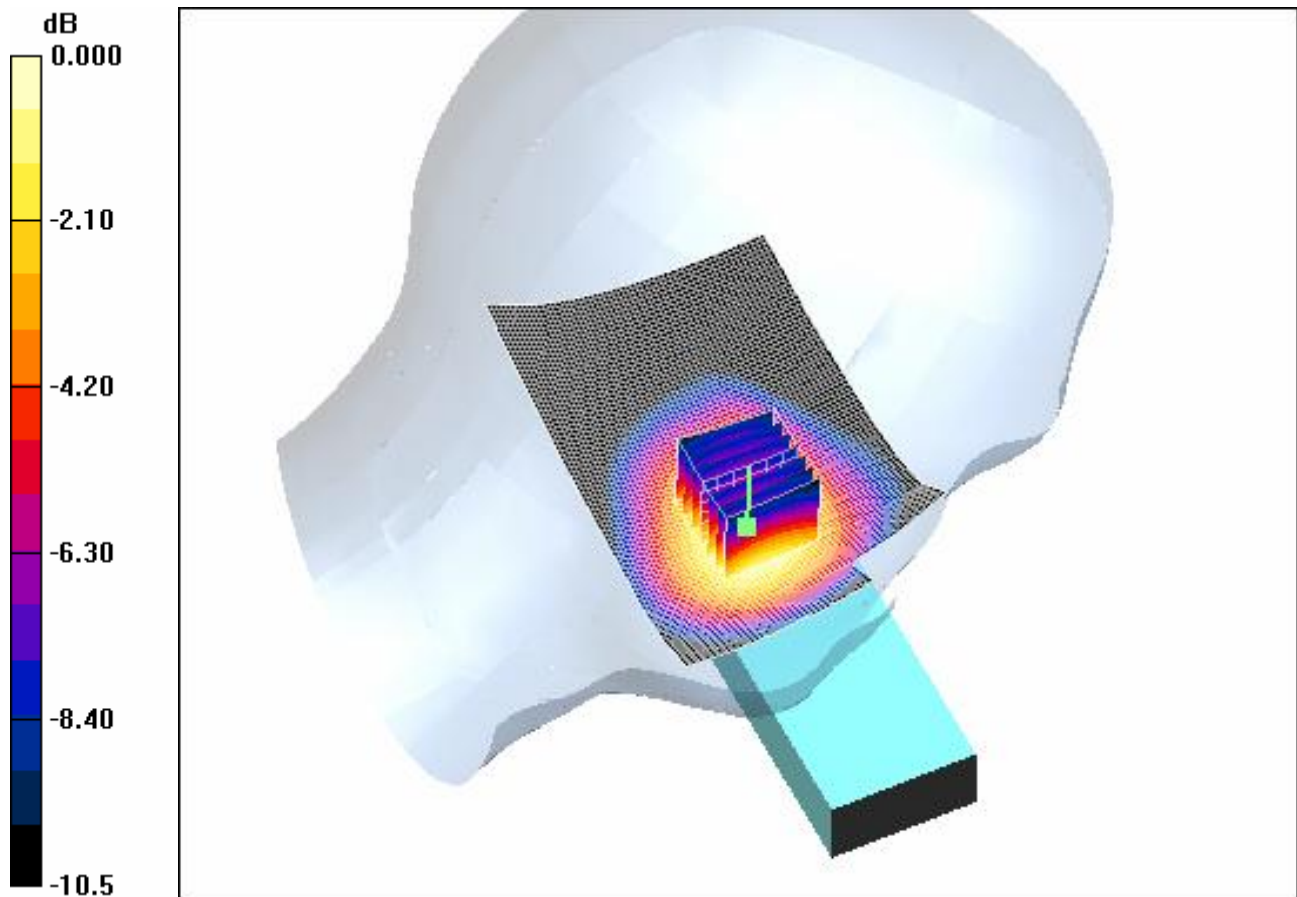

0 dB = 0.994mW/g

4.5 GSM850-LeftHandSide-Cheek-Low-Coslight

Date/Time: 2008-4-17 12:59:13

Test Laboratory: SGS-GSM

GSM850-LeftHandSide-Cheek-Low-Coslight

DUT: KJ005AE01; Type: Head; Serial: 011452000001826

Communication System: GSM850-GSM Mode; Frequency: 824.2 MHz; Duty Cycle: 1:8.3

Medium: HSL850-Head Medium parameters used: $f = 824.2$ MHz; $\sigma = 0.892$ mho/m; $\epsilon_r = 42.9$; $\rho = 1000$ kg/m³

Phantom section: Left Section

DASY4 Configuration:

- Probe: ES3DV3 - SN3088; ConvF(6.15, 6.15, 6.15); Calibrated: 2008-1-18
- Sensor-Surface: 4mm (Mechanical Surface Detection)
- Electronics: DAE3 Sn569; Calibrated: 2007-11-19
- Phantom: SAM 12; Type: SAM V4.0; Serial: TP-1283
- Measurement SW: DASY4, V4.7 Build 44; Postprocessing SW: SEMCAD, V1.8 Build 171

Cheek position - Low Coslight/Area Scan (61x91x1): Measurement grid: dx=15mm, dy=15mm

Maximum value of SAR (interpolated) = 1.32 mW/g

Cheek position - Low Coslight/Zoom Scan (7x7x7) (7x7x7)/Cube 0: Measurement grid: dx=5mm, dy=5mm, dz=5mm

Reference Value = 14.1 V/m; Power Drift = -0.052 dB

Peak SAR (extrapolated) = 1.62 W/kg

SAR(1 g) = 1.22 mW/g; SAR(10 g) = 0.850 mW/g

Maximum value of SAR (measured) = 1.29 mW/g

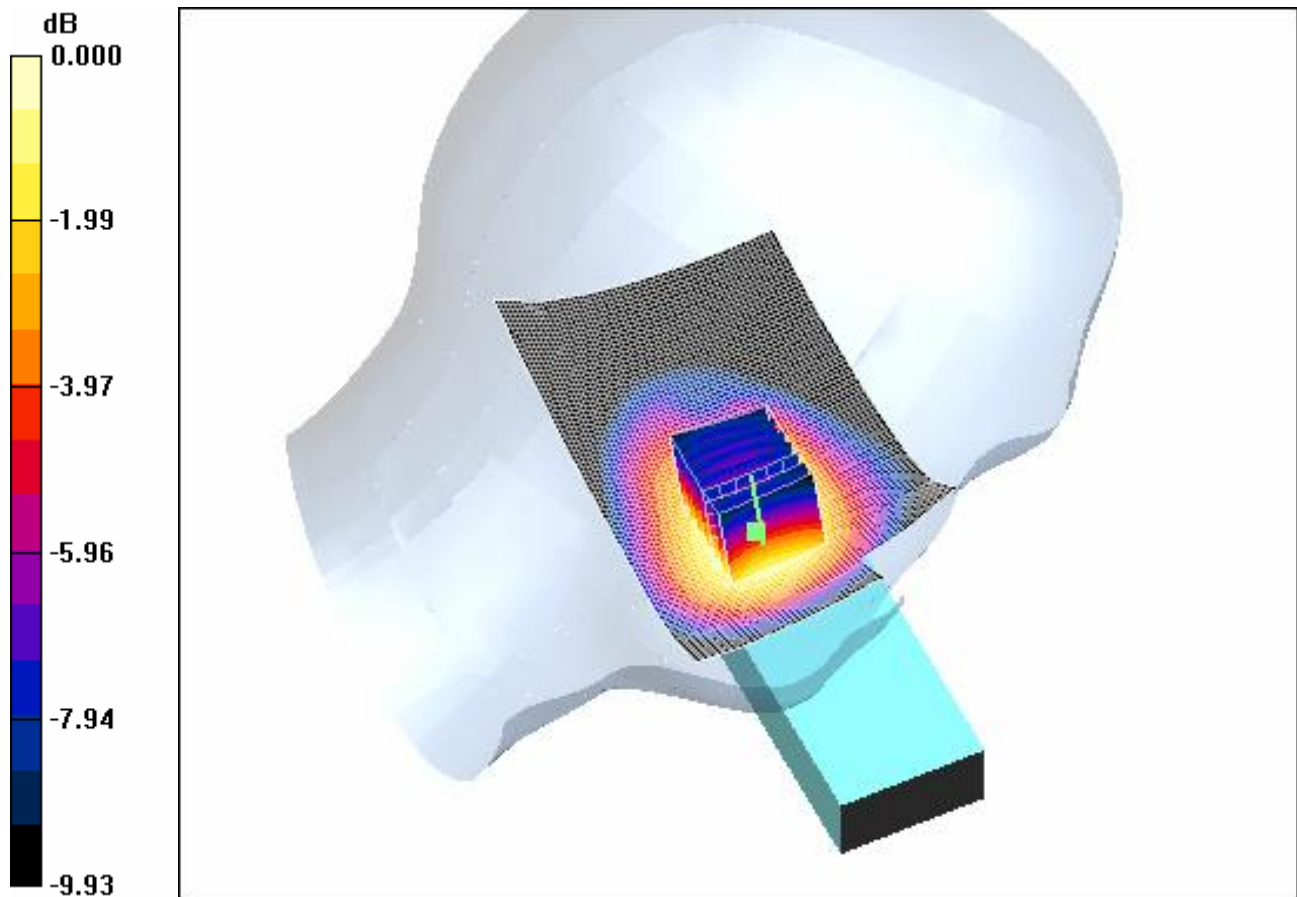

0 dB = 1.29mW/g

4.6 GSM850-RightHandSide-Cheek-Middle-BYD

Date/Time: 2008-4-7 13:37:44

Test Laboratory: SGS-GSM

GSM850-RightHandSide-Cheek-Middle-BYD

DUT: KJ005AE01; Type: Head; Serial: 011452000001826

Communication System: GSM850-GSM Mode; Frequency: 836.4 MHz; Duty Cycle: 1:8.3

Medium: HSL900-Head Medium parameters used: $f = 836.4$ MHz; $\sigma = 0.905$ mho/m; $\epsilon_r = 42.8$; $\rho = 1000$ kg/m³

Phantom section: Right Section

DASY4 Configuration:

- Probe: ES3DV3 - SN3088; ConvF(6.15, 6.15, 6.15); Calibrated: 2008-1-18
- Sensor-Surface: 4mm (Mechanical Surface Detection)
- Electronics: DAE3 Sn569; Calibrated: 2007-11-19
- Phantom: SAM 12; Type: SAM V4.0; Serial: TP-1283
- Measurement SW: DASY4, V4.7 Build 44; Postprocessing SW: SEMCAD, V1.8 Build 171

Cheek position - Middle BYD/Area Scan (61x91x1): Measurement grid: dx=15mm, dy=15mm

Maximum value of SAR (interpolated) = 1.18 mW/g

Cheek position - Middle BYD/Zoom Scan (7x7x7)/Cube 0: Measurement grid: dx=5mm, dy=5mm, dz=5mm

Reference Value = 15.8 V/m; Power Drift = -0.106 dB

Peak SAR (extrapolated) = 1.45 W/kg

SAR(1 g) = 1.1 mW/g; SAR(10 g) = 0.757 mW/g

Maximum value of SAR (measured) = 1.19 mW/g

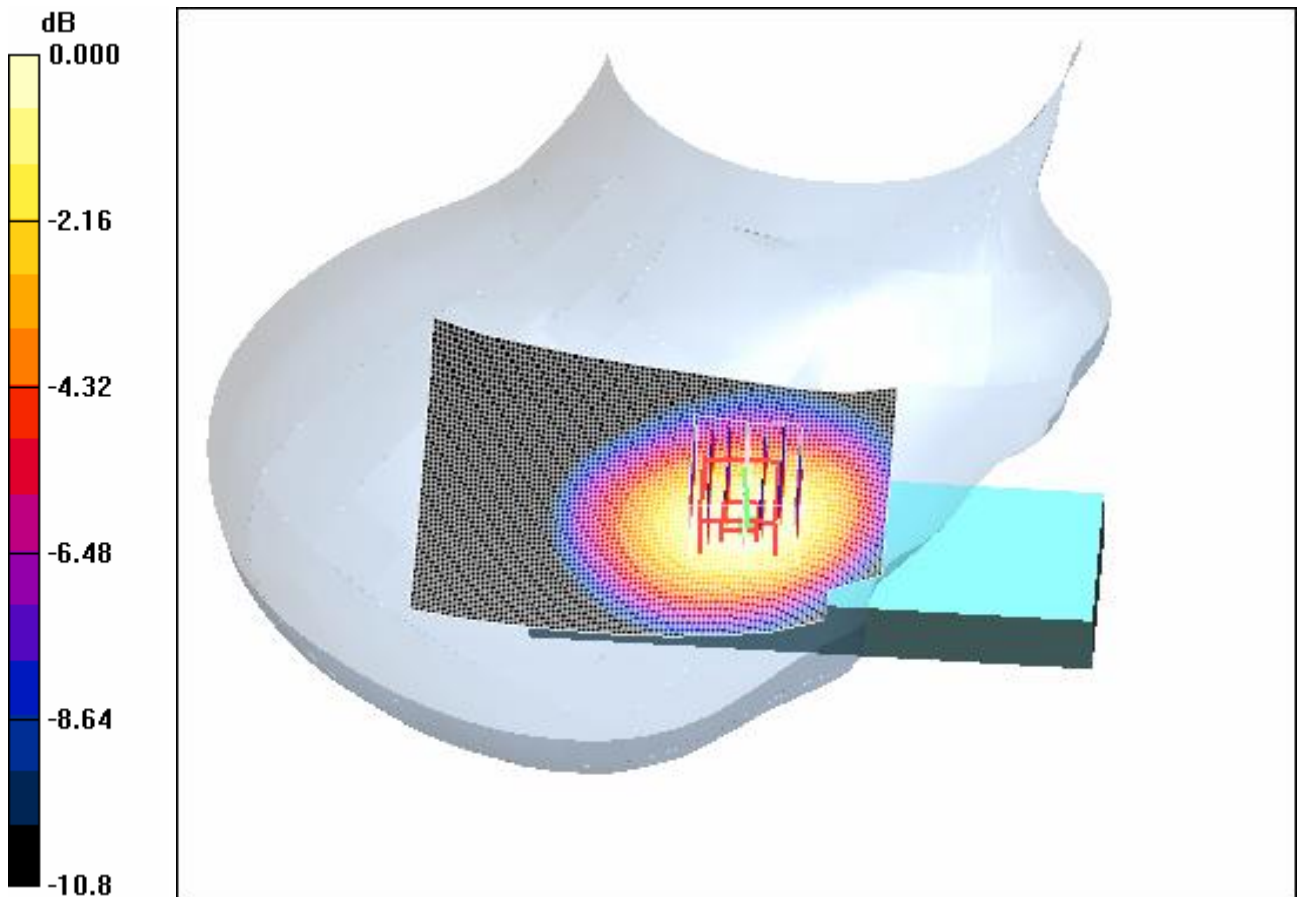

0 dB = 1.19mW/g

4.7 GSM850-RightHandSide-Tilt-Middle-BYD

Date/Time: 2008-4-7 15:17:04

Test Laboratory: SGS-GSM

GSM850-RightHandSide-Tilt-Middle-BYD

DUT: KJ005AE01; Type: Head; Serial: 011452000001826

Communication System: GSM850-GSM Mode; Frequency: 836.4 MHz; Duty Cycle: 1:8.3

Medium: HSL900-Head Medium parameters used: $f = 836.4$ MHz; $\sigma = 0.905$ mho/m; $\epsilon_r = 42.8$; $\rho = 1000$ kg/m³

Phantom section: Right Section

DASY4 Configuration:

- Probe: ES3DV3 - SN3088; ConvF(6.15, 6.15, 6.15); Calibrated: 2008-1-18
- Sensor-Surface: 4mm (Mechanical Surface Detection)
- Electronics: DAE3 Sn569; Calibrated: 2007-11-19
- Phantom: SAM 12; Type: SAM V4.0; Serial: TP-1283
- Measurement SW: DASY4, V4.7 Build 44; Postprocessing SW: SEMCAD, V1.8 Build 171

Tilt position - Middle BYD/Area Scan (61x91x1): Measurement grid: dx=15mm, dy=15mm

Maximum value of SAR (interpolated) = 0.539 mW/g

Tilt position - Middle BYD/Zoom Scan (7x7x7)/Cube 0: Measurement grid: dx=5mm, dy=5mm, dz=5mm

Reference Value = 18.1 V/m; Power Drift = -0.027 dB

Peak SAR (extrapolated) = 0.702 W/kg

SAR(1 g) = 0.505 mW/g; SAR(10 g) = 0.348 mW/g

Maximum value of SAR (measured) = 0.543 mW/g

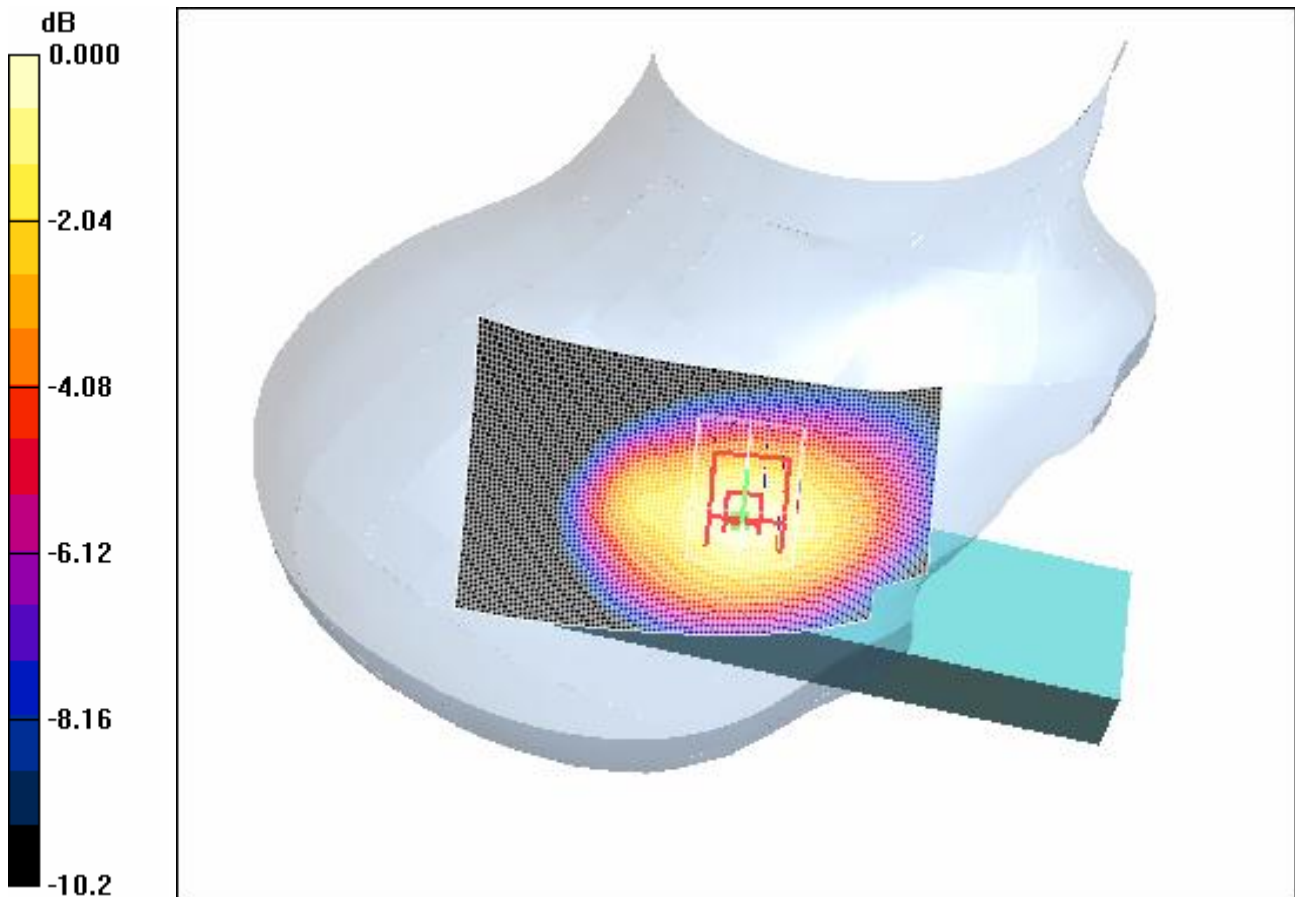

0 dB = 0.543mW/g

4.8 GSM850-RightHandSide-Cheek-Low-BYD

Date/Time: 2008-4-7 14:02:13

Test Laboratory: SGS-GSM

GSM850-RightHandSide-Cheek-Low-BYD

DUT: KJ005AE01; Type: Head; Serial: 011452000001826

Communication System: GSM850-GSM Mode; Frequency: 824.2 MHz; Duty Cycle: 1:8.3

Medium: HSL900-Head Medium parameters used: $f = 824.2$ MHz; $\sigma = 0.892$ mho/m; $\epsilon_r = 42.9$; $\rho = 1000$ kg/m³

Phantom section: Right Section

DASY4 Configuration:

- Probe: ES3DV3 - SN3088; ConvF(6.15, 6.15, 6.15); Calibrated: 2008-1-18
- Sensor-Surface: 4mm (Mechanical Surface Detection)
- Electronics: DAE3 Sn569; Calibrated: 2007-11-19
- Phantom: SAM 12; Type: SAM V4.0; Serial: TP-1283
- Measurement SW: DASY4, V4.7 Build 44; Postprocessing SW: SEMCAD, V1.8 Build 171

Cheek position - Low BYD/Area Scan (61x91x1): Measurement grid: dx=15mm, dy=15mm

Maximum value of SAR (interpolated) = 1.31 mW/g

Cheek position - Low BYD/Zoom Scan (7x7x7) (7x7x7)/Cube 0: Measurement grid: dx=5mm, dy=5mm, dz=5mm

Reference Value = 16.2 V/m; Power Drift = -0.212 dB

Peak SAR (extrapolated) = 1.62 W/kg

SAR(1 g) = 1.21 mW/g; SAR(10 g) = 0.829 mW/g

Maximum value of SAR (measured) = 1.30 mW/g

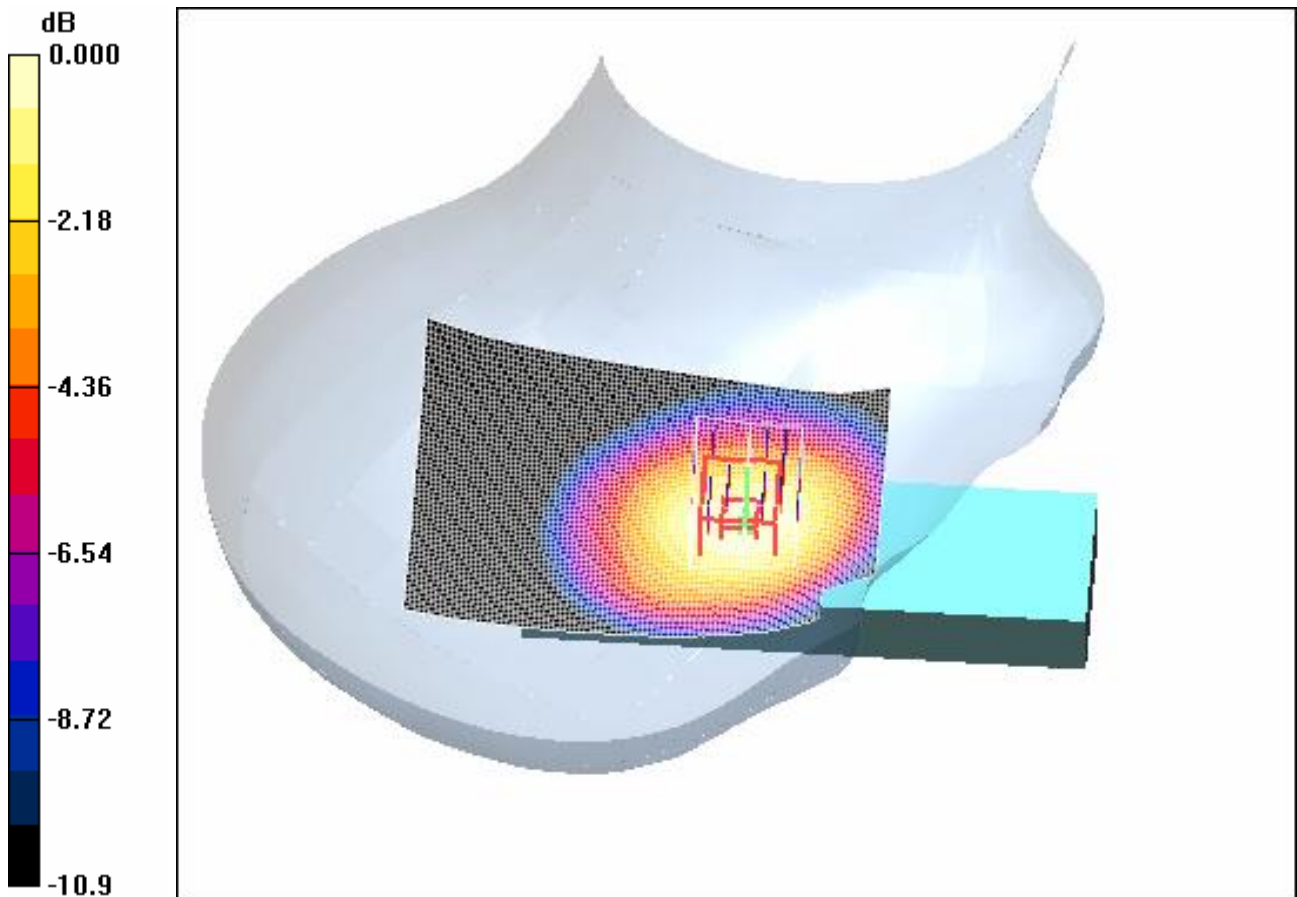

0 dB = 1.30mW/g

4.9 GSM850-RightHandSide-Cheek-High-BYD

Date/Time: 2008-4-7 14:52:16

Test Laboratory: SGS-GSM

GSM850-RightHandSide-Cheek-High-BYD

DUT: KJ005AE01; Type: Head; Serial: 011452000001826

Communication System: GSM850-GSM Mode; Frequency: 848.8 MHz; Duty Cycle: 1:8.3

Medium: HSL900-Head Medium parameters used: $f = 848.8$ MHz; $\sigma = 0.918$ mho/m; $\epsilon_r = 42.6$; $\rho = 1000$ kg/m³

Phantom section: Right Section

DASY4 Configuration:

- Probe: ES3DV3 - SN3088; ConvF(6.15, 6.15, 6.15); Calibrated: 2008-1-18
- Sensor-Surface: 4mm (Mechanical Surface Detection)
- Electronics: DAE3 Sn569; Calibrated: 2007-11-19
- Phantom: SAM 12; Type: SAM V4.0; Serial: TP-1283
- Measurement SW: DASY4, V4.7 Build 44; Postprocessing SW: SEMCAD, V1.8 Build 171

Cheek position - High BYD/Area Scan (61x91x1): Measurement grid: dx=15mm, dy=15mm

Maximum value of SAR (interpolated) = 0.998 mW/g

Cheek position - High BYD/Zoom Scan (7x7x7) (7x7x7)/Cube 0: Measurement grid: dx=5mm, dy=5mm, dz=5mm

Reference Value = 13.6 V/m; Power Drift = -0.058 dB

Peak SAR (extrapolated) = 1.23 W/kg

SAR(1 g) = 0.929 mW/g; SAR(10 g) = 0.635 mW/g

Maximum value of SAR (measured) = 1.00 mW/g

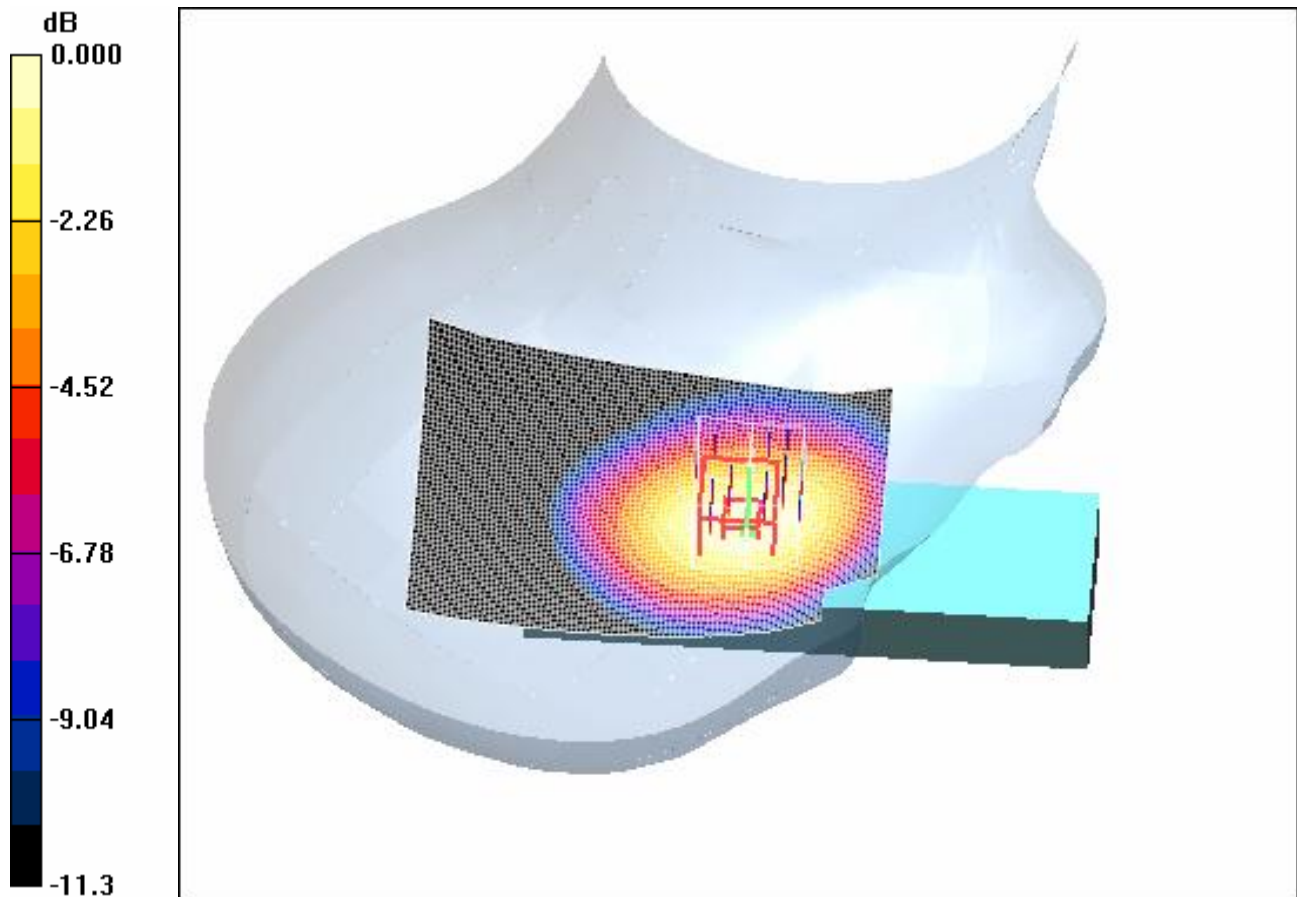

0 dB = 1.00mW/g

4.10 GSM850-RightHandSide-Cheek-Low-Coslight

Date/Time: 2008-4-7 16:07:35

Test Laboratory: SGS-GSM

GSM850-RightHandSide-Cheek-Low-Coslight

DUT: KJ005AE01; Type: Head; Serial: 011452000001826

Communication System: GSM850-GSM Mode; Frequency: 824.2 MHz; Duty Cycle: 1:8.3

Medium: HSL900-Head Medium parameters used: $f = 824.2$ MHz; $\sigma = 0.892$ mho/m; $\epsilon_r = 42.9$; $\rho = 1000$ kg/m³

Phantom section: Right Section

DASY4 Configuration:

- Probe: ES3DV3 - SN3088; ConvF(6.15, 6.15, 6.15); Calibrated: 2008-1-18
- Sensor-Surface: 4mm (Mechanical Surface Detection)
- Electronics: DAE3 Sn569; Calibrated: 2007-11-19
- Phantom: SAM 12; Type: SAM V4.0; Serial: TP-1283
- Measurement SW: DASY4, V4.7 Build 44; Postprocessing SW: SEMCAD, V1.8 Build 171

Cheek position - Low Coslight/Area Scan (61x91x1): Measurement grid: dx=15mm, dy=15mm
Maximum value of SAR (interpolated) = 1.37 mW/g

Cheek position - Low Coslight/Zoom Scan (7x7x7)/Cube 0: Measurement grid: dx=5mm, dy=5mm,
dz=5mm

Reference Value = 15.4 V/m; Power Drift = -0.169 dB

Peak SAR (extrapolated) = 1.69 W/kg

SAR(1 g) = 1.26 mW/g; SAR(10 g) = 0.866 mW/g

Maximum value of SAR (measured) = 1.37 mW/g

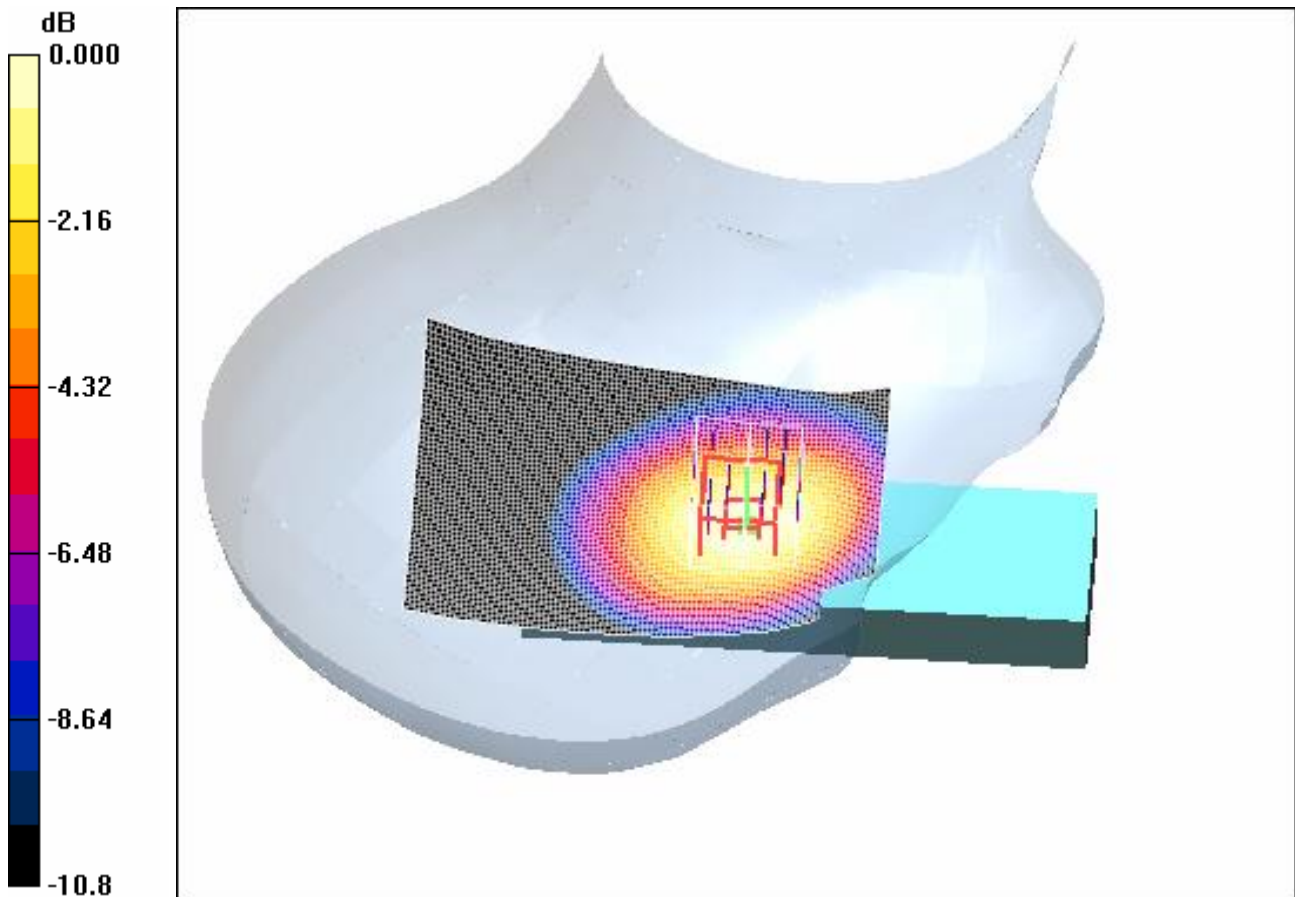

0 dB = 1.37mW/g

4.11 GSM850-Body-Worn -Low-BYD-Headset CCA3010000E0

Date/Time: 2008-4-15 13:02:14

Test Laboratory: SGS-GSM

GSM850-Body-Worn-Low-2.0cm-BYD- Headset CCA3010000E0

DUT: KJ005AE01; Type: Head; Serial: 011452000001826

Communication System: GSM850-GSM Mode; Frequency: 824.2 MHz;Duty Cycle: 1:8.3

Medium: HSL 850_Body Medium parameters used: $f = 824.2$ MHz; $\sigma = 0.964$ mho/m; $\epsilon_r = 53.2$; $\rho = 1000$ kg/m³

Phantom section: Flat Section

DASY4 Configuration:

- Probe: ES3DV3 - SN3088; ConvF(5.81, 5.81, 5.81); Calibrated: 2008-1-18
- Sensor-Surface: 4mm (Mechanical Surface Detection)
- Electronics: DAE3 Sn569; Calibrated: 2007-11-19
- Phantom: SAM 12; Type: SAM V4.0; Serial: TP-1283
- Measurement SW: DASY4, V4.7 Build 44; Postprocessing SW: SEMCAD, V1.8 Build 171

Body Worn - Low BYD/Area Scan (51x91x1): Measurement grid: dx=15mm, dy=15mm
Maximum value of SAR (interpolated) = 0.804 mW/g

Body Worn - Low BYD/Zoom Scan (7x7x7) (7x7x7)/Cube 0: Measurement grid: dx=5mm,
dy=5mm, dz=5mm

Reference Value = 15.8 V/m; Power Drift = -0.023 dB

Peak SAR (extrapolated) = 0.986 W/kg

SAR(1 g) = 0.738 mW/g; SAR(10 g) = 0.527 mW/g

Maximum value of SAR (measured) = 0.782 mW/g

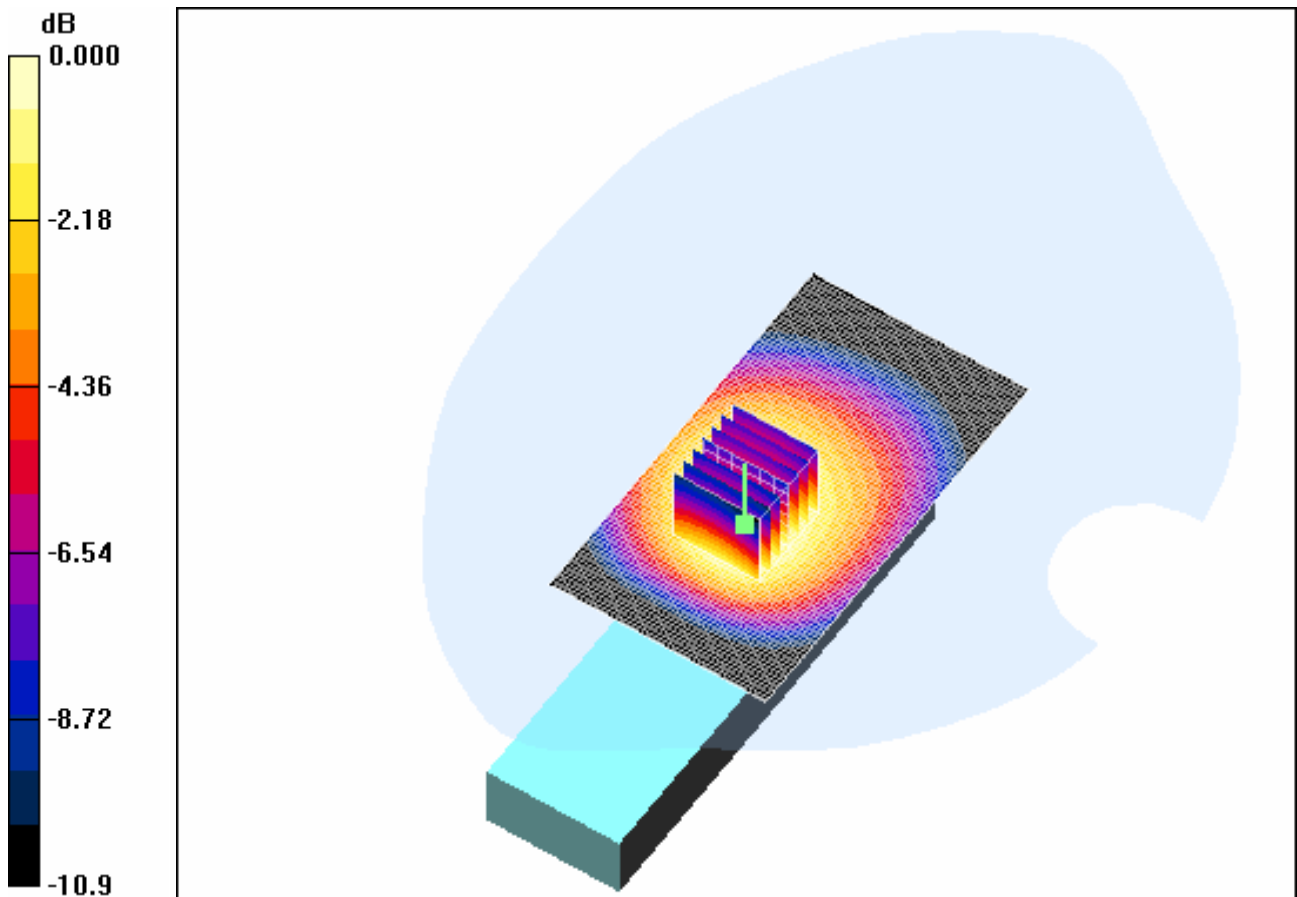

0 dB = 0.782mW/g

4.12 GSM850-Body-Worn -Middle-BYD-Headset CCA3010000E0

Date/Time: 2008-4-15 13:44:32

Test Laboratory: SGS-GSM

GSM850-Body-Worn-Middle-2.0cm-BYD-Headset CCA3010000E0

DUT: KJ005AE01; Type: Head; Serial: 011452000001826

Communication System: GSM850-GSM Mode; Frequency: 836.4 MHz; Duty Cycle: 1:8.3

Medium: HSL 850_Body Medium parameters used: $f = 836.4$ MHz; $\sigma = 0.98$ mho/m; $\epsilon_r = 53.1$; $\rho = 1000$ kg/m³

Phantom section: Flat Section

DASY4 Configuration:

- Probe: ES3DV3 - SN3088; ConvF(5.81, 5.81, 5.81); Calibrated: 2008-1-18
- Sensor-Surface: 4mm (Mechanical Surface Detection)
- Electronics: DAE3 Sn569; Calibrated: 2007-11-19
- Phantom: SAM 12; Type: SAM V4.0; Serial: TP-1283
- Measurement SW: DASY4, V4.7 Build 44; Postprocessing SW: SEMCAD, V1.8 Build 171

Body Worn - Middle BYD/Area Scan (51x91x1): Measurement grid: dx=15mm, dy=15mm
Maximum value of SAR (interpolated) = 0.665 mW/g

Body Worn - Middle BYD/Zoom Scan (7x7x7)/Cube 0: Measurement grid: dx=5mm, dy=5mm,
dz=5mm

Reference Value = 14.2 V/m; Power Drift = -0.045 dB

Peak SAR (extrapolated) = 0.828 W/kg

SAR(1 g) = 0.615 mW/g; SAR(10 g) = 0.438 mW/g

Maximum value of SAR (measured) = 0.650 mW/g

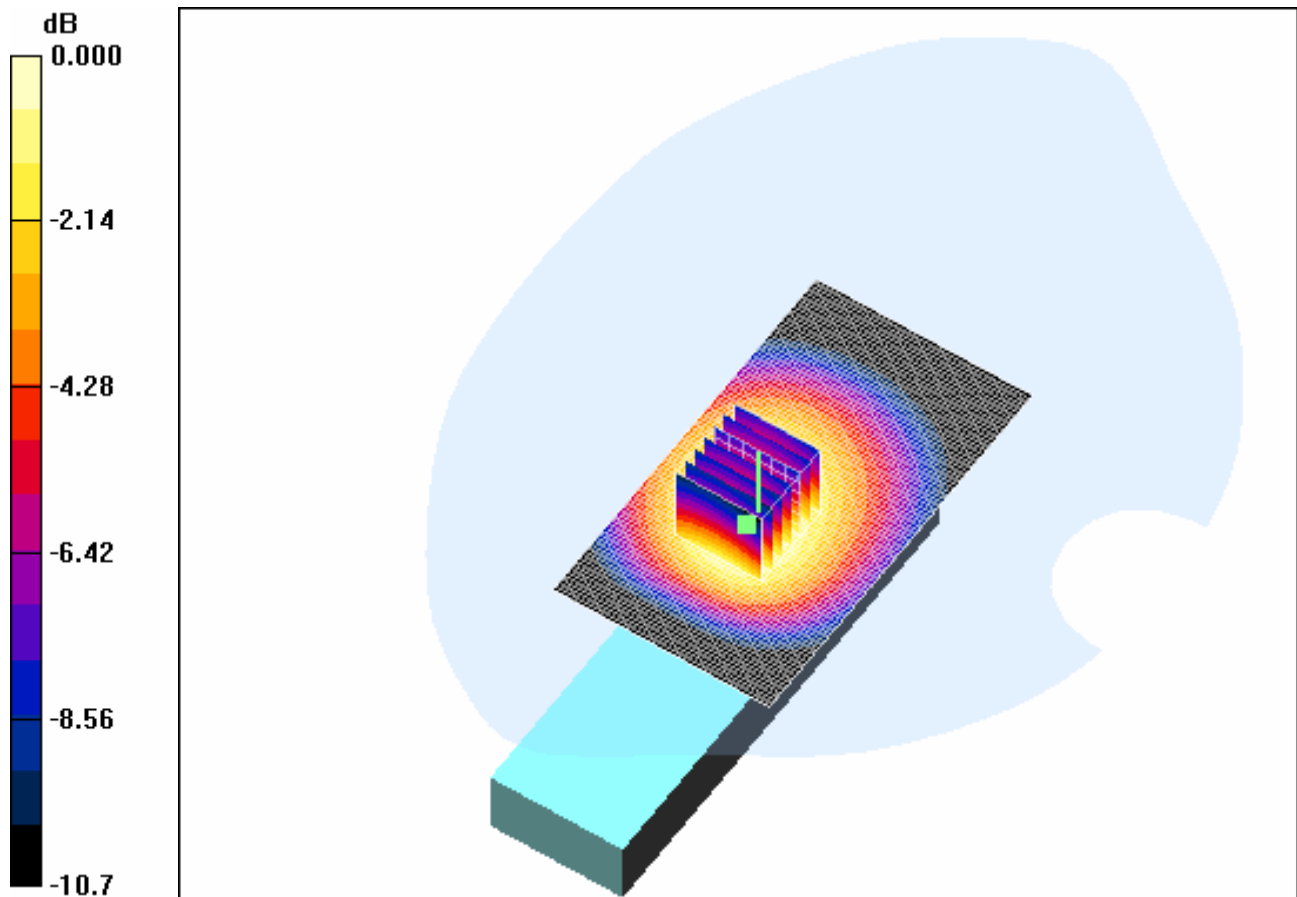

0 dB = 0.650mW/g

4.13 GSM850-Body-Worn -High-BYD-Headset CCA3010000E0

Date/Time: 2008-4-15 14:15:26

Test Laboratory: SGS-GSM

GSM850-Body-Worn-High-2.0cm-BYD-Headset CCA3010000E0

DUT: KJ005AE01; Type: Head; Serial: 011452000001826

Communication System: GSM850-GSM Mode; Frequency: 848.8 MHz;Duty Cycle: 1:8.3

Medium: HSL 850_Body Medium parameters used: $f = 848.8$ MHz; $\sigma = 0.994$ mho/m; $\epsilon_r = 53.1$; $\rho = 1000$ kg/m³

Phantom section: Flat Section

DASY4 Configuration:

- Probe: ES3DV3 - SN3088; ConvF(5.81, 5.81, 5.81); Calibrated: 2008-1-18
- Sensor-Surface: 4mm (Mechanical Surface Detection)
- Electronics: DAE3 Sn569; Calibrated: 2007-11-19
- Phantom: SAM 12; Type: SAM V4.0; Serial: TP-1283
- Measurement SW: DASY4, V4.7 Build 44; Postprocessing SW: SEMCAD, V1.8 Build 171

Body Worn - High BYD/Area Scan (51x91x1): Measurement grid: dx=15mm, dy=15mm

Maximum value of SAR (interpolated) = 0.583 mW/g

Body Worn - High BYD/Zoom Scan (7x7x7) (7x7x7)/Cube 0: Measurement grid: dx=5mm,
dy=5mm, dz=5mm

Reference Value = 13.3 V/m; Power Drift = -0.032 dB

Peak SAR (extrapolated) = 0.738 W/kg

SAR(1 g) = 0.547 mW/g; SAR(10 g) = 0.388 mW/g

Maximum value of SAR (measured) = 0.579 mW/g

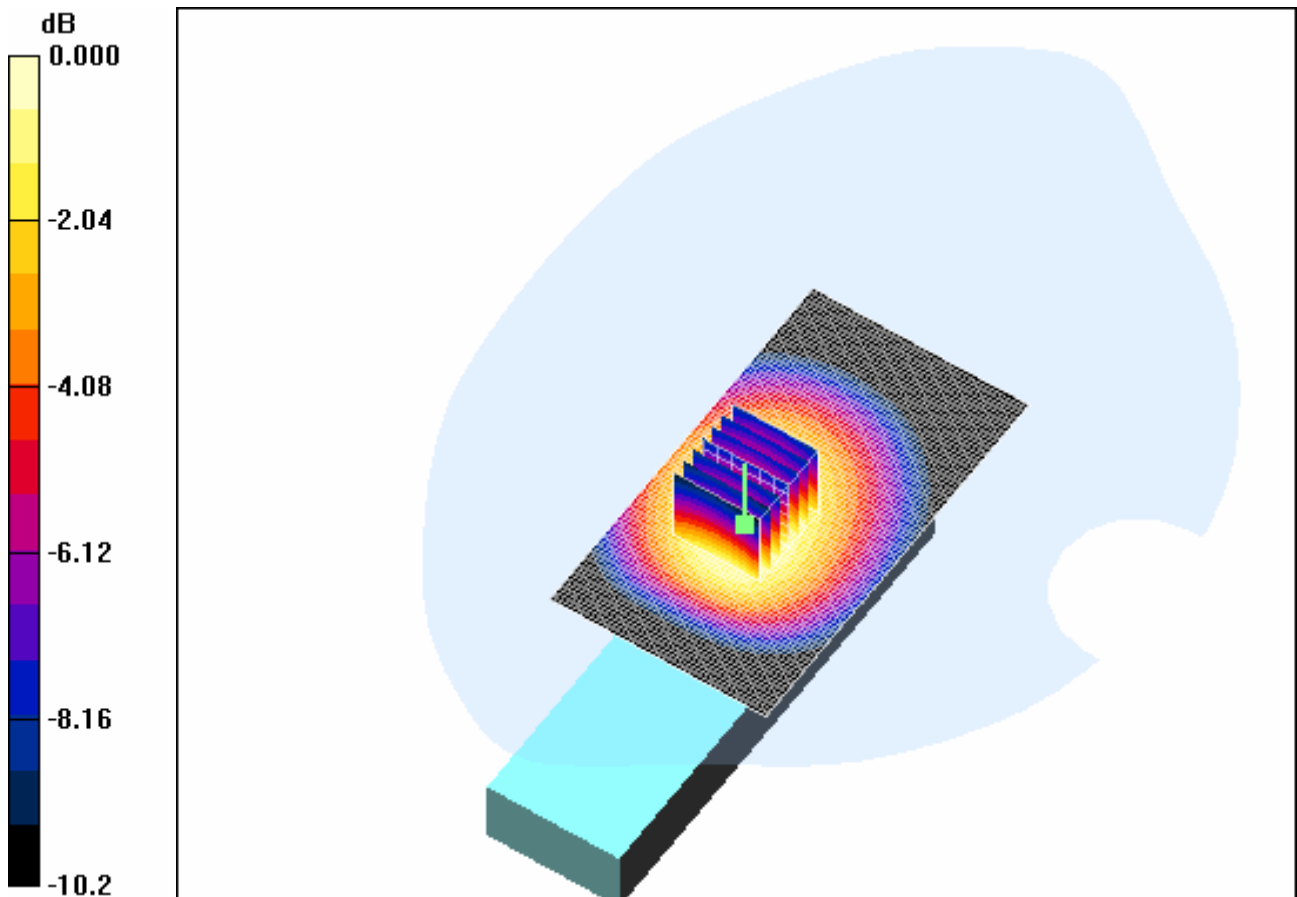

0 dB = 0.579mW/g

4.14 GSM850-Body-Worn -Low-Coslight-Headset CCA3010000E0

Date/Time: 2008-4-15 14:40:28

Test Laboratory: SGS-GSM

GSM850-Body-Worn-Low-2.0cm-Coslight-Headset CCA3010000E0

DUT: KJ005AE01; Type: Head; Serial: 011452000001826

Communication System: GSM850-GSM Mode; Frequency: 824.2 MHz; Duty Cycle: 1:8.3

Medium: HSL 850_Body Medium parameters used: $f = 824.2$ MHz; $\sigma = 0.964$ mho/m; $\epsilon_r = 53.2$; $\rho =$

1000 kg/m³

Phantom section: Flat Section

DASY4 Configuration:

- Probe: ES3DV3 - SN3088; ConvF(5.81, 5.81, 5.81); Calibrated: 2008-1-18
- Sensor-Surface: 4mm (Mechanical Surface Detection)
- Electronics: DAE3 Sn569; Calibrated: 2007-11-19
- Phantom: SAM 12; Type: SAM V4.0; Serial: TP-1283
- Measurement SW: DASY4, V4.7 Build 44; Postprocessing SW: SEMCAD, V1.8 Build 171

Body Worn - Low Coslight/Area Scan (51x91x1): Measurement grid: dx=15mm, dy=15mm

Maximum value of SAR (interpolated) = 0.752 mW/g

Body Worn - Low Coslight/Zoom Scan (7x7x7) (7x7x7)/Cube 0: Measurement grid: dx=5mm, dy=5mm, dz=5mm

Reference Value = 16.3 V/m; Power Drift = -0.002 dB

Peak SAR (extrapolated) = 0.923 W/kg

SAR(1 g) = 0.700 mW/g; SAR(10 g) = 0.506 mW/g

Maximum value of SAR (measured) = 0.740 mW/g

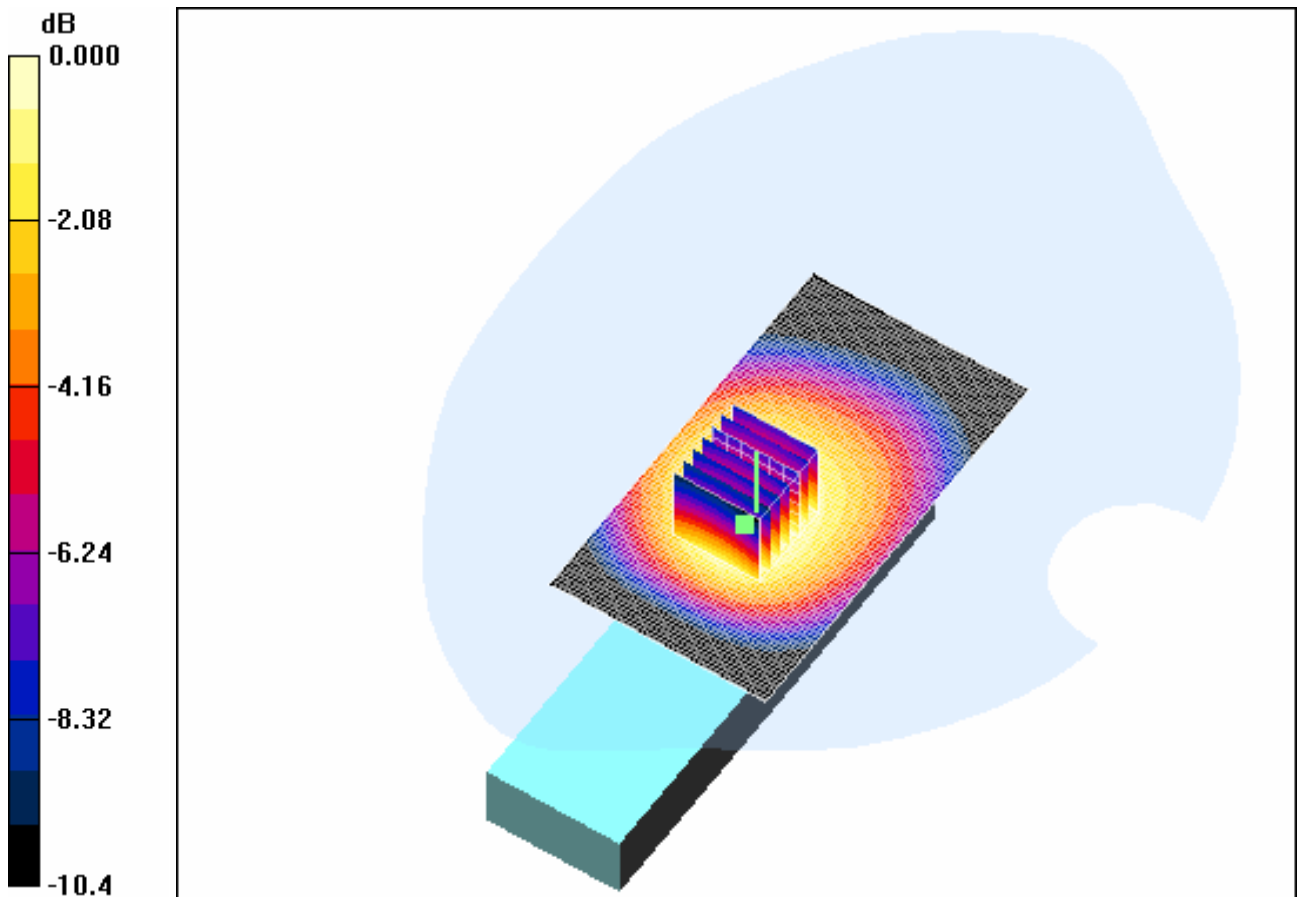

0 dB = 0.740mW/g

4.15 PCS1900-LeftHandSide-Cheek-Middle-BYD

Date/Time: 2008-4-10 14:10:41

Test Laboratory: SGS-GSM

PCS1900-LeftHandSide-Cheek-Middle-BYD

DUT: KJ005AE01; Type: Head; Serial: 011452000001826

Communication System: PCS1900-GSM Mode; Frequency: 1880 MHz; Duty Cycle: 1:8.3

Medium: HSL1900_Head Medium parameters used: $f = 1880$ MHz; $\sigma = 1.4$ mho/m; $\epsilon_r = 39$; $\rho = 1000$

kg/m³

Phantom section: Left Section

DASY4 Configuration:

- Probe: ES3DV3 - SN3088; ConvF(4.84, 4.84, 4.84); Calibrated: 2008-1-18
- Sensor-Surface: 4mm (Mechanical Surface Detection)
- Electronics: DAE3 Sn569; Calibrated: 2007-11-19
- Phantom: SAM 12; Type: SAM V4.0; Serial: TP-1283
- Measurement SW: DASY4, V4.7 Build 44; Postprocessing SW: SEMCAD, V1.8 Build 171

Cheek position - Middle BYD/Area Scan (61x81x1): Measurement grid: dx=15mm, dy=15mm

Maximum value of SAR (interpolated) = 0.917 mW/g

Cheek position - Middle BYD/Zoom Scan (7x7x7)/Cube 0: Measurement grid: dx=5mm, dy=5mm, dz=5mm

Reference Value = 6.14 V/m; Power Drift = -0.112 dB

Peak SAR (extrapolated) = 1.28 W/kg

SAR(1 g) = 0.788 mW/g; SAR(10 g) = 0.476 mW/g

Maximum value of SAR (measured) = 0.863 mW/g

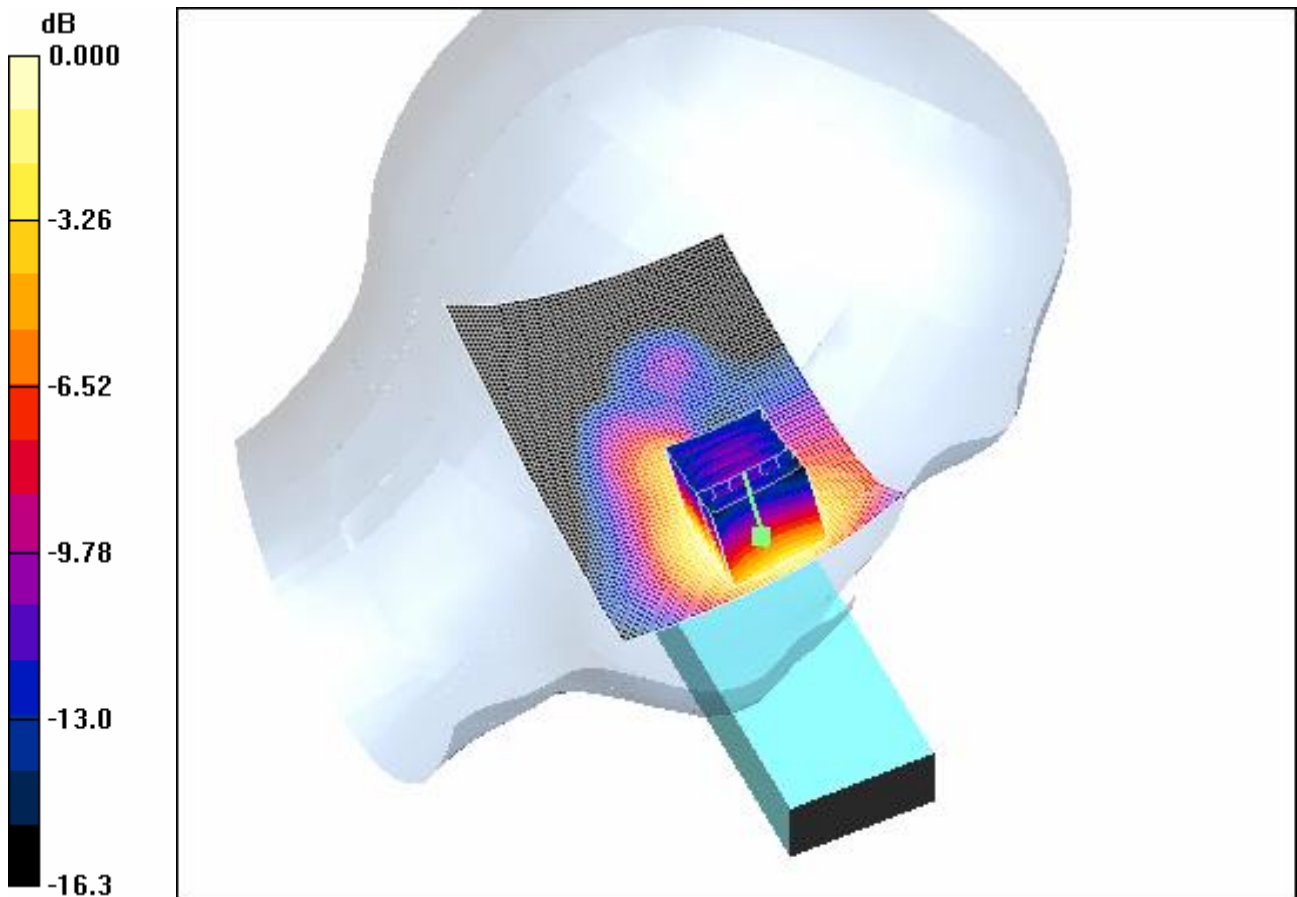

0 dB = 0.863mW/g

4.16 PCS1900-LeftHandSide-Tilt-Middle-BYD

Date/Time: 2008-4-10 15:43:07

Test Laboratory: SGS-GSM

PCS1900-LeftHandSide-Tilt-Middle-BYD

DUT: KJ005AE01; Type: Head; Serial: 011452000001826

Communication System: PCS1900-GSM Mode; Frequency: 1880 MHz; Duty Cycle: 1:8.3

Medium: HSL1900_Head Medium parameters used: $f = 1880$ MHz; $\sigma = 1.4$ mho/m; $\epsilon_r = 39$; $\rho = 1000$ kg/m³

Phantom section: Left Section

DASY4 Configuration:

- Probe: ES3DV3 - SN3088; ConvF(4.84, 4.84, 4.84); Calibrated: 2008-1-18
- Sensor-Surface: 4mm (Mechanical Surface Detection)
- Electronics: DAE3 Sn569; Calibrated: 2007-11-19
- Phantom: SAM 12; Type: SAM V4.0; Serial: TP-1283
- Measurement SW: DASY4, V4.7 Build 44; Postprocessing SW: SEMCAD, V1.8 Build 171

Tilt position - Middle BYD/Area Scan (61x81x1): Measurement grid: dx=15mm, dy=15mm

Maximum value of SAR (interpolated) = 0.177 mW/g

Tilt position - Middle BYD/Zoom Scan (7x7x7)/Cube 0: Measurement grid: dx=5mm, dy=5mm, dz=5mm

Reference Value = 8.77 V/m; Power Drift = 0.002 dB

Peak SAR (extrapolated) = 0.269 W/kg

SAR(1 g) = 0.170 mW/g; SAR(10 g) = 0.103 mW/g

Maximum value of SAR (measured) = 0.186 mW/g

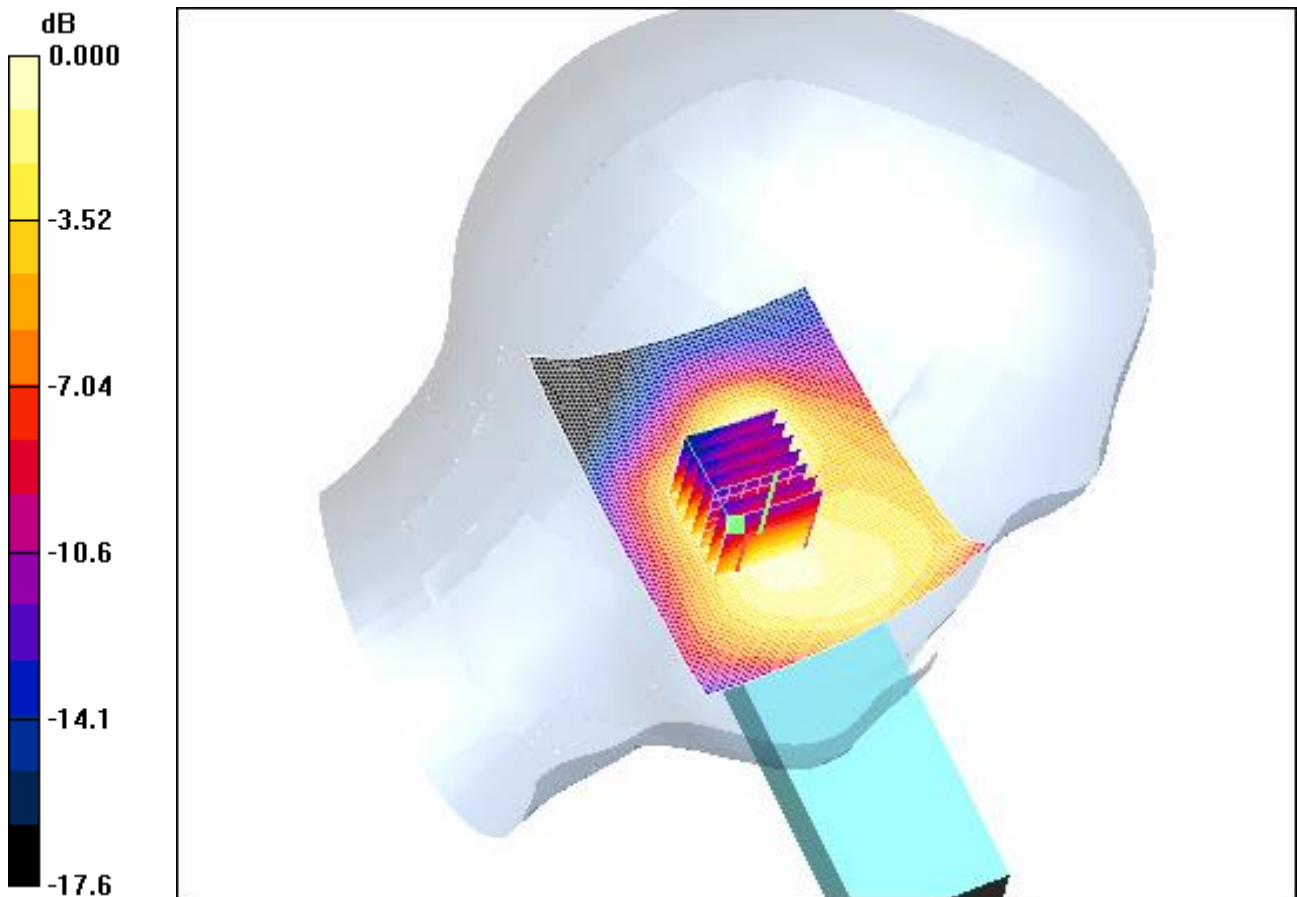

0 dB = 0.186mW/g

4.17 PCS1900-LeftHandSide-Cheek-Low-BYD

Date/Time: 2008-4-10 14:35:37

Test Laboratory: SGS-GSM

PCS1900-LeftHandSide-Cheek-Low-BYD

DUT: KJ005AE01; Type: Head; Serial: 011452000001826

Communication System: PCS1900-GSM Mode; Frequency: 1850.2 MHz; Duty Cycle: 1:8.3

Medium: HSL1900_Head Medium parameters used: $f = 1850.2$ MHz; $\sigma = 1.37$ mho/m; $\epsilon_r = 39.1$; $\rho = 1000$ kg/m³

Phantom section: Left Section

DASY4 Configuration:

- Probe: ES3DV3 - SN3088; ConvF(4.84, 4.84, 4.84); Calibrated: 2008-1-18
- Sensor-Surface: 4mm (Mechanical Surface Detection)
- Electronics: DAE3 Sn569; Calibrated: 2007-11-19
- Phantom: SAM 12; Type: SAM V4.0; Serial: TP-1283
- Measurement SW: DASY4, V4.7 Build 44; Postprocessing SW: SEMCAD, V1.8 Build 171

Cheek position - Low BYD/Area Scan (61x81x1): Measurement grid: dx=15mm, dy=15mm
Maximum value of SAR (interpolated) = 0.904 mW/g

Cheek position - Low BYD/Zoom Scan (7x7x7) (7x7x7)/Cube 0: Measurement grid: dx=5mm,
dy=5mm, dz=5mm

Reference Value = 7.27 V/m; Power Drift = 0.013 dB

Peak SAR (extrapolated) = 1.27 W/kg

SAR(1 g) = 0.781 mW/g; SAR(10 g) = 0.470 mW/g

Maximum value of SAR (measured) = 0.845 mW/g

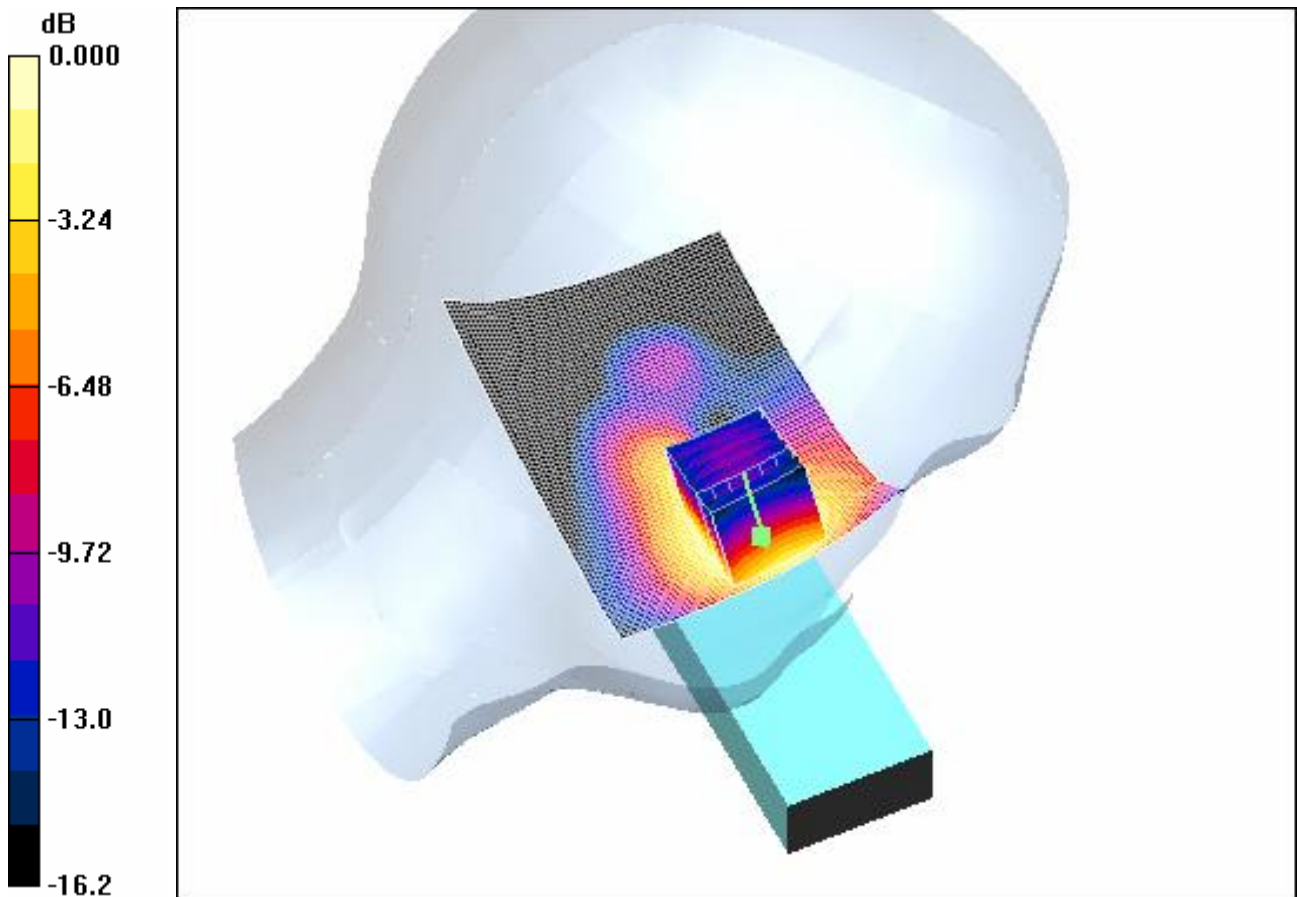

0 dB = 0.845mW/g

4.18 PCS1900-LeftHandSide-Cheek-High-BYD

Date/Time: 2008-4-10 15:14:11

Test Laboratory: SGS-GSM

PCS1900-LeftHandSide-Cheek-High-BYD

DUT: KJ005AE01; Type: Head; Serial: 011452000001826

Communication System: PCS1900-GSM Mode; Frequency: 1909.8 MHz; Duty Cycle: 1:8.3

Medium: HSL1900_Head Medium parameters used: $f = 1909.8$ MHz; $\sigma = 1.43$ mho/m; $\epsilon_r = 38.9$; $\rho = 1000$ kg/m³

Phantom section: Left Section

DASY4 Configuration:

- Probe: ES3DV3 - SN3088; ConvF(4.84, 4.84, 4.84); Calibrated: 2008-1-18
- Sensor-Surface: 4mm (Mechanical Surface Detection)
- Electronics: DAE3 Sn569; Calibrated: 2007-11-19
- Phantom: SAM 12; Type: SAM V4.0; Serial: TP-1283
- Measurement SW: DASY4, V4.7 Build 44; Postprocessing SW: SEMCAD, V1.8 Build 171

Cheek position - High/Area Scan (61x81x1): Measurement grid: dx=15mm, dy=15mm

Maximum value of SAR (interpolated) = 0.824 mW/g

Cheek position - High/Zoom Scan (7x7x7) (7x7x7)/Cube 0: Measurement grid: dx=5mm, dy=5mm, dz=5mm

Reference Value = 5.44 V/m; Power Drift = 0.003 dB

Peak SAR (extrapolated) = 1.14 W/kg

SAR(1 g) = 0.711 mW/g; SAR(10 g) = 0.427 mW/g

Maximum value of SAR (measured) = 0.765 mW/g

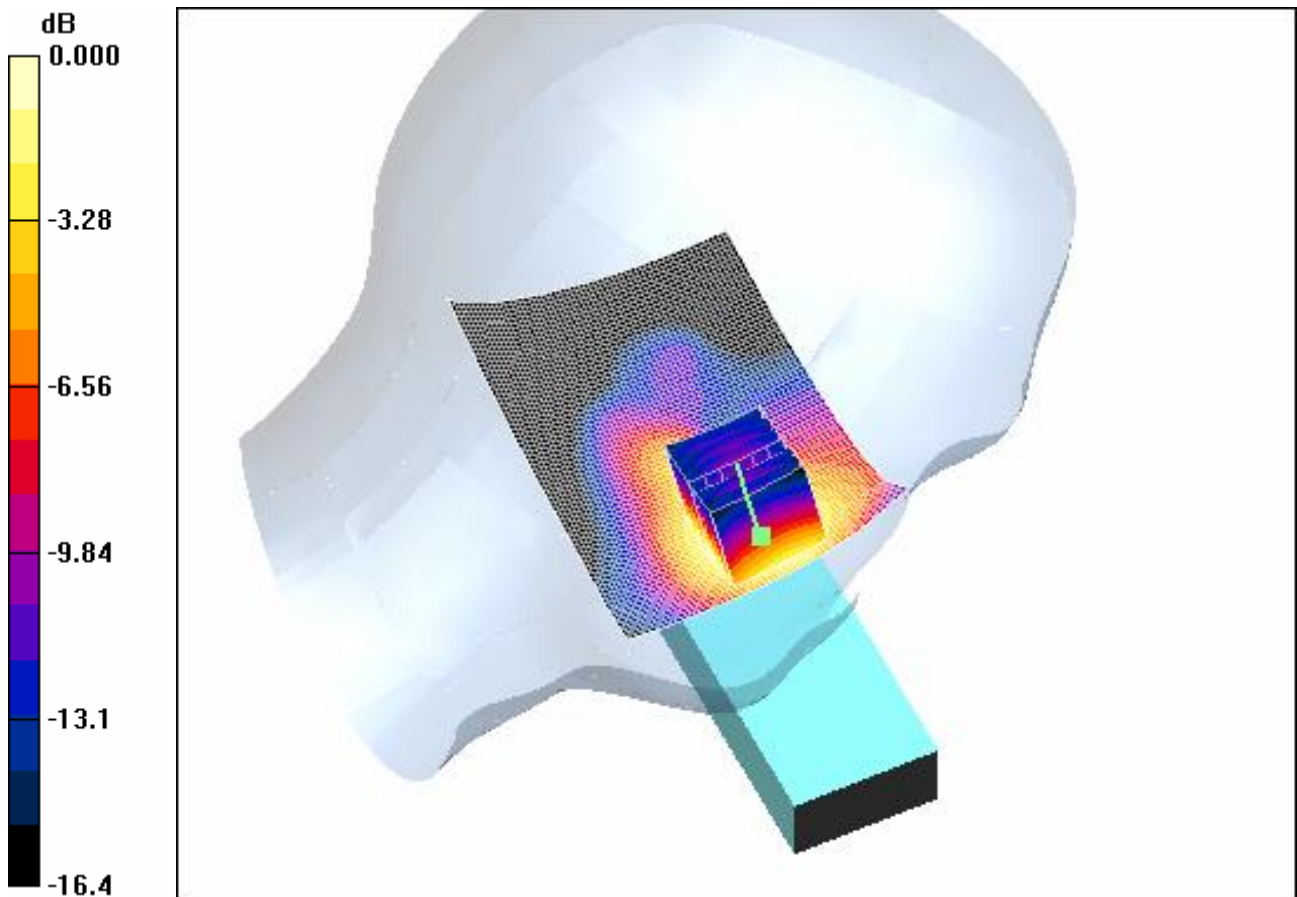

0 dB = 0.765mW/g

4.19 PCS1900-LeftHandSide-Cheek-Middle-Coslight

Date/Time: 2008-4-11 8:23:10

Test Laboratory: SGS-GSM

PCS1900-LeftHandSide-Cheek-Middle-Coslight

DUT: KJ005AE01; Type: Head; Serial: 011452000001826

Communication System: PCS1900-GSM Mode; Frequency: 1880 MHz; Duty Cycle: 1:8.3

Medium: HSL1900_Head Medium parameters used: $f = 1880$ MHz; $\sigma = 1.4$ mho/m; $\epsilon_r = 39$; $\rho = 1000$ kg/m³

Phantom section: Left Section

DASY4 Configuration:

- Probe: ES3DV3 - SN3088; ConvF(4.84, 4.84, 4.84); Calibrated: 2008-1-18
- Sensor-Surface: 4mm (Mechanical Surface Detection)
- Electronics: DAE3 Sn569; Calibrated: 2007-11-19
- Phantom: SAM 12; Type: SAM V4.0; Serial: TP-1283
- Measurement SW: DASY4, V4.7 Build 44; Postprocessing SW: SEMCAD, V1.8 Build 171

Cheek position - Middle Coslight/Area Scan (61x81x1): Measurement grid: dx=15mm, dy=15mm
Maximum value of SAR (interpolated) = 0.930 mW/g

Cheek position - Middle Coslight/Zoom Scan (7x7x7) (7x7x7)/Cube 0: Measurement grid:
dx=5mm, dy=5mm, dz=5mm

Reference Value = 11.1 V/m; Power Drift = -0.126 dB

Peak SAR (extrapolated) = 1.42 W/kg

SAR(1 g) = 0.837 mW/g; SAR(10 g) = 0.491 mW/g

Maximum value of SAR (measured) = 0.922 mW/g

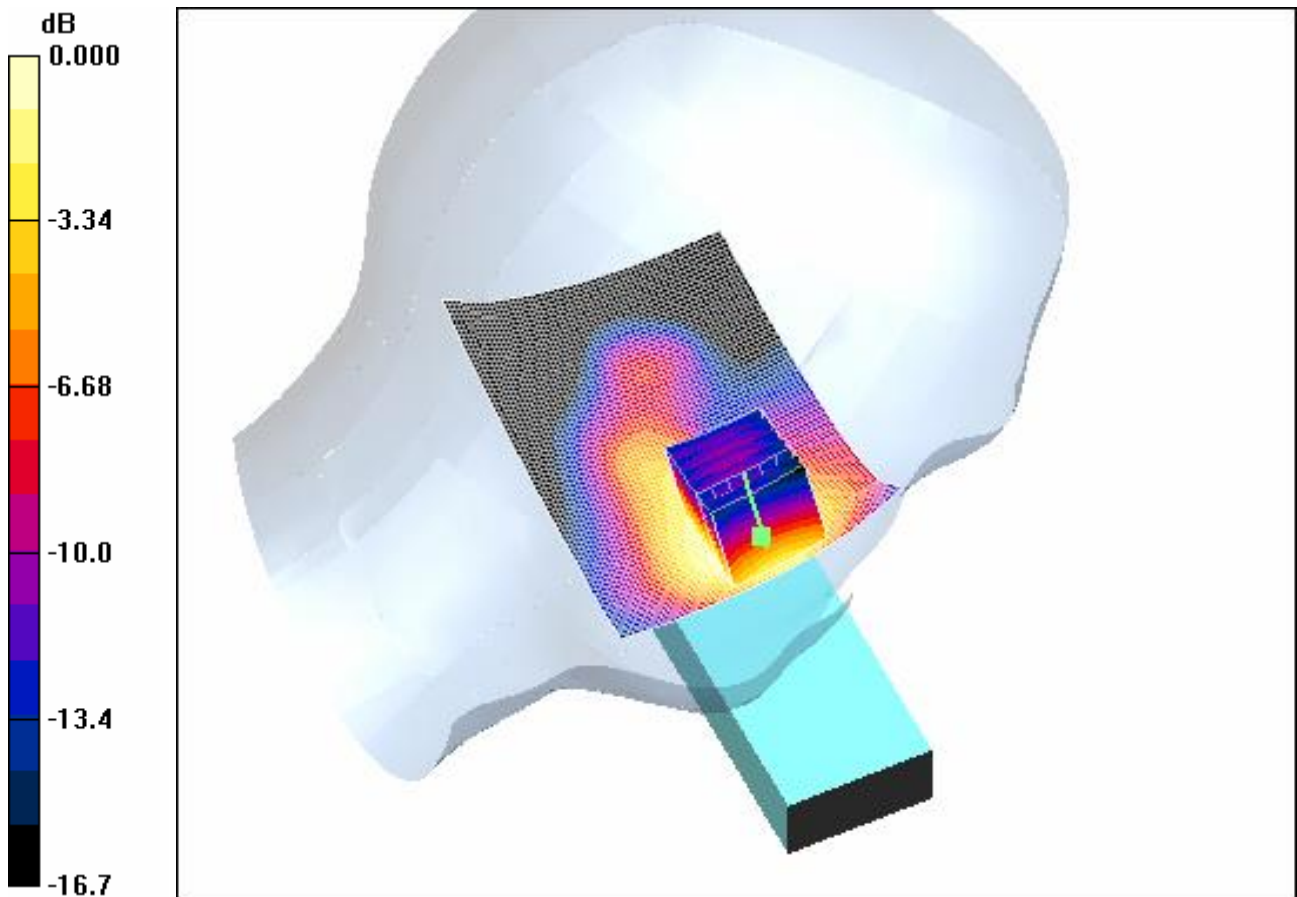

0 dB = 0.922mW/g

4.20 PCS1900-RightHandSide-Cheek-Middle-BYD

Date/Time: 2008-4-10 9:32:32

Test Laboratory: SGS-GSM

PCS1900-RightHandSide-Cheek-Middle-BYD

DUT: KJ005AE01; Type: Head; Serial: 011452000001826

Communication System: PCS1900-GSM Mode; Frequency: 1880 MHz; Duty Cycle: 1:8.3

Medium: HSL1900_Head Medium parameters used: $f = 1880$ MHz; $\sigma = 1.4$ mho/m; $\epsilon_r = 39$; $\rho = 1000$ kg/m³

Phantom section: Right Section

DASY4 Configuration:

- Probe: ES3DV3 - SN3088; ConvF(4.84, 4.84, 4.84); Calibrated: 2008-1-18
- Sensor-Surface: 4mm (Mechanical Surface Detection)
- Electronics: DAE3 Sn569; Calibrated: 2007-11-19
- Phantom: SAM 12; Type: SAM V4.0; Serial: TP-1283
- Measurement SW: DASY4, V4.7 Build 44; Postprocessing SW: SEMCAD, V1.8 Build 171

Cheek position - Middle BYD/Area Scan (61x81x1): Measurement grid: dx=15mm, dy=15mm

Maximum value of SAR (interpolated) = 1.40 mW/g

Cheek position - Middle BYD/Zoom Scan (7x7x7)/Cube 0: Measurement grid: dx=5mm, dy=5mm, dz=5mm

Reference Value = 6.96 V/m; Power Drift = -0.006 dB

Peak SAR (extrapolated) = 1.98 W/kg

SAR(1 g) = 1.19 mW/g; SAR(10 g) = 0.665 mW/g

Maximum value of SAR (measured) = 1.33 mW/g

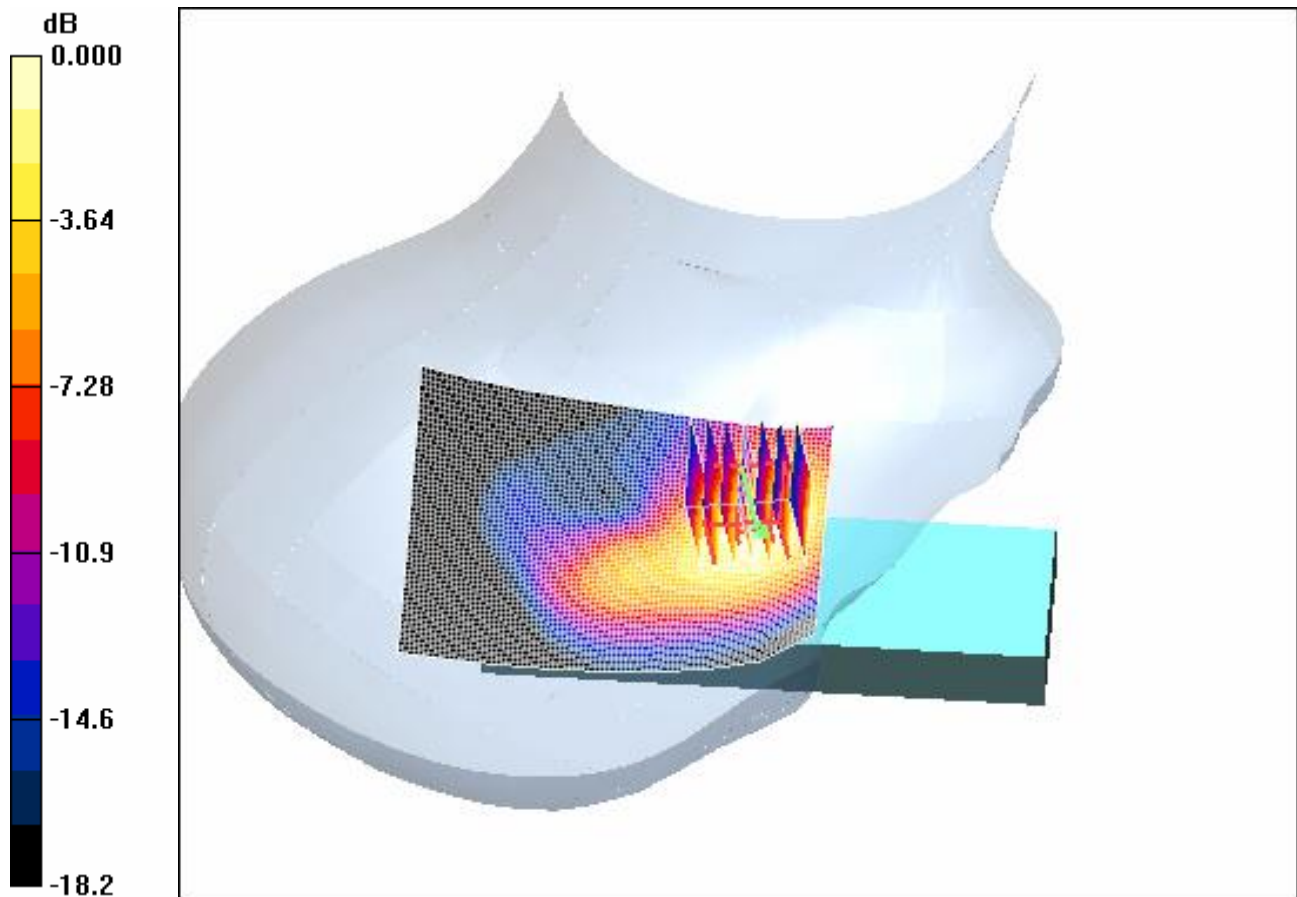

0 dB = 1.33mW/g

4.21 PCS1900-RightHandSide-Tilt-Middle-BYD

Date/Time: 2008-4-10 11:11:11

Test Laboratory: SGS-GSM

PCS1900-RightHandSide-Tilt-Middle-BYD

DUT: KJ005AE01; Type: Head; Serial: 011452000001826

Communication System: PCS1900-GSM Mode; Frequency: 1880 MHz; Duty Cycle: 1:8.3

Medium: HSL1900_Head Medium parameters used: $f = 1880$ MHz; $\sigma = 1.4$ mho/m; $\epsilon_r = 39$; $\rho = 1000$ kg/m³

Phantom section: Right Section

DASY4 Configuration:

- Probe: ES3DV3 - SN3088; ConvF(4.84, 4.84, 4.84); Calibrated: 2008-1-18
- Sensor-Surface: 4mm (Mechanical Surface Detection)
- Electronics: DAE3 Sn569; Calibrated: 2007-11-19
- Phantom: SAM 12; Type: SAM V4.0; Serial: TP-1283
- Measurement SW: DASY4, V4.7 Build 44; Postprocessing SW: SEMCAD, V1.8 Build 171

Tilt position - Middle BYD/Area Scan (61x81x1): Measurement grid: dx=15mm, dy=15mm

Maximum value of SAR (interpolated) = 0.247 mW/g

Tilt position - Middle BYD/Zoom Scan (7x7x7)/Cube 0: Measurement grid: dx=5mm, dy=5mm, dz=5mm

Reference Value = 9.26 V/m; Power Drift = -0.032 dB

Peak SAR (extrapolated) = 0.348 W/kg

SAR(1 g) = 0.217 mW/g; SAR(10 g) = 0.126 mW/g

Maximum value of SAR (measured) = 0.238 mW/g

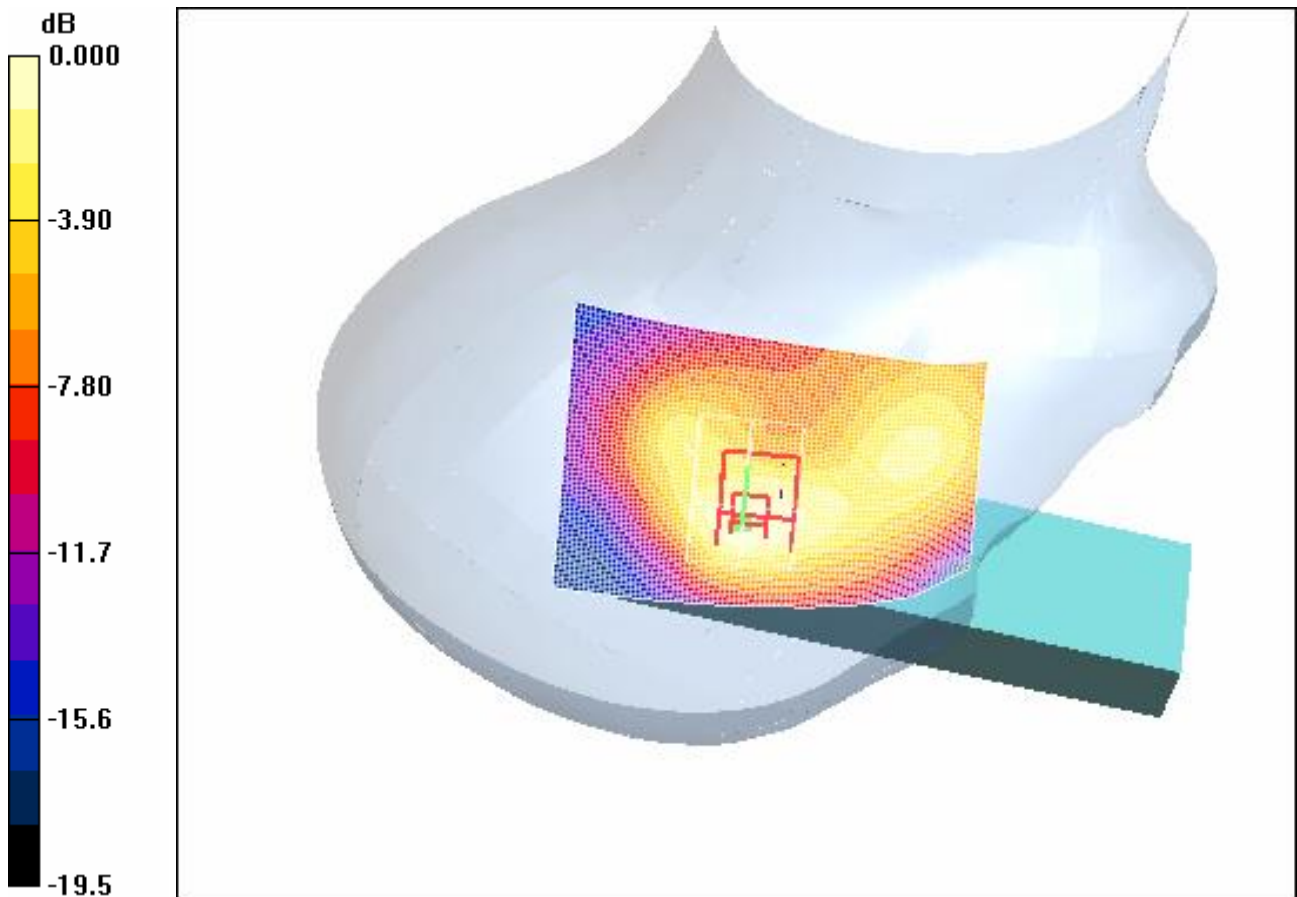

0 dB = 0.238mW/g

4.22 PCS1900-RightHandSide-Cheek-Low-BYD

Date/Time: 2008-4-10 10:28:33

Test Laboratory: SGS-GSM

PCS1900-RightHandSide-Cheek-Low-BYD

DUT: KJ005AE01; Type: Head; Serial: 011452000001826

Communication System: PCS1900-GSM Mode; Frequency: 1850.2 MHz; Duty Cycle: 1:8.3

Medium: HSL1900_Head Medium parameters used: $f = 1850.2$ MHz; $\sigma = 1.37$ mho/m; $\epsilon_r = 39.1$; $\rho = 1000$ kg/m³

Phantom section: Right Section

DASY4 Configuration:

- Probe: ES3DV3 - SN3088; ConvF(4.84, 4.84, 4.84); Calibrated: 2008-1-18
- Sensor-Surface: 4mm (Mechanical Surface Detection)
- Electronics: DAE3 Sn569; Calibrated: 2007-11-19
- Phantom: SAM 12; Type: SAM V4.0; Serial: TP-1283
- Measurement SW: DASY4, V4.7 Build 44; Postprocessing SW: SEMCAD, V1.8 Build 171

Cheek position - Low BYD/Area Scan (61x81x1): Measurement grid: dx=15mm, dy=15mm
Maximum value of SAR (interpolated) = 1.36 mW/g

Cheek position - Low BYD/Zoom Scan (7x7x7) (7x7x7)/Cube 0: Measurement grid: dx=5mm,
dy=5mm, dz=5mm

Reference Value = 8.18 V/m; Power Drift = 0.075 dB

Peak SAR (extrapolated) = 1.99 W/kg

SAR(1 g) = 1.18 mW/g; SAR(10 g) = 0.650 mW/g

Maximum value of SAR (measured) = 1.31 mW/g

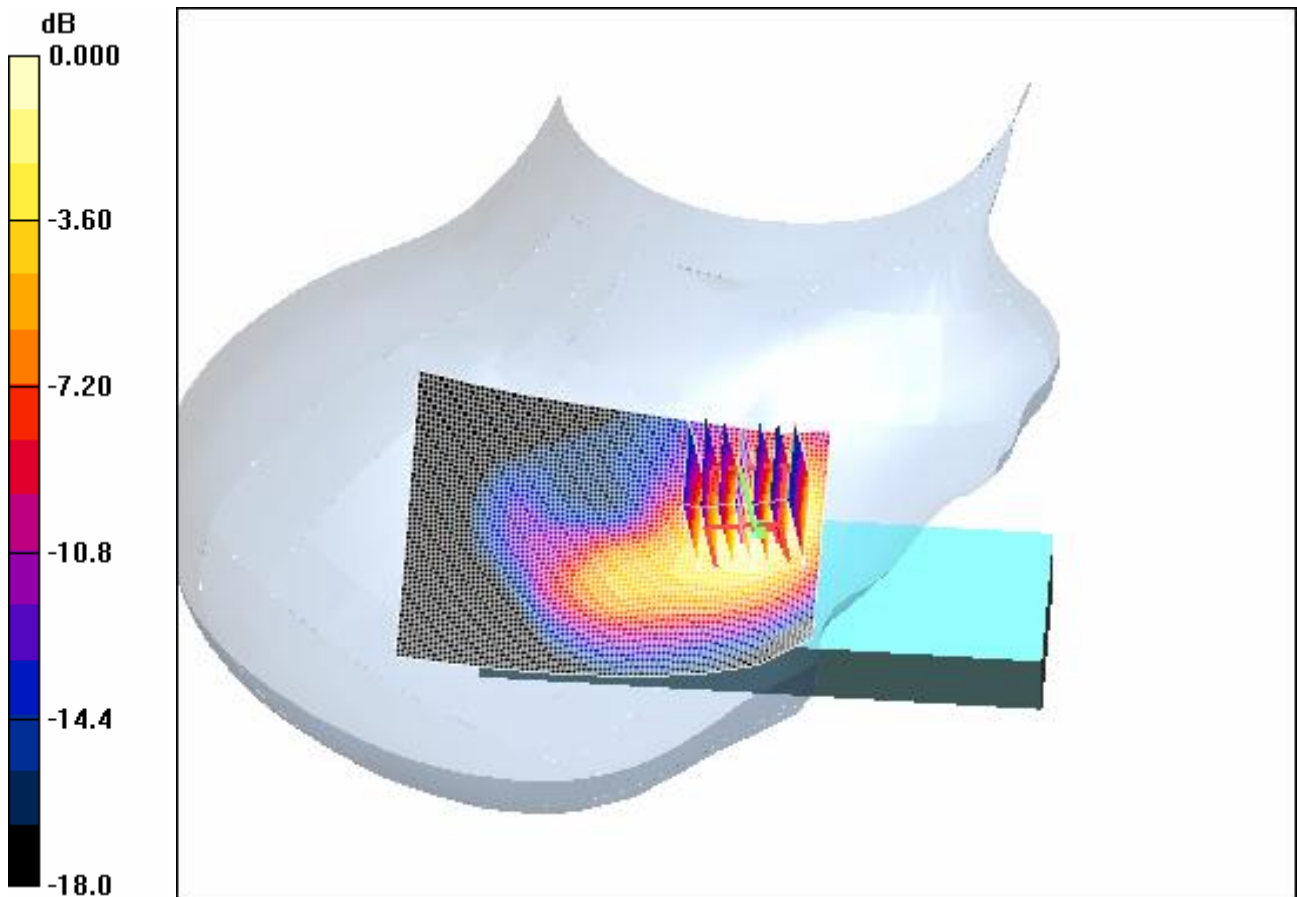

0 dB = 1.31mW/g

4.23 PCS1900-RightHandSide-Cheek-High-BYD

Date/Time: 2008-4-10 10:02:17

Test Laboratory: SGS-GSM

PCS1900-RightHandSide-Cheek-High-BYD

DUT: KJ005AE01; Type: Head; Serial: 011452000001826

Communication System: PCS1900-GSM Mode; Frequency: 1909.8 MHz; Duty Cycle: 1:8.3

Medium: HSL1900_Head Medium parameters used: $f = 1909.8$ MHz; $\sigma = 1.43$ mho/m; $\epsilon_r = 38.9$; $\rho = 1000$ kg/m³

Phantom section: Right Section

DASY4 Configuration:

- Probe: ES3DV3 - SN3088; ConvF(4.84, 4.84, 4.84); Calibrated: 2008-1-18
- Sensor-Surface: 4mm (Mechanical Surface Detection)
- Electronics: DAE3 Sn569; Calibrated: 2007-11-19
- Phantom: SAM 12; Type: SAM V4.0; Serial: TP-1283
- Measurement SW: DASY4, V4.7 Build 44; Postprocessing SW: SEMCAD, V1.8 Build 171

Cheek position - High BYD/Area Scan (61x81x1): Measurement grid: dx=15mm, dy=15mm

Maximum value of SAR (interpolated) = 1.17 mW/g

Cheek position - High BYD/Zoom Scan (7x7x7) (7x7x7)/Cube 0: Measurement grid: dx=5mm, dy=5mm, dz=5mm

Reference Value = 6.20 V/m; Power Drift = -0.033 dB

Peak SAR (extrapolated) = 1.66 W/kg

SAR(1 g) = 1 mW/g; SAR(10 g) = 0.561 mW/g

Maximum value of SAR (measured) = 1.12 mW/g

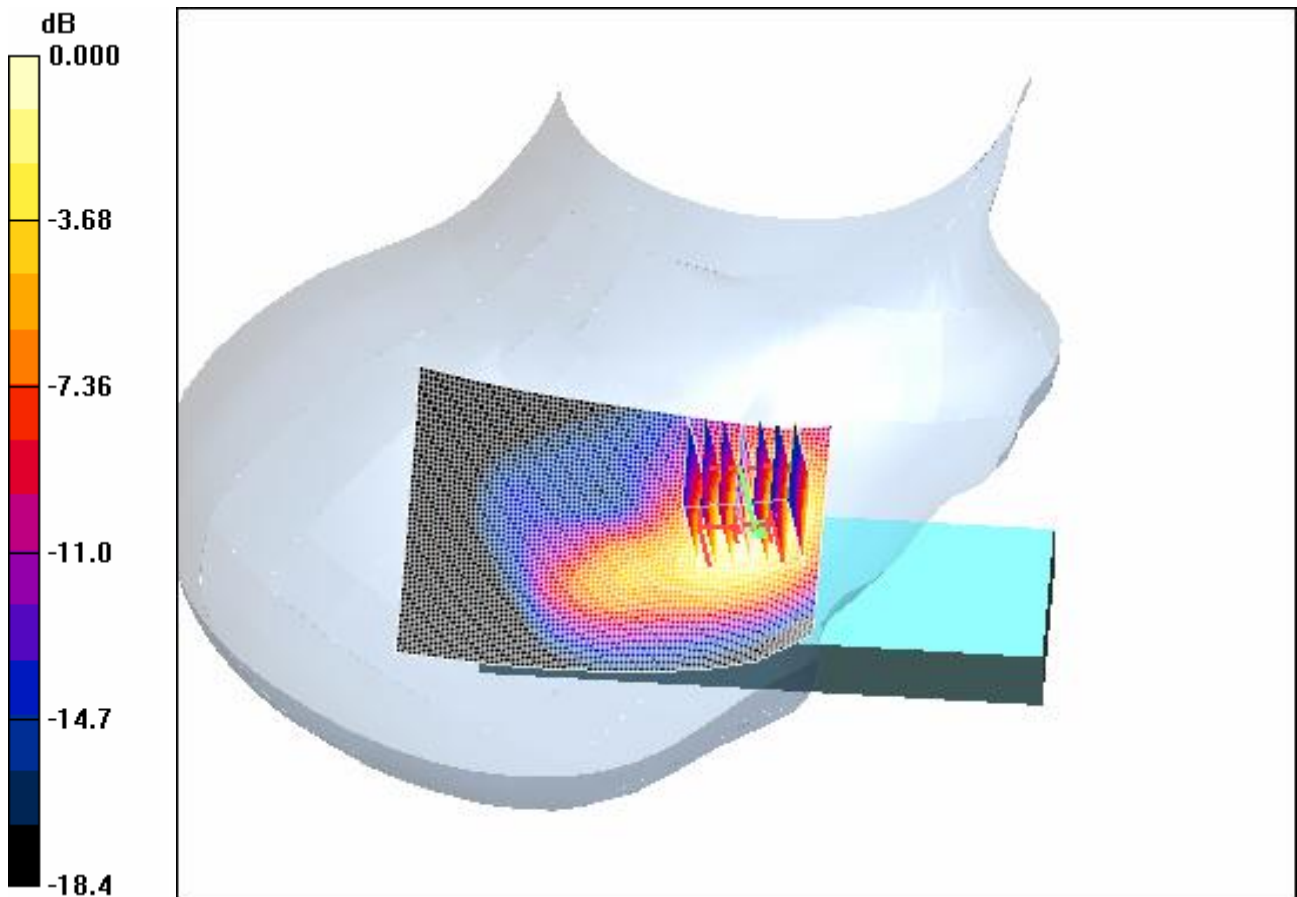

0 dB = 1.12mW/g

4.24 PCS1900-RightHandSide-Cheek-Middle-Coslight

Date/Time: 2008-4-10 13:42:57

Test Laboratory: SGS-GSM

PCS1900-RightHandSide-Cheek-Middle-Coslight

DUT: KJ005AE01; Type: Head; Serial: 011452000001826

Communication System: PCS1900-GSM Mode; Frequency: 1880 MHz; Duty Cycle: 1:8.3

Medium: HSL1900_Head Medium parameters used: $f = 1880$ MHz; $\sigma = 1.4$ mho/m; $\epsilon_r = 39$; $\rho = 1000$ kg/m³

Phantom section: Right Section

DASY4 Configuration:

- Probe: ES3DV3 - SN3088; ConvF(4.84, 4.84, 4.84); Calibrated: 2008-1-18
- Sensor-Surface: 4mm (Mechanical Surface Detection)
- Electronics: DAE3 Sn569; Calibrated: 2007-11-19
- Phantom: SAM 12; Type: SAM V4.0; Serial: TP-1283
- Measurement SW: DASY4, V4.7 Build 44; Postprocessing SW: SEMCAD, V1.8 Build 171

Cheek position - Middle Coslight/Area Scan (61x81x1): Measurement grid: dx=15mm, dy=15mm
Maximum value of SAR (interpolated) = 1.42 mW/g

Cheek position - Middle Coslight/Zoom Scan (7x7x7) (7x7x7)/Cube 0: Measurement grid:
dx=5mm, dy=5mm, dz=5mm

Reference Value = 7.78 V/m; Power Drift = 0.002 dB

Peak SAR (extrapolated) = 2.13 W/kg

SAR(1 g) = 1.26 mW/g; SAR(10 g) = 0.688 mW/g

Maximum value of SAR (measured) = 1.40 mW/g

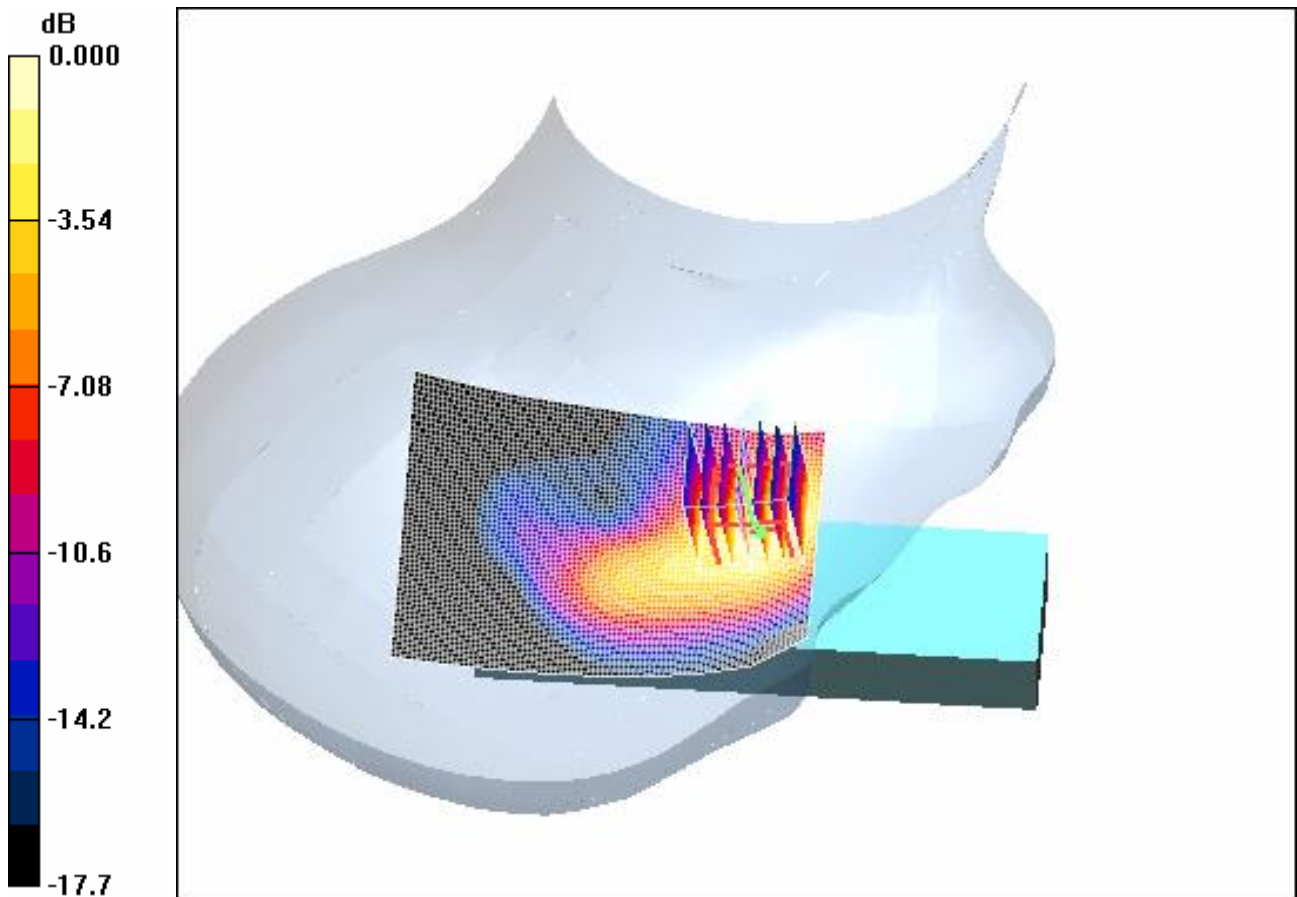

0 dB = 1.40mW/g

4.25 PCS1900-Body-Worn -Low-BYD-Headset CCA3010000E0

Date/Time: 2008-4-11 13:15:37

Test Laboratory: SGS-GSM

PCS1900-Body-Worn-Low-2.0cm-BYD-Headset CCA3010000E0

DUT: KJ005AE01; Type: Head; Serial: 011452000001826

Communication System: PCS1900-GSM Mode; Frequency: 1850.2 MHz; Duty Cycle: 1:8.3

Medium: HSL1900_Body Medium parameters used: $f = 1850.2$ MHz; $\sigma = 1.51$ mho/m; $\epsilon_r = 51.9$; $\rho = 1000$ kg/m³

Phantom section: Flat Section

DASY4 Configuration:

- Probe: ES3DV3 - SN3088; ConvF(4.6, 4.6, 4.6); Calibrated: 2008-1-18
- Sensor-Surface: 4mm (Mechanical Surface Detection)
- Electronics: DAE3 Sn569; Calibrated: 2007-11-19
- Phantom: SAM 12; Type: SAM V4.0; Serial: TP-1283
- Measurement SW: DASY4, V4.7 Build 44; Postprocessing SW: SEMCAD, V1.8 Build 171

Body Worn - Low BYD/Area Scan (51x91x1): Measurement grid: dx=15mm, dy=15mm

Maximum value of SAR (interpolated) = 0.605 mW/g

Body Worn - Low BYD/Zoom Scan (7x7x7)/Cube 0: Measurement grid: dx=5mm, dy=5mm,
dz=5mm

Reference Value = 9.75 V/m; Power Drift = -0.106 dB

Peak SAR (extrapolated) = 0.953 W/kg

SAR(1 g) = 0.532 mW/g; SAR(10 g) = 0.295 mW/g

Maximum value of SAR (measured) = 0.582 mW/g

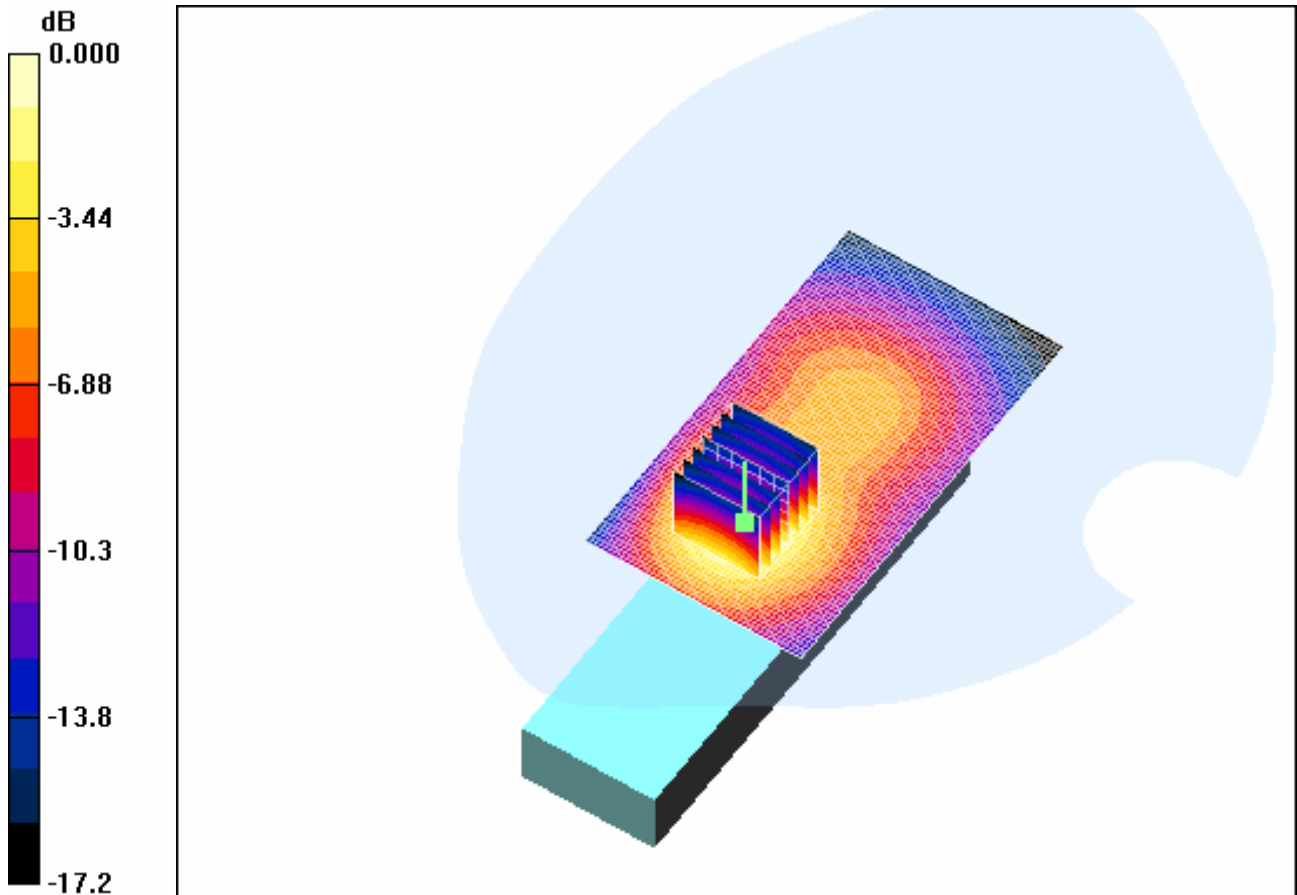

0 dB = 0.582mW/g

4.26 PCS1900-Body-Worn -Middle-BYD-Headset CCA3010000E0

Date/Time: 2008-4-11 10:45:28

Test Laboratory: SGS-GSM

PCS1900-Body-Worn-Middle-2.0cm-BYD-Headset CCA3010000E0

DUT: KJ005AE01; Type: Head; Serial: 011452000001826

Communication System: PCS1900-GSM Mode; Frequency: 1880 MHz; Duty Cycle: 1:8.3

Medium: HSL1900_Body Medium parameters used: $f = 1880$ MHz; $\sigma = 1.54$ mho/m; $\epsilon_r = 51.7$; $\rho = 1000$ kg/m³

Phantom section: Flat Section

DASY4 Configuration:

- Probe: ES3DV3 - SN3088; ConvF(4.6, 4.6, 4.6); Calibrated: 2008-1-18
- Sensor-Surface: 4mm (Mechanical Surface Detection)
- Electronics: DAE3 Sn569; Calibrated: 2007-11-19
- Phantom: SAM 12; Type: SAM V4.0; Serial: TP-1283
- Measurement SW: DASY4, V4.7 Build 44; Postprocessing SW: SEMCAD, V1.8 Build 171

Body Worn - Middle BYD/Area Scan (51x91x1): Measurement grid: dx=15mm, dy=15mm
Maximum value of SAR (interpolated) = 0.511 mW/g

Body Worn - Middle BYD/Zoom Scan (7x7x7)/Cube 0: Measurement grid: dx=5mm, dy=5mm,
dz=5mm

Reference Value = 11.2 V/m; Power Drift = -0.043 dB

Peak SAR (extrapolated) = 0.817 W/kg

SAR(1 g) = 0.453 mW/g; SAR(10 g) = 0.253 mW/g

Maximum value of SAR (measured) = 0.487 mW/g

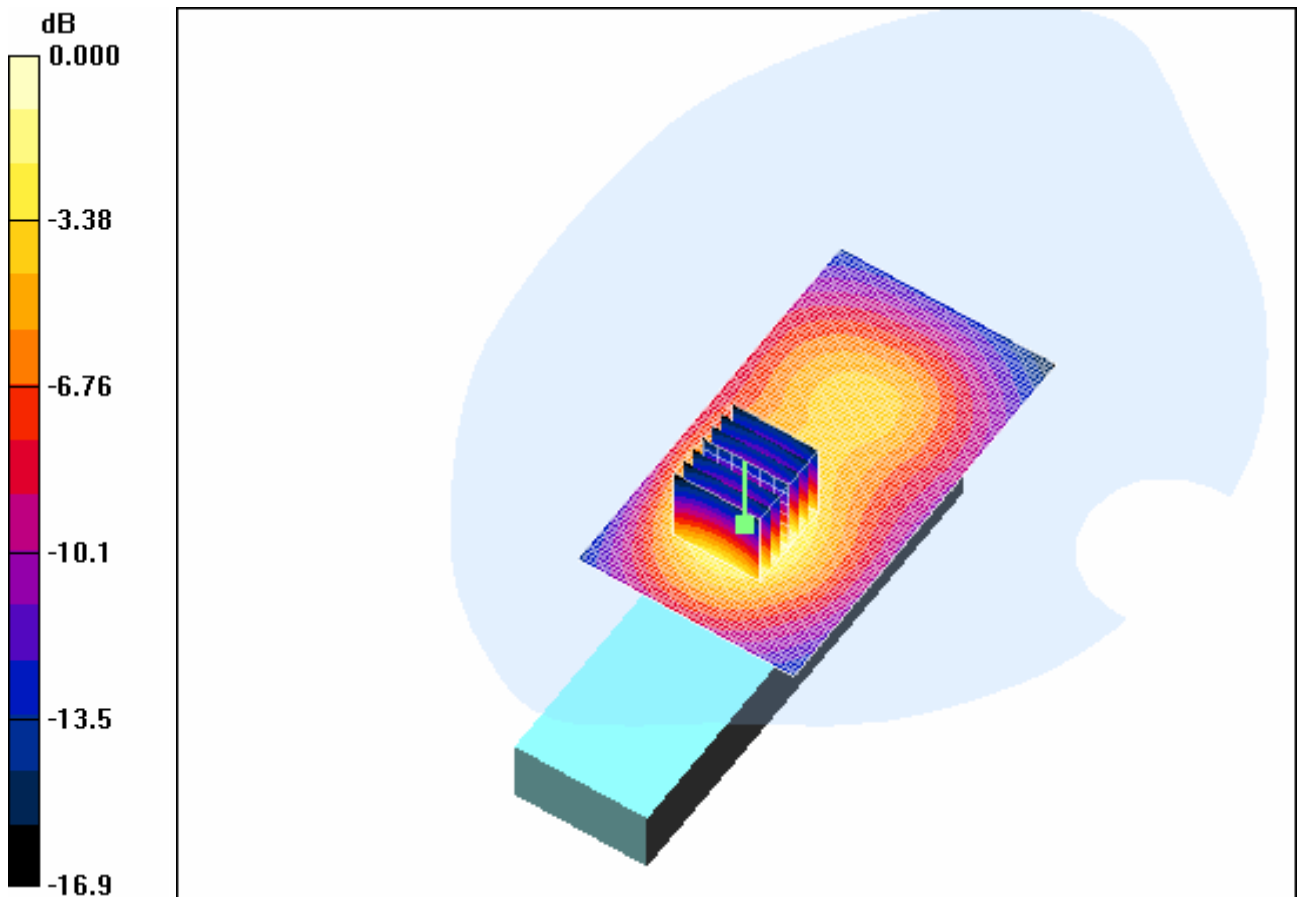

0 dB = 0.487mW/g

4.27 PCS1900-Body-Worn -High-BYD-Headset CCA3010000E0

Date/Time: 2008-4-11 11:04:57

Test Laboratory: SGS-GSM

PCS1900-Body-Worn-High-2.0cm-BYD-Headset CCA3010000E0

DUT: KJ005AE01; Type: Head; Serial: 011452000001826

Communication System: PCS1900-GSM Mode; Frequency: 1909.8 MHz; Duty Cycle: 1:8.3

Medium: HSL1900_Body Medium parameters used: $f = 1909.8$ MHz; $\sigma = 1.57$ mho/m; $\epsilon_r = 51.6$; $\rho = 1000$ kg/m³

Phantom section: Flat Section

DASY4 Configuration:

- Probe: ES3DV3 - SN3088; ConvF(4.6, 4.6, 4.6); Calibrated: 2008-1-18
- Sensor-Surface: 4mm (Mechanical Surface Detection)
- Electronics: DAE3 Sn569; Calibrated: 2007-11-19
- Phantom: SAM 12; Type: SAM V4.0; Serial: TP-1283
- Measurement SW: DASY4, V4.7 Build 44; Postprocessing SW: SEMCAD, V1.8 Build 171

Body Worn -High BYD/Area Scan (51x91x1): Measurement grid: dx=15mm, dy=15mm

Maximum value of SAR (interpolated) = 0.449 mW/g

Body Worn -High BYD/Zoom Scan (7x7x7)/Cube 0: Measurement grid: dx=5mm, dy=5mm,
dz=5mm

Reference Value = 11.4 V/m; Power Drift = -0.035 dB

Peak SAR (extrapolated) = 0.704 W/kg

SAR(1 g) = 0.393 mW/g; SAR(10 g) = 0.220 mW/g

Maximum value of SAR (measured) = 0.425 mW/g

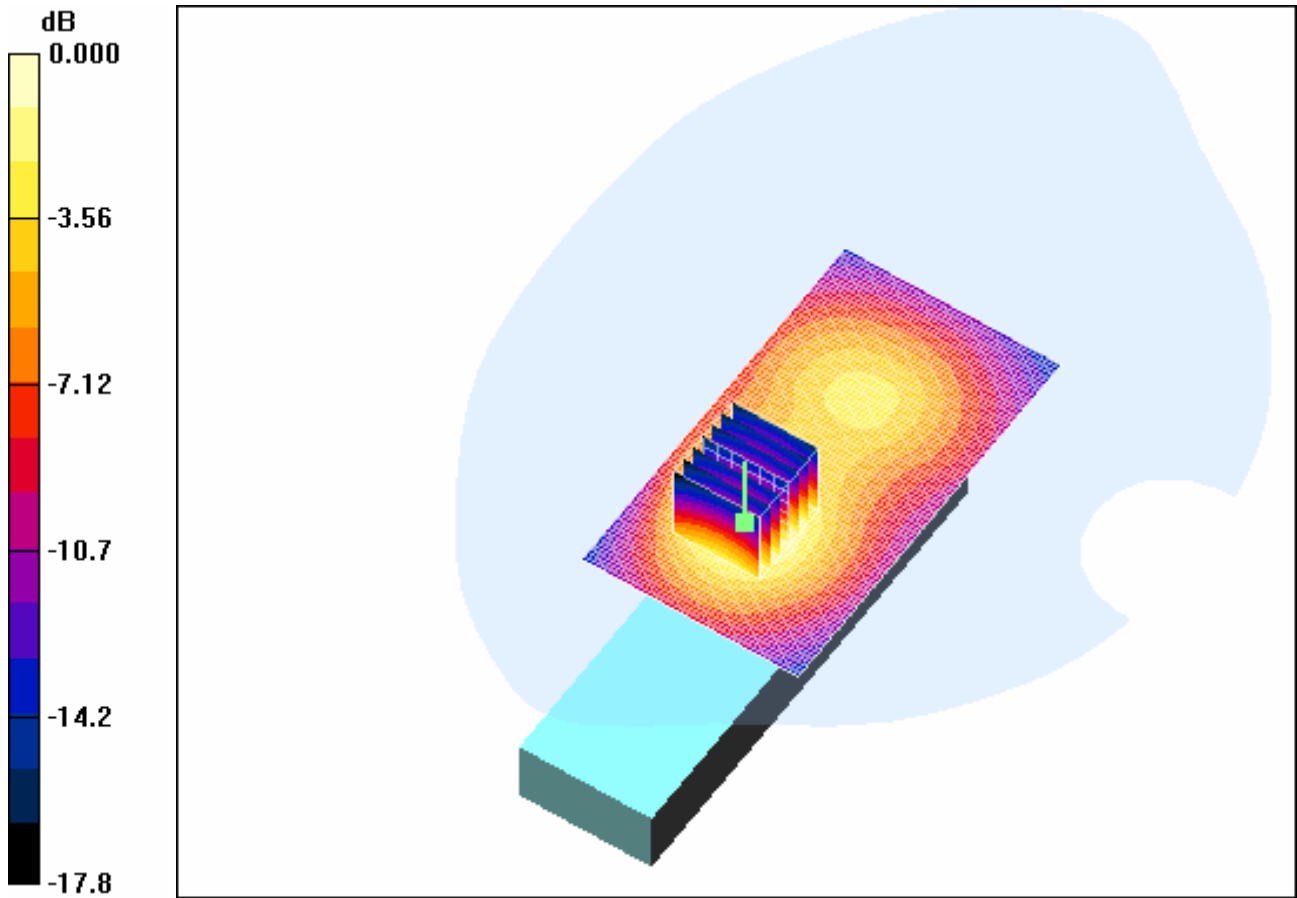

0 dB = 0.425mW/g

4.28 PCS1900-Body-Worn -Low-Coslight-Headset CCA3010000E0

Date/Time: 2008-4-11 10:23:20

Test Laboratory: SGS-GSM

PCS1900-Body-Worn-Low-2.0cm-Colisght-Headset CCA3010000E0

DUT: KJ005AE01; Type: Head; Serial: 011452000001826

Communication System: PCS1900-GSM Mode; Frequency: 1850.2 MHz;Duty Cycle: 1:8.3

Medium: HSL1900_Body Medium parameters used: $f = 1850.2$ MHz; $\sigma = 1.51$ mho/m; $\epsilon_r = 51.9$; $\rho =$

1000 kg/m³

Phantom section: Flat Section

DASY4 Configuration:

- Probe: ES3DV3 - SN3088; ConvF(4.6, 4.6, 4.6); Calibrated: 2008-1-18
- Sensor-Surface: 4mm (Mechanical Surface Detection)
- Electronics: DAE3 Sn569; Calibrated: 2007-11-19
- Phantom: SAM 12; Type: SAM V4.0; Serial: TP-1283
- Measurement SW: DASY4, V4.7 Build 44; Postprocessing SW: SEMCAD, V1.8 Build 171

Body Worn - Low Coslight/Area Scan (51x91x1): Measurement grid: dx=15mm, dy=15mm

Maximum value of SAR (interpolated) = 0.561 mW/g

Body Worn - Low Coslight/Zoom Scan (7x7x7)/Cube 0: Measurement grid: dx=5mm, dy=5mm, dz=5mm

Reference Value = 10.9 V/m; Power Drift = -0.153 dB

Peak SAR (extrapolated) = 0.867 W/kg

SAR(1 g) = 0.491 mW/g; SAR(10 g) = 0.274 mW/g

Maximum value of SAR (measured) = 0.536 mW/g

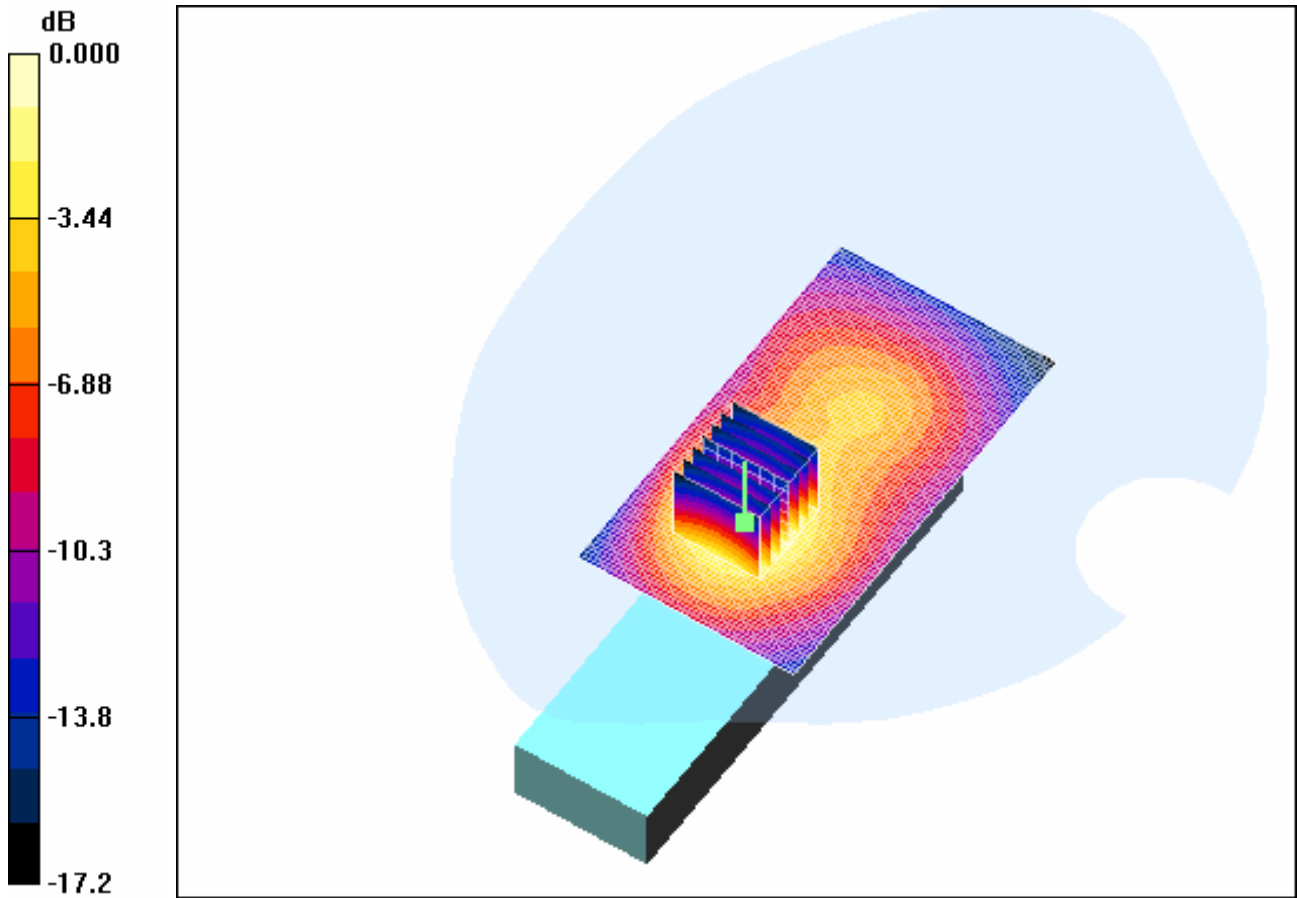

0 dB = 0.536mW/g

Additional Tests

4.29 GSM850-Flat Phantom- Head-Middle-BYD

Date/Time: 2008-7-25 9:15:26

Test Laboratory: SGS-GSM

GSM850-Head-Worn-Mid-BYD-0.5cm

DUT: KJ005AA02; Type: Head; Serial: 01146700000220-2

Communication System: GSM850-GSM Mode; Frequency: 836.4 MHz; Duty Cycle: 1:8.3

Medium: HSL 850_Body Medium parameters used: $f = 836.4$ MHz; $\sigma = 0.98$ mho/m; $\epsilon_r = 53.1$; $\rho = 1000$ kg/m³

Phantom section: Flat Section

DASY4 Configuration:

- Probe: ES3DV3 - SN3088; ConvF(5.81, 5.81, 5.81); Calibrated: 2008-1-18
- Sensor-Surface: 4mm (Mechanical Surface Detection)
- Electronics: DAE3 Sn569; Calibrated: 2007-11-19
- Phantom: SAM 12; Type: SAM V4.0; Serial: TP-1283
- Measurement SW: DASY4, V4.7 Build 44; Postprocessing SW: SEMCAD, V1.8 Build 171

Body Worn - Middle BYD/Area Scan (81x131x1): Measurement grid: dx=15mm, dy=15mm

Maximum value of SAR (interpolated) = 0.647 mW/g

Body Worn - Middle BYD/Zoom Scan (7x7x7)/Cube 0: Measurement grid: dx=5mm, dy=5mm, dz=5mm

Reference Value = 3.99 V/m; Power Drift = 0.219 dB

Peak SAR (extrapolated) = 0.848 W/kg

SAR(1 g) = 0.605 mW/g; SAR(10 g) = 0.413 mW/g

Maximum value of SAR (measured) = 0.645 mW/g

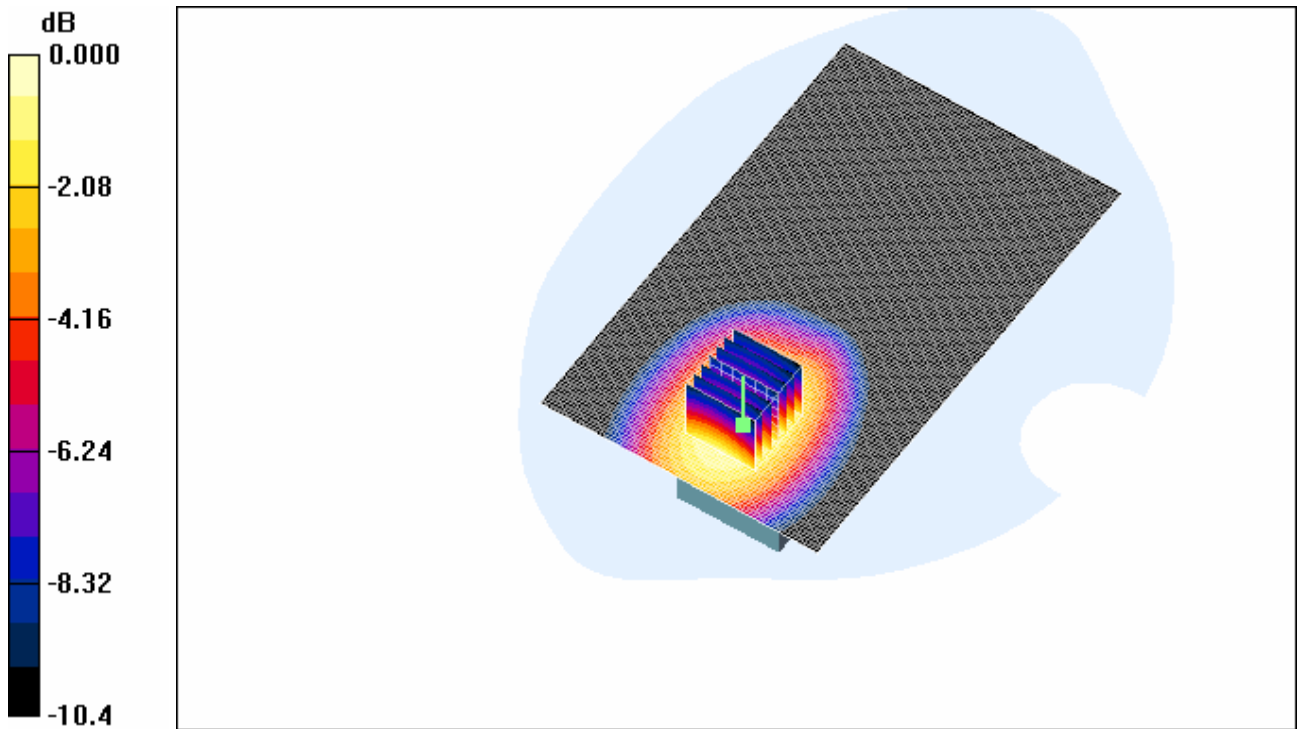

0 dB = 0.645mW/g

4.30 GSM850-Flat Phantom- Head-Low-BYD

Date/Time: 2008-7-25 9:45:28

Test Laboratory: SGS-GSM

GSM850-Head-Worn-Low-BYD-0.5cm

DUT: KJ005AA02; Type: Head; Serial: 01146700000220-2

Communication System: GSM850-GSM Mode; Frequency: 824.2 MHz; Duty Cycle: 1:8.3

Medium: HSL 850_Body Medium parameters used: $f = 824.2$ MHz; $\sigma = 0.964$ mho/m; $\epsilon_r = 53.2$; $\rho = 1000$ kg/m³

Phantom section: Flat Section

DASY4 Configuration:

- Probe: ES3DV3 - SN3088; ConvF(5.81, 5.81, 5.81); Calibrated: 2008-1-18

- Sensor-Surface: 4mm (Mechanical Surface Detection)
- Electronics: DAE3 Sn569; Calibrated: 2007-11-19
- Phantom: SAM 12; Type: SAM V4.0; Serial: TP-1283
- Measurement SW: DASY4, V4.7 Build 44; Postprocessing SW: SEMCAD, V1.8 Build 171

Body Worn - Low BYD/Area Scan (81x131x1): Measurement grid: dx=15mm, dy=15mm
Maximum value of SAR (interpolated) = 0.544 mW/g

Body Worn - Low BYD/Zoom Scan (7x7x7) (7x7x7)/Cube 0: Measurement grid: dx=5mm, dy=5mm, dz=5mm

Reference Value = 3.79 V/m; Power Drift = 0.045 dB

Peak SAR (extrapolated) = 0.704 W/kg

SAR(1 g) = 0.508 mW/g; SAR(10 g) = 0.350 mW/g

Maximum value of SAR (measured) = 0.539 mW/g

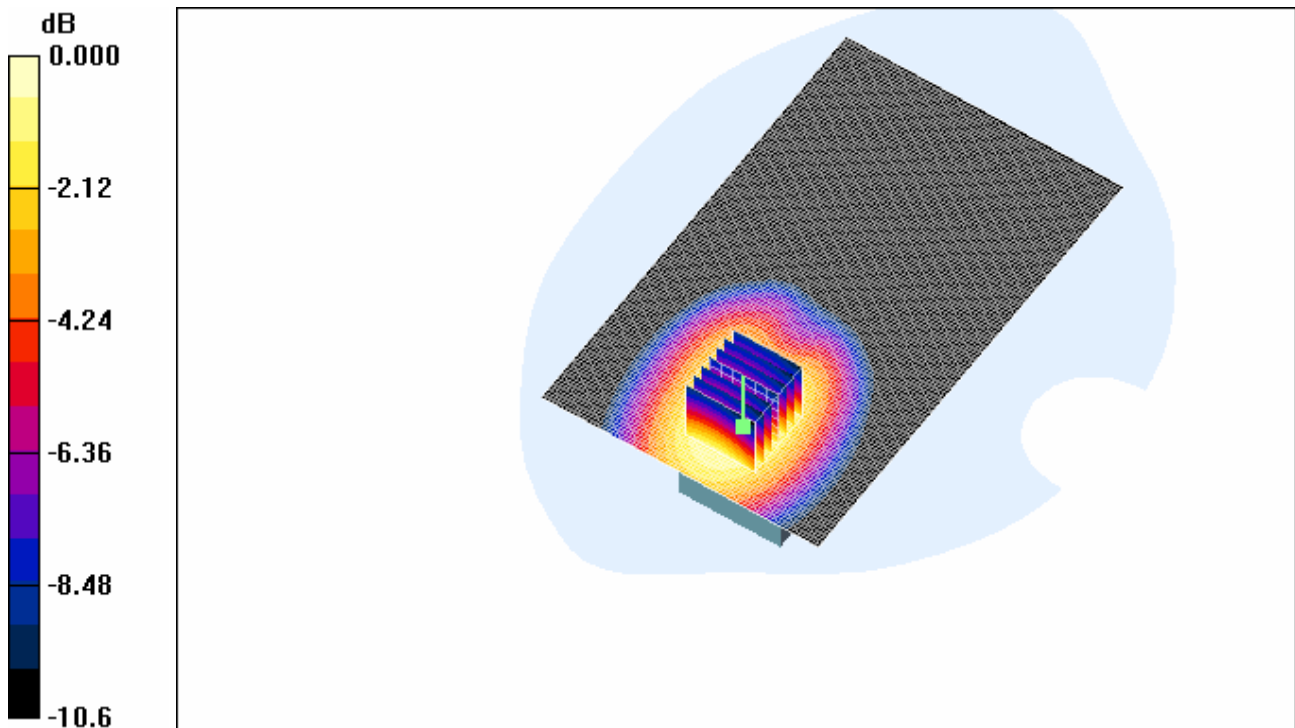

0 dB = 0.539mW/g

4.31 GSM850-Flat Phantom- Head-High-BYD

Date/Time: 2008-7-25 10:13:28

Test Laboratory: SGS-GSM

GSM850-Head-Worn-High-BYD-0.5cm

DUT: KJ005AA02; Type: Head; Serial: 01146700000220-2

Communication System: GSM850-GSM Mode; Frequency: 848.8 MHz; Duty Cycle: 1:8.3

Medium: HSL 850_Body Medium parameters used: $f = 848.8$ MHz; $\sigma = 0.994$ mho/m; $\epsilon_r = 53.1$; $\rho = 1000$ kg/m³

Phantom section: Flat Section

DASY4 Configuration:

- Probe: ES3DV3 - SN3088; ConvF(5.81, 5.81, 5.81); Calibrated: 2008-1-18
- Sensor-Surface: 4mm (Mechanical Surface Detection)
- Electronics: DAE3 Sn569; Calibrated: 2007-11-19
- Phantom: SAM 12; Type: SAM V4.0; Serial: TP-1283
- Measurement SW: DASY4, V4.7 Build 44; Postprocessing SW: SEMCAD, V1.8 Build 171

Body Worn - High BYD/Area Scan (81x131x1): Measurement grid: dx=15mm, dy=15mm

Maximum value of SAR (interpolated) = 0.899 mW/g

Body Worn - High BYD/Zoom Scan (7x7x7) (7x7x7)/Cube 0: Measurement grid: dx=5mm, dy=5mm, dz=5mm

Reference Value = 5.37 V/m; Power Drift = -0.037 dB

Peak SAR (extrapolated) = 1.15 W/kg

SAR(1 g) = 0.822 mW/g; SAR(10 g) = 0.557 mW/g

Maximum value of SAR (measured) = 0.884 mW/g

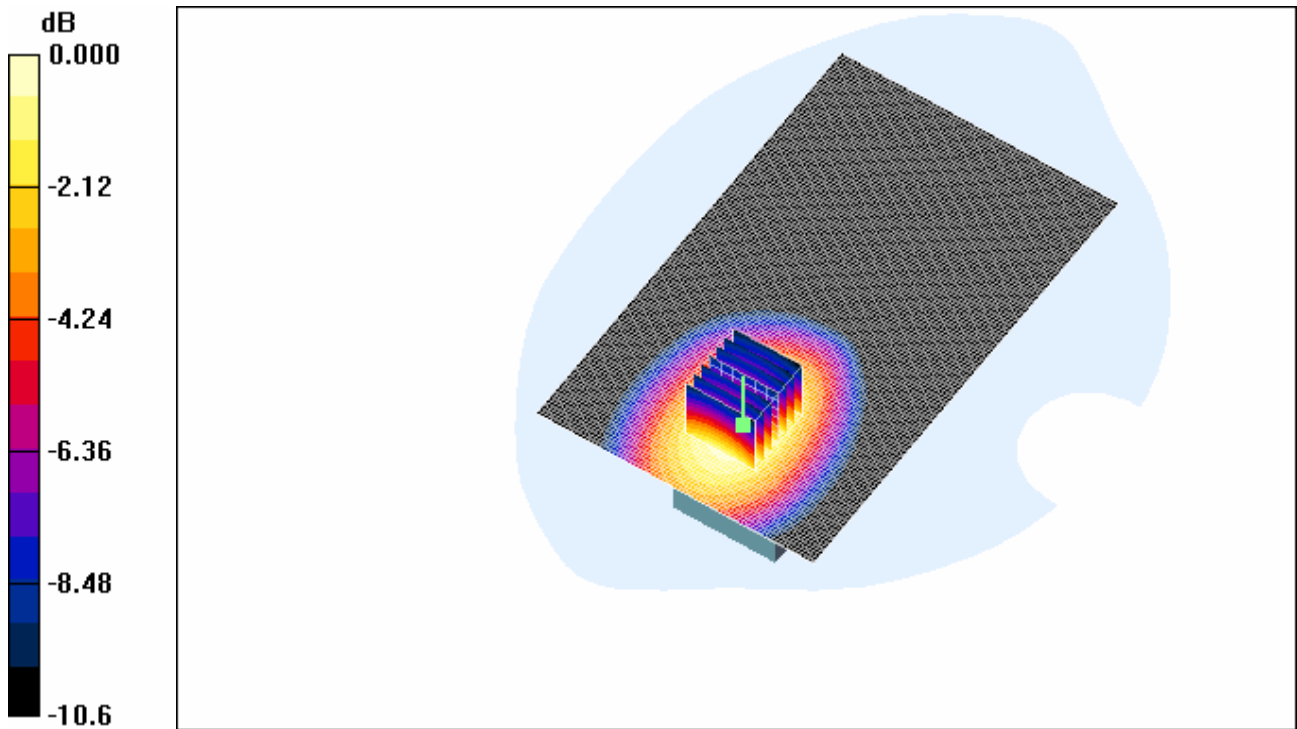

0 dB = 0.884mW/g

4.32 GSM850-Flat Phantom- Head-High-Coslight

Date/Time: 2008-7-25 10:42:08

Test Laboratory: SGS-GSM

GSM850-Head-Worn-High-Cos-0.5cm

DUT: KJ005AA02; Type: Head; Serial: 01146700000220-2

Communication System: GSM850-GSM Mode; Frequency: 848.8 MHz; Duty Cycle: 1:8.3

Medium: HSL 850_Body Medium parameters used: $f = 848.8$ MHz; $\sigma = 0.994$ mho/m; $\epsilon_r = 53.1$; $\rho = 1000$ kg/m³

Phantom section: Flat Section

DASY4 Configuration:

- Probe: ES3DV3 - SN3088; ConvF(5.81, 5.81, 5.81); Calibrated: 2008-1-18

- Sensor-Surface: 4mm (Mechanical Surface Detection)
- Electronics: DAE3 Sn569; Calibrated: 2007-11-19
- Phantom: SAM 12; Type: SAM V4.0; Serial: TP-1283
- Measurement SW: DASY4, V4.7 Build 44; Postprocessing SW: SEMCAD, V1.8 Build 171

Body Worn - HighCoslight/Area Scan (81x131x1): Measurement grid: dx=15mm, dy=15mm
Maximum value of SAR (interpolated) = 0.906 mW/g

Body Worn - HighCoslight/Zoom Scan (7x7x7) (7x7x7)/Cube 0: Measurement grid: dx=5mm, dy=5mm, dz=5mm

Reference Value = 5.09 V/m; Power Drift = -0.033 dB

Peak SAR (extrapolated) = 1.18 W/kg

SAR(1 g) = 0.833 mW/g; SAR(10 g) = 0.564 mW/g

Maximum value of SAR (measured) = 0.890 mW/g

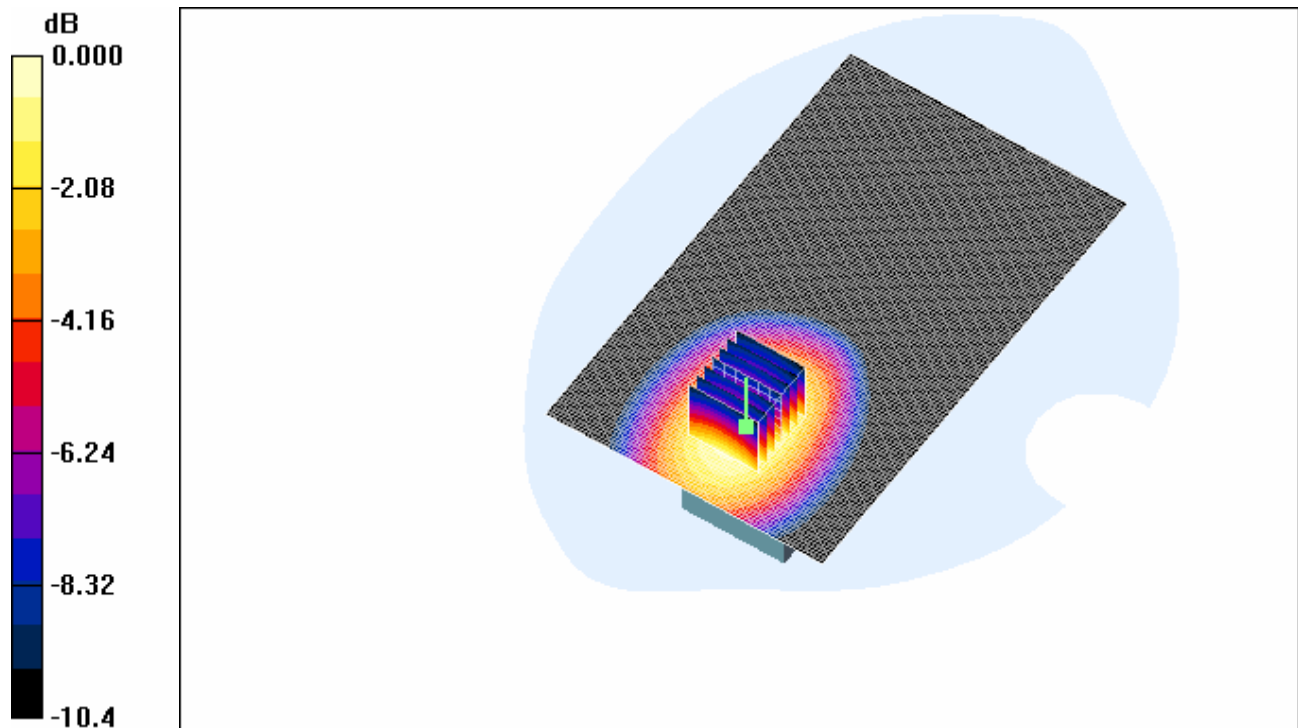

0 dB = 0.890mW/g

4.33 PCS1900-Flat Phantom- Head-Middle-BYD

Date/Time: 2008-7-24 21:02:35

Test Laboratory: SGS-GSM

PCS1900-Head-Worn-Mid-BYD-0.5cm

DUT: KJ005AA02; Type: Head; Serial: 01146700000220-2

Communication System: PCS1900-GSM Mode; Frequency: 1880 MHz; Duty Cycle: 1:8.3

Medium: 1900-Head Medium parameters used: $f = 1880$ MHz; $\sigma = 1.37$ mho/m; $\epsilon_r = 41.8$; $\rho = 1000$ kg/m³

Phantom section: Flat Section

DASY4 Configuration:

- Probe: ES3DV3 - SN3088; ConvF(4.84, 4.84, 4.84); Calibrated: 2008-1-18
- Sensor-Surface: 4mm (Mechanical Surface Detection)
- Electronics: DAE3 Sn569; Calibrated: 2007-11-19
- Phantom: SAM 12; Type: SAM V4.0; Serial: TP-1283
- Measurement SW: DASY4, V4.7 Build 44; Postprocessing SW: SEMCAD, V1.8 Build 171

Body Worn - Middle BYD/Area Scan (81x131x1): Measurement grid: dx=15mm, dy=15mm
Maximum value of SAR (interpolated) = 0.414 mW/g

Body Worn - Middle BYD/Zoom Scan (7x7x7)/Cube 0: Measurement grid: dx=5mm, dy=5mm,
dz=5mm

Reference Value = 4.10 V/m; Power Drift = -0.010 dB

Peak SAR (extrapolated) = 0.656 W/kg

SAR(1 g) = 0.374 mW/g; SAR(10 g) = 0.203 mW/g

Maximum value of SAR (measured) = 0.416 mW/g

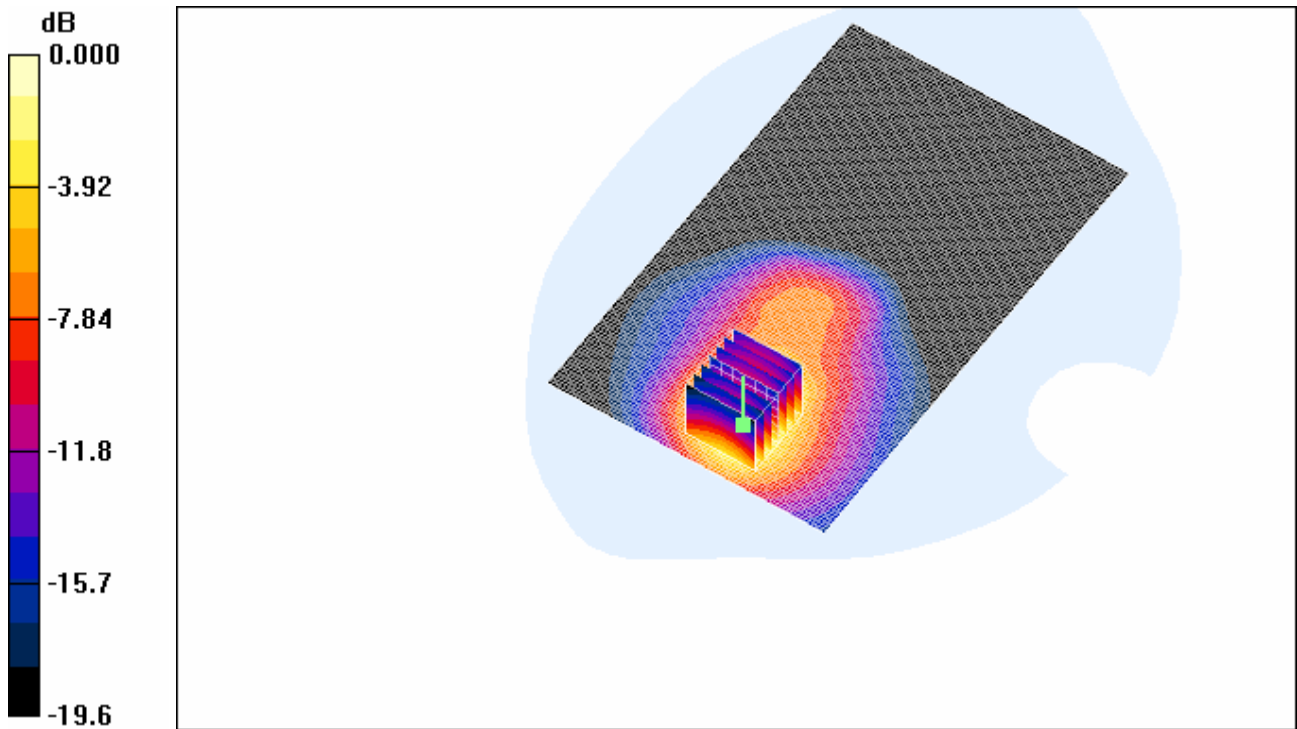

0 dB = 0.416mW/g

4.34 PCS1900-Flat Phantom- Head-Low-BYD

Date/Time: 2008-7-24 21:34:43

Test Laboratory: SGS-GSM

PCS1900-Head-Worn-Low-BYD-0.5cm

DUT: KJ005AA02; Type: Head; Serial: 01146700000220-2

Communication System: PCS1900-GSM Mode; Frequency: 1850.2 MHz; Duty Cycle: 1:8.3

Medium: 1900-Head Medium parameters used: $f = 1850.2$ MHz; $\sigma = 1.34$ mho/m; $\epsilon_r = 41.5$; $\rho = 1000$ kg/m³

Phantom section: Flat Section

DASY4 Configuration:

- Probe: ES3DV3 - SN3088; ConvF(4.84, 4.84, 4.84); Calibrated: 2008-1-18

- Sensor-Surface: 4mm (Mechanical Surface Detection)
- Electronics: DAE3 Sn569; Calibrated: 2007-11-19
- Phantom: SAM 12; Type: SAM V4.0; Serial: TP-1283
- Measurement SW: DASY4, V4.7 Build 44; Postprocessing SW: SEMCAD, V1.8 Build 171

Body Worn - Low BYD/Area Scan (81x131x1): Measurement grid: dx=15mm, dy=15mm
Maximum value of SAR (interpolated) = 0.493 mW/g

Body Worn - Low BYD/Zoom Scan (7x7x7)/Cube 0: Measurement grid: dx=5mm, dy=5mm,
dz=5mm

Reference Value = 3.99 V/m; Power Drift = 0.105 dB

Peak SAR (extrapolated) = 0.769 W/kg

SAR(1 g) = 0.445 mW/g; SAR(10 g) = 0.245 mW/g

Maximum value of SAR (measured) = 0.495 mW/g

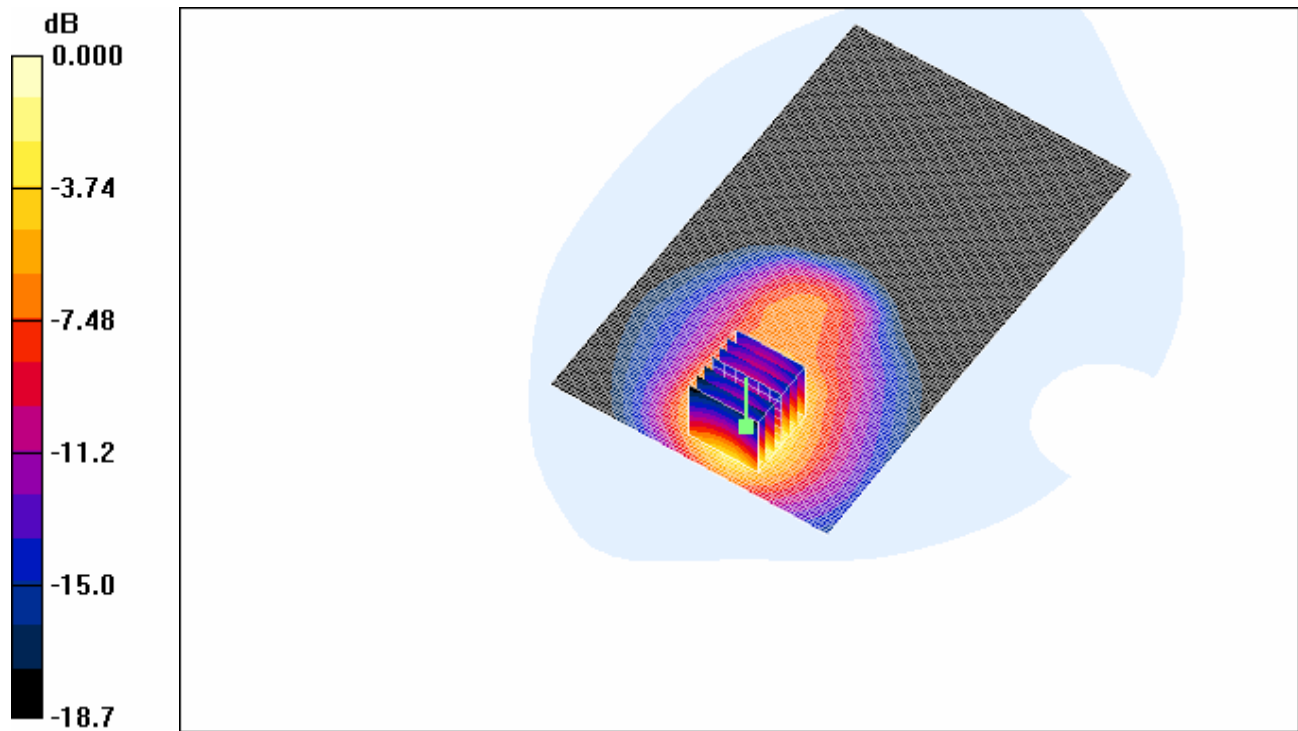

0 dB = 0.495mW/g

4.35 PCS1900-Flat Phantom- Head-High-BYD

Date/Time: 2008-7-24 22:07:03

Test Laboratory: SGS-GSM

PCS1900-Head-Worn-High-BYD-0.5cm

DUT: KJ005AA02; Type: Head; Serial: 01146700000220-2

Communication System: PCS1900-GSM Mode; Frequency: 1909.8 MHz; Duty Cycle: 1:8.3

Medium: 1900-Head Medium parameters used: $f = 1909.8$ MHz; $\sigma = 1.39$ mho/m; $\epsilon_r = 41.1$; $\rho = 1000$ kg/m³

Phantom section: Flat Section

DASY4 Configuration:

- Probe: ES3DV3 - SN3088; ConvF(4.84, 4.84, 4.84); Calibrated: 2008-1-18
- Sensor-Surface: 4mm (Mechanical Surface Detection)
- Electronics: DAE3 Sn569; Calibrated: 2007-11-19
- Phantom: SAM 12; Type: SAM V4.0; Serial: TP-1283
- Measurement SW: DASY4, V4.7 Build 44; Postprocessing SW: SEMCAD, V1.8 Build 171

Body Worn -High BYD/Area Scan (81x131x1): Measurement grid: dx=15mm, dy=15mm

Maximum value of SAR (interpolated) = 0.378 mW/g

Body Worn -High BYD/Zoom Scan (7x7x7)/Cube 0: Measurement grid: dx=5mm, dy=5mm, dz=5mm

Reference Value = 4.48 V/m; Power Drift = 0.082 dB

Peak SAR (extrapolated) = 0.593 W/kg

SAR(1 g) = 0.339 mW/g; SAR(10 g) = 0.183 mW/g

Maximum value of SAR (measured) = 0.376 mW/g

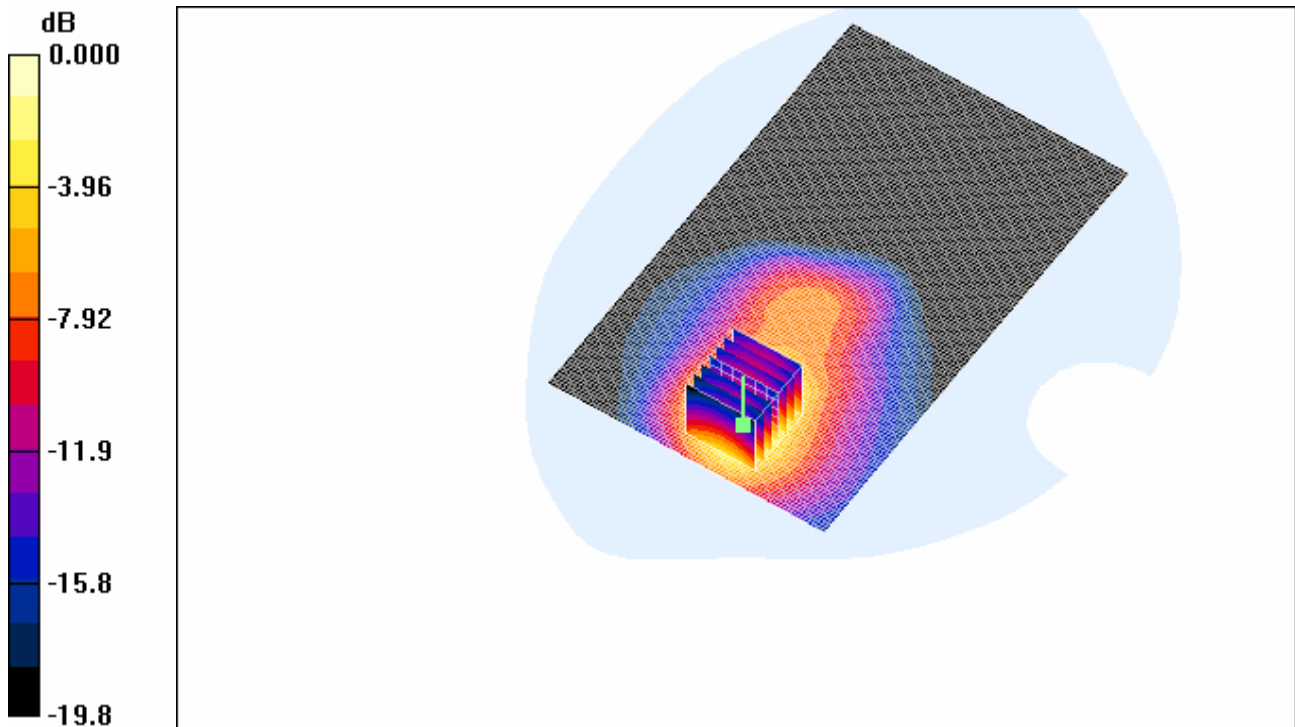

0 dB = 0.376mW/g

4.36 PCS1900-Flat Phantom- Head-Low-Coslight

Date/Time: 2008-7-24 22:33:12

Test Laboratory: SGS-GSM

PCS1900-Head-Worn-Low-Cos-0.5cm

DUT: KJ005AA02; Type: Head; Serial: 01146700000220-2

Communication System: PCS1900-GSM Mode; Frequency: 1850.2 MHz; Duty Cycle: 1:8.3

Medium: 1900-Head Medium parameters used: $f = 1850.2$ MHz; $\sigma = 1.34$ mho/m; $\epsilon_r = 41.5$; $\rho = 1000$ kg/m³

Phantom section: Flat Section

DASY4 Configuration:

- Probe: ES3DV3 - SN3088; ConvF(4.84, 4.84, 4.84); Calibrated: 2008-1-18

- Sensor-Surface: 4mm (Mechanical Surface Detection)
- Electronics: DAE3 Sn569; Calibrated: 2007-11-19
- Phantom: SAM 12; Type: SAM V4.0; Serial: TP-1283
- Measurement SW: DASY4, V4.7 Build 44; Postprocessing SW: SEMCAD, V1.8 Build 171

Body Worn - Low Coslight/Area Scan (81x131x1): Measurement grid: dx=15mm, dy=15mm

Maximum value of SAR (interpolated) = 0.496 mW/g

Body Worn - Low Coslight/Zoom Scan (7x7x7)/Cube 0: Measurement grid: dx=5mm, dy=5mm, dz=5mm

Reference Value = 5.01 V/m; Power Drift = 0.067 dB

Peak SAR (extrapolated) = 0.801 W/kg

SAR(1 g) = 0.459 mW/g; SAR(10 g) = 0.250 mW/g

Maximum value of SAR (measured) = 0.510 mW/g

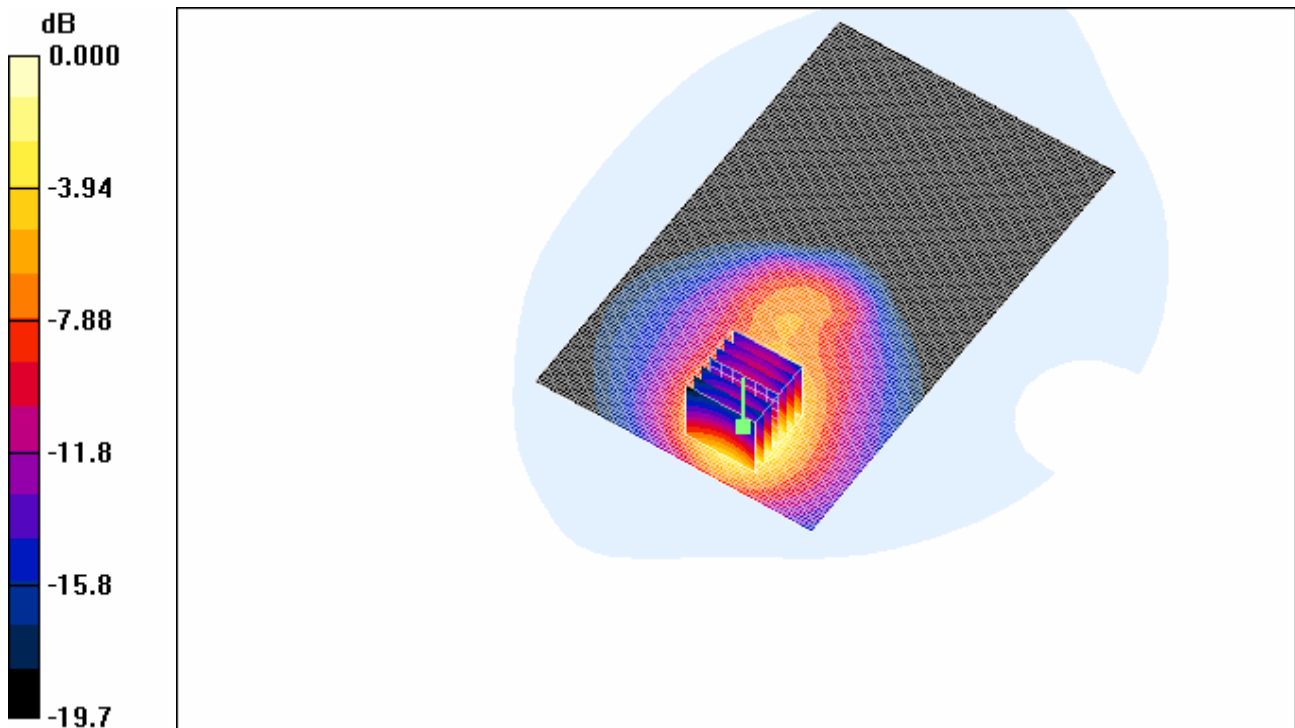

0 dB = 0.510mW/g

Appendix

1. Photographs of Test Setup

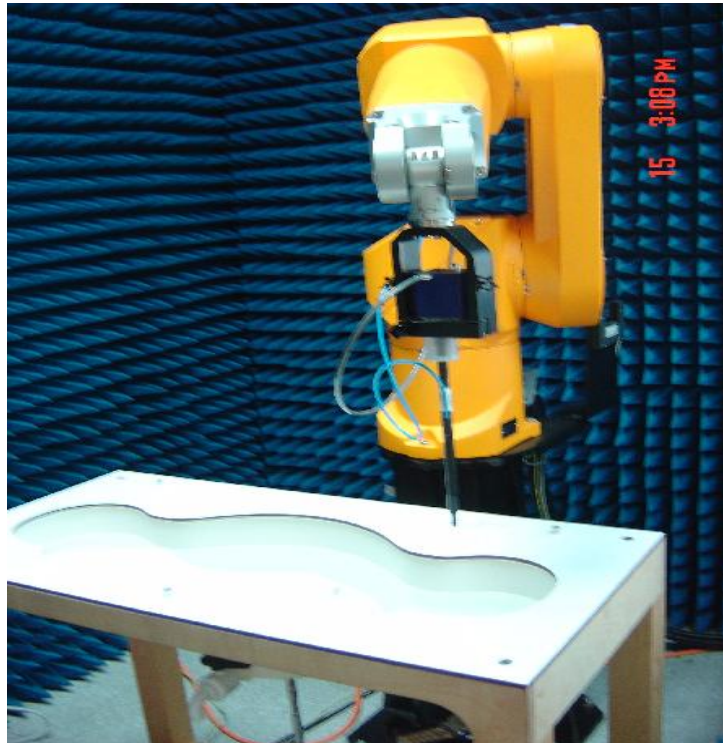

Fig.1 Photograph of the SAR measurement System

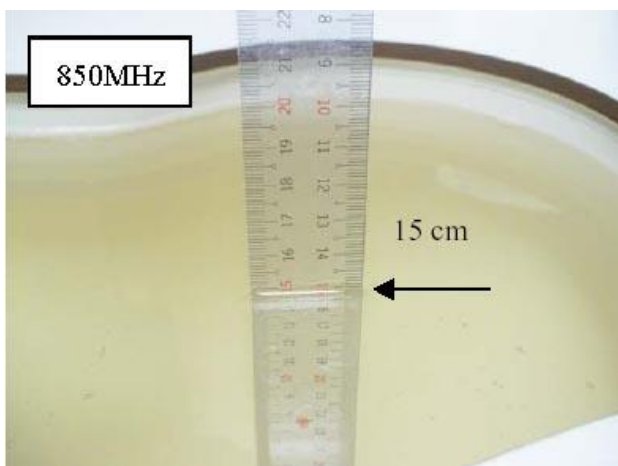

Fig.2 Photograph of the Tissue Simulant Fluid Liquid depth 15cm for Left-Head Side

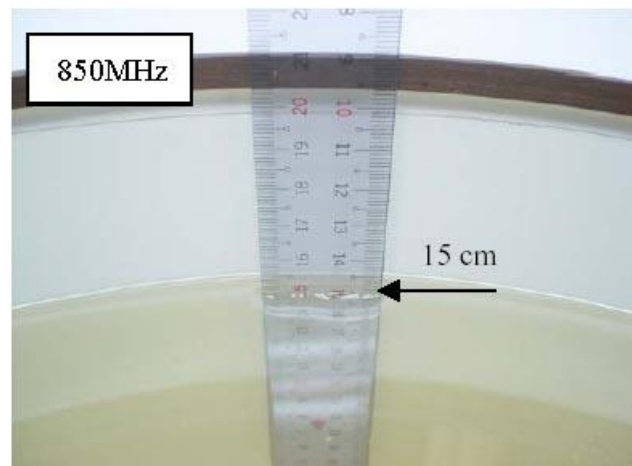

Fig.3 Photograph of the Tissue Simulant Liquid depth 15cm for Body-Worn

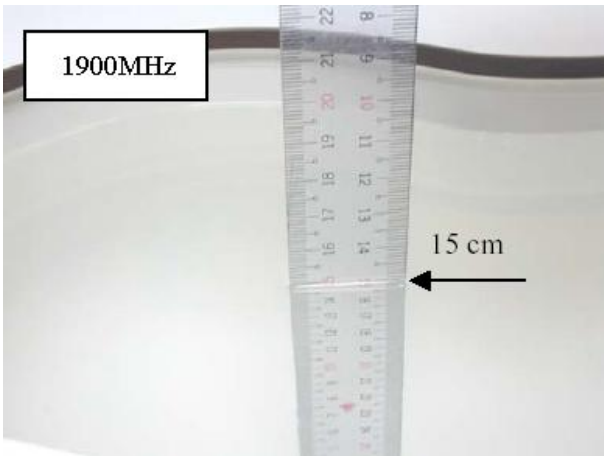

Fig.4 Photograph of the Tissue Simulant Fluid Liquid depth 15cm for Right-Head Side

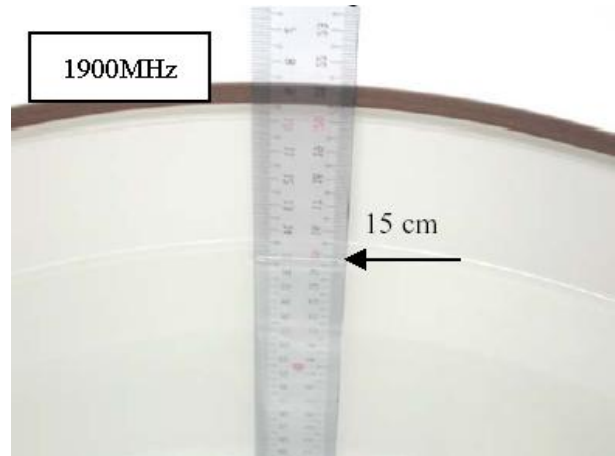

Fig.5 Photograph of the Tissue Simulant Liquid depth 15cm for Body-Worn

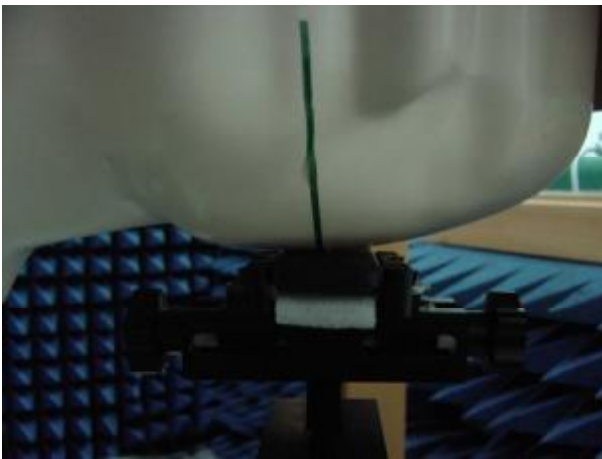

Fig.6 Photograph of the Left Hand Side Cheek status

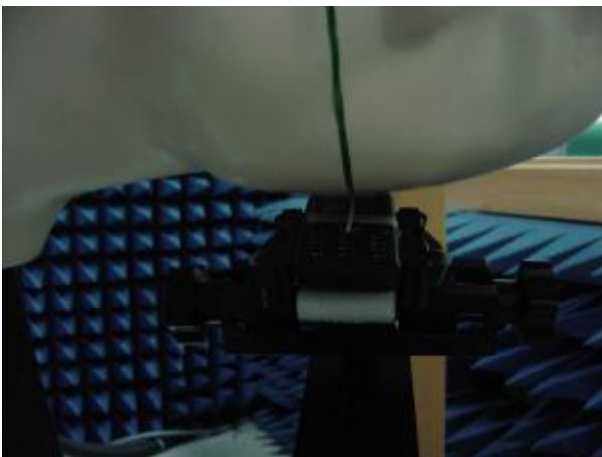
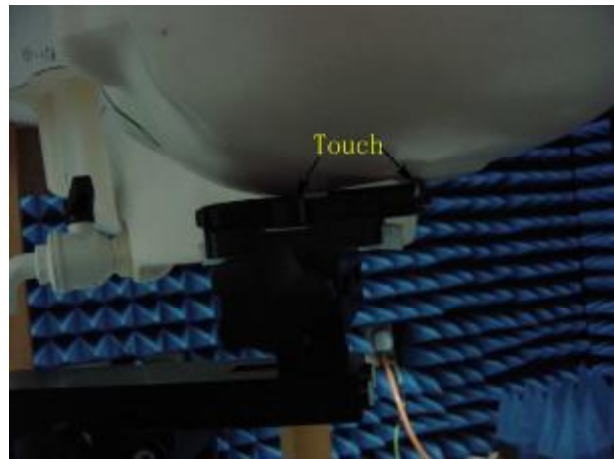
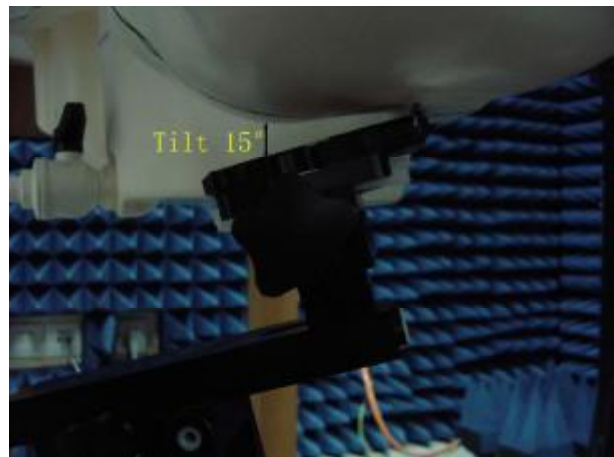

Fig.7 Photograph of the Left Hand Side Tilt status



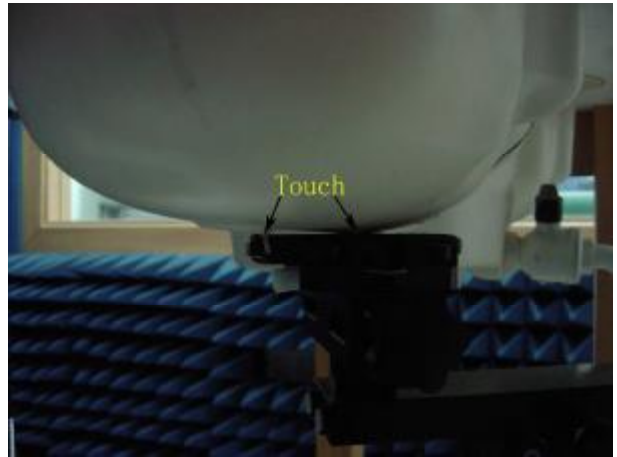
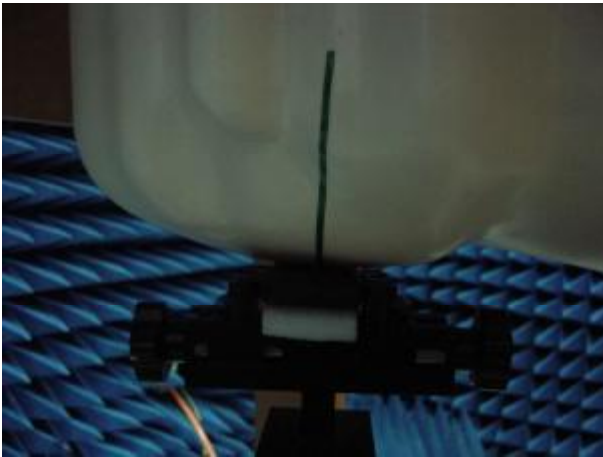

Fig.8 Photograph of the Right Hand Side Cheek status

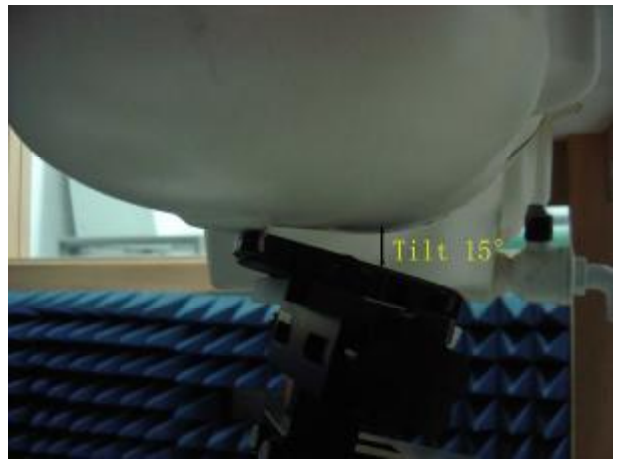
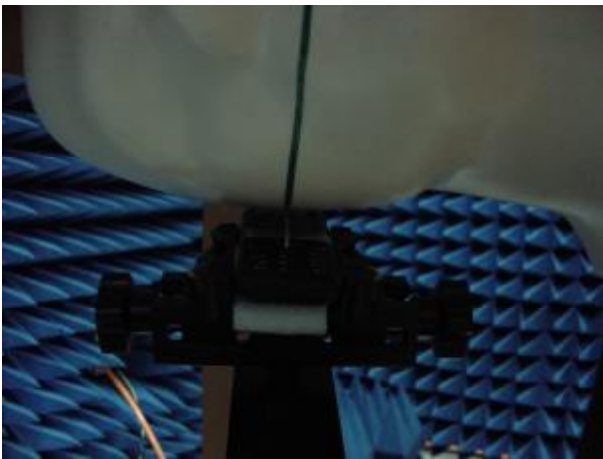

Fig.9 Photograph of the Right Hand Side Tilt status



Fig.10 Photograph of the BodyWorn status

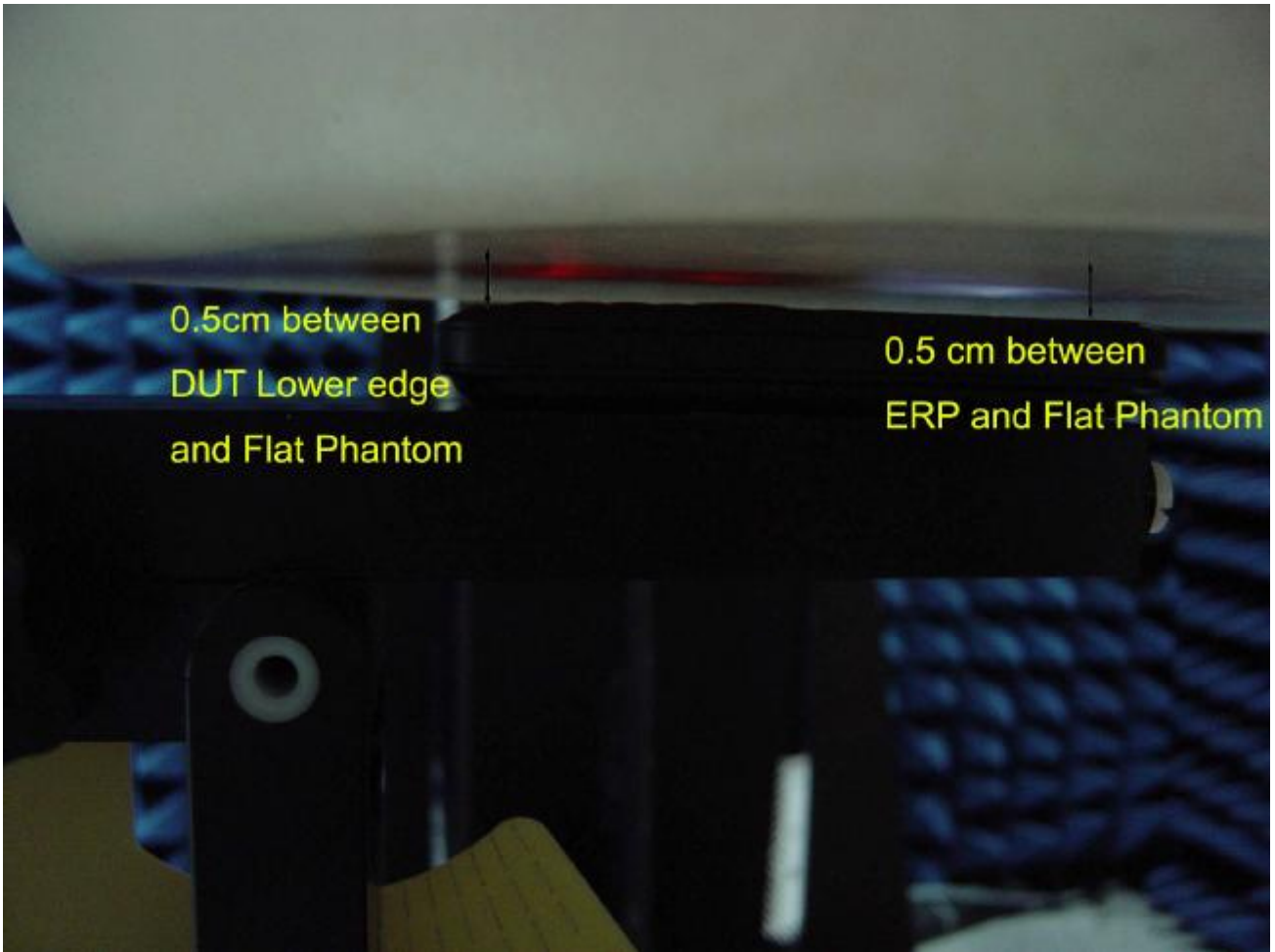

Fig.11 Photograph of the Flat Phantom status

2. Photographs of the EUT



Fig.12 Front View



Fig.13 Back View

3. Photographs of the battery



Fig. 14 Battery For CAB2001010C1



Fig. 15 Battery For CAB2001010C2

4. Photograph of the charger and Headset



Fig.16 Charger



CCA3010000E0

Fig17 Headset

5. Probe Calibration certificate

**Calibration Laboratory of
 Schmid & Partner
 Engineering AG**
 Zaughausstrasse 43, 8004 Zurich, Switzerland



S Schweizerischer Kalibrierdienst
S Service suisse d'étalonnage
C Servizio svizzero di taratura
S Swiss Calibration Service

Accredited by the Swiss Accreditation Service (SAS)
 The Swiss Accreditation Service is one of the signatories to the EA
 Multilateral Agreement for the recognition of calibration certificates

Accreditation No.: **SCS 108**

Client: **SGS China (Auden)**

Certificate No: **ES3-3088_Jan08**

CALIBRATION CERTIFICATE

Object: **ES3DV3 - SN:3088**

Calibration procedure(s): **QA CAL-01.v6
 Calibration procedure for dosimetric E-field probes**

Calibration date: **January 18, 2008**

Condition of the calibrated item: **In Tolerance**

This calibration certificate documents the traceability to national standards, which realize the physical units of measurements (SI).
 The measurements and the uncertainties with confidence probability are given on the following pages and are part of the certificate.
 All calibrations have been conducted in the closed laboratory facility: environment temperature (22 ± 3°C and humidity < 70%).

Calibration Equipment used (M&TE critical for calibration)

Primary Standards	ID #	Cal Date (Calibrated by, Certificate No.)	Scheduled Calibration
Power meter E4419B	GG41293874	29-Mar-07 (METAS, No. 217-00670)	Mar-08
Power sensor E4412A	MY41496277	29-Mar-07 (METAS, No. 217-00670)	Mar-08
Power sensor E4412A	MY41496067	29-Mar-07 (METAS, No. 217-00670)	Mar-08
Reference 3 dB Attenuator	SN: S5054 (3c)	8-Aug-07 (METAS, No. 217-00719)	Aug-08
Reference 20 dB Attenuator	SN: S5086 (20b)	29-Mar-07 (METAS, No. 217-00671)	Mar-08
Reference 30 dB Attenuator	SN: S5125 (30b)	8-Aug-07 (METAS, No. 217-00720)	Aug-08
Reference Probe ES3DV2	SN: 3013	2-Jan-08 (SPEAG, No. ES3-0013_Jan08)	Jan-09
DAE4	SN: 654	20-Apr-07 (SPEAG, No. DAE4-654_Apr07)	Apr-08

Secondary Standards	ID #	Check Date (in house)	Scheduled Check
RF generator HP 8648C	US3F42UD1700	4-Aug-95 (SPEAG, in house check Oct-07)	In house check: Oct-09
Network Analyzer HP 8753E	US37390685	18-Oct-01 (SPEAG, in house check Oct-07)	In house check: Oct-08

	Name	Function	Signature
Calibrated by:	Katja Pokrowic	Technical Manager	
Approved by:	Niels Kuster	Quality Manager	

Issued: January 18, 2008

This calibration certificate shall not be reproduced except in full without written approval of the laboratory.

Calibration Laboratory of
Schmid & Partner
Engineering AG
Zeughausstrasse 43, 8004 Zurich, Switzerland



S Schweizerischer Kalibrierdienst
C Service suisse d'étalonnage
S Servizio svizzero di taratura
S Swiss Calibration Service

Accredited by the Swiss Accreditation Service (SAS)
The Swiss Accreditation Service is one of the signatories to the EA
Multilateral Agreement for the recognition of calibration certificates

Accreditation No.: SCS 108

Glossary:

TSL	tissue simulating liquid
NORM _{x,y,z}	sensitivity in free space
ConF	sensitivity in TSL / NORM _{x,y,z}
DCP	diode compression point
Polarization φ	φ rotation around probe axis
Polarization ϑ	ϑ rotation around an axis that is in the plane normal to probe axis (at measurement center), i.e., $\vartheta = 0$ is normal to probe axis

Calibration is Performed According to the Following Standards:

- IEEE Std 1528-2003, "IEEE Recommended Practice for Determining the Peak Spatial-Averaged Specific Absorption Rate (SAR) in the Human Head from Wireless Communications Devices: Measurement Techniques", December 2003
- IEC 62209-1, "Procedure to measure the Specific Absorption Rate (SAR) for hand-held devices used in close proximity to the ear (frequency range of 300 MHz to 3 GHz)", February 2005

Methods Applied and Interpretation of Parameters:

- NORM_{x,y,z}**: Assessed for E-field polarization $\vartheta = 0$ ($f \leq 900$ MHz in TEM-cell; $f > 1800$ MHz: R22 waveguide). NORM_{x,y,z} are only intermediate values, i.e., the uncertainties of NORM_{x,y,z} does not effect the E²-field uncertainty inside TSL (see below *ConvF*).
- NORM(f)_{x,y,z}** = NORM_{x,y,z} * *frequency_response* (see Frequency Response Chart). This linearization is implemented in DASY4 software versions later than 4.2. The uncertainty of the frequency response is included in the stated uncertainty of *ConvF*.
- DCP_{x,y,z}**: DCP are numerical linearization parameters assessed based on the data of power sweep (no uncertainty required). DCP does not depend on frequency nor media.
- ConvF and Boundary Effect Parameters**: Assessed in flat phantom using E-field (or Temperature Transfer Standard for $f \leq 800$ MHz) and inside waveguide using analytical field distributions based on power measurements for $f > 800$ MHz. The same setups are used for assessment of the parameters applied for boundary compensation (alpha, depth) of which typical uncertainty values are given. These parameters are used in DASY4 software to improve probe accuracy close to the boundary. The sensitivity in TSL corresponds to NORM_{x,y,z} * *ConvF* whereby the uncertainty corresponds to that given for *ConvF*. A frequency dependent *ConvF* is used in DASY version 4.4 and higher which allows extending the validity from ± 50 MHz to ± 100 MHz.
- Spherical isotropy (3D deviation from isotropy)**: in a field of low gradients realized using a flat phantom exposed by a patch antenna.
- Sensor Offset**: The sensor offset corresponds to the offset of virtual measurement center from the probe tip (on probe axis). No tolerance required.

ES3DV3 SN:3088

January 18, 2008

Probe ES3DV3

SN:3088

Manufactured:	July 20, 2005
Last calibrated:	December 12, 2006
Recalibrated:	January 18, 2008

Calibrated for DASY Systems

(Note: non-compatible with DASY2 system!)

ES3DV3 SN:3088

January 18, 2008

DASY - Parameters of Probe: ES3DV3 SN:3088

Sensitivity in Free Space^A

NormX	1.31 ± 10.1%	$\mu\text{V}/(\text{V}/\text{m})^2$
NormY	1.26 ± 10.1%	$\mu\text{V}/(\text{V}/\text{m})^2$
NormZ	1.24 ± 10.1%	$\mu\text{V}/(\text{V}/\text{m})^2$

Diode Compression^B

DCP X	92 mV
DCP Y	93 mV
DCP Z	93 mV

Sensitivity in Tissue Simulating Liquid (Conversion Factors)

Please see Page 8.

Boundary Effect

TSL 900 MHz Typical SAR gradient: 5 % per mm

Sensor Center to Phantom Surface Distance		3.0 mm	4.0 mm
SAR _{be} [%]	Without Correction Algorithm	11.0	6.8
SAR _{be} [%]	With Correction Algorithm	0.9	0.4

TSL 1750 MHz Typical SAR gradient: 10 % per mm

Sensor Center to Phantom Surface Distance		3.0 mm	4.0 mm
SAR _{be} [%]	Without Correction Algorithm	9.6	5.1
SAR _{be} [%]	With Correction Algorithm	0.7	0.9

Sensor Offset

Probe Tip to Sensor Center **2.0 mm**

The reported uncertainty of measurement is stated as the standard uncertainty of measurement multiplied by the coverage factor k=2, which for a normal distribution corresponds to a coverage probability of approximately 95%.

^A The uncertainties of NormX,Y,Z do not affect the E²-field uncertainty inside TSL (see Page 8).

^B Numerical linearization parameter: uncertainty not required.

ES3DV3 SN:3088

January 18, 2008

Frequency Response of E-Field

(TEM-Cell:ifi110 EXX, Waveguide: R22)

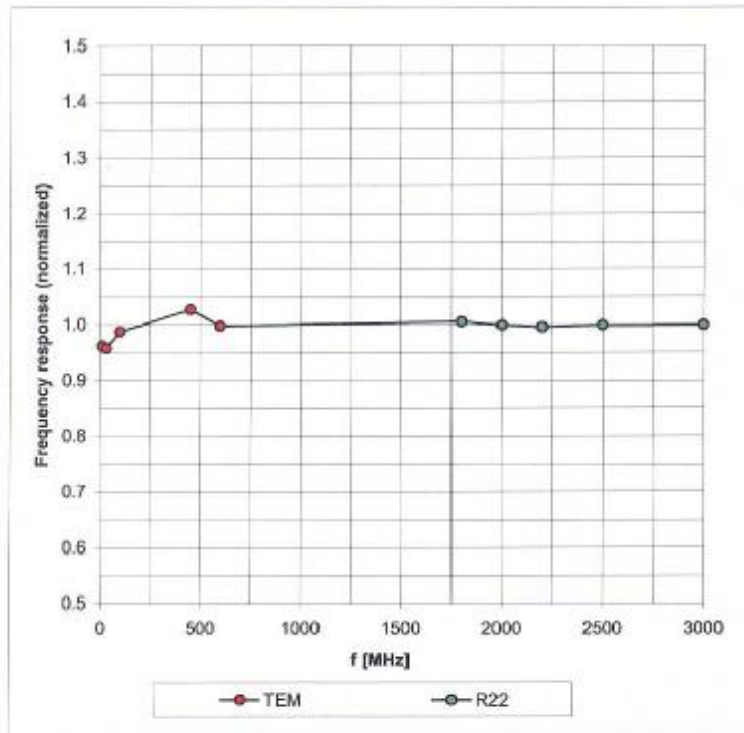

Uncertainty of Frequency Response of E-field: $\pm 6.3\%$ ($k=2$)

ES3DV3 SN:3088

January 18, 2008

Receiving Pattern (ϕ), $\vartheta = 0^\circ$

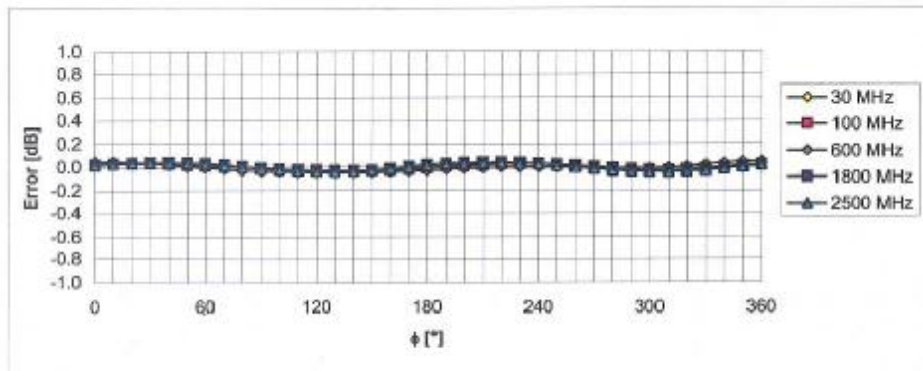
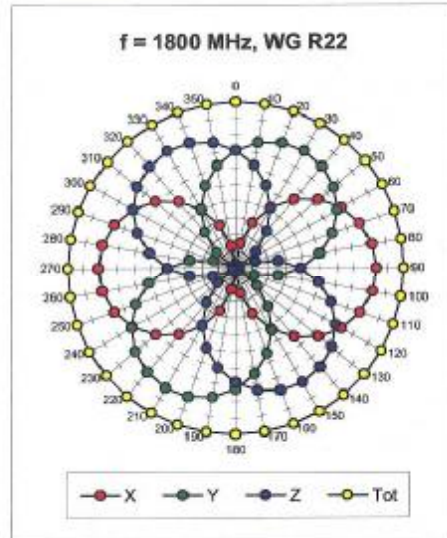
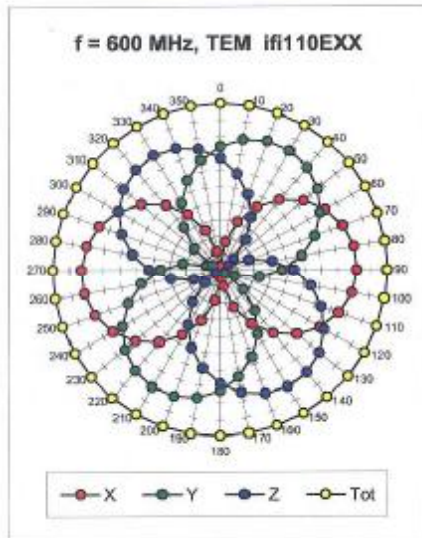

Uncertainty of Axial Isotropy Assessment: $\pm 0.5\%$ ($k=2$)

ES3DV3 SN:3088

January 18, 2008

Dynamic Range $f(SAR_{head})$ (Waveguide R22, $f = 1800$ MHz)

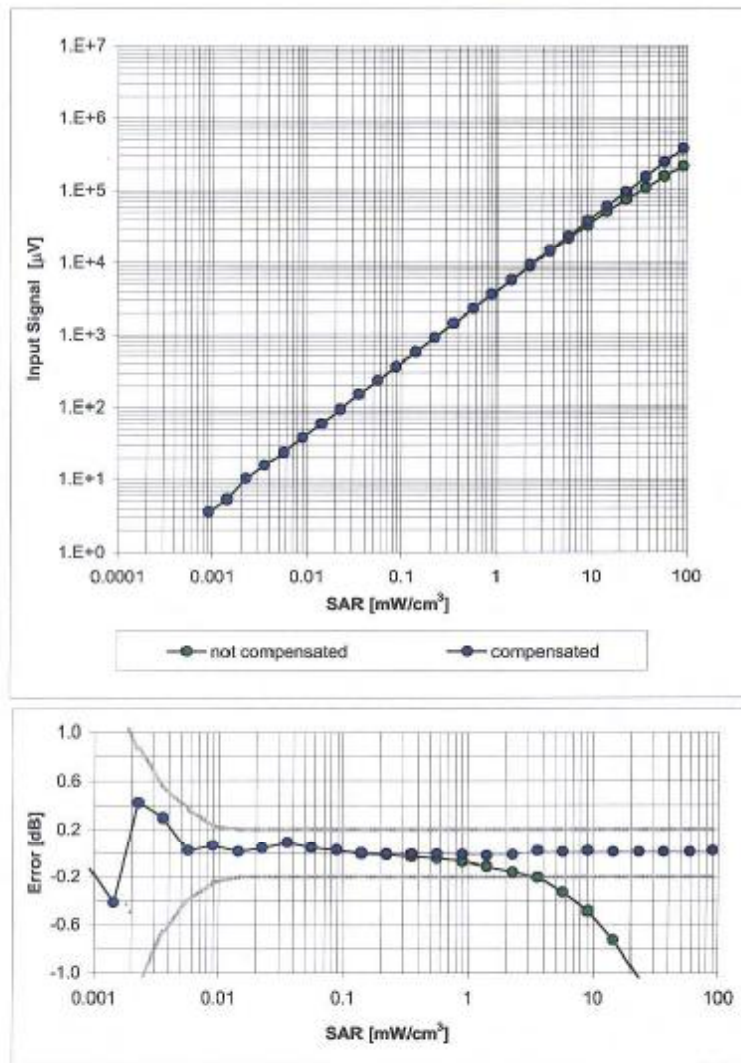

Uncertainty of Linearity Assessment: $\pm 0.6\%$ ($k=2$)

ES3DV3 SN:3088

January 18, 2008

Conversion Factor Assessment

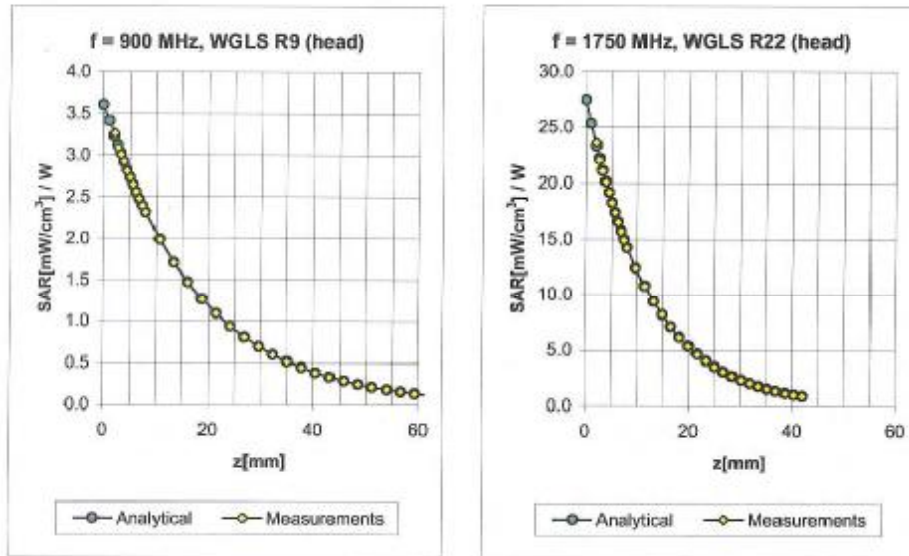

f [MHz]	Validity [MHz] ^c	TSL	Permittivity	Conductivity	Alpha	Depth	ConvF Uncertainty
900	± 50 / ± 100	Head	41.5 ± 5%	0.97 ± 5%	0.90	1.23	6.15 ± 11.0% (k=2)
1750	± 50 / ± 100	Head	40.1 ± 5%	1.37 ± 5%	0.93	1.18	5.04 ± 11.0% (k=2)
1950	± 50 / ± 100	Head	40.0 ± 5%	1.40 ± 5%	0.73	1.35	4.84 ± 11.0% (k=2)
2450	± 50 / ± 100	Head	39.2 ± 5%	1.80 ± 5%	0.70	1.39	4.53 ± 11.8% (k=2)
900	± 50 / ± 100	Body	55.0 ± 5%	1.05 ± 5%	0.95	1.14	5.81 ± 11.0% (k=2)
1750	± 50 / ± 100	Body	53.4 ± 5%	1.49 ± 5%	0.90	1.17	4.92 ± 11.0% (k=2)
1950	± 50 / ± 100	Body	53.3 ± 5%	1.52 ± 5%	0.84	1.23	4.60 ± 11.0% (k=2)
2450	± 50 / ± 100	Body	52.7 ± 5%	1.95 ± 5%	0.84	1.17	4.13 ± 11.8% (k=2)

^c The validity of ± 100 MHz only applies for DASY v4.4 and higher (see Page 2). The uncertainty is the RSS of the ConvF uncertainty at calibration frequency and the uncertainty for the indicated frequency band.

ES3DV3 SN:3088

January 18, 2008

Deviation from Isotropy in HSL** Error (ϕ , θ), $f = 900$ MHz

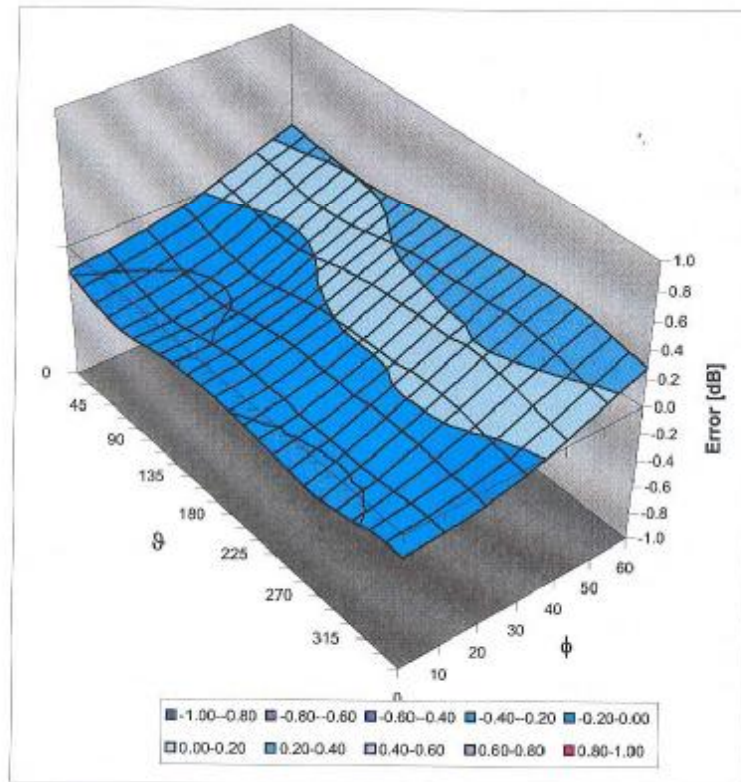

Uncertainty of Spherical Isotropy Assessment: $\pm 2.6\%$ ($k=2$)

6. DAE Calibration certification

Schmid & Partner Engineering AG

s p e a g

Zughausstrasse 43, 8004 Zurich, Switzerland
Phone +41 44 245 9700, Fax +41 44 245 9779
info@speag.com, <http://www.speag.com>

IMPORTANT NOTICE

USAGE OF THE DAE 3

The DAE unit is a delicate, high precision instrument and requires careful treatment by the user. There are no serviceable parts inside the DAE. Special attention shall be given to the following points:

Battery Exchange: The battery cover of the DAE3 unit is connected to a fragile 3-pin battery connector. Customer is responsible to apply utmost caution not to bend or damage the connector when changing batteries.

Shipping of the DAE: Before shipping the DAE to SPEAG for calibration Customer shall remove the batteries and pack the DAE in an antistatic bag. The packaging shall protect the DAE from impacts during transportation. The package shall be marked to indicate that a fragile instrument is inside.

E-Stop Failures: Touch detection may be malfunctioning due to broken magnets in the E-stop. Rough handling of the E-stop may lead to damage of these magnets. Touch and collision errors are often caused by dust and dirt accumulated in the E-stop. To prevent E-stop failure, Customer shall always mount the probe to the DAE carefully and keep the DAE unit in a non-dusty environment if not used for measurements.

Repair: Minor repairs are performed at no extra cost during the annual calibration. However, SPEAG reserves the right to charge for any repair especially if rough unprofessional handling caused the defect.

Important Note:

Warranty and calibration is void if the DAE unit is disassembled partly or fully by the Customer.

Important Note:

Never attempt to grease or oil the E-stop assembly. Cleaning and readjusting of the E-stop assembly is allowed by certified SPEAG personnel only and is part of the annual calibration procedure.

Schmid & Partner Engineering

**Calibration Laboratory of
 Schmid & Partner
 Engineering AG**
 Zeughausstrasse 43, 8004 Zurich, Switzerland



S Schweizerischer Kalibrierdienst
C Service suisse d'étalonnage
S Servizio svizzero di taratura
S Swiss Calibration Service

Accredited by the Swiss Accreditation Service (SAS)
 The Swiss Accreditation Service is one of the signatories to the EA
 Multilateral Agreement for the recognition of calibration certificates

Accreditation No.: **SCS 108**

Client **SGS – CSTC (MTT)**

Certificate No: **DAE3-569_Nov07**

CALIBRATION CERTIFICATE

Object **DAE3 - SD 000 D03 AA - SN: 569**

Calibration procedure(s) **QA CAL-06.v12
 Calibration procedure for the data acquisition electronics (DAE)**

Calibration date: **November 19, 2007**

Condition of the calibrated item **In Tolerance**

This calibration certificate documents the traceability to national standards, which realize the physical units of measurements (SI).
 The measurements and the uncertainties with confidence probability are given on the following pages and are part of the certificate.

All calibrations have been conducted in the closed laboratory facility: environment temperature (22 ± 3)°C and humidity < 70%.

Calibration Equipment used (M&TE critical for calibration)

Primary Standards	ID #	Cal Date (Calibrated by, Certificate No.)	Scheduled Calibration
Fluke Process Calibrator Type 702	SN: 6295803	04-Oct-07 (Elcal AG, No: 6467)	Oct-08
Keithley Multimeter Type 2001	SN: 0810278	03-Oct-07 (Elcal AG, No: 6465)	Oct-08
Secondary Standards	ID #	Check Date (in house)	Scheduled Check
Calibrator Box V1.1	SE UMS 006 AB 1004	25-Jun-07 (SPEAG, in house check)	In house check Jun-08

	Name	Function	Signature
Calibrated by:	Dominique Steffen	Technician	<i>[Signature]</i>
Approved by:	Fin Bornholt	R&D Director	<i>[Signature]</i>

Issued: November 19, 2007

This calibration certificate shall not be reproduced except in full without written approval of the laboratory.

**Calibration Laboratory of
Schmid & Partner
Engineering AG**
Zeughausstrasse 43, 8004 Zurich, Switzerland



S Schweizerischer Kalibrierdienst
C Service suisse d'étalonnage
S Servizio svizzero di taratura
S Swiss Calibration Service

Accredited by the Swiss Federal Office of Metrology and Accreditation
The Swiss Accreditation Service is one of the signatories to the EA
Multilateral Agreement for the recognition of calibration certificates

Accreditation No.: **SCS 108**

Glossary

DAE data acquisition electronics
Connector angle information used in DASY system to align probe sensor X to the robot coordinate system.

Methods Applied and Interpretation of Parameters

- *DC Voltage Measurement*: Calibration Factor assessed for use in DASY system by comparison with a calibrated instrument traceable to national standards. The figure given corresponds to the full scale range of the voltmeter in the respective range.
- *Connector angle*: The angle of the connector is assessed measuring the angle mechanically by a tool inserted. Uncertainty is not required.
- The following parameters as documented in the Appendix contain technical information as a result from the performance test and require no uncertainty.
 - *DC Voltage Measurement Linearity*: Verification of the Linearity at +10% and -10% of the nominal calibration voltage. Influence of offset voltage is included in this measurement.
 - *Common mode sensitivity*: Influence of a positive or negative common mode voltage on the differential measurement.
 - *Channel separation*: Influence of a voltage on the neighbor channels not subject to an input voltage.
 - *AD Converter Values with inputs shorted*: Values on the internal AD converter corresponding to zero input voltage
 - *Input Offset Measurement*: Output voltage and statistical results over a large number of zero voltage measurements.
 - *Input Offset Current*: Typical value for information; Maximum channel input offset current, not considering the input resistance.
 - *Input resistance*: DAE input resistance at the connector, during internal auto-zeroing and during measurement.
 - *Low Battery Alarm Voltage*: Typical value for information. Below this voltage, a battery alarm signal is generated.
 - *Power consumption*: Typical value for information. Supply currents in various operating modes.

DC Voltage Measurement

A/D - Converter Resolution nominal

High Range: 1LSB = 6.1 μ V , full range = -100...+300 mV
Low Range: 1LSB = 61nV , full range = -1.....+3mV

DASY measurement parameters: Auto Zero Time: 3 sec; Measuring time: 3 sec

Calibration Factors	X	Y	Z
High Range	404.776 \pm 0.1% (k=2)	404.362 \pm 0.1% (k=2)	404.137 \pm 0.1% (k=2)
Low Range	3.94862 \pm 0.7% (k=2)	3.94274 \pm 0.7% (k=2)	3.94290 \pm 0.7% (k=2)

Connector Angle

Connector Angle to be used in DASY system	265 $^{\circ}$ \pm 1 $^{\circ}$
---	-----------------------------------

Appendix

1. DC Voltage Linearity

High Range	Input (μV)	Reading (μV)	Error (%)
Channel X + Input	200000	199999.4	0.00
Channel X + Input	20000	20003.10	0.02
Channel X - Input	20000	-19998.40	-0.01
Channel Y + Input	200000	199999.8	0.00
Channel Y + Input	20000	20000.56	0.00
Channel Y - Input	20000	-20003.76	0.02
Channel Z + Input	200000	199999.7	0.00
Channel Z + Input	20000	19999.91	0.00
Channel Z - Input	20000	-20001.93	0.01

Low Range	Input (μV)	Reading (μV)	Error (%)
Channel X + Input	2000	2000	0.00
Channel X + Input	200	199.91	-0.05
Channel X - Input	200	-200.13	0.06
Channel Y + Input	2000	2000	0.00
Channel Y + Input	200	198.90	-0.55
Channel Y - Input	200	-200.33	0.17
Channel Z + Input	2000	2000	0.00
Channel Z + Input	200	198.87	-0.56
Channel Z - Input	200	-200.97	0.48

2. Common mode sensitivity

DASY measurement parameters: Auto Zero Time: 3 sec; Measuring time: 3 sec

	Common mode Input Voltage (mV)	High Range Average Reading (μV)	Low Range Average Reading (μV)
Channel X	200	-5.51	-5.11
	- 200	9.14	5.16
Channel Y	200	7.38	7.24
	- 200	-8.13	-8.74
Channel Z	200	-5.41	-5.65
	- 200	4.60	4.15

3. Channel separation

DASY measurement parameters: Auto Zero Time: 3 sec; Measuring time: 3 sec

	Input Voltage (mV)	Channel X (μV)	Channel Y (μV)	Channel Z (μV)
Channel X	200	-	1.82	0.97
Channel Y	200	0.44	-	3.38
Channel Z	200	-0.57	-0.43	-

4. AD-Converter Values with inputs shorted

DASY measurement parameters: Auto Zero Time: 3 sec; Measuring time: 3 sec

	High Range (LSB)	Low Range (LSB)
Channel X	16395	15475
Channel Y	15747	16647
Channel Z	16314	16212

5. Input Offset Measurement

DASY measurement parameters: Auto Zero Time: 3 sec; Measuring time: 3 sec

Input 10M Ω

	Average (μ V)	min. Offset (μ V)	max. Offset (μ V)	Std. Deviation (μ V)
Channel X	-0.02	-0.85	1.22	0.32
Channel Y	-0.62	-1.53	0.45	0.30
Channel Z	-0.95	-2.89	-0.14	0.35

6. Input Offset Current

Nominal Input circuitry offset current on all channels: <25fA

7. Input Resistance

	Zeroing (MOhm)	Measuring (MOhm)
Channel X	0.2000	199.3
Channel Y	0.2000	203.2
Channel Z	0.2001	204.8

8. Low Battery Alarm Voltage (verified during pre test)

Typical values	Alarm Level (VDC)
Supply (+ Vcc)	+7.9
Supply (- Vcc)	-7.6

9. Power Consumption (verified during pre test)

Typical values	Switched off (mA)	Stand by (mA)	Transmitting (mA)
Supply (+ Vcc)	+0.0	+6	+14
Supply (- Vcc)	-0.01	-8	-9

7. Dipole Calibration certification

**Calibration Laboratory of
Schmid & Partner
Engineering AG**
Zeughausstrasse 43, 8004 Zurich, Switzerland



S Schweizerischer Kalibrierdienst
C Service suisse d'étalonnage
S Servizio svizzero di taratura
S Swiss Calibration Service

Accredited by the Swiss Accreditation Service (SAS)
The Swiss Accreditation Service is one of the signatories to the EA
Multilateral Agreement for the recognition of calibration certificates

Accreditation No.: **SCS 108**Client: **SGS China (Auden)**Certificate No.: **D900V2-184_Dec07****CALIBRATION CERTIFICATE**

Object: **D900V2 - SN: 184**

Calibration procedure(s): **QA CAL-05.v7
Calibration procedure for dipole validation kits**

Calibration date: **December 21, 2007**

Condition of the calibrated item: **In Tolerance**

This calibration certificate documents the traceability to national standards, which realize the physical units of measurements (SI).
The measurements and the uncertainties with confidence probability are given on the following pages and are part of the certificate.

All calibrations have been conducted in the closed laboratory facility: environment temperature (22 ± 3)°C and humidity < 70%.

Calibration Equipment used (V&E critical for calibration)

Primary Standards	ID #	Cal Date (Calibrated by, Certificate No.)	Scheduled Calibration
Power meter EPM-442A	GB37480704	04-Oct-07 (METAS, No. 217-00736)	Oct-08
Power sensor HP 8481A	LS37292783	04-Oct-07 (METAS, No. 217-00736)	Oct-08
Reference 20 dB Attenuator	SN: 5036 (20g)	07-Aug-07 (METAS, No 217-00718)	Aug-08
Reference 10 dB Attenuator	SN: 5047.2 (10g)	07-Aug-07 (METAS, No 217-00718)	Aug-08
Reference Probe ET3DV5 (HF)	SN 1507	26-Oct-07 (SPEAG, No. ET3-1507_Oct07)	Oct-08
DAE4	SN 601	30-Jan-07 (SPEAG, No. DAE4-601_Jan07)	Jan-08
Secondary Standards	ID #	Check Date (in house)	Scheduled Check
Power sensor HP 8481A	MY41092317	16-Oct-02 (SPEAG, in house check Oct-07)	In house check: Oct-08
RF generator R&S SMT-06	130005	4-Aug-99 (SPEAG, in house check Oct-07)	In house check: Oct-08
Network Analyzer HP 8753F	LIS37390585 S4236	18-Oct-01 (SPEAG, in house check Oct-07)	In house check: Oct-08

Calibrated by:	Name	Function	Signature
	Mike Meib	Laboratory Technician	
Approved by:	Name	Technical Manager	Signature
	Katja Pokovic	Technical Manager	

Issued: December 21, 2007

This calibration certificate shall not be reproduced except in full without written approval of the laboratory.

**Calibration Laboratory of
Schmid & Partner
Engineering AG**
Zeughausstrasse 43, 8004 Zurich, Switzerland



S Schweizerischer Kalibrierdienst
C Service suisse d'étalonnage
S Servizio svizzero di taratura
S Swiss Calibration Service

Accredited by the Swiss Accreditation Service (SAS)
The Swiss Accreditation Service is one of the signatories to the EA
Multilateral Agreement for the recognition of calibration certificates

Accreditation No.: **SCS 108**

Glossary:

TSL	tissue simulating liquid
ConvF	sensitivity in TSL / NORM x,y,z
N/A	not applicable or not measured

Calibration is Performed According to the Following Standards:

- a) IEEE Std 1528-2003, "IEEE Recommended Practice for Determining the Peak Spatial-Averaged Specific Absorption Rate (SAR) in the Human Head from Wireless Communications Devices: Measurement Techniques", December 2003
- b) IEC 62209-1, "Procedure to measure the Specific Absorption Rate (SAR) for hand-held devices used in close proximity to the ear (frequency range of 300 MHz to 3 GHz)", February 2005
- c) Federal Communications Commission Office of Engineering & Technology (FCC OET), "Evaluating Compliance with FCC Guidelines for Human Exposure to Radiofrequency Electromagnetic Fields; Additional Information for Evaluating Compliance of Mobile and Portable Devices with FCC Limits for Human Exposure to Radiofrequency Emissions", Supplement C (Edition 01-01) to Bulletin 65

Additional Documentation:

- d) DASY4 System Handbook

Methods Applied and Interpretation of Parameters:

- *Measurement Conditions:* Further details are available from the Validation Report at the end of the certificate. All figures stated in the certificate are valid at the frequency indicated.
- *Antenna Parameters with TSL:* The dipole is mounted with the spacer to position its feed point exactly below the center marking of the flat phantom section, with the arms oriented parallel to the body axis.
- *Feed Point Impedance and Return Loss:* These parameters are measured with the dipole positioned under the liquid filled phantom. The impedance stated is transformed from the measurement at the SMA connector to the feed point. The Return Loss ensures low reflected power. No uncertainty required.
- *Electrical Delay:* One-way delay between the SMA connector and the antenna feed point. No uncertainty required.
- *SAR measured:* SAR measured at the stated antenna input power.
- *SAR normalized:* SAR as measured, normalized to an input power of 1 W at the antenna connector.
- *SAR for nominal TSL parameters:* The measured TSL parameters are used to calculate the nominal SAR result.

Measurement Conditions

DASY system configuration, as far as not given on page 1.

DASY Version	DASY4	V4.7
Extrapolation	Advanced Extrapolation	
Phantom	Modular Flat Phantom V4.9	
Distance Dipole Center - TSL	15 mm	with Spacer
Zoom Scan Resolution	dx, dy, dz = 5 mm	
Frequency	900 MHz \pm 1 MHz	

Head TSL parameters

The following parameters and calculations were applied.

	Temperature	Permittivity	Conductivity
Nominal Head TSL parameters	22.0 °C	41.5	0.97 mho/m
Measured Head TSL parameters	(22.0 \pm 0.2) °C	42.5 \pm 6 %	0.98 mho/m \pm 6 %
Head TSL temperature during test	(22.1 \pm 0.2) °C	---	----

SAR result with Head TSL

SAR averaged over 1 cm ³ (1 g) of Head TSL	Condition	
SAR measured	250 mW input power	2.73 mW / g
SAR normalized	normalized to 1W	10.9 mW / g
SAR for nominal Head TSL parameters ¹	normalized to 1W	11.0 mW / g \pm 17.0 % (k=2)

SAR averaged over 10 cm ³ (10 g) of Head TSL	condition	
SAR measured	250 mW input power	1.75 mW / g
SAR normalized	normalized to 1W	7.00 mW / g
SAR for nominal Head TSL parameters ¹	normalized to 1W	7.05 mW / g \pm 16.5 % (k=2)

¹ Correction to nominal TSL parameters according to d), chapter "SAR Sensitivities"

Body TSL parameters

The following parameters and calculations were applied.

	Temperature	Permittivity	Conductivity
Nominal Body TSL parameters	22.0 °C	55.0	1.05 mho/m
Measured Body TSL parameters	(22.0 ± 0.2) °C	54.2 ± 6 %	1.06 mho/m ± 6 %
Body TSL temperature during test	(22.6 ± 0.2) °C	---	---

SAR result with Body TSL

SAR averaged over 1 cm ³ (1 g) of Body TSL	Condition	
SAR measured	250 mW input power	2.90 mW / g
SAR normalized	normalized to 1W	11.6 mW / g
SAR for nominal Body TSL parameters ²	normalized to 1W	11.4 mW / g ± 17.0 % (k=2)

SAR averaged over 10 cm ³ (10 g) of Body TSL	condition	
SAR measured	250 mW input power	1.87 mW / g
SAR normalized	normalized to 1W	7.48 mW / g
SAR for nominal Body TSL parameters ²	normalized to 1W	7.40 mW / g ± 16.5 % (k=2)

² Correction to nominal TSL parameters according to d), chapter "SAR Sensitivities"

Appendix

Antenna Parameters with Head TSL

Impedance, transformed to feed point	48.8 Ω - 7.5 j Ω
Return Loss	- 22.3 dB

Antenna Parameters with Body TSL

Impedance, transformed to feed point	45.3 Ω - 9.4 j Ω
Return Loss	- 19.1 dB

General Antenna Parameters and Design

Electrical Delay (one direction)	1.411 ns
----------------------------------	----------

After long term use with 100W radiated power, only a slight warming of the dipole near the feedpoint can be measured.

The dipole is made of standard semirigid coaxial cable. The center conductor of the feeding line is directly connected to the second arm of the dipole. The antenna is therefore short-circuited for DC-signals.

No excessive force must be applied to the dipole arms, because they might bend or the soldered connections near the feedpoint may be damaged.

Additional EUT Data

Manufactured by	SPEAG
Manufactured on	April 1, 2003

DASY4 Validation Report for Head TSL

Date/Time: 21.12.2007 14:51:24

Test Laboratory: SPEAG, Zurich, Switzerland

DUT: Dipole 900 MHz; Type: D900V2; Serial: D900V2 - SN:184

Communication System: CW; Frequency: 900 MHz; Duty Cycle: 1:1
Medium: HSL 900 MHz;
Medium parameters used: $f = 900$ MHz; $\sigma = 0.98$ mho/m; $\epsilon_r = 42.5$; $\rho = 1000$ kg/m³
Phantom section: Flat Section
Measurement Standard: DASY4 (High Precision Assessment)

DASY4 Configuration:

- Probe: ET3DV6 - SN1507 (HF); ConvF(5.93, 5.93, 5.93); Calibrated: 26.10.2007
- Sensor-Surface: 4mm (Mechanical Surface Detection)
- Electronics: DAE4 Sn601; Calibrated: 30.01.2007
- Phantom: Flat Phantom 4.9L; Type: QD000P49AA
- Measurement SW: DASY4, V4.7 Build 55; Postprocessing SW: SEMCAD, V1.8 Build 172

Pin = 250 mW; d = 15 mm/Zoom Scan (7x7x7)/Cube 0:

Measurement grid: dx=5mm, dy=5mm, dz=5mm
Reference Value = 56.9 V/m; Power Drift = -0.012 dB
Peak SAR (extrapolated) = 4.06 W/kg
SAR(1 g) = 2.73 mW/g; SAR(10 g) = 1.75 mW/g
Maximum value of SAR (measured) = 2.95 mW/g

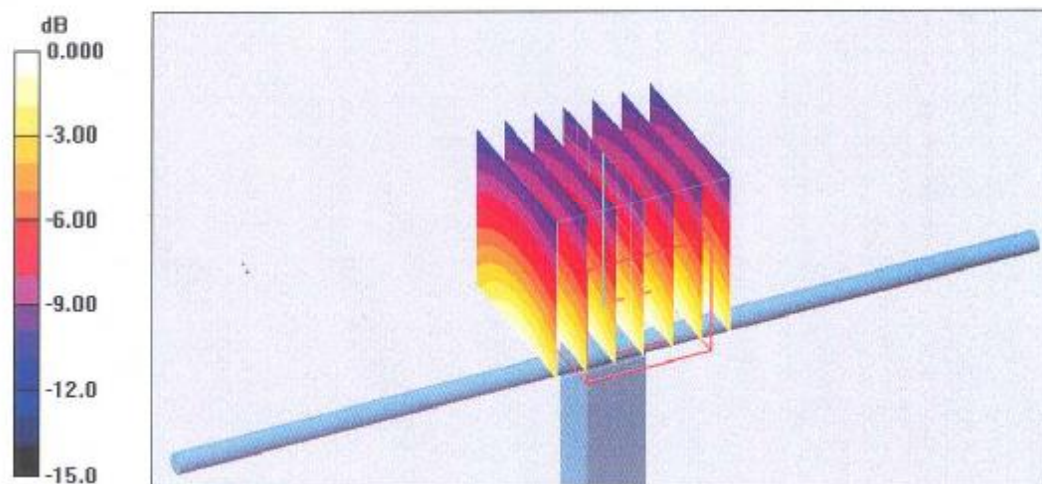

Impedance Measurement Plot for Head TSL

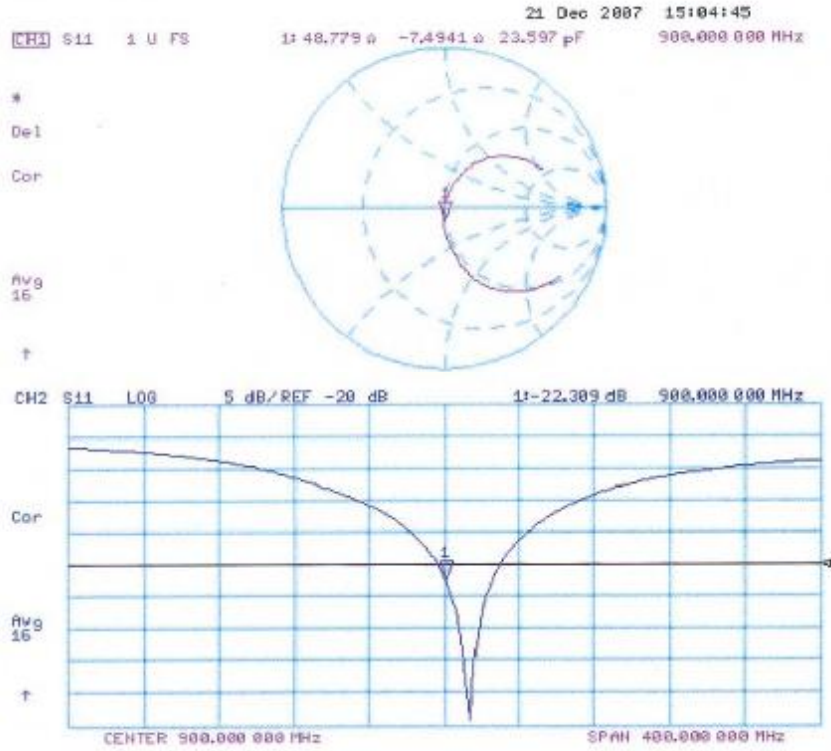

DASY4 Validation Report for Body TSL

Date/Time: 21.12.2007 15:46:31

Test Laboratory: SPEAG, Zurich, Switzerland

DUT: Dipole 900 MHz; Type: D900V2; Serial: D900V2 - SN:184

Communication System: CW; Frequency: 900 MHz; Duty Cycle: 1:1

Medium: MSL900;

Medium parameters used: $f = 900$ MHz; $\sigma = 1.06$ mho/m; $\epsilon_r = 54.2$; $\rho = 1000$ kg/m³

Phantom section: Flat Section

Measurement Standard: DASY4 (High Precision Assessment)

DASY4 Configuration:

- Probe: ET3DV6 - SN1507 (HF); ConvF(5.57, 5.57, 5.57); Calibrated: 26.10.2007
- Sensor-Surface: 4mm (Mechanical Surface Detection)
- Electronics: DAE4 Sn601; Calibrated: 30.01.2007
- Phantom: Flat Phantom 4.9L; Type: QD000P49AA
- Measurement SW: DASY4, V4.7 Build 55; Postprocessing SW: SEMCAD, V1.8 Build 172

Pin=250mW/Zoom Scan (7x7x7)/Cube 0:

Measurement grid: dx=5mm, dy=5mm, dz=5mm

Reference Value = 56.9 V/m; Power Drift = 0.008 dB

Peak SAR (extrapolated) = 4.23 W/kg

SAR(1 g) = 2.9 mW/g; SAR(10 g) = 1.87 mW/g

Maximum value of SAR (measured) = 3.16 mW/g

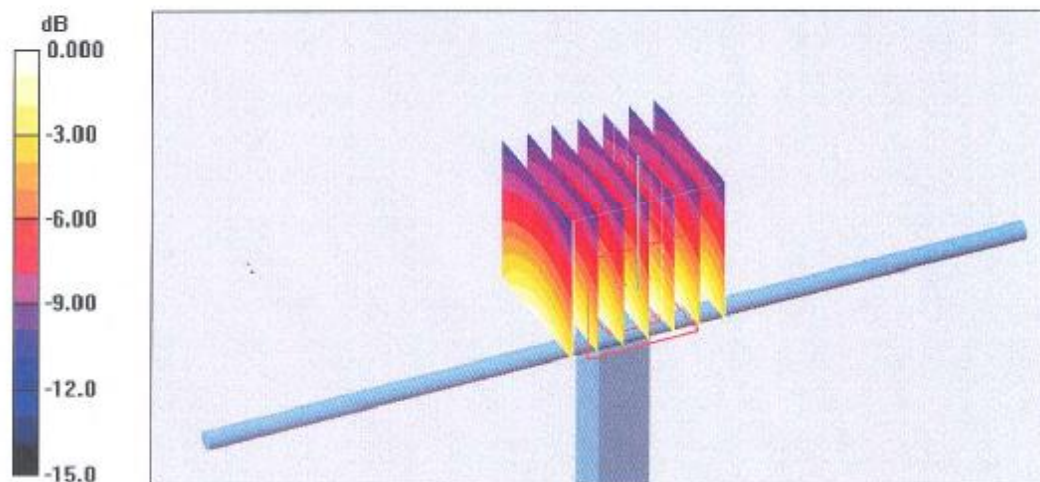

0 dB \approx 3.16mW/g

Impedance Measurement Plot for Body TSL

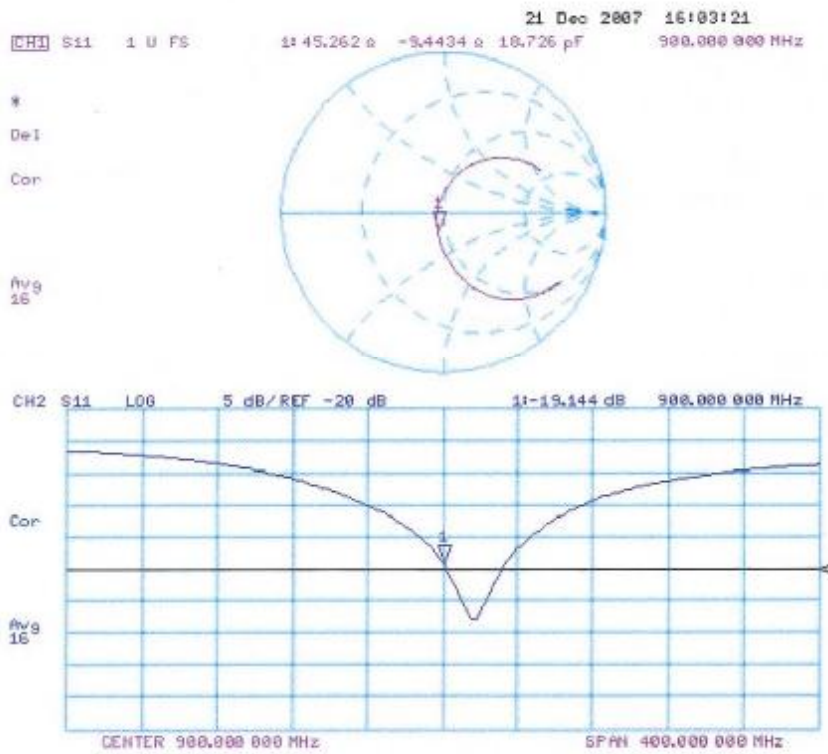

**Calibration Laboratory of
 Schmid & Partner
 Engineering AG**
 Zeughausstrasse 43, 8004 Zurich, Switzerland



S Schweizerischer Kalibrierdienst
S Service suisse d'étalonnage
C Servizio svizzero di taratura
S Swiss Calibration Service

Accredited by the Swiss Accreditation Service (SAS)
 The Swiss Accreditation Service is one of the signatories to the EA
 Multilateral Agreement for the recognition of calibration certificates

Accreditation No.: **SCS 108**

Client **SGS China (Auden)**

Certificate No: **D1900V2-5d028_Dec07**

CALIBRATION CERTIFICATE

Object **D1900V2 - SN: 5d028**

Calibration procedure(s) **QA CAL-05.v7
 Calibration procedure for dipole validation kits**

Calibration date: **December 21, 2007**

Condition of the calibrated item **In Tolerance**

This calibration certificate documents the traceability to national standards, which realize the physical units of measurements (SI).
 The measurements and the uncertainties with confidence probability are given on the following pages and are part of the certificate.

All calibrations have been conducted in the closed laboratory facility: environment temperature (22 ± 3)°C and humidity < 70%.

Calibration Equipment used (M&TE critical for calibration)

Primary Standards	ID #	Cal Date (Calibrated by, Certificate No.)	Scheduled Calibration
Power meter EPM-442A	GB37480704	04-Oct-07 (METAS, No. 217-00736)	Oct-08
Power sensor HP 8481A	US37292783	04-Oct-07 (METAS, No. 217-00736)	Oct-08
Reference 20 dB Attenuator	SN: 5086 (20g)	07-Aug-07 (METAS, No 217-00718)	Aug-08
Reference 10 dB Attenuator	SN: 5047.2 (10r)	07-Aug-07 (METAS, No 217-00718)	Aug-08
Reference Probe ET3DV6 (HF)	SN: 1507	26-Oct-07 (SPEAG, No. ET3-1507_Oct07)	Oct-08
DAE4	SN 601	30-Jan-07 (SPEAG, No. DAE4-601_Jan07)	Jan-08
Secondary Standards	ID #	Check Date (in house)	Scheduled Check
Power sensor HP 8481A	MY41092317	18-Oct-02 (SPEAG, in house check Oct-07)	In house check: Oct-08
RF generator R&S SMT-06	100005	4-Aug-99 (SPEAG, in house check Oct-07)	In house check: Oct-09
Network Analyzer HP 8753E	US37390585 S4206	18-Oct-01 (SPEAG, in house check Oct-07)	In house check: Oct-08

Calibrated by: **Name** Claudio Leubler **Function** Laboratory Technician **Signature** *[Signature]*

Approved by: **Name** Katja Pokovic **Function** Technical Manager **Signature** *[Signature]*

Issued: December 31, 2007

This calibration certificate shall not be reproduced except in full without written approval of the laboratory.

**Calibration Laboratory of
Schmid & Partner
Engineering AG**
Zeughausstrasse 43, 8004 Zurich, Switzerland



S Schweizerischer Kalibrierdienst
C Service suisse d'étalonnage
S Servizio svizzero di taratura
S Swiss Calibration Service

Accredited by the Swiss Accreditation Service (SAS)
The Swiss Accreditation Service is one of the signatories to the EA
Multilateral Agreement for the recognition of calibration certificates

Accreditation No.: **SCS 108**

Glossary:

TSL	tissue simulating liquid
ConvF	sensitivity in TSL / NORM x,y,z
N/A	not applicable or not measured

Calibration is Performed According to the Following Standards:

- IEEE Std 1528-2003, "IEEE Recommended Practice for Determining the Peak Spatial-Averaged Specific Absorption Rate (SAR) in the Human Head from Wireless Communications Devices: Measurement Techniques", December 2003
- IEC 62209-1, "Procedure to measure the Specific Absorption Rate (SAR) for hand-held devices used in close proximity to the ear (frequency range of 300 MHz to 3 GHz)", February 2005
- Federal Communications Commission Office of Engineering & Technology (FCC OET), "Evaluating Compliance with FCC Guidelines for Human Exposure to Radiofrequency Electromagnetic Fields; Additional Information for Evaluating Compliance of Mobile and Portable Devices with FCC Limits for Human Exposure to Radiofrequency Emissions", Supplement C (Edition 01-01) to Bulletin 65

Additional Documentation:

- DASY4 System Handbook

Methods Applied and Interpretation of Parameters:

- Measurement Conditions:* Further details are available from the Validation Report at the end of the certificate. All figures stated in the certificate are valid at the frequency indicated.
- Antenna Parameters with TSL:* The dipole is mounted with the spacer to position its feed point exactly below the center marking of the flat phantom section, with the arms oriented parallel to the body axis.
- Feed Point Impedance and Return Loss:* These parameters are measured with the dipole positioned under the liquid filled phantom. The impedance stated is transformed from the measurement at the SMA connector to the feed point. The Return Loss ensures low reflected power. No uncertainty required.
- Electrical Delay:* One-way delay between the SMA connector and the antenna feed point. No uncertainty required.
- SAR measured:* SAR measured at the stated antenna input power.
- SAR normalized:* SAR as measured, normalized to an input power of 1 W at the antenna connector.
- SAR for nominal TSL parameters:* The measured TSL parameters are used to calculate the nominal SAR result.

Measurement Conditions

DASY system configuration, as far as not given on page 1.

DASY Version	DASY4	V4.7
Extrapolation	Advanced Extrapolation	
Phantom	Modular Flat Phantom V5.0	
Distance Dipole Center - TSL	10 mm	with Spacer
Zoom Scan Resolution	dx, dy, dz = 5 mm	
Frequency	1900 MHz \pm 1 MHz	

Head TSL parameters

The following parameters and calculations were applied.

	Temperature	Permittivity	Conductivity
Nominal Head TSL parameters	22.0 °C	40.0	1.40 mho/m
Measured Head TSL parameters	(22.0 \pm 0.2) °C	39.0 \pm 6 %	1.46 mho/m \pm 6 %
Head TSL temperature during test	(21.5 \pm 0.2) °C	---	---

SAR result with Head TSL

SAR averaged over 1 cm ³ (1 g) of Head TSL	condition	
SAR measured	250 mW input power	9.82 mW / g
SAR normalized	normalized to 1W	39.3 mW / g
SAR for nominal Head TSL parameters ¹	normalized to 1W	37.9 mW / g \pm 17.0 % (k=2)

SAR averaged over 10 cm ³ (10 g) of Head TSL	Condition	
SAR measured	250 mW input power	5.14 mW / g
SAR normalized	normalized to 1W	20.6 mW / g
SAR for nominal Head TSL parameters ¹	normalized to 1W	20.2 mW / g \pm 16.5 % (k=2)

¹ Correction to nominal TSL parameters according to d), chapter "SAR Sensitivities"

Body TSL parameters

The following parameters and calculations were applied.

	Temperature	Permittivity	Conductivity
Nominal Body TSL parameters	22.0 °C	53.3	1.52 mho/m
Measured Body TSL parameters	(22.0 ± 0.2) °C	53.5 ± 6 %	1.54 mho/m ± 6 %
Body TSL temperature during test	(21.5 ± 0.2) °C	---	---

SAR result with Body TSL

SAR averaged over 1 cm ³ (1 g) of Body TSL	Condition	
SAR measured	250 mW input power	9.34 mW / g
SAR normalized	normalized to 1W	37.4 mW / g
SAR for nominal Body TSL parameters ²	normalized to 1W	37.2 mW / g ± 17.0 % (k=2)

SAR averaged over 10 cm ³ (10 g) of Body TSL	condition	
SAR measured	250 mW input power	4.97 mW / g
SAR normalized	normalized to 1W	19.9 mW / g
SAR for nominal Body TSL parameters ²	normalized to 1W	19.8 mW / g ± 16.5 % (k=2)

² Correction to nominal TSL parameters according to d), chapter "SAR Sensitivities"

Appendix**Antenna Parameters with Head TSL**

Impedance, transformed to feed point	$53.7 \Omega + 5.2 j\Omega$
Return Loss	- 24.3 dB

Antenna Parameters with Body TSL

Impedance, transformed to feed point	$49.5 \Omega + 3.4 j\Omega$
Return Loss	- 29.1 dB

General Antenna Parameters and Design

Electrical Delay (one direction)	1.198 ns
----------------------------------	----------

After long term use with 100W radiated power, only a slight warming of the dipole near the feedpoint can be measured.

The dipole is made of standard semirigid coaxial cable. The center conductor of the feeding line is directly connected to the second arm of the dipole. The antenna is therefore short-circuited for DC-signals.

No excessive force must be applied to the dipole arms, because they might bend or the soldered connections near the feedpoint may be damaged.

Additional EUT Data

Manufactured by	SPEAG
Manufactured on	December 17, 2002

DASY4 Validation Report for Head TSL

Date/Time: 21.12.2007 09:54:50

Test Laboratory: SPEAG, Zurich, Switzerland

DUT: Dipole 1900 MHz; Type: D1900V2; Serial: D1900V2 - SN:5d028

Communication System: CW; Frequency: 1900 MHz; Duty Cycle: 1:1
Medium: HSL U10 BB;
Medium parameters used: $f = 1900$ MHz; $\sigma = 1.46$ mho/m; $\epsilon_r = 39$; $\rho = 1000$ kg/m³
Phantom section: Flat Section
Measurement Standard: DASY4 (High Precision Assessment)

DASY4 Configuration:

- Probe: ET3DV6 - SN1507 (HF); ConvF(4.86, 4.86, 4.86); Calibrated: 26.10.2007
- Sensor-Surface: 4mm (Mechanical Surface Detection)
- Electronics: DAE4 Sn601; Calibrated: 30.01.2007
- Phantom: Flat Phantom 5.0 (front); Type: QD000P50AA; ;
- Measurement SW: DASY4, V4.7 Build 55; Postprocessing SW: SEMCAD, V1.8 Build 172

Pin = 250 mW; d = 10 mm/Zoom Scan (7x7x7)/Cube 0:

Measurement grid: $dx=5$ mm, $dy=5$ mm, $dz=5$ mm
Reference Value = 89.9 V/m; Power Drift = 0.010 dB
Peak SAR (extrapolated) = 17.2 W/kg
SAR(1 g) = 9.82 mW/g; SAR(10 g) = 5.14 mW/g
Maximum value of SAR (measured) = 10.9 mW/g

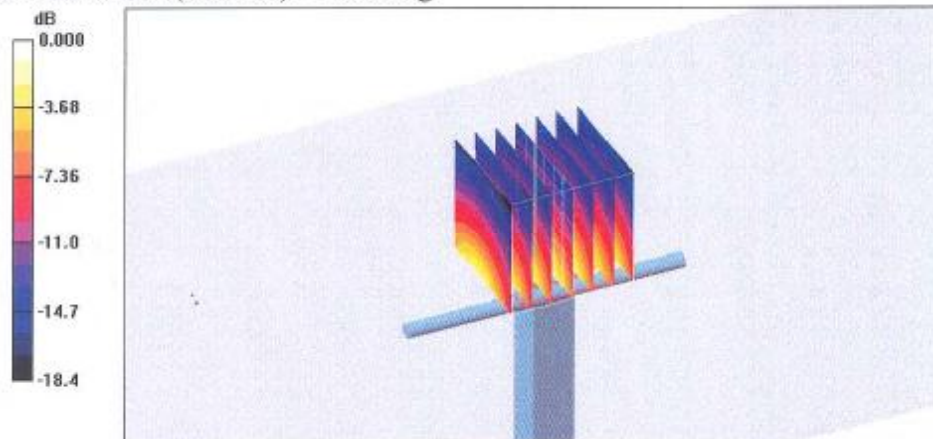

0 dB = 10.9mW/g

Impedance Measurement Plot for Head TSL

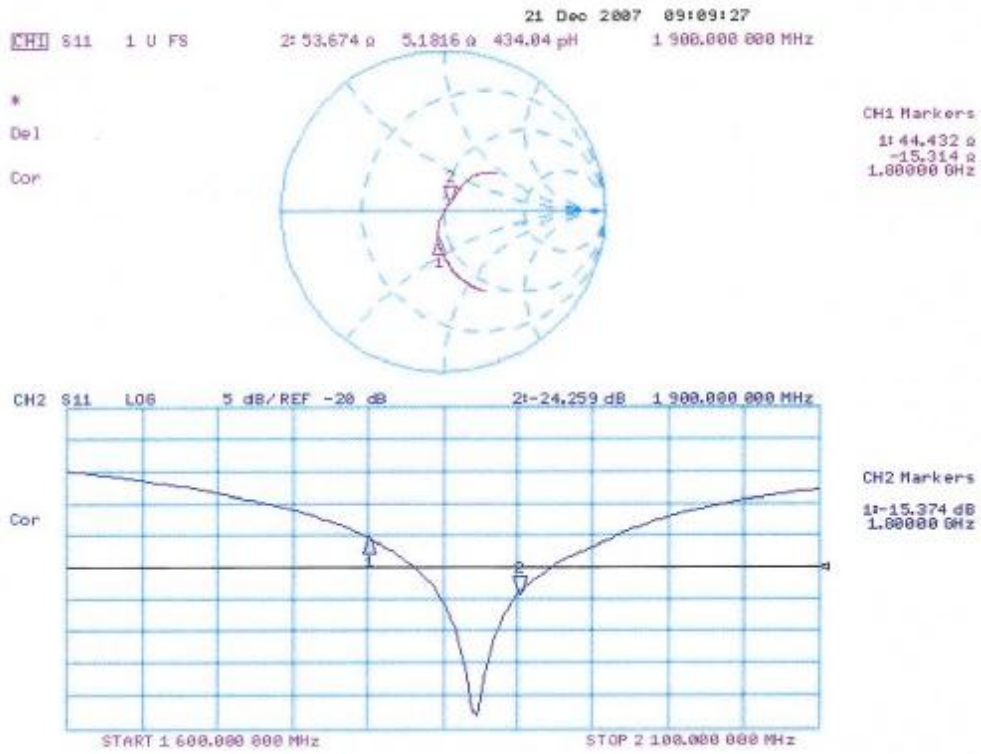

DASY4 Validation Report for Body TSL

Date/Time: 21.12.2007 11:05:06

Test Laboratory: SPEAG, Zurich, Switzerland

DUT: Dipole 1900 MHz; Type: D1900V2; Serial: D1900V2 - SN:5d028

Communication System: CW; Frequency: 1900 MHz; Duty Cycle: 1:1

Medium: MSL U10 BB;

Medium parameters used: $f = 1900$ MHz; $\sigma = 1.54$ mho/m; $\epsilon_r = 53.6$; $\rho = 1000$ kg/m³

Phantom section: Flat Section

Measurement Standard: DASY4 (High Precision Assessment)

DASY4 Configuration:

- Probe: ET3DV6 - SN1507 (HF); ConvF(4.48, 4.48, 4.48); Calibrated: 26.10.2007
- Sensor-Surface: 4mm (Mechanical Surface Detection)
- Electronics: DAE4 Sn601; Calibrated: 30.01.2007
- Phantom: Flat Phantom 5.0 (back); Type: QD000P50AA; ;
- Measurement SW: DASY4, V4.7 Build 55; Postprocessing SW: SEMCAD, V1.8 Build 172

Pin = 250 mW; d = 10 mm/Zoom Scan (7x7x7)/Cube 0:

Measurement grid: dx=5mm, dy=5mm, dz=5mm

Reference Value = 89.3 V/m; Power Drift = -0.044 dB

Peak SAR (extrapolated) = 16.0 W/kg

SAR(1 g) = 9.34 mW/g; SAR(10 g) = 4.97 mW/g

Maximum value of SAR (measured) = 10.5 mW/g

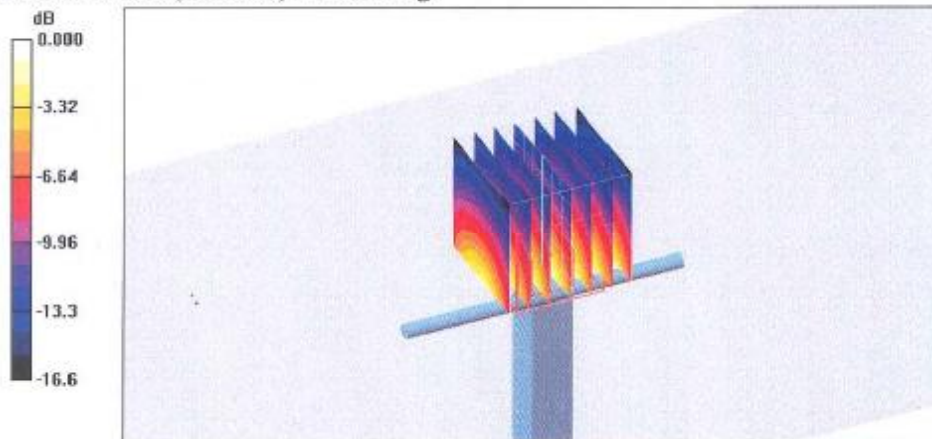

0 dB = 10.5mW/g

Impedance Measurement Plot for Body TSL

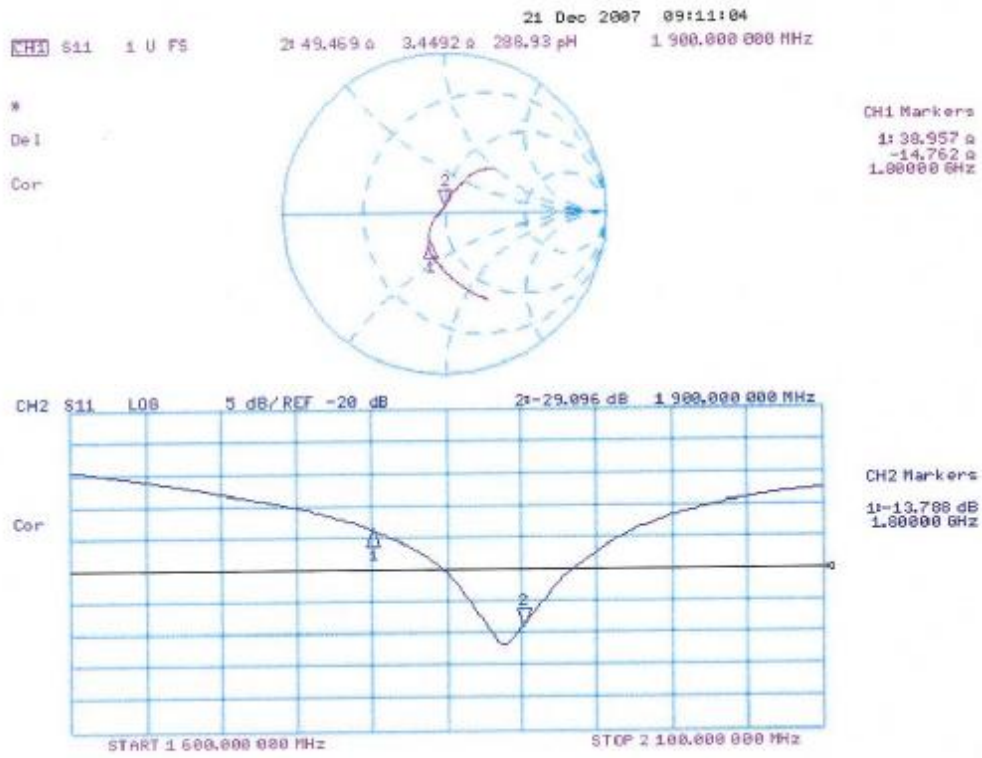

8. Uncertainty analysis

Error Description	Tol. (± %)	Prob. dist.	Div.	(c_1) (1g)	(c_2) (10g)	Std. unc. (± %)		(v_i)
Std. unc. (1g)		Std. unc. (10g)						
Measurement System								
Probe Calibration	4.8	N	1	1	1	4.8	4.8	∞
Axial Isotropy	4.7	R	$\sqrt{3}$	1	1	2.7	2.7	∞
Hemispherical Isotropy	0	R	$\sqrt{3}$	1	1	0	0	∞
Boundary Effects	1.0	R	$\sqrt{3}$	1	1	0.6	0.6	∞
Linearity	4.7	R	$\sqrt{3}$	1	1	2.7	2.7	∞
System Detection Limit	1.0	R	$\sqrt{3}$	1	1	0.6	0.6	∞
Readout Electronics	1.0	N	1	1	1	1.0	1.0	∞
Response Time	0	R	$\sqrt{3}$	1	1	0	0	∞
Integration Time	0	R	$\sqrt{3}$	1	1	0	0	∞
RF Ambient Conditions	3.0	R	$\sqrt{3}$	1	1	1.7	1.7	∞
Probe Positioner	0.4	R	$\sqrt{3}$	1	1	0.2	0.2	∞
Probe Positioning	2.9	R	$\sqrt{3}$	1	1	1.7	1.7	∞
Algorithms for Max. SAR Eval.	1.0	R	$\sqrt{3}$	1	1	0.6	0.6	∞
Dipole								
Dipole Axis to Liquid Distance	2.0	R	$\sqrt{3}$	1	1	1.2	1.2	∞
Input power and SAR drift meas.	4.7	R	$\sqrt{3}$	1	1	2.7	2.7	∞
Phantom and Tissue Param.								
Phantom Uncertainty	4.0	R	$\sqrt{3}$	1	1	2.3	2.3	∞
Liquid Conductivity (target)	5.0	R.	$\sqrt{3}$	0.64	0.43	1.8	1.2	∞
Liquid Conductivity (meas.)	2.5	N	1	0.64	0.43	1.6	1.1	∞
Liquid Permittivity (target)	5.0	R	$\sqrt{3}$	0.6	0.49	1.7	1.4	∞
Liquid Permittivity (meas.)	2.5	N	1	0.6	0.49	1.5	1.2	∞
Combined Standard Uncertainty						8.4	8.1	∞
Coverage Factor for 95%		kp=2						
Expanded Uncertainty						16.8	16.2	

Dasy4 Uncertainty Budget

9. Phantom description

**Schmid & Partner
Engineering AG**

Zeughausstrasse 43, 8004 Zurich, Switzerland, Phone +41 1 245 97 00, Fax +41 1 245 97 79

Certificate of conformity / First Article Inspection

Item	SAM Twin Phantom V4.0
Type No	QD 000 P40 CA
Series No	TP-1150 and higher
Manufacturer / Origin	Unterse Composite Hauptstr. 69 CH-8559 Fruthwilen Switzerland

Tests

The series production process used allows the limitation to test of first articles. Complete tests were made on the pre-series Type No. QD 000 P40 AA, Serial No. TP-1001 and on the series first article Type No. QD 000 P40 BA, Serial No. TP-1006. Certain parameters have been retested using further series units (called samples).

Test	Requirement	Details	Units tested
Shape	Compliance with the geometry according to the CAD model.	ITIS CAD File (*)	First article, Samples
Material thickness	Compliant with the requirements according to the standards	2mm +/- 0.2mm in specific areas	First article, Samples
Material parameters	Dielectric parameters for required frequencies	200 MHz - 3 GHz Relative permittivity < 5 Loss tangent < 0.05.	Material sample TP 104-5
Material resistivity	The material has been tested to be compatible with the liquids defined in the standards	Liquid type HSL 1800 and others according to the standard.	Pre-series, First article

Standards

- [1] CENELEC EN 50361
 [2] IEEE P1528-200x draft 6.5
 [3] IEC PT 62209 draft 0.9
 (*) The ITIS CAD file is derived from [2] and is also within the tolerance requirements of the shapes of [1] and [3].

Conformity

Based on the sample tests above, we certify that this item is in compliance with the uncertainty requirements of SAR measurements specified in standard [1] and draft standards [2] and [3].

Date 28.02.2002

Signature / Stamp

*F. Rombult***Schmid & Partner
Engineering AG**Zeughausstrasse 43, CH-8004 Zurich
Tel. +41 1 245 97 00, Fax +41 1 245 97 79*Volker Kofler***End of Report**