

SAR TEST REPORT

Equipment Under Test :	GSM 850/PCS1900MHz mobile phone
Model No. :	CGL7C
Market name:	OT-E206A
FCC ID :	RAD066
Applicant :	T&A Mobile phones
Address of Applicant :	4/F, No.2966, Jinke Rd, Zhangjiang High-Tech Park, Pudong Shanghai 201203. P. R. China
Date of Receipt :	2007.08.16
Date of Test :	2007.08.20 – 2007.08.27
Date of Issue :	2007.09.04

Standards:

**FCC OET Bulletin 65 supplement C,
ANSI/IEEE C95.1, C95.3, IEEE 1528-2003**

In the configuration tested, the EUT complied with the standards specified above.

Remarks:

This report details the results of the testing carried out on one sample, the results contained in this test report do not relate to other samples of the same product. The manufacturer should ensure that all products in series production are in conformity with the product sample detailed in this report.

This report may only be reproduced and distributed in full. If the product in this report is used in any configuration other than that detailed in the report, the manufacturer must ensure the new system complies with all relevant standards. Any mention of SGS-CSTC Shanghai GSM Lab or testing done by SGS-CSTC Shanghai GSM Lab must approve SGS Shanghai GSM Lab in connection with distribution or use of the product described in this report in writing.

Tested by :

Zeng Zhang

Date :

2007.09.04

Approved by :

Zhiang Yuan

Date :

2007.09.04

Contents

1. General Information	4
1.1 Test Laboratory.....	4
1.2 Details of Applicant	4
1.3 Description of EUT(s).....	4
1.4 Test Environment	5
1.5 Operation Configuration	5
1.6 The SAR Measurement System.....	5
1.7 SAR System Verification.....	6
1.8 Tissue Simulant Fluid for the Frequency Band 850MHz and 1900MHZ	6
1.9 Test Standards and Limits	6
2. Summary of Results	6
3. Instruments List	6
4. Measurements	6
4.1 LeftHandSide-Cheek-GSM850-Middle.....	6
GSM850-LeftHandSide-Cheek-Middle	6
4.2 LeftHandSide-Tilt-GSM850-Middle	6
GSM850-LeftHandSide-Tilt-Middle	6
4.3 LeftHandSide-Cheek-GSM850-Low.....	6
GSM850-LeftHandSide-Cheek-Low	6
4.4 LeftHandSide-Cheek-GSM850-High	6
GSM850-LeftHandSide-Cheek-High	6
4.5 RightHandSide-Cheek-GSM850-Middle	6
GSM850-RightHandSide-Cheek-Middle.....	6
4.6 RightHandSide-Tilt-GSM850-Middle.....	6
GSM850-RightHandSide-Tilt-Middle	6
4.7 RightHandSide-Cheek-GSM850-Low	6
GSM850-RightHandSide-Cheek-Low	6
4.8 RightHandSide-Cheek-GSM850-High	6
GSM850-RightHandSide-Cheek-High	6
4.9 Body-Worn-GSM850-Low.....	6
GSM850-Body-Worn-Low-2.0cm.....	6
4.10 Body-Worn-GSM850-Middle	6
GSM850-Body-Worn-Middle-2.0cm.....	6

4.11 Body-Worn-GSM850-High	6
GSM850-Body-Worn-High-2.0cm	6
4.12 LeftHandSide-Cheek-PCS1900-Middle	6
PCS1900-LeftHandSide-Cheek-Middle	6
4.13 LeftHandSide-Tilt-PCS1900-Middle	6
PCS1900-LeftHandSide-Tilt-Middle	6
4.14 LeftHandSide-Cheek-PCS1900-Low	6
PCS1900-LeftHandSide-Cheek-Low	6
4.15 LeftHandSide-Cheek-PCS1900-High	6
PCS1900-LeftHandSide-Cheek-High	6
4.16 RightHandSide-Cheek-PCS1900-Middle	6
PCS1900-RightHandSide-Cheek-Middle	6
4.17 RightHandSide-Tilt-PCS1900-Middle	6
PCS1900-RightHandSide-Tilt-Middle	6
4.18 RightHandSide-Cheek-PCS1900-Low	6
PCS1900-RightHandSide-Cheek-Low	6
4.19 RightHandSide-Cheek-PCS1900-High	6
PCS1900-RightHandSide-Cheek-High	6
4.20 Body-Worn-PCS1900-Low	6
PCS1900-Body-Worn-Low-2.0cm	6
4.21 Body-Worn-PCS1900-Middle	6
PCS1900-Body-Worn-Middle-2.0cm	6
4.22 Body-Worn-PCS1900-High	6
PCS1900-Body-Worn-High-2.0cm	6
Appendix	6
1. Photographs of Test Setup	6
2. Photographs of the EUT	6
3. Photographs of the battery	6
4. Photograph of the charger	6
5. Probe Calibration certificate	6
6. DAE Calibration certification	6
7. Dipole Calibration certification	6
8. Uncertainty analysis	6
9. Phantom description	6

1. General Information

1.1 Test Laboratory

GSM Lab
SGS-CSTC Standards Technical Services Co.Ltd Shanghai Branch
9F,the 3rd Building, No.889, Yishan Rd, Xuhui District, Shanghai, China
Zip code: 200233
Telephone: +86 (0) 21 6495 1616
Fax: +86 (0) 21 5450 0149
Internet: <http://www.cn.sgs.com>

1.2 Details of Applicant

Name: T&A Mobile phones
Address: 4/F, No.2966, Jinke Rd, Zhangjiang High-Tech Park,
Pudong Shanghai 201203. P. R. China

1.3 Description of EUT(s)

Brand name	ALCATEL	
Model No.	CGL7C	
Market Name	OT-E206A	
Serial No.	IMEI: 011324000001090	
Sample Status	Production	
Battery Type	BYD battery	T5001990AAAA-720mAh
Antenna Type	Inner Antenna	
Operation Mode	GSM850/PCS1900	
Modulation Mode	GMSK	
Frequency range	GSM850	Tx: 824~849 MHz
		Rx: 869~894 MHz
	PCS1900	Tx: 1850~1910 MHz
		Rx: 1930~1990 MHz
Maximum RF Conducted Power	GSM850: 32.2dBm, PCS1900: 29.2dBm	

1.4 Test Environment

Ambient temperature: 22.0° C

Tissue Simulating Liquid: 22° C

Relative Humidity: 45%~55%

1.5 Operation Configuration

Configuration 1: GSM 850, LeftHandSide Cheek & 15° Tilt Position

Configuration 2: GSM 850, RightHandSide Cheek & 15° Tilt Position

Configuration 3: GSM 850, GPRS,BodyWorn (2.0 cm between EUT and phantom)

Configuration 4: PCS 1900, LeftHandSide Cheek & 15° Tilt Position

Configuration 5: PCS 1900, RightHandSide Cheek & 15° Tilt Position

Configuration 6: PCS 1900, GPRS,BodyWorn (2.0 cm between EUT and phantom)

1.6 The SAR Measurement System

A photograph of the SAR measurement System is given in Fig. a.

This SAR Measurement System uses a Computer-controlled 3-D stepper motor system (Speag Dasy 4 professional system). A Model ES3DV3 3088 E-field probe is used to determine the internal electric fields. The SAR can be obtained from the equation $SAR = \sigma (|E_i|^2) / \rho$ where σ and ρ are the conductivity and mass density of the tissue-simulant.

The DASY4 system for performing compliance tests consists of the following items:

- ÿ A standard high precision 6-axis robot (Stabile RX family) with controller, teach pendant and software. An arm extension for accommodation the data acquisition electronics (DAE).
- ÿ A dosimetric probe, i.e., an isotropic E-field probe optimized and calibrated for usage in tissue simulating liquid. The probe is equipped with an optical surface detector system.
- ÿ A data acquisition electronics (DAE) which performs the signal amplification, signal multiplexing, AD-conversion, offset measurements, mechanical surface detection, collision detection, etc. The unit is battery powered with standard or rechargeable batteries. The signal is optically transmitted to the EOC.

- The Electro-optical converter (EOC) performs the conversion between optical and electrical of the signals for the digital communication to DAE and for the analog signal from the optical surface detection. The EOC is connected to the measurement server.

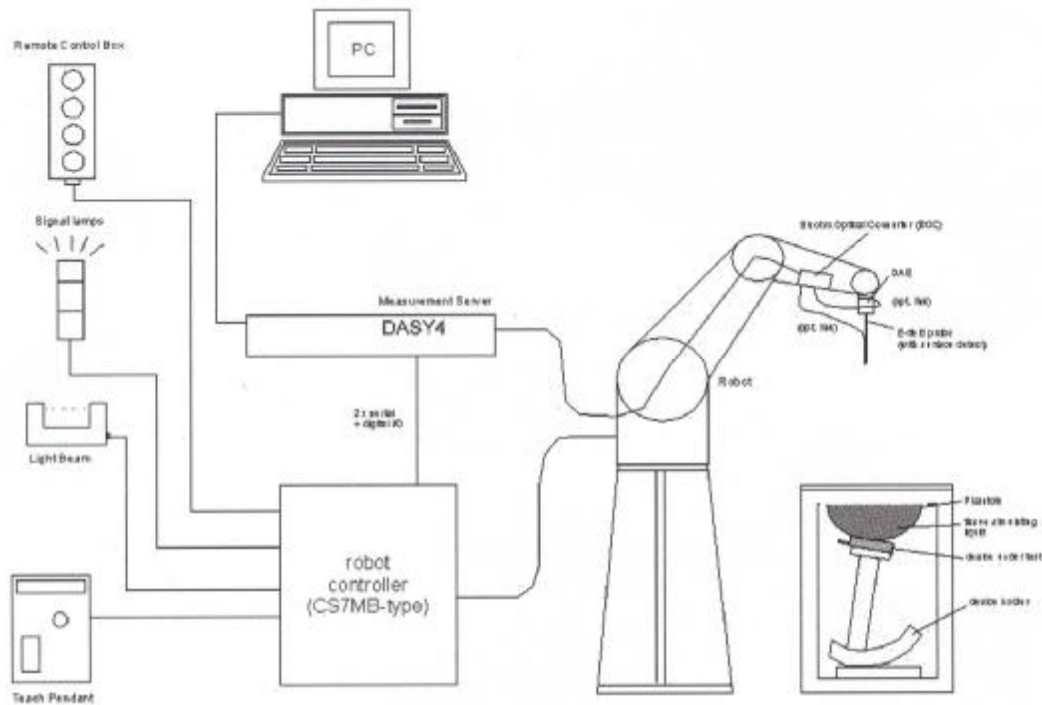

Fig. a SAR System Configuration

- The function of the measurement server is to perform the time critical tasks such as signal filtering, control of the robot operation and fast movement interrupts.
- A probe alignment unit which improves the (absolute) accuracy of the probe positioning.
- A computer operating Windows 2000.
- DASY4 software.
- Remote control with teach pendant and additional circuitry for robot safety such as warning lamps, etc.
- The SAM twin phantom enabling testing left-hand, right-hand and body-worn usage.
- The device holder for handheld mobile phones.
- Tissue simulating liquid mixed according to the given recipes.

• Validation dipole kits allowing to validating the proper functioning of the system.

1.7 SAR System Verification

The microwave circuit arrangement for system verification is sketched in Fig. b. The daily system accuracy verification occurs within the flat section of the SAM phantom. A SAR measurement was performed to see if the measured SAR was within +/- 10% from the target SAR values. These tests were done at 900MHz and 1900MHz. The tests were conducted on the same days as the measurement of the DUT. The obtained results from the system accuracy verification are displayed in the table 1 (SAR values are normalized to 1W forward power delivered to the dipole). During the tests, the ambient temperature of the laboratory was in the range 22°C, the relative humidity was in the range 60% and the liquid depth above the ear reference points was above 15 cm in all the cases. It is seen that the system is operating within its specification, as the results are within acceptable tolerance of the reference values.

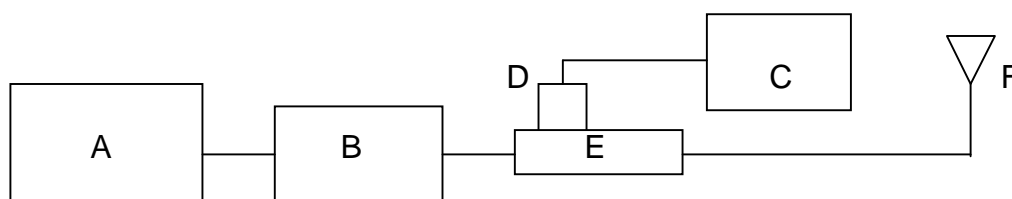

Fig. b the microwave circuit arrangement used for SAR system verification

- A. Agilent Model E4438C Signal Generator
- B. Mini-Circuit Model ZHL-42 Preamplifier
- C. Agilent Model E4416A Power Meter
- D. Agilent Model 8481H Power Sensor
- E. HT CP6100 20N Dual directional coupler
- F. Reference dipole antenna

Validation Kit	Frequency MHz	Target SAR 1g (250mW)	Target SAR 10g (250mW)	Measured SAR 1g	Measured SAR 10g	Measured Date
D900V2 SN184	900 Head	2.72	1.75	2.83	1.81	2007-08-24
D900V2 SN184	900 Body	2.75	1.79	2.71	1.74	2007-08-20
D1900V2 SN5d028	1900 Head	9.36	4.96	9.15	4.86	2007-08-27
D1900V2 SN5d028	1900 Body	9.5	5.05	9.64	5.11	2007-08-23

Table 1. Result System Validation

1.8 Tissue Simulant Fluid for the Frequency Band 850MHz and 1900MHZ

The dielectric properties for this body-simulant fluid were measured by using the HP Model 85070D Dielectric Probe (rates frequency band 200 MHz to 20 GHz) in conjunction with Agilent E5071B Network Analyzer (300 KHz-8500 MHz). The Conductivity (σ) and Permittivity (ρ) are listed in Table 2. For the SAR measurement given in this report. The temperature variation of the Tissue Simulant Fluid was 22°C.

Frequency (MHz)	Tissue Type	Limit/Measured	Permittivity (ρ)	Conductivity (σ)	Simulated Tissue Temp (°C)
850	Head	Recommended Limit	41.5±5%	0.90±5%	20-24
		Measured, 2007-08-24	41.8	0.87	22.5
	Body	Recommended Limit	55.2±5%	0.97±5%	20-24
		Measured, 2007-08-20	55.8	0.941	22.1
1900	Head	Recommended Limit	40.0±5%	1.40±5%	20-24
		Measured, 2007-08-27	39.17	1.441	22.1
	Body	Recommended Limit	53.3±5%	1.52±5%	20-24
		Measured, 2007-08-23	51.74	1.566	22.6

Table 2. Dielectric parameters for the Frequency Band 850MHz&1900MHZ

1.9 Test Standards and Limits

According to FCC 47 CFR §2.1093(d) the limits to be used for evaluation are based generally on criteria published by the American National Standards Institute (ANSI) for localized specific absorption rate (SAR) in Section 4.2 of "IEEE Standard for Safety Levels with Respect to Human Exposure to Radio Frequency Electromagnetic Fields, 3KHz to 300GHz," ANSI/IEEE C95.1-1992, Copyright 1992 by the Institute of Electrical & Electronics Engineers, Inc., New York, New York 10071.

Human Exposure	Uncontrolled Environment General Population
Spatial Peak SAR (Brain)	1.60 mW/g (averaged over a mass of 1g)

Table 3. RF Exposure Limits

Notes:

1. Uncontrolled environments are defined as locations where there is potential exposure of individuals who have no knowledge or control of their potential exposure.

2. Summary of Results

GSM850 SAR

Mode	Test Configuration		SAR, Averaged over 1g(W/kg)			Temperature (°C)	Verdict
	Channel/Power(dBm)		Low/31.5	Middle/31.5	High/31.5		
GSM850	Left	Cheek	1.16	1.1	0.835	22	Pass
		Tilt	-	0.685	-	22	Pass
	Right	Cheek	1.21	1.19	0.892	22	Pass
		Tilt	-	0.702	-	22	Pass
	Body	Distance 2.0 cm	0.748	0.554	0.334	22	Pass

PCS1900 SAR

Mode	Test Configuration		SAR, Averaged over 1g(W/kg)			Temperature (°C)	Verdict
	Channel/Power(dBm)		Low/28.9	Middle/28.8	High/29.1		
PCS1900	Left	Cheek	0.307	0.195	0.098	22	Pass
		Tilt	-	0.140	-	22	Pass
	Right	Cheek	0.297	0.181	0.098	22	Pass
		Tilt	-	0.116	-	22	Pass
	Body	Distance 2.0 cm	0.408	0.327	0.195	22	Pass

Maximum Values

Frequency Band(MHz)	EUT position	Output Power (dBm)	1g Average (W/Kg)	Power Drift (dB)	Temperature (°C)	Verdict
GSM850	LeftHandSide,Cheek,Low Channel	31.5	1.16	-0.115	22	PASS
	RightHandSide,Cheek, Low Channel	31.5	1.21	-0.047	22	PASS
	BodyWorn, Low Channel	31.5	0.748	-0.054	22	PASS
PCS1900	LeftHandSide,Cheek, Low Channel	28.9	0.307	0.013	22	PASS
	RightHandSide,Cheek, Low Channel	28.9	0.297	-0.040	22	PASS

	BodyWorn, Low Channel	28.9	0.408	0.044	22	PASS
--	-----------------------	-------------	--------------	--------------	-----------	-------------

Note:

1. In GSM850 band, the low, middle and high channels are CH128/824.2MHz, CH189/836.4MHz and CH251/848.8MHz separately.
2. In PCS1900 band, the low, middle and high channels are CH512/1805.2MHz, CH661/1880.0MHz and CH810/1909.8MHz separately.
3. For the Bodyworn measurements the sample was only placed with the antenna toward the phantom since this position delivers the highest SAR values.
4. For the Bodyworn measurements, the distance from the sample to the phantom is 2.0 cm.
5. For all the tests, the maximum absolute value of the power drift which is under the RightHandSide-Tilt-GSM850-Middle configuration is 0.153dB.

3. Instruments List

Instrument	Model	Serial number	NO.	Date of last Calibration
Desktop PC	COMPAQ EVO	N/A	GSM-SAR-025	N/A
Dasy 4 software	V 4.7 build 44	N/A	GSM-SAR-001	N/A
Probe	ES3DV3	3088	GSM-SAR-034	2006.12.12
DAE	DAE3	569	GSM-SAR-023	2006.12.08
900MHz system validation dipole	D900V2	184	GSM-SAR-017	2006.12.06
1900MHz system validation dipole	D1900V2	5d028	GSM-SAR-020	2006.12.12
Phantom	SAM 12	TP-1283	GSM-SAR-005	N/A
Robot	RX90L	F03/5V32A1/A01	GSM-SAR-028	N/A
Dielectric probe kit	85070D	US01440168	GSM-SAR-016	2006.12.19
Agilent network analyzer	E5071B	MY42100549	GSM-SAR-007	2006.12.19
Agilent signal generator	E4438	14438CATO-19719	GSM-SAR-008	2006.12.19
Mini-Circuits preamplifier	ZHL-42	D041905	GSM-SAR-033	2007.04.19
Agilent power meter	E4416A	GB41292095	GSM-SAR-010	2006.12.19
Agilent power sensor	8481H	MY41091234	GSM-SAR-011	2006.12.19
HT CP6100 20N Coupling	6100	SCP301480120	GSM-SAR-012	2006.12.19
R&S Universal radio communication tester	CMU200	103633	GSM-AUD-002	2006.12.19

4. Measurements

4.1 LeftHandSide-Cheek-GSM850-Middle

Date/Time: 2007-8-24 11:03:16

Test Laboratory: SGS-GSM

GSM850-LeftHandSide-Cheek-Middle

DUT: GSM10528201; Type: Body; Serial: 1#

Communication System: GSM850-GSM Mode; Frequency: 836.4 MHz; Duty Cycle: 1:8.3

Medium: HSL850-Head Medium parameters used: $f = 836.4$ MHz; $\sigma = 0.873$ mho/m; $\epsilon_r = 43.5$; $\rho = 1000$ kg/m³

Phantom section: Left Section

DASY4 Configuration:

- Probe: ES3DV3 - SN3088; ConvF(6, 6, 6); Calibrated: 2006-12-12
- Sensor-Surface: 4mm (Mechanical Surface Detection)
- Electronics: DAE3 Sn569; Calibrated: 2006-12-8
- Phantom: SAM 12; Type: SAM V4.0; Serial: TP-1283
- Measurement SW: DASY4, V4.7 Build 44; Postprocessing SW: SEMCAD, V1.8 Build 171

Cheek position - Mid/Area Scan (61x101x1): Measurement grid: dx=15mm, dy=15mm

Maximum value of SAR (interpolated) = 1.18 mW/g

Cheek position - Mid/Zoom Scan (7x7x7) (7x7x7)/Cube 0: Measurement grid: dx=5mm, dy=5mm, dz=5mm

Reference Value = 30.5 V/m; Power Drift = -0.012 dB

Peak SAR (extrapolated) = 1.49 W/kg

SAR(1 g) = 1.1 mW/g; SAR(10 g) = 0.755 mW/g

Maximum value of SAR (measured) = 1.18 mW/g

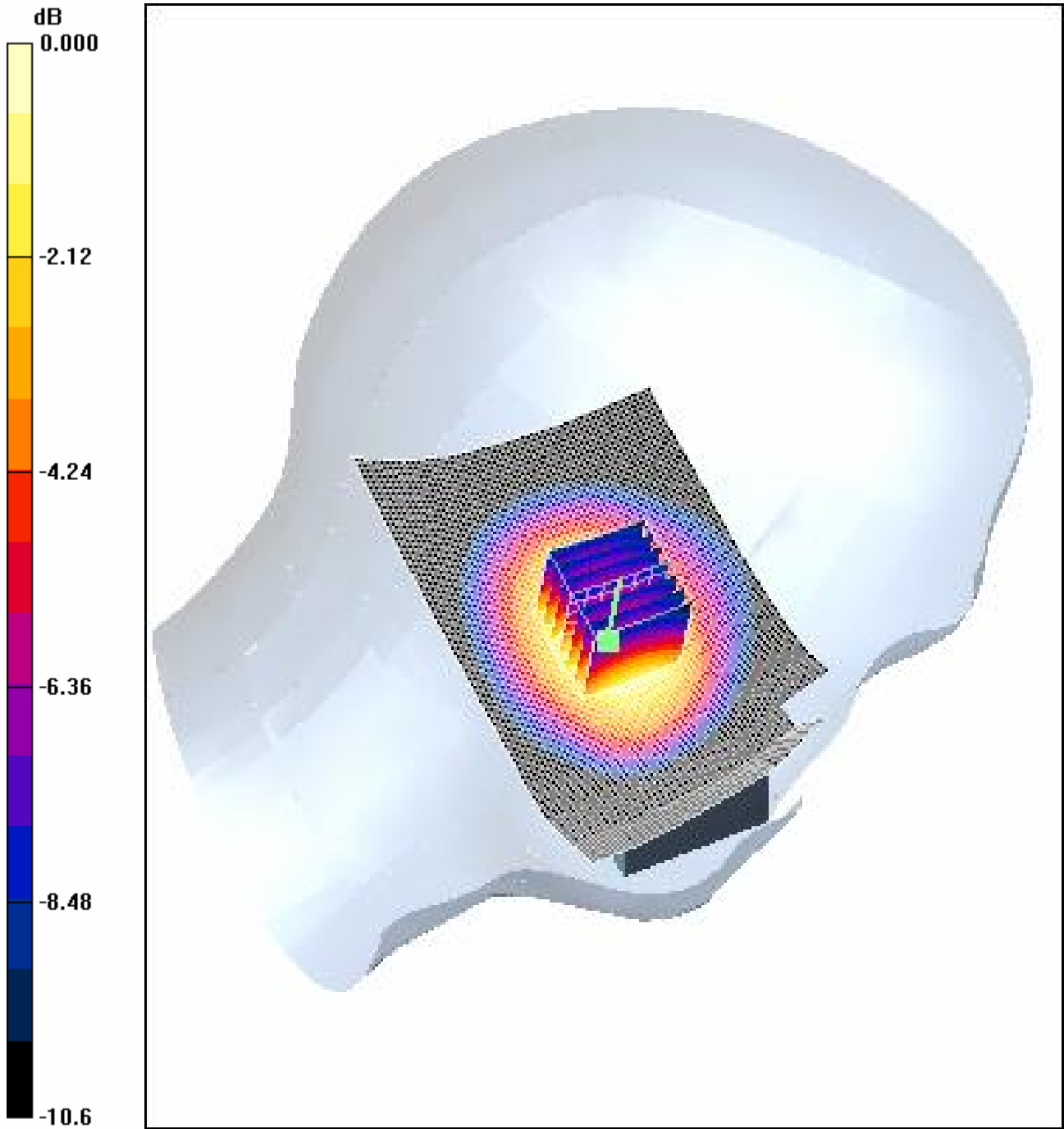

0 dB = 1.18mW/g

4.2 LeftHandSide-Tilt-GSM850-Middle

Date/Time: 2007-8-24 13:36:39

Test Laboratory: SGS-GSM

GSM850-LeftHandSide-Tilt-Middle

DUT: GSM10528201; Type: Body; Serial: 1#

Communication System: GSM850-GSM Mode; Frequency: 836.4 MHz; Duty Cycle: 1:8.3

Medium: HSL850-Head Medium parameters used: $f = 836.4$ MHz; $\sigma = 0.873$ mho/m; $\epsilon_r = 43.5$; $\rho = 1000$ kg/m³

Phantom section: Left Section

DASY4 Configuration:

- Probe: ES3DV3 - SN3088; ConvF(6, 6, 6); Calibrated: 2006-12-12
- Sensor-Surface: 4mm (Mechanical Surface Detection)
- Electronics: DAE3 Sn569; Calibrated: 2006-12-8
- Phantom: SAM 12; Type: SAM V4.0; Serial: TP-1283
- Measurement SW: DASY4, V4.7 Build 44; Postprocessing SW: SEMCAD, V1.8 Build 171

Tilt position - Mid/Area Scan (61x101x1): Measurement grid: dx=15mm, dy=15mm

Maximum value of SAR (interpolated) = 0.747 mW/g

Tilt position - Mid/Zoom Scan (7x7x7) (7x7x7)/Cube 0: Measurement grid: dx=5mm, dy=5mm, dz=5mm

Reference Value = 28.3 V/m; Power Drift = -0.149 dB

Peak SAR (extrapolated) = 0.925 W/kg

SAR(1 g) = 0.685 mW/g; SAR(10 g) = 0.472 mW/g

Maximum value of SAR (measured) = 0.734 mW/g

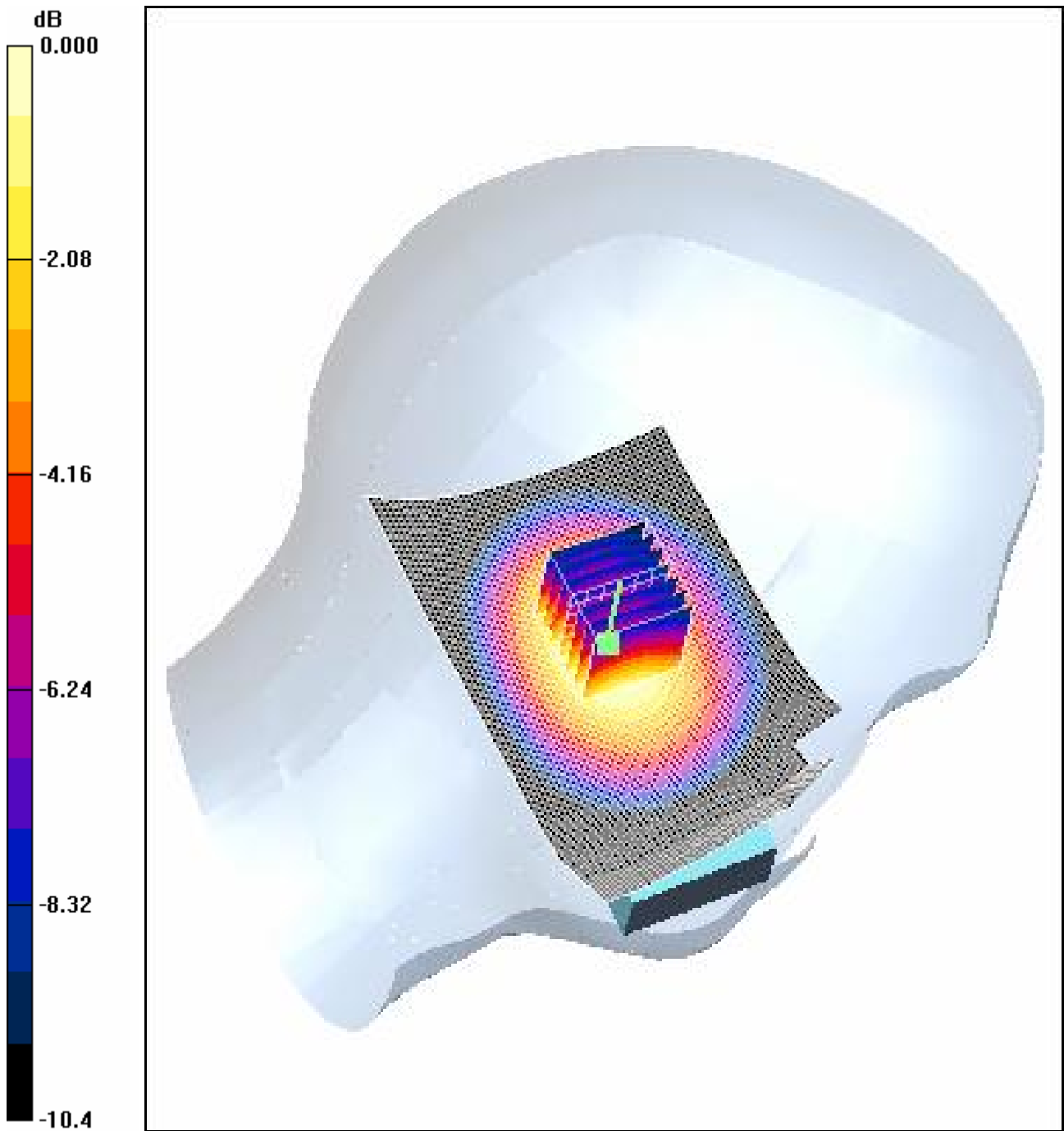

0 dB = 0.734mW/g

4.3LeftHandSide-Cheek-GSM850-Low

Date/Time: 2007-8-24 11:28:09

Test Laboratory: SGS-GSM

GSM850-LeftHandSide-Cheek-Low

DUT: GSM10528201; Type: Body; Serial: 1#

Communication System: GSM850-GSM Mode; Frequency: 824.2 MHz; Duty Cycle: 1:8.3

Medium: HSL850-Head Medium parameters used: $f = 824.2$ MHz; $\sigma = 0.86$ mho/m; $\epsilon_r = 43.5$; $\rho = 1000$ kg/m³

Phantom section: Left Section

DASY4 Configuration:

- Probe: ES3DV3 - SN3088; ConvF(6, 6, 6); Calibrated: 2006-12-12
- Sensor-Surface: 4mm (Mechanical Surface Detection)
- Electronics: DAE3 Sn569; Calibrated: 2006-12-8
- Phantom: SAM 12; Type: SAM V4.0; Serial: TP-1283
- Measurement SW: DASY4, V4.7 Build 44; Postprocessing SW: SEMCAD, V1.8 Build 171

Cheek position - Low/Area Scan (61x91x1): Measurement grid: dx=15mm, dy=15mm

Maximum value of SAR (interpolated) = 1.24 mW/g

Cheek position - Low/Zoom Scan (7x7x7)/Cube 0: Measurement grid: dx=5mm, dy=5mm, dz=5mm

Reference Value = 32.1 V/m; Power Drift = -0.115 dB

Peak SAR (extrapolated) = 1.58 W/kg

SAR(1 g) = 1.16 mW/g; SAR(10 g) = 0.799 mW/g

Maximum value of SAR (measured) = 1.25 mW/g

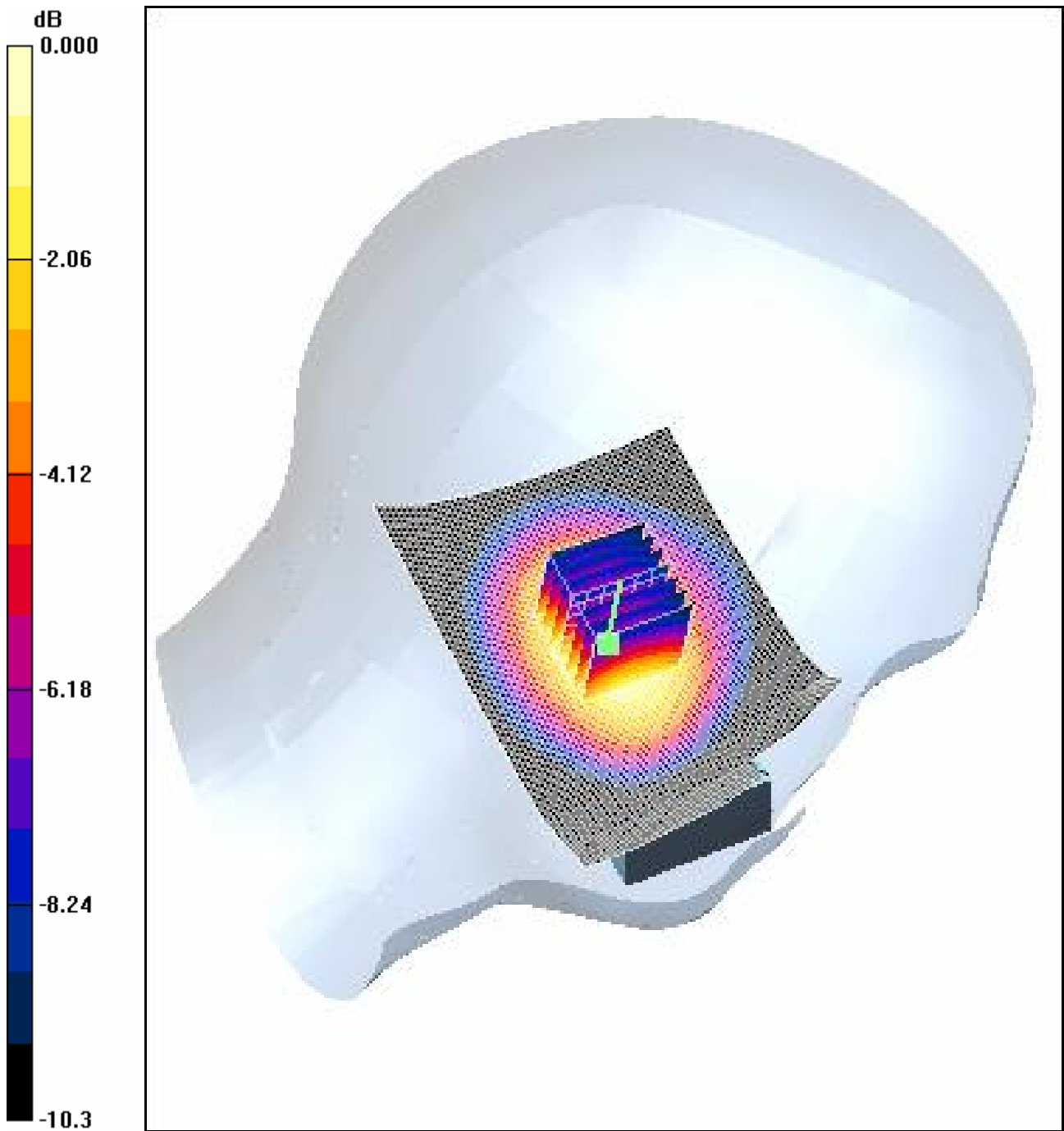

0 dB = 1.25mW/g

4.4LeftHandSide-Cheek-GSM850-High

Date/Time: 2007-8-24 12:16:14

Test Laboratory: SGS-GSM

GSM850-LeftHandSide-Cheek-High

DUT: GSM10528201; Type: Body; Serial: 1#

Communication System: GSM850-GSM Mode; Frequency: 848.8 MHz; Duty Cycle: 1:8.3

Medium: HSL850-Head Medium parameters used: $f = 848.8$ MHz; $\sigma = 0.887$ mho/m; $\epsilon_r = 43.4$; $\rho = 1000$ kg/m³

Phantom section: Left Section

DASY4 Configuration:

- Probe: ES3DV3 - SN3088; ConvF(6, 6, 6); Calibrated: 2006-12-12
- Sensor-Surface: 4mm (Mechanical Surface Detection)
- Electronics: DAE3 Sn569; Calibrated: 2006-12-8
- Phantom: SAM 12; Type: SAM V4.0; Serial: TP-1283
- Measurement SW: DASY4, V4.7 Build 44; Postprocessing SW: SEMCAD, V1.8 Build 171

Cheek position - High/Area Scan (61x101x1): Measurement grid: dx=15mm, dy=15mm

Maximum value of SAR (interpolated) = 0.894 mW/g

Cheek position - High/Zoom Scan (7x7x7) (7x7x7)/Cube 0: Measurement grid: dx=5mm, dy=5mm, dz=5mm

Reference Value = 26.4 V/m; Power Drift = -0.054 dB

Peak SAR (extrapolated) = 1.11 W/kg

SAR(1 g) = 0.835 mW/g; SAR(10 g) = 0.573 mW/g

Maximum value of SAR (measured) = 0.898 mW/g

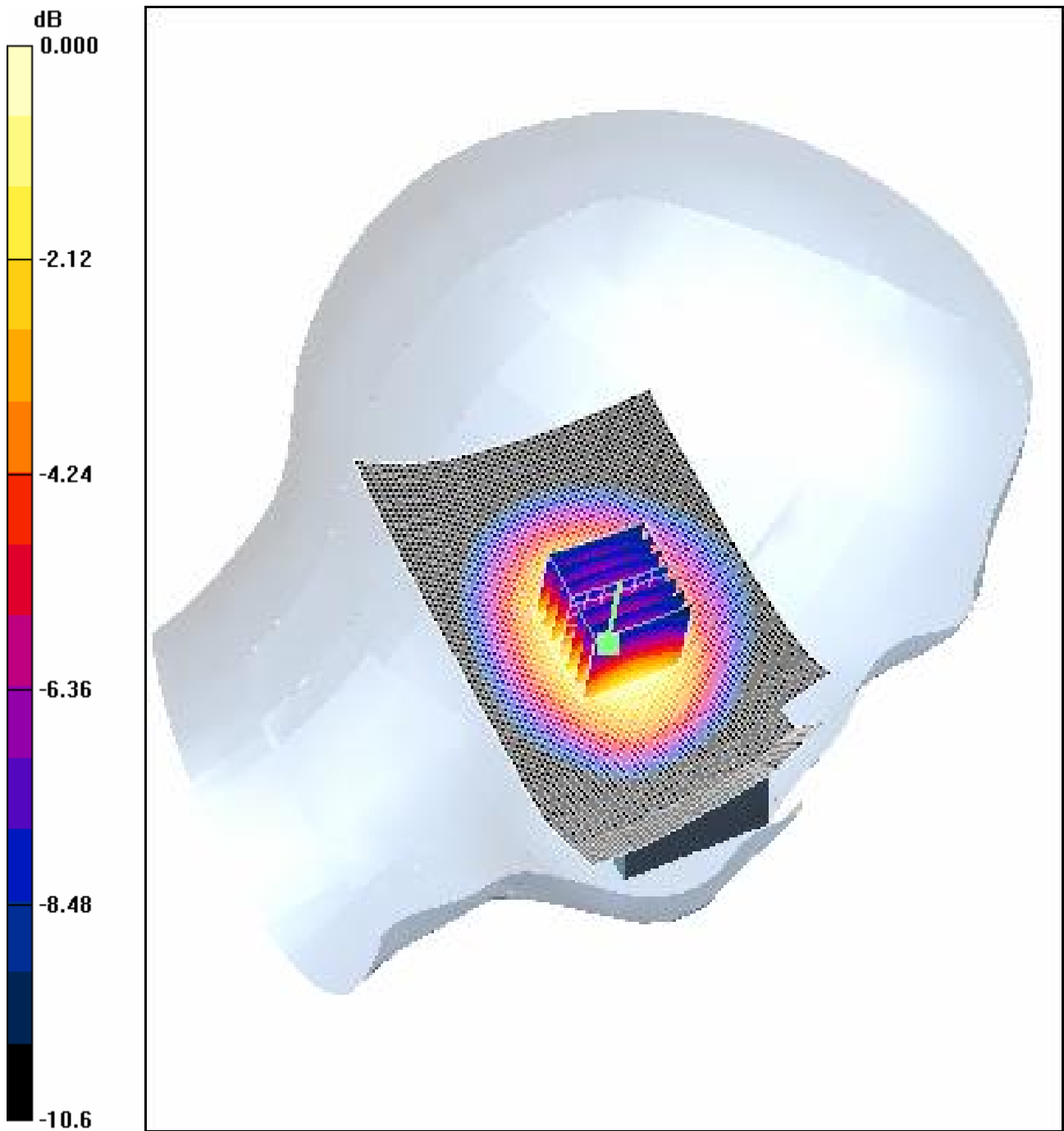

0 dB = 0.898mW/g

4.5RightHandSide-Cheek-GSM850-Middle

Date/Time: 2007-8-24 14:28:51

Test Laboratory: SGS-GSM

GSM850-RightHandSide-Cheek-Middle

DUT: GSM10528201; Type: Body; Serial: 1#

Communication System: GSM850-GSM Mode; Frequency: 836.4 MHz; Duty Cycle: 1:8.3

Medium: HSL850-Head Medium parameters used: $f = 836.4$ MHz; $\sigma = 0.873$ mho/m; $\epsilon_r = 43.5$; $\rho = 1000$ kg/m³

Phantom section: Right Section

DASY4 Configuration:

- Probe: ES3DV3 - SN3088; ConvF(6, 6, 6); Calibrated: 2006-12-12
- Sensor-Surface: 4mm (Mechanical Surface Detection)
- Electronics: DAE3 Sn569; Calibrated: 2006-12-8
- Phantom: SAM 12; Type: SAM V4.0; Serial: TP-1283
- Measurement SW: DASY4, V4.7 Build 44; Postprocessing SW: SEMCAD, V1.8 Build 171

Cheek position - Middle/Area Scan (61x101x1): Measurement grid: dx=15mm, dy=15mm
Maximum value of SAR (interpolated) = 1.30 mW/g

Cheek position - Middle/Zoom Scan (7x7x7)/Cube 0: Measurement grid: dx=5mm, dy=5mm,
dz=5mm

Reference Value = 27.5 V/m; Power Drift = -0.135 dB

Peak SAR (extrapolated) = 1.58 W/kg

SAR(1 g) = 1.19 mW/g; SAR(10 g) = 0.824 mW/g

Maximum value of SAR (measured) = 1.28 mW/g

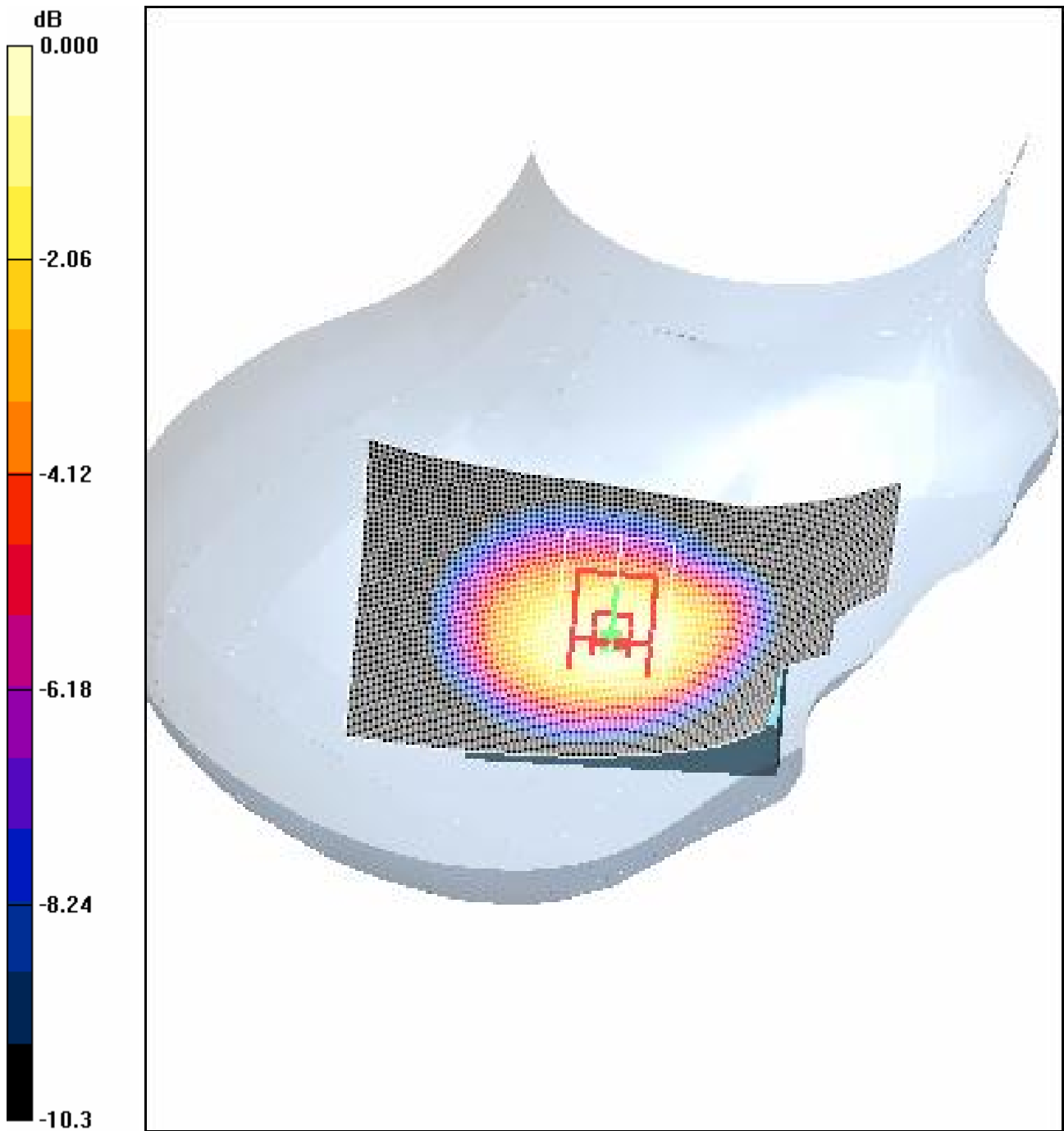

0 dB = 1.28mW/g

4.6RightHandSide-Tilt-GSM850-Middle

Date/Time: 2007-8-24 14:54:44

Test Laboratory: SGS-GSM

GSM850-RightHandSide-Tilt-Middle

DUT: GSM10528201; Type: Body; Serial: 1#

Communication System: GSM850-GSM Mode; Frequency: 836.4 MHz; Duty Cycle: 1:8.3

Medium: HSL850-Head Medium parameters used: $f = 836.4$ MHz; $\sigma = 0.873$ mho/m; $\epsilon_r = 43.5$; $\rho = 1000$ kg/m³

Phantom section: Right Section

DASY4 Configuration:

- Probe: ES3DV3 - SN3088; ConvF(6, 6, 6); Calibrated: 2006-12-12
- Sensor-Surface: 4mm (Mechanical Surface Detection)
- Electronics: DAE3 Sn569; Calibrated: 2006-12-8
- Phantom: SAM 12; Type: SAM V4.0; Serial: TP-1283
- Measurement SW: DASY4, V4.7 Build 44; Postprocessing SW: SEMCAD, V1.8 Build 171

Tilt position - Middle/Area Scan (61x101x1): Measurement grid: dx=15mm, dy=15mm

Maximum value of SAR (interpolated) = 0.751 mW/g

Tilt position - Middle/Zoom Scan (7x7x7)/Cube 0: Measurement grid: dx=5mm, dy=5mm, dz=5mm

Reference Value = 25.6 V/m; Power Drift = -0.153 dB

Peak SAR (extrapolated) = 0.937 W/kg

SAR(1 g) = 0.702 mW/g; SAR(10 g) = 0.488 mW/g

Maximum value of SAR (measured) = 0.752 mW/g

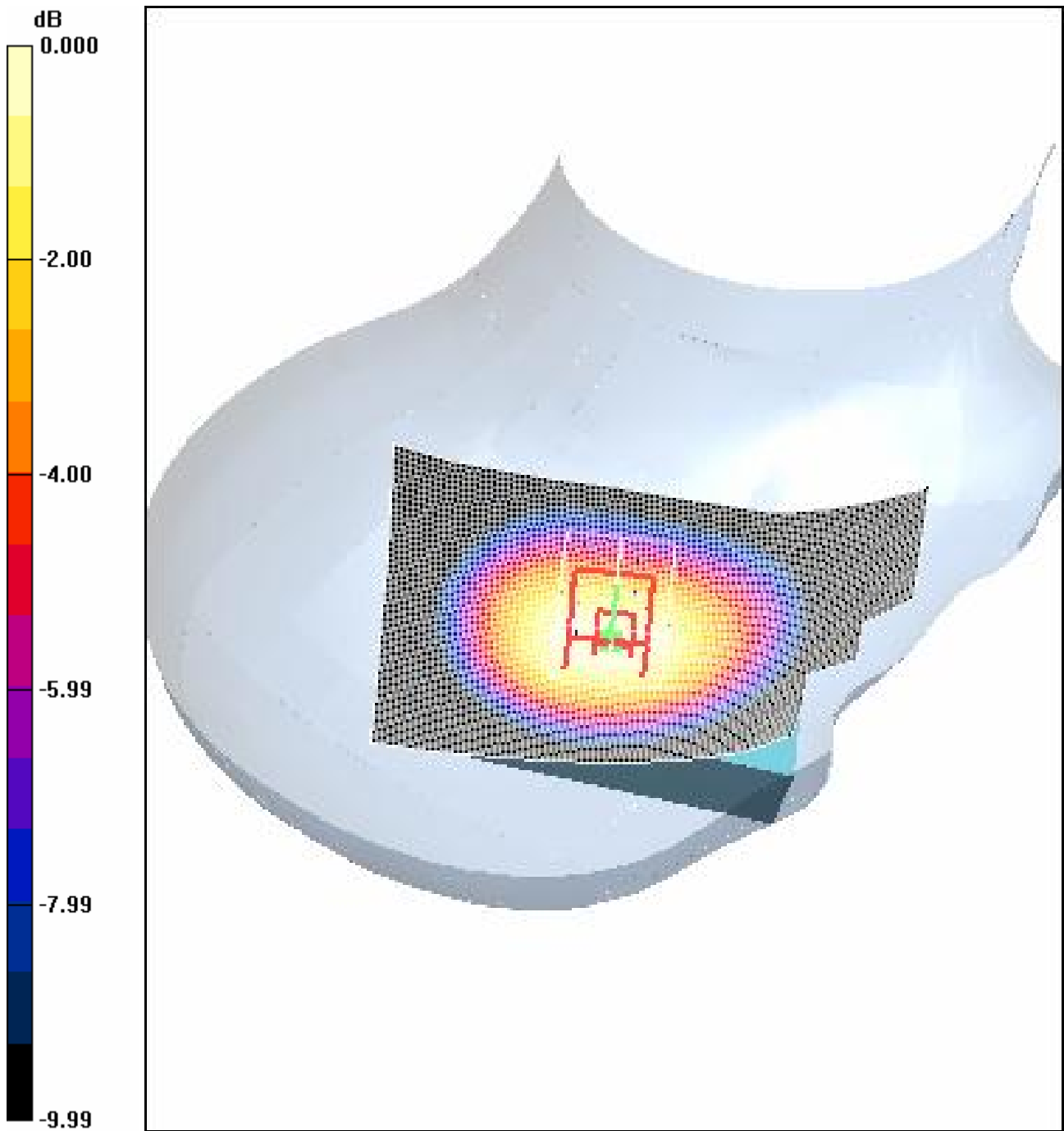

0 dB = 0.752mW/g

4.7RightHandSide-Cheek-GSM850-Low

Date/Time: 2007-8-24 15:18:57

Test Laboratory: SGS-GSM

GSM850-RightHandSide-Cheek-Low

DUT: GSM10528201; Type: Body; Serial: 1#

Communication System: GSM850-GSM Mode; Frequency: 824.2 MHz; Duty Cycle: 1:8.3

Medium: HSL850-Head Medium parameters used: $f = 824.2$ MHz; $\sigma = 0.86$ mho/m; $\epsilon_r = 43.5$; $\rho = 1000$ kg/m³

Phantom section: Right Section

DASY4 Configuration:

- Probe: ES3DV3 - SN3088; ConvF(6, 6, 6); Calibrated: 2006-12-12
- Sensor-Surface: 4mm (Mechanical Surface Detection)
- Electronics: DAE3 Sn569; Calibrated: 2006-12-8
- Phantom: SAM 12; Type: SAM V4.0; Serial: TP-1283
- Measurement SW: DASY4, V4.7 Build 44; Postprocessing SW: SEMCAD, V1.8 Build 171

Cheek position - Low/Area Scan (61x101x1): Measurement grid: dx=15mm, dy=15mm

Maximum value of SAR (interpolated) = 1.31 mW/g

Cheek position - Low/Zoom Scan (7x7x7) (7x7x7)/Cube 0: Measurement grid: dx=5mm, dy=5mm, dz=5mm

Reference Value = 28.1 V/m; Power Drift = -0.047 dB

Peak SAR (extrapolated) = 1.60 W/kg

SAR(1 g) = 1.21 mW/g; SAR(10 g) = 0.840 mW/g

Maximum value of SAR (measured) = 1.31 mW/g

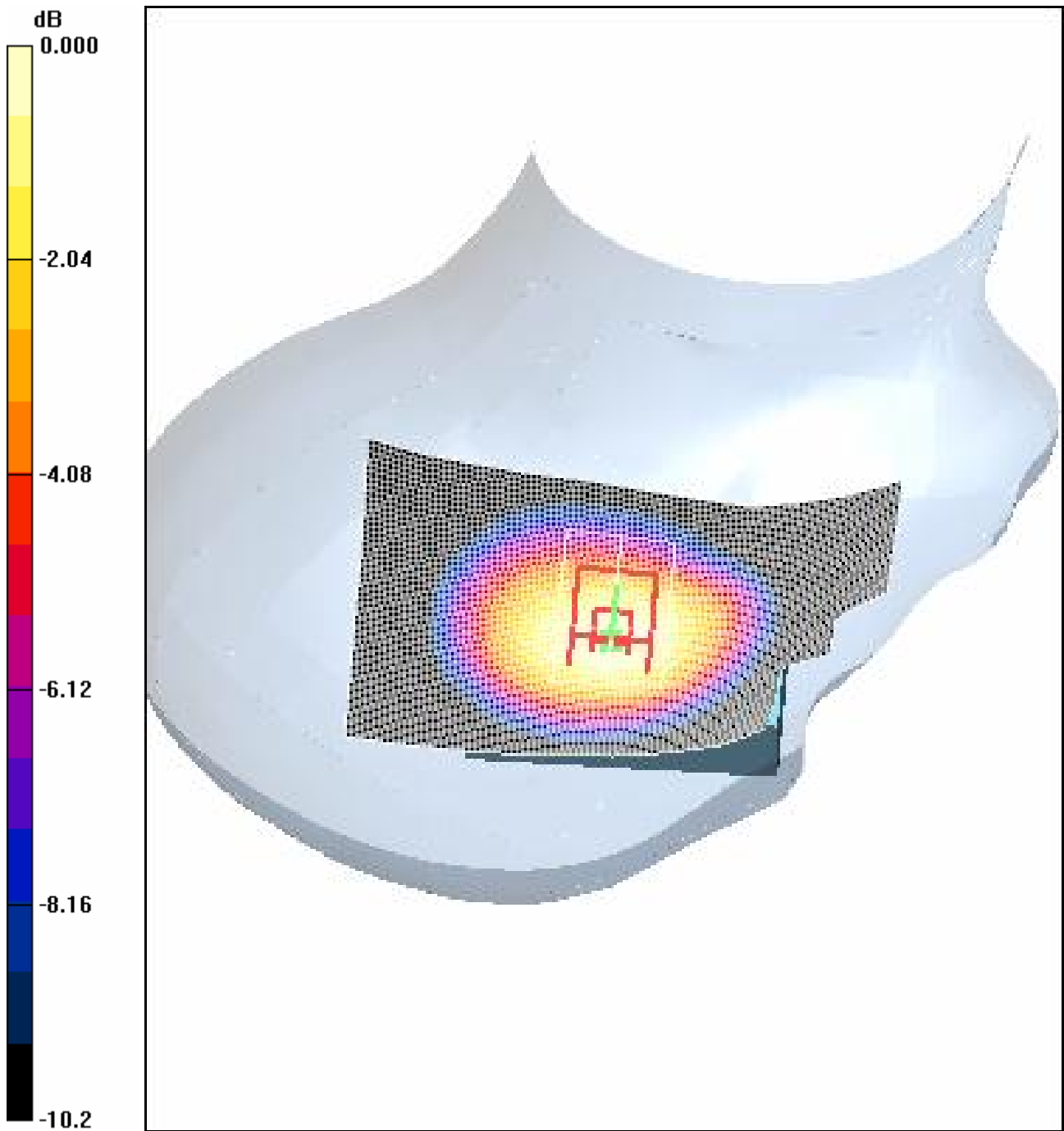

0 dB = 1.31mW/g

4.8RightHandSide-Cheek-GSM850-High

Date/Time: 2007-8-24 14:04:06

Test Laboratory: SGS-GSM

GSM850-RightHandSide-Cheek-High

DUT: GSM10528201; Type: Body; Serial: 1#

Communication System: GSM850-GSM Mode; Frequency: 848.8 MHz; Duty Cycle: 1:8.3

Medium: HSL850-Head Medium parameters used: $f = 848.8$ MHz; $\sigma = 0.887$ mho/m; $\epsilon_r = 43.4$; $\rho = 1000$ kg/m³

Phantom section: Right Section

DASY4 Configuration:

- Probe: ES3DV3 - SN3088; ConvF(6, 6, 6); Calibrated: 2006-12-12
- Sensor-Surface: 4mm (Mechanical Surface Detection)
- Electronics: DAE3 Sn569; Calibrated: 2006-12-8
- Phantom: SAM 12; Type: SAM V4.0; Serial: TP-1283
- Measurement SW: DASY4, V4.7 Build 44; Postprocessing SW: SEMCAD, V1.8 Build 171

Cheek position - High/Area Scan (61x101x1): Measurement grid: dx=15mm, dy=15mm

Maximum value of SAR (interpolated) = 0.957 mW/g

Cheek position - High/Zoom Scan (7x7x7) (7x7x7)/Cube 0: Measurement grid: dx=5mm, dy=5mm, dz=5mm

Reference Value = 23.1 V/m; Power Drift = -0.038 dB

Peak SAR (extrapolated) = 1.18 W/kg

SAR(1 g) = 0.892 mW/g; SAR(10 g) = 0.613 mW/g

Maximum value of SAR (measured) = 0.962 mW/g

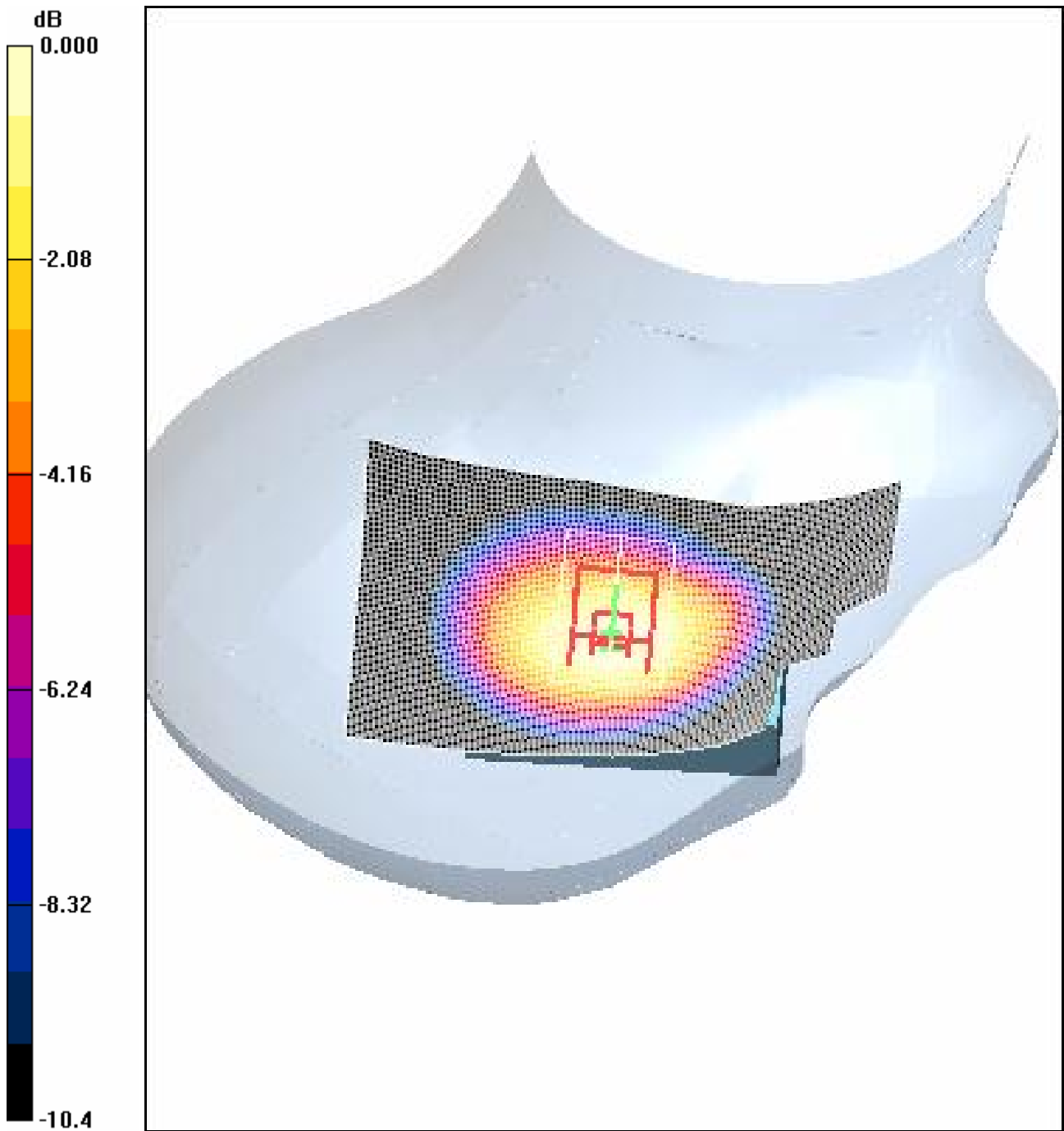

0 dB = 0.962mW/g

4.9Body-Worn-GSM850-Low

Date/Time: 2007-8-20 11:10:42

Test Laboratory: SGS-GSM

GSM850-Body-Worn-Low-2.0cm

DUT: GSM10528201; Type: Body; Serial: 1#

Communication System: GSM850-GSM Mode; Frequency: 824.2 MHz; Duty Cycle: 1:8.3

Medium: 850-Body Medium parameters used: $f = 824.2$ MHz; $\sigma = 0.952$ mho/m; $\epsilon_r = 54.7$; $\rho = 1000$ kg/m³

Phantom section: Flat Section

DASY4 Configuration:

- Probe: ES3DV3 - SN3088; ConvF(5.92, 5.92, 5.92); Calibrated: 2006-12-12
- Sensor-Surface: 4mm (Mechanical Surface Detection)
- Electronics: DAE3 Sn569; Calibrated: 2006-12-8
- Phantom: SAM 12; Type: SAM V4.0; Serial: TP-1283
- Measurement SW: DASY4, V4.7 Build 44; Postprocessing SW: SEMCAD, V1.8 Build 171

Body Worn - Low/Area Scan (51x91x1): Measurement grid: dx=15mm, dy=15mm

Maximum value of SAR (interpolated) = 0.816 mW/g

Body Worn - Low/Zoom Scan (7x7x7) (7x7x7)/Cube 0: Measurement grid: dx=5mm, dy=5mm, dz=5mm

Reference Value = 16.9 V/m; Power Drift = -0.054 dB

Peak SAR (extrapolated) = 1.05 W/kg

SAR(1 g) = 0.748 mW/g; SAR(10 g) = 0.515 mW/g

Maximum value of SAR (measured) = 0.797 mW/g

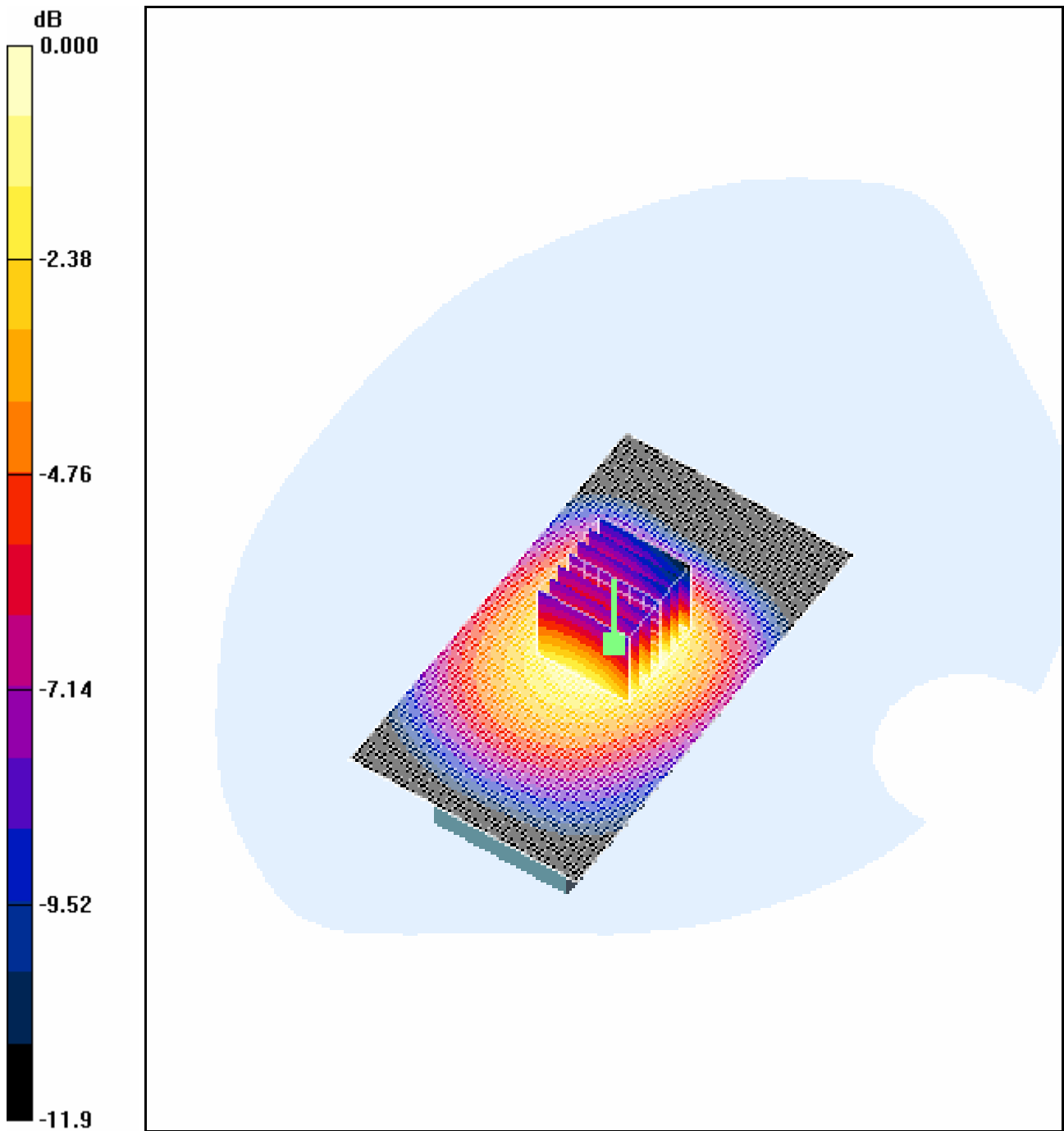

0 dB = 0.797mW/g

4.10Body-Worn-GSM850-Middle

Date/Time: 2007-8-20 10:49:13

Test Laboratory: SGS-GSM

GSM850-Body-Worn-Middle-2.0cm

DUT: GSM10528201; Type: Body; Serial: 1#

Communication System: GSM850-GSM Mode; Frequency: 836.4 MHz; Duty Cycle: 1:8.3

Medium: 850-Body Medium parameters used: $f = 836.4$ MHz; $\sigma = 0.964$ mho/m; $\epsilon_r = 54.9$; $\rho = 1000$ kg/m³

Phantom section: Flat Section

DASY4 Configuration:

- Probe: ES3DV3 - SN3088; ConvF(5.92, 5.92, 5.92); Calibrated: 2006-12-12
- Sensor-Surface: 4mm (Mechanical Surface Detection)
- Electronics: DAE3 Sn569; Calibrated: 2006-12-8
- Phantom: SAM 12; Type: SAM V4.0; Serial: TP-1283
- Measurement SW: DASY4, V4.7 Build 44; Postprocessing SW: SEMCAD, V1.8 Build 171

Body Worn - Middle/Area Scan (51x91x1): Measurement grid: dx=15mm, dy=15mm

Maximum value of SAR (interpolated) = 0.606 mW/g

Body Worn - Middle/Zoom Scan (7x7x7)/Cube 0: Measurement grid: dx=5mm, dy=5mm, dz=5mm

Reference Value = 14.5 V/m; Power Drift = -0.033 dB

Peak SAR (extrapolated) = 0.776 W/kg

SAR(1 g) = 0.554 mW/g; SAR(10 g) = 0.381 mW/g

Maximum value of SAR (measured) = 0.593 mW/g

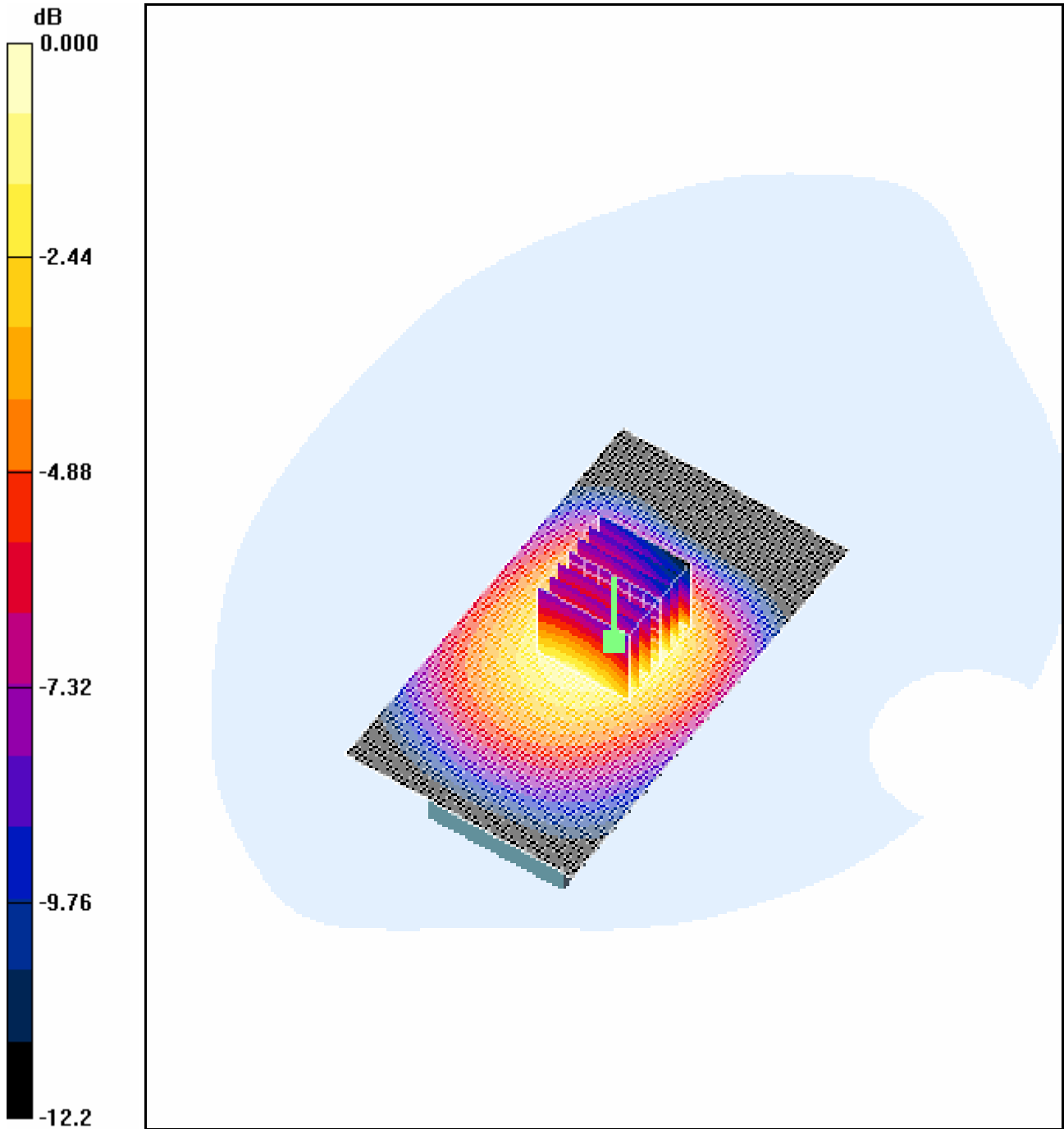

0 dB = 0.593mW/g

4.11 Body-Worn-GSM850-High

Date/Time: 2007-8-20 11:45:48

Test Laboratory: SGS-GSM

GSM850-Body-Worn-High-2.0cm

DUT: GSM10528201; Type: Body; Serial: 1#

Communication System: GSM850-GSM Mode; Frequency: 848.8 MHz; Duty Cycle: 1:8.3

Medium: 850-Body Medium parameters used: $f = 848.8$ MHz; $\sigma = 0.972$ mho/m; $\epsilon_r = 54.8$; $\rho = 1000$ kg/m³

Phantom section: Flat Section

DASY4 Configuration:

- Probe: ES3DV3 - SN3088; ConvF(5.92, 5.92, 5.92); Calibrated: 2006-12-12
- Sensor-Surface: 4mm (Mechanical Surface Detection)
- Electronics: DAE3 Sn569; Calibrated: 2006-12-8
- Phantom: SAM 12; Type: SAM V4.0; Serial: TP-1283
- Measurement SW: DASY4, V4.7 Build 44; Postprocessing SW: SEMCAD, V1.8 Build 171

Body Worn - High/Area Scan (51x91x1): Measurement grid: dx=15mm, dy=15mm

Maximum value of SAR (interpolated) = 0.364 mW/g

Body Worn - High/Zoom Scan (7x7x7) (7x7x7)/Cube 0: Measurement grid: dx=5mm, dy=5mm, dz=5mm

Reference Value = 11.2 V/m; Power Drift = 0.016 dB

Peak SAR (extrapolated) = 0.469 W/kg

SAR(1 g) = 0.334 mW/g; SAR(10 g) = 0.230 mW/g

Maximum value of SAR (measured) = 0.357 mW/g

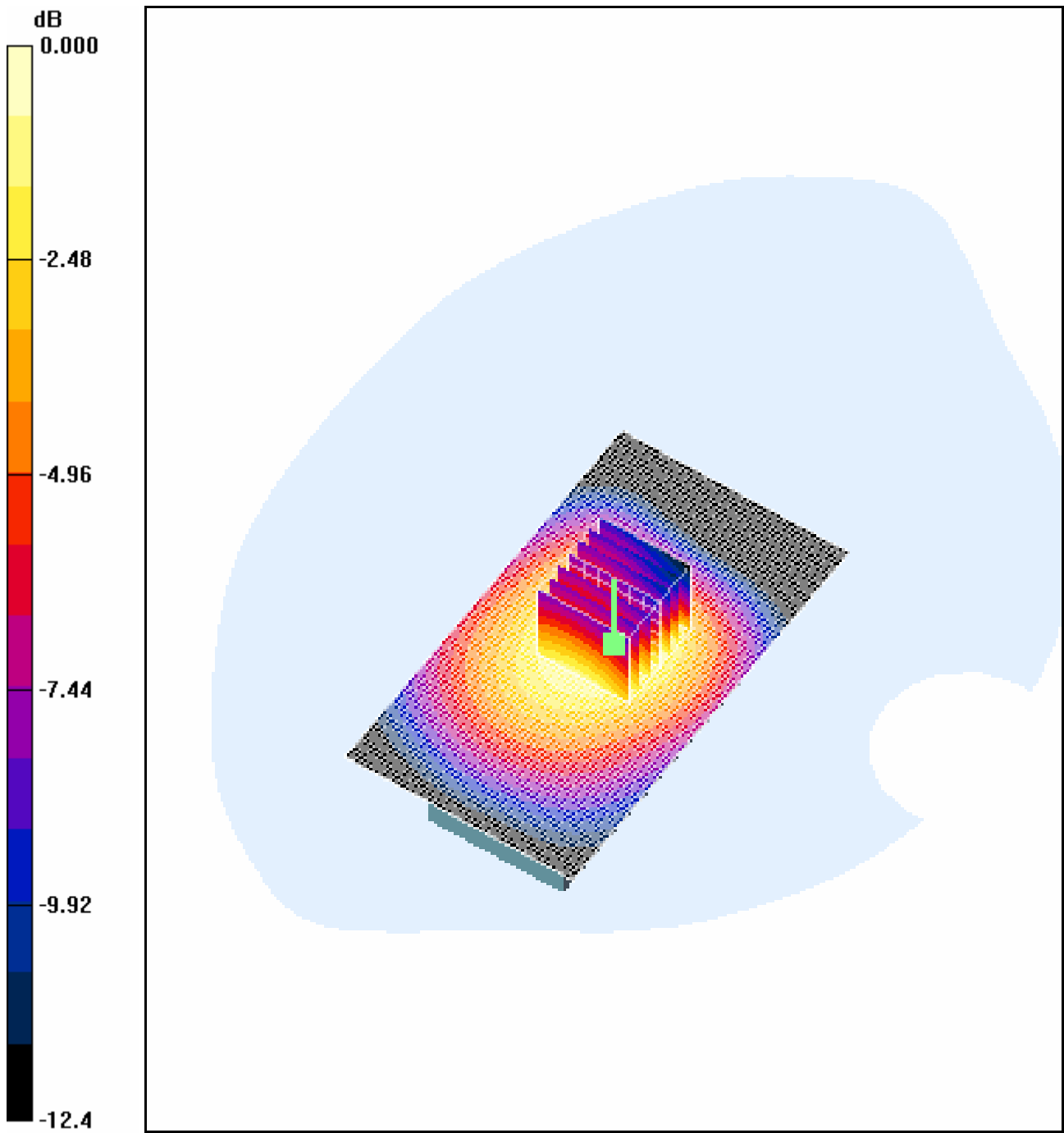

0 dB = 0.357mW/g

4.12LeftHandSide-Cheek-PCS1900-Middle

Date/Time: 2007-8-27 19:03:25

Test Laboratory: SGS-GSM

PCS1900-LeftHandSide-Cheek-Middle

DUT: GSM10528201; Type: Body; Serial: 1#

Communication System: PCS1900-GSM Mode; Frequency: 1880 MHz; Duty Cycle: 1:8.3

Medium: HSL1900_Head Medium parameters used: $f = 1880$ MHz; $\sigma = 1.42$ mho/m; $\epsilon_r = 39.8$; $\rho = 1000$ kg/m³

Phantom section: Left Section

DASY4 Configuration:

- Probe: ES3DV3 - SN3088; ConvF(5.07, 5.07, 5.07); Calibrated: 2006-12-12
- Sensor-Surface: 4mm (Mechanical Surface Detection)
- Electronics: DAE3 Sn569; Calibrated: 2006-12-8
- Phantom: SAM 12; Type: SAM V4.0; Serial: TP-1283
- Measurement SW: DASY4, V4.7 Build 44; Postprocessing SW: SEMCAD, V1.8 Build 171

Cheek position - Middle/Area Scan (61x101x1): Measurement grid: dx=15mm, dy=15mm
Maximum value of SAR (interpolated) = 0.218 mW/g

Cheek position - Middle/Zoom Scan (7x7x7)/Cube 0: Measurement grid: dx=5mm, dy=5mm,
dz=5mm

Reference Value = 8.87 V/m; Power Drift = -0.078 dB

Peak SAR (extrapolated) = 0.277 W/kg

SAR(1 g) = 0.195 mW/g; SAR(10 g) = 0.116 mW/g

Maximum value of SAR (measured) = 0.215 mW/g

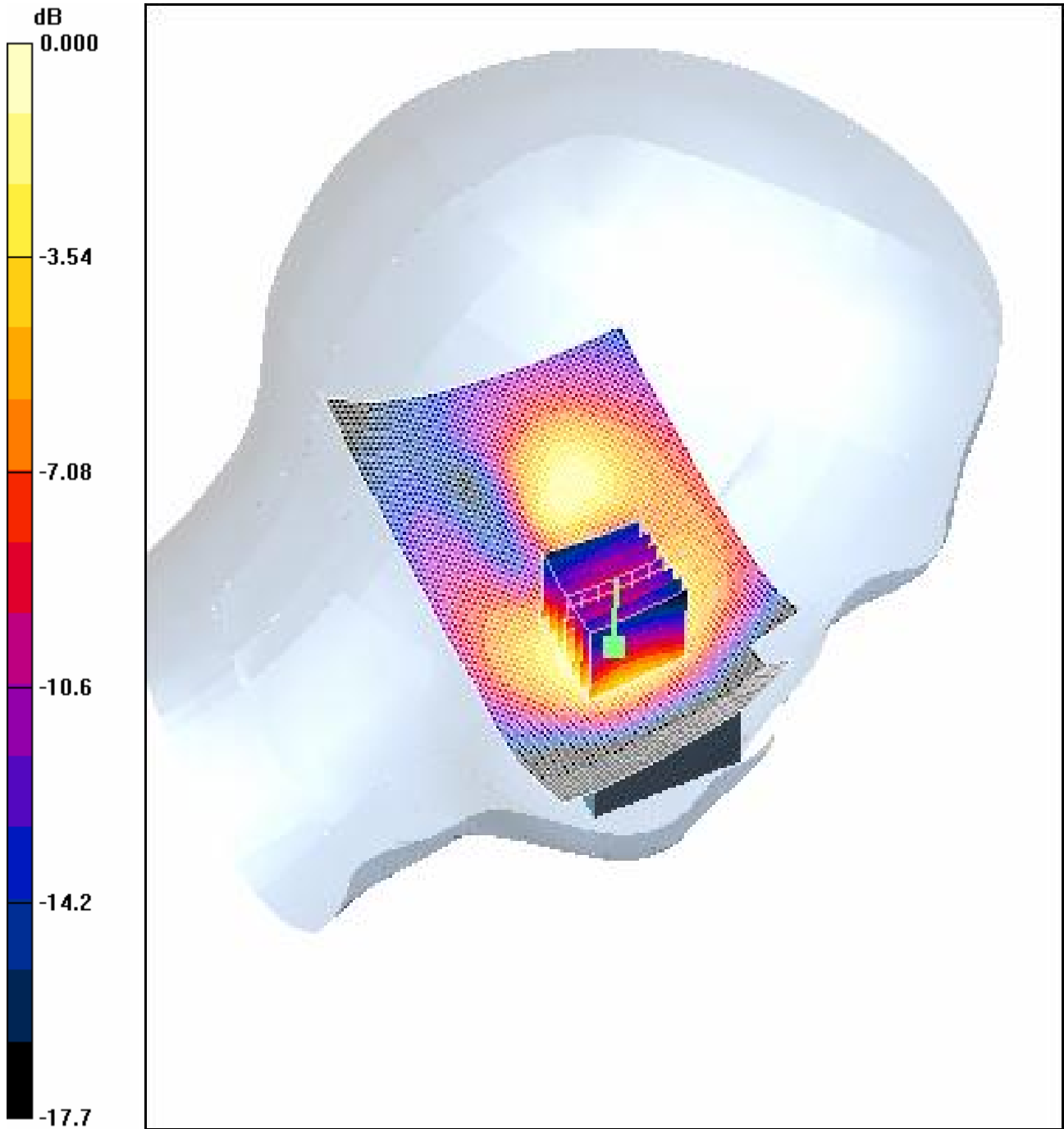

0 dB = 0.215mW/g

4.13LeftHandSide-Tilt-PCS1900-Middle

Date/Time: 2007-8-27 20:27:56

Test Laboratory: SGS-GSM

PCS1900-LeftHandSide-Tilt-Middle

DUT: GSM10528201; Type: Body; Serial: 1#

Communication System: PCS1900-GSM Mode; Frequency: 1880 MHz; Duty Cycle: 1:8.3

Medium: HSL1900_Head Medium parameters used: $f = 1880$ MHz; $\sigma = 1.42$ mho/m; $\epsilon_r = 39.8$; $\rho = 1000$ kg/m³

Phantom section: Left Section

DASY4 Configuration:

- Probe: ES3DV3 - SN3088; ConvF(5.07, 5.07, 5.07); Calibrated: 2006-12-12
- Sensor-Surface: 4mm (Mechanical Surface Detection)
- Electronics: DAE3 Sn569; Calibrated: 2006-12-8
- Phantom: SAM 12; Type: SAM V4.0; Serial: TP-1283
- Measurement SW: DASY4, V4.7 Build 44; Postprocessing SW: SEMCAD, V1.8 Build 171

Tilt position - Middle/Area Scan (61x101x1): Measurement grid: dx=15mm, dy=15mm

Maximum value of SAR (interpolated) = 0.160 mW/g

Tilt position - Middle/Zoom Scan (7x7x7)/Cube 0: Measurement grid: dx=5mm, dy=5mm, dz=5mm

Reference Value = 8.19 V/m; Power Drift = 0.010 dB

Peak SAR (extrapolated) = 0.255 W/kg

SAR(1 g) = 0.140 mW/g; SAR(10 g) = 0.069 mW/g

Maximum value of SAR (measured) = 0.160 mW/g

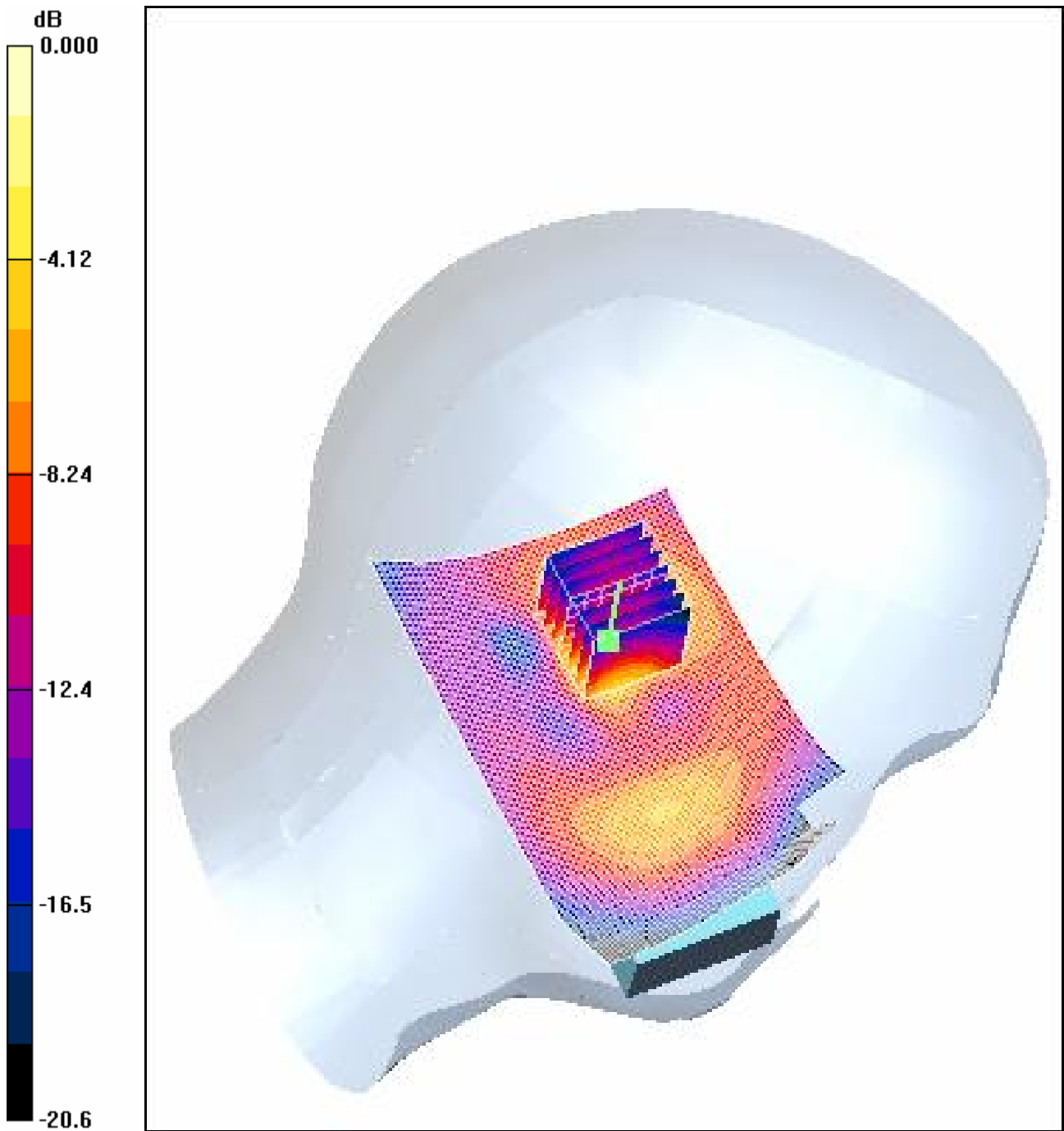

0 dB = 0.160mW/g

4.14LeftHandSide-Cheek-PCS1900-Low

Date/Time: 2007-8-27 19:28:15

Test Laboratory: SGS-GSM

PCS1900-LeftHandSide-Cheek-Low

DUT: GSM10528201; Type: Body; Serial: 1#

Communication System: PCS1900-GSM Mode; Frequency: 1850.2 MHz; Duty Cycle: 1:8.3

Medium: HSL1900_Head Medium parameters used: $f = 1850.2$ MHz; $\sigma = 1.39$ mho/m; $\epsilon_r = 39.9$; $\rho = 1000$ kg/m³

Phantom section: Left Section

DASY4 Configuration:

- Probe: ES3DV3 - SN3088; ConvF(5.07, 5.07, 5.07); Calibrated: 2006-12-12
- Sensor-Surface: 4mm (Mechanical Surface Detection)
- Electronics: DAE3 Sn569; Calibrated: 2006-12-8
- Phantom: SAM 12; Type: SAM V4.0; Serial: TP-1283
- Measurement SW: DASY4, V4.7 Build 44; Postprocessing SW: SEMCAD, V1.8 Build 171

Cheek position - Low/Area Scan (61x101x1): Measurement grid: dx=15mm, dy=15mm

Maximum value of SAR (interpolated) = 0.340 mW/g

Cheek position - Low/Zoom Scan (7x7x7) (7x7x7)/Cube 0: Measurement grid: dx=5mm, dy=5mm, dz=5mm

Reference Value = 10.6 V/m; Power Drift = 0.013 dB

Peak SAR (extrapolated) = 0.427 W/kg

SAR(1 g) = 0.307 mW/g; SAR(10 g) = 0.183 mW/g

Maximum value of SAR (measured) = 0.338 mW/g

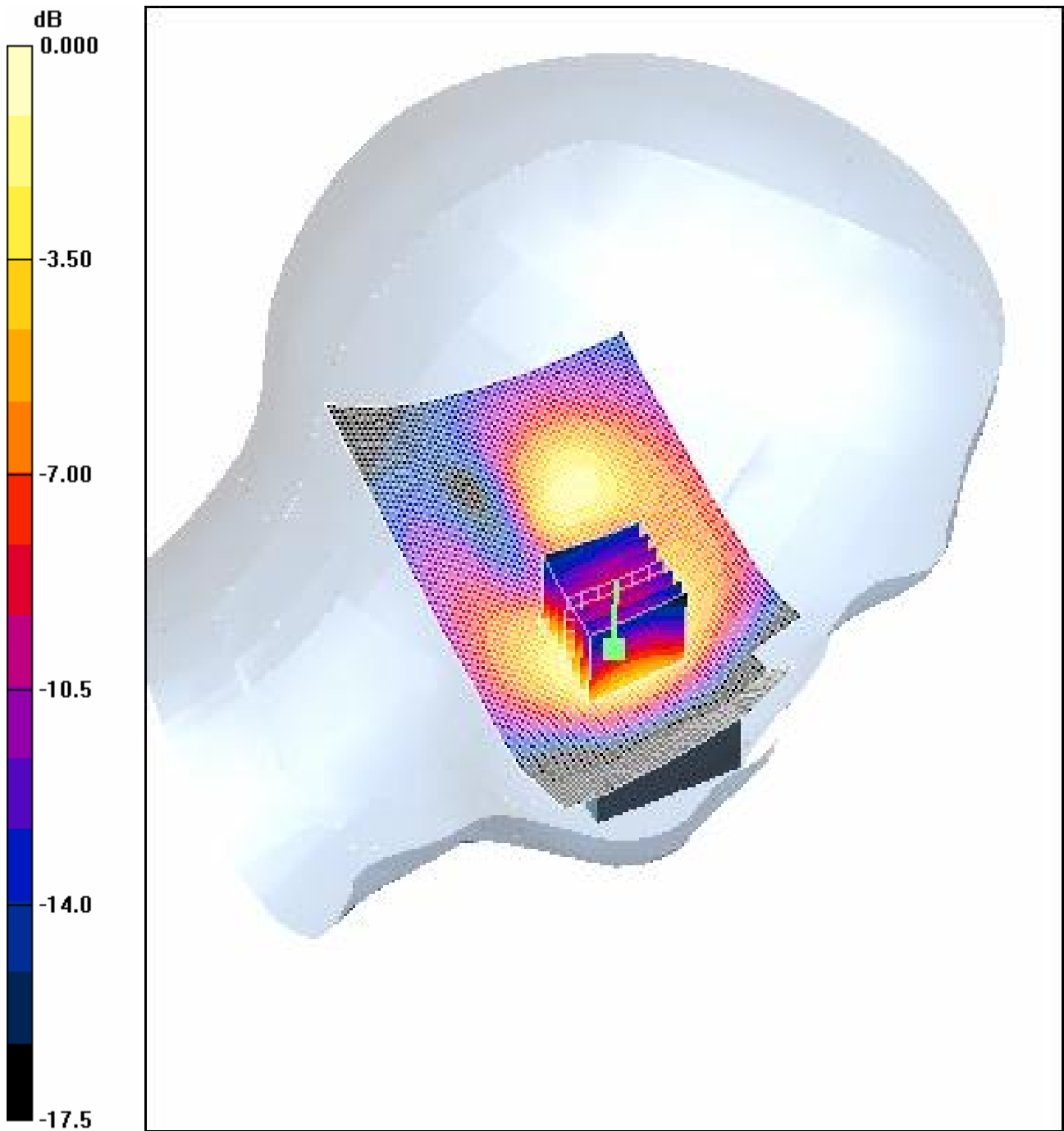

0 dB = 0.338mW/g

4.15LeftHandSide-Cheek-PCS1900-High

Date/Time: 2007-8-27 20:02:25

Test Laboratory: SGS-GSM

PCS1900-LeftHandSide-Cheek-High

DUT: GSM10528201; Type: Body; Serial: 1#

Communication System: PCS1900-GSM Mode; Frequency: 1909.8 MHz; Duty Cycle: 1:8.3

Medium: HSL1900_Head Medium parameters used: $f = 1909.8$ MHz; $\sigma = 1.45$ mho/m; $\epsilon_r = 39.8$; $\rho = 1000$ kg/m³

Phantom section: Left Section

DASY4 Configuration:

- Probe: ES3DV3 - SN3088; ConvF(5.07, 5.07, 5.07); Calibrated: 2006-12-12
- Sensor-Surface: 4mm (Mechanical Surface Detection)
- Electronics: DAE3 Sn569; Calibrated: 2006-12-8
- Phantom: SAM 12; Type: SAM V4.0; Serial: TP-1283
- Measurement SW: DASY4, V4.7 Build 44; Postprocessing SW: SEMCAD, V1.8 Build 171

Cheek position - High/Area Scan (61x101x1): Measurement grid: dx=15mm, dy=15mm

Maximum value of SAR (interpolated) = 0.108 mW/g

Cheek position - High/Zoom Scan (7x7x7) (7x7x7)/Cube 0: Measurement grid: dx=5mm, dy=5mm, dz=5mm

Reference Value = 6.64 V/m; Power Drift = -0.027 dB

Peak SAR (extrapolated) = 0.139 W/kg

SAR(1 g) = 0.098 mW/g; SAR(10 g) = 0.058 mW/g

Maximum value of SAR (measured) = 0.107 mW/g

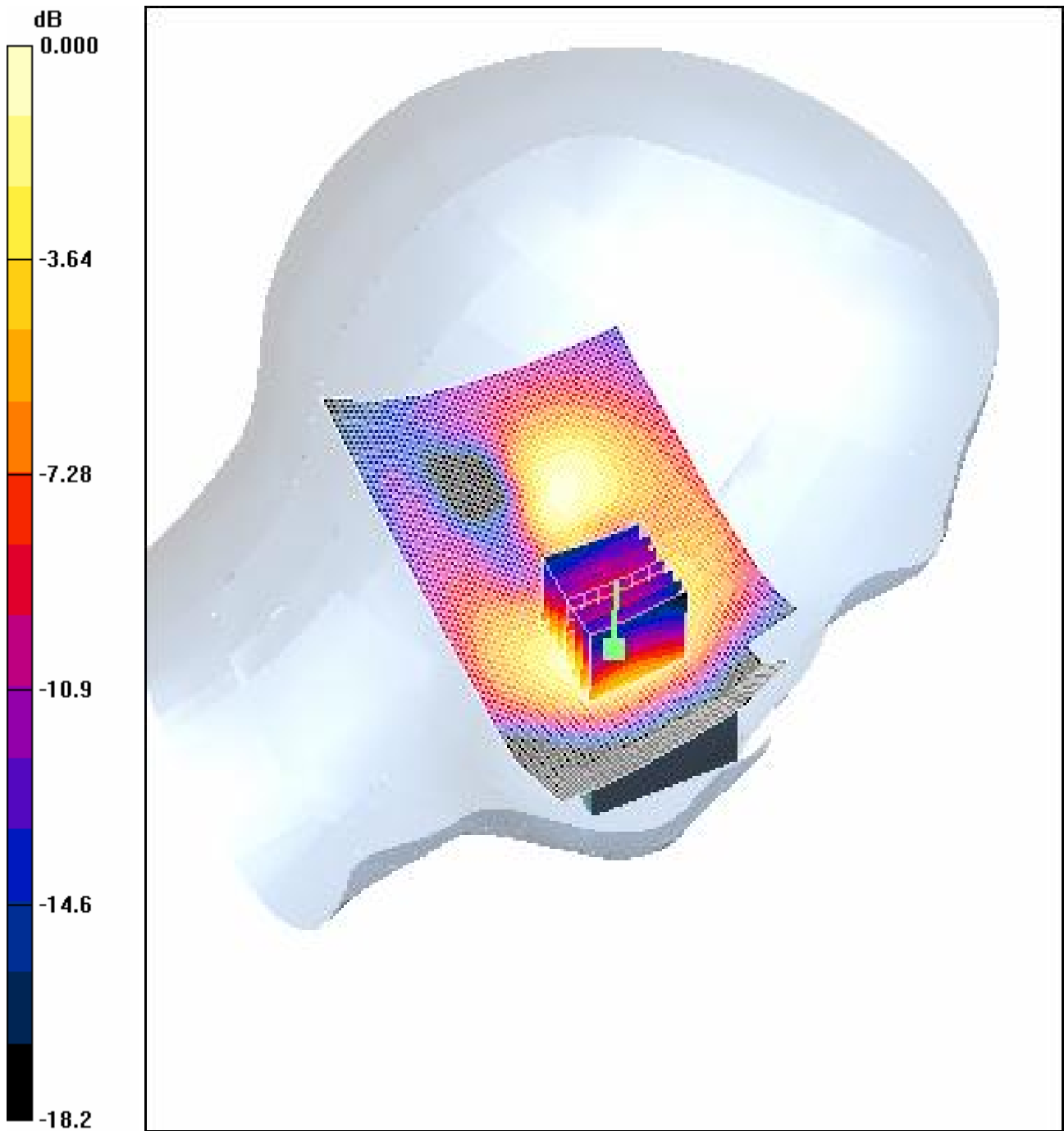

0 dB = 0.107mW/g

4.16RightHandSide-Cheek-PCS1900-Middle

Date/Time: 2007-8-27 16:37:59

Test Laboratory: SGS-GSM

PCS1900-RightHandSide-Cheek-Middle

DUT: GSM10528201; Type: Body; Serial: 1#

Communication System: PCS1900-GSM Mode; Frequency: 1880 MHz; Duty Cycle: 1:8.3

Medium: HSL1900_Head Medium parameters used: $f = 1880$ MHz; $\sigma = 1.42$ mho/m; $\epsilon_r = 39.8$; $\rho = 1000$ kg/m³

Phantom section: Right Section

DASY4 Configuration:

- Probe: ES3DV3 - SN3088; ConvF(5.07, 5.07, 5.07); Calibrated: 2006-12-12
- Sensor-Surface: 4mm (Mechanical Surface Detection)
- Electronics: DAE3 Sn569; Calibrated: 2006-12-8
- Phantom: SAM 12; Type: SAM V4.0; Serial: TP-1283
- Measurement SW: DASY4, V4.7 Build 44; Postprocessing SW: SEMCAD, V1.8 Build 171

Cheek position - Middle/Area Scan (61x91x1): Measurement grid: dx=15mm, dy=15mm
Maximum value of SAR (interpolated) = 0.204 mW/g

Cheek position - Middle/Zoom Scan (7x7x7)/Cube 0: Measurement grid: dx=5mm, dy=5mm,
dz=5mm

Reference Value = 8.99 V/m; Power Drift = 0.037 dB

Peak SAR (extrapolated) = 0.261 W/kg

SAR(1 g) = 0.181 mW/g; SAR(10 g) = 0.106 mW/g

Maximum value of SAR (measured) = 0.195 mW/g

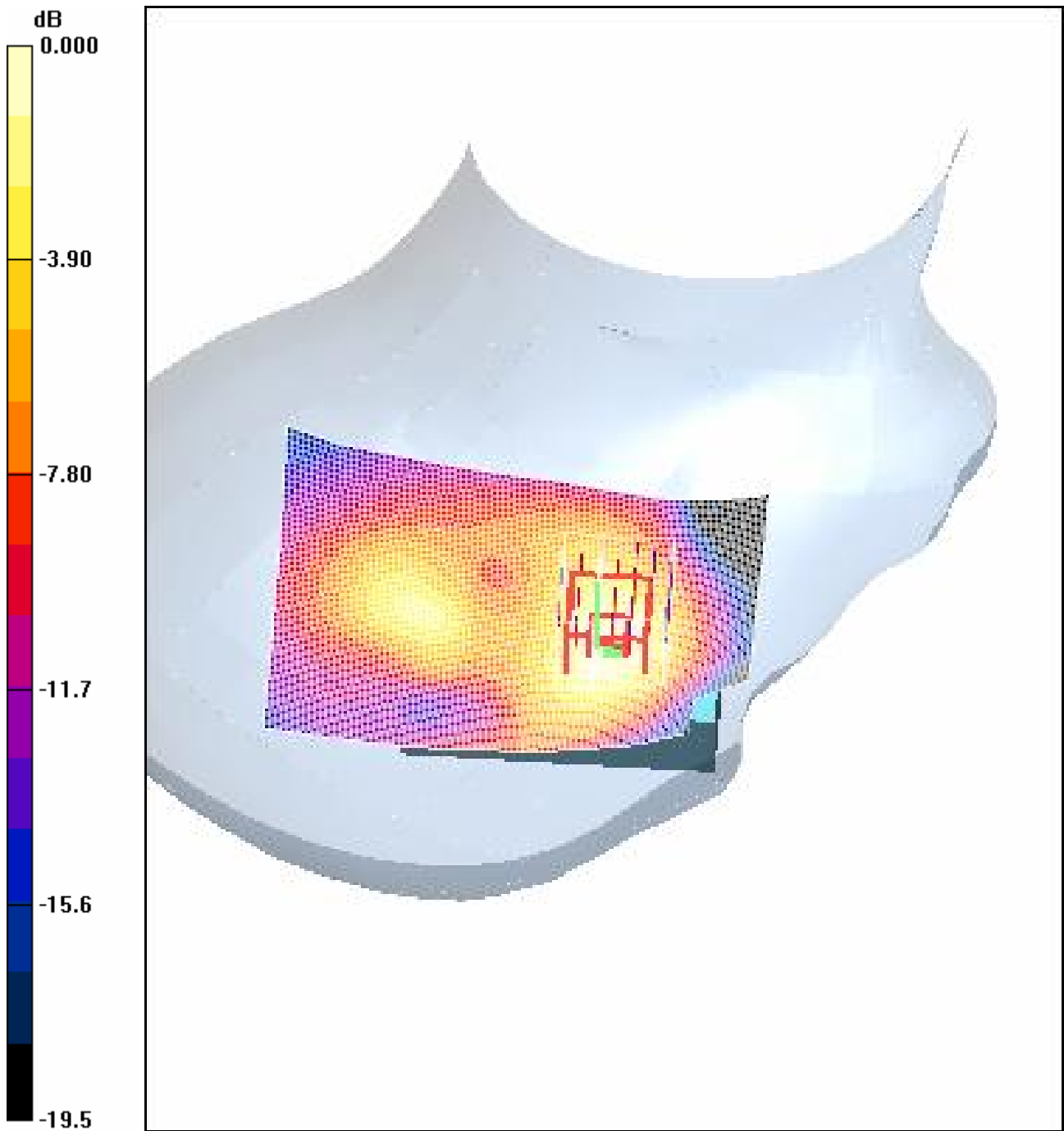

0 dB = 0.195mW/g

4.17RightHandSide-Tilt-PCS1900-Middle

Date/Time: 2007-8-27 17:02:01

Test Laboratory: SGS-GSM

PCS1900-RightHandSide-Tilt-Middle

DUT: GSM10528201; Type: Body; Serial: 1#

Communication System: PCS1900-GSM Mode; Frequency: 1880 MHz; Duty Cycle: 1:8.3

Medium: HSL1900_Head Medium parameters used: $f = 1880$ MHz; $\sigma = 1.42$ mho/m; $\epsilon_r = 39.8$; $\rho = 1000$ kg/m³

Phantom section: Right Section

DASY4 Configuration:

- Probe: ES3DV3 - SN3088; ConvF(5.07, 5.07, 5.07); Calibrated: 2006-12-12
- Sensor-Surface: 4mm (Mechanical Surface Detection)
- Electronics: DAE3 Sn569; Calibrated: 2006-12-8
- Phantom: SAM 12; Type: SAM V4.0; Serial: TP-1283
- Measurement SW: DASY4, V4.7 Build 44; Postprocessing SW: SEMCAD, V1.8 Build 171

Tilt position - Middle/Area Scan (61x101x1): Measurement grid: dx=15mm, dy=15mm

Maximum value of SAR (interpolated) = 0.131 mW/g

Tilt position - Middle/Zoom Scan (7x7x7)/Cube 0: Measurement grid: dx=5mm, dy=5mm, dz=5mm

Reference Value = 8.31 V/m; Power Drift = -0.023 dB

Peak SAR (extrapolated) = 0.207 W/kg

SAR(1 g) = 0.116 mW/g; SAR(10 g) = 0.060 mW/g

Maximum value of SAR (measured) = 0.131 mW/g

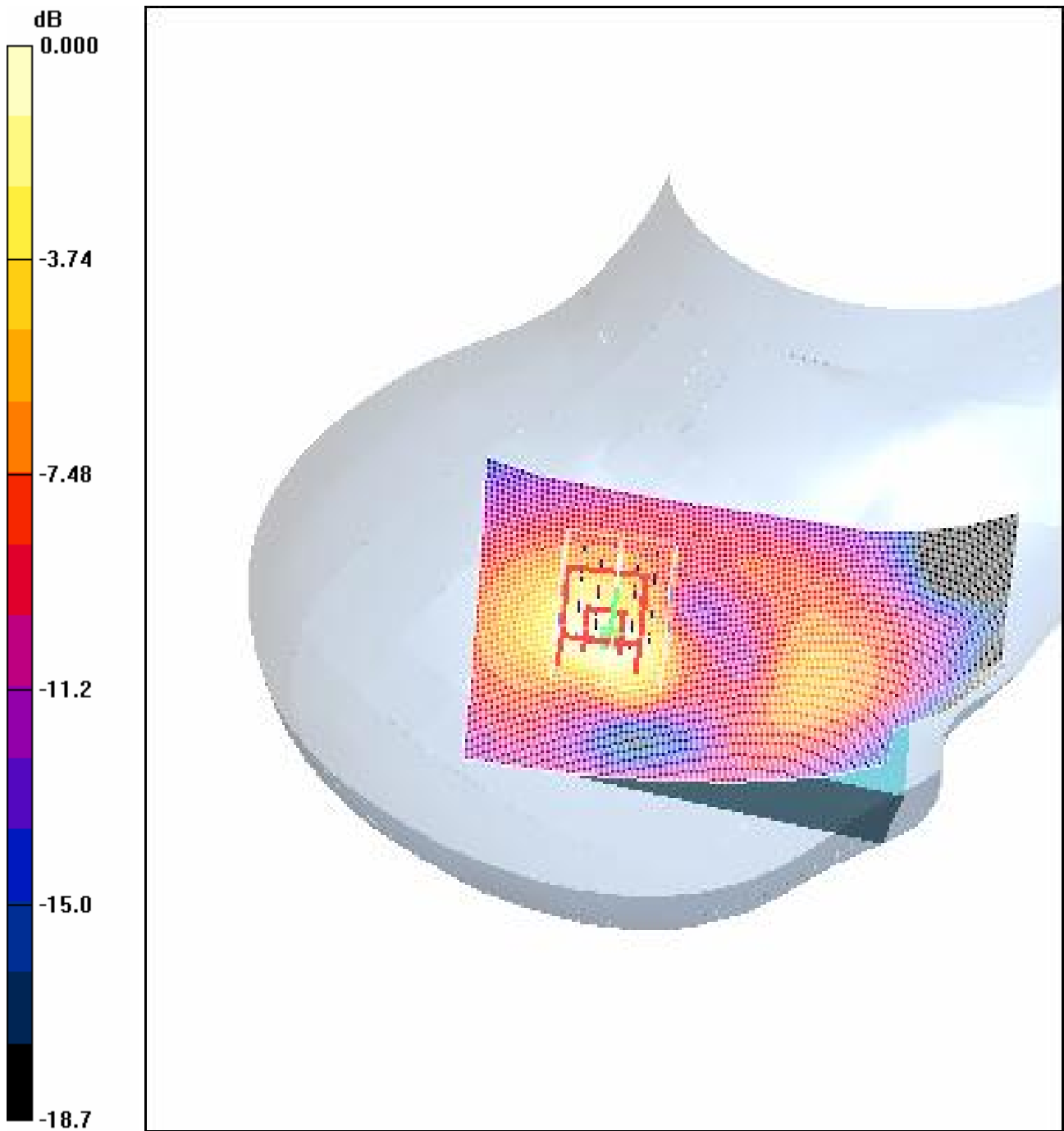

0 dB = 0.131mW/g

4.18RightHandSide-Cheek-PCS1900-Low

Date/Time: 2007-8-27 17:27:48

Test Laboratory: SGS-GSM

PCS1900-RightHandSide-Cheek-Low

DUT: GSM10528201; Type: Body; Serial: 1#

Communication System: PCS1900-GSM Mode; Frequency: 1880 MHz; Duty Cycle: 1:8.3

Medium: HSL1900_Head Medium parameters used: $f = 1880$ MHz; $\sigma = 1.42$ mho/m; $\epsilon_r = 39.8$; $\rho = 1000$ kg/m³

Phantom section: Right Section

DASY4 Configuration:

- Probe: ES3DV3 - SN3088; ConvF(5.07, 5.07, 5.07); Calibrated: 2006-12-12
- Sensor-Surface: 4mm (Mechanical Surface Detection)
- Electronics: DAE3 Sn569; Calibrated: 2006-12-8
- Phantom: SAM 12; Type: SAM V4.0; Serial: TP-1283
- Measurement SW: DASY4, V4.7 Build 44; Postprocessing SW: SEMCAD, V1.8 Build 171

Cheek position - Low/Area Scan (61x101x1): Measurement grid: dx=15mm, dy=15mm

Maximum value of SAR (interpolated) = 0.334 mW/g

Cheek position - Low/Zoom Scan (7x7x7) (7x7x7)/Cube 0: Measurement grid: dx=5mm, dy=5mm, dz=5mm

Reference Value = 10.8 V/m; Power Drift = -0.040 dB

Peak SAR (extrapolated) = 0.428 W/kg

SAR(1 g) = 0.297 mW/g; SAR(10 g) = 0.175 mW/g

Maximum value of SAR (measured) = 0.321 mW/g

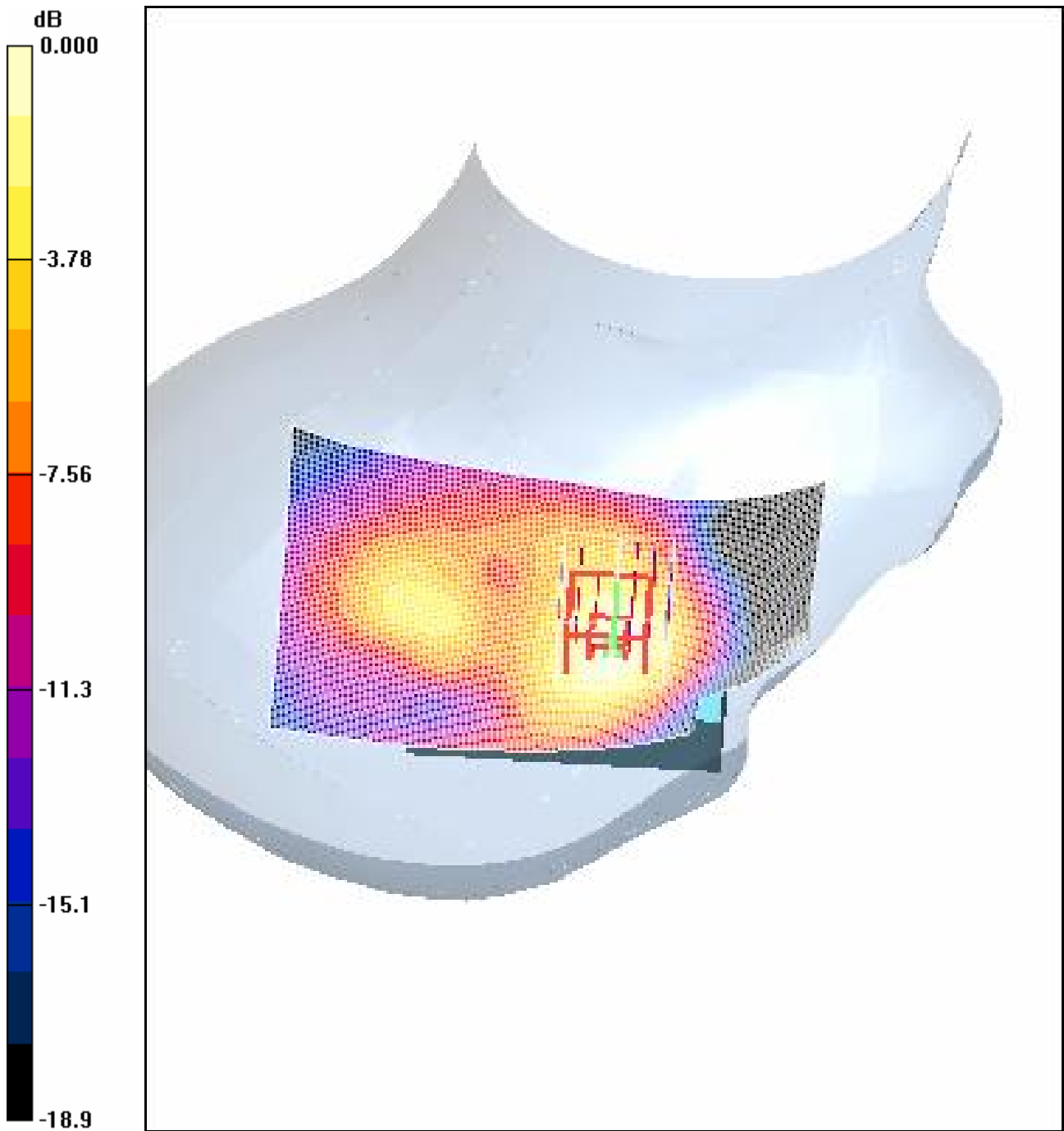

0 dB = 0.321mW/g

4.19RightHandSide-Cheek-PCS1900-High

Date/Time: 2007-8-27 18:30:59

Test Laboratory: SGS-GSM

PCS1900-RightHandSide-Cheek-High

DUT: GSM10528201; Type: Body; Serial: 1#

Communication System: PCS1900-GSM Mode; Frequency: 1909.8 MHz; Duty Cycle: 1:8.3

Medium: HSL1900_Head Medium parameters used: $f = 1909.8$ MHz; $\sigma = 1.45$ mho/m; $\epsilon_r = 39.8$; $\rho = 1000$ kg/m³

Phantom section: Right Section

DASY4 Configuration:

- Probe: ES3DV3 - SN3088; ConvF(5.07, 5.07, 5.07); Calibrated: 2006-12-12
- Sensor-Surface: 4mm (Mechanical Surface Detection)
- Electronics: DAE3 Sn569; Calibrated: 2006-12-8
- Phantom: SAM 12; Type: SAM V4.0; Serial: TP-1283
- Measurement SW: DASY4, V4.7 Build 44; Postprocessing SW: SEMCAD, V1.8 Build 171

Cheek position - High/Area Scan (61x101x1): Measurement grid: dx=15mm, dy=15mm

Maximum value of SAR (interpolated) = 0.110 mW/g

Cheek position - High/Zoom Scan (7x7x7) (7x7x7)/Cube 0: Measurement grid: dx=5mm, dy=5mm, dz=5mm

Reference Value = 6.70 V/m; Power Drift = -0.016 dB

Peak SAR (extrapolated) = 0.143 W/kg

SAR(1 g) = 0.098 mW/g; SAR(10 g) = 0.057 mW/g

Maximum value of SAR (measured) = 0.107 mW/g

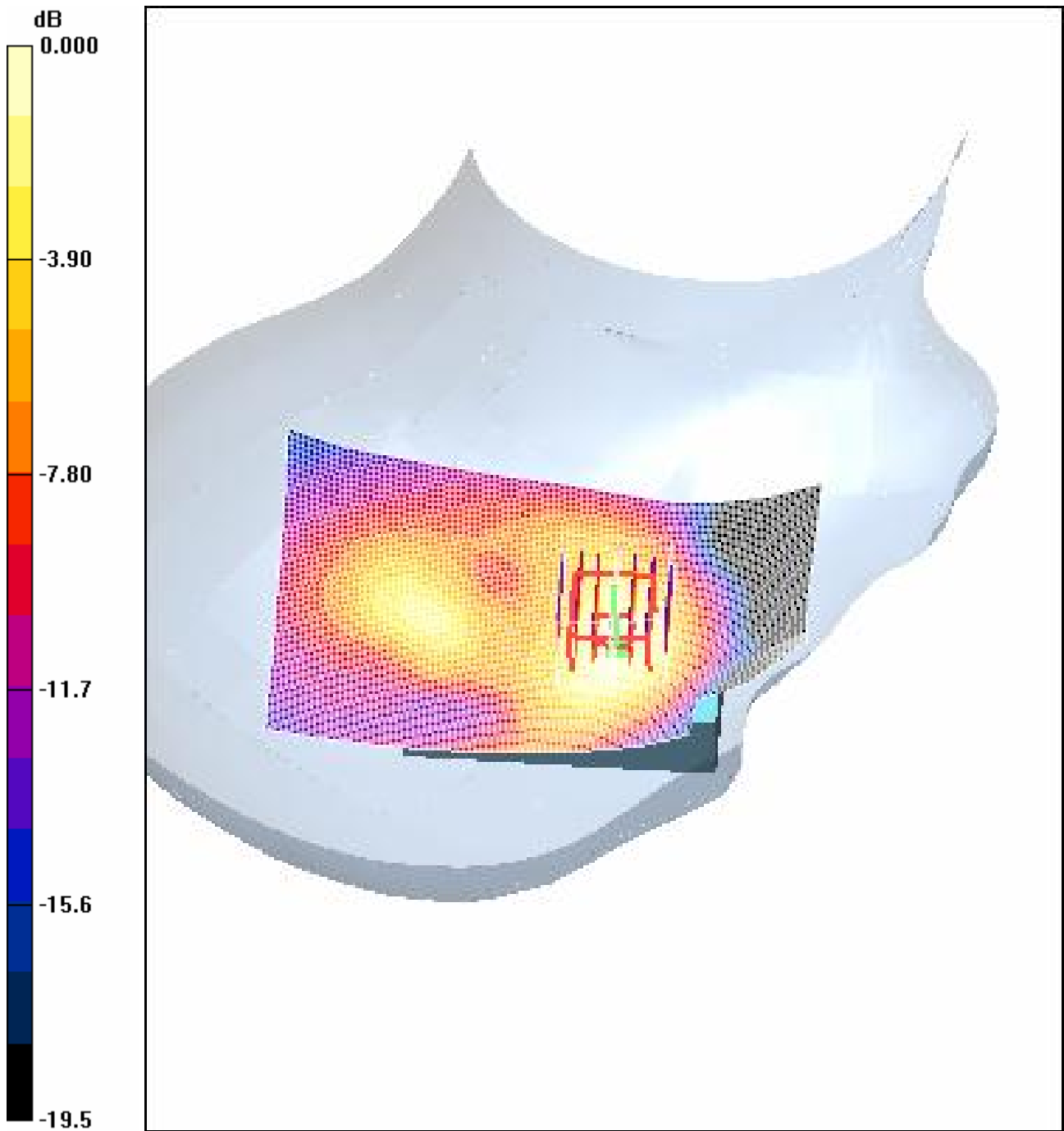

0 dB = 0.107mW/g

4.20Body-Worn-PCS1900-Low

Date/Time: 2007-8-23 12:50:11

Test Laboratory: SGS-GSM

PCS1900-Body-Worn-Low-2.0cm

DUT: GSM10528201; Type: Body; Serial: 1#

Communication System: PCS1900-GSM Mode; Frequency: 1850.2 MHz; Duty Cycle: 1:8.3

Medium: HSL1900_Body Medium parameters used: $f = 1850.2$ MHz; $\sigma = 1.51$ mho/m; $\epsilon_r = 51.9$; $\rho = 1000$ kg/m³

Phantom section: Flat Section

DASY4 Configuration:

- Probe: ES3DV3 - SN3088; ConvF(4.68, 4.68, 4.68); Calibrated: 2006-12-12
- Sensor-Surface: 4mm (Mechanical Surface Detection)
- Electronics: DAE3 Sn569; Calibrated: 2006-12-8
- Phantom: SAM 12; Type: SAM V4.0; Serial: TP-1283
- Measurement SW: DASY4, V4.7 Build 44; Postprocessing SW: SEMCAD, V1.8 Build 171

Body Worn - Low/Area Scan (51x91x1): Measurement grid: dx=15mm, dy=15mm

Maximum value of SAR (interpolated) = 0.448 mW/g

Body Worn - Low/Zoom Scan (7x7x7) (7x7x7)/Cube 0: Measurement grid: dx=5mm, dy=5mm, dz=5mm

Reference Value = 7.89 V/m; Power Drift = 0.044 dB

Peak SAR (extrapolated) = 0.643 W/kg

SAR(1 g) = 0.408 mW/g; SAR(10 g) = 0.254 mW/g

Maximum value of SAR (measured) = 0.441 mW/g

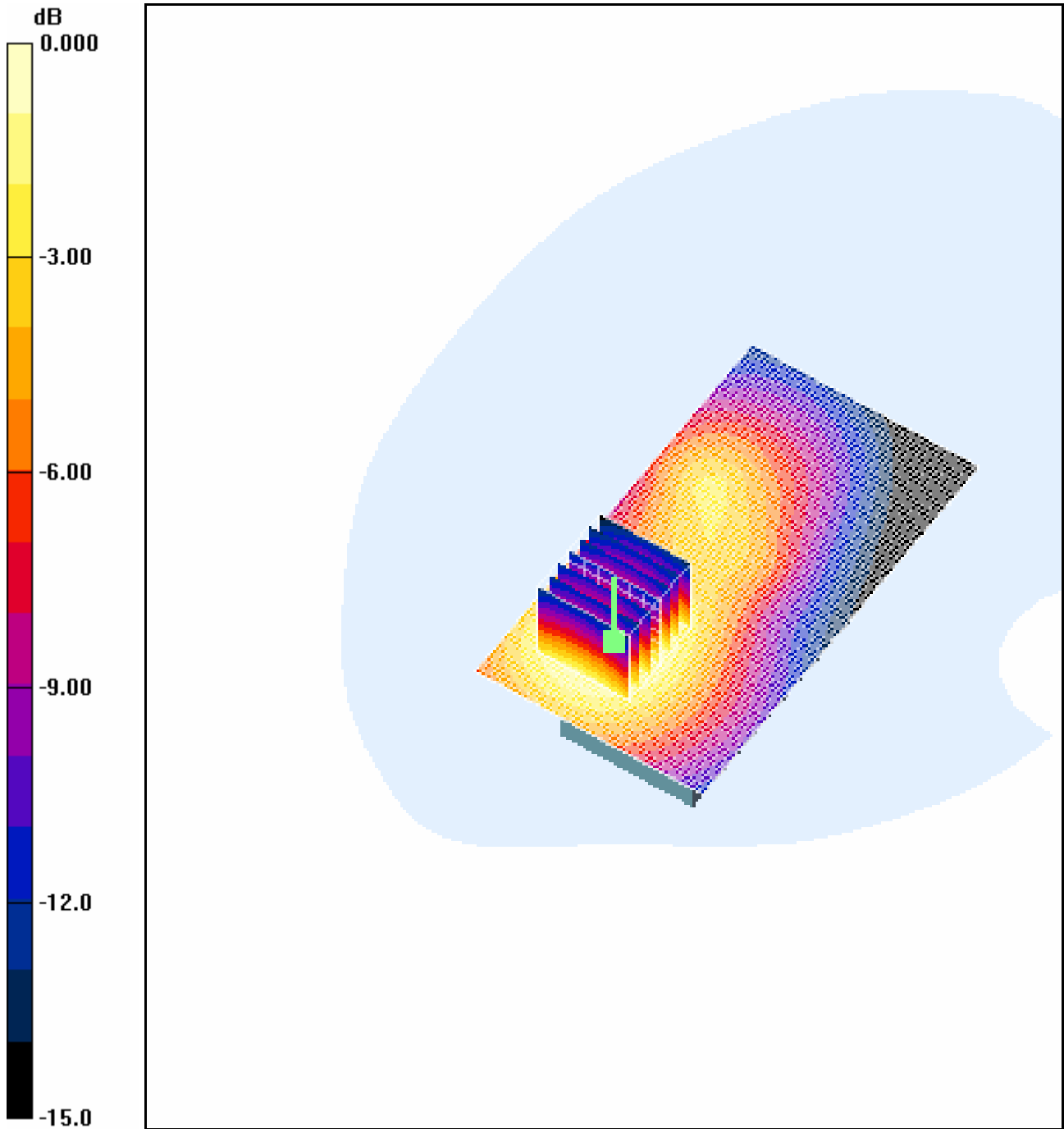

0 dB = 0.441mW/g

4.21Body-Worn-PCS1900-Middle

Date/Time: 2007-8-23 11:42:18

Test Laboratory: SGS-GSM

PCS1900-Body-Worn-Middle-2.0cm

DUT: GSM10528201; Type: Body; Serial: 1#

Communication System: PCS1900-GSM Mode; Frequency: 1880 MHz; Duty Cycle: 1:8.3

Medium: HSL1900_Body Medium parameters used: $f = 1880$ MHz; $\sigma = 1.54$ mho/m; $\epsilon_r = 51.7$; $\rho = 1000$ kg/m³

Phantom section: Flat Section

DASY4 Configuration:

- Probe: ES3DV3 - SN3088; ConvF(4.68, 4.68, 4.68); Calibrated: 2006-12-12
- Sensor-Surface: 4mm (Mechanical Surface Detection)
- Electronics: DAE3 Sn569; Calibrated: 2006-12-8
- Phantom: SAM 12; Type: SAM V4.0; Serial: TP-1283
- Measurement SW: DASY4, V4.7 Build 44; Postprocessing SW: SEMCAD, V1.8 Build 171

Body Worn - Middle/Area Scan (51x91x1): Measurement grid: dx=15mm, dy=15mm

Maximum value of SAR (interpolated) = 0.356 mW/g

Body Worn - Middle/Zoom Scan (7x7x7)/Cube 0: Measurement grid: dx=5mm, dy=5mm, dz=5mm

Reference Value = 7.11 V/m; Power Drift = 0.103 dB

Peak SAR (extrapolated) = 0.521 W/kg

SAR(1 g) = 0.327 mW/g; SAR(10 g) = 0.203 mW/g

Maximum value of SAR (measured) = 0.354 mW/g

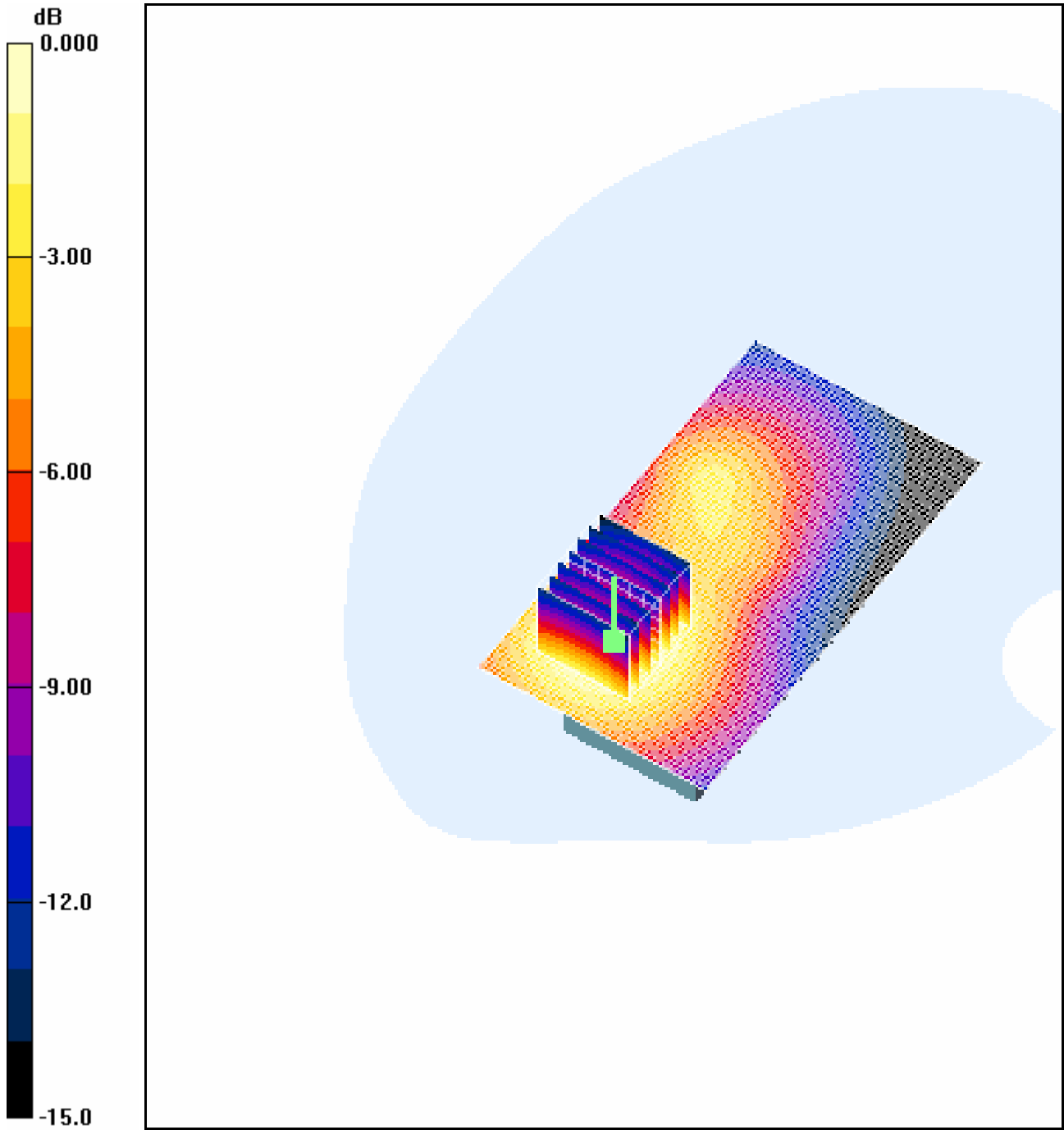

0 dB = 0.354mW/g

4.22Body-Worn-PCS1900-High

Date/Time: 2007-8-23 11:09:20

Test Laboratory: SGS-GSM

PCS1900-Body-Worn-High-2.0cm

DUT: GSM10528201; Type: Body; Serial: 1#

Communication System: PCS1900-GSM Mode; Frequency: 1909.8 MHz; Duty Cycle: 1:8.3

Medium: HSL1900_Body Medium parameters used: $f = 1909.8$ MHz; $\sigma = 1.57$ mho/m; $\epsilon_r = 51.6$; $\rho = 1000$ kg/m³

Phantom section: Flat Section

DASY4 Configuration:

- Probe: ES3DV3 - SN3088; ConvF(4.68, 4.68, 4.68); Calibrated: 2006-12-12
- Sensor-Surface: 4mm (Mechanical Surface Detection)
- Electronics: DAE3 Sn569; Calibrated: 2006-12-8
- Phantom: SAM 12; Type: SAM V4.0; Serial: TP-1283
- Measurement SW: DASY4, V4.7 Build 44; Postprocessing SW: SEMCAD, V1.8 Build 171

Body Worn - High/Area Scan (51x91x1): Measurement grid: dx=15mm, dy=15mm

Maximum value of SAR (interpolated) = 0.214 mW/g

Body Worn - High/Zoom Scan (7x7x7) (7x7x7)/Cube 0: Measurement grid: dx=5mm, dy=5mm, dz=5mm

Reference Value = 5.39 V/m; Power Drift = 0.036 dB

Peak SAR (extrapolated) = 0.312 W/kg

SAR(1 g) = 0.195 mW/g; SAR(10 g) = 0.119 mW/g

Maximum value of SAR (measured) = 0.211 mW/g

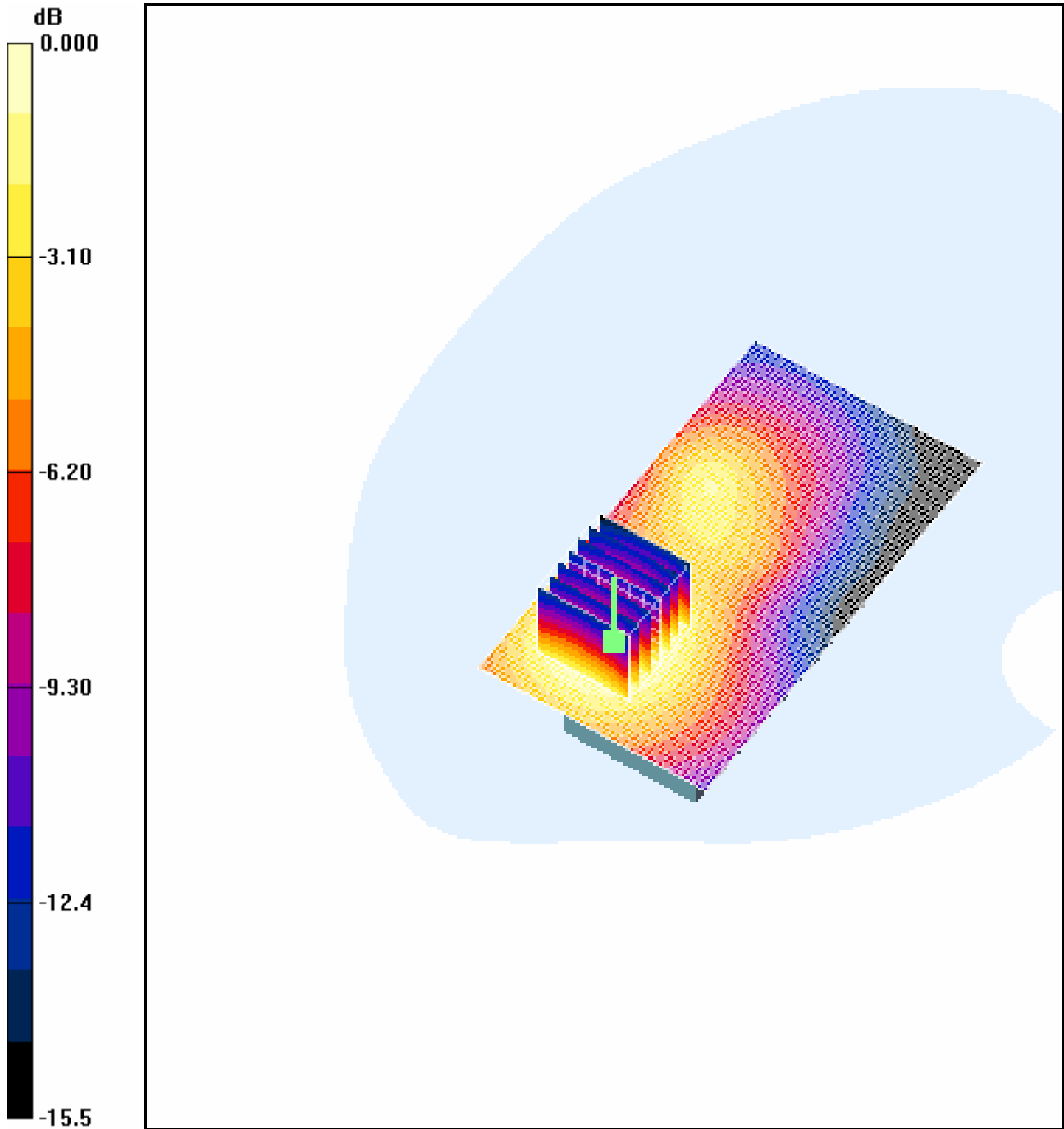

0 dB = 0.211mW/g

Appendix

1. Photographs of Test Setup

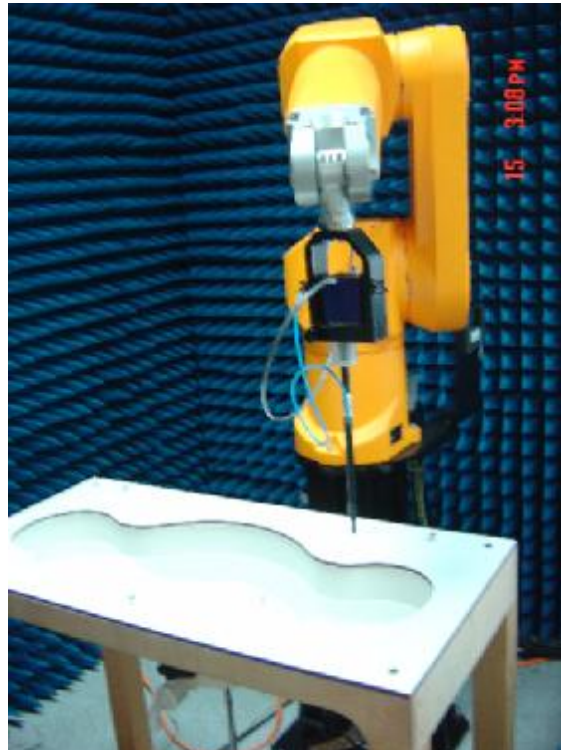

Fig.1 Photograph of the SAR measurement System

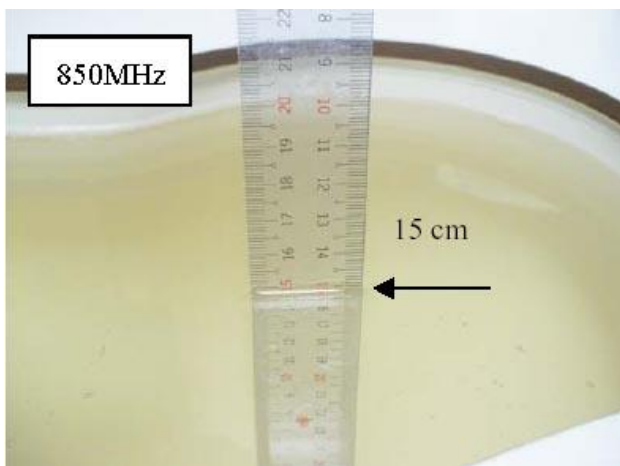

Fig.2 Photograph of the Tissue Simulant Fluid Liquid depth 15cm for Left-Head Side

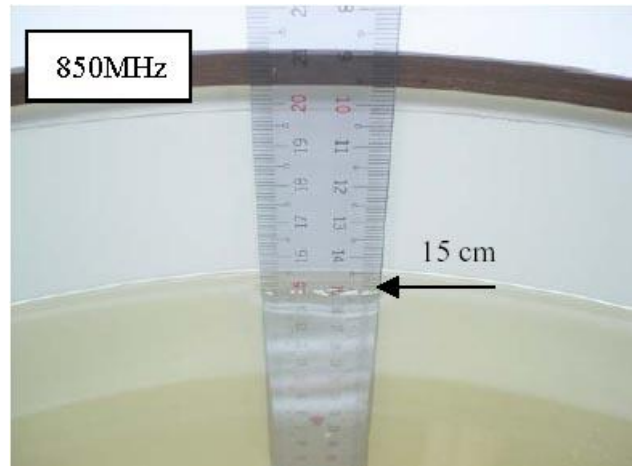

Fig.3 Photograph of the Tissue Simulant Liquid depth 15cm for Body-Worn

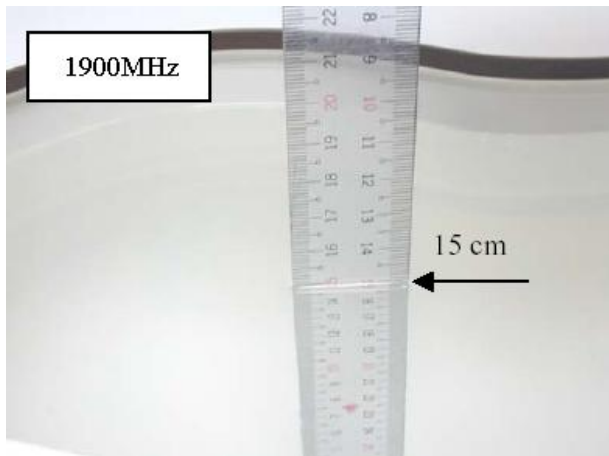

Fig.4 Photograph of the Tissue Simulant Fluid Liquid depth 15cm for Right-Head Side

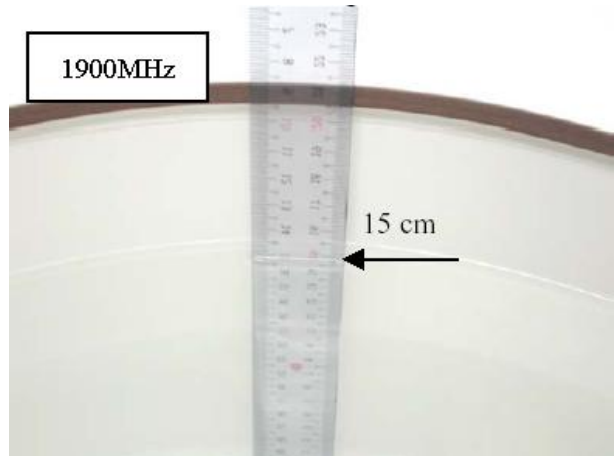

Fig.5 Photograph of the Tissue Simulant Liquid depth 15cm for Body-Worn

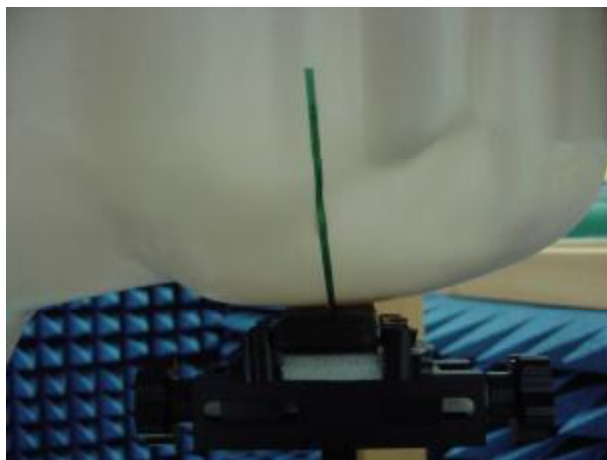

Fig.6 Photograph of the Left Hand Side Cheek status

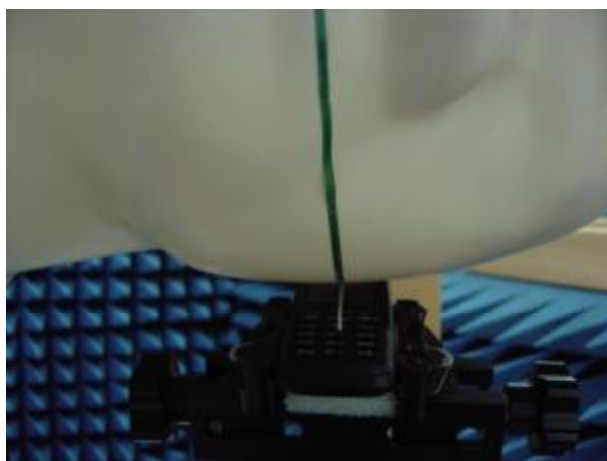
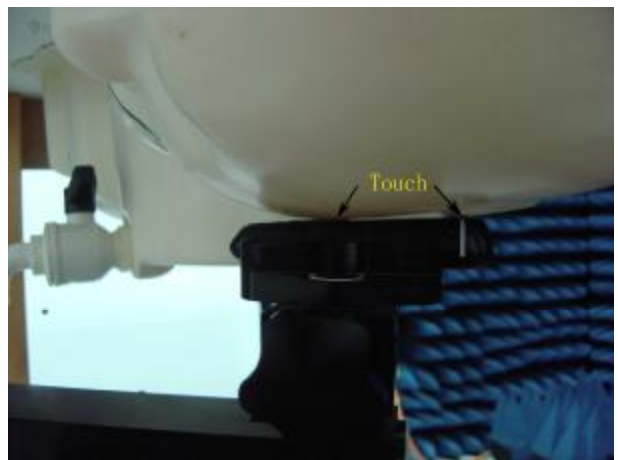

Fig.7 Photograph of the Left Hand Side Tilt status



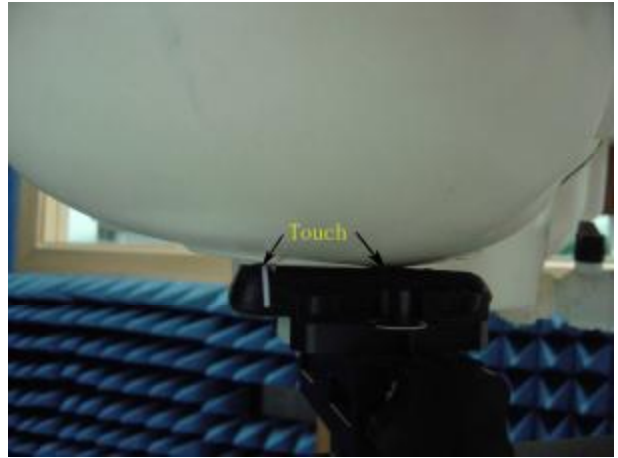
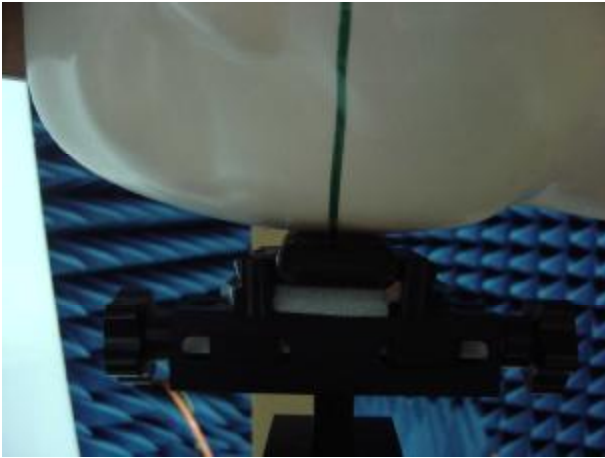

Fig.8 Photograph of the Right Hand Side Cheek status

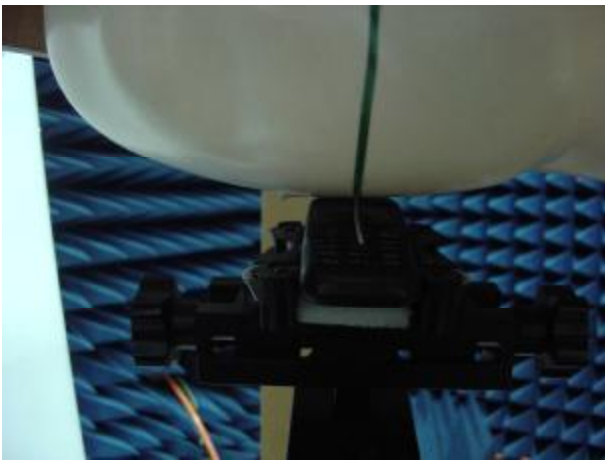

Fig.9 Photograph of the Right Hand Side Tilt status

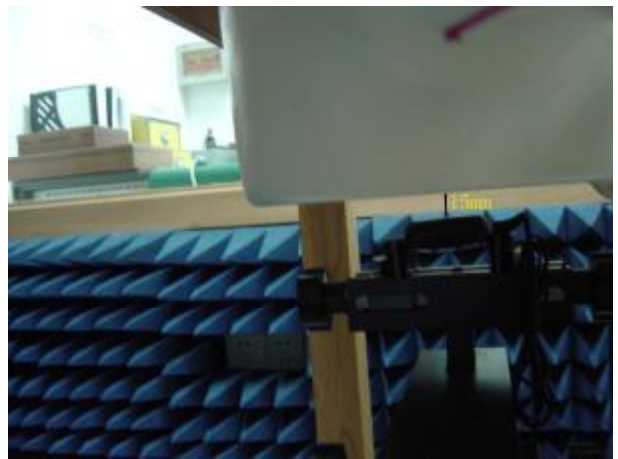

Fig.10 Photograph of the BodyWorn status

2. Photographs of the EUT



Fig.11 Front View



Fig.12 Back View

3. Photographs of the battery



Fig. 13 Front view of battery



Fig. 14 Back view of battery

4. Photograph of the charger



Fig.15 Charger

5. Probe Calibration certificate

Calibration Laboratory of
 Schmid & Partner
 Engineering AG
 Zeughausstrasse 43, 8004 Zurich, Switzerland



S Schweizerischer Kalibrierdienst
 S Service suisse d'étalonnage
 C Servizio svizzero di taratura
 S Swiss Calibration Service

Accredited by the Swiss Federal Office of Metrology and Accreditation
 The Swiss Accreditation Service is one of the signatories to the EA
 Multilateral Agreement for the recognition of calibration certificates

Accreditation No.: SCS 108

Client SGS-CSTC (MTT)

Certificate No: ES3-3088_Dec06

CALIBRATION CERTIFICATE

Object ES3DV3 - SN:3088

Calibration procedure(s) QA CAL-01.v5
 Calibration procedure for dosimetric E-field probes

Calibration date: December 12, 2006

Condition of the calibrated item In Tolerance

This calibration certificate documents the traceability to national standards, which realize the physical units of measurements (SI).
 The measurements and the uncertainties with confidence probability are given on the following pages and are part of the certificate.

All calibrations have been conducted in the closed laboratory facility: environment temperature (22 ± 3)°C and humidity < 70%.

Calibration Equipment used (M&TE critical for calibration)

Primary Standards	ID #	Cal Date (Calibrated by, Certificate No.)	Scheduled Calibration
Power meter E4418B	GB41293874	5-Apr-06 (METAS, No. 251-00557)	Apr-07
Power sensor E4412A	MY41495277	5-Apr-06 (METAS, No. 251-00557)	Apr-07
Power sensor E4412A	MY41498087	5-Apr-06 (METAS, No. 251-00557)	Apr-07
Reference 3 dB Attenuator	SN: S5054 (3c)	10-Aug-06 (METAS, No. 217-00592)	Aug-07
Reference 20 dB Attenuator	SN: S5086 (20b)	4-Apr-06 (METAS, No. 251-00558)	Apr-07
Reference 30 dB Attenuator	SN: S5129 (30b)	10-Aug-06 (METAS, No. 217-00593)	Aug-07
Reference Probe ES3DV2	SN: 3013	2-Jan-06 (SPEAG, No. ES3-3013_Jan06)	Jan-07
DAE4	SN: 654	21-Jun-06 (SPEAG, No. DAE4-654_Jun06)	Jun-07

Secondary Standards	ID #	Check Date (in house)	Scheduled Check
RF generator HP 8648C	US3642U01700	4-Aug-99 (SPEAG, in house check Nov-05)	In house check: Nov-07
Network Analyzer HP 8753E	US37390585	18-Oct-01 (SPEAG, in house check Oct-06)	In house check: Oct-07

Calibrated by:	Name	Function	Signature
	Katja Prokovic	Technical Manager	
Approved by:	Niels Kuster	Quality Manager	

Issued: December 13, 2006

This calibration certificate shall not be reproduced except in full without written approval of the laboratory.

Calibration Laboratory of
Schmid & Partner
Engineering AG
Zeughausstrasse 43, 8004 Zurich, Switzerland



S Schweizerischer Kalibrierdienst
C Service suisse d'étalonnage
S Servizio svizzero di taratura
S Swiss Calibration Service

Accredited by the Swiss Federal Office of Metrology and Accreditation
The Swiss Accreditation Service is one of the signatories to the EA
Multilateral Agreement for the recognition of calibration certificates

Accreditation No.: **SCS 108**

Glossary:

TSL	tissue simulating liquid
NORM _{x,y,z}	sensitivity in free space
ConF	sensitivity in TSL / NORM _{x,y,z}
DCP	diode compression point
Polarization φ	φ rotation around probe axis
Polarization ϑ	ϑ rotation around an axis that is in the plane normal to probe axis (at measurement center), i.e., $\vartheta = 0$ is normal to probe axis

Calibration is Performed According to the Following Standards:

- IEEE Std 1528-2003, "IEEE Recommended Practice for Determining the Peak Spatial-Averaged Specific Absorption Rate (SAR) in the Human Head from Wireless Communications Devices: Measurement Techniques", December 2003
- CENELEC EN 50361, "Basic standard for the measurement of Specific Absorption Rate related to human exposure to electromagnetic fields from mobile phones (300 MHz - 3 GHz), July 2001

Methods Applied and Interpretation of Parameters:

- NORM_{x,y,z}**: Assessed for E-field polarization $\vartheta = 0$ ($f \leq 900$ MHz in TEM-cell; $f > 1800$ MHz: R22 waveguide). NORM_{x,y,z} are only intermediate values, i.e., the uncertainties of NORM_{x,y,z} does not effect the E²-field uncertainty inside TSL (see below *ConvF*).
- NORM(f)_{x,y,z}** = NORM_{x,y,z} * *frequency_response* (see Frequency Response Chart). This linearization is implemented in DASY4 software versions later than 4.2. The uncertainty of the frequency response is included in the stated uncertainty of *ConvF*.
- DCP_{x,y,z}**: DCP are numerical linearization parameters assessed based on the data of power sweep (no uncertainty required). DCP does not depend on frequency nor media.
- ConvF and Boundary Effect Parameters**: Assessed in flat phantom using E-field (or Temperature Transfer Standard for $f \leq 800$ MHz) and inside waveguide using analytical field distributions based on power measurements for $f > 800$ MHz. The same setups are used for assessment of the parameters applied for boundary compensation (alpha, depth) of which typical uncertainty values are given. These parameters are used in DASY4 software to improve probe accuracy close to the boundary. The sensitivity in TSL corresponds to NORM_{x,y,z} * *ConvF* whereby the uncertainty corresponds to that given for *ConvF*. A frequency dependent *ConvF* is used in DASY version 4.4 and higher which allows extending the validity from ± 50 MHz to ± 100 MHz.
- Spherical isotropy (3D deviation from isotropy)**: in a field of low gradients realized using a flat phantom exposed by a patch antenna.
- Sensor Offset**: The sensor offset corresponds to the offset of virtual measurement center from the probe tip (on probe axis). No tolerance required.

ES3DV3 SN:3088

December 12, 2006

Probe ES3DV3

SN:3088

Manufactured:	July 20, 2005
Last calibrated:	September 13, 2005
Recalibrated:	December 12, 2006

Calibrated for DASY Systems

(Note: non-compatible with DASY2 system!)

ES3DV3 SN:3088

December 12, 2006

DASY - Parameters of Probe: ES3DV3 SN:3088

Sensitivity in Free Space ^A			Diode Compression ^B	
NormX	1.31 ± 10.1%	$\mu\text{V}/(\text{V}/\text{m})^2$	DCP X	94 mV
NormY	1.23 ± 10.1%	$\mu\text{V}/(\text{V}/\text{m})^2$	DCP Y	94 mV
NormZ	1.27 ± 10.1%	$\mu\text{V}/(\text{V}/\text{m})^2$	DCP Z	93 mV

Sensitivity in Tissue Simulating Liquid (Conversion Factors)

Please see Page 8.

Boundary Effect

TSL	900 MHz	Typical SAR gradient: 5 % per mm	
	Sensor Center to Phantom Surface Distance	3.0 mm	4.0 mm
	SAR _{be} [%] Without Correction Algorithm	2.4	0.6
	SAR _{be} [%] With Correction Algorithm	1.0	0.0
TSL	1810 MHz	Typical SAR gradient: 10 % per mm	
	Sensor Center to Phantom Surface Distance	3.0 mm	4.0 mm
	SAR _{be} [%] Without Correction Algorithm	7.6	4.5
	SAR _{be} [%] With Correction Algorithm	0.1	0.2

Sensor Offset

Probe Tip to Sensor Center 2.0 mm

The reported uncertainty of measurement is stated as the standard uncertainty of measurement multiplied by the coverage factor k=2, which for a normal distribution corresponds to a coverage probability of approximately 95%.

^A The uncertainties of NormX,Y,Z do not affect the E²-field uncertainty inside TSL (see Page 8).

^B Numerical linearization parameter: uncertainty not required.

ES3DV3 SN:3088

December 12, 2006

Frequency Response of E-Field

(TEM-Cell:ifi110 EXX, Waveguide: R22)

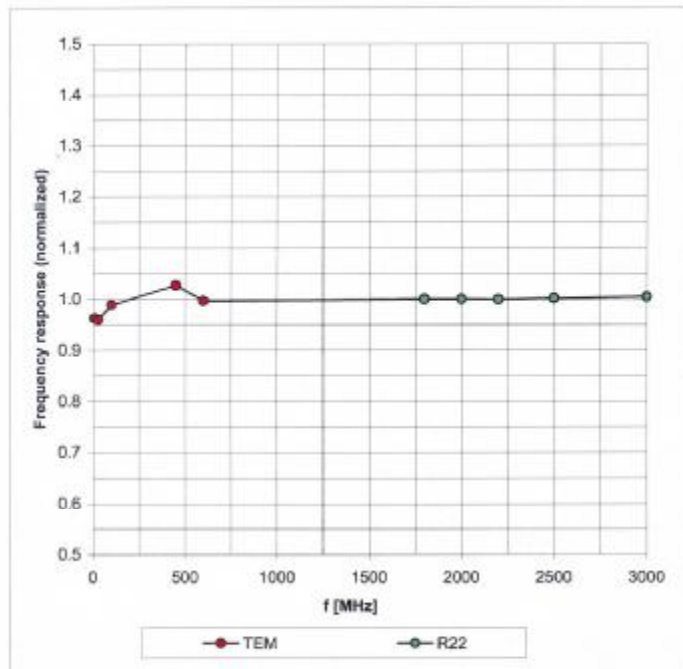

Uncertainty of Frequency Response of E-field: $\pm 6.3\%$ (k=2)

ES3DV3 SN:3088

December 12, 2006

Receiving Pattern (ϕ), $\vartheta = 0^\circ$

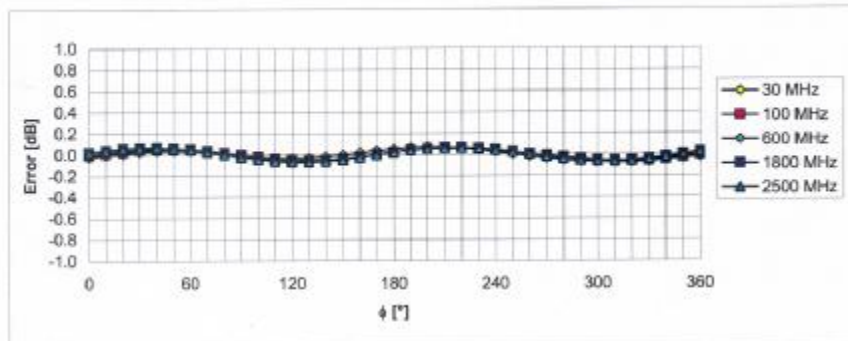
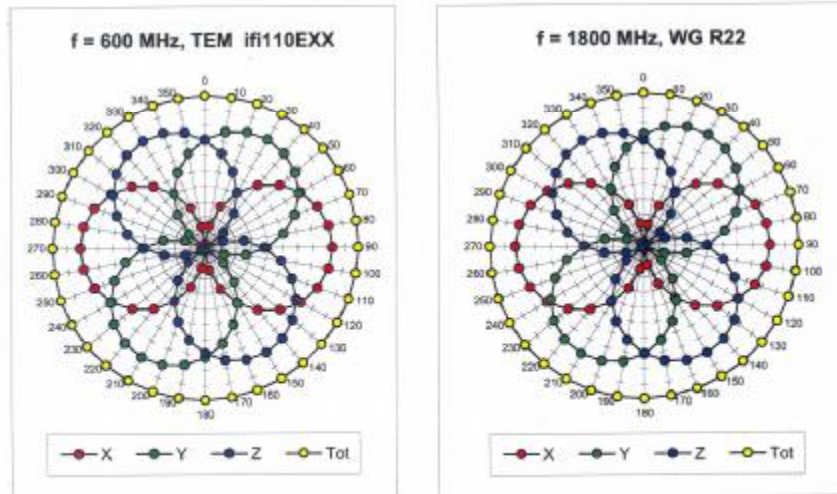

Uncertainty of Axial Isotropy Assessment: $\pm 0.5\%$ ($k=2$)

ES3DV3 SN:3088

December 12, 2006

Dynamic Range f(SAR_{head}) (Waveguide R22, f = 1800 MHz)

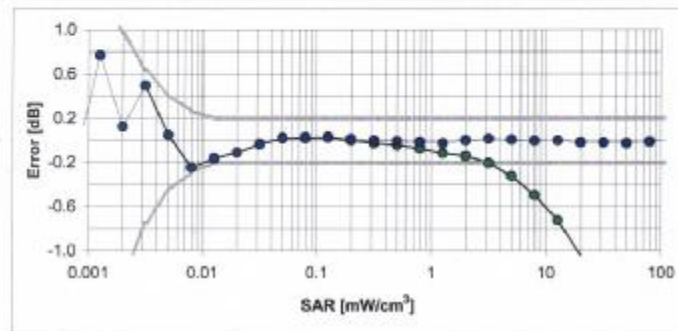
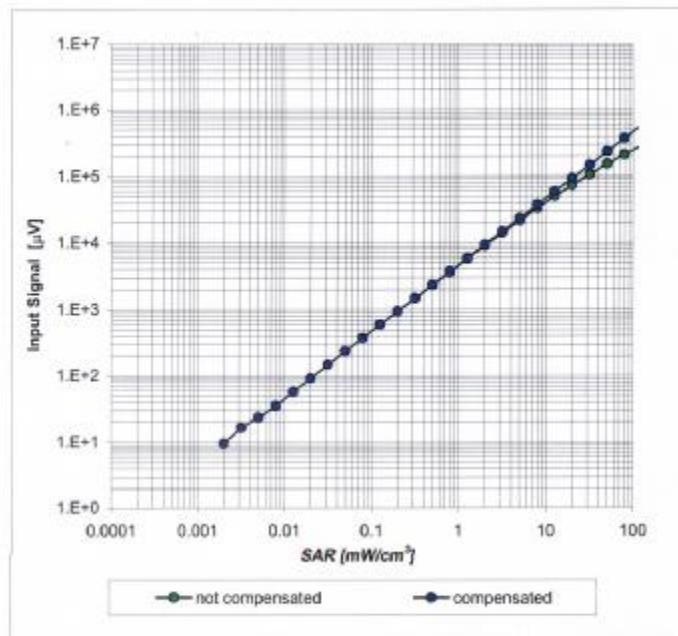

Uncertainty of Linearity Assessment: ± 0.6% (k=2)

ES3DV3 SN:3088

December 12, 2006

Conversion Factor Assessment

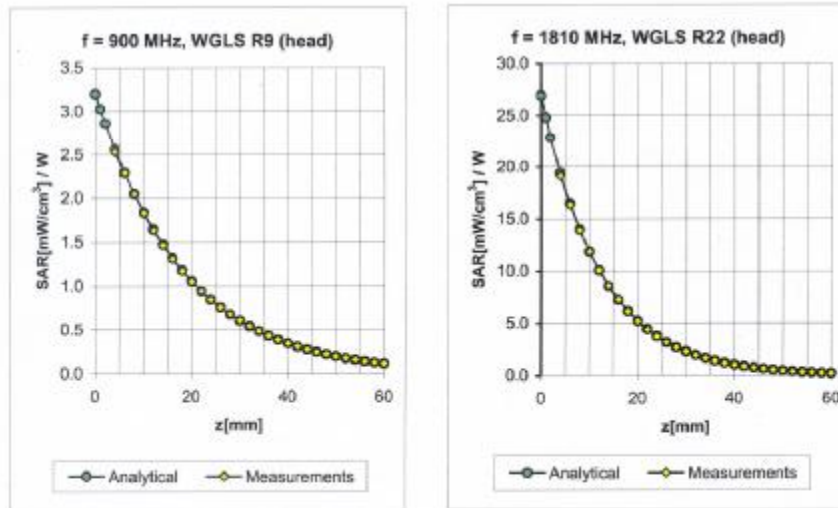

f [MHz]	Validity [MHz] ^c	TSL	Permittivity	Conductivity	Alpha	Depth	ConvF Uncertainty
900	± 50 / ± 100	Head	41.5 ± 5%	0.97 ± 5%	1.00	1.18	6.00 ± 11.0% (k=2)
1810	± 50 / ± 100	Head	40.0 ± 5%	1.40 ± 5%	0.73	1.39	5.07 ± 11.0% (k=2)
2000	± 50 / ± 100	Head	40.0 ± 5%	1.40 ± 5%	0.73	1.38	4.97 ± 11.0% (k=2)
2450	± 50 / ± 100	Head	39.2 ± 5%	1.80 ± 5%	0.74	1.36	4.69 ± 11.8% (k=2)
900	± 50 / ± 100	Body	55.0 ± 5%	1.05 ± 5%	1.00	1.17	5.92 ± 11.0% (k=2)
1810	± 50 / ± 100	Body	53.3 ± 5%	1.52 ± 5%	1.00	1.18	4.68 ± 11.0% (k=2)
2000	± 50 / ± 100	Body	53.3 ± 5%	1.52 ± 5%	0.89	1.27	4.51 ± 11.0% (k=2)
2450	± 50 / ± 100	Body	52.7 ± 5%	1.95 ± 5%	0.80	1.12	4.33 ± 11.8% (k=2)

^c The validity of ± 100 MHz only applies for DASY v4.4 and higher (see Page 2). The uncertainty is the RSS of the ConvF uncertainty at calibration frequency and the uncertainty for the indicated frequency band.

ES3DV3 SN:3088

December 12, 2006

Deviation from Isotropy in HSL

Error (ϕ , θ), $f = 900$ MHz

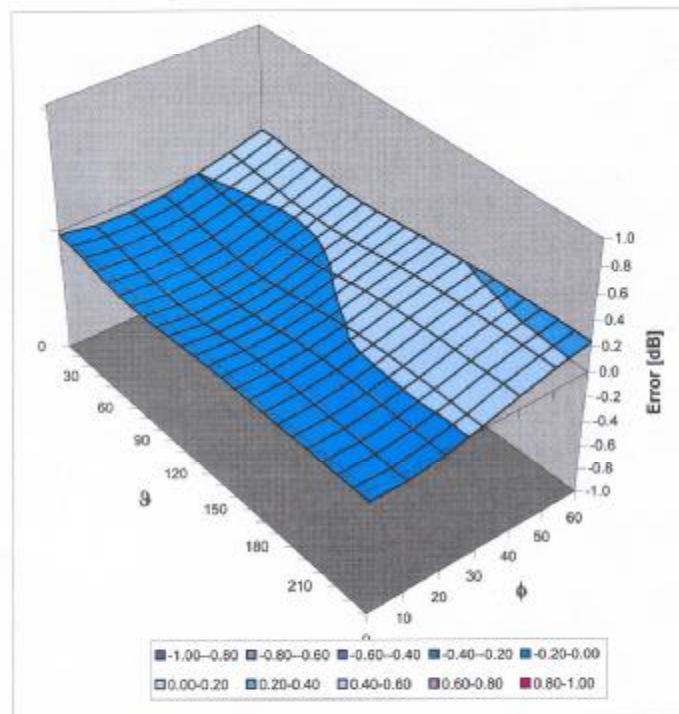

Uncertainty of Spherical Isotropy Assessment: $\pm 2.6\%$ ($k=2$)

6. DAE Calibration certification

Calibration Laboratory of
 Schmid & Partner
 Engineering AG
 Zeughausstrasse 43, 8004 Zurich, Switzerland



S Schweizerischer Kalibrierdienst
 C Service suisse d'étalonnage
 S Servizio svizzero di taratura
 S Swiss Calibration Service

Accredited by the Swiss Federal Office of Metrology and Accreditation
 The Swiss Accreditation Service is one of the signatories to the EA
 Multilateral Agreement for the recognition of calibration certificates

Accreditation No.: SCS 108

Client **SGS - CSTC (MTT)**

Certificate No: DAE3-569_Dec06

CALIBRATION CERTIFICATE

Object **DAE3 - SD 000 D03 AA - SN: 569**

Calibration procedure(s) **QA CAL-06.v12
 Calibration procedure for the data acquisition electronics (DAE)**

Calibration date: **December 8, 2006**

Condition of the calibrated item **In Tolerance**

This calibration certificate documents the traceability to national standards, which realize the physical units of measurements (SI).
 The measurements and the uncertainties with confidence probability are given on the following pages and are part of the certificate.

All calibrations have been conducted in the closed laboratory facility: environment temperature (22 ± 3)°C and humidity < 70%.

Calibration Equipment used (M&TE critical for calibration)

Primary Standards	ID #	Cal Date (Calibrated by, Certificate No.)	Scheduled Calibration
Fluke Process Calibrator Type 702	SN: 6295803	13-Oct-06 (Eical AG, No: 5492)	Oct-07
Keithley Multimeter Type 2001	SN: 0810278	03-Oct-06 (Eical AG, No: 5478)	Oct-07
Secondary Standards	ID #	Check Date (in house)	Scheduled Check
Calibrator Box V1.1	SE UMS 006 AB 1002	15-Jun-06 (SPEAG, in house check)	In house check Jun-07

Calibrated by:	Name Stefano Giannotti	Function Technician	Signature
Approved by:	Name Fin Bornholt	Function R&D Director	Signature

Issued: December 8, 2006

This calibration certificate shall not be reproduced except in full without written approval of the laboratory.

**Calibration Laboratory of
Schmid & Partner
Engineering AG**
Zeughausstrasse 43, 8004 Zurich, Switzerland



S Schweizerischer Kalibrierdienst
C Service suisse d'étalonnage
S Servizio svizzero di taratura
S Swiss Calibration Service

Accredited by the Swiss Federal Office of Metrology and Accreditation
The Swiss Accreditation Service is one of the signatories to the EA
Multilateral Agreement for the recognition of calibration certificates

Accreditation No.: **SCS 108**

Glossary

DAE data acquisition electronics
Connector angle information used in DASY system to align probe sensor X to the robot coordinate system.

Methods Applied and Interpretation of Parameters

- **DC Voltage Measurement:** Calibration Factor assessed for use in DASY system by comparison with a calibrated instrument traceable to national standards. The figure given corresponds to the full scale range of the voltmeter in the respective range.
- **Connector angle:** The angle of the connector is assessed measuring the angle mechanically by a tool inserted. Uncertainty is not required.
- The following parameters contain technical information as a result from the performance test and require no uncertainty.
- **DC Voltage Measurement Linearity:** Verification of the Linearity at +10% and -10% of the nominal calibration voltage. Influence of offset voltage is included in this measurement.
- **Common mode sensitivity:** Influence of a positive or negative common mode voltage on the differential measurement.
- **Channel separation:** Influence of a voltage on the neighbor channels not subject to an input voltage.
- **AD Converter Values with inputs shorted:** Values on the internal AD converter corresponding to zero input voltage
- **Input Offset Measurement:** Output voltage and statistical results over a large number of zero voltage measurements.
- **Input Offset Current:** Typical value for information; Maximum channel input offset current, not considering the input resistance.
- **Input resistance:** DAE input resistance at the connector, during internal auto-zeroing and during measurement.
- **Low Battery Alarm Voltage:** Typical value for information. Below this voltage, a battery alarm signal is generated.
- **Power consumption:** Typical value for information. Supply currents in various operating modes.

DC Voltage Measurement

A/D - Converter Resolution nominal

High Range: 1LSB = 6.1 μ V, full range = -100...+300 mV

Low Range: 1LSB = 61nV, full range = -1.....+3mV

DASY measurement parameters: Auto Zero Time: 3 sec; Measuring time: 3 sec

Calibration Factors	X	Y	Z
High Range	404.742 \pm 0.1% (k=2)	404.327 \pm 0.1% (k=2)	404.103 \pm 0.1% (k=2)
Low Range	3.93547 \pm 0.7% (k=2)	3.93513 \pm 0.7% (k=2)	3.93385 \pm 0.7% (k=2)

Connector Angle

Connector Angle to be used in DASY system	80 $^{\circ}$ \pm 1 $^{\circ}$
---	----------------------------------

Appendix**1. DC Voltage Linearity**

High Range	Input (μV)	Reading (μV)	Error (%)
Channel X + Input	200000	199999.9	0.00
Channel X + Input	20000	20002.27	0.01
Channel X - Input	20000	-19998.87	-0.01
Channel Y + Input	200000	200000.1	0.00
Channel Y + Input	20000	19999.20	0.00
Channel Y - Input	20000	-20003.47	0.02
Channel Z + Input	200000	200000.0	0.00
Channel Z + Input	20000	20001.01	0.01
Channel Z - Input	20000	-20001.46	0.01

Low Range	Input (μV)	Reading (μV)	Error (%)
Channel X + Input	2000	1999.9	0.00
Channel X + Input	200	199.91	-0.05
Channel X - Input	200	-200.86	0.43
Channel Y + Input	2000	1999.9	0.00
Channel Y + Input	200	199.35	-0.32
Channel Y - Input	200	-200.57	0.28
Channel Z + Input	2000	2000.1	0.00
Channel Z + Input	200	200.37	0.19
Channel Z - Input	200	-201.04	0.52

2. Common mode sensitivity

DASY measurement parameters: Auto Zero Time: 3 sec; Measuring time: 3 sec

	Common mode Input Voltage (mV)	High Range Average Reading (μV)	Low Range Average Reading (μV)
Channel X	200	-6.08	-11.00
	- 200	8.46	12.92
Channel Y	200	6.85	6.78
	- 200	-8.07	-8.07
Channel Z	200	-5.10	-5.59
	- 200	4.40	3.64

3. Channel separation

DASY measurement parameters: Auto Zero Time: 3 sec; Measuring time: 3 sec

	Input Voltage (mV)	Channel X (μV)	Channel Y (μV)	Channel Z (μV)
Channel X	200	-	0.47	0.37
Channel Y	200	1.04	-	3.88
Channel Z	200	-1.66	0.07	-

4. AD-Converter Values with inputs shorted

DASY measurement parameters: Auto Zero Time: 3 sec; Measuring time: 3 sec

	High Range (LSB)	Low Range (LSB)
Channel X	16395	15608
Channel Y	15744	16385
Channel Z	16312	16061

5. Input Offset Measurement

DASY measurement parameters: Auto Zero Time: 3 sec; Measuring time: 3 sec

Input 10M Ω

	Average (μ V)	min. Offset (μ V)	max. Offset (μ V)	Std. Deviation (μ V)
Channel X	0.16	-0.70	1.24	0.30
Channel Y	-1.80	-2.48	-0.86	0.32
Channel Z	-0.29	-1.19	0.92	0.39

6. Input Offset Current

Nominal input circuitry offset current on all channels: <25fA

7. Input Resistance

	Zeroing (M Ω m)	Measuring (M Ω m)
Channel X	200.2	0.2001
Channel Y	204.0	0.2001
Channel Z	205.8	0.2000

8. Low Battery Alarm Voltage (verified during pre test)

Typical values	Alarm Level (VDC)
Supply (+ Vcc)	+7.9
Supply (- Vcc)	-7.6

9. Power Consumption (verified during pre test)

Typical values	Switched off (mA)	Stand by (mA)	Transmitting (mA)
Supply (+ Vcc)	+0.0	+6	+14
Supply (- Vcc)	-0.01	-8	-9

7. Dipole Calibration certification

**Calibration Laboratory of
 Schmid & Partner
 Engineering AG**
 Zeughausstrasse 43, 8004 Zurich, Switzerland



S Schweizerischer Kalibrierdienst
S Service suisse d'étalonnage
C Servizio svizzero di taratura
S Swiss Calibration Service

Accredited by the Swiss Federal Office of Metrology and Accreditation
 The Swiss Accreditation Service is one of the signatories to the EA
 Multilateral Agreement for the recognition of calibration certificates

Accreditation No.: **SCS 108**

Client **SGS-CSTC (MTT)**

Certificate No: **D900V2-184_Dec06**

CALIBRATION CERTIFICATE			
Object	D900V2 - SN: 184		
Calibration procedure(s)	QA CAL-05.v6 Calibration procedure for dipole validation kits		
Calibration date:	December 8, 2006		
Condition of the calibrated item	In Tolerance		
<p>This calibration certificate documents the traceability to national standards, which realize the physical units of measurements (SI). The measurements and the uncertainties with confidence probability are given on the following pages and are part of the certificate.</p> <p>All calibrations have been conducted in the closed laboratory facility: environment temperature (22 ± 3)°C and humidity < 70%.</p> <p>Calibration Equipment used (M&TE critical for calibration)</p>			
Primary Standards	ID #	Cal Date (Calibrated by, Certificate No.)	Scheduled Calibration
Power meter EPM-442A	GB37480704	03-Oct-06 (METAS, No. 217-00608)	Oct-07
Power sensor HP 8481A	US37292783	03-Oct-06 (METAS, No. 217-00606)	Oct-07
Reference 20 dB Attenuator	SN: 5086 (20g)	10-Aug-06 (METAS, No 217-00591)	Aug-07
Reference 10 dB Attenuator	SN: 5047.2 (10r)	10-Aug-06 (METAS, No 217-00591)	Aug-07
Reference Probe ET3DV8 (HF)	SN 1507	19-Oct-06 (SPEAG, No. ET3-1507_Oct06)	Oct-07
D4E4	SN 601	15-Dec-05 (SPEAG, No. D4E4-601_Dec05)	Dec-06
Secondary Standards	ID #	Check Date (in house)	Scheduled Check
Power sensor HP 8481A	MY41092317	18-Oct-02 (SPEAG, in house check Oct-05)	In house check: Oct-07
RF generator Agilent E4421B	MY41000675	11-May-05 (SPEAG, in house check Nov-05)	In house check: Nov-07
Network Analyzer HP 8753E	US37390585 S4206	18-Oct-01 (SPEAG, in house check Oct-06)	In house check: Oct-07
Calibrated by:	Name Claudio Leubler	Function Laboratory Technician	Signature
Approved by:	Name Kerja Pokovic	Function Technical Manager	Signature
			Issued: December 8, 2006
This calibration certificate shall not be reproduced except in full without written approval of the laboratory.			

**Calibration Laboratory of
Schmid & Partner
Engineering AG**
Zeughausstrasse 43, 8004 Zurich, Switzerland



S Schweizerischer Kalibrierdienst
C Service suisse d'étalonnage
S Servizio svizzero di taratura
S Swiss Calibration Service

Accredited by the Swiss Federal Office of Metrology and Accreditation
The Swiss Accreditation Service is one of the signatories to the EA
Multilateral Agreement for the recognition of calibration certificates

Accreditation No.: **SCS 108**

Glossary:

TSL	tissue simulating liquid
ConvF	sensitivity in TSL / NORM x,y,z
N/A	not applicable or not measured

Calibration is Performed According to the Following Standards:

- IEEE Std 1528-2003, "IEEE Recommended Practice for Determining the Peak Spatial-Averaged Specific Absorption Rate (SAR) in the Human Head from Wireless Communications Devices: Measurement Techniques", December 2003
- CENELEC EN 50361, "Basic standard for the measurement of Specific Absorption Rate related to human exposure to electromagnetic fields from mobile phones (300 MHz - 3 GHz), July 2001
- Federal Communications Commission Office of Engineering & Technology (FCC OET), "Evaluating Compliance with FCC Guidelines for Human Exposure to Radiofrequency Electromagnetic Fields; Additional Information for Evaluating Compliance of Mobile and Portable Devices with FCC Limits for Human Exposure to Radiofrequency Emissions", Supplement C (Edition 01-01) to Bulletin 65

Additional Documentation:

- DASY4 System Handbook

Methods Applied and Interpretation of Parameters:

- Measurement Conditions:** Further details are available from the Validation Report at the end of the certificate. All figures stated in the certificate are valid at the frequency indicated.
- Antenna Parameters with TSL:** The dipole is mounted with the spacer to position its feed point exactly below the center marking of the flat phantom section, with the arms oriented parallel to the body axis.
- Feed Point Impedance and Return Loss:** These parameters are measured with the dipole positioned under the liquid filled phantom. The impedance stated is transformed from the measurement at the SMA connector to the feed point. The Return Loss ensures low reflected power. No uncertainty required.
- Electrical Delay:** One-way delay between the SMA connector and the antenna feed point. No uncertainty required.
- SAR measured:** SAR measured at the stated antenna input power.
- SAR normalized:** SAR as measured, normalized to an input power of 1 W at the antenna connector.
- SAR for nominal TSL parameters:** The measured TSL parameters are used to calculate the nominal SAR result.

Measurement Conditions

DASY system configuration, as far as not given on page 1.

DASY Version	DASY4	V4.7
Extrapolation	Advanced Extrapolation	
Phantom	Modular Flat Phantom V4.9	
Distance Dipole Center - TSL	15 mm	with Spacer
Zoom Scan Resolution	dx, dy, dz = 5 mm	
Frequency	900 MHz \pm 1 MHz	

Head TSL parameters

The following parameters and calculations were applied.

	Temperature	Permittivity	Conductivity
Nominal Head TSL parameters	22.0 °C	41.5	0.97 mho/m
Measured Head TSL parameters	(22.0 \pm 0.2) °C	40.8 \pm 6 %	0.97 mho/m \pm 6 %
Head TSL temperature during test	(21.7 \pm 0.2) °C	---	---

SAR result with Head TSL

SAR averaged over 1 cm ³ (1 g) of Head TSL	Condition	
SAR measured	250 mW input power	2.72 mW / g
SAR normalized	normalized to 1W	10.9 mW / g
SAR for nominal Head TSL parameters ¹	normalized to 1W	10.8 mW / g \pm 17.0 % (k=2)

SAR averaged over 10 cm ³ (10 g) of Head TSL	condition	
SAR measured	250 mW input power	1.75 mW / g
SAR normalized	normalized to 1W	7.00 mW / g
SAR for nominal Head TSL parameters ¹	normalized to 1W	6.95 mW / g \pm 16.5 % (k=2)

¹ Correction to nominal TSL parameters according to d), chapter "SAR Sensitivities"

Body TSL parameters

The following parameters and calculations were applied.

	Temperature	Permittivity	Conductivity
Nominal Body TSL parameters	22.0 °C	55.0	1.05 mho/m
Measured Body TSL parameters	(22.0 ± 0.2) °C	53.4 ± 6 %	1.05 mho/m ± 6 %
Body TSL temperature during test	(21.6 ± 0.2) °C	---	---

SAR result with Body TSL

SAR averaged over 1 cm ³ (1 g) of Body TSL	condition	
SAR measured	250 mW input power	2.75 mW / g
SAR normalized	normalized to 1W	11.0 mW / g
SAR for nominal Body TSL parameters ²	normalized to 1W	10.8 mW / g ± 17.0 % (k=2)

SAR averaged over 10 cm ³ (10 g) of Body TSL	condition	
SAR measured	250 mW input power	1.79 mW / g
SAR normalized	normalized to 1W	7.16 mW / g
SAR for nominal Body TSL parameters ²	normalized to 1W	7.05 mW / g ± 16.5 % (k=2)

² Correction to nominal TSL parameters according to d), chapter "SAR Sensitivities"

Appendix

Antenna Parameters with Head TSL

Impedance, transformed to feed point	50.8 Ω - 6.2 j Ω
Return Loss	- 24.2 dB

Antenna Parameters with Body TSL

Impedance, transformed to feed point	46.7 Ω - 8.3 j Ω
Return Loss	- 20.7 dB

General Antenna Parameters and Design

Electrical Delay (one direction)	1.411 ns
----------------------------------	----------

After long term use with 100W radiated power, only a slight warming of the dipole near the feedpoint can be measured.

The dipole is made of standard semirigid coaxial cable. The center conductor of the feeding line is directly connected to the second arm of the dipole. The antenna is therefore short-circuited for DC-signals.

No excessive force must be applied to the dipole arms, because they might bend or the soldered connections near the feedpoint may be damaged.

Additional EUT Data

Manufactured by	SPEAG
Manufactured on	April 01, 2003

DASY4 Validation Report for Head TSL

Date/Time: 05.12.2006 17:14:04

Test Laboratory: SPEAG, Zurich, Switzerland

DUT: Dipole 900 MHz; Type: D900V2; Serial: D900V2 - SN:184

Communication System: CW; Frequency: 900 MHz; Duty Cycle: 1:1

Medium: HSL 900 MHz;

Medium parameters used: $f = 900$ MHz; $\sigma = 0.969$ mho/m; $\epsilon_r = 40.7$; $\rho = 1000$ kg/m³

Phantom section: Flat Section

Measurement Standard: DASY4 (High Precision Assessment)

DASY4 Configuration:

- Probe: ET3DV6 - SN1507 (HF); ConvF(6.01, 6.01, 6.01); Calibrated: 19.10.2006
- Sensor-Surface: 4mm (Mechanical Surface Detection)
- Electronics: DAE4 Sn601; Calibrated: 15.12.2005
- Phantom: Flat Phantom 4.9L; Type: QD00P49AA; ;
- Measurement SW: DASY4, V4.7 Build 46; Postprocessing SW: SEMCAD, V1.8 Build 171

Pin = 250 mW; d = 15 mm/Zoom Scan (7x7x7)/Cube 0:

Measurement grid: dx=5mm, dy=5mm, dz=5mm

Reference Value = 57.4 V/m; Power Drift = -0.013 dB

Peak SAR (extrapolated) = 4.01 W/kg

SAR(1 g) = 2.72 mW/g; SAR(10 g) = 1.75 mW/g

Maximum value of SAR (measured) = 2.96 mW/g

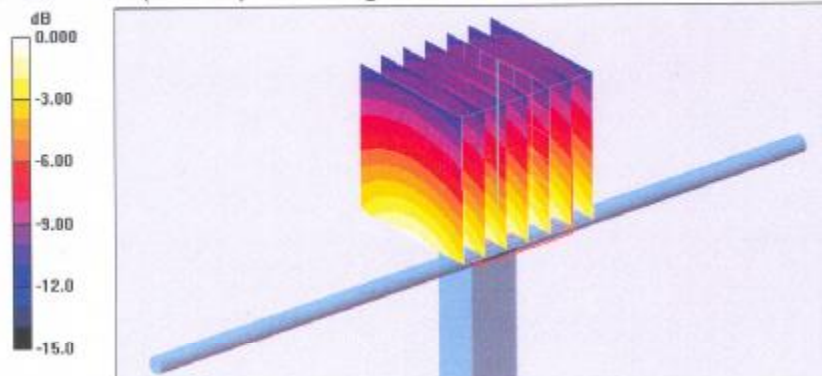

Impedance Measurement Plot for Head TSL

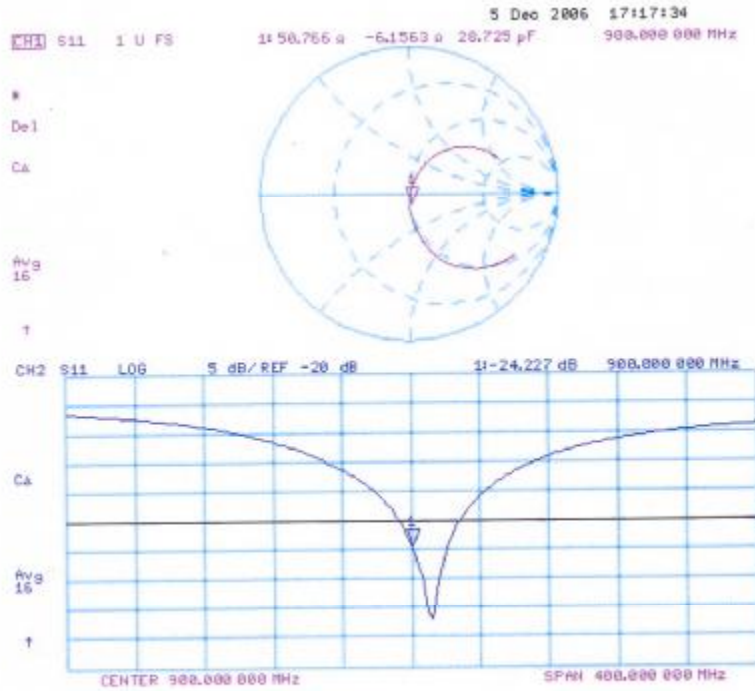

DASY4 Validation Report for Body TSL

Date/Time: 06.12.2006 15:53:38

Test Laboratory: SPEAG, Zurich, Switzerland

DUT: Dipole 900 MHz; Type: D900V2; Serial: D900V2 - SN:184

Communication System: CW; Frequency: 900 MHz; Duty Cycle: 1:1

Medium: MSL900;

Medium parameters used: $f = 900$ MHz; $\sigma = 1.05$ mho/m; $\epsilon_r = 53.4$; $\rho = 1000$ kg/m³

Phantom section: Flat Section

Measurement Standard: DASY4 (High Precision Assessment)

DASY4 Configuration:

- Probe: ET3DV6 - SN1507 (HF); ConvF(5.8, 5.8, 5.8); Calibrated: 19.10.2006
- Sensor-Surface: 4mm (Mechanical Surface Detection)
- Electronics: DAE4 Sn601; Calibrated: 15.12.2005
- Phantom: Flat Phantom 4.9L; Type: QD000P49AA; ;
- Measurement SW: DASY4, V4.7 Build 46; Postprocessing SW: SEMCAD, V1.8 Build 171

Pin = 250 mW; d = 15 mm/Zoom Scan (7x7x7)/Cube 0:

Measurement grid: dx=5mm, dy=5mm, dz=5mm

Reference Value = 56.1 V/m; Power Drift = 0.006 dB

Peak SAR (extrapolated) = 3.89 W/kg

SAR(1 g) = 2.75 mW/g; SAR(10 g) = 1.79 mW/g

Maximum value of SAR (measured) = 3.00 mW/g

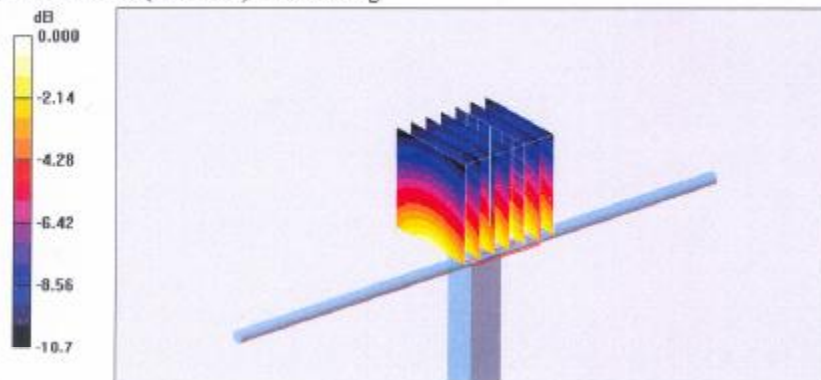

Impedance Measurement Plot for Body TSL

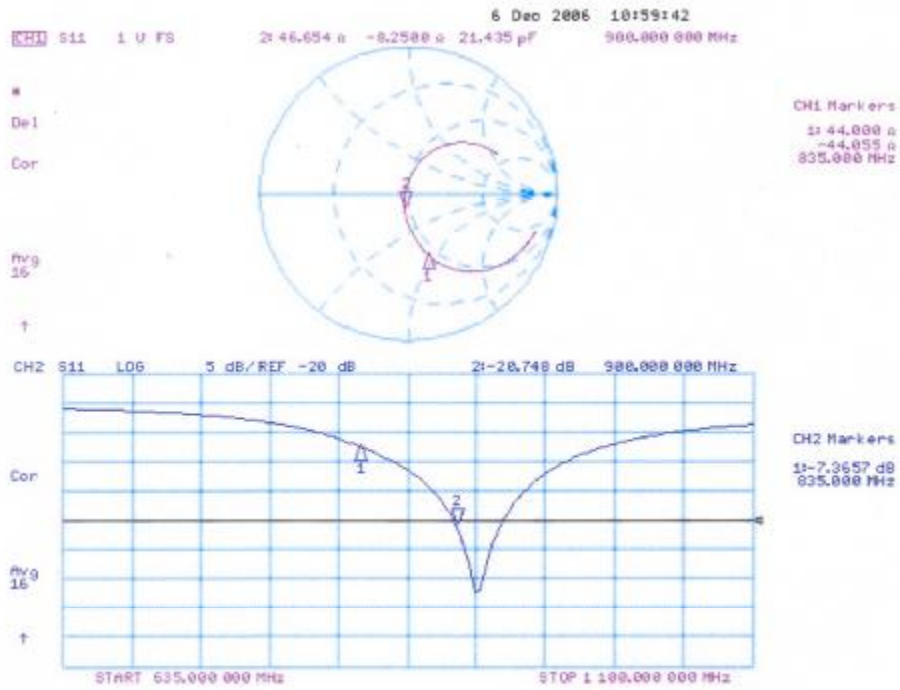

**Calibration Laboratory of
 Schmid & Partner
 Engineering AG**
 Zeughausstrasse 43, 8004 Zurich, Switzerland



S Schweizerischer Kalibrierdienst
S Service suisse d'étalonnage
C Servizio svizzero di taratura
S Swiss Calibration Service

Accredited by the Swiss Federal Office of Metrology and Accreditation
 The Swiss Accreditation Service is one of the signatories to the EA
 Multilateral Agreement for the recognition of calibration certificates

Accreditation No.: **SCS 108**

Client **SGS-CSTC (MTT)**

Certificate No: **D1900V2-5d028_Dec06**

CALIBRATION CERTIFICATE

Object **D1900V2 - SN: 5d028**

Calibration procedure(s) **QA CAL-05.v6
 Calibration procedure for dipole validation kits**

Calibration date: **December 12, 2006**

Condition of the calibrated item **In Tolerance**

This calibration certificate documents the traceability to national standards, which realize the physical units of measurements (SI).
 The measurements and the uncertainties with confidence probability are given on the following pages and are part of the certificate.

All calibrations have been conducted in the closed laboratory facility: environment temperature (22 ± 3)°C and humidity < 70%.

Calibration Equipment used (M&TE critical for calibration)

Primary Standards	ID #	Cal Date (Calibrated by, Certificate No.)	Scheduled Calibration
Power meter EPM-442A	GB37480704	03-Oct-06 (METAS, No. 217-00608)	Oct-07
Power sensor HP 8481A	US37292783	03-Oct-06 (METAS, No. 217-00608)	Oct-07
Reference 20 dB Attenuator	SN: 5066 (20g)	10-Aug-06 (METAS, No 217-00591)	Aug-07
Reference 10 dB Attenuator	SN: 5047.2 (10r)	10-Aug-06 (METAS, No 217-00591)	Aug-07
Reference Probe ET3DV6	SN: 1507	19-Oct-06 (SPEAG, No. ET3-1507_Oct06)	Oct-07
Reference Probe ES3DV3	SN: 3025	19-Oct-06 (SPEAG, No. ES3-3025_Oct06)	Oct-07
DAE4	SN: 601	15-Dec-05 (SPEAG, No. DAE4-601_Dec05)	Dec-06
Secondary Standards	ID #	Check Date (in house)	Scheduled Check
Power sensor HP 8481A	MY41092317	18-Oct-02 (SPEAG, in house check Oct-05)	In house check: Oct-07
RF generator Agilent E4421B	MY41000675	11-May-05 (SPEAG, in house check Nov-05)	In house check: Nov-07
Network Analyzer HP 8753E	US37390585 S4206	18-Oct-01 (SPEAG, in house check Oct-06)	In house check: Oct-07

Calibrated by: **Name** Mike Meili **Function** Laboratory Technician **Signature** *M. Meili*

Approved by: **Name** Katja Pokovic **Function** Technical Manager **Signature** *Katja Pokovic*

Issued: December 14, 2006

This calibration certificate shall not be reproduced except in full without written approval of the laboratory.

**Calibration Laboratory of
Schmid & Partner
Engineering AG**
Zeughausstrasse 43, 8004 Zurich, Switzerland



S Schweizerischer Kalibrierdienst
C Service suisse d'étalonnage
S Servizio svizzero di taratura
S Swiss Calibration Service

Accredited by the Swiss Federal Office of Metrology and Accreditation
The Swiss Accreditation Service is one of the signatories to the EA
Multilateral Agreement for the recognition of calibration certificates

Accreditation No.: **SCS 108**

Glossary:

TSL tissue simulating liquid
ConvF sensitivity in TSL / NORM x,y,z
N/A not applicable or not measured

Calibration is Performed According to the Following Standards:

- a) IEEE Std 1528-2003, "IEEE Recommended Practice for Determining the Peak Spatial-Averaged Specific Absorption Rate (SAR) in the Human Head from Wireless Communications Devices: Measurement Techniques", December 2003
- b) CENELEC EN 50361, "Basic standard for the measurement of Specific Absorption Rate related to human exposure to electromagnetic fields from mobile phones (300 MHz - 3 GHz), July 2001
- c) Federal Communications Commission Office of Engineering & Technology (FCC OET), "Evaluating Compliance with FCC Guidelines for Human Exposure to Radiofrequency Electromagnetic Fields; Additional Information for Evaluating Compliance of Mobile and Portable Devices with FCC Limits for Human Exposure to Radiofrequency Emissions", Supplement C (Edition 01-01) to Bulletin 65

Additional Documentation:

- d) DASY4 System Handbook

Methods Applied and Interpretation of Parameters:

- *Measurement Conditions:* Further details are available from the Validation Report at the end of the certificate. All figures stated in the certificate are valid at the frequency indicated.
- *Antenna Parameters with TSL:* The dipole is mounted with the spacer to position its feed point exactly below the center marking of the flat phantom section, with the arms oriented parallel to the body axis.
- *Feed Point Impedance and Return Loss:* These parameters are measured with the dipole positioned under the liquid filled phantom. The impedance stated is transformed from the measurement at the SMA connector to the feed point. The Return Loss ensures low reflected power. No uncertainty required.
- *Electrical Delay:* One-way delay between the SMA connector and the antenna feed point. No uncertainty required.
- *SAR measured:* SAR measured at the stated antenna input power.
- *SAR normalized:* SAR as measured, normalized to an input power of 1 W at the antenna connector.
- *SAR for nominal TSL parameters:* The measured TSL parameters are used to calculate the nominal SAR result.

Measurement Conditions

DASY system configuration, as far as not given on page 1.

DASY Version	DASY4	V4.7
Extrapolation	Advanced Extrapolation	
Phantom	Modular Flat Phantom V5.0	
Distance Dipole Center - TSL	10 mm	with Spacer
Area Scan Resolution	dx, dy = 15 mm	
Zoom Scan Resolution	dx, dy, dz = 5 mm	
Frequency	1900 MHz \pm 1 MHz	

Head TSL parameters

The following parameters and calculations were applied.

	Temperature	Permittivity	Conductivity
Nominal Head TSL parameters	22.0 °C	40.0	1.40 mho/m
Measured Head TSL parameters	(22.0 \pm 0.2) °C	38.4 \pm 6 %	1.40 mho/m \pm 6 %
Head TSL temperature during test	(21.2 \pm 0.2) °C	---	---

SAR result with Head TSL

SAR averaged over 1 cm ³ (1 g) of Head TSL	condition	
SAR measured	250 mW input power	9.36 mW / g
SAR normalized	normalized to 1W	37.4 mW / g
SAR for nominal Head TSL parameters ¹	normalized to 1W	36.6 mW / g \pm 17.0 % (k=2)

SAR averaged over 10 cm ³ (10 g) of Head TSL	Condition	
SAR measured	250 mW input power	4.96 mW / g
SAR normalized	normalized to 1W	19.8 mW / g
SAR for nominal Head TSL parameters ¹	normalized to 1W	19.5 mW / g \pm 16.5 % (k=2)

¹ Correction to nominal TSL parameters according to d), chapter "SAR Sensitivities"

Body TSL parameters

The following parameters and calculations were applied.

	Temperature	Permittivity	Conductivity
Nominal Body TSL parameters	22.0 °C	53.3	1.52 mho/m
Measured Body TSL parameters	(22.0 ± 0.2) °C	51.8 ± 6 %	1.54 mho/m ± 6 %
Body TSL temperature during test	(21.8 ± 0.2) °C	---	---

SAR result with Body TSL

SAR averaged over 1 cm ³ (1 g) of Body TSL	Condition	
SAR measured	250 mW input power	9.50 mW / g
SAR normalized	normalized to 1W	38.0 mW / g
SAR for nominal Body TSL parameters ²	normalized to 1W	37.0 mW / g ± 17.0 % (k=2)

SAR averaged over 10 cm ³ (10 g) of Body TSL	condition	
SAR measured	250 mW input power	5.05 mW / g
SAR normalized	normalized to 1W	20.2 mW / g
SAR for nominal Body TSL parameters ²	normalized to 1W	19.8 mW / g ± 16.5 % (k=2)

² Correction to nominal TSL parameters according to d), chapter "SAR Sensitivities"

Appendix

Antenna Parameters with Head TSL

Impedance, transformed to feed point	54.8 Ω + 4.5 j Ω
Return Loss	- 24.1 dB

Antenna Parameters with Body TSL

Impedance, transformed to feed point	51.2 Ω + 6.6 j Ω
Return Loss	- 23.6 dB

General Antenna Parameters and Design

Electrical Delay (one direction)	1.197 ns
----------------------------------	----------

After long term use with 100W radiated power, only a slight warming of the dipole near the feedpoint can be measured.

The dipole is made of standard semirigid coaxial cable. The center conductor of the feeding line is directly connected to the second arm of the dipole. The antenna is therefore short-circuited for DC-signals.
No excessive force must be applied to the dipole arms, because they might bend or the soldered connections near the feedpoint may be damaged.

Additional EUT Data

Manufactured by	SPEAG
Manufactured on	December 17, 2002

DASY4 Validation Report for Head TSL

Date/Time: 11.12.2006 18:50:48

Test Laboratory: SPEAG, Zurich, Switzerland

DUT: Dipole 1900 MHz; Type: D1900V2; Serial: D1900V2 - SN:5d028

Communication System: CW; Frequency: 1900 MHz; Duty Cycle: 1:1

Medium: HSL U10 BB;

Medium parameters used: $f = 1900$ MHz; $\sigma = 1.4$ mho/m; $\epsilon_r = 38.4$; $\rho = 1000$ kg/m³

Phantom section: Flat Section

Measurement Standard: DASY4 (High Precision Assessment)

DASY4 Configuration:

- Probe: ET3DV6 - SN1507 (HF); ConvF(4.97, 4.97, 4.97); Calibrated: 19.10.2006
- Sensor-Surface: 4mm (Mechanical Surface Detection)
- Electronics: DAE4 Sn601; Calibrated: 15.12.2005
- Phantom: Flat Phantom 5.0 (front); Type: QD000P50AA
- Measurement SW: DASY4, V4.7 Build 44; Postprocessing SW: SEMCAD, V1.8 Build 171

Pin = 250 mW; d = 10 mm/Area Scan (101x101x1):

Measurement grid: dx=10mm, dy=10mm

Maximum value of SAR (interpolated) = 10.6 mW/g

Pin = 250 mW; d = 10 mm/Zoom Scan (7x7x7)/Cube 0:

Measurement grid: dx=5mm, dy=5mm, dz=5mm

Reference Value = 86.6 V/m; Power Drift = 0.033 dB

Peak SAR (extrapolated) = 15.9 W/kg

SAR(1 g) = 9.36 mW/g; SAR(10 g) = 4.96 mW/g

Maximum value of SAR (measured) = 10.6 mW/g

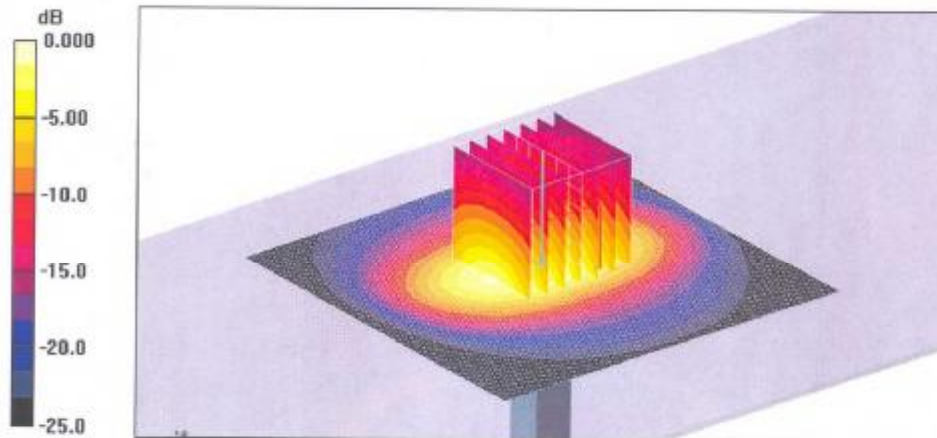

0 dB = 10.6mW/g

Impedance Measurement Plot for Head TSL

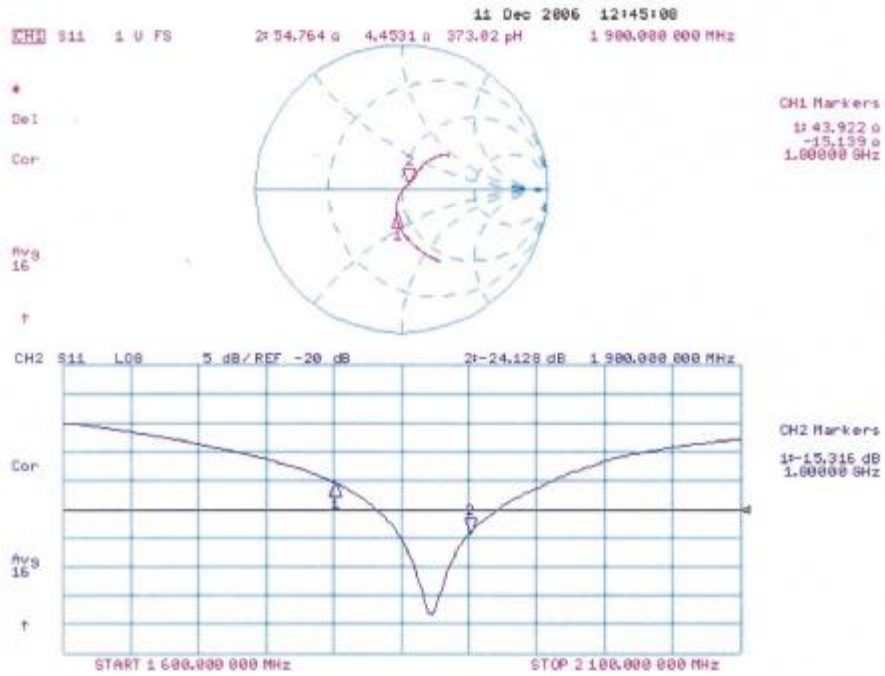

DASY4 Validation Report for Body TSL

Date/Time: 12.12.2006 16:43:40

Test Laboratory: SPEAG, Zurich, Switzerland

DUT: Dipole 1900 MHz; Type: D1900V2; Serial: D1900V2 - SN:5d028

Communication System: CW; Frequency: 1900 MHz; Duty Cycle: 1:1

Medium: MSL U10 BB;

Medium parameters used: $f = 1900$ MHz; $\sigma = 1.54$ mho/m; $\epsilon_r = 51.8$; $\rho = 1000$ kg/m³

Phantom section: Flat Section

Measurement Standard: DASY4 (High Precision Assessment)

DASY4 Configuration:

- Probe: ET3DV6 - SN1507 (HF); ConvF(4.43, 4.43, 4.43); Calibrated: 19.10.2006
- Sensor-Surface: 4mm (Mechanical Surface Detection)
- Electronics: DAE4 Sn601; Calibrated: 15.12.2005
- Phantom: Flat Phantom 5.0 (front); Type: QD000P50AA
- Measurement SW: DASY4, V4.7 Build 44; Postprocessing SW: SEMCAD, V1.8 Build 171

Pin = 250 mW; d = 10 mm/Zoom Scan (7x7x7)/Cube 0:

Measurement grid: dx=5mm, dy=5mm, dz=5mm

Reference Value = 89.1 V/m; Power Drift = 0.027 dB

Peak SAR (extrapolated) = 16.2 W/kg

SAR(1 g) = 9.5 mW/g; SAR(10 g) = 5.05 mW/g

Maximum value of SAR (measured) = 10.4 mW/g

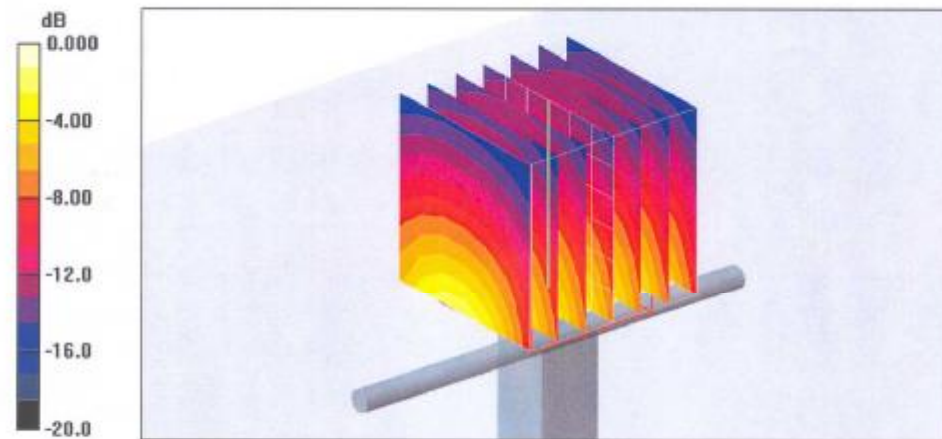

**
0 dB = 10.4mW/g

Impedance Measurement Plot for Body TSL

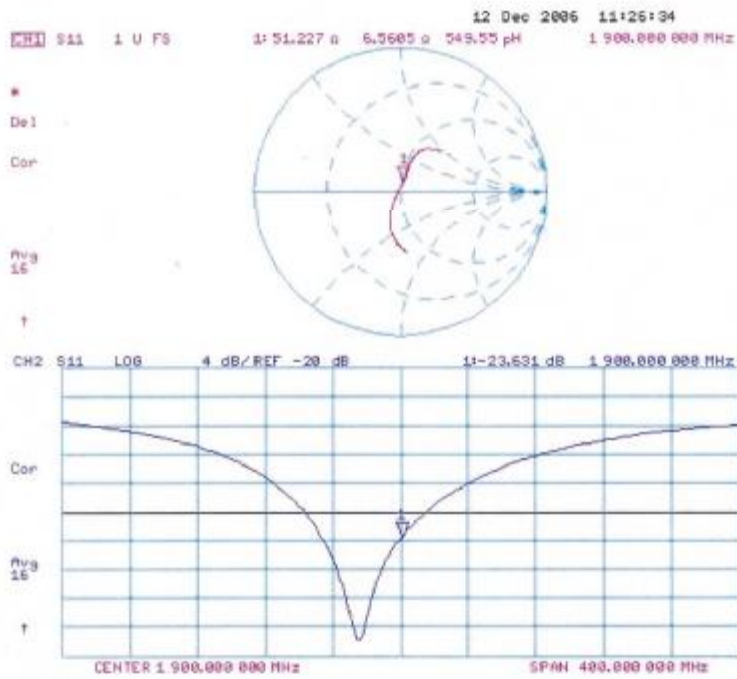

8. Uncertainty analysis

Error Description	Tol. (± %)	Prob. dist.	Div.	(c_1) (1g)	(c_2) (10g)	Std. unc. (± %)		(v_i)
						(1g)	(10g)	
Measurement System								
Probe Calibration	4.8	N	1	1	1	4.8	4.8	∞
Axial Isotropy	4.7	R	$\sqrt{3}$	1	1	2.7	2.7	∞
Hemispherical Isotropy	0	R	$\sqrt{3}$	1	1	0	0	∞
Boundary Effects	1.0	R	$\sqrt{3}$	1	1	0.6	0.6	∞
Linearity	4.7	R	$\sqrt{3}$	1	1	2.7	2.7	∞
System Detection Limit	1.0	R	$\sqrt{3}$	1	1	0.6	0.6	∞
Readout Electronics	1.0	N	1	1	1	1.0	1.0	∞
Response Time	0	R	$\sqrt{3}$	1	1	0	0	∞
Integration Time	0	R	$\sqrt{3}$	1	1	0	0	∞
RF Ambient Conditions	3.0	R	$\sqrt{3}$	1	1	1.7	1.7	∞
Probe Positioner	0.4	R	$\sqrt{3}$	1	1	0.2	0.2	∞
Probe Positioning	2.9	R	$\sqrt{3}$	1	1	1.7	1.7	∞
Algorithms for Max. SAR Eval.	1.0	R	$\sqrt{3}$	1	1	0.6	0.6	∞
Dipole								
Dipole Axis to Liquid Distance	2.0	R	$\sqrt{3}$	1	1	1.2	1.2	∞
Input power and SAR drift meas.	4.7	R	$\sqrt{3}$	1	1	2.7	2.7	∞
Phantom and Tissue Param.								
Phantom Uncertainty	4.0	R	$\sqrt{3}$	1	1	2.3	2.3	∞
Liquid Conductivity (target)	5.0	R.	$\sqrt{3}$	0.64	0.43	1.8	1.2	∞
Liquid Conductivity (meas.)	2.5	N	1	0.64	0.43	1.6	1.1	∞
Liquid Permittivity (target)	5.0	R	$\sqrt{3}$	0.6	0.49	1.7	1.4	∞
Liquid Permittivity (meas.)	2.5	N	1	0.6	0.49	1.5	1.2	∞
Combined Standard Uncertainty						8.4	8.1	∞
Coverage Factor for 95%		kp=2						
Expanded Uncertainty						16.8	16.2	

Dasy4 Uncertainty Budget

9. Phantom description

Schmid & Partner Engineering AG

Zeughausstrasse 43, 8004 Zurich, Switzerland, Phone +41 1 245 97 00, Fax +41 1 245 97 79

Certificate of conformity / First Article Inspection

Item	SAM Twin Phantom V4.0
Type No	QD 000 P40 CA
Series No	TP-1150 and higher
Manufacturer / Origin	Unterse Composite Hauptstr. 69 CH-8559 Fruthwilen Switzerland

Tests

The series production process used allows the limitation to test of first articles. Complete tests were made on the pre-series Type No. QD 000 P40 AA, Serial No. TP-1001 and on the series first article Type No. QD 000 P40 BA, Serial No. TP-1006. Certain parameters have been retested using further series units (called samples).

Test	Requirement	Details	Units tested
Shape	Compliance with the geometry according to the CAD model.	ITIS CAD File (*)	First article, Samples
Material thickness	Compliant with the requirements according to the standards	2mm +/- 0.2mm in specific areas	First article, Samples
Material parameters	Dielectric parameters for required frequencies	200 MHz - 3 GHz Relative permittivity < 5 Loss tangent < 0.05.	Material sample TP 104-5
Material resistivity	The material has been tested to be compatible with the liquids defined in the standards	Liquid type HSL 1800 and others according to the standard.	Pre-series, First article

Standards

- [1] CENELEC EN 50361
- [2] IEEE P1528-200x draft 6.5
- [3] IEC PT 62209 draft 0.9
- (*) The ITIS CAD file is derived from [2] and is also within the tolerance requirements of the shapes of [1] and [3].

Conformity

Based on the sample tests above, we certify that this item is in compliance with the uncertainty requirements of SAR measurements specified in standard [1] and draft standards [2] and [3].

Date

28.02.2002

Signature / Stamp

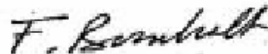

**Schmid & Partner
Engineering AG**

Zeughausstrasse 43, CH-8004 Zurich
Tel. +41 1 245 97 00, Fax +41 1 245 97 79

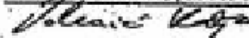

End of Report