

SAR TEST REPORT

Equipment Under Test :	GSM 850&PCS1900MHz MOBILE PHONE
Model No. :	CVLE6 Crystal
Market name:	OT-E230a
FCC ID:	RAD048
Applicant :	T&A mobile phones
Address of Applicant :	C district, 4, Digital technology area, Gaoxin nan rd, Shenzhen
Date of Receipt :	2006.11.07
Date of Test :	2006.11.08 – 2006.11.27
Date of Issue :	2006.11.28

Standards

FCC OET Bulletin 65 supplement C, ANSI/IEEE C95.1, C95.3, IEEE 1528-2003

In the configuration tested, the EUT complied with the standards specified above.

Remarks:

This report details the results of the testing carried out on one sample, the results contained in this test report do not relate to other samples of the same product. The manufacturer should ensure that all products in series production are in conformity with the product sample detailed in this report.

This report may only be reproduced and distributed in full. If the product in this report is used in any configuration other than that detailed in the report, the manufacturer must ensure the new system complies with all relevant standards. Any mention of SGS-CSTC Shanghai GSM Lab or testing done by SGS-CSTC Shanghai GSM Lab must approve SGS Shanghai GSM Lab in connection with distribution or use of the product described in this report in writing.

Tested by :



Date :

2006.11.28

Approved by :

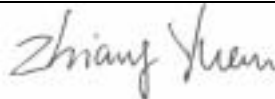

Date :

2006.11.28

Contents

1. General Information	5
1.1 Test Laboratory	5
1.2 Details of Applicant.....	5
1.3 Description of EUT(s)	5
1.4 Test Environment	6
1.5 Operation Configuration.....	6
1.6 The SAR Measurement System	6
1.7 SAR System Verification	8
1.8 Tissue Simulant Fluid for the Frequency Band 850MHz and 1900MHZ.....	9
1.9 Test Standards and Limits.....	10
2. Summary of Results.....	11
3. Instruments List	12
4. Measurements	14
4.1 LeftHandSide-Cheek-GSM850-Low.....	14
GSM850-LeftHandSide-Cheek-Low	14
4.2 LeftHandSide-Cheek-GSM850-Middle	15
GSM850-LeftHandSide-Cheek-Middle.....	15
4.3 LeftHandSide-Cheek-GSM850-High.....	17
GSM850-LeftHandSide-Cheek-High	17
4.4 LeftHandSide-Tilt-GSM850-Low	19
GSM850-LeftHandSide-Tilt-Low	19
4.5 LeftHandSide-Tilt-GSM850-Middle.....	21
GSM850-LeftHandSide-Tilt-Middle	21
4.6 LeftHandSide-Tilt-GSM850-High	23
GSM850-LeftHandSide-Tilt-High.....	23
4.7 RightHandSide-Cheek-GSM850-Low.....	25
GSM850-RightHandSide-Cheek-Low.....	25
4.8 RightHandSide-Cheek-GSM850-Middle.....	27
GSM850-RightHandSide-Cheek-Middle	27
4.9 RightHandSide-Cheek-GSM850-High	29
GSM850-RightHandSide-Cheek-High.....	29
4.10 RightHandSide-Tilt-GSM850-Low	31

GSM850-RightHandSide-Tilt-Low	31
4.11 RightHandSide-Tilt-GSM850-Middle	33
GSM850-RightHandSide-Tilt-Middle	33
4.12 RightHandSide-Tilt-GSM850-High	35
GSM850-RightHandSide-Tilt-High.....	35
4.13 Body-Worn-GSM850-Low	37
GSM850-Body-Worn-Low-1.5cm.....	37
4.14 Body-Worn-GSM850-Middle	39
GSM850-Body-Worn-Middle-1.5cm.....	39
4.15 Body-Worn-GSM850-High	41
GSM850-Body-Worn-High-1.5cm	41
4.16 LeftHandSide-Cheek-PCS1900-Low	43
PCS1900-LeftHandSide-Cheek-Low	43
4.17 LeftHandSide-Cheek-PCS1900-Middle	45
PCS1900-LeftHandSide-Cheek-Middle	45
4.18 LeftHandSide-Cheek-PCS1900-High.....	46
PCS1900-LeftHandSide-Cheek-High.....	46
4.19 LeftHandSide-Tilt-PCS1900-Low	47
PCS1900-LeftHandSide-Tilt-Low	48
4.20 LeftHandSide-Tilt-PCS1900-Middle.....	49
PCS1900-LeftHandSide-Tilt-Middle.....	49
4.21 LeftHandSide-Tilt-PCS1900-High	51
PCS1900-LeftHandSide-Tilt-High	51
4.22 RightHandSide-Cheek-PCS1900-Low.....	53
PCS1900-RightHandSide-Cheek-Low	53
4.23 RightHandSide-Cheek-PCS1900-Middle	55
PCS1900-RightHandSide-Cheek-Middle	55
4.24 RightHandSide-Cheek-PCS1900-High	57
PCS1900-RightHandSide-Cheek-High.....	57
4.25 RightHandSide-Tilt-PCS1900-Low	59
PCS1900-RightHandSide-Tilt-Low	59
4.26 RightHandSide-Tilt-PCS1900-Middle	61
PCS1900-RightHandSide-Tilt-Middle.....	61
4.27 RightHandSide-Tilt-PCS1900-High	63
PCS1900-RightHandSide-Tilt-High	63

4.28 Body-Worn-PCS1900-Low	65
PCS1900-Body-Worn-Low-1.5cm	65
4.29 Body-Worn-PCS1900-Middle	67
PCS1900-Body-Worn-Middle-1.5cm	67
4.30 Body-Worn-PCS1900-High	69
PCS1900-Body-Worn-High-1.5cm	69
Appendix	71
Appendix	71
1. Photographs of Test Setup	71
2. Photographs of the EUT	74
3. Photographs of the battery	74
4. Photograph of the charger	75
5. Probe Calibration certification	76
6. Uncertainty analysis	77
7. Phantom description	78

1. General Information

1.1 Test Laboratory

GSM Lab
 SGS-CSTC Standards Technical Services Co.Ltd Shanghai Branch
 9F,the 3rd Building, No.889, Yishan Rd, Xuhui District, Shanghai, China
 Zip code: 200233
 Telephone: +86 (0) 21 6495 1616
 Fax: +86 (0) 21 6495 3679
 Internet: <http://www.cn.sgs.com>

1.2 Details of Applicant

Name: TCL&Alcatel
 Address: C district, 4, Digital technology area, Gaoxin nan rd,
 Shenzhen

1.3 Description of EUT(s)

Brand name	ALCATEL	
Model No.	CVLE6 Crystal	
Market Name	OT-E230a	
Serial No.	IMEI: 01098600000025-5	
Sample Status	Production	
Battery Type	Lithium-Ion	
Antenna Type	Inner Antenna	
Operation Mode	GSM850/PCS1900	
Modulation Mode	GMSK	
Frequency range	GSM850	Tx: 824~849 MHz
		Rx: 869~894 MHz
	PCS1900	Tx: 1850~1910 MHz
		Rx: 1930~1990 MHz
Maximum RF Conducted Power	GSM850: 31.9dBm, PCS1900: 30dBm	

1.4 Test Environment

Ambient temperature: 22.0° C

Tissue Simulating Liquid: 22° C

Relative Humidity: 45%~55%

1.5 Operation Configuration

Configuration 1: GSM 850, LeftHandSide Cheek & 15 ° Tilt Position

Configuration 2: GSM 850, RightHandSide Cheek & 15 ° Tilt Position

Configuration 3: GSM 850, BodyWorn (1.5cm between EUT and phantom)

Configuration 4: GSM 1900, LeftHandSide Cheek & 15 ° Tilt Position

Configuration 5: GSM 1900, RightHandSide Cheek & 15 ° Tilt Position

Configuration 6: GSM 1900, BodyWorn (1.5cm between EUT and phantom)

1.6 The SAR Measurement System

A photograph of the SAR measurement System is given in Fig.a.

This SAR Measurement System uses a Computer-controlled 3-D stepper motor system (Speag Dasy 4 professional system). A Model ET3DV6 1705 E-field probe is used to determine the internal electric fields. The SAR can be obtained from the equation $SAR = \sigma (|E_i|^2) / \rho$ where σ and ρ are the conductivity and mass density of the tissue-simulant.

The DASY4 system for performing compliance tests consists of the following items:

- A standard high precision 6-axis robot (Stabile RX family) with controller, teach pendant and software. An arm extension for accommodation the data acquisition electronics (DAE).
- A dosimetric probe, i.e., an isotropic E-field probe optimized and calibrated for usage in tissue simulating liquid. The probe is equipped with an optical surface detector system.
- A data acquisition electronics (DAE) which performs the signal amplification, signal multiplexing, AD-conversion, offset measurements, mechanical surface detection, collision detection, etc. The unit is battery powered with standard or rechargeable batteries. The signal is optically transmitted to the EOC.

- The Electro-optical converter (EOC) performs the conversion between optical and electrical of the signals for the digital communication to DAE and for the analog signal from the optical surface detection. The EOC is connected to the measurement server.

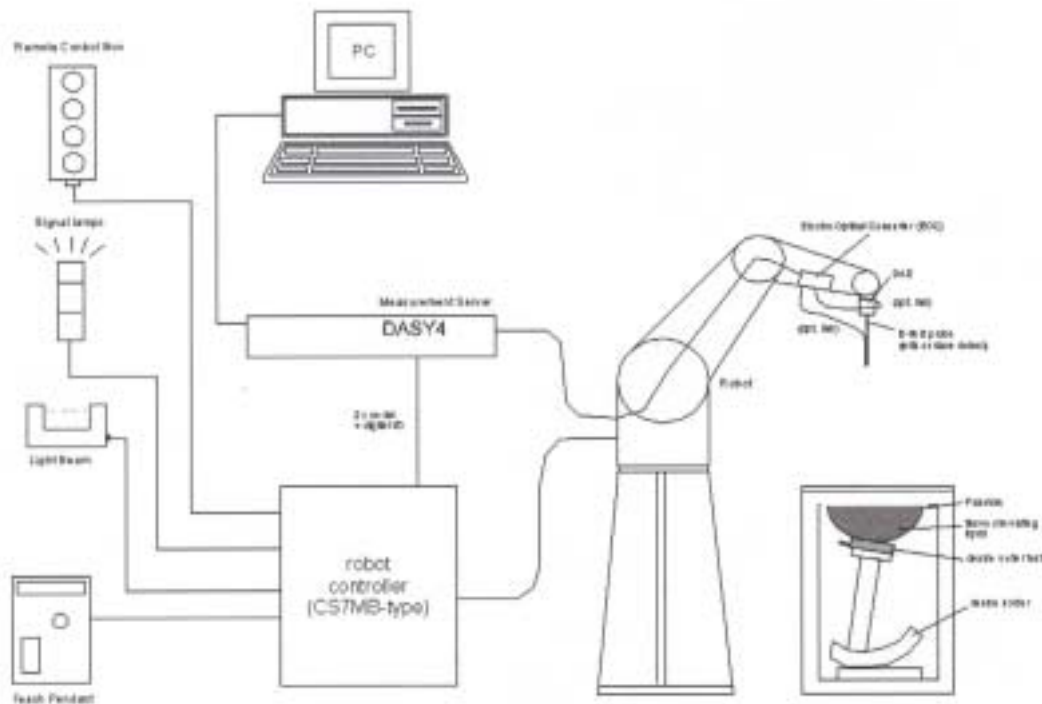

Fig. a SAR System Configuration

- The function of the measurement server is to perform the time critical tasks such as signal filtering, control of the robot operation and fast movement interrupts.
- A probe alignment unit which improves the (absolute) accuracy of the probe positioning.
- A computer operating Windows 2000.
- DASY4 software.
- Remote control with teach pendant and additional circuitry for robot safety such as warning lamps, etc.
- The SAM twin phantom enabling testing left-hand, right-hand and body-worn usage.
- The device holder for handheld mobile phones.
- Tissue simulating liquid mixed according to the given recipes.

- Validation dipole kits allowing validating the proper functioning of the system.

1.7 SAR System Verification

The microwave circuit arrangement for system verification is sketched in Fig. b. The daily system accuracy verification occurs within the flat section of the SAM phantom. A SAR measurement was performed to see if the measured SAR was within +/- 10% from the target SAR values. These tests were done at 900MHz and 1900MHz. The tests were conducted on the same days as the measurement of the DUT. The obtained results from the system accuracy verification are displayed in the table 1 (SAR values are normalized to 1W forward power delivered to the dipole). During the tests, the ambient temperature of the laboratory was in the range 22°C, the relative humidity was in the range 60% and the liquid depth above the ear reference points was above 15 cm in all the cases. It is seen that the system is operating within its specification, as the results are within acceptable tolerance of the reference values.

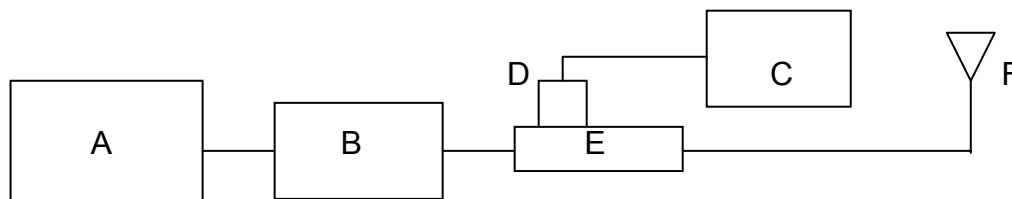

Fig. b the microwave circuit arrangement used for SAR system verification

- A. Agilent Model E4438C Signal Generator
- B. Mini-Circuit Model ZHL-42 Preamplifier
- C. Agilent Model E4416A Power Meter
- D. Agilent Model 8481H Power Sensor
- E. HT CP6100 20N Dual directional coupler
- F. Reference dipole antenna

Validation Kit	Frequency MHz	Target SAR 1g (250mW)	Target SAR 10g (250mW)	Measured SAR 1g	Measured SAR 10g	Measured Date
ET3DV6 SN1705	850 Head	2.6	1.67	2.49	1.59	2006-11-08
ET3DV6 SN1705	850 Head	2.6	1.67	2.51	1.57	2006-11-27
ET3DV6 SN1705	850 Body	2.69	1.74	2.76	1.78	2006-11-13
ET3DV6 SN1705	1900 Head	9.89	5.16	9.68	5.07	2006-11-09
ET3DV6 SN1705	1900 Body	9.81	5.22	9.72	5.17	2006-11-13

Table1. Result System Validation

1.8 Tissue Simulant Fluid for the Frequency Band 850MHz and 1900MHz

The dielectric properties for this body-simulant fluid were measured by using the HP Model 85070D Dielectric Probe (rates frequency band 200 MHz to 20 GHz) in conjunction with Agilent E5071B Network Analyzer (300 KHz-8500 MHz). The Conductivity (σ) and Permittivity (ρ) are listed in Table 2. For the SAR measurement given in this report. The temperature variation of the Tissue Simulant Fluid was 22°C.

Frequency (MHz)	Tissue Type	Limit/Measured	Permittivity (ρ)	Conductivity (σ)	Simulated Tissue Temp (°C)
850	Head	Recommended Limit	41.5±5%	0.90±5%	20-24
		Measured, 2006-11-08	41.94	0.885	22.5
		Measured, 2006-11-27	41.64	0.881	22.4
	Body	Measured, 2006-11-13	54.74	0.941	22.5
		Recommended Limit	55.0±5%	0.97±5%	20-24
1900	Head	Measured, 2006-11-09	38.46	1.468	22.3
		Recommended Limit	40.0±5%	1.40±5%	20-24

	Body	Measured, 2006-11-13	53.51	1.61	22.6
		Recommended Limit	53.3±5%	1.52±5%	20-24

Table 2. Dielectric parameters for the Frequency Band 850MHz&1900MHZ

1.9 Test Standards and Limits

According to FCC 47 CFR §2.1093(d) the limits to be used for evaluation are based generally on criteria published by the American National Standards Institute (ANSI) for localized specific absorption rate (SAR) in Section 4.2 of "IEEE Standard for Safety Levels with Respect to Human Exposure to Radio Frequency Electromagnetic Fields, 3KHz to 300GHz," ANSI/IEEE C95.1-1992, Copyright 1992 by the Institute of Electrical & Electronics Engineers, Inc., New York, New York 10071.

Human Exposure	Uncontrolled Environment General Population
Spatial Peak SAR (Brain)	1.60 mW/g (averaged over a mass of 1g)

Table3. RF Exposure Limits

Notes:

1. Uncontrolled environments are defined as locations where there is potential exposure of individuals who have no knowledge or control of their potential exposure.

2. Summary of Results

Mode	Test Configuration		SAR, Averaged over 1g(W/kg)			Temperature ()	Verdict
	Channel/Power(dBm)		Low/31.9	Middle/31.9	High/31.9		
GSM850	Left	Cheek	1.10	1.05	0.814	22	Pass
		Tilt	0.353	0.224	0.169	22	Pass
	Right	Cheek	1.13	1.09	0.835	22	Pass
		Tilt	0.318	0.259	0.200	22	Pass
	Body	Distance 1.5cm	0.627	0.512	0.397	22	Pass

Mode	Test Configuration		SAR, Averaged over 1g(W/kg)			Temperature ()	Verdict
	Channel/Power(dBm)		Low/30.0	Middle/29.9	High/29.5		
PCS1900	Left	Cheek	0.665	0.710	0.783	22	Pass
		Tilt	0.174	0.181	0.191	22	Pass
	Right	Cheek	0.701	0.732	0.806	22	Pass
		Tilt	0.198	0.201	0.208	22	Pass
	Body	Distance 1.5cm	0.320	0.335	0.382	22	Pass

Maximum Values

Frequency Band(MHz)	EUT position	Conducted Output Power (dBm)	1g Average (W/Kg)	Power Drift (dB)	Amb. Temp ()	Verdict
850	LeftHandSide Cheek, Low Channel	31.9	1.10	-0.211	22	PASS
	RightHandSide Cheek, Low Channel	31.9	1.13	0.227	22	PASS
	BodyWorn, Low Channel	31.9	0.627	-0.176	22	PASS

1900	LeftHandSide Cheek, High Channel	29.5	0.783	-0.094	22	PASS
	RightHandSide Cheek, High Channel	29.5	0.806	-0.205	22	PASS
	BodyWorn, High Channel	29.5	0.382	-0.025	22	PASS

Note:

1. In GSM850 band, the low, middle and high channels are CH128/824.2MHz, CH189/836.4MHz and CH251/848.8MHz separately.
2. In PCS1900 band, the low, middle and high channels are CH512/1805.2MHz, CH661/1880.0MHz and CH810/1909.8MHz separately.
3. For the Bodyworn measurements the sample was only placed with the antenna toward the phantom since this position delivers the highest SAR values.
4. For the Bodyworn measurements, the distance from the sample to the phantom is 1.5 cm.

3. Instruments List

Instrument	Model	Serial number	NO.	Date of last Calibration
Desktop PC	COMPAQ EVO	N/A	GSM-SAR-025	N/A
Dasy 4 software	V 4.6 build 23	N/A	GSM-SAR-001	N/A
Probe	ET3DV6	1705	GSM-SAR-034	2005.12.24
DAE	DAE3	516	GSM-SAR-023	2006.03.08
Phantom	SAM 12	TP-1283	GSM-SAR-005	N/A
Robot	RX90L	F03/5V32A1/A01	GSM-SAR-008	N/A
Dielectric probe kit	85070D	US01440168	GSM-SAR-016	2005.12.19
Agilent network analyzer	E5071B	MY42100549	GSM-SAR-007	2005.12.19
Agilent signal generator	E4438	14438CATO-19719	GSM-SAR-008	2005.12.19

Mini-Circuits preamplifier	ZHL-42	D041905	GSM-SAR-033	2006.04.19
Agilent power meter	E4416A	GB41292095	GSM-SAR-010	2005.12.19
Agilent power sensor	8481H	MY41091234	GSM-SAR-011	2005.12.19
HT CP6100 20N Coupling	6100	SCP301480120	GSM-SAR-012	2005.12.19
R&S Universal radio communication tester	CMU200	103633	GSM-AUD-002	2005.12.20

4. Measurements

4.1 LeftHandSide-Cheek-GSM850-Low

Date/Time: 2006-11-27 17:05:07

Test Laboratory: SGS-GSM

GSM850-LeftHandSide-Cheek-Low

DUT: GSM10142308D; Type: Head; Serial: 01098600000025-5

Communication System: GSM850-GSM Mode; Frequency: 824.2 MHz; Duty Cycle: 1:8.3

Medium: HSL850-Head Medium parameters used: $f = 824.2$ MHz; $\sigma = 0.872$ mho/m; $r = 41.9$; $\rho = 1000$ kg/m³

Phantom section: Left Section

DASY4 Configuration:

- Probe: ET3DV6 - SN1705; ConvF(5.98, 5.98, 5.98); Calibrated: 2005-12-24
- Sensor-Surface: 4mm (Mechanical Surface Detection)
- Electronics: DAE3 Sn516; Calibrated: 2006-3-8
- Phantom: SAM 12; Type: SAM V4.0; Serial: TP-1283
- Measurement SW: DASY4, V4.7 Build 44; Postprocessing SW: SEMCAD, V1.8 Build 171

Cheek position - Low(Renew)/Area Scan (61x101x1): Measurement grid: dx=15mm, dy=15mm

Maximum value of SAR (interpolated) = 1.20 mW/g

Cheek position - Low(Renew)/Zoom Scan (7x7x7)/Cube 0: Measurement grid: dx=5mm, dy=5mm, dz=5mm

Reference Value = 6.47 V/m; Power Drift = -0.211 dB

Peak SAR (extrapolated) = 1.26 W/kg

SAR(1 g) = 1.1 mW/g; SAR(10 g) = 0.732 mW/g
Maximum value of SAR (measured) = 1.19 mW/g

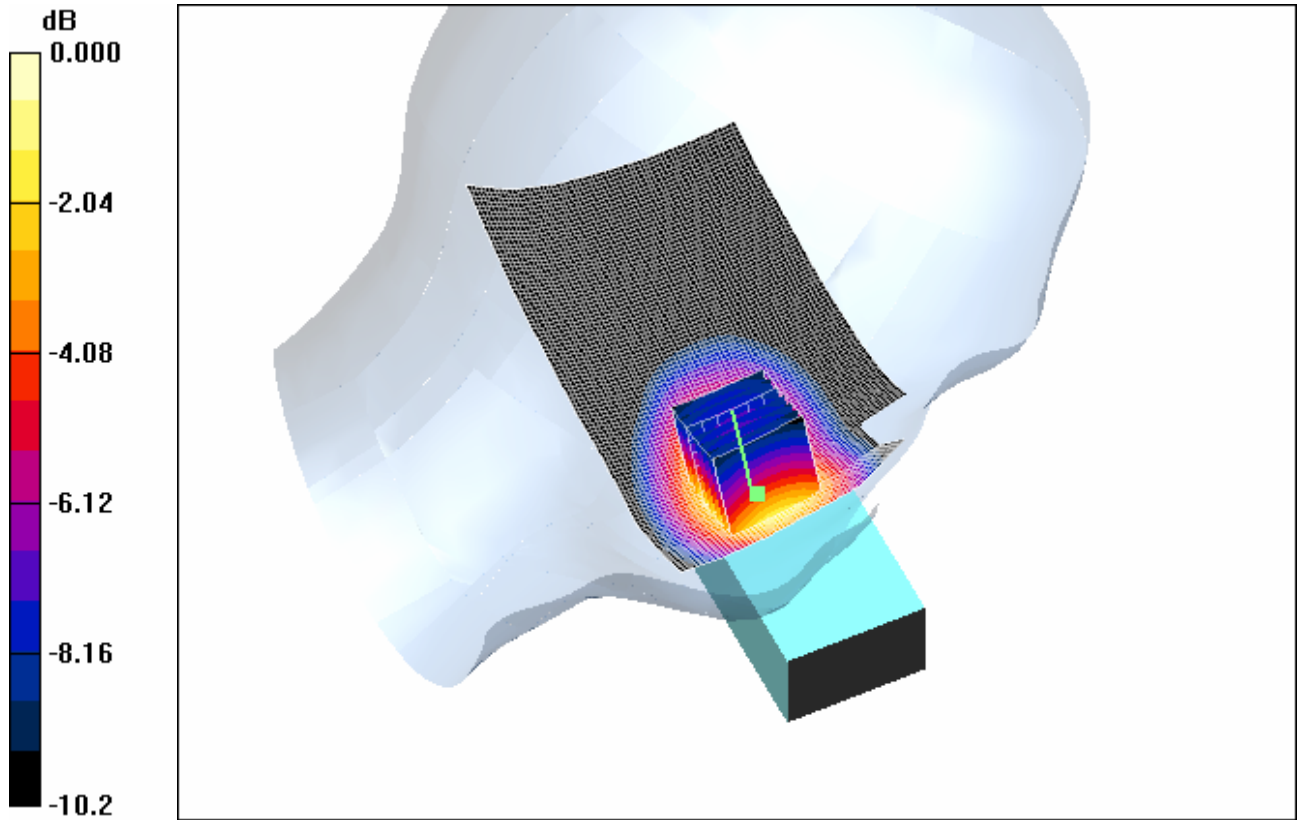

0 dB = 1.19mW/g

4.2 LeftHandSide-Cheek-GSM850-Middle

Date/Time: 2006-11-9 8:50:11

Test Laboratory: SGS-GSM

GSM850-LeftHandSide-Cheek-Middle

DUT: GSM10142308D; Type: Head; Serial: 0109860000025-5

Communication System: GSM850-GSM Mode; Frequency: 836.4 MHz; Duty Cycle: 1:8.3

Medium: HSL850-Head Medium parameters used: $f = 836.4$ MHz; $\sigma = 0.886$ mho/m; $r = 41.9$; $\epsilon =$

1000 kg/m³

Phantom section: Left Section

DASY4 Configuration:

- Probe: ET3DV6 - SN1705; ConvF(5.98, 5.98, 5.98); Calibrated: 2005-12-24
- Sensor-Surface: 4mm (Mechanical Surface Detection)
- Electronics: DAE3 Sn516; Calibrated: 2006-3-8
- Phantom: SAM 12; Type: SAM V4.0; Serial: TP-1283
- Measurement SW: DASY4, V4.7 Build 44; Postprocessing SW: SEMCAD, V1.8 Build 171

Cheek position - Mid/Area Scan (61x101x1): Measurement grid: dx=15mm, dy=15mm

Maximum value of SAR (interpolated) = 1.16 mW/g

Cheek position - Mid/Zoom Scan (7x7x7) (7x7x7)/Cube 0: Measurement grid: dx=5mm, dy=5mm, dz=5mm

Reference Value = 6.89 V/m; Power Drift = -0.173 dB

Peak SAR (extrapolated) = 1.55 W/kg

SAR(1 g) = 1.05 mW/g; SAR(10 g) = 0.685 mW/g

Maximum value of SAR (measured) = 1.15 mW/g

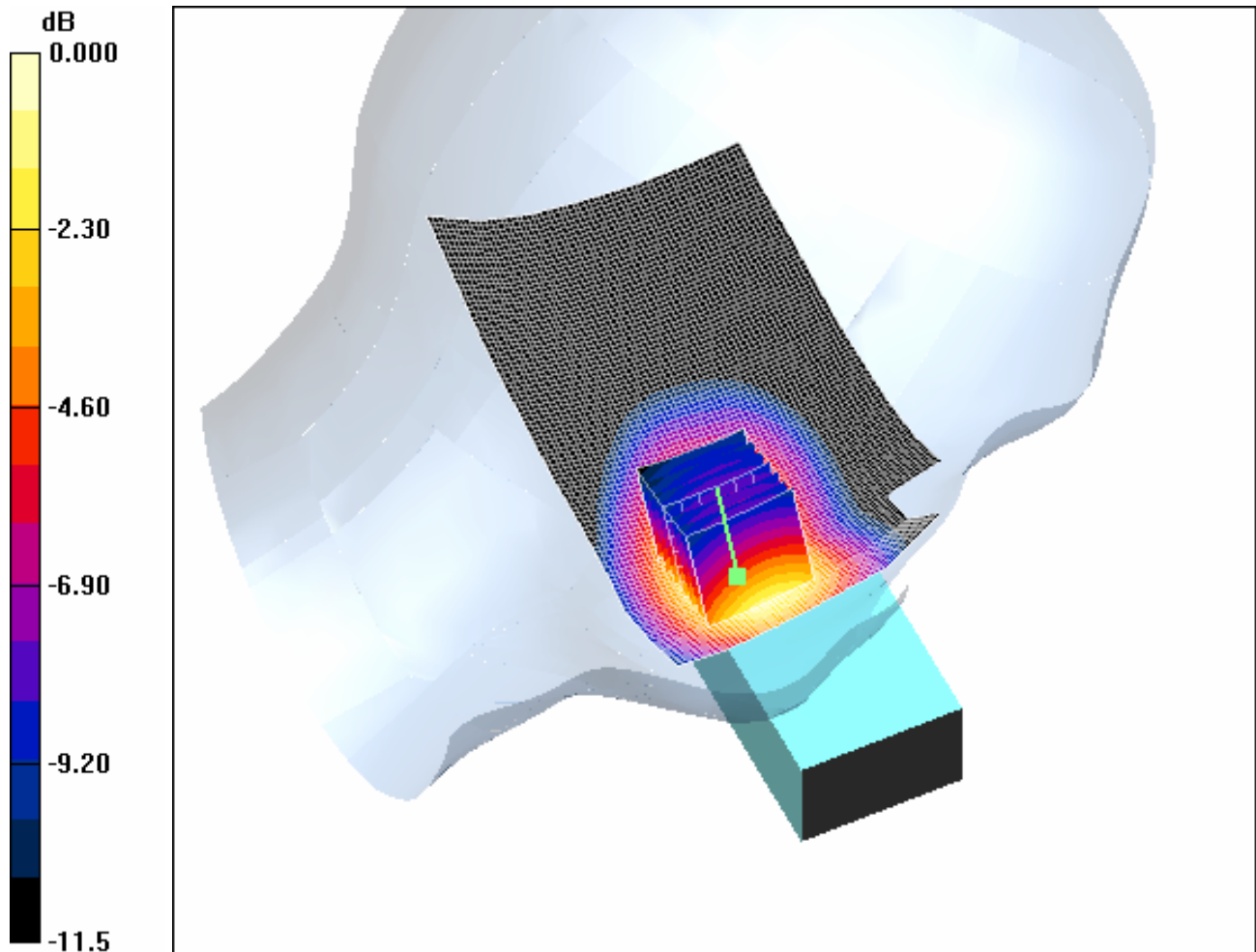

0 dB = 1.15mW/g

4.3 LeftHandSide-Cheek-GSM850-High

Date/Time: 2006-11-9 9:55:01

Test Laboratory: SGS-GSM

GSM850-LeftHandSide-Cheek-High

DUT: GSM10142308D; Type: Head; Serial: 0109860000025-5

Communication System: GSM850-GSM Mode; Frequency: 848.8 MHz; Duty Cycle: 1:8.3

Medium: HSL850-Head Medium parameters used: $f = 848.8$ MHz; $\sigma = 0.9$ mho/m; $r = 42$; $\rho = 1000$

kg/m³

Phantom section: Left Section

DASY4 Configuration:

- Probe: ET3DV6 - SN1705; ConvF(5.98, 5.98, 5.98); Calibrated: 2005-12-24
- Sensor-Surface: 4mm (Mechanical Surface Detection)
- Electronics: DAE3 Sn516; Calibrated: 2006-3-8
- Phantom: SAM 12; Type: SAM V4.0; Serial: TP-1283
- Measurement SW: DASY4, V4.7 Build 44; Postprocessing SW: SEMCAD, V1.8 Build 171

Cheek position - High/Area Scan (61x101x1): Measurement grid: dx=15mm, dy=15mm

Maximum value of SAR (interpolated) = 0.877 mW/g

Cheek position - High/Zoom Scan (7x7x7) (7x7x7)/Cube 0: Measurement grid: dx=5mm, dy=5mm, dz=5mm

Reference Value = 5.91 V/m; Power Drift = 0.029 dB

Peak SAR (extrapolated) = 1.19 W/kg

SAR(1 g) = 0.814 mW/g; SAR(10 g) = 0.528 mW/g

Maximum value of SAR (measured) = 0.895 mW/g

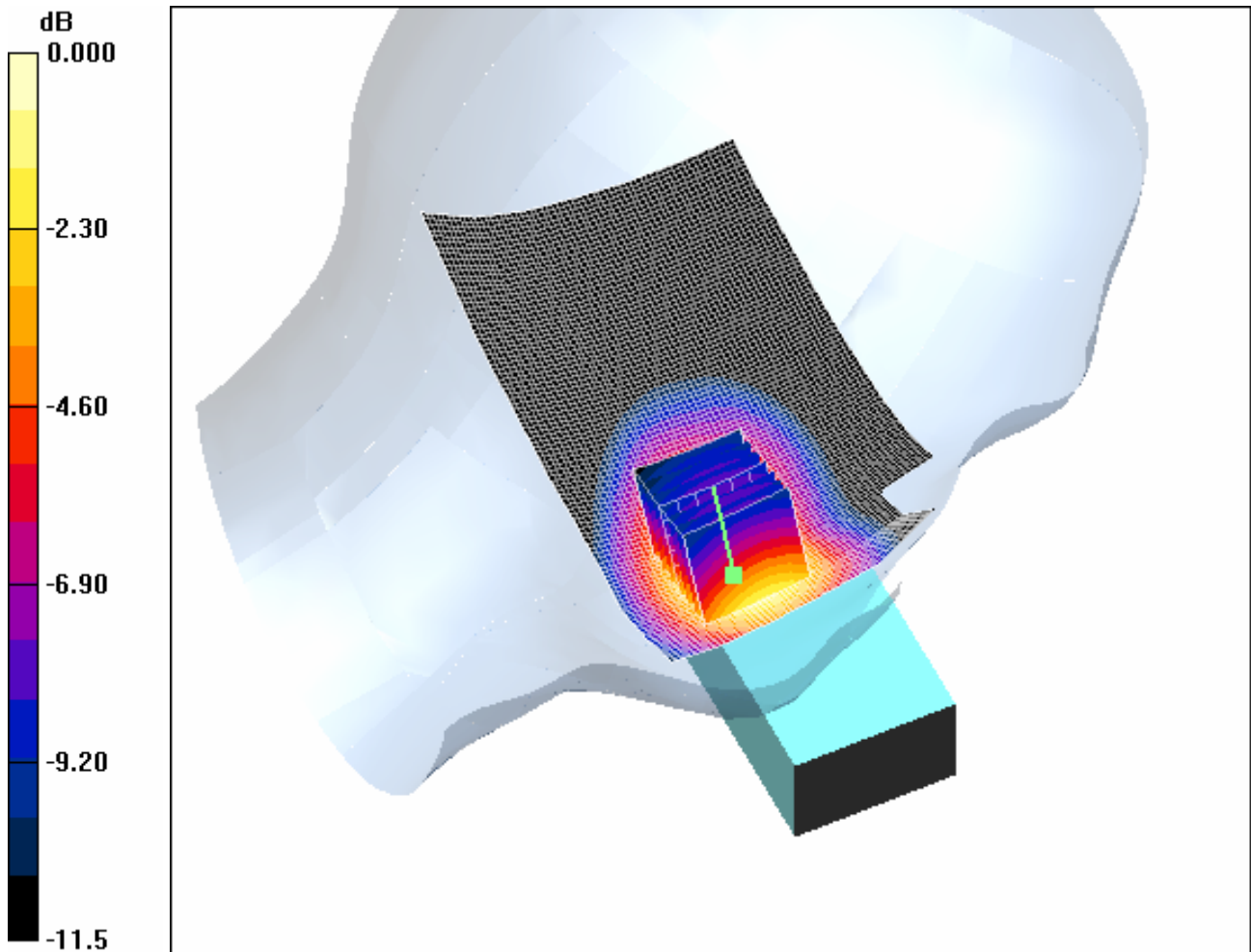

0 dB = 0.895mW/g

4.4 LeftHandSide-Tilt-GSM850-Low

Date/Time: 2006-11-9 11:35:09

Test Laboratory: SGS-GSM

GSM850-LeftHandSide-Tilt-Low

DUT: GSM10142308D; Type: Head; Serial: 0109860000025-5

Communication System: GSM850-GSM Mode; Frequency: 824.2 MHz; Duty Cycle: 1:8.3

Medium: HSL850-Head Medium parameters used: $f = 824.2$ MHz; $\sigma = 0.872$ mho/m; $r = 41.9$; $\epsilon =$

1000 kg/m³

Phantom section: Left Section

DASY4 Configuration:

- Probe: ET3DV6 - SN1705; ConvF(5.98, 5.98, 5.98); Calibrated: 2005-12-24
- Sensor-Surface: 4mm (Mechanical Surface Detection)
- Electronics: DAE3 Sn516; Calibrated: 2006-3-8
- Phantom: SAM 12; Type: SAM V4.0; Serial: TP-1283
- Measurement SW: DASY4, V4.7 Build 44; Postprocessing SW: SEMCAD, V1.8 Build 171

Tilt position - Low 2/Area Scan (61x101x1): Measurement grid: dx=15mm, dy=15mm

Maximum value of SAR (interpolated) = 0.377 mW/g

Tilt position - Low 2/Zoom Scan (7x7x7)/Cube 0: Measurement grid: dx=5mm, dy=5mm, dz=5mm

Reference Value = 11.0 V/m; Power Drift = -0.074 dB

Peak SAR (extrapolated) = 0.461 W/kg

SAR(1 g) = 0.353 mW/g; SAR(10 g) = 0.259 mW/g

Maximum value of SAR (measured) = 0.378 mW/g

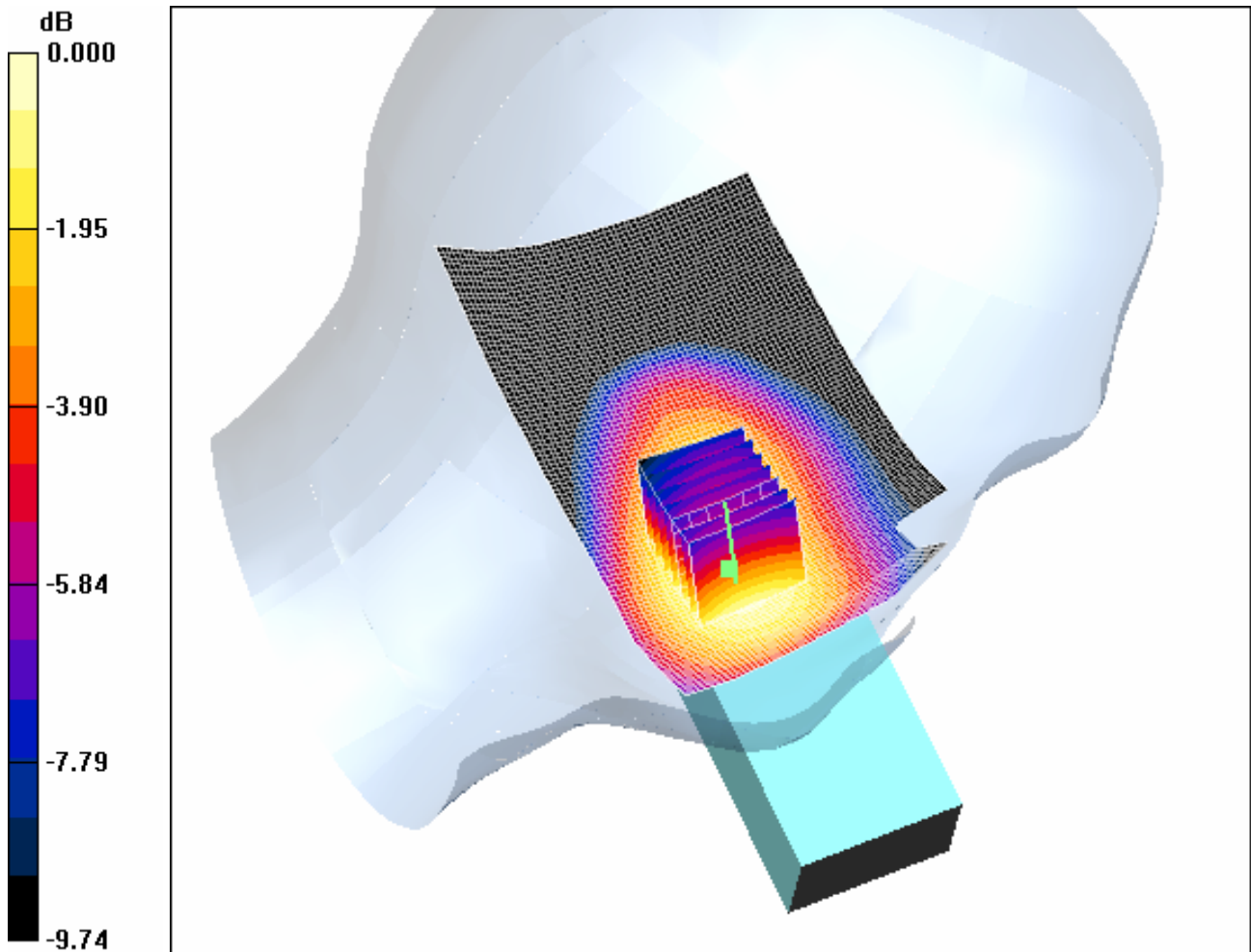

0 dB = 0.378mW/g

4.5 LeftHandSide-Tilt-GSM850-Middle

Date/Time: 2006-11-9 10:47:43

Test Laboratory: SGS-GSM

GSM850-LeftHandSide-Tilt-Middle

DUT: GSM10142308D; Type: Head; Serial: 0109860000025-5

Communication System: GSM850-GSM Mode; Frequency: 836.4 MHz; Duty Cycle: 1:8.3

Medium: HSL850-Head Medium parameters used: $f = 836.4$ MHz; $\sigma = 0.886$ mho/m; $r = 41.9$; $\epsilon =$

1000 kg/m³

Phantom section: Left Section

DASY4 Configuration:

- Probe: ET3DV6 - SN1705; ConvF(5.98, 5.98, 5.98); Calibrated: 2005-12-24
- Sensor-Surface: 4mm (Mechanical Surface Detection)
- Electronics: DAE3 Sn516; Calibrated: 2006-3-8
- Phantom: SAM 12; Type: SAM V4.0; Serial: TP-1283
- Measurement SW: DASY4, V4.7 Build 44; Postprocessing SW: SEMCAD, V1.8 Build 171

Tilt position - Mid 2/Area Scan (61x101x1): Measurement grid: dx=15mm, dy=15mm

Maximum value of SAR (interpolated) = 0.236 mW/g

Tilt position - Mid 2/Zoom Scan (7x7x7) (7x7x7)/Cube 0: Measurement grid: dx=5mm, dy=5mm, dz=5mm

Reference Value = 8.32 V/m; Power Drift = -0.071 dB

Peak SAR (extrapolated) = 0.289 W/kg

SAR(1 g) = 0.224 mW/g; SAR(10 g) = 0.166 mW/g

Maximum value of SAR (measured) = 0.238 mW/g

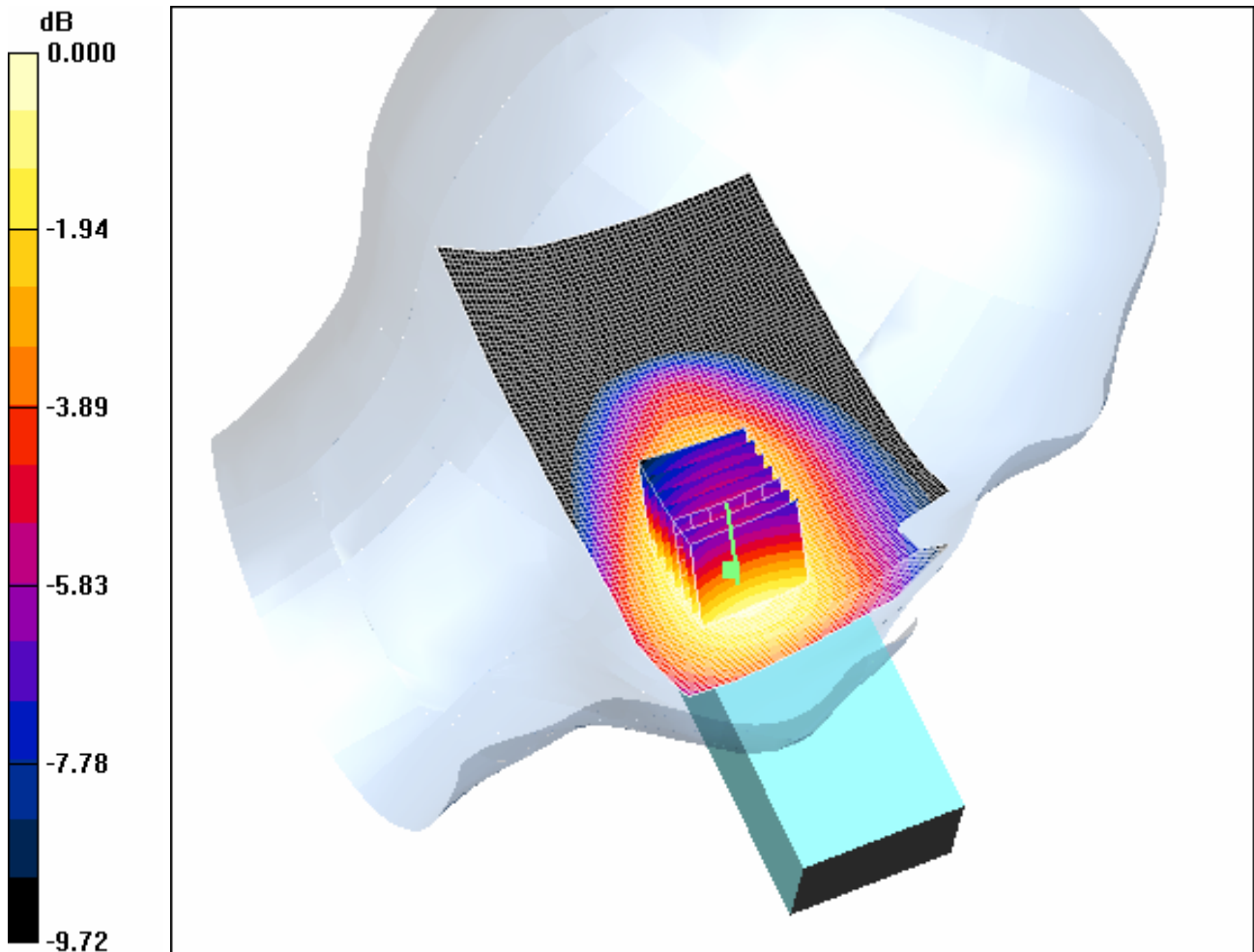

0 dB = 0.238mW/g

4.6 LeftHandSide-Tilt-GSM850-High

Date/Time: 2006-11-9 10:21:17

Test Laboratory: SGS-GSM

GSM850-LeftHandSide-Tilt-High

DUT: GSM10142308D; Type: Head; Serial: 01098600000025-5

Communication System: GSM850-GSM Mode; Frequency: 848.8 MHz; Duty Cycle: 1:8.3

Medium: HSL850-Head Medium parameters used: $f = 848.8$ MHz; $\sigma = 0.9$ mho/m; $r = 42$; $\epsilon = 1000$

kg/m³

Phantom section: Left Section

DASY4 Configuration:

- Probe: ET3DV6 - SN1705; ConvF(5.98, 5.98, 5.98); Calibrated: 2005-12-24
- Sensor-Surface: 4mm (Mechanical Surface Detection)
- Electronics: DAE3 Sn516; Calibrated: 2006-3-8
- Phantom: SAM 12; Type: SAM V4.0; Serial: TP-1283
- Measurement SW: DASY4, V4.7 Build 44; Postprocessing SW: SEMCAD, V1.8 Build 171

Tilt position - High 2/Area Scan (61x101x1): Measurement grid: dx=15mm, dy=15mm

Maximum value of SAR (interpolated) = 0.179 mW/g

Tilt position - High 2/Zoom Scan (7x7x7) (7x7x7)/Cube 0: Measurement grid: dx=5mm, dy=5mm, dz=5mm

Reference Value = 7.10 V/m; Power Drift = -0.059 dB

Peak SAR (extrapolated) = 0.215 W/kg

SAR(1 g) = 0.169 mW/g; SAR(10 g) = 0.126 mW/g

Maximum value of SAR (measured) = 0.180 mW/g

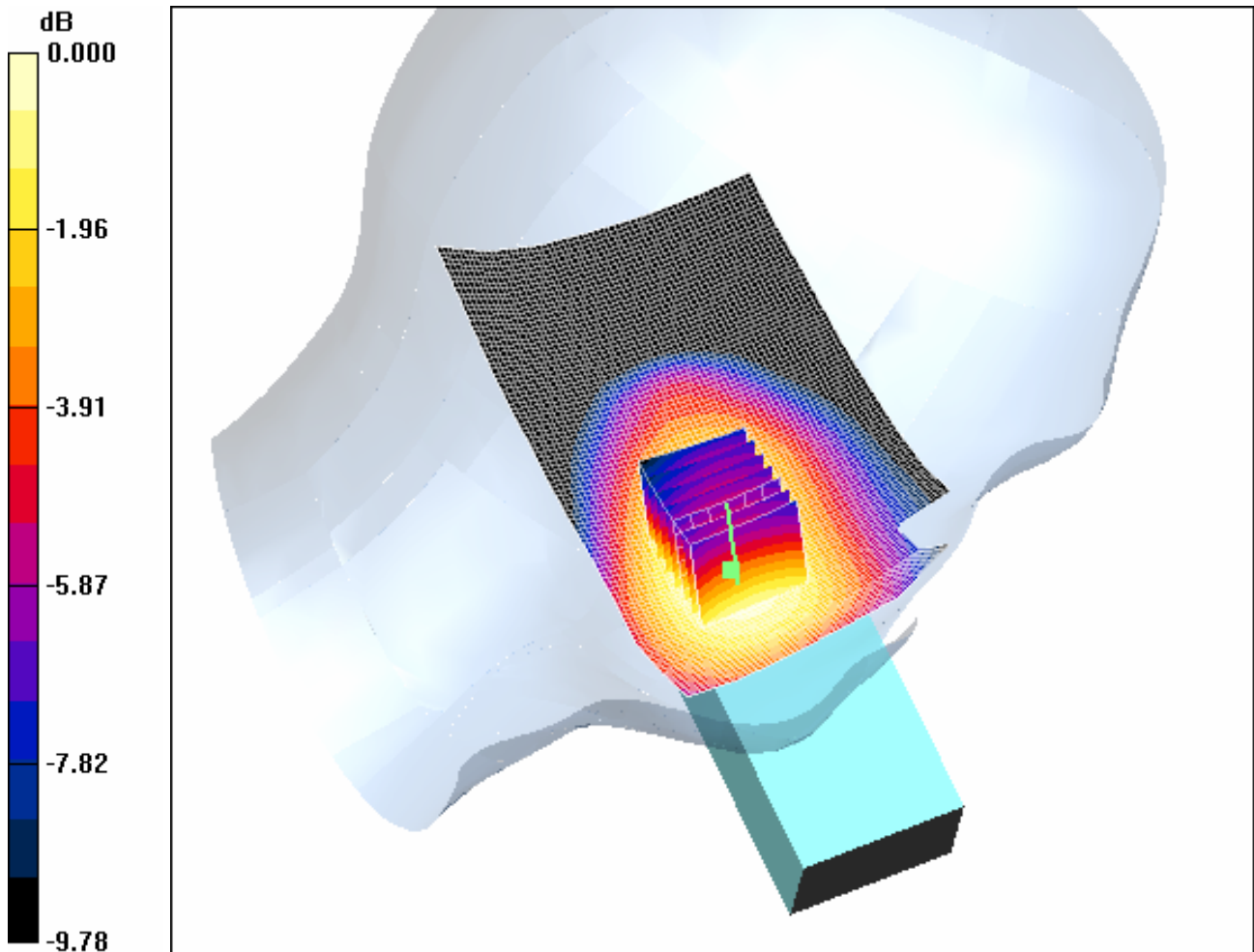

0 dB = 0.180mW/g

4.7 RightHandSide-Cheek-GSM850-Low

Date/Time: 2006-11-27 15:59:23

Test Laboratory: SGS-GSM

GSM850-RightHandSide-Cheek-Low

DUT: GSM10142308D; Type: Head; Serial: 0109860000025-5

Communication System: GSM850-GSM Mode; Frequency: 824.2 MHz; Duty Cycle: 1:8.3

Medium: HSL850-Head Medium parameters used: $f = 824.2$ MHz; $\epsilon = 0.872$ mho/m; $r = 41.9$; $\sigma =$

1000 kg/m³

Phantom section: Right Section

DASY4 Configuration:

- Probe: ET3DV6 - SN1705; ConvF(5.98, 5.98, 5.98); Calibrated: 2005-12-24
- Sensor-Surface: 4mm (Mechanical Surface Detection)
- Electronics: DAE3 Sn516; Calibrated: 2006-3-8
- Phantom: SAM 12; Type: SAM V4.0; Serial: TP-1283
- Measurement SW: DASY4, V4.7 Build 44; Postprocessing SW: SEMCAD, V1.8 Build 171

Cheek position - Low(Retest) 2/Area Scan (61x101x1): Measurement grid: dx=15mm, dy=15mm

Maximum value of SAR (interpolated) = 1.31 mW/g

Cheek position - Low(Retest) 2/Zoom Scan (7x7x7) (7x7x7)/Cube 0: Measurement grid:

dx=5mm, dy=5mm, dz=5mm

Reference Value = 6.05 V/m; Power Drift = 0.227 dB

Peak SAR (extrapolated) = 1.30 W/kg

SAR(1 g) = 1.13 mW/g; SAR(10 g) = 0.760 mW/g

Maximum value of SAR (measured) = 1.22 mW/g

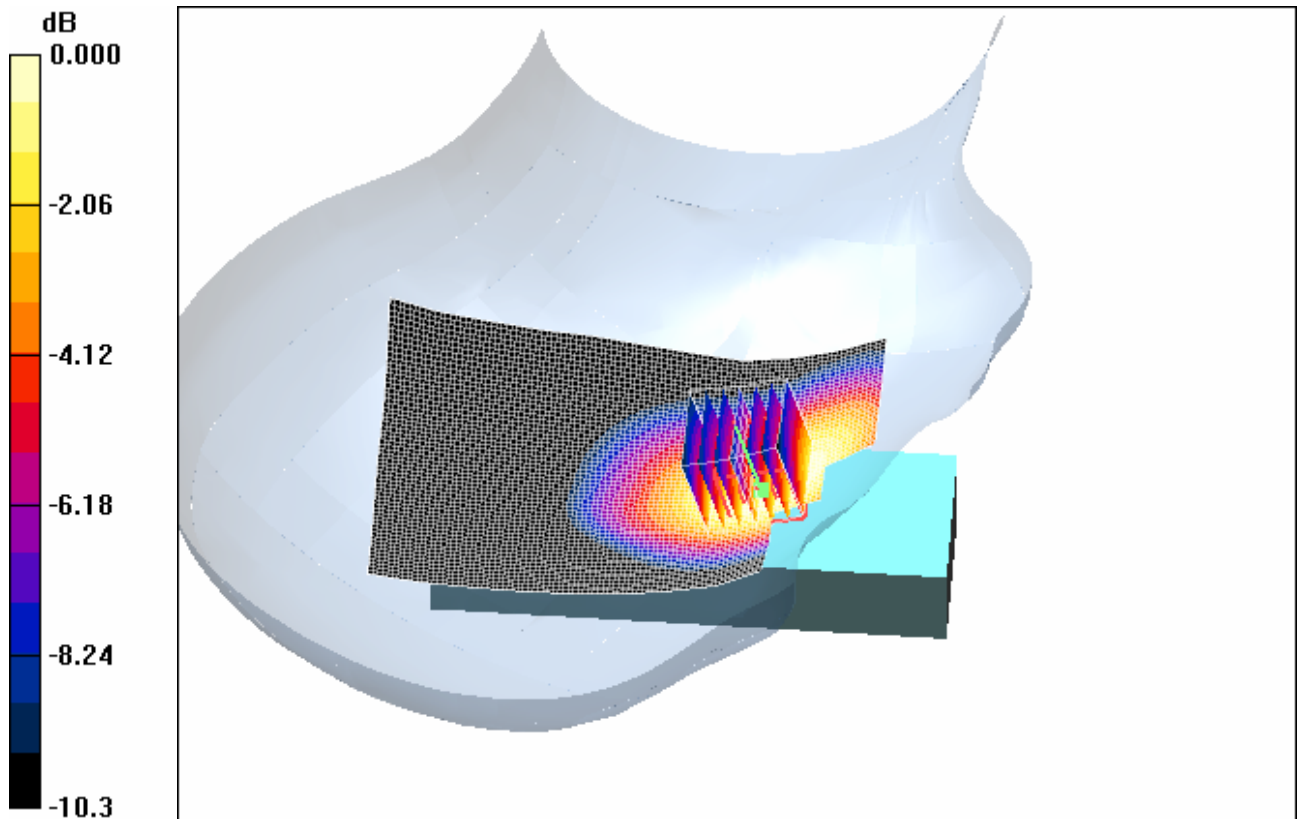

0 dB = 1.22mW/g

4.8 RightHandSide-Cheek-GSM850-Middle

Date/Time: 2006-11-8 14:18:57

Test Laboratory: SGS-GSM

GSM850-RightHandSide-Cheek-Middle

DUT: GSM10142308D; Type: Head; Serial: 0109860000025-5

Communication System: GSM850-GSM Mode; Frequency: 836.4 MHz; Duty Cycle: 1:8.3

Medium: HSL850-Head Medium parameters used: $f = 836.4$ MHz; $\sigma = 0.886$ mho/m; $\epsilon_r = 41.9$; $\rho = 1000$ kg/m³

Phantom section: Right Section

DASY4 Configuration:

- Probe: ET3DV6 - SN1705; ConvF(5.98, 5.98, 5.98); Calibrated: 2005-12-24
- Sensor-Surface: 4mm (Mechanical Surface Detection)
- Electronics: DAE3 Sn516; Calibrated: 2006-3-8
- Phantom: SAM 12; Type: SAM V4.0; Serial: TP-1283
- Measurement SW: DASY4, V4.7 Build 44; Postprocessing SW: SEMCAD, V1.8 Build 171

Cheek position - Middle/Area Scan (61x101x1): Measurement grid: dx=15mm, dy=15mm

Maximum value of SAR (interpolated) = 1.19 mW/g

Cheek position - Middle/Zoom Scan (7x7x7)/Cube 0: Measurement grid: dx=5mm, dy=5mm, dz=5mm

Reference Value = 6.81 V/m; Power Drift = 0.015 dB

Peak SAR (extrapolated) = 1.54 W/kg

SAR(1 g) = 1.09 mW/g; SAR(10 g) = 0.717 mW/g

Maximum value of SAR (measured) = 1.18 mW/g

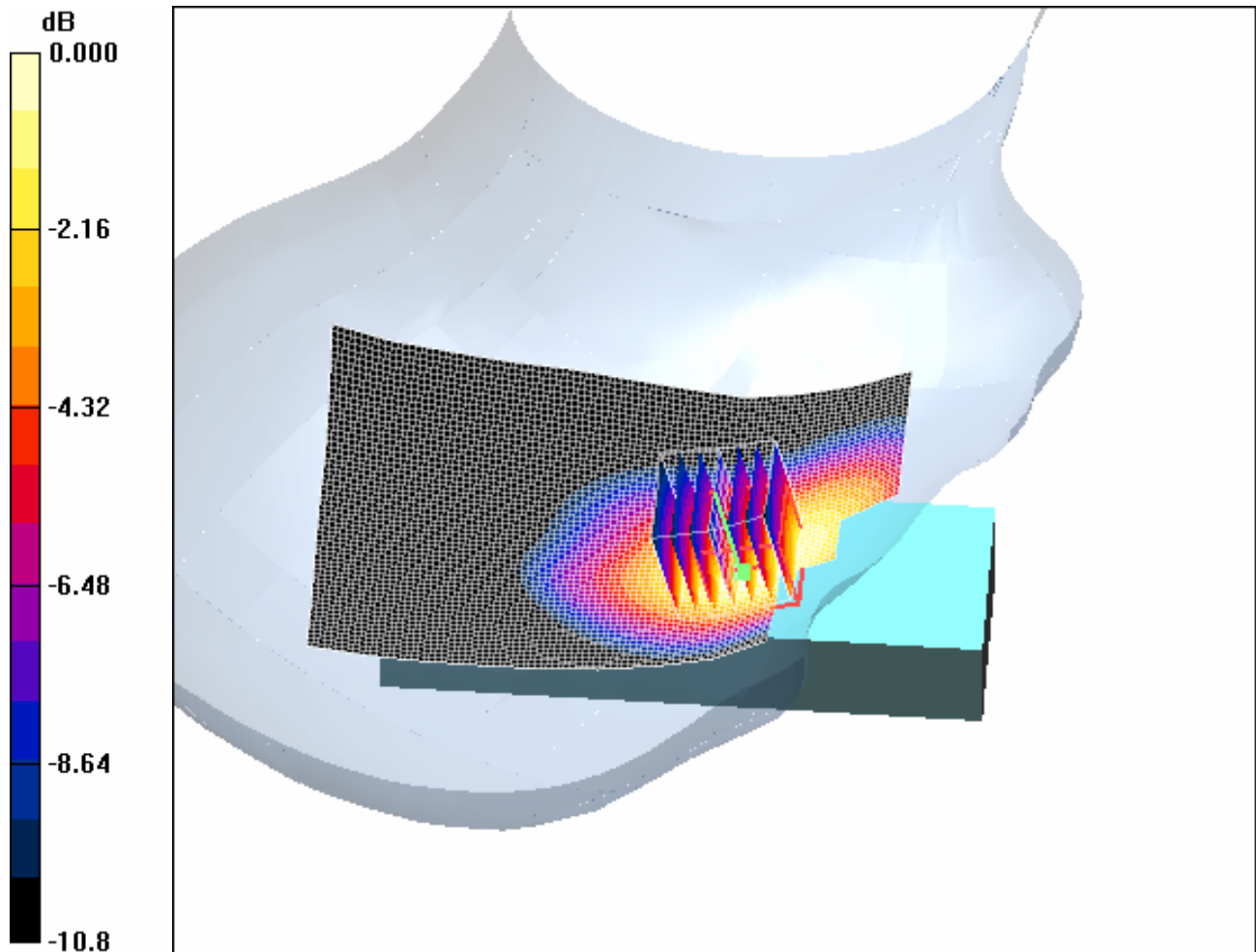

0 dB = 1.18mW/g

4.9 RightHandSide-Cheek-GSM850-High

Date/Time: 2006-11-8 14:44:02

Test Laboratory: SGS-GSM

GSM850-RightHandSide-Cheek-High

DUT: GSM10142308D; Type: Head; Serial: 0109860000025-5

Communication System: GSM850-GSM Mode; Frequency: 848.8 MHz; Duty Cycle: 1:8.3

Medium: HSL850-Head Medium parameters used: $f = 848.8$ MHz; $\sigma = 0.9$ mho/m; $r = 42$; $\epsilon = 1000$

kg/m³

Phantom section: Right Section

DASY4 Configuration:

- Probe: ET3DV6 - SN1705; ConvF(5.98, 5.98, 5.98); Calibrated: 2005-12-24
- Sensor-Surface: 4mm (Mechanical Surface Detection)
- Electronics: DAE3 Sn516; Calibrated: 2006-3-8
- Phantom: SAM 12; Type: SAM V4.0; Serial: TP-1283
- Measurement SW: DASY4, V4.7 Build 44; Postprocessing SW: SEMCAD, V1.8 Build 171

Cheek position - High/Area Scan (61x101x1): Measurement grid: dx=15mm, dy=15mm

Maximum value of SAR (interpolated) = 0.912 mW/g

Cheek position - High/Zoom Scan (7x7x7) (7x7x7)/Cube 0: Measurement grid: dx=5mm, dy=5mm, dz=5mm

Reference Value = 5.93 V/m; Power Drift = 0.057 dB

Peak SAR (extrapolated) = 1.19 W/kg

SAR(1 g) = 0.835 mW/g; SAR(10 g) = 0.550 mW/g

Maximum value of SAR (measured) = 0.908 mW/g

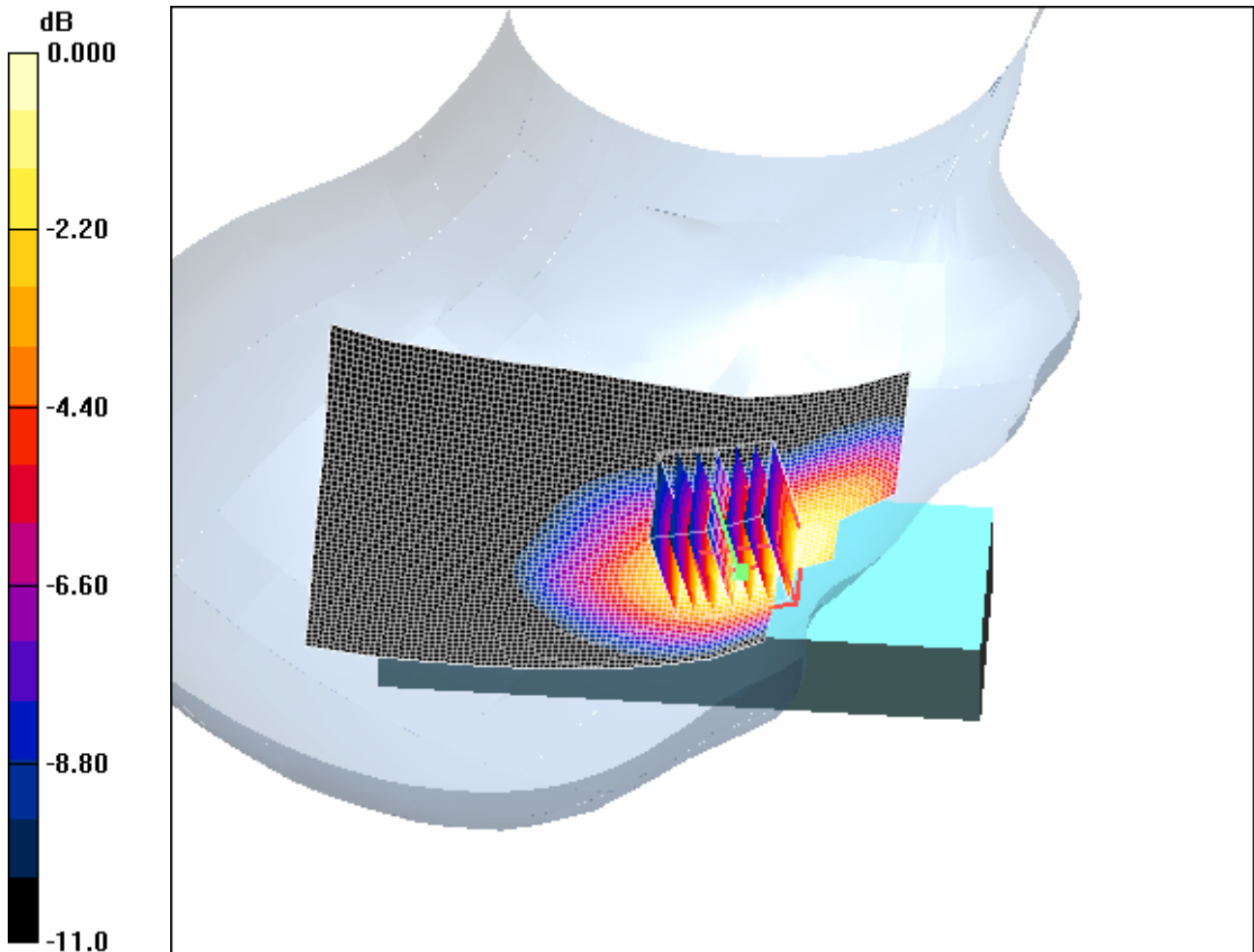

0 dB = 0.908mW/g

4.10 RightHandSide-Tilt-GSM850-Low

Date/Time: 2006-11-8 15:55:00

Test Laboratory: SGS-GSM

GSM850-RightHandSide-Tilt-Low

DUT: GSM10142308D; Type: Head; Serial: 0109860000025-5

Communication System: GSM850-GSM Mode; Frequency: 824.2 MHz; Duty Cycle: 1:8.3

Medium: HSL850-Head Medium parameters used: $f = 824.2$ MHz; $\sigma = 0.872$ mho/m; $r = 41.9$; $\epsilon =$

1000 kg/m³

Phantom section: Right Section

DASY4 Configuration:

- Probe: ET3DV6 - SN1705; ConvF(5.98, 5.98, 5.98); Calibrated: 2005-12-24
- Sensor-Surface: 4mm (Mechanical Surface Detection)
- Electronics: DAE3 Sn516; Calibrated: 2006-3-8
- Phantom: SAM 12; Type: SAM V4.0; Serial: TP-1283
- Measurement SW: DASY4, V4.7 Build 44; Postprocessing SW: SEMCAD, V1.8 Build 171

Tilt position - Low/Area Scan (61x101x1): Measurement grid: dx=15mm, dy=15mm

Maximum value of SAR (interpolated) = 0.347 mW/g

Tilt position - Low/Zoom Scan (7x7x7)/Cube 0: Measurement grid: dx=5mm, dy=5mm, dz=5mm

Reference Value = 11.1 V/m; Power Drift = -0.142 dB

Peak SAR (extrapolated) = 0.412 W/kg

SAR(1 g) = 0.318 mW/g; SAR(10 g) = 0.234 mW/g

Maximum value of SAR (measured) = 0.337 mW/g

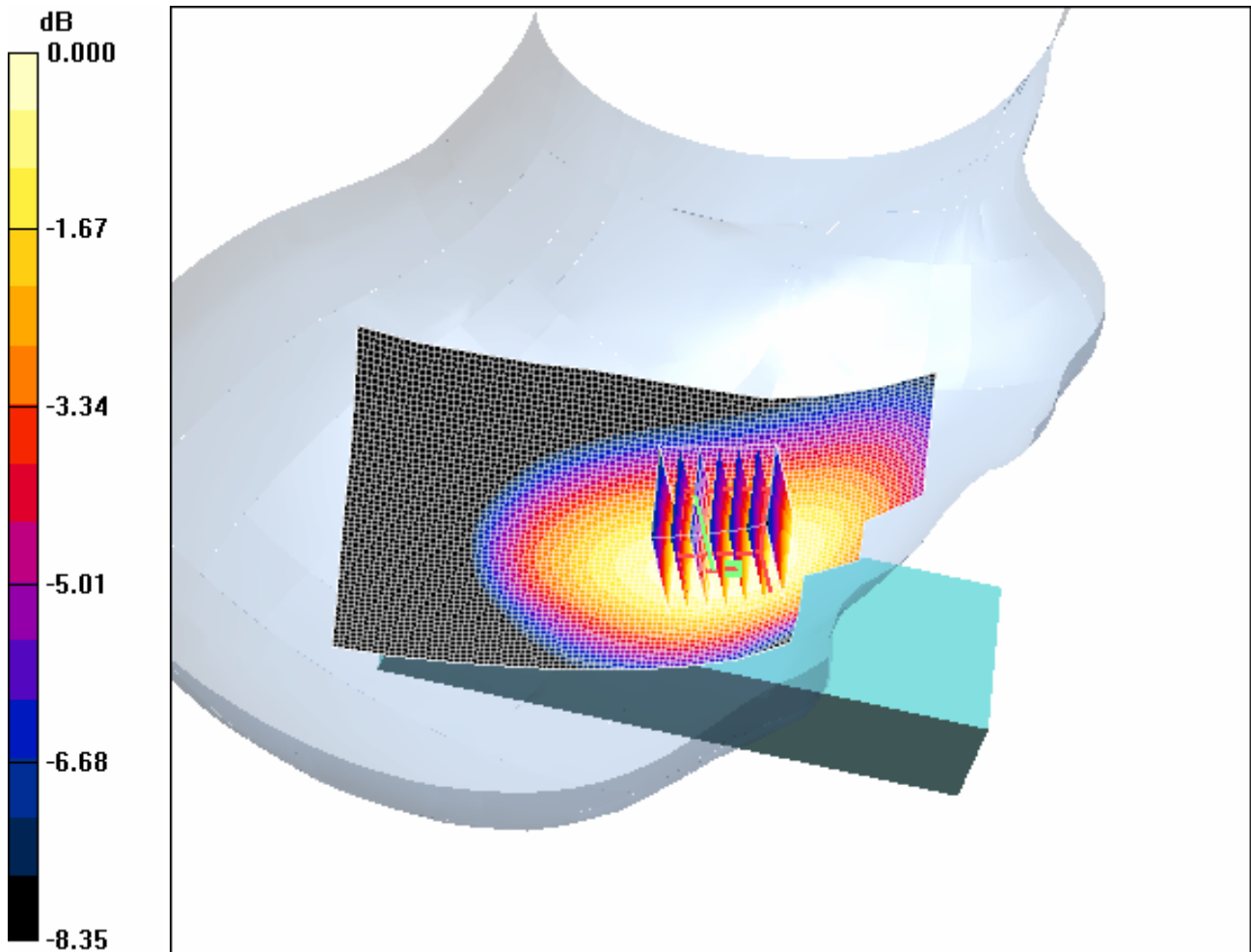

0 dB = 0.337mW/g

4.11 RightHandSide-Tilt-GSM850-Middle

Date/Time: 2006-11-8 15:14:06

Test Laboratory: SGS-GSM

GSM850-RightHandSide-Tilt-Middle

DUT: GSM10142308D; Type: Head; Serial: 0109860000025-5

Communication System: GSM850-GSM Mode; Frequency: 836.4 MHz; Duty Cycle: 1:8.3

Medium: HSL850-Head Medium parameters used: $f = 836.4$ MHz; $\sigma = 0.886$ mho/m; $r = 41.9$; $\epsilon =$

1000 kg/m³

Phantom section: Right Section

DASY4 Configuration:

- Probe: ET3DV6 - SN1705; ConvF(5.98, 5.98, 5.98); Calibrated: 2005-12-24
- Sensor-Surface: 4mm (Mechanical Surface Detection)
- Electronics: DAE3 Sn516; Calibrated: 2006-3-8
- Phantom: SAM 12; Type: SAM V4.0; Serial: TP-1283
- Measurement SW: DASY4, V4.7 Build 44; Postprocessing SW: SEMCAD, V1.8 Build 171

Tilt position - Middle/Area Scan (61x101x1): Measurement grid: dx=15mm, dy=15mm

Maximum value of SAR (interpolated) = 0.281 mW/g

Tilt position - Middle/Zoom Scan (7x7x7)/Cube 0: Measurement grid: dx=5mm, dy=5mm, dz=5mm

Reference Value = 8.91 V/m; Power Drift = -0.024 dB

Peak SAR (extrapolated) = 0.334 W/kg

SAR(1 g) = 0.259 mW/g; SAR(10 g) = 0.190 mW/g

Maximum value of SAR (measured) = 0.273 mW/g

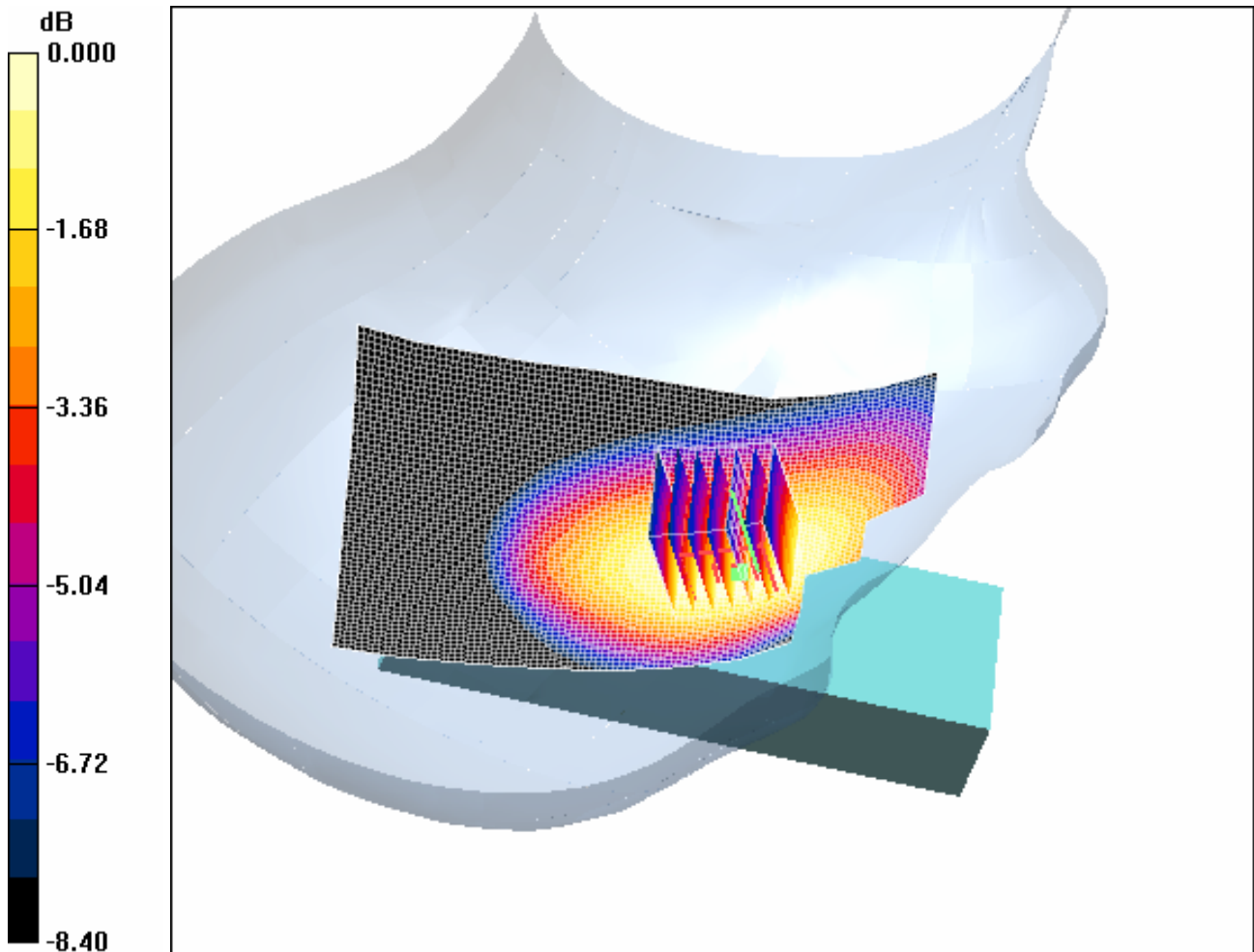

0 dB = 0.273mW/g

4.12 RightHandSide-Tilt-GSM850-High

Date/Time: 2006-11-8 16:19:26

Test Laboratory: SGS-GSM

GSM850-RightHandSide-Tilt-High

DUT: GSM10142308D; Type: Head; Serial: 0109860000025-5

Communication System: GSM850-GSM Mode; Frequency: 848.8 MHz; Duty Cycle: 1:8.3

Medium: HSL850-Head Medium parameters used: $f = 848.8$ MHz; $\epsilon = 0.9$ mho/m; $r = 42$; $\tau = 1000$

kg/m³

Phantom section: Right Section

DASY4 Configuration:

- Probe: ET3DV6 - SN1705; ConvF(5.98, 5.98, 5.98); Calibrated: 2005-12-24
- Sensor-Surface: 4mm (Mechanical Surface Detection)
- Electronics: DAE3 Sn516; Calibrated: 2006-3-8
- Phantom: SAM 12; Type: SAM V4.0; Serial: TP-1283
- Measurement SW: DASY4, V4.7 Build 44; Postprocessing SW: SEMCAD, V1.8 Build 171

Tilt position - High/Area Scan (61x101x1): Measurement grid: dx=15mm, dy=15mm

Maximum value of SAR (interpolated) = 0.214 mW/g

Tilt position - High/Zoom Scan (7x7x7)/Cube 0: Measurement grid: dx=5mm, dy=5mm, dz=5mm

Reference Value = 8.29 V/m; Power Drift = 0.017 dB

Peak SAR (extrapolated) = 0.262 W/kg

SAR(1 g) = 0.200 mW/g; SAR(10 g) = 0.146 mW/g

Maximum value of SAR (measured) = 0.211 mW/g

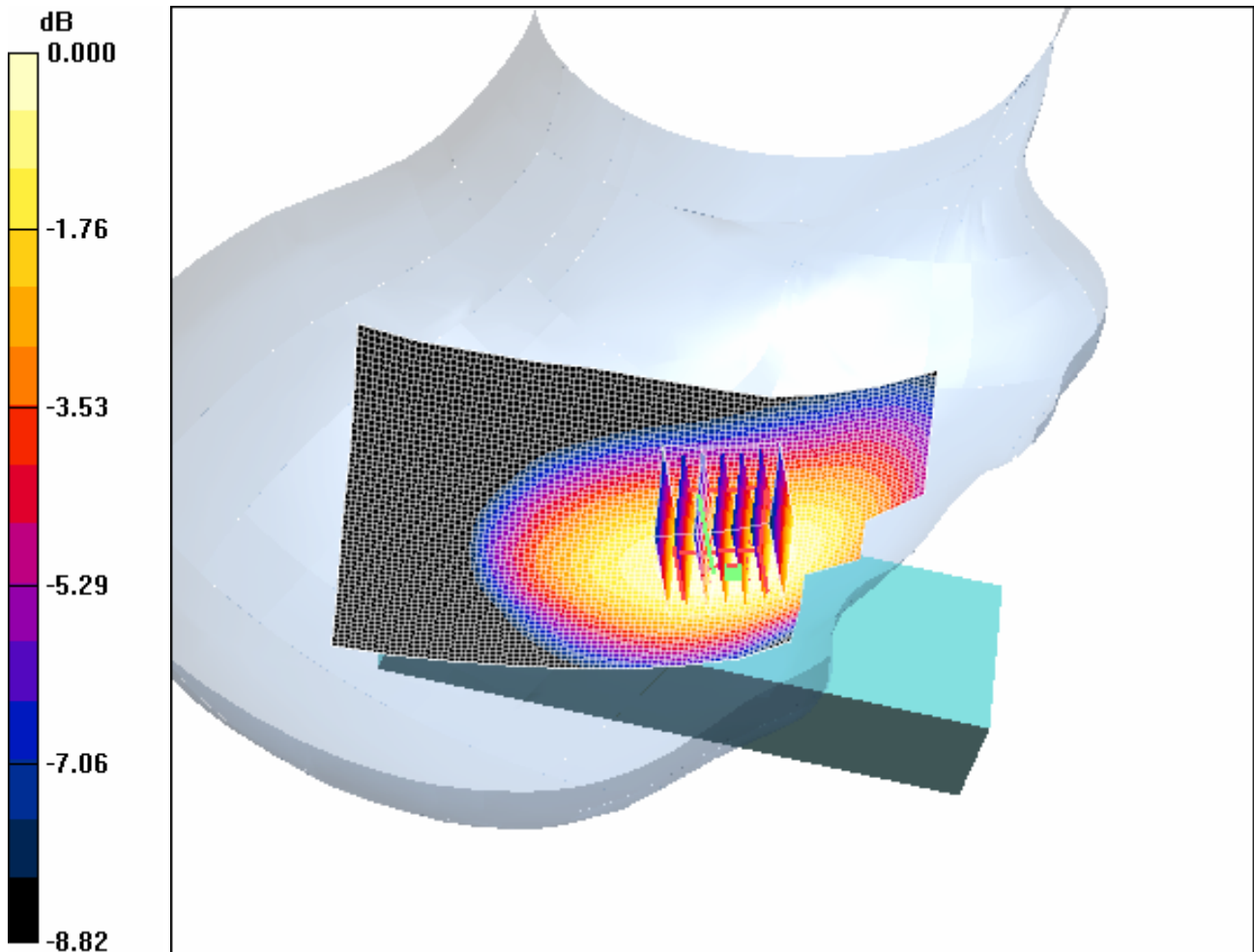

0 dB = 0.211mW/g

4.13 Body-Worn-GSM850-Low

Date/Time: 2006-11-13 9:50:58

Test Laboratory: SGS-GSM

GSM850-Body-Worn-Low-1.5cm

DUT: GSM10142308D; Type: Head; Serial: 0109860000025-5

Communication System: GSM850-GSM Mode; Frequency: 824.2 MHz; Duty Cycle: 1:8.3

Medium: 850-Body Medium parameters used: $f = 824.2$ MHz; $\sigma = 0.929$ mho/m; $r = 54.8$; $\epsilon = 1000$

kg/m³

Phantom section: Flat Section

DASY4 Configuration:

- Probe: ET3DV6 - SN1705; ConvF(5.99, 5.99, 5.99); Calibrated: 2005-12-24
- Sensor-Surface: 4mm (Mechanical Surface Detection)
- Electronics: DAE3 Sn516; Calibrated: 2006-3-8
- Phantom: SAM 12; Type: SAM V4.0; Serial: TP-1283
- Measurement SW: DASY4, V4.7 Build 44; Postprocessing SW: SEMCAD, V1.8 Build 171

Body Worn - Low/Area Scan (51x91x1): Measurement grid: dx=15mm, dy=15mm

Maximum value of SAR (interpolated) = 0.685 mW/g

Body Worn - Low/Zoom Scan (7x7x7) (7x7x7)/Cube 0: Measurement grid: dx=5mm, dy=5mm, dz=5mm

Reference Value = 25.4 V/m; Power Drift = -0.176 dB

Peak SAR (extrapolated) = 0.857 W/kg

SAR(1 g) = 0.627 mW/g; SAR(10 g) = 0.438 mW/g

Maximum value of SAR (measured) = 0.671 mW/g

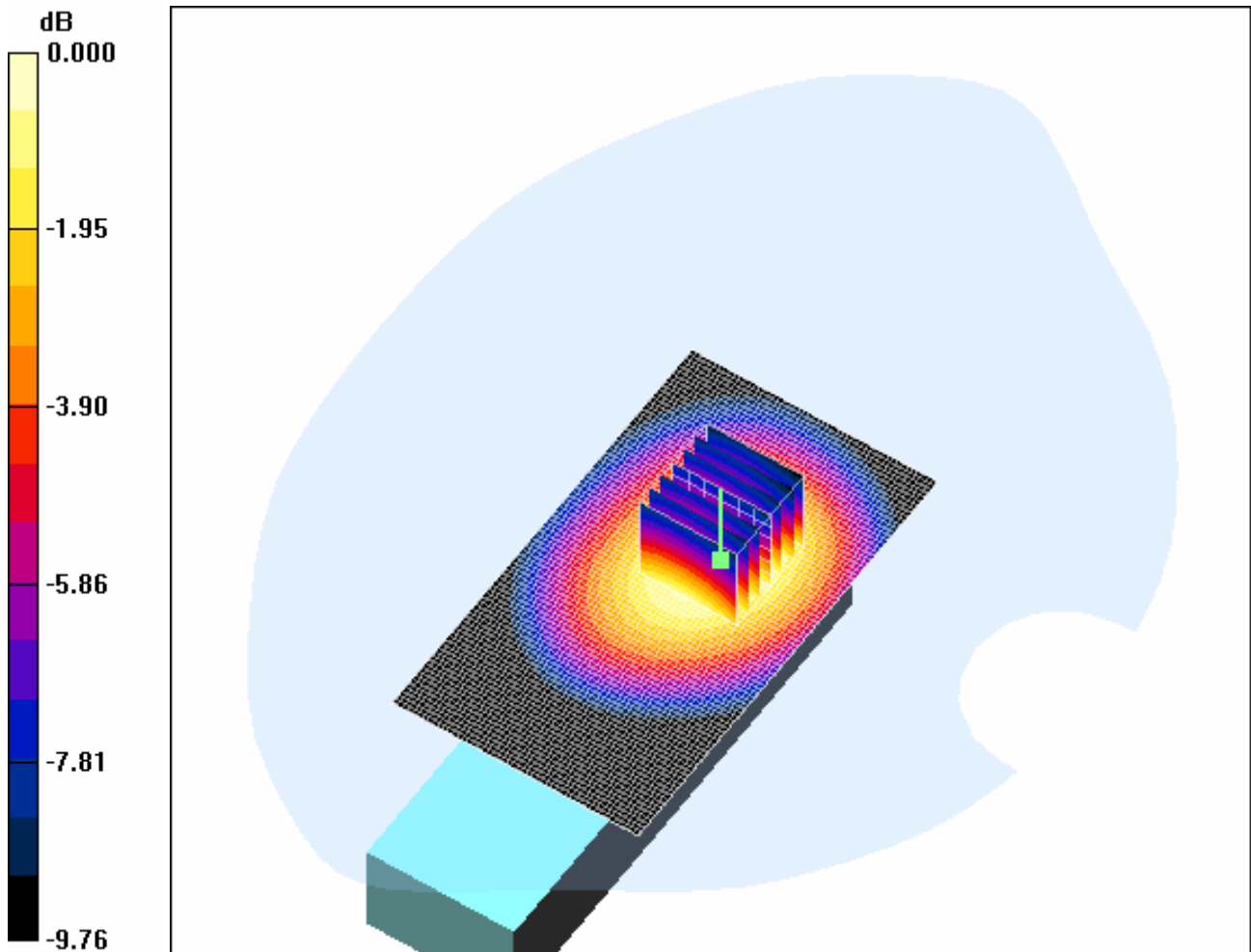

0 dB = 0.671mW/g

4.14 Body-Worn-GSM850-Middle

Date/Time: 2006-11-13 10:15:21

Test Laboratory: SGS-GSM

GSM850-Body-Worn-Middle-1.5cm

DUT: GSM10142308D; Type: Head; Serial: 0109860000025-5

Communication System: GSM850-GSM Mode; Frequency: 836.4 MHz; Duty Cycle: 1:8.3

Medium: 850-Body Medium parameters used: $f = 836.4$ MHz; $\sigma = 0.943$ mho/m; $r = 54.7$; $\epsilon = 1000$

kg/m³

Phantom section: Flat Section

DASY4 Configuration:

- Probe: ET3DV6 - SN1705; ConvF(5.99, 5.99, 5.99); Calibrated: 2005-12-24
- Sensor-Surface: 4mm (Mechanical Surface Detection)
- Electronics: DAE3 Sn516; Calibrated: 2006-3-8
- Phantom: SAM 12; Type: SAM V4.0; Serial: TP-1283
- Measurement SW: DASY4, V4.7 Build 44; Postprocessing SW: SEMCAD, V1.8 Build 171

Body Worn - Middle/Area Scan (51x91x1): Measurement grid: dx=15mm, dy=15mm

Maximum value of SAR (interpolated) = 0.548 mW/g

Body Worn - Middle/Zoom Scan (7x7x7)/Cube 0: Measurement grid: dx=5mm, dy=5mm, dz=5mm

Reference Value = 22.1 V/m; Power Drift = 0.001 dB

Peak SAR (extrapolated) = 0.712 W/kg

SAR(1 g) = 0.512 mW/g; SAR(10 g) = 0.356 mW/g

Maximum value of SAR (measured) = 0.546 mW/g

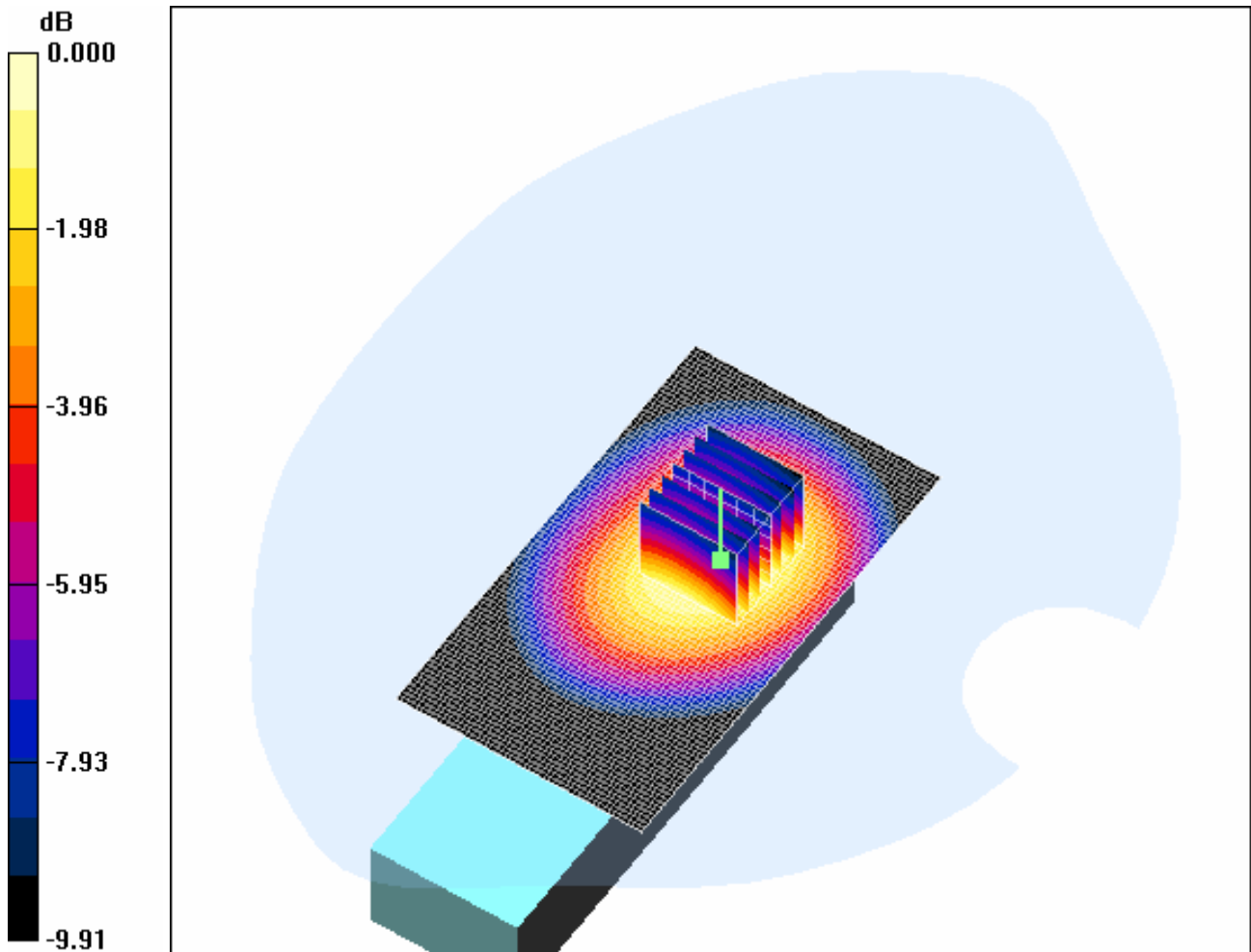

0 dB = 0.546mW/g

4.15 Body-Worn-GSM850-High

Date/Time: 2006-11-13 10:57:20

Test Laboratory: SGS-GSM

GSM850-Body-Worn-High-1.5cm

DUT: GSM10142308D; Type: Head; Serial: 0109860000025-5

Communication System: GSM850-GSM Mode; Frequency: 848.8 MHz; Duty Cycle: 1:8.3

Medium: 850-Body Medium parameters used: $f = 848.8$ MHz; $\sigma = 0.956$ mho/m; $r = 54.7$; $\epsilon = 1000$

kg/m³

Phantom section: Flat Section

DASY4 Configuration:

- Probe: ET3DV6 - SN1705; ConvF(5.99, 5.99, 5.99); Calibrated: 2005-12-24
- Sensor-Surface: 4mm (Mechanical Surface Detection)
- Electronics: DAE3 Sn516; Calibrated: 2006-3-8
- Phantom: SAM 12; Type: SAM V4.0; Serial: TP-1283
- Measurement SW: DASY4, V4.7 Build 44; Postprocessing SW: SEMCAD, V1.8 Build 171

Body Worn - High/Area Scan (51x91x1): Measurement grid: dx=15mm, dy=15mm

Maximum value of SAR (interpolated) = 0.427 mW/g

Body Worn - High/Zoom Scan (7x7x7) (7x7x7)/Cube 0: Measurement grid: dx=5mm, dy=5mm, dz=5mm

Reference Value = 19.1 V/m; Power Drift = -0.046 dB

Peak SAR (extrapolated) = 0.549 W/kg

SAR(1 g) = 0.397 mW/g; SAR(10 g) = 0.275 mW/g

Maximum value of SAR (measured) = 0.425 mW/g

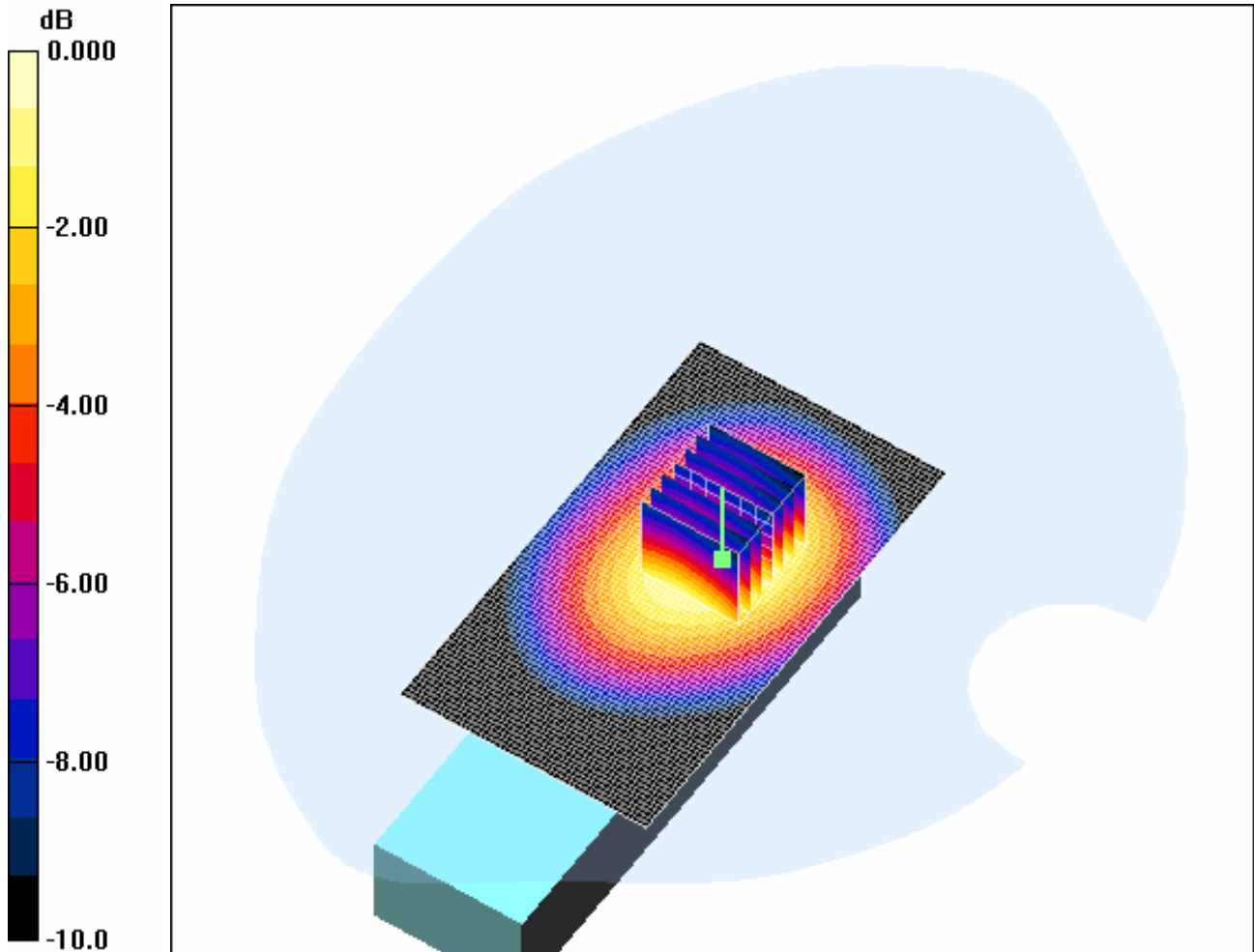

0 dB = 0.425mW/g

4.16 LeftHandSide-Cheek-PCS1900-Low

Date/Time: 2006-11-10 12:26:24

Test Laboratory: SGS-GSM

PCS1900-LeftHandSide-Cheek-Low

DUT: GSM10142308D; Type: Head; Serial: 0109860000025-5

Communication System: PCS1900-GSM Mode; Frequency: 1850.2 MHz; Duty Cycle: 1:8.3

Medium: HSL1900-Head Medium parameters used: $f = 1850.2$ MHz; $\sigma = 1.41$ mho/m; $\epsilon_r = 38.7$; $\mu_r =$

1000 kg/m³

Phantom section: Left Section

DASY4 Configuration:

- Probe: ET3DV6 - SN1705; ConvF(4.81, 4.81, 4.81); Calibrated: 2005-12-24
- Sensor-Surface: 4mm (Mechanical Surface Detection)
- Electronics: DAE3 Sn516; Calibrated: 2006-3-8
- Phantom: SAM 12; Type: SAM V4.0; Serial: TP-1283
- Measurement SW: DASY4, V4.7 Build 44; Postprocessing SW: SEMCAD, V1.8 Build 171

Cheek position - Low/Area Scan (61x101x1): Measurement grid: dx=15mm, dy=15mm

Maximum value of SAR (interpolated) = 0.745 mW/g

Cheek position - Low/Zoom Scan (7x7x7) (7x7x7)/Cube 0: Measurement grid: dx=5mm, dy=5mm, dz=5mm

Reference Value = 7.26 V/m; Power Drift = -0.114 dB

Peak SAR (extrapolated) = 1.09 W/kg

SAR(1 g) = 0.665 mW/g; SAR(10 g) = 0.358 mW/g

Maximum value of SAR (measured) = 0.738 mW/g

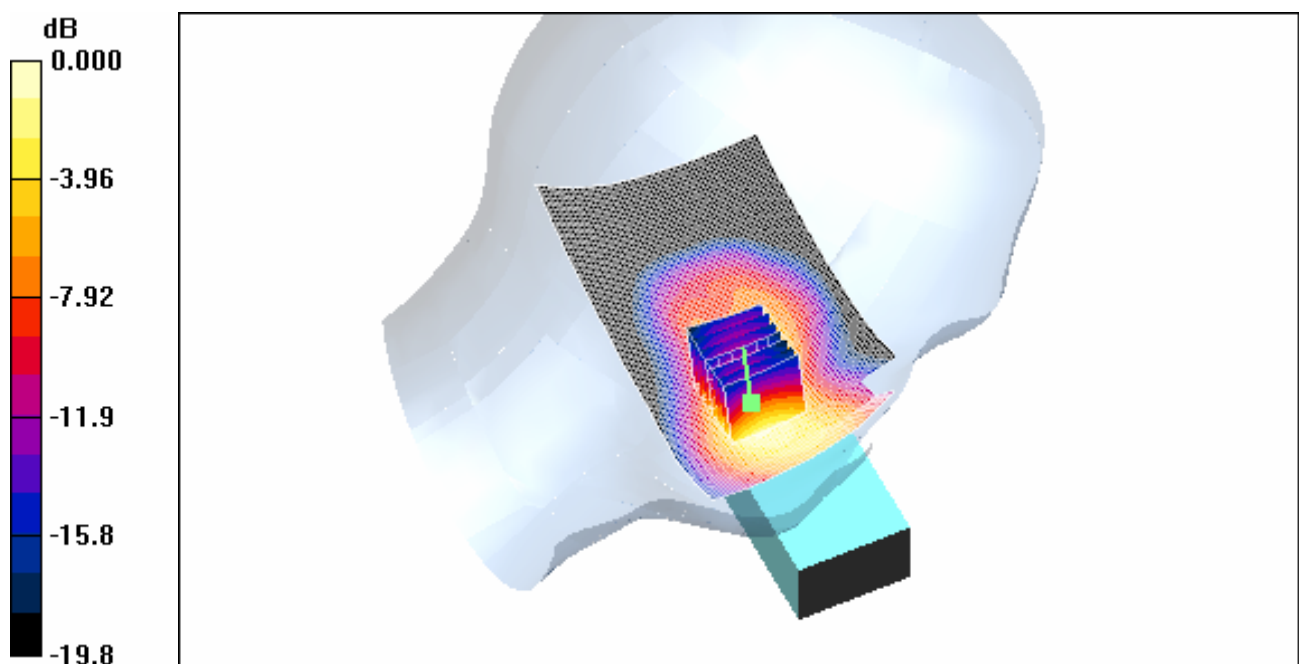

0 dB = 0.738mW/g

4.17 LeftHandSide-Cheek-PCS1900-Middle

Date/Time: 2006-11-10 11:15:58

Test Laboratory: SGS-GSM

PCS1900-LeftHandSide-Cheek-Middle

DUT: GSM10142308D; Type: Head; Serial: 01098600000025-5

Communication System: PCS1900-GSM Mode; Frequency: 1880 MHz; Duty Cycle: 1:8.3

Medium: HSL1900-Head Medium parameters used: $f = 1880$ MHz; $\sigma = 1.44$ mho/m; $\epsilon_r = 38.5$; $\rho = 1000$ kg/m³

Phantom section: Left Section

DASY4 Configuration:

- Probe: ET3DV6 - SN1705; ConvF(4.81, 4.81, 4.81); Calibrated: 2005-12-24
- Sensor-Surface: 4mm (Mechanical Surface Detection)
- Electronics: DAE3 Sn516; Calibrated: 2006-3-8
- Phantom: SAM 12; Type: SAM V4.0; Serial: TP-1283
- Measurement SW: DASY4, V4.7 Build 44; Postprocessing SW: SEMCAD, V1.8 Build 171

Cheek position - Middle/Area Scan (61x101x1): Measurement grid: dx=15mm, dy=15mm

Maximum value of SAR (interpolated) = 0.801 mW/g

Cheek position - Middle/Zoom Scan (7x7x7)/Cube 0: Measurement grid: dx=5mm, dy=5mm, dz=5mm

Reference Value = 7.30 V/m; Power Drift = -0.175 dB

Peak SAR (extrapolated) = 1.18 W/kg

SAR(1 g) = 0.710 mW/g; SAR(10 g) = 0.378 mW/g

Maximum value of SAR (measured) = 0.796 mW/g

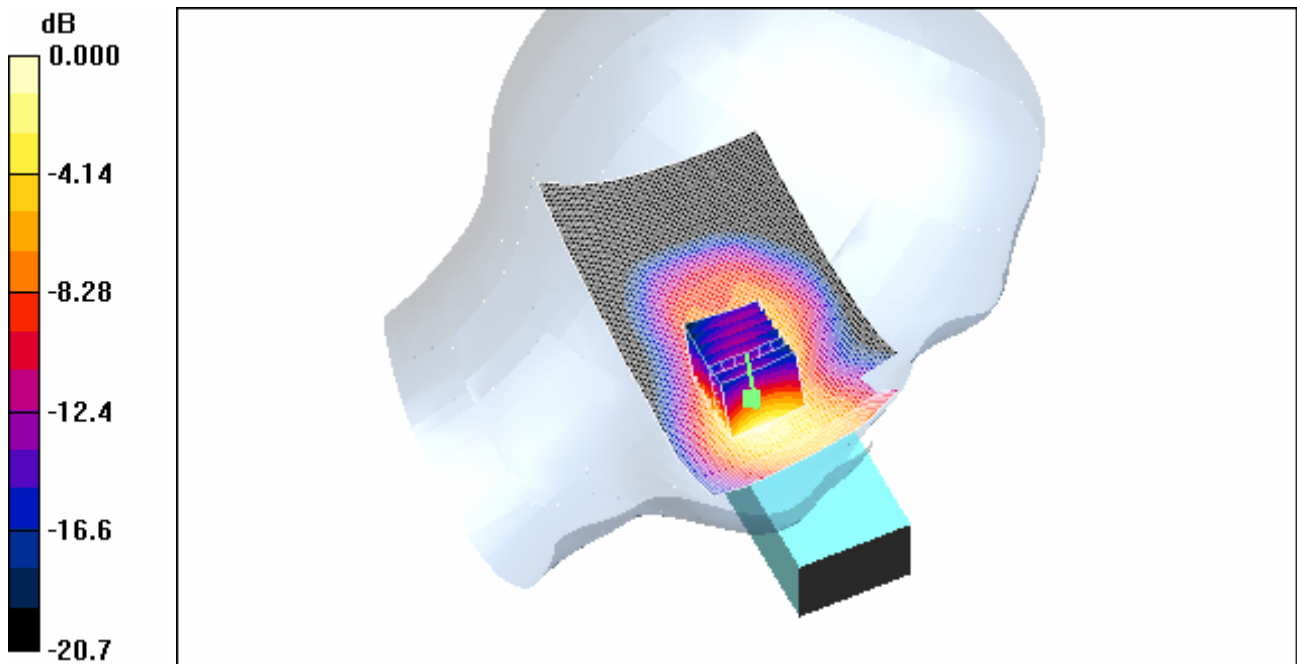

0 dB = 0.796mW/g

4.18 LeftHandSide-Cheek-PCS1900-High

Date/Time: 2006-11-10 13:38:43

Test Laboratory: SGS-GSM

PCS1900-LeftHandSide-Cheek-High

DUT: GSM10142308D; Type: Head; Serial: 0109860000025-5

Communication System: PCS1900-GSM Mode; Frequency: 1909.8 MHz; Duty Cycle: 1:8.3

Medium: HSL1900-Head Medium parameters used: $f = 1909.8 \text{ MHz}$; $\sigma = 1.47 \text{ mho/m}$; $\epsilon_r = 38.4$; $\rho = 1000 \text{ kg/m}^3$

Phantom section: Left Section

DASY4 Configuration:

- Probe: ET3DV6 - SN1705; ConvF(4.81, 4.81, 4.81); Calibrated: 2005-12-24
- Sensor-Surface: 4mm (Mechanical Surface Detection)
- Electronics: DAE3 Sn516; Calibrated: 2006-3-8

- Phantom: SAM 12; Type: SAM V4.0; Serial: TP-1283
- Measurement SW: DASY4, V4.7 Build 44; Postprocessing SW: SEMCAD, V1.8 Build 171

Cheek position - High/Area Scan (61x101x1): Measurement grid: dx=15mm, dy=15mm

Maximum value of SAR (interpolated) = 0.864 mW/g

Cheek position - High/Zoom Scan (7x7x7) (7x7x7)/Cube 0: Measurement grid: dx=5mm, dy=5mm, dz=5mm

Reference Value = 7.48 V/m; Power Drift = -0.094 dB

Peak SAR (extrapolated) = 1.31 W/kg

SAR(1 g) = 0.783 mW/g; SAR(10 g) = 0.415 mW/g

Maximum value of SAR (measured) = 0.863 mW/g

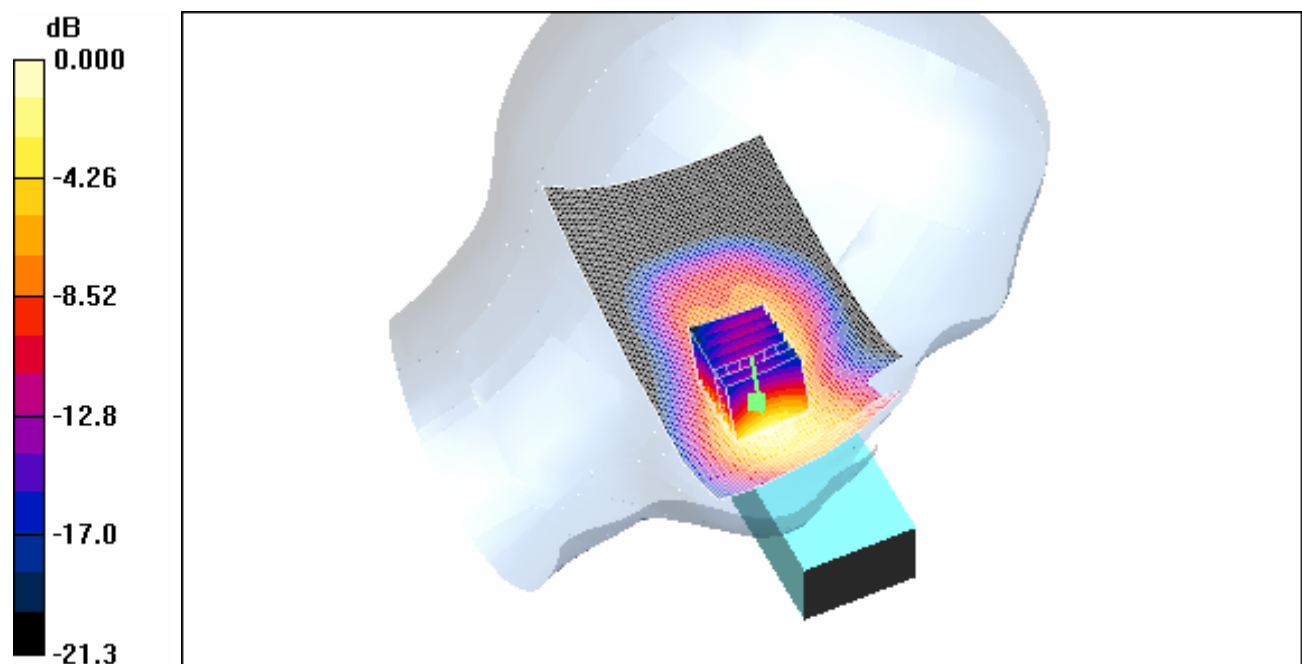

0 dB = 0.863mW/g

4.19 LeftHandSide-Tilt-PCS1900-Low

Date/Time: 2006-11-10 14:46:37

Test Laboratory: SGS-GSM

PCS1900-LeftHandSide-Tilt-Low

DUT: GSM10142308D; Type: Head; Serial: 0109860000025-5

Communication System: PCS1900-GSM Mode; Frequency: 1850.2 MHz; Duty Cycle: 1:8.3

Medium: HSL1900-Head Medium parameters used: $f = 1850.2$ MHz; $\sigma = 1.41$ mho/m; $\tau = 38.7$; $\rho = 1000$ kg/m³

Phantom section: Left Section

DASY4 Configuration:

- Probe: ET3DV6 - SN1705; ConvF(4.81, 4.81, 4.81); Calibrated: 2005-12-24
- Sensor-Surface: 4mm (Mechanical Surface Detection)
- Electronics: DAE3 Sn516; Calibrated: 2006-3-8
- Phantom: SAM 12; Type: SAM V4.0; Serial: TP-1283
- Measurement SW: DASY4, V4.7 Build 44; Postprocessing SW: SEMCAD, V1.8 Build 171

Tilt position - Low/Area Scan (61x101x1): Measurement grid: dx=15mm, dy=15mm

Maximum value of SAR (interpolated) = 0.197 mW/g

Tilt position - Low/Zoom Scan (7x7x7) (7x7x7)/Cube 0: Measurement grid: dx=5mm, dy=5mm, dz=5mm

Reference Value = 9.20 V/m; Power Drift = 0.014 dB

Peak SAR (extrapolated) = 0.249 W/kg

SAR(1 g) = 0.174 mW/g; SAR(10 g) = 0.110 mW/g

Maximum value of SAR (measured) = 0.187 mW/g

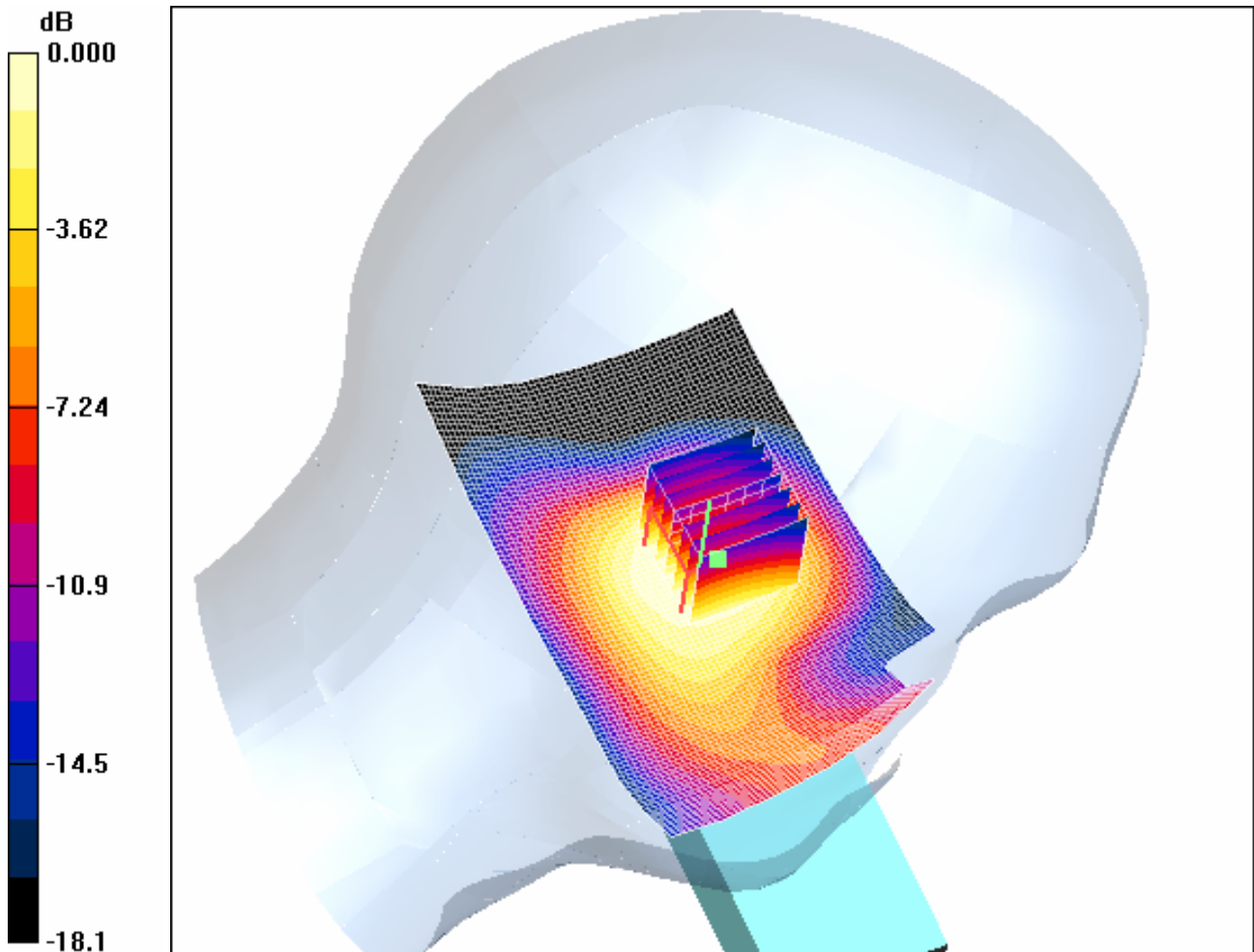

0 dB = 0.187mW/g

4.20 LeftHandSide-Tilt-PCS1900-Middle

Date/Time: 2006-11-10 15:12:20

Test Laboratory: SGS-GSM

PCS1900-LeftHandSide-Tilt-Middle

DUT: GSM10142308D; Type: Head; Serial: 0109860000025-5

Communication System: PCS1900-GSM Mode; Frequency: 1880 MHz; Duty Cycle: 1:8.3

Medium: HSL1900-Head Medium parameters used: $f = 1880$ MHz; $\sigma = 1.44$ mho/m; $\epsilon_r = 38.5$; $\mu_r = 1$

1000 kg/m³

Phantom section: Left Section

DASY4 Configuration:

- Probe: ET3DV6 - SN1705; ConvF(4.81, 4.81, 4.81); Calibrated: 2005-12-24
- Sensor-Surface: 4mm (Mechanical Surface Detection)
- Electronics: DAE3 Sn516; Calibrated: 2006-3-8
- Phantom: SAM 12; Type: SAM V4.0; Serial: TP-1283
- Measurement SW: DASY4, V4.7 Build 44; Postprocessing SW: SEMCAD, V1.8 Build 171

Tilt position - Middle/Area Scan (61x101x1): Measurement grid: dx=15mm, dy=15mm

Maximum value of SAR (interpolated) = 0.209 mW/g

Tilt position - Middle/Zoom Scan (7x7x7)/Cube 0: Measurement grid: dx=5mm, dy=5mm, dz=5mm

Reference Value = 9.36 V/m; Power Drift = -0.039 dB

Peak SAR (extrapolated) = 0.265 W/kg

SAR(1 g) = 0.181 mW/g; SAR(10 g) = 0.115 mW/g

Maximum value of SAR (measured) = 0.194 mW/g

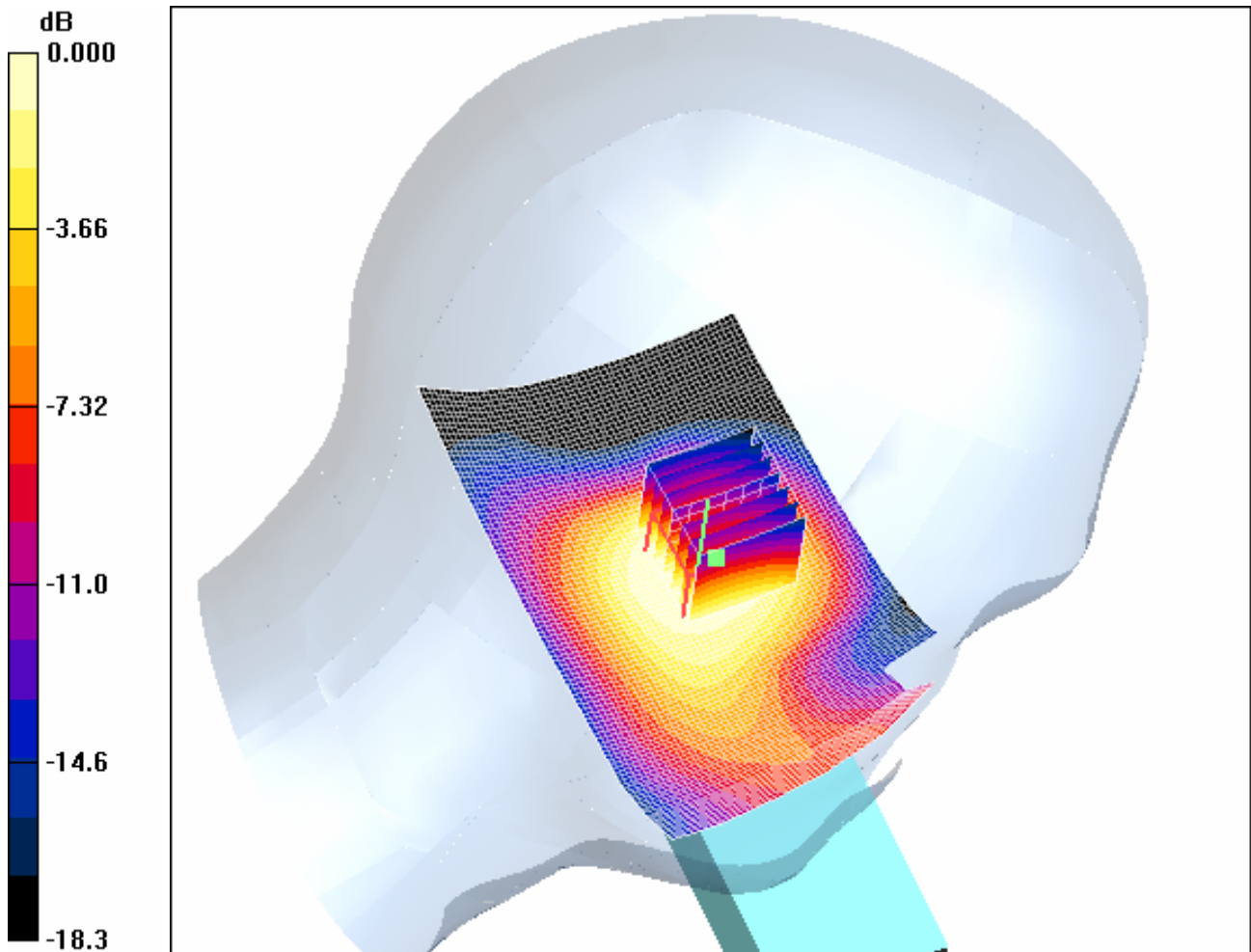

0 dB = 0.194mW/g

4.21 LeftHandSide-Tilt-PCS1900-High

Date/Time: 2006-11-10 14:20:16

Test Laboratory: SGS-GSM

PCS1900-LeftHandSide-Tilt-High

DUT: GSM10142308D; Type: Head; Serial: 0109860000025-5

Communication System: PCS1900-GSM Mode; Frequency: 1909.8 MHz; Duty Cycle: 1:8.3

Medium: HSL1900-Head Medium parameters used: $f = 1909.8 \text{ MHz}$; $\sigma = 1.47 \text{ mho/m}$; $r = 38.4$; $\epsilon =$

1000 kg/m³

Phantom section: Left Section

DASY4 Configuration:

- Probe: ET3DV6 - SN1705; ConvF(4.81, 4.81, 4.81); Calibrated: 2005-12-24
- Sensor-Surface: 4mm (Mechanical Surface Detection)
- Electronics: DAE3 Sn516; Calibrated: 2006-3-8
- Phantom: SAM 12; Type: SAM V4.0; Serial: TP-1283
- Measurement SW: DASY4, V4.7 Build 44; Postprocessing SW: SEMCAD, V1.8 Build 171

Tilt position - High/Area Scan (61x101x1): Measurement grid: dx=15mm, dy=15mm

Maximum value of SAR (interpolated) = 0.224 mW/g

Tilt position - High/Zoom Scan (7x7x7) (7x7x7)/Cube 0: Measurement grid: dx=5mm, dy=5mm, dz=5mm

Reference Value = 9.37 V/m; Power Drift = -0.009 dB

Peak SAR (extrapolated) = 0.285 W/kg

SAR(1 g) = 0.191 mW/g; SAR(10 g) = 0.120 mW/g

Maximum value of SAR (measured) = 0.206 mW/g

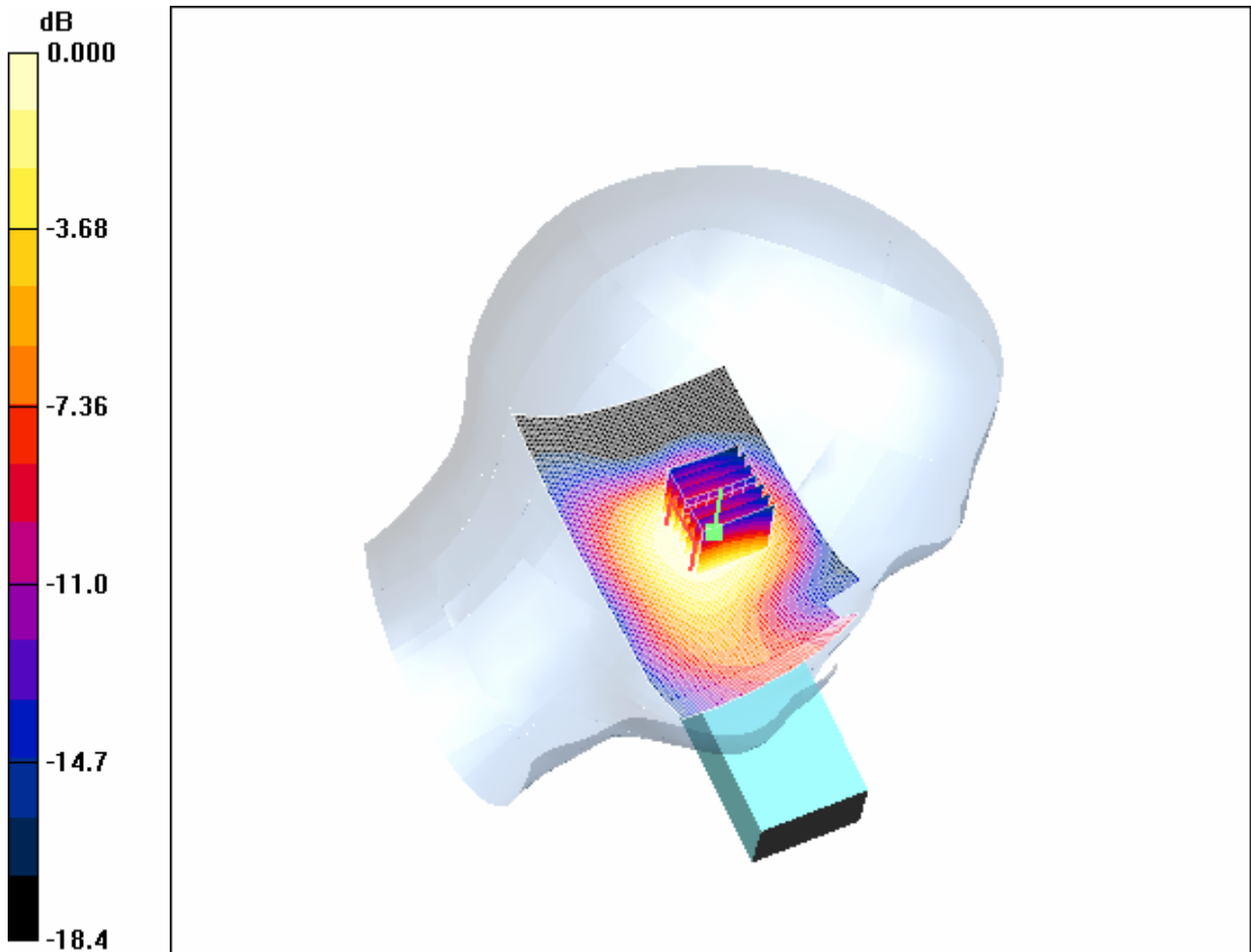

0 dB = 0.206mW/g

4.22 RightHandSide-Cheek-PCS1900-Low

Date/Time: 2006-11-9 16:16:16

Test Laboratory: SGS-GSM

PCS1900-RightHandSide-Cheek-Low

DUT: GSM10142308D; Type: Head; Serial: 0109860000025-5

Communication System: PCS1900-GSM Mode; Frequency: 1850.2 MHz; Duty Cycle: 1:8.3

Medium: HSL1900-Head Medium parameters used: $f = 1850.2$ MHz; $\sigma = 1.41$ mho/m; $\epsilon_r = 38.7$; $\mu_r =$

1000 kg/m³

Phantom section: Right Section

DASY4 Configuration:

- Probe: ET3DV6 - SN1705; ConvF(4.81, 4.81, 4.81); Calibrated: 2005-12-24
- Sensor-Surface: 4mm (Mechanical Surface Detection)
- Electronics: DAE3 Sn516; Calibrated: 2006-3-8
- Phantom: SAM 12; Type: SAM V4.0; Serial: TP-1283
- Measurement SW: DASY4, V4.7 Build 44; Postprocessing SW: SEMCAD, V1.8 Build 171

Cheek position - Low/Area Scan (61x101x1): Measurement grid: dx=15mm, dy=15mm

Maximum value of SAR (interpolated) = 0.780 mW/g

Cheek position - Low/Zoom Scan (7x7x7) (7x7x7)/Cube 0: Measurement grid: dx=5mm, dy=5mm, dz=5mm

Reference Value = 5.00 V/m; Power Drift = 0.113 dB

Peak SAR (extrapolated) = 1.13 W/kg

SAR(1 g) = 0.701 mW/g; SAR(10 g) = 0.378 mW/g

Maximum value of SAR (measured) = 0.787 mW/g

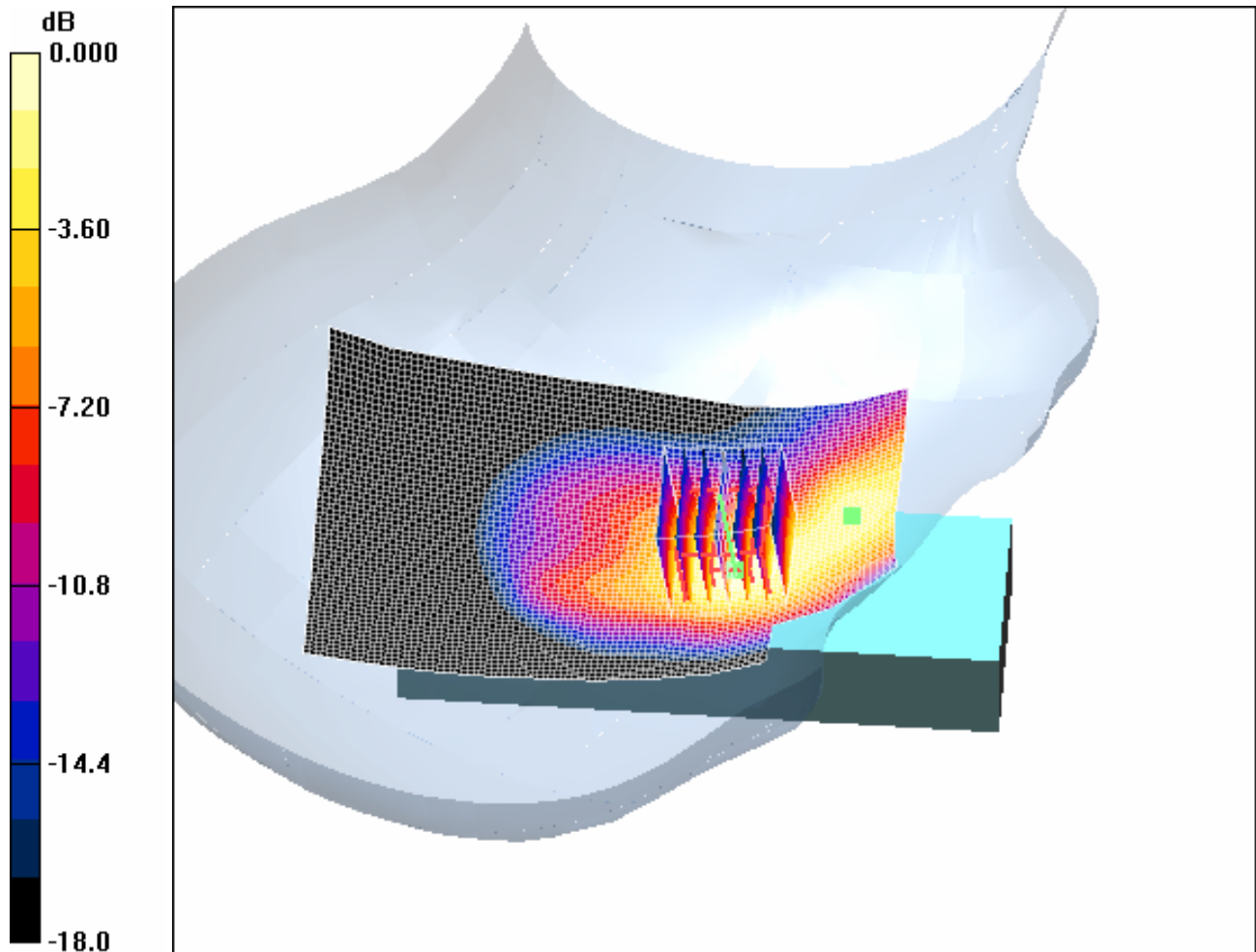

0 dB = 0.787mW/g

4.23 RightHandSide-Cheek-PCS1900-Middle

Date/Time: 2006-11-9 16:43:56

Test Laboratory: SGS-GSM

PCS1900-RightHandSide-Cheek-Middle

DUT: GSM10142308D; Type: Head; Serial: 0109860000025-5

Communication System: PCS1900-GSM Mode; Frequency: 1880 MHz; Duty Cycle: 1:8.3

Medium: HSL1900-Head Medium parameters used: $f = 1880$ MHz; $\sigma = 1.44$ mho/m; $\epsilon_r = 38.5$; $\mu_r =$

1000 kg/m³

Phantom section: Right Section

DASY4 Configuration:

- Probe: ET3DV6 - SN1705; ConvF(4.81, 4.81, 4.81); Calibrated: 2005-12-24
- Sensor-Surface: 4mm (Mechanical Surface Detection)
- Electronics: DAE3 Sn516; Calibrated: 2006-3-8
- Phantom: SAM 12; Type: SAM V4.0; Serial: TP-1283
- Measurement SW: DASY4, V4.7 Build 44; Postprocessing SW: SEMCAD, V1.8 Build 171

Cheek position - Middle/Area Scan (61x101x1): Measurement grid: dx=15mm, dy=15mm

Maximum value of SAR (interpolated) = 0.811 mW/g

Cheek position - Middle/Zoom Scan (7x7x7)/Cube 0: Measurement grid: dx=5mm, dy=5mm,
dz=5mm

Reference Value = 5.23 V/m; Power Drift = -0.095 dB

Peak SAR (extrapolated) = 1.20 W/kg

SAR(1 g) = 0.732 mW/g; SAR(10 g) = 0.392 mW/g

Maximum value of SAR (measured) = 0.825 mW/g

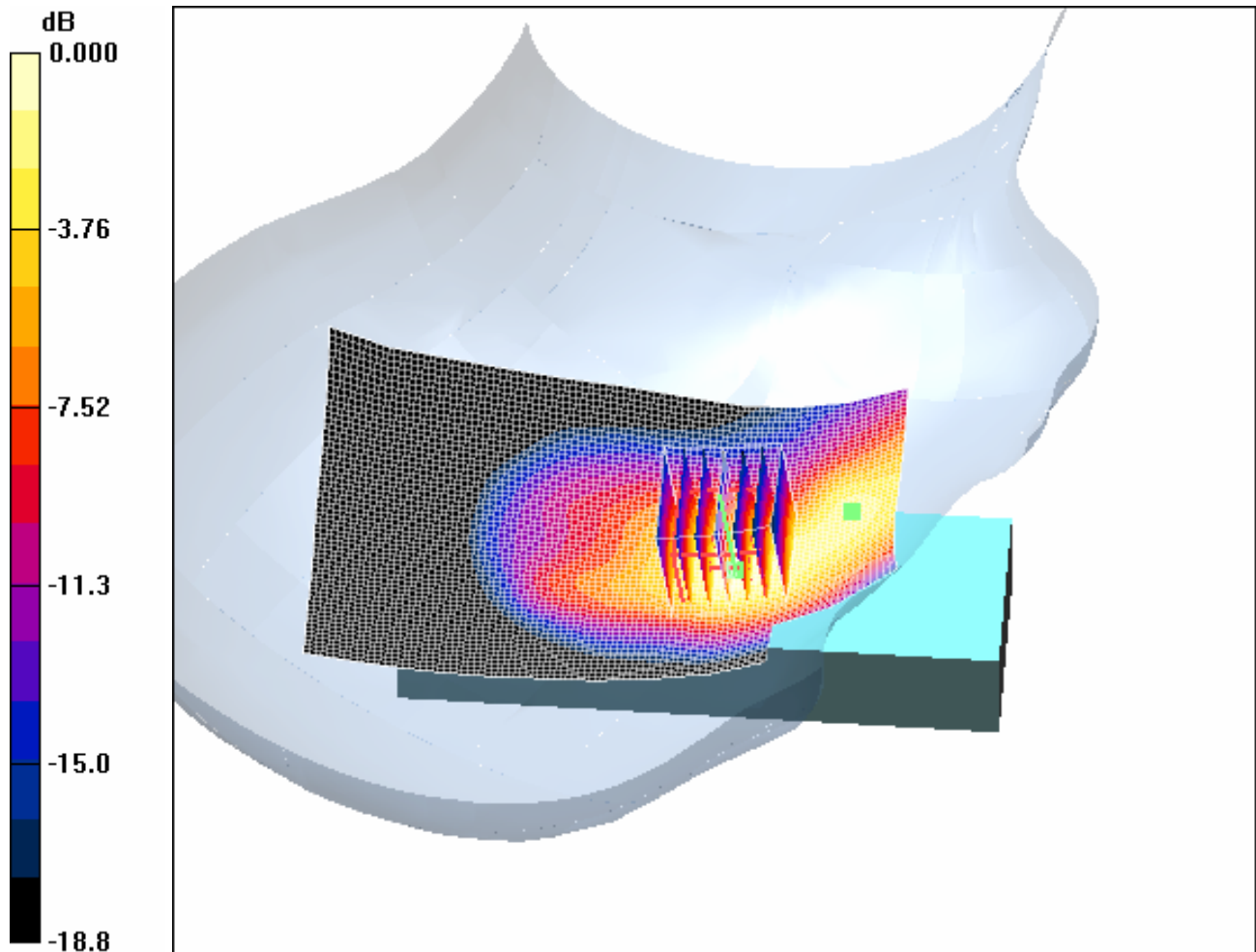

0 dB = 0.825mW/g

4.24 RightHandSide-Cheek-PCS1900-High

Date/Time: 2006-11-10 8:38:17

Test Laboratory: SGS-GSM

PCS1900-RightHandSide-Cheek-High

DUT: GSM10142308D; Type: Head; Serial: 0109860000025-5

Communication System: PCS1900-GSM Mode; Frequency: 1909.8 MHz; Duty Cycle: 1:8.3

Medium: HSL1900-Head Medium parameters used: $f = 1909.8$ MHz; $\sigma = 1.47$ mho/m; $\epsilon_r = 38.4$; $\mu_r =$

1000 kg/m³

Phantom section: Right Section

DASY4 Configuration:

- Probe: ET3DV6 - SN1705; ConvF(4.81, 4.81, 4.81); Calibrated: 2005-12-24
- Sensor-Surface: 4mm (Mechanical Surface Detection)
- Electronics: DAE3 Sn516; Calibrated: 2006-3-8
- Phantom: SAM 12; Type: SAM V4.0; Serial: TP-1283
- Measurement SW: DASY4, V4.7 Build 44; Postprocessing SW: SEMCAD, V1.8 Build 171

Cheek position - High/Area Scan (61x101x1): Measurement grid: dx=15mm, dy=15mm

Maximum value of SAR (interpolated) = 0.898 mW/g

Cheek position - High/Zoom Scan (7x7x7) (7x7x7)/Cube 0: Measurement grid: dx=5mm, dy=5mm, dz=5mm

Reference Value = 5.71 V/m; Power Drift = -0.205 dB

Peak SAR (extrapolated) = 1.32 W/kg

SAR(1 g) = 0.806 mW/g; SAR(10 g) = 0.434 mW/g

Maximum value of SAR (measured) = 0.907 mW/g

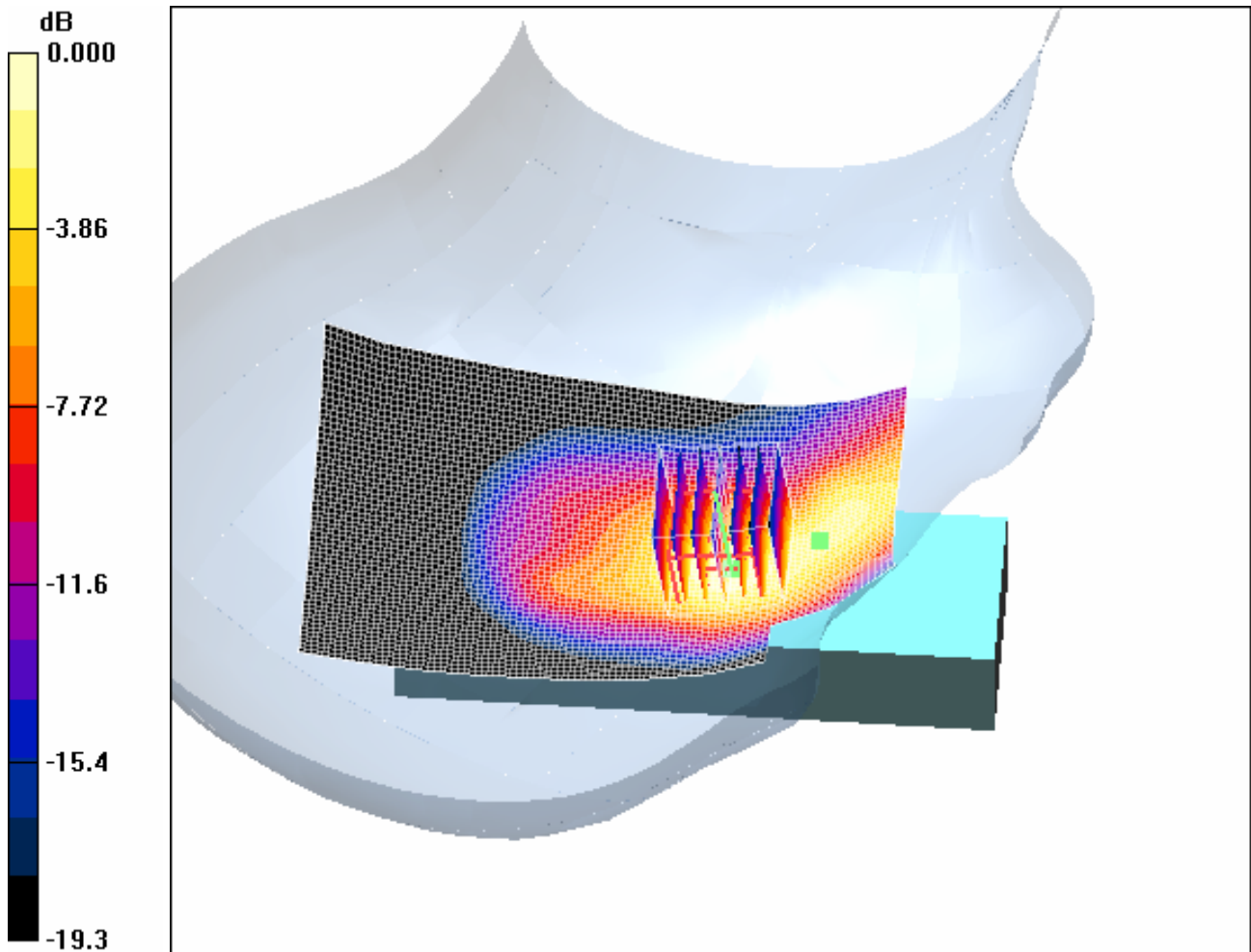

0 dB = 0.907mW/g

4.25 RightHandSide-Tilt-PCS1900-Low

Date/Time: 2006-11-10 9:11:54

Test Laboratory: SGS-GSM

PCS1900-RightHandSide-Tilt-Low

DUT: GSM10142308D; Type: Head; Serial: 0109860000025-5

Communication System: PCS1900-GSM Mode; Frequency: 1850.2 MHz; Duty Cycle: 1:8.3

Medium: HSL1900-Head Medium parameters used: $f = 1850.2$ MHz; $\sigma = 1.41$ mho/m; $\epsilon_r = 38.7$; $\mu_r =$

1000 kg/m³

Phantom section: Right Section

DASY4 Configuration:

- Probe: ET3DV6 - SN1705; ConvF(4.81, 4.81, 4.81); Calibrated: 2005-12-24
- Sensor-Surface: 4mm (Mechanical Surface Detection)
- Electronics: DAE3 Sn516; Calibrated: 2006-3-8
- Phantom: SAM 12; Type: SAM V4.0; Serial: TP-1283
- Measurement SW: DASY4, V4.7 Build 44; Postprocessing SW: SEMCAD, V1.8 Build 171

Tilt position - Low/Area Scan (61x101x1): Measurement grid: dx=15mm, dy=15mm

Maximum value of SAR (interpolated) = 0.229 mW/g

Tilt position - Low/Zoom Scan (7x7x7) (7x7x7)/Cube 0: Measurement grid: dx=5mm, dy=5mm, dz=5mm

Reference Value = 8.89 V/m; Power Drift = 0.007 dB

Peak SAR (extrapolated) = 0.306 W/kg

SAR(1 g) = 0.198 mW/g; SAR(10 g) = 0.120 mW/g

Maximum value of SAR (measured) = 0.218 mW/g

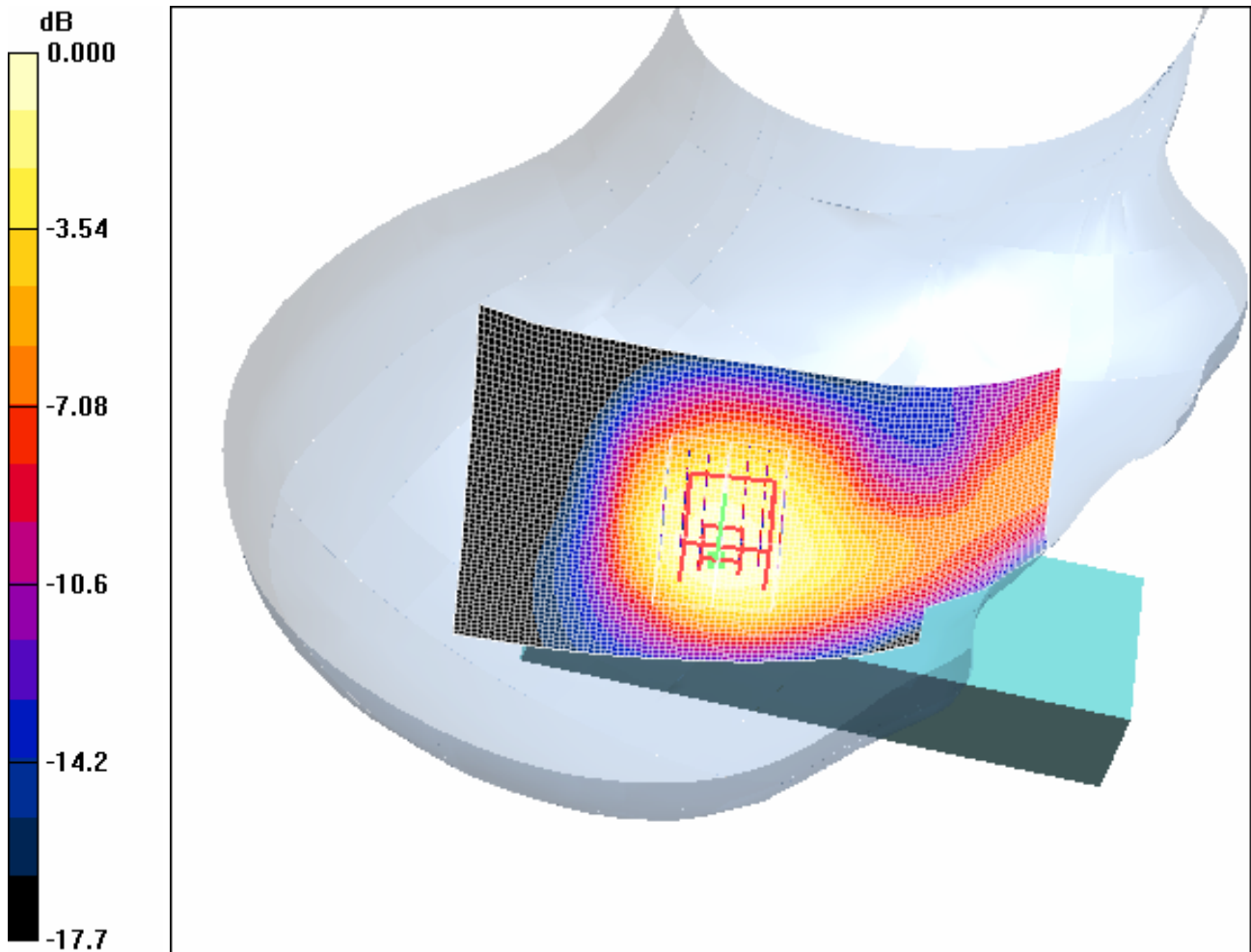

0 dB = 0.218mW/g

4.26 RightHandSide-Tilt-PCS1900-Middle

Date/Time: 2006-11-10 9:37:15

Test Laboratory: SGS-GSM

PCS1900-RightHandSide-Tilt-Middle

DUT: GSM10142308D; Type: Head; Serial: 0109860000025-5

Communication System: PCS1900-GSM Mode; Frequency: 1880 MHz; Duty Cycle: 1:8.3

Medium: HSL1900-Head Medium parameters used: $f = 1880$ MHz; $\sigma = 1.44$ mho/m; $r = 38.5$; $\epsilon =$

1000 kg/m³

Phantom section: Right Section

DASY4 Configuration:

- Probe: ET3DV6 - SN1705; ConvF(4.81, 4.81, 4.81); Calibrated: 2005-12-24
- Sensor-Surface: 4mm (Mechanical Surface Detection)
- Electronics: DAE3 Sn516; Calibrated: 2006-3-8
- Phantom: SAM 12; Type: SAM V4.0; Serial: TP-1283
- Measurement SW: DASY4, V4.7 Build 44; Postprocessing SW: SEMCAD, V1.8 Build 171

Tilt position - Middle/Area Scan (61x101x1): Measurement grid: dx=15mm, dy=15mm

Maximum value of SAR (interpolated) = 0.236 mW/g

Tilt position - Middle/Zoom Scan (7x7x7)/Cube 0: Measurement grid: dx=5mm, dy=5mm, dz=5mm

Reference Value = 8.85 V/m; Power Drift = -0.021 dB

Peak SAR (extrapolated) = 0.313 W/kg

SAR(1 g) = 0.201 mW/g; SAR(10 g) = 0.121 mW/g

Maximum value of SAR (measured) = 0.222 mW/g

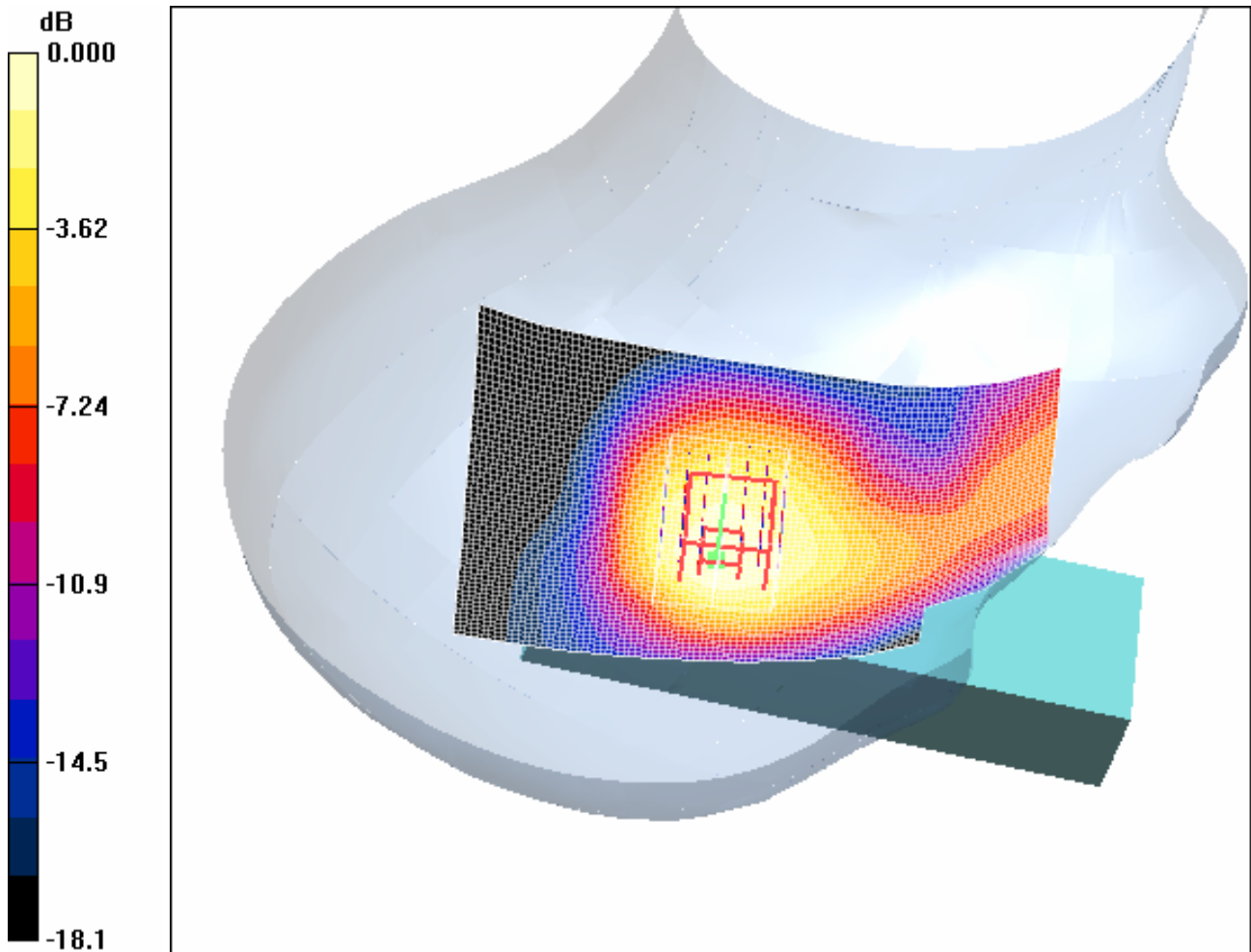

0 dB = 0.222mW/g

4.27 RightHandSide-Tilt-PCS1900-High

Date/Time: 2006-11-10 10:41:52

Test Laboratory: SGS-GSM

PCS1900-RightHandSide-Tilt-High

DUT: GSM10142308D; Type: Head; Serial: 0109860000025-5

Communication System: PCS1900-GSM Mode; Frequency: 1909.8 MHz; Duty Cycle: 1:8.3

Medium: HSL1900-Head Medium parameters used: $f = 1909.8$ MHz; $\sigma = 1.47$ mho/m; $\epsilon_r = 38.4$; $\mu_r =$

1000 kg/m³

Phantom section: Right Section

DASY4 Configuration:

- Probe: ET3DV6 - SN1705; ConvF(4.81, 4.81, 4.81); Calibrated: 2005-12-24
- Sensor-Surface: 4mm (Mechanical Surface Detection)
- Electronics: DAE3 Sn516; Calibrated: 2006-3-8
- Phantom: SAM 12; Type: SAM V4.0; Serial: TP-1283
- Measurement SW: DASY4, V4.7 Build 44; Postprocessing SW: SEMCAD, V1.8 Build 171

Tilt position - High/Area Scan (61x101x1): Measurement grid: dx=15mm, dy=15mm

Maximum value of SAR (interpolated) = 0.246 mW/g

Tilt position - High/Zoom Scan (7x7x7) (7x7x7)/Cube 0: Measurement grid: dx=5mm, dy=5mm, dz=5mm

Reference Value = 8.87 V/m; Power Drift = -0.022 dB

Peak SAR (extrapolated) = 0.326 W/kg

SAR(1 g) = 0.208 mW/g; SAR(10 g) = 0.125 mW/g

Maximum value of SAR (measured) = 0.228 mW/g

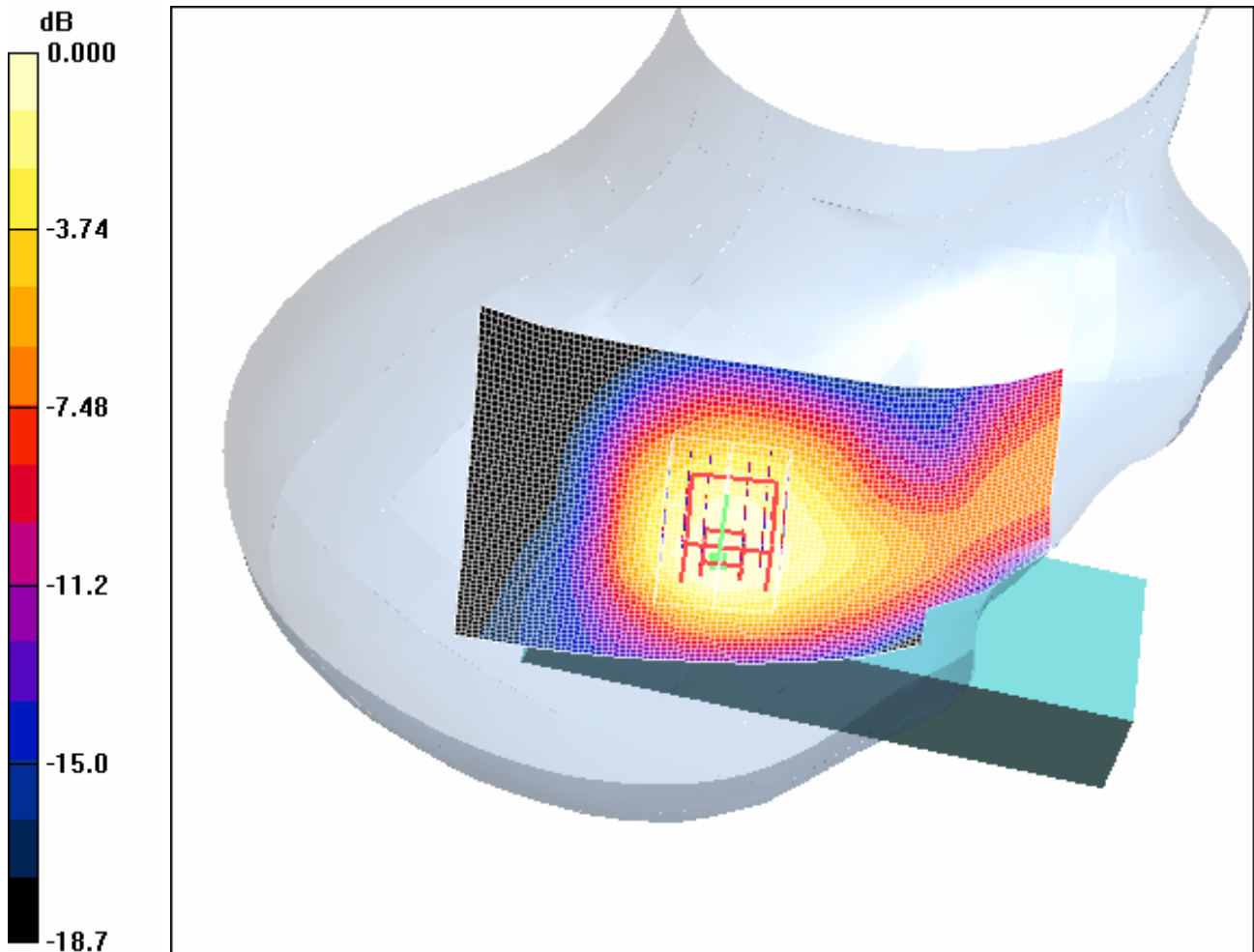

0 dB = 0.228mW/g

4.28 Body-Worn-PCS1900-Low

Date/Time: 2006-11-13 16:16:30

Test Laboratory: SGS-GSM

PCS1900-Body-Worn-Low-1.5cm

DUT: GSM10142308D; Type: Head; Serial: 0109860000025-5

Communication System: PCS1900-GSM Mode; Frequency: 1850.2 MHz; Duty Cycle: 1:8.3

Medium: 1900-Body Medium parameters used: $f = 1850.2$ MHz; $\sigma = 1.51$ mho/m; $\epsilon_r = 53.5$; $\epsilon_0 = 1000$

kg/m³

Phantom section: Flat Section

DASY4 Configuration:

- Probe: ET3DV6 - SN1705; ConvF(4.19, 4.19, 4.19); Calibrated: 2005-12-24
- Sensor-Surface: 4mm (Mechanical Surface Detection)
- Electronics: DAE3 Sn516; Calibrated: 2006-3-8
- Phantom: SAM 12; Type: SAM V4.0; Serial: TP-1283
- Measurement SW: DASY4, V4.7 Build 44; Postprocessing SW: SEMCAD, V1.8 Build 171

Body Worn - Low/Area Scan (51x91x1): Measurement grid: dx=15mm, dy=15mm

Maximum value of SAR (interpolated) = 0.349 mW/g

Body Worn - Low/Zoom Scan (7x7x7) (7x7x7)/Cube 0: Measurement grid: dx=5mm, dy=5mm, dz=5mm

Reference Value = 12.0 V/m; Power Drift = -0.113 dB

Peak SAR (extrapolated) = 0.514 W/kg

SAR(1 g) = 0.320 mW/g; SAR(10 g) = 0.198 mW/g

Maximum value of SAR (measured) = 0.347 mW/g

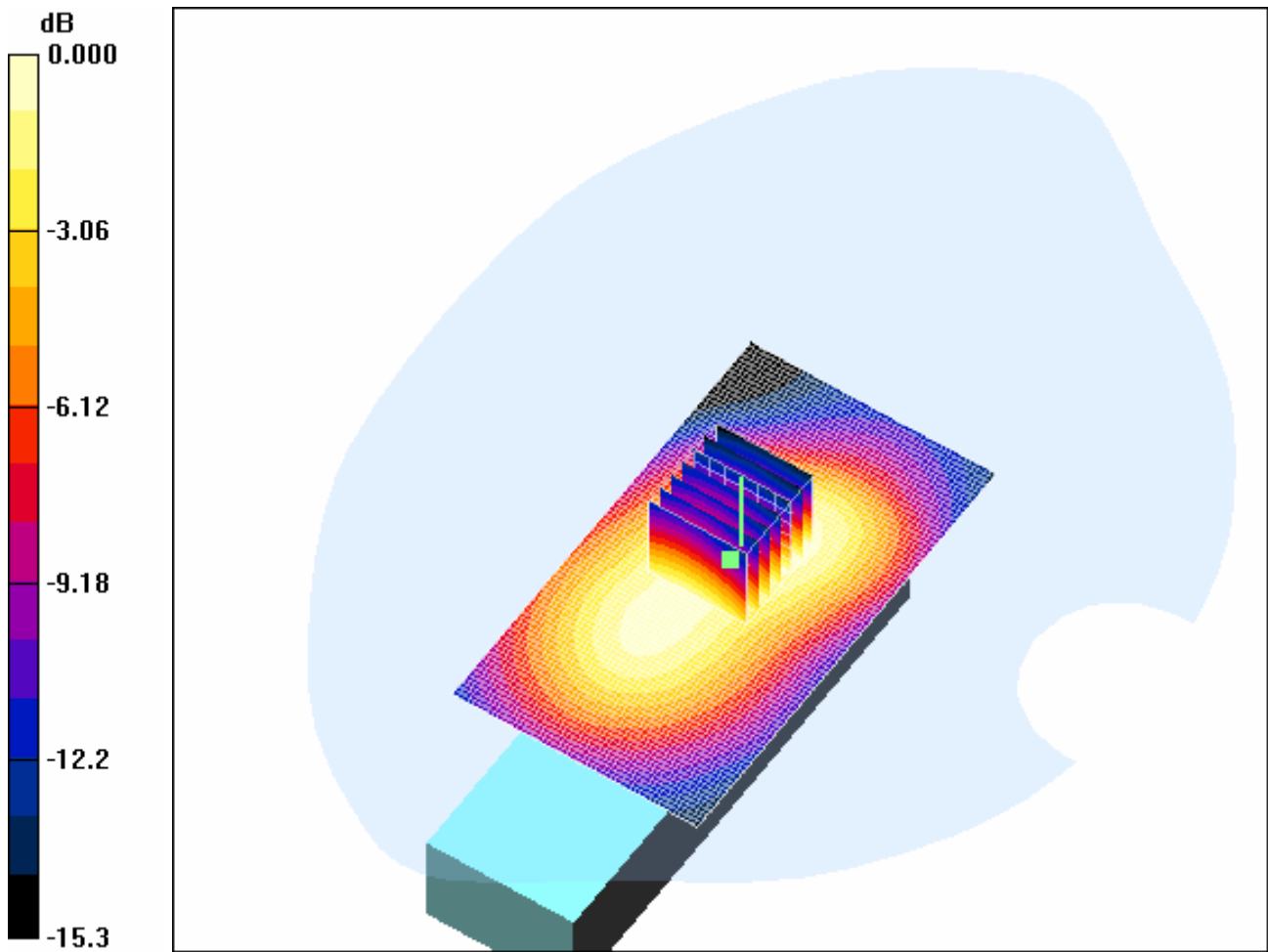

0 dB = 0.347mW/g

4.29 Body-Worn-PCS1900-Middle

Date/Time: 2006-11-13 16:44:25

Test Laboratory: SGS-GSM

PCS1900-Body-Worn-Middle-1.5cm

DUT: GSM10142308D; Type: Head; Serial: 0109860000025-5

Communication System: PCS1900-GSM Mode; Frequency: 1880 MHz; Duty Cycle: 1:8.3

Medium: 1900-Body Medium parameters used: $f = 1880$ MHz; $\sigma = 1.55$ mho/m; $r = 53.6$; $\epsilon = 1000$

kg/m³

Phantom section: Flat Section

DASY4 Configuration:

- Probe: ET3DV6 - SN1705; ConvF(4.19, 4.19, 4.19); Calibrated: 2005-12-24
- Sensor-Surface: 4mm (Mechanical Surface Detection)
- Electronics: DAE3 Sn516; Calibrated: 2006-3-8
- Phantom: SAM 12; Type: SAM V4.0; Serial: TP-1283
- Measurement SW: DASY4, V4.7 Build 44; Postprocessing SW: SEMCAD, V1.8 Build 171

Body Worn - Middle/Area Scan (51x91x1): Measurement grid: dx=15mm, dy=15mm

Maximum value of SAR (interpolated) = 0.367 mW/g

Body Worn - Middle/Zoom Scan (7x7x7)/Cube 0: Measurement grid: dx=5mm, dy=5mm, dz=5mm

Reference Value = 12.9 V/m; Power Drift = -0.024 dB

Peak SAR (extrapolated) = 0.567 W/kg

SAR(1 g) = 0.335 mW/g; SAR(10 g) = 0.200 mW/g

Maximum value of SAR (measured) = 0.363 mW/g

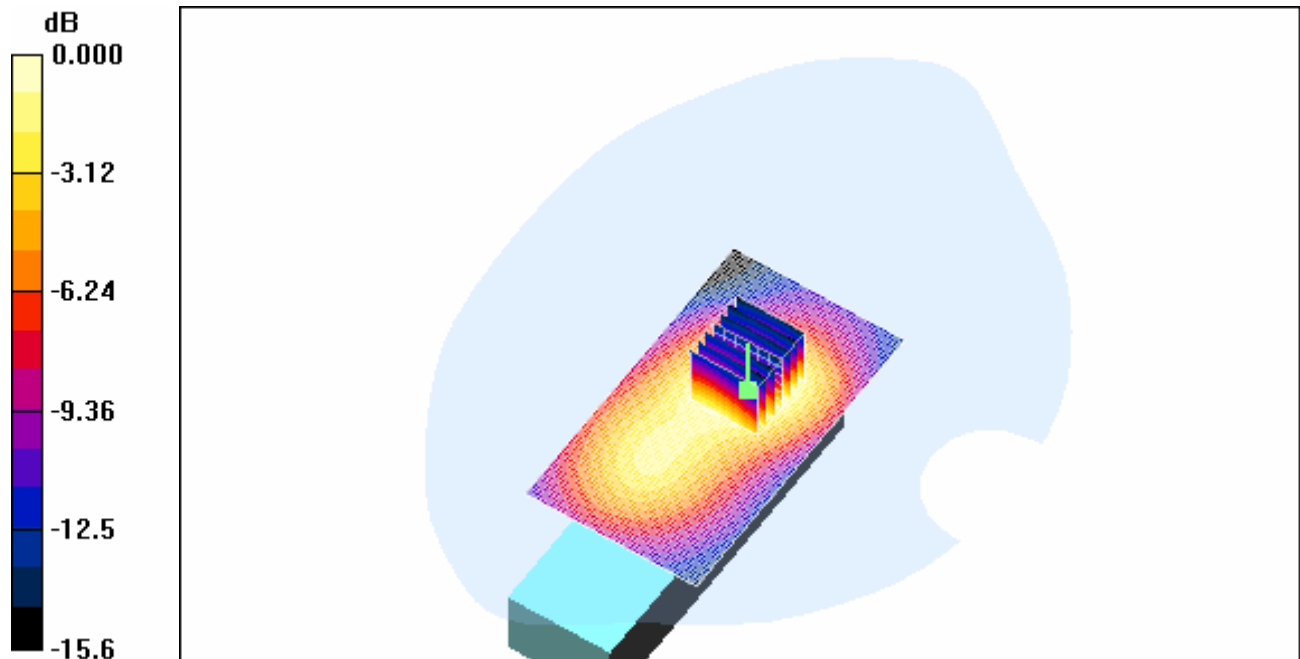

0 dB = 0.363mW/g

4.30 Body-Worn-PCS1900-High

Date/Time: 2006-11-13 17:05:59

Test Laboratory: SGS-GSM

PCS1900-Body-Worn-High-1.5cm

DUT: GSM10142308D; Type: Head; Serial: 01098600000025-5

Communication System: PCS1900-GSM Mode; Frequency: 1909.8 MHz; Duty Cycle: 1:8.3

Medium: 1900-Body Medium parameters used: $f = 1909.8$ MHz; $\sigma = 1.59$ mho/m; $\rho = 53.5$; $\rho = 1000$ kg/m³

Phantom section: Flat Section

DASY4 Configuration:

- Probe: ET3DV6 - SN1705; ConvF(4.19, 4.19, 4.19); Calibrated: 2005-12-24
- Sensor-Surface: 4mm (Mechanical Surface Detection)
- Electronics: DAE3 Sn516; Calibrated: 2006-3-8
- Phantom: SAM 12; Type: SAM V4.0; Serial: TP-1283
- Measurement SW: DASY4, V4.7 Build 44; Postprocessing SW: SEMCAD, V1.8 Build 171

Body Worn - High/Area Scan (51x91x1): Measurement grid: dx=15mm, dy=15mm

Maximum value of SAR (interpolated) = 0.421 mW/g

Body Worn - High/Zoom Scan (7x7x7) (7x7x7)/Cube 0: Measurement grid: dx=5mm, dy=5mm, dz=5mm

Reference Value = 13.8 V/m; Power Drift = -0.025 dB

Peak SAR (extrapolated) = 0.649 W/kg

SAR(1 g) = 0.382 mW/g; SAR(10 g) = 0.228 mW/g

Maximum value of SAR (measured) = 0.412 mW/g

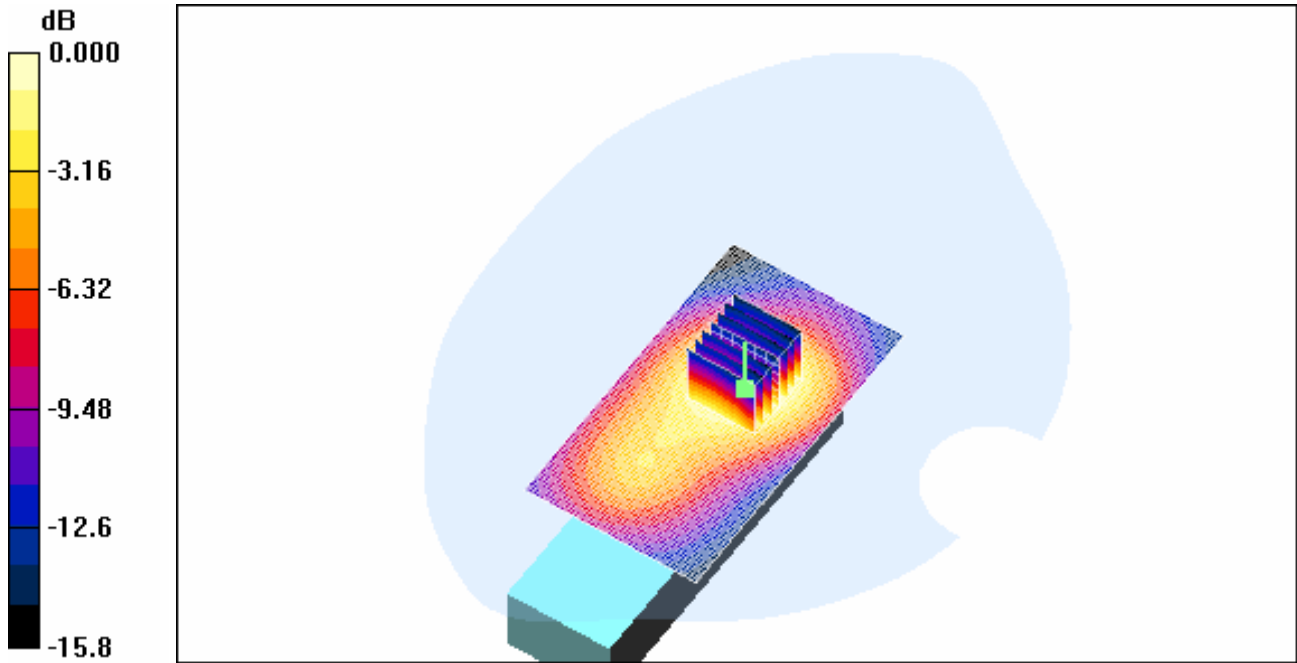

0 dB = 0.412mW/g

Appendix

1. Photographs of Test Setup

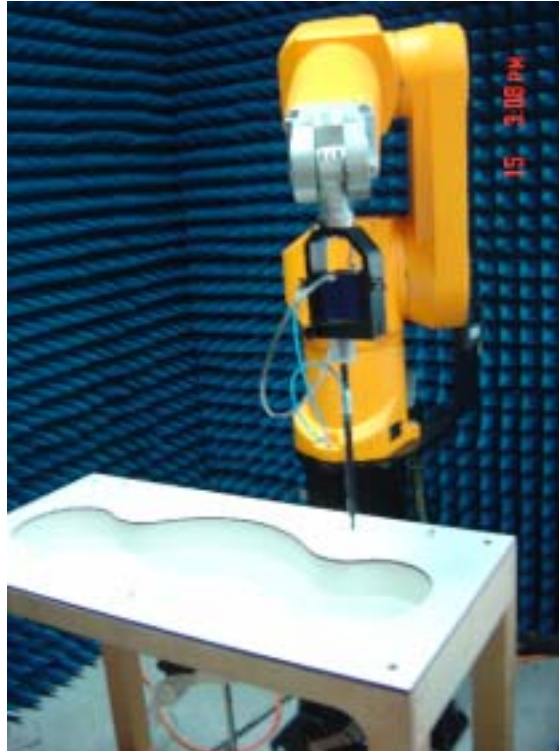

Fig.1 Photograph of the SAR measurement System

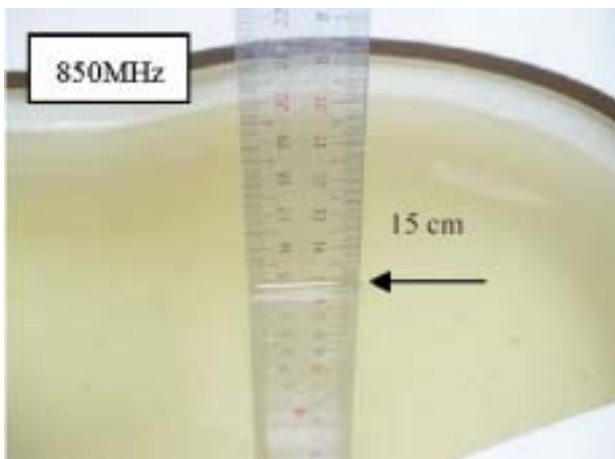

Fig.2 Photograph of the Tissue Simulant Fluid Liquid depth 15cm for Left-Head Side

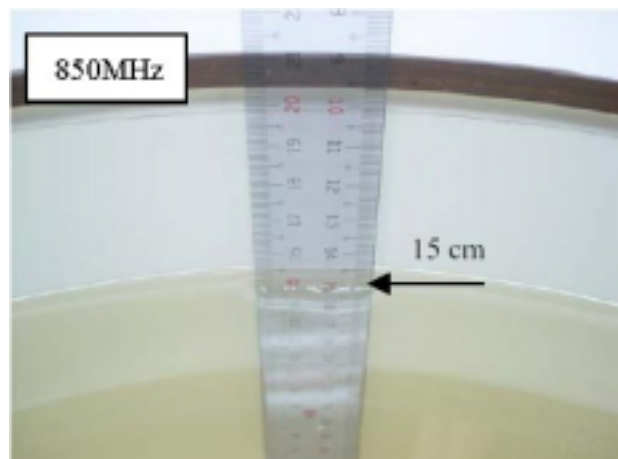

Fig.3 Photograph of the Tissue Simulant Liquid depth 15cm for Body-Worn

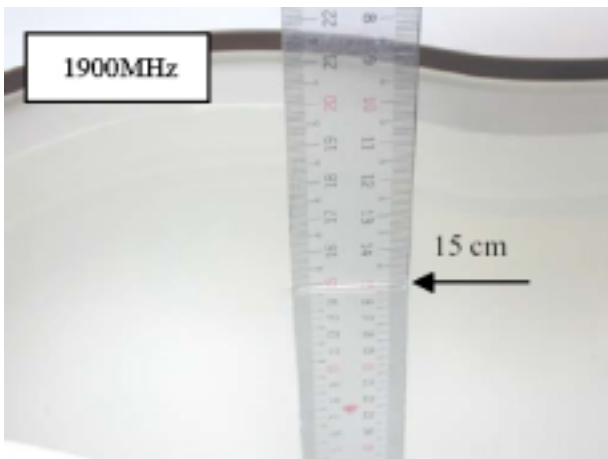

Fig.4 Photograph of the Tissue Simulant Fluid Liquid depth 15cm for Right-Head Side

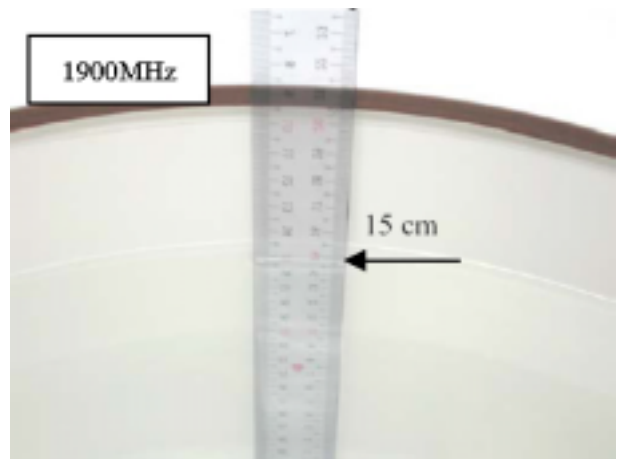

Fig.5 Photograph of the Tissue Simulant Liquid depth 15cm for Body-Worn



Fig.6 Photograph of the Left Hand Side Cheek status

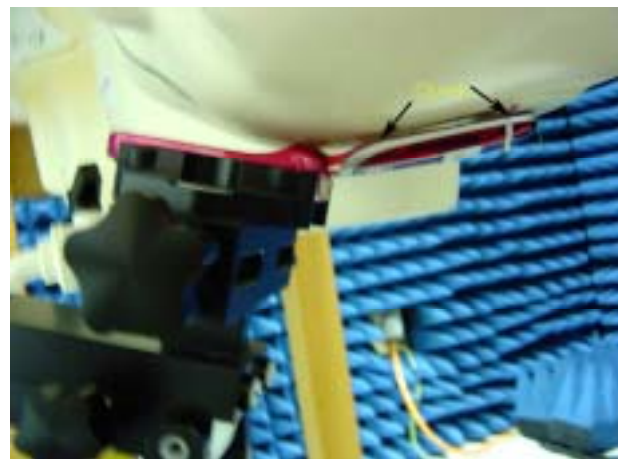

Fig.7 Photograph of the Left Hand Side Tilt status



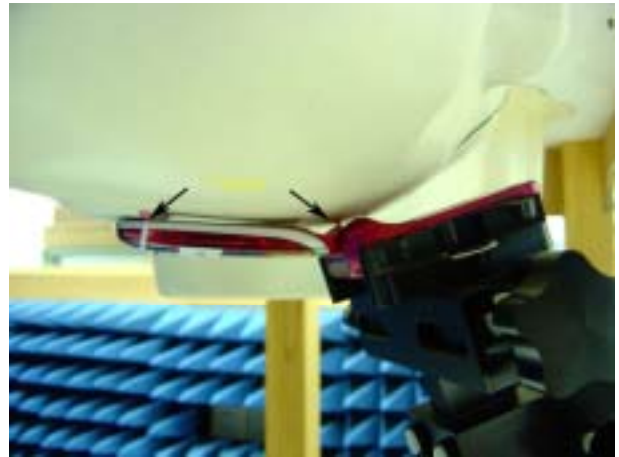
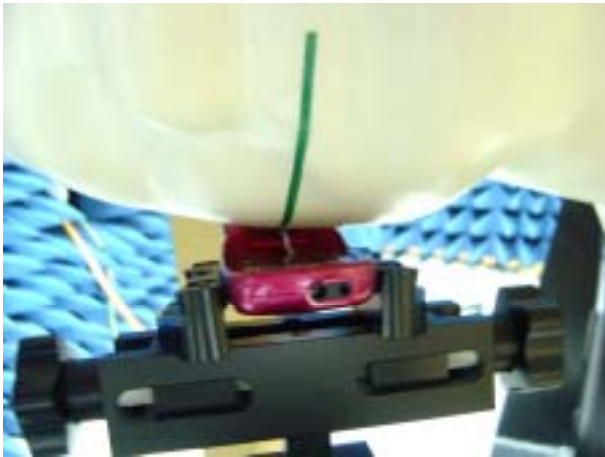

Fig.8 Photograph of the Right Hand Side Cheek status

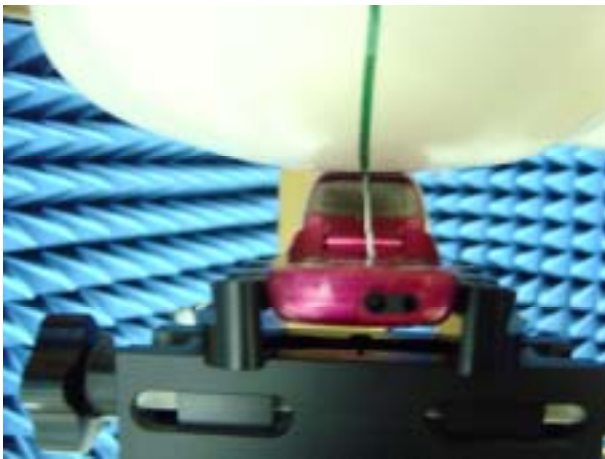

Fig.9 Photograph of the Right Hand Side Tilt status



Fig.10 Photograph of the BodyWorn status

2. Photographs of the EUT

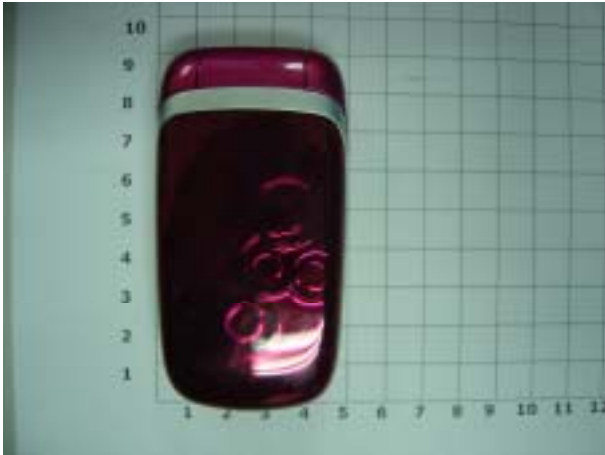

Fig.11 Front View



Fig.12 Back View

3. Photographs of the battery

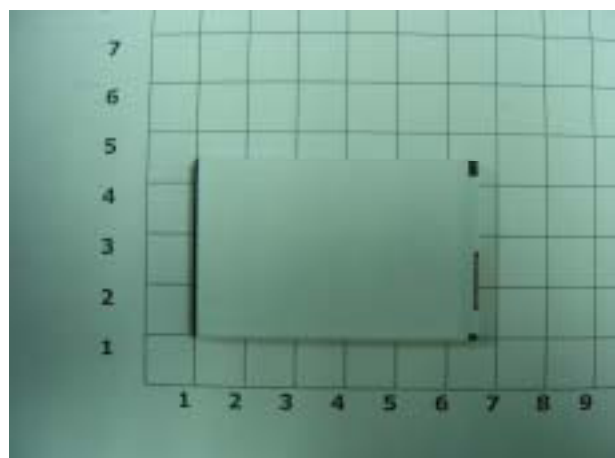

Fig.13 Front view of battery

Fig.14 Back view of battery

4. Photograph of the charger



Fig.15 Charger

5. Probe Calibration certification

Calibration Laboratory of
Schmid & Partner
Engineering AG
Zeughausstrasse 45, 8004 Zurich, Switzerland



S Schweizerischer Kalibrierdienst
S Service suisse d'Etalonnage
S Servizio svizzero di taratura
S Swiss Calibration Service

Accredited by the Swiss Federal Office of Metrology and Accreditation
The Swiss Accreditation Service is one of the signatories to the EA
Multilateral Agreement for the recognition of calibration certificates

Accreditation No.: SCS 108

Client **MTT**

Certificate No: ET3-1705_Oct05

CALIBRATION CERTIFICATE

Object: **ET3DV6 - SN-1705**

Calibration procedure(s): **QA CAL-01.v5
Calibration procedure for dosimetric E-field probes**

Calibration date: **October 24, 2005**

Condition of the calibrated item: **In Tolerance**

This calibration certificate documents the traceability to national standards, which realize the physical units of measurements (SI).
The measurements and the uncertainties with confidence probability are given on the following pages and are part of the certificate.

All calibrations have been conducted in the closed laboratory facility: environment temperature (22 ± 3)°C and humidity < 70%.

Calibration Equipment used (MATE critical for calibration)

Primary Standards	ID #	Cal Date (Calibrated by, Certificate No.)	Scheduled Calibration
Power meter E4116B	0B41293874	3-May-05 (METAS, No. 251-00499)	May-05
Power sensor E4412A	MY41485277	3-May-05 (METAS, No. 251-00498)	May-05
Power sensor E4412A	MY41485087	3-May-05 (METAS, No. 251-00498)	May-05
Reference 3 dB Attenuator	SN: 55054 (3x)	11-Aug-05 (METAS, No. 251-00499)	Aug-05
Reference 20 dB Attenuator	SN: 55086 (20x)	3-May-05 (METAS, No. 251-00497)	May-05
Reference 30 dB Attenuator	SN: 55129 (30x)	11-Aug-05 (METAS, No. 251-00500)	Aug-05
Reference Probe ES30V2	SN: 3013	7-Jan-05 (SPEAG, No. E83-3013_Jan05)	Jan-05
DAE4	SN: 654	29-Nov-04 (SPEAG, No. DAE4-654_Nov04)	Nov-05

Secondary Standards	ID #	Check Date (In house)	Scheduled Check
RF generator HP 8948C	US3942L01700	4-Aug-05 (SPEAG, in house check Dec-03)	In house check: Dec-05
Network Analyser HP 8733E	US37360565	18-Oct-01 (SPEAG, in house check Nov-04)	In house check: Nov-05

Calibrated by	Name	Function	Signature
	Mark Vetterli	Laboratory Technician	<i>[Signature]</i>
Approved by	Kolja Pokovic	Technical Manager	<i>[Signature]</i>

This calibration certificate shall not be reproduced except in full without written approval of the laboratory. Issued: October 25, 2005

6. Uncertainty analysis

Error Description	Tol. (± %)	Prob. dist.	Div.	(c_i) (1g)	(c_i) (10g)	Std. unc. (± %)		(v_i)
						(1g)	(10g)	
Measurement System								
Probe Calibration	4.8	N	1	1	1	4.8	4.8	∞
Axial Isotropy	4.7	R	$\sqrt{3}$	1	1	2.7	2.7	∞
Hemispherical Isotropy	0	R	$\sqrt{3}$	1	1	0	0	∞
Boundary Effects	1.0	R	$\sqrt{3}$	1	1	0.6	0.6	∞
Linearity	4.7	R	$\sqrt{3}$	1	1	2.7	2.7	∞
System Detection Limit	1.0	R	$\sqrt{3}$	1	1	0.6	0.6	∞
Readout Electronics	1.0	N	1	1	1	1.0	1.0	∞
Response Time	0	R	$\sqrt{3}$	1	1	0	0	∞
Integration Time	0	R	$\sqrt{3}$	1	1	0	0	∞
RF Ambient Conditions	3.0	R	$\sqrt{3}$	1	1	1.7	1.7	∞
Probe Positioner	0.4	R	$\sqrt{3}$	1	1	0.2	0.2	∞
Probe Positioning	2.9	R	$\sqrt{3}$	1	1	1.7	1.7	∞
Algorithms for Max. SAR Eval.	1.0	R	$\sqrt{3}$	1	1	0.6	0.6	∞
Dipole								
Dipole Axis to Liquid Distance	2.0	R	$\sqrt{3}$	1	1	1.2	1.2	∞
Input power and SAR drift meas.	4.7	R	$\sqrt{3}$	1	1	2.7	2.7	∞
Phantom and Tissue Param.								
Phantom Uncertainty	4.0	R	$\sqrt{3}$	1	1	2.3	2.3	∞
Liquid Conductivity (target)	5.0	R.	$\sqrt{3}$	0.64	0.43	1.8	1.2	∞
Liquid Conductivity (meas.)	2.5	N	1	0.64	0.43	1.6	1.1	∞
Liquid Permittivity (target)	5.0	R	$\sqrt{3}$	0.6	0.49	1.7	1.4	∞
Liquid Permittivity (meas.)	2.5	N	1	0.6	0.49	1.5	1.2	∞
Combined Standard Uncertainty						8.4	8.1	∞
Coverage Factor for 95%		kp=2						
Expanded Uncertainty						16.8	16.2	

Dasy4 Uncertainty Budget

7. Phantom description

Schmid & Partner Engineering AG

Zeughausstrasse 43, 8004 Zurich, Switzerland, Phone +41 1 245 97 00, Fax +41 1 245 97 79

Certificate of conformity / First Article Inspection

Item	SAM Twin Phantom V4.0
Type No	QD 000 P40 CA
Series No	TP-1150 and higher
Manufacturer / Origin	Unterse Composite Hauptstr. 69 CH-8559 Frutzwilen Switzerland

Tests

The series production process used allows the limitation to test of first articles. Complete tests were made on the pre-series Type No. QD 000 P40 AA, Serial No. TP-1001 and on the series first article Type No. QD 000 P40 BA, Serial No. TP-1006. Certain parameters have been retested using further series units (called samples).

Test	Requirement	Details	Units tested
Shape	Compliance with the geometry according to the CAD model.	ITIS CAD File (*)	First article, Samples
Material thickness	Compliant with the requirements according to the standards	2mm +/- 0.2mm in specific areas	First article, Samples
Material parameters	Dielectric parameters for required frequencies	200 MHz - 3 GHz Relative permittivity < 5 Loss tangent < 0.05	Material sample TP-104-5
Material resistivity	The material has been tested to be compatible with the liquids defined in the standards	Liquid type HSL 1800 and others according to the standard.	Pre-series, First article

Standards

- [1] CENELEC EN 50361
- [2] IEEE P1528-200x draft 6.5
- [3] IEC PT 62209 draft 0.9
- (*) The ITIS CAD file is derived from [2] and is also within the tolerance requirements of the shapes of [1] and [3].

Conformity

Based on the sample tests above, we certify that this item is in compliance with the uncertainty requirements of SAR measurements specified in standard [1] and draft standards [2] and [3].

Date 28.02.2002

Signature / Stamp

F. Benschelt

**Schmid & Partner
Engineering AG**

Zeughausstrasse 43, CH-8004 Zurich
Tel. +41 1 245 97 00, Fax +41 1 245 97 79

Thomas Kappeler

The end