



**FCC 47 CFR PART 22 SUBPART H AND PART 24 SUBPART E**

**TEST REPORT**

**For**

**Mobile**

**Model: BD02A**

**Market name: ELLE N ° 2 Coleccion 2007**

**Trade Name: Alcatel**

*Issued to*

**T&A Mobile Phones**

**3/F, B2 Block, Digital Technology Yard, Gaoxin Nan Qi Road,  
Nan Shan District, Shenzhen, Guangdong, P.R.China**

*Issued by*

**COMPLIANCE CERTIFICATION SERVICES (KUNSHAN) INC.**

**10#Weiye Rd, Innovation Park Eco. & Tec. Development Zone**

**Kunshan city JiangSu, (215300) CHINA**

**TEL: 86-512-57355888**

**FAX: 86-512-57370818**



Lab. Code: 200581-0

---

*Note: This report shall not be reproduced except in full, without the written approval of Compliance Certification Services Inc. This document may be altered or revised by Compliance Certification Services Inc. personnel only, and shall be noted in the revision section of the document.*



## TABLE OF CONTENTS

<b>1. TEST RESULT CERTIFICATION.....</b>	<b>3</b>
<b>2. EUT DESCRIPTION .....</b>	<b>4</b>
<b>3. TEST METHODOLOGY .....</b>	<b>6</b>
3.1 EUT CONFIGURATION .....	6
3.2 EUT EXERCISE .....	6
3.3 GENERAL TEST PROCEDURES .....	6
3.4 DESCRIPTION OF TEST MODES .....	6
<b>4. INSTRUMENT CALIBRATION.....</b>	<b>7</b>
<b>5. FACILITIES AND ACCREDITATIONS .....</b>	<b>8</b>
5.1 FACILITIES .....	8
5.2 EQUIPMENT .....	8
5.3 LABORATORY ACCREDITATIONS AND LISTING .....	8
5.4 TABLE OF ACCREDITATIONS AND LISTINGS .....	9
<b>6. SETUP OF EQUIPMENT UNDER TEST .....</b>	<b>10</b>
6.1 SETUP CONFIGURATION OF EUT .....	10
6.2 SUPPORT EQUIPMENT.....	10
<b>7. FCC PART 22 &amp; 24 REQUIREMENTS .....</b>	<b>11</b>
7.1 PEAK POWER .....	11
7.2 ERP & EIRP MEASUREMENT .....	13
7.3 OCCUPIED BANDWIDTH MEASUREMENT .....	16
7.4 OUT OF BAND EMISSION AT ANTENNA TERMINALS .....	21
7.5 FIELD STRENGTH OF SPURIOUS RADIATION MEASUREMENT .....	31
7.6 FREQUENCY STABILITY V.S. TEMPERATURE MEASUREMENT.....	38
7.7 FREQUENCY STABILITY V.S. VOLTAGE MEASUREMENT .....	40
7.8 POWERLINE CONDUCTED EMISSIONS .....	42
<b>8. APPENDIX 1 PHOTOGRAPHS OF TEST SETUP .....</b>	<b>47</b>



# 1. TEST RESULT CERTIFICATION

**Applicant:** T&A Mobile Phones  
 3/F, B2 Block, Digital Technology Yard, Gaoxin Nan Qi Road,  
 Nan Shan District, Shenzhen, Guangdong, P.R.China

**Equipment Under Test:** Mobile

**Trade Name:** Alcatel

**Model Number:** BD02A

**Market name:** ELLE N° 2 Coleccion 2007

**Date of Test:** May 09~11, 2006

APPLICABLE STANDARDS	
STANDARD	TEST RESULT
FCC 47 CFR PART 22 SUBPART H AND PART 24 SUBPART E	No non-compliance noted

### We hereby certify that:

The above equipment was tested by Compliance Certification Services Inc. The test data, data evaluation, test procedures, and equipment configurations shown in this report were made in accordance with the procedures given in ANSI/TIA/EIA-603-A-2001 and the energy emitted by the sample EUT tested as described in this report is in compliance with conducted and radiated emission limits of FCC Rule FCC PART 22 Subpart H and PART 24 Subpart E.

The test results of this report relate only to the tested sample identified in this report.

Approved by:

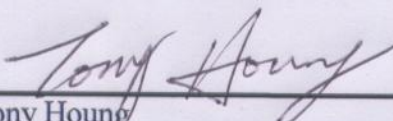
  
 \_\_\_\_\_  
 Tony Houng  
 General Manager of Kunshan Laboratory  
 Compliance Certification Services Inc.

Reviewed by:

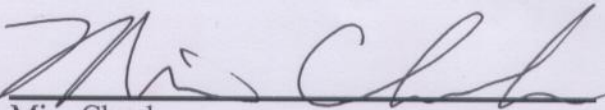
  
 \_\_\_\_\_  
 Miro Chueh  
 Section Manager of Kunshan Laboratory  
 Compliance Certification Services Inc.



## 2. EUT DESCRIPTION

<b>Product</b>	Mobile
<b>Trade Name</b>	Alcatel
<b>Model Number</b>	BD02A
<b>Market name</b>	ELLE N ° 2 Coleccion 2007
<b>Model Discrepancy</b>	N/A
<b>Power Supply</b>	<ol style="list-style-type: none"> <li>1. AC to DC charger Trade Name :Alcatel Model Number :3DS09371AGAA Input: AC100-127V, 50/60Hz, 0.15 A Output: DC4.5V,350mA DC Power Cord: DC Power Cable 2m Non-shielding, Non-detachable, without Core Manufactures: Astec</li> <li>2. AC to DC charger Trade Name :Alcatel Model Number :3DS09371AGAA Input: AC100-127V, 50/60Hz, 0.3 A Output: DC4.5V,350mA DC Power Cord: DC Power Cable 2.05m Non-shielding, Non-detachable, without Core Manufactures: Leader</li> <li>3. AC to DC charger Trade Name :Alcatel Model Number :3DS09371AAAA Input: AC200-240V, 50/60Hz, 0.3 A Output: DC4.5V,350mA DC Power Cord: DC Power Cable 2m Non-shielding, Non-detachable, without Core Manufactures: Astec</li> <li>4. AC to DC charger Trade Name :Alcatel Model Number : 3DS09371AAAA Input: AC200-240V, 50/60Hz, 0.15 A Output: DC4.5V,350mA DC Power Cord: DC Power Cable 2.06m Non-shielding, Non-detachable, without Core Manufactures: Leader</li> <li>5. DC to DC charger Trade Name :Alcatel Model Number :3DS07848AAAA Input: DC12/24V, Output: DC4.5V DC Power Cord: DC Power Cable 2.64m Non-shielding,</li> </ol>



	Non-detachable, without Core Manufactures: Primax 6. Battery: Alcatel / 3DS11080AAAA Lithium-Ion 3.7V/ 600mAh
<b>Frequency Range</b>	TX: 824 ~ 849 MHz / 1850 ~ 1910 MHz RX: 869 ~ 894 MHz / 1930 ~ 1990 MHz
<b>Transmit Power</b>	31.82 dBm GSM 850: 31.82dBm GSM 1900: 28.72dBm
<b>Cellular Phone Protocol</b>	GSM (PCS)
<b>Type of Emission</b>	243KGXW
<b>Antenna Type</b>	Inner Antenna

**Remark:** This submittal(s) (test report) is intended for FCC ID: RAD042 filing to comply with Part 22 and Part 24 of the FCC 47 CFR Rules.



### 3. TEST METHODOLOGY

Both conducted and radiated testing were performed according to the procedures document on chapter 13 of ANSI C63.4 and FCC CFR 47, 2.1046, 2.1047, 2.1049, 2.1051, 2.1053, 2.1055 and 2.1057.

#### EUT CONFIGURATION

The EUT configuration for testing is installed on RF field strength measurement to meet the Commissions requirement and operating in a manner that intends to maximize its emission characteristics in a continuous normal application.

#### EUT EXERCISE

The EUT was operated in the engineering mode to fix the TX frequency that was for the purpose of the measurements.

#### GENERAL TEST PROCEDURES

##### Conducted Emissions

The EUT is placed on the turntable, which is 0.8 m above ground plane. According to the requirements in Section 13.1.4.1 of ANSI C63.4. Conducted emissions from the EUT measured in the frequency range between 0.15 MHz and 30MHz using CISPR Quasi-peak and average detector modes.

##### Radiated Emissions

The EUT is placed on a turn table, which is 0.8 m above ground plane. The turntable shall rotate 360 degrees to determine the position of maximum emission level. EUT is set 3m away from the receiving antenna, which varied from 1m to 4m to find out the highest emission. And also, each emission was to be maximized by changing the polarization of receiving antenna both horizontal and vertical. In order to find out the maximum emissions, exploratory radiated emission measurements were made according to the requirements in Section 13.1.4.1 of ANSI C63.4.

#### DESCRIPTION OF TEST MODES

The EUT (model: SVLE6) had been tested under operating condition.

EUT staying in continuous transmitting mode was programmed. Channel Low, Mid and High were chosen for full testing.

After verification, all tests were carried out with the worst case test modes as shown below except radiated spurious emission below 1GHz, which worst case was in normal link mode only.

The field strength of spurious emission was measured in the following position: EUT stand-up position (Z axis), lie-down position (X, Y axis). The worst emission was found in stand-up position (Z axis) and the worst case was recorded.



#### **4. INSTRUMENT CALIBRATION**

The measuring equipment, which was utilized in performing the tests documented herein, has been calibrated in accordance with the manufacturer's recommendations for utilizing calibration equipment, which is traceable to recognized national standards.





## **5. FACILITIES AND ACCREDITATIONS**

### **FACILITIES**

All measurement facilities used to collect the measurement data are located at CCS China Kunshan Lab at 10#, Weiye Rd, Innovation Park Eco. & Tec. Development Zone Kunshan city JiangSu, (215300)CHINA.

The sites are constructed in conformance with the requirements of ANSI C63.7, ANSI C63.4 and CISPR Publication 22.

### **EQUIPMENT**

Radiated emissions are measured with one or more of the following types of linearly polarized antennas: tuned dipole, biconical, log periodic, bi-log, and/or ridged waveguide, horn. Spectrum analyzers with pre-selectors and quasi-peak detectors are used to perform radiated measurements.

Conducted emissions are measured with Line Impedance Stabilization Networks and EMI Test Receivers.

Calibrated wideband preamplifiers, coaxial cables, and coaxial attenuators are also used for making measurements.





All receiving equipment conforms to CISPR Publication 16-1, "Radio Interference Measuring Apparatus and Measurement Methods."

### **LABORATORY ACCREDITATIONS AND LISTING**

The test facilities used to perform radiated and conducted emissions tests are accredited by National Voluntary Laboratory Accreditation Program for the specific scope of accreditation under Lab Code: 200581-0 to perform Electromagnetic Interference tests according to FCC PART 15 AND CISPR 22 requirements. No part of this report may be used to claim or imply product endorsement by NVLAP or any agency of the US Government. In addition, the test facilities are listed with Federal Communications Commission (Registration no: 93105 and 90471).



**TABLE OF ACCREDITATIONS AND LISTINGS**

Country	Agency	Scope of Accreditation	Logo
USA	NVLAP	EN 55022, EN 61000-3-2, EN 61000-3-3, EN550024, EN 61000-4-2, EN 61000-4-3, EN61000-4-4, EN 61000-4-5, EN 61000-4-6, IEC 61000-4-8, EN 61000-4-11 ANSI C63.4, CISPR16-1, IEC61000-3-2, IEC61000-3-3, IEC 61000-4-2, IEC 61000-4-3, IEC 61000-4-4, IEC 61000-4-5, IEC 61000-4-6, IEC 61000-4-8, IEC 61000-4-11	 Lab. Code: 200581-0
USA	FCC	3/10 meter Sites to perform FCC Part 15/18 measurements	 93105, 90471
Japan	VCCI	3/10 meter Sites and conducted test sites to perform radiated/conducted measurements	 R-1600 C-1707
Norway	NEMKO	EN61000-6-1/2/3/4, EN 50082-1/2, IEC 61000-6-1/2/3/4, EN 50091-2, EN 55011, EN 55022, EN 55024, EN 61000-3-2/3, EN 61000-11, IEC 61000-4-2/3/4/5/6/8/11, CISPR16-1/2/3/4	 ELA 105

*\* No part of this report may be used to claim or imply product endorsement by NVLAP or any agency of the US Government.*



## 6. SETUP OF EQUIPMENT UNDER TEST

### SETUP CONFIGURATION OF EUT

See test photographs attached in Appendix 1 for the actual connections between EUT and support equipment.

### SUPPORT EQUIPMENT

No.	Device Type	Brand	Model	FCC ID	Series No.	Data Cable	Power Cord
1	N/A						

**Remark:**

- 1. All the equipment/cables were placed in the worst-case configuration to maximize the emission during the test.*
- 2. Grounding was established in accordance with the manufacturer's requirements and conditions for the intended use.*



## 7. FCC PART 22 & 24 REQUIREMENTS

### PEAK POWER

#### LIMIT

According to FCC §2.1046.

#### MEASUREMENT EQUIPMENT USED

Name of Equipment	Manufacturer	Model	Serial Number	Calibration Due
Peak and Avg Power Sensor	Agilent	E9327A	US40441788	07/30/2006
EPM-P Series Power Meter	Agilent	E4416A	QB41292714	07/30/2006
Spectrum Analyzer	Agilent	E4446A	MY44020154	08/16/2006
Wireless communication test set	Agilent	8960	QB44051695	10/06/2006

*Remark: Each piece of equipment is scheduled for calibration once a year.*

#### Test Configuration

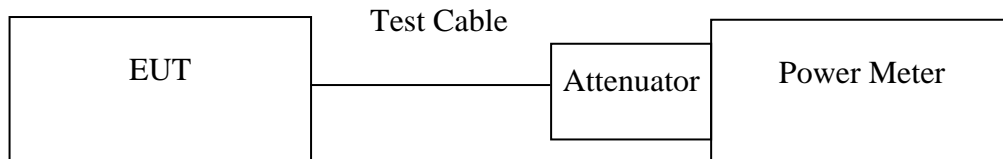

*Remark: Measurement setup for testing on Antenna connector*

#### TEST PROCEDURE

The transmitter output was connected to a calibrated attenuator, the other end of which was connected to a power meter. Transmitter output was read off the power meter in dBm. The power output at the transmitter antenna port was determined by adding the value of the attenuator to the power meter reading.



## **TEST RESULTS**

*No non-compliance noted.*

### **Test Data**

Test Mode	CH	Frequency (MHz)	Power Meter Reading (dBm)	Factor (dB)	Peak Power (dBm)
GSM 850	128	824.20	5.32	26.50	31.82
	190	836.60	5.15		31.65
	251	848.80	4.80		31.30

*Remark: The value of factor includes both the loss of cable and external attenuator*

Test Mode	CH	Frequency (MHz)	Power Meter Reading (dBm)	Factor (dB)	Peak Power (dBm)
GSM 1900	512	1850.20	4.22	24.50	28.72
	661	1880.00	4.16		28.66
	810	1910.00	3.71		28.21

*Remark: The value of factor includes both the loss of cable and external attenuator*

## ERP & EIRP MEASUREMENT

### LIMIT

According to FCC §2.1046

FCC 22.913(b): The Effective Radiated Power (ERP) of mobile transmitters must not exceed 7 Watts.

FCC 24.232(b): The equivalent Isotropic Radiated Power (EIRP) must not exceed 2 Watts.

### MEASUREMENT EQUIPMENT USED

977 Chamber (3m)				
Name of Equipment	Manufacturer	Model	Serial Number	Calibration Due
Spectrum Analyzer	Agilent	E4446A	MY44020154	08/16/2006
EMI Test Receiver	R&S	ESPI3	101026	11/11/2006
Pre-Amplifier	MINI-circuits	ZFL-1000VH2	d041703	12/13/2006
Pre-Amplifier	Miteq	NSP4000-NF	870731	01/28/2007
Bilog Antenna	Sunol	JB1	A110204-2	11/22/2006
Horn-antenna	SCHWARZBECK	BBHA9120D	D:266	02/01/2007
PSG Analog Signal Generator	Agilent	E8257C	MY43321570	12/19/2006
Wireless communication test set	Agilent	8960	QB44051695	10/06/2006
Turn Table	CT	CT123	4165	N.C.R
Antenna Tower	CT	CTERG23	3256	N.C.R
Controller	CT	CT100	95637	N.C.R
Site NSA	CCS	N/A	N/A	04/06/2007

*Remark: Each piece of equipment is scheduled for calibration once a year.*

### TEST CONFIGURATION

**Below 1 GHz**

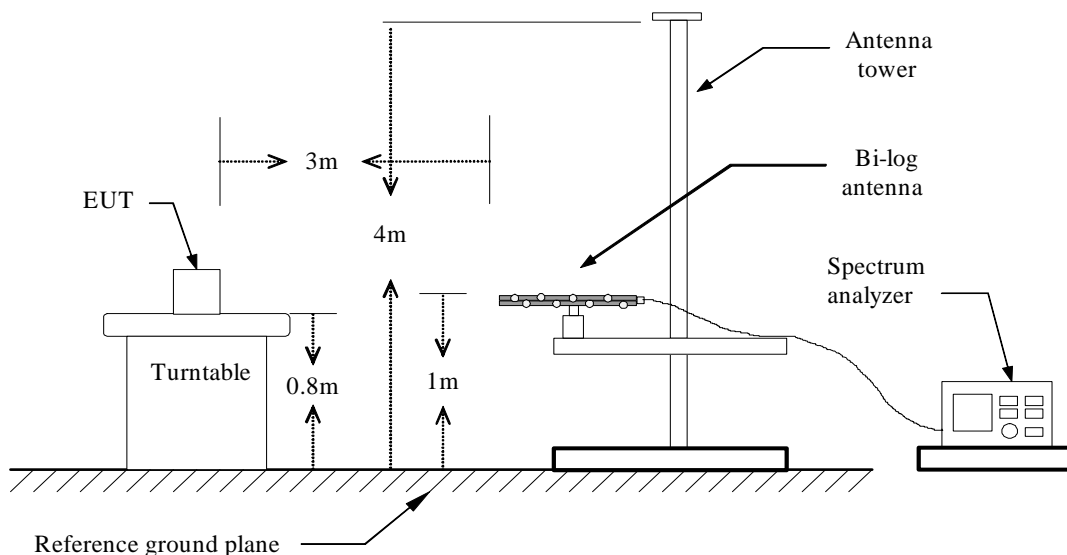

**Above 1 GHz**

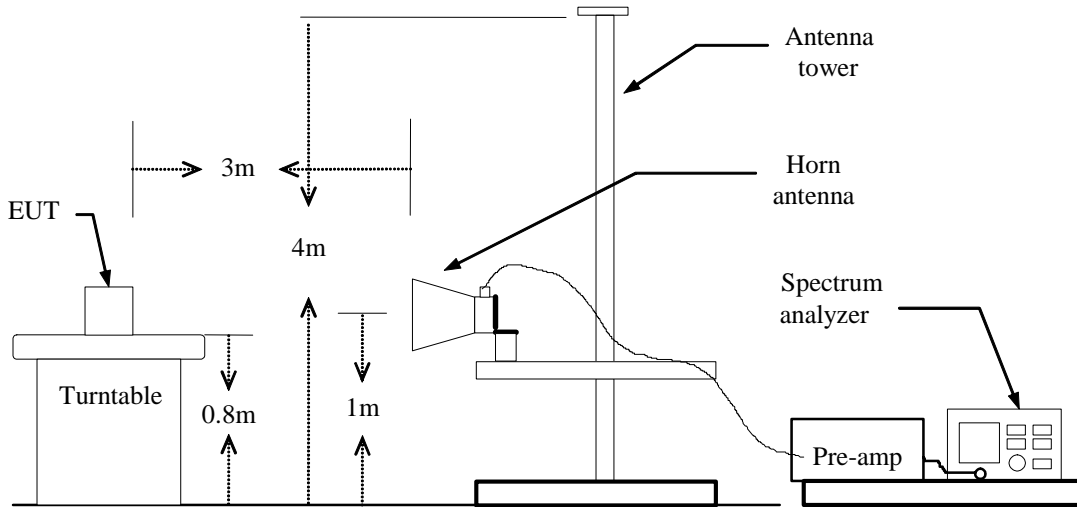

**For Substituted Method Test Set-UP**

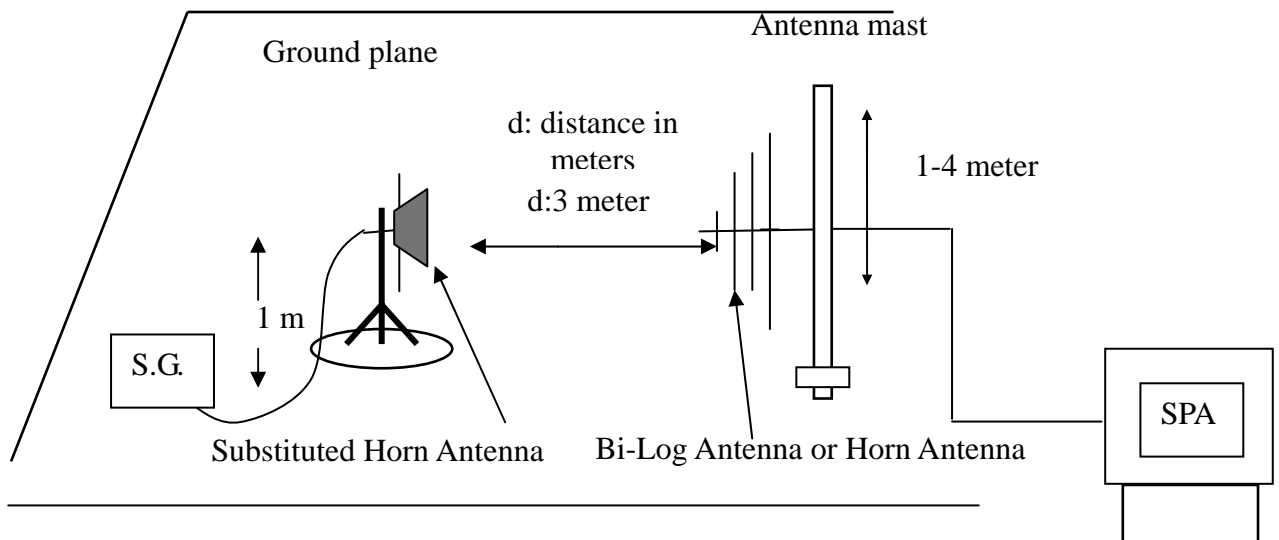

**TEST PROCEDURE**

The EUT was placed on an non-conductive turntable using a non-conductive support. The radiated emission at the fundamental frequency was measured at 3 m with a test antenna and EMI spectrum analyzer.

During the measurement of the EUT, the resolution bandwidth was set to 3MHz and the average bandwidth was set to 3MHz. The highest emission was recorded with the rotation of the turntable and the lowering of the test antenna. The reading was recorded and the field strength (E in dBuV/m) was calculated.

ERP in frequency band 824-849MHz, and EIRP in frequency band 1851.25 –1910MHz were measured using a substitution method. The EUT was replaced by half-wave dipole (824-849MHz) or horn antenna (1851.25-1910MHz) connected to a signal generator. The spectrum analyzer reading was recorded and ERP/EIRP was calculated as follows:

$$ERP = \text{S.G. output (dBm)} + \text{Antenna Gain (dBd)} - \text{Cable (dB)}$$

$$EIRP = \text{S.G. output (dBm)} + \text{Antenna Gain (dBi)} - \text{Cable (dB)}$$



**TEST RESULTS**

No non-compliance noted.

**GSM 850 Test Data**

EUT Pol.	Channel	Frequency (MHz)	Reading level (dBuV)	Antenna Pol.	S.G. (dBm)	Cable loss (dB)	Ant.Gain (dBi)	Emission level (dBm)	Limit (dBm)	Margin (dB)
Z	128	824.20	129.95	V	28.05	2.87	6.20	31.38	38.5	-7.12
		824.20	118.83	H	23.11	2.87	6.20	26.44	38.5	-12.06
	190	836.60	129.17	V	27.65	2.88	6.40	31.17	38.5	-7.33
		836.60	117.88	H	23.32	2.88	6.40	26.84	38.5	-11.66
	251	848.80	127.89	V	27.16	2.94	6.50	30.72	38.5	-7.78
		848.80	117.15	H	21.35	2.94	6.50	24.91	38.5	-13.59

**GSM 1900 Test Data**

EUT Pol.	Channel	Frequency (MHz)	Reading level (dBuV)	Antenna Pol.	S.G. (dBm)	Cable loss (dB)	Ant.Gain (dBi)	Emission level (dBm)	Limit (dBm)	Margin (dB)
Z	512	1850.20	121.34	V	24.02	4.31	8.45	28.16	33	-4.84
		1850.20	118.66	H	19.67	4.31	8.45	23.81	33	-9.19
	661	1880.00	119.82	V	24.18	4.53	8.48	28.13	33	-4.87
		1880.00	117.47	H	20.06	4.53	8.48	24.01	33	-8.99
	810	1909.80	118.76	V	23.72	4.55	8.52	27.69	33	-5.31
		1909.80	116.87	H	19.38	4.55	8.52	23.35	33	-9.65





## OCCUPIED BANDWIDTH MEASUREMENT

### LIMIT

According to §FCC 2.1049.

### MEASUREMENT EQUIPMENT USED

Name of Equipment	Manufacturer	Model	Serial Number	Calibration Due
Spectrum Analyzer	Agilent	E4446A	MY44020154	08/16/2006
Wireless communication test set	Agilent	8960	QB44051695	10/06/2006

*Remark: Each piece of equipment is scheduled for calibration once a year.*

### Test Configuration

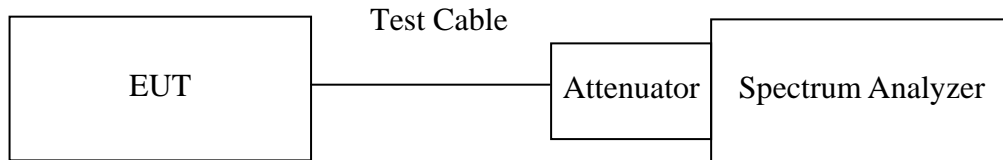

*Remark: Measurement setup for testing on Antenna connector*

### TEST PROCEDURE

The EUT's output RF connector was connected with a short cable to the spectrum analyzer, RBW was set to about 1% of emission BW, VBW is set to 3 times the RBW, -26dBc display line was placed on the screen (or 99% bandwidth), the occupied bandwidth is the delta frequency between the two points where the display line intersects the signal trace.

The spectrum analyzer is set to: RBW = 3 kHz, VBW = 10 kHz, Span = 1 MHz, Sweep = auto



## **TEST RESULTS**

*No non-compliance noted*

### **Test Data**

<b>Test Mode</b>	<b>CH</b>	<b>Frequency (MHz)</b>	<b>Bandwidth (kHz)</b>
GSM 850	128	824.20	240.48
	190	836.60	242.09
	251	848.80	240.81

<b>Test Mode</b>	<b>CH</b>	<b>Frequency (MHz)</b>	<b>Bandwidth (kHz)</b>
GSM 1900	512	1850.20	242.72
	661	1880.00	241.10
	810	1909.80	241.68



**Test Plot**

**GSM 850 (CH Low)**

Agilent 22:16:37 May 9, 2006

<div style="border: 1px solid black; padding: 2px;"> <p style="text-align: center;"><b>Ch Freq</b> 824.2 MHz <span style="float: right;"><b>Trig</b> Free</span></p> <p>Occupied Bandwidth <span style="float: right;">[ ]</span></p> </div> <div style="border: 1px solid black; padding: 2px; margin-top: 5px;"> <p>Ref 40 dBm      #Atten 30 dB</p> <p>#Peak Log 10 dB/ Offst 26.5 dB</p> <p style="text-align: center;">Center 824.200 MHz <span style="float: right;">Span 1 MHz</span></p> <p>#Res BW 3 kHz      #VBW 10 kHz      Sweep 105.4 ms (601 pts)</p> </div> <div style="border: 2px solid green; padding: 5px; margin-top: 5px;"> <p><b>Occupied Bandwidth</b> <span style="float: right;"><b>Occ BW % Pwr</b> 99.00 %</span></p> <p style="text-align: center; font-size: 1.2em;"><b>240.4805 kHz</b> <span style="float: right;"><b>x dB</b> -26.00 dB</span></p> <p><b>Transmit Freq Error</b> -298.280 Hz</p> <p><b>x dB Bandwidth</b> 306.353 kHz</p> </div>	<table border="1" style="width: 100%; border-collapse: collapse;"> <tr><td style="text-align: center;"><b>Measure</b></td></tr> <tr><td style="text-align: center;">Meas Off</td></tr> <tr><td style="text-align: center;">Channel Power</td></tr> <tr><td style="text-align: center;">Occupied BW</td></tr> <tr><td style="text-align: center;">ACP</td></tr> <tr><td style="text-align: center;">Multi Carrier Power</td></tr> <tr><td style="text-align: center;">Power Stat CCDF</td></tr> <tr><td style="text-align: center;">More 1 of 2</td></tr> </table>	<b>Measure</b>	Meas Off	Channel Power	Occupied BW	ACP	Multi Carrier Power	Power Stat CCDF	More 1 of 2
<b>Measure</b>									
Meas Off									
Channel Power									
Occupied BW									
ACP									
Multi Carrier Power									
Power Stat CCDF									
More 1 of 2									
<p style="color: green;">Copyright 2000-2003 Agilent Technologies</p>									

**GSM 850 (CH Mid)**

Agilent 22:18:15 May 9, 2006

<div style="border: 1px solid black; padding: 2px;"> <p style="text-align: center;"><b>Ch Freq</b> 836.6 MHz <span style="float: right;"><b>Trig</b> Free</span></p> <p>Occupied Bandwidth <span style="float: right;">[ ]</span></p> </div> <div style="border: 1px solid black; padding: 2px; margin-top: 5px;"> <p>Ref 40 dBm      #Atten 30 dB</p> <p>#Peak Log 10 dB/ Offst 26.5 dB</p> <p style="text-align: center;">Center 836.600 MHz <span style="float: right;">Span 1 MHz</span></p> <p>#Res BW 3 kHz      #VBW 10 kHz      Sweep 105.4 ms (601 pts)</p> </div> <div style="border: 2px solid green; padding: 5px; margin-top: 5px;"> <p><b>Occupied Bandwidth</b> <span style="float: right;"><b>Occ BW % Pwr</b> 99.00 %</span></p> <p style="text-align: center; font-size: 1.2em;"><b>242.0873 kHz</b> <span style="float: right;"><b>x dB</b> -26.00 dB</span></p> <p><b>Transmit Freq Error</b> 70.128 Hz</p> <p><b>x dB Bandwidth</b> 312.649 kHz</p> </div>	<table border="1" style="width: 100%; border-collapse: collapse;"> <tr><td style="text-align: center;"><b>Measure</b></td></tr> <tr><td style="text-align: center;">Meas Off</td></tr> <tr><td style="text-align: center;">Channel Power</td></tr> <tr><td style="text-align: center;">Occupied BW</td></tr> <tr><td style="text-align: center;">ACP</td></tr> <tr><td style="text-align: center;">Multi Carrier Power</td></tr> <tr><td style="text-align: center;">Power Stat CCDF</td></tr> <tr><td style="text-align: center;">More 1 of 2</td></tr> </table>	<b>Measure</b>	Meas Off	Channel Power	Occupied BW	ACP	Multi Carrier Power	Power Stat CCDF	More 1 of 2
<b>Measure</b>									
Meas Off									
Channel Power									
Occupied BW									
ACP									
Multi Carrier Power									
Power Stat CCDF									
More 1 of 2									
<p style="color: green;">File Operation Status, A:\SCREN594.GIF file saved</p>									



### GSM 850 (CH High)

Agilent 22:18:52 May 9, 2006

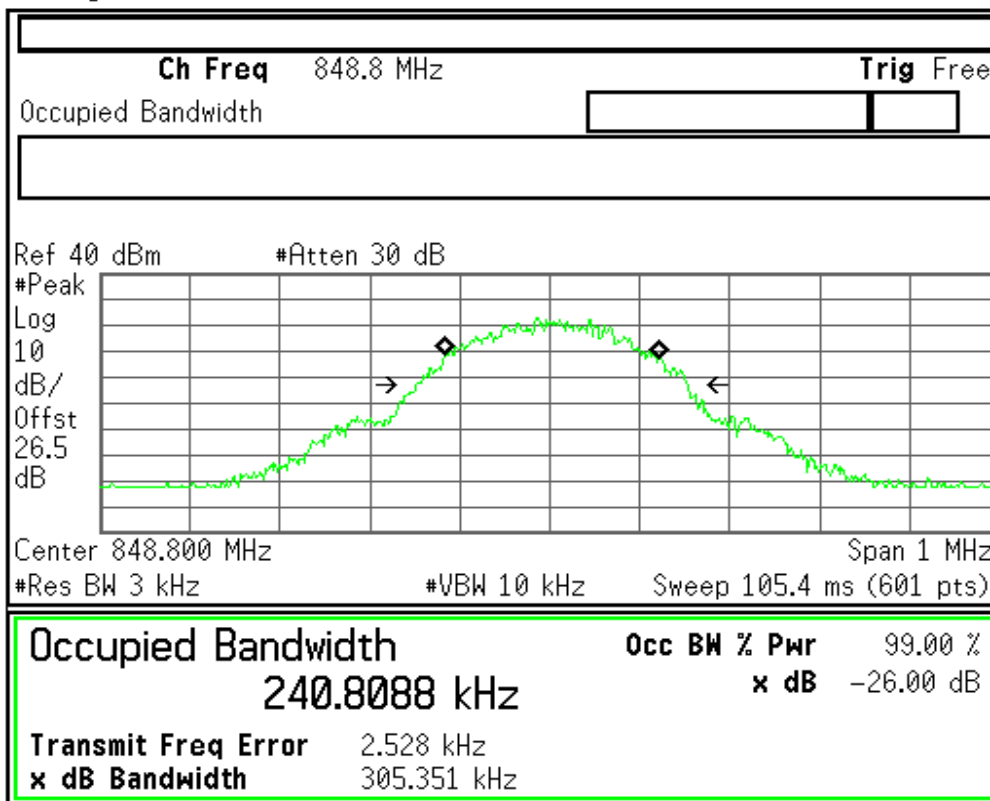

<b>Measure</b>
Meas Off
Channel Power
Occupied BW
ACP
Multi Carrier Power
Power Stat CCDF
More 1 of 2

Copyright 2000-2003 Agilent Technologies

### GSM 1900 (CH Low)

Agilent 22:23:19 May 9, 2006

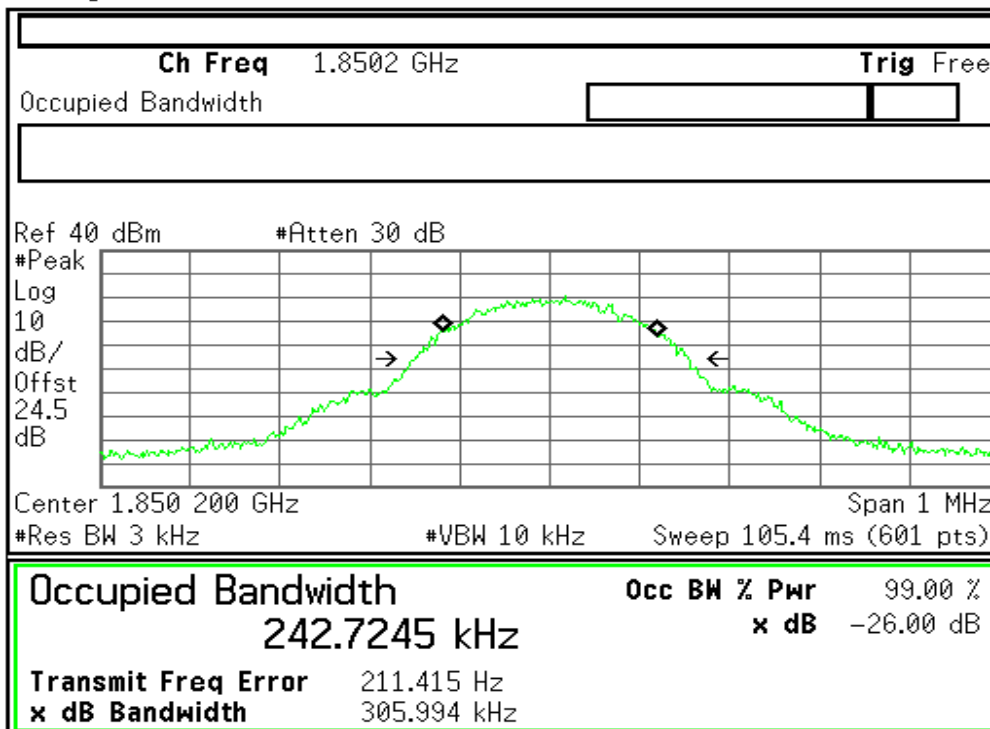

<b>Measure</b>
Meas Off
Channel Power
Occupied BW
ACP
Multi Carrier Power
Power Stat CCDF
More 1 of 2

Copyright 2000-2003 Agilent Technologies



**GSM 1900 (CH Mid)**

Agilent 22:24:17 May 9, 2006

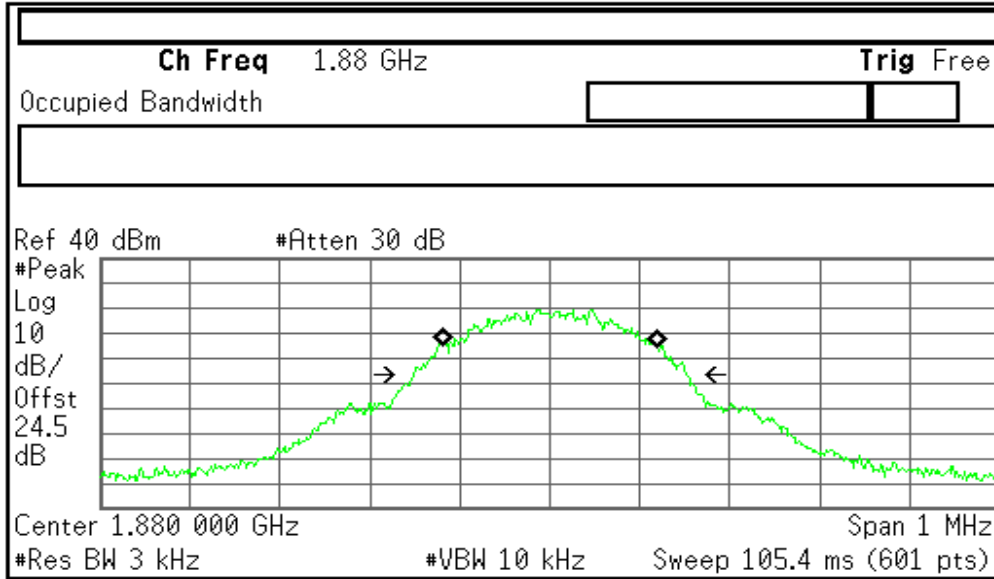

<b>Occupied Bandwidth</b>	<b>Occ BW % Pwr</b>	99.00 %
<b>241.0974 kHz</b>	<b>x dB</b>	-26.00 dB
<b>Transmit Freq Error</b>		-919.649 Hz
<b>x dB Bandwidth</b>		306.828 kHz

File Operation Status, A:\SCREN599.GIF file saved

Measure
Meas Off
Channel Power
Occupied BW
ACP
Multi Carrier Power
Power Stat CCDF
More 1 of 2

**GSM 1900 (CH High)**

Agilent 22:25:00 May 9, 2006

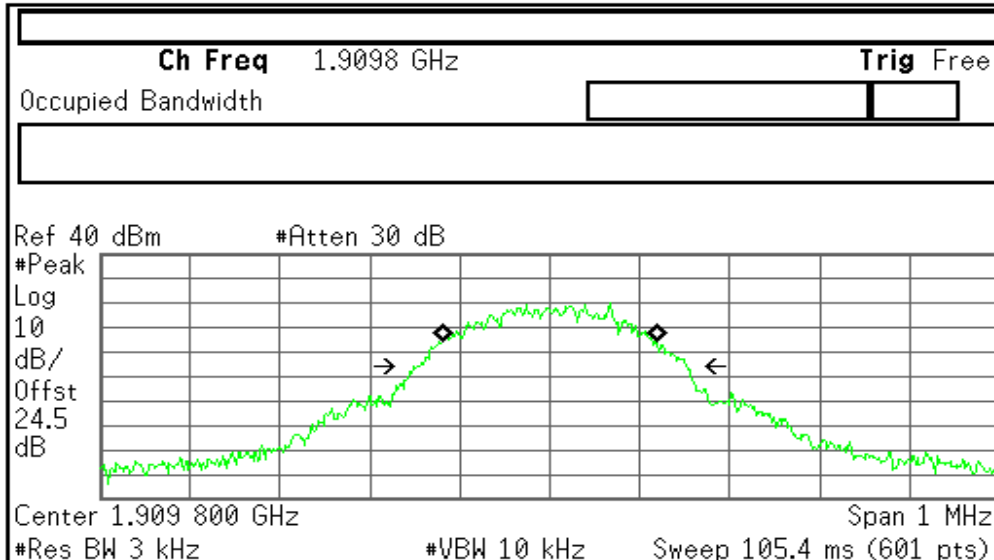

<b>Occupied Bandwidth</b>	<b>Occ BW % Pwr</b>	99.00 %
<b>241.6832 kHz</b>	<b>x dB</b>	-26.00 dB
<b>Transmit Freq Error</b>		-975.863 Hz
<b>x dB Bandwidth</b>		308.187 kHz

Copyright 2000-2003 Agilent Technologies

Measure
Meas Off
Channel Power
Occupied BW
ACP
Multi Carrier Power
Power Stat CCDF
More 1 of 2



## OUT OF BAND EMISSION AT ANTENNA TERMINALS

### LIMIT

According to FCC §2.1051, FCC §2.2917(f), FCC §22.917(f), FCC §24.238(a).

**Out of Band Emissions:** The mean power of emission must be attenuated below the mean power of the non-modulated carrier (P) on any frequency twice or more than twice the fundamental frequency by at least  $43 + 10 \log P$  dB.

**Mobile Emissions in Base Frequency Range:** The mean power of any emissions appearing in the base station frequency range from cellular mobile transmitters operated must be attenuated to a level not exceed  $-80$  dBm at the transmit antenna connector.

**Band Edge Requirements:** In the 1MHz bands immediately outside and adjacent to the frequency block, a resolution bandwidth of at least 1% of the emission bandwidth of the fundamental emission of the transmitter may be employed to measure the Out of band Emission

### MEASUREMENT EQUIPMENT USED

Name of Equipment	Manufacturer	Model	Serial Number	Calibration Due
Spectrum Analyzer	Agilent	E4446A	MY44020154	08/16/2006
Wireless communication test set	Agilent	8960	QB44051695	10/06/2006

*Remark: Each piece of equipment is scheduled for calibration once a year.*

### TEST CONFIGURATION

Out of band emission at antenna terminals:

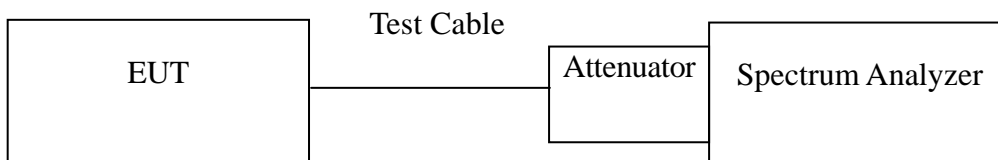

### TEST PROCEDURE

The RF output of the transceiver was connected to a spectrum analyzer through appropriate attenuation. The resolution bandwidth of the spectrum analyzer was set at 1MHz, sufficient scans were taken to show the out of band Emissions if any up to 10th harmonic.

For the out of band: Set the RBW, VBW = 1MHz, Start=30MHz, Stop= 10 th harmonic. Limit = -13dBm

Band Edge Requirements (824 MHz and 849 MHz /1850MHz and 1910MHz): In the 1 MHz bands immediately outside and adjacent to the frequency block, a resolution bandwidth of at least 1 percent of the emission bandwidth of the fundamental emission of the transmitter may be employed to measure the out of band Emissions. Limit, -13dBm.

For the Band Edge: The spectrum analyzer is set to: RBW = 3 kHz, VBW = 10 kHz, Span = 1 MHz, Sweep = auto



### TEST RESULTS

No non-compliance noted.

#### Test Data

Mode	CH	Location	Description
GSM 850	128	Figure 7-1	Conducted spurious emissions, 30MHz - 2.5GHz
		Figure 7-2	Conducted spurious emissions, 2.5GHz - 20GHz
	190	Figure 7-3	Conducted spurious emissions, 30MHz - 2.5GHz
		Figure 7-4	Conducted spurious emissions, 2.5GHz - 20GHz
	251	Figure 7-5	Conducted spurious emissions, 30MHz - 2.5GHz
		Figure 7-6	Conducted spurious emissions, 2.5GHz - 20GHz

Mode	CH	Location	Description
GSM 1900	512	Figure 8-1	Conducted spurious emissions, 30MHz - 2.5GHz
		Figure 8-2	Conducted spurious emissions, 2.5GHz - 20GHz
	661	Figure 8-3	Conducted spurious emissions, 30MHz - 2.5GHz
		Figure 8-4	Conducted spurious emissions, 2.5GHz - 20GHz
	810	Figure 8-5	Conducted spurious emissions, 30MHz - 2.5GHz
		Figure 8-6	Conducted spurious emissions, 2.5GHz - 20GHz

Mode	CH	Location	Description
GSM 850	128	Figure 9-1	Band Edge emissions
	251	Figure 9-2	Band Edge emissions

Mode	CH	Location	Description
GSM 1900	512	Figure 10-1	Band Edge emissions
	810	Figure 10-2	Band Edge emissions





**Test Plot**

**GSM 850**

Figure 7-1: Out of Band emission at antenna terminals – GSM CH Low

Agilent 22:42:36 May 9, 2006

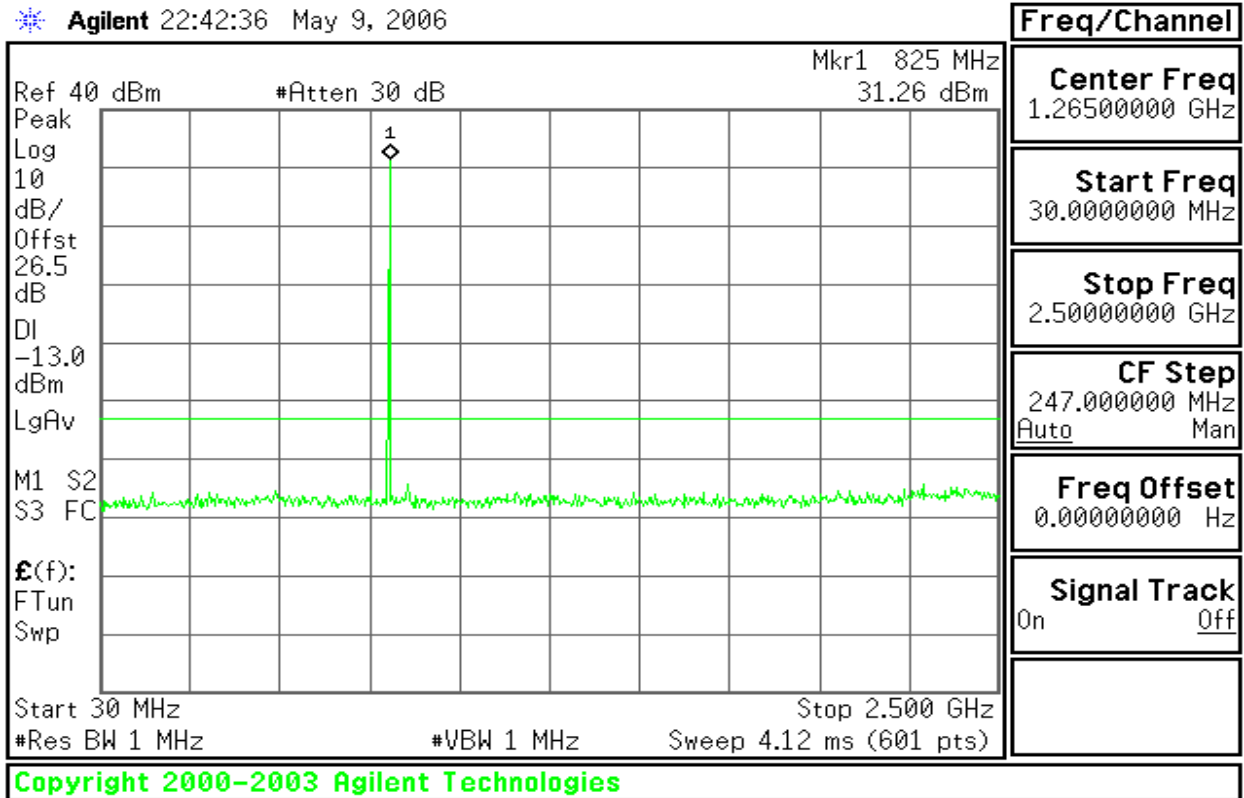

Figure 7-2: Out of Band emission at antenna terminals – GSM CH Low

Agilent 22:43:05 May 9, 2006

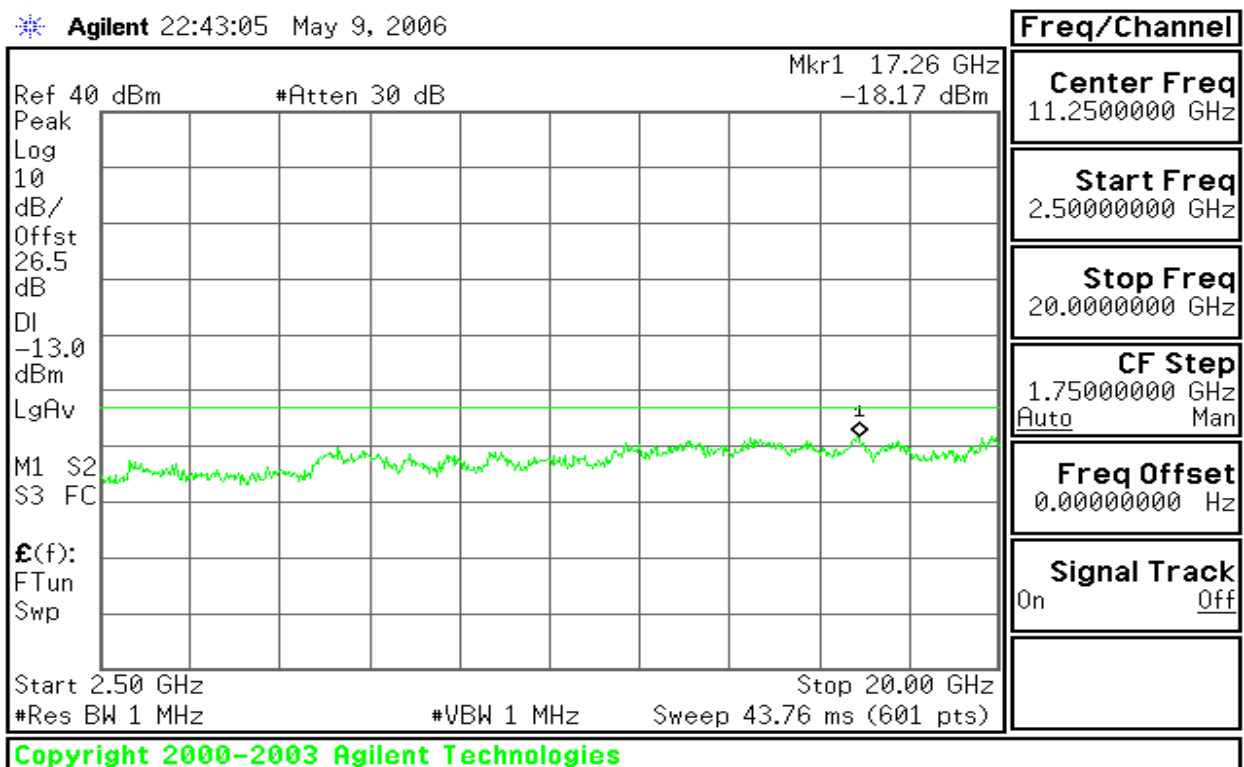

Figure 7-3: Out of Band emission at antenna terminals – GSM CH Mid

Agilent 22:43:56 May 9, 2006

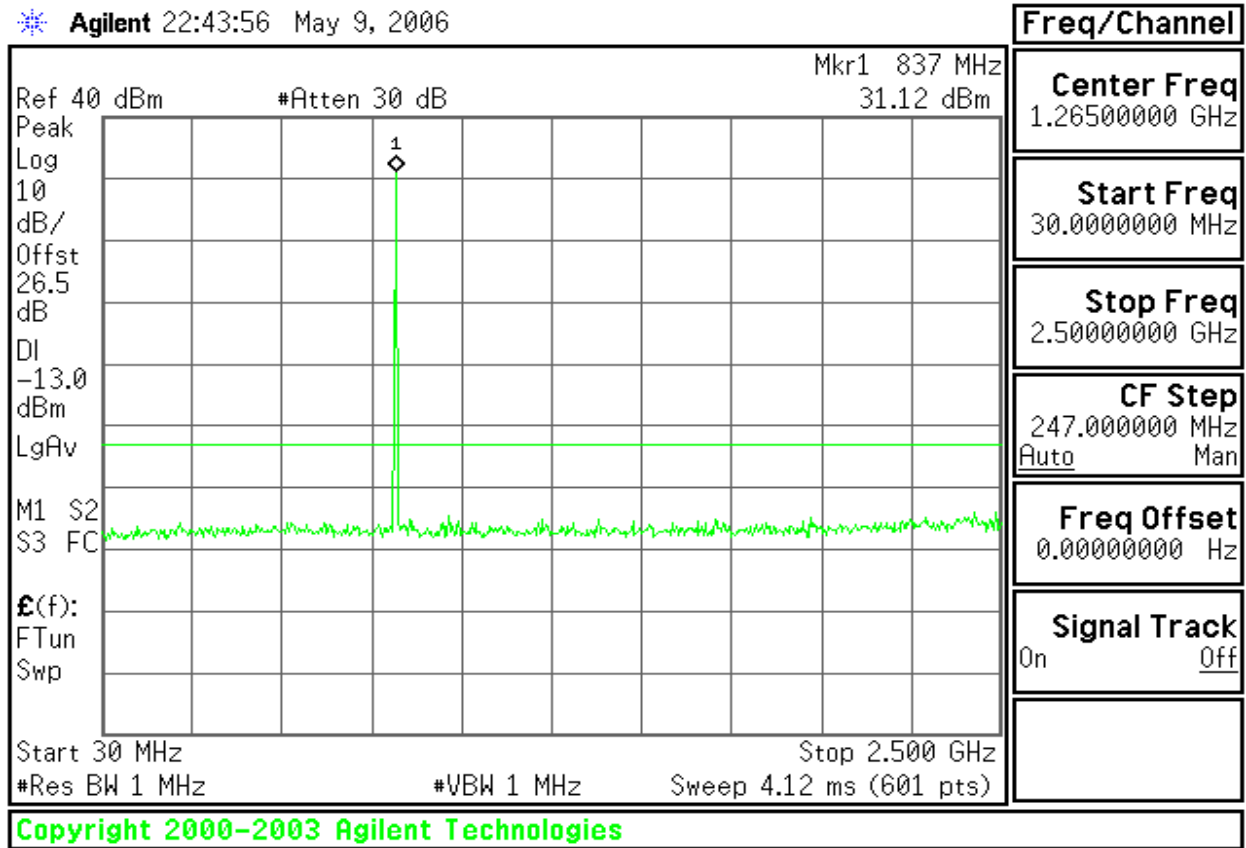

Figure 7-4: Out of Band emission at antenna terminals – GSM CH Mid

Agilent 22:43:31 May 9, 2006

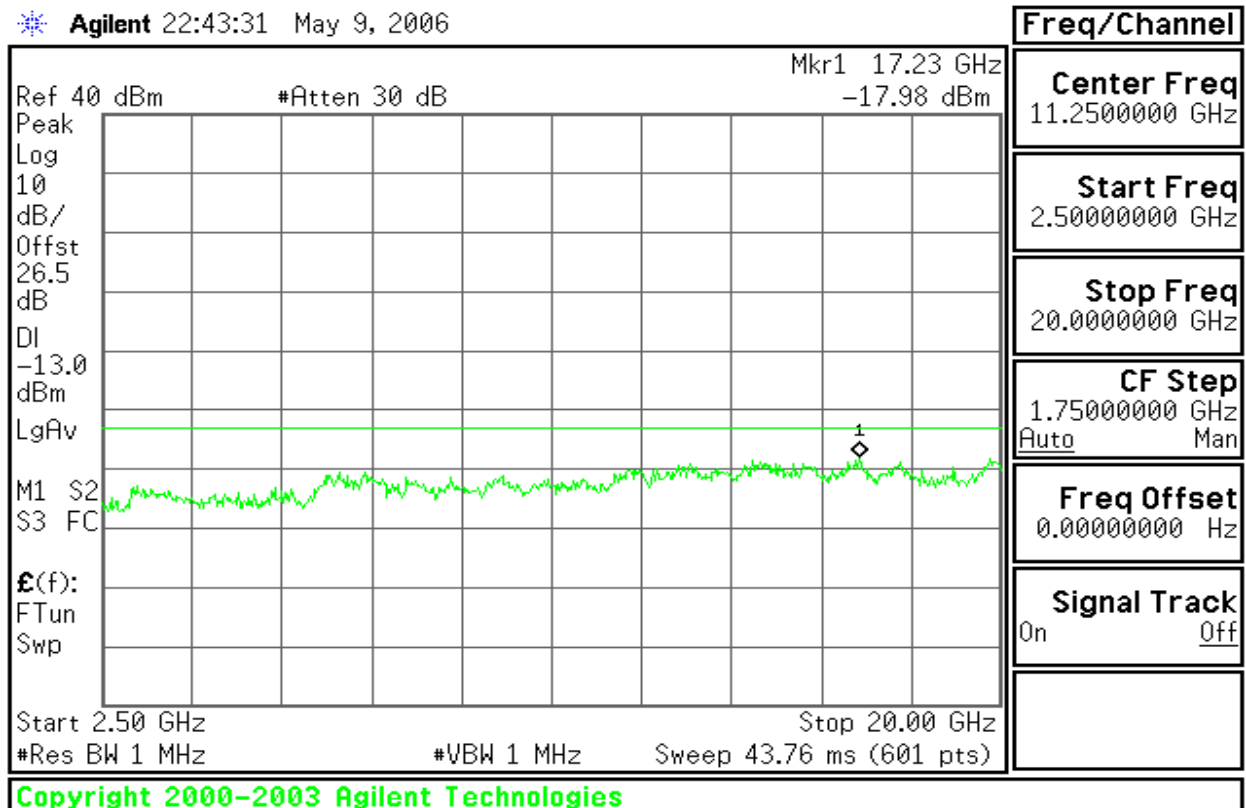



Figure 7-5: Out of Band emission at antenna terminals – GSM CH High

Agilent 22:44:14 May 9, 2006

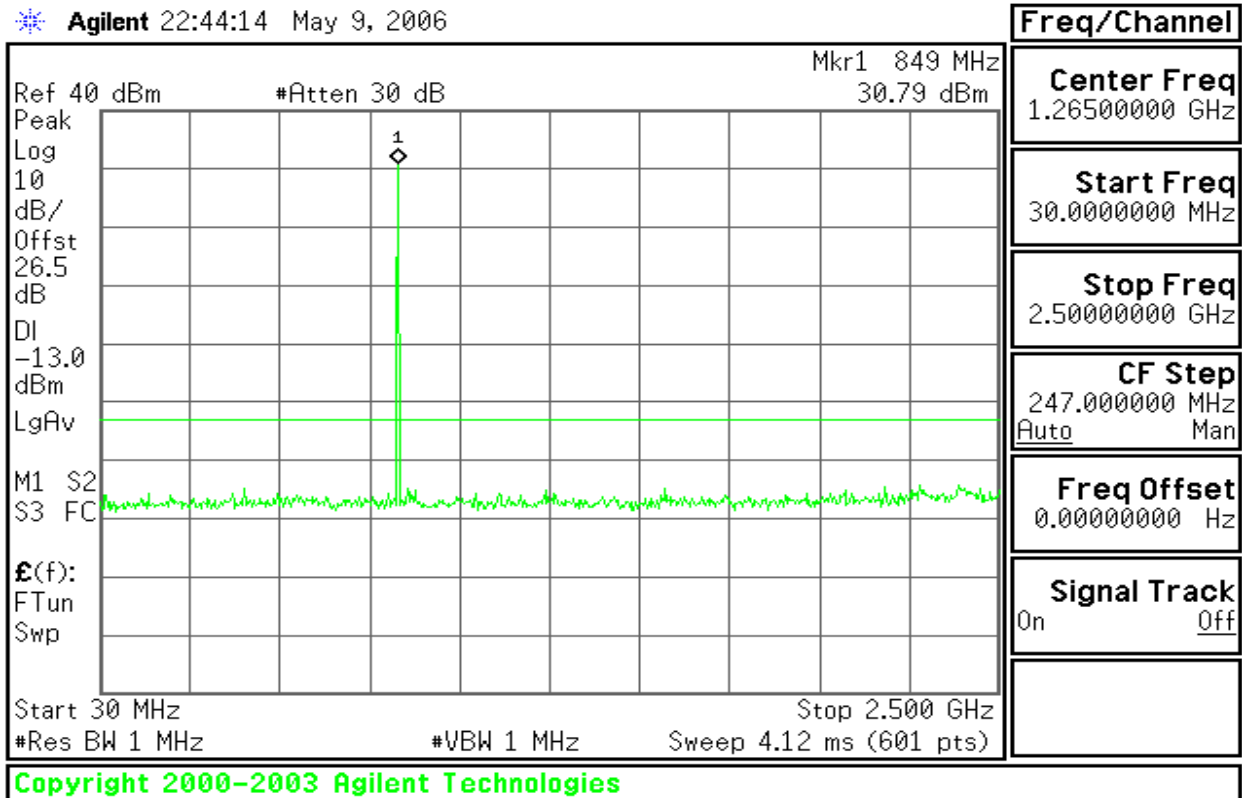
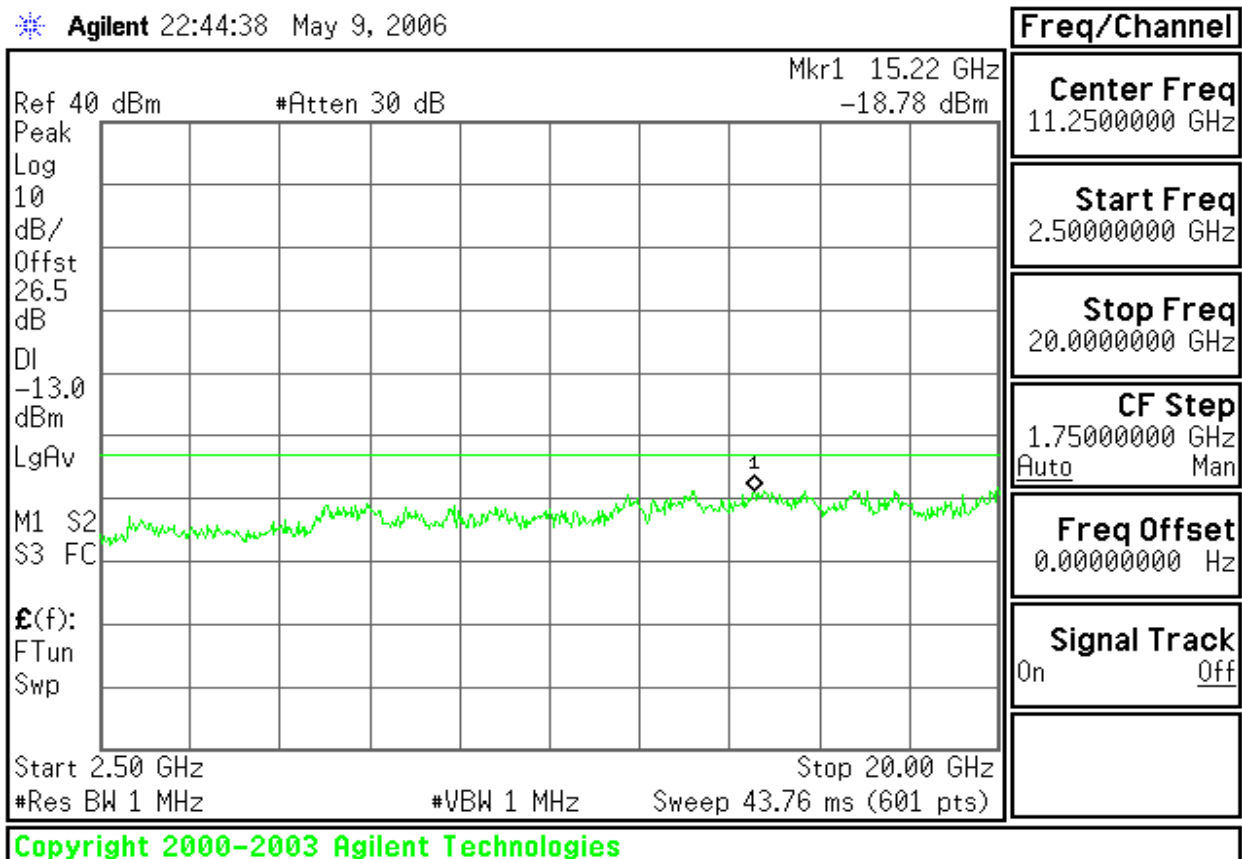

Figure 7-6: Out of Band emission at antenna terminals – GSM CH High

Agilent 22:44:38 May 9, 2006





## GSM 1900

Figure 8-1: Out of Band emission at antenna terminals – GSM CH Low

Agilent 22:27:28 May 9, 2006

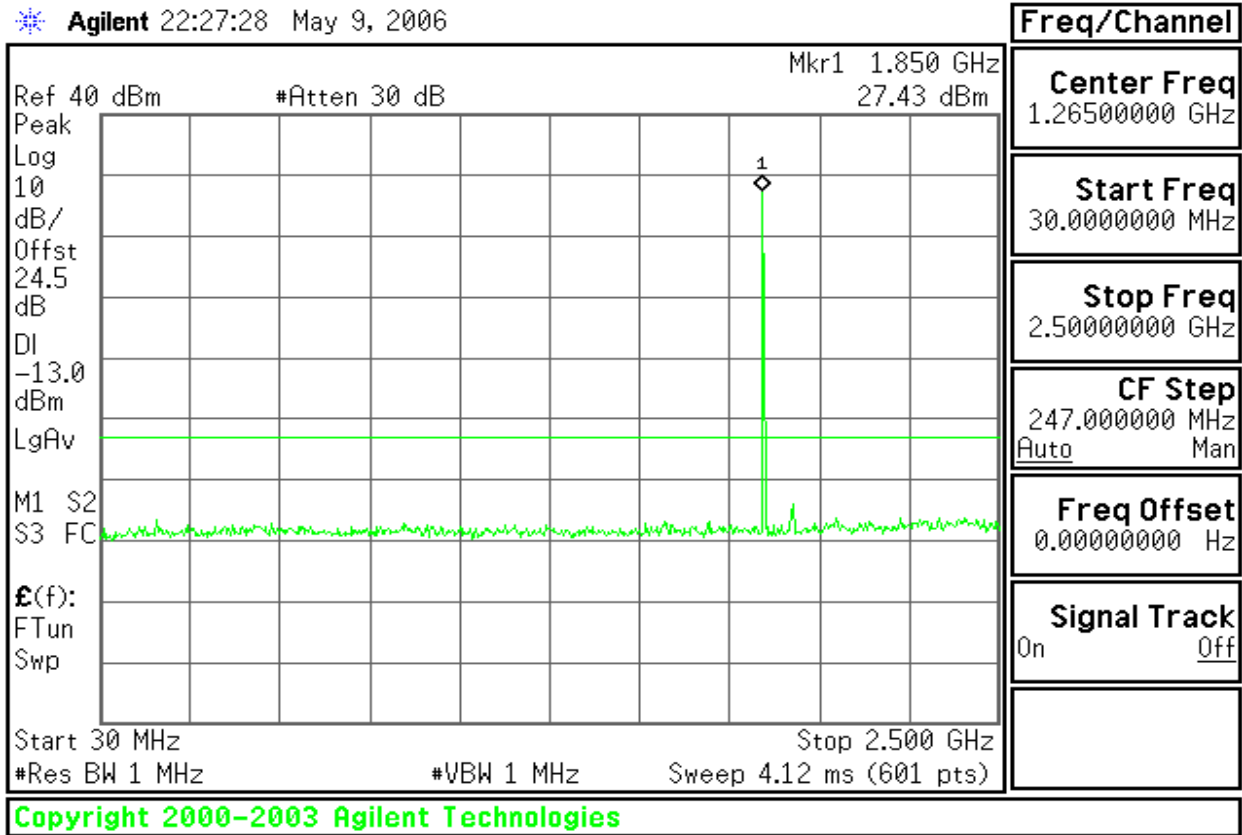

Figure 8-2: Out of Band emission at antenna terminals – GSM CH Low

Agilent 22:27:53 May 9, 2006

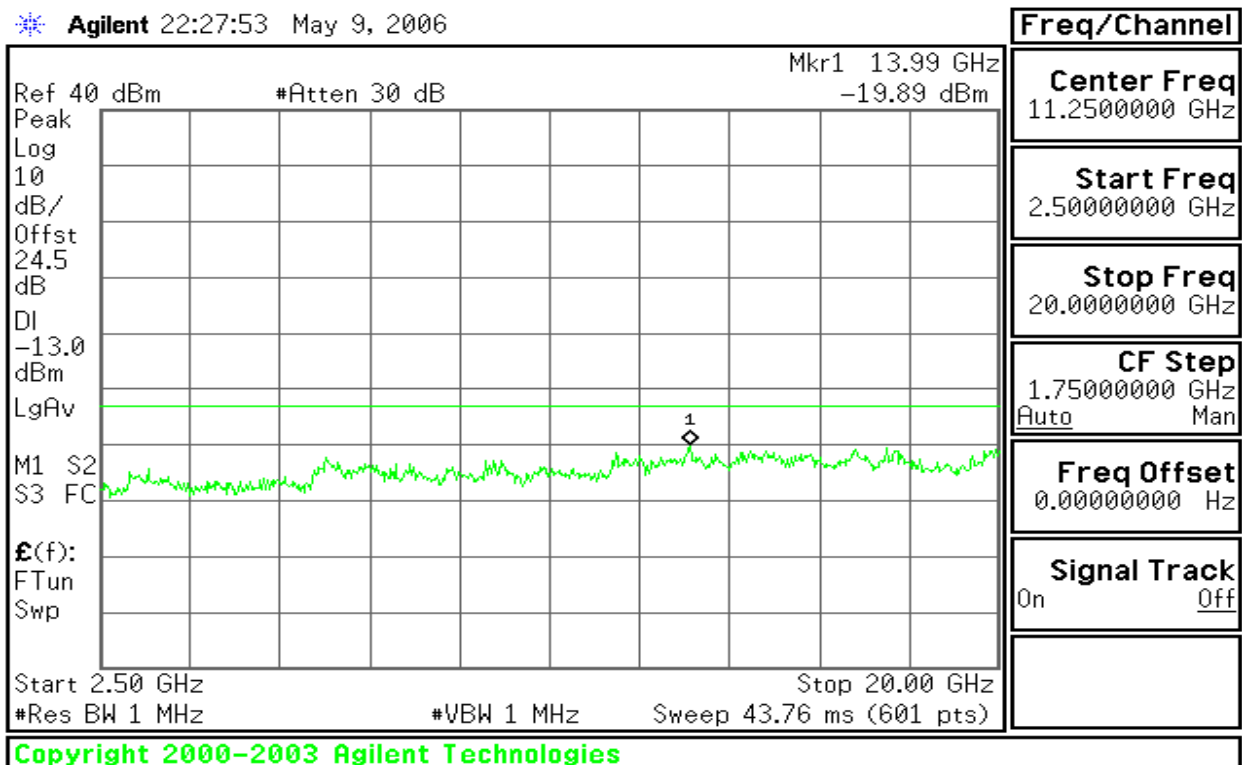

Figure 8-3: Out of Band emission at antenna terminals – GSM CH Mid

Agilent 22:28:44 May 9, 2006

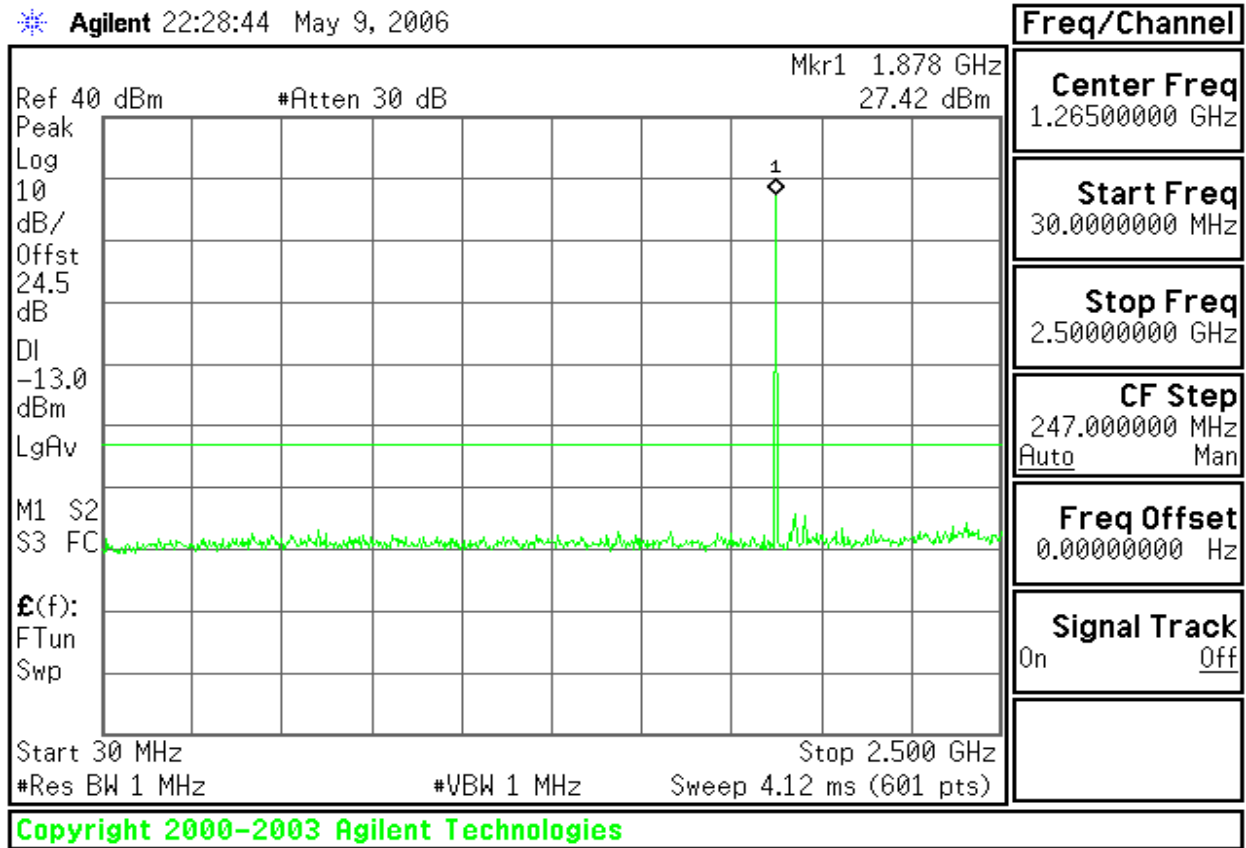

Figure 8-4: Out of Band emission at antenna terminals – GSM CH Mid

Agilent 22:28:16 May 9, 2006

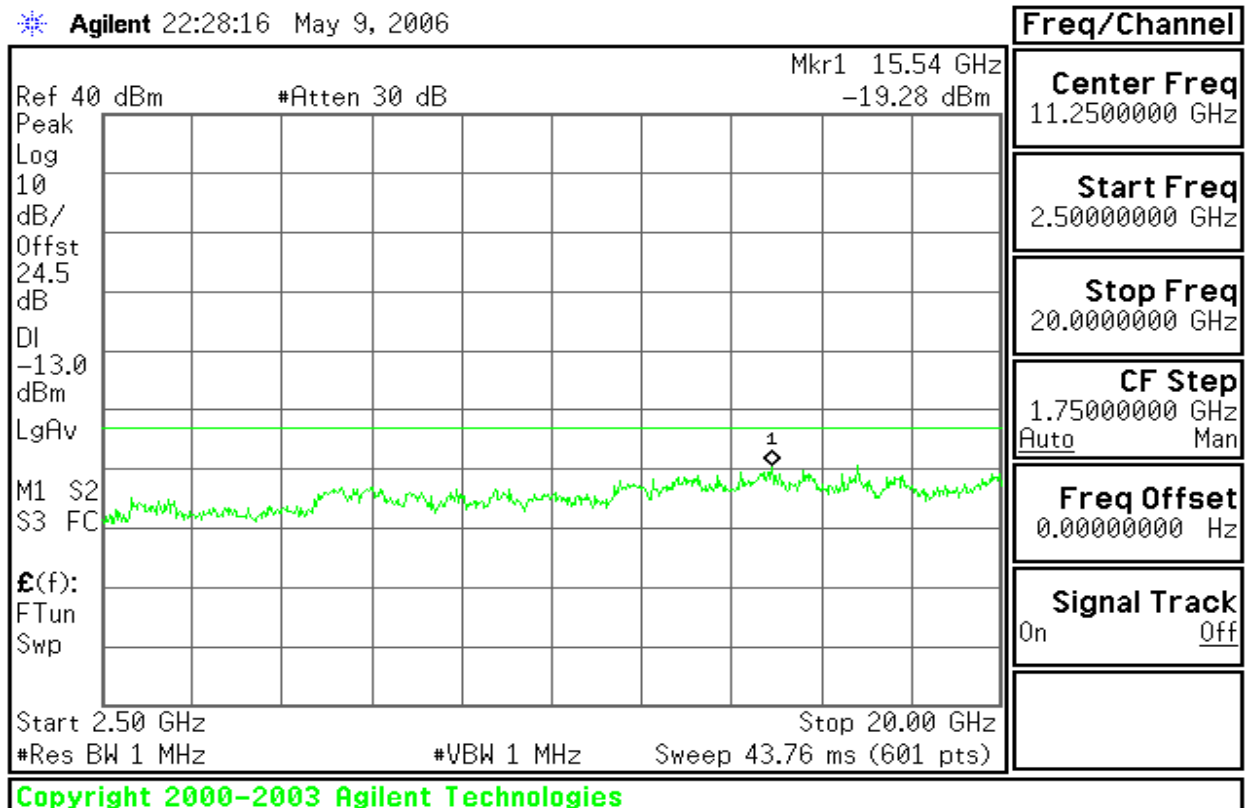

Figure 8-5: Out of Band emission at antenna terminals – GSM CH High

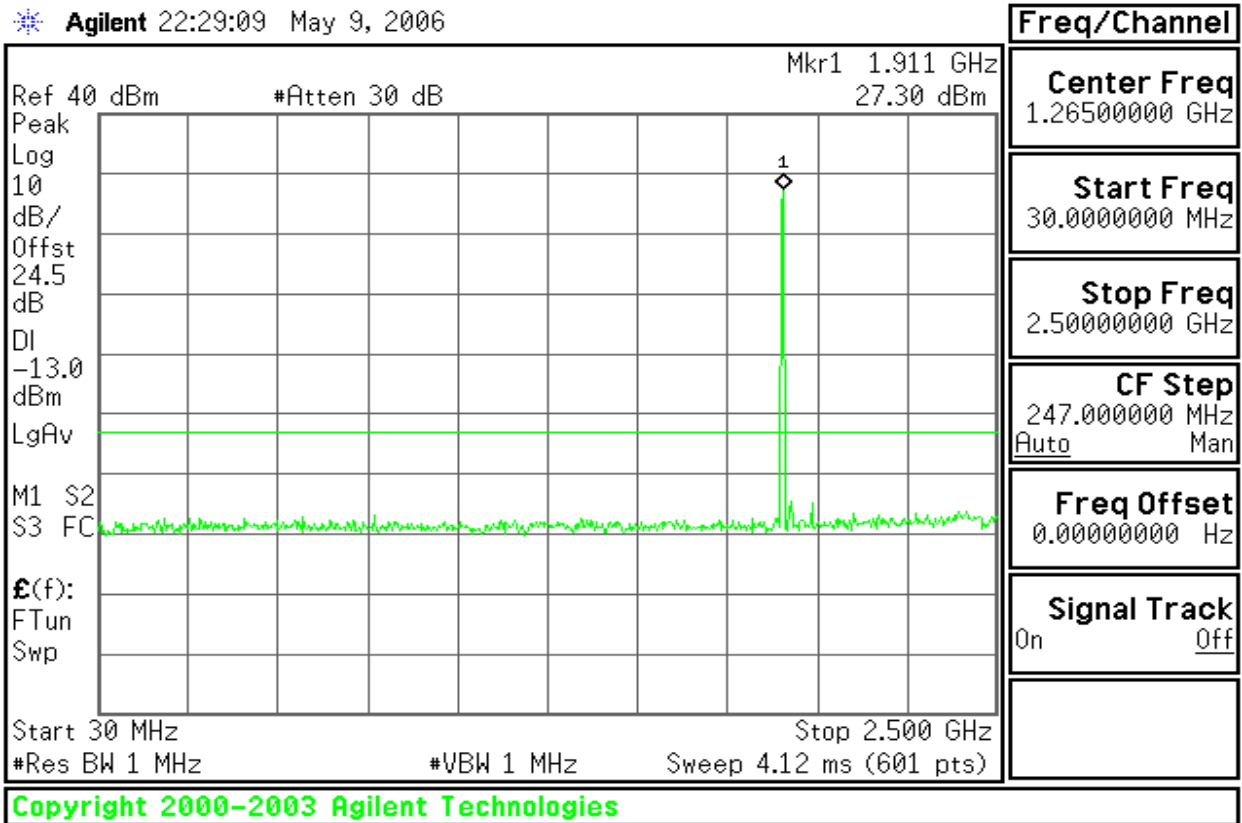
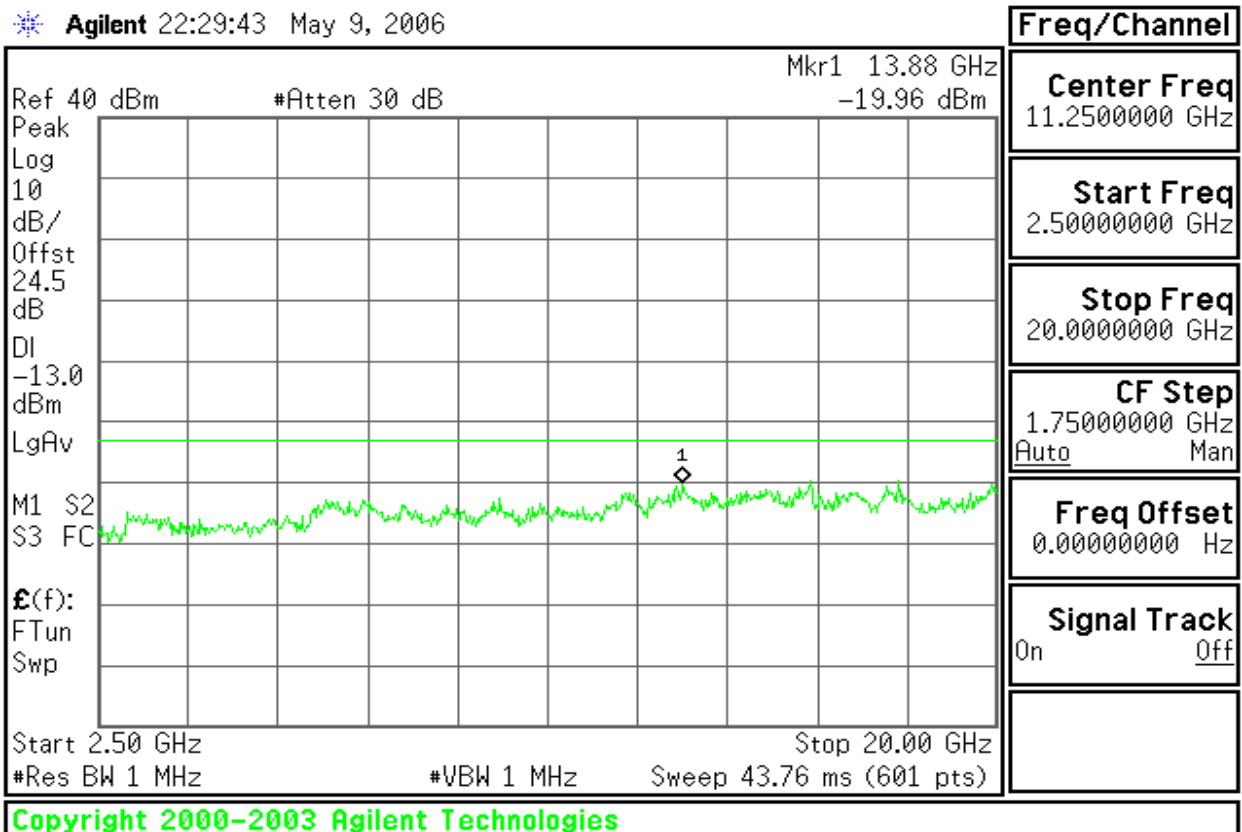

Figure 8-6: Out of Band emission at antenna terminals – GSM CH High





### GSM 850

Figure 9-1: Band Edge emissions – GSM CH Low

Agilent 22:37:11 May 9, 2006

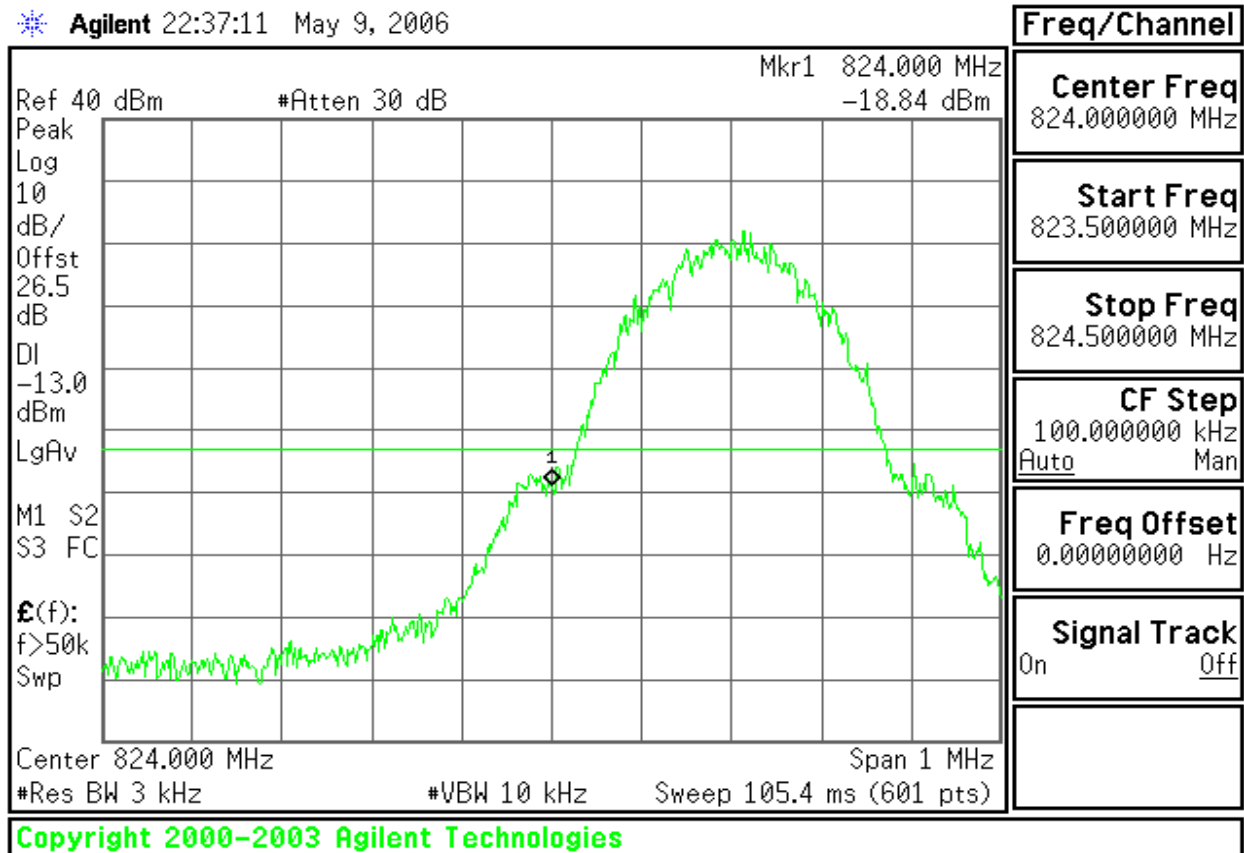
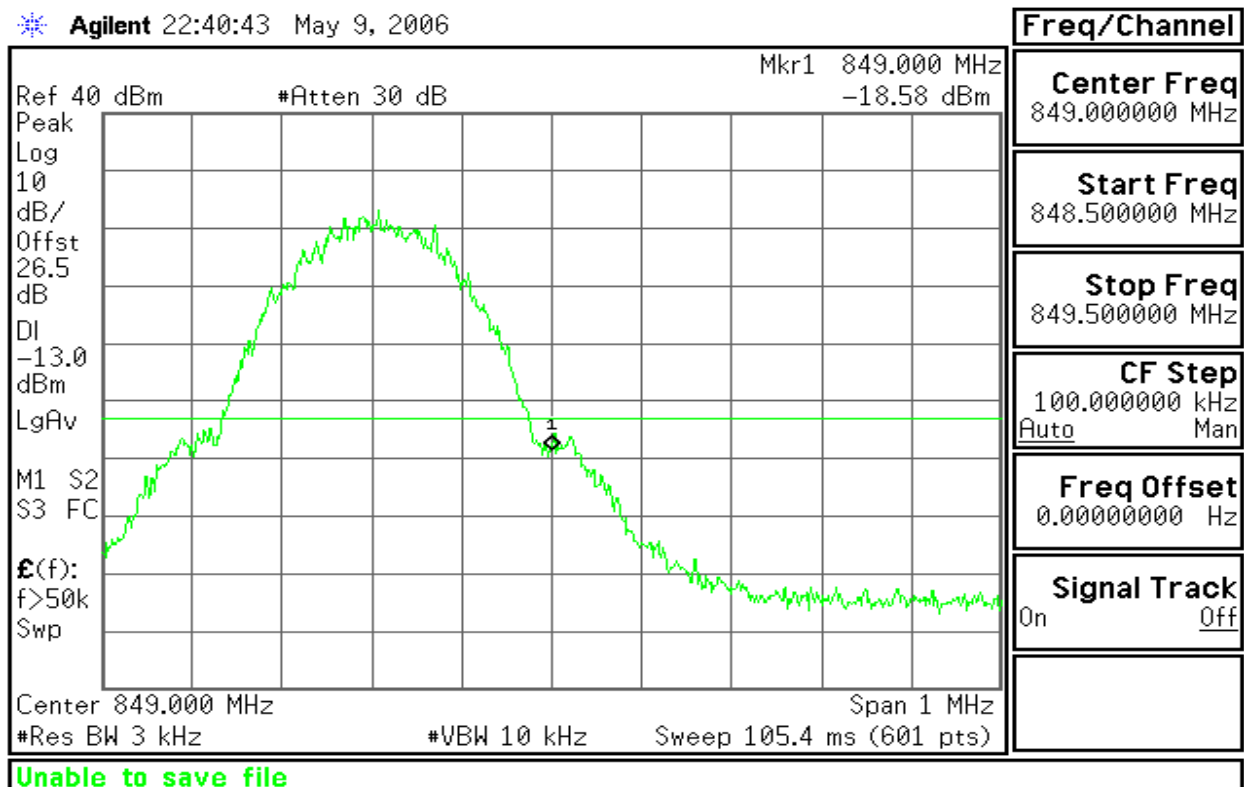

Figure 9-2: Band Edge emissions – GSM CH High

Agilent 22:40:43 May 9, 2006







## GSM 1900

Figure 10-1: Band Edge emissions – GSM CH Low

Agilent 22:34:01 May 9, 2006

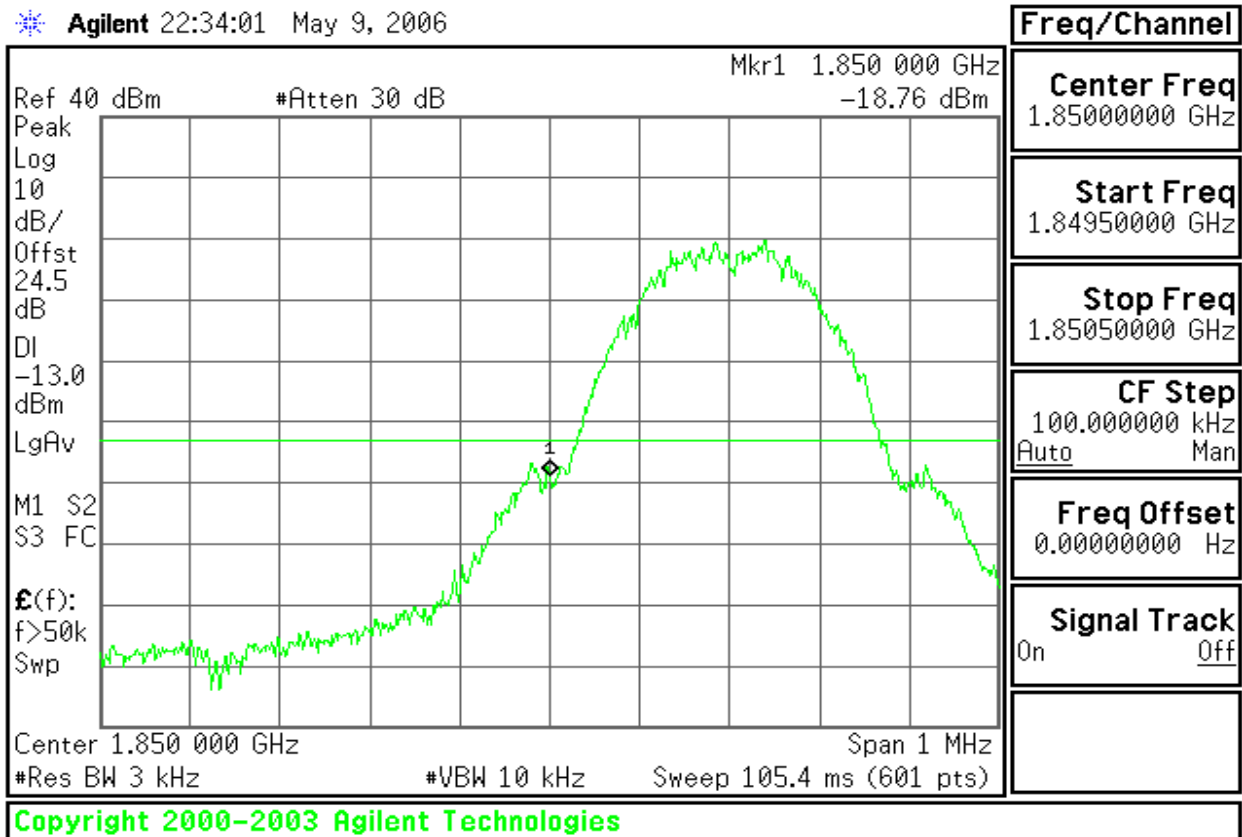
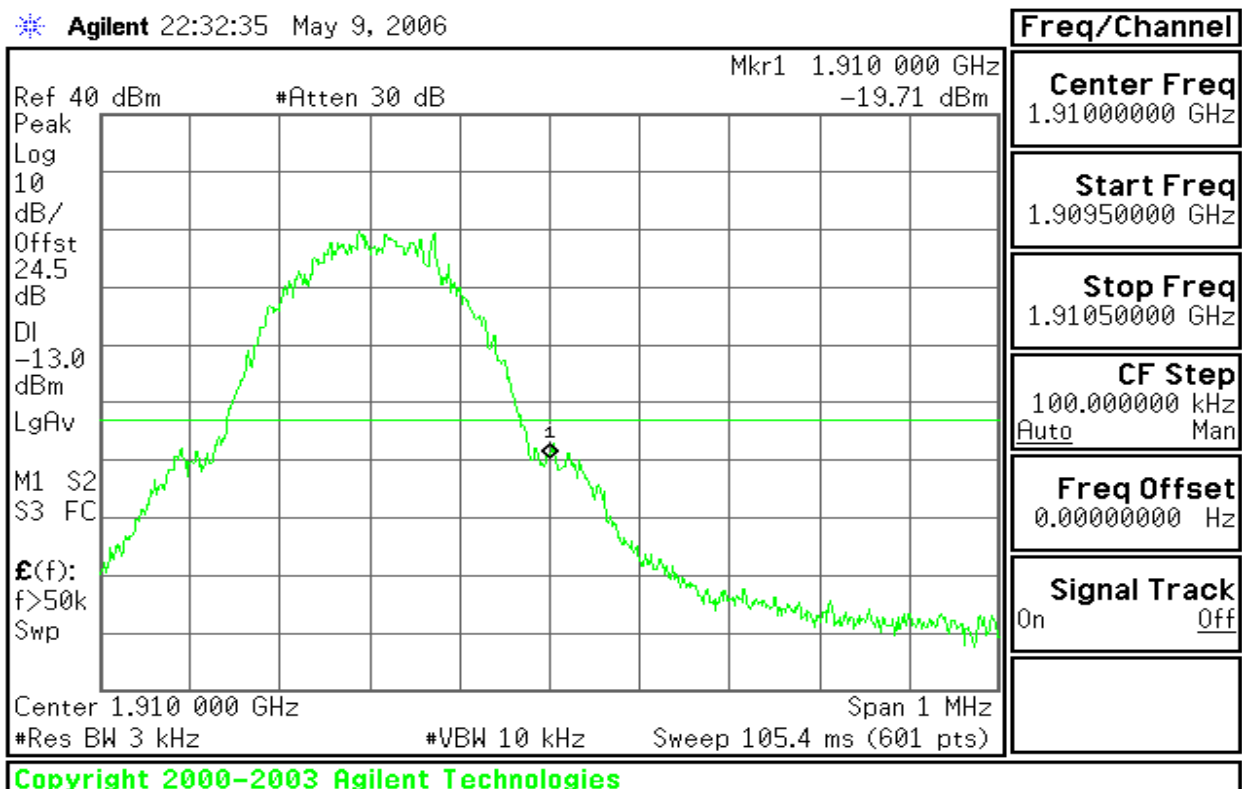

Figure 10-2: Band Edge emissions – GSM CH High

Agilent 22:32:35 May 9, 2006





## FIELD STRENGTH OF SPURIOUS RADIATION MEASUREMENT

### LIMIT

According to FCC §2.1053

### MEASUREMENT EQUIPMENT USED

977 Chamber (3m)				
Name of Equipment	Manufacturer	Model	Serial Number	Calibration Due
Spectrum Analyzer	Agilent	E4446A	MY44020154	08/16/2006
EMI Test Receiver	R&S	ESPI3	101026	11/11/2006
Pre-Amplifier	MINI-circuits	ZFL-1000VH2	d041703	12/13/2006
Pre-Amplifier	Miteq	NSP4000-NF	870731	01/28/2007
Bilog Antenna	Sunol	JB1	A110204-2	11/22/2006
Horn-antenna	SCHWARZBECK	BBHA9120D	D:266	02/01/2007
PSG Analog Signal Generator	Agilent	E8257C	MY43321570	12/19/2006
Wireless communication test set	Agilent	8960	QB44051695	10/06/2006
Turn Table	CT	CT123	4165	N.C.R
Antenna Tower	CT	CTERG23	3256	N.C.R
Controller	CT	CT100	95637	N.C.R
Site NSA	CCS	N/A	N/A	04/06/2007

**Remark:** Each piece of equipment is scheduled for calibration once a year.

**Test Configuration**

**Below 1 GHz**

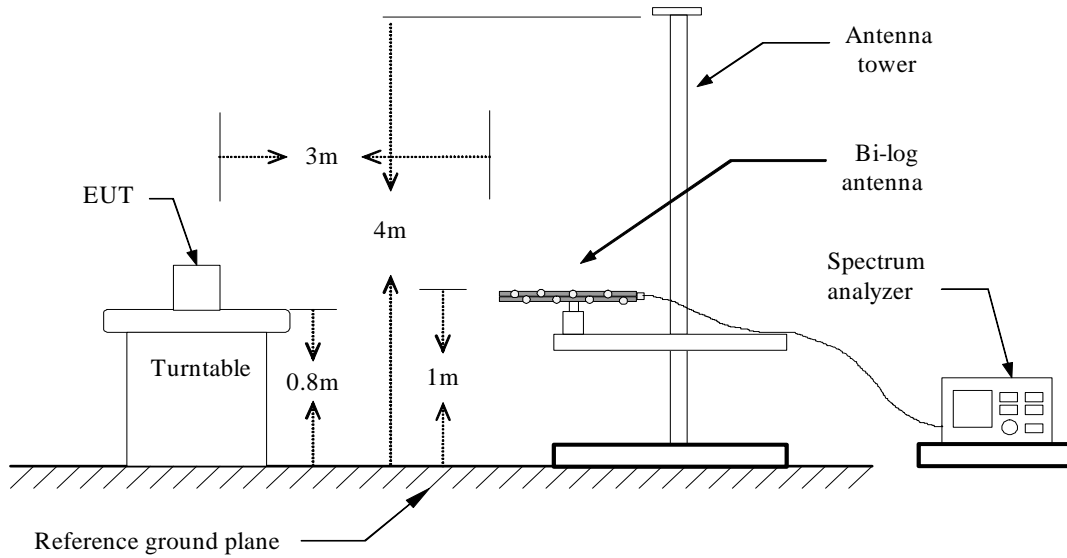

**Above 1 GHz**

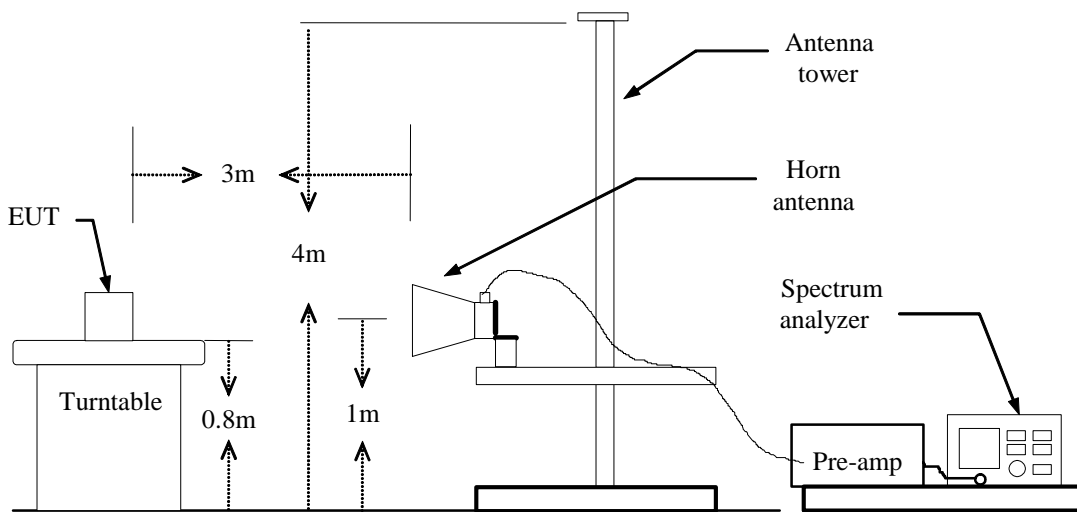

**Substituted Method Test Set-up**

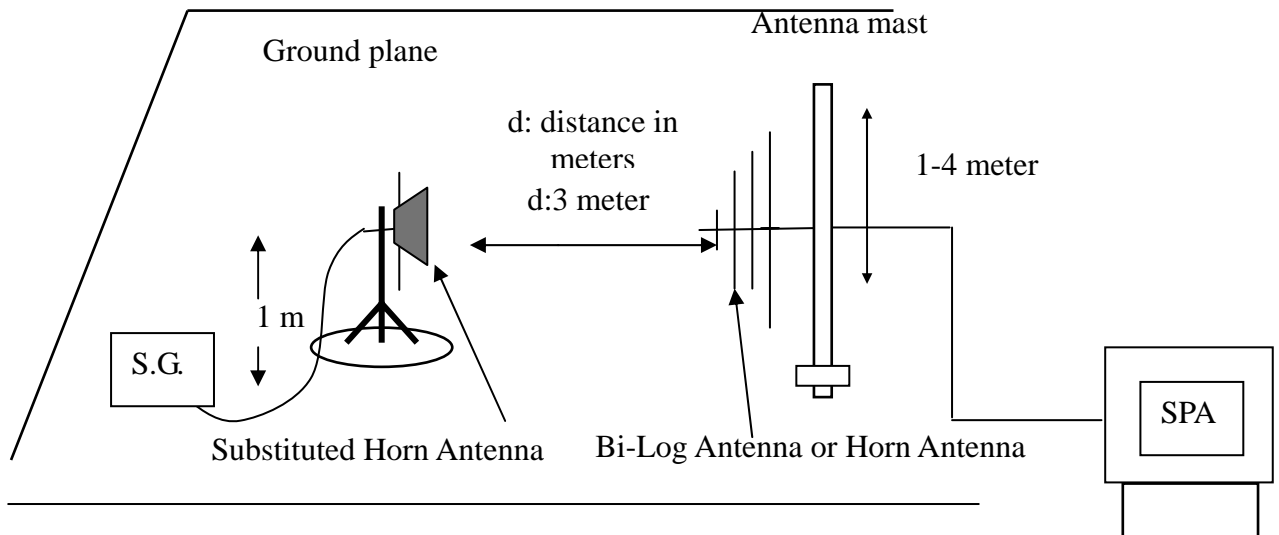



## **TEST PROCEDURE**

The EUT was placed on a non-conductive, the measurement antenna was placed at a distance of 3 meters from the EUT. During the tests, the antenna height and the EUT azimuth were varied in order to identify the maximum level of emissions from the EUT. This maximization process was repeated with the EUT positioned in each of its three orthogonal orientations.

The frequency range up to tenth harmonic was investigated for each of three fundamental frequency (low, middle and high channels). Once spurious emission were identified, the power of the emission was determined using the substitution method.

The spurious emissions attenuation was calculated as the difference between radiated power at the fundamental frequency and the spurious emissions frequency.

ERP = S.G. output (dBm) + Antenna Gain (dBd) – Cable (dB)

EIRP = S.G. output (dBm) + Antenna Gain (dBi) – Cable (dB)

## **TEST RESULTS**

*Refer to the attached tabular data sheets.*



**Radiated Spurious Emission Measurement Result**

**Below 1GHz**

No emissions to be recorded.

(Since no specific emission noted beyond the background noise floor)

**Above 1GHz**

**Operation Mode:** GSM 850 / TX / CH 128

**Test Date:** May 11, 2006

**Temperature:** 25°C

**Tested by:** Jeff

**Humidity:** 55 % RH

**Polarity:** Ver. / Hor.

Frequency (MHz)	Reading level (dBuV)	Antenna Polarization	S.G. (dBm)	Cable loss (dB)	Ant.Gain (dBd)	Emission level (dBm)	Limit (dBm)	Margin (dB)
1648.81	31.52	V	-81.71	4.01	7.86	-77.86	-13.00	-64.86
1648.63	34.11	H	-83.46	4.01	7.86	-79.61	-13.00	-66.61

**Operation Mode:** GSM 850 / TX / CH 190

**Test Date:** May 11, 2006

**Temperature:** 25°C

**Tested by:** Jeff

**Humidity:** 55 % RH

**Polarity:** Ver. / Hor.

Frequency (MHz)	Reading level (dBuV)	Antenna Polarization	S.G. (dBm)	Cable loss (dB)	Ant.Gain (dBd)	Emission level (dBm)	Limit (dBm)	Margin (dB)
1673.89	34.06	V	-75.38	4.21	7.95	-71.64	-13.00	-58.64
1673.37	36.11	H	-74.79	4.21	7.95	-71.05	-13.00	-58.05

**Operation Mode:** GSM 850 / TX / CH 251

**Test Date:** May 11, 2006

**Temperature:** 25°C

**Tested by:** Jeff

**Humidity:** 55 % RH

**Polarity:** Ver. / Hor.

Frequency (MHz)	Reading level (dBuV)	Antenna Polarization	S.G. (dBm)	Cable loss (dB)	Ant.Gain (dBd)	Emission level (dBm)	Limit (dBm)	Margin (dB)
1697.51	35.54	V	-76.75	4.53	8.12	-73.16	-13.00	-60.16
1697.67	34.62	H	-75.41	4.53	8.12	-71.82	-13.00	-58.82

**Remark:**

1. Measuring frequencies from 1 GHz to the 10th harmonic of highest fundamental frequency.
2. Measurements above shown only up to 6 maximum emissions noted, or would be lesser, with " N/A " remark, if no specific emissions from the EUT are recorded (ie: margin>20dB from the applicable limit) and considered that's already beyond the background noise floor.



3. *Data of measurement within this frequency range shown “ --- ” in the table above means the reading of emissions are attenuated more than 20dB below the permissible limits or the field strength is too small to be measured.*
4. *Radiated emissions measured in frequency above 1000MHz were made with an instrument using Peak detector mode and average detector mode of the emission shown in Actual FS column.*
5. *Spectrum setting:*
  - a. *Peak Setting 1GHz to 10th harmonics of fundamental, RBW = 1MHz, VBW = 1MHz, Sweep time = Auto.*
  - b. *AV Setting 1GHz to 10th harmonics of fundamental, RBW = 1MHz, VBW = 10Hz, Sweep time = Auto.*

**Below 1GHz**

No emissions to be recorded.

(Since no specific emission noted beyond the background noise floor)

**Above 1GHz****Operation Mode:** GSM 1900 / TX / CH 512**Test Date:** May 11, 2006**Temperature:** 25°C**Tested by:** Jeff**Humidity:** 55 % RH**Polarity:** Ver. / Hor.

Frequency (MHz)	Reading level (dBuV)	Antenna Polarization	S.G. (dBm)	Cable loss (dB)	Ant.Gain (dBi)	Emission level (dBm)	Limit (dBm)	Margin (dB)
3700.38	27.08	V	-75.31	6.65	13.40	-68.56	-13.00	-55.56
3700.71	25.66	H	-70.18	6.65	13.40	-63.43	-13.00	-50.43

**Operation Mode:** GSM 1900 / TX / CH 661**Test Date:** May 11, 2006**Temperature:** 25°C**Tested by:** Jeff**Humidity:** 55 % RH**Polarity:** Ver. / Hor.

Frequency (MHz)	Reading level (dBuV)	Antenna Polarization	S.G. (dBm)	Cable loss (dB)	Ant.Gain (dBi)	Emission level (dBm)	Limit (dBm)	Margin (dB)
3760.58	26.23	V	-73.72	6.75	13.56	-66.91	-13.00	-53.91
3759.49	27.31	H	-74.67	6.75	13.56	-67.86	-13.00	-54.86

**Operation Mode:** GSM 1900 / TX / CH 810**Test Date:** May 11, 2006**Temperature:** 25°C**Tested by:** Jeff**Humidity:** 55 % RH**Polarity:** Ver. / Hor.

Frequency (MHz)	Reading level (dBuV)	Antenna Polarization	S.G. (dBm)	Cable loss (dB)	Ant.Gain (dBi)	Emission level (dBm)	Limit (dBm)	Margin (dB)
3819.62	26.79	V	-78.93	6.84	14.25	-71.52	-13.00	-58.52
3819.83	25.36	H	-77.28	6.84	14.25	-69.87	-13.00	-56.87

**Remark:**

1. Measuring frequencies from 1 GHz to the 10th harmonic of highest fundamental frequency.
2. Measurements above shown only up to 6 maximum emissions noted, or would be lesser, with " N/A " remark, if no specific emissions from the EUT are recorded (ie: margin>20dB from the applicable limit) and considered that's already beyond the background noise floor.
3. Data of measurement within this frequency range shown " --- " in the table above means the reading of emissions are attenuated more than 20dB below the permissible





*limits or the field strength is too small to be measured.*

*4. Radiated emissions measured in frequency above 1000MHz were made with an instrument using Peak detector mode and average detector mode of the emission shown in Actual FS column.*

*5. Spectrum setting:*

*a. Peak Setting 1GHz to 10th harmonics of fundamental, RBW = 1MHz, VBW = 1MHz, Sweep time = Auto.*

*b. AV Setting 1GHz to 10th harmonics of fundamental, RBW = 1MHz, VBW = 10Hz, Sweep time = Auto.*

## FREQUENCY STABILITY V.S. TEMPERATURE MEASUREMENT

### LIMIT

According to FCC §2.1055, FCC §24.235.

Frequency Tolerance: 2.5 ppm

### MEASUREMENT EQUIPMENT USED

Name of Equipment	Manufacturer	Model	Serial Number	Calibration Due
DC POWER SUPPLY	GW instek	GPS-3303C	E903131	04/15/2007
Spectrum Analyzer	Agilent	E4446A	MY44020154	08/16/2006
Wireless communication test set	Agilent	8960	QB44051695	10/06/2006
Temp. / Humidity Chamber	Kingson	THS-M1	242	05/26/2006

*Remark: Each piece of equipment is scheduled for calibration once a year.*

### Test Configuration

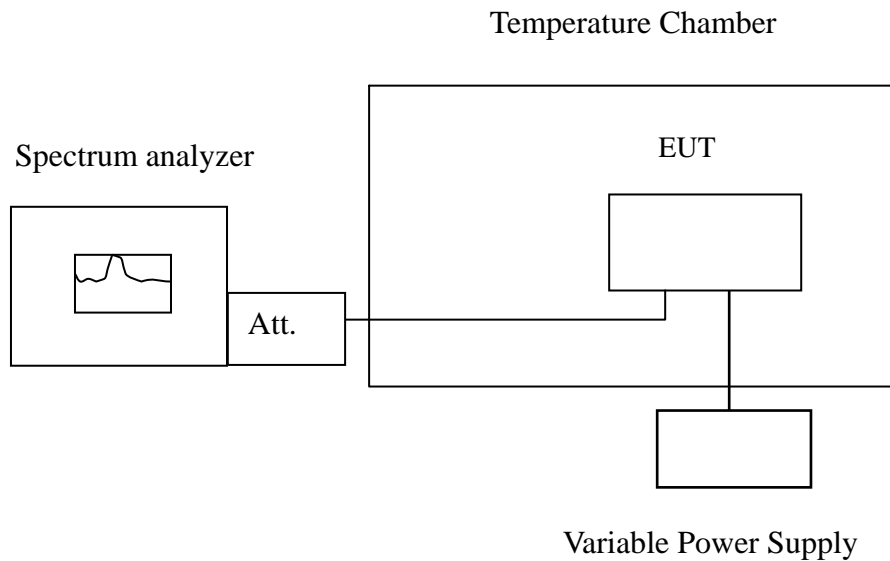

*Remark: Measurement setup for testing on Antenna connector*



**TEST PROCEDURE**

The equipment under test was connected to an external AC or DC power supply and input rated voltage. RF output was connected to a frequency counter or spectrum analyzer via feed through attenuators. The EUT was placed inside the temperature chamber. Set the spectrum analyzer RBW low enough to obtain the desired frequency resolution and measure EUT 20°C operating frequency as reference frequency. Turn EUT off and set the chamber temperature to -30°C. After the temperature stabilized for approximately 30 minutes recorded the frequency. Repeat step measure with 10°C increased per stage until the highest temperature of +50°C reached.

**TEST RESULTS**

No non-compliance noted.

Reference Frequency: GSM Mid Channel 836.6 MHz @ 20°C				
Limit: ± 2.5 ppm = 2091.5 Hz				
Power Supply Vdc	Environment Temperature (°C)	Frequency (Hz)	Delta (Hz)	Limit (Hz)
3.7	50	836600014	43.00	2091.5
	40	836600018	45.00	
	30	836600016	40.00	
	20	836599974	0.00	
	10	836600030	54.00	
	0	836600024	46.00	
	-10	836600038	59.00	
	-20	836600024	50.00	
	-30	836600033	60.00	

Reference Frequency: GSM Mid Channel 1880 MHz @ 20°C				
Limit: ± 2.5 ppm = 4700 Hz				
Power Supply Vdc	Environment Temperature (°C)	Frequency (Hz)	Delta (Hz)	Limit (Hz)
3.7	50	187999972	-46.00	4700
	40	187999975	-43.00	
	30	187999969	-45.00	
	20	188000018	0.00	
	10	187999970	-59.00	
	0	187999968	-47.00	
	-10	187999971	-46.00	
	-20	187999966	-47.00	
	-30	187999965	-46.00	

## FREQUENCY STABILITY V.S. VOLTAGE MEASUREMENT

### LIMIT

According to FCC §2.1055, FCC §24.235,

Frequency Tolerance: 2.5 ppm.

### MEASUREMENT EQUIPMENT USED

Name of Equipment	Manufacturer	Model	Serial Number	Calibration Due
DC POWER SUPPLY	GW instek	GPS-3303C	E903131	04/15/2007
Spectrum Analyzer	Agilent	E4446A	MY44020154	08/16/2006
Wireless communication test set	Agilent	8960	QB44051695	10/06/2006
Temp. / Humidity Chamber	Kingson	THS-M1	242	05/26/2006

*Remark: Each piece of equipment is scheduled for calibration once a year.*

### Test Configuration

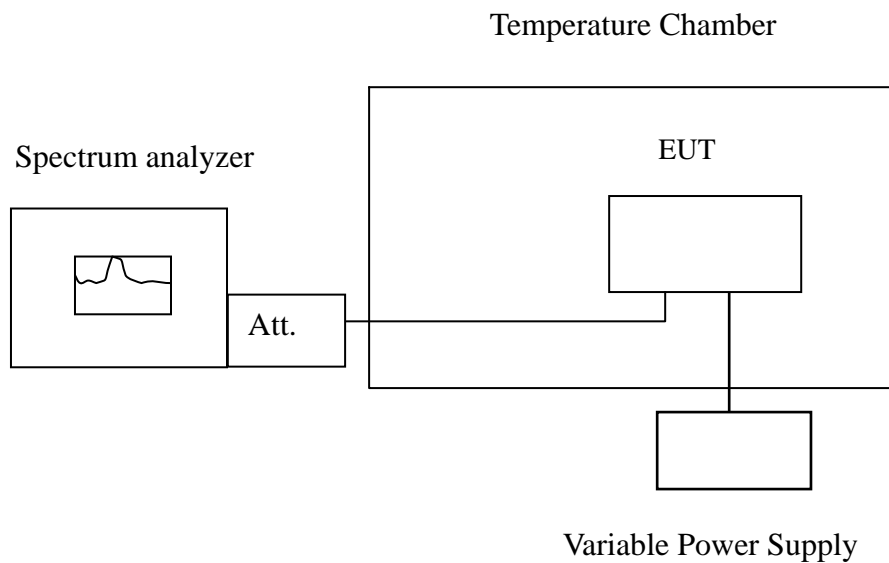

*Remark: Measurement setup for testing on Antenna connector.*



**TEST PROCEDURE**

Set chamber temperature to 20°C. Use a variable AC power supply / DC power source to power the EUT and set the voltage to rated voltage. Set the spectrum analyzer RBW low enough to obtain the desired frequency resolution and recorded the frequency.

Reduce the input voltage to specify extreme voltage variation (± 15%) and endpoint, record the maximum frequency change.

**TEST RESULTS**

*No non-compliance noted.*

Reference Frequency: GSM Mid Channel 836.6 MHz @ 20°C				
Limit: ± 2.5 ppm = 2091.5Hz				
Power Supply Vdc	Environment Temperature (°C)	Frequency (Hz)	Delta (Hz)	Limit (Hz)
4.3	20	836599971	-4	2091.5
3.7		836599974	0	
3.2 (End Point)		836599967	-8	

Reference Frequency: GSM Mid Channel 1880 MHz @ 20°C				
Limit: ± 2.5 ppm = 4700 Hz				
Power Supply Vdc	Environment Temperature (°C)	Frequency (Hz)	Delta (Hz)	Limit (Hz)
4.3	20	1880000025	6	4700
3.7		1880000020	0	
3.2 (End Point)		1880000019	0	



## POWERLINE CONDUCTED EMISSIONS

### LIMIT

For an intentional radiator which is designed to be connected to the public utility (AC) power line, the radio frequency voltage that is conducted back onto the AC power line on any frequency or frequencies within the band 150 kHz to 30 MHz shall not exceed 250 microvolts (The limit decreases linearly with the logarithm of the frequency in the range 0.15 MHz to 0.50 MHz). The limits at specific frequency range is listed as follows:

Frequency Range (MHz)	Limits (dB $\mu$ V)	
	Quasi-peak	Average
0.15 to 0.50	66 to 56	56 to 46
0.50 to 5	56	46
5 to 30	60	50

Compliance with this provision shall be based on the measurement of the radio frequency voltage between each power line (LINE and NEUTRAL) and ground at the power terminals.

### MEASUREMENT EQUIPMENT USED

Name of Equipment	Manufacturer	Model	Serial Number	Calibration Due
EMI Test Receiver	R&S	ESI26	100068	02/11/2007
EMC Analyzer	Agilent	E7402A	US41160329	02/11/2007
LISN	FCC	FCC-LISN-50-50-2-M	01067	07/29/2006
LISN (EUT)	FCC	FCC-LISN-50-50-2-M	01068	07/29/2006
TRANSIENT LIMITER	SCHAFFNER	CFL9206	1710	03/15/2007
EMI Monitor control box	FCC	0-SVDC	N/A	N.C.R

*Remark: Each piece of equipment is scheduled for calibration once a year.*

## Test Configuration

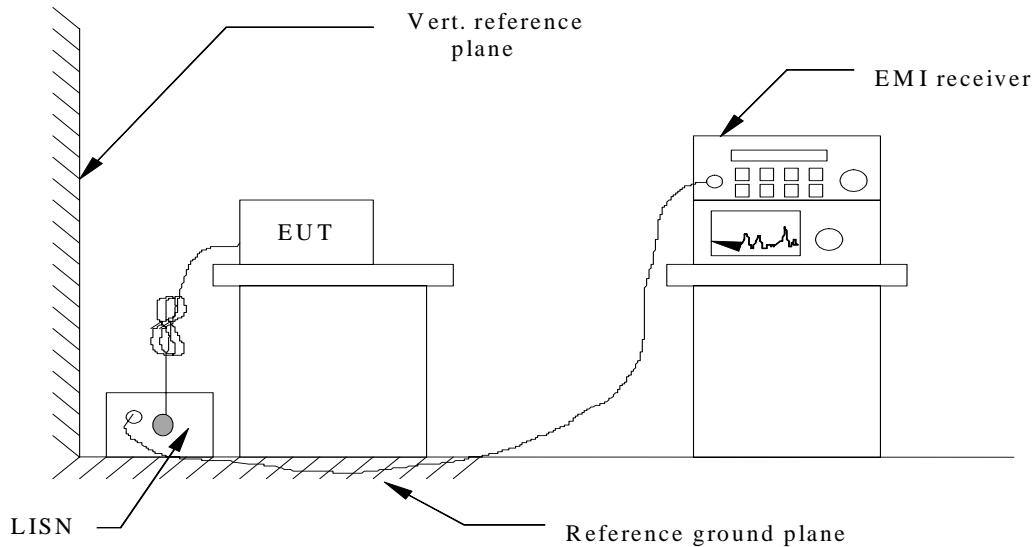

See test photographs attached in Appendix 1 for the actual connections between EUT and support equipment.

## TEST PROCEDURE

1. The EUT was placed on a table, which is 0.8m above ground plane.
2. Maximum procedure was performed on the six highest emissions to ensure EUT compliance.
3. Repeat above procedures until all frequency measured were complete.

## DECISION OF FINAL TEST MODE

1. The following test mode(s) were scanned during the preliminary test:
  1. AC to DC charger :Trade Name :Alcatel ; Model Number :3DS09371AGAA  
Manufactures: Astec
  2. AC to DC charger:Trade Name :Alcatel; Model Number :3DS09371AGAA  
Manufactures: Leader
  3. AC to DC charger: Trade Name :Alcatel; Model Number :3DS09371AAAA  
Manufactures: Astec
  4. AC to DC charger: Trade Name :Alcatel; Model Number : 3DS09371AAAA  
Manufactures: Leader
  5. DC to DC charger: Trade Name :Alcatel; Model Number :3DS07848AAAA  
Manufactures: Primax
2. After the preliminary scan, the following test mode was found to produce the highest emission level.
  2. AC to DC charger:Trade Name :Alcatel; Model Number :3DS09371AGAA  
Manufactures: Leader
  5. DC to DC charger: Trade Name :Alcatel; Model Number :3DS07848AAAA  
Manufactures: Primax



### TEST RESULTS

The initial step in collecting conducted data is a spectrum analyzer peak scan of the measurement range. Significant peaks are then marked as shown on the following data page, and these signals are then quasi-peaked.

Link mode

**Operation Mode:** (AC to DC charger) **Test Date:** May 11, 2006

**Temperature:** 25°C **Tested by:** Jeff

**Humidity:** 68% RH

Freq. (MHz)	PEAK. Raw (dBuV)	Q.P. Raw (dBuV)	AVG Raw (dBuV)	Q.P. Limit (dBuV)	AVG Limit (dBuV)	Margin (dB)	Factor (dB)	Remark
0.165	48.64	33.01	33.12	65.57	55.57	-22.45	10.37	L1
0.205	46.02	30.69	31.28	64.43	54.43	-23.15	10.36	L1
0.285	43.39	33.55	35.06	62.14	52.14	-17.08	10.39	L1
0.330	41.32	23.57	23.32	60.86	50.86	-27.54	10.40	L1
0.775	41.86	26.72	27.47	56.00	46.00	-18.53	10.42	L1
7.435	37.43	16.23	16.58	60.00	50.00	-33.42	10.93	L1
0.165	41.99	31.28	32.70	65.57	55.57	-22.87	10.41	L2
0.325	39.49	37.12	36.95	61.00	51.00	-14.05	10.40	L2
0.570	36.42	33.30	33.19	56.00	46.00	-12.81	10.39	L2
0.860	37.97	29.60	29.29	56.00	46.00	-16.71	10.41	L2
1.105	38.22	30.55	29.83	56.00	46.00	-16.17	10.43	L2
7.425	39.20	27.85	28.61	60.00	50.00	-21.39	10.99	L2





Link mode  
**Operation Mode:** (DC to DC charger) **Test Date:** May 11, 2006  
**Temperature:** 25°C **Tested by:** Jeff  
**Humidity:** 68% RH

Freq. (MHz)	Raw (dBuV)	Raw (dBuV)	Raw (dBuV)	Limit (dBuV)	Limit (dBuV)	(dB)	(dB)	Remark
0.530	35.26	16.83	15.01	56.00	46.00	-30.99	10.40	L1
0.665	37.83	17.91	18.23	56.00	46.00	-27.77	10.41	L1
0.775	48.74	15.97	15.66	56.00	46.00	-30.34	10.42	L1
0.820	46.16	14.27	14.50	56.00	46.00	-31.50	10.42	L1
0.950	43.58	16.42	18.17	56.00	46.00	-27.83	10.43	L1
1.105	35.32	14.26	12.73	56.00	46.00	-33.27	10.44	L1
0.235	33.45	20.45	20.34	63.57	53.57	-33.23	10.39	L2
0.700	37.63	16.37	15.21	56.00	46.00	-30.79	10.40	L2
0.775	48.99	13.13	15.62	56.00	46.00	-30.38	10.41	L2
0.905	43.88	14.17	14.01	56.00	46.00	-31.99	10.41	L2
1.035	39.18	15.77	13.28	56.00	46.00	-32.72	10.42	L2
1.160	30.48	16.83	14.92	56.00	46.00	-31.08	10.43	L2

**Remark:**

1. The measuring frequencies range between 0.15 MHz and 30 MHz.
2. The emissions measured in the frequency range between 0.15 MHz and 30MHz were made with an instrument using Quasi-peak detector and Average detector.
3. "---" denotes the emission level was or more than 2dB below the Average limit, and no re-check was made.
4. The IF bandwidth of SPA between 0.15MHz and 30MHz was 10KHz. The IF bandwidth of Test Receiver between 0.15MHz and 30MHz was 9kHz
5. L1 = Line One (Live Line) / L2 = Line Two (Neutral Line)

**Note:**

Freq. = Emission frequency in KHz

Factor (dB) = cable loss + Insertion loss of LISN+ Insertion loss of TRANSIENT LIMITER (The TRANSIENT LIMITER included 10 dB ATTENUATION)

Amptd dBuV = Uncorrected Analyzer/Receiver reading + cable loss + Insertion loss of LISN+ Insertion loss of TRANSIENT LIMITER, if it > 0.5 dB

Limit dBuV = Limit stated in standard



Margin dB = Reading in reference to limit

**Calculation Formula**

$$\text{Margin (dB)} = \text{Amptd (dBuV)} - \text{Limit (dBuV)}$$

**Test Plots**

**AC to DC charger**

Conducted emissions (Line 1)

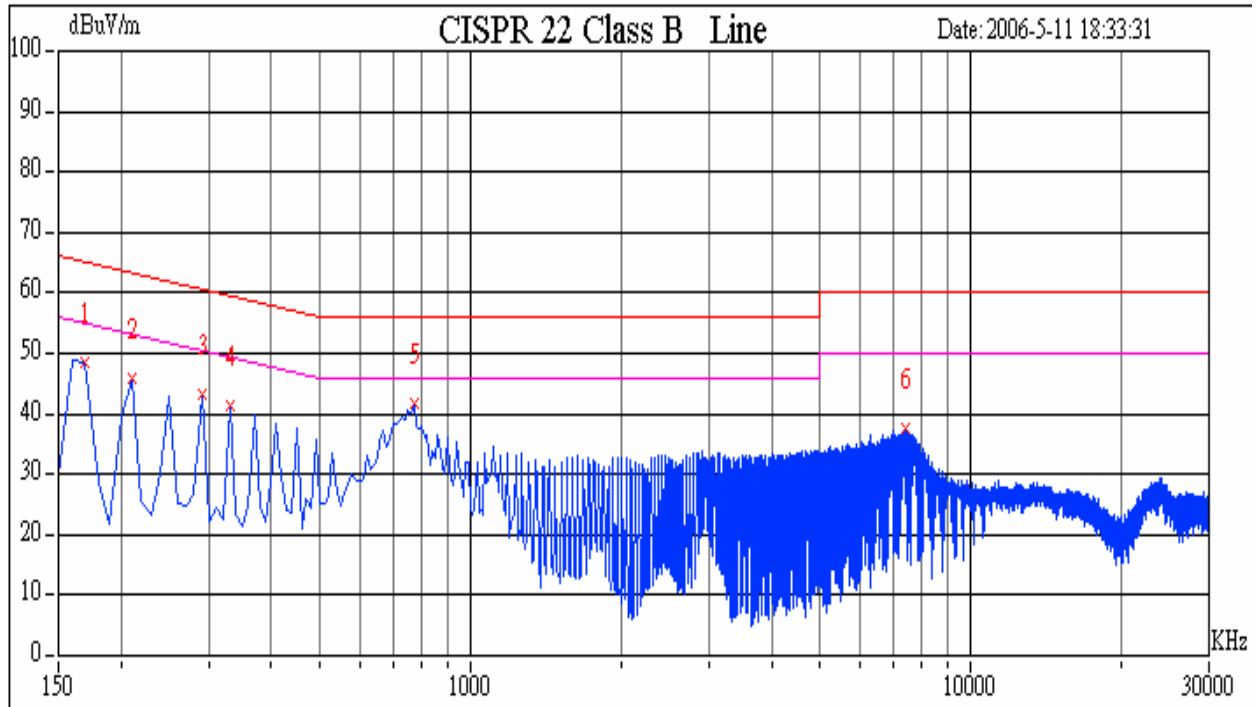

Conducted emissions (Line 2)

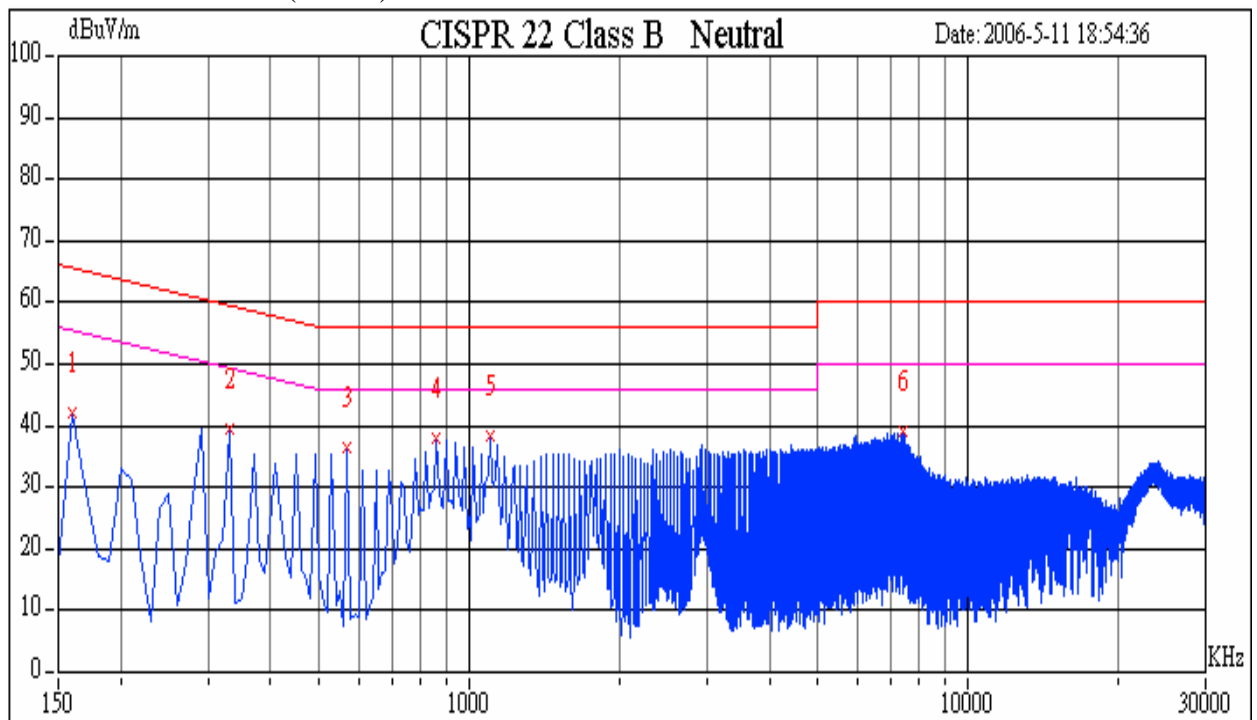



**Test Plots**

**DC to DC charger**

**Conducted emissions (Line 1)**

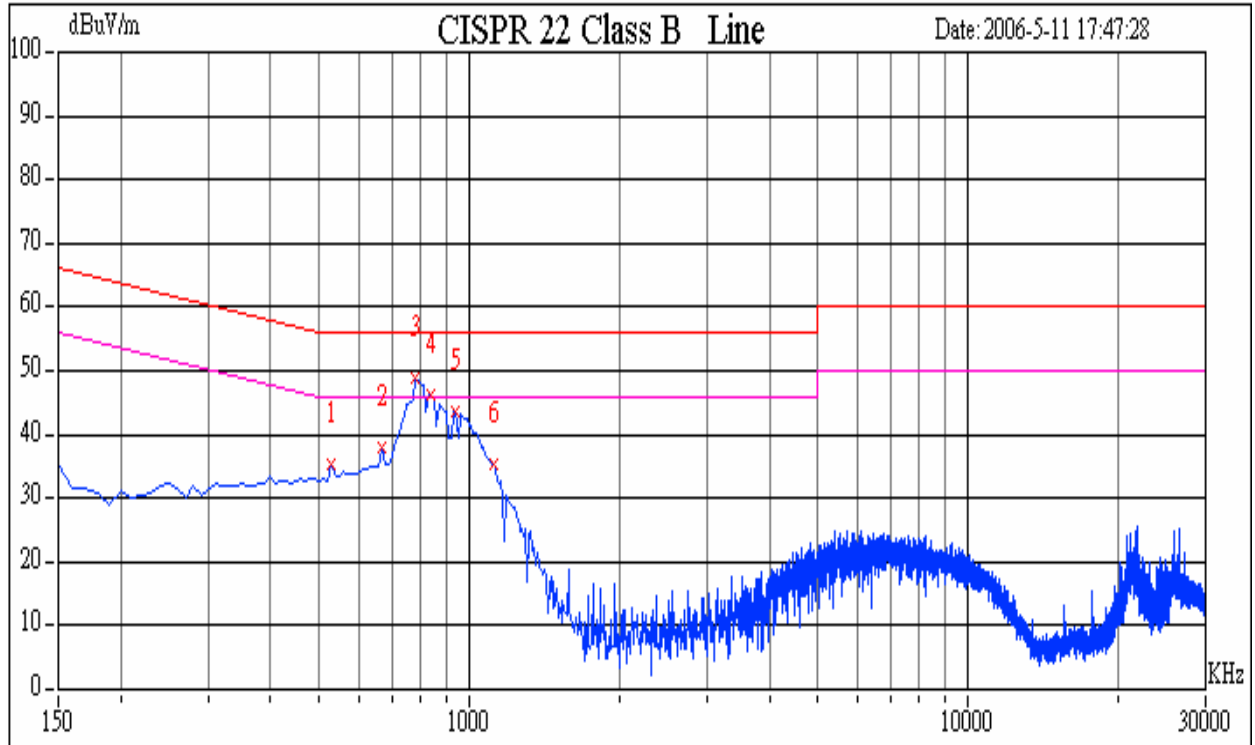

**Conducted emissions (Line 2)**

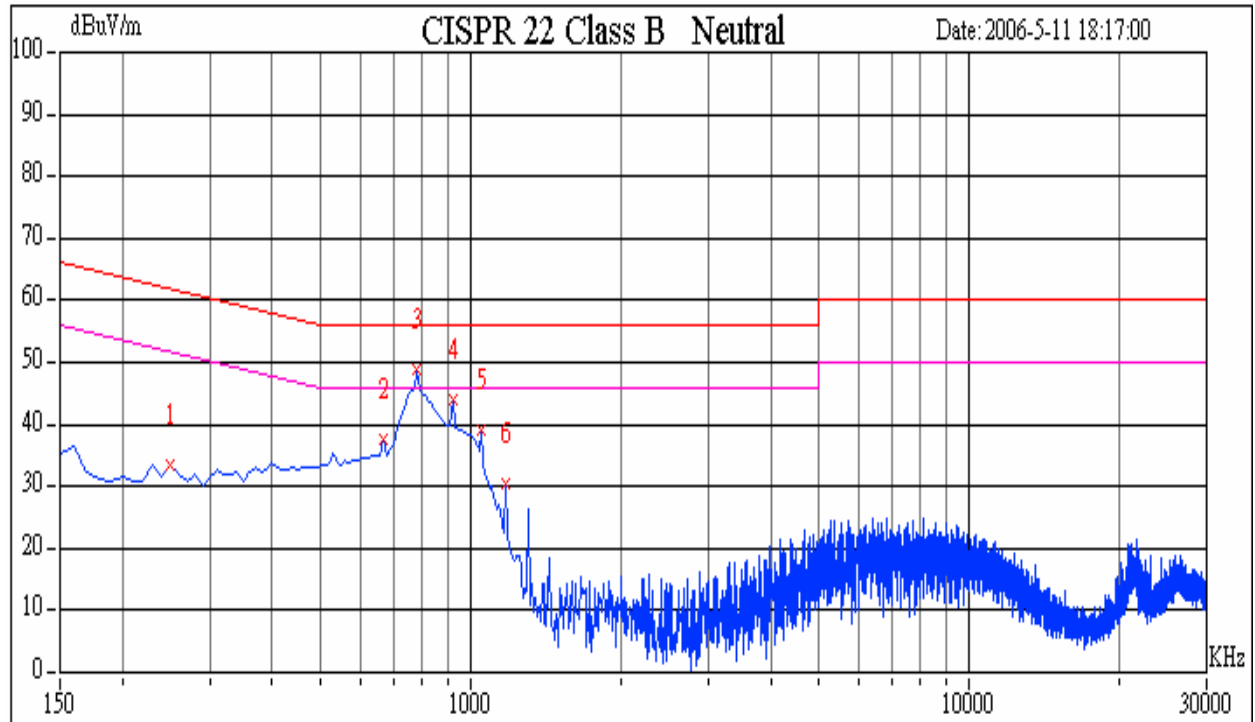

## APPENDIX 1 PHOTOGRAPHS OF TEST SETUP

### Radiated Emission Set up Photos

*Front of view*

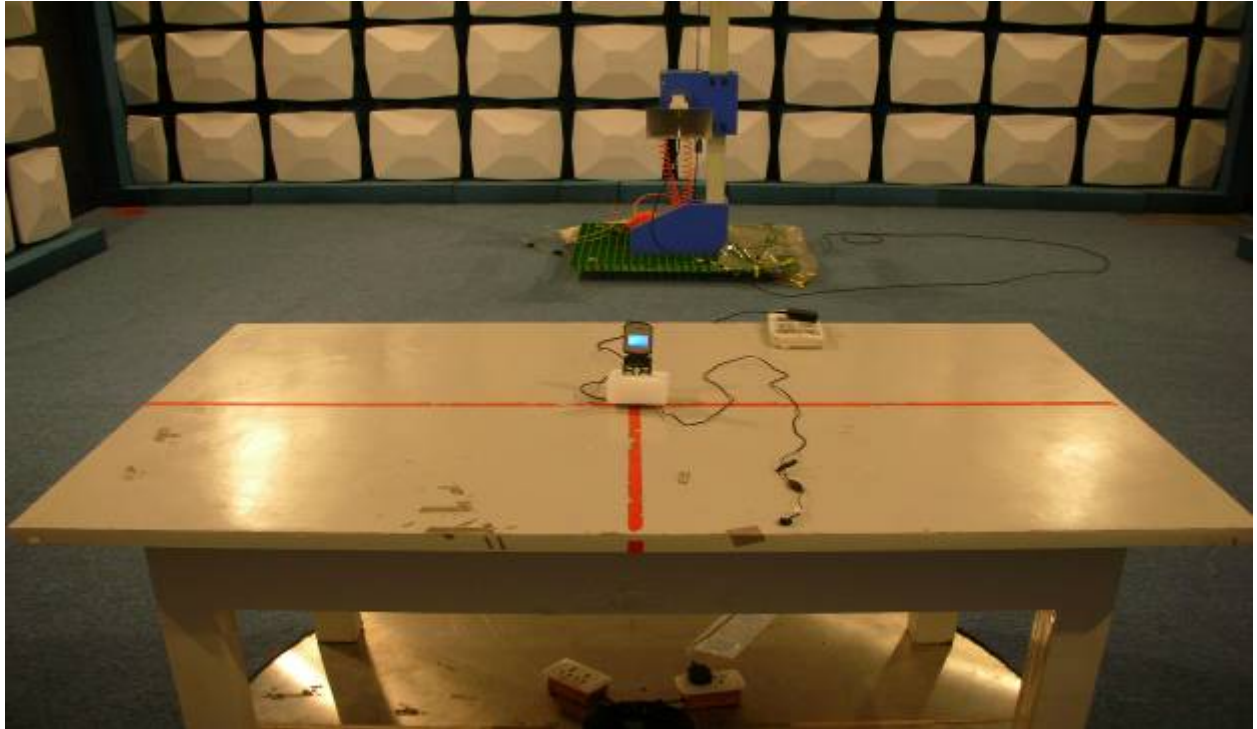

*Back of view*

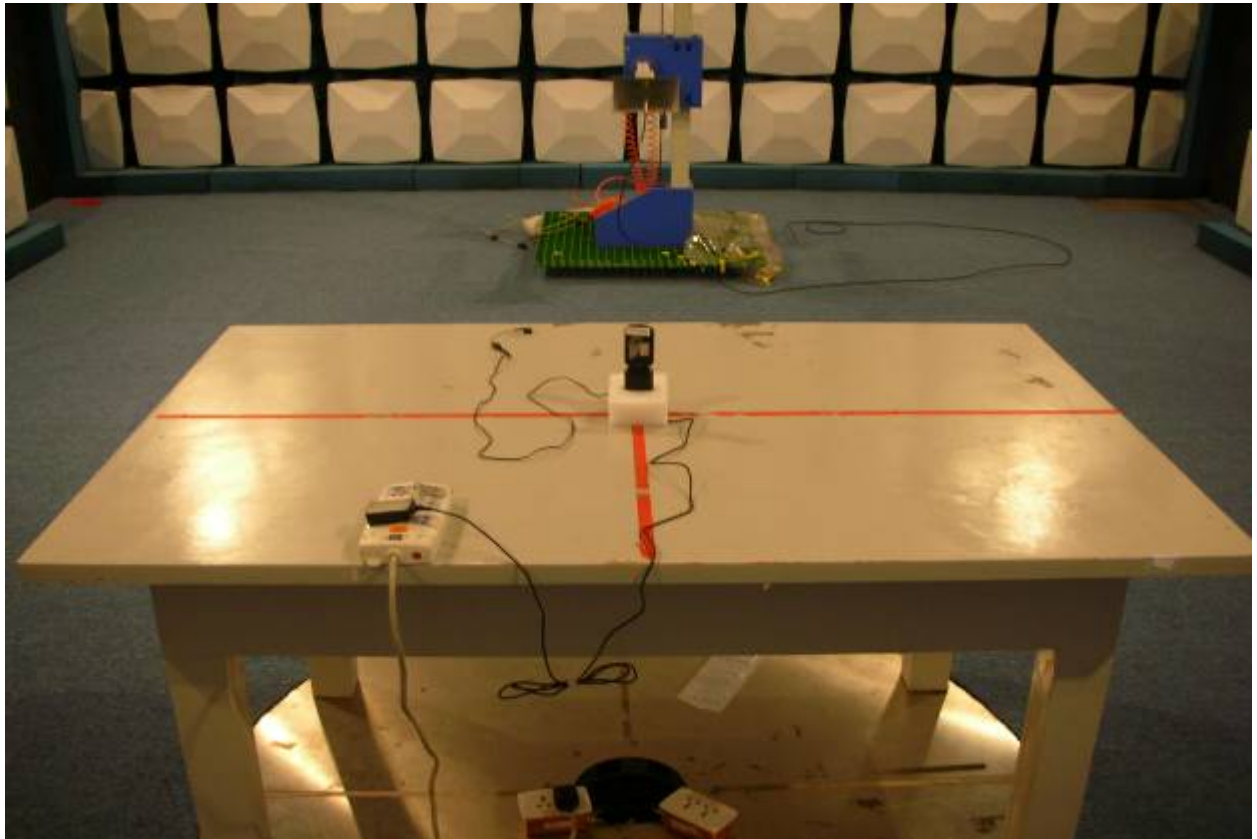



**Conducted Emission SetUp Photos**  
**AC to DC charger**

