

SAR TEST REPORT

Equipment Under Test :	GSM 850&PCS1900MHz MOBILE PHONE
Model No. :	D6Da
Market name:	OT-C635a
FCC ID	RAD034
Applicant :	T&A Mobile phones
Address of Applicant :	4/F, No.2966, Jinke Rd, Zhangjiang High-Tech Park, Pudong, Shanghai 201203. P. R. China
Date of Receipt :	2006.07.03
Date of Test :	2006.07.06 – 2006.07.13
Date of Issue :	2006.07.14

Standards:

**FCC OET Bulletin 65 supplement C,
ANSI/IEEE C95.1, C95.3, IEEE 1528-2003**

In the configuration tested, the EUT complied with the standards specified above.

Remarks:

This report details the results of the testing carried out on one sample, the results contained in this test report do not relate to other samples of the same product. The manufacturer should ensure that all products in series production are in conformity with the product sample detailed in this report.

This report may only be reproduced and distributed in full. If the product in this report is used in any configuration other than that detailed in the report, the manufacturer must ensure the new system complies with all relevant standards. Any mention of SGS-CSTC Shanghai GSM Lab or testing done by SGS-CSTC Shanghai GSM Lab must approve SGS Shanghai GSM Lab in connection with distribution or use of the product described in this report in writing.

Tested by :



Date :

2006.07.14

Approved by :

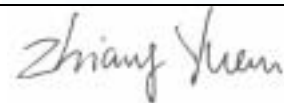

Date :

2006.07.14

Contents

1. General Information	3
1.1 Test Laboratory	3
1.2 Details of Applicant.....	3
1.3 Description of EUT(s)	3
1.4 Test Environment	3
1.5 Operation Configuration.....	3
1.6 The SAR Measurement System	3
1.7 SAR System Verification	3
1.8 Tissue Simulant Fluid for the Frequency Band 850MHz and 1900MHZ.....	3
1.9 Test Standards and Limits	3
2. Summary of Results.....	3
3. Instruments List	3
4. Measurements	3
4.1LeftHandSide-Cheek-GSM850-Low	3
FCC-OET65-LeftHandSide-Cheek-GSM850-Low	3
4.2LeftHandSide-Cheek-GSM850-Middle	3
FCC-OET65-LeftHandSide-Cheek-GSM850-Mid.....	3
4.3LeftHandSide-Cheek-GSM850-High.....	3
FCC-OET65-LeftHandSide-Cheek-GSM850-High	3
4.4LeftHandSide-Tilt-GSM850-Low	3
FCC-OET65-LeftHandSide-Tilt-GSM850-Low	3
4.5LeftHandSide-Tilt-GSM850-Middle.....	3
FCC-OET65-LeftHandSide-Tilt-GSM850-Mid	3
4.6LeftHandSide-Tilt-GSM850-High	3
FCC-OET65-LeftHandSide-Tilt-GSM850-High.....	3
4.7RightHandSide-Cheek-GSM850-Low	3
FCC-OET65-RightHandSide-Cheek-GSM850-Low.....	3
4.8RightHandSide-Cheek-GSM850-Middle.....	3
FCC-OET65-RightHandSide-Cheek-GSM850-Mid	3
4.9RightHandSide-Cheek-GSM850-High	3
FCC-OET65-RightHandSide-Cheek-GSM850-High	3
4.10RightHandSide-Tilt-GSM850-Low	3
FCC-OET65-RightHandSide-Tilt-GSM850-Low	3

4.11RightHandSide-Tilt-GSM850-Middle	3
FCC-OET65-RightHandSide-Tilt-GSM850-Mid.....	3
4.12RightHandSide-Tilt-GSM850-High	3
FCC-OET65-RightHandSide-Tilt-GSM850-High.....	3
4.13Body-Worn-GSM850-GPRS-Low	3
FCC-OET65-Body-Worn-GSM850-GPRS-2cm-Low.....	3
4.14Body-Worn-GSM850-GPRS-Middle.....	3
FCC-OET65-Body-Worn-GSM850-GPRS-2cm-Mid	3
4.15Body-Worn-GSM850-GPRS-High	3
FCC-OET65-Body-Worn-GSM850-GPRS-2cm-High.....	3
4.16LeftHandSide-Cheek-PCS1900-Low	3
FCC-OET65-LeftHandSide-Cheek-PCS1900-Low	3
4.17LeftHandSide-Cheek-PCS1900-Middle	3
FCC-OET65-LeftHandSide-Cheek-PCS1900-Mid	3
4.18LeftHandSide-Cheek-PCS1900-High.....	3
FCC-OET65-LeftHandSide-Cheek-PCS1900-High.....	3
4.19LeftHandSide-Tilt-PCS1900-Low	3
FCC-OET65-LeftHandSide-Tilt-PCS1900-Low	3
4.20LeftHandSide-Tilt-PCS1900-Middle.....	3
FCC-OET65-LeftHandSide-Tilt-PCS1900-Mid.....	3
4.21LeftHandSide-Tilt-PCS1900-High	3
FCC-OET65-LeftHandSide-Tilt-PCS1900-High	3
4.22RightHandSide-Cheek-PCS1900-Low.....	3
FCC-OET65-RightHandSide-Cheek-PCS1900-Low	3
4.23RightHandSide-Cheek-PCS1900-Middle	3
FCC-OET65-RightHandSide-Cheek-PCS1900-Mid.....	3
4.24RightHandSide-Cheek-PCS1900-High.....	3
FCC-OET65-RightHandSide-Cheek-PCS1900-High.....	3
4.25RightHandSide-Tilt-PCS1900-Low	3
FCC-OET65-RightHandSide-Tilt-PCS1900-Low	3
4.26RightHandSide-Tilt-PCS1900-Middle	3
FCC-OET65-RightHandSide-Tilt-PCS1900-Mid	3
4.27RightHandSide-Tilt-PCS1900-High	3
FCC-OET65-RightHandSide-Tilt-PCS1900-High	3
4.28Body-Worn-PCS1900-GPRS-Low.....	3

FCC-OET65-Body-Worn-PCS1900-GPRS-2cm-Low 3

4.29 Body-Worn-PCS1900-GPRS-Middle 3

FCC-OET65-Body-Worn-PCS1900-GPRS-2cm-Mid..... 3

4.30 Body-Worn-PCS1900-GPRS-High 3

FCC-OET65-Body-Worn-PCS1900-GPRS-2cm-High 3

Appendix 3

1. Photographs of Test Setup 3

2. Photographs of the EUT 3

3. Photographs of the battery 3

4. Photograph of the charger 3

5. Probe Calibration certificate 3

6. Uncertainty analysis..... 3

7. Phantom description..... 3

8. System validation from original equipment supplier..... 3

1. General Information

1.1 Test Laboratory

GSM Lab
 SGS-CSTC Standards Technical Services Co.Ltd Shanghai Branch
 9F, the 3rd Building, No.889, Yishan Rd, Xuhui District, Shanghai, China
 Zip code: 200233
 Telephone: +86 (0) 21 6495 1616
 Fax: +86 (0) 21 6495 3679
 Internet: <http://www.cn.sgs.com>

1.2 Details of Applicant

Name: T&A Mobile phones
 Address: 4/F, No.2966, Jinke Rd, Zhangjiang High-Tech Park, Pudong
 Shanghai 201203. P. R. China

1.3 Description of EUT(s)

Brand name	ALCATEL	
Model No.	D6Da	
Market Name	OT-C635a	
Serial No.	IMEI: 01090100000207-8	
Sample Status	Production	
Battery Type	Lithium-Ion	
Antenna Type	Internal Antenna	
Operation Mode	GSM850/PCS1900	
Modulation Mode	GMSK	
Frequency range	GSM850	Tx: 824~849 MHz
		Rx: 869~894 MHz
	PCS1900	Tx: 1850~1910 MHz
		Rx: 1930~1990 MHz
Maximum RF Conducted Power	GSM850: 33dBm, PCS1900: 30dBm	
GPRS	Multi-Slot Class 10 uplink 2TS	

1.4 Test Environment

Ambient temperature: 22.0° C

Tissue Simulating Liquid: 22° C

Relative Humidity: 49%~55%

1.5 Operation Configuration

Configuration 1: GSM 850, LeftHandSide Cheek & 15 ° Tilt Position

Configuration 2: GSM 850, RightHandSide Cheek & 15 ° Tilt Position

Configuration 3: GSM 850, BodyWorn (2.0 cm between EUT and phantom)

Configuration 4: PCS 1900, LeftHandSide Cheek & 15 ° Tilt Position

Configuration 5: PCS 1900, RightHandSide Cheek & 15 ° Tilt Position

Configuration 6: PCS 1900, BodyWorn (2.0 cm between EUT and phantom)

1.6 The SAR Measurement System

A photograph of the SAR measurement System is given in Fig.a.

This SAR Measurement System uses a Computer-controlled 3-D stepper motor system (Speag Dasy 4 professional system). A Model ES3DV3 3088 E-field probe is used to determine the internal electric fields. The SAR can be obtained from the equation $SAR = \sigma (|E_i|^2) / \rho$ where σ and ρ are the conductivity and mass density of the tissue-simulant.

The DASY4 system for performing compliance tests consists of the following items:

- A standard high precision 6-axis robot (Stabile RX family) with controller, teach pendant and software. An arm extension for accommodation the data acquisition electronics (DAE).
- A dosimetric probe, i.e., an isotropic E-field probe optimized and calibrated for usage in tissue simulating liquid. The probe is equipped with an optical surface detector system.
- A data acquisition electronics (DAE) which performs the signal amplification, signal multiplexing, AD-conversion, offset measurements, mechanical surface detection, collision detection, etc. The unit is battery powered with standard or rechargeable batteries. The signal is optically transmitted to the EOC.

- The Electro-optical converter (EOC) performs the conversion between optical and electrical of the signals for the digital communication to DAE and for the analog signal from the optical surface detection. The EOC is connected to the measurement server.

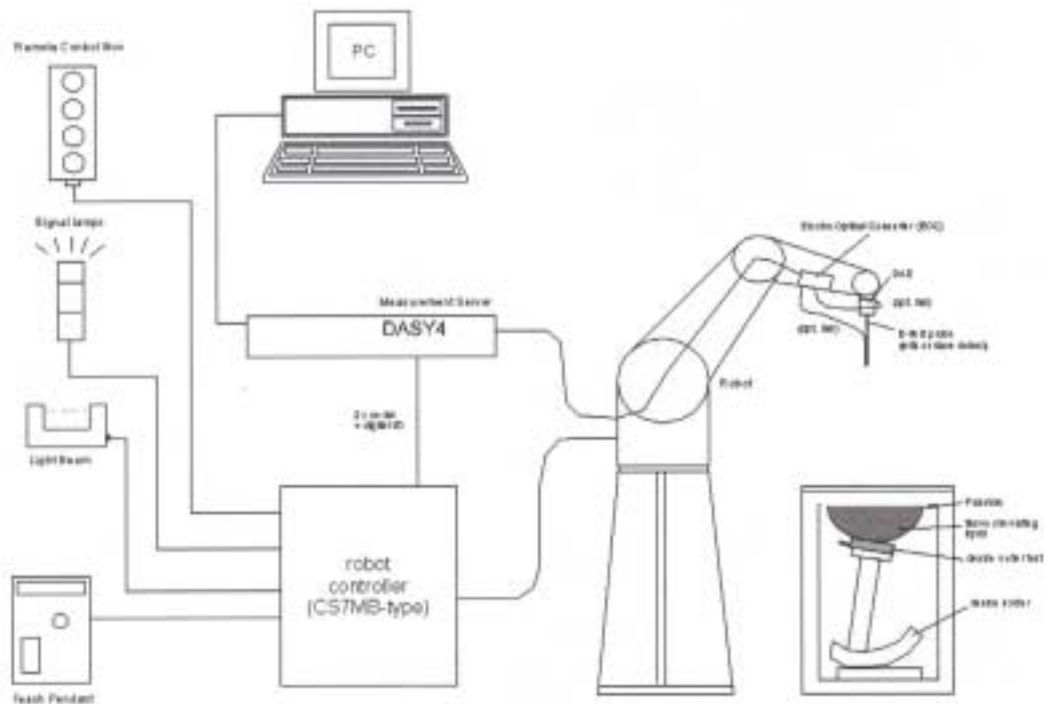

Fig. a SAR System Configuration

- The function of the measurement server is to perform the time critical tasks such as signal filtering, control of the robot operation and fast movement interrupts.
- A probe alignment unit which improves the (absolute) accuracy of the probe positioning.
- A computer operating Windows 2000.
- DASY4 software.
- Remote control with teach pendant and additional circuitry for robot safety such as warning lamps, etc.
- The SAM twin phantom enabling testing left-hand, right-hand and body-worn usage.
- The device holder for handheld mobile phones.
- Tissue simulating liquid mixed according to the given recipes.

- Validation dipole kits allowing to validating the proper functioning of the system.

1.7 SAR System Verification

The microwave circuit arrangement for system verification is sketched in Fig. b. The daily system accuracy verification occurs within the flat section of the SAM phantom. A SAR measurement was performed to see if the measured SAR was within +/- 10% from the target SAR values. These tests were done at 900MHz and 1900MHz. The tests were conducted on the same days as the measurement of the DUT. The obtained results from the system accuracy verification are displayed in the table 1 (SAR values are normalized to 1W forward power delivered to the dipole). During the tests, the ambient temperature of the laboratory was in the range 22°C, the relative humidity was in the range 60% and the liquid depth above the ear reference points was above 15 cm in all the cases. It is seen that the system is operating within its specification, as the results are within acceptable tolerance of the reference values.

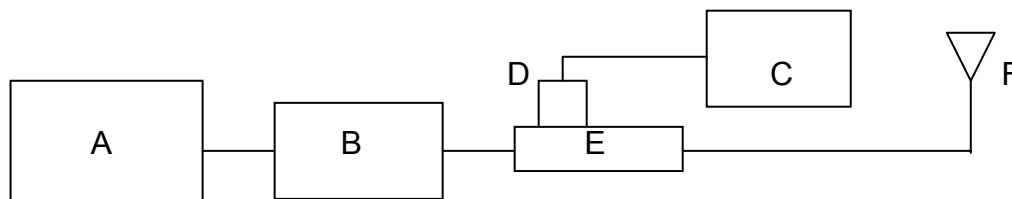

Fig. b the microwave circuit arrangement used for SAR system verification

- A. Agilent Model E4438C Signal Generator
- B. Mini-Circuit Model ZHL-42 Preamplifier
- C. Agilent Model E4416A Power Meter
- D. Agilent Model 8481H Power Sensor
- E. HT CP6100 20N Dual directional coupler
- F. Reference dipole antenna

Validation Kit	Frequency MHz	Target SAR 1g (250mW)	Target SAR 10g (250mW)	Measured SAR 1g	Measured SAR 10g	Measured Date
ES3DV3 SN3088	900 Head	2.6	1.67	2.63	1.65	2006-07-06
ES3DV3 SN3088	900 Body	2.69	1.74	2.67	1.71	2006-07-06
ES3DV3 SN3088	1900 Head	9.89	5.16	9.72	5.11	2006-07-10
ES3DV3 SN3088	1900 Body	9.81	5.22	9.69	5.17	2006-07-13

Table 1. Result System Validation

1.8 Tissue Simulant Fluid for the Frequency Band 900MHz and 1900MHz

The dielectric properties for this body-simulant fluid were measured by using the HP Model 85070D Dielectric Probe (rates frequency band 200 MHz to 20 GHz) in conjunction with Agilent E5071B Network Analyzer (300 KHz-8500 MHz). The Conductivity (σ) and Permittivity (ρ) are listed in Table 2. For the SAR measurement given in this report. The temperature variation of the Tissue Simulant Fluid was 22°C.

Frequency (MHz)	Tissue Type	Limit/Measured	Permittivity (ρ)	Conductivity (σ)	Simulated Tissue Temp (°C)
900	Head	Measured, 2006-07-06	42.06	0.939	22.5
		Recommended Limit	41.5±5%	0.97±5%	20-24
	Body	Measured, 2006-07-06	52.44	1.007	22.5
		Recommended Limit	55.0±5%	1.05±5%	20-24
1900	Head	Measured, 2006-07-10	40.21	1.460	22.3
		Recommended Limit	40.0±5%	1.40±5%	20-24
	Body	Measured, 2006-07-13	51.55	1.464	22.6
		Recommended Limit	53.3±5%	1.52±5%	20-24

Table 2. Dielectric parameters for the Frequency Band 900MHz&1900MHZ

1.9 Test Standards and Limits

According to FCC 47 CFR §2.1093(d) the limits to be used for evaluation are based generally on criteria published by the American National Standards Institute (ANSI) for localized specific absorption rate (SAR) in Section 4.2 of "IEEE Standard for Safety Levels with Respect to Human Exposure to Radio Frequency Electromagnetic Fields, 3KHz to 300GHz," ANSI/IEEE C95.1-1992, Copyright 1992 by the Institute of Electrical & Electronics Engineers, Inc., New York, New York 10071.

Human Exposure	Uncontrolled Environment General Population
Spatial Peak SAR (Brain)	1.60 mW/g (averaged over a mass of 1g)

Table 3. RF Exposure Limits

Notes:

1. Uncontrolled environments are defined as locations where there is potential exposure of the individuals who have no knowledge or control of their potential exposure.

2. Summary of Results

Frequency Band(MHz)	EUT position	Conducted Output Power (dBm)	1g Avg. (mW/g)	10g Avg. (mW/g)	Power Drift (dB)	Amb. Temp ()	Verdict
GSM 850	LeftHandSide Cheek, Low Channel	32.0	0.497	0.335	-0.094	22	PASS
	LeftHandSide Cheek, Mid Channel	31.9	0.703	0.474	0.005	22	PASS
	LeftHandSide Cheek, High Channel	31.8	1.16	0.776	-0.088	22	PASS
	LeftHandSide Tilt, Low Channel	32.0	0.183	0.131	0.016	22	PASS
	LeftHandSide Tilt, Mid Channel	31.9	0.266	0.190	-0.063	22	PASS
	LeftHandSide Tilt, High Channel	31.8	0.454	0.324	0.029	22	PASS
	RightHandSide Cheek, Low Channel	32.0	0.570	0.383	0.183	22	PASS
	RightHandSide Cheek, Mid Channel	31.9	0.820	0.551	0.017	22	PASS
	RightHandSide Cheek, High Channel	31.8	1.34	0.890	-0.011	22	PASS
	RightHandSide Tilt, Low Channel	32.0	0.190	0.136	0.016	22	PASS
	RightHandSide Tilt, Mid Channel	31.9	0.266	0.191	-0.002	22	PASS
	RightHandSide Tilt, High Channel	31.8	0.462	0.329	-0.001	22	PASS
GSM 850	GPRS,BodyWorn, Low Channel	32.0	0.165	0.121	0.139	22	PASS
	GPRS,BodyWorn, Mid Channel	31.9	0.204	0.149	0.019	22	PASS
	GPRS,BodyWorn, High Channel	31.8	0.372	0.236	0.016	22	PASS
PCS 1900	LeftHandSide Cheek, Low Channel	29.0	0.283	0.171	-0.342	22	PASS
	LeftHandSide Cheek, Mid Channel	28.8	0.287	0.172	0.175	22	PASS
	LeftHandSide Cheek, High Channel	28.9	0.301	0.179	-0.071	22	PASS
	LeftHandSide Tilt, Low Channel	29.0	0.052	0.031	-0.050	22	PASS
	LeftHandSide Tilt, Mid Channel	28.8	0.052	0.029	-0.070	22	PASS
	LeftHandSide Tilt, High Channel	28.9	0.046	0.025	0.005	22	PASS

	RightHandSide Cheek, Low Channel	29.0	0.322	0.192	-0.239	22	PASS
	RightHandSide Cheek, Mid Channel	28.8	0.341	0.201	-0.140	22	PASS
	RightHandSide Cheek, High Channel	28.9	0.346	0.204	-0.058	22	PASS
	RightHandSide Tilt, Low Channel	29.0	0.056	0.032	-0.133	22	PASS
	RightHandSide Tilt, Mid Channel	28.8	0.057	0.032	-0.080	22	PASS
	RightHandSide Tilt, High Channel	28.9	0.050	0.027	-0.044	22	PASS
PCS 1900	GPRS,BodyWorn, Low Channel	29.0	0.595	0.360	-0.250	22	PASS
	GPRS,BodyWorn, Mid Channel	28.8	0.562	0.337	-0.109	22	PASS
	GPRS,BodyWorn, High Channel	28.9	0.412	0.246	-0.023	22	PASS

Maximum Values

Frequency Band(MHz)	EUT position	Conducted Output Power (dBm)	1g Average (W/Kg)	10g Average (W/Kg)	Power Drift (dB)	Amb. Temp ()	Verdict
GSM850	LeftHandSide Cheek, High Channel	31.8	1.16	0.776	-0.088	22	PASS
	RightHandSide Cheek, High Channel	31.8	1.34	0.890	-0.011	22	PASS
	GPRS,BodyWorn, High Channel	31.8	0.372	0.236	0.016	22	PASS
PCS1900	LeftHandSide Cheek, High Channel	28.9	0.301	0.179	-0.071	22	PASS
	RightHandSide Tilt, Mid Channel	28.9	0.346	0.204	-0.058	22	PASS
	GPRS,BodyWorn, Low Channel	29.0	0.595	0.360	-0.250	22	PASS

Note:

1. In GSM850 band, the low, middle and high channels are CH128/824.2MHz, CH189/836.4MHz and CH251/848.8MHz separately.
2. In PCS1900 band, the low, middle and high channels are CH512/1805.2MHz, CH661/1880.0MHz and CH810/1909.8MHz separately.
3. For the Bodyworn measurements the sample was only placed with the antenna toward the phantom since this position delivers the highest SAR values.
4. For the Bodyworn measurements, the distance from the sample to the phantom is 2.0 cm.

3. Instruments List

Instrument	Model	Serial number	NO.	Date of last Calibration
Desktop PC	COMPAQ EVO	N/A	GSM-SAR-025	N/A
Dasy 4 software	V 4.6 build 23	N/A	GSM-SAR-001	N/A
Probe	ES3DV3	3088	GSM-SAR-034	2005.09.13
DAE	DAE3	569	GSM-SAR-023	2005.11.17
Phantom	SAM 12	TP-1283	GSM-SAR-005	N/A
Robot	RX90L	F03/5V32A1/A01	GSM-SAR-008	N/A
900MHz system validation dipole	D900V2	184	GSM-SAR-013	2005.8.22
1900MHz system validation dipole	D1900V2	5d028	GSM-SAR-020	2005.8.25
Dielectric probe kit	85070D	US01440168	GSM-SAR-016	2005.12.19
Agilent network analyzer	E5071B	MY42100549	GSM-SAR-007	2005.12.19
Agilent signal generator	E4438	14438CATO-19719	GSM-SAR-008	2005.12.19
Mini-Circuits preamplifier	ZHL-42	D041905	GSM-SAR-033	2006.04.19
Agilent power meter	E4416A	GB41292095	GSM-SAR-010	2005.12.19
Agilent power sensor	8481H	MY41091234	GSM-SAR-011	2005.12.19
HT CP6100 20N Coupling	6100	SCP301480120	GSM-SAR-012	2005.12.19
R&S Universal radio communication tester	CMU200	103633	GSM-AUD-002	2005.12.20

4. Measurements

4.1 LeftHandSide-Cheek-GSM850-Low

Date/Time: 2006-7-7 15:26:04

Test Laboratory: SGS-GSM

FCC-OET65-LeftHandSide-Cheek-GSM850-Low

DUT: GSM10006708M; Type: Head; Serial: 01090100000207-8

Communication System: GSM850-GSM Mode; Frequency: 824.2 MHz; Duty Cycle: 1:8.3

Medium: HSL850-Head Medium parameters used: $f = 824.2$ MHz; $\epsilon = 0.882$ mho/m; $r = 42.4$; $\rho = 1000$ kg/m³

Phantom section: Left Section

Measurement Standard: DAS4 (High Precision Assessment)

DASY4 Configuration:

- Probe: ES3DV3 - SN3088; ConvF(5.91, 5.91, 5.91); Calibrated: 2005-9-13
- Sensor-Surface: 4mm (Mechanical Surface Detection)
- Electronics: DAE3 Sn569; Calibrated: 2005-11-17
- Phantom: SAM 12; Type: SAM V4.0; Serial: TP-1283
- Measurement SW: DAS4, V4.6 Build 23; Postprocessing SW: SEMCAD, V1.8 Build 160

Cheek position - Low/Area Scan (61x101x1): Measurement grid: dx=15mm, dy=15mm

Maximum value of SAR (interpolated) = 0.536 mW/g

Cheek position - Low/Zoom Scan (7x7x7)/Cube 0: Measurement grid: dx=5mm, dy=5mm, dz=5mm

Reference Value = 9.08 V/m; Power Drift = -0.094 dB

Peak SAR (extrapolated) = 0.708 W/kg

SAR(1 g) = 0.497 mW/g; SAR(10 g) = 0.335 mW/g

Maximum value of SAR (measured) = 0.534 mW/g

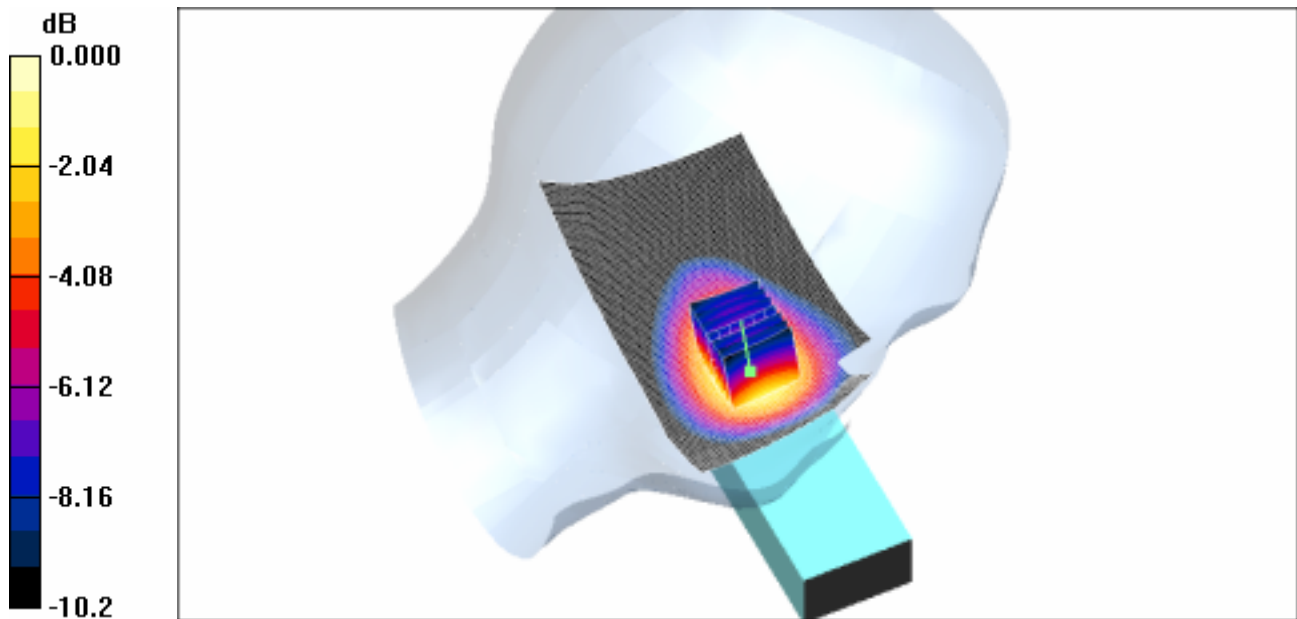

0 dB = 0.534mW/g

4.2 LeftHandSide-Cheek-GSM850-Middle

Date/Time: 2006-7-7 15:51:47

Test Laboratory: SGS-GSM

FCC-OET65-LeftHandSide-Cheek-GSM850-Mid

DUT: GSM10006708M ; Type: Head; Serial: 01090100000207-8

Communication System: GSM850-GSM Mode; Frequency: 836.4 MHz; Duty Cycle: 1:8.3

Medium: HSL850-Head Medium parameters used: $f = 836.4 \text{ MHz}$; $\sigma = 0.901 \text{ mho/m}$; $\epsilon_r = 42.2$; $\rho = 1000 \text{ kg/m}^3$

Phantom section: Left Section

Measurement Standard: DASY4 (High Precision Assessment)

DASY4 Configuration:

- Probe: ES3DV3 - SN3088; ConvF(5.91, 5.91, 5.91); Calibrated: 2005-9-13
- Sensor-Surface: 4mm (Mechanical Surface Detection)
- Electronics: DAE3 Sn569; Calibrated: 2005-11-17

- Phantom: SAM 12; Type: SAM V4.0; Serial: TP-1283
- Measurement SW: DASY4, V4.6 Build 23; Postprocessing SW: SEMCAD, V1.8 Build 160

Cheek position - Mid/Area Scan (61x101x1): Measurement grid: dx=15mm, dy=15mm

Maximum value of SAR (interpolated) = 0.773 mW/g

Cheek position - Mid/Zoom Scan (7x7x7) (7x7x7)/Cube 0: Measurement grid: dx=5mm, dy=5mm, dz=5mm

Reference Value = 10.6 V/m; Power Drift = 0.005 dB

Peak SAR (extrapolated) = 0.983 W/kg

SAR(1 g) = 0.703 mW/g; SAR(10 g) = 0.474 mW/g

Maximum value of SAR (measured) = 0.759 mW/g

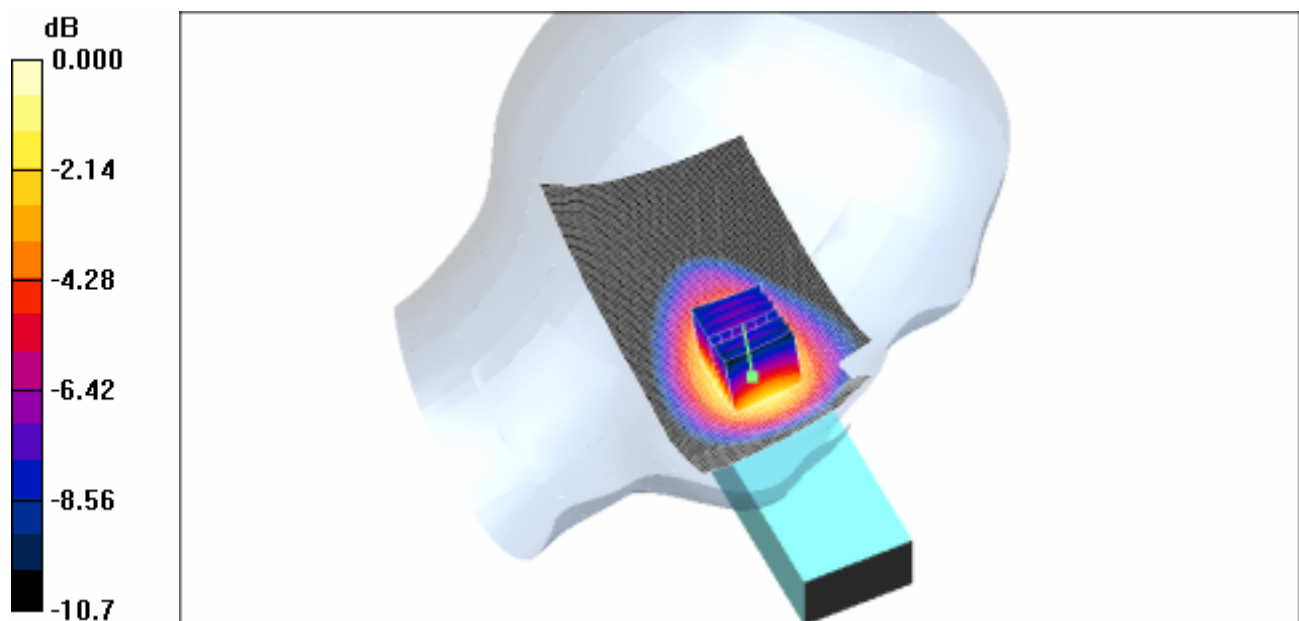

4.3LeftHandSide-Cheek-GSM850-High

Date/Time: 2006-7-7 16:17:27

Test Laboratory: SGS-GSM

FCC-OET65-LeftHandSide-Cheek-GSM850-High

DUT: GSM10006708M; Type: Head; Serial: 01090100000207-8

Communication System: GSM850-GSM Mode; Frequency: 848.8 MHz; Duty Cycle: 1:8.3

Medium: HSL850-Head Medium parameters used: $f = 848.8$ MHz; $\mu = 0.921$ mho/m; $\rho = 42.2$; $\rho = 1000$ kg/m³

Phantom section: Left Section

Measurement Standard: DASY4 (High Precision Assessment)

DASY4 Configuration:

- Probe: ES3DV3 - SN3088; ConvF(5.91, 5.91, 5.91); Calibrated: 2005-9-13
- Sensor-Surface: 4mm (Mechanical Surface Detection)
- Electronics: DAE3 Sn569; Calibrated: 2005-11-17
- Phantom: SAM 12; Type: SAM V4.0; Serial: TP-1283
- Measurement SW: DASY4, V4.6 Build 23; Postprocessing SW: SEMCAD, V1.8 Build 160

Cheek position - High/Area Scan (61x101x1): Measurement grid: dx=15mm, dy=15mm

Maximum value of SAR (interpolated) = 1.27 mW/g

Cheek position - High/Zoom Scan (7x7x7) (7x7x7)/Cube 0: Measurement grid: dx=5mm, dy=5mm, dz=5mm

Reference Value = 13.7 V/m; Power Drift = -0.088 dB

Peak SAR (extrapolated) = 1.65 W/kg

SAR(1 g) = 1.16 mW/g; SAR(10 g) = 0.776 mW/g

Maximum value of SAR (measured) = 1.26 mW/g

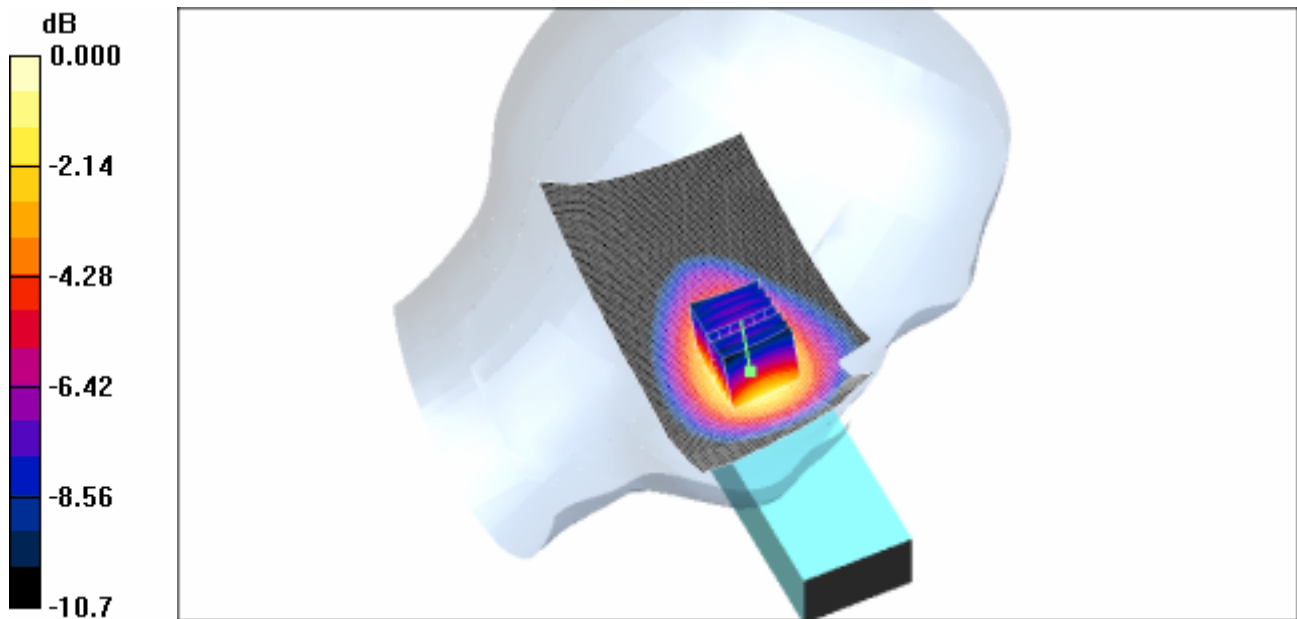

0 dB = 1.26mW/g

4.4 LeftHandSide-Tilt-GSM850-Low

Date/Time: 2006-7-7 16:47:47

Test Laboratory: SGS-GSM

FCC-OET65-LeftHandSide-Tilt-GSM850-Low

DUT: GSM10006708M; Type: Head; Serial: 01090100000207-8

Communication System: GSM850-GSM Mode; Frequency: 824.2 MHz; Duty Cycle: 1:8.3

Medium: HSL850-Head Medium parameters used: $f = 824.2 \text{ MHz}$; $\sigma = 0.882 \text{ mho/m}$; $\epsilon_r = 42.4$; $\rho = 1000 \text{ kg/m}^3$

Phantom section: Left Section

Measurement Standard: DASY4 (High Precision Assessment)

DASY4 Configuration:

- Probe: ES3DV3 - SN3088; ConvF(5.91, 5.91, 5.91); Calibrated: 2005-9-13
- Sensor-Surface: 4mm (Mechanical Surface Detection)
- Electronics: DAE3 Sn569; Calibrated: 2005-11-17

- Phantom: SAM 12; Type: SAM V4.0; Serial: TP-1283
- Measurement SW: DASY4, V4.6 Build 23; Postprocessing SW: SEMCAD, V1.8 Build 160

Tilt position - Low/Area Scan (61x101x1): Measurement grid: dx=15mm, dy=15mm

Maximum value of SAR (interpolated) = 0.195 mW/g

Tilt position - Low/Zoom Scan (7x7x7)/Cube 0: Measurement grid: dx=5mm, dy=5mm, dz=5mm

Reference Value = 11.4 V/m; Power Drift = 0.016 dB

Peak SAR (extrapolated) = 0.241 W/kg

SAR(1 g) = 0.183 mW/g; SAR(10 g) = 0.131 mW/g

Maximum value of SAR (measured) = 0.194 mW/g

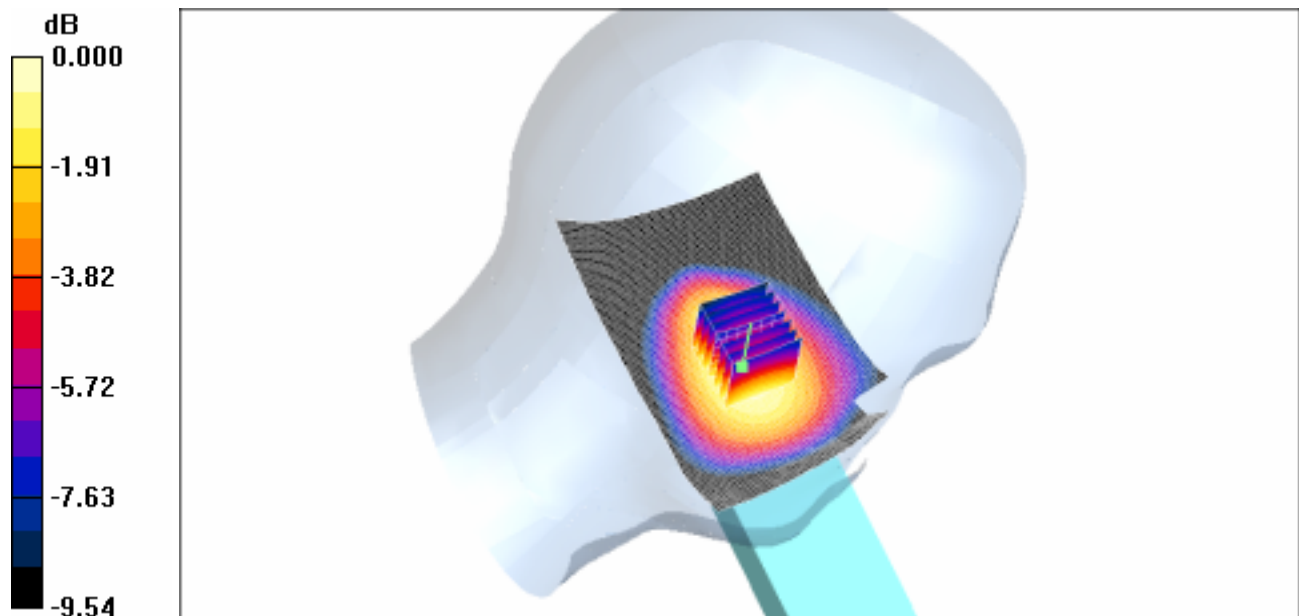

0 dB = 0.194mW/g

4.5LeftHandSide-Tilt-GSM850-Middle

Date/Time: 2006-7-10 8:29:15

Test Laboratory: SGS-GSM

FCC-OET65-LeftHandSide-Tilt-GSM850-Mid

DUT: GSM10006708M; Type: Head; Serial: 01090100000207-8

Communication System: GSM850-GSM Mode; Frequency: 836.4 MHz; Duty Cycle: 1:8.3

Medium: HSL850-Head Medium parameters used: $f = 836.4$ MHz; $\sigma = 0.901$ mho/m; $\epsilon_r = 42.2$; $\rho = 1000$ kg/m³

Phantom section: Left Section

Measurement Standard: DAS4 (High Precision Assessment)

DASY4 Configuration:

- Probe: ES3DV3 - SN3088; ConvF(5.91, 5.91, 5.91); Calibrated: 2005-9-13
- Sensor-Surface: 4mm (Mechanical Surface Detection)
- Electronics: DAE3 Sn569; Calibrated: 2005-11-17
- Phantom: SAM 12; Type: SAM V4.0; Serial: TP-1283
- Measurement SW: DAS4, V4.6 Build 23; Postprocessing SW: SEMCAD, V1.8 Build 160

Tilt position - Middle/Area Scan (61x101x1): Measurement grid: dx=15mm, dy=15mm

Maximum value of SAR (interpolated) = 0.283 mW/g

Tilt position - Middle/Zoom Scan (7x7x7) (7x7x7)/Cube 0: Measurement grid: dx=5mm, dy=5mm, dz=5mm

Reference Value = 13.7 V/m; Power Drift = -0.063 dB

Peak SAR (extrapolated) = 0.352 W/kg

SAR(1 g) = 0.266 mW/g; SAR(10 g) = 0.190 mW/g

Maximum value of SAR (measured) = 0.284 mW/g

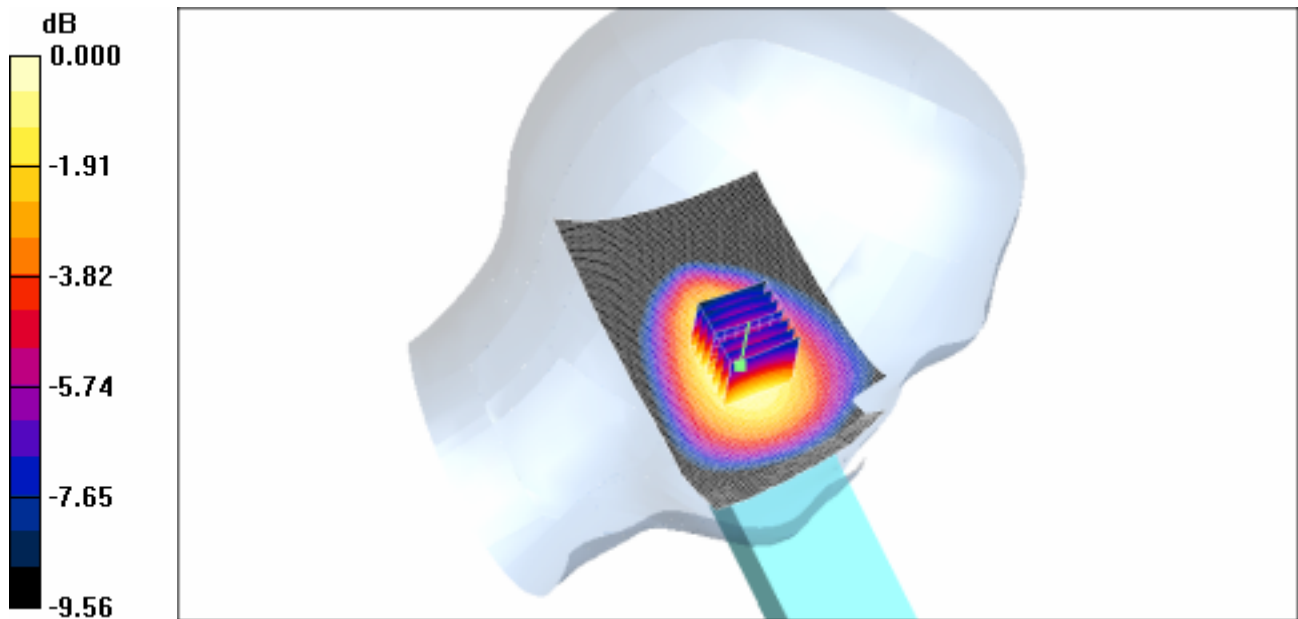

0 dB = 0.284mW/g

4.6LeftHandSide-Tilt-GSM850-High

Date/Time: 2006-7-10 8:55:12

Test Laboratory: SGS-GSM

FCC-OET65-LeftHandSide-Tilt-GSM850-High

DUT: GSM10006708M; Type: Head; Serial: 01090100000207-8

Communication System: GSM850-GSM Mode; Frequency: 848.8 MHz;Duty Cycle: 1:8.3

Medium: HSL850-Head Medium parameters used: $f = 848.8$ MHz; $\sigma = 0.921$ mho/m; $\epsilon_r = 42.2$; $\rho = 1000$ kg/m³

Phantom section: Left Section

Measurement Standard: DASY4 (High Precision Assessment)

DASY4 Configuration:

- Probe: ES3DV3 - SN3088; ConvF(5.91, 5.91, 5.91); Calibrated: 2005-9-13
- Sensor-Surface: 4mm (Mechanical Surface Detection)
- Electronics: DAE3 Sn569; Calibrated: 2005-11-17

- Phantom: SAM 12; Type: SAM V4.0; Serial: TP-1283
- Measurement SW: DASY4, V4.6 Build 23; Postprocessing SW: SEMCAD, V1.8 Build 160

Tilt position - High/Area Scan (61x101x1): Measurement grid: dx=15mm, dy=15mm

Maximum value of SAR (interpolated) = 0.488 mW/g

Tilt position - High/Zoom Scan (7x7x7) (7x7x7)/Cube 0: Measurement grid: dx=5mm, dy=5mm,

dz=5mm

Reference Value = 17.6 V/m; Power Drift = 0.029 dB

Peak SAR (extrapolated) = 0.606 W/kg

SAR(1 g) = 0.454 mW/g; SAR(10 g) = 0.324 mW/g

Maximum value of SAR (measured) = 0.488 mW/g

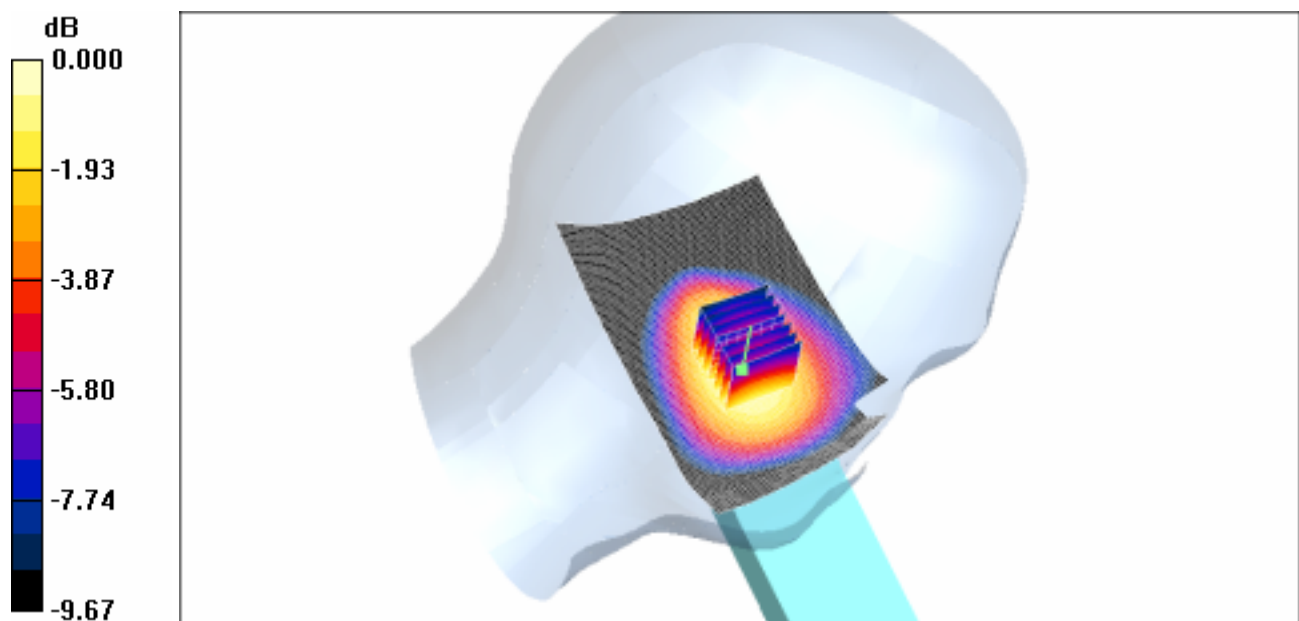

0 dB = 0.488mW/g

4.7RightHandSide-Cheek-GSM850-Low

Date/Time: 2006-7-7 11:37:00

Test Laboratory: SGS-GSM

FCC-OET65-RightHandSide-Cheek-GSM850-Low

DUT: GSM10006708M; Type: Head; Serial: 01090100000207-8

Communication System: GSM850-GSM Mode; Frequency: 824.2 MHz; Duty Cycle: 1:8.3

Medium: HSL850-Head Medium parameters used: $f = 824.2$ MHz; $\mu = 0.882$ mho/m; $\rho = 42.4$; $\rho = 1000$ kg/m³

Phantom section: Right Section

Measurement Standard: DASY4 (High Precision Assessment)

DASY4 Configuration:

- Probe: ES3DV3 - SN3088; ConvF(5.91, 5.91, 5.91); Calibrated: 2005-9-13
- Sensor-Surface: 4mm (Mechanical Surface Detection)
- Electronics: DAE3 Sn569; Calibrated: 2005-11-17
- Phantom: SAM 12; Type: SAM V4.0; Serial: TP-1283
- Measurement SW: DASY4, V4.6 Build 23; Postprocessing SW: SEMCAD, V1.8 Build 160

Cheek position - Low/Area Scan (61x101x1): Measurement grid: dx=15mm, dy=15mm

Maximum value of SAR (interpolated) = 0.609 mW/g

Cheek position - Low/Zoom Scan (7x7x7) (7x7x7)/Cube 0: Measurement grid: dx=5mm, dy=5mm, dz=5mm

Reference Value = 7.99 V/m; Power Drift = 0.183 dB

Peak SAR (extrapolated) = 0.806 W/kg

SAR(1 g) = 0.570 mW/g; SAR(10 g) = 0.383 mW/g

Maximum value of SAR (measured) = 0.614 mW/g

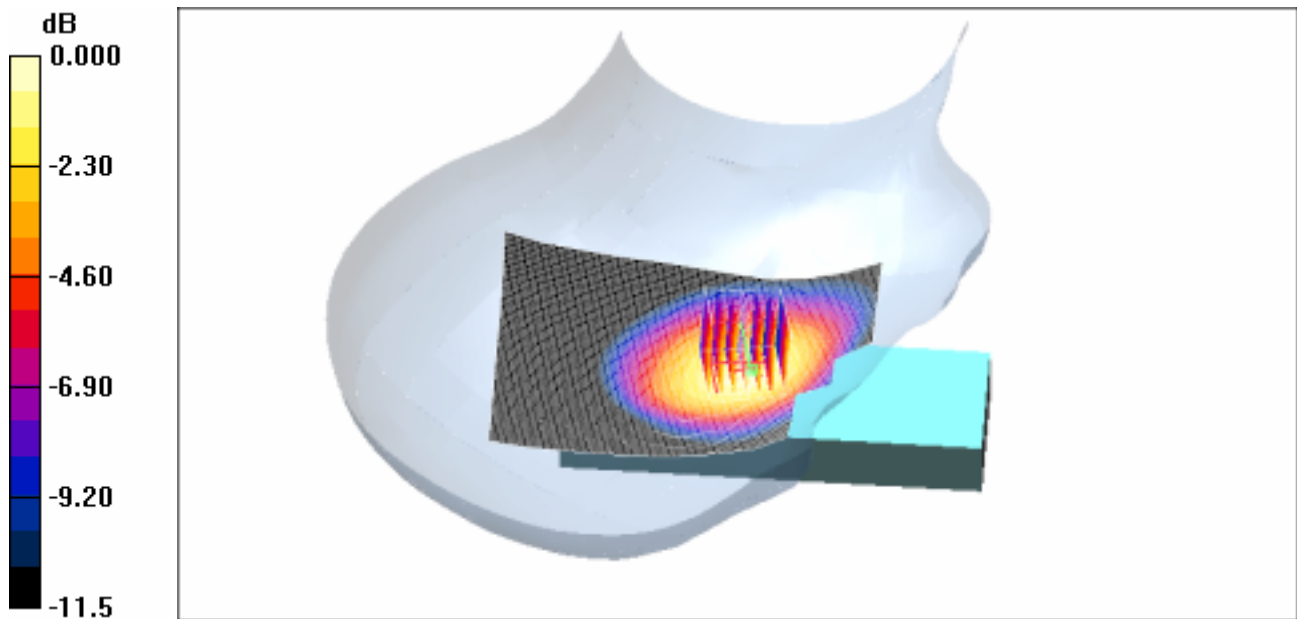

0 dB = 0.614mW/g

4.8RightHandSide-Cheek-GSM850-Middle

Date/Time: 2006-7-7 12:11:34

Test Laboratory: SGS-GSM

FCC-OET65-RightHandSide-Cheek-GSM850-Mid

DUT: GSM10006708M; Type: Head; Serial: 01090100000207-8

Communication System: GSM850-GSM Mode; Frequency: 836.4 MHz; Duty Cycle: 1:8.3

Medium: HSL850-Head Medium parameters used: $f = 836.4 \text{ MHz}$; $\sigma = 0.901 \text{ mho/m}$; $\epsilon_r = 42.2$; $\rho = 1000 \text{ kg/m}^3$

Phantom section: Right Section

Measurement Standard: DASY4 (High Precision Assessment)

DASY4 Configuration:

- Probe: ES3DV3 - SN3088; ConvF(5.91, 5.91, 5.91); Calibrated: 2005-9-13
- Sensor-Surface: 4mm (Mechanical Surface Detection)
- Electronics: DAE3 Sn569; Calibrated: 2005-11-17

- Phantom: SAM 12; Type: SAM V4.0; Serial: TP-1283
- Measurement SW: DASY4, V4.6 Build 23; Postprocessing SW: SEMCAD, V1.8 Build 160

Cheek position - Middle/Area Scan (61x101x1): Measurement grid: dx=15mm, dy=15mm

Maximum value of SAR (interpolated) = 0.877 mW/g

Cheek position - Middle/Zoom Scan (7x7x7)/Cube 0: Measurement grid: dx=5mm, dy=5mm,

dz=5mm

Reference Value = 9.71 V/m; Power Drift = 0.017 dB

Peak SAR (extrapolated) = 1.15 W/kg

SAR(1 g) = 0.820 mW/g; SAR(10 g) = 0.551 mW/g

Maximum value of SAR (measured) = 0.875 mW/g

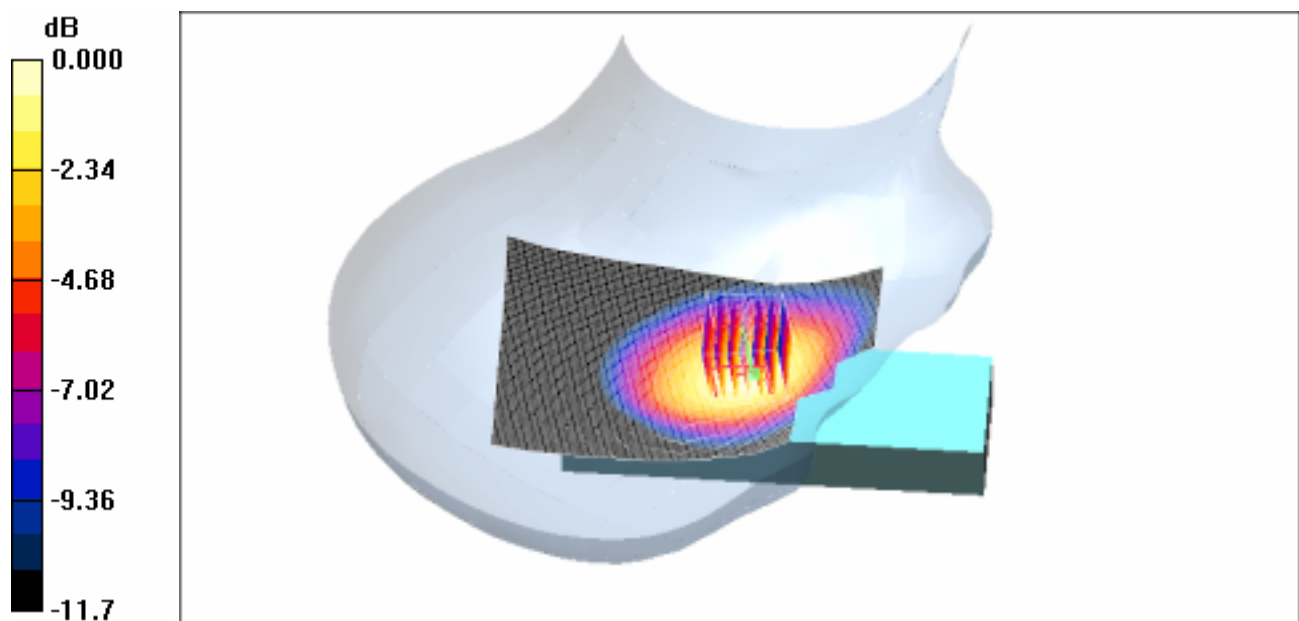

0 dB = 0.875mW/g

4.9RightHandSide-Cheek-GSM850-High

Date/Time: 2006-7-7 12:58:14

Test Laboratory: SGS-GSM

FCC-OET65-RightHandSide-Cheek-GSM850-High

DUT: GSM10006708M; Type: Head; Serial: 01090100000207-8

Communication System: GSM850-GSM Mode; Frequency: 848.8 MHz; Duty Cycle: 1:8.3

Medium: HSL850-Head Medium parameters used: $f = 848.8$ MHz; $\mu = 0.921$ mho/m; $\rho = 42.2$; $\rho = 1000$ kg/m³

Phantom section: Right Section

Measurement Standard: DASY4 (High Precision Assessment)

DASY4 Configuration:

- Probe: ES3DV3 - SN3088; ConvF(5.91, 5.91, 5.91); Calibrated: 2005-9-13
- Sensor-Surface: 4mm (Mechanical Surface Detection)
- Electronics: DAE3 Sn569; Calibrated: 2005-11-17
- Phantom: SAM 12; Type: SAM V4.0; Serial: TP-1283
- Measurement SW: DASY4, V4.6 Build 23; Postprocessing SW: SEMCAD, V1.8 Build 160

Cheek position - High/Area Scan (61x101x1): Measurement grid: dx=15mm, dy=15mm

Maximum value of SAR (interpolated) = 1.43 mW/g

Cheek position - High/Zoom Scan (7x7x7) (7x7x7)/Cube 0: Measurement grid: dx=5mm, dy=5mm, dz=5mm

Reference Value = 12.3 V/m; Power Drift = -0.011 dB

Peak SAR (extrapolated) = 1.92 W/kg

SAR(1 g) = 1.34 mW/g; SAR(10 g) = 0.890 mW/g

Maximum value of SAR (measured) = 1.44 mW/g

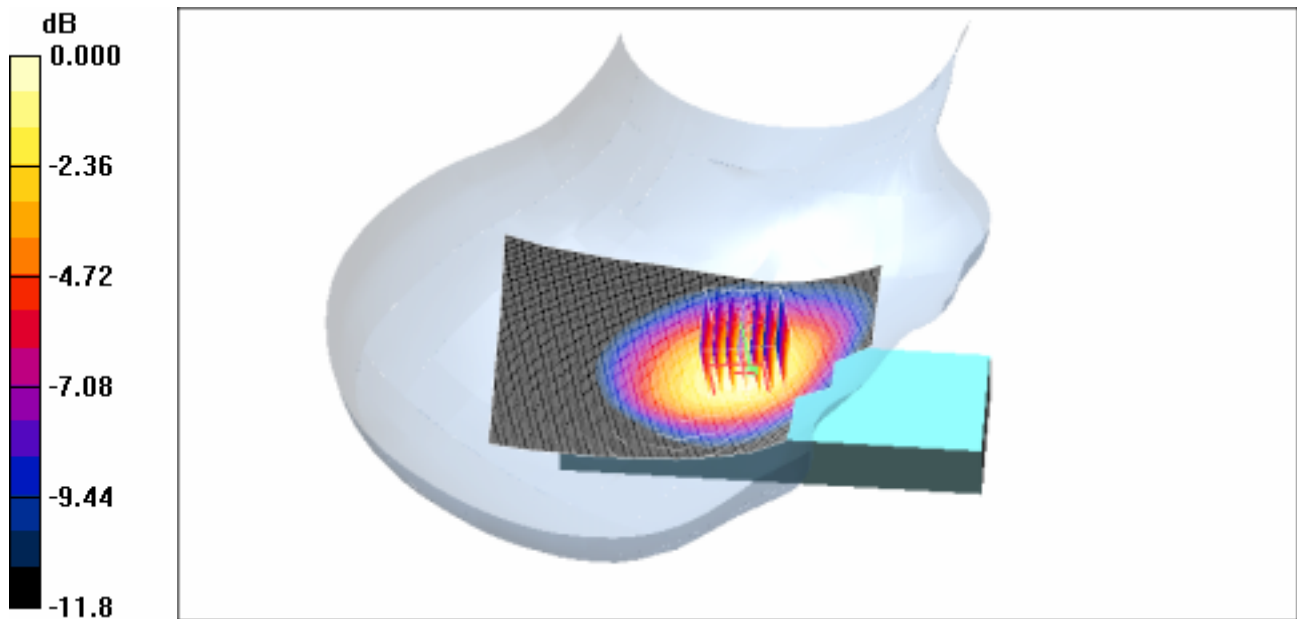

0 dB = 1.44mW/g

4.10 RightHandSide-Tilt-GSM850-Low

Date/Time: 2006-7-7 13:51:19

Test Laboratory: SGS-GSM

FCC-OET65-RightHandSide-Tilt-GSM850-Low

DUT: GSM10006708M; Type: Head; Serial: 01090100000207-8

Communication System: GSM850-GSM Mode; Frequency: 824.2 MHz; Duty Cycle: 1:8.3

Medium: HSL850-Head Medium parameters used: $f = 824.2$ MHz; $\sigma = 0.882$ mho/m; $\epsilon_r = 42.4$; $\rho = 1000$ kg/m³

Phantom section: Right Section

Measurement Standard: DASY4 (High Precision Assessment)

DASY4 Configuration:

- Probe: ES3DV3 - SN3088; ConvF(5.91, 5.91, 5.91); Calibrated: 2005-9-13
- Sensor-Surface: 4mm (Mechanical Surface Detection)
- Electronics: DAE3 Sn569; Calibrated: 2005-11-17

- Phantom: SAM 12; Type: SAM V4.0; Serial: TP-1283
- Measurement SW: DASY4, V4.6 Build 23; Postprocessing SW: SEMCAD, V1.8 Build 160

Tilt position - Low/Area Scan (61x101x1): Measurement grid: dx=15mm, dy=15mm

Maximum value of SAR (interpolated) = 0.202 mW/g

Tilt position - Low/Zoom Scan (7x7x7) (7x7x7)/Cube 0: Measurement grid: dx=5mm, dy=5mm, dz=5mm

Reference Value = 11.2 V/m; Power Drift = 0.016 dB

Peak SAR (extrapolated) = 0.249 W/kg

SAR(1 g) = 0.190 mW/g; SAR(10 g) = 0.136 mW/g

Maximum value of SAR (measured) = 0.201 mW/g

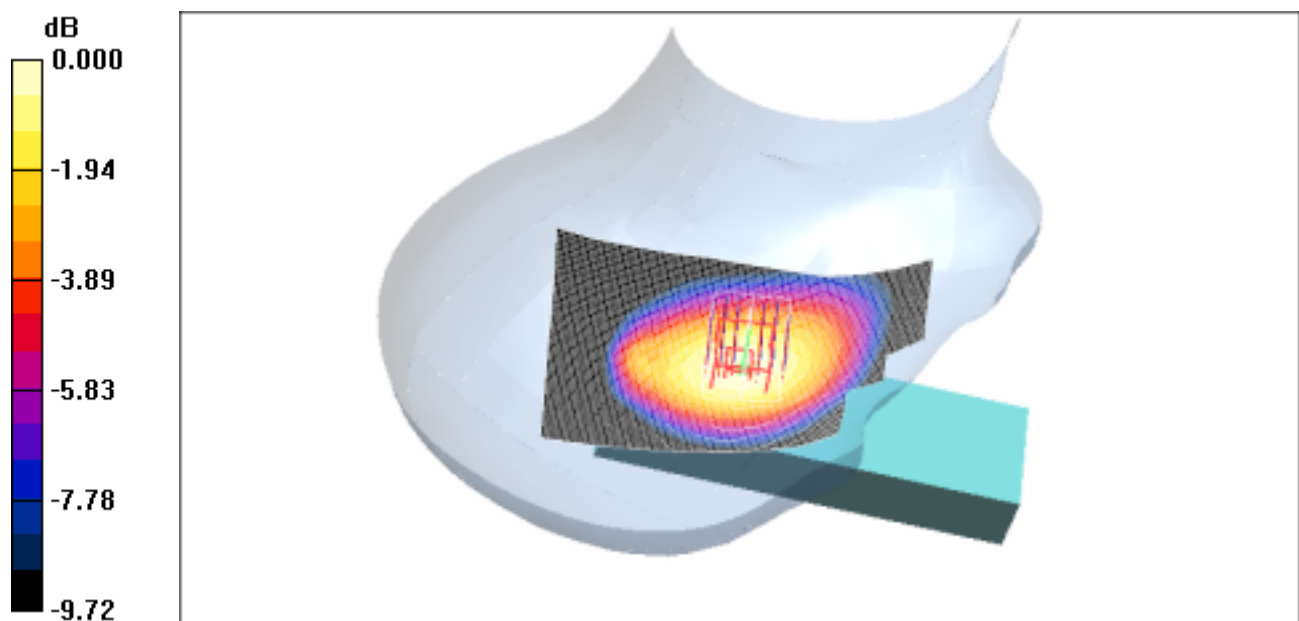

0 dB = 0.201mW/g

4.11RightHandSide-Tilt-GSM850-Middle

Date/Time: 2006-7-7 14:16:45

Test Laboratory: SGS-GSM

FCC-OET65-RightHandSide-Tilt-GSM850-Mid

DUT: GSM10006708M; Type: Head; Serial: 01090100000207-8

Communication System: GSM850-GSM Mode; Frequency: 836.4 MHz; Duty Cycle: 1:8.3

Medium: HSL850-Head Medium parameters used: $f = 836.4$ MHz; $\epsilon = 0.901$ mho/m; $\mu_r = 42.2$; $\rho = 1000$ kg/m³

Phantom section: Right Section

Measurement Standard: DASY4 (High Precision Assessment)

DASY4 Configuration:

- Probe: ES3DV3 - SN3088; ConvF(5.91, 5.91, 5.91); Calibrated: 2005-9-13
- Sensor-Surface: 4mm (Mechanical Surface Detection)
- Electronics: DAE3 Sn569; Calibrated: 2005-11-17
- Phantom: SAM 12; Type: SAM V4.0; Serial: TP-1283
- Measurement SW: DASY4, V4.6 Build 23; Postprocessing SW: SEMCAD, V1.8 Build 160

Tilt position - Middle/Area Scan (61x101x1): Measurement grid: dx=15mm, dy=15mm

Maximum value of SAR (interpolated) = 0.284 mW/g

Tilt position - Middle/Zoom Scan (7x7x7)/Cube 0: Measurement grid: dx=5mm, dy=5mm, dz=5mm

Reference Value = 13.2 V/m; Power Drift = -0.002 dB

Peak SAR (extrapolated) = 0.355 W/kg

SAR(1 g) = 0.266 mW/g; SAR(10 g) = 0.191 mW/g

Maximum value of SAR (measured) = 0.283 mW/g

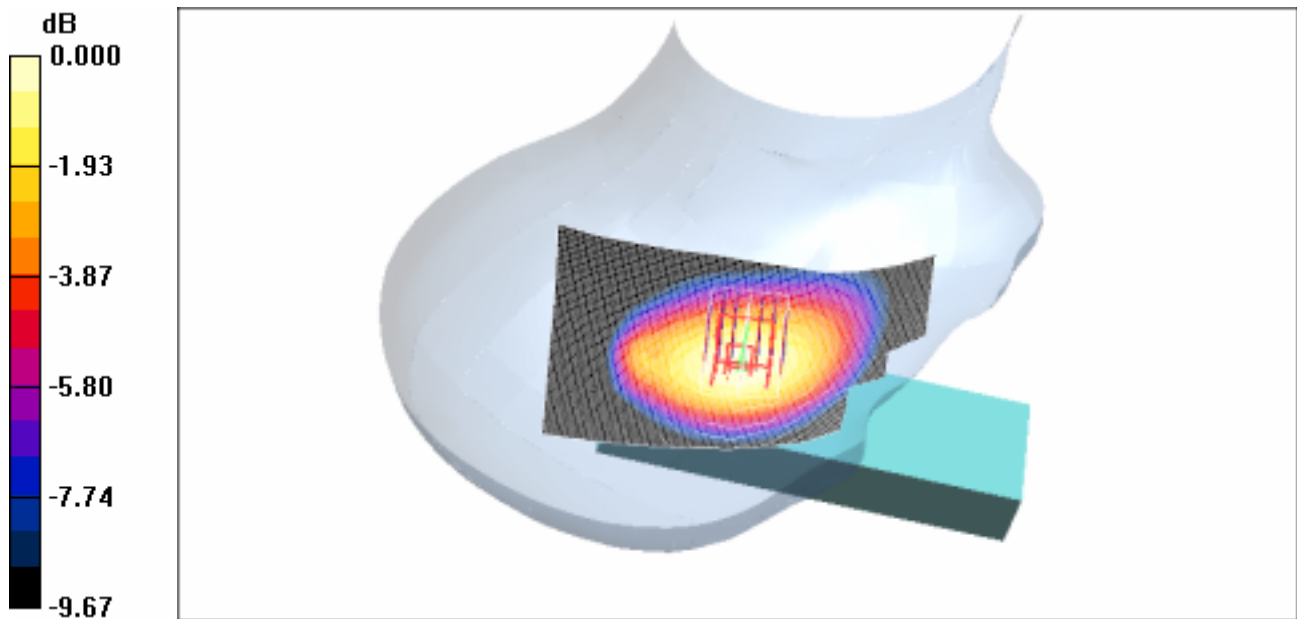

0 dB = 0.283mW/g

4.12 RightHandSide-Tilt-GSM850-High

Date/Time: 2006-7-7 14:44:18

Test Laboratory: SGS-GSM

FCC-OET65-RightHandSide-Tilt-GSM850-High

DUT: GSM10006708M; Type: Head; Serial: 01090100000207-8

Communication System: GSM850-GSM Mode; Frequency: 848.8 MHz; Duty Cycle: 1:8.3

Medium: HSL850-Head Medium parameters used: $f = 848.8$ MHz; $\sigma = 0.921$ mho/m; $\epsilon_r = 42.2$; $\rho = 1000$ kg/m³

Phantom section: Right Section

Measurement Standard: DASY4 (High Precision Assessment)

DASY4 Configuration:

- Probe: ES3DV3 - SN3088; ConvF(5.91, 5.91, 5.91); Calibrated: 2005-9-13
- Sensor-Surface: 4mm (Mechanical Surface Detection)
- Electronics: DAE3 Sn569; Calibrated: 2005-11-17

- Phantom: SAM 12; Type: SAM V4.0; Serial: TP-1283
- Measurement SW: DASY4, V4.6 Build 23; Postprocessing SW: SEMCAD, V1.8 Build 160

Tilt position - High/Area Scan (61x91x1): Measurement grid: dx=15mm, dy=15mm

Maximum value of SAR (interpolated) = 0.491 mW/g

Tilt position - High/Zoom Scan (7x7x7) (7x7x7)/Cube 0: Measurement grid: dx=5mm, dy=5mm, dz=5mm

Reference Value = 17.2 V/m; Power Drift = -0.001 dB

Peak SAR (extrapolated) = 0.617 W/kg

SAR(1 g) = 0.462 mW/g; SAR(10 g) = 0.329 mW/g

Maximum value of SAR (measured) = 0.490 mW/g

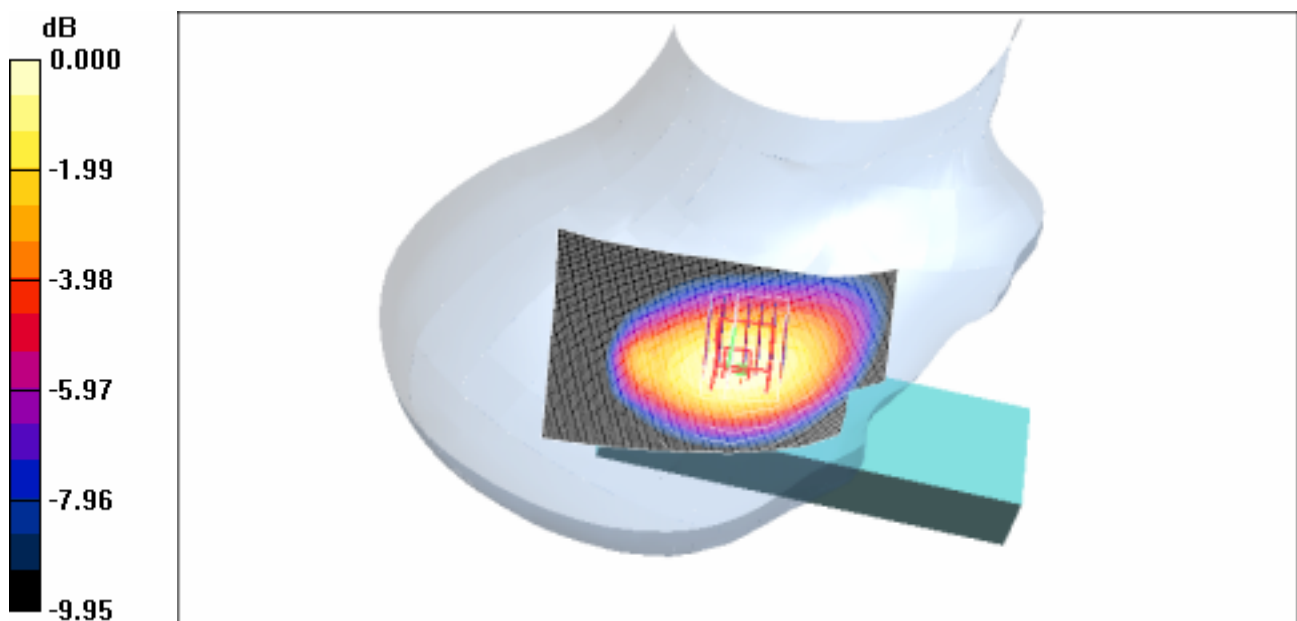

0 dB = 0.490mW/g

4.13Body-Worn-GSM850-GPRS-Low

Date/Time: 2006-7-6 13:13:46

Test Laboratory: SGS-GSM

FCC-OET65-Body-Worn-GSM850-GPRS-2cm-Low

DUT: GSM10006708M; Type: Body; Serial: 01090100000207-8

Communication System: GSM850-GPRS Mode; Frequency: 824.2 MHz; Duty Cycle: 1:4

Medium: HSL850-Body Medium parameters used: $f = 824.2$ MHz; $\sigma = 0.984$ mho/m; $r = 52.6$; $\rho = 1000$ kg/m³

Phantom section: Flat Section

Measurement Standard: DASY4 (High Precision Assessment)

DASY4 Configuration:

- Probe: ES3DV3 - SN3088; ConvF(5.83, 5.83, 5.83); Calibrated: 2005-9-13
- Sensor-Surface: 4mm (Mechanical Surface Detection)
- Electronics: DAE3 Sn569; Calibrated: 2005-11-17
- Phantom: SAM 12; Type: SAM V4.0; Serial: TP-1283
- Measurement SW: DASY4, V4.6 Build 23; Postprocessing SW: SEMCAD, V1.8 Build 160

Body Worn - Low/Area Scan (51x91x1): Measurement grid: dx=15mm, dy=15mm

Maximum value of SAR (interpolated) = 0.175 mW/g

Body Worn - Low/Zoom Scan (7x7x7) (7x7x7)/Cube 0: Measurement grid: dx=5mm, dy=5mm, dz=5mm

Reference Value = 12.5 V/m; Power Drift = 0.139 dB

Peak SAR (extrapolated) = 0.220 W/kg

SAR(1 g) = 0.165 mW/g; SAR(10 g) = 0.121 mW/g

Maximum value of SAR (measured) = 0.177 mW/g

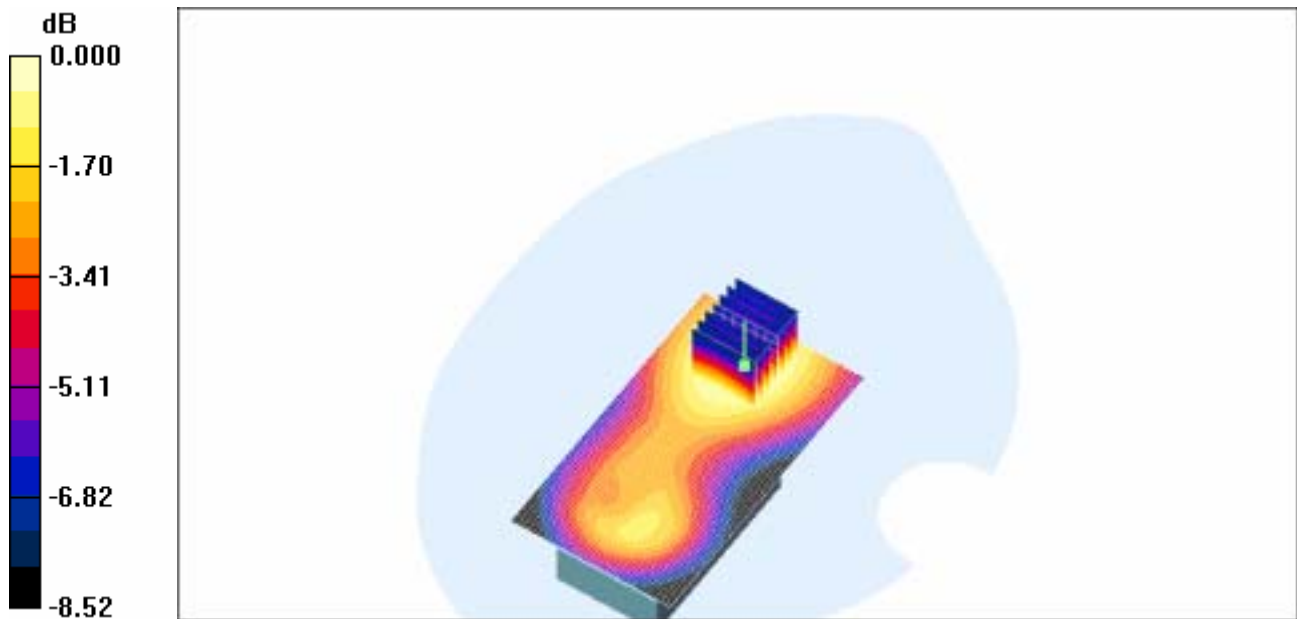

0 dB = 0.177mW/g

4.14 Body-Worn-GSM850-GPRS-Middle

Date/Time: 2006-7-6 13:35:29

Test Laboratory: SGS-GSM

FCC-OET65-Body-Worn-GSM850-GPRS-2cm-Mid

DUT: GSM10006708M; Type: Body; Serial: 01090100000207-8

Communication System: GSM850-GPRS Mode; Frequency: 836.4 MHz; Duty Cycle: 1:4

Medium: HSL850-Body Medium parameters used: $f = 836.4 \text{ MHz}$; $\sigma = 0.998 \text{ mho/m}$; $r = 52.5$; $\rho = 1000 \text{ kg/m}^3$

Phantom section: Flat Section

Measurement Standard: DASY4 (High Precision Assessment)

DASY4 Configuration:

- Probe: ES3DV3 - SN3088; ConvF(5.83, 5.83, 5.83); Calibrated: 2005-9-13
- Sensor-Surface: 4mm (Mechanical Surface Detection)
- Electronics: DAE3 Sn569; Calibrated: 2005-11-17

- Phantom: SAM 12; Type: SAM V4.0; Serial: TP-1283
- Measurement SW: DASY4, V4.6 Build 23; Postprocessing SW: SEMCAD, V1.8 Build 160

Body Worn - Middle/Area Scan (51x91x1): Measurement grid: dx=15mm, dy=15mm

Maximum value of SAR (interpolated) = 0.214 mW/g

Body Worn - Middle/Zoom Scan (7x7x7)/Cube 0: Measurement grid: dx=5mm, dy=5mm, dz=5mm

Reference Value = 13.8 V/m; Power Drift = 0.019 dB

Peak SAR (extrapolated) = 0.269 W/kg

SAR(1 g) = 0.204 mW/g; SAR(10 g) = 0.149 mW/g

Maximum value of SAR (measured) = 0.214 mW/g

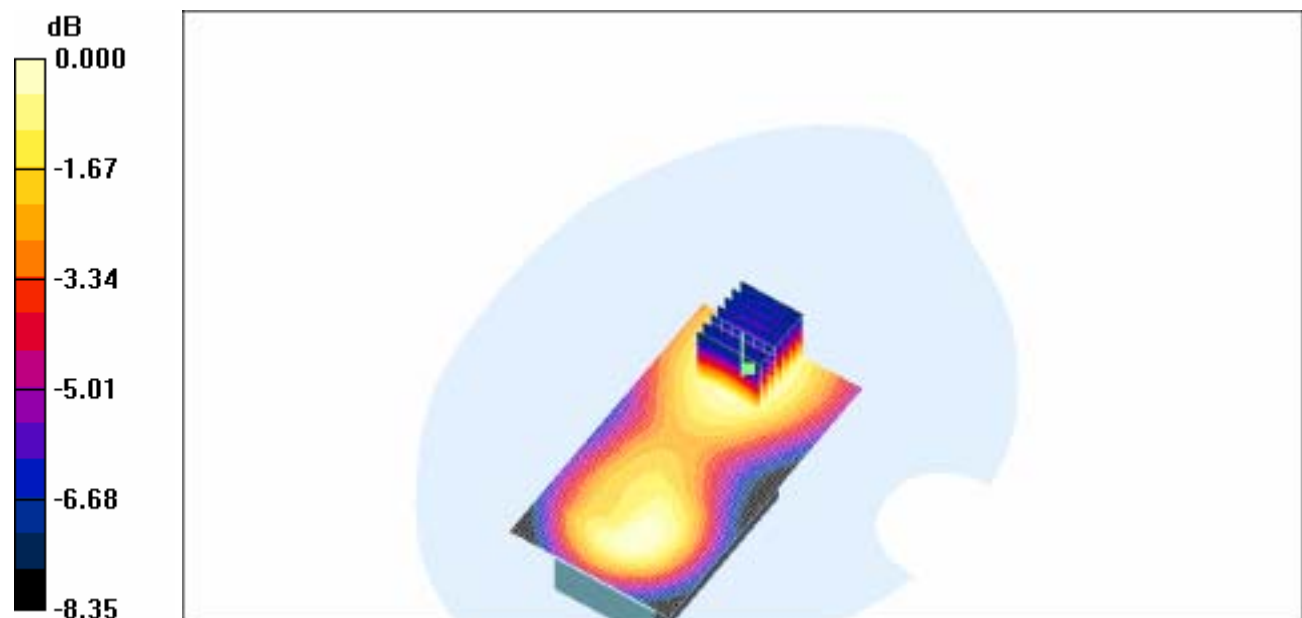

0 dB = 0.214mW/g

4.15 Body-Worn-GSM850-GPRS-High

Date/Time: 2006-7-6 13:57:15

Test Laboratory: SGS-GSM

FCC-OET65-Body-Worn-GSM850-GPRS-2cm-High

DUT: GSM10006708M; Type: Body; Serial: 01090100000207-8

Communication System: GSM850-GPRS Mode; Frequency: 848.8 MHz; Duty Cycle: 1:4

Medium: HSL850-Body Medium parameters used: $f = 848.8$ MHz; $\sigma = 1.01$ mho/m; $r = 52.5$; $\rho = 1000$ kg/m³

Phantom section: Flat Section

Measurement Standard: DAS4 (High Precision Assessment)

DASY4 Configuration:

- Probe: ES3DV3 - SN3088; ConvF(5.83, 5.83, 5.83); Calibrated: 2005-9-13
- Sensor-Surface: 4mm (Mechanical Surface Detection)
- Electronics: DAE3 Sn569; Calibrated: 2005-11-17
- Phantom: SAM 12; Type: SAM V4.0; Serial: TP-1283
- Measurement SW: DAS4, V4.6 Build 23; Postprocessing SW: SEMCAD, V1.8 Build 160

Body Worn - High/Area Scan (51x91x1): Measurement grid: dx=15mm, dy=15mm

Maximum value of SAR (interpolated) = 0.404 mW/g

Body Worn - High/Zoom Scan (7x7x7) (7x7x7)/Cube 0: Measurement grid: dx=5mm, dy=5mm, dz=5mm

Reference Value = 16.3 V/m; Power Drift = 0.016 dB

Peak SAR (extrapolated) = 0.585 W/kg

SAR(1 g) = 0.372 mW/g; SAR(10 g) = 0.236 mW/g

Maximum value of SAR (measured) = 0.404 mW/g

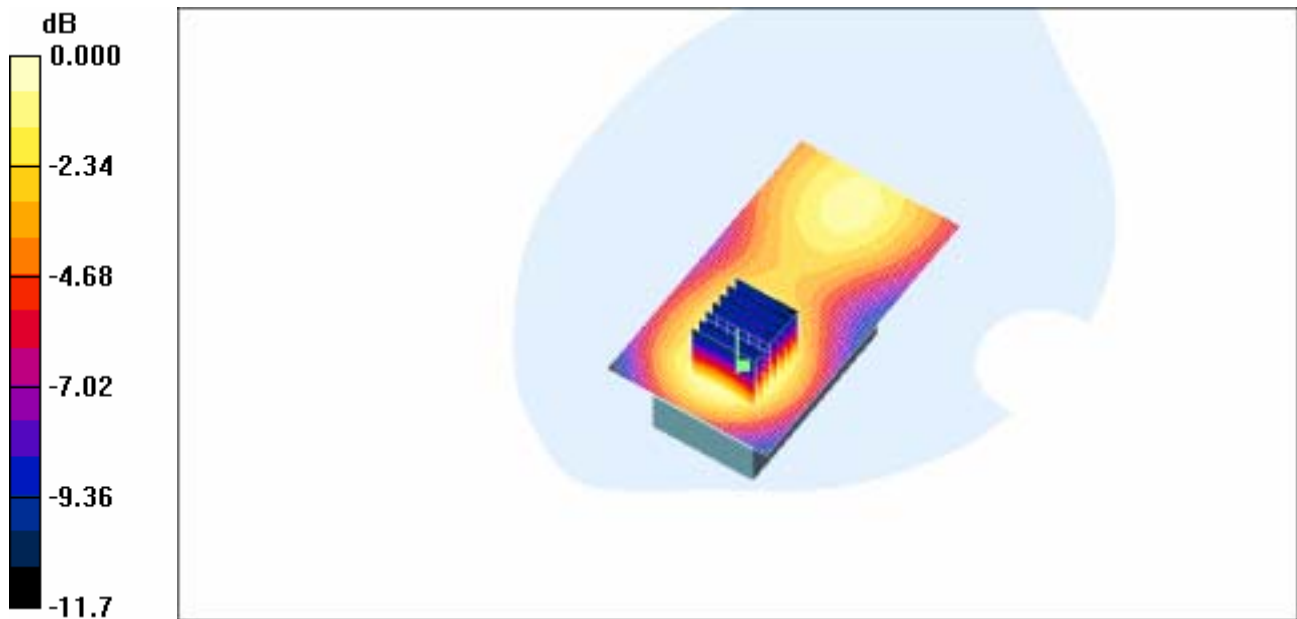

0 dB = 0.404mW/g

4.16 LeftHandSide-Cheek-PCS1900-Low

Date/Time: 2006-7-12 8:43:59

Test Laboratory: SGS-GSM

FCC-OET65-LeftHandSide-Cheek-PCS1900-Low

DUT: GSM10006708M; Type: Head; Serial: 01090100000207-8

Communication System: PCS1900-GSM Mode; Frequency: 1850.2 MHz; Duty Cycle: 1:8.3

Medium: HSL1900 Medium parameters used: $f = 1850.2 \text{ MHz}$; $\sigma = 1.42 \text{ mho/m}$; $r = 40.5$; $\rho = 1000 \text{ kg/m}^3$

Phantom section: Left Section

Measurement Standard: DASY4 (High Precision Assessment)

DASY4 Configuration:

- Probe: ES3DV3 - SN3088; ConvF(4.93, 4.93, 4.93); Calibrated: 2005-9-13
- Sensor-Surface: 4mm (Mechanical Surface Detection)
- Electronics: DAE3 Sn569; Calibrated: 2005-11-17

- Phantom: SAM 12; Type: SAM V4.0; Serial: TP-1283
- Measurement SW: DASY4, V4.6 Build 23; Postprocessing SW: SEMCAD, V1.8 Build 160

Cheek position - Low/Area Scan (71x111x1): Measurement grid: dx=15mm, dy=15mm

Maximum value of SAR (interpolated) = 0.323 mW/g

Cheek position - Low/Zoom Scan (7x7x7) (7x7x7)/Cube 0: Measurement grid: dx=5mm, dy=5mm, dz=5mm

Reference Value = 2.92 V/m; Power Drift = -0.342 dB

Peak SAR (extrapolated) = 0.418 W/kg

SAR(1 g) = 0.283 mW/g; SAR(10 g) = 0.171 mW/g

Maximum value of SAR (measured) = 0.305 mW/g

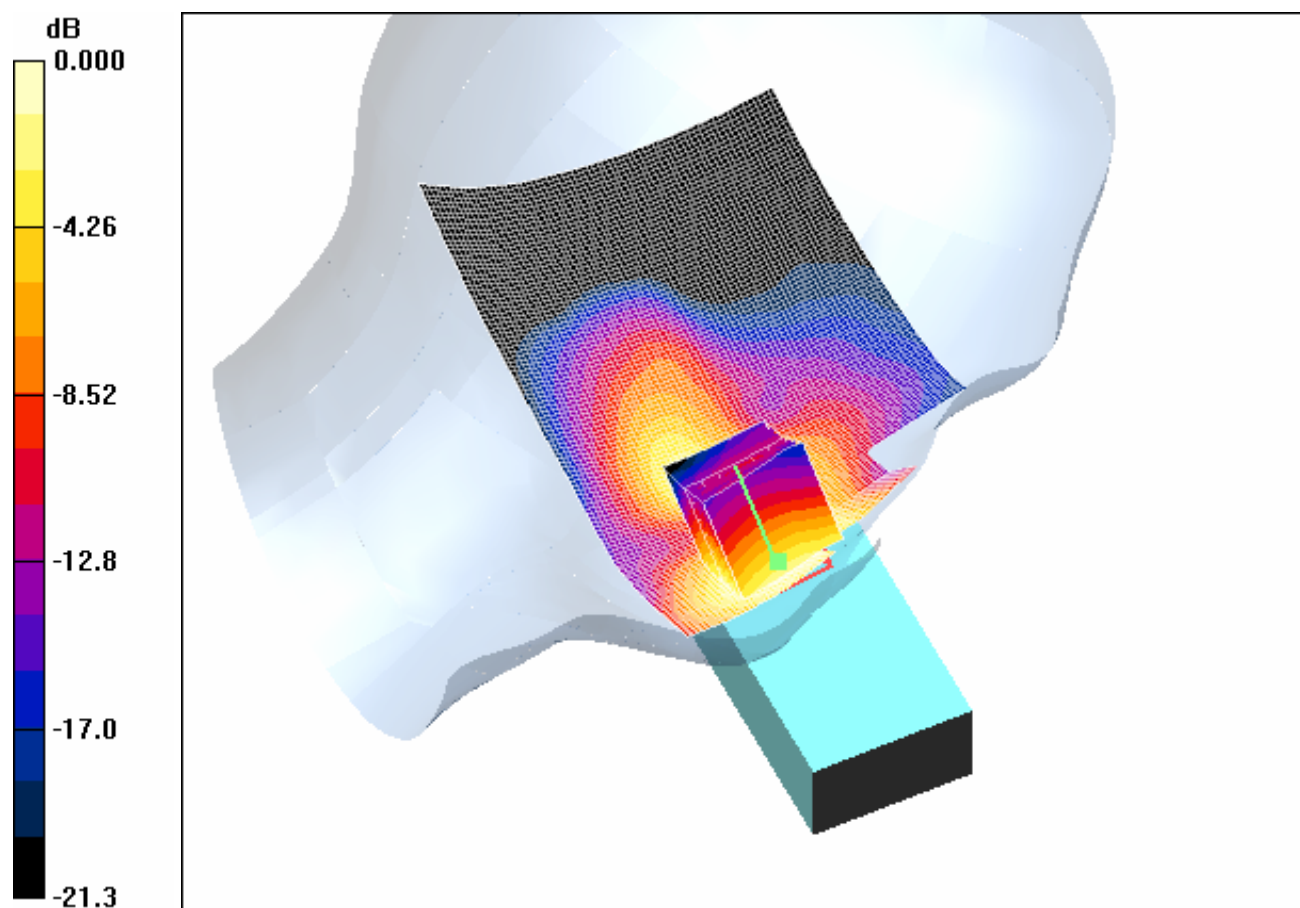

0 dB = 0.305mW/g

4.17LeftHandSide-Cheek-PCS1900-Middle

Date/Time: 2006-7-11 16:41:08

Test Laboratory: SGS-GSM

FCC-OET65-LeftHandSide-Cheek-PCS1900-Mid

DUT: GSM10006708M; Type: Head; Serial: 01090100000207-8

Communication System: PCS1900-GSM Mode; Frequency: 1880 MHz; Duty Cycle: 1:8.3

Medium: HSL1900 Medium parameters used: $f = 1880 \text{ MHz}$; $\sigma = 1.44 \text{ mho/m}$; $\rho = 40.3$; $\rho = 1000 \text{ kg/m}^3$

Phantom section: Left Section

Measurement Standard: DAS4 (High Precision Assessment)

DASY4 Configuration:

- Probe: ES3DV3 - SN3088; ConvF(4.93, 4.93, 4.93); Calibrated: 2005-9-13
- Sensor-Surface: 4mm (Mechanical Surface Detection)
- Electronics: DAE3 Sn569; Calibrated: 2005-11-17
- Phantom: SAM 12; Type: SAM V4.0; Serial: TP-1283
- Measurement SW: DAS4, V4.6 Build 23; Postprocessing SW: SEMCAD, V1.8 Build 160

Cheek position - Middle/Area Scan (71x111x1): Measurement grid: dx=15mm, dy=15mm

Maximum value of SAR (interpolated) = 0.327 mW/g

Cheek position - Middle/Zoom Scan (7x7x7)/Cube 0: Measurement grid: dx=5mm, dy=5mm, dz=5mm

Reference Value = 3.28 V/m; Power Drift = 0.175 dB

Peak SAR (extrapolated) = 0.429 W/kg

SAR(1 g) = 0.287 mW/g; SAR(10 g) = 0.172 mW/g

Maximum value of SAR (measured) = 0.311 mW/g

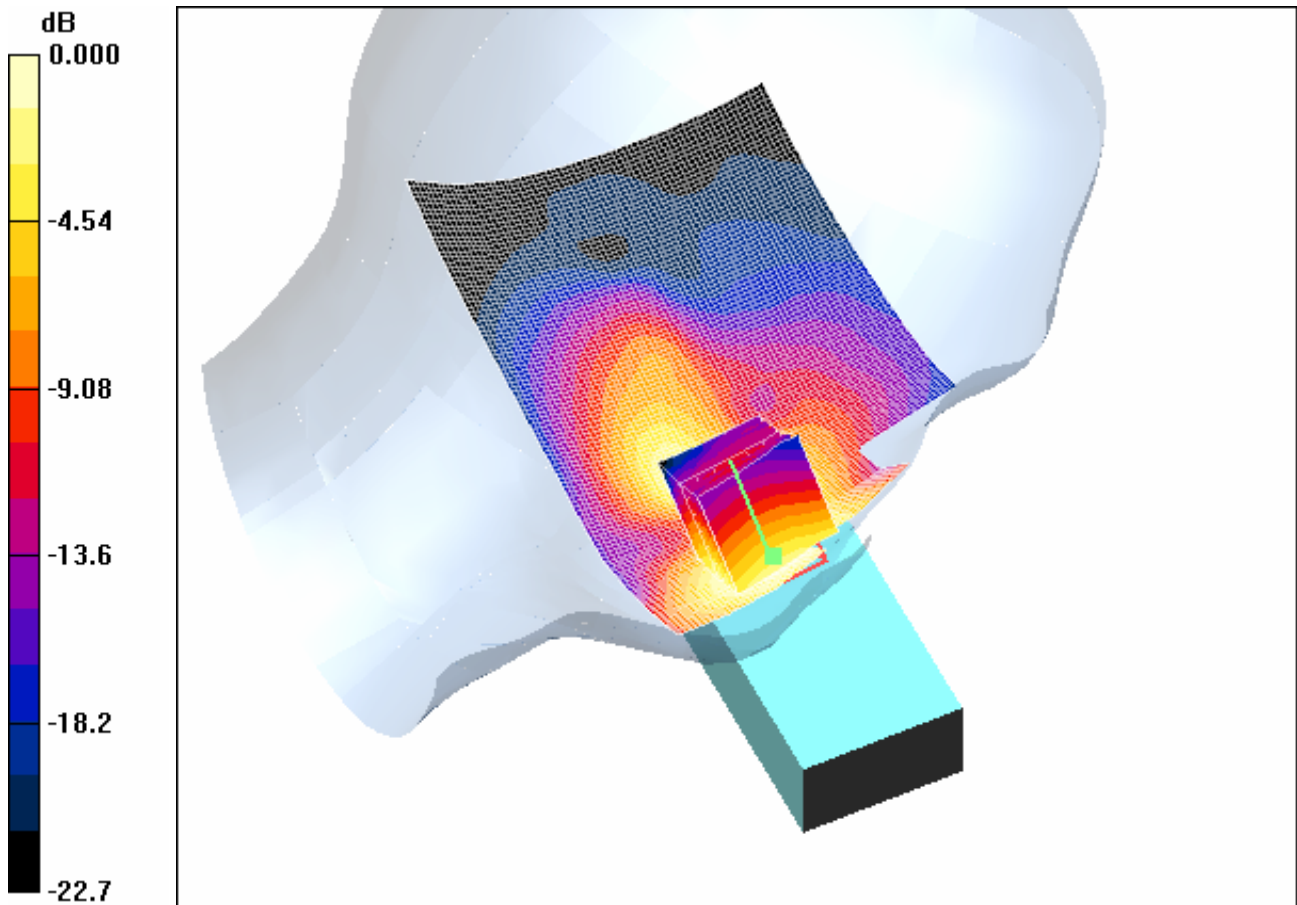

0 dB = 0.311mW/g

4.18LeftHandSide-Cheek-PCS1900-High

Date/Time: 2006-7-12 9:22:56

Test Laboratory: SGS-GSM

FCC-OET65-LeftHandSide-Cheek-PCS1900-High

DUT: GSM10006708M; Type: Head; Serial: 01090100000207-8

Communication System: PCS1900-GSM Mode; Frequency: 1909.8 MHz;Duty Cycle: 1:8.3

Medium: HSL1900 Medium parameters used: $f = 1909.8 \text{ MHz}$; $\sigma = 1.47 \text{ mho/m}$; $\epsilon_r = 40$; $\rho = 1000 \text{ kg/m}^3$

Phantom section: Left Section

Measurement Standard: DASY4 (High Precision Assessment)

DASY4 Configuration:

- Probe: ES3DV3 - SN3088; ConvF(4.93, 4.93, 4.93); Calibrated: 2005-9-13
- Sensor-Surface: 4mm (Mechanical Surface Detection)
- Electronics: DAE3 Sn569; Calibrated: 2005-11-17
- Phantom: SAM 12; Type: SAM V4.0; Serial: TP-1283
- Measurement SW: DASY4, V4.6 Build 23; Postprocessing SW: SEMCAD, V1.8 Build 160

Cheek position - High/Area Scan (71x111x1): Measurement grid: dx=15mm, dy=15mm

Maximum value of SAR (interpolated) = 0.348 mW/g

Cheek position - High/Zoom Scan (7x7x7) (7x7x7)/Cube 0: Measurement grid: dx=5mm, dy=5mm, dz=5mm

Reference Value = 3.45 V/m; Power Drift = -0.071 dB

Peak SAR (extrapolated) = 0.452 W/kg

SAR(1 g) = 0.301 mW/g; SAR(10 g) = 0.179 mW/g

Maximum value of SAR (measured) = 0.328 mW/g

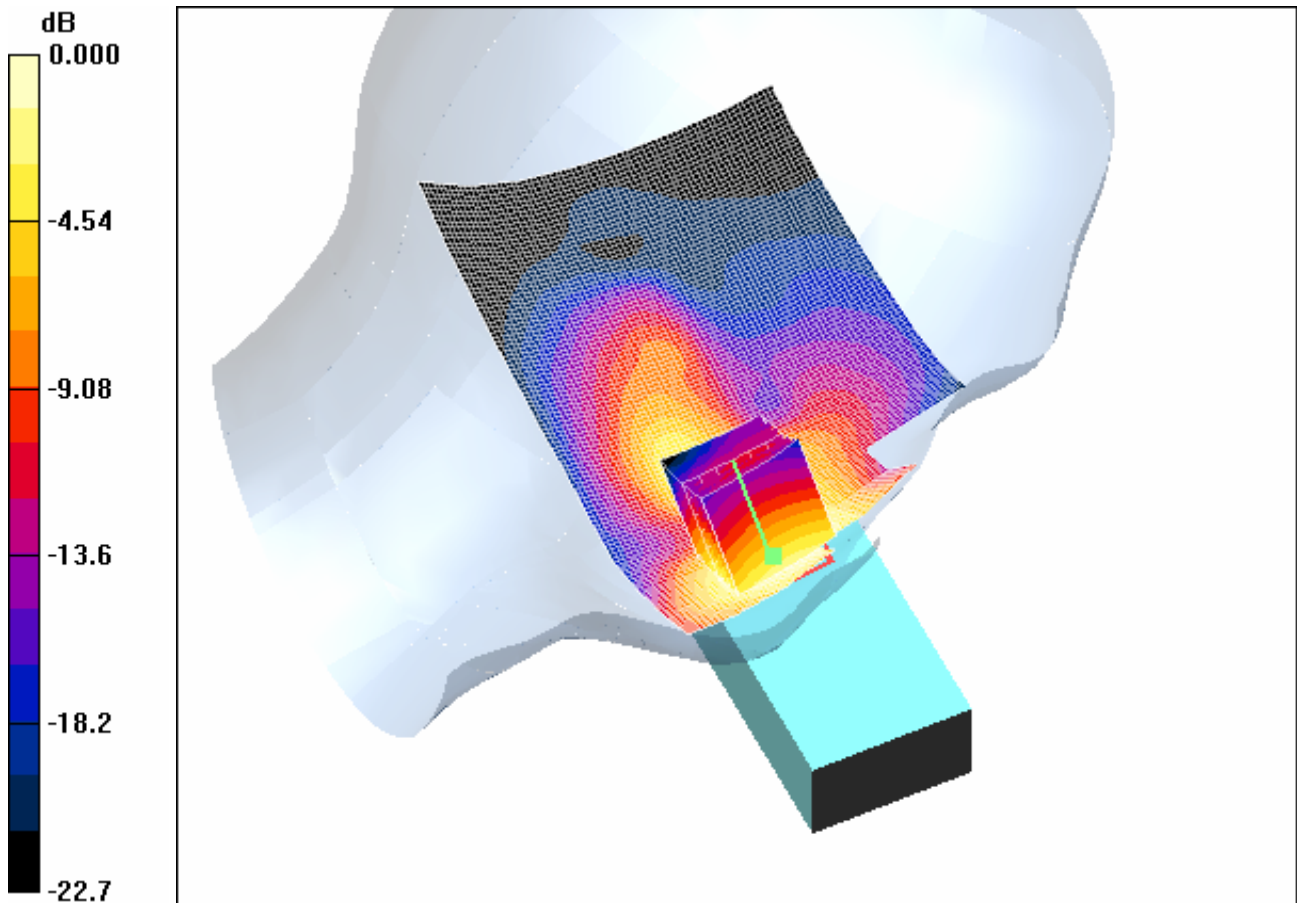

0 dB = 0.328mW/g

4.19LeftHandSide-Tilt-PCS1900-Low

Date/Time: 2006-7-12 10:21:37

Test Laboratory: SGS-GSM

FCC-OET65-LeftHandSide-Tilt-PCS1900-Low

DUT: GSM10006708M; Type: Head; Serial: 01090100000207-8

Communication System: PCS1900-GSM Mode; Frequency: 1850.2 MHz;Duty Cycle: 1:8.3

Medium: HSL1900 Medium parameters used: $f = 1850.2 \text{ MHz}$; $\sigma = 1.42 \text{ mho/m}$; $\epsilon_r = 40.5$; $\rho = 1000 \text{ kg/m}^3$

Phantom section: Left Section

Measurement Standard: DASY4 (High Precision Assessment)

DASY4 Configuration:

- Probe: ES3DV3 - SN3088; ConvF(4.93, 4.93, 4.93); Calibrated: 2005-9-13
- Sensor-Surface: 4mm (Mechanical Surface Detection)
- Electronics: DAE3 Sn569; Calibrated: 2005-11-17
- Phantom: SAM 12; Type: SAM V4.0; Serial: TP-1283
- Measurement SW: DASY4, V4.6 Build 23; Postprocessing SW: SEMCAD, V1.8 Build 160

Tilt position - Low/Area Scan (71x111x1): Measurement grid: dx=15mm, dy=15mm

Maximum value of SAR (interpolated) = 0.061 mW/g

Tilt position - Low/Zoom Scan (7x7x7) (7x7x7)/Cube 0: Measurement grid: dx=5mm, dy=5mm, dz=5mm

Reference Value = 5.71 V/m; Power Drift = -0.050 dB

Peak SAR (extrapolated) = 0.081 W/kg

SAR(1 g) = 0.052 mW/g; SAR(10 g) = 0.031 mW/g

Maximum value of SAR (measured) = 0.058 mW/g

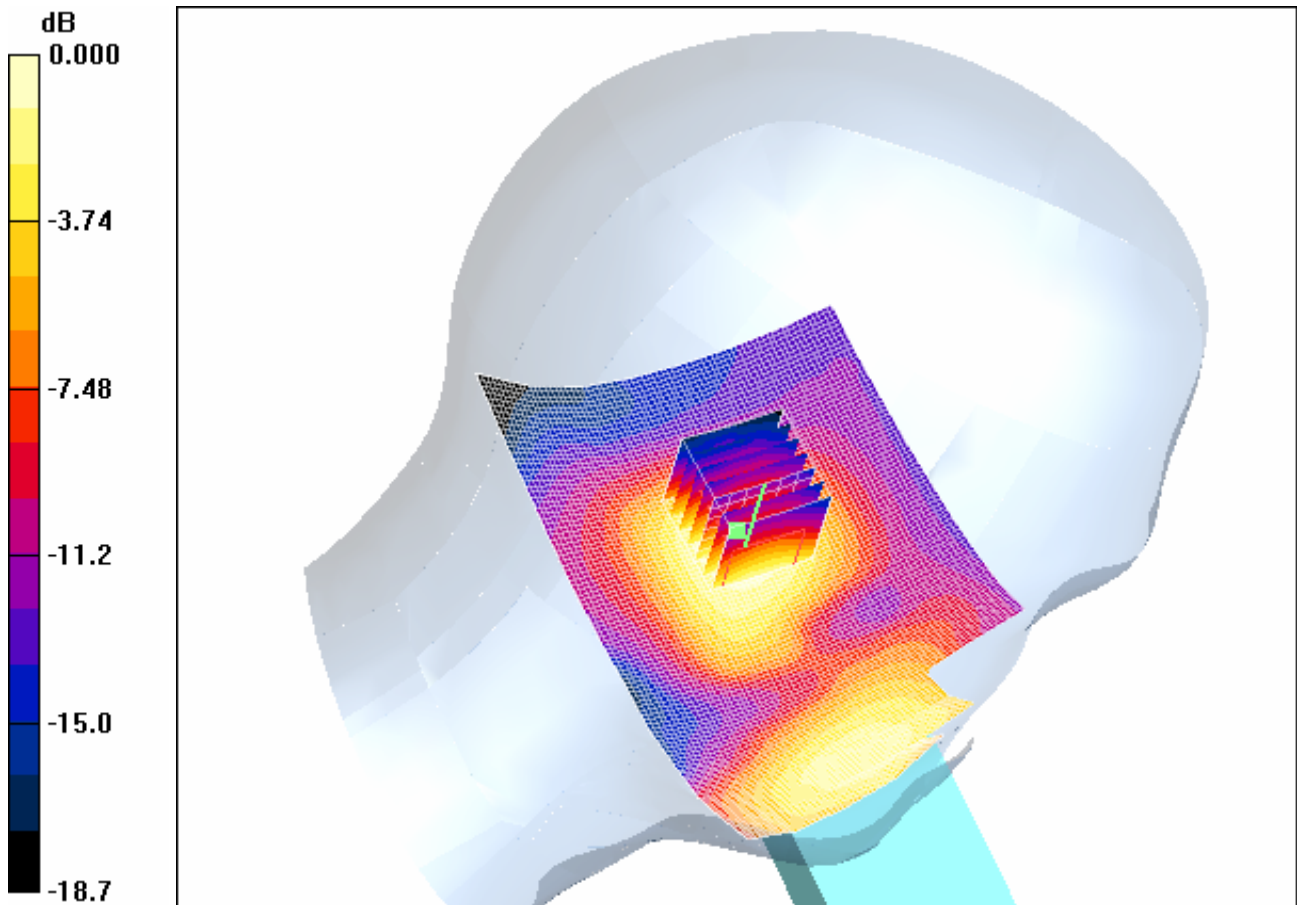

0 dB = 0.058mW/g

4.20LeftHandSide-Tilt-PCS1900-Middle

Date/Time: 2006-7-12 10:56:54

Test Laboratory: SGS-GSM

FCC-OET65-LeftHandSide-Tilt-PCS1900-Mid

DUT: GSM10006708M; Type: Head; Serial: 01090100000207-8

Communication System: PCS1900-GSM Mode; Frequency: 1880 MHz;Duty Cycle: 1:8.3

Medium: HSL1900 Medium parameters used: $f = 1880$ MHz; $\sigma = 1.44$ mho/m; $\epsilon_r = 40.3$; $\rho = 1000$ kg/m³

Phantom section: Left Section

Measurement Standard: DASY4 (High Precision Assessment)

DASY4 Configuration:

- Probe: ES3DV3 - SN3088; ConvF(4.93, 4.93, 4.93); Calibrated: 2005-9-13
- Sensor-Surface: 4mm (Mechanical Surface Detection)
- Electronics: DAE3 Sn569; Calibrated: 2005-11-17
- Phantom: SAM 12; Type: SAM V4.0; Serial: TP-1283
- Measurement SW: DASY4, V4.6 Build 23; Postprocessing SW: SEMCAD, V1.8 Build 160

Tilt position - Middle/Area Scan (71x111x1): Measurement grid: dx=15mm, dy=15mm

Maximum value of SAR (interpolated) = 0.060 mW/g

Tilt position - Middle/Zoom Scan (7x7x7)/Cube 0: Measurement grid: dx=5mm, dy=5mm, dz=5mm

Reference Value = 5.68 V/m; Power Drift = -0.070 dB

Peak SAR (extrapolated) = 0.081 W/kg

SAR(1 g) = 0.052 mW/g; SAR(10 g) = 0.029 mW/g

Maximum value of SAR (measured) = 0.056 mW/g

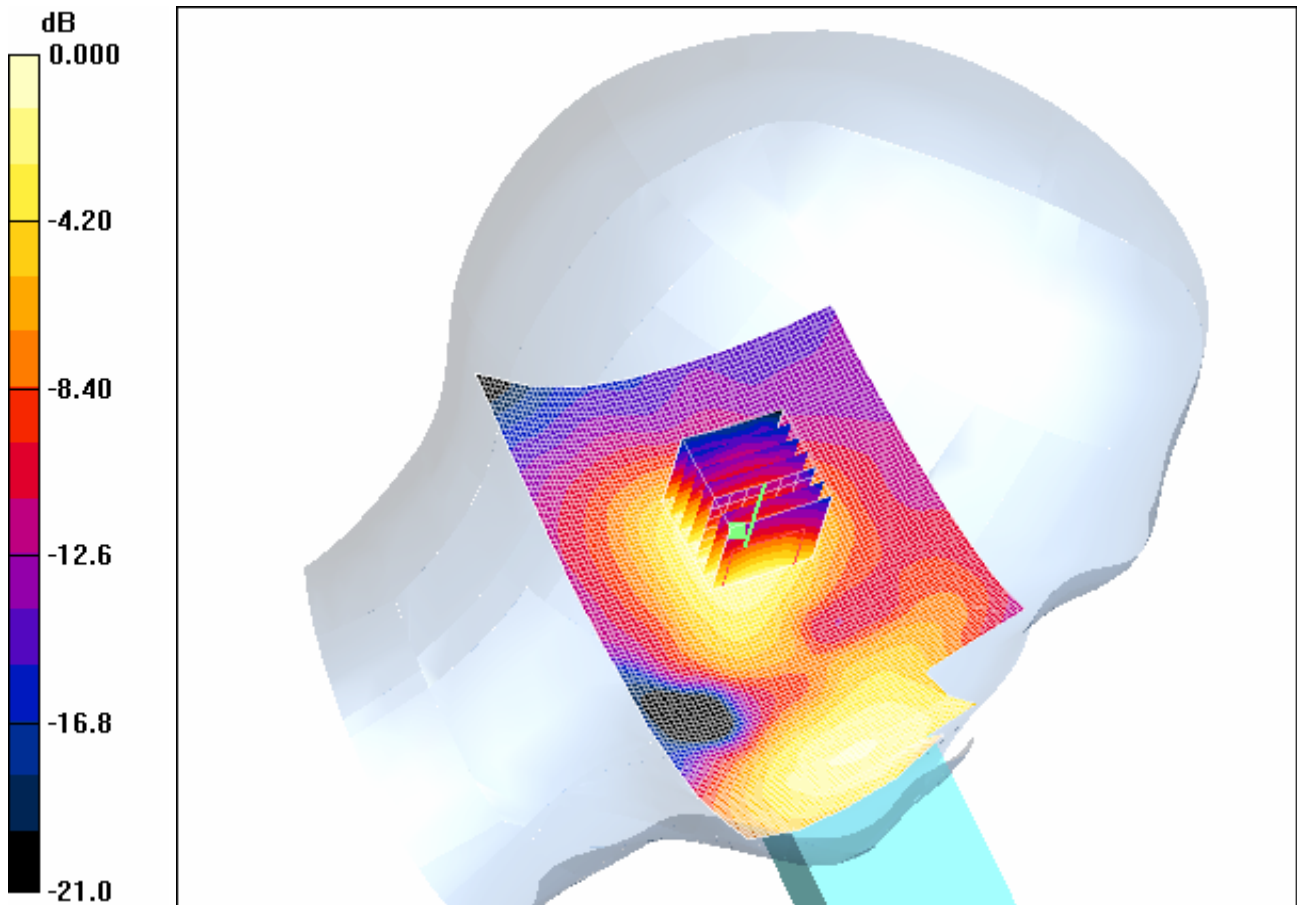

0 dB = 0.056mW/g

4.21LeftHandSide-Tilt-PCS1900-High

Date/Time: 2006-7-12 11:30:23

Test Laboratory: SGS-GSM

FCC-OET65-LeftHandSide-Tilt-PCS1900-High

DUT: GSM10006708M; Type: Head; Serial: 01090100000207-8

Communication System: PCS1900-GSM Mode; Frequency: 1909.8 MHz;Duty Cycle: 1:8.3

Medium: HSL1900 Medium parameters used: $f = 1909.8 \text{ MHz}$; $\sigma = 1.47 \text{ mho/m}$; $\epsilon_r = 40$; $\rho = 1000 \text{ kg/m}^3$

Phantom section: Left Section

Measurement Standard: DASY4 (High Precision Assessment)

DASY4 Configuration:

- Probe: ES3DV3 - SN3088; ConvF(4.93, 4.93, 4.93); Calibrated: 2005-9-13
- Sensor-Surface: 4mm (Mechanical Surface Detection)
- Electronics: DAE3 Sn569; Calibrated: 2005-11-17
- Phantom: SAM 12; Type: SAM V4.0; Serial: TP-1283
- Measurement SW: DASY4, V4.6 Build 23; Postprocessing SW: SEMCAD, V1.8 Build 160

Tilt position - High/Area Scan (71x111x1): Measurement grid: dx=15mm, dy=15mm

Maximum value of SAR (interpolated) = 0.052 mW/g

Tilt position - High/Zoom Scan (7x7x7) (7x7x7)/Cube 0: Measurement grid: dx=5mm, dy=5mm, dz=5mm

Reference Value = 5.36 V/m; Power Drift = 0.005 dB

Peak SAR (extrapolated) = 0.073 W/kg

SAR(1 g) = 0.046 mW/g; SAR(10 g) = 0.025 mW/g

Maximum value of SAR (measured) = 0.051 mW/g

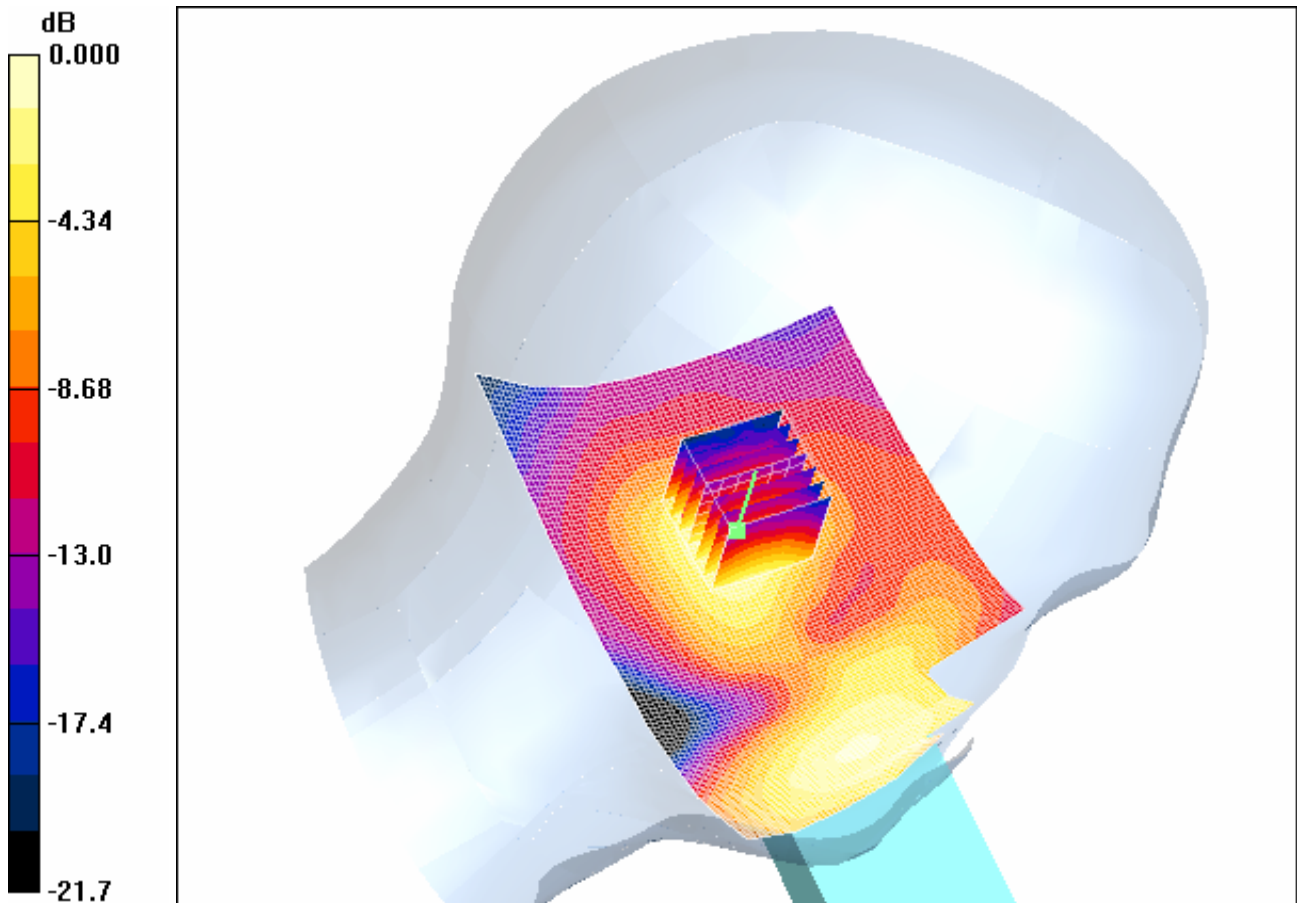

0 dB = 0.051mW/g

4.22RightHandSide-Cheek-PCS1900-Low

Date/Time: 2006-7-11 10:35:41

Test Laboratory: SGS-GSM

FCC-OET65-RightHandSide-Cheek-PCS1900-Low

DUT: GSM10006708M; Type: Head; Serial: 01090100000207-8

Communication System: PCS1900-GSM Mode; Frequency: 1850.2 MHz; Duty Cycle: 1:8.3

Medium: HSL1900 Medium parameters used: $f = 1850.2 \text{ MHz}$; $\sigma = 1.42 \text{ mho/m}$; $\epsilon_r = 40.5$; $\rho = 1000 \text{ kg/m}^3$

Phantom section: Right Section

Measurement Standard: DASY4 (High Precision Assessment)

DASY4 Configuration:

- Probe: ES3DV3 - SN3088; ConvF(4.93, 4.93, 4.93); Calibrated: 2005-9-13
- Sensor-Surface: 4mm (Mechanical Surface Detection)
- Electronics: DAE3 Sn569; Calibrated: 2005-11-17
- Phantom: SAM 12; Type: SAM V4.0; Serial: TP-1283
- Measurement SW: DASY4, V4.6 Build 23; Postprocessing SW: SEMCAD, V1.8 Build 160

Cheek position - Low/Area Scan (71x111x1): Measurement grid: dx=15mm, dy=15mm

Maximum value of SAR (interpolated) = 0.355 mW/g

Cheek position - Low/Zoom Scan (7x7x7) (7x7x7)/Cube 0: Measurement grid: dx=5mm, dy=5mm, dz=5mm

Reference Value = 4.32 V/m; Power Drift = -0.239 dB

Peak SAR (extrapolated) = 0.479 W/kg

SAR(1 g) = 0.322 mW/g; SAR(10 g) = 0.192 mW/g

Maximum value of SAR (measured) = 0.348 mW/g

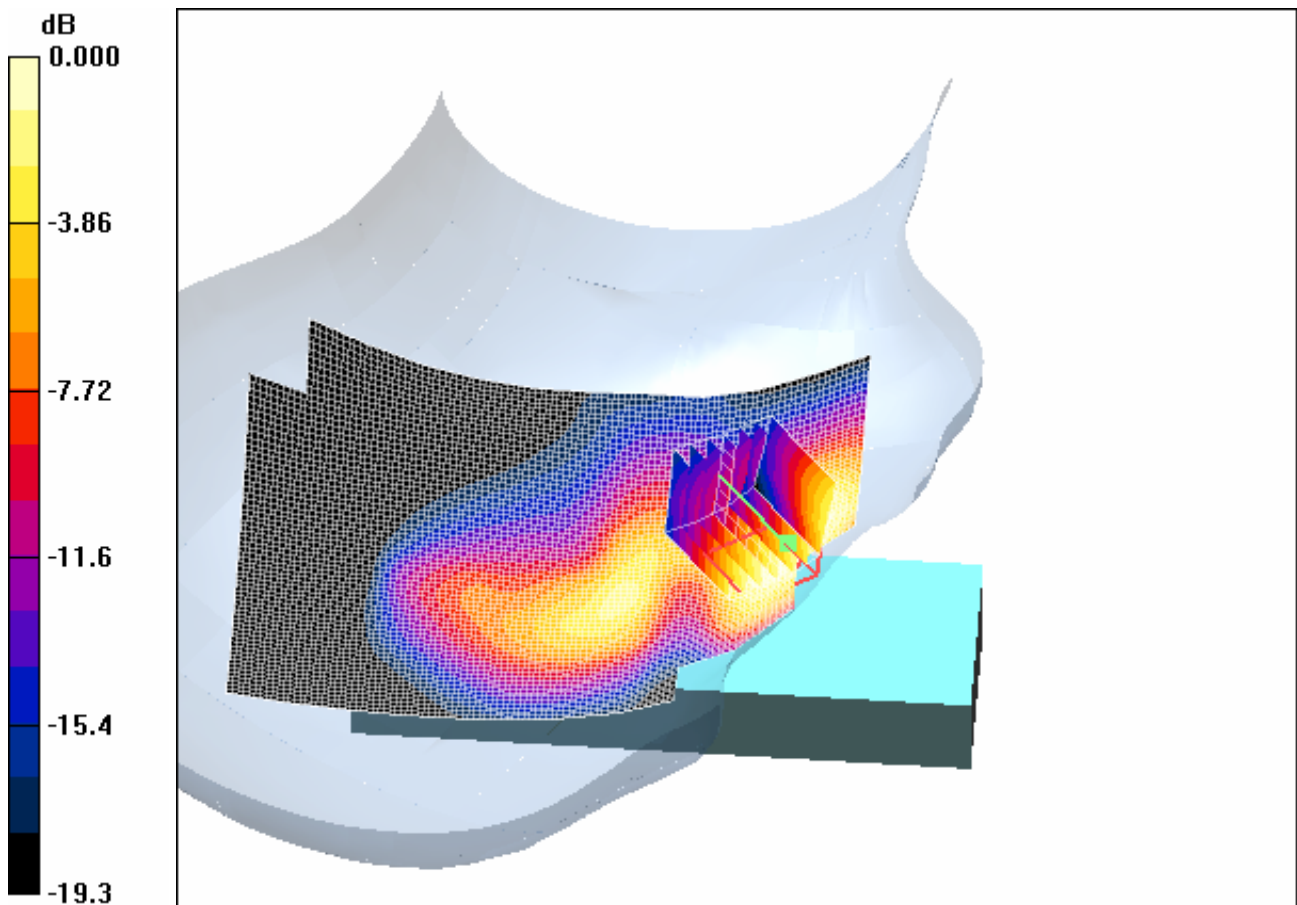

0 dB = 0.348mW/g

4.23RightHandSide-Cheek-PCS1900-Middle

Date/Time: 2006-7-11 11:14:41

Test Laboratory: SGS-GSM

FCC-OET65-RightHandSide-Cheek-PCS1900-Mid

DUT: GSM10006708M; Type: Head; Serial: 01090100000207-8

Communication System: PCS1900-GSM Mode; Frequency: 1880 MHz;Duty Cycle: 1:8.3

Medium: HSL1900 Medium parameters used: $f = 1880$ MHz; $\sigma = 1.44$ mho/m; $\epsilon_r = 40.3$; $\rho = 1000$ kg/m³

Phantom section: Right Section

Measurement Standard: DASY4 (High Precision Assessment)

DASY4 Configuration:

- Probe: ES3DV3 - SN3088; ConvF(4.93, 4.93, 4.93); Calibrated: 2005-9-13
- Sensor-Surface: 4mm (Mechanical Surface Detection)
- Electronics: DAE3 Sn569; Calibrated: 2005-11-17
- Phantom: SAM 12; Type: SAM V4.0; Serial: TP-1283
- Measurement SW: DASY4, V4.6 Build 23; Postprocessing SW: SEMCAD, V1.8 Build 160

Cheek position - Middle/Area Scan (71x111x1): Measurement grid: dx=15mm, dy=15mm

Maximum value of SAR (interpolated) = 0.379 mW/g

Cheek position - Middle/Zoom Scan (7x7x7)/Cube 0: Measurement grid: dx=5mm, dy=5mm,
dz=5mm

Reference Value = 4.54 V/m; Power Drift = -0.140 dB

Peak SAR (extrapolated) = 0.516 W/kg

SAR(1 g) = 0.341 mW/g; SAR(10 g) = 0.201 mW/g

Maximum value of SAR (measured) = 0.374 mW/g

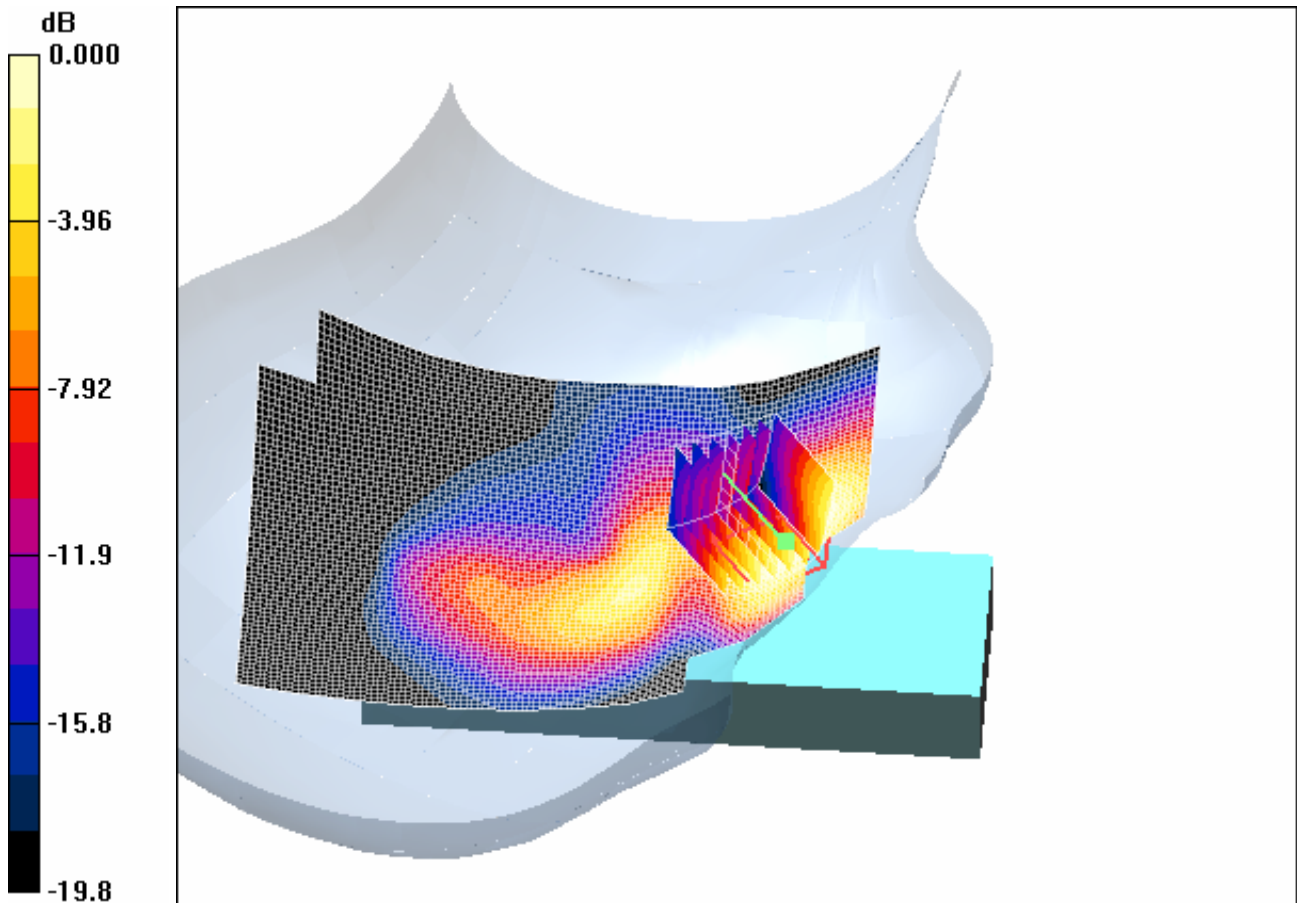

0 dB = 0.374mW/g

4.24RightHandSide-Cheek-PCS1900-High

Date/Time: 2006-7-11 12:37:01

Test Laboratory: SGS-GSM

FCC-OET65-RightHandSide-Cheek-PCS1900-High

DUT: GSM10006708M; Type: Head; Serial: 01090100000207-8

Communication System: PCS1900-GSM Mode; Frequency: 1909.8 MHz;Duty Cycle: 1:8.3

Medium: HSL1900 Medium parameters used: $f = 1909.8 \text{ MHz}$; $\sigma = 1.47 \text{ mho/m}$; $\epsilon_r = 40$; $\rho = 1000 \text{ kg/m}^3$

Phantom section: Right Section

Measurement Standard: DASY4 (High Precision Assessment)

DASY4 Configuration:

- Probe: ES3DV3 - SN3088; ConvF(4.93, 4.93, 4.93); Calibrated: 2005-9-13
- Sensor-Surface: 4mm (Mechanical Surface Detection)
- Electronics: DAE3 Sn569; Calibrated: 2005-11-17
- Phantom: SAM 12; Type: SAM V4.0; Serial: TP-1283
- Measurement SW: DASY4, V4.6 Build 23; Postprocessing SW: SEMCAD, V1.8 Build 160

Cheek position - High/Area Scan (71x111x1): Measurement grid: dx=15mm, dy=15mm

Maximum value of SAR (interpolated) = 0.391 mW/g

Cheek position - High/Zoom Scan (7x7x7) (7x7x7)/Cube 0: Measurement grid: dx=5mm, dy=5mm, dz=5mm

Reference Value = 4.67 V/m; Power Drift = -0.058 dB

Peak SAR (extrapolated) = 0.534 W/kg

SAR(1 g) = 0.346 mW/g; SAR(10 g) = 0.204 mW/g

Maximum value of SAR (measured) = 0.379 mW/g

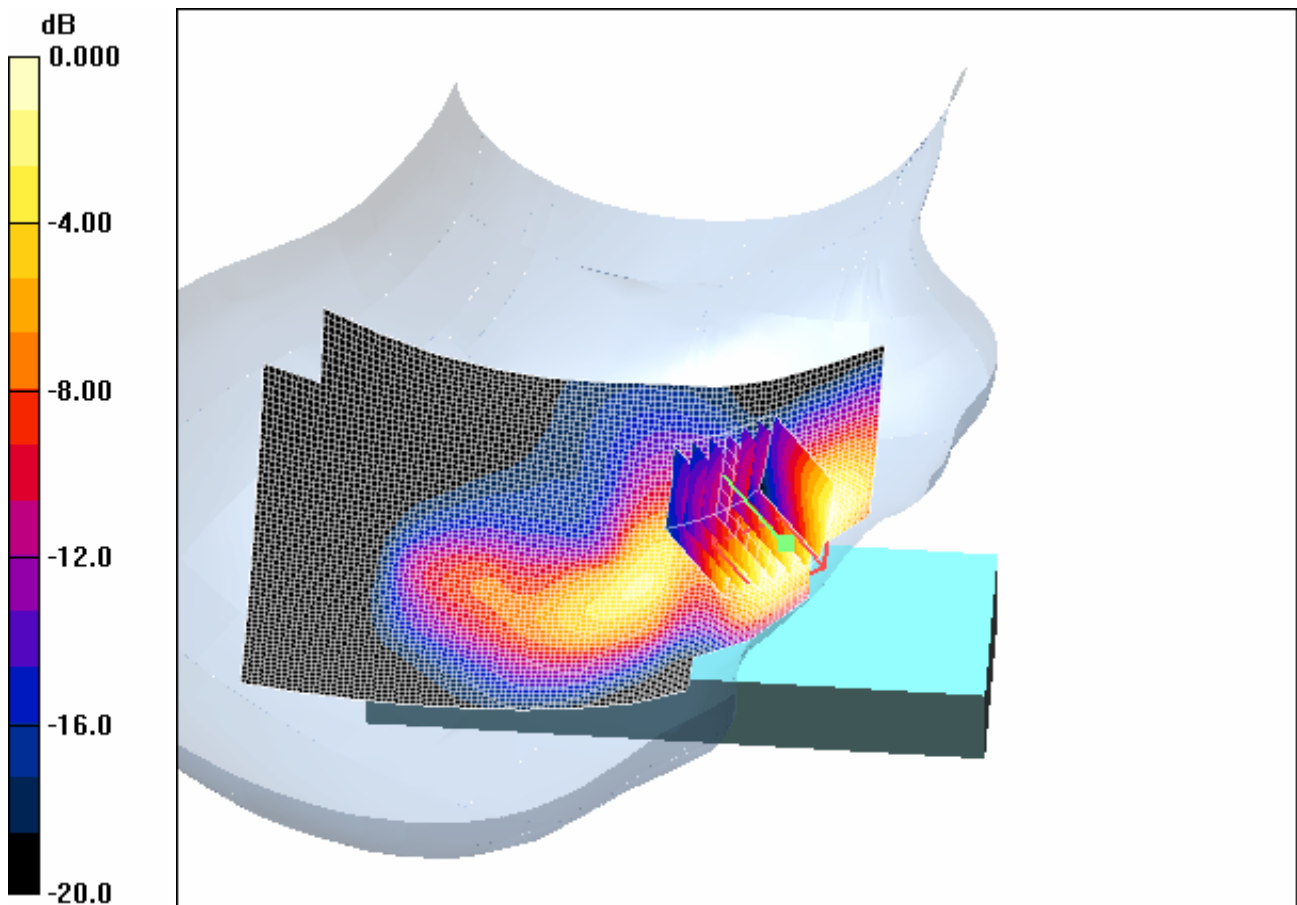

0 dB = 0.379mW/g

4.25RightHandSide-Tilt-PCS1900-Low

Date/Time: 2006-7-11 13:24:26

Test Laboratory: SGS-GSM

FCC-OET65-RightHandSide-Tilt-PCS1900-Low

DUT: GSM10006708M; Type: Head; Serial: 01090100000207-8

Communication System: PCS1900-GSM Mode; Frequency: 1850.2 MHz; Duty Cycle: 1:8.3

Medium: HSL1900 Medium parameters used: $f = 1850.2$ MHz; $\sigma = 1.42$ mho/m; $r = 40.5$; $\rho = 1000$ kg/m³

Phantom section: Right Section

Measurement Standard: DASY4 (High Precision Assessment)

DASY4 Configuration:

- Probe: ES3DV3 - SN3088; ConvF(4.93, 4.93, 4.93); Calibrated: 2005-9-13
- Sensor-Surface: 4mm (Mechanical Surface Detection)
- Electronics: DAE3 Sn569; Calibrated: 2005-11-17
- Phantom: SAM 12; Type: SAM V4.0; Serial: TP-1283
- Measurement SW: DASY4, V4.6 Build 23; Postprocessing SW: SEMCAD, V1.8 Build 160

Tilt position - Low/Area Scan (71x111x1): Measurement grid: dx=15mm, dy=15mm

Maximum value of SAR (interpolated) = 0.068 mW/g

Tilt position - Low/Zoom Scan (7x7x7) (7x7x7)/Cube 0: Measurement grid: dx=5mm, dy=5mm, dz=5mm

Reference Value = 6.10 V/m; Power Drift = -0.133 dB

Peak SAR (extrapolated) = 0.091 W/kg

SAR(1 g) = 0.056 mW/g; SAR(10 g) = 0.032 mW/g

Maximum value of SAR (measured) = 0.063 mW/g

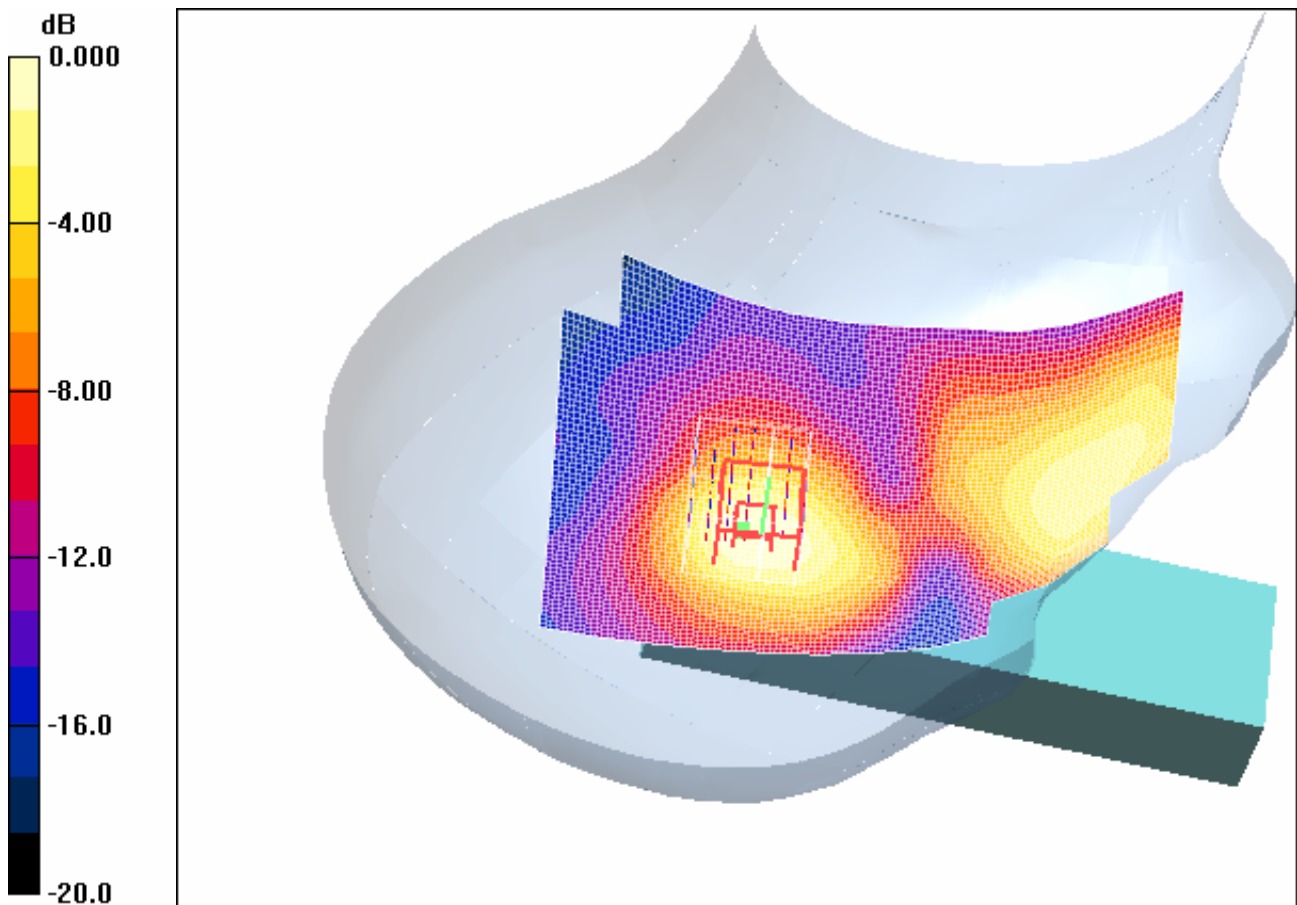

0 dB = 0.063mW/g

4.26RightHandSide-Tilt-PCS1900-Middle

Date/Time: 2006-7-11 13:59:18

Test Laboratory: SGS-GSM

FCC-OET65-RightHandSide-Tilt-PCS1900-Mid

DUT: GSM10006708M; Type: Head; Serial: 01090100000207-8

Communication System: PCS1900-GSM Mode; Frequency: 1880 MHz;Duty Cycle: 1:8.3

Medium: HSL1900 Medium parameters used: $f = 1880$ MHz; $\sigma = 1.44$ mho/m; $\epsilon_r = 40.3$; $\rho = 1000$ kg/m³

Phantom section: Right Section

Measurement Standard: DASY4 (High Precision Assessment)

DASY4 Configuration:

- Probe: ES3DV3 - SN3088; ConvF(4.93, 4.93, 4.93); Calibrated: 2005-9-13
- Sensor-Surface: 4mm (Mechanical Surface Detection)
- Electronics: DAE3 Sn569; Calibrated: 2005-11-17
- Phantom: SAM 12; Type: SAM V4.0; Serial: TP-1283
- Measurement SW: DASY4, V4.6 Build 23; Postprocessing SW: SEMCAD, V1.8 Build 160

Tilt position - Middle/Area Scan (71x111x1): Measurement grid: dx=15mm, dy=15mm

Maximum value of SAR (interpolated) = 0.069 mW/g

Tilt position - Middle/Zoom Scan (7x7x7)/Cube 0: Measurement grid: dx=5mm, dy=5mm, dz=5mm

Reference Value = 6.17 V/m; Power Drift = -0.080 dB

Peak SAR (extrapolated) = 0.094 W/kg

SAR(1 g) = 0.057 mW/g; SAR(10 g) = 0.032 mW/g

Maximum value of SAR (measured) = 0.063 mW/g

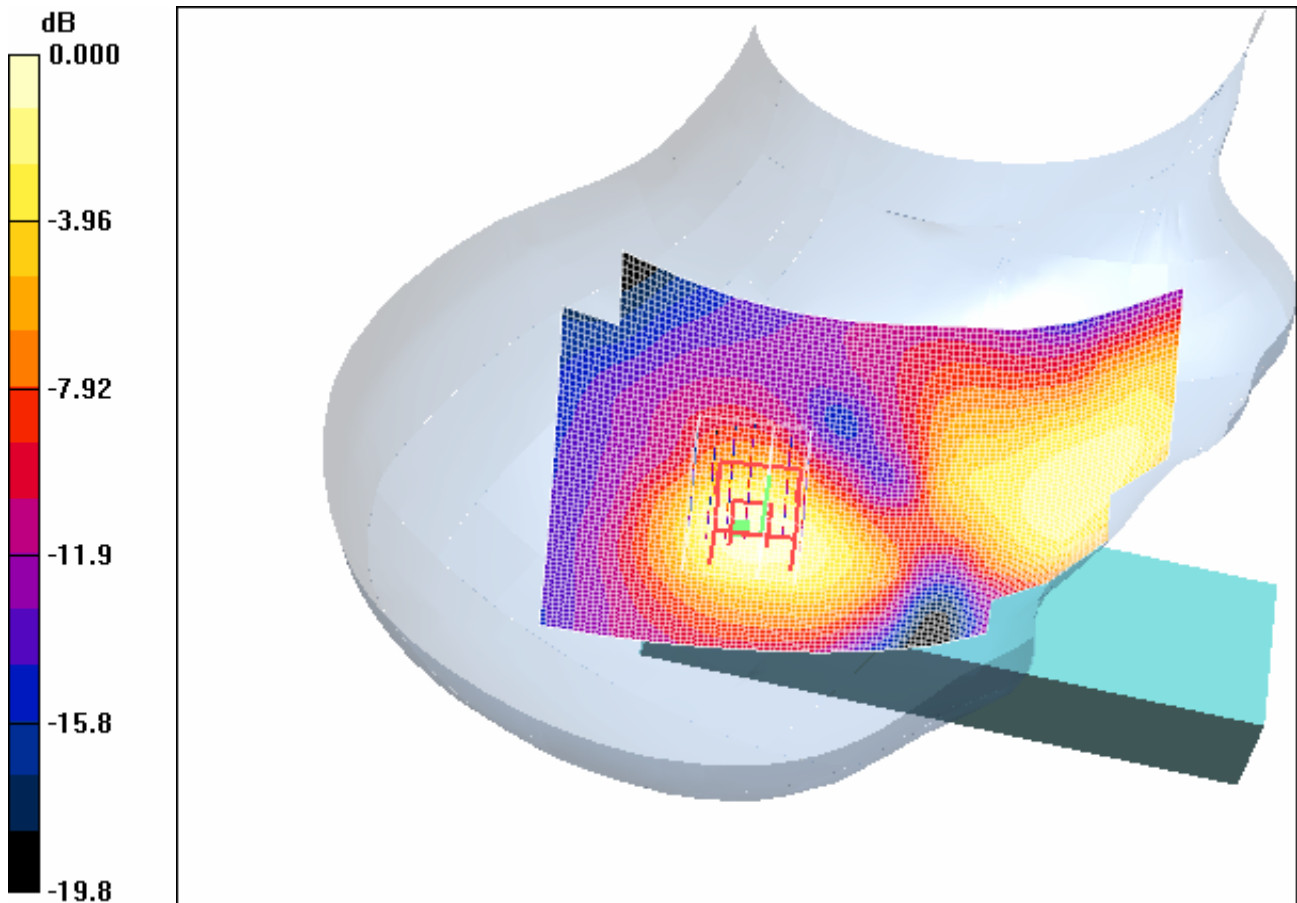

0 dB = 0.063mW/g

4.27RightHandSide-Tilt-PCS1900-High

Date/Time: 2006-7-11 14:34:18

Test Laboratory: SGS-GSM

FCC-OET65-RightHandSide-Tilt-PCS1900-High

DUT: GSM10006708M; Type: Head; Serial: 01090100000207-8

Communication System: PCS1900-GSM Mode; Frequency: 1909.8 MHz;Duty Cycle: 1:8.3

Medium: HSL1900 Medium parameters used: $f = 1909.8 \text{ MHz}$; $\sigma = 1.47 \text{ mho/m}$; $\epsilon_r = 40$; $\rho = 1000 \text{ kg/m}^3$

Phantom section: Right Section

Measurement Standard: DASY4 (High Precision Assessment)

DASY4 Configuration:

- Probe: ES3DV3 - SN3088; ConvF(4.93, 4.93, 4.93); Calibrated: 2005-9-13
- Sensor-Surface: 4mm (Mechanical Surface Detection)
- Electronics: DAE3 Sn569; Calibrated: 2005-11-17
- Phantom: SAM 12; Type: SAM V4.0; Serial: TP-1283
- Measurement SW: DASY4, V4.6 Build 23; Postprocessing SW: SEMCAD, V1.8 Build 160

Tilt position - High/Area Scan (71x111x1): Measurement grid: dx=15mm, dy=15mm

Maximum value of SAR (interpolated) = 0.061 mW/g

Tilt position - High/Zoom Scan (7x7x7) (7x7x7)/Cube 0: Measurement grid: dx=5mm, dy=5mm, dz=5mm

Reference Value = 5.81 V/m; Power Drift = -0.044 dB

Peak SAR (extrapolated) = 0.084 W/kg

SAR(1 g) = 0.050 mW/g; SAR(10 g) = 0.027 mW/g

Maximum value of SAR (measured) = 0.056 mW/g

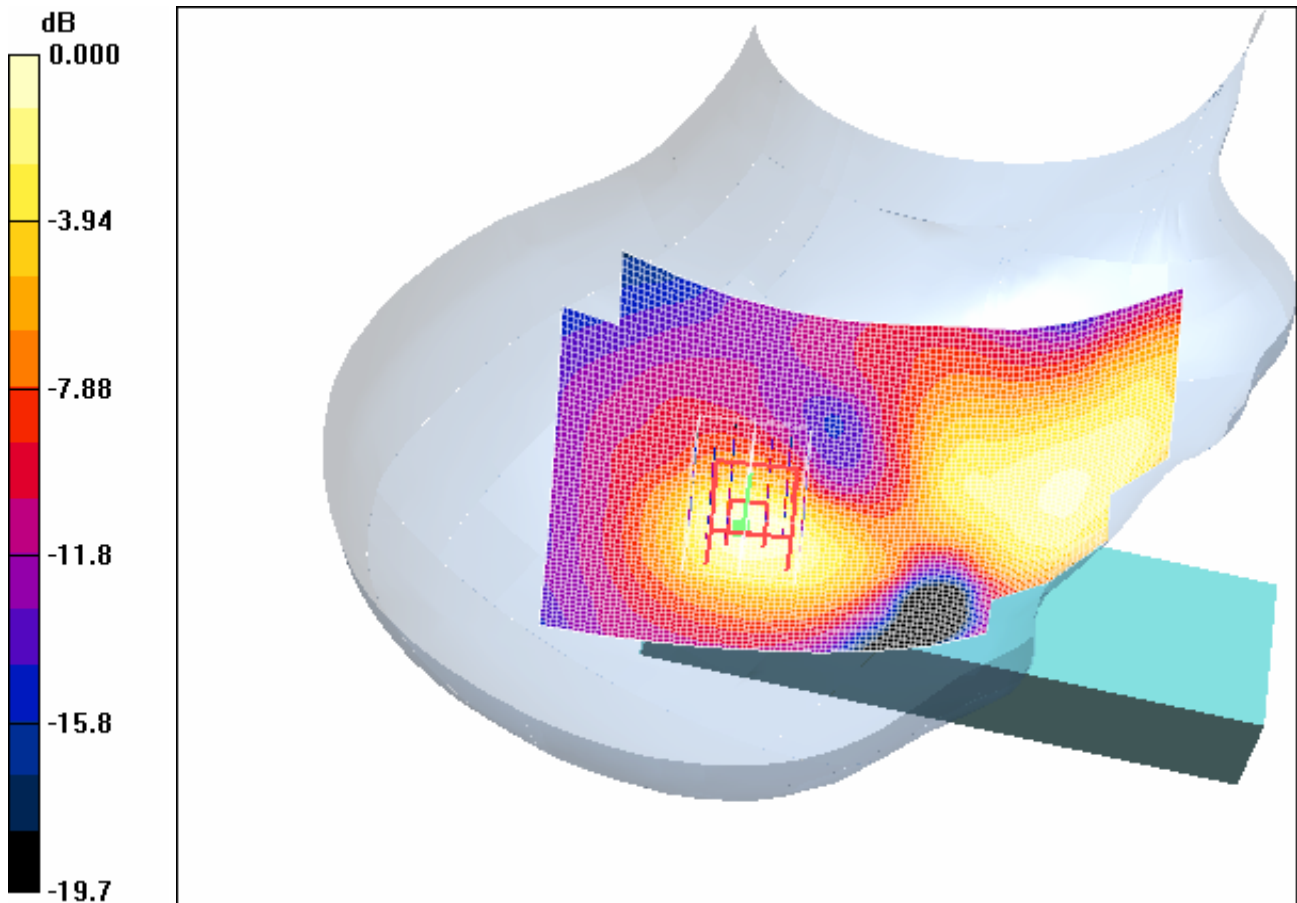

0 dB = 0.056mW/g

4.28Body-Worn-PCS1900-GPRS-Low

Date/Time: 2006-7-13 11:04:01

Test Laboratory: SGS-GSM

FCC-OET65-Body-Worn-PCS1900-GPRS-2cm-Low

DUT: GSM10006708M; Type: Body; Serial: 01090100000207-8

Communication System: PCS1900-GPRS Mode; Frequency: 1850.2 MHz; Duty Cycle: 1:4

Medium: HSL1900-Body Medium parameters used: $f = 1850.2$ MHz; $\sigma = 1.49$ mho/m; $\epsilon_r = 51.6$; $\rho = 1000$ kg/m³

Phantom section: Flat Section

Measurement Standard: DASY4 (High Precision Assessment)

DASY4 Configuration:

- Probe: ES3DV3 - SN3088; ConvF(4.53, 4.53, 4.53); Calibrated: 2005-9-13
- Sensor-Surface: 4mm (Mechanical Surface Detection)
- Electronics: DAE3 Sn569; Calibrated: 2005-11-17
- Phantom: SAM 12; Type: SAM V4.0; Serial: TP-1283
- Measurement SW: DASY4, V4.6 Build 23; Postprocessing SW: SEMCAD, V1.8 Build 160

Body Worn - Low/Area Scan (51x91x1): Measurement grid: dx=15mm, dy=15mm

Maximum value of SAR (interpolated) = 0.663 mW/g

Body Worn - Low/Zoom Scan (7x7x7) (7x7x7)/Cube 0: Measurement grid: dx=5mm, dy=5mm, dz=5mm

Reference Value = 16.0 V/m; Power Drift = -0.250 dB

Peak SAR (extrapolated) = 0.946 W/kg

SAR(1 g) = 0.595 mW/g; SAR(10 g) = 0.360 mW/g

Maximum value of SAR (measured) = 0.645 mW/g

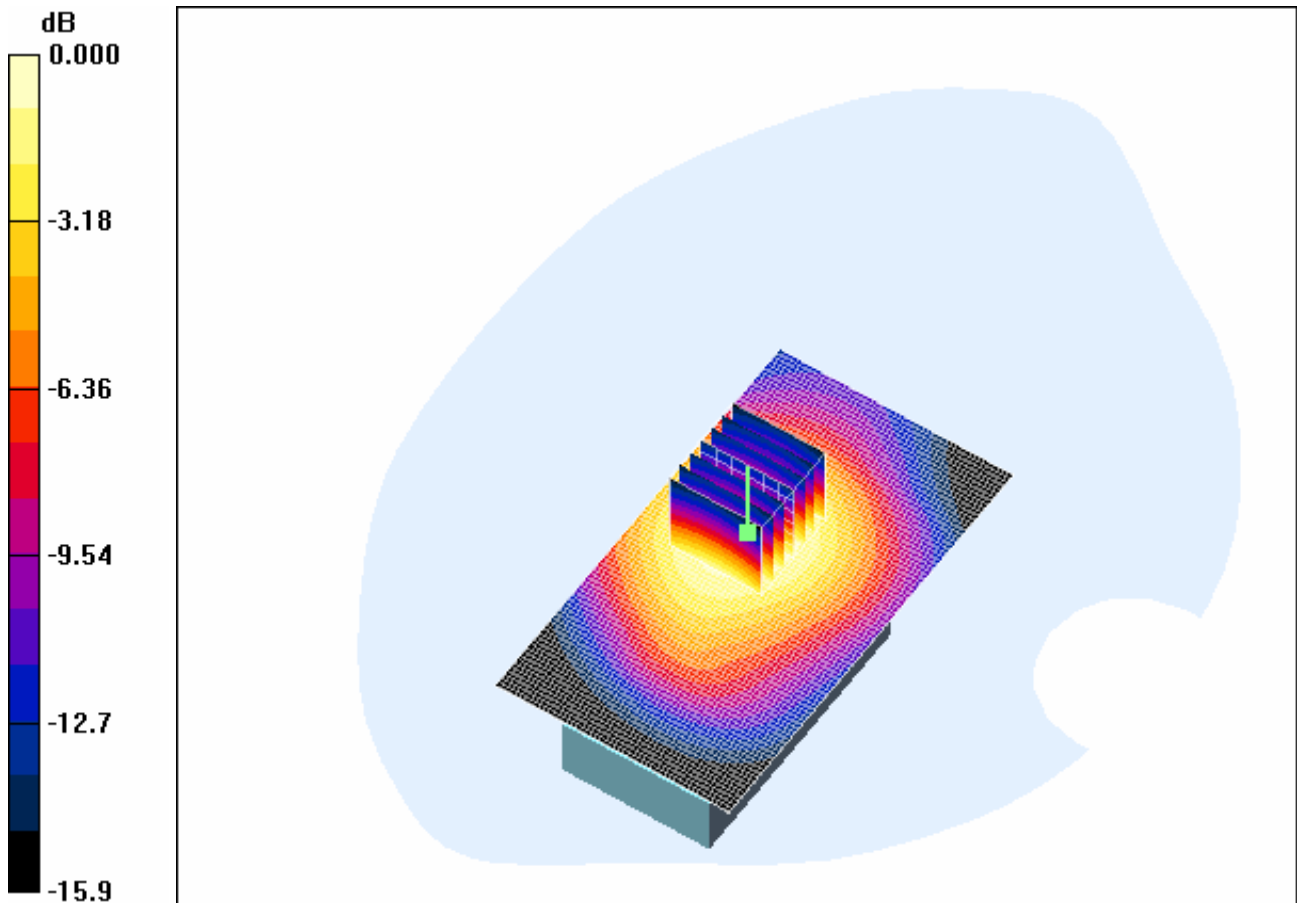

0 dB = 0.645mW/g

4.29Body-Worn-PCS1900-GPRS-Middle

Date/Time: 2006-7-13 11:27:03

Test Laboratory: SGS-GSM

FCC-OET65-Body-Worn-PCS1900-GPRS-2cm-Mid

DUT: GSM10006708M; Type: Body; Serial: 01090100000207-8

Communication System: PCS1900-GPRS Mode; Frequency: 1880 MHz; Duty Cycle: 1:4

Medium: HSL1900-Body Medium parameters used: $f = 1880$ MHz; $\sigma = 1.52$ mho/m; $\epsilon_r = 51.5$; $\rho = 1000$ kg/m³

Phantom section: Flat Section

Measurement Standard: DASY4 (High Precision Assessment)

DASY4 Configuration:

- Probe: ES3DV3 - SN3088; ConvF(4.53, 4.53, 4.53); Calibrated: 2005-9-13
- Sensor-Surface: 4mm (Mechanical Surface Detection)
- Electronics: DAE3 Sn569; Calibrated: 2005-11-17
- Phantom: SAM 12; Type: SAM V4.0; Serial: TP-1283
- Measurement SW: DASY4, V4.6 Build 23; Postprocessing SW: SEMCAD, V1.8 Build 160

Body Worn - Middle/Area Scan (51x91x1): Measurement grid: dx=15mm, dy=15mm

Maximum value of SAR (interpolated) = 0.622 mW/g

Body Worn - Middle/Zoom Scan (7x7x7)/Cube 0: Measurement grid: dx=5mm, dy=5mm, dz=5mm

Reference Value = 16.3 V/m; Power Drift = -0.109 dB

Peak SAR (extrapolated) = 0.901 W/kg

SAR(1 g) = 0.562 mW/g; SAR(10 g) = 0.337 mW/g

Maximum value of SAR (measured) = 0.609 mW/g

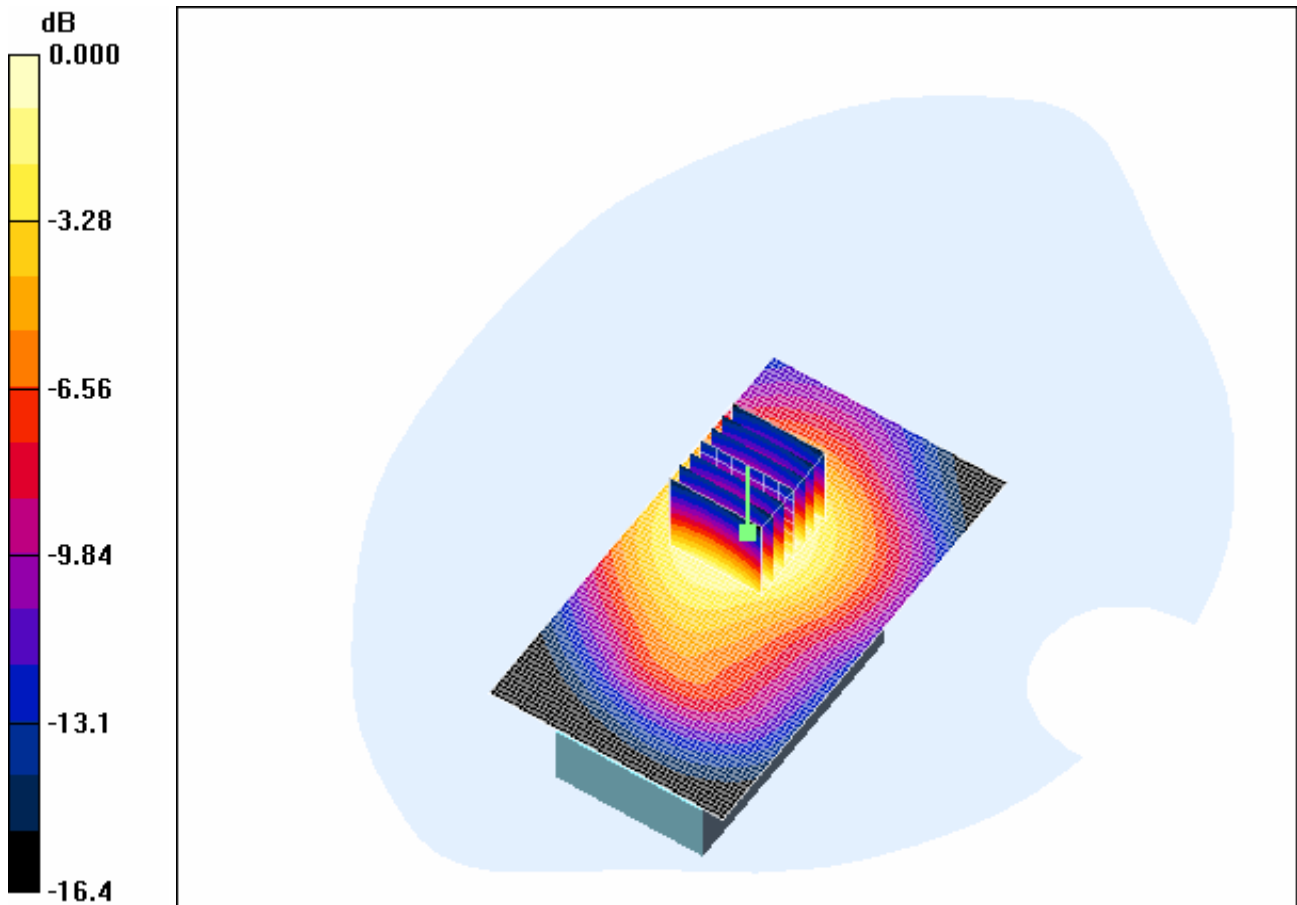

0 dB = 0.609mW/g

4.30Body-Worn-PCS1900-GPRS-High

Date/Time: 2006-7-13 11:55:36

Test Laboratory: SGS-GSM

FCC-OET65-Body-Worn-PCS1900-GPRS-2cm-High

DUT: GSM10006708M; Type: Body; Serial: 01090100000207-8

Communication System: PCS1900-GPRS Mode; Frequency: 1909.8 MHz; Duty Cycle: 1:4

Medium: HSL1900-Body Medium parameters used: $f = 1909.8 \text{ MHz}$; $\sigma = 1.55 \text{ mho/m}$; $\epsilon_r = 51.5$; $\rho = 1000 \text{ kg/m}^3$

Phantom section: Flat Section

Measurement Standard: DASY4 (High Precision Assessment)

DASY4 Configuration:

- Probe: ES3DV3 - SN3088; ConvF(4.53, 4.53, 4.53); Calibrated: 2005-9-13
- Sensor-Surface: 4mm (Mechanical Surface Detection)
- Electronics: DAE3 Sn569; Calibrated: 2005-11-17
- Phantom: SAM 12; Type: SAM V4.0; Serial: TP-1283
- Measurement SW: DASY4, V4.6 Build 23; Postprocessing SW: SEMCAD, V1.8 Build 160

Body Worn - High/Area Scan (51x91x1): Measurement grid: dx=15mm, dy=15mm

Maximum value of SAR (interpolated) = 0.455 mW/g

Body Worn - High/Zoom Scan (7x7x7) (7x7x7)/Cube 0: Measurement grid: dx=5mm, dy=5mm, dz=5mm

Reference Value = 14.7 V/m; Power Drift = -0.023 dB

Peak SAR (extrapolated) = 0.656 W/kg

SAR(1 g) = 0.412 mW/g; SAR(10 g) = 0.246 mW/g

Maximum value of SAR (measured) = 0.446 mW/g

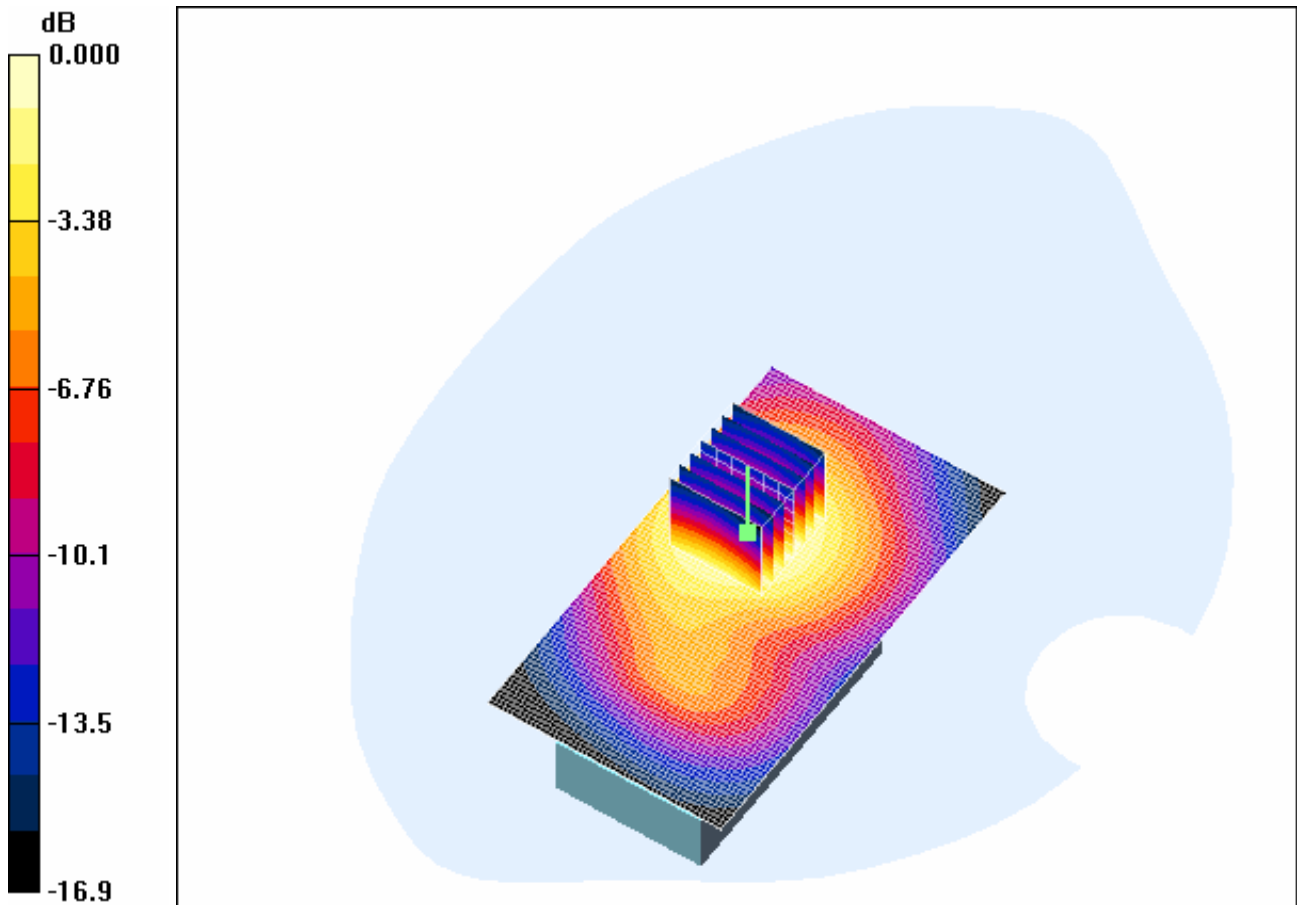

0 dB = 0.446mW/g

Appendix

1. Photographs of Test Setup

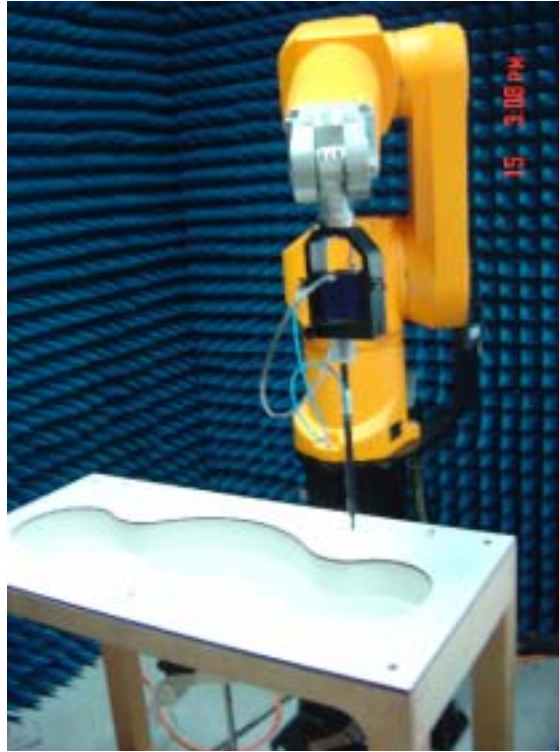

Fig.1 Photograph of the SAR measurement System

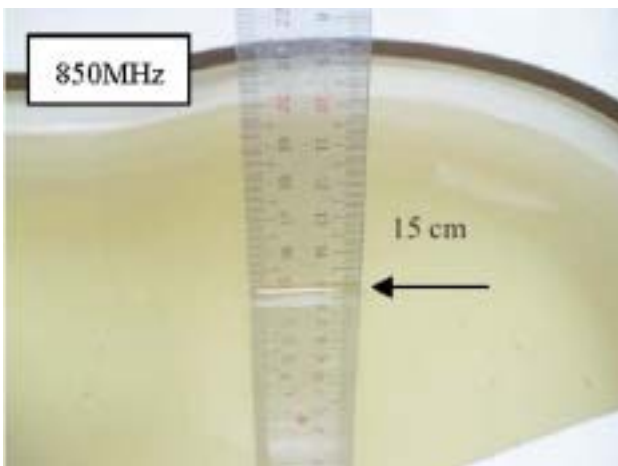

Fig.2 Photograph of the Tissue Simulant Fluid Liquid depth 15cm for Left-Head Side

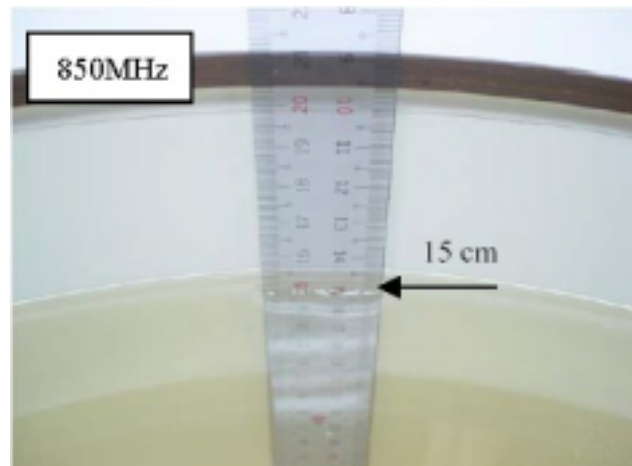

Fig.3 Photograph of the Tissue Simulant Liquid depth 15cm for Body-Worn

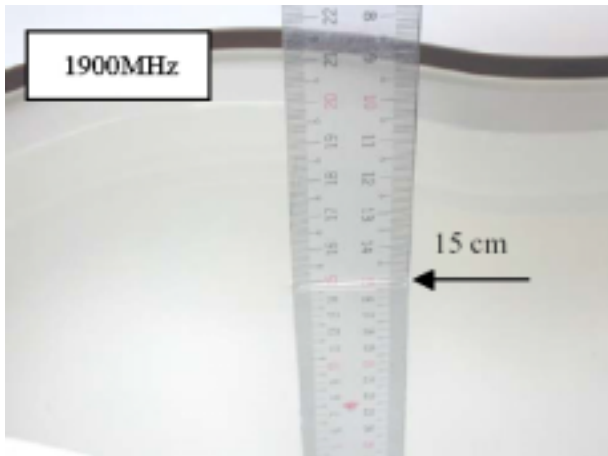

Fig.4 Photograph of the Tissue Simulant Fluid Liquid depth 15cm for Right-Head Side

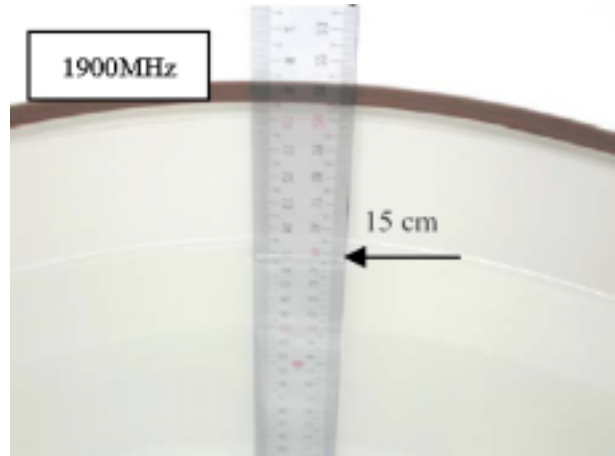

Fig.5 Photograph of the Tissue Simulant Liquid depth 15cm for Body-Worn



Fig.6 Photograph of the Left Hand Side Cheek status

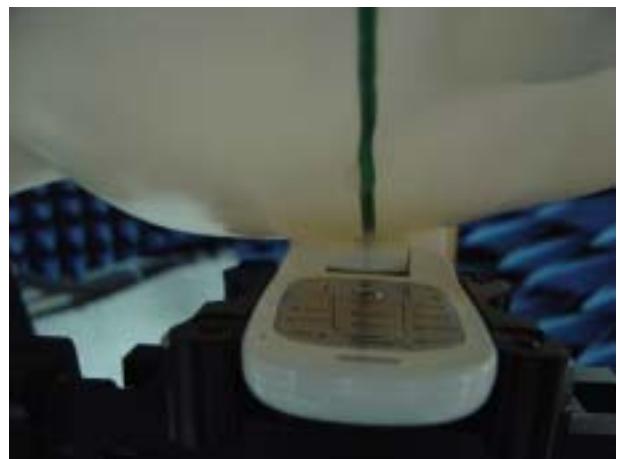

Fig.7 Photograph of the Left Hand Side Tilt status



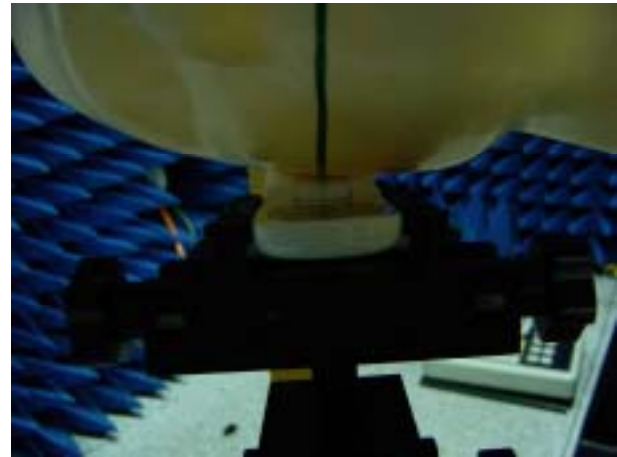

Fig.8 Photograph of the Right Hand Side Cheek status

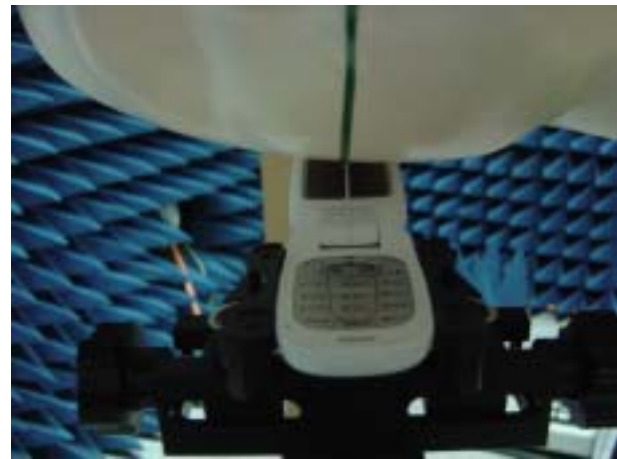

Fig.9 Photograph of the Right Hand Side Tilt status

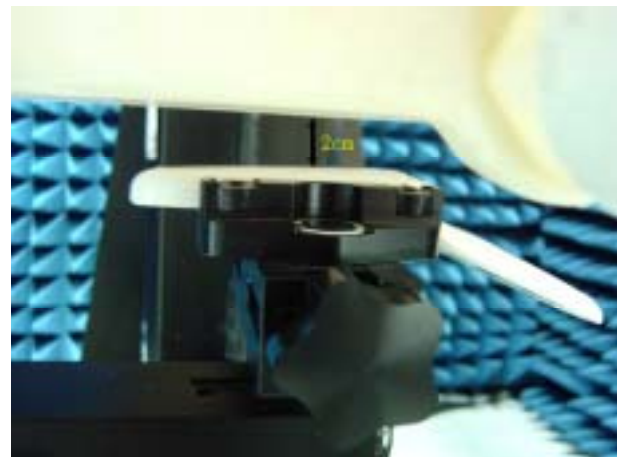

Fig.10 Photograph of the BodyWorn status

2. Photographs of the EUT



Fig.11 Front View



Fig.12 Back View

3. Photographs of the battery



Fig.13 Front view of battery



Fig.14 Back view of battery

4. Photograph of the charger



Fig.15 Charger

5. Probe Calibration certificate

Calibration Laboratory of
Schmid & Partner
Engineering AG
Zeughausstrasse 43, 8004 Zurich, Switzerland



S Schweizerischer Kalibrierdienst
S Service suisse d'étalonnage
C Servizio svizzero di taratura
S Swiss Calibration Service

Accredited by the Swiss Federal Office of Metrology and Accreditation
The Swiss Accreditation Service is one of the signatories to the EA
Multilateral Agreement for the recognition of calibration certificates

Accreditation No.: SCS 108

Client: SGS-CSTX (MTT)

Certificate No: ES3-3088_Sep05

CALIBRATION CERTIFICATE

Object: ES3DV3 - SN.3088

Calibration procedure(s):
QA CAL-01.v5
Calibration procedure for dosimetric E-field probes

Calibration date: September 13, 2005

Condition of the calibrated item: In Tolerance

This calibration certificate documents the traceability to national standards, which realize the physical units of measurements (SI).
The measurements and the uncertainties with confidence probability are given on the following pages and are part of this certificate.

All calibrations have been conducted in the closed laboratory facility; environment temperature ($22 \pm 3/^\circ\text{C}$) and humidity $< 75\%$.

Calibration Equipment used (M&TE critical for calibration)

Primary Standards	ID #	Cal Date (Calibrated by, Certificate No.)	Scheduled Calibration
Power meter E44198	0B41293874	3-May-05 (METAS, No. 251-00498)	May-06
Power sensor E4412A	MY41485277	3-May-05 (METAS, No. 251-00498)	May-06
Power sensor E4412A	MY41485087	3-May-05 (METAS, No. 251-00498)	May-06
Reference 3 dB Attenuator	SN: S5054 (30)	11-Aug-05 (METAS, No. 251-00499)	Aug-06
Reference 20 dB Attenuator	SN: S5066 (20b)	3-May-05 (METAS, No. 251-00497)	May-06
Reference 30 dB Attenuator	SN: S5129 (30b)	11-Aug-05 (METAS, No. 251-00500)	Aug-06
Reference Probe ES3DV2	SN: 3013	7-Jan-05 (SPEAG, No. ES3-3013_Jan05)	Jan-06
DAE4	SN: 654	29-Nov-04 (SPEAG, No. DAE4-654_Nov04)	Nov-05

Secondary Standards	ID #	Check Date (in house)	Scheduled Check
RF generator HP 8648C	US3262UD1700	4-Aug-05 (SPEAG, in house check Dec-03)	In house check: Dec-05
Network Analyzer HP 8733C	US37360585	18-Oct-01 (SPEAG, in house check Nov-04)	In house check: Nov-05

Calibrated by:	Name	Function	Signature
	Nico Vetterli	Laboratory Technician	
Approved by:	Kajsa Pokovic	Technical Manager	

Issued: September 15, 2005

This calibration certificate shall not be reproduced except in full without written approval of the laboratory.

Calibration Laboratory of
Schmid & Partner
Engineering AG
Zeughausstrasse 43, 8004 Zurich, Switzerland



S Schweizerischer Kalibrierdienst
C Service suisse d'étalonnage
S Servizio svizzero di taratura
S Swiss Calibration Service

Accredited by the Swiss Federal Office of Metrology and Accreditation
The Swiss Accreditation Service is one of the signatories to the EA
Multilateral Agreement for the recognition of calibration certificates

Accreditation No.: **SCS 108**

Glossary:

TSL	tissue simulating liquid
NORM _{x,y,z}	sensitivity in free space
ConF	sensitivity in TSL / NORM _{x,y,z}
DCP	diode compression point
Polarization φ	φ rotation around probe axis
Polarization β	β rotation around an axis that is in the plane normal to probe axis (at measurement center), i.e., $\beta = 0$ is normal to probe axis

Calibration is Performed According to the Following Standards:

- IEEE Std 1528-2003, "IEEE Recommended Practice for Determining the Peak Spatial-Averaged Specific Absorption Rate (SAR) in the Human Head from Wireless Communications Devices: Measurement Techniques", December 2003
- CENELEC EN 50361, "Basic standard for the measurement of Specific Absorption Rate related to human exposure to electromagnetic fields from mobile phones (300 MHz - 3 GHz), July 2001

Methods Applied and Interpretation of Parameters:

- NORM_{x,y,z}**: Assessed for E-field polarization $\beta = 0$ ($f \leq 900$ MHz in TEM-cell; $f > 1800$ MHz: R22 waveguide). NORM_{x,y,z} are only intermediate values, i.e., the uncertainties of NORM_{x,y,z} does not affect the E²-field uncertainty inside TSL (see below ConF).
- NORM(f)_{x,y,z} = NORM_{x,y,z} * frequency_response** (see Frequency Response Chart). This linearization is implemented in DASY4 software versions later than 4.2. The uncertainty of the frequency response is included in the stated uncertainty of ConF.
- DCP_{x,y,z}**: DCP are numerical linearization parameters assessed based on the data of power sweep (no uncertainty required). DCP does not depend on frequency nor media.
- ConF and Boundary Effect Parameters**: Assessed in flat phantom using E-field (or Temperature Transfer Standard for $f \leq 800$ MHz) and inside waveguide using analytical field distributions based on power measurements for $f > 800$ MHz. The same setups are used for assessment of the parameters applied for boundary compensation (alpha, depth) of which typical uncertainty values are given. These parameters are used in DASY4 software to improve probe accuracy close to the boundary. The sensitivity in TSL corresponds to NORM_{x,y,z} * ConF whereby the uncertainty corresponds to that given for ConF. A frequency dependent ConF is used in DASY version 4.4 and higher which allows extending the validity from ± 50 MHz to ± 100 MHz.
- Spherical Isotropy (3D deviation from isotropy)**: in a field of low gradients realized using a flat phantom exposed by a patch antenna.
- Sensor Offset**: The sensor offset corresponds to the offset of virtual measurement center from the probe tip (on probe axis). No tolerance required.

ES3DV3 SN:3088

September 13, 2005

Probe ES3DV3

SN:3088

Manufactured:	July 20, 2005
Calibrated:	September 13, 2005

Calibrated for DASY Systems

(Note: non-compatible with DASY2 system!)

ES3DV3 SN:3088

September 13, 2005

DASY - Parameters of Probe: ES3DV3 SN:3088**Sensitivity in Free Space^A****Diode Compression^B**

NormX	1.32 ± 10.1%	$\mu\text{V}/(\text{V}/\text{m})^2$	DCP X	95 mV
NormY	1.24 ± 10.1%	$\mu\text{V}/(\text{V}/\text{m})^2$	DCP Y	95 mV
NormZ	1.23 ± 10.1%	$\mu\text{V}/(\text{V}/\text{m})^2$	DCP Z	95 mV

Sensitivity in Tissue Simulating Liquid (Conversion Factors)

Please see Page 8.

Boundary Effect**TSL 900 MHz Typical SAR gradient: 5 % per mm**

Sensor Center to Phantom Surface Distance		3.0 mm	4.0 mm
SAR ₉₀ [%]	Without Correction Algorithm	5.8	2.7
SAR ₉₀ [%]	With Correction Algorithm	0.0	0.1

TSL 1750 MHz Typical SAR gradient: 10 % per mm

Sensor Center to Phantom Surface Distance		3.0 mm	4.0 mm
SAR ₉₀ [%]	Without Correction Algorithm	7.6	4.5
SAR ₉₀ [%]	With Correction Algorithm	0.1	0.2

Sensor OffsetProbe Tip to Sensor Center **2.0 mm**

The reported uncertainty of measurement is stated as the standard uncertainty of measurement multiplied by the coverage factor $k=2$, which for a normal distribution corresponds to a coverage probability of approximately 95%.

^A The uncertainties of NormX,Y,Z do not affect the E^2 -field uncertainty inside TSL (see Page 8).

^B Numerical linearization parameter: uncertainty not required.

ES3DV3 SN:3088

September 13, 2005

Frequency Response of E-Field

(TEM-Cell:if1110 EXX, Waveguide: R22)

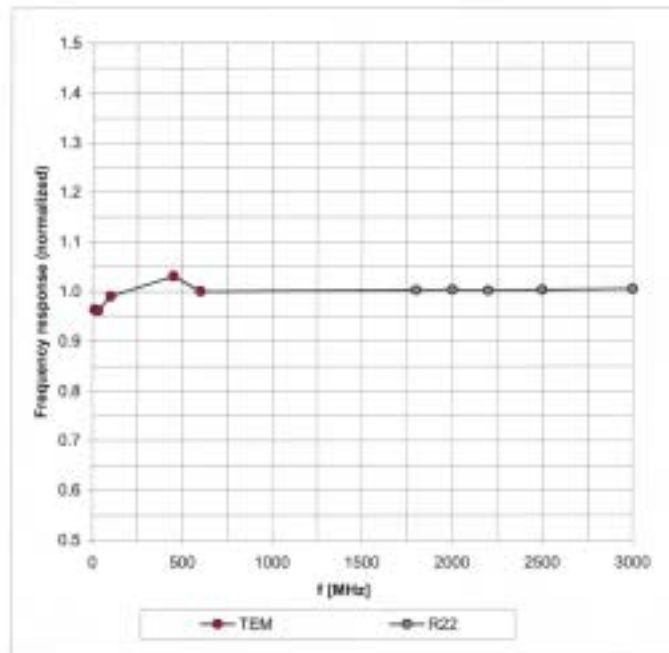

Uncertainty of Frequency Response of E-field: $\pm 6.3\%$ (k=2)

E53DV3 SN:3088

September 13, 2005

Receiving Pattern (ϕ), $\theta = 0^\circ$

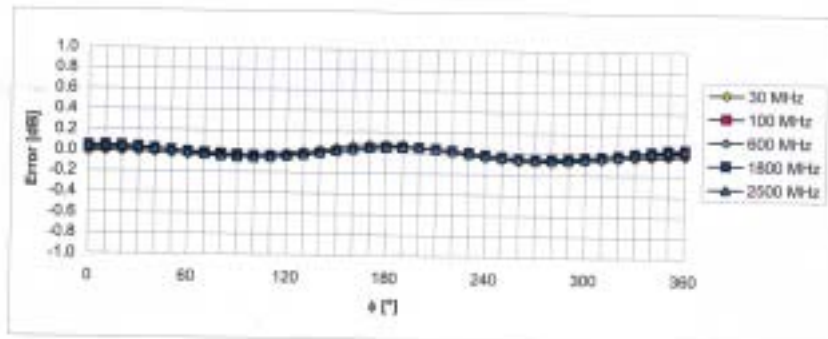
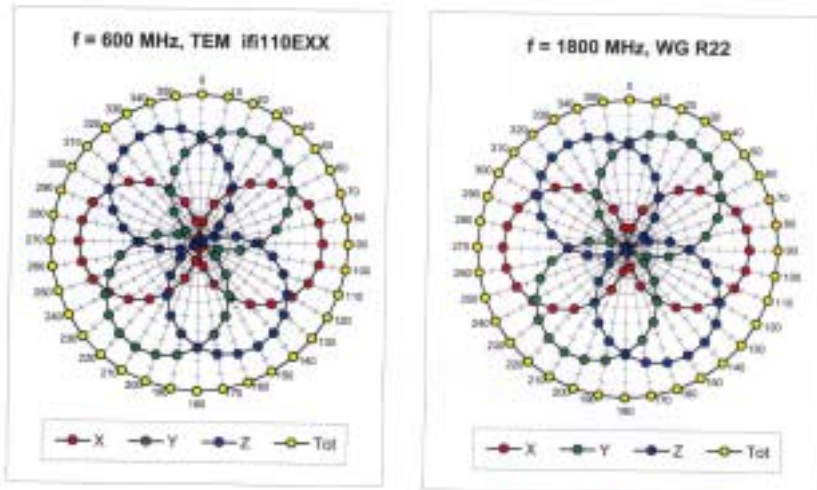

Uncertainty of Axial Isotropy Assessment: $\pm 0.5\%$ (k=2)

ES3DV3 SN:3088

September 13, 2005

Dynamic Range $f(\text{SAR}_{\text{head}})$ (Waveguide R22, $f = 1800$ MHz)

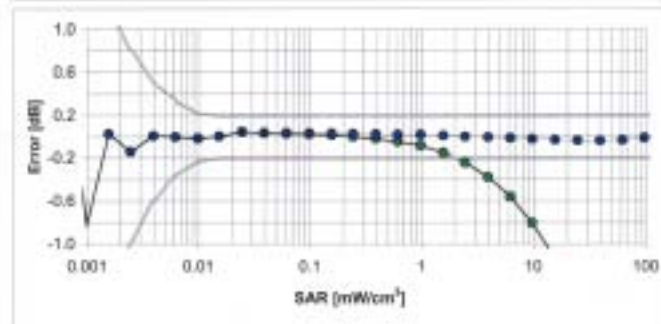
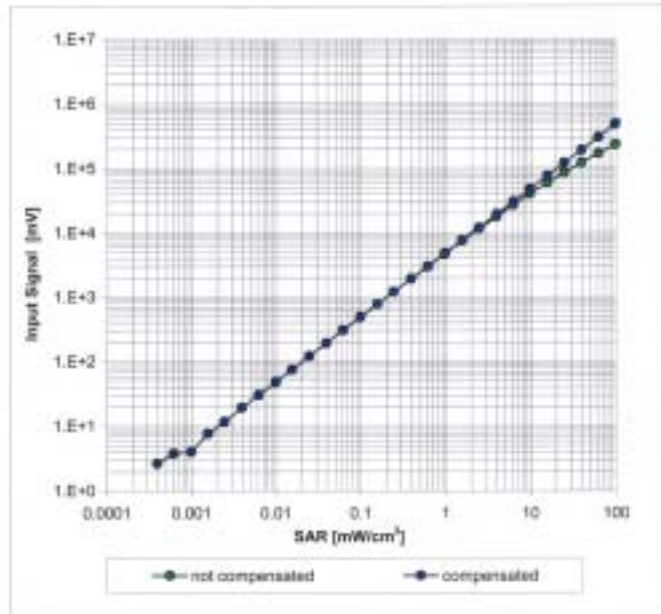

Uncertainty of Linearity Assessment: $\pm 0.6\%$ ($k=2$)

ES3DV3 SN:3088

September 13, 2005

Conversion Factor Assessment

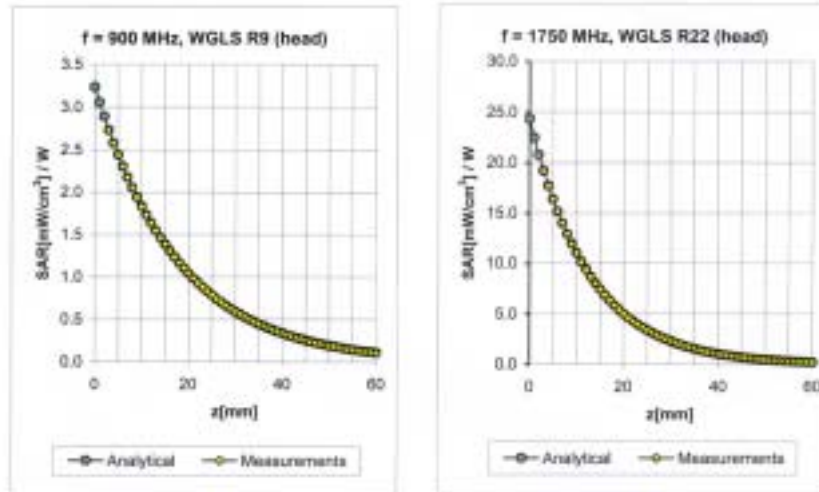

f [MHz]	Validity [MHz] ²	TSL	Permittivity	Conductivity	Alpha	Depth	ConvF	Uncertainty
900	± 50 / ± 100	Head	41.5 ± 5%	0.97 ± 5%	0.47	1.40	5.91 ± 11.0% (k=2)	
1750	± 50 / ± 100	Head	40.1 ± 5%	1.37 ± 5%	0.24	2.39	4.97 ± 11.0% (k=2)	
1900	± 50 / ± 100	Head	40.0 ± 5%	1.40 ± 5%	0.27	2.28	4.93 ± 11.0% (k=2)	
2000	± 50 / ± 100	Head	40.0 ± 5%	1.40 ± 5%	0.25	2.34	4.87 ± 11.0% (k=2)	
900	± 50 / ± 100	Body	55.0 ± 5%	1.05 ± 5%	0.61	1.25	5.83 ± 11.0% (k=2)	
1750	± 50 / ± 100	Body	53.4 ± 5%	1.49 ± 5%	0.28	2.53	4.61 ± 11.0% (k=2)	
1900	± 50 / ± 100	Body	53.3 ± 5%	1.52 ± 5%	0.28	2.57	4.53 ± 11.0% (k=2)	
2000	± 50 / ± 100	Body	53.3 ± 5%	1.52 ± 5%	0.32	2.11	4.47 ± 11.0% (k=2)	

² The validity of a 100 MHz only applies for DASY v4.4 and higher (see Page 2). The uncertainty is the RSS of the ConvF uncertainty at calibration frequency and the uncertainty for the indicated frequency band.

ES3DV3 SN:3088

September 13, 2005

Deviation from Isotropy in HSL

Error (ϕ , θ), $f = 900$ MHz

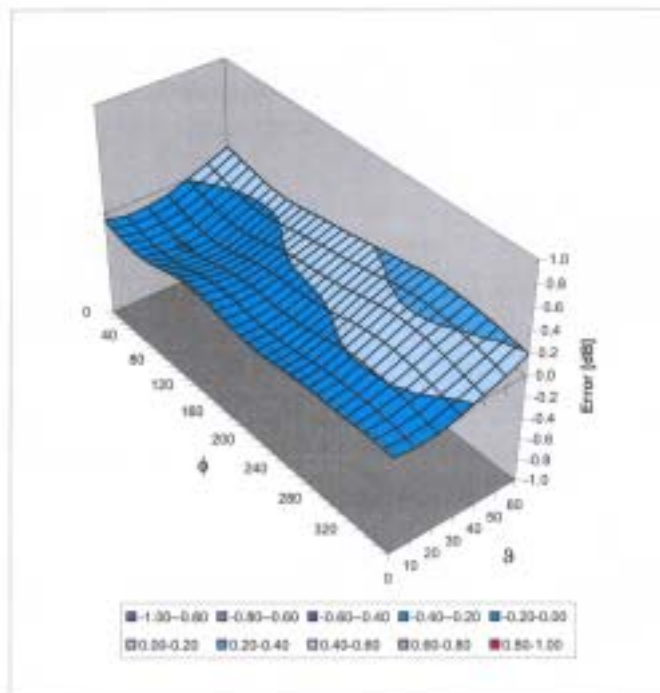

Uncertainty of Spherical Isotropy Assessment: $\pm 2.6\%$ ($k=2$)

6. Uncertainty analysis

Error Description	Tol. (± %)	Prob. dist.	Div.	(c_1) (1g)	(c_2) (10g)	Std. unc. (± %)		(v_i)
Std. unc. (1g)		Std. unc. (10g)						
Measurement System								
Probe Calibration	4.8	N	1	1	1	4.8	4.8	∞
Axial Isotropy	4.7	R	$\sqrt{3}$	1	1	2.7	2.7	∞
Hemispherical Isotropy	0	R	$\sqrt{3}$	1	1	0	0	∞
Boundary Effects	1.0	R	$\sqrt{3}$	1	1	0.6	0.6	∞
Linearity	4.7	R	$\sqrt{3}$	1	1	2.7	2.7	∞
System Detection Limit	1.0	R	$\sqrt{3}$	1	1	0.6	0.6	∞
Readout Electronics	1.0	N	1	1	1	1.0	1.0	∞
Response Time	0	R	$\sqrt{3}$	1	1	0	0	∞
Integration Time	0	R	$\sqrt{3}$	1	1	0	0	∞
RF Ambient Conditions	3.0	R	$\sqrt{3}$	1	1	1.7	1.7	∞
Probe Positioner	0.4	R	$\sqrt{3}$	1	1	0.2	0.2	∞
Probe Positioning	2.9	R	$\sqrt{3}$	1	1	1.7	1.7	∞
Algorithms for Max. SAR Eval.	1.0	R	$\sqrt{3}$	1	1	0.6	0.6	∞
Dipole								
Dipole Axis to Liquid Distance	2.0	R	$\sqrt{3}$	1	1	1.2	1.2	∞
Input power and SAR drift meas.	4.7	R	$\sqrt{3}$	1	1	2.7	2.7	∞
Phantom and Tissue Param.								
Phantom Uncertainty	4.0	R	$\sqrt{3}$	1	1	2.3	2.3	∞
Liquid Conductivity (target)	5.0	R.	$\sqrt{3}$	0.64	0.43	1.8	1.2	∞
Liquid Conductivity (meas.)	2.5	N	1	0.64	0.43	1.6	1.1	∞
Liquid Permittivity (target)	5.0	R	$\sqrt{3}$	0.6	0.49	1.7	1.4	∞
Liquid Permittivity (meas.)	2.5	N	1	0.6	0.49	1.5	1.2	∞
Combined Standard Uncertainty						8.4	8.1	∞
Coverage Factor for 95%		kp=2						
Expanded Uncertainty						16.8	16.2	

Dasy4 Uncertainty Budget

7. Phantom description

Schmid & Partner Engineering AG

Zeughausstrasse 43, 8004 Zurich, Switzerland, Phone +41 1 245 97 00, Fax +41 1 245 97 79

Certificate of conformity / First Article Inspection

Item	SAM Twin Phantom V4.0
Type No	QD 000 P40 CA
Series No	TP-1150 and higher
Manufacturer / Origin	Unterssee Composites Hauptstr. 69 CH-8559 Fruttwilen Switzerland

Tests

The series production process used allows the limitation to test of first articles. Complete tests were made on the pre-series Type No. QD 000 P40 AA, Serial No. TP-1001 and on the series first article Type No. QD 000 P40 BA, Serial No. TP-1006. Certain parameters have been retested using further series units (called samples).

Test	Requirement	Details	Units tested
Shape	Compliance with the geometry according to the CAD model.	ITIS CAD File (*)	First article, Samples
Material thickness	Compliant with the requirements according to the standards	2mm +/- 0.2mm in specific areas	First article, Samples
Material parameters	Dielectric parameters for required frequencies	200 MHz - 3 GHz Relative permittivity < 5 Loss tangent < 0.05	Material sample TP-104-5
Material resistivity	The material has been tested to be compatible with the liquids defined in the standards	Liquid type HSL 1800 and others according to the standard.	Pre-series, First article

Standards

- [1] CENELEC EN 50361
- [2] IEEE P1528-200x draft 6.5
- [3] IEC PT 62209 draft 0.9
- (*) The ITIS CAD file is derived from [2] and is also within the tolerance requirements of the shapes of [1] and [3].

Conformity

Based on the sample tests above, we certify that this item is in compliance with the uncertainty requirements of SAR measurements specified in standard [1] and draft standards [2] and [3].

Date 28.02.2002

Signature / Stamp

F. Benschelt

**Schmid & Partner
Engineering AG**

Zeughausstrasse 43, CH-8004 Zurich
Tel. +41 1 245 97 00, Fax +41 1 245 97 79

Thomas Kappeler

8. System validation from original equipment supplier**DASY4 Validation Report for Head TSL**

Date/Time: 19.08.2005 14:48:37

Test Laboratory: SPEAG, Zurich, Switzerland

DUT: Dipole 900 MHz; Type: D900V2; Serial: D900V2 - SN:184

Communication System: CW-900; Frequency: 900 MHz; Duty Cycle: 1:1

Medium: HSL 900 MHz;

Medium parameters used: $f = 900$ MHz; $\sigma = 0.96$ mho/m; $\epsilon_r = 42.1$; $\rho = 1000$ kg/m³

Phantom section: Flat Section

Measurement Standard: DASY4 (High Precision Assessment)

DASY4 Configuration:

- Probe: ET3DV6 - SN1507; CoaxF(5.95, 5.95, 5.95); Calibrated: 26.10.2004
- Sensor-Surface: 4mm (Mechanical Surface Detection)
- Electronics: DAE4 Set601; Calibrated: 07.01.2005
- Phantom: Flat Phantom 4.9L; Type: QD000P49AA
- Measurement SW: DASY4, V4.6 Build 9; Postprocessing SW: SEMCAD, V1.8 Build 151

Pin = 250 mW; d = 15 mm/Area Scan (81x81x1):Measurement grid: $dx=15$ mm, $dy=15$ mm

Maximum value of SAR (interpolated) = 2.81 mW/g

Pin = 250 mW; d = 15 mm/Zoom Scan 2 (7x7x7)/Cube 0:Measurement grid: $dx=5$ mm, $dy=5$ mm, $dz=5$ mm

Reference Value = 56.9 V/m; Power Drift = -0.018 dB

Peak SAR (extrapolated) = 3.84 W/kg

SAR(1 g) = 2.6 mW/g; SAR(10 g) = 1.67 mW/g

Maximum value of SAR (measured) = 2.82 mW/g

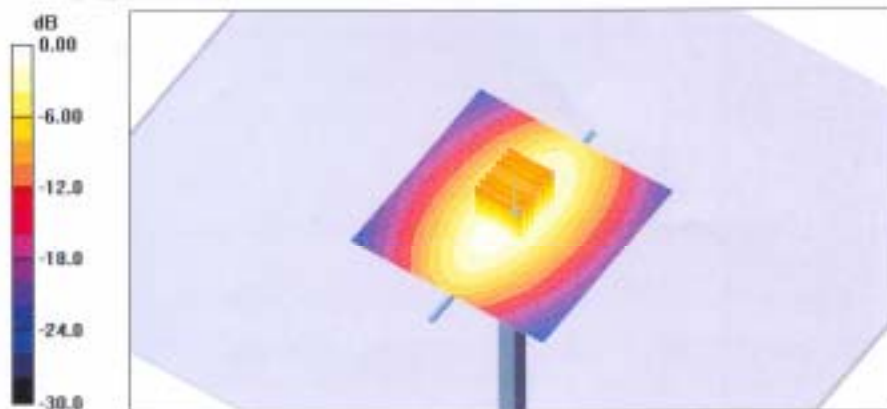

0 dB = 2.82mW/g

DASY4 Validation Report for Body TSL

Date/Time: 22.08.2005 16:14:01

Test Laboratory: SPEAG, Zurich, Switzerland

DUT: Dipole 900 MHz; Type: D900V2; Serial: D900V2 - SN:184

Communication System: CW-900; Frequency: 900 MHz; Duty Cycle: 1:1

Medium: MSL 900 MHz;

Medium parameters used: $f = 900$ MHz; $\sigma = 1.07$ mho/m; $\epsilon_r = 54.6$; $\rho = 1000$ kg/m³

Phantom section: Flat Section

Measurement Standard: DASY4 (High Precision Assessment)

DASY4 Configuration:

- Probe: ET3DVA8 - SN1307; Const(5.77, 5.77, 5.77); Calibrated: 26.10.2004
- Sensor-Surface: 4mm (Mechanical Surface Detection)
- Electronics: DA64 S0601; Calibrated: 07.01.2005
- Phantom: Flat Phantom 4.9L; Type: QD00P49AA
- Measurement SW: DASY4, V4.6 Build 9; Postprocessing SW: SEMCAD, V1.8 Build 151

Pin = 250 mW; d = 15 mm 2/Area Scan (81x81x1):

Measurement grid: dx=15mm, dy=15mm

Maximum value of SAR (interpolated) = 2.94 mW/g

Pin = 250 mW; d = 15 mm 2/Zoom Scan (7x7x7)/Cube 0:

Measurement grid: dx=5mm, dy=5mm, dz=5mm

Reference Value = 55.3 V/m; Power Drift = -0.00 dB

Peak SAR (extrapolated) = 3.90 W/kg

SAR(1 g) = 2.69 mW/g; SAR(10 g) = 1.74 mW/g

Maximum value of SAR (measured) = 2.96 mW/g

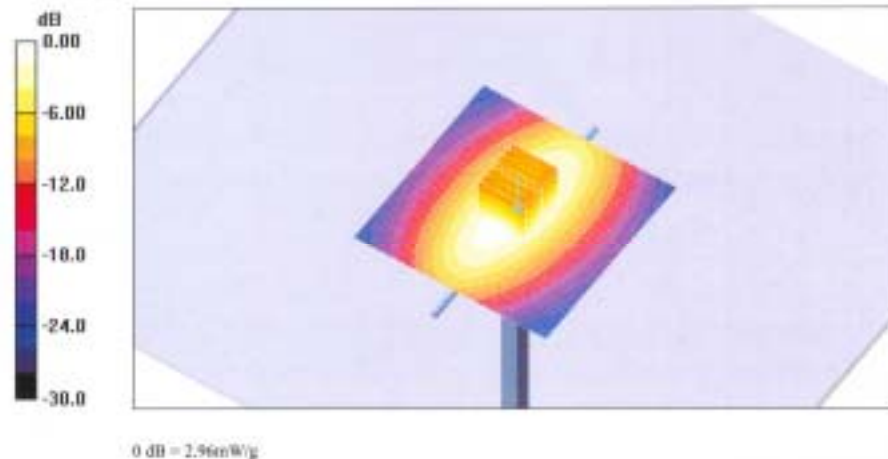

DASY4 Validation Report for Head TSL

Date/Time: 25.08.2005 17:04:02

Test Laboratory: SPEAG, Zurich, Switzerland

DUT: Dipole 1900 MHz; Type: D1900V2; Serial: D1900V2 - SN:5d028

Communication System: CW-1900; Frequency: 1900 MHz; Duty Cycle: 1:1

Medium: HSL 1900 MHz;

Medium parameters used: $f = 1900$ MHz; $\sigma = 1.47$ mho/m; $\epsilon_r = 38.6$; $\rho = 1000$ kg/m³

Phantom section: Flat Section

Measurement Standard: DASY4 (High Precision Assessment)

DASY4 Configuration:

- Probe: ET3DV6 - SN1507; CorvF(4.96, 4.96, 4.96); Calibrated: 26.10.2004
- Sensor-Surface: 4mm (Mechanical Surface Detection)
- Electronics: DAE4 Sn001; Calibrated: 07.01.2005
- Phantom: Flat Phantom 5.0 (front); Type: QD000P50AA
- Measurement SW: DASY4, V4.6 Build 9; Postprocessing SW: SEMCAD, V1.8 Build 151

Pin = 250 mW; d = 10 mm/Area Scan (61x81x1):

Measurement grid: dx=15mm, dy=15mm

Maximum value of SAR (interpolated) = 11.8 mW/g

Pin = 250 mW; d = 10 mm/Zoom Scan (7x7x7)/Cube 0:

Measurement grid: dx=5mm, dy=5mm, dz=5mm

Reference Value = 91.5 V/m; Power Drift = 0.00 dB

Peak SAR (extrapolated) = 17.2 W/kg

SAR(1 g) = 9.89 mW/g; SAR(10 g) = 5.16 mW/g

Maximum value of SAR (measured) = 11.2 mW/g

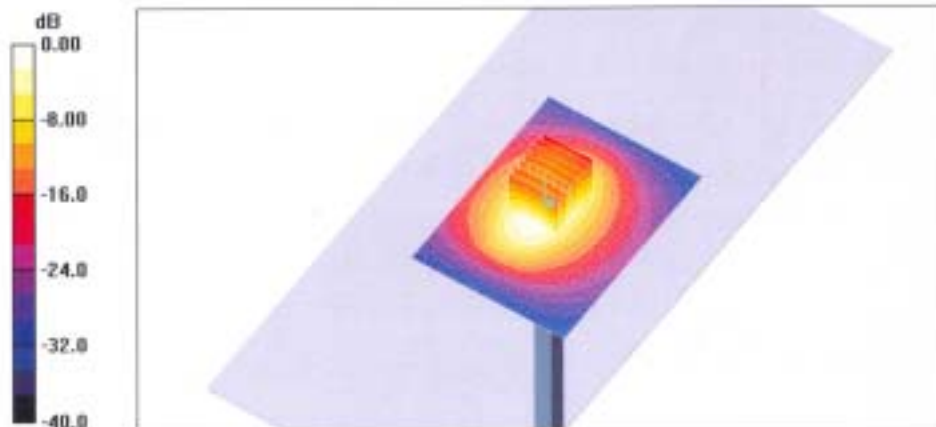

0 dB = 11.2mW/g

DASY4 Validation Report for Body TSL

Date/Time: 26.08.2005 15:32:29

Test Laboratory: SPEAG, Zurich, Switzerland

DUT: Dipole 1900 MHz; Type: D1900V2; Serial: D1900V2 - SN:5d028

Communication System: CW-1900; Frequency: 1900 MHz; Duty Cycle: 1:1

Medium: MSL 1900 MHz;

Medium parameters used: $f = 1900$ MHz; $\sigma = 1.6$ mho/m; $\epsilon_r = 53.3$; $\rho = 1000$ kg/m³

Phantom section: Flat Section

Measurement Standard: DASY4 (High Precision Assessment)

DASY4 Configuration:

- Probe: ET3DV6 - SN1507; ConvP(4.43, 4.43, 4.43); Calibrated: 26.10.2004
- Sensor-Surface: 4mm (Mechanical Surface Detection)
- Electronics: DAE4 Sn601; Calibrated: 07.01.2005
- Phantom: Flat Phantom 5.0 (front); Type: QD000P50AA
- Measurement SW: DASY4, V4.6 Build 9; Postprocessing SW: SEMCAD, V1.8 Build 151

Pin = 250 mW; d = 10 mm 2/Area Scan (81x81x1):

Measurement grid: dx=15mm, dy=15mm

Maximum value of SAR (interpolated) = 11.2 mW/g

Pin = 250 mW; d = 10 mm 2/Zoom Scan (7x7x7)/Cube 0:

Measurement grid: dx=5mm, dy=5mm, dz=5mm

Reference Value = 86.7 V/m; Power Drift = -0.025 dB

Peak SAR (extrapolated) = 16.4 W/kg

SAR(1 g) = 9.81 mW/g; SAR(10 g) = 5.22 mW/g

Maximum value of SAR (measured) = 11.2 mW/g

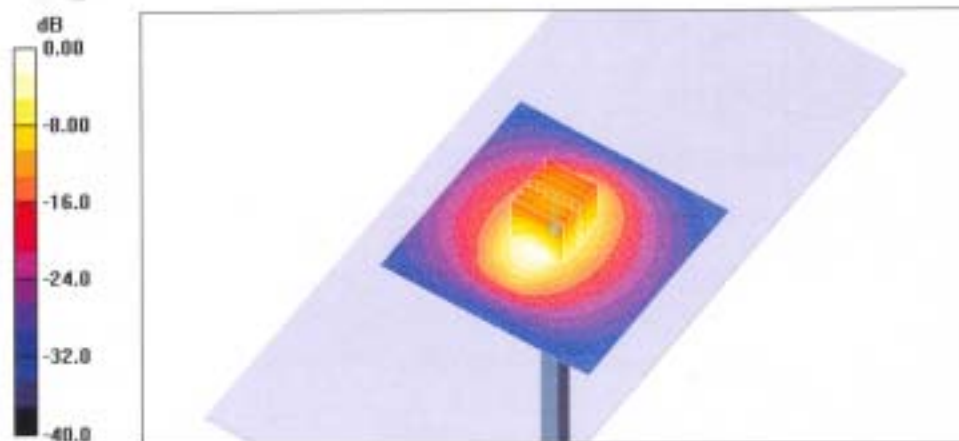

0 dB = 11.2mW/g

The end