

SAR TEST REPORT

Equipment Under Test :	GSM 850&PCS1900MHz MOBILE PHONE
Model No. :	D6Ca
Market name:	OT-C630a
FCC ID :	RAD033
Applicant :	T&A Mobile phones
Address of Applicant :	4/F, No.2966, Jinke Rd, Zhangjiang High-Tech Park, Pudong Shanghai 201203. P. R. China
Date of Receipt :	2006.07.03
Date of Test :	2006.07.06 – 2006.07.13
Date of Issue :	2006.07.20

Standards:

**FCC OET Bulletin 65 supplement C,
ANSI/IEEE C95.1, C95.3, IEEE 1528-2003**

In the configuration tested, the EUT complied with the standards specified above.

Remarks:

This report details the results of the testing carried out on one sample, the results contained in this test report do not relate to other samples of the same product. The manufacturer should ensure that all products in series production are in conformity with the product sample detailed in this report.

This report may only be reproduced and distributed in full. If the product in this report is used in any configuration other than that detailed in the report, the manufacturer must ensure the new system complies with all relevant standards. Any mention of SGS-CSTC Shanghai GSM Lab or testing done by SGS-CSTC Shanghai GSM Lab must approve SGS Shanghai GSM Lab in connection with distribution or use of the product described in this report in writing.

Tested by :

Roger Ruan

Date :

2006.07.20

Approved by :

Zhang Yuan

Date :

2006.07.20

Contents

1. General Information	5
1.1 Test Laboratory	5
1.2 Details of Applicant.....	5
1.3 Description of EUT(s)	5
1.4 Test Environment	6
1.5 Operation Configuration.....	6
1.6 The SAR Measurement System	6
1.7 SAR System Verification	8
1.8 Tissue Simulant Fluid for the Frequency Band 850MHz and 1900MHZ.....	9
1.9 Test Standards and Limits	10
2. Summary of Results.....	11
3. Instruments List	14
4. Measurements	15
4.1LeftHandSide-Cheek-GSM850-Low	15
FCC-OET65-LeftHandSide-Cheek-GSM850-Low	15
4.2LeftHandSide-Cheek-GSM850-Middle	16
FCC-OET65-LeftHandSide-Cheek-GSM850-Mid.....	16
4.3LeftHandSide-Cheek-GSM850-High.....	17
FCC-OET65-LeftHandSide-Cheek-GSM850-High	18
4.4LeftHandSide-Tilt-GSM850-Low	19
FCC-OET65-LeftHandSide-Tilt-GSM850-Low	19
4.5LeftHandSide-Tilt-GSM850-Middle.....	21
FCC-OET65-LeftHandSide-Tilt-GSM850-Mid	21
4.6LeftHandSide-Tilt-GSM850-High	22
FCC-OET65-LeftHandSide-Tilt-GSM850-High.....	22
4.7RightHandSide-Cheek-GSM850-Low	24
FCC-OET65-RightHandSide-Cheek-GSM850-Low.....	24
4.8RightHandSide-Cheek-GSM850-Middle.....	26
FCC-OET65-RightHandSide-Cheek-GSM850-Mid	26
4.9RightHandSide-Cheek-GSM850-High	27
FCC-OET65-RightHandSide-Cheek-GSM850-High	27
4.10RightHandSide-Tilt-GSM850-Low	28
FCC-OET65-RightHandSide-Tilt-GSM850-Low	29

4.11RightHandSide-Tilt-GSM850-Middle	30
FCC-OET65-RightHandSide-Tilt-GSM850-Mid.....	30
RightHandSide-Tilt-GSM850-High	Error! Bookmark not defined.
FCC-OET65-RightHandSide-Tilt-GSM850-High.....	31
4.13Body-Worn-GSM850-GPRS-Low	33
FCC-OET65-Body-Worn-GSM850-GPRS-Low-2cm.....	33
4.14Body-Worn-GSM850-GPRS-Middle.....	34
FCC-OET65-Body-Worn-GSM850-GPRS-Mid-2cm	35
4.15Body-Worn-GSM850-GPRS-High	36
FCC-OET65-Body-Worn-GSM850-GPRS-High-2cm.....	36
4.16LeftHandSide-Cheek-PCS1900-Low	37
FCC-OET65-LeftHandSide-Cheek-PCS1900-Low	38
4.17LeftHandSide-Cheek-PCS1900-Middle	39
FCC-OET65-LeftHandSide-Cheek-PCS1900-Mid	39
4.18LeftHandSide-Cheek-PCS1900-High.....	41
FCC-OET65-LeftHandSide-Cheek-PCS1900-High.....	41
4.19LeftHandSide-Tilt-PCS1900-Low	43
FCC-OET65-LeftHandSide-Tilt-PCS1900-Low	43
4.20LeftHandSide-Tilt-PCS1900-Middle.....	45
FCC-OET65-LeftHandSide-Tilt-PCS1900-Mid.....	45
4.21LeftHandSide-Tilt-PCS1900-High	47
FCC-OET65-LeftHandSide-Tilt-PCS1900-High	47
4.22RightHandSide-Cheek-PCS1900-Low.....	49
FCC-OET65-RightHandSide-Cheek-PCS1900-Low	49
4.23RightHandSide-Cheek-PCS1900-Middle	51
FCC-OET65-RightHandSide-Cheek-PCS1900-Mid.....	51
4.24RightHandSide-Cheek-PCS1900-High.....	52
FCC-OET65-RightHandSide-Cheek-PCS1900-High.....	52
4.25RightHandSide-Tilt-PCS1900-Low	53
FCC-OET65-RightHandSide-Tilt-PCS1900-Low	54
4.26RightHandSide-Tilt-PCS1900-Middle	55
FCC-OET65-RightHandSide-Tilt-PCS1900-Mid	55
4.27RightHandSide-Tilt-PCS1900-High	56
FCC-OET65-RightHandSide-Tilt-PCS1900-High	56
4.28Body-Worn-PCS1900-GPRS-Low.....	58

FCC-OET65-Body-Worn-PCS1900-GPRS-Low-2cm	58
4.29 Body-Worn-PCS1900-GPRS-Middle	60
FCC-OET65-Body-Worn-PCS1900-GPRS-Mid-2cm	60
4.30 Body-Worn-PCS1900-GPRS-High	61
FCC-OET65-Body-Worn-PCS1900-GPRS-High-2cm	61
Appendix	64
1. Photographs of Test Setup	64
2. Photographs of the EUT	67
3. Photographs of the battery	68
4. Photograph of the charger	69
5. Probe Calibration certificate	70
6. Uncertainty analysis	79
7. Phantom description	80
8. System validation from original equipment supplier	81

1. General Information

1.1 Test Laboratory

GSM Lab
 SGS-CSTC Standards Technical Services Co.Ltd Shanghai Branch
 9F, the 3rd Building, No.889, Yishan Rd, Xuhui District, Shanghai, China
 Zip code: 200233
 Telephone: +86 (0) 21 6495 1616
 Fax: +86 (0) 21 5450 0149
 Internet: <http://www.cn.sgs.com>

1.2 Details of Applicant

Name: T&A Mobile phones
 Address: 4/F, No.2966, Jinke Rd, Zhangjiang High-Tech Park,
 Pudong Shanghai 201203. P. R. China

1.3 Description of EUT(s)

Brand name	ALCATEL	
Model No.	D6Ca	
Market Name	OT-C630a	
Serial No.	IMEI: 01090000000322-7	
Sample Status	Production	
Battery Type	Lithium-Ion	
Antenna Type	Inner Antenna	
Operation Mode	GSM850/PCS1900	
Modulation Mode	GMSK	
Frequency range	GSM850	Tx: 824~849 MHz
		Rx: 869~894 MHz
	PCS1900	Tx: 1850~1910 MHz
		Rx: 1930~1990 MHz
Maximum RF Conducted Power	GSM850: 33dBm, PCS1900: 30dBm	
GPRS	Multi-Slot Class 10 uplink 2TS	

1.4 Test Environment

Ambient temperature: 22.0° C

Tissue Simulating Liquid: 22° C

Relative Humidity: 45%~55%

1.5 Operation Configuration

Configuration 1: GSM 850, LeftHandSide Cheek & 15 ° Tilt Position

Configuration 2: GSM 850, RightHandSide Cheek & 15 ° Tilt Position

Configuration 3: GSM 850, GPRS,BodyWorn (2.0 cm between EUT and phantom)

Configuration 4: PCS 1900, LeftHandSide Cheek & 15 ° Tilt Position

Configuration 5: PCS 1900, RightHandSide Cheek & 15 ° Tilt Position

Configuration 6: PCS 1900, GPRS,BodyWorn (2.0 cm between EUT and phantom)

1.6 The SAR Measurement System

A photograph of the SAR measurement System is given in Fig. a.

This SAR Measurement System uses a Computer-controlled 3-D stepper motor system (Speag Dasy 4 professional system). A Model ES3DV3 3088 E-field probe is used to determine the internal electric fields. The SAR can be obtained from the equation $SAR = \sigma (|E_i|^2) / \rho$ where σ and ρ are the conductivity and mass density of the tissue-simulant.

The DASY4 system for performing compliance tests consists of the following items:

- A standard high precision 6-axis robot (Stabile RX family) with controller, teach pendant and software. An arm extension for accommodation the data acquisition electronics (DAE).
- A dosimetric probe, i.e., an isotropic E-field probe optimized and calibrated for usage in tissue simulating liquid. The probe is equipped with an optical surface detector system.
- A data acquisition electronics (DAE) which performs the signal amplification, signal multiplexing, AD-conversion, offset measurements, mechanical surface detection, collision detection, etc. The unit is battery powered with standard or rechargeable batteries. The signal is optically transmitted to the EOC.

- The Electro-optical converter (EOC) performs the conversion between optical and electrical of the signals for the digital communication to DAE and for the analog signal from the optical surface detection. The EOC is connected to the measurement server.

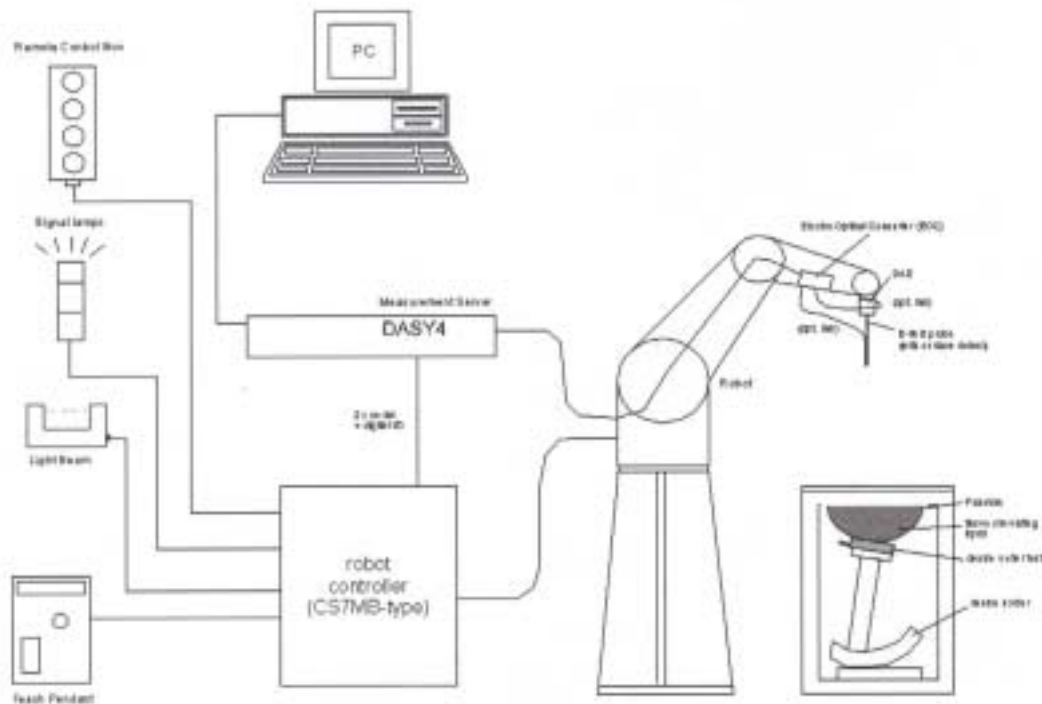

Fig. a SAR System Configuration

- The function of the measurement server is to perform the time critical tasks such as signal filtering, control of the robot operation and fast movement interrupts.
- A probe alignment unit which improves the (absolute) accuracy of the probe positioning.
- A computer operating Windows 2000.
- DASY4 software.
- Remote control with teach pendant and additional circuitry for robot safety such as warning lamps, etc.
- The SAM twin phantom enabling testing left-hand, right-hand and body-worn usage.
- The device holder for handheld mobile phones.
- Tissue simulating liquid mixed according to the given recipes.

- Validation dipole kits allowing to validating the proper functioning of the system.

1.7 SAR System Verification

The microwave circuit arrangement for system verification is sketched in Fig. b. The daily system accuracy verification occurs within the flat section of the SAM phantom. A SAR measurement was performed to see if the measured SAR was within +/- 10% from the target SAR values. These tests were done at 900MHz and 1900MHz. The tests were conducted on the same days as the measurement of the DUT. The obtained results from the system accuracy verification are displayed in the table 1 (SAR values are normalized to 1W forward power delivered to the dipole). During the tests, the ambient temperature of the laboratory was in the range 22°C, the relative humidity was in the range 60% and the liquid depth above the ear reference points was above 15 cm in all the cases. It is seen that the system is operating within its specification, as the results are within acceptable tolerance of the reference values.

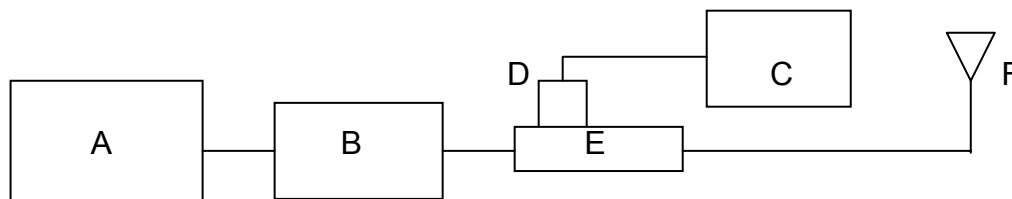

Fig. b the microwave circuit arrangement used for SAR system verification

- A. Agilent Model E4438C Signal Generator
- B. Mini-Circuit Model ZHL-42 Preamplifier
- C. Agilent Model E4416A Power Meter
- D. Agilent Model 8481H Power Sensor
- E. HT CP6100 20N Dual directional coupler
- F. Reference dipole antenna

Validation Kit	Frequency MHz	Target SAR 1g (250mW)	Target SAR 10g (250mW)	Measured SAR 1g	Measured SAR 10g	Measured Date
ES3DV3 SN3088	900 Head	2.6	1.67	2.63	1.65	2006-07-06
ES3DV3 SN3088	900 Body	2.69	1.74	2.67	1.71	2006-07-06
ES3DV3 SN3088	1900 Head	9.89	5.16	9.72	5.11	2006-07-10
ES3DV3 SN3088	1900 Body	9.81	5.22	9.69	5.17	2006-07-13

Table 1. Result System Validation

1.8 Tissue Simulant Fluid for the Frequency Band 850MHz and 1900MHz

The dielectric properties for this body-simulant fluid were measured by using the HP Model 85070D Dielectric Probe (rates frequency band 200 MHz to 20 GHz) in conjunction with Agilent E5071B Network Analyzer (300 KHz-8500 MHz). The Conductivity (σ) and Permittivity (ρ) are listed in Table 2. For the SAR measurement given in this report. The temperature variation of the Tissue Simulant Fluid was 22°C.

Frequency (MHz)	Tissue Type	Limit/Measured	Permittivity (ρ)	Conductivity (σ)	Simulated Tissue Temp (°C)
900	Head	Measured, 2006-07-06	42.06	0.939	22.5
		Recommended Limit	41.5±5%	0.97±5%	20-24
	Body	Measured, 2006-07-06	52.44	1.007	22.5
		Recommended Limit	55.0±5%	1.05±5%	20-24
1900	Head	Measured, 2006-07-10	39.83	1.463	22.3
		Recommended Limit	40.0±5%	1.40±5%	20-24
	Body	Measured, 2006-07-13	51.45	1.564	22.6
		Recommended Limit	53.3±5%	1.52±5%	20-24

Table 2. Dielectric parameters for the Frequency Band 900MHz&1900MHz

1.9 Test Standards and Limits

According to FCC 47 CFR §2.1093(d) the limits to be used for evaluation are based generally on criteria published by the American National Standards Institute (ANSI) for localized specific absorption rate (SAR) in Section 4.2 of "IEEE Standard for Safety Levels with Respect to Human Exposure to Radio Frequency Electromagnetic Fields, 3KHz to 300GHz," ANSI/IEEE C95.1-1992, Copyright 1992 by the Institute of Electrical & Electronics Engineers, Inc., New York, New York 10071.

Human Exposure	Uncontrolled Environment General Population
Spatial Peak SAR (Brain)	1.60 mW/g (averaged over a mass of 1g)

Table 3. RF Exposure Limits

Notes:

1. Uncontrolled environments are defined as locations where there is potential exposure of individuals who have no knowledge or control of their potential exposure.

2. Summary of Results

Frequency Band(MHz)	EUT position	Conducted Output Power (dBm)	1g Avg. (mW/g)	10g Avg. (mW/g)	Power Drift (dB)	Amb. Temp ()	Verdict
GSM 850	LeftHandSide Cheek, Low Channel	32.4	0.506	0.341	0.040	22	PASS
	LeftHandSide Cheek, Mid Channel	32.3	0.734	0.493	-0.043	22	PASS
	LeftHandSide Cheek, High Channel	32.2	1.06	0.713	-0.101	22	PASS
	LeftHandSide Tilt, Low Channel	32.4	0.252	0.177	-0.006	22	PASS
	LeftHandSide Tilt, Mid Channel	32.3	0.366	0.256	-0.037	22	PASS
	LeftHandSide Tilt, High Channel	32.2	0.535	0.373	-0.402	22	PASS
	RightHandSide Cheek, Low Channel	32.4	0.600	0.403	-0.040	22	PASS
	RightHandSide Cheek, Mid Channel	32.3	0.896	0.597	0.081	22	PASS
	RightHandSide Cheek, High Channel	32.2	1.17	0.779	-0.406	22	PASS
	RightHandSide Tilt, Low Channel	32.4	0.181	0.129	-0.028	22	PASS
	RightHandSide Tilt, Mid Channel	32.3	0.265	0.188	-0.005	22	PASS
	RightHandSide Tilt, High Channel	32.2	0.414	0.292	-0.039	22	PASS
GSM 850	GPRS,BodyWorn, Low Channel	32.4	0.167	0.108	-0.020	22	PASS
	GPRS,BodyWorn, Mid Channel	32.3	0.285	0.184	0.054	22	PASS
	GPRS,BodyWorn, High Channel	32.2	0.480	0.306	-0.292	22	PASS
PCS 1900	LeftHandSide Cheek, Low Channel	28.8	0.307	0.187	-0.375	22	PASS
	LeftHandSide Cheek, Mid Channel	28.7	0.330	0.198	-0.264	22	PASS
	LeftHandSide Cheek, High Channel	28.7	0.273	0.162	0.004	22	PASS
	LeftHandSide Tilt, Low Channel	28.8	0.064	0.038	-0.208	22	PASS
	LeftHandSide Tilt, Mid Channel	28.7	0.051	0.029	-0.148	22	PASS
	LeftHandSide Tilt, High Channel	28.7	0.039	0.022	0.049	22	PASS

	RightHandSide Cheek, Low Channel	28.8	0.345	0.208	-0.415	22	PASS
	RightHandSide Cheek, Mid Channel	28.7	0.365	0.217	-0.310	22	PASS
	RightHandSide Cheek, High Channel	28.7	0.331	0.195	-0.148	22	PASS
	RightHandSide Tilt, Low Channel	28.8	0.072	0.041	-0.097	22	PASS
	RightHandSide Tilt, Mid Channel	28.7	0.064	0.036	-0.054	22	PASS
	RightHandSide Tilt, High Channel	28.7	0.051	0.028	-0.063	22	PASS
PCS 1900	GPRS,BodyWorn, Low Channel	28.8	0.721	0.438	-0.176	22	PASS
	GPRS,BodyWorn, Mid Channel	28.7	0.654	0.394	-0.143	22	PASS
	GPRS,BodyWorn, High Channel	28.7	0.532	0.319	-0.008	22	PASS

Maximum Values

Frequency Band(MHz)	EUT position	Conducted Output Power (dBm)	1g Average (W/Kg)	10g Average (W/Kg)	Power Drift (dB)	Amb. Temp ()	Verdict
GSM850	LeftHandSide Cheek, High Channel	32.2	1.06	0.713	-0.101	22	PASS
	RightHandSide Cheek, High Channel	32.2	1.17	0.779	-0.406	22	PASS
	GPRS,BodyWorn, High Channel	32.2	0.480	0.306	-0.292	22	PASS
PCS1900	LeftHandSide Cheek, Mid Channel	28.7	0.330	0.198	-0.264	22	PASS
	RightHandSide Cheek, Mid Channel	28.7	0.365	0.217	-0.310	22	PASS
	GPRS,BodyWorn, Low Channel	28.8	0.721	0.438	-0.176	22	PASS

Note:

1. In GSM850 band, the low, middle and high channels are CH128/824.2MHz, CH189/836.4MHz and CH251/848.8MHz separately.
2. In PCS1900 band, the low, middle and high channels are CH512/1805.2MHz, CH661/1880.0MHz and CH810/1909.8MHz separately.
3. For the Bodyworn measurements the sample was only placed with the antenna toward the phantom since this position delivers the highest SAR values.
4. For the Bodyworn measurements, the distance from the sample to the phantom is 2.0 cm.

5. The antenna is located at the bottom of the Mobile Station. For details see Figure 12 in appendix

3. Instruments List

Instrument	Model	Serial number	NO.	Date of last Calibration
Desktop PC	COMPAQ EVO	N/A	GSM-SAR-025	N/A
Dasy 4 software	V 4.6 build 23	N/A	GSM-SAR-001	N/A
Probe	ES3DV3	3088	GSM-SAR-034	2005.09.13
DAE	DAE3	569	GSM-SAR-023	2005.11.17
Phantom	SAM 12	TP-1283	GSM-SAR-005	N/A
Robot	RX90L	F03/5V32A1/A01	GSM-SAR-008	N/A
900MHz system validation dipole	D900V2	184	GSM-SAR-013	2005.8.22
1900MHz system validation dipole	D1900V2	5d028	GSM-SAR-020	2005.8.25
Dielectric probe kit	85070D	US01440168	GSM-SAR-016	2005.12.19
Agilent network analyzer	E5071B	MY42100549	GSM-SAR-007	2005.12.19
Agilent signal generator	E4438	14438CATO-19719	GSM-SAR-008	2005.12.19
Mini-Circuits preamplifier	ZHL-42	D041905	GSM-SAR-035	2006.04.19
Agilent power meter	E4416A	GB41292095	GSM-SAR-010	2005.12.19
Agilent power sensor	8481H	MY41091234	GSM-SAR-011	2005.12.19
HT CP6100 20N Coupling	6100	SCP301480120	GSM-SAR-012	2005.12.19
R&S Universal radio communication tester	CMU200	103633	GSM-AUD-002	2005.12.20

4. Measurements

4.1 LeftHandSide-Cheek-GSM850-Low

Date/Time: 2006-7-10 9:28:48

Test Laboratory: SGS-GSM

FCC-OET65-LeftHandSide-Cheek-GSM850-Low

DUT: GSM10006703M-Head; Type: Head; Serial: 01090000000322-7

Communication System: GSM850-GSM Mode; Frequency: 824.2 MHz; Duty Cycle: 1:8.3

Medium: HSL850-Head Medium parameters used: $f = 824.2$ MHz; $\epsilon = 0.882$ mho/m; $\mu_r = 42.4$; $\rho = 1000$ kg/m³

Phantom section: Left Section

Measurement Standard: DAS4 (High Precision Assessment)

DAS4 Configuration:

- Probe: ES3DV3 - SN3088; ConvF(5.91, 5.91, 5.91); Calibrated: 2005-9-13
- Sensor-Surface: 4mm (Mechanical Surface Detection)
- Electronics: DAE3 Sn569; Calibrated: 2005-11-17
- Phantom: SAM 12; Type: SAM V4.0; Serial: TP-1283
- Measurement SW: DAS4, V4.6 Build 23; Postprocessing SW: SEMCAD, V1.8 Build 160

Cheek position - Low/Area Scan (61x101x1): Measurement grid: dx=15mm, dy=15mm

Maximum value of SAR (interpolated) = 0.547 mW/g

Cheek position - Low/Zoom Scan (7x7x7)/Cube 0: Measurement grid: dx=5mm, dy=5mm, dz=5mm

Reference Value = 8.98 V/m; Power Drift = 0.040 dB

Peak SAR (extrapolated) = 0.703 W/kg

SAR(1 g) = 0.506 mW/g; SAR(10 g) = 0.341 mW/g

Maximum value of SAR (measured) = 0.546 mW/g

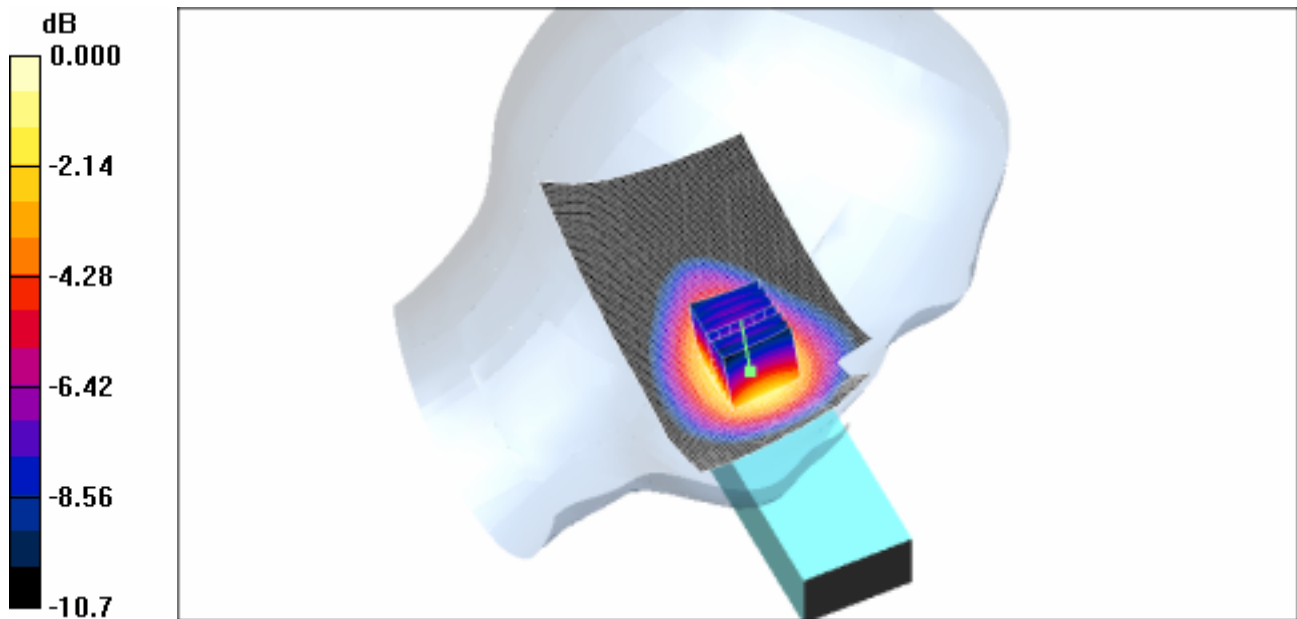

0 dB = 0.546mW/g

4.2 LeftHandSide-Cheek-GSM850-Middle

Date/Time: 2006-7-10 10:27:33

Test Laboratory: SGS-GSM

FCC-OET65-LeftHandSide-Cheek-GSM850-Mid

DUT: GSM10006703M-Head; Type: Head; Serial: 01090000000322-7

Communication System: GSM850-GSM Mode; Frequency: 836.4 MHz; Duty Cycle: 1:8.3

Medium: HSL850-Head Medium parameters used: $f = 836.4 \text{ MHz}$; $\sigma = 0.901 \text{ mho/m}$; $\epsilon_r = 42.2$; $\rho = 1000 \text{ kg/m}^3$

Phantom section: Left Section

Measurement Standard: DASY4 (High Precision Assessment)

DASY4 Configuration:

- Probe: ES3DV3 - SN3088; ConvF(5.91, 5.91, 5.91); Calibrated: 2005-9-13
- Sensor-Surface: 4mm (Mechanical Surface Detection)
- Electronics: DAE3 Sn569; Calibrated: 2005-11-17

- Phantom: SAM 12; Type: SAM V4.0; Serial: TP-1283
- Measurement SW: DASY4, V4.6 Build 23; Postprocessing SW: SEMCAD, V1.8 Build 160

Cheek position - Mid/Area Scan (61x101x1): Measurement grid: dx=15mm, dy=15mm

Maximum value of SAR (interpolated) = 0.801 mW/g

Cheek position - Mid/Zoom Scan (7x7x7) (7x7x7)/Cube 0: Measurement grid: dx=5mm, dy=5mm, dz=5mm

Reference Value = 10.8 V/m; Power Drift = -0.043 dB

Peak SAR (extrapolated) = 1.02 W/kg

SAR(1 g) = 0.734 mW/g; SAR(10 g) = 0.493 mW/g

Maximum value of SAR (measured) = 0.782 mW/g

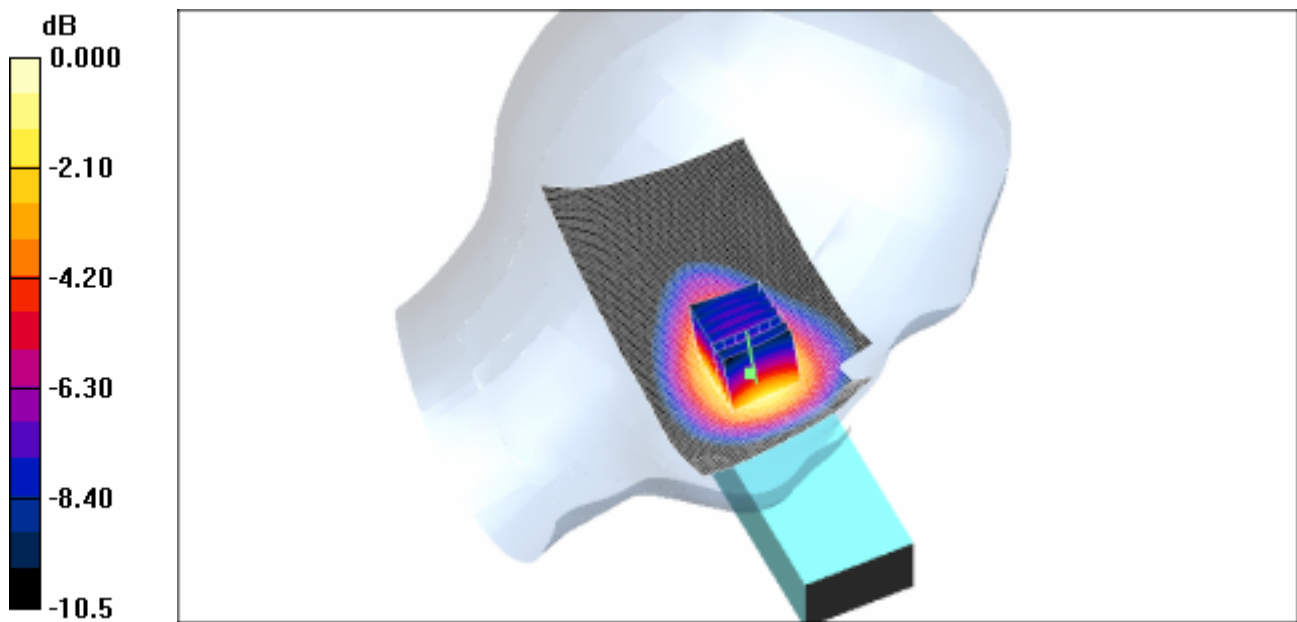

4.3LeftHandSide-Cheek-GSM850-High

Date/Time: 2006-7-10 10:57:04

Test Laboratory: SGS-GSM

FCC-OET65-LeftHandSide-Cheek-GSM850-High

DUT: GSM10006703M-Head; Type: Head; Serial: 01090000000322-7

Communication System: GSM850-GSM Mode; Frequency: 848.8 MHz; Duty Cycle: 1:8.3

Medium: HSL850-Head Medium parameters used: $f = 848.8$ MHz; $\epsilon = 0.921$ mho/m; $\mu_r = 42.2$; $\rho = 1000$ kg/m³

Phantom section: Left Section

Measurement Standard: DASY4 (High Precision Assessment)

DASY4 Configuration:

- Probe: ES3DV3 - SN3088; ConvF(5.91, 5.91, 5.91); Calibrated: 2005-9-13
- Sensor-Surface: 4mm (Mechanical Surface Detection)
- Electronics: DAE3 Sn569; Calibrated: 2005-11-17
- Phantom: SAM 12; Type: SAM V4.0; Serial: TP-1283
- Measurement SW: DASY4, V4.6 Build 23; Postprocessing SW: SEMCAD, V1.8 Build 160

Cheek position - High/Area Scan (61x101x1): Measurement grid: dx=15mm, dy=15mm

Maximum value of SAR (interpolated) = 1.18 mW/g

Cheek position - High/Zoom Scan (7x7x7) (7x7x7)/Cube 0: Measurement grid: dx=5mm, dy=5mm, dz=5mm

Reference Value = 13.0 V/m; Power Drift = -0.101 dB

Peak SAR (extrapolated) = 1.49 W/kg

SAR(1 g) = 1.06 mW/g; SAR(10 g) = 0.713 mW/g

Maximum value of SAR (measured) = 1.13 mW/g

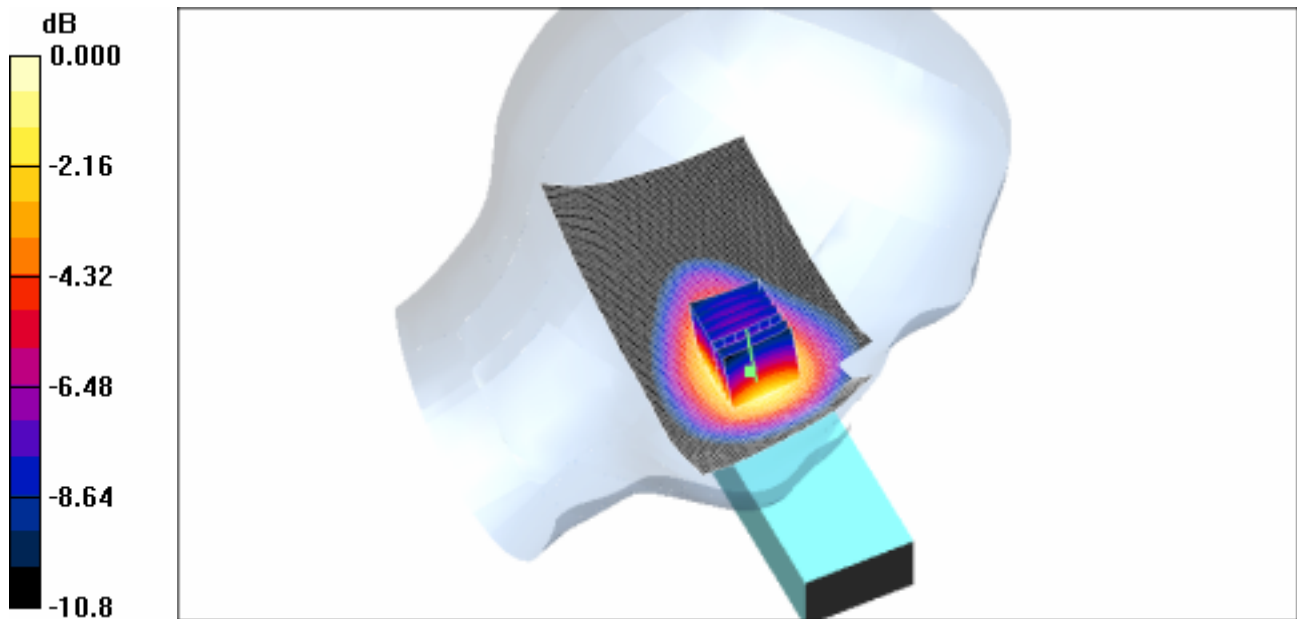

0 dB = 1.13mW/g

4.4 LeftHandSide-Tilt-GSM850-Low

Date/Time: 2006-7-10 12:24:58

Test Laboratory: SGS-GSM

FCC-OET65-LeftHandSide-Tilt-GSM850-Low

DUT: GSM10006703M-Head; Type: Head; Serial: 01090000000322-7

Communication System: GSM850-GSM Mode; Frequency: 824.2 MHz; Duty Cycle: 1:8.3

Medium: HSL850-Head Medium parameters used: $f = 824.2 \text{ MHz}$; $\sigma = 0.882 \text{ mho/m}$; $r = 42.4$; $\rho = 1000 \text{ kg/m}^3$

Phantom section: Left Section

Measurement Standard: DASY4 (High Precision Assessment)

DASY4 Configuration:

- Probe: ES3DV3 - SN3088; ConvF(5.91, 5.91, 5.91); Calibrated: 2005-9-13
- Sensor-Surface: 4mm (Mechanical Surface Detection)
- Electronics: DAE3 Sn569; Calibrated: 2005-11-17

- Phantom: SAM 12; Type: SAM V4.0; Serial: TP-1283
- Measurement SW: DASY4, V4.6 Build 23; Postprocessing SW: SEMCAD, V1.8 Build 160

Tilt position - Low/Area Scan (61x101x1): Measurement grid: dx=15mm, dy=15mm

Maximum value of SAR (interpolated) = 0.272 mW/g

Tilt position - Low/Zoom Scan (7x7x7)/Cube 0: Measurement grid: dx=5mm, dy=5mm, dz=5mm

Reference Value = 13.0 V/m; Power Drift = -0.006 dB

Peak SAR (extrapolated) = 0.334 W/kg

SAR(1 g) = 0.252 mW/g; SAR(10 g) = 0.177 mW/g

Maximum value of SAR (measured) = 0.269 mW/g

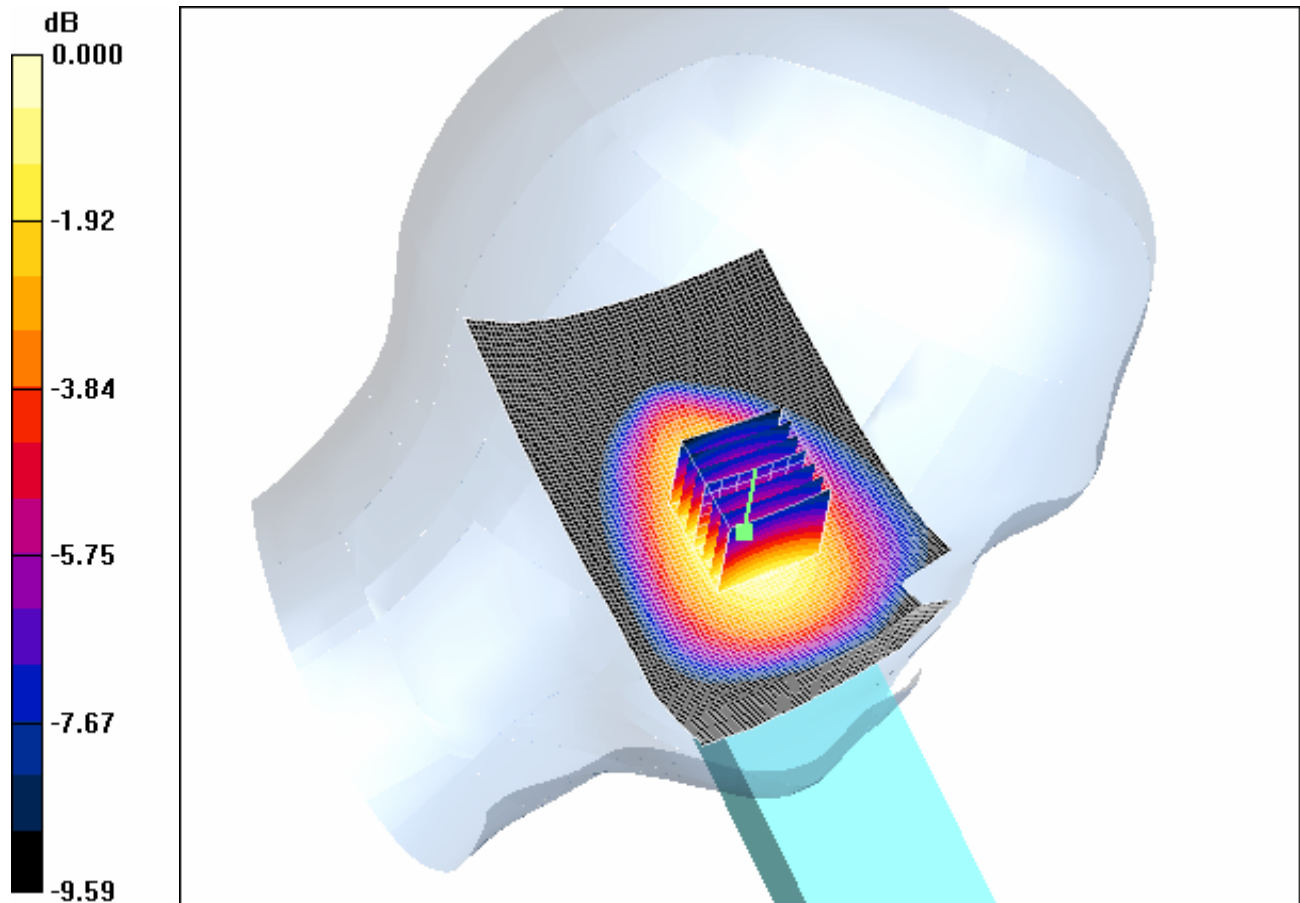

0 dB = 0.269mW/g

4.5LeftHandSide-Tilt-GSM850-Middle

Date/Time: 2006-7-10 12:51:23

Test Laboratory: SGS-GSM

FCC-OET65-LeftHandSide-Tilt-GSM850-Mid

DUT: GSM10006703M-Head; Type: Head; Serial: 01090000000322-7

Communication System: GSM850-GSM Mode; Frequency: 836.4 MHz;Duty Cycle: 1:8.3

Medium: HSL850-Head Medium parameters used: $f = 836.4 \text{ MHz}$; $\epsilon = 0.901 \text{ mho/m}$; $r = 42.2$; $\rho = 1000 \text{ kg/m}^3$

Phantom section: Left Section

Measurement Standard: DAS4 (High Precision Assessment)

DASY4 Configuration:

- Probe: ES3DV3 - SN3088; ConvF(5.91, 5.91, 5.91); Calibrated: 2005-9-13
- Sensor-Surface: 4mm (Mechanical Surface Detection)
- Electronics: DAE3 Sn569; Calibrated: 2005-11-17
- Phantom: SAM 12; Type: SAM V4.0; Serial: TP-1283
- Measurement SW: DAS4, V4.6 Build 23; Postprocessing SW: SEMCAD, V1.8 Build 160

Tilt position - Middle/Area Scan (61x101x1): Measurement grid: $dx=15\text{mm}$, $dy=15\text{mm}$

Maximum value of SAR (interpolated) = 0.394 mW/g

Tilt position - Middle/Zoom Scan (7x7x7) (7x7x7)/Cube 0: Measurement grid: $dx=5\text{mm}$, $dy=5\text{mm}$, $dz=5\text{mm}$

Reference Value = 15.6 V/m; Power Drift = -0.037 dB

Peak SAR (extrapolated) = 0.493 W/kg

SAR(1 g) = 0.366 mW/g; SAR(10 g) = 0.256 mW/g

Maximum value of SAR (measured) = 0.391 mW/g

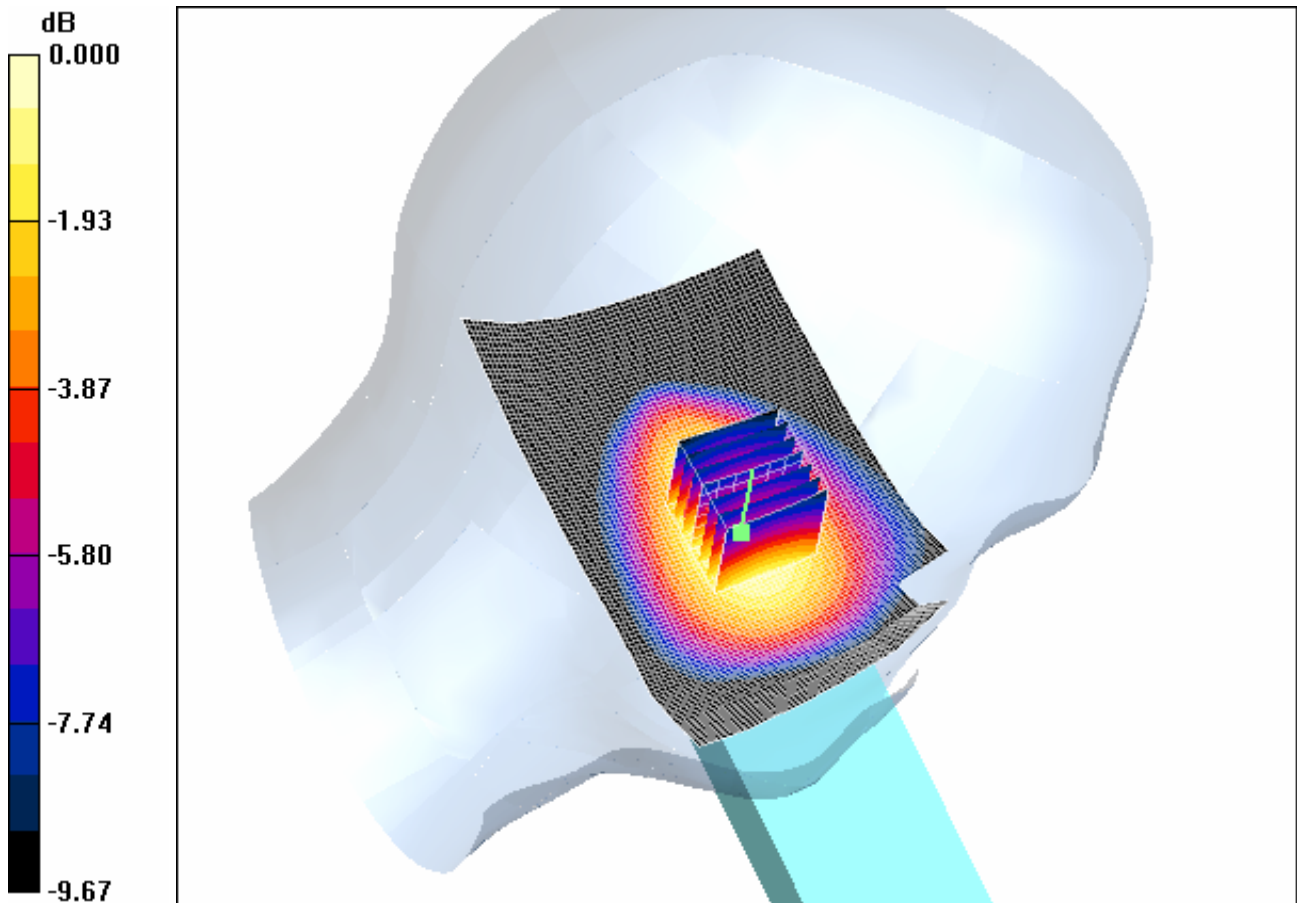

0 dB = 0.391mW/g

4.6 LeftHandSide-Tilt-GSM850-High

Date/Time: 2006-7-10 13:36:09

Test Laboratory: SGS-GSM

FCC-OET65-LeftHandSide-Tilt-GSM850-High

DUT: GSM10006703M-Head; Type: Head; Serial: 01090000000322-7

Communication System: GSM850-GSM Mode; Frequency: 848.8 MHz; Duty Cycle: 1:8.3

Medium: HSL850-Head Medium parameters used: $f = 848.8$ MHz; $\sigma = 0.921$ mho/m; $\epsilon_r = 42.2$; $\rho = 1000$ kg/m³

Phantom section: Left Section

Measurement Standard: DASY4 (High Precision Assessment)

DASY4 Configuration:

- Probe: ES3DV3 - SN3088; ConvF(5.91, 5.91, 5.91); Calibrated: 2005-9-13
- Sensor-Surface: 4mm (Mechanical Surface Detection)
- Electronics: DAE3 Sn569; Calibrated: 2005-11-17
- Phantom: SAM 12; Type: SAM V4.0; Serial: TP-1283
- Measurement SW: DASY4, V4.6 Build 23; Postprocessing SW: SEMCAD, V1.8 Build 160

Tilt position - High/Area Scan (61x101x1): Measurement grid: dx=15mm, dy=15mm

Maximum value of SAR (interpolated) = 0.599 mW/g

Tilt position - High/Zoom Scan (7x7x7) (7x7x7)/Cube 0: Measurement grid: dx=5mm, dy=5mm, dz=5mm

Reference Value = 19.2 V/m; Power Drift = -0.402 dB

Peak SAR (extrapolated) = 0.720 W/kg

SAR(1 g) = 0.535 mW/g; SAR(10 g) = 0.373 mW/g

Maximum value of SAR (measured) = 0.568 mW/g

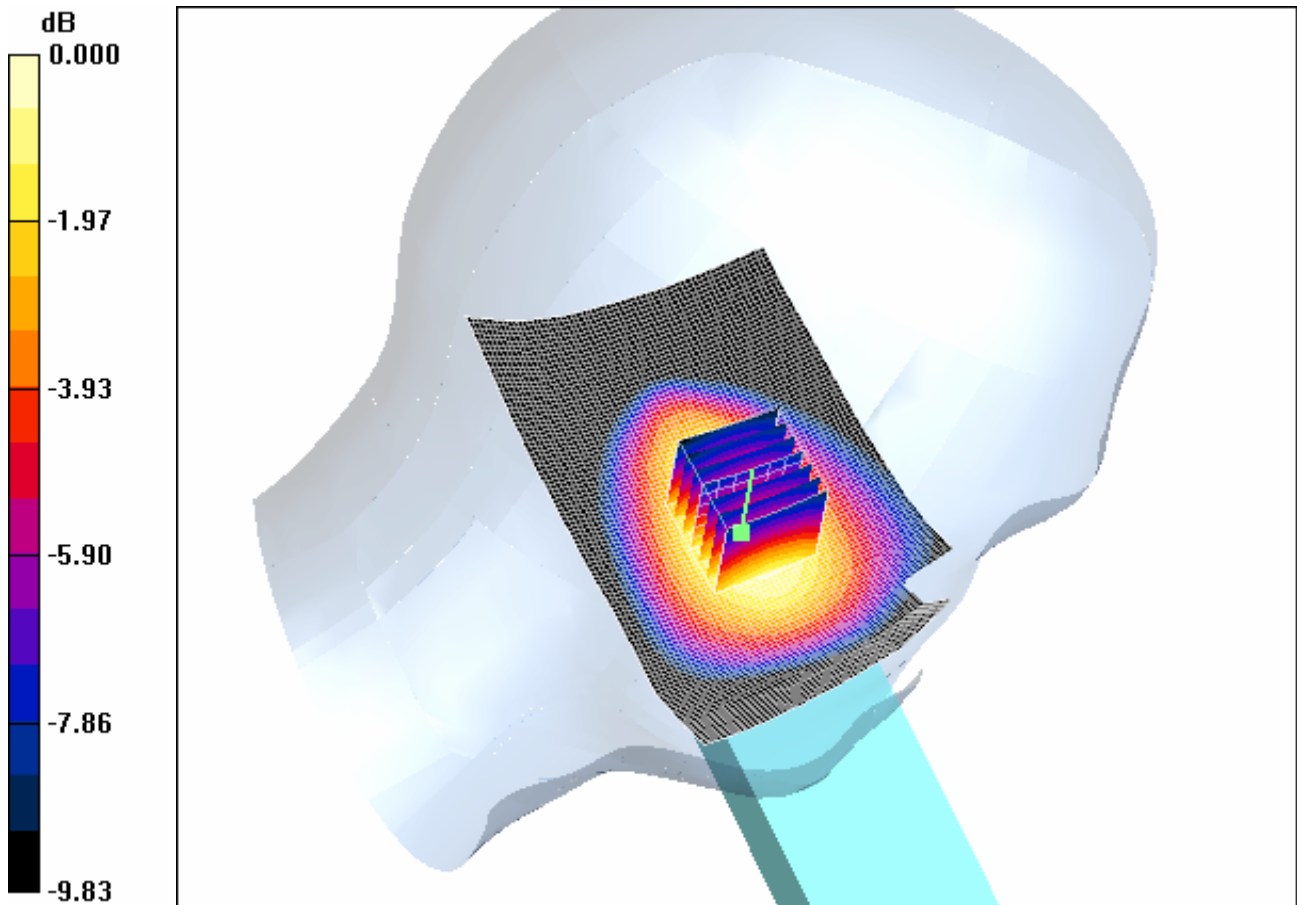

0 dB = 0.568mW/g

4.7RightHandSide-Cheek-GSM850-Low

Date/Time: 2006-7-6 16:24:53

Test Laboratory: SGS-GSM

FCC-OET65-RightHandSide-Cheek-GSM850-Low

DUT: GSM10006703M-Head; Type: Head; Serial: 01090000000322-7

Communication System: GSM850-GSM Mode; Frequency: 824.2 MHz;Duty Cycle: 1:8.3

Medium: HSL850-Head Medium parameters used: $f = 824.2 \text{ MHz}$; $\sigma = 0.882 \text{ mho/m}$; $\epsilon_r = 42.4$; $\rho = 1000 \text{ kg/m}^3$

Phantom section: Right Section

Measurement Standard: DASY4 (High Precision Assessment)

DASY4 Configuration:

- Probe: ES3DV3 - SN3088; ConvF(5.91, 5.91, 5.91); Calibrated: 2005-9-13
- Sensor-Surface: 4mm (Mechanical Surface Detection)
- Electronics: DAE3 Sn569; Calibrated: 2005-11-17
- Phantom: SAM 12; Type: SAM V4.0; Serial: TP-1283
- Measurement SW: DASY4, V4.6 Build 23; Postprocessing SW: SEMCAD, V1.8 Build 160

Cheek position - Low/Area Scan (71x111x1): Measurement grid: dx=15mm, dy=15mm

Maximum value of SAR (interpolated) = 0.663 mW/g

Cheek position - Low/Zoom Scan (7x7x7)/Cube 0: Measurement grid: dx=5mm, dy=5mm, dz=5mm

Reference Value = 10.1 V/m; Power Drift = -0.040 dB

Peak SAR (extrapolated) = 0.850 W/kg

SAR(1 g) = 0.600 mW/g; SAR(10 g) = 0.403 mW/g

Maximum value of SAR (measured) = 0.646 mW/g

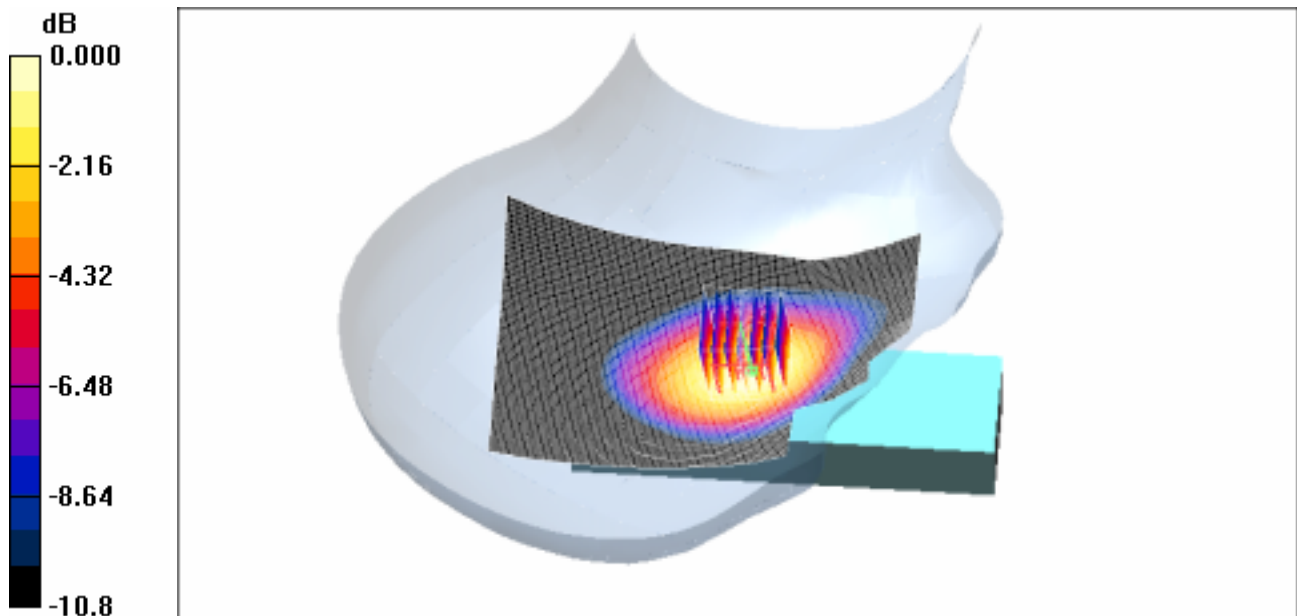

0 dB = 0.646mW/g

4.8RightHandSide-Cheek-GSM850-Middle

Date/Time: 2006-7-6 16:51:30

Test Laboratory: SGS-GSM

FCC-OET65-RightHandSide-Cheek-GSM850-Mid

DUT: GSM10006703M-Head; Type: Head; Serial: 01090000000322-7

Communication System: GSM850-GSM Mode; Frequency: 836.4 MHz;Duty Cycle: 1:8.3

Medium: HSL850-Head Medium parameters used: $f = 836.4 \text{ MHz}$; $\epsilon = 0.901 \text{ mho/m}$; $r = 42.2$; $\rho = 1000 \text{ kg/m}^3$

Phantom section: Right Section

Measurement Standard: DAS4 (High Precision Assessment)

DASY4 Configuration:

- Probe: ES3DV3 - SN3088; ConvF(5.91, 5.91, 5.91); Calibrated: 2005-9-13
- Sensor-Surface: 4mm (Mechanical Surface Detection)
- Electronics: DAE3 Sn569; Calibrated: 2005-11-17
- Phantom: SAM 12; Type: SAM V4.0; Serial: TP-1283
- Measurement SW: DAS4, V4.6 Build 23; Postprocessing SW: SEMCAD, V1.8 Build 160

Cheek position - Middle/Area Scan (71x111x1): Measurement grid: $dx=15\text{mm}$, $dy=15\text{mm}$

Maximum value of SAR (interpolated) = 0.965 mW/g

Cheek position - Middle/Zoom Scan (7x7x7) (7x7x7)/Cube 0: Measurement grid: $dx=5\text{mm}$, $dy=5\text{mm}$, $dz=5\text{mm}$

Reference Value = 12.1 V/m; Power Drift = 0.081 dB

Peak SAR (extrapolated) = 1.29 W/kg

SAR(1 g) = 0.896 mW/g; SAR(10 g) = 0.597 mW/g

Maximum value of SAR (measured) = 0.960 mW/g

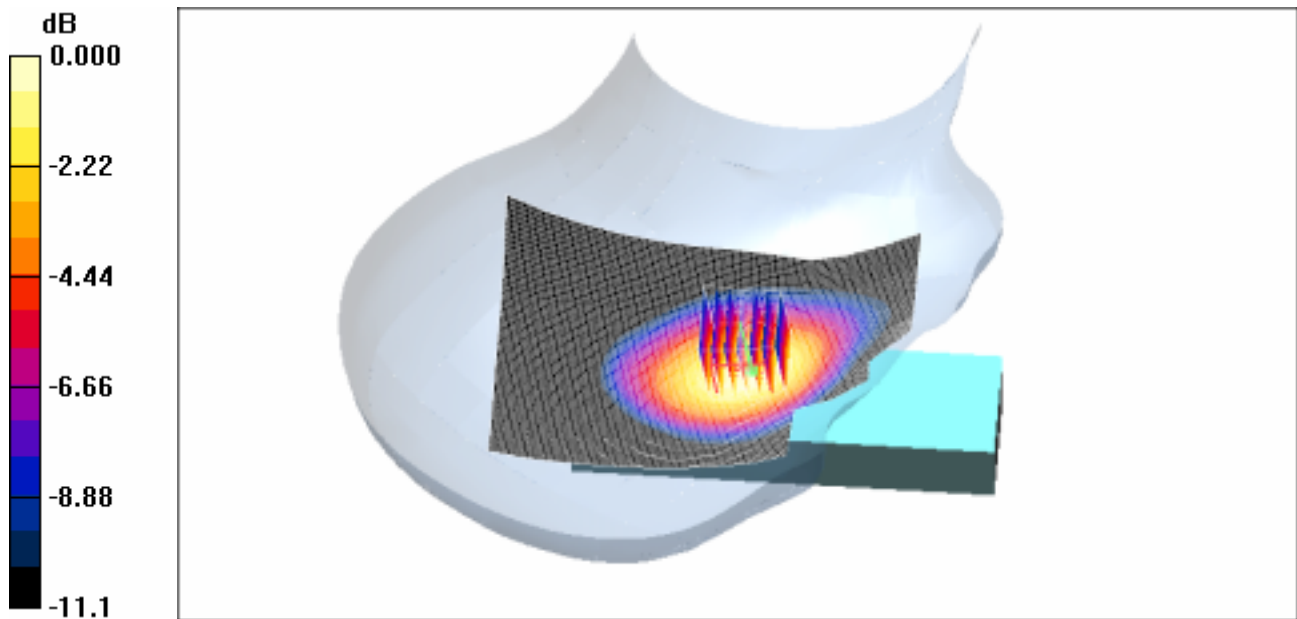

0 dB = 0.960mW/g

4.9RightHandSide-Cheek-GSM850-High

Date/Time: 2006-7-7 8:51:14

Test Laboratory: SGS-GSM

FCC-OET65-RightHandSide-Cheek-GSM850-High

DUT: GSM10006703M-Head; Type: Head; Serial: 01090000000322-7

Communication System: GSM850-GSM Mode; Frequency: 848.8 MHz; Duty Cycle: 1:8.3

Medium: HSL850-Head Medium parameters used: $f = 848.8 \text{ MHz}$; $\sigma = 0.921 \text{ mho/m}$; $\epsilon_r = 42.2$; $\rho = 1000 \text{ kg/m}^3$

Phantom section: Right Section

Measurement Standard: DASY4 (High Precision Assessment)

DASY4 Configuration:

- Probe: ES3DV3 - SN3088; ConvF(5.91, 5.91, 5.91); Calibrated: 2005-9-13
- Sensor-Surface: 4mm (Mechanical Surface Detection)
- Electronics: DAE3 Sn569; Calibrated: 2005-11-17

- Phantom: SAM 12; Type: SAM V4.0; Serial: TP-1283
- Measurement SW: DASY4, V4.6 Build 23; Postprocessing SW: SEMCAD, V1.8 Build 160

Cheek position - High/Area Scan (71x111x1): Measurement grid: dx=15mm, dy=15mm

Maximum value of SAR (interpolated) = 1.31 mW/g

Cheek position - High/Zoom Scan (7x7x7) (7x7x7)/Cube 0: Measurement grid: dx=5mm, dy=5mm, dz=5mm

Reference Value = 14.0 V/m; Power Drift = -0.406 dB

Peak SAR (extrapolated) = 1.68 W/kg

SAR(1 g) = 1.17 mW/g; SAR(10 g) = 0.779 mW/g

Maximum value of SAR (measured) = 1.23 mW/g

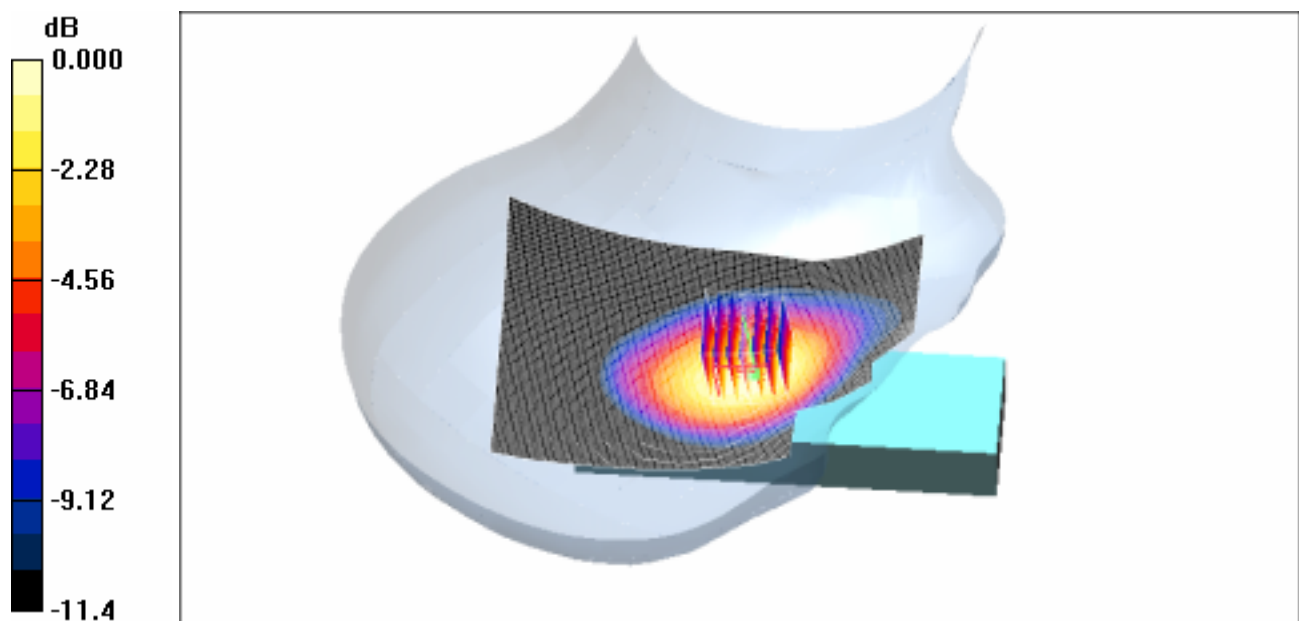

0 dB = 1.23mW/g

4.10RightHandSide-Tilt-GSM850-Low

Date/Time: 2006-7-7 9:31:51

Test Laboratory: SGS-GSM

FCC-OET65-RightHandSide-Tilt-GSM850-Low

DUT: GSM10006703M-Head; Type: Head; Serial: 01090000000322-7

Communication System: GSM850-GSM Mode; Frequency: 824.2 MHz; Duty Cycle: 1:8.3

Medium: HSL850-Head Medium parameters used: $f = 824.2$ MHz; $\mu = 0.882$ mho/m; $\epsilon_r = 42.4$; $\rho = 1000$ kg/m³

Phantom section: Right Section

Measurement Standard: DASY4 (High Precision Assessment)

DASY4 Configuration:

- Probe: ES3DV3 - SN3088; ConvF(5.91, 5.91, 5.91); Calibrated: 2005-9-13
- Sensor-Surface: 4mm (Mechanical Surface Detection)
- Electronics: DAE3 Sn569; Calibrated: 2005-11-17
- Phantom: SAM 12; Type: SAM V4.0; Serial: TP-1283
- Measurement SW: DASY4, V4.6 Build 23; Postprocessing SW: SEMCAD, V1.8 Build 160

Tilt position - Low/Area Scan (61x101x1): Measurement grid: dx=15mm, dy=15mm

Maximum value of SAR (interpolated) = 0.192 mW/g

Tilt position - Low/Zoom Scan (7x7x7) (7x7x7)/Cube 0: Measurement grid: dx=5mm, dy=5mm, dz=5mm

Reference Value = 11.4 V/m; Power Drift = -0.028 dB

Peak SAR (extrapolated) = 0.243 W/kg

SAR(1 g) = 0.181 mW/g; SAR(10 g) = 0.129 mW/g

Maximum value of SAR (measured) = 0.193 mW/g

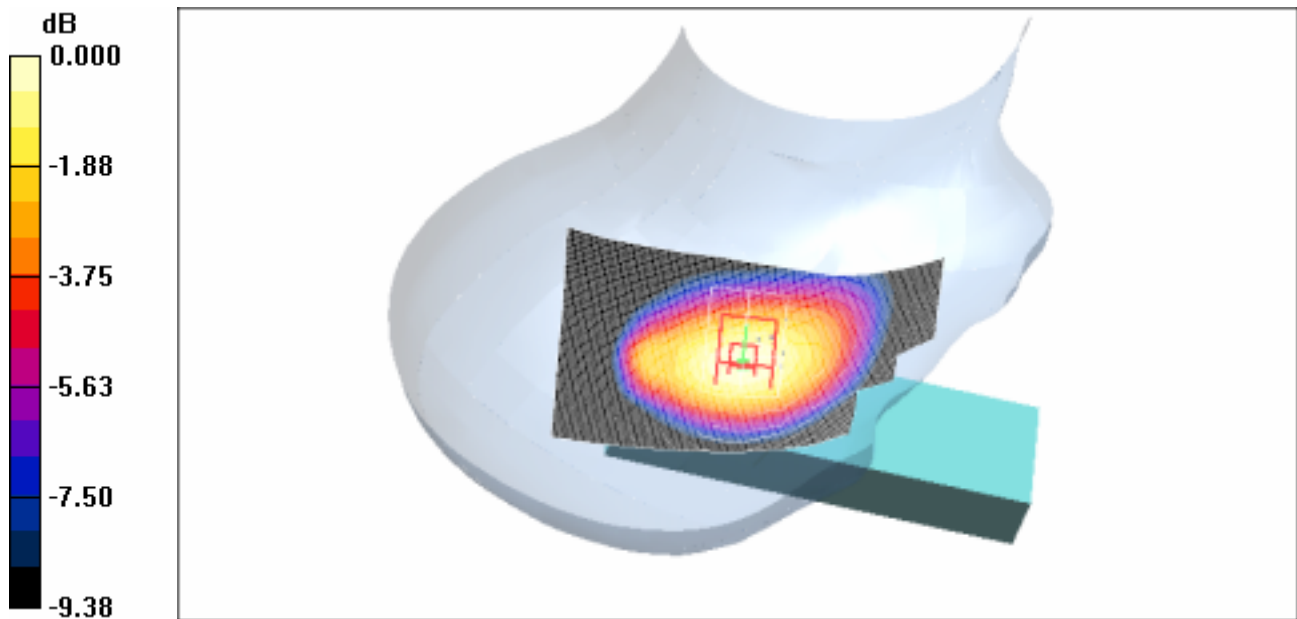

0 dB = 0.193mW/g

4.11 RightHandSide-Tilt-GSM850-Middle

Date/Time: 2006-7-7 9:56:00

Test Laboratory: SGS-GSM

FCC-OET65-RightHandSide-Tilt-GSM850-Mid

DUT: GSM10006703M-Head; Type: Head; Serial: 01090000000322-7

Communication System: GSM850-GSM Mode; Frequency: 836.4 MHz; Duty Cycle: 1:8.3

Medium: HSL850-Head Medium parameters used: $f = 836.4 \text{ MHz}$; $\sigma = 0.901 \text{ mho/m}$; $\epsilon_r = 42.2$; $\rho = 1000 \text{ kg/m}^3$

Phantom section: Right Section

Measurement Standard: DASY4 (High Precision Assessment)

DASY4 Configuration:

- Probe: ES3DV3 - SN3088; ConvF(5.91, 5.91, 5.91); Calibrated: 2005-9-13
- Sensor-Surface: 4mm (Mechanical Surface Detection)
- Electronics: DAE3 Sn569; Calibrated: 2005-11-17

- Phantom: SAM 12; Type: SAM V4.0; Serial: TP-1283
- Measurement SW: DASY4, V4.6 Build 23; Postprocessing SW: SEMCAD, V1.8 Build 160

Tilt position - Middle/Area Scan (61x101x1): Measurement grid: dx=15mm, dy=15mm

Maximum value of SAR (interpolated) = 0.284 mW/g

Tilt position - Middle/Zoom Scan (7x7x7)/Cube 0: Measurement grid: dx=5mm, dy=5mm, dz=5mm

Reference Value = 13.7 V/m; Power Drift = -0.005 dB

Peak SAR (extrapolated) = 0.355 W/kg

SAR(1 g) = 0.265 mW/g; SAR(10 g) = 0.188 mW/g

Maximum value of SAR (measured) = 0.282 mW/g

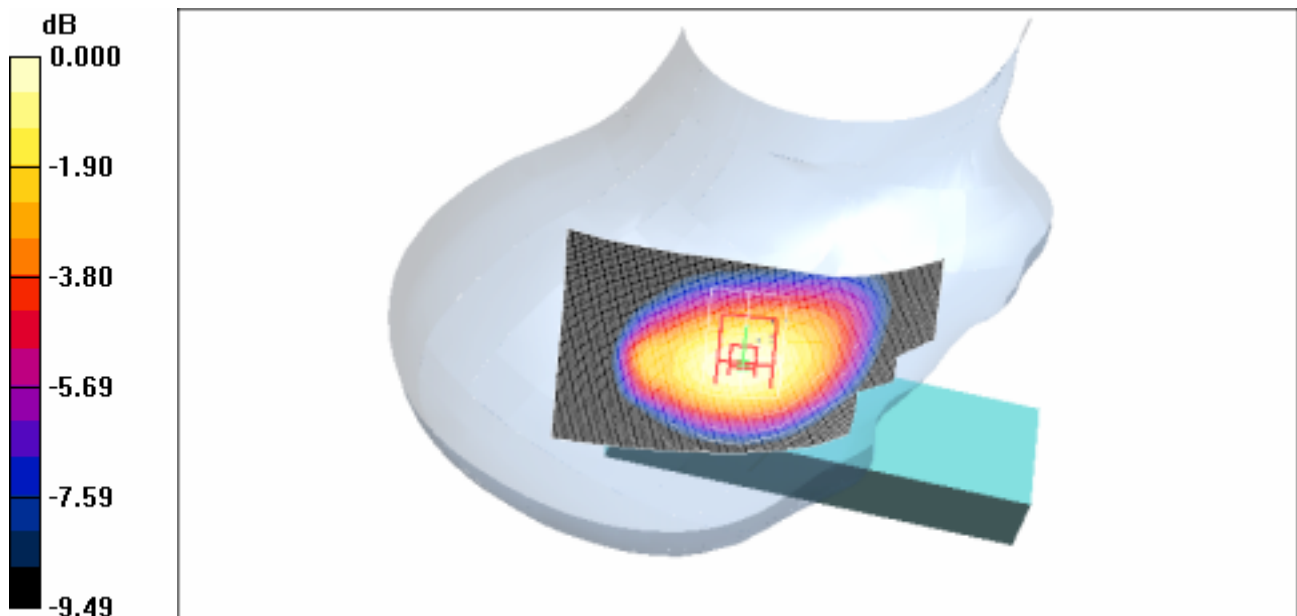

0 dB = 0.282mW/g

4.12RightHandSide-Tilt-GSM850-High

Date/Time: 2006-7-7 10:20:07

Test Laboratory: SGS-GSM

FCC-OET65-RightHandSide-Tilt-GSM850-High

DUT: GSM10006703M-Head; Type: Head; Serial: 01090000000322-7

Communication System: GSM850-GSM Mode; Frequency: 848.8 MHz; Duty Cycle: 1:8.3

Medium: HSL850-Head Medium parameters used: $f = 848.8$ MHz; $\sigma = 0.921$ mho/m; $\epsilon_r = 42.2$; $\rho = 1000$ kg/m³

Phantom section: Right Section

Measurement Standard: DASYS4 (High Precision Assessment)

DASY4 Configuration:

- Probe: ES3DV3 - SN3088; ConvF(5.91, 5.91, 5.91); Calibrated: 2005-9-13
- Sensor-Surface: 4mm (Mechanical Surface Detection)
- Electronics: DAE3 Sn569; Calibrated: 2005-11-17
- Phantom: SAM 12; Type: SAM V4.0; Serial: TP-1283
- Measurement SW: DASYS4, V4.6 Build 23; Postprocessing SW: SEMCAD, V1.8 Build 160

Tilt position - High/Area Scan (61x91x1): Measurement grid: dx=15mm, dy=15mm

Maximum value of SAR (interpolated) = 0.446 mW/g

Tilt position - High/Zoom Scan (7x7x7) (7x7x7)/Cube 0: Measurement grid: dx=5mm, dy=5mm, dz=5mm

Reference Value = 17.0 V/m; Power Drift = -0.039 dB

Peak SAR (extrapolated) = 0.560 W/kg

SAR(1 g) = 0.414 mW/g; SAR(10 g) = 0.292 mW/g

Maximum value of SAR (measured) = 0.444 mW/g

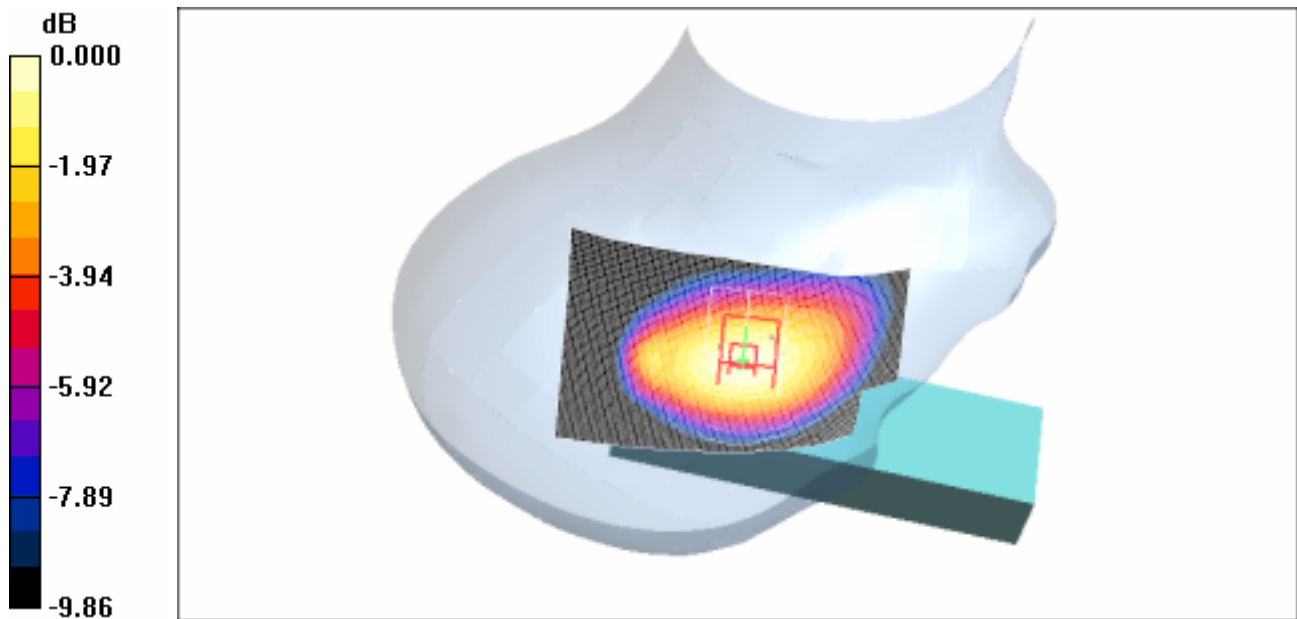

0 dB = 0.444mW/g

4.13 Body-Worn-GSM850-GPRS-Low

Date/Time: 2006-7-6 10:47:48

Test Laboratory: SGS-GSM

FCC-OET65-Body-Worn-GSM850-GPRS-Low-2cm

DUT: GSM10006703M-Body; Type: Body; Serial: 01090000000322-7

Communication System: GSM850-GPRS Mode; Frequency: 824.2 MHz; Duty Cycle: 1:4

Medium: HSL850-Body Medium parameters used: $f = 824.2 \text{ MHz}$; $\sigma = 0.984 \text{ mho/m}$; $\epsilon_r = 52.6$; $\rho = 1000 \text{ kg/m}^3$

Phantom section: Flat Section

Measurement Standard: DASY4 (High Precision Assessment)

DASY4 Configuration:

- Probe: ES3DV3 - SN3088; ConvF(5.83, 5.83, 5.83); Calibrated: 2005-9-13
- Sensor-Surface: 4mm (Mechanical Surface Detection)
- Electronics: DAE3 Sn569; Calibrated: 2005-11-17

- Phantom: SAM 12; Type: SAM V4.0; Serial: TP-1283
- Measurement SW: DASY4, V4.6 Build 23; Postprocessing SW: SEMCAD, V1.8 Build 160

Body Worn - Low/Area Scan (51x91x1): Measurement grid: dx=15mm, dy=15mm

Maximum value of SAR (interpolated) = 0.174 mW/g

Body Worn - Low/Zoom Scan (7x7x7) (7x7x7)/Cube 0: Measurement grid: dx=5mm, dy=5mm,

dz=5mm

Reference Value = 12.8 V/m; Power Drift = -0.020 dB

Peak SAR (extrapolated) = 0.261 W/kg

SAR(1 g) = 0.167 mW/g; SAR(10 g) = 0.108 mW/g

Maximum value of SAR (measured) = 0.180 mW/g

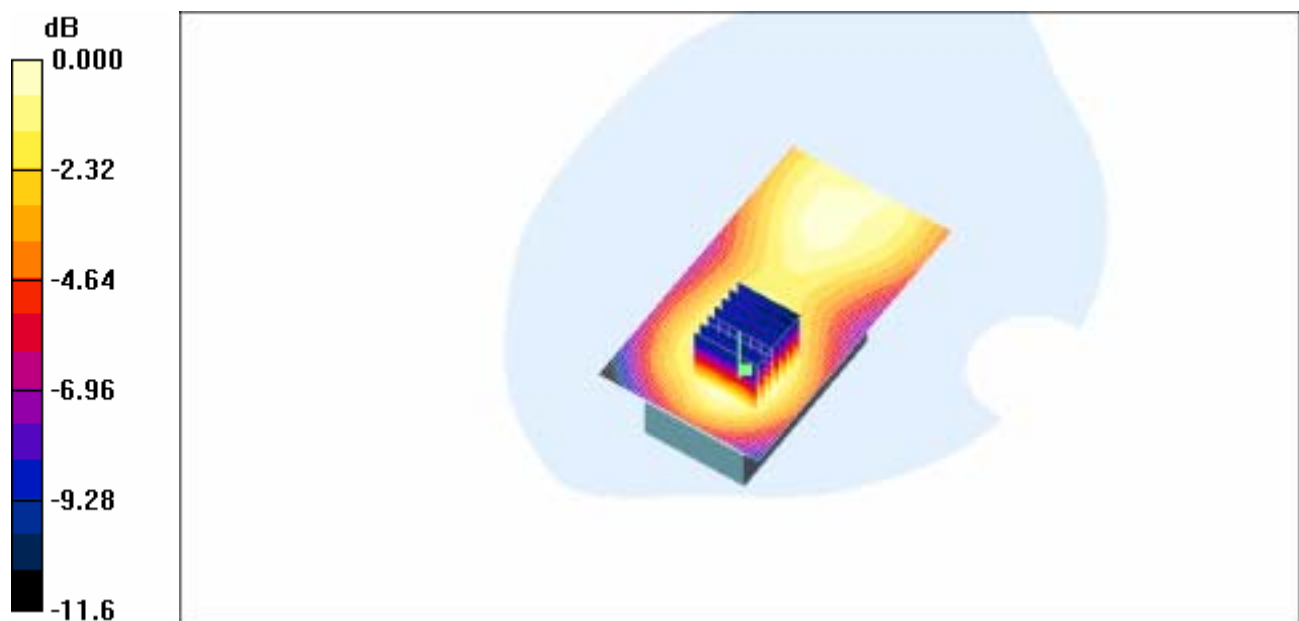

0 dB = 0.180mW/g

4.14 Body-Worn-GSM850-GPRS-Middle

Date/Time: 2006-7-6 11:09:38

Test Laboratory: SGS-GSM

FCC-OET65-Body-Worn-GSM850-GPRS-Mid-2cm

DUT: GSM10006703M-Body; Type: Body; Serial: 01090000000322-7

Communication System: GSM850-GPRS Mode; Frequency: 836.4 MHz; Duty Cycle: 1:4

Medium: HSL850-Body Medium parameters used: $f = 836.4 \text{ MHz}$; $\mu = 0.998 \text{ mho/m}$; $r = 52.5$; $\rho = 1000 \text{ kg/m}^3$

Phantom section: Flat Section

Measurement Standard: DASY4 (High Precision Assessment)

DASY4 Configuration:

- Probe: ES3DV3 - SN3088; ConvF(5.83, 5.83, 5.83); Calibrated: 2005-9-13
- Sensor-Surface: 4mm (Mechanical Surface Detection)
- Electronics: DAE3 Sn569; Calibrated: 2005-11-17
- Phantom: SAM 12; Type: SAM V4.0; Serial: TP-1283
- Measurement SW: DASY4, V4.6 Build 23; Postprocessing SW: SEMCAD, V1.8 Build 160

Body Worn - Middle/Area Scan (51x91x1): Measurement grid: $dx=15\text{mm}$, $dy=15\text{mm}$

Maximum value of SAR (interpolated) = 0.305 mW/g

Body Worn - Middle/Zoom Scan (7x7x7)/Cube 0: Measurement grid: $dx=5\text{mm}$, $dy=5\text{mm}$, $dz=5\text{mm}$

Reference Value = 13.9 V/m; Power Drift = 0.054 dB

Peak SAR (extrapolated) = 0.438 W/kg

SAR(1 g) = 0.285 mW/g; SAR(10 g) = 0.184 mW/g

Maximum value of SAR (measured) = 0.305 mW/g

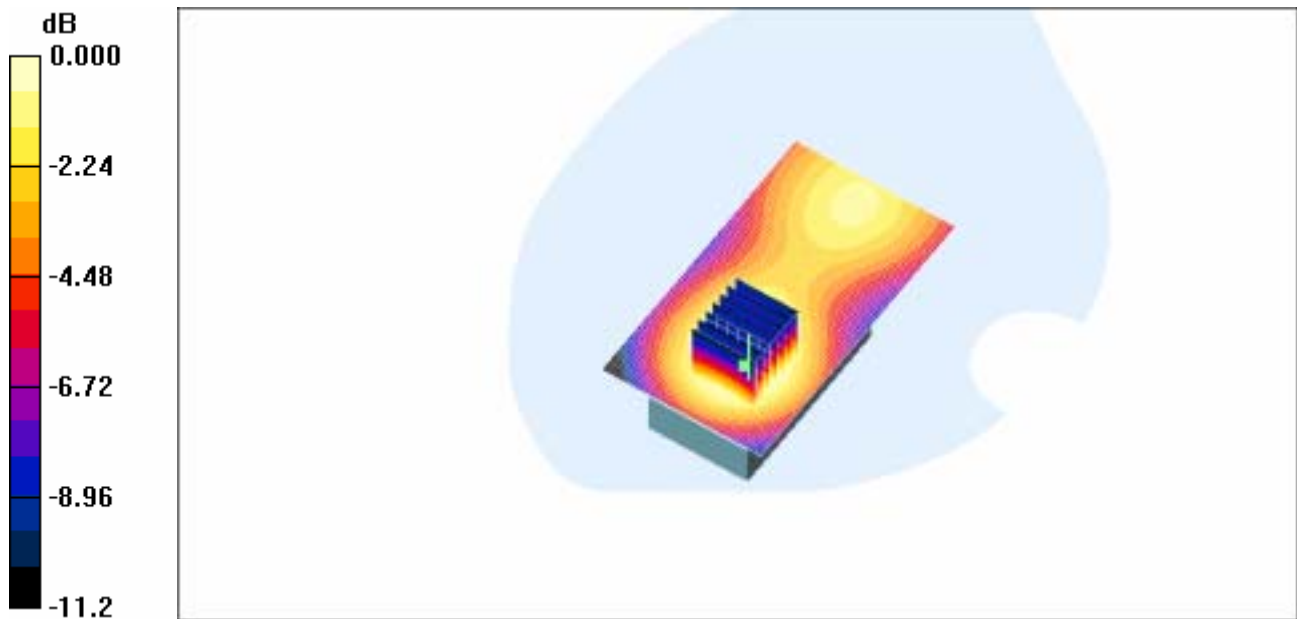

0 dB = 0.305mW/g

4.15 Body-Worn-GSM850-GPRS-High

Date/Time: 2006-7-6 12:24:08

Test Laboratory: SGS-GSM

FCC-OET65-Body-Worn-GSM850-GPRS-High-2cm

DUT: GSM10006703M-Body; Type: Body; Serial: 01090000000322-7

Communication System: GSM850-GPRS Mode; Frequency: 848.8 MHz; Duty Cycle: 1:4

Medium: HSL850-Body Medium parameters used: $f = 848.8 \text{ MHz}$; $\sigma = 1.01 \text{ mho/m}$; $\epsilon_r = 52.5$; $\rho = 1000 \text{ kg/m}^3$

Phantom section: Flat Section

Measurement Standard: DASY4 (High Precision Assessment)

DASY4 Configuration:

- Probe: ES3DV3 - SN3088; ConvF(5.83, 5.83, 5.83); Calibrated: 2005-9-13
- Sensor-Surface: 4mm (Mechanical Surface Detection)
- Electronics: DAE3 Sn569; Calibrated: 2005-11-17

- Phantom: SAM 12; Type: SAM V4.0; Serial: TP-1283
- Measurement SW: DASY4, V4.6 Build 23; Postprocessing SW: SEMCAD, V1.8 Build 160

Body Worn - High/Area Scan (51x91x1): Measurement grid: dx=15mm, dy=15mm

Maximum value of SAR (interpolated) = 0.536 mW/g

Body Worn - High/Zoom Scan (7x7x7) (7x7x7)/Cube 0: Measurement grid: dx=5mm, dy=5mm, dz=5mm

Reference Value = 16.0 V/m; Power Drift = -0.292 dB

Peak SAR (extrapolated) = 0.740 W/kg

SAR(1 g) = 0.480 mW/g; SAR(10 g) = 0.306 mW/g

Maximum value of SAR (measured) = 0.513 mW/g

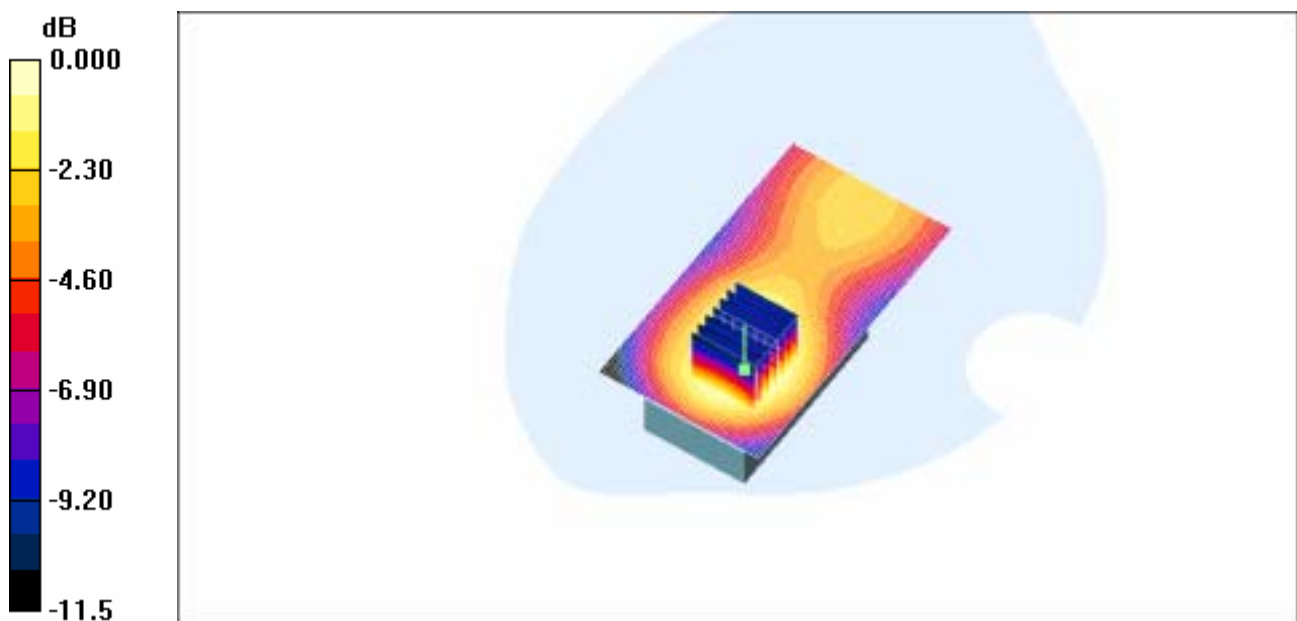

0 dB = 0.513mW/g

4.16LeftHandSide-Cheek-PCS1900-Low

Date/Time: 2006-7-12 13:58:07

Test Laboratory: SGS-GSM

FCC-OET65-LeftHandSide-Cheek-PCS1900-Low

DUT: GSM10006703M-Head; Type: Head; Serial: 01090000000322-7

Communication System: PCS1900-GSM Mode; Frequency: 1850.2 MHz; Duty Cycle: 1:8.3

Medium: HSL1900 Medium parameters used: $f = 1850.2$ MHz; $\sigma = 1.42$ mho/m; $\epsilon_r = 40.5$; $\rho = 1000$ kg/m³

Phantom section: Left Section

Measurement Standard: DASY4 (High Precision Assessment)

DASY4 Configuration:

- Probe: ES3DV3 - SN3088; ConvF(4.93, 4.93, 4.93); Calibrated: 2005-9-13
- Sensor-Surface: 4mm (Mechanical Surface Detection)
- Electronics: DAE3 Sn569; Calibrated: 2005-11-17
- Phantom: SAM 12; Type: SAM V4.0; Serial: TP-1283
- Measurement SW: DASY4, V4.6 Build 23; Postprocessing SW: SEMCAD, V1.8 Build 160

Cheek position - Low/Area Scan (71x111x1): Measurement grid: dx=15mm, dy=15mm

Maximum value of SAR (interpolated) = 0.344 mW/g

Cheek position - Low/Zoom Scan (7x7x7) (7x7x7)/Cube 0: Measurement grid: dx=5mm, dy=5mm, dz=5mm

Reference Value = 4.17 V/m; Power Drift = -0.375 dB

Peak SAR (extrapolated) = 0.450 W/kg

SAR(1 g) = 0.307 mW/g; SAR(10 g) = 0.187 mW/g

Maximum value of SAR (measured) = 0.333 mW/g

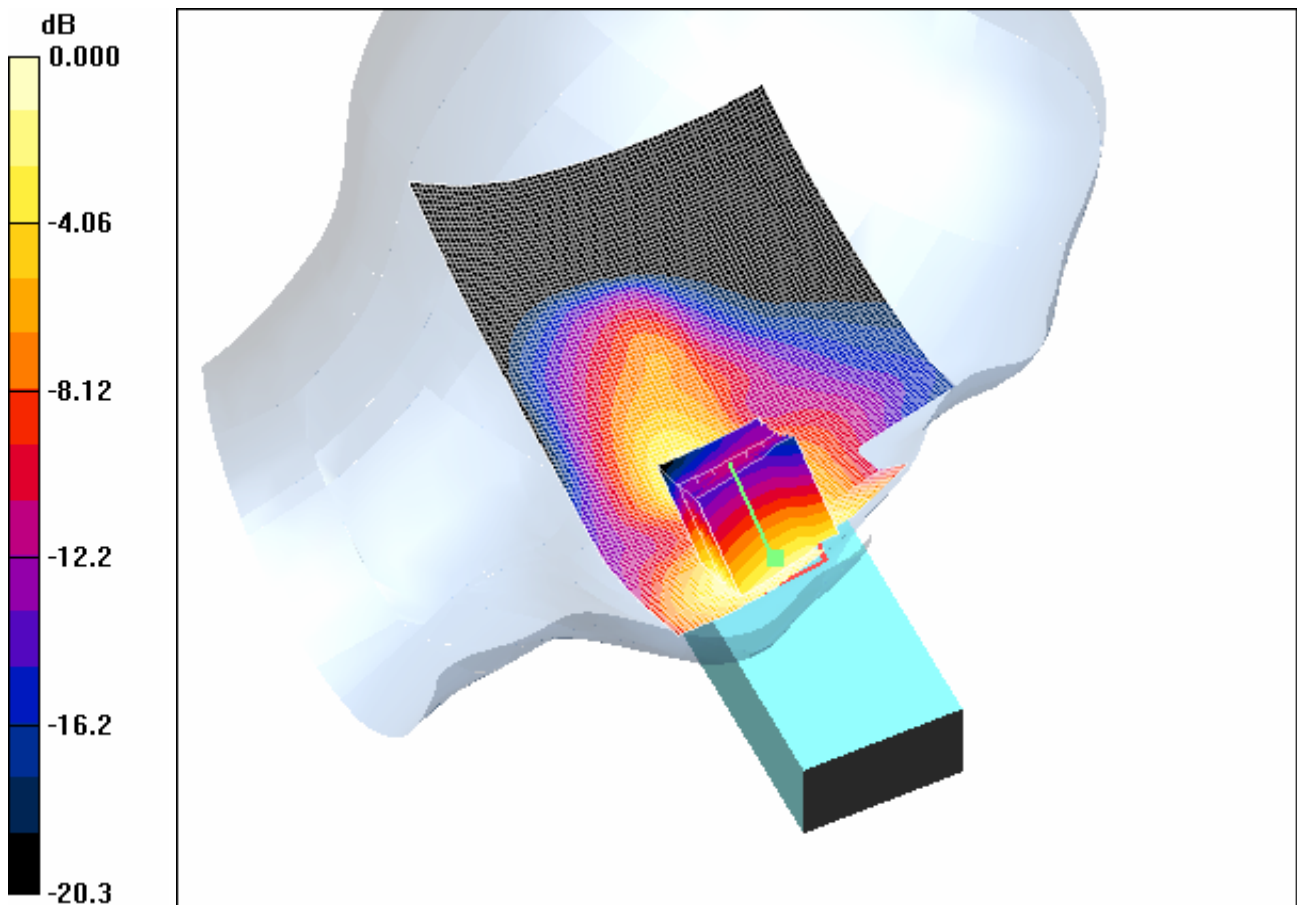

0 dB = 0.333mW/g

4.17LeftHandSide-Cheek-PCS1900-Middle

Date/Time: 2006-7-12 12:48:31

Test Laboratory: SGS-GSM

FCC-OET65-LeftHandSide-Cheek-PCS1900-Mid

DUT: GSM10006703M-Head; Type: Head; Serial: 01090000000322-7

Communication System: PCS1900-GSM Mode; Frequency: 1880 MHz;Duty Cycle: 1:8.3

Medium: HSL1900 Medium parameters used: $f = 1880$ MHz; $\sigma = 1.44$ mho/m; $\epsilon_r = 40.3$; $\rho = 1000$ kg/m³

Phantom section: Left Section

Measurement Standard: DASY4 (High Precision Assessment)

DASY4 Configuration:

- Probe: ES3DV3 - SN3088; ConvF(4.93, 4.93, 4.93); Calibrated: 2005-9-13
- Sensor-Surface: 4mm (Mechanical Surface Detection)
- Electronics: DAE3 Sn569; Calibrated: 2005-11-17
- Phantom: SAM 12; Type: SAM V4.0; Serial: TP-1283
- Measurement SW: DASY4, V4.6 Build 23; Postprocessing SW: SEMCAD, V1.8 Build 160

Cheek position - Middle/Area Scan (71x111x1): Measurement grid: dx=15mm, dy=15mm

Maximum value of SAR (interpolated) = 0.367 mW/g

Cheek position - Middle/Zoom Scan (7x7x7)/Cube 0: Measurement grid: dx=5mm, dy=5mm,
dz=5mm

Reference Value = 4.35 V/m; Power Drift = -0.264 dB

Peak SAR (extrapolated) = 0.492 W/kg

SAR(1 g) = 0.330 mW/g; SAR(10 g) = 0.198 mW/g

Maximum value of SAR (measured) = 0.357 mW/g

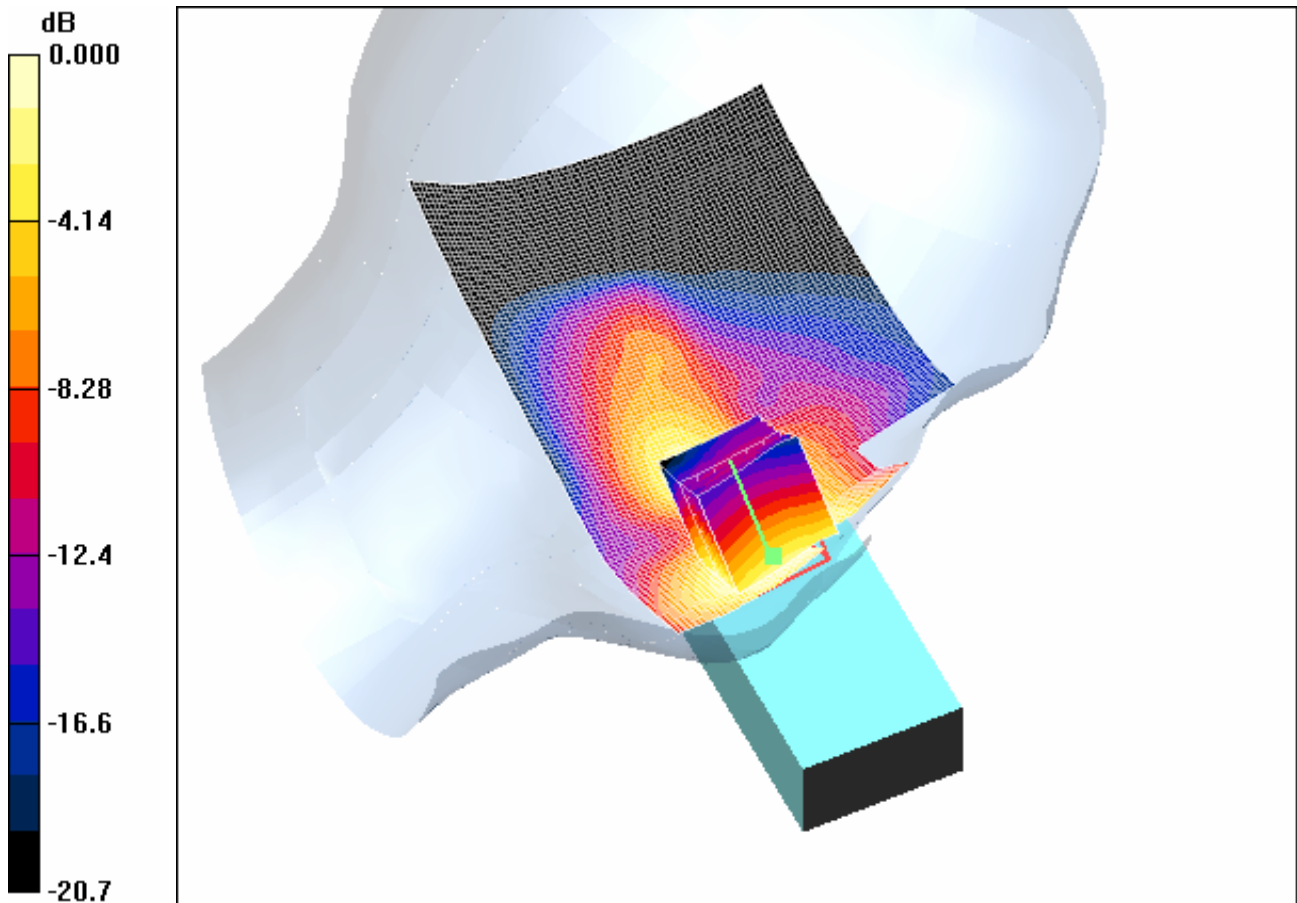

0 dB = 0.357mW/g

4.18LeftHandSide-Cheek-PCS1900-High

Date/Time: 2006-7-12 13:23:42

Test Laboratory: SGS-GSM

FCC-OET65-LeftHandSide-Cheek-PCS1900-High

DUT: GSM10006703M-Head; Type: Head; Serial: 01090000000322-7

Communication System: PCS1900-GSM Mode; Frequency: 1909.8 MHz;Duty Cycle: 1:8.3

Medium: HSL1900 Medium parameters used: $f = 1909.8 \text{ MHz}$; $\sigma = 1.47 \text{ mho/m}$; $\epsilon_r = 40$; $\rho = 1000 \text{ kg/m}^3$

Phantom section: Left Section

Measurement Standard: DASY4 (High Precision Assessment)

DASY4 Configuration:

- Probe: ES3DV3 - SN3088; ConvF(4.93, 4.93, 4.93); Calibrated: 2005-9-13
- Sensor-Surface: 4mm (Mechanical Surface Detection)
- Electronics: DAE3 Sn569; Calibrated: 2005-11-17
- Phantom: SAM 12; Type: SAM V4.0; Serial: TP-1283
- Measurement SW: DASY4, V4.6 Build 23; Postprocessing SW: SEMCAD, V1.8 Build 160

Cheek position - High/Area Scan (71x111x1): Measurement grid: dx=15mm, dy=15mm

Maximum value of SAR (interpolated) = 0.303 mW/g

Cheek position - High/Zoom Scan (7x7x7) (7x7x7)/Cube 0: Measurement grid: dx=5mm, dy=5mm, dz=5mm

Reference Value = 4.00 V/m; Power Drift = 0.004 dB

Peak SAR (extrapolated) = 0.407 W/kg

SAR(1 g) = 0.273 mW/g; SAR(10 g) = 0.162 mW/g

Maximum value of SAR (measured) = 0.295 mW/g

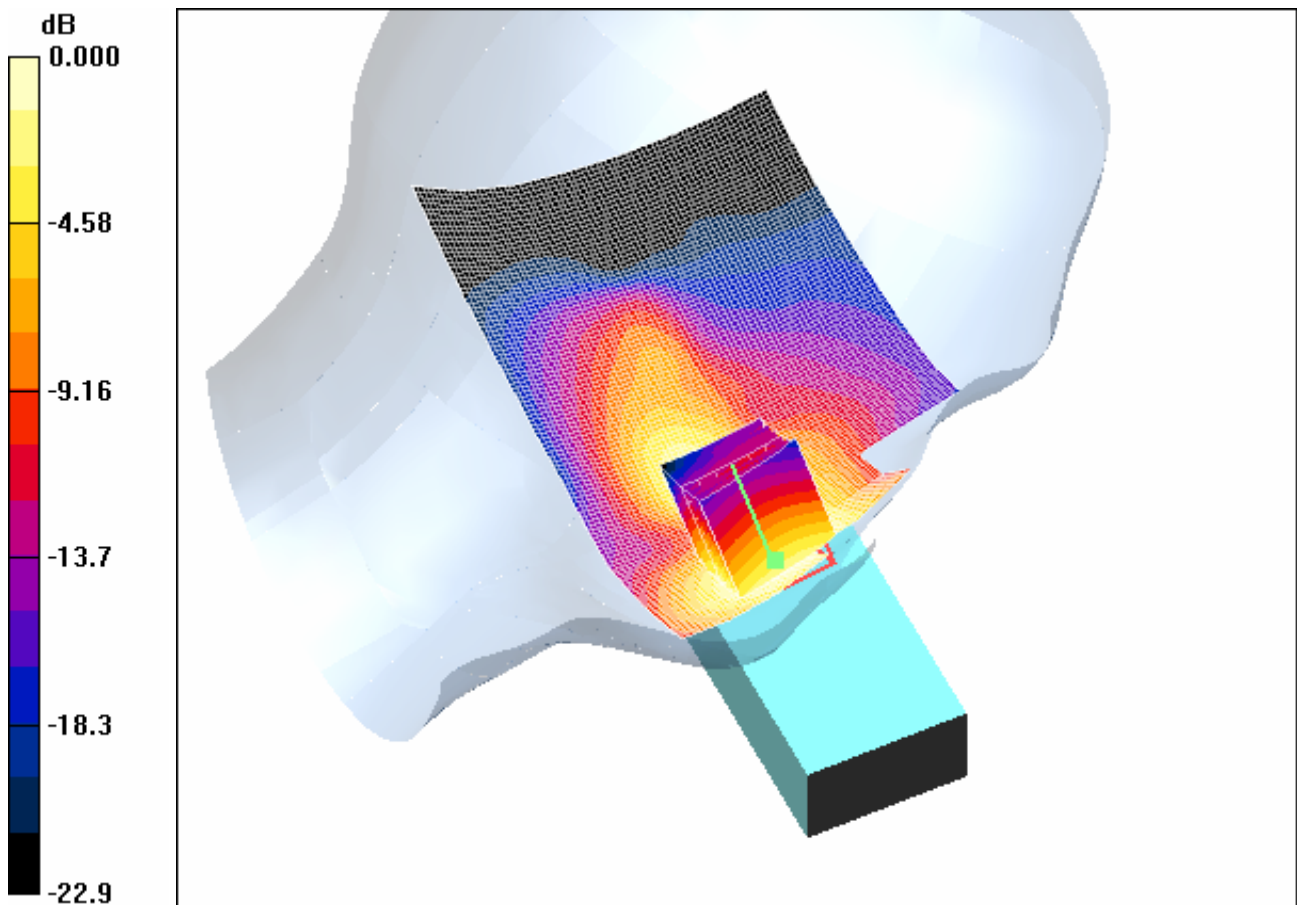

0 dB = 0.295mW/g

4.19LeftHandSide-Tilt-PCS1900-Low

Date/Time: 2006-7-12 14:43:40

Test Laboratory: SGS-GSM

FCC-OET65-LeftHandSide-Tilt-PCS1900-Low

DUT: GSM10006703M-Head; Type: Head; Serial: 01090000000322-7

Communication System: PCS1900-GSM Mode; Frequency: 1850.2 MHz;Duty Cycle: 1:8.3

Medium: HSL1900 Medium parameters used: $f = 1850.2 \text{ MHz}$; $\sigma = 1.42 \text{ mho/m}$; $\epsilon_r = 40.5$; $\rho = 1000 \text{ kg/m}^3$

Phantom section: Left Section

Measurement Standard: DASY4 (High Precision Assessment)

DASY4 Configuration:

- Probe: ES3DV3 - SN3088; ConvF(4.93, 4.93, 4.93); Calibrated: 2005-9-13
- Sensor-Surface: 4mm (Mechanical Surface Detection)
- Electronics: DAE3 Sn569; Calibrated: 2005-11-17
- Phantom: SAM 12; Type: SAM V4.0; Serial: TP-1283
- Measurement SW: DASY4, V4.6 Build 23; Postprocessing SW: SEMCAD, V1.8 Build 160

Tilt position - Low/Area Scan (71x111x1): Measurement grid: dx=15mm, dy=15mm

Maximum value of SAR (interpolated) = 0.076 mW/g

Tilt position - Low/Zoom Scan (7x7x7) (7x7x7)/Cube 0: Measurement grid: dx=5mm, dy=5mm, dz=5mm

Reference Value = 6.49 V/m; Power Drift = -0.208 dB

Peak SAR (extrapolated) = 0.097 W/kg

SAR(1 g) = 0.064 mW/g; SAR(10 g) = 0.038 mW/g

Maximum value of SAR (measured) = 0.070 mW/g

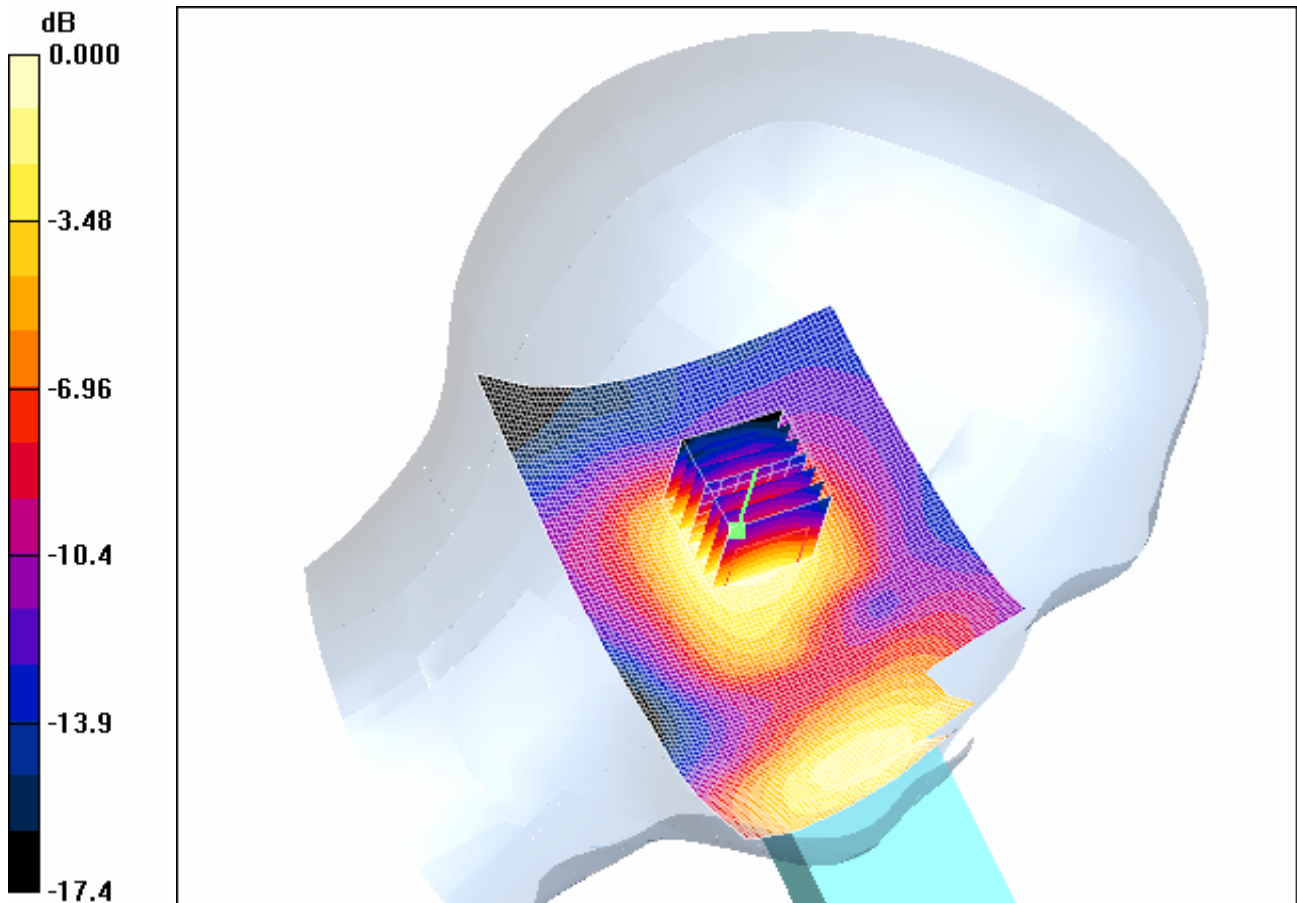

0 dB = 0.070mW/g

4.20LeftHandSide-Tilt-PCS1900-Middle

Date/Time: 2006-7-12 15:17:12

Test Laboratory: SGS-GSM

FCC-OET65-LeftHandSide-Tilt-PCS1900-Mid

DUT: GSM10006703M-Head; Type: Head; Serial: 01090000000322-7

Communication System: PCS1900-GSM Mode; Frequency: 1880 MHz;Duty Cycle: 1:8.3

Medium: HSL1900 Medium parameters used: $f = 1880$ MHz; $\sigma = 1.44$ mho/m; $\epsilon_r = 40.3$; $\rho = 1000$ kg/m³

Phantom section: Left Section

Measurement Standard: DASY4 (High Precision Assessment)

DASY4 Configuration:

- Probe: ES3DV3 - SN3088; ConvF(4.93, 4.93, 4.93); Calibrated: 2005-9-13
- Sensor-Surface: 4mm (Mechanical Surface Detection)
- Electronics: DAE3 Sn569; Calibrated: 2005-11-17
- Phantom: SAM 12; Type: SAM V4.0; Serial: TP-1283
- Measurement SW: DASY4, V4.6 Build 23; Postprocessing SW: SEMCAD, V1.8 Build 160

Tilt position - Middle/Area Scan (71x111x1): Measurement grid: dx=15mm, dy=15mm

Maximum value of SAR (interpolated) = 0.060 mW/g

Tilt position - Middle/Zoom Scan (7x7x7)/Cube 0: Measurement grid: dx=5mm, dy=5mm, dz=5mm

Reference Value = 5.77 V/m; Power Drift = -0.148 dB

Peak SAR (extrapolated) = 0.081 W/kg

SAR(1 g) = 0.051 mW/g; SAR(10 g) = 0.029 mW/g

Maximum value of SAR (measured) = 0.057 mW/g

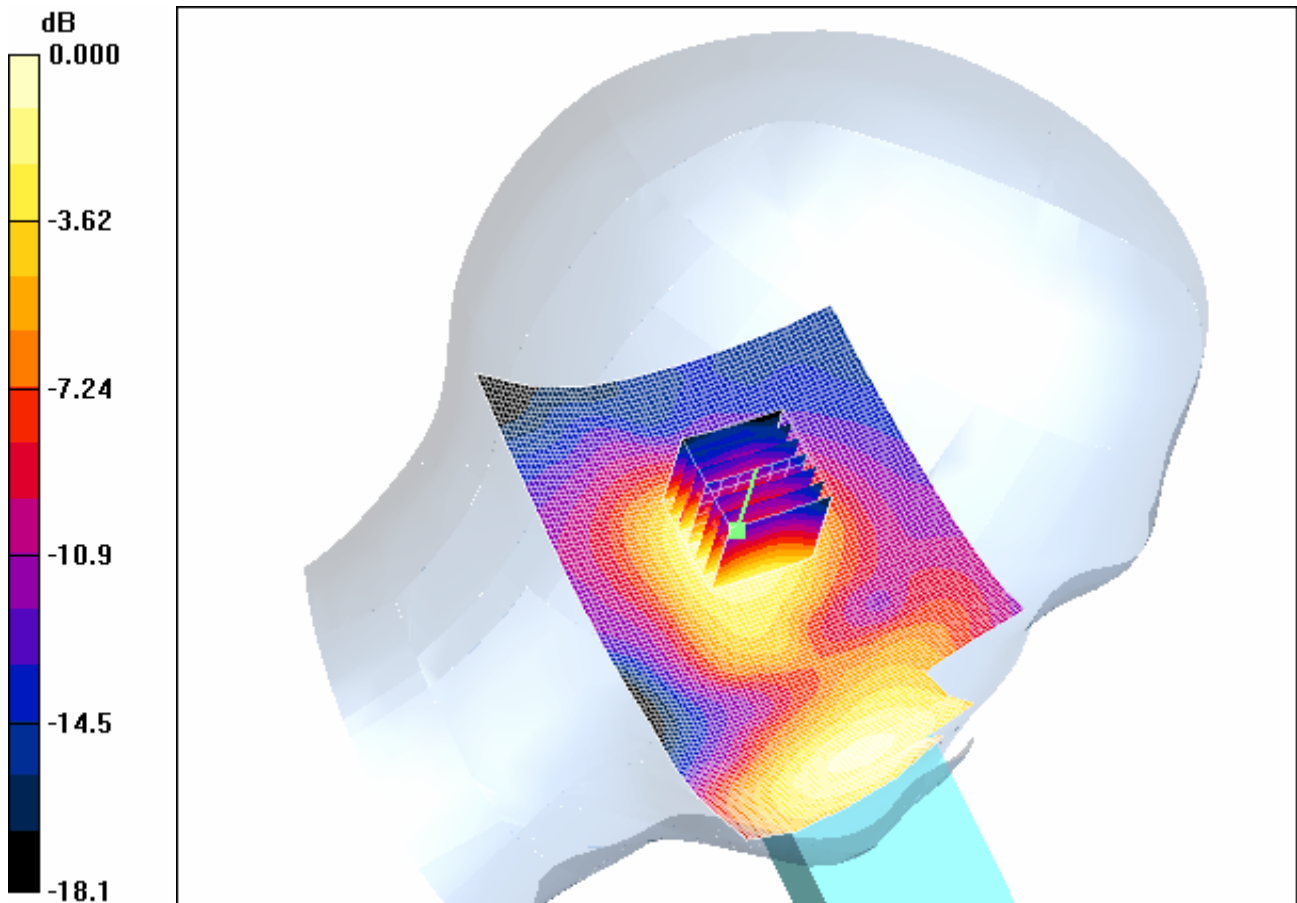

0 dB = 0.057mW/g

4.21LeftHandSide-Tilt-PCS1900-High

Date/Time: 2006-7-12 15:50:42

Test Laboratory: SGS-GSM

FCC-OET65-LeftHandSide-Tilt-PCS1900-High

DUT: GSM10006703M-Head; Type: Head; Serial: 01090000000322-7

Communication System: PCS1900-GSM Mode; Frequency: 1909.8 MHz; Duty Cycle: 1:8.3

Medium: HSL1900 Medium parameters used: $f = 1909.8 \text{ MHz}$; $\sigma = 1.47 \text{ mho/m}$; $\epsilon_r = 40$; $\rho = 1000 \text{ kg/m}^3$

Phantom section: Left Section

Measurement Standard: DASY4 (High Precision Assessment)

DASY4 Configuration:

- Probe: ES3DV3 - SN3088; ConvF(4.93, 4.93, 4.93); Calibrated: 2005-9-13
- Sensor-Surface: 4mm (Mechanical Surface Detection)
- Electronics: DAE3 Sn569; Calibrated: 2005-11-17
- Phantom: SAM 12; Type: SAM V4.0; Serial: TP-1283
- Measurement SW: DASY4, V4.6 Build 23; Postprocessing SW: SEMCAD, V1.8 Build 160

Tilt position - High/Area Scan (71x111x1): Measurement grid: dx=15mm, dy=15mm

Maximum value of SAR (interpolated) = 0.046 mW/g

Tilt position - High/Zoom Scan (7x7x7) (7x7x7)/Cube 0: Measurement grid: dx=5mm, dy=5mm, dz=5mm

Reference Value = 4.91 V/m; Power Drift = 0.049 dB

Peak SAR (extrapolated) = 0.063 W/kg

SAR(1 g) = 0.039 mW/g; SAR(10 g) = 0.022 mW/g

Maximum value of SAR (measured) = 0.043 mW/g

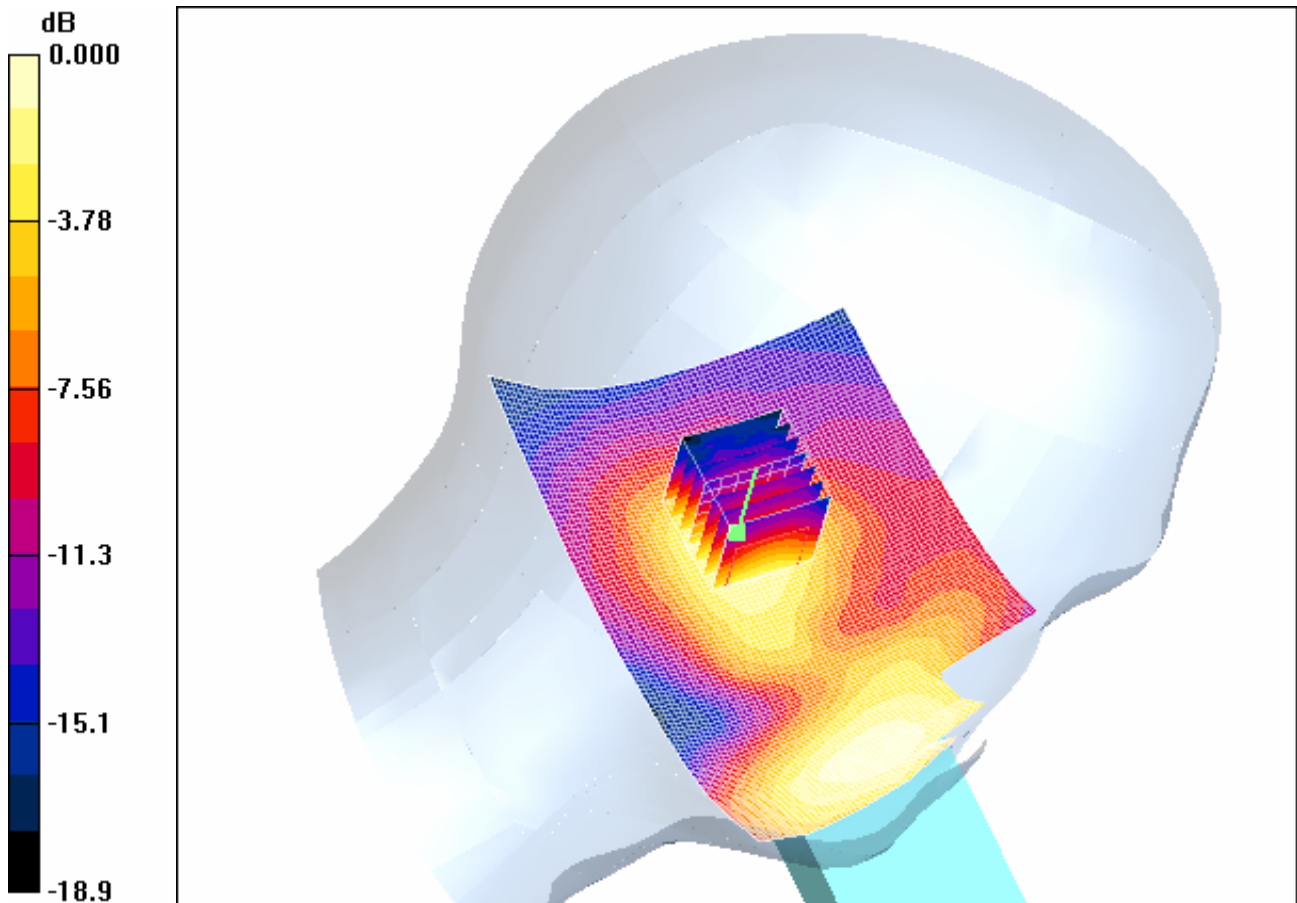

0 dB = 0.043mW/g

4.22RightHandSide-Cheek-PCS1900-Low

Date/Time: 2006-7-10 15:59:13

Test Laboratory: SGS-GSM

FCC-OET65-RightHandSide-Cheek-PCS1900-Low

DUT: GSM10006703M-Head; Type: Head; Serial: 01090000000322-7

Communication System: PCS1900-GSM Mode; Frequency: 1850.2 MHz; Duty Cycle: 1:8.3

Medium: HSL1900 Medium parameters used: $f = 1850.2 \text{ MHz}$; $\sigma = 1.42 \text{ mho/m}$; $\epsilon_r = 40.5$; $\rho = 1000 \text{ kg/m}^3$

Phantom section: Right Section

Measurement Standard: DASY4 (High Precision Assessment)

DASY4 Configuration:

- Probe: ES3DV3 - SN3088; ConvF(4.93, 4.93, 4.93); Calibrated: 2005-9-13
- Sensor-Surface: 4mm (Mechanical Surface Detection)
- Electronics: DAE3 Sn569; Calibrated: 2005-11-17
- Phantom: SAM 12; Type: SAM V4.0; Serial: TP-1283
- Measurement SW: DASY4, V4.6 Build 23; Postprocessing SW: SEMCAD, V1.8 Build 160

Cheek position - Low/Area Scan (61x101x1): Measurement grid: dx=15mm, dy=15mm

Maximum value of SAR (interpolated) = 0.387 mW/g

Cheek position - Low/Zoom Scan (7x7x7) (7x7x7)/Cube 0: Measurement grid: dx=5mm, dy=5mm, dz=5mm

Reference Value = 5.16 V/m; Power Drift = -0.415 dB

Peak SAR (extrapolated) = 0.511 W/kg

SAR(1 g) = 0.345 mW/g; SAR(10 g) = 0.208 mW/g

Maximum value of SAR (measured) = 0.373 mW/g

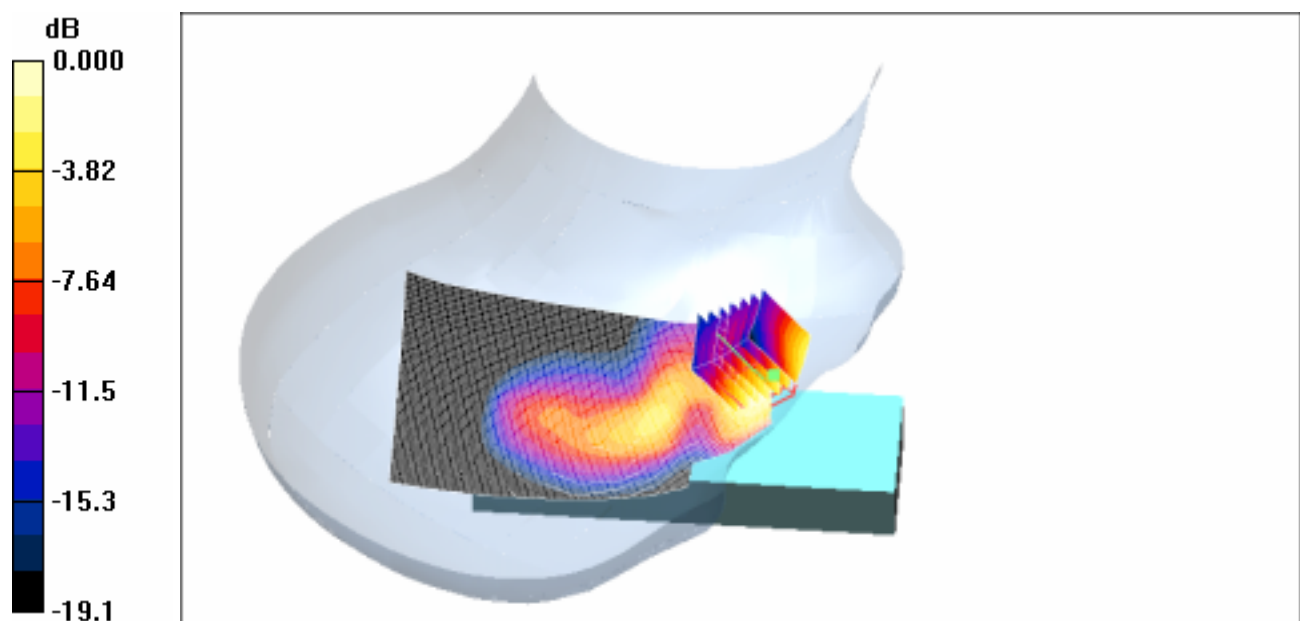

0 dB = 0.373mW/g

4.23RightHandSide-Cheek-PCS1900-Middle

Date/Time: 2006-7-10 16:33:12

Test Laboratory: SGS-GSM

FCC-OET65-RightHandSide-Cheek-PCS1900-Mid

DUT: GSM10006703M-Head; Type: Head; Serial: 01090000000322-7

Communication System: PCS1900-GSM Mode; Frequency: 1880 MHz; Duty Cycle: 1:8.3

Medium: HSL1900 Medium parameters used: $f = 1880$ MHz; $\sigma = 1.44$ mho/m; $\epsilon_r = 40.3$; $\rho = 1000$ kg/m³

Phantom section: Right Section

Measurement Standard: DASY4 (High Precision Assessment)

DASY4 Configuration:

- Probe: ES3DV3 - SN3088; ConvF(4.93, 4.93, 4.93); Calibrated: 2005-9-13
- Sensor-Surface: 4mm (Mechanical Surface Detection)
- Electronics: DAE3 Sn569; Calibrated: 2005-11-17
- Phantom: SAM 12; Type: SAM V4.0; Serial: TP-1283
- Measurement SW: DASY4, V4.6 Build 23; Postprocessing SW: SEMCAD, V1.8 Build 160

Cheek position - Middle/Area Scan (61x101x1): Measurement grid: dx=15mm, dy=15mm

Maximum value of SAR (interpolated) = 0.401 mW/g

Cheek position - Middle/Zoom Scan (7x7x7)/Cube 0: Measurement grid: dx=5mm, dy=5mm, dz=5mm

Reference Value = 5.21 V/m; Power Drift = -0.310 dB

Peak SAR (extrapolated) = 0.551 W/kg

SAR(1 g) = 0.365 mW/g; SAR(10 g) = 0.217 mW/g

Maximum value of SAR (measured) = 0.399 mW/g

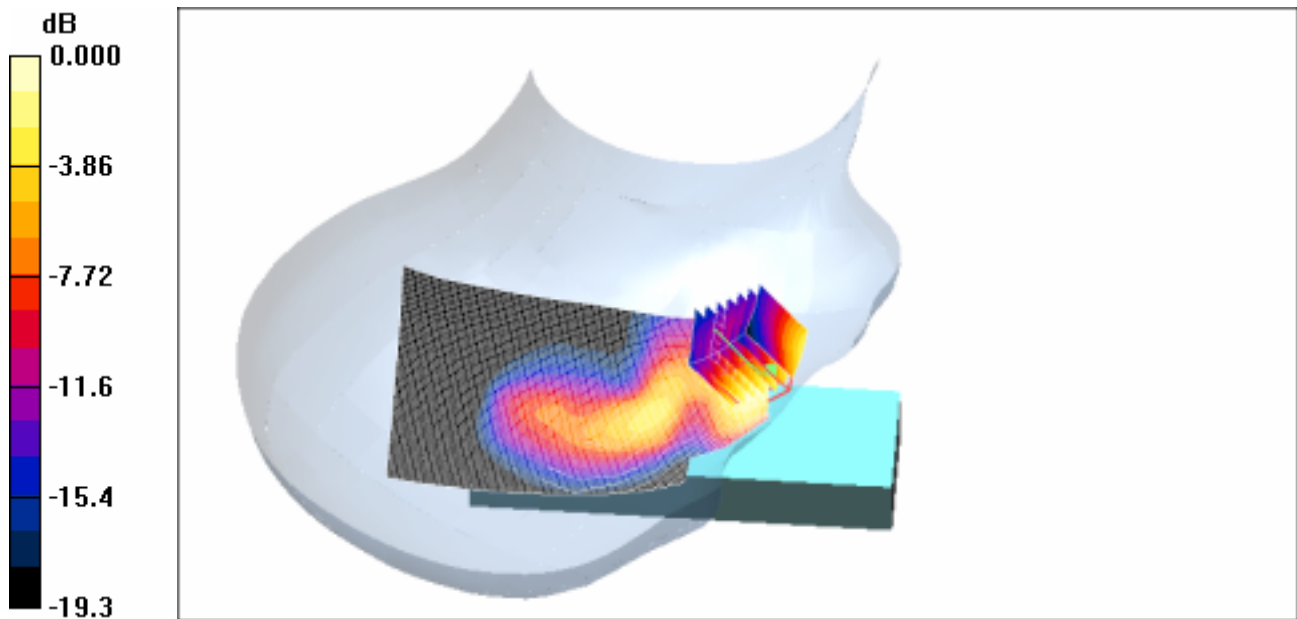

0 dB = 0.399mW/g

4.24RightHandSide-Cheek-PCS1900-High

Date/Time: 2006-7-10 17:05:40

Test Laboratory: SGS-GSM

FCC-OET65-RightHandSide-Cheek-PCS1900-High

DUT: GSM10006703M-Head; Type: Head; Serial: 01090000000322-7

Communication System: PCS1900-GSM Mode; Frequency: 1909.8 MHz; Duty Cycle: 1:8.3

Medium: HSL1900 Medium parameters used: $f = 1909.8 \text{ MHz}$; $\sigma = 1.47 \text{ mho/m}$; $\epsilon_r = 40$; $\rho = 1000 \text{ kg/m}^3$

Phantom section: Right Section

Measurement Standard: DASY4 (High Precision Assessment)

DASY4 Configuration:

- Probe: ES3DV3 - SN3088; ConvF(4.93, 4.93, 4.93); Calibrated: 2005-9-13
- Sensor-Surface: 4mm (Mechanical Surface Detection)
- Electronics: DAE3 Sn569; Calibrated: 2005-11-17

- Phantom: SAM 12; Type: SAM V4.0; Serial: TP-1283
- Measurement SW: DASY4, V4.6 Build 23; Postprocessing SW: SEMCAD, V1.8 Build 160

Cheek position - High/Area Scan (61x101x1): Measurement grid: dx=15mm, dy=15mm

Maximum value of SAR (interpolated) = 0.356 mW/g

Cheek position - High/Zoom Scan (7x7x7) (7x7x7)/Cube 0: Measurement grid: dx=5mm, dy=5mm,

dz=5mm

Reference Value = 4.86 V/m; Power Drift = -0.148 dB

Peak SAR (extrapolated) = 0.508 W/kg

SAR(1 g) = 0.331 mW/g; SAR(10 g) = 0.195 mW/g

Maximum value of SAR (measured) = 0.363 mW/g

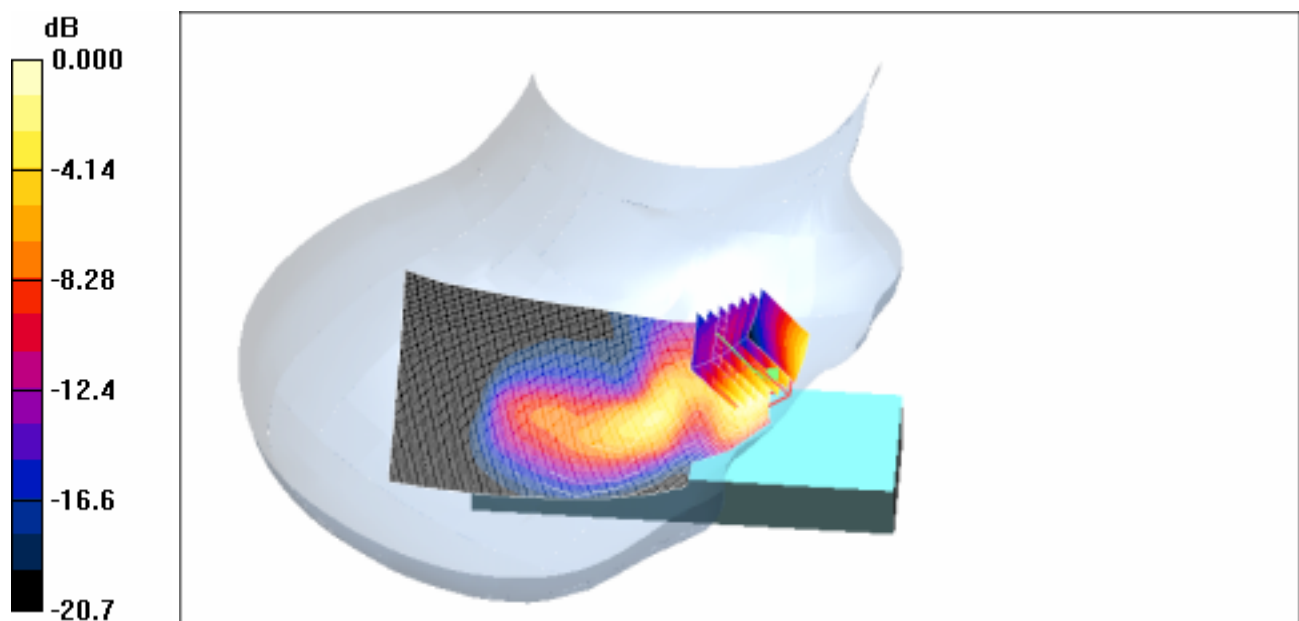

0 dB = 0.363mW/g

4.25RightHandSide-Tilt-PCS1900-Low

Date/Time: 2006-7-11 8:39:51

Test Laboratory: SGS-GSM

FCC-OET65-RightHandSide-Tilt-PCS1900-Low

DUT: GSM10006703M-Head; Type: Head; Serial: 01090000000322-7

Communication System: PCS1900-GSM Mode; Frequency: 1850.2 MHz; Duty Cycle: 1:8.3

Medium: HSL1900 Medium parameters used: $f = 1850.2$ MHz; $\sigma = 1.42$ mho/m; $r = 40.5$; $\rho = 1000$ kg/m³

Phantom section: Right Section

Measurement Standard: DASY4 (High Precision Assessment)

DASY4 Configuration:

- Probe: ES3DV3 - SN3088; ConvF(4.93, 4.93, 4.93); Calibrated: 2005-9-13
- Sensor-Surface: 4mm (Mechanical Surface Detection)
- Electronics: DAE3 Sn569; Calibrated: 2005-11-17
- Phantom: SAM 12; Type: SAM V4.0; Serial: TP-1283
- Measurement SW: DASY4, V4.6 Build 23; Postprocessing SW: SEMCAD, V1.8 Build 160

Tilt position - Low/Area Scan (71x111x1): Measurement grid: dx=15mm, dy=15mm

Maximum value of SAR (interpolated) = 0.087 mW/g

Tilt position - Low/Zoom Scan (7x7x7) (7x7x7)/Cube 0: Measurement grid: dx=5mm, dy=5mm, dz=5mm

Reference Value = 7.05 V/m; Power Drift = -0.097 dB

Peak SAR (extrapolated) = 0.116 W/kg

SAR(1 g) = 0.072 mW/g; SAR(10 g) = 0.041 mW/g

Maximum value of SAR (measured) = 0.080 mW/g

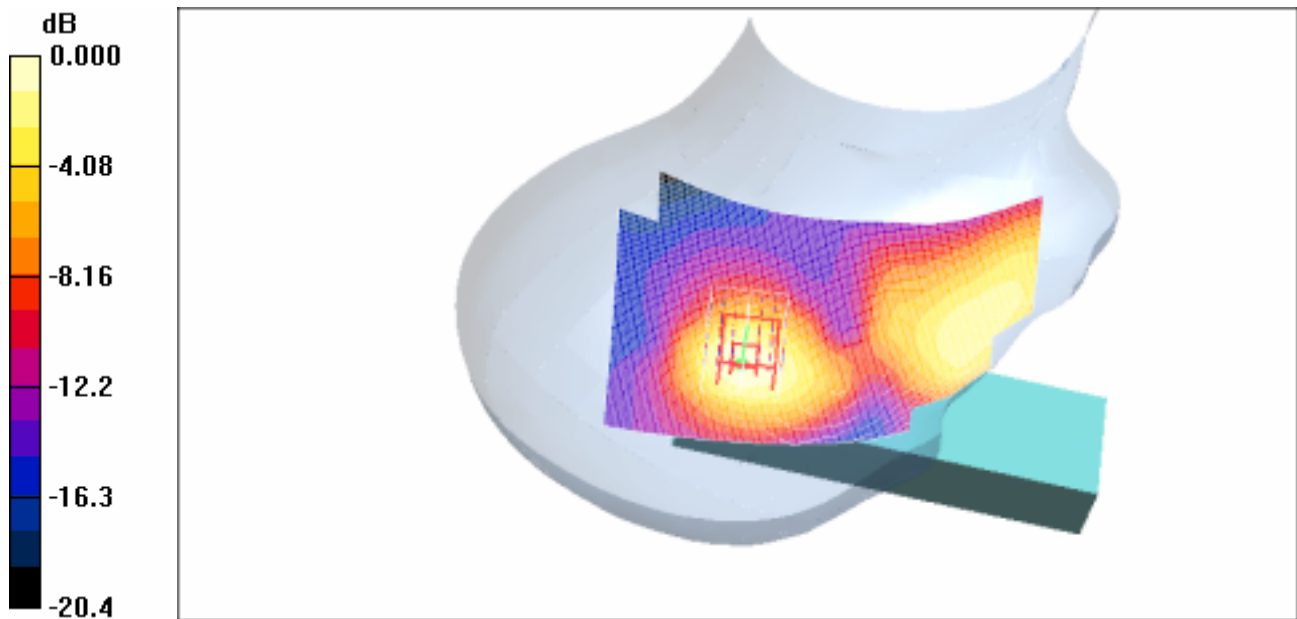

0 dB = 0.080mW/g

4.26RightHandSide-Tilt-PCS1900-Middle

Date/Time: 2006-7-11 9:18:29

Test Laboratory: SGS-GSM

FCC-OET65-RightHandSide-Tilt-PCS1900-Mid

DUT: GSM10006703M-Head; Type: Head; Serial: 01090000000322-7

Communication System: PCS1900-GSM Mode; Frequency: 1880 MHz;Duty Cycle: 1:8.3

Medium: HSL1900 Medium parameters used: $f = 1880 \text{ MHz}$; $\sigma = 1.44 \text{ mho/m}$; $\epsilon_r = 40.3$; $\rho = 1000 \text{ kg/m}^3$

Phantom section: Right Section

Measurement Standard: DASY4 (High Precision Assessment)

DASY4 Configuration:

- Probe: ES3DV3 - SN3088; ConvF(4.93, 4.93, 4.93); Calibrated: 2005-9-13
- Sensor-Surface: 4mm (Mechanical Surface Detection)
- Electronics: DAE3 Sn569; Calibrated: 2005-11-17

- Phantom: SAM 12; Type: SAM V4.0; Serial: TP-1283
- Measurement SW: DASY4, V4.6 Build 23; Postprocessing SW: SEMCAD, V1.8 Build 160

Tilt position - Middle/Area Scan (71x111x1): Measurement grid: dx=15mm, dy=15mm

Maximum value of SAR (interpolated) = 0.076 mW/g

Tilt position - Middle/Zoom Scan (7x7x7)/Cube 0: Measurement grid: dx=5mm, dy=5mm, dz=5mm

Reference Value = 6.55 V/m; Power Drift = -0.054 dB

Peak SAR (extrapolated) = 0.104 W/kg

SAR(1 g) = 0.064 mW/g; SAR(10 g) = 0.036 mW/g

Maximum value of SAR (measured) = 0.071 mW/g

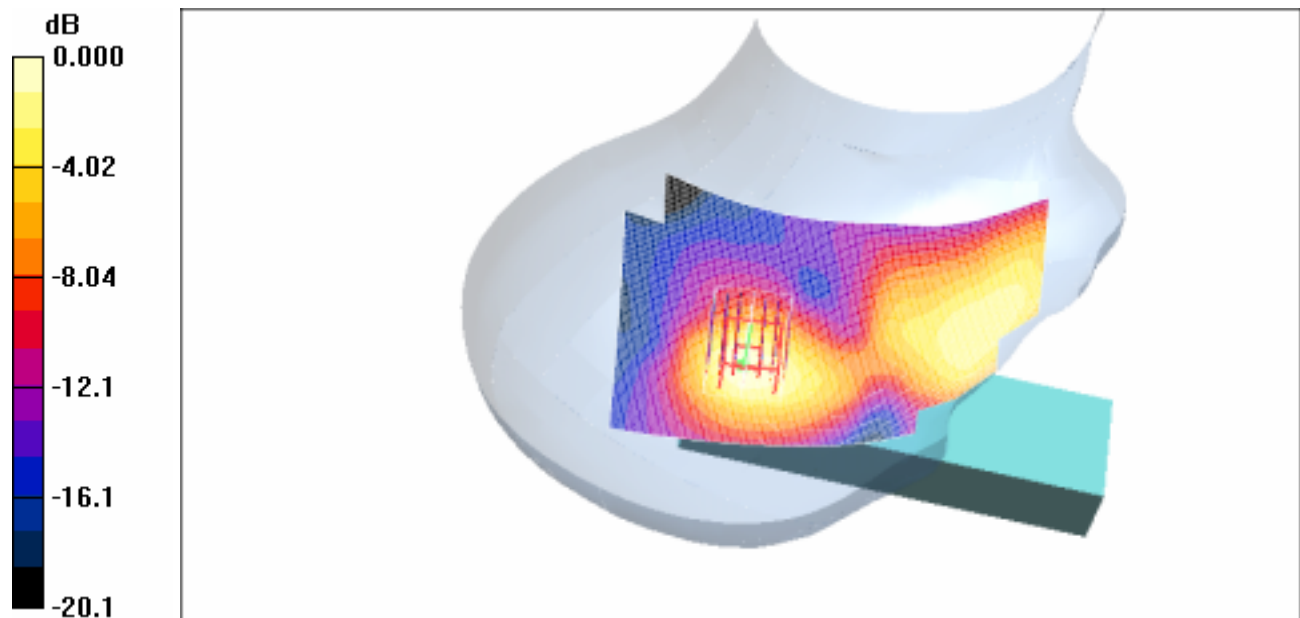

0 dB = 0.071mW/g

4.27RightHandSide-Tilt-PCS1900-High

Date/Time: 2006-7-11 9:51:45

Test Laboratory: SGS-GSM

FCC-OET65-RightHandSide-Tilt-PCS1900-High

DUT: GSM10006703M-Head; Type: Head; Serial: 01090000000322-7

Communication System: PCS1900-GSM Mode; Frequency: 1909.8 MHz; Duty Cycle: 1:8.3

Medium: HSL1900 Medium parameters used: $f = 1909.8 \text{ MHz}$; $\sigma = 1.47 \text{ mho/m}$; $r = 40$; $\rho = 1000 \text{ kg/m}^3$

Phantom section: Right Section

Measurement Standard: DAS4 (High Precision Assessment)

DASY4 Configuration:

- Probe: ES3DV3 - SN3088; ConvF(4.93, 4.93, 4.93); Calibrated: 2005-9-13
- Sensor-Surface: 4mm (Mechanical Surface Detection)
- Electronics: DAE3 Sn569; Calibrated: 2005-11-17
- Phantom: SAM 12; Type: SAM V4.0; Serial: TP-1283
- Measurement SW: DAS4, V4.6 Build 23; Postprocessing SW: SEMCAD, V1.8 Build 160

Tilt position - High/Area Scan (71x111x1): Measurement grid: $dx=15\text{mm}$, $dy=15\text{mm}$

Maximum value of SAR (interpolated) = 0.060 mW/g

Tilt position - High/Zoom Scan (7x7x7) (7x7x7)/Cube 0: Measurement grid: $dx=5\text{mm}$, $dy=5\text{mm}$, $dz=5\text{mm}$

Reference Value = 5.73 V/m; Power Drift = -0.063 dB

Peak SAR (extrapolated) = 0.084 W/kg

SAR(1 g) = 0.051 mW/g; SAR(10 g) = 0.028 mW/g

Maximum value of SAR (measured) = 0.057 mW/g

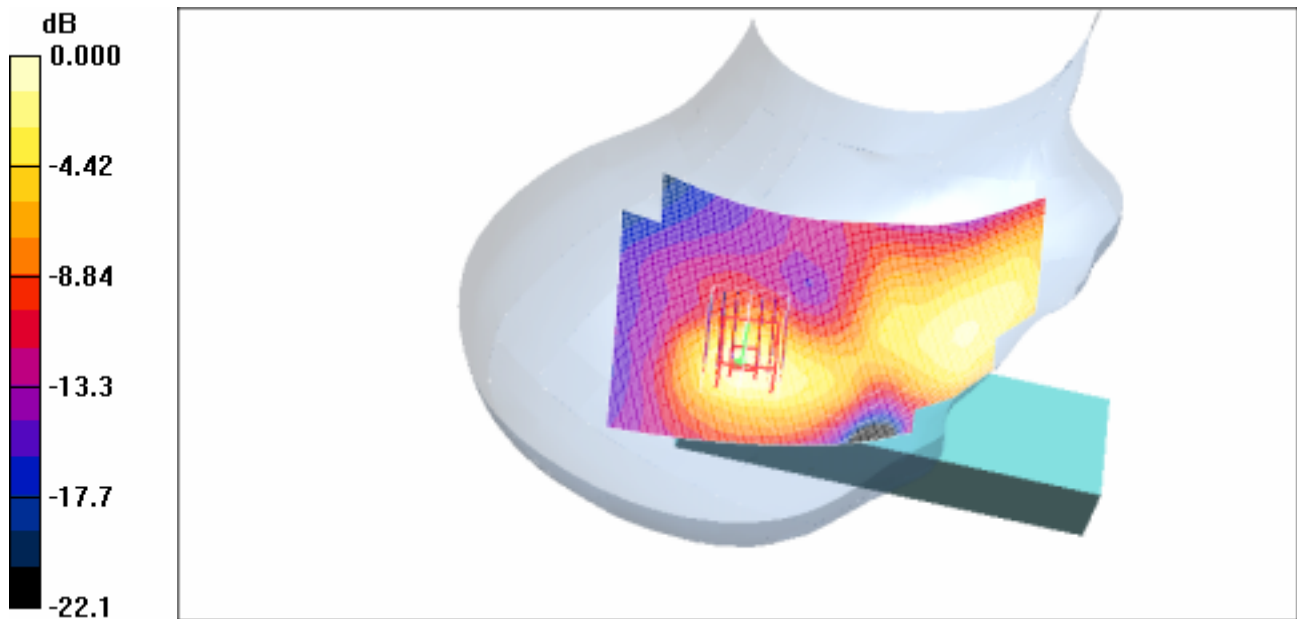

0 dB = 0.057mW/g

4.28Body-Worn-PCS1900-GPRS-Low

Date/Time: 2006-7-13 9:02:42

Test Laboratory: SGS-GSM

FCC-OET65-Body-Worn-PCS1900-GPRS-Low-2cm

DUT: GSM10006703M-Body; Type: Body; Serial: 01090000000322-7

Communication System: PCS1900-GPRS Mode; Frequency: 1850.2 MHz; Duty Cycle: 1:4

Medium: HSL1900-Body Medium parameters used: $f = 1850.2 \text{ MHz}$; $\sigma = 1.49 \text{ mho/m}$; $\epsilon_r = 51.6$; $\rho = 1000 \text{ kg/m}^3$

Phantom section: Flat Section

Measurement Standard: DASY4 (High Precision Assessment)

DASY4 Configuration:

- Probe: ES3DV3 - SN3088; ConvF(4.53, 4.53, 4.53); Calibrated: 2005-9-13
- Sensor-Surface: 4mm (Mechanical Surface Detection)
- Electronics: DAE3 Sn569; Calibrated: 2005-11-17

- Phantom: SAM 12; Type: SAM V4.0; Serial: TP-1283
- Measurement SW: DASY4, V4.6 Build 23; Postprocessing SW: SEMCAD, V1.8 Build 160

Body Worn - Low/Area Scan (51x91x1): Measurement grid: dx=15mm, dy=15mm

Maximum value of SAR (interpolated) = 0.788 mW/g

Body Worn - Low/Zoom Scan (7x7x7) (7x7x7)/Cube 0: Measurement grid: dx=5mm, dy=5mm, dz=5mm

Reference Value = 13.8 V/m; Power Drift = -0.176 dB

Peak SAR (extrapolated) = 1.14 W/kg

SAR(1 g) = 0.721 mW/g; SAR(10 g) = 0.438 mW/g

Maximum value of SAR (measured) = 0.779 mW/g

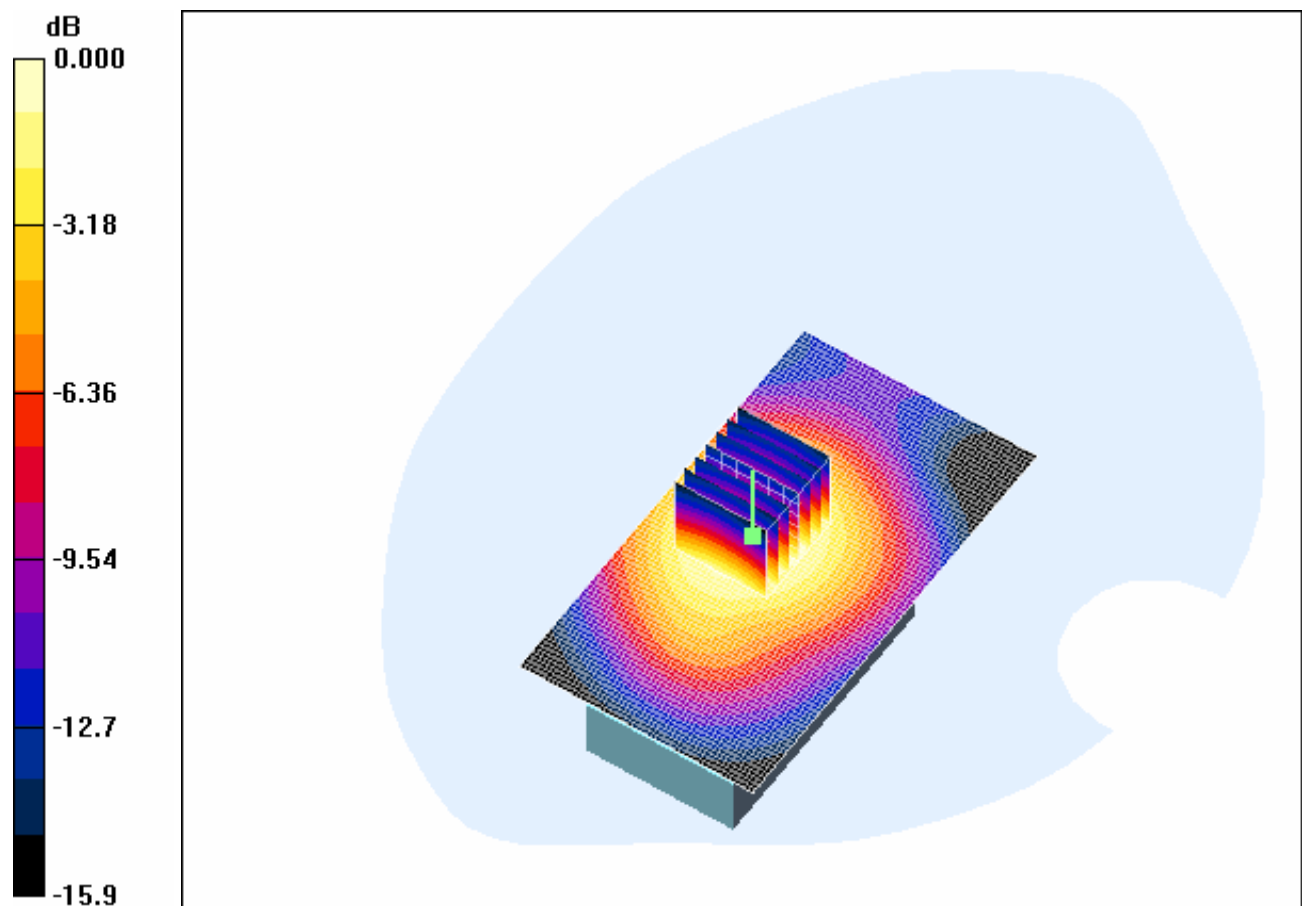

0 dB = 0.779mW/g

4.29 Body-Worn-PCS1900-GPRS-Middle

Date/Time: 2006-7-13 10:05:42

Test Laboratory: SGS-GSM

FCC-OET65-Body-Worn-PCS1900-GPRS-Mid-2cm

DUT: GSM10006703M-Body; Type: Body; Serial: 01090000000322-7

Communication System: PCS1900-GPRS Mode; Frequency: 1880 MHz; Duty Cycle: 1:4

Medium: HSL1900-Body Medium parameters used: $f = 1880 \text{ MHz}$; $\sigma = 1.52 \text{ mho/m}$; $\rho = 51.5$; $\rho = 1000 \text{ kg/m}^3$

Phantom section: Flat Section

Measurement Standard: DASYS4 (High Precision Assessment)

DASY4 Configuration:

- Probe: ES3DV3 - SN3088; ConvF(4.53, 4.53, 4.53); Calibrated: 2005-9-13
- Sensor-Surface: 4mm (Mechanical Surface Detection)
- Electronics: DAE3 Sn569; Calibrated: 2005-11-17
- Phantom: SAM 12; Type: SAM V4.0; Serial: TP-1283
- Measurement SW: DASYS4, V4.6 Build 23; Postprocessing SW: SEMCAD, V1.8 Build 160

Body Worn - Middle/Area Scan (51x91x1): Measurement grid: $dx=15\text{mm}$, $dy=15\text{mm}$

Maximum value of SAR (interpolated) = 0.722 mW/g

Body Worn - Middle/Zoom Scan (7x7x7)/Cube 0: Measurement grid: $dx=5\text{mm}$, $dy=5\text{mm}$, $dz=5\text{mm}$

Reference Value = 14.0 V/m; Power Drift = -0.143 dB

Peak SAR (extrapolated) = 1.04 W/kg

SAR(1 g) = 0.654 mW/g; SAR(10 g) = 0.394 mW/g

Maximum value of SAR (measured) = 0.712 mW/g

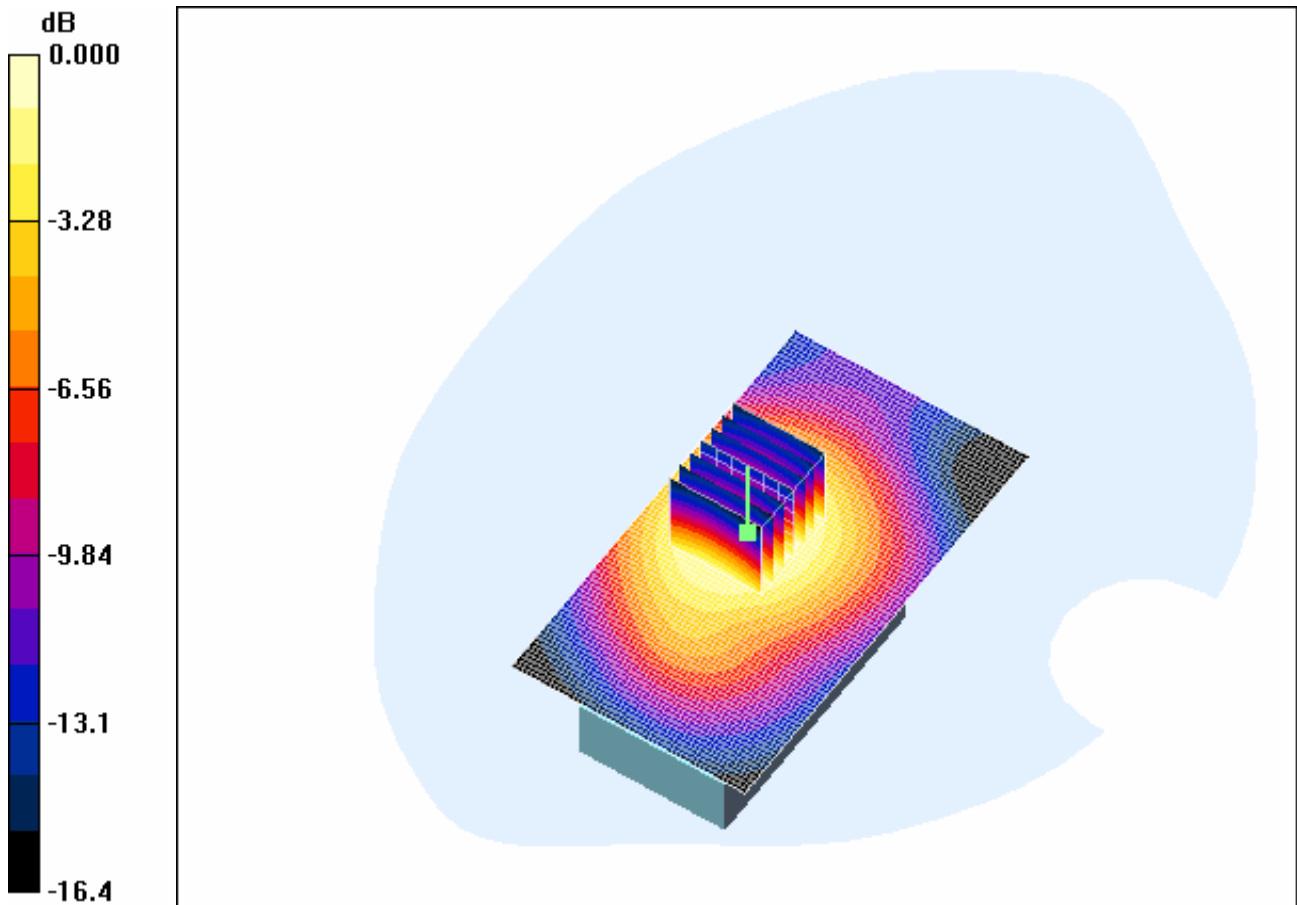

0 dB = 0.712mW/g

4.30Body-Worn-PCS1900-GPRS-High

Date/Time: 2006-7-13 10:30:39

Test Laboratory: SGS-GSM

FCC-OET65-Body-Worn-PCS1900-GPRS-High-2cm

DUT: GSM10006703M-Body; Type: Body; Serial: 01090000000322-7

Communication System: PCS1900-GPRS Mode; Frequency: 1909.8 MHz; Duty Cycle: 1:4

Medium: HSL1900-Body Medium parameters used: $f = 1909.8 \text{ MHz}$; $\sigma = 1.55 \text{ mho/m}$; $\epsilon_r = 51.5$; $\rho = 1000 \text{ kg/m}^3$

Phantom section: Flat Section

Measurement Standard: DASY4 (High Precision Assessment)

DASY4 Configuration:

- Probe: ES3DV3 - SN3088; ConvF(4.53, 4.53, 4.53); Calibrated: 2005-9-13
- Sensor-Surface: 4mm (Mechanical Surface Detection)
- Electronics: DAE3 Sn569; Calibrated: 2005-11-17
- Phantom: SAM 12; Type: SAM V4.0; Serial: TP-1283
- Measurement SW: DASY4, V4.6 Build 23; Postprocessing SW: SEMCAD, V1.8 Build 160

Body Worn - High/Area Scan (51x91x1): Measurement grid: dx=15mm, dy=15mm

Maximum value of SAR (interpolated) = 0.578 mW/g

Body Worn - High/Zoom Scan (7x7x7) (7x7x7)/Cube 0: Measurement grid: dx=5mm, dy=5mm, dz=5mm

Reference Value = 12.9 V/m; Power Drift = -0.008 dB

Peak SAR (extrapolated) = 0.852 W/kg

SAR(1 g) = 0.532 mW/g; SAR(10 g) = 0.319 mW/g

Maximum value of SAR (measured) = 0.578 mW/g

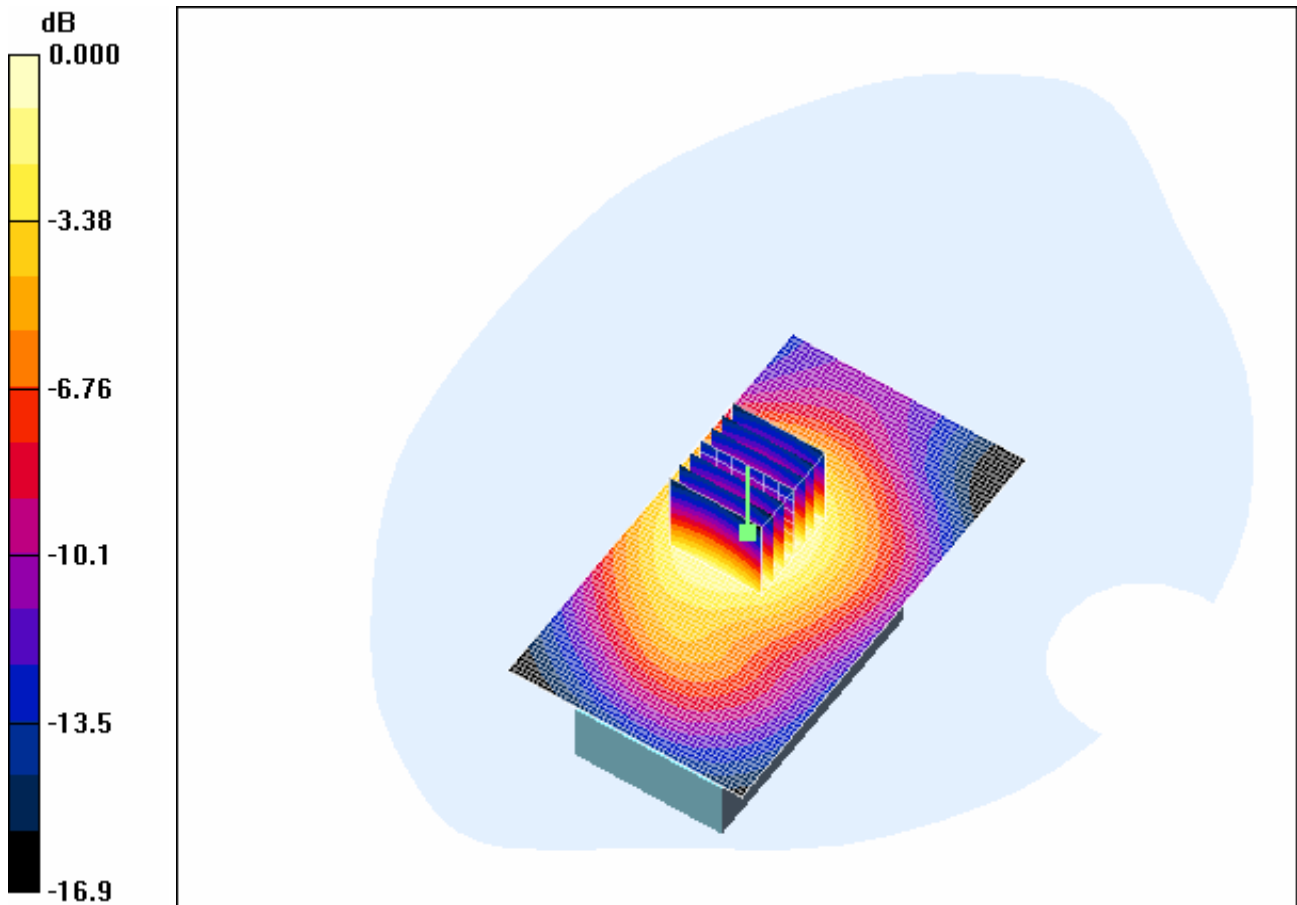

0 dB = 0.578mW/g

Appendix

1. Photographs of Test Setup

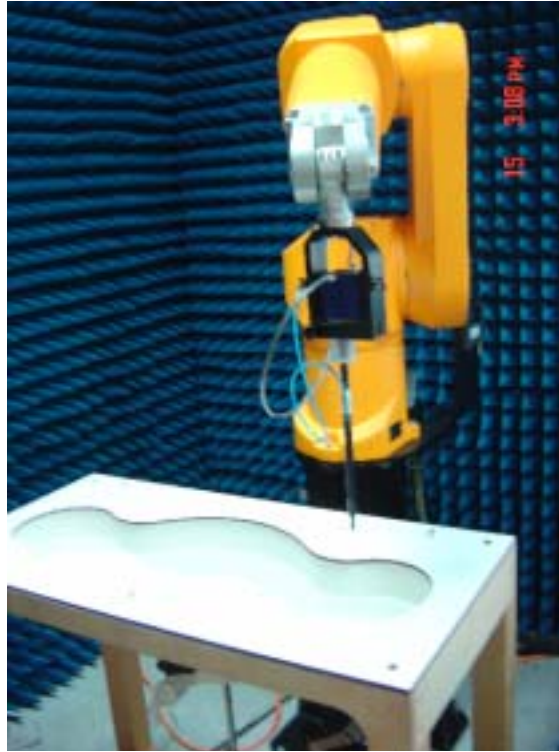

Fig.1 Photograph of the SAR measurement System

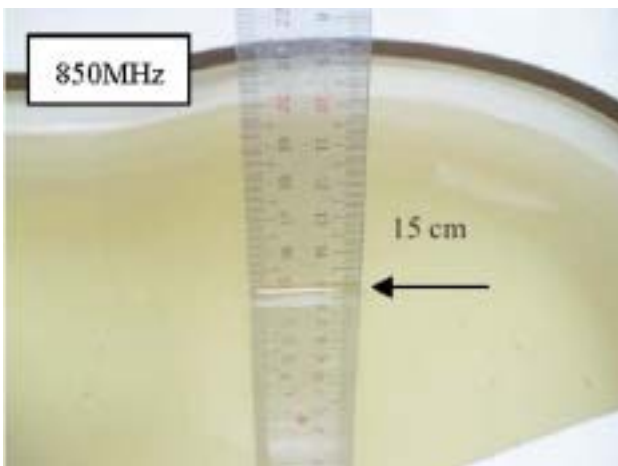

Fig.2 Photograph of the Tissue Simulant Fluid Liquid depth 15cm for Left-Head Side

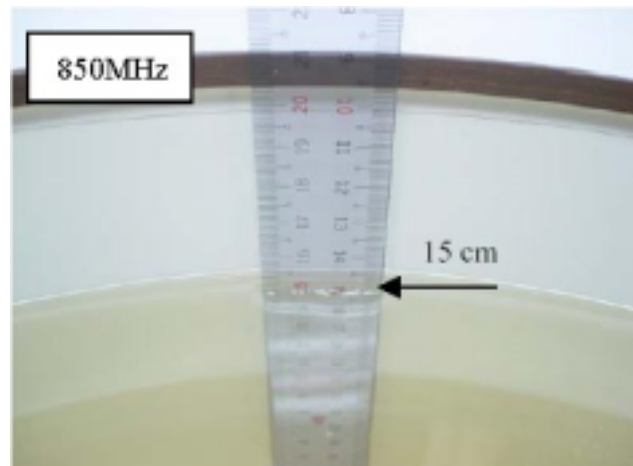

Fig.3 Photograph of the Tissue Simulant Liquid depth 15cm for Body-Worn

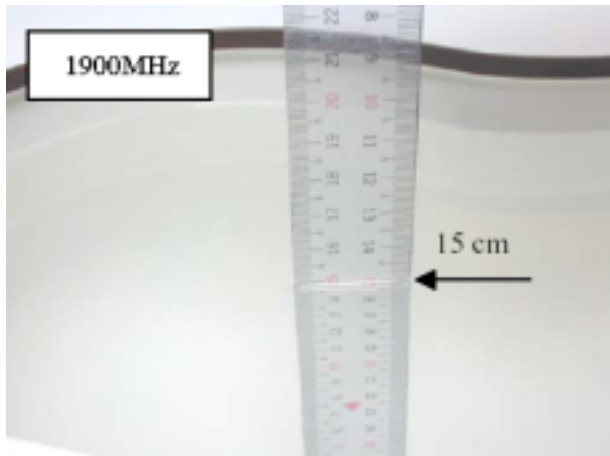

Fig.4 Photograph of the Tissue Simulant Fluid Liquid depth 15cm for Right-Head Side

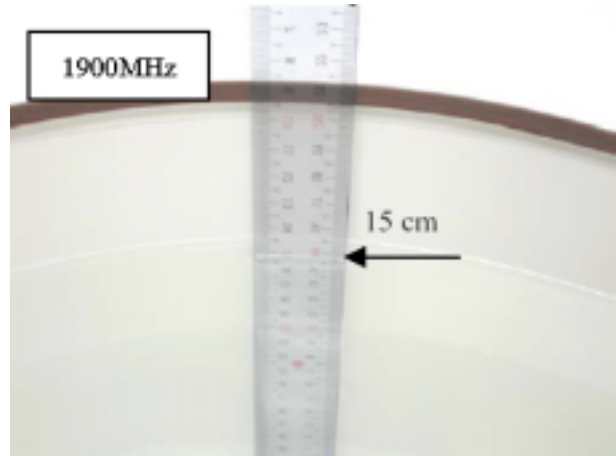

Fig.5 Photograph of the Tissue Simulant Liquid depth 15cm for Body-Worn



Fig.6 Photograph of the Left Hand Side Cheek status



Fig.7 Photograph of the Left Hand Side Tilt status

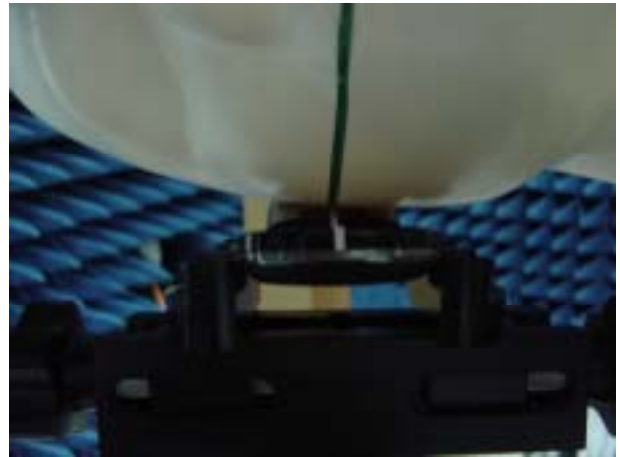

Fig.8 Photograph of the Right Hand Side Cheek status



Fig.9 Photograph of the Right Hand Side Tilt status



Fig.10 Photograph of the BodyWorn status

2. Photographs of the EUT



Fig.11 Front View





Fig.12 Back View

3. Photographs of the battery

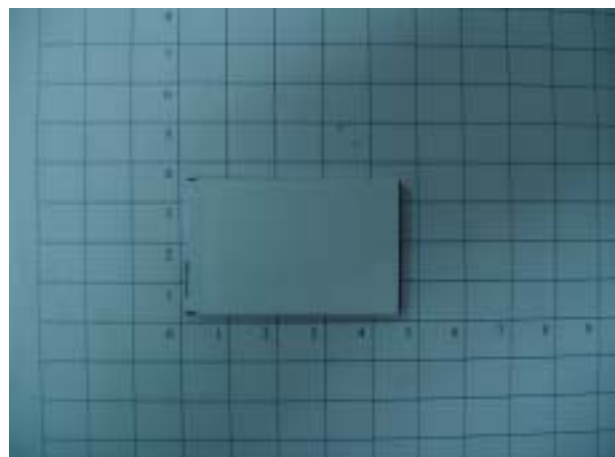

Fig.13 Front view of battery

Fig.14 Back view of battery

4. Photograph of the charger



Fig.15 Charger

5. Probe Calibration certificate

Calibration Laboratory of
Schmid & Partner
Engineering AG
Zeughausstrasse 43, 8004 Zurich, Switzerland



S Schweizerischer Kalibrierdienst
S Service suisse d'étalonnage
C Servizio svizzero di taratura
S Swiss Calibration Service

Accredited by the Swiss Federal Office of Metrology and Accreditation
The Swiss Accreditation Service is one of the signatories to the EA
Multilateral Agreement for the recognition of calibration certificates

Accreditation No.: SCS 108

Client: SGS-CSTX (MTT)

Certificate No: ES3-3088_Sep05

CALIBRATION CERTIFICATE

Object: ES3DV3 - SN.3088

Calibration procedure(s):
QA CAL-01.v5
Calibration procedure for dosimetric E-field probes

Calibration date: September 13, 2005

Condition of the calibrated item: In Tolerance

This calibration certificate documents the traceability to national standards, which realize the physical units of measurements (SI).
The measurements and the uncertainties with confidence probability are given on the following pages and are part of the certificate.

All calibrations have been conducted in the closed laboratory facility; environment temperature ($22 \pm 3/^\circ\text{C}$) and humidity $< 75\%$.

Calibration Equipment used (M&TE critical for calibration)

Primary Standards	ID #	Cal Date (Calibrated by, Certificate No.)	Scheduled Calibration
Power meter E44198	0B41293874	3-May-05 (METAS, No. 251-00488)	May-06
Power sensor E4412A	MY41485277	3-May-05 (METAS, No. 251-00488)	May-06
Power sensor E4412A	MY41485087	3-May-05 (METAS, No. 251-00488)	May-06
Reference 3 dB Attenuator	SN: S5054 (30)	11-Aug-05 (METAS, No. 251-00499)	Aug-06
Reference 20 dB Attenuator	SN: S5066 (20b)	3-May-05 (METAS, No. 251-00487)	May-06
Reference 30 dB Attenuator	SN: S5129 (30b)	11-Aug-05 (METAS, No. 251-00500)	Aug-06
Reference Probe ES3DV2	SN: 3013	7-Jan-05 (SPEAG, No. ES3-3013_Jan05)	Jan-06
DAE4	SN: 654	29-Nov-04 (SPEAG, No. DAE4-654_Nov04)	Nov-05

Secondary Standards	ID #	Check Date (in house)	Scheduled Check
RF generator HP 8648C	US3262UD1700	4-Aug-05 (SPEAG, in house check Dec-03)	In house check: Dec-05
Network Analyzer HP 8733C	US37360585	18-Oct-01 (SPEAG, in house check Nov-04)	In house check: Nov-05

Calibrated by:	Name	Function	Signature
	Nico Vetterli	Laboratory Technician	
Approved by:	Kajsa Pokovic	Technical Manager	

Issued: September 15, 2005

This calibration certificate shall not be reproduced except in full without written approval of the laboratory.

Calibration Laboratory of
Schmid & Partner
Engineering AG
Zeughausstrasse 43, 8004 Zurich, Switzerland



S Schweizerischer Kalibrierdienst
C Service suisse d'étalonnage
S Servizio svizzero di taratura
S Swiss Calibration Service

Accredited by the Swiss Federal Office of Metrology and Accreditation
The Swiss Accreditation Service is one of the signatories to the EA
Multilateral Agreement for the recognition of calibration certificates

Accreditation No.: **SCS 108**

Glossary:

TSL	tissue simulating liquid
NORM _{x,y,z}	sensitivity in free space
ConF	sensitivity in TSL / NORM _{x,y,z}
DCP	diode compression point
Polarization φ	φ rotation around probe axis
Polarization θ	θ rotation around an axis that is in the plane normal to probe axis (at measurement center), i.e., $\theta = 0$ is normal to probe axis

Calibration is Performed According to the Following Standards:

- IEEE Std 1528-2003, "IEEE Recommended Practice for Determining the Peak Spatial-Averaged Specific Absorption Rate (SAR) in the Human Head from Wireless Communications Devices: Measurement Techniques", December 2003
- CENELEC EN 50361, "Basic standard for the measurement of Specific Absorption Rate related to human exposure to electromagnetic fields from mobile phones (300 MHz - 3 GHz), July 2001

Methods Applied and Interpretation of Parameters:

- NORM_{x,y,z}**: Assessed for E-field polarization $\theta = 0$ ($f \leq 900$ MHz in TEM-cell; $f > 1800$ MHz: R22 waveguide). NORM_{x,y,z} are only intermediate values, i.e., the uncertainties of NORM_{x,y,z} does not affect the E²-field uncertainty inside TSL (see below ConF).
- NORM(f)_{x,y,z} = NORM_{x,y,z} * frequency_response** (see Frequency Response Chart). This linearization is implemented in DASY4 software versions later than 4.2. The uncertainty of the frequency response is included in the stated uncertainty of ConF.
- DCP_{x,y,z}**: DCP are numerical linearization parameters assessed based on the data of power sweep (no uncertainty required). DCP does not depend on frequency nor media.
- ConF and Boundary Effect Parameters**: Assessed in flat phantom using E-field (or Temperature Transfer Standard for $f \leq 800$ MHz) and inside waveguide using analytical field distributions based on power measurements for $f > 800$ MHz. The same setups are used for assessment of the parameters applied for boundary compensation (alpha, depth) of which typical uncertainty values are given. These parameters are used in DASY4 software to improve probe accuracy close to the boundary. The sensitivity in TSL corresponds to NORM_{x,y,z} * ConF whereby the uncertainty corresponds to that given for ConF. A frequency dependent ConF is used in DASY version 4.4 and higher which allows extending the validity from ± 50 MHz to ± 100 MHz.
- Spherical Isotropy (3D deviation from isotropy)**: in a field of low gradients realized using a flat phantom exposed by a patch antenna.
- Sensor Offset**: The sensor offset corresponds to the offset of virtual measurement center from the probe tip (on probe axis). No tolerance required.

ES3DV3 SN:3088

September 13, 2005

Probe ES3DV3

SN:3088

Manufactured:	July 20, 2005
Calibrated:	September 13, 2005

Calibrated for DASY Systems

(Note: non-compatible with DASY2 system!)

ES3DV3 SN:3088

September 13, 2005

DASY - Parameters of Probe: ES3DV3 SN:3088**Sensitivity in Free Space^A****Diode Compression^B**

NormX	1.32 ± 10.1%	$\mu\text{V}/(\text{V}/\text{m})^2$	DCP X	95 mV
NormY	1.24 ± 10.1%	$\mu\text{V}/(\text{V}/\text{m})^2$	DCP Y	95 mV
NormZ	1.23 ± 10.1%	$\mu\text{V}/(\text{V}/\text{m})^2$	DCP Z	95 mV

Sensitivity in Tissue Simulating Liquid (Conversion Factors)

Please see Page 8.

Boundary Effect**TSL 900 MHz Typical SAR gradient: 5 % per mm**

Sensor Center to Phantom Surface Distance		3.0 mm	4.0 mm
SAR ₉₅ [%]	Without Correction Algorithm	5.8	2.7
SAR ₉₅ [%]	With Correction Algorithm	0.0	0.1

TSL 1750 MHz Typical SAR gradient: 10 % per mm

Sensor Center to Phantom Surface Distance		3.0 mm	4.0 mm
SAR ₉₅ [%]	Without Correction Algorithm	7.6	4.5
SAR ₉₅ [%]	With Correction Algorithm	0.1	0.2

Sensor OffsetProbe Tip to Sensor Center **2.0 mm**

The reported uncertainty of measurement is stated as the standard uncertainty of measurement multiplied by the coverage factor k=2, which for a normal distribution corresponds to a coverage probability of approximately 95%.

^A The uncertainties of NormX,Y,Z do not affect the E²-field uncertainty inside TSL (see Page 8).

^B Numerical linearization parameter: uncertainty not required.

ES3DV3 SN:3088

September 13, 2005

Frequency Response of E-Field

(TEM-Cell:if1110 EXX, Waveguide: R22)

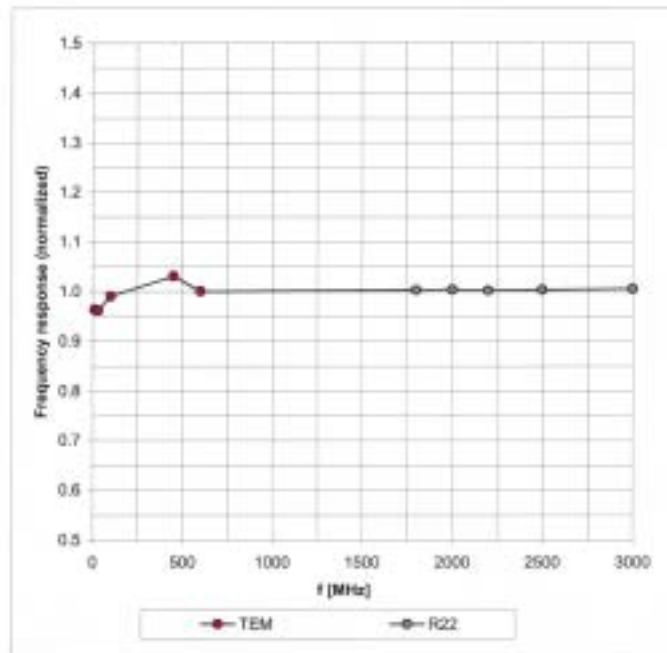

Uncertainty of Frequency Response of E-field: $\pm 6.3\%$ (k=2)

E53DV3 SN:3088

September 13, 2005

Receiving Pattern (ϕ), $\theta = 0^\circ$

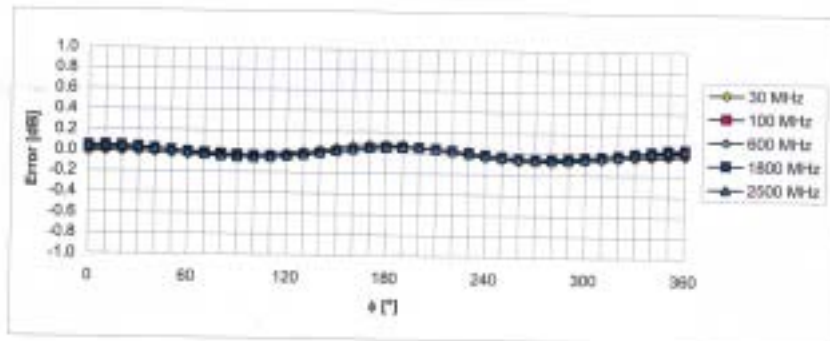
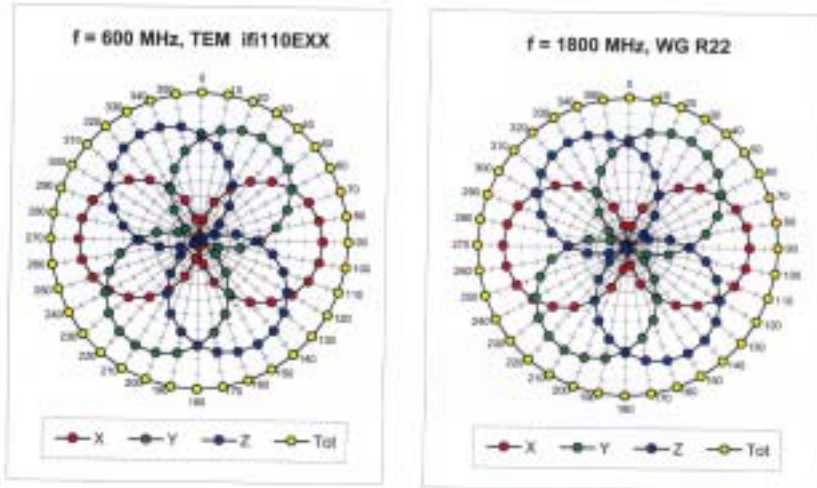

Uncertainty of Axial Isotropy Assessment: $\pm 0.5\%$ (k=2)

ES3DV3 SN:3088

September 13, 2005

Dynamic Range $f(SAR_{head})$ (Waveguide R22, $f = 1800$ MHz)

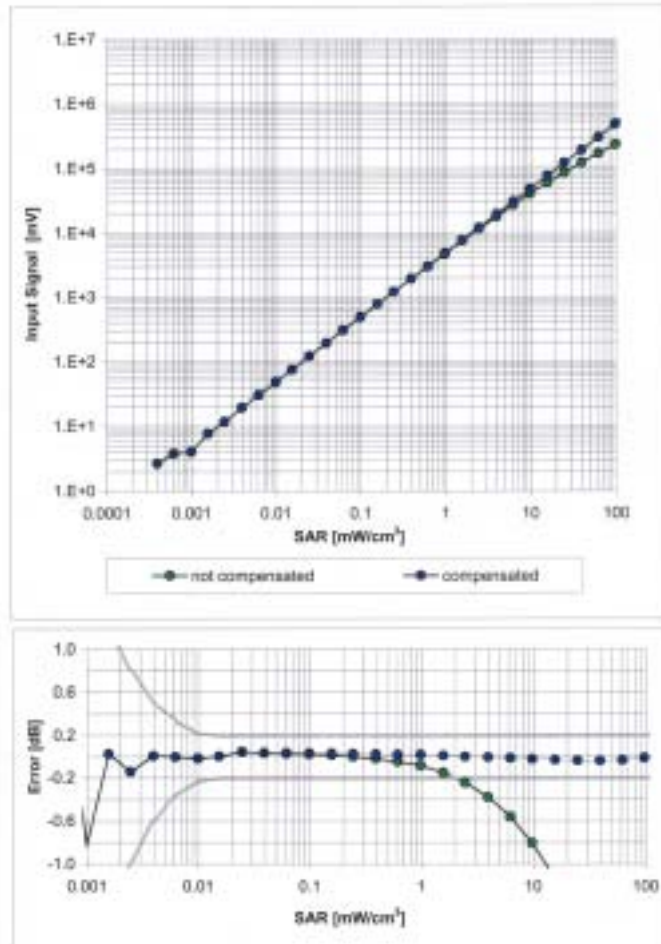

Uncertainty of Linearity Assessment: $\pm 0.6\%$ ($k=2$)

ES3DV3 SN:3088

September 13, 2005

Conversion Factor Assessment

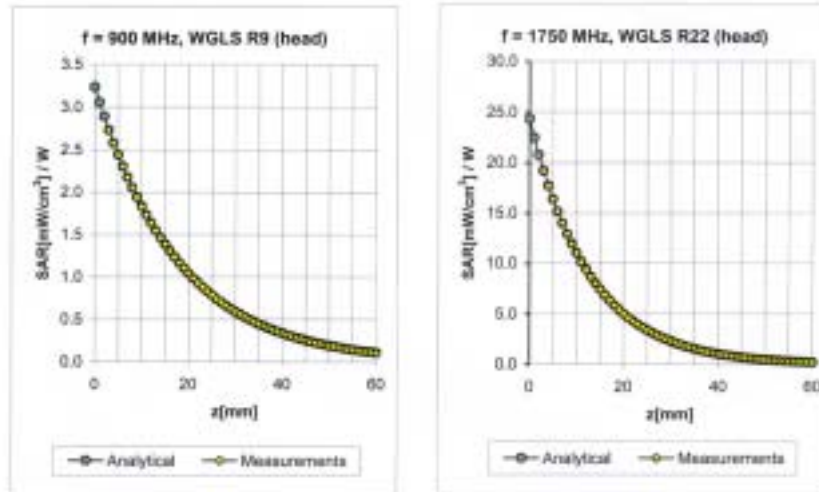

f [MHz]	Validity [MHz] ²	TSL	Permittivity	Conductivity	Alpha	Depth	ConvF	Uncertainty
900	± 50 / ± 100	Head	41.5 ± 5%	0.97 ± 5%	0.47	1.40	5.91 ± 11.0% (k=2)	
1750	± 50 / ± 100	Head	40.1 ± 5%	1.37 ± 5%	0.24	2.39	4.97 ± 11.0% (k=2)	
1900	± 50 / ± 100	Head	40.0 ± 5%	1.40 ± 5%	0.27	2.28	4.93 ± 11.0% (k=2)	
2000	± 50 / ± 100	Head	40.0 ± 5%	1.40 ± 5%	0.25	2.34	4.87 ± 11.0% (k=2)	
900	± 50 / ± 100	Body	55.0 ± 5%	1.05 ± 5%	0.61	1.25	5.83 ± 11.0% (k=2)	
1750	± 50 / ± 100	Body	53.4 ± 5%	1.49 ± 5%	0.28	2.53	4.61 ± 11.0% (k=2)	
1900	± 50 / ± 100	Body	53.3 ± 5%	1.52 ± 5%	0.28	2.57	4.53 ± 11.0% (k=2)	
2000	± 50 / ± 100	Body	53.3 ± 5%	1.52 ± 5%	0.32	2.11	4.47 ± 11.0% (k=2)	

² The validity of a 100 MHz only applies for DASY v4.4 and higher (see Page 2). The uncertainty is the RSS of the ConvF uncertainty at calibration frequency and the uncertainty for the indicated frequency band.

ES3DV3 SN:3088

September 13, 2005

Deviation from Isotropy in HSL

Error (ϕ , θ), $f = 900$ MHz

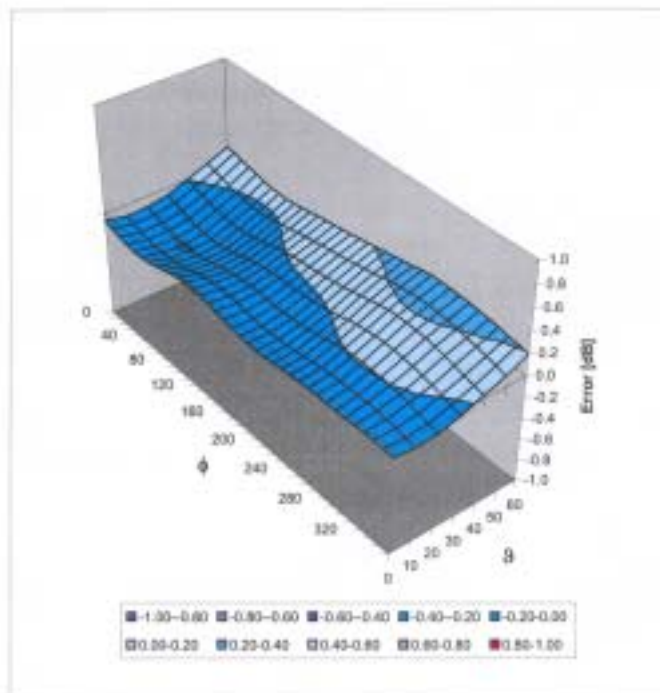

Uncertainty of Spherical Isotropy Assessment: $\pm 2.6\%$ ($k=2$)

6. Uncertainty analysis

Error Description	Tol. (± %)	Prob. dist.	Div.	(c_1) (1g)	(c_2) (10g)	Std. unc. (± %)		(v_i)
Std. unc. (1g)		Std. unc. (10g)						
Measurement System								
Probe Calibration	4.8	N	1	1	1	4.8	4.8	∞
Axial Isotropy	4.7	R	$\sqrt{3}$	1	1	2.7	2.7	∞
Hemispherical Isotropy	0	R	$\sqrt{3}$	1	1	0	0	∞
Boundary Effects	1.0	R	$\sqrt{3}$	1	1	0.6	0.6	∞
Linearity	4.7	R	$\sqrt{3}$	1	1	2.7	2.7	∞
System Detection Limit	1.0	R	$\sqrt{3}$	1	1	0.6	0.6	∞
Readout Electronics	1.0	N	1	1	1	1.0	1.0	∞
Response Time	0	R	$\sqrt{3}$	1	1	0	0	∞
Integration Time	0	R	$\sqrt{3}$	1	1	0	0	∞
RF Ambient Conditions	3.0	R	$\sqrt{3}$	1	1	1.7	1.7	∞
Probe Positioner	0.4	R	$\sqrt{3}$	1	1	0.2	0.2	∞
Probe Positioning	2.9	R	$\sqrt{3}$	1	1	1.7	1.7	∞
Algorithms for Max. SAR Eval.	1.0	R	$\sqrt{3}$	1	1	0.6	0.6	∞
Dipole								
Dipole Axis to Liquid Distance	2.0	R	$\sqrt{3}$	1	1	1.2	1.2	∞
Input power and SAR drift meas.	4.7	R	$\sqrt{3}$	1	1	2.7	2.7	∞
Phantom and Tissue Param.								
Phantom Uncertainty	4.0	R	$\sqrt{3}$	1	1	2.3	2.3	∞
Liquid Conductivity (target)	5.0	R.	$\sqrt{3}$	0.64	0.43	1.8	1.2	∞
Liquid Conductivity (meas.)	2.5	N	1	0.64	0.43	1.6	1.1	∞
Liquid Permittivity (target)	5.0	R	$\sqrt{3}$	0.6	0.49	1.7	1.4	∞
Liquid Permittivity (meas.)	2.5	N	1	0.6	0.49	1.5	1.2	∞
Combined Standard Uncertainty						8.4	8.1	∞
Coverage Factor for 95%		kp=2						
Expanded Uncertainty						16.8	16.2	

Dasy4 Uncertainty Budget

7. Phantom description

Schmid & Partner Engineering AG

Zeughausstrasse 43, 8004 Zurich, Switzerland, Phone +41 1 245 97 00, Fax +41 1 245 97 79

Certificate of conformity / First Article Inspection

Item	SAM Twin Phantom V4.0
Type No	QD 000 P40 CA
Series No	TP-1150 and higher
Manufacturer / Origin	Unterseer Composites Hauptstr. 69 CH-8559 Fruttwilen Switzerland

Tests

The series production process used allows the limitation to test of first articles. Complete tests were made on the pre-series Type No. QD 000 P40 AA, Serial No. TP-1001 and on the series first article Type No. QD 000 P40 BA, Serial No. TP-1006. Certain parameters have been retested using further series units (called samples).

Test	Requirement	Details	Units tested
Shape	Compliance with the geometry according to the CAD model.	ITIS CAD File (*)	First article, Samples
Material thickness	Compliant with the requirements according to the standards	2mm +/- 0.2mm in specific areas	First article, Samples
Material parameters	Dielectric parameters for required frequencies	200 MHz - 3 GHz Relative permittivity < 5 Loss tangent < 0.05	Material sample TP-104-5
Material resistivity	The material has been tested to be compatible with the liquids defined in the standards	Liquid type HSL 1800 and others according to the standard.	Pre-series, First article

Standards

- [1] CENELEC EN 50361
- [2] IEEE P1528-200x draft 6.5
- [3] IEC PT 62209 draft 0.9
- (*) The ITIS CAD file is derived from [2] and is also within the tolerance requirements of the shapes of [1] and [3].

Conformity

Based on the sample tests above, we certify that this item is in compliance with the uncertainty requirements of SAR measurements specified in standard [1] and draft standards [2] and [3].

Date

28.02.2002

Signature / Stamp

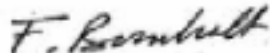

**Schmid & Partner
Engineering AG**

Zeughausstrasse 43, CH-8004 Zurich
Tel. +41 1 245 97 00, Fax +41 1 245 97 79

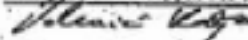

8. System validation from original equipment supplier**DASY4 Validation Report for Head TSL**

Date/Time: 19.08.2005 14:48:37

Test Laboratory: SPEAG, Zurich, Switzerland

DUT: Dipole 900 MHz; Type: D900V2; Serial: D900V2 - SN:184

Communication System: CW-900; Frequency: 900 MHz; Duty Cycle: 1:1

Medium: HSL 900 MHz;

Medium parameters used: $f = 900$ MHz; $\sigma = 0.96$ mho/m; $\epsilon_r = 42.1$; $\rho = 1000$ kg/m³

Phantom section: Flat Section

Measurement Standard: DASY4 (High Precision Assessment)

DASY4 Configuration:

- Probe: ET3DV6 - SN1507; CoaxF(5.95, 5.95, 5.95); Calibrated: 26.10.2004
- Sensor-Surface: 4mm (Mechanical Surface Detection)
- Electronics: DAE4 Set601; Calibrated: 07.01.2005
- Phantom: Flat Phantom 4.9L; Type: QD000P49AA
- Measurement SW: DASY4, V4.6 Build 9; Postprocessing SW: SEMCAD, V1.8 Build 151

Pin = 250 mW; d = 15 mm/Area Scan (81x81x1):Measurement grid: $dx=15$ mm, $dy=15$ mm

Maximum value of SAR (interpolated) = 2.81 mW/g

Pin = 250 mW; d = 15 mm/Zoom Scan 2 (7x7x7)/Cube 0:Measurement grid: $dx=5$ mm, $dy=5$ mm, $dz=5$ mm

Reference Value = 56.9 V/m; Power Drift = -0.018 dB

Peak SAR (extrapolated) = 3.84 W/kg

SAR(1 g) = 2.6 mW/g; SAR(10 g) = 1.67 mW/g

Maximum value of SAR (measured) = 2.82 mW/g

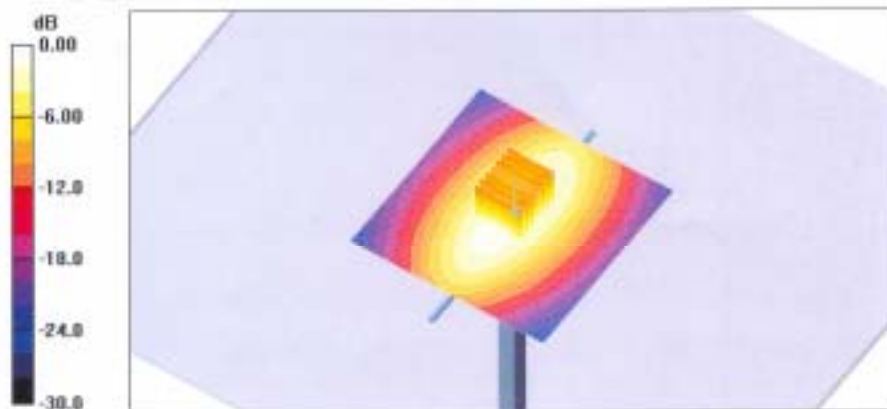

0 dB = 2.82mW/g

DASY4 Validation Report for Body TSL

Date/Time: 22.08.2005 16:14:01

Test Laboratory: SPEAG, Zurich, Switzerland

DUT: Dipole 900 MHz; Type: D900V2; Serial: D900V2 - SN:184

Communication System: CW-900; Frequency: 900 MHz; Duty Cycle: 1:1

Medium: MSL 900 MHz;

Medium parameters used: $f = 900$ MHz; $\sigma = 1.07$ mho/m; $\epsilon_r = 54.6$; $\rho = 1000$ kg/m³

Phantom section: Flat Section

Measurement Standard: DASY4 (High Precision Assessment)

DASY4 Configuration:

- Probe: ET3DVA8 - SN1307; Const(5.77, 5.77, 5.77); Calibrated: 26.10.2004
- Sensor-Surface: 4mm (Mechanical Surface Detection)
- Electronics: DA64 S0601; Calibrated: 07.01.2005
- Phantom: Flat Phantom 4.9L; Type: QD00P49AA
- Measurement SW: DASY4, V4.6 Build 9; Postprocessing SW: SEMCAD, V1.8 Build 151

Pin = 250 mW; d = 15 mm 2/Area Scan (81x81x1):

Measurement grid: dx=15mm, dy=15mm

Maximum value of SAR (interpolated) = 2.94 mW/g

Pin = 250 mW; d = 15 mm 2/Zoom Scan (7x7x7)/Cube 0:

Measurement grid: dx=5mm, dy=5mm, dz=5mm

Reference Value = 55.3 V/m; Power Drift = -0.00 dB

Peak SAR (extrapolated) = 3.90 W/kg

SAR(1 g) = 2.69 mW/g; SAR(10 g) = 1.74 mW/g

Maximum value of SAR (measured) = 2.96 mW/g

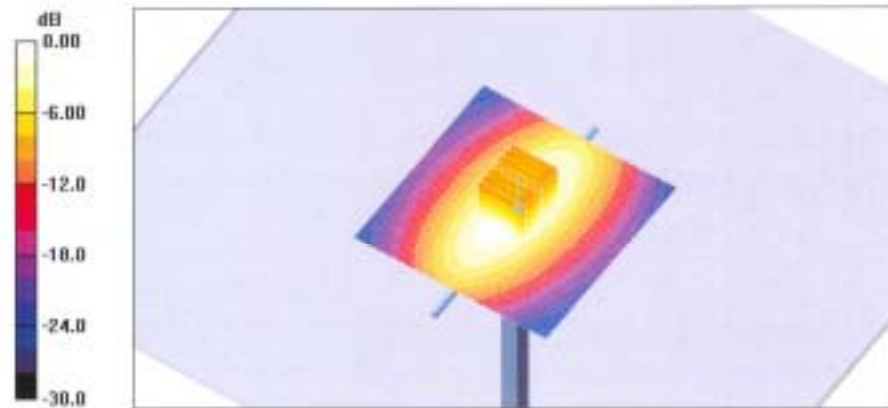

0 dB = 2.96mW/g

DASY4 Validation Report for Head TSL

Date/Time: 25.08.2005 17:04:02

Test Laboratory: SPEAG, Zurich, Switzerland

DUT: Dipole 1900 MHz; Type: D1900V2; Serial: D1900V2 - SN:5d028

Communication System: CW-1900; Frequency: 1900 MHz; Duty Cycle: 1:1

Medium: HSL 1900 MHz;

Medium parameters used: $f = 1900$ MHz; $\sigma = 1.47$ mho/m; $\epsilon_r = 38.6$; $\rho = 1000$ kg/m³

Phantom section: Flat Section

Measurement Standard: DASY4 (High Precision Assessment)

DASY4 Configuration:

- Probe: ET3DV6 - SN1507; CorvF(4.96, 4.96, 4.96); Calibrated: 26.10.2004
- Sensor-Surface: 4mm (Mechanical Surface Detection)
- Electronics: DAE4 Sn001; Calibrated: 07.01.2005
- Phantom: Flat Phantom 5.0 (front); Type: QD000P50AA
- Measurement SW: DASY4, V4.6 Build 9; Postprocessing SW: SEMCAD, V1.8 Build 151

Pin = 250 mW; d = 10 mm/Area Scan (61x81x1):

Measurement grid: dx=15mm, dy=15mm

Maximum value of SAR (interpolated) = 11.8 mW/g

Pin = 250 mW; d = 10 mm/Zoom Scan (7x7x7)/Cube 0:

Measurement grid: dx=5mm, dy=5mm, dz=5mm

Reference Value = 91.5 V/m; Power Drift = 0.00 dB

Peak SAR (extrapolated) = 17.2 W/kg

SAR(1 g) = 9.89 mW/g; SAR(10 g) = 5.16 mW/g

Maximum value of SAR (measured) = 11.2 mW/g

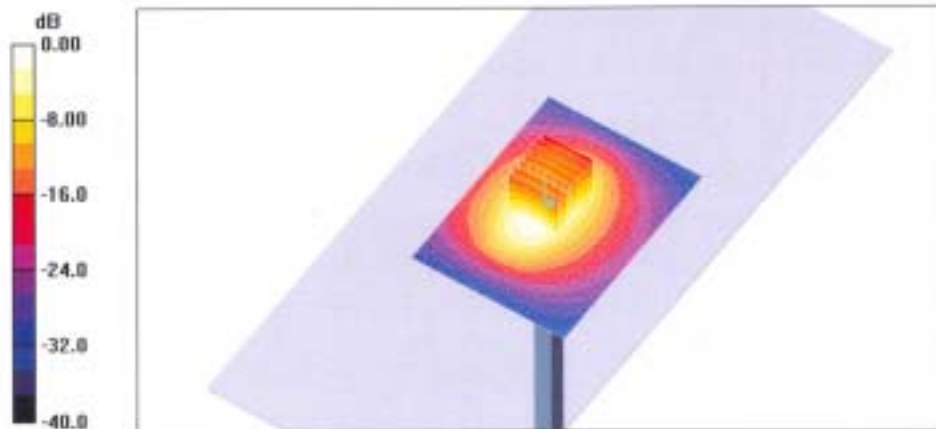

0 dB = 11.2mW/g

DASY4 Validation Report for Body TSL

Date/Time: 26.08.2005 15:32:29

Test Laboratory: SPEAG, Zurich, Switzerland

DUT: Dipole 1900 MHz; Type: D1900V2; Serial: D1900V2 - SN:5d028

Communication System: CW-1900; Frequency: 1900 MHz; Duty Cycle: 1:1

Medium: MSL 1900 MHz;

Medium parameters used: $f = 1900$ MHz; $\sigma = 1.6$ mho/m; $\epsilon_r = 53.3$; $\rho = 1000$ kg/m³

Phantom section: Flat Section

Measurement Standard: DASY4 (High Precision Assessment)

DASY4 Configuration:

- Probe: ET3DV6 - SN1507; ConvP(4.43, 4.43, 4.43); Calibrated: 26.10.2004
- Sensor-Surface: 4mm (Mechanical Surface Detection)
- Electronics: DAE4 Sn601; Calibrated: 07.01.2005
- Phantom: Flat Phantom 5.0 (front); Type: QD000P50AA
- Measurement SW: DASY4, V4.6 Build 9; Postprocessing SW: SEMCAD, V1.8 Build 151

Pin = 250 mW; d = 10 mm 2/Area Scan (81x81x1):

Measurement grid: dx=15mm, dy=15mm

Maximum value of SAR (interpolated) = 11.2 mW/g

Pin = 250 mW; d = 10 mm 2/Zoom Scan (7x7x7)/Cube 0:

Measurement grid: dx=5mm, dy=5mm, dz=5mm

Reference Value = 86.7 V/m; Power Drift = -0.025 dB

Peak SAR (extrapolated) = 16.4 W/kg

SAR(1 g) = 9.81 mW/g; SAR(10 g) = 5.22 mW/g

Maximum value of SAR (measured) = 11.2 mW/g

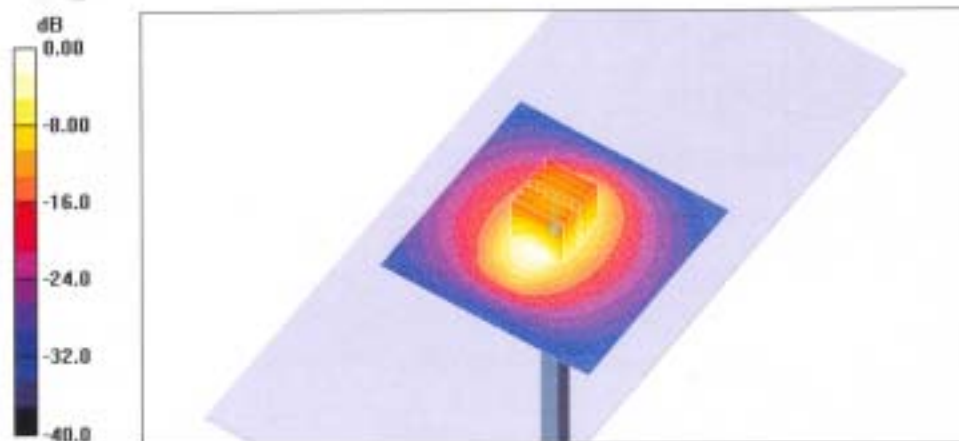

0 dB = 11.2mW/g

The end