

SAR TEST REPORT

Equipment Under Test :	GSM 850&PCS1900MHz MOBILE PHONE
Model No. :	D61a
Market name:	OT-C550a
FCC ID	RAD031
Applicant :	T&A Mobile phones
Address of Applicant :	4/F, No.2966, Jinke Rd, Zhangjiang High-Tech Park, Pudong, Shanghai 201203. P. R. China
Date of Receipt :	2006.05.09
Date of Test :	2006.05.30 – 2006.06.08
Date of Issue :	2006.06.09

Standards:

**FCC OET Bulletin 65 supplement C,
ANSI/IEEE C95.1, C95.3, IEEE 1528-2003**

In the configuration tested, the EUT complied with the standards specified above.

Remarks:

This report details the results of the testing carried out on one sample, the results contained in this test report do not relate to other samples of the same product. The manufacturer should ensure that all products in series production are in conformity with the product sample detailed in this report.

This report may only be reproduced and distributed in full. If the product in this report is used in any configuration other than that detailed in the report, the manufacturer must ensure the new system complies with all relevant standards. Any mention of SGS-CSTC Shanghai GSM Lab or testing done by SGS-CSTC Shanghai GSM Lab must approve SGS Shanghai GSM Lab in connection with distribution or use of the product described in this report in writing.

Tested by :

Roger Ruan

Date :

2006.06.09

Approved by :

Zhang Yuan

Date :

2006.06.09

Contents

1. General Information	5
1.1 Test Laboratory.....	5
1.2 Details of Applicant	5
1.3 Description of EUT(s).....	5
1.4 Test Environment	6
1.5 Operation Configuration	6
1.6 The SAR Measurement System.....	6
1.7 SAR System Verification.....	8
1.8 Tissue Simulant Fluid for the Frequency Band 850MHz and 1900MHZ	9
1.9 Test Standards and Limits	10
2. Summary of Results	11
3. Instruments List	13
4. Measurements	14
4.1 LeftHandSide-Cheek-GSM850-Low	14
FCC-OET65-LeftHandSide-Cheek-GSM850-Low.....	14
4.2 LeftHandSide-Cheek-GSM850-Middle	15
FCC-OET65-LeftHandSide-Cheek-GSM850-Mid	15
4.3 LeftHandSide-Cheek-GSM850-High	17
FCC-OET65-LeftHandSide-Cheek-GSM850-High	17
4.4 LeftHandSide-Tilt-GSM850-Low	18
FCC-OET65-LeftHandSide-Tilt-GSM850-Low	18
4.5 LeftHandSide-Tilt-GSM850-Middle	20
FCC-OET65-LeftHandSide-Tilt-GSM850-Mid.....	20
4.6 LeftHandSide-Tilt-GSM850-High	21
FCC-OET65-LeftHandSide-Tilt-GSM850-High.....	21
4.7 RightHandSide-Cheek-GSM850-Low	23
FCC-OET65-RightHandSide-Cheek-GSM850-Low.....	23
4.8 RightHandSide-Cheek-GSM850-Middle	24
FCC-OET65-RightHandSide-Cheek-GSM850-Mid	24
4.9 RightHandSide-Cheek-GSM850-High	26
FCC-OET65-RightHandSide-Cheek-GSM850-High	26
4.10 RightHandSide-Tilt-GSM850-Low	27
FCC-OET65-RightHandSide-Tilt-GSM850-Low	27

4.11RightHandSide-Tilt-GSM850-Middle.....	29
FCC-OET65-RightHandSide-Tilt-GSM850-Mid.....	29
4.12RightHandSide-Tilt-GSM850-High.....	30
FCC-OET65-RightHandSide-Tilt-GSM850-High	30
4.13Body-Worn-GSM850-GPRS-Low	32
FCC-OET65-Body-Worn-GSM850-GPRS-Low-2cm.....	32
4.14Body-Worn-GSM850-GPRS-Middle	33
FCC-OET65-Body-Worn-GSM850-GPRS-Mid-2cm	33
4.15Body-Worn-GSM850-GPRS-High	35
FCC-OET65-Body-Worn-GSM850-GPRS-High-2cm.....	35
4.16LeftHandSide-Cheek-PCS1900-Low.....	36
FCC-OET65-LeftHandSide-Cheek-PCS1900-Low	36
4.17LeftHandSide-Cheek-PCS1900-Middle.....	38
FCC-OET65-LeftHandSide-Cheek-PCS1900-Mid	38
4.18LeftHandSide-Cheek-PCS1900-High	40
FCC-OET65-LeftHandSide-Cheek-PCS1900-High.....	40
4.19LeftHandSide-Tilt-PCS1900-Low	42
FCC-OET65-LeftHandSide-Tilt-PCS1900-Low.....	42
4.20LeftHandSide-Tilt-PCS1900-Middle	44
FCC-OET65-LeftHandSide-Tilt-PCS1900-Mid	44
4.21LeftHandSide-Tilt-PCS1900-High	46
FCC-OET65-LeftHandSide-Tilt-PCS1900-High	46
4.22RightHandSide-Cheek-PCS1900-Low	48
FCC-OET65-RightHandSide-Cheek-PCS1900-Low	48
4.23RightHandSide-Cheek-PCS1900-Middle.....	50
FCC-OET65-RightHandSide-Cheek-PCS1900-Mid.....	50
4.24RightHandSide-Cheek-PCS1900-High	52
FCC-OET65-RightHandSide-Cheek-PCS1900-High.....	52
4.25RightHandSide-Tilt-PCS1900-Low	53
FCC-OET65-RightHandSide-Tilt-PCS1900-Low.....	53
4.26RightHandSide-Tilt-PCS1900-Middle	55
FCC-OET65-RightHandSide-Tilt-PCS1900-Mid	55
4.27RightHandSide-Tilt-PCS1900-High.....	56
FCC-OET65-RightHandSide-Tilt-PCS1900-High.....	56
4.28Body-Worn-PCS1900-GPRS-Low	58

FCC-OET65-Body-Worn-PCS1900-GPRS-Low-2cm	58
4.29Body-Worn-PCS1900-GPRS-Middle.....	59
FCC-OET65-Body-Worn-PCS1900-GPRS-Mid-2cm.....	59
4.30Body-Worn-PCS1900-GPRS-High	61
FCC-OET65-Body-Worn-PCS1900-GPRS-High-2cm.....	61
Appendix	63
1. Photographs of Test Setup.....	63
2. Photographs of the EUT	66
3. Photographs of the battery.....	67
4. Photograph of the charger	67
5. Probe Calibration certificate.....	68
6. Uncertainty analysis	77
7. Phantom description	78
8. System validation from original equipment supplier	79

1. General Information

1.1 Test Laboratory

GSM Lab
 SGS-CSTC Standards Technical Services Co.Ltd Shanghai Branch
 9F,the 3rd Building, No.889, Yishan Rd, Xuhui District, Shanghai, China
 Zip code: 200233
 Telephone: +86 (0) 21 6495 1616
 Fax: +86 (0) 21 6495 3679
 Internet: <http://www.cn.sgs.com>

1.2 Details of Applicant

Name: T&A Mobile phones
 Address: 4/F, No.2966, Jinke Rd, Zhangjiang High-Tech Park, Pudong
 Shanghai 201203. P. R. China

1.3 Description of EUT(s)

Brand name	ALCATEL	
Model No.	D61a	
Market Name	OT-C550a	
Serial No.	IMEI: 01089800000051-8	
Battery Type	Lithium-Ion	
Antenna Type	Internal Antenna	
Operation Mode	GSM850/PCS1900	
Modulation Mode	GMSK	
Frequency range	GSM850	Tx: 824~849 MHz
		Rx: 869~894 MHz
	PCS1900	Tx: 1850~1910 MHz
		Rx: 1930~1990 MHz
Maximum RF Conducted Power	GSM850: 33dBm, PCS1900: 30dBm	
GPRS	Multi-Slot class 10 uplink 2TS	

1.4 Test Environment

Ambient temperature: 22.0° C

Tissue Simulating Liquid: 22° C

Relative Humidity: 29%~35%

1.5 Operation Configuration

Configuration 1: GSM 850, LeftHandSide Cheek & 15° Tilt Position

Configuration 2: GSM 850, RightHandSide Cheek & 15° Tilt Position

Configuration 3: GSM 850, BodyWorn (2.0 cm between EUT and phantom)

Configuration 4: PCS 1900, LeftHandSide Cheek & 15° Tilt Position

Configuration 5: PCS 1900, RightHandSide Cheek & 15° Tilt Position

Configuration 6: PCS 1900, BodyWorn (2.0 cm between EUT and phantom)

1.6 The SAR Measurement System

A photograph of the SAR measurement System is given in Fig.a.

This SAR Measurement System uses a Computer-controlled 3-D stepper motor system (Speag Dasy 4 professional system). A Model ES3DV3 3088 E-field probe is used to determine the internal electric fields. The SAR can be obtained from the equation $SAR = \sigma (|E_i|^2) / \rho$ where σ and ρ are the conductivity and mass density of the tissue-simulant.

The DASY4 system for performing compliance tests consists of the following items:

- ÿ A standard high precision 6-axis robot (Stabile RX family) with controller, teach pendant and software. An arm extension for accommodation the data acquisition electronics (DAE).
- ÿ A dosimetric probe, i.e., an isotropic E-field probe optimized and calibrated for usage in tissue simulating liquid. The probe is equipped with an optical surface detector system.
- ÿ A data acquisition electronics (DAE) which performs the signal amplification, signal multiplexing, AD-conversion, offset measurements, mechanical surface detection, collision detection, etc. The unit is battery powered with standard or rechargeable batteries. The signal is optically transmitted to the EOC.

- Y The Electro-optical converter (EOC) performs the conversion between optical and electrical of the signals for the digital communication to DAE and for the analog signal from the optical surface detection. The EOC is connected to the measurement server.

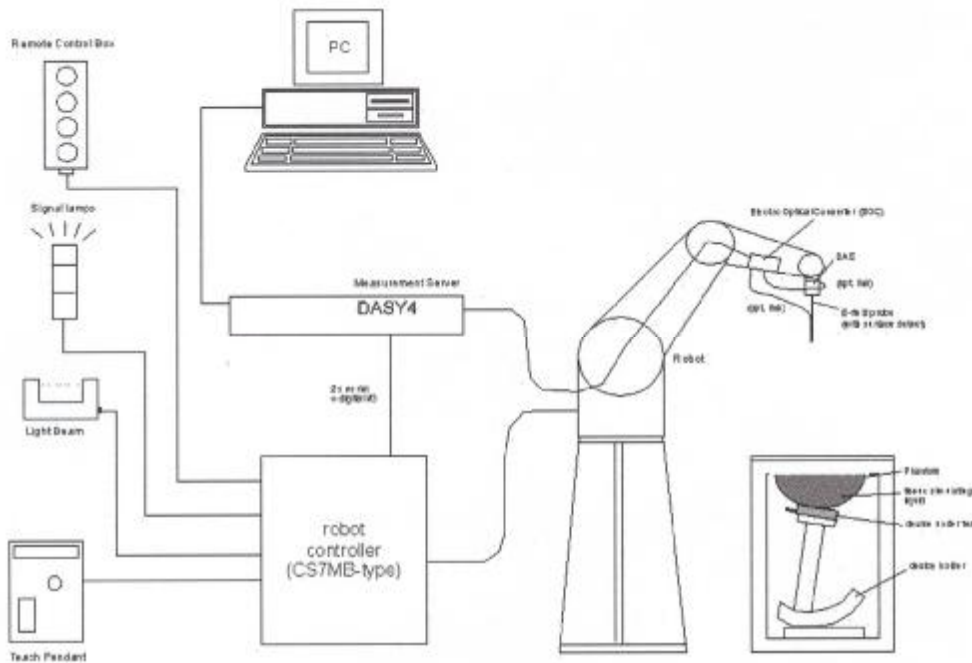

Fig. a SAR System Configuration

- Y The function of the measurement server is to perform the time critical tasks such as signal filtering, control of the robot operation and fast movement interrupts.
- Y A probe alignment unit which improves the (absolute) accuracy of the probe positioning.
- Y A computer operating Windows 2000.
- Y DASY4 software.
- Y Remote control with teach pendant and additional circuitry for robot safety such as warning lamps, etc.
- Y The SAM twin phantom enabling testing left-hand, right-hand and body-worn usage.
- Y The device holder for handheld mobile phones.
- Y Tissue simulating liquid mixed according to the given recipes.

γ Validation dipole kits allowing to validating the proper functioning of the system.

1.7 SAR System Verification

The microwave circuit arrangement for system verification is sketched in Fig. b. The daily system accuracy verification occurs within the flat section of the SAM phantom. A SAR measurement was performed to see if the measured SAR was within +/- 10% from the target SAR values. These tests were done at 900MHz and 1900MHz. The tests were conducted on the same days as the measurement of the DUT. The obtained results from the system accuracy verification are displayed in the table 1 (SAR values are normalized to 1W forward power delivered to the dipole). During the tests, the ambient temperature of the laboratory was in the range 22°C, the relative humidity was in the range 60% and the liquid depth above the ear reference points was above 15 cm in all the cases. It is seen that the system is operating within its specification, as the results are within acceptable tolerance of the reference values.

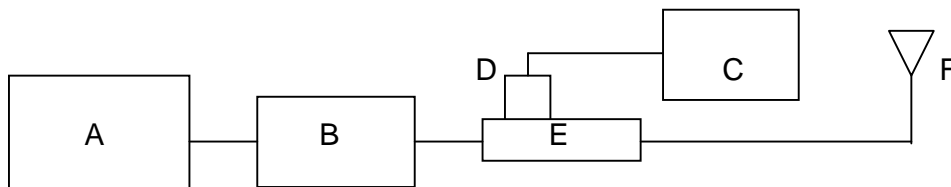

Fig. b the microwave circuit arrangement used for SAR system verification

- A. Agilent Model E4438C Signal Generator
- B. Mini-Circuit Model ZHL-42 Pre-amplifier
- C. Agilent Model E4416A Power Meter
- D. Agilent Model 8481H Power Sensor
- E. HT CP6100 20N Dual directional coupler
- F. Reference dipole antenna

Validation Kit	Frequency MHz	Target SAR 1g (250mW)	Target SAR 10g (250mW)	Measured SAR 1g	Measured SAR 10g	Measured Date
ES3DV3 SN3088	850 Head	2.6	1.67	2.69	1.68	2006-05-31
ES3DV3 SN3088	850 Body	2.69	1.74	2.77	1.75	2006-06-04
ES3DV3 SN3088	1900 Head	9.89	5.16	9.63	5.05	2006-06-02
ES3DV3 SN3088	1900 Body	9.81	5.22	9.62	5.14	2006-05-30

Table 1. Result System Validation

1.8 Tissue Simulant Fluid for the Frequency Band 850MHz and 1900MHz

The dielectric properties for this body-simulant fluid were measured by using the HP Model 85070D Dielectric Probe (rates frequency band 200 MHz to 20 GHz) in conjunction with Agilent E5071B Network Analyzer (300 KHz-8500 MHz). The Conductivity (σ) and Permittivity (ρ) are listed in Table 2. For the SAR measurement given in this report. The temperature variation of the Tissue Simulant Fluid was 22°C.

Frequency (MHz)	Tissue Type	Limit/Measured	Permittivity (ρ)	Conductivity (σ)	Simulated Tissue Temp (°C)
850	Head	Measured, 2006-05-31	41.47	0.897	22.5
		Recommended Limit	41.5±5%	0.97±5%	20-24
	Body	Measured, 2006-06-04	52.35	1.026	22.5
		Recommended Limit	55.0±5%	1.05±5%	20-24
1900	Head	Measured, 2006-06-02	39.83	1.463	22.3
		Recommended Limit	40.0±5%	1.40±5%	20-24
	Body	Measured, 2006-05-30	51.45	1.564	22.6
		Recommended Limit	53.3±5%	1.52±5%	20-24

Table 2. Dielectric parameters for the Frequency Band 850MHz&1900MHZ

1.9 Test Standards and Limits

According to FCC 47 CFR §2.1093(d) the limits to be used for evaluation are based generally on criteria published by the American National Standards Institute (ANSI) for localized specific absorption rate (SAR) in Section 4.2 of "IEEE Standard for Safety Levels with Respect to Human Exposure to Radio Frequency Electromagnetic Fields, 3KHz to 300GHz," ANSI/IEEE C95.1-1992, Copyright 1992 by the Institute of Electrical & Electronics Engineers, Inc., New York, New York 10071.

Human Exposure	Uncontrolled Environment General Population
Spatial Peak SAR (Brain)	1.60 mW/g (averaged over a mass of 1g)

Table 3. RF Exposure Limits

Notes:

1. Uncontrolled environments are defined as locations where there is potential exposure of the individuals who have no knowledge or control of their potential exposure.

2. Summary of Results

Frequency Band(MHz)	EUT position	Conducted Output Power (dBm)	1g Avg. (mW/g)	10g Avg. (mW/g)	Power Drift (dB)	Amb. Temp (°C)	Verdict
GSM 850	LeftHandSide Cheek, Low Channel	32.6	0.949	0.690	-0.168	22	PASS
	LeftHandSide Cheek, Mid Channel	32.4	0.723	0.525	-0.042	22	PASS
	LeftHandSide Cheek, High Channel	32.2	0.471	0.342	-0.009	22	PASS
	LeftHandSide Tilt, Low Channel	32.6	0.794	0.493	-0.210	22	PASS
	LeftHandSide Tilt, Mid Channel	32.4	0.589	0.364	-0.202	22	PASS
	LeftHandSide Tilt, High Channel	32.2	0.371	0.231	0.005	22	PASS
	RightHandSide Cheek, Low Channel	32.6	1.09	0.784	-0.222	22	PASS
	RightHandSide Cheek, Mid Channel	32.4	0.800	0.576	-0.093	22	PASS
	RightHandSide Cheek, High Channel	32.2	0.525	0.376	0.019	22	PASS
	RightHandSide Tilt, Low Channel	32.6	0.713	0.472	-0.221	22	PASS
	RightHandSide Tilt, Mid Channel	32.4	0.525	0.346	-0.085	22	PASS
	RightHandSide Tilt, High Channel	32.2	0.336	0.220	-0.117	22	PASS
GSM 850	GPRS,BodyWorn, Low Channel	32.6	0.965	0.672	-0.308	22	PASS
	GPRS,BodyWorn, Mid Channel	32.4	0.729	0.504	-0.039	22	PASS
	GPRS,BodyWorn, High Channel	32.2	0.491	0.341	-0.042	22	PASS
PCS 1900	LeftHandSide Cheek, Low Channel	29.0	0.635	0.338	-0.013	22	PASS
	LeftHandSide Cheek, Mid Channel	29.1	0.671	0.355	-0.071	22	PASS
	LeftHandSide Cheek, High Channel	29.3	0.673	0.349	-0.142	22	PASS
	LeftHandSide Tilt, Low Channel	29.0	0.942	0.497	-0.015	22	PASS
	LeftHandSide Tilt, Mid Channel	29.1	1	0.525	-0.042	22	PASS
	LeftHandSide Tilt, High Channel	29.3	0.784	0.409	0.007	22	PASS

	RightHandSide Cheek, Low Channel	29.0	0.553	0.308	-0.066	22	PASS
	RightHandSide Cheek, Mid Channel	29.1	0.572	0.315	-0.126	22	PASS
	RightHandSide Cheek, High Channel	29.3	0.525	0.290	-0.124	22	PASS
	RightHandSide Tilt, Low Channel	29.0	0.994	0.530	-0.015	22	PASS
	RightHandSide Tilt, Mid Channel	29.1	1.05	0.560	-0.032	22	PASS
	RightHandSide Tilt, High Channel	29.3	0.881	0.467	-0.099	22	PASS
PCS 1900	GPRS,BodyWorn, Low Channel	29.0	0.628	0.361	-0.117	22	PASS
	GPRS,BodyWorn, Mid Channel	29.1	0.574	0.330	-0.096	22	PASS
	GPRS,BodyWorn, High Channel	29.3	0.441	0.253	-0.082	22	PASS

Maximum Values

Frequency Band(MHz)	EUT position	Conducted Output Power (dBm)	1g Average (W/Kg)	10g Average (W/Kg)	Power Drift (dB)	Amb. Temp (°C)	Verdict
GSM850	RightHandSide Cheek, Low Channel	32.6	1.09	0.784	-0.222	22	PASS
	GPRS,BodyWorn, Low Channel	32.6	0.965	0.672	-0.308	22	PASS
PCS1900	RightHandSide Tilt, Mid Channel	29.1	1.05	0.560	-0.032	22	PASS
	GPRS,BodyWorn, Low Channel	29.0	0.628	0.361	-0.117	22	PASS

Note:

1. In GSM850 band, the low, middle and high channels are CH128/824.2MHz, CH189/836.4MHz and CH251/848.8MHz separately.
2. In PCS1900 band, the low, middle and high channels are CH512/1805.2MHz, CH661/1880.0MHz and CH810/1909.8MHz separately.
3. For the Bodyworn measurements the sample was only placed with the antenna toward the phantom since this position delivers the highest SAR values.
4. For the Bodyworn measurements, the distance from the sample to the phantom is 2.0 cm.

3. Instruments List

Instrument	Model	Serial number	NO.	Date of last Calibration
Desktop PC	COMPAQ EVO	N/A	GSM-SAR-025	N/A
Dasy 4 software	V 4.6 build 23	N/A	GSM-SAR-001	N/A
Probe	ES3DV3	3088	GSM-SAR-034	2005.09.13
DAE	DAE3	569	GSM-SAR-023	2005.11.17
Phantom	SAM 12	TP-1283	GSM-SAR-005	N/A
Robot	RX90L	F03/5V32A1/A01	GSM-SAR-008	N/A
900MHz system validation dipole	D900V2	184	GSM-SAR-013	2005.8.22
1900MHz system validation dipole	D1900V2	5d028	GSM-SAR-020	2005.8.25
Dielectric probe kit	85070D	US01440168	GSM-SAR-016	2005.12.19
Agilent network analyzer	E5071B	MY42100549	GSM-SAR-007	2005.12.19
Agilent signal generator	E4438	14438CATO-19719	GSM-SAR-008	2005.12.19
Mini-Circuits preamplifier	ZHL-42	D041905	GSM-SAR-033	2005.05.20
Agilent power meter	E4416A	GB41292095	GSM-SAR-010	2005.12.19
Agilent power sensor	8481H	MY41091234	GSM-SAR-011	2005.12.19
HT CP6100 20N Coupling	6100	SCP301480120	GSM-SAR-012	2005.12.19
R&S Universal radio communication tester	CMU200	103633	GSM-AUD-002	2005.12.20

4. Measurements

4.1 LeftHandSide-Cheek-GSM850-Low

Date/Time: 2006-6-1 16:00:15

Test Laboratory: SGS-GSM

FCC-OET65-LeftHandSide-Cheek-GSM850-Low

DUT: GSM10000292E; Type: Head; Serial: 20060525

Communication System: GSM850-GSM Mode; Frequency: 824.2 MHz; Duty Cycle: 1:8.3

Medium: HSL850 Medium parameters used (interpolated): $f = 824.2$ MHz; $\sigma = 0.866$ mho/m; $\epsilon_r = 41.8$;
 $\rho = 1000$ kg/m³

Phantom section: Left Section

Measurement Standard: DASYS4 (High Precision Assessment)

DASY4 Configuration:

- Probe: ES3DV3 - SN3088; ConvF(5.91, 5.91, 5.91); Calibrated: 2005-9-13
- Sensor-Surface: 4mm (Mechanical Surface Detection)
- Electronics: DAE3 Sn569; Calibrated: 2005-11-17
- Phantom: SAM 12; Type: SAM V4.0; Serial: TP-1283
- Measurement SW: DASYS4, V4.6 Build 23; Postprocessing SW: SEMCAD, V1.8 Build 160

Cheek position - Low/Area Scan (61x101x1): Measurement grid: dx=15mm, dy=15mm

Maximum value of SAR (interpolated) = 1.12 mW/g

Cheek position - Low/Zoom Scan (7x7x7)/Cube 0: Measurement grid: dx=5mm, dy=5mm, dz=5mm

Reference Value = 32.1 V/m; Power Drift = -0.168 dB

Peak SAR (extrapolated) = 1.30 W/kg

SAR(1 g) = 0.949 mW/g; SAR(10 g) = 0.690 mW/g

Maximum value of SAR (measured) = 1.01 mW/g

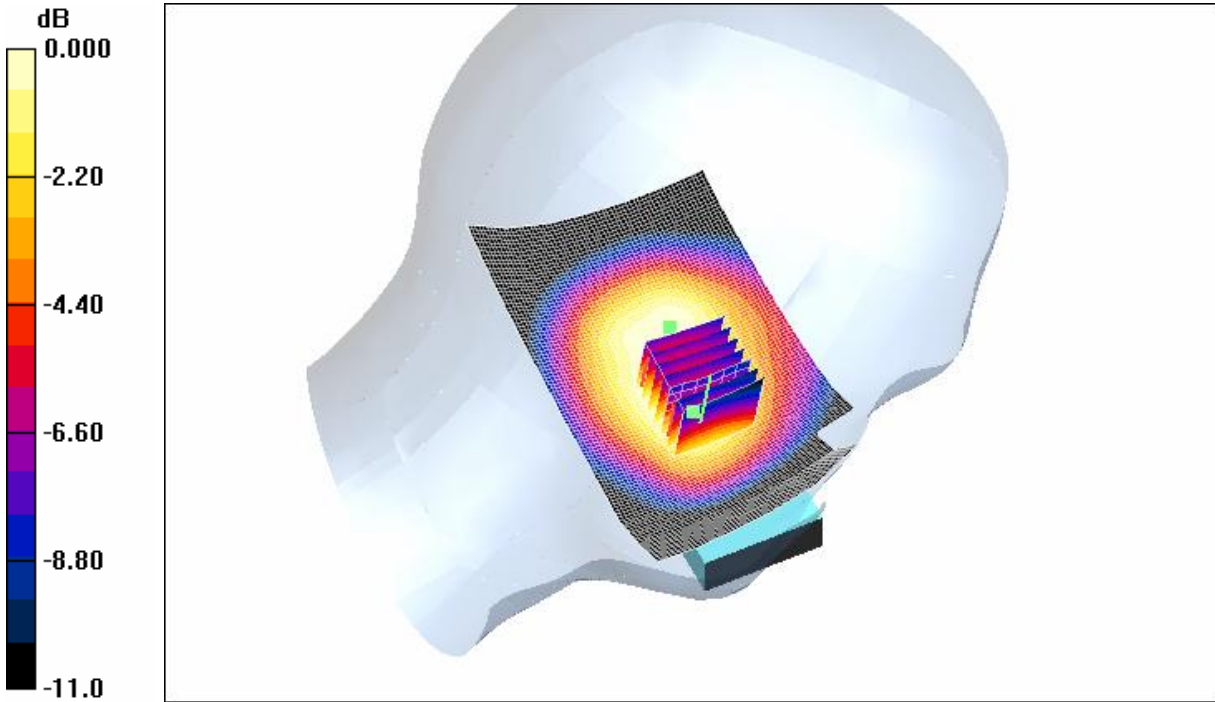

0 dB = 1.01mW/g

4.2LeftHandSide-Cheek-GSM850-Middle

Date/Time: 2006-6-1 16:24:41

Test Laboratory: SGS-GSM

FCC-OET65-LeftHandSide-Cheek-GSM850-Mid

DUT: GSM10000292E; Type: Head; Serial: 20060525

Communication System: GSM850-GSM Mode; Frequency: 836.4 MHz;Duty Cycle: 1:8.3

Medium: HSL850 Medium parameters used (interpolated): $f = 836.4$ MHz; $\sigma = 0.878$ mho/m; $\epsilon_r = 41.7$;

$\rho = 1000$ kg/m³

Phantom section: Left Section

Measurement Standard: DAS4 (High Precision Assessment)

DASY4 Configuration:

- Probe: ES3DV3 - SN3088; ConvF(5.91, 5.91, 5.91); Calibrated: 2005-9-13
- Sensor-Surface: 4mm (Mechanical Surface Detection)
- Electronics: DAE3 Sn569; Calibrated: 2005-11-17
- Phantom: SAM 12; Type: SAM V4.0; Serial: TP-1283
- Measurement SW: DASY4, V4.6 Build 23; Postprocessing SW: SEMCAD, V1.8 Build 160

Cheek position - Mid/Area Scan (61x101x1): Measurement grid: dx=15mm, dy=15mm

Maximum value of SAR (interpolated) = 0.840 mW/g

Cheek position - Mid/Zoom Scan (7x7x7) (7x7x7)/Cube 0: Measurement grid: dx=5mm, dy=5mm, dz=5mm

Reference Value = 27.4 V/m; Power Drift = -0.042 dB

Peak SAR (extrapolated) = 0.996 W/kg

SAR(1 g) = 0.723 mW/g; SAR(10 g) = 0.525 mW/g

Maximum value of SAR (measured) = 0.774 mW/g

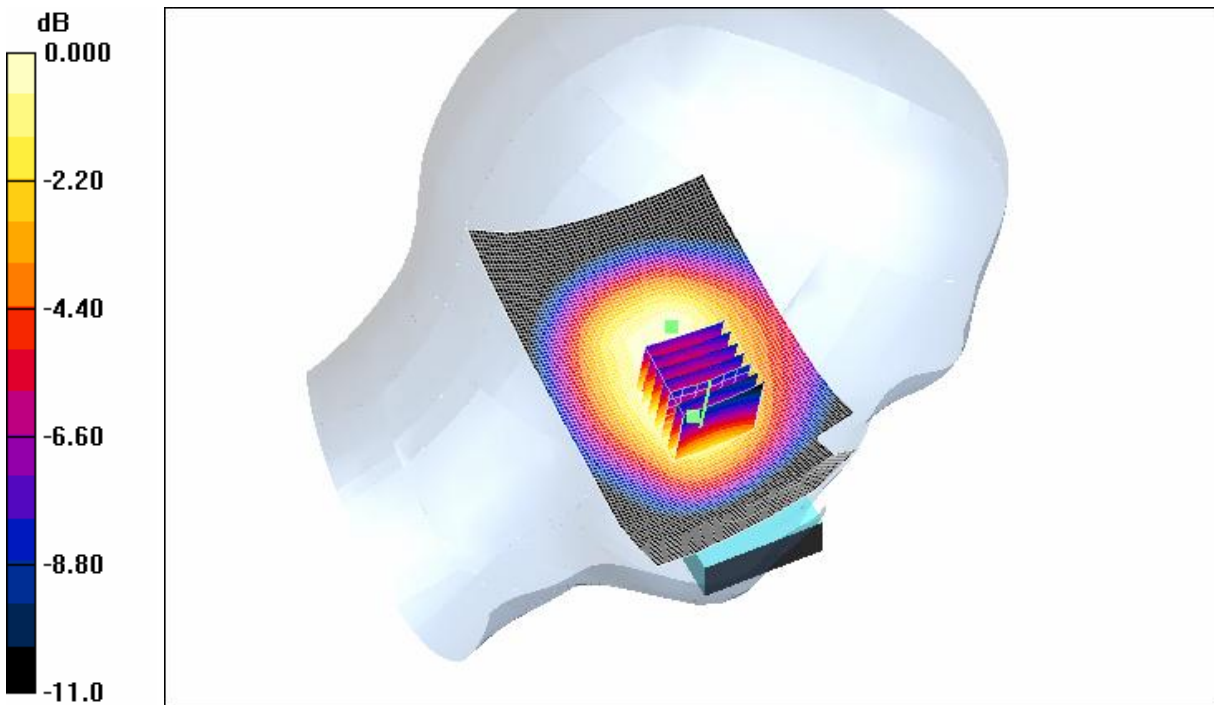

0 dB = 0.774mW/g

4.3LeftHandSide-Cheek-GSM850-High

Date/Time: 2006-6-1 16:49:02

Test Laboratory: SGS-GSM

FCC-OET65-LeftHandSide-Cheek-GSM850-High

DUT: GSM10000292E; Type: Head; Serial: 20060525

Communication System: GSM850-GSM Mode; Frequency: 848.8 MHz;Duty Cycle: 1:8.3

Medium: HSL850 Medium parameters used: $f = 849$ MHz; $\sigma = 0.89$ mho/m; $\epsilon_r = 41.6$; $\rho = 1000$ kg/m³

Phantom section: Left Section

Measurement Standard: DASYS4 (High Precision Assessment)

DASY4 Configuration:

- Probe: ES3DV3 - SN3088; ConvF(5.91, 5.91, 5.91); Calibrated: 2005-9-13
- Sensor-Surface: 4mm (Mechanical Surface Detection)
- Electronics: DAE3 Sn569; Calibrated: 2005-11-17
- Phantom: SAM 12; Type: SAM V4.0; Serial: TP-1283
- Measurement SW: DASYS4, V4.6 Build 23; Postprocessing SW: SEMCAD, V1.8 Build 160

Cheek position - High/Area Scan (61x101x1): Measurement grid: dx=15mm, dy=15mm

Maximum value of SAR (interpolated) = 0.539 mW/g

Cheek position - High/Zoom Scan (7x7x7) (7x7x7)/Cube 0: Measurement grid: dx=5mm, dy=5mm, dz=5mm

Reference Value = 21.9 V/m; Power Drift = -0.009 dB

Peak SAR (extrapolated) = 0.648 W/kg

SAR(1 g) = 0.471 mW/g; SAR(10 g) = 0.342 mW/g

Maximum value of SAR (measured) = 0.505 mW/g

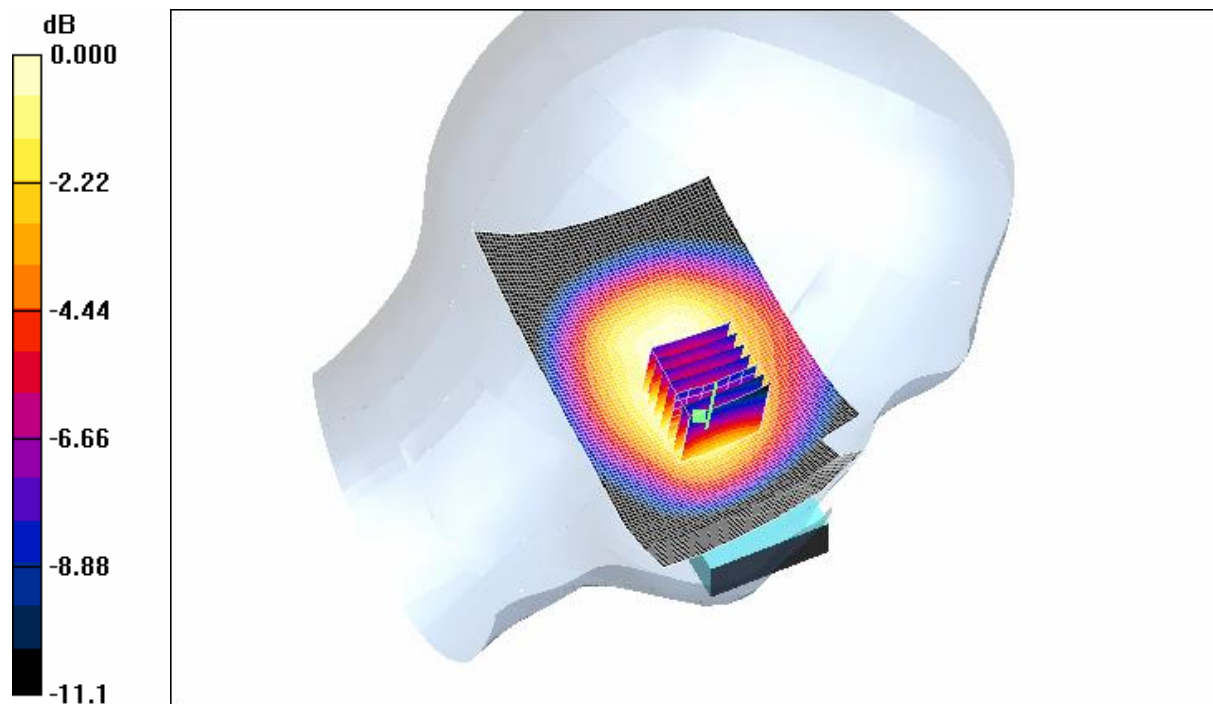

0 dB = 0.505mW/g

4.4LeftHandSide-Tilt-GSM850-Low

Date/Time: 2006-6-1 17:23:44

Test Laboratory: SGS-GSM

FCC-OET65-LeftHandSide-Tilt-GSM850-Low

DUT: GSM10000292E; Type: Head; Serial: 20060525

Communication System: GSM850-GSM Mode; Frequency: 824.2 MHz;Duty Cycle: 1:8.3

Medium: HSL850 Medium parameters used (interpolated): $f = 824.2$ MHz; $\sigma = 0.866$ mho/m; $\epsilon_r = 41.8$;

$\rho = 1000$ kg/m³

Phantom section: Left Section

Measurement Standard: DAS4 (High Precision Assessment)

DASY4 Configuration:

- Probe: ES3DV3 - SN3088; ConvF(5.91, 5.91, 5.91); Calibrated: 2005-9-13
- Sensor-Surface: 4mm (Mechanical Surface Detection)
- Electronics: DAE3 Sn569; Calibrated: 2005-11-17
- Phantom: SAM 12; Type: SAM V4.0; Serial: TP-1283
- Measurement SW: DASY4, V4.6 Build 23; Postprocessing SW: SEMCAD, V1.8 Build 160

Tilt position - Low/Area Scan (61x101x1): Measurement grid: dx=15mm, dy=15mm

Maximum value of SAR (interpolated) = 0.832 mW/g

Tilt position - Low/Zoom Scan (7x7x7)/Cube 0: Measurement grid: dx=5mm, dy=5mm, dz=5mm

Reference Value = 30.7 V/m; Power Drift = -0.210 dB

Peak SAR (extrapolated) = 1.42 W/kg

SAR(1 g) = 0.794 mW/g; SAR(10 g) = 0.493 mW/g

Maximum value of SAR (measured) = 0.889 mW/g

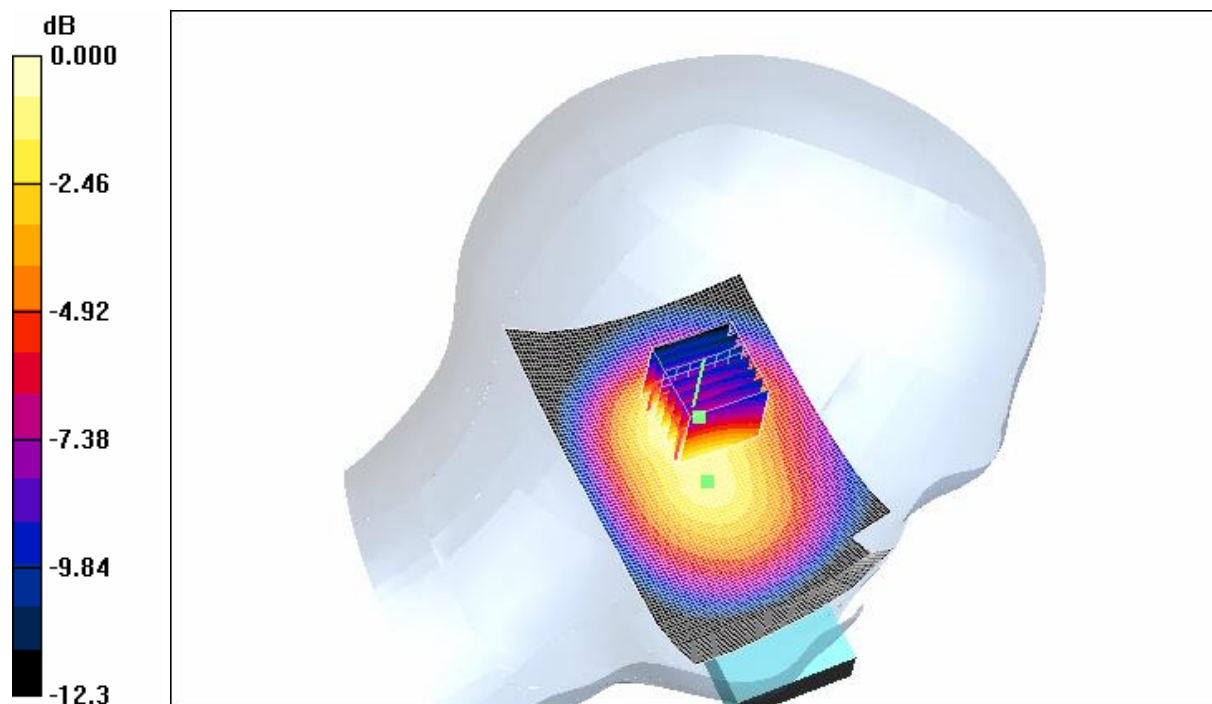

0 dB = 0.889mW/g

4.5LeftHandSide-Tilt-GSM850-Middle

Date/Time: 2006-6-1 17:48:32

Test Laboratory: SGS-GSM

FCC-OET65-LeftHandSide-Tilt-GSM850-Mid

DUT: GSM10000292E; Type: Head; Serial: 20060525

Communication System: GSM850-GSM Mode; Frequency: 836.4 MHz;Duty Cycle: 1:8.3

Medium: HSL850 Medium parameters used (interpolated): $f = 836.4$ MHz; $\sigma = 0.878$ mho/m; $\epsilon_r = 41.7$;
 $\rho = 1000$ kg/m³

Phantom section: Left Section

Measurement Standard: DAS4 (High Precision Assessment)

DASY4 Configuration:

- Probe: ES3DV3 - SN3088; ConvF(5.91, 5.91, 5.91); Calibrated: 2005-9-13
- Sensor-Surface: 4mm (Mechanical Surface Detection)
- Electronics: DAE3 Sn569; Calibrated: 2005-11-17
- Phantom: SAM 12; Type: SAM V4.0; Serial: TP-1283
- Measurement SW: DAS4, V4.6 Build 23; Postprocessing SW: SEMCAD, V1.8 Build 160

Tilt position - Middle/Area Scan (61x101x1): Measurement grid: dx=15mm, dy=15mm

Maximum value of SAR (interpolated) = 0.602 mW/g

Tilt position - Middle/Zoom Scan (7x7x7) (7x7x7)/Cube 0: Measurement grid: dx=5mm, dy=5mm,
dz=5mm

Reference Value = 26.1 V/m; Power Drift = -0.202 dB

Peak SAR (extrapolated) = 1.06 W/kg

SAR(1 g) = 0.589 mW/g; SAR(10 g) = 0.364 mW/g

Maximum value of SAR (measured) = 0.661 mW/g

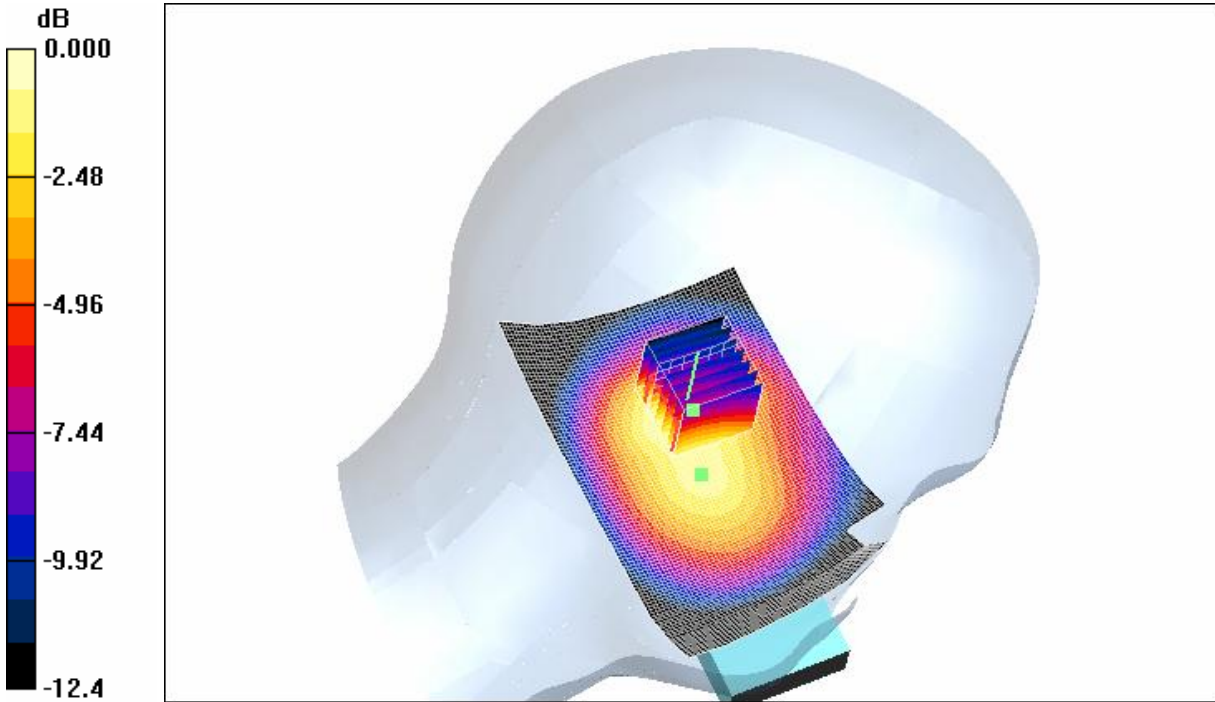

0 dB = 0.661mW/g

4.6LeftHandSide-Tilt-GSM850-High

Date/Time: 2006-6-1 18:16:35

Test Laboratory: SGS-GSM

FCC-OET65-LeftHandSide-Tilt-GSM850-High

DUT: GSM10000292E; Type: Head; Serial: 20060525

Communication System: GSM850-GSM Mode; Frequency: 848.8 MHz;Duty Cycle: 1:8.3

Medium: HSL850 Medium parameters used: $f = 849$ MHz; $\sigma = 0.89$ mho/m; $\epsilon_r = 41.6$; $\rho = 1000$ kg/m³

Phantom section: Left Section

Measurement Standard: DAS4 (High Precision Assessment)

DASY4 Configuration:

- Probe: ES3DV3 - SN3088; ConvF(5.91, 5.91, 5.91); Calibrated: 2005-9-13

- Sensor-Surface: 4mm (Mechanical Surface Detection)
- Electronics: DAE3 Sn569; Calibrated: 2005-11-17
- Phantom: SAM 12; Type: SAM V4.0; Serial: TP-1283
- Measurement SW: DASY4, V4.6 Build 23; Postprocessing SW: SEMCAD, V1.8 Build 160

Tilt position - High/Area Scan (61x101x1): Measurement grid: dx=15mm, dy=15mm

Maximum value of SAR (interpolated) = 0.384 mW/g

Tilt position - High/Zoom Scan (7x7x7) (7x7x7)/Cube 0: Measurement grid: dx=5mm, dy=5mm, dz=5mm

Reference Value = 20.4 V/m; Power Drift = 0.005 dB

Peak SAR (extrapolated) = 0.666 W/kg

SAR(1 g) = 0.371 mW/g; SAR(10 g) = 0.231 mW/g

Maximum value of SAR (measured) = 0.412 mW/g

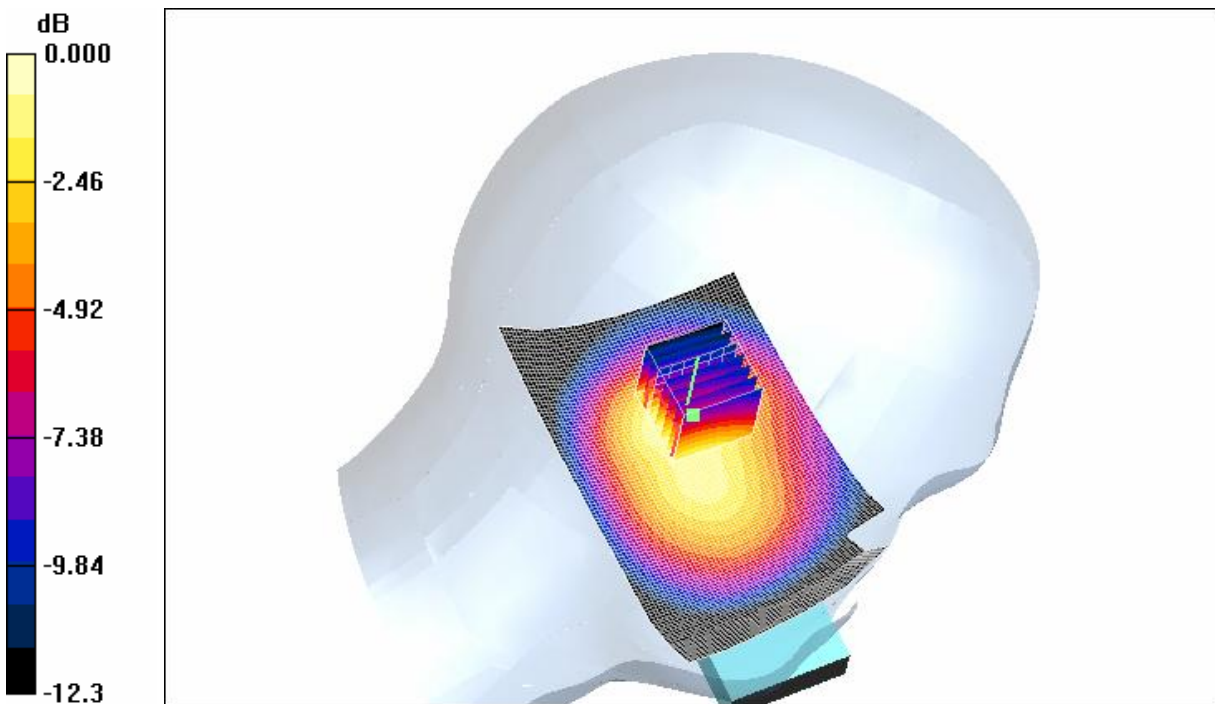

0 dB = 0.412mW/g

4.7RightHandSide-Cheek-GSM850-Low

Date/Time: 2006-5-31 11:36:55

Test Laboratory: SGS-GSM

FCC-OET65-RightHandSide-Cheek-GSM850-Low

DUT: GSM10000292E; Type: Head; Serial: 20060525

Communication System: GSM850-GSM Mode; Frequency: 824.2 MHz; Duty Cycle: 1:8.3

Medium: HSL850 Medium parameters used (interpolated): $f = 824.2$ MHz; $\sigma = 0.866$ mho/m; $\epsilon_r = 41.8$;
 $\rho = 1000$ kg/m³

Phantom section: Right Section

Measurement Standard: DAS4 (High Precision Assessment)

DAS4 Configuration:

- Probe: ES3DV3 - SN3088; ConvF(5.91, 5.91, 5.91); Calibrated: 2005-9-13
- Sensor-Surface: 4mm (Mechanical Surface Detection)
- Electronics: DAE3 Sn569; Calibrated: 2005-11-17
- Phantom: SAM 12; Type: SAM V4.0; Serial: TP-1283
- Measurement SW: DAS4, V4.6 Build 23; Postprocessing SW: SEMCAD, V1.8 Build 160

Cheek position - Low/Area Scan (61x101x1): Measurement grid: dx=15mm, dy=15mm

Maximum value of SAR (interpolated) = 1.24 mW/g

Cheek position - Low/Zoom Scan (7x7x7) (7x7x7)/Cube 0: Measurement grid: dx=5mm, dy=5mm,
dz=5mm

Reference Value = 32.3 V/m; Power Drift = -0.222 dB

Peak SAR (extrapolated) = 1.54 W/kg

SAR(1 g) = 1.09 mW/g; SAR(10 g) = 0.784 mW/g

Maximum value of SAR (measured) = 1.18 mW/g

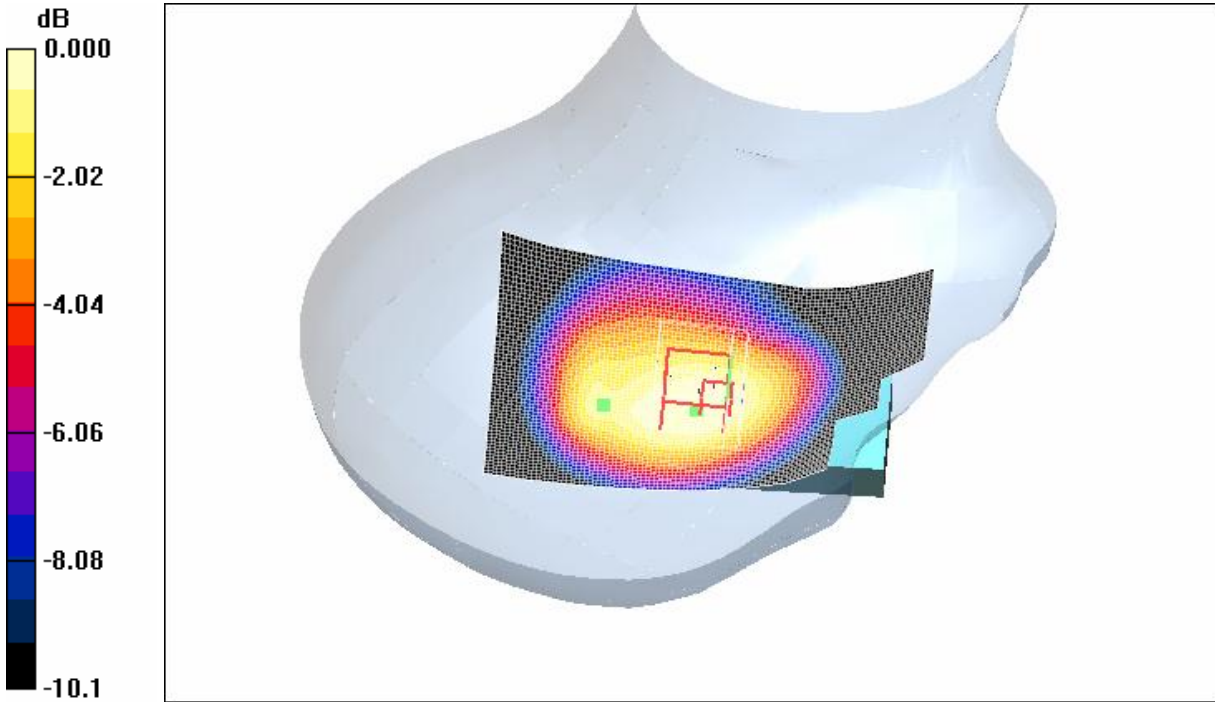

0 dB = 1.18mW/g

4.8RightHandSide-Cheek-GSM850-Middle

Date/Time: 2006-5-31 12:14:51

Test Laboratory: SGS-GSM

FCC-OET65-RightHandSide-Cheek-GSM850-Mid

DUT: GSM10000292E; Type: Head; Serial: 20060525

Communication System: GSM850-GSM Mode; Frequency: 836.4 MHz;Duty Cycle: 1:8.3

Medium: HSL850 Medium parameters used (interpolated): $f = 836.4$ MHz; $\sigma = 0.878$ mho/m; $\epsilon_r = 41.7$;

$\rho = 1000$ kg/m³

Phantom section: Right Section

Measurement Standard: DAS4 (High Precision Assessment)

DASY4 Configuration:

- Probe: ES3DV3 - SN3088; ConvF(5.91, 5.91, 5.91); Calibrated: 2005-9-13
- Sensor-Surface: 4mm (Mechanical Surface Detection)
- Electronics: DAE3 Sn569; Calibrated: 2005-11-17
- Phantom: SAM 12; Type: SAM V4.0; Serial: TP-1283
- Measurement SW: DASY4, V4.6 Build 23; Postprocessing SW: SEMCAD, V1.8 Build 160

Cheek position - Middle/Area Scan (61x101x1): Measurement grid: dx=15mm, dy=15mm

Maximum value of SAR (interpolated) = 0.891 mW/g

Cheek position - Middle/Zoom Scan (7x7x7)/Cube 0: Measurement grid: dx=5mm, dy=5mm, dz=5mm

Reference Value = 27.1 V/m; Power Drift = -0.093 dB

Peak SAR (extrapolated) = 1.09 W/kg

SAR(1 g) = 0.800 mW/g; SAR(10 g) = 0.576 mW/g

Maximum value of SAR (measured) = 0.859 mW/g

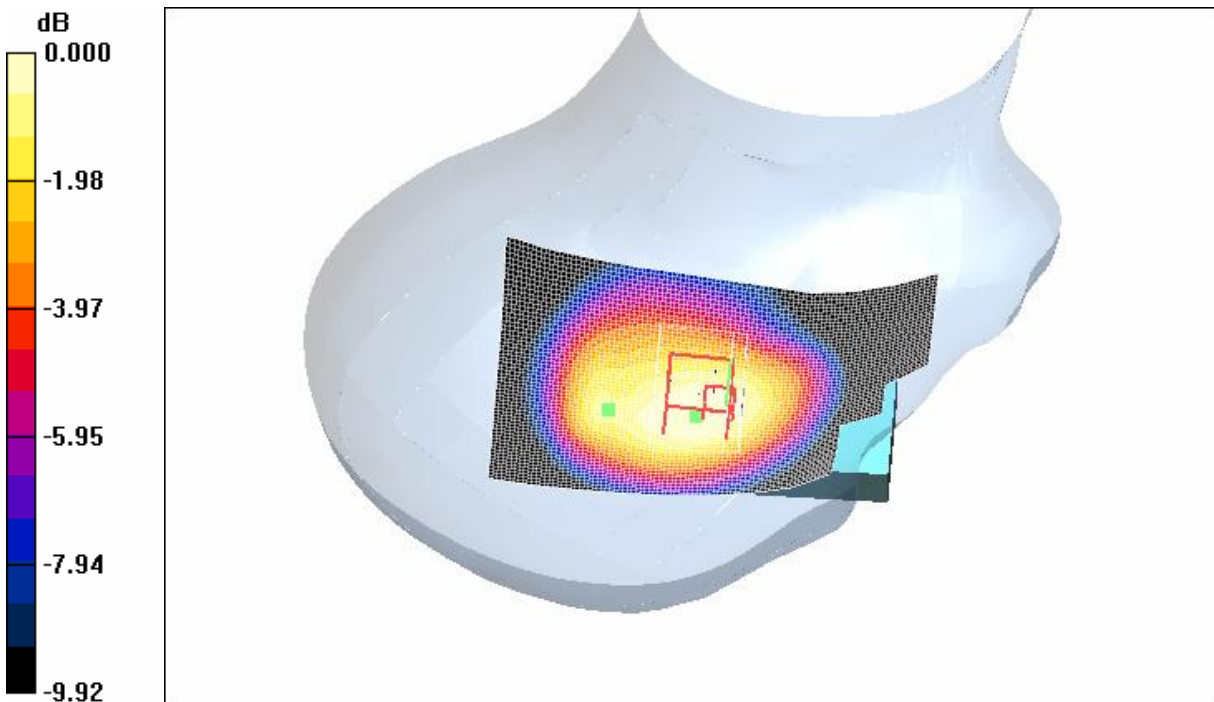

0 dB = 0.859mW/g

4.9RightHandSide-Cheek-GSM850-High

Date/Time: 2006-5-31 12:39:41

Test Laboratory: SGS-GSM

FCC-OET65-RightHandSide-Cheek-GSM850-High

DUT: GSM10000292E; Type: Head; Serial: 20060525

Communication System: GSM850-GSM Mode; Frequency: 848.8 MHz;Duty Cycle: 1:8.3

Medium: HSL850 Medium parameters used: $f = 849$ MHz; $\sigma = 0.89$ mho/m; $\epsilon_r = 41.6$; $\rho = 1000$ kg/m³

Phantom section: Right Section

Measurement Standard: DASYS4 (High Precision Assessment)

DASY4 Configuration:

- Probe: ES3DV3 - SN3088; ConvF(5.91, 5.91, 5.91); Calibrated: 2005-9-13
- Sensor-Surface: 4mm (Mechanical Surface Detection)
- Electronics: DAE3 Sn569; Calibrated: 2005-11-17
- Phantom: SAM 12; Type: SAM V4.0; Serial: TP-1283
- Measurement SW: DASYS4, V4.6 Build 23; Postprocessing SW: SEMCAD, V1.8 Build 160

Cheek position - High/Area Scan (61x101x1): Measurement grid: dx=15mm, dy=15mm

Maximum value of SAR (interpolated) = 0.576 mW/g

Cheek position - High/Zoom Scan (7x7x7) (7x7x7)/Cube 0: Measurement grid: dx=5mm, dy=5mm, dz=5mm

Reference Value = 21.5 V/m; Power Drift = 0.019 dB

Peak SAR (extrapolated) = 0.726 W/kg

SAR(1 g) = 0.525 mW/g; SAR(10 g) = 0.376 mW/g

Maximum value of SAR (measured) = 0.564 mW/g

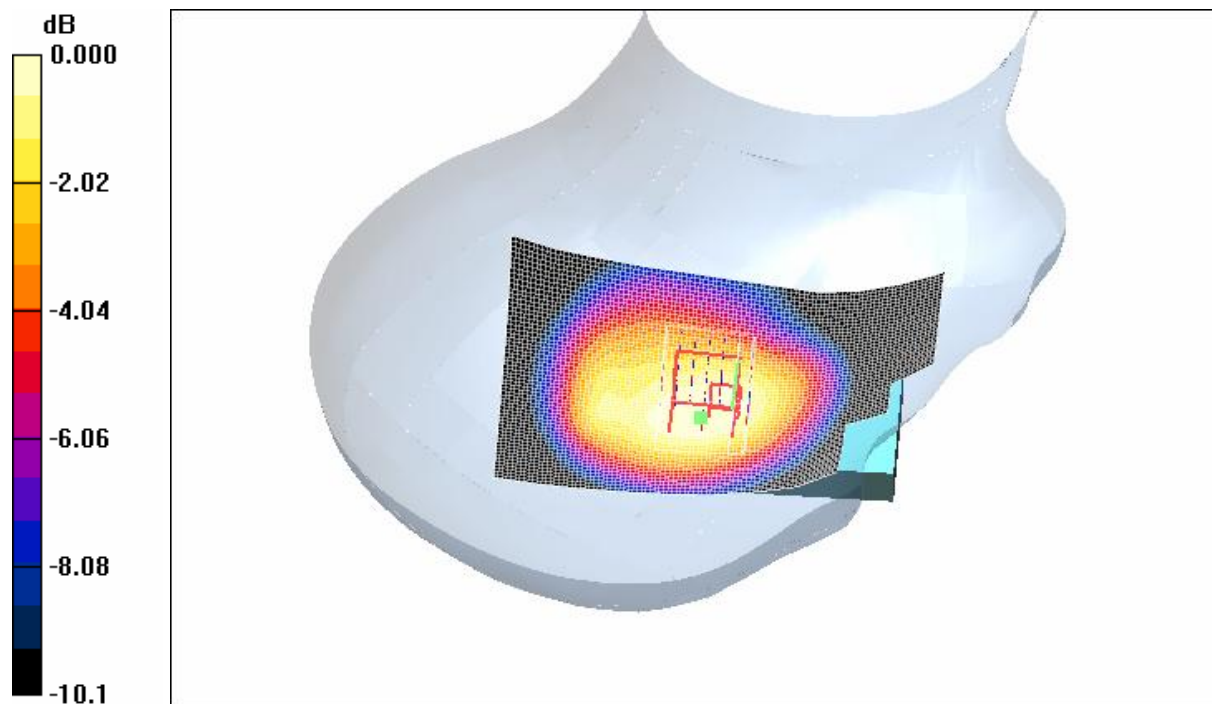

0 dB = 0.564mW/g

4.10RightHandSide-Tilt-GSM850-Low

Date/Time: 2006-5-31 13:10:11

Test Laboratory: SGS-GSM

FCC-OET65-RightHandSide-Tilt-GSM850-Low

DUT: GSM10000292E; Type: Head; Serial: 20060525

Communication System: GSM850-GSM Mode; Frequency: 824.2 MHz;Duty Cycle: 1:8.3

Medium: HSL850 Medium parameters used (interpolated): $f = 824.2$ MHz; $\sigma = 0.866$ mho/m; $\epsilon_r = 41.8$;

$\rho = 1000$ kg/m³

Phantom section: Right Section

Measurement Standard: DAS4 (High Precision Assessment)

DASY4 Configuration:

- Probe: ES3DV3 - SN3088; ConvF(5.91, 5.91, 5.91); Calibrated: 2005-9-13
- Sensor-Surface: 4mm (Mechanical Surface Detection)
- Electronics: DAE3 Sn569; Calibrated: 2005-11-17
- Phantom: SAM 12; Type: SAM V4.0; Serial: TP-1283
- Measurement SW: DASY4, V4.6 Build 23; Postprocessing SW: SEMCAD, V1.8 Build 160

Tilt position - Low/Area Scan (61x101x1): Measurement grid: dx=15mm, dy=15mm

Maximum value of SAR (interpolated) = 0.764 mW/g

Tilt position - Low/Zoom Scan (7x7x7) (7x7x7)/Cube 0: Measurement grid: dx=5mm, dy=5mm, dz=5mm

Reference Value = 29.3 V/m; Power Drift = -0.221 dB

Peak SAR (extrapolated) = 1.18 W/kg

SAR(1 g) = 0.713 mW/g; SAR(10 g) = 0.472 mW/g

Maximum value of SAR (measured) = 0.798 mW/g

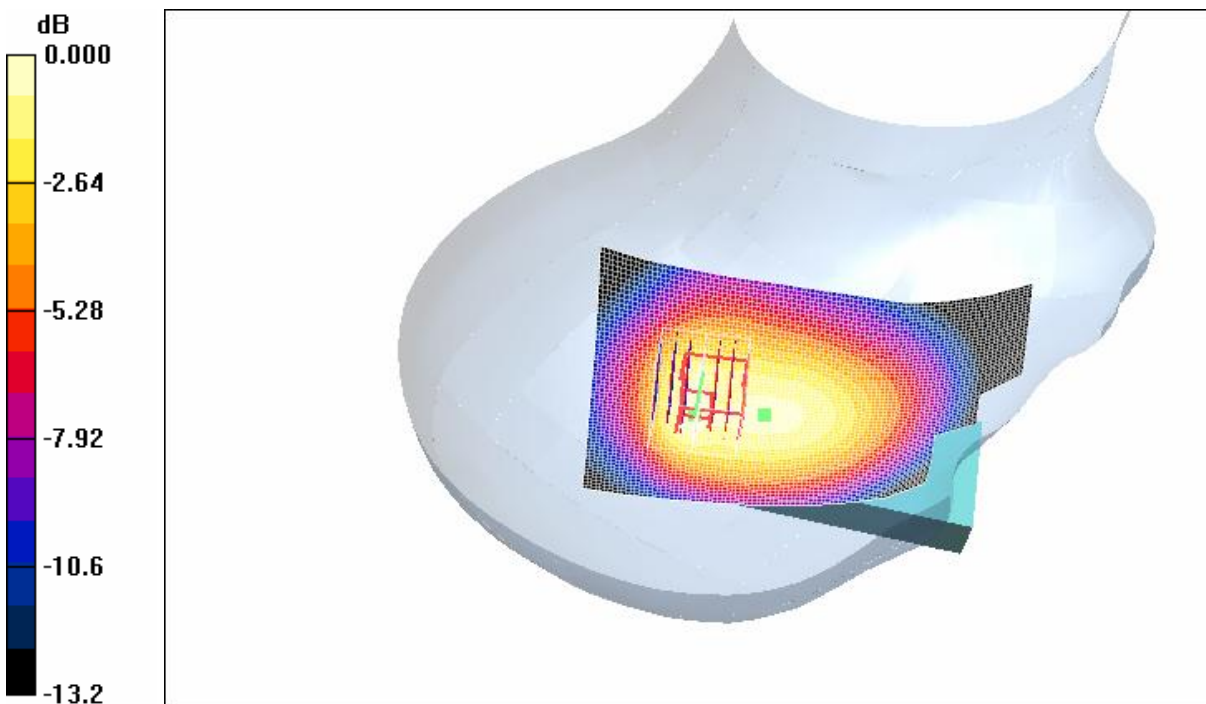

0 dB = 0.798mW/g

4.11RightHandSide-Tilt-GSM850-Middle

Date/Time: 2006-5-31 13:34:40

Test Laboratory: SGS-GSM

FCC-OET65-RightHandSide-Tilt-GSM850-Mid

DUT: GSM10000292E; Type: Head; Serial: 20060525

Communication System: GSM850-GSM Mode; Frequency: 836.4 MHz;Duty Cycle: 1:8.3

Medium: HSL850 Medium parameters used (interpolated): $f = 836.4$ MHz; $\sigma = 0.878$ mho/m; $\epsilon_r = 41.7$;
 $\rho = 1000$ kg/m³

Phantom section: Right Section

Measurement Standard: DASY4 (High Precision Assessment)

DASY4 Configuration:

- Probe: ES3DV3 - SN3088; ConvF(5.91, 5.91, 5.91); Calibrated: 2005-9-13
- Sensor-Surface: 4mm (Mechanical Surface Detection)
- Electronics: DAE3 Sn569; Calibrated: 2005-11-17
- Phantom: SAM 12; Type: SAM V4.0; Serial: TP-1283
- Measurement SW: DASY4, V4.6 Build 23; Postprocessing SW: SEMCAD, V1.8 Build 160

Tilt position - Middle/Area Scan (61x101x1): Measurement grid: dx=15mm, dy=15mm

Maximum value of SAR (interpolated) = 0.565 mW/g

Tilt position - Middle/Zoom Scan (7x7x7)/Cube 0: Measurement grid: dx=5mm, dy=5mm, dz=5mm

Reference Value = 24.8 V/m; Power Drift = -0.085 dB

Peak SAR (extrapolated) = 0.884 W/kg

SAR(1 g) = 0.525 mW/g; SAR(10 g) = 0.346 mW/g

Maximum value of SAR (measured) = 0.585 mW/g

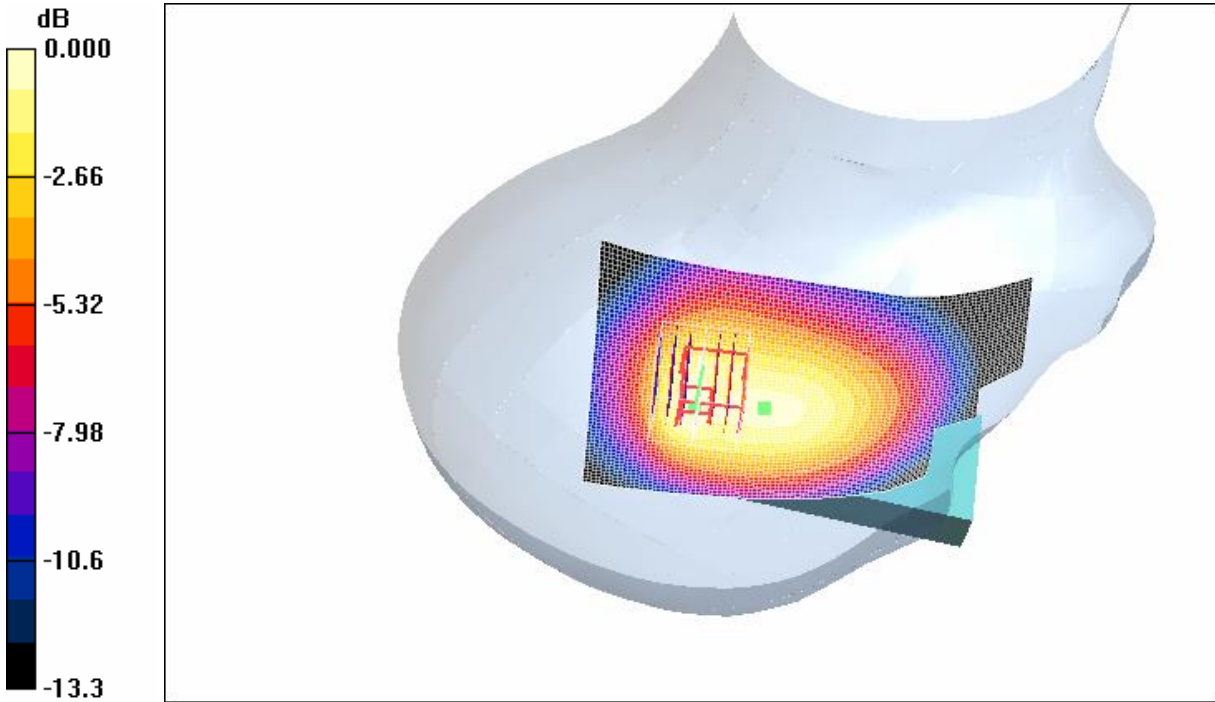

0 dB = 0.585mW/g

4.12 RightHandSide-Tilt-GSM850-High

Date/Time: 2006-6-1 15:31:01

Test Laboratory: SGS-GSM

FCC-OET65-RightHandSide-Tilt-GSM850-High

DUT: GSM10000292E; Type: Head; Serial: 20060525

Communication System: GSM850-GSM Mode; Frequency: 848.8 MHz; Duty Cycle: 1:8.3

Medium: HSL850 Medium parameters used: $f = 849$ MHz; $\sigma = 0.89$ mho/m; $\epsilon_r = 41.6$; $\rho = 1000$ kg/m³

Phantom section: Right Section

Measurement Standard: DASY4 (High Precision Assessment)

DASY4 Configuration:

- Probe: ES3DV3 - SN3088; ConvF(5.91, 5.91, 5.91); Calibrated: 2005-9-13

- Sensor-Surface: 4mm (Mechanical Surface Detection)
- Electronics: DAE3 Sn569; Calibrated: 2005-11-17
- Phantom: SAM 12; Type: SAM V4.0; Serial: TP-1283
- Measurement SW: DASY4, V4.6 Build 23; Postprocessing SW: SEMCAD, V1.8 Build 160

Tilt position - High/Area Scan (61x91x1): Measurement grid: dx=15mm, dy=15mm

Maximum value of SAR (interpolated) = 0.403 mW/g

Tilt position - High/Zoom Scan (7x7x7) (7x7x7)/Cube 0: Measurement grid: dx=5mm, dy=5mm, dz=5mm

Reference Value = 18.5 V/m; Power Drift = -0.117 dB

Peak SAR (extrapolated) = 0.558 W/kg

SAR(1 g) = 0.336 mW/g; SAR(10 g) = 0.220 mW/g

Maximum value of SAR (measured) = 0.369 mW/g

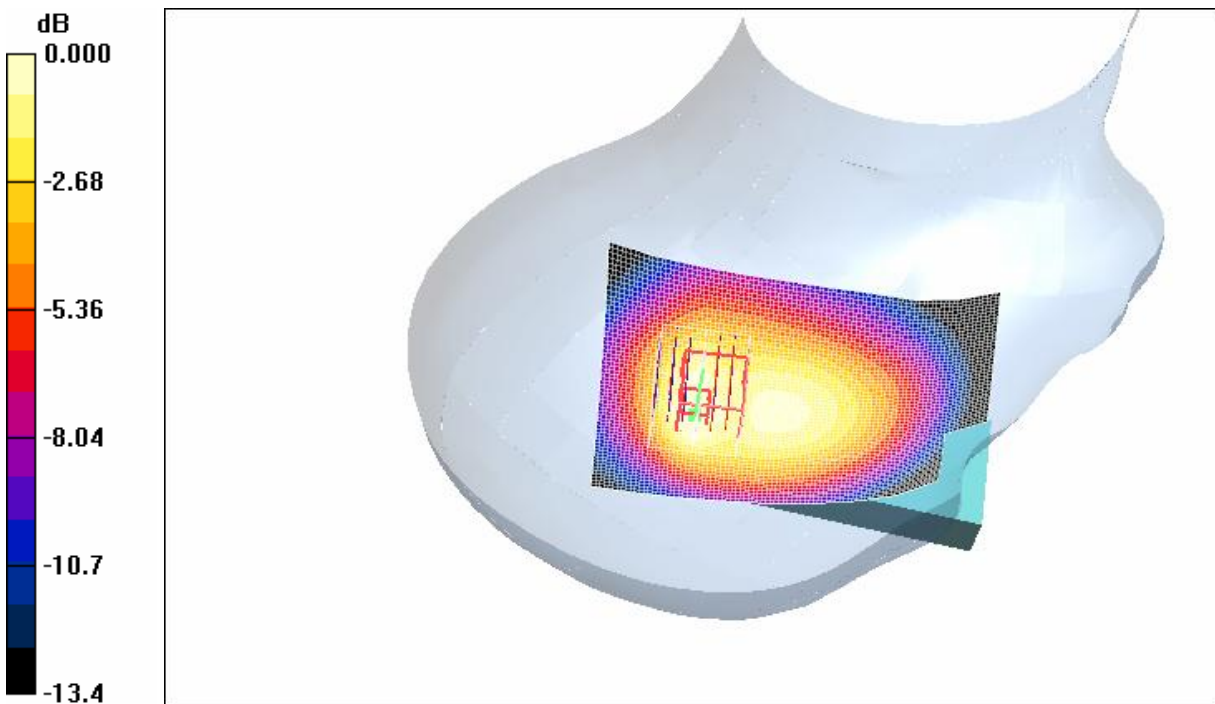

0 dB = 0.369mW/g

4.13 Body-Worn-GSM850-GPRS-Low

Date/Time: 2006-6-4 15:56:21

Test Laboratory: SGS-GSM

FCC-OET65-Body-Worn-GSM850-GPRS-Low-2cm

DUT: GSM10000292E; Type: Body; Serial: 20060525

Communication System: GSM850-GPRS Mode; Frequency: 824.2 MHz; Duty Cycle: 1:4

Medium: HSL850-Body Medium parameters used: $f = 824.2$ MHz; $\sigma = 0.984$ mho/m; $\epsilon_r = 52.6$; $\rho = 1000$ kg/m³

Phantom section: Flat Section

Measurement Standard: DAS4 (High Precision Assessment)

DAS4 Configuration:

- Probe: ES3DV3 - SN3088; ConvF(5.83, 5.83, 5.83); Calibrated: 2005-9-13
- Sensor-Surface: 4mm (Mechanical Surface Detection)
- Electronics: DAE3 Sn569; Calibrated: 2005-11-17
- Phantom: SAM 12; Type: SAM V4.0; Serial: TP-1283
- Measurement SW: DAS4, V4.6 Build 23; Postprocessing SW: SEMCAD, V1.8 Build 160

Body Worn - Low/Area Scan (51x91x1): Measurement grid: dx=15mm, dy=15mm

Maximum value of SAR (interpolated) = 1.08 mW/g

Body Worn - Low/Zoom Scan (7x7x7) (7x7x7)/Cube 0: Measurement grid: dx=5mm, dy=5mm, dz=5mm

Reference Value = 17.5 V/m; Power Drift = -0.308 dB

Peak SAR (extrapolated) = 1.39 W/kg

SAR(1 g) = 0.965 mW/g; SAR(10 g) = 0.672 mW/g

Maximum value of SAR (measured) = 1.02 mW/g

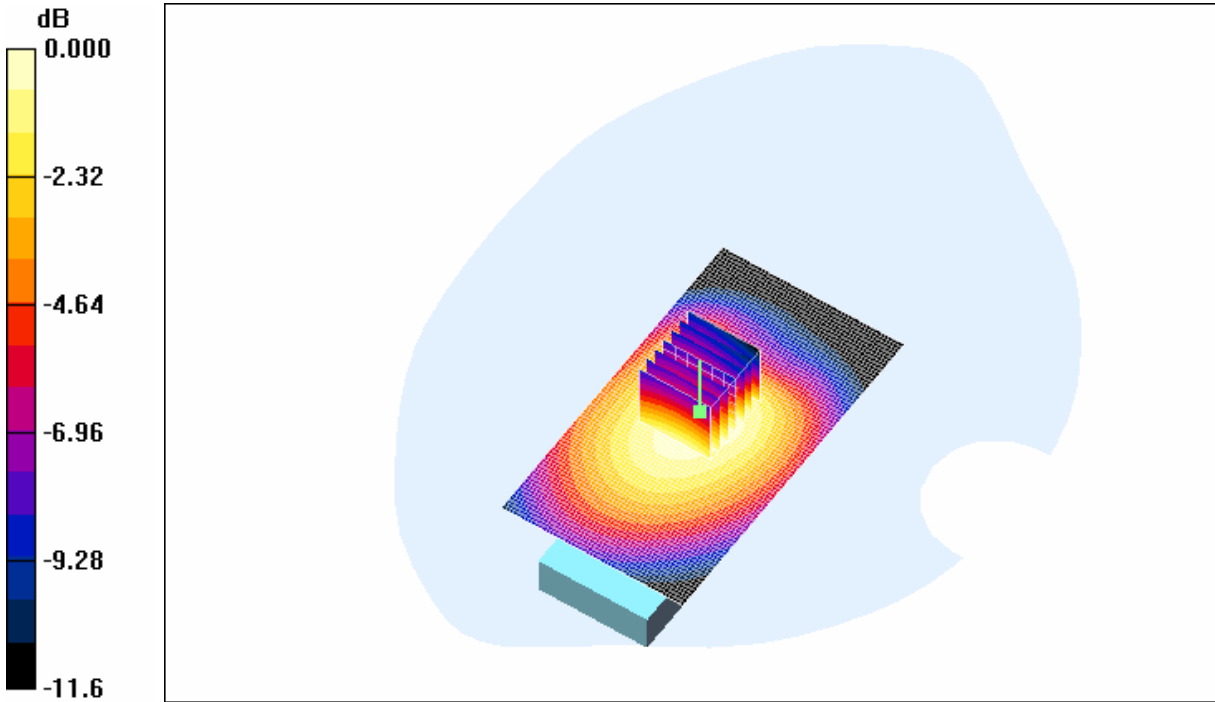

0 dB = 1.02mW/g

4.14 Body-Worn-GSM850-GPRS-Middle

Date/Time: 2006-6-4 16:29:46

Test Laboratory: SGS-GSM

FCC-OET65-Body-Worn-GSM850-GPRS-Mid-2cm

DUT: GSM10000292E; Type: Body; Serial: 20060525

Communication System: GSM850-GPRS Mode; Frequency: 836.4 MHz; Duty Cycle: 1:4

Medium: HSL850-Body Medium parameters used: $f = 836.4$ MHz; $\sigma = 0.998$ mho/m; $\epsilon_r = 52.5$; $\rho = 1000$ kg/m³

Phantom section: Flat Section

Measurement Standard: DASy4 (High Precision Assessment)

DASy4 Configuration:

- Probe: ES3DV3 - SN3088; ConvF(5.83, 5.83, 5.83); Calibrated: 2005-9-13
- Sensor-Surface: 4mm (Mechanical Surface Detection)
- Electronics: DAE3 Sn569; Calibrated: 2005-11-17
- Phantom: SAM 12; Type: SAM V4.0; Serial: TP-1283
- Measurement SW: DASY4, V4.6 Build 23; Postprocessing SW: SEMCAD, V1.8 Build 160

Body Worn - Middle/Area Scan (51x91x1): Measurement grid: dx=15mm, dy=15mm

Maximum value of SAR (interpolated) = 0.789 mW/g

Body Worn - Middle/Zoom Scan (7x7x7)/Cube 0: Measurement grid: dx=5mm, dy=5mm, dz=5mm

Reference Value = 14.7 V/m; Power Drift = -0.039 dB

Peak SAR (extrapolated) = 1.06 W/kg

SAR(1 g) = 0.729 mW/g; SAR(10 g) = 0.504 mW/g

Maximum value of SAR (measured) = 0.775 mW/g

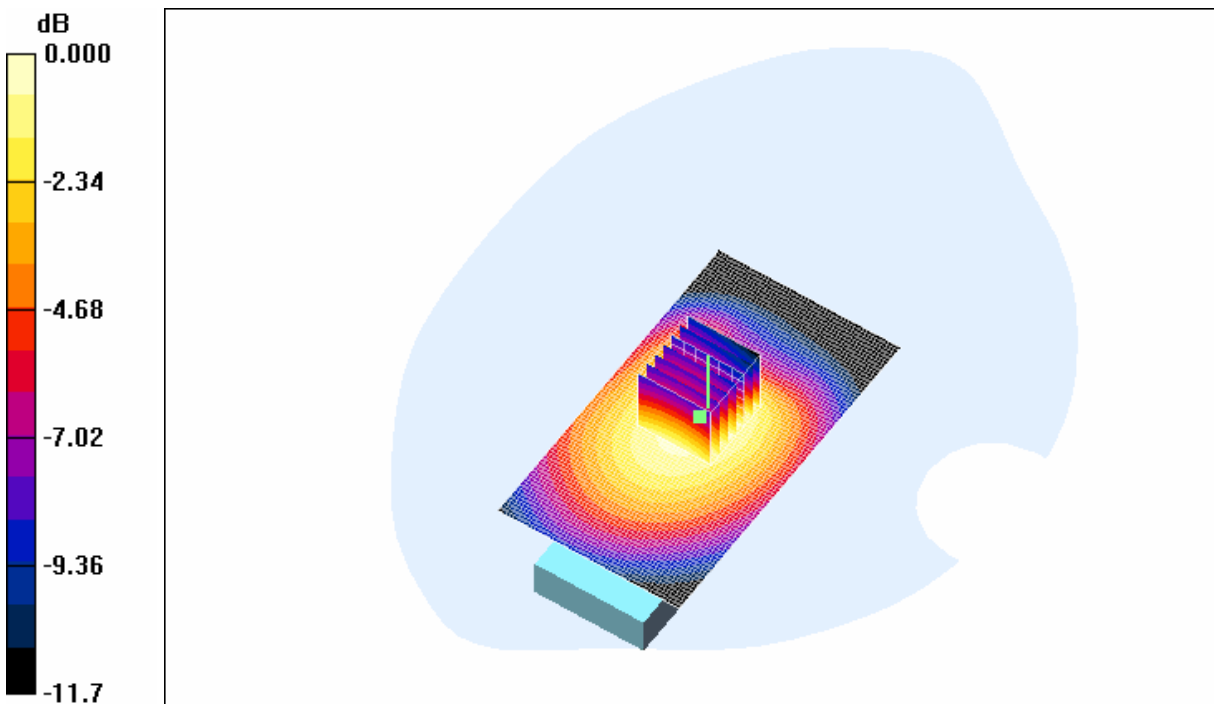

0 dB = 0.775mW/g

4.15 Body-Worn-GSM850-GPRS-High

Date/Time: 2006-6-4 16:54:54

Test Laboratory: SGS-GSM

FCC-OET65-Body-Worn-GSM850-GPRS-High-2cm

DUT: GSM10000292E; Type: Body; Serial: 20060525

Communication System: GSM850-GPRS Mode; Frequency: 848.8 MHz; Duty Cycle: 1:4

Medium: HSL850-Body Medium parameters used: $f = 848.8$ MHz; $\sigma = 1.01$ mho/m; $\epsilon_r = 52.5$; $\rho = 1000$ kg/m³

Phantom section: Flat Section

Measurement Standard: DASYS4 (High Precision Assessment)

DASY4 Configuration:

- Probe: ES3DV3 - SN3088; ConvF(5.83, 5.83, 5.83); Calibrated: 2005-9-13
- Sensor-Surface: 4mm (Mechanical Surface Detection)
- Electronics: DAE3 Sn569; Calibrated: 2005-11-17
- Phantom: SAM 12; Type: SAM V4.0; Serial: TP-1283
- Measurement SW: DASYS4, V4.6 Build 23; Postprocessing SW: SEMCAD, V1.8 Build 160

Body Worn - High/Area Scan (51x91x1): Measurement grid: dx=15mm, dy=15mm

Maximum value of SAR (interpolated) = 0.532 mW/g

Body Worn - High/Zoom Scan (7x7x7) (7x7x7)/Cube 0: Measurement grid: dx=5mm, dy=5mm, dz=5mm

Reference Value = 11.9 V/m; Power Drift = -0.042 dB

Peak SAR (extrapolated) = 0.704 W/kg

SAR(1 g) = 0.491 mW/g; SAR(10 g) = 0.341 mW/g

Maximum value of SAR (measured) = 0.522 mW/g

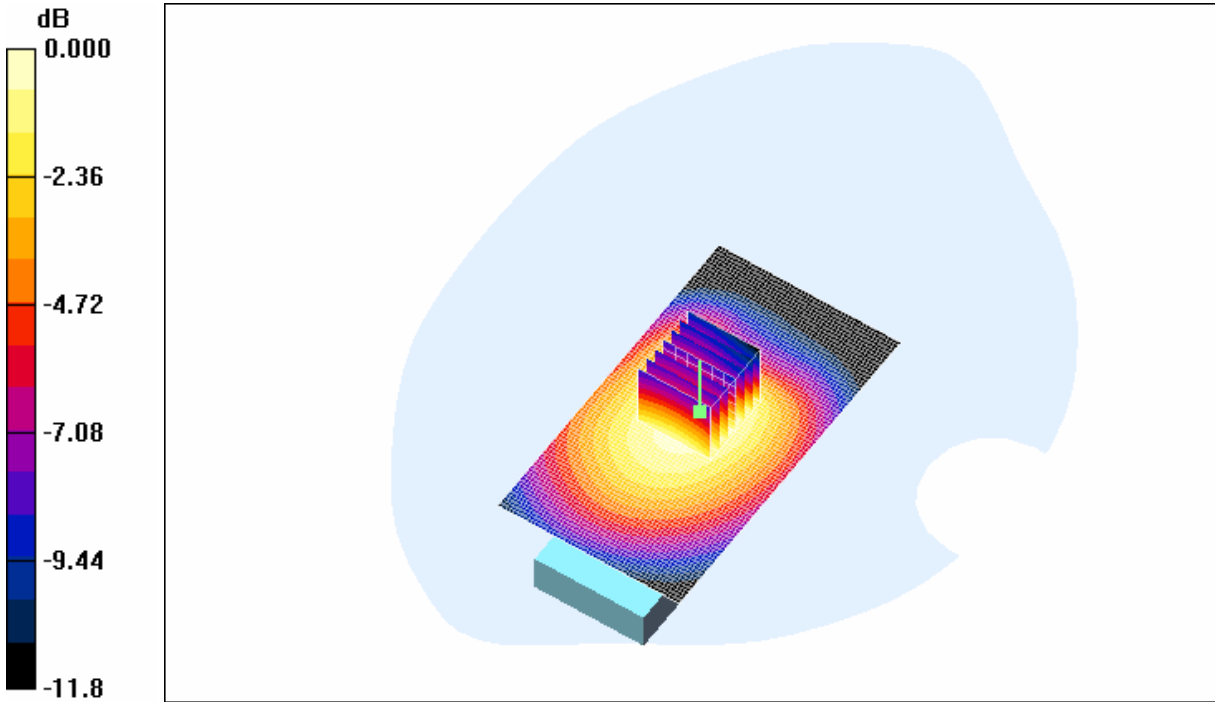

0 dB = 0.522mW/g

4.16LeftHandSide-Cheek-PCS1900-Low

Date/Time: 2006-6-8 8:47:51

Test Laboratory: SGS-GSM

FCC-OET65-LeftHandSide-Cheek-PCS1900-Low

DUT: GSM10000292E; Type: Head; Serial: 20060525

Communication System: PCS1900-GSM Mode; Frequency: 1850.2 MHz;Duty Cycle: 1:8.3

Medium: HSL1900 Medium parameters used: $f = 1850.2$ MHz; $\sigma = 1.42$ mho/m; $\epsilon_r = 40.5$; $\rho = 1000$ kg/m³

Phantom section: Left Section

Measurement Standard: DAS4 (High Precision Assessment)

DASY4 Configuration:

- Probe: ES3DV3 - SN3088; ConvF(4.93, 4.93, 4.93); Calibrated: 2005-9-13
- Sensor-Surface: 4mm (Mechanical Surface Detection)
- Electronics: DAE3 Sn569; Calibrated: 2005-11-17
- Phantom: SAM 12; Type: SAM V4.0; Serial: TP-1283
- Measurement SW: DASY4, V4.6 Build 23; Postprocessing SW: SEMCAD, V1.8 Build 160

Cheek position - Low/Area Scan (71x111x1): Measurement grid: dx=15mm, dy=15mm

Maximum value of SAR (interpolated) = 0.741 mW/g

Cheek position - Low/Zoom Scan (7x7x7) (7x7x7)/Cube 0: Measurement grid: dx=5mm, dy=5mm, dz=5mm

Reference Value = 19.9 V/m; Power Drift = -0.013 dB

Peak SAR (extrapolated) = 1.13 W/kg

SAR(1 g) = 0.635 mW/g; SAR(10 g) = 0.338 mW/g

Maximum value of SAR (measured) = 0.703 mW/g

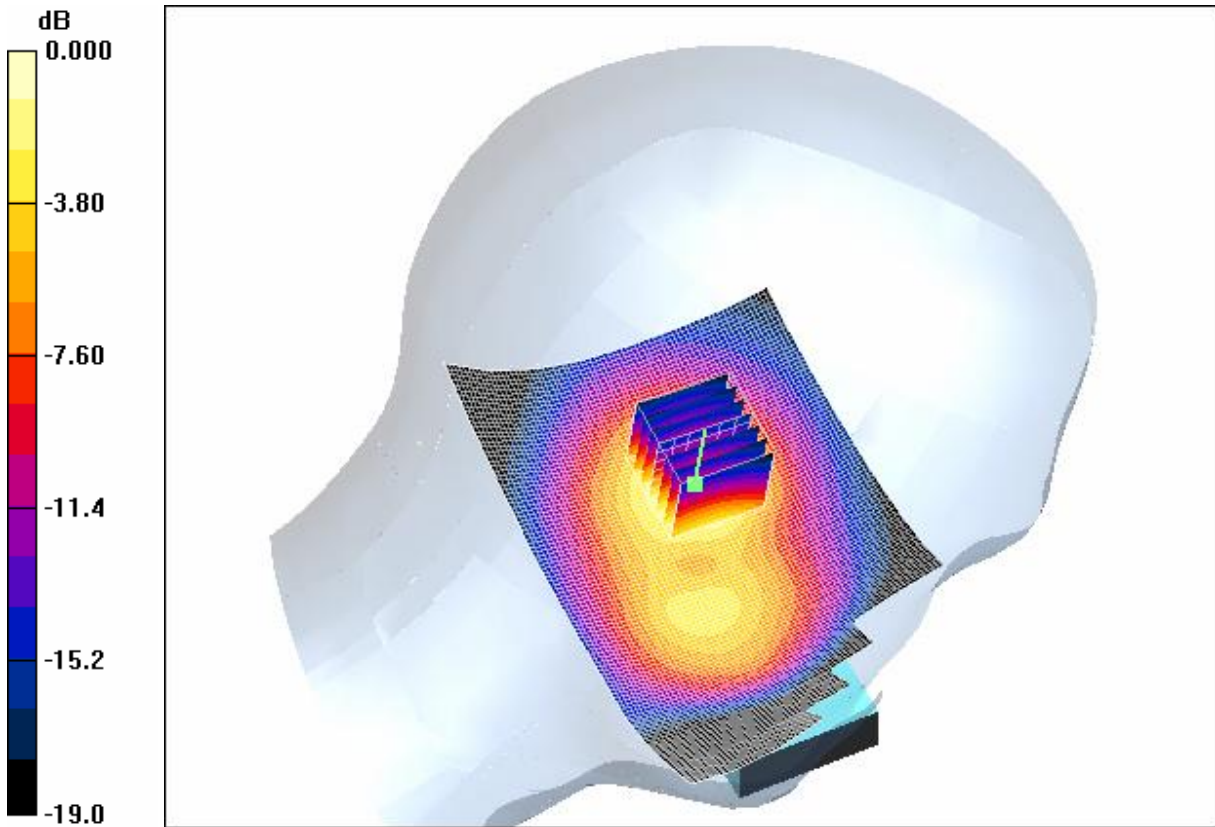

0 dB = 0.703mW/g

4.17LeftHandSide-Cheek-PCS1900-Middle

Date/Time: 2006-6-8 9:17:52

Test Laboratory: SGS-GSM

FCC-OET65-LeftHandSide-Cheek-PCS1900-Mid

DUT: GSM10000292E; Type: Head; Serial: 20060525

Communication System: PCS1900-GSM Mode; Frequency: 1880 MHz;Duty Cycle: 1:8.3

Medium: HSL1900 Medium parameters used: $f = 1880$ MHz; $\sigma = 1.44$ mho/m; $\epsilon_r = 40.3$; $\rho = 1000$ kg/m³

Phantom section: Left Section

Measurement Standard: DASYS4 (High Precision Assessment)

DASY4 Configuration:

- Probe: ES3DV3 - SN3088; ConvF(4.93, 4.93, 4.93); Calibrated: 2005-9-13
- Sensor-Surface: 4mm (Mechanical Surface Detection)
- Electronics: DAE3 Sn569; Calibrated: 2005-11-17
- Phantom: SAM 12; Type: SAM V4.0; Serial: TP-1283
- Measurement SW: DASYS4, V4.6 Build 23; Postprocessing SW: SEMCAD, V1.8 Build 160

Cheek position - Middle/Area Scan (71x111x1): Measurement grid: dx=15mm, dy=15mm

Maximum value of SAR (interpolated) = 0.782 mW/g

Cheek position - Middle/Zoom Scan (7x7x7)/Cube 0: Measurement grid: dx=5mm, dy=5mm,
dz=5mm

Reference Value = 20.4 V/m; Power Drift = -0.071 dB

Peak SAR (extrapolated) = 1.21 W/kg

SAR(1 g) = 0.671 mW/g; SAR(10 g) = 0.355 mW/g

Maximum value of SAR (measured) = 0.745 mW/g

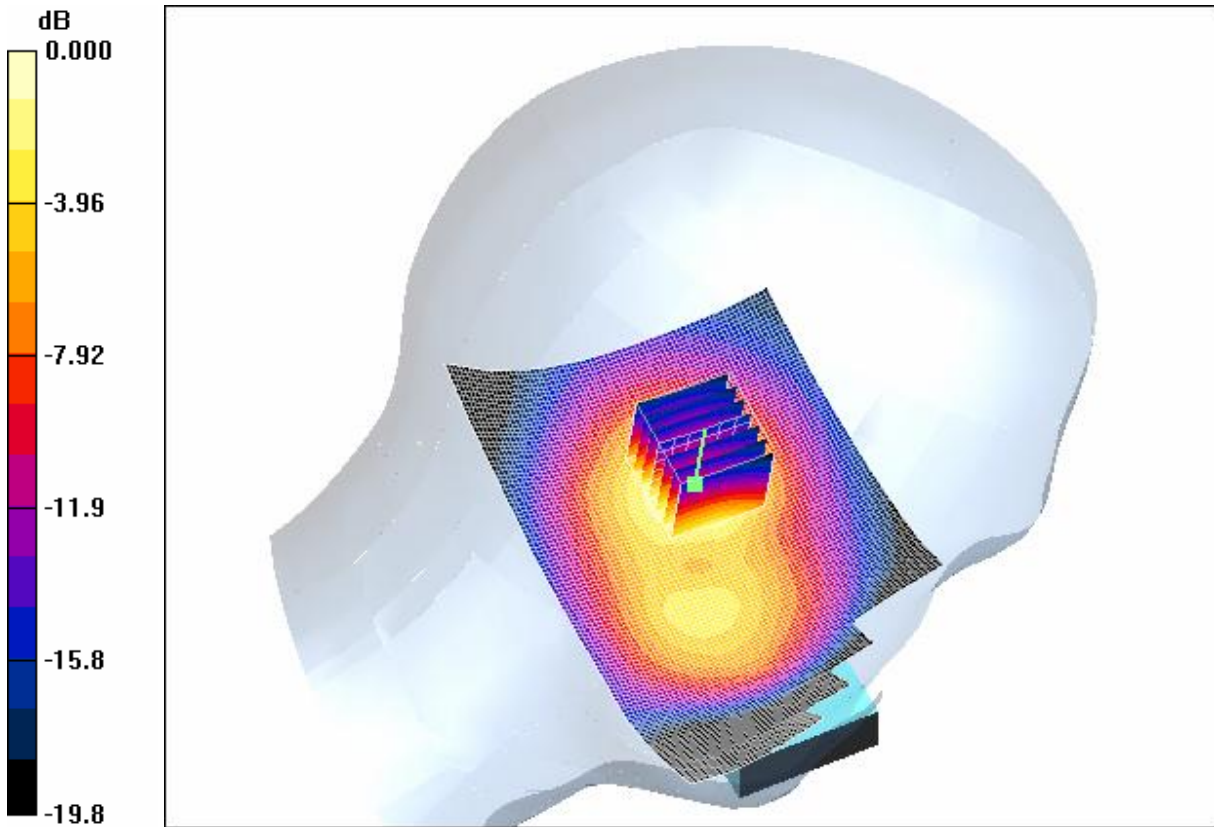

0 dB = 0.745mW/g

4.18LeftHandSide-Cheek-PCS1900-High

Date/Time: 2006-6-8 10:26:46

Test Laboratory: SGS-GSM

FCC-OET65-LeftHandSide-Cheek-PCS1900-High

DUT: GSM10000292E; Type: Head; Serial: 20060525

Communication System: PCS1900-GSM Mode; Frequency: 1909.8 MHz;Duty Cycle: 1:8.3

Medium: HSL1900 Medium parameters used: $f = 1909.8$ MHz; $\sigma = 1.47$ mho/m; $\epsilon_r = 40$; $\rho = 1000$ kg/m³

Phantom section: Left Section

Measurement Standard: DASYS4 (High Precision Assessment)

DASY4 Configuration:

- Probe: ES3DV3 - SN3088; ConvF(4.93, 4.93, 4.93); Calibrated: 2005-9-13
- Sensor-Surface: 4mm (Mechanical Surface Detection)
- Electronics: DAE3 Sn569; Calibrated: 2005-11-17
- Phantom: SAM 12; Type: SAM V4.0; Serial: TP-1283
- Measurement SW: DASYS4, V4.6 Build 23; Postprocessing SW: SEMCAD, V1.8 Build 160

Cheek position - High/Area Scan (71x111x1): Measurement grid: dx=15mm, dy=15mm

Maximum value of SAR (interpolated) = 0.796 mW/g

Cheek position - High/Zoom Scan (7x7x7) (7x7x7)/Cube 0: Measurement grid: dx=5mm, dy=5mm,
dz=5mm

Reference Value = 20.5 V/m; Power Drift = -0.142 dB

Peak SAR (extrapolated) = 1.25 W/kg

SAR(1 g) = 0.673 mW/g; SAR(10 g) = 0.349 mW/g

Maximum value of SAR (measured) = 0.746 mW/g

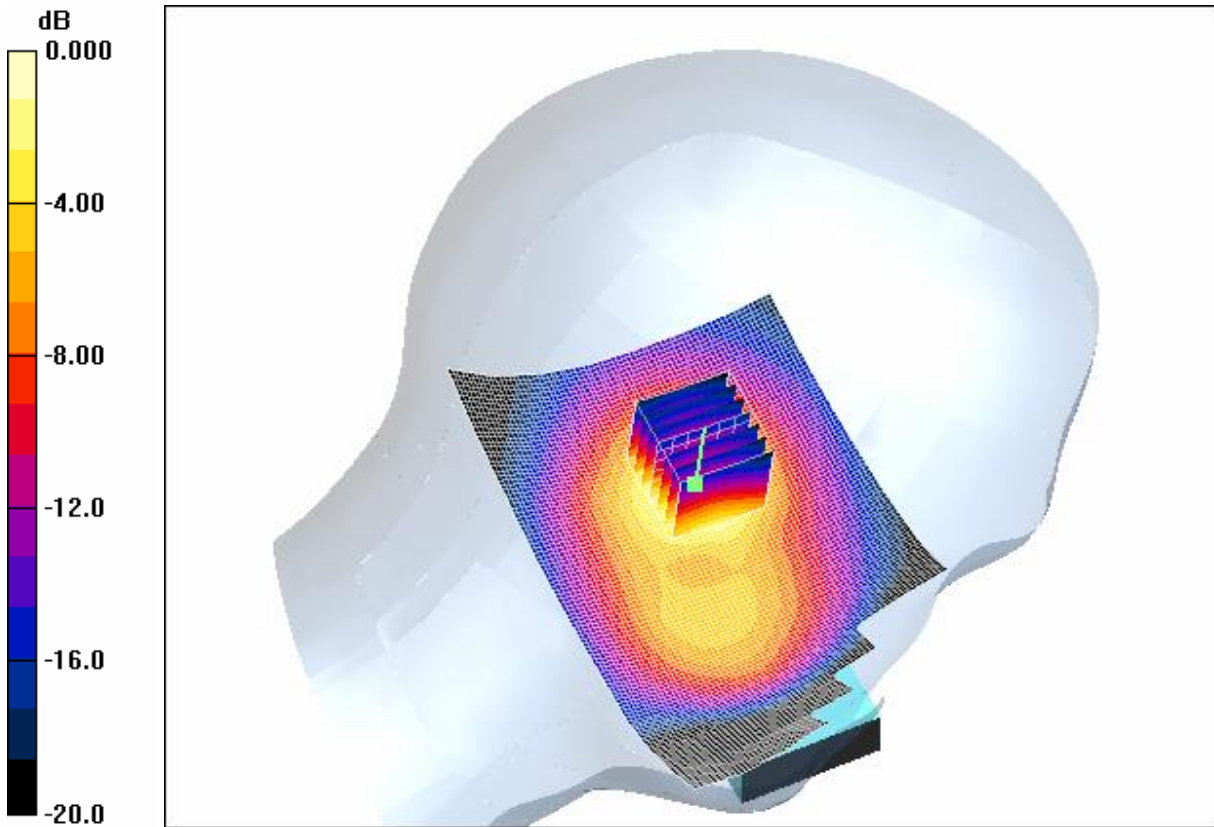

0 dB = 0.746mW/g

4.19LeftHandSide-Tilt-PCS1900-Low

Date/Time: 2006-6-8 10:57:14

Test Laboratory: SGS-GSM

FCC-OET65-LeftHandSide-Tilt-PCS1900-Low

DUT: GSM10000292E; Type: Head; Serial: 20060525

Communication System: PCS1900-GSM Mode; Frequency: 1850.2 MHz;Duty Cycle: 1:8.3

Medium: HSL1900 Medium parameters used: $f = 1850.2$ MHz; $\sigma = 1.42$ mho/m; $\epsilon_r = 40.5$; $\rho = 1000$ kg/m³

Phantom section: Left Section

Measurement Standard: DASYS4 (High Precision Assessment)

DASY4 Configuration:

- Probe: ES3DV3 - SN3088; ConvF(4.93, 4.93, 4.93); Calibrated: 2005-9-13
- Sensor-Surface: 4mm (Mechanical Surface Detection)
- Electronics: DAE3 Sn569; Calibrated: 2005-11-17
- Phantom: SAM 12; Type: SAM V4.0; Serial: TP-1283
- Measurement SW: DASYS4, V4.6 Build 23; Postprocessing SW: SEMCAD, V1.8 Build 160

Tilt position - Low/Area Scan (71x111x1): Measurement grid: dx=15mm, dy=15mm

Maximum value of SAR (interpolated) = 1.13 mW/g

Tilt position - Low/Zoom Scan (7x7x7) (7x7x7)/Cube 0: Measurement grid: dx=5mm, dy=5mm,
dz=5mm

Reference Value = 26.2 V/m; Power Drift = -0.015 dB

Peak SAR (extrapolated) = 1.75 W/kg

SAR(1 g) = 0.942 mW/g; SAR(10 g) = 0.497 mW/g

Maximum value of SAR (measured) = 1.04 mW/g

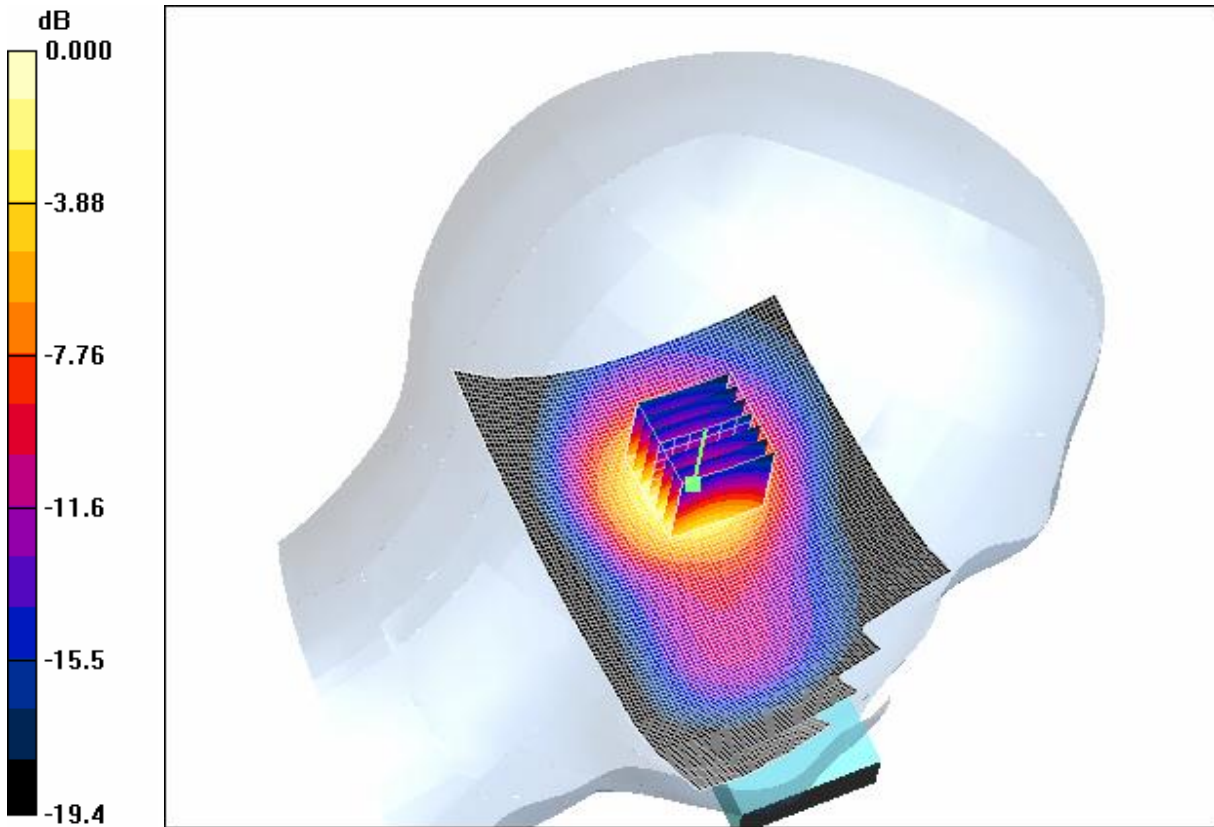

0 dB = 1.04mW/g

4.20LeftHandSide-Tilt-PCS1900-Middle

Date/Time: 2006-6-8 11:27:29

Test Laboratory: SGS-GSM

FCC-OET65-LeftHandSide-Tilt-PCS1900-Mid

DUT: GSM10000292E; Type: Head; Serial: 20060525

Communication System: PCS1900-GSM Mode; Frequency: 1880 MHz;Duty Cycle: 1:8.3

Medium: HSL1900 Medium parameters used: $f = 1880$ MHz; $\sigma = 1.44$ mho/m; $\epsilon_r = 40.3$; $\rho = 1000$ kg/m³

Phantom section: Left Section

Measurement Standard: DASYS4 (High Precision Assessment)

DASY4 Configuration:

- Probe: ES3DV3 - SN3088; ConvF(4.93, 4.93, 4.93); Calibrated: 2005-9-13
- Sensor-Surface: 4mm (Mechanical Surface Detection)
- Electronics: DAE3 Sn569; Calibrated: 2005-11-17
- Phantom: SAM 12; Type: SAM V4.0; Serial: TP-1283
- Measurement SW: DASYS4, V4.6 Build 23; Postprocessing SW: SEMCAD, V1.8 Build 160

Tilt position - Middle/Area Scan (71x111x1): Measurement grid: dx=15mm, dy=15mm

Maximum value of SAR (interpolated) = 1.20 mW/g

Tilt position - Middle/Zoom Scan (7x7x7)/Cube 0: Measurement grid: dx=5mm, dy=5mm, dz=5mm

Reference Value = 26.8 V/m; Power Drift = -0.042 dB

Peak SAR (extrapolated) = 1.86 W/kg

SAR(1 g) = 1 mW/g; SAR(10 g) = 0.525 mW/g

Maximum value of SAR (measured) = 1.12 mW/g

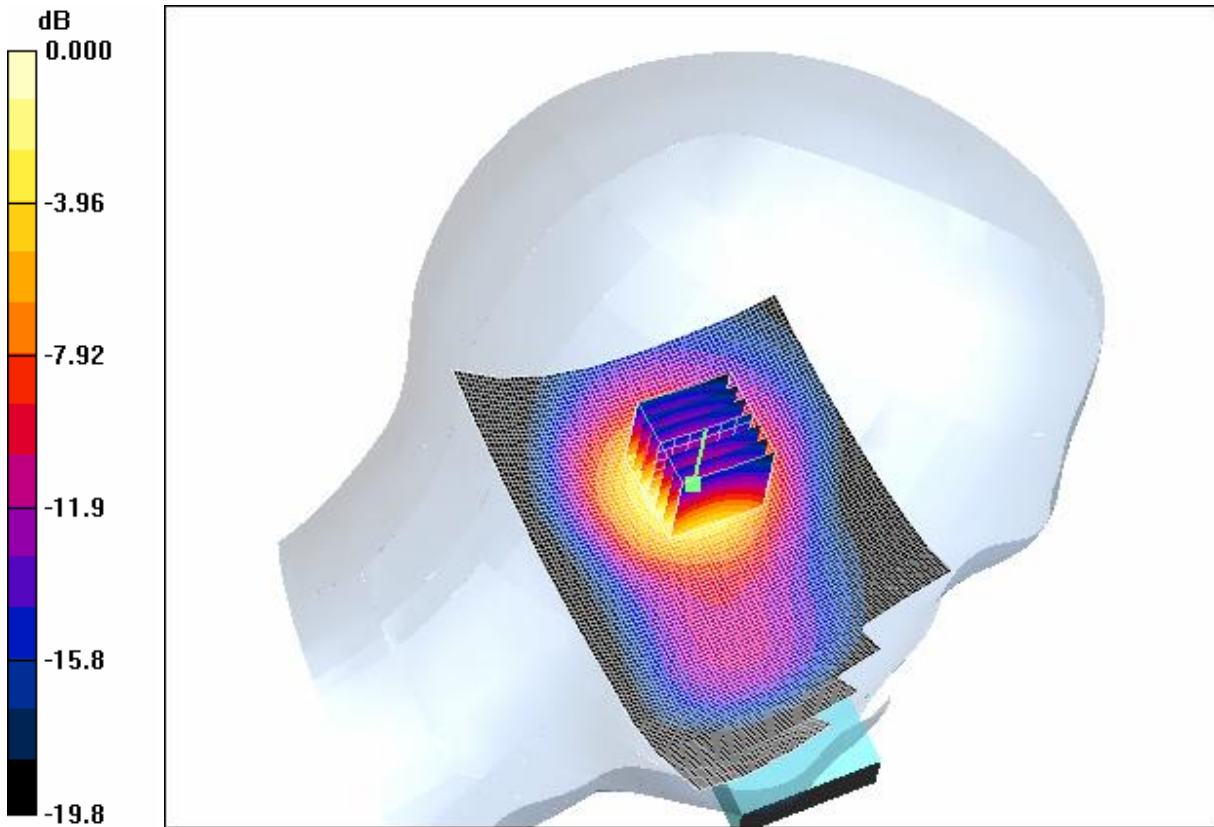

0 dB = 1.12mW/g

4.21LeftHandSide-Tilt-PCS1900-High

Date/Time: 2006-6-8 12:55:33

Test Laboratory: SGS-GSM

FCC-OET65-LeftHandSide-Tilt-PCS1900-High

DUT: GSM10000292E; Type: Head; Serial: 20060525

Communication System: PCS1900-GSM Mode; Frequency: 1909.8 MHz;Duty Cycle: 1:8.3

Medium: HSL1900 Medium parameters used: $f = 1909.8$ MHz; $\sigma = 1.47$ mho/m; $\epsilon_r = 40$; $\rho = 1000$ kg/m³

Phantom section: Left Section

Measurement Standard: DASYS4 (High Precision Assessment)

DASY4 Configuration:

- Probe: ES3DV3 - SN3088; ConvF(4.93, 4.93, 4.93); Calibrated: 2005-9-13
- Sensor-Surface: 4mm (Mechanical Surface Detection)
- Electronics: DAE3 Sn569; Calibrated: 2005-11-17
- Phantom: SAM 12; Type: SAM V4.0; Serial: TP-1283
- Measurement SW: DASYS4, V4.6 Build 23; Postprocessing SW: SEMCAD, V1.8 Build 160

Tilt position - High/Area Scan (71x111x1): Measurement grid: dx=15mm, dy=15mm

Maximum value of SAR (interpolated) = 0.928 mW/g

Tilt position - High/Zoom Scan (7x7x7) (7x7x7)/Cube 0: Measurement grid: dx=5mm, dy=5mm,
dz=5mm

Reference Value = 23.4 V/m; Power Drift = 0.007 dB

Peak SAR (extrapolated) = 1.50 W/kg

SAR(1 g) = 0.784 mW/g; SAR(10 g) = 0.409 mW/g

Maximum value of SAR (measured) = 0.871 mW/g

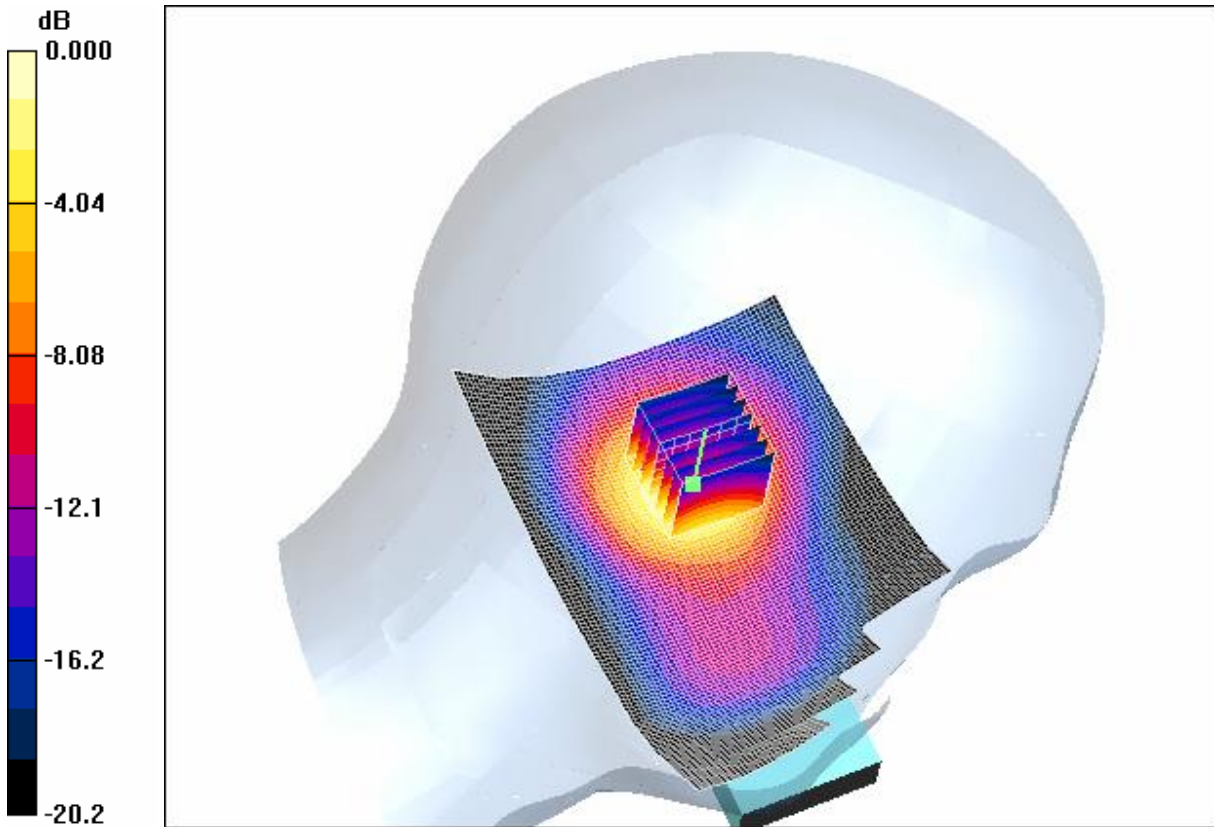

0 dB = 0.871mW/g

4.22RightHandSide-Cheek-PCS1900-Low

Date/Time: 2006-6-2 16:32:24

Test Laboratory: SGS-GSM

FCC-OET65-RightHandSide-Cheek-PCS1900-Low

DUT: GSM10000292E; Type: Head; Serial: 20060525

Communication System: PCS1900-GSM Mode; Frequency: 1850.2 MHz;Duty Cycle: 1:8.3

Medium: HSL1900 Medium parameters used: $f = 1850.2$ MHz; $\sigma = 1.42$ mho/m; $\epsilon_r = 40.5$; $\rho = 1000$ kg/m³

Phantom section: Right Section

Measurement Standard: DASYS4 (High Precision Assessment)

DASY4 Configuration:

- Probe: ES3DV3 - SN3088; ConvF(4.93, 4.93, 4.93); Calibrated: 2005-9-13
- Sensor-Surface: 4mm (Mechanical Surface Detection)
- Electronics: DAE3 Sn569; Calibrated: 2005-11-17
- Phantom: SAM 12; Type: SAM V4.0; Serial: TP-1283
- Measurement SW: DASYS4, V4.6 Build 23; Postprocessing SW: SEMCAD, V1.8 Build 160

Cheek position - Low/Area Scan (61x101x1): Measurement grid: dx=15mm, dy=15mm

Maximum value of SAR (interpolated) = 0.614 mW/g

Cheek position - Low/Zoom Scan (7x7x7) (7x7x7)/Cube 0: Measurement grid: dx=5mm, dy=5mm, dz=5mm

Reference Value = 20.4 V/m; Power Drift = -0.066 dB

Peak SAR (extrapolated) = 0.958 W/kg

SAR(1 g) = 0.553 mW/g; SAR(10 g) = 0.308 mW/g

Maximum value of SAR (measured) = 0.615 mW/g

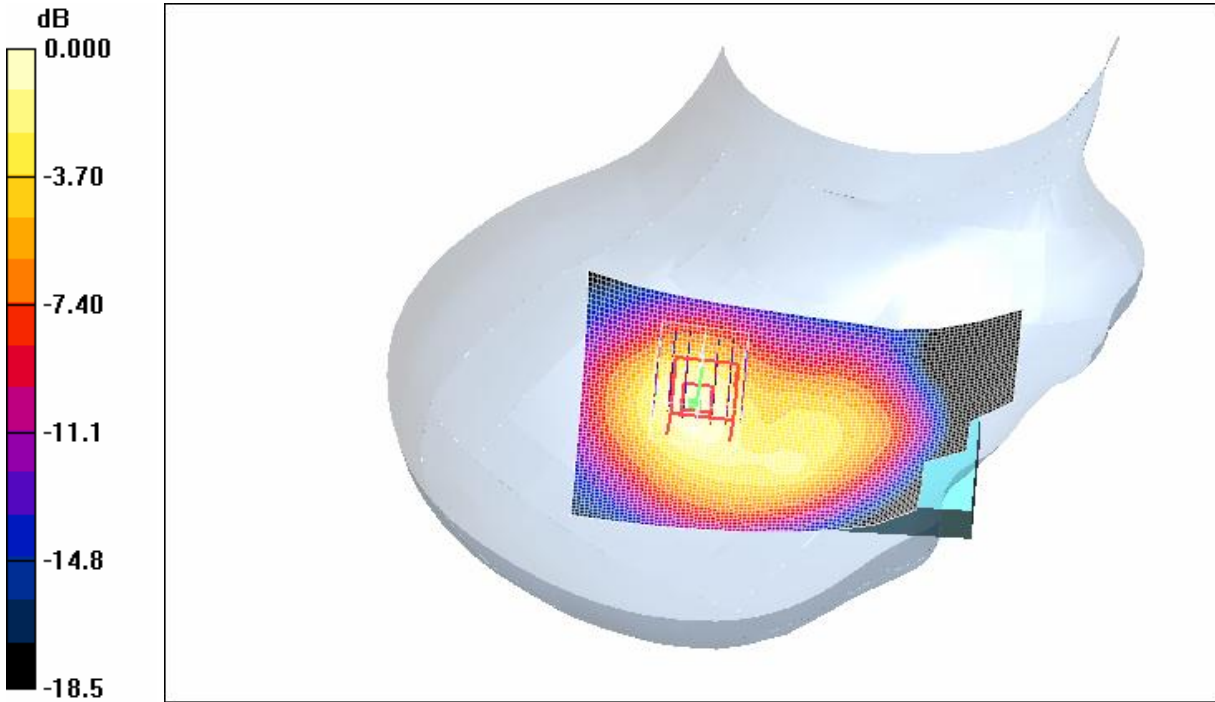

0 dB = 0.615mW/g

4.23RightHandSide-Cheek-PCS1900-Middle

Date/Time: 2006-6-2 17:02:59

Test Laboratory: SGS-GSM

FCC-OET65-RightHandSide-Cheek-PCS1900-Mid

DUT: GSM10000292E; Type: Head; Serial: 20060525

Communication System: PCS1900-GSM Mode; Frequency: 1880 MHz;Duty Cycle: 1:8.3

Medium: HSL1900 Medium parameters used: $f = 1880$ MHz; $\sigma = 1.44$ mho/m; $\epsilon_r = 40.3$; $\rho = 1000$ kg/m³

Phantom section: Right Section

Measurement Standard: DASY4 (High Precision Assessment)

DASY4 Configuration:

- Probe: ES3DV3 - SN3088; ConvF(4.93, 4.93, 4.93); Calibrated: 2005-9-13
- Sensor-Surface: 4mm (Mechanical Surface Detection)
- Electronics: DAE3 Sn569; Calibrated: 2005-11-17
- Phantom: SAM 12; Type: SAM V4.0; Serial: TP-1283
- Measurement SW: DASY4, V4.6 Build 23; Postprocessing SW: SEMCAD, V1.8 Build 160

Cheek position - Middle/Area Scan (61x101x1): Measurement grid: dx=15mm, dy=15mm

Maximum value of SAR (interpolated) = 0.634 mW/g

Cheek position - Middle/Zoom Scan (7x7x7)/Cube 0: Measurement grid: dx=5mm, dy=5mm, dz=5mm

Reference Value = 20.7 V/m; Power Drift = -0.126 dB

Peak SAR (extrapolated) = 1.01 W/kg

SAR(1 g) = 0.572 mW/g; SAR(10 g) = 0.315 mW/g

Maximum value of SAR (measured) = 0.630 mW/g

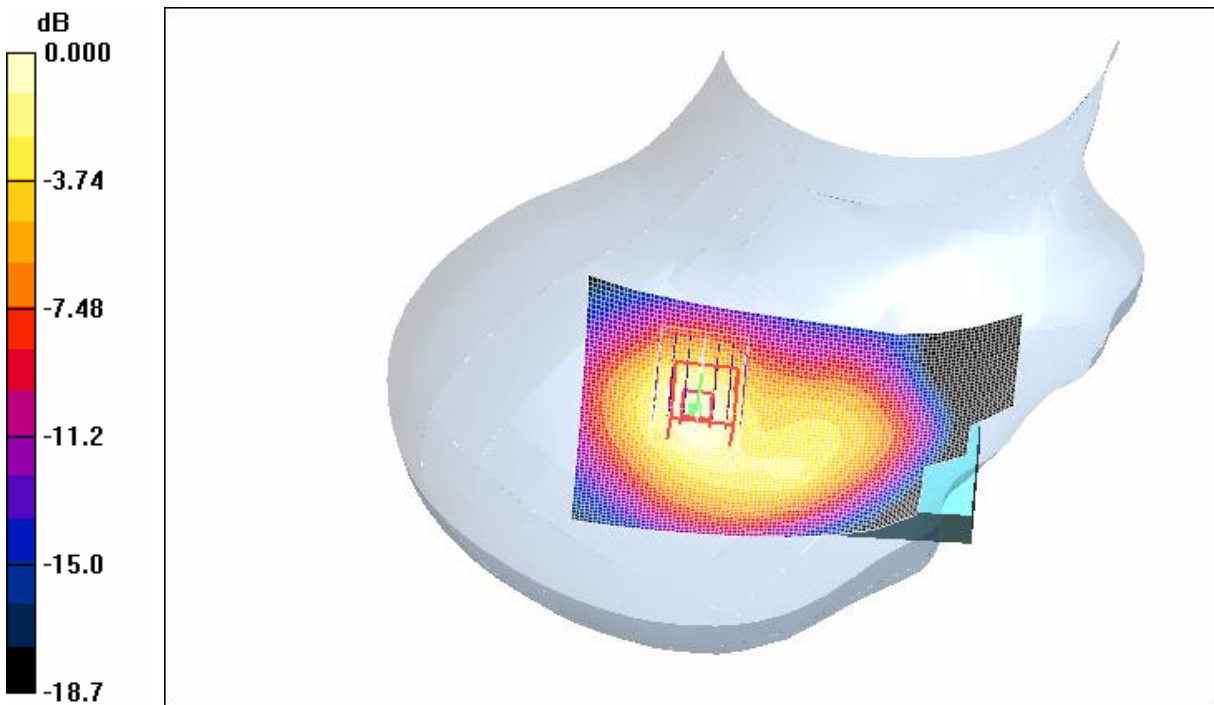

0 dB = 0.630mW/g

4.24RightHandSide-Cheek-PCS1900-High

Date/Time: 2006-6-2 18:25:03

Test Laboratory: SGS-GSM

FCC-OET65-RightHandSide-Cheek-PCS1900-High

DUT: GSM10000292E; Type: Head; Serial: 20060525

Communication System: PCS1900-GSM Mode; Frequency: 1909.8 MHz; Duty Cycle: 1:8.3

Medium: HSL1900 Medium parameters used: $f = 1909.8$ MHz; $\sigma = 1.47$ mho/m; $\epsilon_r = 40$; $\rho = 1000$ kg/m³

Phantom section: Right Section

Measurement Standard: DAS4 (High Precision Assessment)

DAS4 Configuration:

- Probe: ES3DV3 - SN3088; ConvF(4.93, 4.93, 4.93); Calibrated: 2005-9-13
- Sensor-Surface: 4mm (Mechanical Surface Detection)
- Electronics: DAE3 Sn569; Calibrated: 2005-11-17
- Phantom: SAM 12; Type: SAM V4.0; Serial: TP-1283
- Measurement SW: DAS4, V4.6 Build 23; Postprocessing SW: SEMCAD, V1.8 Build 160

Cheek position - High/Area Scan (61x101x1): Measurement grid: dx=15mm, dy=15mm

Maximum value of SAR (interpolated) = 0.588 mW/g

Cheek position - High/Zoom Scan (7x7x7) (7x7x7)/Cube 0: Measurement grid: dx=5mm, dy=5mm, dz=5mm

Reference Value = 19.5 V/m; Power Drift = -0.124 dB

Peak SAR (extrapolated) = 0.938 W/kg

SAR(1 g) = 0.525 mW/g; SAR(10 g) = 0.290 mW/g

Maximum value of SAR (measured) = 0.581 mW/g

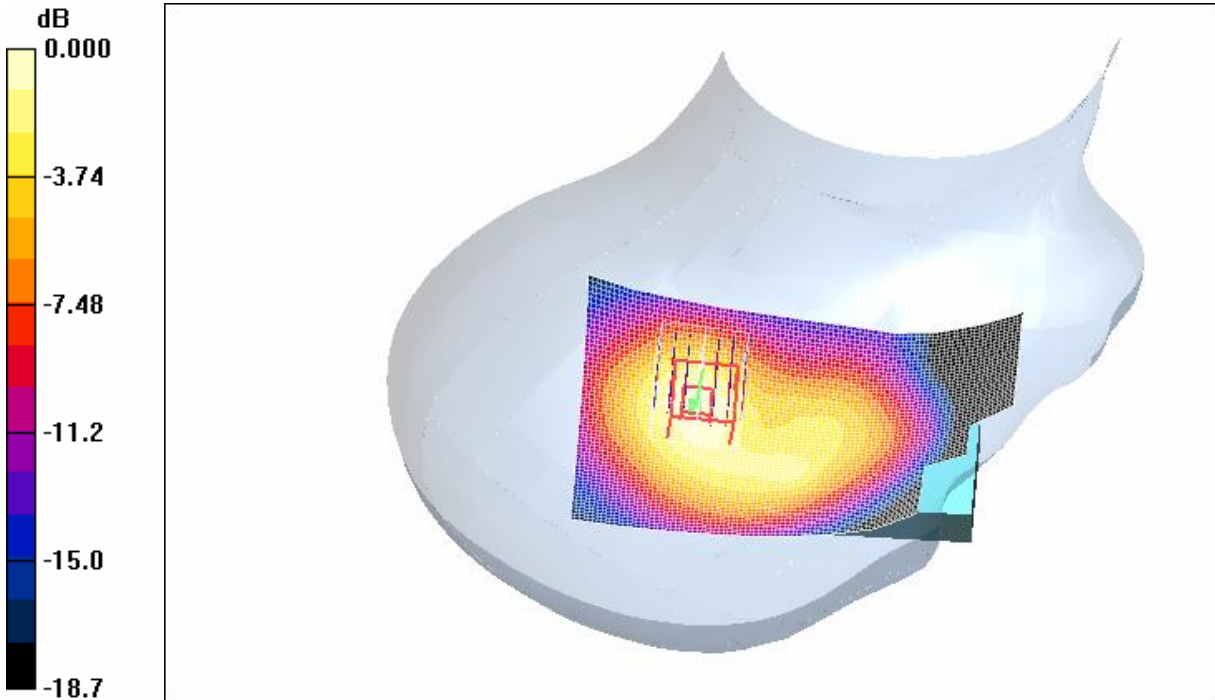

0 dB = 0.581mW/g

4.25RightHandSide-Tilt-PCS1900-Low

Date/Time: 2006-6-3 10:52:58

Test Laboratory: SGS-GSM

FCC-OET65-RightHandSide-Tilt-PCS1900-Low

DUT: GSM10000292E; Type: Head; Serial: 20060525

Communication System: PCS1900-GSM Mode; Frequency: 1850.2 MHz;Duty Cycle: 1:8.3

Medium: HSL1900 Medium parameters used: $f = 1850.2$ MHz; $\sigma = 1.42$ mho/m; $\epsilon_r = 40.5$; $\rho = 1000$ kg/m³

Phantom section: Right Section

Measurement Standard: DASY4 (High Precision Assessment)

DASY4 Configuration:

- Probe: ES3DV3 - SN3088; ConvF(4.93, 4.93, 4.93); Calibrated: 2005-9-13
- Sensor-Surface: 4mm (Mechanical Surface Detection)
- Electronics: DAE3 Sn569; Calibrated: 2005-11-17
- Phantom: SAM 12; Type: SAM V4.0; Serial: TP-1283
- Measurement SW: DASY4, V4.6 Build 23; Postprocessing SW: SEMCAD, V1.8 Build 160

Tilt position - Low/Area Scan (61x101x1): Measurement grid: dx=15mm, dy=15mm

Maximum value of SAR (interpolated) = 1.17 mW/g

Tilt position - Low/Zoom Scan (7x7x7) (7x7x7)/Cube 0: Measurement grid: dx=5mm, dy=5mm, dz=5mm

Reference Value = 27.7 V/m; Power Drift = -0.015 dB

Peak SAR (extrapolated) = 1.76 W/kg

SAR(1 g) = 0.994 mW/g; SAR(10 g) = 0.530 mW/g

Maximum value of SAR (measured) = 1.10 mW/g

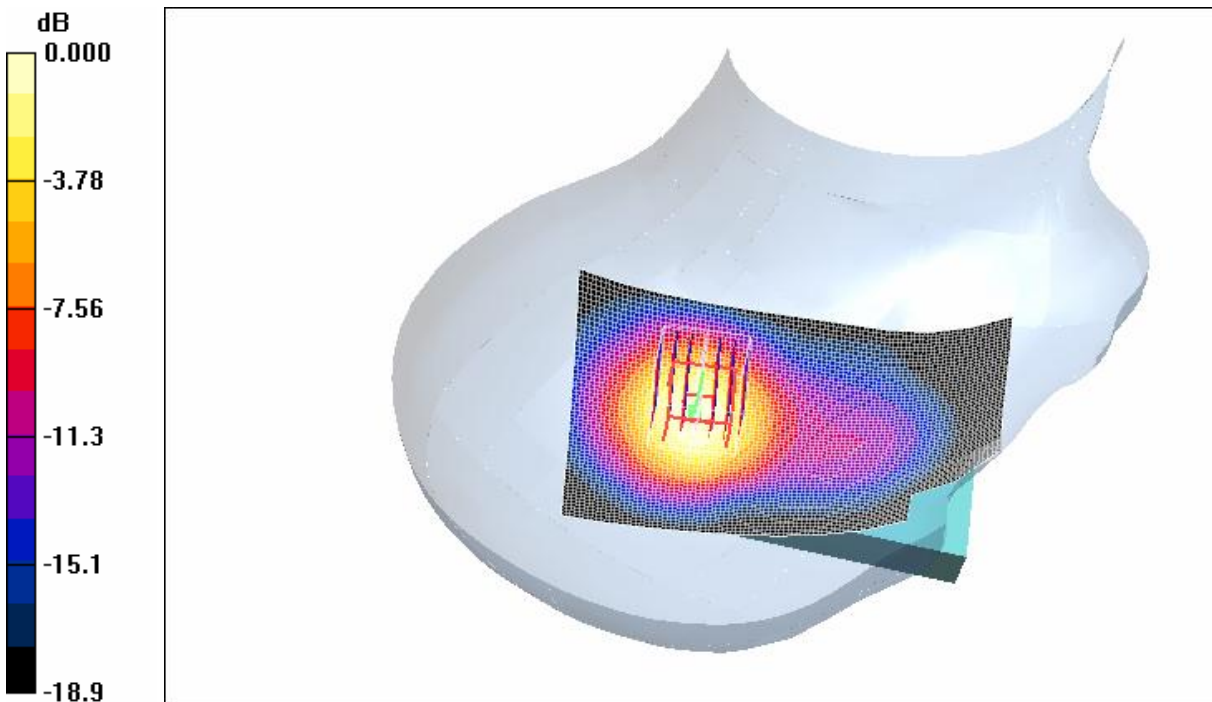

0 dB = 1.10mW/g

4.26RightHandSide-Tilt-PCS1900-Middle

Date/Time: 2006-6-3 11:24:01

Test Laboratory: SGS-GSM

FCC-OET65-RightHandSide-Tilt-PCS1900-Mid

DUT: GSM10000292E; Type: Head; Serial: 20060525

Communication System: PCS1900-GSM Mode; Frequency: 1880 MHz; Duty Cycle: 1:8.3

Medium: HSL1900 Medium parameters used: $f = 1880$ MHz; $\sigma = 1.44$ mho/m; $\epsilon_r = 40.3$; $\rho = 1000$ kg/m³

Phantom section: Right Section

Measurement Standard: DASY4 (High Precision Assessment)

DASY4 Configuration:

- Probe: ES3DV3 - SN3088; ConvF(4.93, 4.93, 4.93); Calibrated: 2005-9-13
- Sensor-Surface: 4mm (Mechanical Surface Detection)
- Electronics: DAE3 Sn569; Calibrated: 2005-11-17
- Phantom: SAM 12; Type: SAM V4.0; Serial: TP-1283
- Measurement SW: DASY4, V4.6 Build 23; Postprocessing SW: SEMCAD, V1.8 Build 160

Tilt position - Middle/Area Scan (61x101x1): Measurement grid: dx=15mm, dy=15mm

Maximum value of SAR (interpolated) = 1.22 mW/g

Tilt position - Middle/Zoom Scan (7x7x7)/Cube 0: Measurement grid: dx=5mm, dy=5mm, dz=5mm

Reference Value = 28.4 V/m; Power Drift = -0.032 dB

Peak SAR (extrapolated) = 1.88 W/kg

SAR(1 g) = 1.05 mW/g; SAR(10 g) = 0.560 mW/g

Maximum value of SAR (measured) = 1.17 mW/g

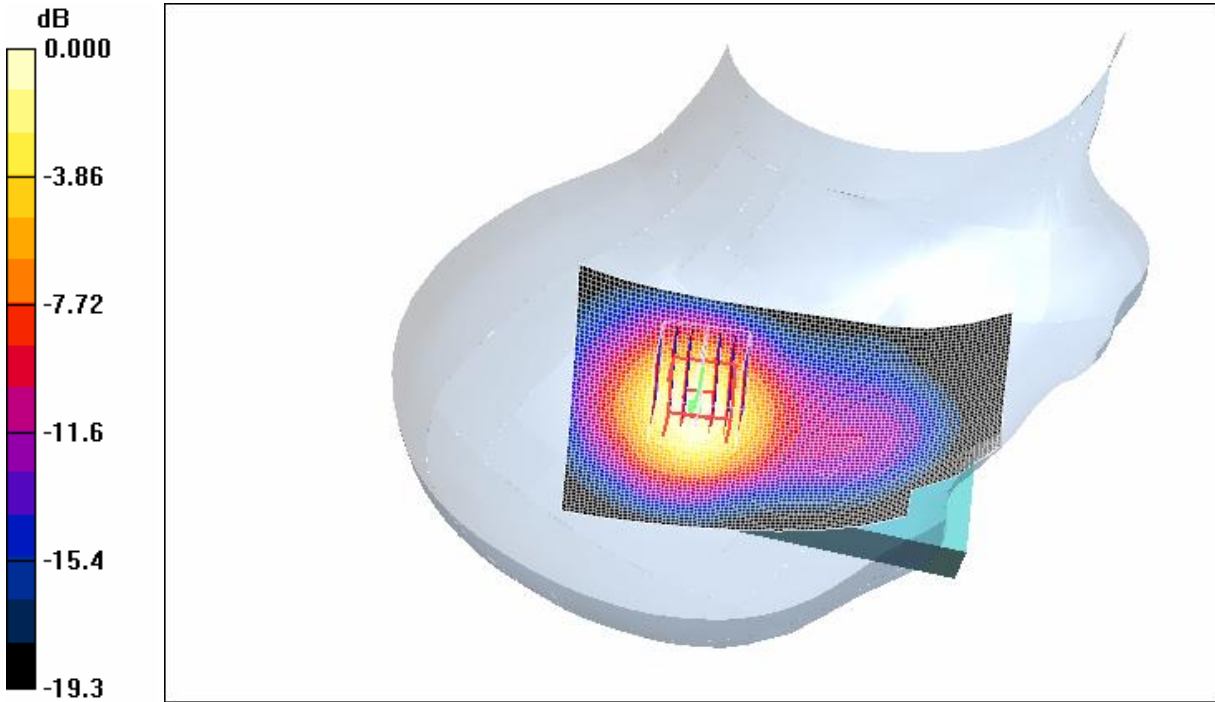

0 dB = 1.17mW/g

4.27RightHandSide-Tilt-PCS1900-High

Date/Time: 2006-6-3 11:55:03

Test Laboratory: SGS-GSM

FCC-OET65-RightHandSide-Tilt-PCS1900-High

DUT: GSM10000292E; Type: Head; Serial: 20060525

Communication System: PCS1900-GSM Mode; Frequency: 1909.8 MHz; Duty Cycle: 1:8.3

Medium: HSL1900 Medium parameters used: $f = 1909.8$ MHz; $\sigma = 1.47$ mho/m; $\epsilon_r = 40$; $\rho = 1000$ kg/m³

Phantom section: Right Section

Measurement Standard: DAS4 (High Precision Assessment)

DASY4 Configuration:

- Probe: ES3DV3 - SN3088; ConvF(4.93, 4.93, 4.93); Calibrated: 2005-9-13
- Sensor-Surface: 4mm (Mechanical Surface Detection)
- Electronics: DAE3 Sn569; Calibrated: 2005-11-17
- Phantom: SAM 12; Type: SAM V4.0; Serial: TP-1283
- Measurement SW: DASY4, V4.6 Build 23; Postprocessing SW: SEMCAD, V1.8 Build 160

Tilt position - High/Area Scan (61x101x1): Measurement grid: dx=15mm, dy=15mm

Maximum value of SAR (interpolated) = 1.05 mW/g

Tilt position - High/Zoom Scan (7x7x7) (7x7x7)/Cube 0: Measurement grid: dx=5mm, dy=5mm, dz=5mm

Reference Value = 25.8 V/m; Power Drift = -0.099 dB

Peak SAR (extrapolated) = 1.59 W/kg

SAR(1 g) = 0.881 mW/g; SAR(10 g) = 0.467 mW/g

Maximum value of SAR (measured) = 0.975 mW/g

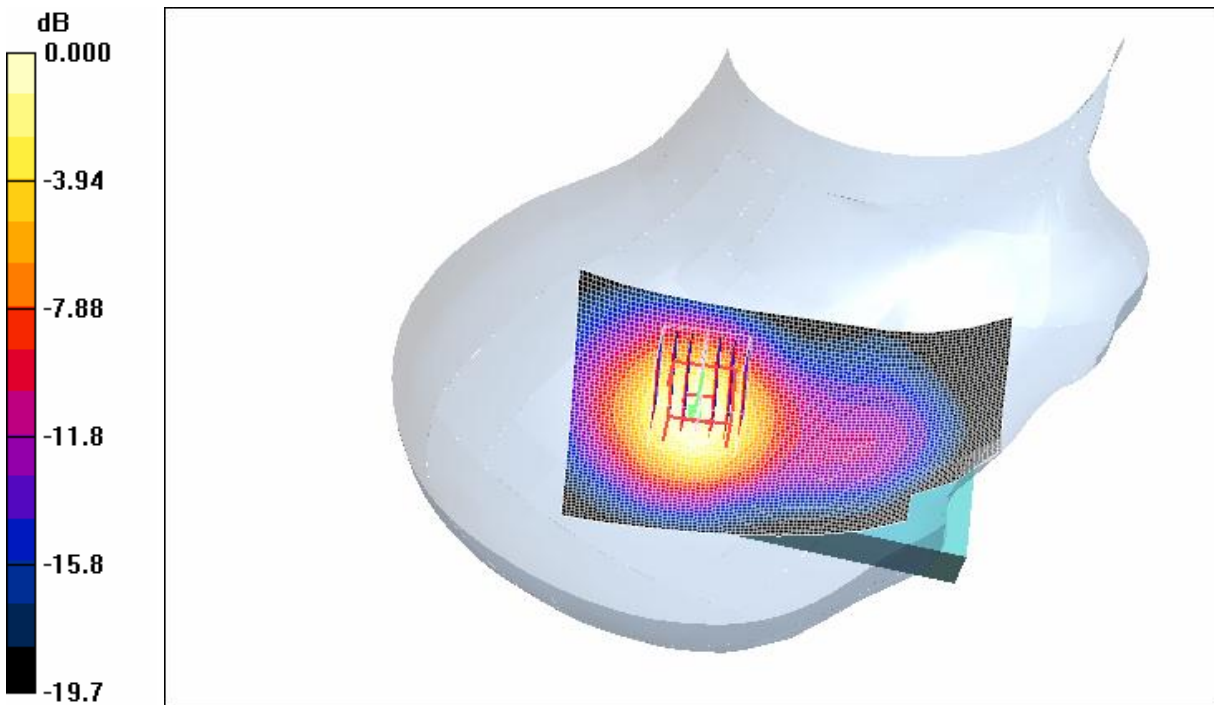

0 dB = 0.975mW/g

4.28 Body-Worn-PCS1900-GPRS-Low

Date/Time: 2006-5-30 15:09:39

Test Laboratory: SGS-GSM[

FCC-OET65-Body-Worn-PCS1900-GPRS-Low-2cm

DUT: GSM10000292E; Type: Body; Serial: 20060525

Communication System: PCS1900-GPRS Mode; Frequency: 1850.2 MHz; Duty Cycle: 1:4

Medium: HSL1900-Body Medium parameters used: $f = 1850.2$ MHz; $\sigma = 1.49$ mho/m; $\epsilon_r = 51.6$; $\rho = 1000$ kg/m³

Phantom section: Flat Section

Measurement Standard: DASY4 (High Precision Assessment)

DASY4 Configuration:

- Probe: ES3DV3 - SN3088; ConvF(4.53, 4.53, 4.53); Calibrated: 2005-9-13
- Sensor-Surface: 4mm (Mechanical Surface Detection)
- Electronics: DAE3 Sn569; Calibrated: 2005-11-17
- Phantom: SAM 12; Type: SAM V4.0; Serial: TP-1283
- Measurement SW: DASY4, V4.6 Build 23; Postprocessing SW: SEMCAD, V1.8 Build 160

Body Worn - Low/Area Scan (51x91x1): Measurement grid: dx=15mm, dy=15mm

Maximum value of SAR (interpolated) = 0.702 mW/g

Body Worn - Low/Zoom Scan (7x7x7) (7x7x7)/Cube 0: Measurement grid: dx=5mm, dy=5mm, dz=5mm

Reference Value = 19.0 V/m; Power Drift = -0.117 dB

Peak SAR (extrapolated) = 1.07 W/kg

SAR(1 g) = 0.628 mW/g; SAR(10 g) = 0.361 mW/g

Maximum value of SAR (measured) = 0.680 mW/g

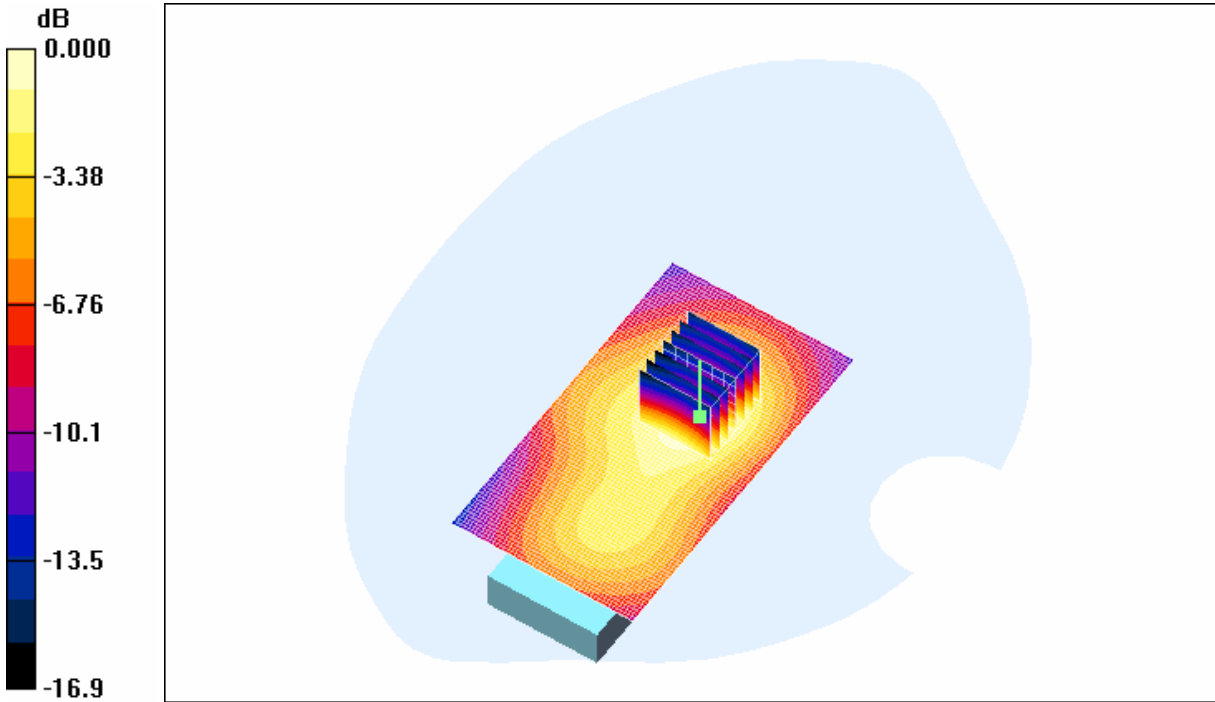

0 dB = 0.680mW/g

4.29Body-Worn-PCS1900-GPRS-Middle

Date/Time: 2006-5-30 15:32:23

Test Laboratory: SGS-GSM

FCC-OET65-Body-Worn-PCS1900-GPRS-Mid-2cm

DUT: GSM10000292E; Type: Body; Serial: 20060525

Communication System: PCS1900-GPRS Mode; Frequency: 1880 MHz;Duty Cycle: 1:4

Medium: HSL1900-Body Medium parameters used: $f = 1880$ MHz; $\sigma = 1.52$ mho/m; $\epsilon_r = 51.5$; $\rho = 1000$ kg/m³

Phantom section: Flat Section

Measurement Standard: DAS4 (High Precision Assessment)

DASY4 Configuration:

- Probe: ES3DV3 - SN3088; ConvF(4.53, 4.53, 4.53); Calibrated: 2005-9-13
- Sensor-Surface: 4mm (Mechanical Surface Detection)
- Electronics: DAE3 Sn569; Calibrated: 2005-11-17
- Phantom: SAM 12; Type: SAM V4.0; Serial: TP-1283
- Measurement SW: DASY4, V4.6 Build 23; Postprocessing SW: SEMCAD, V1.8 Build 160

Body Worn - Middle/Area Scan (51x91x1): Measurement grid: dx=15mm, dy=15mm

Maximum value of SAR (interpolated) = 0.630 mW/g

Body Worn - Middle/Zoom Scan (7x7x7)/Cube 0: Measurement grid: dx=5mm, dy=5mm, dz=5mm

Reference Value = 18.6 V/m; Power Drift = -0.096 dB

Peak SAR (extrapolated) = 0.977 W/kg

SAR(1 g) = 0.574 mW/g; SAR(10 g) = 0.330 mW/g

Maximum value of SAR (measured) = 0.620 mW/g

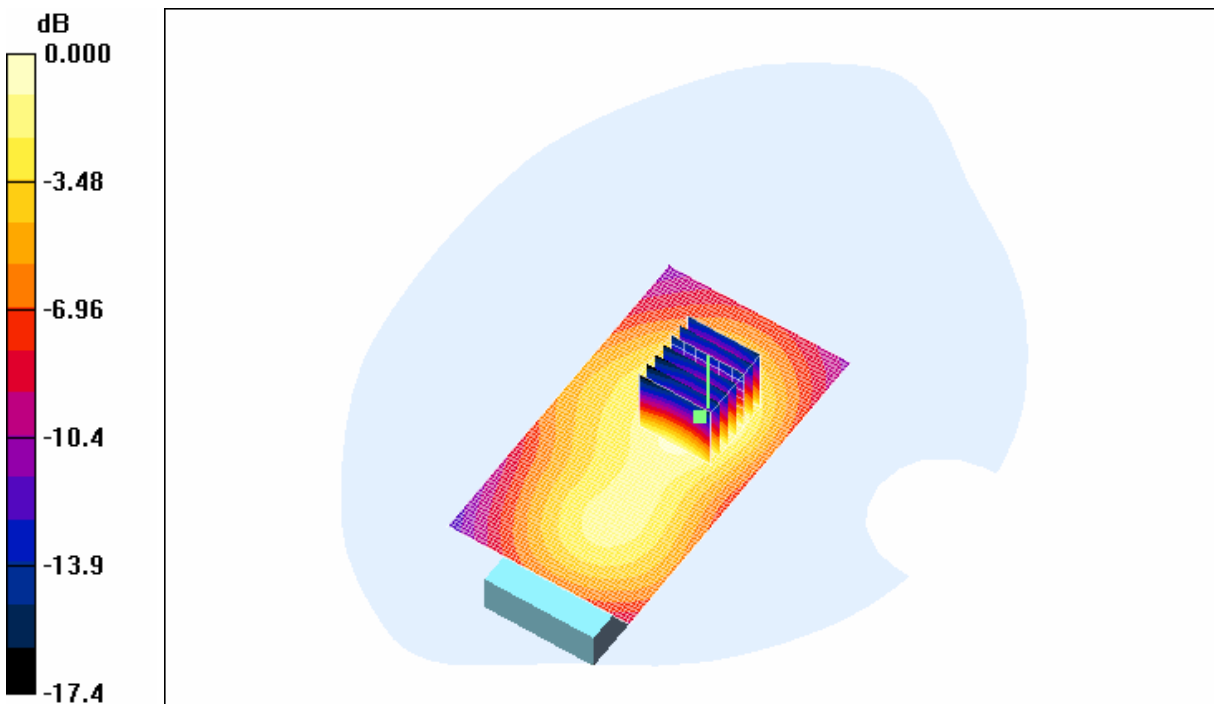

0 dB = 0.620mW/g

4.30Body-Worn-PCS1900-GPRS-High

Date/Time: 2006-5-30 16:09:25

Test Laboratory: SGS-GSM

FCC-OET65-Body-Worn-PCS1900-GPRS-High-2cm

DUT: GSM10000292E; Type: Body; Serial: 20060525

Communication System: PCS1900-GPRS Mode; Frequency: 1909.8 MHz; Duty Cycle: 1:4

Medium: HSL1900-Body Medium parameters used: $f = 1909.8$ MHz; $\sigma = 1.55$ mho/m; $\epsilon_r = 51.5$; $\rho = 1000$ kg/m³

Phantom section: Flat Section

Measurement Standard: DAS4 (High Precision Assessment)

DAS4 Configuration:

- Probe: ES3DV3 - SN3088; ConvF(4.53, 4.53, 4.53); Calibrated: 2005-9-13
- Sensor-Surface: 4mm (Mechanical Surface Detection)
- Electronics: DAE3 Sn569; Calibrated: 2005-11-17
- Phantom: SAM 12; Type: SAM V4.0; Serial: TP-1283
- Measurement SW: DAS4, V4.6 Build 23; Postprocessing SW: SEMCAD, V1.8 Build 160

Body Worn - High/Area Scan (51x91x1): Measurement grid: dx=15mm, dy=15mm

Maximum value of SAR (interpolated) = 0.486 mW/g

Body Worn - High/Zoom Scan (7x7x7) (7x7x7)/Cube 0: Measurement grid: dx=5mm, dy=5mm, dz=5mm

Reference Value = 16.6 V/m; Power Drift = -0.082 dB

Peak SAR (extrapolated) = 0.751 W/kg

SAR(1 g) = 0.441 mW/g; SAR(10 g) = 0.253 mW/g

Maximum value of SAR (measured) = 0.479 mW/g

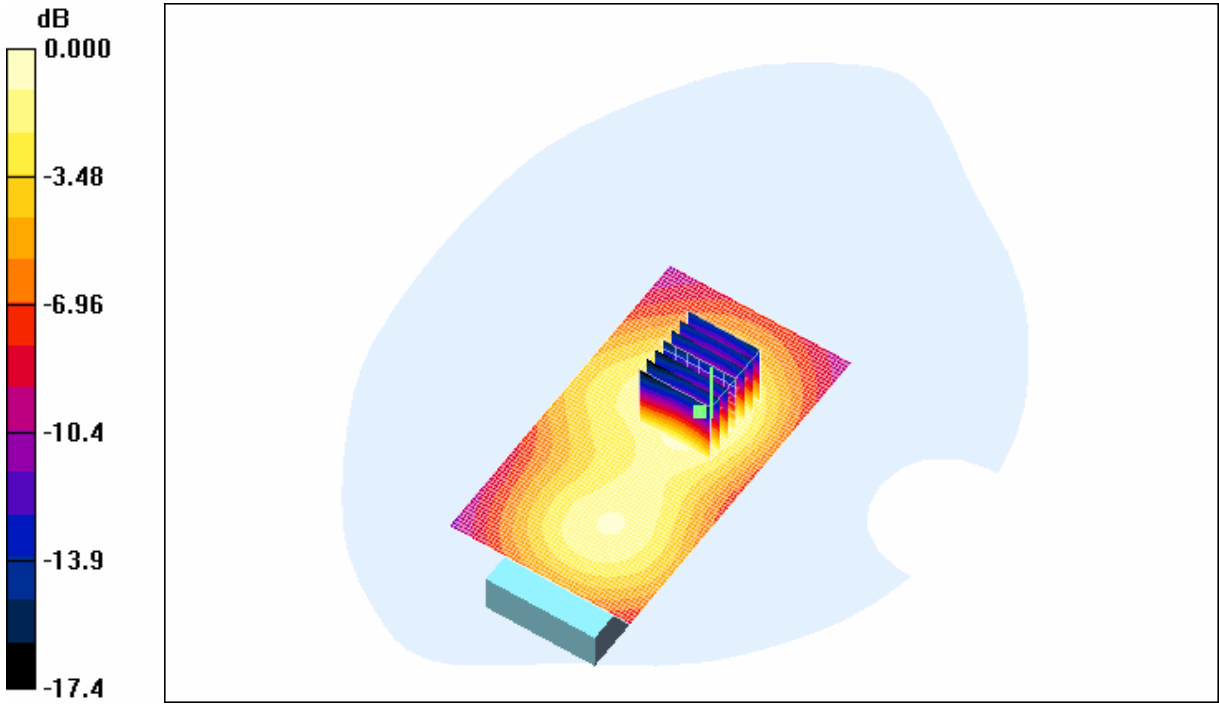

0 dB = 0.479mW/g

Appendix

1. Photographs of Test Setup

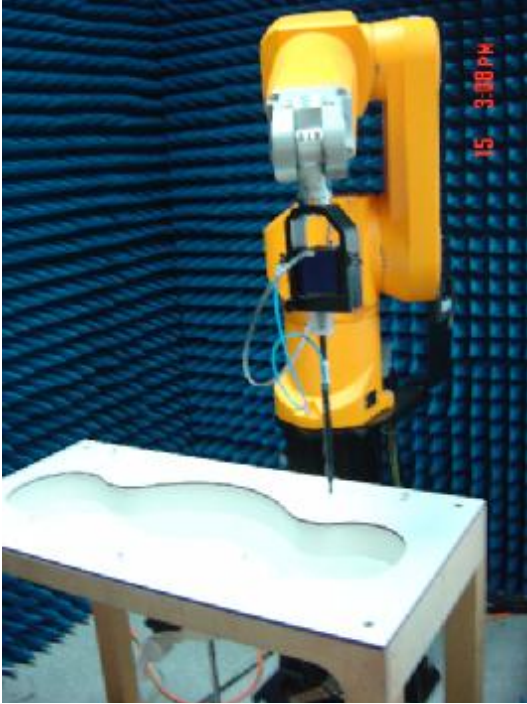

Fig.1 Photograph of the SAR measurement System

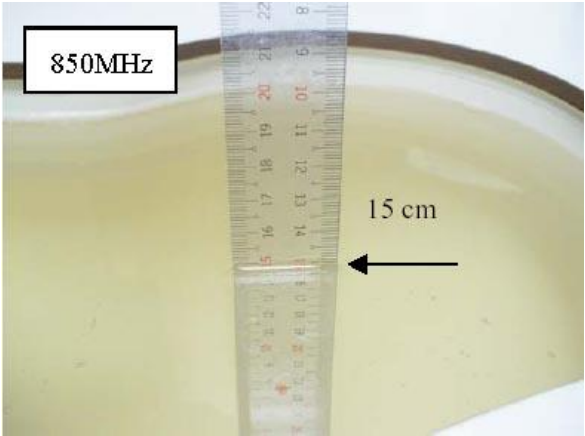

Fig.2 Photograph of the Tissue Simulant Fluid Liquid depth 15cm for Left-Head Side

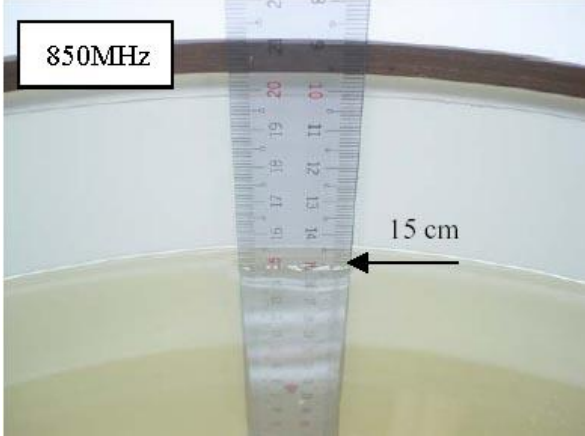

Fig.3 Photograph of the Tissue Simulant Liquid depth 15cm for Body-Worn

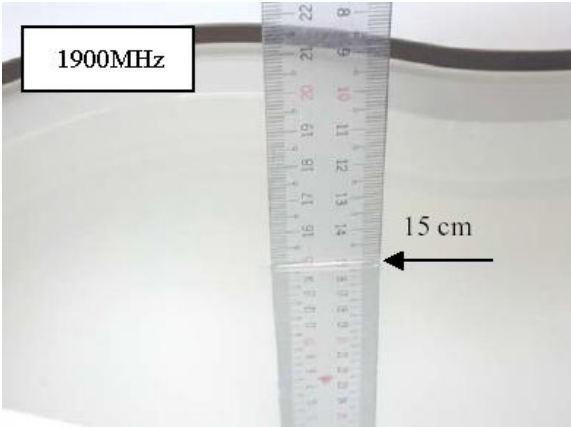

Fig.4 Photograph of the Tissue Simulant Fluid Liquid depth 15cm for Right-Head Side

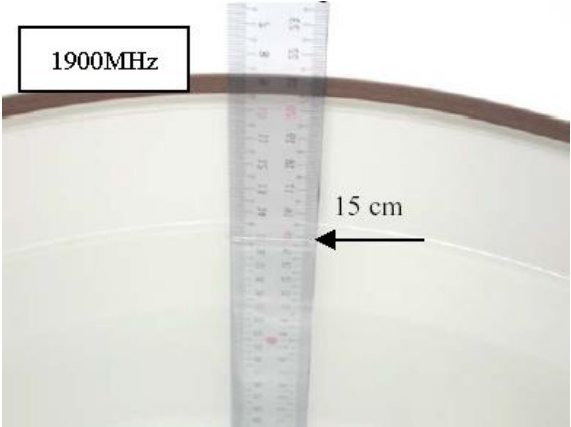

Fig.5 Photograph of the Tissue Simulant Liquid depth 15cm for Body-Worn

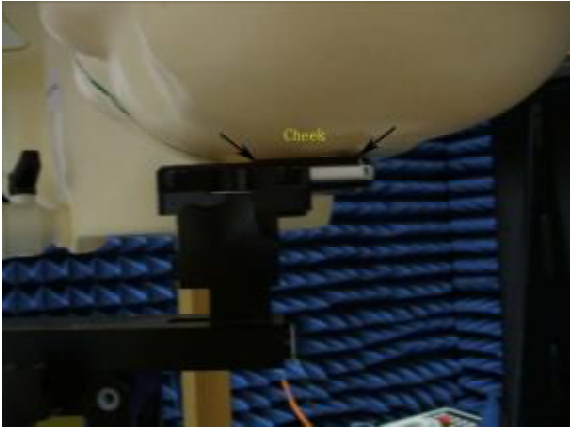

Fig.6 Photograph of the Left Hand Side Cheek status

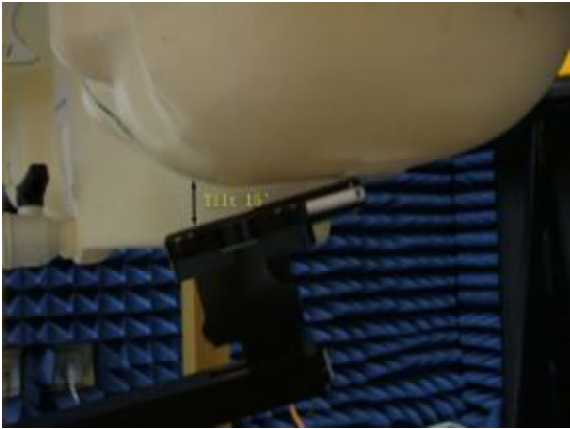

Fig.7 Photograph of the Left Hand Side Tilt status

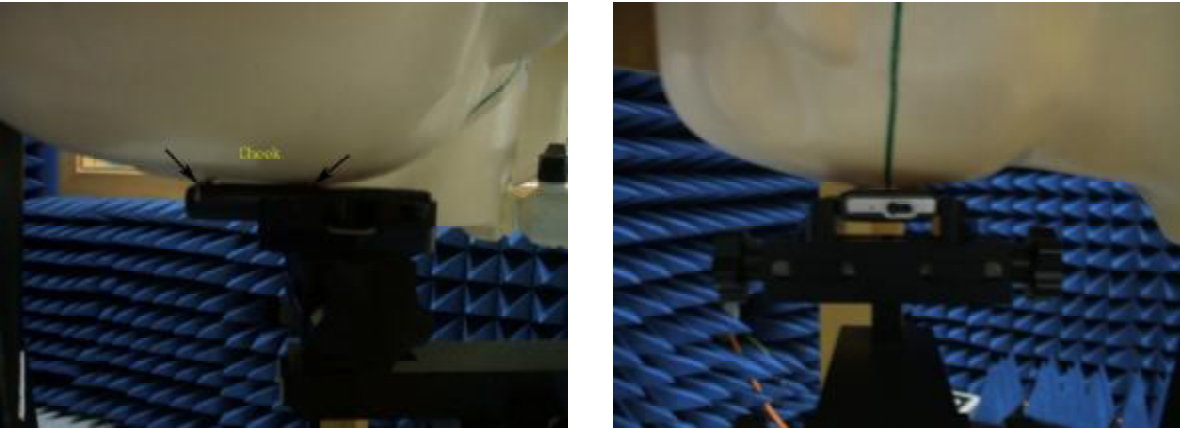

Fig.8 Photograph of the Right Hand Side Cheek status

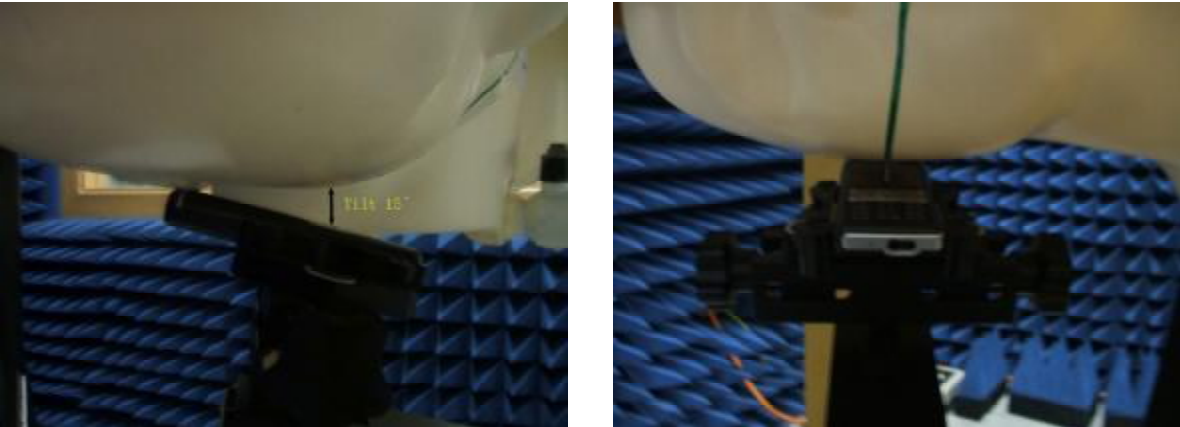

Fig.9 Photograph of the Right Hand Side Tilt status

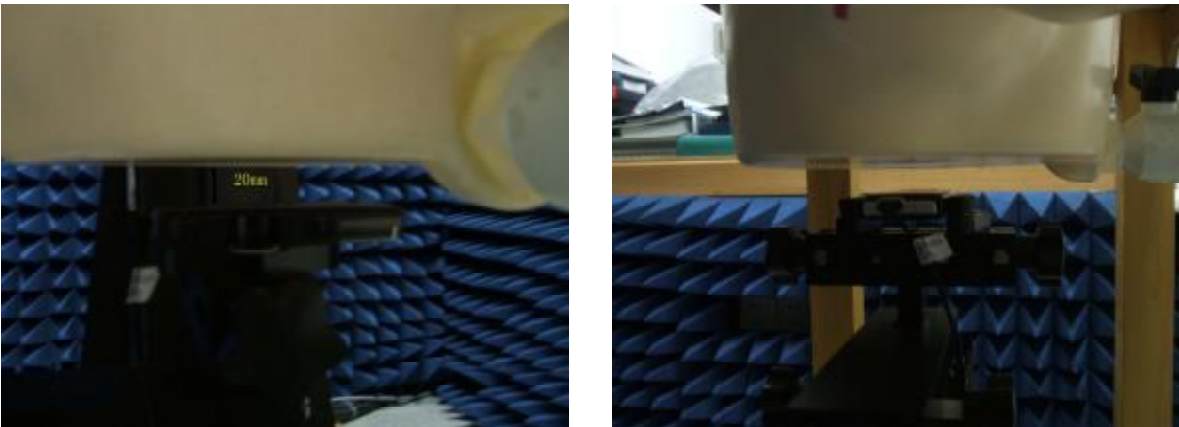

Fig.10 Photograph of the BodyWorn status

2. Photographs of the EUT



Fig.11 Front View



Fig.12 Back View

3. Photographs of the battery



Fig.13 Front view of battery



Fig.14 Back view of battery

4. Photograph of the charger



Fig.15 Charger

5. Probe Calibration certificate

**Calibration Laboratory of
Schmid & Partner
Engineering AG**
Zeughausstrasse 43, 8004 Zurich, Switzerland



S Schweizerischer Kalibrierdienst
S Service suisse d'étalonnage
C Servizio svizzero di taratura
S Swiss Calibration Service

Accredited by the Swiss Federal Office of Metrology and Accreditation
The Swiss Accreditation Service is one of the signatories to the EA
Multilateral Agreement for the recognition of calibration certificates

Accreditation No.: **SCS 108**Client: **SGS-CSTS (MTT)**Certificate No: **ES3-3088_Sep05****CALIBRATION CERTIFICATE**

Object: **ES3DV3 - SN.3088**

Calibration procedure(s): **QA CAL-01.v5
Calibration procedure for dosimetric E-field probes**

Calibration date: **September 13, 2005**

Condition of the calibrated item: **In Tolerance**

This calibration certificate documents the traceability to national standards, which realize the physical units of measurements (SI).
The measurements and the uncertainties with confidence probability are given on the following pages and are part of the certificate.

All calibrations have been conducted in the closed laboratory facility; environment temperature (22 ± 3)°C and humidity < 70%.

Calibration Equipment used (M&TE critical for calibration)

Primary Standards	ID #	Cal Date (Calibrated by, Certificate No.)	Scheduled Calibration
Power meter E4419B	GB41293874	3-May-05 (METAS, No. 251-00466)	May-06
Power sensor E4412A	MY41495277	3-May-05 (METAS, No. 251-00466)	May-06
Power sensor E4412A	MY41498987	3-May-05 (METAS, No. 251-00466)	May-06
Reference 3 dB Attenuator	SN: S5054 (3c)	11-Aug-05 (METAS, No. 251-00499)	Aug-06
Reference 20 dB Attenuator	SN: S5086 (20b)	3-May-05 (METAS, No. 251-00467)	May-06
Reference 30 dB Attenuator	SN: S5129 (30b)	11-Aug-05 (METAS, No. 251-00500)	Aug-06
Reference Probe ES3DV2	SN: 3013	7-Jan-05 (SPEAG, No. ES3-3013_Jan05)	Jan-06
DAE4	SN: 654	29-Nov-04 (SPEAG, No. DAE4-654_Nov04)	Nov-05

Secondary Standards	ID #	Check Date (in house)	Scheduled Check
RF generator HP 8648C	US3642U01700	4-Aug-06 (SPEAG, in house check Dec-03)	In house check: Dec-05
Network Analyzer HP 8753E	US37390585	18-Oct-01 (SPEAG, in house check Nov-04)	In house check: Nov-05

Calibrated by:	Name	Function	Signature
	Nico Vetterli	Laboratory Technician	
Approved by:	Katja Pokovic	Technical Manager	

Issued: September 15, 2005

This calibration certificate shall not be reproduced except in full without written approval of the laboratory.

Calibration Laboratory of
Schmid & Partner
Engineering AG
Zeughausstrasse 43, 8004 Zurich, Switzerland



S Schweizerischer Kalibrierdienst
C Service suisse d'étalonnage
S Servizio svizzero di taratura
S Swiss Calibration Service

Accredited by the Swiss Federal Office of Metrology and Accreditation
The Swiss Accreditation Service is one of the signatories to the EA
Multilateral Agreement for the recognition of calibration certificates

Accreditation No.: **SCS 108**

Glossary:

TSL	tissue simulating liquid
NORM _{x,y,z}	sensitivity in free space
ConF	sensitivity in TSL / NORM _{x,y,z}
DCP	diode compression point
Polarization φ	φ rotation around probe axis
Polarization ϑ	ϑ rotation around an axis that is in the plane normal to probe axis (at measurement center), i.e., $\vartheta = 0$ is normal to probe axis

Calibration is Performed According to the Following Standards:

- IEEE Std 1528-2003, "IEEE Recommended Practice for Determining the Peak Spatial-Averaged Specific Absorption Rate (SAR) in the Human Head from Wireless Communications Devices: Measurement Techniques", December 2003
- CENELEC EN 50361, "Basic standard for the measurement of Specific Absorption Rate related to human exposure to electromagnetic fields from mobile phones (300 MHz - 3 GHz), July 2001

Methods Applied and Interpretation of Parameters:

- NORM_{x,y,z}**: Assessed for E-field polarization $\vartheta = 0$ ($f \leq 900$ MHz in TEM-cell; $f > 1800$ MHz: R22 waveguide). NORM_{x,y,z} are only intermediate values, i.e., the uncertainties of NORM_{x,y,z} does not effect the E²-field uncertainty inside TSL (see below *ConvF*).
- NORM(*f*)_{x,y,z} = NORM_{x,y,z} * frequency_response** (see Frequency Response Chart). This linearization is implemented in DASY4 software versions later than 4.2. The uncertainty of the frequency response is included in the stated uncertainty of *ConvF*.
- DCP_{x,y,z}**: DCP are numerical linearization parameters assessed based on the data of power sweep (no uncertainty required). DCP does not depend on frequency nor media.
- ConvF and Boundary Effect Parameters**: Assessed in flat phantom using E-field (or Temperature Transfer Standard for $f \leq 800$ MHz) and inside waveguide using analytical field distributions based on power measurements for $f > 800$ MHz. The same setups are used for assessment of the parameters applied for boundary compensation (alpha, depth) of which typical uncertainty values are given. These parameters are used in DASY4 software to improve probe accuracy close to the boundary. The sensitivity in TSL corresponds to NORM_{x,y,z} * *ConvF* whereby the uncertainty corresponds to that given for *ConvF*. A frequency dependent *ConvF* is used in DASY version 4.4 and higher which allows extending the validity from ± 50 MHz to ± 100 MHz.
- Spherical isotropy (3D deviation from isotropy)**: in a field of low gradients realized using a flat phantom exposed by a patch antenna.
- Sensor Offset**: The sensor offset corresponds to the offset of virtual measurement center from the probe tip (on probe axis). No tolerance required.

ES3DV3 SN:3088

September 13, 2005

Probe ES3DV3

SN:3088

Manufactured: July 20, 2005
Calibrated: September 13, 2005

Calibrated for DASY Systems

(Note: non-compatible with DASY2 system!)

ES3DV3 SN:3088

September 13, 2005

DASY - Parameters of Probe: ES3DV3 SN:3088

Sensitivity in Free Space^A

Diode Compression^B

NormX	1.32 ± 10.1%	$\mu\text{V}/(\text{V}/\text{m})^2$	DCP X	95 mV
NormY	1.24 ± 10.1%	$\mu\text{V}/(\text{V}/\text{m})^2$	DCP Y	95 mV
NormZ	1.23 ± 10.1%	$\mu\text{V}/(\text{V}/\text{m})^2$	DCP Z	95 mV

Sensitivity in Tissue Simulating Liquid (Conversion Factors)

Please see Page 8.

Boundary Effect

TSL	900 MHz	Typical SAR gradient: 5 % per mm		
	Sensor Center to Phantom Surface Distance		3.0 mm	4.0 mm
	SAR _{iso} [%]	Without Correction Algorithm	5.8	2.7
	SAR _{iso} [%]	With Correction Algorithm	0.0	0.1
TSL	1750 MHz	Typical SAR gradient: 10 % per mm		
	Sensor Center to Phantom Surface Distance		3.0 mm	4.0 mm
	SAR _{iso} [%]	Without Correction Algorithm	7.6	4.5
	SAR _{iso} [%]	With Correction Algorithm	0.1	0.2

Sensor Offset

Probe Tip to Sensor Center 2.0 mm

The reported uncertainty of measurement is stated as the standard uncertainty of measurement multiplied by the coverage factor k=2, which for a normal distribution corresponds to a coverage probability of approximately 95%.

^A The uncertainties of NormX,Y,Z do not affect the E²-field uncertainty inside TSL (see Page 8).

^B Numerical linearization parameter: uncertainty not required.

ES3DV3 SN:3088

September 13, 2005

Frequency Response of E-Field (TEM-Cell:ifi110 EXX, Waveguide: R22)

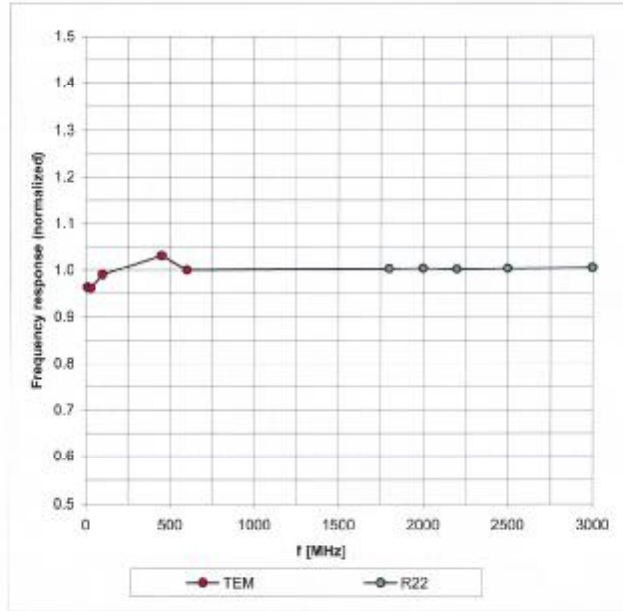

Uncertainty of Frequency Response of E-field: $\pm 6.3\%$ (k=2)

ES3DV3 SN:3088

September 13, 2005

Receiving Pattern (ϕ), $\theta = 0^\circ$

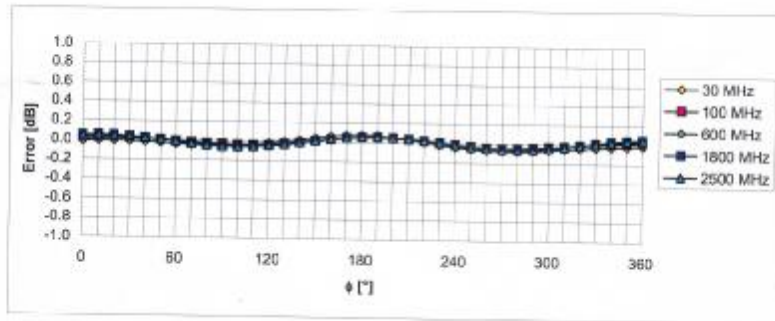
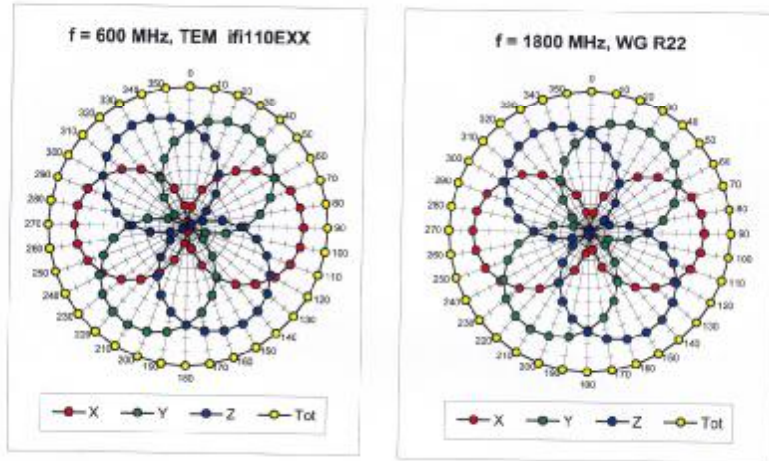

Uncertainty of Axial Isotropy Assessment: $\pm 0.5\%$ (k=2)

ES3DV3 SN:3088

September 13, 2005

Dynamic Range $f(SAR_{head})$ (Waveguide R22, $f = 1800$ MHz)

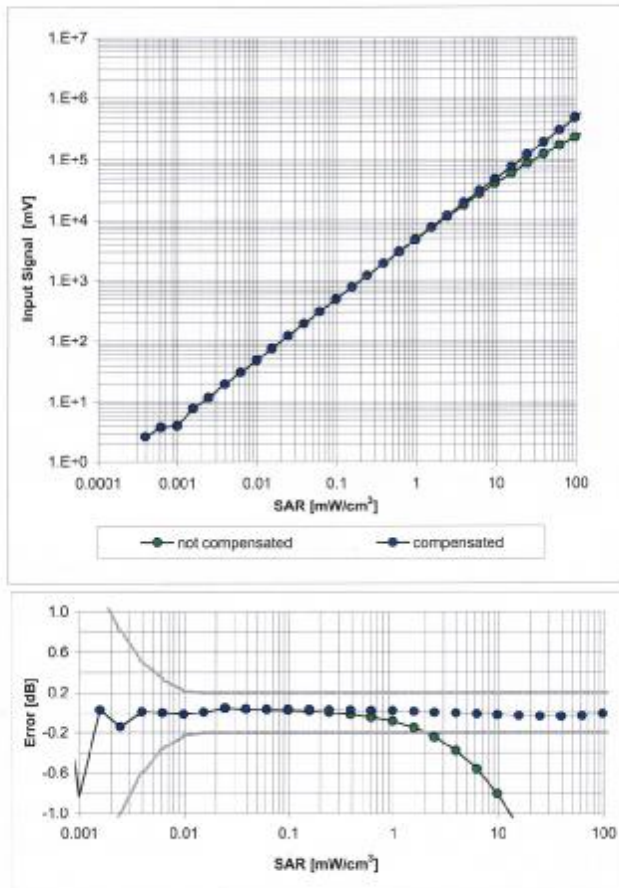

Uncertainty of Linearity Assessment: $\pm 0.6\%$ ($k=2$)

ES3DV3 SN:3088

September 13, 2005

Conversion Factor Assessment

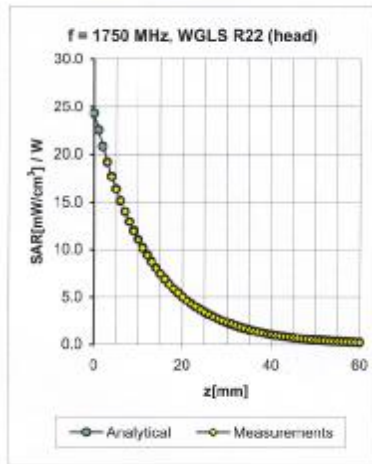
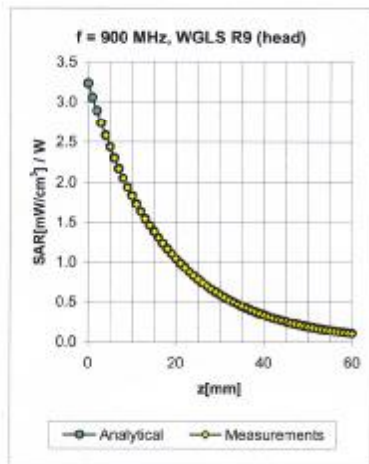

f [MHz]	Validity [MHz] ^c	TSL	Permittivity	Conductivity	Alpha	Depth	ConvF Uncertainty
900	± 50 / ± 100	Head	41.5 ± 5%	0.97 ± 5%	0.47	1.40	5.91 ± 11.0% (k=2)
1750	± 50 / ± 100	Head	40.1 ± 5%	1.37 ± 5%	0.24	2.39	4.97 ± 11.0% (k=2)
1900	± 50 / ± 100	Head	40.0 ± 5%	1.40 ± 5%	0.27	2.28	4.93 ± 11.0% (k=2)
2000	± 50 / ± 100	Head	40.0 ± 5%	1.40 ± 5%	0.25	2.34	4.87 ± 11.0% (k=2)
900	± 50 / ± 100	Body	55.0 ± 5%	1.05 ± 5%	0.61	1.25	5.83 ± 11.0% (k=2)
1750	± 50 / ± 100	Body	53.4 ± 5%	1.49 ± 5%	0.28	2.53	4.61 ± 11.0% (k=2)
1900	± 50 / ± 100	Body	53.3 ± 5%	1.52 ± 5%	0.28	2.57	4.53 ± 11.0% (k=2)
2000	± 50 / ± 100	Body	53.3 ± 5%	1.52 ± 5%	0.32	2.11	4.47 ± 11.0% (k=2)

^c The validity of ± 100 MHz only applies for DASY v4.4 and higher (see Page 2). The uncertainty is the RSS of the ConvF uncertainty at calibration frequency and the uncertainty for the indicated frequency band.

ES3DV3 SN:3088

September 13, 2005

Deviation from Isotropy in HSL

Error (ϕ , θ), $f = 900$ MHz

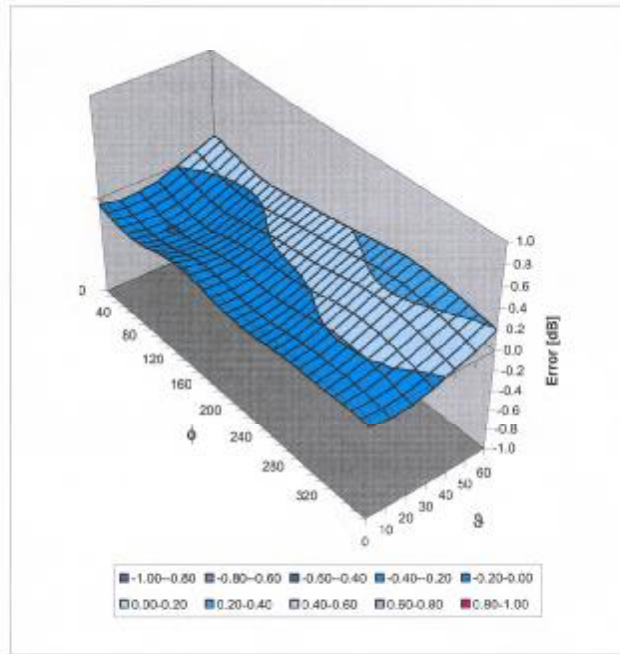

Uncertainty of Spherical Isotropy Assessment: $\pm 2.6\%$ ($k=2$)

6. Uncertainty analysis

Error Description	Tol. (± %)	Prob. dist.	Div.	(c_i) (1g)	(c_i) (10g)	Std. unc. (± %)		(v_i)
Measurement System								
Probe Calibration	4.8	N	1	1	1	4.8	4.8	∞
Axial Isotropy	4.7	R	$\sqrt{3}$	1	1	2.7	2.7	∞
Hemispherical Isotropy	0	R	$\sqrt{3}$	1	1	0	0	∞
Boundary Effects	1.0	R	$\sqrt{3}$	1	1	0.6	0.6	∞
Linearity	4.7	R	$\sqrt{3}$	1	1	2.7	2.7	∞
System Detection Limit	1.0	R	$\sqrt{3}$	1	1	0.6	0.6	∞
Readout Electronics	1.0	N	1	1	1	1.0	1.0	∞
Response Time	0	R	$\sqrt{3}$	1	1	0	0	∞
Integration Time	0	R	$\sqrt{3}$	1	1	0	0	∞
RF Ambient Conditions	3.0	R	$\sqrt{3}$	1	1	1.7	1.7	∞
Probe Positioner	0.4	R	$\sqrt{3}$	1	1	0.2	0.2	∞
Probe Positioning	2.9	R	$\sqrt{3}$	1	1	1.7	1.7	∞
Algorithms for Max. SAR Eval.	1.0	R	$\sqrt{3}$	1	1	0.6	0.6	∞
Dipole								
Dipole Axis to Liquid Distance	2.0	R	$\sqrt{3}$	1	1	1.2	1.2	∞
Input power and SAR drift meas.	4.7	R	$\sqrt{3}$	1	1	2.7	2.7	∞
Phantom and Tissue Param.								
Phantom Uncertainty	4.0	R	$\sqrt{3}$	1	1	2.3	2.3	∞
Liquid Conductivity (target)	5.0	R.	$\sqrt{3}$	0.64	0.43	1.8	1.2	∞
Liquid Conductivity (meas.)	2.5	N	1	0.64	0.43	1.6	1.1	∞
Liquid Permittivity (target)	5.0	R	$\sqrt{3}$	0.6	0.49	1.7	1.4	∞
Liquid Permittivity (meas.)	2.5	N	1	0.6	0.49	1.5	1.2	∞
Combined Standard Uncertainty						8.4	8.1	∞
Coverage Factor for 95%		$k_p=2$						
Expanded Uncertainty						16.8	16.2	

Dasy4 Uncertainty Budget

7. Phantom description

Schmid & Partner Engineering AG

Zughausstrasse 43, 8004 Zurich, Switzerland, Phone +41 1 245 97 00, Fax +41 1 245 97 79

Certificate of conformity / First Article Inspection

Item	SAM Twin Phantom V4.0
Type No	QD 000 P40 CA
Series No	TP-1150 and higher
Manufacturer / Origin	Unterseer Composites Hauptstr. 69 CH-8559 Fruttwilen Switzerland

Tests

The series production process used allows the limitation to test of first articles. Complete tests were made on the pre-series Type No. QD 000 P40 AA, Serial No. TP-1001 and on the series first article Type No. QD 000 P40 BA, Serial No. TP-1006. Certain parameters have been retested using further series units (called samples).

Test	Requirement	Details	Units tested
Shape	Compliance with the geometry according to the CAD model.	ITIS CAD File (*)	First article, Samples
Material thickness	Compliant with the requirements according to the standards	2mm +/- 0.2mm in specific areas	First article, Samples
Material parameters	Dielectric parameters for required frequencies	200 MHz - 3 GHz Relative permittivity < 6 Loss tangent < 0.05.	Material sample TP 104-5
Material resistivity	The material has been tested to be compatible with the liquids defined in the standards	Liquid type HSL 1800 and others according to the standard.	Pre-series, First article

Standards

- [1] CENELEC EN 50361
- [2] IEEE P1528-200x draft 6.5
- [3] IEC PT 62209 draft 0.9
- (*) The ITIS CAD file is derived from [2] and is also within the tolerance requirements of the shapes of [1] and [3].

Conformity

Based on the sample tests above, we certify that this item is in compliance with the uncertainty requirements of SAR measurements specified in standard [1] and draft standards [2] and [3].

Date

28.02.2002

Signature / Stamp

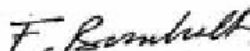

Schmid & Partner
Engineering AG

Zughausstrasse 43, CH-8004 Zurich
Tel. +41 1 245 97 00, Fax +41 1 245 97 79

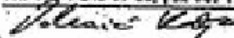

8. System validation from original equipment supplier

DASY4 Validation Report for Head TSL

Date/Time: 19.08.2005 14:48:37

Test Laboratory: SPEAG, Zurich, Switzerland

DUT: Dipole 900 MHz; Type: D900V2; Serial: D900V2 - SN:184

Communication System: CW-900; Frequency: 900 MHz; Duty Cycle: 1:1

Medium: HSL 900 MHz;

Medium parameters used: $f = 900$ MHz; $\sigma = 0.96$ mho/m; $\epsilon_r = 42.1$; $\rho = 1000$ kg/m³

Phantom section: Flat Section

Measurement Standard: DASY4 (High Precision Assessment)

DASY4 Configuration:

- Probe: ET3DV6 - SN1507; ConvF(5.95, 5.95, 5.95); Calibrated: 26.10.2004
- Sensor-Surface: 4mm (Mechanical Surface Detection)
- Electronics: DAE4 Sn601; Calibrated: 07.01.2005
- Phantom: Flat Phantom 4.9L; Type: QD000P49AA
- Measurement SW: DASY4, V4.6 Build 9; Postprocessing SW: SEMCAD, V1.8 Build 151

Pin = 250 mW; d = 15 mm/Area Scan (81x81x1):

Measurement grid: dx=15mm, dy=15mm

Maximum value of SAR (interpolated) = 2.81 mW/g

Pin = 250 mW; d = 15 mm/Zoom Scan 2 (7x7x7)/Cube 0:

Measurement grid: dx=5mm, dy=5mm, dz=5mm

Reference Value = 56.9 V/m; Power Drift = -0.018 dB

Peak SAR (extrapolated) = 3.84 W/kg

SAR(1 g) = 2.6 mW/g; SAR(10 g) = 1.67 mW/g

Maximum value of SAR (measured) = 2.82 mW/g

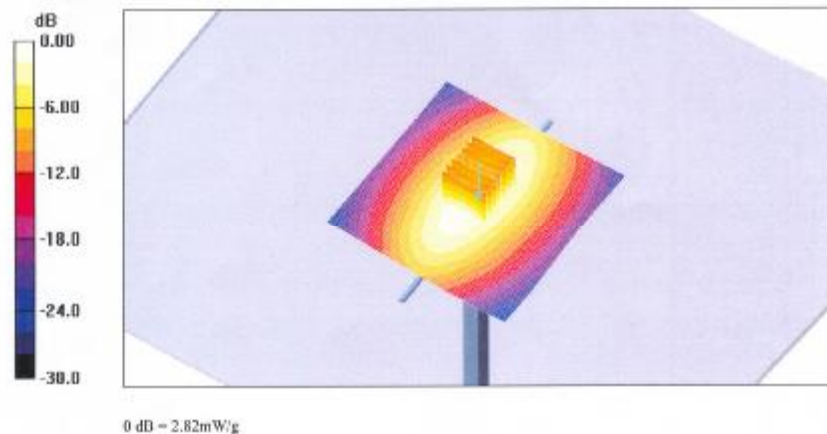

DASY4 Validation Report for Body TSL

Date/Time: 22.08.2005 16:14:01

Test Laboratory: SPEAG, Zurich, Switzerland

DUT: Dipole 900 MHz; Type: D900V2; Serial: D900V2 - SN:184

Communication System: CW-900; Frequency: 900 MHz; Duty Cycle: 1:1

Medium: MSL 900 MHz;

Medium parameters used: $f = 900$ MHz; $\sigma = 1.07$ mho/m; $\epsilon_r = 54.6$; $\rho = 1000$ kg/m³

Phantom section: Flat Section

Measurement Standard: DASY4 (High Precision Assessment)

DASY4 Configuration:

- Probe: ET3DV6 - SN1507; ConvF(5.77, 5.77, 5.77); Calibrated: 26.10.2004
- Sensor-Surface: 4mm (Mechanical Surface Detection)
- Electronics: DAE4 Sn601; Calibrated: 07.01.2005
- Phantom: Flat Phantom 4.9L; Type: QD000P49AA
- Measurement SW: DASY4, V4.6 Build 9; Postprocessing SW: SEMCAD, V1.8 Build 151

Pin = 250 mW; d = 15 mm 2/Area Scan (81x81x1):

Measurement grid: dx=15mm, dy=15mm

Maximum value of SAR (interpolated) = 2.94 mW/g

Pin = 250 mW; d = 15 mm 2/Zoom Scan (7x7x7)/Cube 0:

Measurement grid: dx=5mm, dy=5mm, dz=5mm

Reference Value = 55.3 V/m; Power Drift = -0.00 dB

Peak SAR (extrapolated) = 3.90 W/kg

SAR(1 g) = 2.69 mW/g; SAR(10 g) = 1.74 mW/g

Maximum value of SAR (measured) = 2.96 mW/g

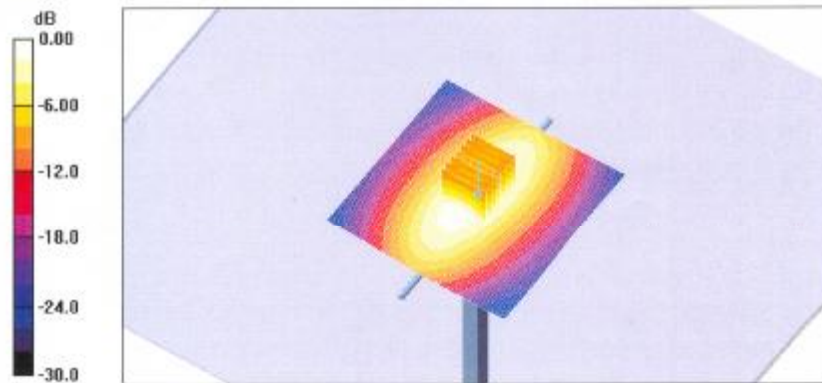

0 dB = 2.96mW/g

DASY4 Validation Report for Head TSL

Date/Time: 25.08.2005 17:04:02

Test Laboratory: SPEAG, Zurich, Switzerland

DUT: Dipole 1900 MHz; Type: D1900V2; Serial: D1900V2 - SN:5d028

Communication System: CW-1900; Frequency: 1900 MHz; Duty Cycle: 1:1

Medium: HSL 1900 MHz;

Medium parameters used: $f = 1900$ MHz; $\sigma = 1.47$ mho/m; $\epsilon_r = 38.6$; $\rho = 1000$ kg/m³

Phantom section: Flat Section

Measurement Standard: DASY4 (High Precision Assessment)

DASY4 Configuration:

- Probe: ET3DV6 - SN1507; ConvF(4.96, 4.96, 4.96); Calibrated: 26.10.2004
- Sensor-Surface: 4mm (Mechanical Surface Detection)
- Electronics: DAE4 Sn601; Calibrated: 07.01.2005
- Phantom: Flat Phantom 5.0 (front); Type: QD000P50AA
- Measurement SW: DASY4, V4.6 Build 9; Postprocessing SW: SEMCAD, V1.8 Build 151

Pin = 250 mW; d = 10 mm/Area Scan (61x81x1):

Measurement grid: dx=15mm, dy=15mm

Maximum value of SAR (interpolated) = 11.8 mW/g

Pin = 250 mW; d = 10 mm/Zoom Scan (7x7x7)/Cube 0:

Measurement grid: dx=5mm, dy=5mm, dz=5mm

Reference Value = 91.5 V/m; Power Drift = 0.00 dB

Peak SAR (extrapolated) = 17.2 W/kg

SAR(1 g) = 9.89 mW/g; SAR(10 g) = 5.16 mW/g

Maximum value of SAR (measured) = 11.2 mW/g

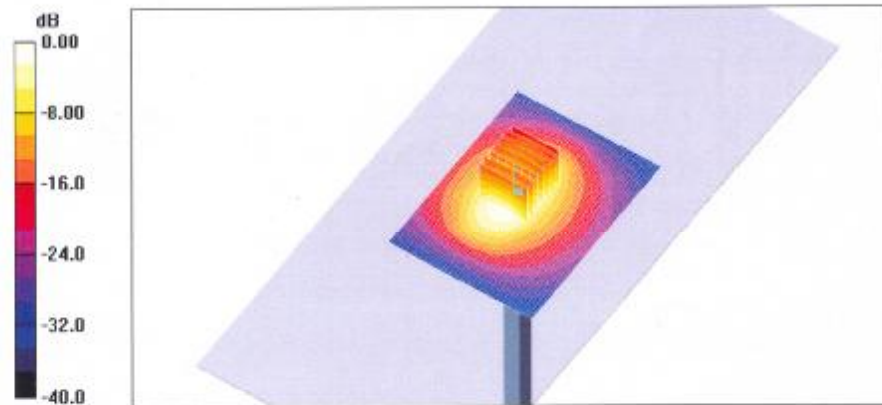

0 dB = 11.2mW/g

DASY4 Validation Report for Body TSL

Date/Time: 26.08.2005 15:32:29

Test Laboratory: SPEAG, Zurich, Switzerland

DUT: Dipole 1900 MHz; Type: D1900V2; Serial: D1900V2 - SN:5d028

Communication System: CW-1900; Frequency: 1900 MHz; Duty Cycle: 1:1

Medium: MSL 1900 MHz;

Medium parameters used: $f = 1900$ MHz; $\sigma = 1.6$ mho/m; $\epsilon_r = 53.3$; $\rho = 1000$ kg/m³.

Phantom section: Flat Section

Measurement Standard: DASY4 (High Precision Assessment)

DASY4 Configuration:

- Probe: ET3DV6 - SN1507; ConvF(4.43, 4.43, 4.43); Calibrated: 26.10.2004
- Sensor-Surface: 4mm (Mechanical Surface Detection)
- Electronics: DAE4 Sn601; Calibrated: 07.01.2005
- Phantom: Flat Phantom 5.0 (front); Type: QD000P50AA
- Measurement SW: DASY4, V4.6 Build 9; Postprocessing SW: SEMCAD, V1.8 Build 151

Pin = 250 mW; d = 10 mm 2/Area Scan (81x81x1):

Measurement grid: dx=15mm, dy=15mm

Maximum value of SAR (interpolated) = 11.2 mW/g

Pin = 250 mW; d = 10 mm 2/Zoom Scan (7x7x7)/Cube 0:

Measurement grid: dx=5mm, dy=5mm, dz=5mm

Reference Value = 86.7 V/m; Power Drift = -0.025 dB

Peak SAR (extrapolated) = 16.4 W/kg

SAR(1 g) = 9.81 mW/g; SAR(10 g) = 5.22 mW/g

Maximum value of SAR (measured) = 11.2 mW/g

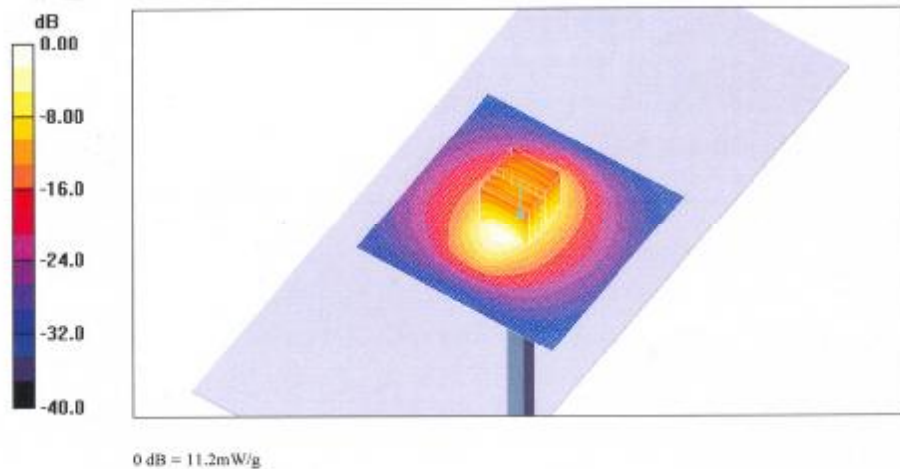

The end