

# SAR TEST REPORT

<b>Equipment Under Test :</b>	GSM 850&PCS1900MHz MOBILE PHONE
<b>FCC ID :</b>	RAD024
<b>Model No. :</b>	VLE5
<b>Market Name :</b>	OT-E257a
<b>Applicant :</b>	TCL&Alcatel Mobile Phones
<b>Address of Applicant :</b>	30/F, Times Square, 500 Zhangyang RD. Shanghai 200122, P.R.China
<b>Date of Receipt :</b>	2005.09.13
<b>Date of Test :</b>	2005.09.15 – 2005.09.21
<b>Date of Issue :</b>	2005.10.19

Standards:

## FCC OET Bulletin 65 supplement C, ANSI/IEEE C95.1, C95.3, IEEE 1528-2002

In the configuration tested, the EUT complied with the standards specified above.

### Remarks:

This report details the results of the testing carried out on one sample, the results contained in this test report do not relate to other samples of the same product. The manufacturer should ensure that all products in series production are in conformity with the product sample detailed in this report.

This report may only be reproduced and distributed in full. If the product in this report is used in any configuration other than that detailed in the report, the manufacturer must ensure the new system complies with all relevant standards. Any mention of SGS-CSTC Shanghai GSM Lab or testing done by SGS-CSTC Shanghai GSM Lab must approve SGS Shanghai GSM Lab in connection with distribution or use of the product described in this report in writing.

Tested by :

*Alpha Xie*

Date :

2005.10.19

Approved by :

*Zhang Yuan*

Date :

2005.10.19

# Contents

<b>1. General Information .....</b>	<b>5</b>
1.1 Test Laboratory.....	5
1.2 Details of Applicant .....	5
1.3 Description of EUT(s).....	5
1.4 Test Environment .....	6
1.5 Operation Configuration .....	6
1.6 The SAR Measurement System.....	6
1.7 SAR System Verification.....	8
1.8 Tissue Simulant Fluid for the Frequency Band 850MHz and 1900MHZ .....	9
1.9 Test Standards and Limits .....	10
<b>2. Summary of Results .....</b>	<b>11</b>
<b>3. Instruments List .....</b>	<b>13</b>
<b>4. Measurements .....</b>	<b>14</b>
<b>4.1 FCC-OET65-LeftHandSide-Touch-GSM850-Low .....</b>	<b>14</b>
FCC-OET65-LeftHandSide-Touch-GSM850-Low .....	14
<b>4.2 FCC-OET65-LeftHandSide-Touch-GSM850-Mid .....</b>	<b>15</b>
FCC-OET65-LeftHandSide-Touch-GSM850-Mid .....	16
<b>4.3 FCC-OET65-LeftHandSide-Touch-GSM850-High .....</b>	<b>17</b>
FCC-OET65-LeftHandSide-Touch-GSM850-High.....	17
<b>4.4 FCC-OET65-LeftHandSide-Tilt-GSM850-Low .....</b>	<b>19</b>
FCC-OET65-LeftHandSide-Tilt-GSM850-Low .....	19
<b>4.5 FCC-OET65-LeftHandSide-Tilt-GSM850-Mid .....</b>	<b>21</b>
FCC-OET65-LeftHandSide-Tilt-GSM850-Mid .....	21
<b>4.6 FCC-OET65-LeftHandSide-Tilt-GSM850-High.....</b>	<b>23</b>
FCC-OET65-LeftHandSide-Tilt-GSM850-High.....	23
<b>4.7 FCC-OET65-RightHandSide-Touch-GSM850-Low .....</b>	<b>25</b>
FCC-OET65-RightHandSide-Touch-GSM850-Low .....	25
<b>4.8 FCC-OET65-RightHandSide-Touch-GSM850-Mid .....</b>	<b>27</b>
FCC-OET65-RightHandSide-Touch-GSM850-Mid.....	27
<b>4.9 FCC-OET65-RightHandSide-Touch-GSM850-High.....</b>	<b>29</b>
FCC-OET65-RightHandSide-Touch-GSM850-High .....	29
<b>4.10 FCC-OET65-RightHandSide-Tilt-GSM850-Low.....</b>	<b>31</b>

FCC-OET65-RightHandSide-Tilt-GSM850-Low .....	31
<b>4.11 FCC-OET65-RightHandSide-Tilt-GSM850-Mid.....</b>	<b>33</b>
FCC-OET65-RightHandSide-Tilt-GSM850-Mid.....	33
<b>4.12 FCC-OET65-RightHandSide-Tilt-GSM850-High.....</b>	<b>35</b>
FCC-OET65-RightHandSide-Tilt-GSM850-High .....	35
<b>4.13 FCC-OET65-Body-Worn-GSM850-Low.....</b>	<b>37</b>
FCC-OET65-Body-Worn-GSM850-Low.....	37
<b>4.14 FCC-OET65-Body-Worn-GSM850-Mid.....</b>	<b>39</b>
FCC-OET65-Body-Worn-GSM850-Mid.....	39
<b>4.15 FCC-OET65-Body-Worn-GSM850-High.....</b>	<b>41</b>
FCC-OET65-Body-Worn-GSM850-High .....	41
<b>4.16 FCC-OET65-LeftHandSide-Touch-GSM1900-Low .....</b>	<b>43</b>
FCC-OET65-LeftHandSide-Touch-GSM1900-Low .....	43
<b>4.17 FCC-OET65-LeftHandSide-Touch-GSM1900-Mid .....</b>	<b>45</b>
FCC-OET65-LeftHandSide-Touch-GSM1900-Mid .....	45
<b>4.18 FCC-OET65-LeftHandSide-Touch-GSM1900-High .....</b>	<b>47</b>
FCC-OET65-LeftHandSide-Touch-GSM1900-High.....	47
<b>4.19 FCC-OET65-LeftHandSide-Tilt-GSM1900-Low .....</b>	<b>49</b>
FCC-OET65-LeftHandSide-Tilt-GSM1900-Low .....	49
<b>4.20 FCC-OET65-LeftHandSide-Tilt-GSM1900-Mid .....</b>	<b>51</b>
FCC-OET65-LeftHandSide-Tilt-GSM1900-Mid .....	51
<b>4.21 FCC-OET65-LeftHandSide-Tilt-GSM1900-High.....</b>	<b>53</b>
FCC-OET65-LeftHandSide-Tilt-GSM1900-High.....	53
<b>4.22 FCC-OET65-RightHandSide-Touch-GSM1900-Low.....</b>	<b>55</b>
FCC-OET65-RightHandSide-Touch-GSM1900-Low .....	55
<b>4.23 FCC-OET65-RightHandSide-Touch-GSM1900-Mid .....</b>	<b>57</b>
FCC-OET65-RightHandSide-Touch-GSM1900-Mid.....	57
<b>4.24 FCC-OET65-RightHandSide-Touch-GSM1900-High.....</b>	<b>59</b>
FCC-OET65-RightHandSide-Touch-GSM1900-High .....	59
<b>4.25 FCC-OET65-RightHandSide-Tilt-GSM1900-Low.....</b>	<b>61</b>
FCC-OET65-RightHandSide-Tilt-GSM1900-Low .....	61
<b>4.26 FCC-OET65-RightHandSide-Tilt-GSM1900-Mid.....</b>	<b>63</b>
FCC-OET65-RightHandSide-Tilt-GSM1900-Mid.....	63
<b>4.27 FCC-OET65-RightHandSide-Tilt-GSM1900-High.....</b>	<b>65</b>

FCC-OET65-RightHandSide-Tilt-GSM1900-High .....	65
<b>4.28 FCC-OET65-Body-Worn-GSM1900-Low.....</b>	<b>67</b>
FCC-OET65-Body-Worn-GSM1900-Low .....	67
<b>4.29 FCC-OET65-Body-Worn-GSM1900-Mid.....</b>	<b>69</b>
FCC-OET65-Body-Worn-GSM1900-Mid.....	69
<b>4.30 FCC-OET65-Body-Worn-GSM1900-High.....</b>	<b>71</b>
FCC-OET65-Body-Worn-GSM1900-High .....	71
<b>Appendix .....</b>	<b>74</b>
1. Photographs of Test Setup.....	74
2. Photographs of the EUT .....	77
3. Photographs of the battery.....	77
4. Photograph of the charger .....	78
5. Probe Calibration certificate.....	79
6. Uncertainty analysis .....	87
7. Phantom description .....	88

## 1. General Information

### 1.1 Test Laboratory

GSM Lab  
 SGS-CSTC Standards Technical Services Co.Ltd Shanghai Branch  
 9F,the 3<sup>rd</sup> Building, No.899, Yishan Rd, Xuhui District, Shanghai, China  
 Zip code: 200233  
 Telephone: +86 (0) 21 6495 1616  
 Fax: +86 (0) 21 6495 3679  
 Internet: <http://www.cn.sgs.com>

### 1.2 Details of Applicant

Name: TCL&Alcatel Mobile Phones  
 Address: 30/F, Times Square, 500 Zhangyang RD. Shanghai  
 200122, P.R.China

### 1.3 Description of EUT(s)

Brand name	Alcatel	
Model No.	VLE5	
Market Name	OT-E257a	
Serial No.	IMEI: 001016000320213	
Battery Type	Lithium-Ion, 3.7Volt	
Antenna Type	External Antenna	
Operation Mode	GSM850/PCS1900	
Modulation Mode	GMSK	
Frequency range	GSM850	Tx: 824~849 MHz
		Rx: 869~894 MHz
	GSM1900	Tx: 1850~1910 MHz
		Rx: 1930~1990 MHz
Maximum RF Conducted Power	GSM850: 33dBm, GSM1900: 30dBm	

#### **1.4 Test Environment**

Ambient temperature: 22.0° C

Tissue Simulating Liquid: 22° C

Relative Humidity: 32%

#### **1.5 Operation Configuration**

Configuration 1: GSM 850, LeftHandSide Touch & 15°Tilt Position

Configuration 2: GSM 850, RightHandSide Touch & 15°Tilt Position

Configuration 3: GSM 850, BodyWorn (1.5cm between EUT and phantom)

Configuration 4: GSM 1900, LeftHandSide Touch & 15°Tilt Position

Configuration 5: GSM 1900, RightHandSide Touch & 15°Tilt Position

Configuration 6: GSM 1900, BodyWorn (1.5cm between EUT and phantom)

#### **1.6 The SAR Measurement System**

A photograph of the SAR measurement System is given in Fig.a.

This SAR Measurement System uses a Computer-controlled 3-D stepper motor system (Speag Dasy 4 professional system). A Model ET3DV6 1774 E-field probe is used to determine the internal electric fields. The SAR can be obtained from the equation  $SAR = \sigma (|E_i|^2) / \rho$  where  $\sigma$  and  $\rho$  are the conductivity and mass density of the tissue-simulant.

The DASY4 system for performing compliance tests consists of the following items:

- ÿ A standard high precision 6-axis robot (Stabile RX family) with controller, teach pendant and software. An arm extension for accommodation the data acquisition electronics (DAE).
- ÿ A dosimetric probe, i.e., an isotropic E-field probe optimized and calibrated for usage in tissue simulating liquid. The probe is equipped with an optical surface detector system.
- ÿ A data acquisition electronics (DAE) which performs the signal amplification, signal

multiplexing, AD-conversion, offset measurements, mechanical surface detection, collision detection, etc. The unit is battery powered with standard or rechargeable batteries. The signal is optically transmitted to the EOC.

- The Electro-optical converter (EOC) performs the conversion between optical and electrical of the signals for the digital communication to DAE and for the analog signal from the optical surface detection. The EOC is connected to the measurement server.

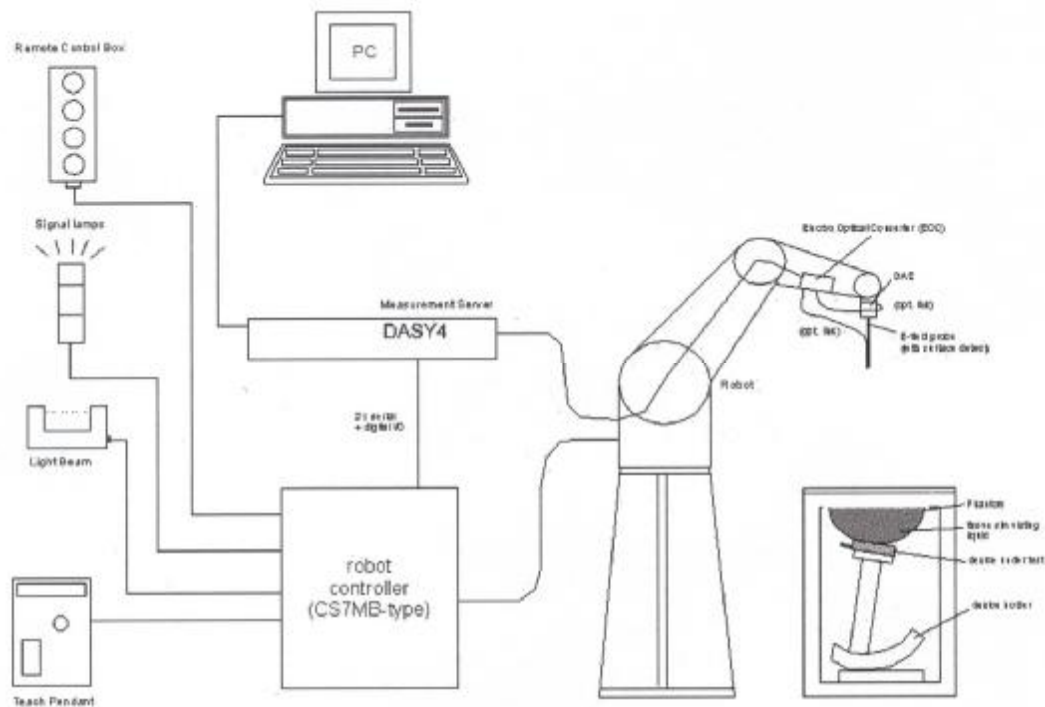

Fig. a SAR System Configuration

- The function of the measurement server is to perform the time critical tasks such as signal filtering, control of the robot operation and fast movement interrupts.
- A probe alignment unit which improves the (absolute) accuracy of the probe positioning.
- A computer operating Windows 2000 or Windows XP.
- DASY4 software.
- Remote control with teach pendant and additional circuitry for robot safety such as warning lamps, etc.

- ÿ The SAM twin phantom enabling testing left-hand, right-hand and body-worn usage.
- ÿ The device holder for handheld mobile phones.
- ÿ Tissue simulating liquid mixed according to the given recipes.
- ÿ Validation dipole kits allowing to validate the proper functioning of the system.

### 1.7 SAR System Verification

The microwave circuit arrangement for system verification is sketched in Fig. b. The daily system accuracy verification occurs within the flat section of the SAM phantom. A SAR measurement was performed to see if the measured SAR was within +/- 10% from the target SAR values. These tests were done at 850MHz and 1900MHz. The tests were conducted on the same days as the measurement of the DUT. The obtained results from the system accuracy verification are displayed in the table 1 (SAR values are normalized to 1W forward power delivered to the dipole). During the tests, the ambient temperature of the laboratory was in the range 22°C, the relative humidity was in the range 60% and the liquid depth above the ear reference points was above 15 cm in all the cases. It is seen that the system is operating within its specification, as the results are within acceptable tolerance of the reference values.

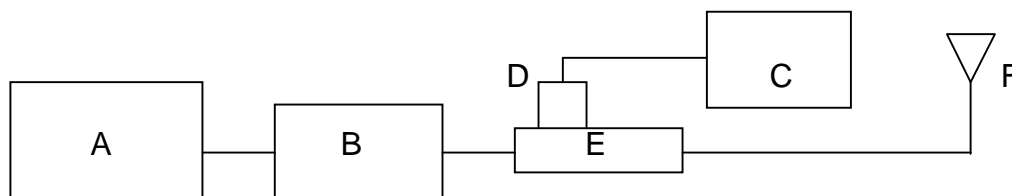

Fig. b the microwave circuit arrangement used for SAR system verification

- A. Agilent Model E4438C Signal Generator
- B. Agilent Model 8449B Preamplifier
- C. Agilent Model E4416A Power Meter
- D. Agilent Model 8481H Power Sensor
- E. HT CP6100 20N Dual directional coupler
- F. Reference dipole antenna



Validation Kit	Frequency (MHZ)	Target SAR 1g (250mW)	Target SAR 10g (250mW)	Measured SAR 1g	Measured SAR 10g	Measured Date
ET3DV6 SN1774	900 Head	2.69	1.73	2.57	1.66	2005-09-14
ET3DV6 SN1774	900M Body	2.75	1.77	2.69	1.71	2005-09-21
ET3DV6 SN1774	1900M Head	10.4	5.35	10.29	5.28	2005-09-20
ET3DV6 SN1774	1900M Body	10.52	5.53	10.37	5.36	2005-09-21

Table 1. Result System Validation

### 1.8 Tissue Simulant Fluid for the Frequency Band 850MHz and 1900MHz

The dielectric properties for this body-simulant fluid were measured by using the HP Model 85070D Dielectric Probe (rates frequency band 200 MHz to 20 GHz) in conjunction with Agilent E5071B Network Analyzer (300 KHz-8500 MHz). The Conductivity ( $\sigma$ ) and Permittivity ( $\rho$ ) are listed in Table 2. For the SAR measurement given in this report. The temperature variation of the Tissue Simulant Fluid was 22 °C.

Frequency (MHz)	Tissue Type	Limit/Measured	Permittivity ( $\rho$ )	Conductivity ( $\sigma$ )	Simulated Tissue Temp (°C)
850	Head	Measured, 2005-09-14	41.69	0.877	21.8
		Recommended Limit	41.5±5%	0.90±10%	20-24
	Body	Measured, 2005-09-21	52.52	0.997	22.0
		Recommended Limit	55.2±5%	0.97±10%	20-24
1900	Head	Measured, 2005-09-20	39.99	1.46	22.5
		Recommended Limit	40.0±5%	1.40±10%	20-24
	Body	Measured, 2005-09-21	51.46	1.55	22.2
		Recommended Limit	53.3±5%	1.52±10%	20-24

Table 2. Dielectric parameters for the Frequency Band 850MHz&1900MHz

### 1.9 Test Standards and Limits

According to FCC 47 CFR §2.1093(d) the limits to be used for evaluation are based generally on criteria published by the American National Standards Institute (ANSI) for localized specific absorption rate (SAR) in Section 4.2 of "IEEE Standard for Safty Levels with Respect to Human Exposure to Radio Frequency Electromagnetic Fields, 3KHz to 300GHz," ANSI/IEEE C95.1-1992, Conpyright 1992 by the Institute of Electrical & Electronics Engineers, Inc., New York, New York 10071.

<b>Human Exposure</b>	<b>Uncontrolled Environment General Population</b>
Spatial Peak SAR (Brain)	1.60 mW/g (averaged over a mass of 1g)

Table 3. RF Exposure Limits

Notes:

1. Uncontrolled environments are defined as locations where there is potential exposure of individuals who have no knowledge or control of their potential exposure.

## 2. Summary of Results

Frequency Band(MHz)	EUT position	Conducted Output Power (Average)(dBm)	1g Average (mW/g)	Power Drift (dB)	Amb. Temp (°C)	Verdict
GSM 850	LeftHandSide Touch, Low Channel	32.0	1.43	-0.011	22	PASS
	LeftHandSide Touch, Mid Channel	31.9	1.2	0.072	22	PASS
	LeftHandSide Touch, High Channel	31.8	0.872	0.048	22	PASS
	LeftHandSide Tilt, Low Channel	32.0	0.372	-0.085	22	PASS
	LeftHandSide Tilt, Mid Channel	31.9	0.300	-0.052	22	PASS
	LeftHandSide Tilt, High Channel	31.8	0.210	-0.013	22	PASS
	RightHandSide Touch, Low Channel	32.0	1.15	-0.030	22	PASS
	RightHandSide Touch, Mid Channel	31.9	0.976	-0.135	22	PASS
	RightHandSide Touch, High Channel	31.8	0.707	0.011	22	PASS
	RightHandSide Tilt, Low Channel	32.0	0.355	-0.01	22	PASS
	RightHandSide Tilt, Mid Channel	31.9	0.274	-0.098	22	PASS
	RightHandSide Tilt, High Channel	31.8	0.197	-0.030	22	PASS
	BodyWorn, Low Channel	32.0	0.523	-0.080	22	PASS
	BodyWorn, Mid Channel	31.9	0.398	-0.048	22	PASS
	BodyWorn, High Channel	31.8	0.265	0.00	22	PASS
GSM 1900	LeftHandSide Touch, Low Channel	29.5	0.595	-0.703	22	PASS
	LeftHandSide Touch, Mid Channel	29.6	0.727	-0.196	22	PASS
	LeftHandSide Touch, High Channel	29.6	0.710	-0.033	22	PASS
	LeftHandSide Tilt, Low Channel	29.5	0.109	-0.439	22	PASS
	LeftHandSide Tilt, Mid Channel	29.6	0.142	0.022	22	PASS
	LeftHandSide Tilt, High Channel	29.6	0.142	0.013	22	PASS
	RightHandSide Touch, Low Channel	29.5	0.762	0.135	22	PASS

	<b>RightHandSide Touch, Mid Channel</b>	<b>29.6</b>	<b>0.849</b>	<b>-0.088</b>	<b>22</b>	<b>PASS</b>
	<b>RightHandSide Touch, High Channel</b>	<b>29.6</b>	<b>0.776</b>	<b>-0.169</b>	<b>22</b>	<b>PASS</b>
	<b>RightHandSide Tilt, Low Channel</b>	<b>29.5</b>	<b>0.127</b>	<b>-0.061</b>	<b>22</b>	<b>PASS</b>
	<b>RightHandSide Tilt, Mid Channel</b>	<b>29.6</b>	<b>0.142</b>	<b>-0.045</b>	<b>22</b>	<b>PASS</b>
	<b>RightHandSide Tilt, High Channel</b>	<b>29.6</b>	<b>0.139</b>	<b>-0.070</b>	<b>22</b>	<b>PASS</b>
	<b>BodyWorn, Low Channel</b>	<b>29.5</b>	<b>0.272</b>	<b>-0.102</b>	<b>22</b>	<b>PASS</b>
	<b>BodyWorn, Mid Channel</b>	<b>29.6</b>	<b>0.279</b>	<b>-0.066</b>	<b>22</b>	<b>PASS</b>
	<b>BodyWorn, High Channel</b>	<b>29.6</b>	<b>0.259</b>	<b>-0.00</b>	<b>22</b>	<b>PASS</b>

## Note:

1. In GSM850 band, the low, middle and high channels are CH128/824.2MHz, CH189/836.4MHz and CH251/848.8MHz separately.
2. In GSM1900 band, the low, middle and high channels are CH512/1805.2MHz, CH661/1880.0MHz and CH810/1909.8MHz separately.
3. For the Bodyworn measurements the sample was only placed with the antenna toward the phantom since this position delivers the highest SAR values.

### 3. Instruments List

Instrument	Model	Serial number	No.	Date of last Calibration
Desktop PC	COMPAQ EVO	N/A	GSM-SAR-025	N/A
Dasy 4 software	V 4.5 build 19	N/A	GSM-SAR-001	N/A
Probe	ET3DV6	1774	GSM-SAR-021	2004.10.26
DAE	DAE4	661	GSM-SAR-123	2005.5.27
Phantom	SAM	N/A	GSM-SAR-005	N/A
Robot	RX90L	N/A	GSM-SAR-008	N/A
900MHz system validation dipole	D900V2	184	GSM-SAR-013	2005.8.25
1900MHz system validation dipole	D1900V2	5d028	GSM-SAR-020	2005.8.25
Dielectric probe kit	85070D	US01440168	GSM-SAR-016	2004.12.20
Agilent network analyzer	E5071B	MY42100549	GSM-SAR-007	2004.12.20
Agilent signal generator	E4438	14438CATO-19719	GSM-SAR-008	2004.12.20
Agilent preamplifier	8449B	3008A01921	GSM-SAR-009	2004.12.20
Agilent power meter	E4416A	GB41292095	GSM-SAR-010	2004.12.20
Agilent power sensor	8481h	MY41091234	GSM-SAR-011	2004.12.20
HT CP6100 20N Coupling	6100	SCP301480120	GSM-SAR-012	2004.12.20
R&S Universal radio communication tester	CMU200	103633	GSM-AUD-002	2004.12.20

## 4. Measurements

### 4.1 FCC-OET65-LeftHandSide-Touch-GSM850-Low

Date/Time: 2005-9-15 9:54:28 Date/Time: 2005-9-15 10:03:47

Test Laboratory: SGS-GSM

### FCC-OET65-LeftHandSide-Touch-GSM850-Low

**DUT: GSM50084-Head; Type: Head; Serial: 20050914**

Communication System: GSM850-GSM Mode; Frequency: 824.2 MHz; Duty Cycle: 1:8.3  
Medium: HSL850-Head Medium parameters used (interpolated):  $f = 824.2$  MHz;  $\sigma = 0.866$  mho/m;  $\epsilon_r = 41.8$ ;  $\rho = 1000$  kg/m<sup>3</sup>

Phantom section: Left Section

Measurement Standard: DAS4 (High Precision Assessment)

DASY4 Configuration:

- Probe: ET3DV6 - SN1774; ConvF(6.96, 6.96, 6.96); Calibrated: 2004-10-26
- Sensor-Surface: 4mm (Mechanical Surface Detection)
- Electronics: DAE4 Sn611;
- Phantom: SAM 12; Type: SAM V4.0; Serial: TP-1283
- Measurement SW: DAS4, V4.5 Build 19; Postprocessing SW: SEMCAD, V1.8 Build 146

**Touch position - Low/Area Scan (71x131x1):** Measurement grid: dx=15mm, dy=15mm

Maximum value of SAR (interpolated) = 1.50 mW/g

**Touch position - Low/Zoom Scan (7x7x7) (7x7x7)/Cube 0:** Measurement grid: dx=5mm, dy=5mm, dz=5mm

Reference Value = 11.1 V/m; Power Drift = -0.011 dB  
Peak SAR (extrapolated) = 2.13 W/kg  
**SAR(1 g) = 1.43 mW/g; SAR(10 g) = 0.904 mW/g**  
Maximum value of SAR (measured) = 1.52 mW/g

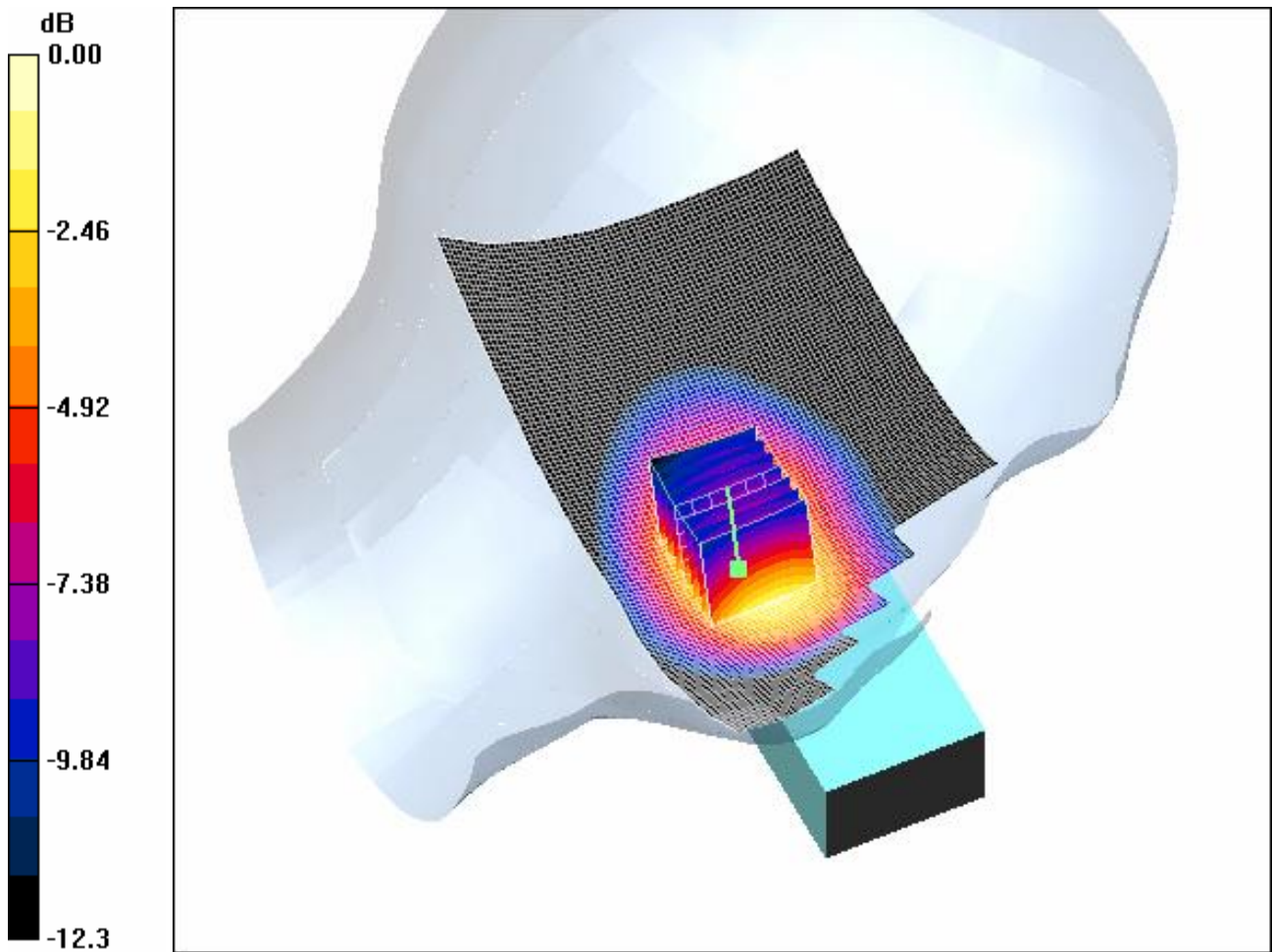

0 dB = 1.52mW/g

#### 4.2 FCC-OET65-LeftHandSide-Touch-GSM850-Mid

Date/Time: 2005-9-15 9:26:32 Date/Time: 2005-9-15 9:36:54

Test Laboratory: SGS-GSM

## **FCC-OET65-LeftHandSide-Touch-GSM850-Mid**

**DUT: GSM50084-Head; Type: Head; Serial: 20050914**

Communication System: GSM850-GSM Mode; Frequency: 836.4 MHz; Duty Cycle: 1:8.3  
Medium: HSL850-Head Medium parameters used (interpolated):  $f = 836.4$  MHz;  $\sigma = 0.878$  mho/m;  $\epsilon_r = 41.7$ ;  $\rho = 1000$  kg/m<sup>3</sup>

Phantom section: Left Section

Measurement Standard: DASY4 (High Precision Assessment)

DASY4 Configuration:

- Probe: ET3DV6 - SN1774; ConvF(6.96, 6.96, 6.96); Calibrated: 2004-10-26
- Sensor-Surface: 4mm (Mechanical Surface Detection)
- Electronics: DAE4 Sn611;
- Phantom: SAM 12; Type: SAM V4.0; Serial: TP-1283
- Measurement SW: DASY4, V4.5 Build 19; Postprocessing SW: SEMCAD, V1.8 Build 146

**Touch position - Middle/Area Scan (71x131x1):** Measurement grid: dx=15mm, dy=15mm

Maximum value of SAR (interpolated) = 1.28 mW/g

**Touch position - Middle/Zoom Scan (7x7x7)/Cube 0:** Measurement grid: dx=5mm, dy=5mm, dz=5mm

Reference Value = 10.1 V/m; Power Drift = 0.072 dB

Peak SAR (extrapolated) = 1.75 W/kg

**SAR(1 g) = 1.2 mW/g; SAR(10 g) = 0.758 mW/g**

Maximum value of SAR (measured) = 1.28 mW/g



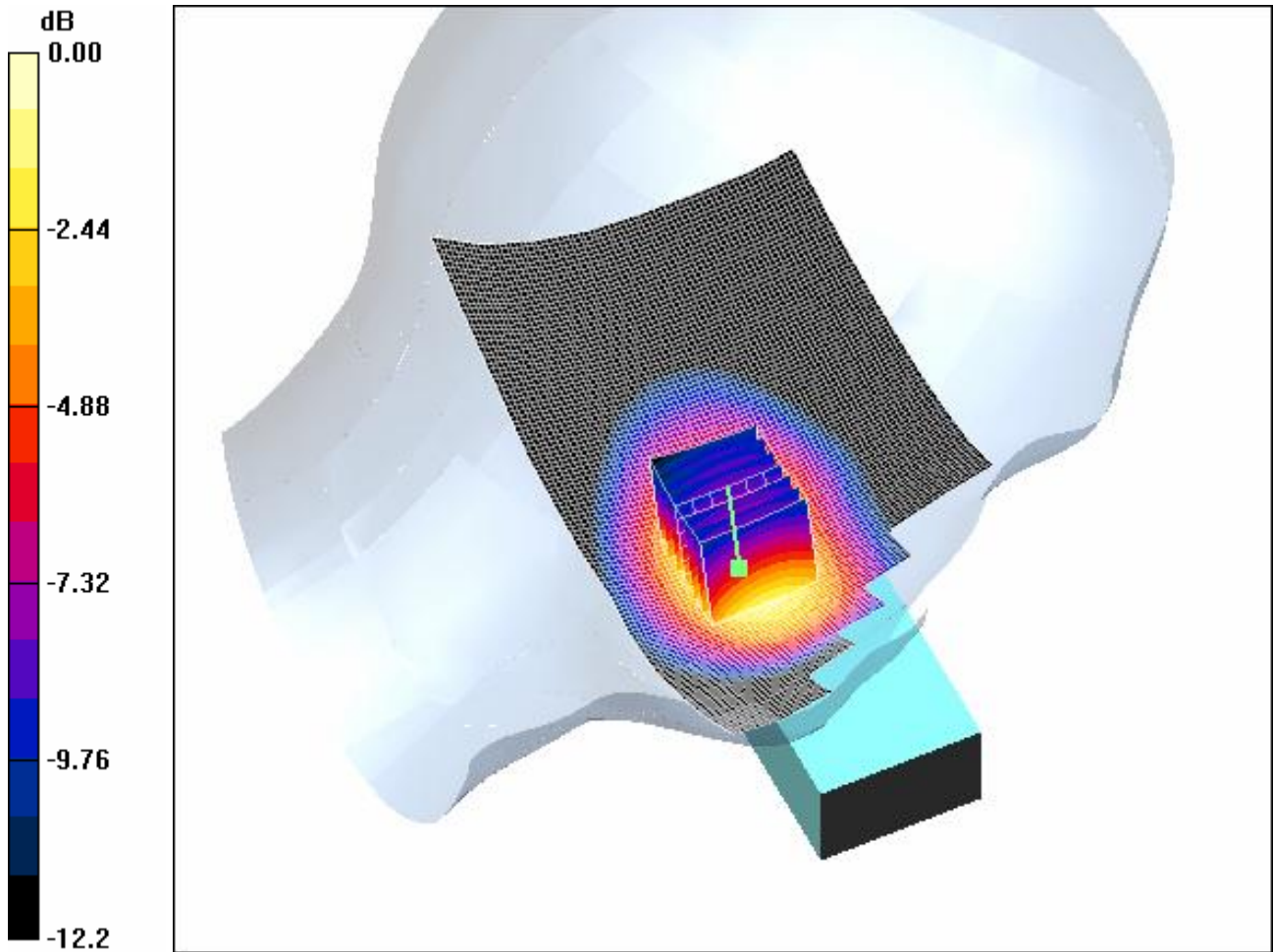

0 dB = 1.28mW/g

#### **4.3 FCC-OET65-LeftHandSide-Touch-GSM850-High**

Date/Time: 2005-9-15 10:22:35 Date/Time: 2005-9-15 10:31:51

Test Laboratory: SGS-GSM

#### **FCC-OET65-LeftHandSide-Touch-GSM850-High**

**DUT: GSM50084-Head; Type: Head; Serial: 20050914**

Communication System: GSM850-GSM Mode; Frequency: 848.8 MHz; Duty Cycle: 1:8.3  
Medium: HSL850-Head Medium parameters used (interpolated):  $f = 848.8$  MHz;  $\sigma = 0.89$

mho/m;  $\epsilon_r = 41.6$ ;  $\rho = 1000 \text{ kg/m}^3$

Phantom section: Left Section

Measurement Standard: DASY4 (High Precision Assessment)

DASY4 Configuration:

- Probe: ET3DV6 - SN1774; ConvF(6.96, 6.96, 6.96); Calibrated: 2004-10-26
- Sensor-Surface: 4mm (Mechanical Surface Detection)
- Electronics: DAE4 Sn611;
- Phantom: SAM 12; Type: SAM V4.0; Serial: TP-1283
- Measurement SW: DASY4, V4.5 Build 19; Postprocessing SW: SEMCAD, V1.8 Build 146

**Touch position - High/Area Scan (71x131x1):** Measurement grid: dx=15mm, dy=15mm

Maximum value of SAR (interpolated) = 0.918 mW/g

**Touch position - High/Zoom Scan (7x7x7) (7x7x7)/Cube 0:** Measurement grid: dx=5mm, dy=5mm, dz=5mm

Reference Value = 8.55 V/m; Power Drift = 0.048 dB

Peak SAR (extrapolated) = 1.28 W/kg

**SAR(1 g) = 0.872 mW/g; SAR(10 g) = 0.549 mW/g**

Maximum value of SAR (measured) = 0.928 mW/g

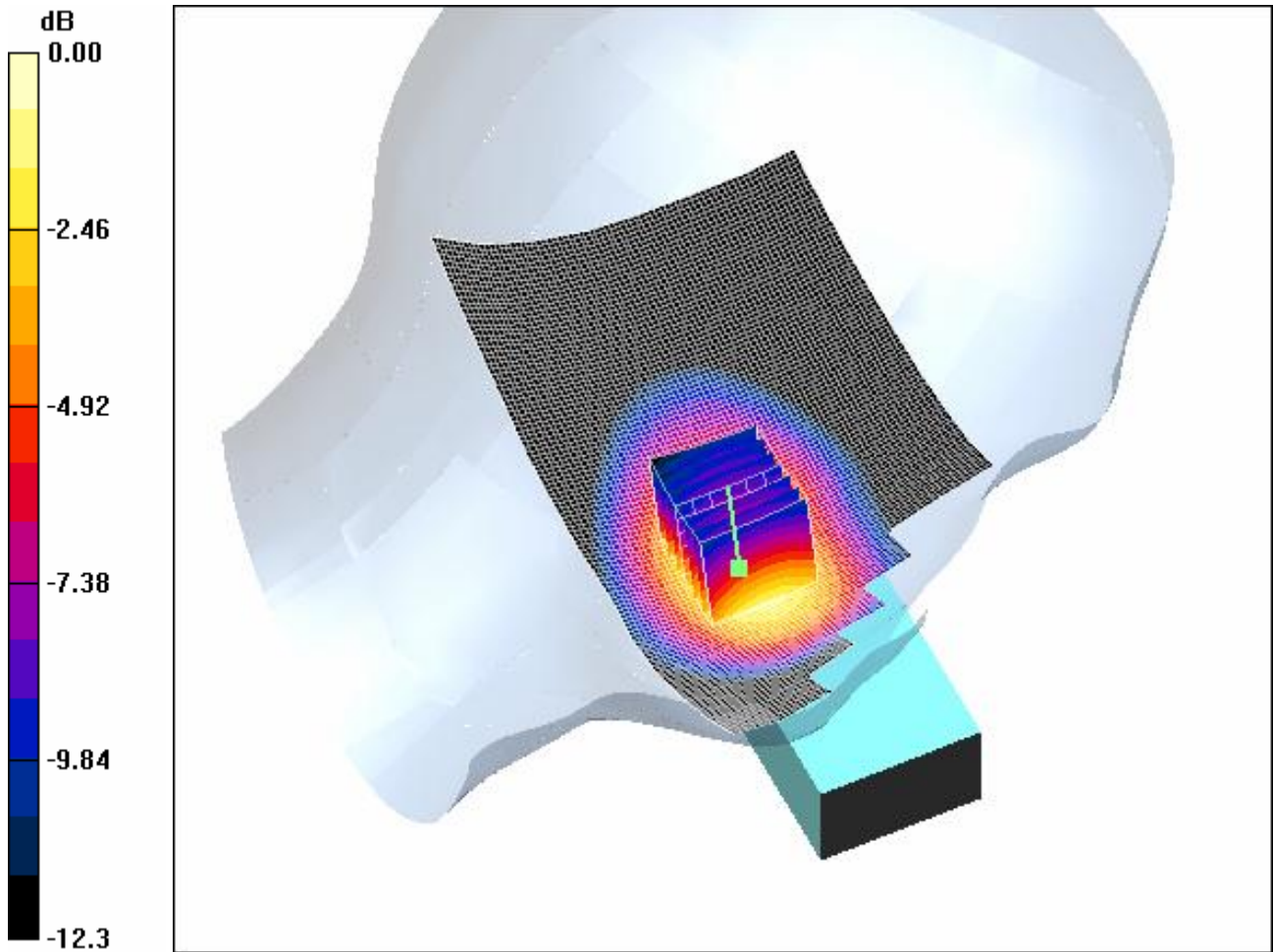

0 dB = 0.928mW/g

#### **4.4 FCC-OET65-LeftHandSide-Tilt-GSM850-Low**

Date/Time: 2005-9-15 11:08:34 Date/Time: 2005-9-15 11:17:50

Test Laboratory: SGS-GSM

#### **FCC-OET65-LeftHandSide-Tilt-GSM850-Low**

**DUT: GSM50084-Head; Type: Head; Serial: 20050914**

Communication System: GSM850-GSM Mode; Frequency: 824.2 MHz; Duty Cycle: 1:8.3  
Medium: HSL850-Head Medium parameters used (interpolated):  $f = 824.2$  MHz;  $\sigma = 0.866$

mho/m;  $\epsilon_r = 41.8$ ;  $\rho = 1000 \text{ kg/m}^3$

Phantom section: Left Section

Measurement Standard: DASY4 (High Precision Assessment)

DASY4 Configuration:

- Probe: ET3DV6 - SN1774; ConvF(6.96, 6.96, 6.96); Calibrated: 2004-10-26
- Sensor-Surface: 4mm (Mechanical Surface Detection)
- Electronics: DAE4 Sn611;
- Phantom: SAM 12; Type: SAM V4.0; Serial: TP-1283
- Measurement SW: DASY4, V4.5 Build 19; Postprocessing SW: SEMCAD, V1.8 Build 146

**Tilt position - Low/Area Scan (71x131x1):** Measurement grid: dx=15mm, dy=15mm  
Maximum value of SAR (interpolated) = 0.397 mW/g

**Tilt position - Low/Zoom Scan (7x7x7)/Cube 0:** Measurement grid: dx=5mm,  
dy=5mm, dz=5mm

Reference Value = 13.2 V/m; Power Drift = -0.085 dB

Peak SAR (extrapolated) = 0.475 W/kg

**SAR(1 g) = 0.372 mW/g; SAR(10 g) = 0.270 mW/g**

Maximum value of SAR (measured) = 0.394 mW/g

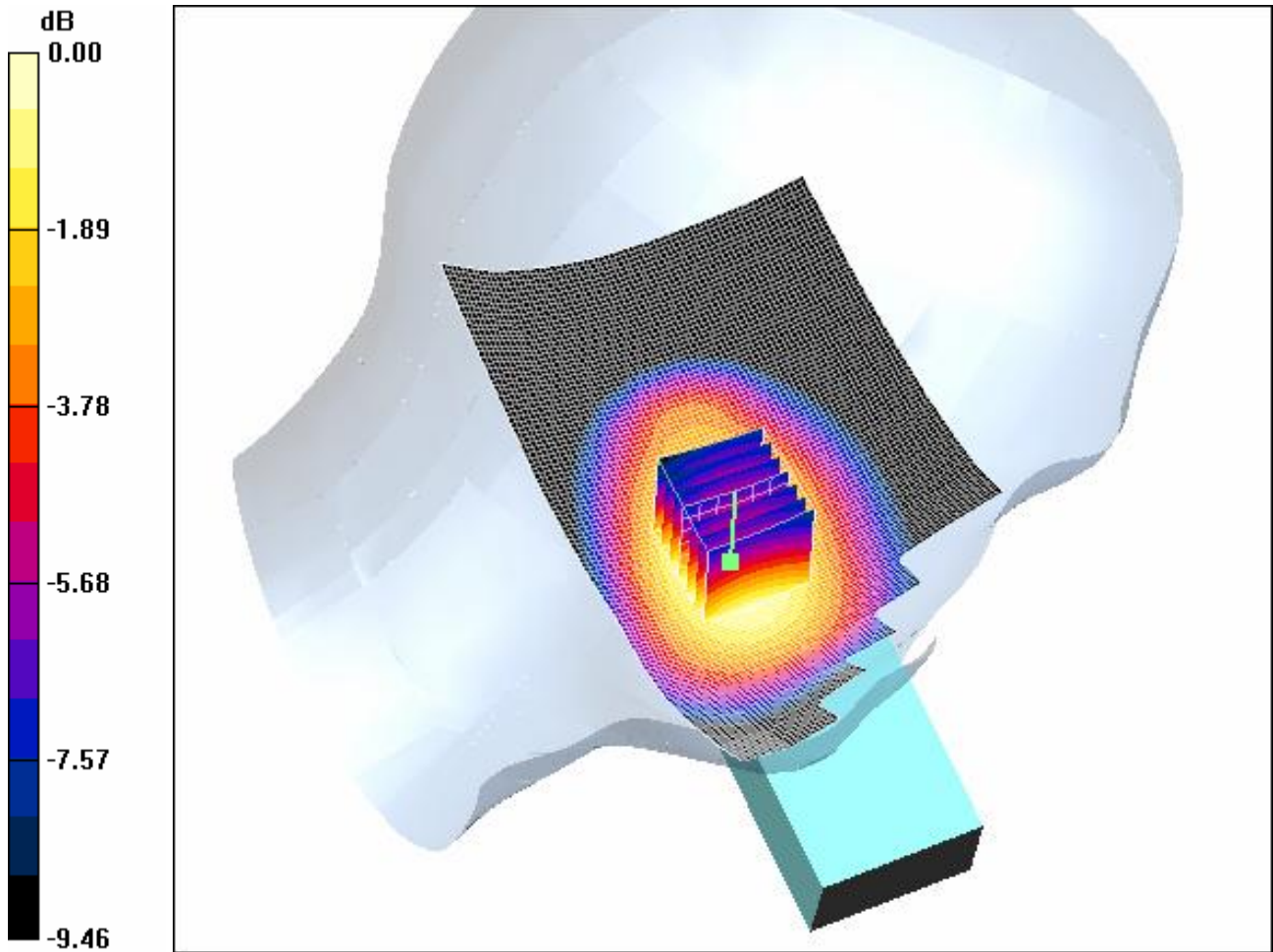

0 dB = 0.394mW/g

#### **4.5 FCC-OET65-LeftHandSide-Tilt-GSM850-Mid**

Date/Time: 2005-9-15 11:45:19 Date/Time: 2005-9-15 11:54:35

Test Laboratory: SGS-GSM

#### **FCC-OET65-LeftHandSide-Tilt-GSM850-Mid**

**DUT: GSM50084-Head; Type: Head; Serial: 20050914**

Communication System: GSM850-GSM Mode; Frequency: 836.4 MHz; Duty Cycle: 1:8.3  
Medium: HSL850-Head Medium parameters used (interpolated):  $f = 836.4$  MHz;  $\sigma = 0.878$

mho/m;  $\epsilon_r = 41.7$ ;  $\rho = 1000 \text{ kg/m}^3$

Phantom section: Left Section

Measurement Standard: DAS4 (High Precision Assessment)

DAS4 Configuration:

- Probe: ET3DV6 - SN1774; ConvF(6.96, 6.96, 6.96); Calibrated: 2004-10-26
- Sensor-Surface: 4mm (Mechanical Surface Detection)
- Electronics: DAE4 Sn611;
- Phantom: SAM 12; Type: SAM V4.0; Serial: TP-1283
- Measurement SW: DAS4, V4.5 Build 19; Postprocessing SW: SEMCAD, V1.8 Build 146

**Tilt position - Middle/Area Scan (71x131x1):** Measurement grid: dx=15mm, dy=15mm

Maximum value of SAR (interpolated) = 0.319 mW/g

**Tilt position - Middle/Zoom Scan (7x7x7) (7x7x7)/Cube 0:** Measurement grid: dx=5mm, dy=5mm, dz=5mm

Reference Value = 11.6 V/m; Power Drift = -0.052 dB

Peak SAR (extrapolated) = 0.389 W/kg

**SAR(1 g) = 0.300 mW/g; SAR(10 g) = 0.218 mW/g**

Maximum value of SAR (measured) = 0.316 mW/g

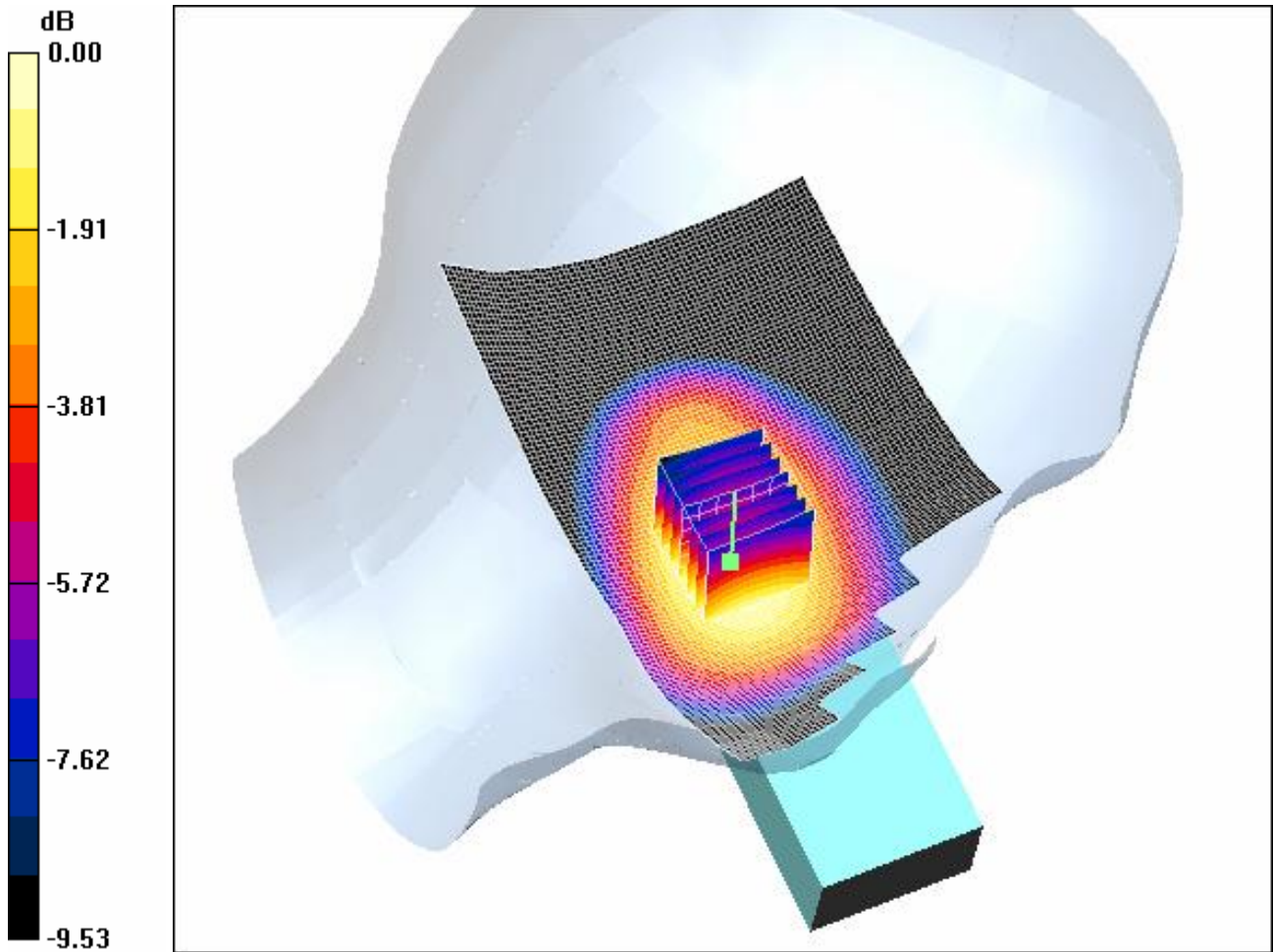

0 dB = 0.316mW/g

#### **4.6 FCC-OET65-LeftHandSide-Tilt-GSM850-High**

Date/Time: 2005-9-15 12:15:02 Date/Time: 2005-9-15 12:24:19

Test Laboratory: SGS-GSM

#### **FCC-OET65-LeftHandSide-Tilt-GSM850-High**

**DUT: GSM50084-Head; Type: Head; Serial: 20050914**

Communication System: GSM850-GSM Mode; Frequency: 848.8 MHz; Duty Cycle: 1:8.3  
Medium: HSL850-Head Medium parameters used (interpolated):  $f = 848.8$  MHz;  $\sigma = 0.89$

mho/m;  $\epsilon_r = 41.6$ ;  $\rho = 1000 \text{ kg/m}^3$

Phantom section: Left Section

Measurement Standard: DAS4 (High Precision Assessment)

DAS4 Configuration:

- Probe: ET3DV6 - SN1774; ConvF(6.96, 6.96, 6.96); Calibrated: 2004-10-26
- Sensor-Surface: 4mm (Mechanical Surface Detection)
- Electronics: DAE4 Sn611;
- Phantom: SAM 12; Type: SAM V4.0; Serial: TP-1283
- Measurement SW: DAS4, V4.5 Build 19; Postprocessing SW: SEMCAD, V1.8 Build 146

**Tilt position - High/Area Scan (71x131x1):** Measurement grid: dx=15mm, dy=15mm  
Maximum value of SAR (interpolated) = 0.221 mW/g

**Tilt position - High/Zoom Scan (7x7x7) (7x7x7)/Cube 0:** Measurement grid:  
dx=5mm, dy=5mm, dz=5mm

Reference Value = 9.68 V/m; Power Drift = -0.013 dB

Peak SAR (extrapolated) = 0.270 W/kg

**SAR(1 g) = 0.210 mW/g; SAR(10 g) = 0.152 mW/g**

Maximum value of SAR (measured) = 0.222 mW/g



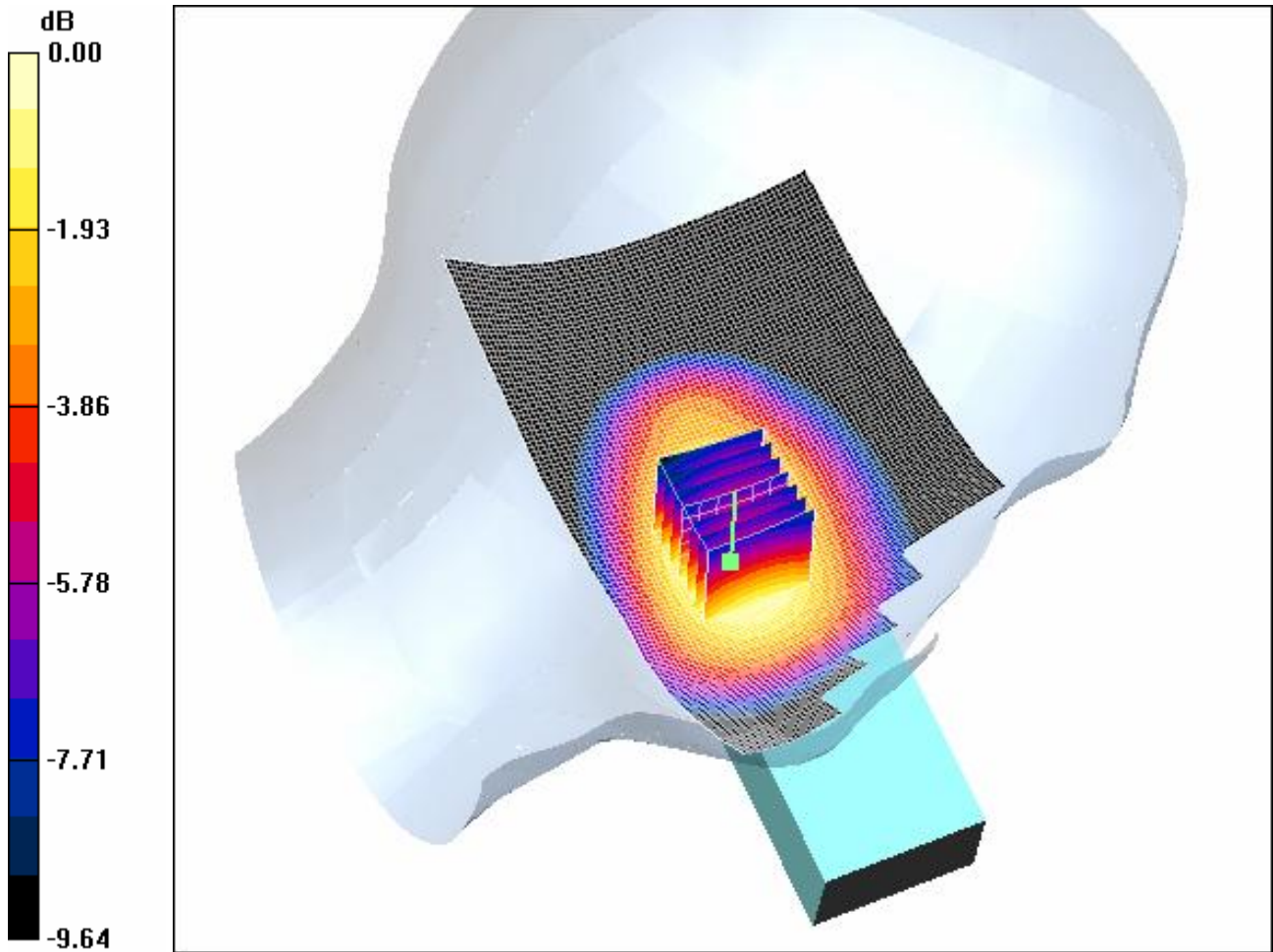

0 dB = 0.222mW/g

#### **4.7 FCC-OET65-RightHandSide-Touch-GSM850-Low**

Date/Time: 2005-9-15 13:43:33 Date/Time: 2005-9-15 13:53:12

Test Laboratory: SGS-GSM

#### **FCC-OET65-RightHandSide-Touch-GSM850-Low**

**DUT: GSM50084-Head; Type: Head; Serial: 20050914**

Communication System: GSM850-GSM Mode; Frequency: 824.2 MHz; Duty Cycle: 1:8.3  
Medium: HSL850-Head Medium parameters used (interpolated):  $f = 824.2$  MHz;  $\sigma = 0.866$

mho/m;  $\epsilon_r = 41.8$ ;  $\rho = 1000 \text{ kg/m}^3$

Phantom section: Right Section

Measurement Standard: DAS4 (High Precision Assessment)

DAS4 Configuration:

- Probe: ET3DV6 - SN1774; ConvF(6.96, 6.96, 6.96); Calibrated: 2004-10-26
- Sensor-Surface: 4mm (Mechanical Surface Detection)
- Electronics: DAE4 Sn611;
- Phantom: SAM 12; Type: SAM V4.0; Serial: TP-1283
- Measurement SW: DAS4, V4.5 Build 19; Postprocessing SW: SEMCAD, V1.8 Build 146

**Touch position - Low/Area Scan (71x131x1):** Measurement grid: dx=15mm, dy=15mm

Maximum value of SAR (interpolated) = 1.20 mW/g

**Touch position - Low/Zoom Scan (7x7x7) (7x7x7)/Cube 0:** Measurement grid: dx=5mm, dy=5mm, dz=5mm

Reference Value = 12.0 V/m; Power Drift = -0.030 dB

Peak SAR (extrapolated) = 1.76 W/kg

**SAR(1 g) = 1.15 mW/g; SAR(10 g) = 0.750 mW/g**

Maximum value of SAR (measured) = 1.24 mW/g

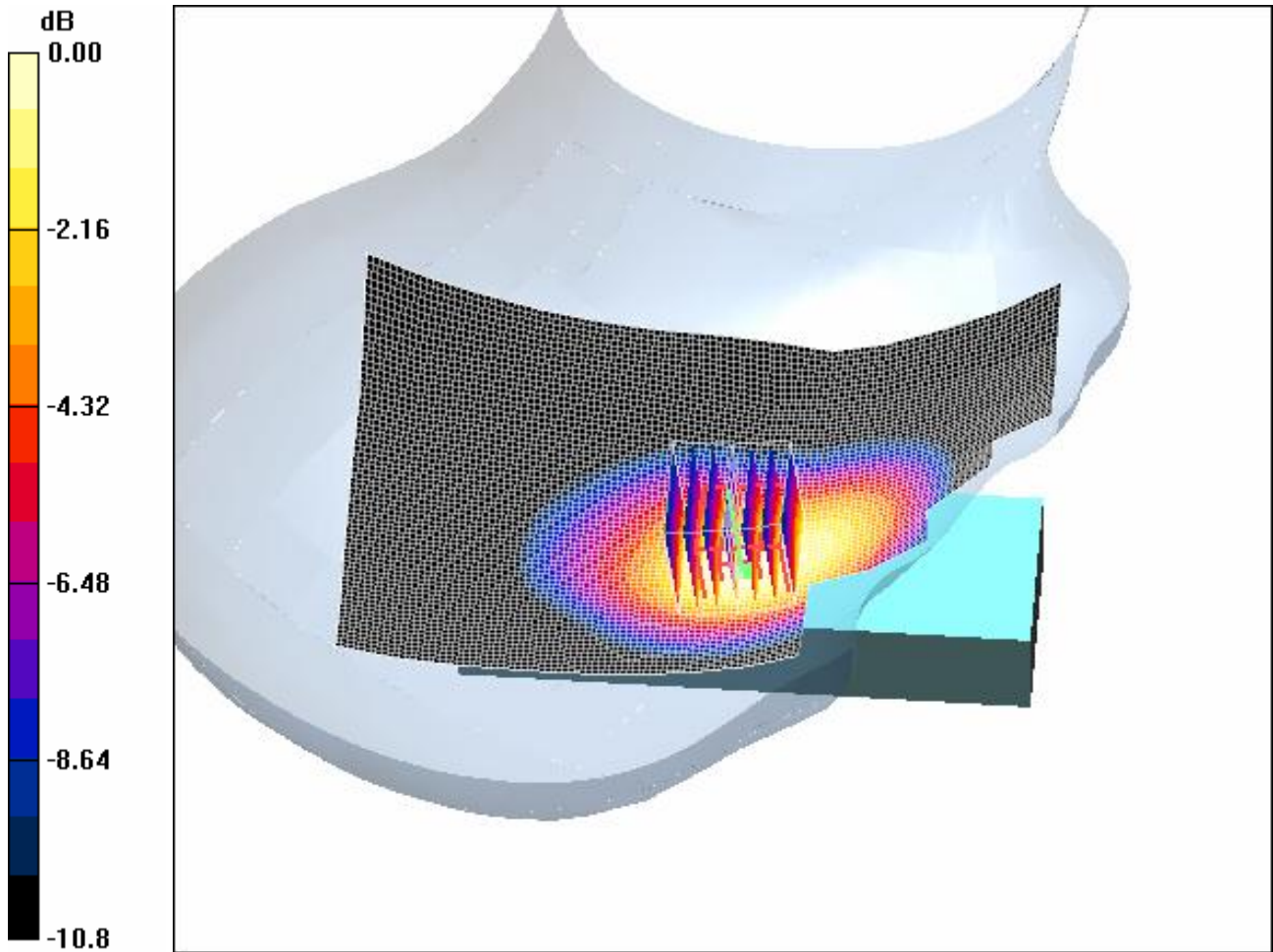

0 dB = 1.24mW/g

#### **4.8 FCC-OET65-RightHandSide-Touch-GSM850-Mid**

Date/Time: 2005-9-15 13:17:04 Date/Time: 2005-9-15 13:26:41

Test Laboratory: SGS-GSM

#### **FCC-OET65-RightHandSide-Touch-GSM850-Mid**

**DUT: GSM50084-Head; Type: Head; Serial: 20050914**

Communication System: GSM850-GSM Mode; Frequency: 836.4 MHz; Duty Cycle: 1:8.3  
Medium: HSL850-Head Medium parameters used (interpolated):  $f = 836.4$  MHz;  $\sigma = 0.878$

mho/m;  $\epsilon_r = 41.7$ ;  $\rho = 1000 \text{ kg/m}^3$

Phantom section: Right Section

Measurement Standard: DAS4 (High Precision Assessment)

DAS4 Configuration:

- Probe: ET3DV6 - SN1774; ConvF(6.96, 6.96, 6.96); Calibrated: 2004-10-26
- Sensor-Surface: 4mm (Mechanical Surface Detection)
- Electronics: DAE4 Sn611;
- Phantom: SAM 12; Type: SAM V4.0; Serial: TP-1283
- Measurement SW: DAS4, V4.5 Build 19; Postprocessing SW: SEMCAD, V1.8 Build 146

**Touch position - Middle/Area Scan (71x131x1):** Measurement grid: dx=15mm, dy=15mm

Maximum value of SAR (interpolated) = 1.03 mW/g

**Touch position - Middle/Zoom Scan (7x7x7)/Cube 0:** Measurement grid: dx=5mm, dy=5mm, dz=5mm

Reference Value = 10.8 V/m; Power Drift = 0.135 dB

Peak SAR (extrapolated) = 1.46 W/kg

**SAR(1 g) = 0.976 mW/g; SAR(10 g) = 0.636 mW/g**

Maximum value of SAR (measured) = 1.05 mW/g

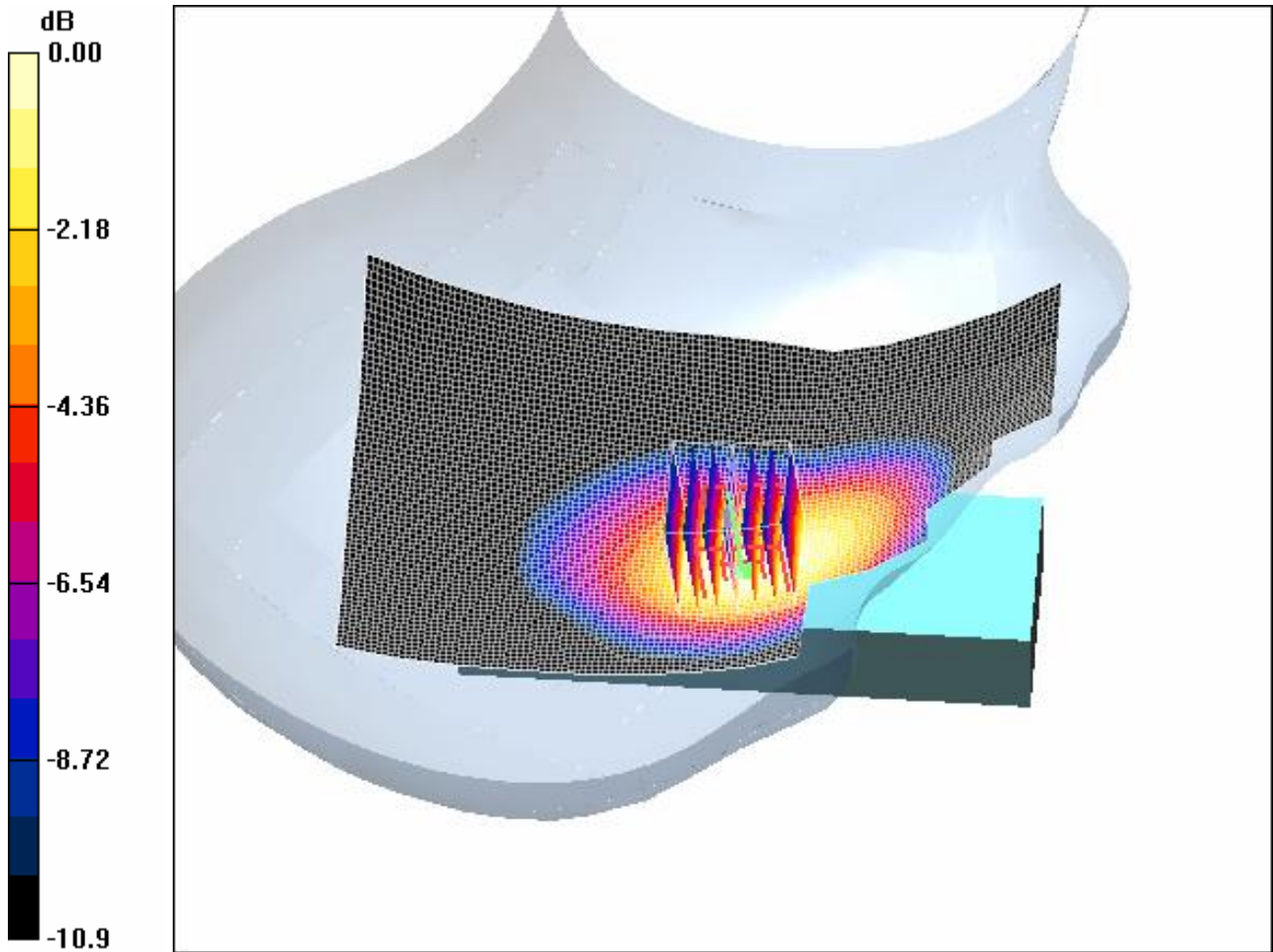

0 dB = 1.05mW/g

#### **4.9 FCC-OET65-RightHandSide-Touch-GSM850-High**

Date/Time: 2005-9-15 14:25:53 Date/Time: 2005-9-15 14:35:31

Test Laboratory: SGS-GSM

#### **FCC-OET65-RightHandSide-Touch-GSM850-High**

**DUT: GSM50084-Head; Type: Head; Serial: 20050914**

Communication System: GSM850-GSM Mode; Frequency: 848.8 MHz; Duty Cycle: 1:8.3  
Medium: HSL850-Head Medium parameters used (interpolated):  $f = 848.8$  MHz;  $\sigma = 0.89$

mho/m;  $\epsilon_r = 41.6$ ;  $\rho = 1000 \text{ kg/m}^3$

Phantom section: Right Section

Measurement Standard: DASY4 (High Precision Assessment)

DASY4 Configuration:

- Probe: ET3DV6 - SN1774; ConvF(6.96, 6.96, 6.96); Calibrated: 2004-10-26
- Sensor-Surface: 4mm (Mechanical Surface Detection)
- Electronics: DAE4 Sn611;
- Phantom: SAM 12; Type: SAM V4.0; Serial: TP-1283
- Measurement SW: DASY4, V4.5 Build 19; Postprocessing SW: SEMCAD, V1.8 Build 146

**Touch position - High/Area Scan (71x131x1):** Measurement grid: dx=15mm, dy=15mm

Maximum value of SAR (interpolated) = 0.736 mW/g

**Touch position - High/Zoom Scan (7x7x7) (7x7x7)/Cube 0:** Measurement grid: dx=5mm, dy=5mm, dz=5mm

Reference Value = 9.27 V/m; Power Drift = 0.011 dB

Peak SAR (extrapolated) = 1.06 W/kg

**SAR(1 g) = 0.707 mW/g; SAR(10 g) = 0.459 mW/g**

Maximum value of SAR (measured) = 0.760 mW/g

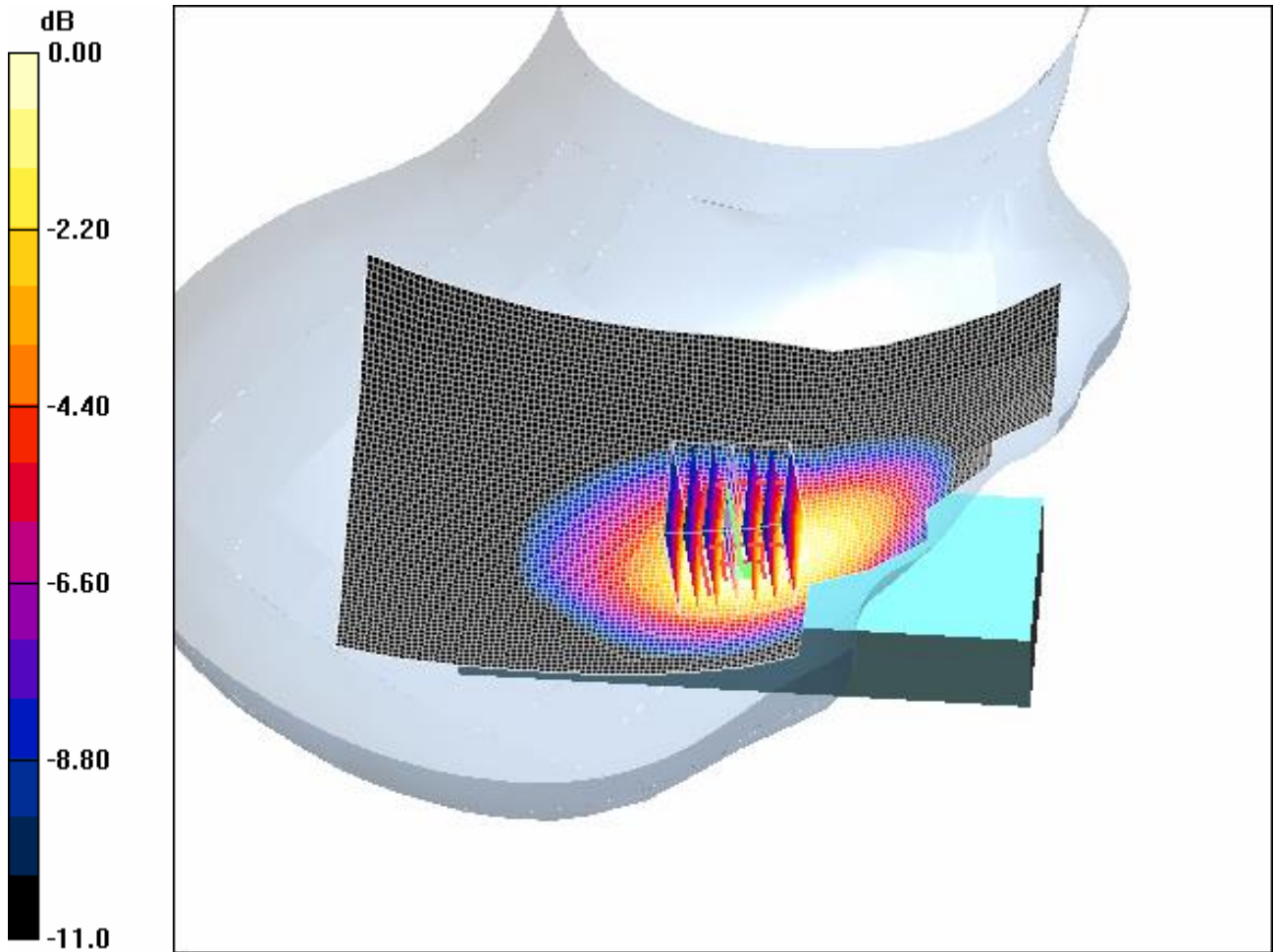

0 dB = 0.760mW/g

#### **4.10 FCC-OET65-RightHandSide-Tilt-GSM850-Low**

Date/Time: 2005-9-15 15:37:52 Date/Time: 2005-9-15 15:47:27

Test Laboratory: SGS-GSM

#### **FCC-OET65-RightHandSide-Tilt-GSM850-Low**

**DUT: GSM50084-Head; Type: Head; Serial: 20050914**

Communication System: GSM850-GSM Mode; Frequency: 824.2 MHz; Duty Cycle: 1:8.3  
Medium: HSL850-Head Medium parameters used (interpolated):  $f = 824.2$  MHz;  $\sigma = 0.866$

mho/m;  $\epsilon_r = 41.8$ ;  $\rho = 1000 \text{ kg/m}^3$

Phantom section: Right Section

Measurement Standard: DASY4 (High Precision Assessment)

DASY4 Configuration:

- Probe: ET3DV6 - SN1774; ConvF(6.96, 6.96, 6.96); Calibrated: 2004-10-26
- Sensor-Surface: 4mm (Mechanical Surface Detection)
- Electronics: DAE4 Sn611;
- Phantom: SAM 12; Type: SAM V4.0; Serial: TP-1283
- Measurement SW: DASY4, V4.5 Build 19; Postprocessing SW: SEMCAD, V1.8 Build 146

**Tilt position - Low/Area Scan (71x131x1):** Measurement grid: dx=15mm, dy=15mm  
Maximum value of SAR (interpolated) = 0.372 mW/g

**Tilt position - Low/Zoom Scan (7x7x7) (7x7x7)/Cube 0:** Measurement grid:  
dx=5mm, dy=5mm, dz=5mm

Reference Value = 14.2 V/m; Power Drift = -0.01 dB

Peak SAR (extrapolated) = 0.461 W/kg

**SAR(1 g) = 0.355 mW/g; SAR(10 g) = 0.258 mW/g**

Maximum value of SAR (measured) = 0.378 mW/g



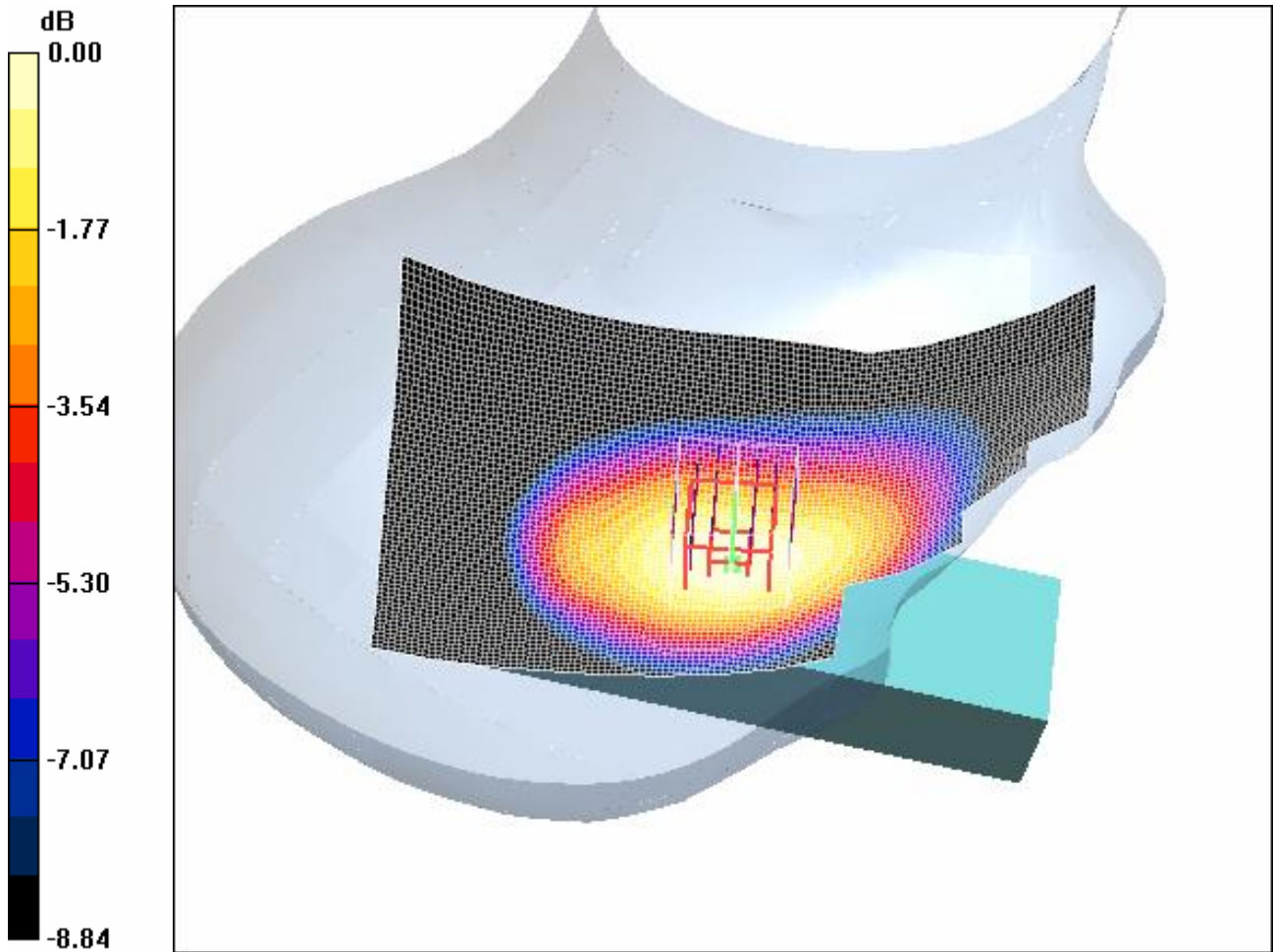

0 dB = 0.378mW/g

#### **4.11 FCC-OET65-RightHandSide-Tilt-GSM850-Mid**

Date/Time: 2005-9-15 15:11:49 Date/Time: 2005-9-15 15:21:26

Test Laboratory: SGS-GSM

#### **FCC-OET65-RightHandSide-Tilt-GSM850-Mid**

**DUT: GSM50084-Head; Type: Head; Serial: 20050914**

Communication System: GSM850-GSM Mode; Frequency: 836.4 MHz; Duty Cycle: 1:8.3  
Medium: HSL850-Head Medium parameters used (interpolated):  $f = 836.4$  MHz;  $\sigma = 0.878$

mho/m;  $\epsilon_r = 41.7$ ;  $\rho = 1000 \text{ kg/m}^3$

Phantom section: Right Section

Measurement Standard: DAS4 (High Precision Assessment)

DAS4 Configuration:

- Probe: ET3DV6 - SN1774; ConvF(6.96, 6.96, 6.96); Calibrated: 2004-10-26
- Sensor-Surface: 4mm (Mechanical Surface Detection)
- Electronics: DAE4 Sn611;
- Phantom: SAM 12; Type: SAM V4.0; Serial: TP-1283
- Measurement SW: DAS4, V4.5 Build 19; Postprocessing SW: SEMCAD, V1.8 Build 146

**Tilt position - Middle/Area Scan (71x131x1):** Measurement grid: dx=15mm, dy=15mm

Maximum value of SAR (interpolated) = 0.288 mW/g

**Tilt position - Middle/Zoom Scan (7x7x7)/Cube 0:** Measurement grid: dx=5mm, dy=5mm, dz=5mm

Reference Value = 12.5 V/m; Power Drift = -0.098 dB

Peak SAR (extrapolated) = 0.355 W/kg

**SAR(1 g) = 0.274 mW/g; SAR(10 g) = 0.199 mW/g**

Maximum value of SAR (measured) = 0.293 mW/g

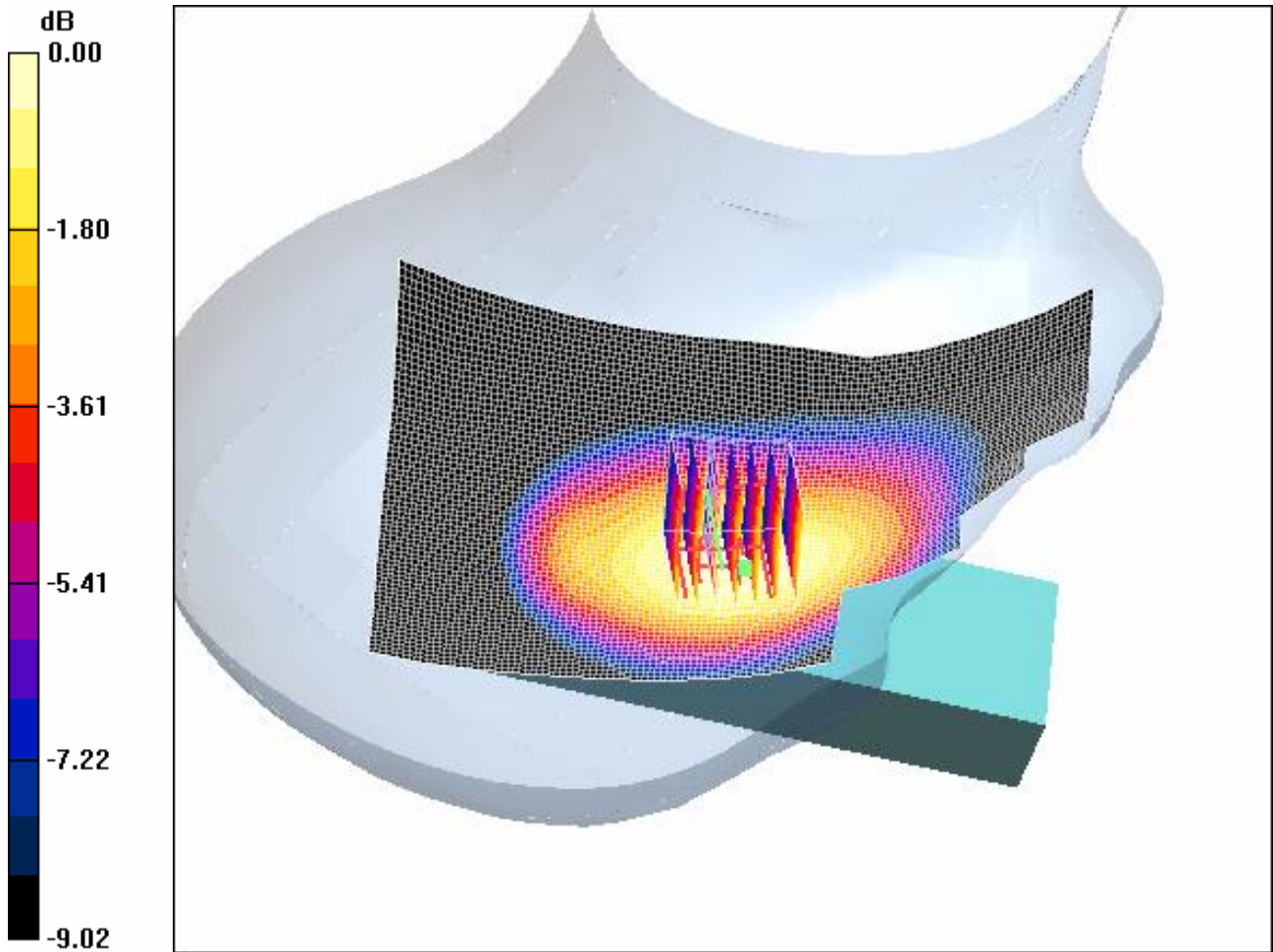

0 dB = 0.293mW/g

#### 4.12 FCC-OET65-RightHandSide-Tilt-GSM850-High

Date/Time: 2005-9-15 16:04:31 Date/Time: 2005-9-15 16:14:07

Test Laboratory: SGS-GSM

#### FCC-OET65-RightHandSide-Tilt-GSM850-High

DUT: GSM50084-Head; Type: Head; Serial: 20050914

Communication System: GSM850-GSM Mode; Frequency: 848.8 MHz; Duty Cycle: 1:8.3  
Medium: HSL850-Head Medium parameters used (interpolated):  $f = 848.8$  MHz;  $\sigma = 0.89$

mho/m;  $\epsilon_r = 41.6$ ;  $\rho = 1000 \text{ kg/m}^3$

Phantom section: Right Section

Measurement Standard: DASY4 (High Precision Assessment)

DASY4 Configuration:

- Probe: ET3DV6 - SN1774; ConvF(6.96, 6.96, 6.96); Calibrated: 2004-10-26
- Sensor-Surface: 4mm (Mechanical Surface Detection)
- Electronics: DAE4 Sn611;
- Phantom: SAM 12; Type: SAM V4.0; Serial: TP-1283
- Measurement SW: DASY4, V4.5 Build 19; Postprocessing SW: SEMCAD, V1.8 Build 146

**Tilt position - High/Area Scan (71x131x1):** Measurement grid: dx=15mm, dy=15mm  
Maximum value of SAR (interpolated) = 0.206 mW/g

**Tilt position - High/Zoom Scan (7x7x7) (7x7x7)/Cube 0:** Measurement grid:  
dx=5mm, dy=5mm, dz=5mm

Reference Value = 10.5 V/m; Power Drift = -0.030 dB

Peak SAR (extrapolated) = 0.254 W/kg

**SAR(1 g) = 0.197 mW/g; SAR(10 g) = 0.143 mW/g**

Maximum value of SAR (measured) = 0.209 mW/g

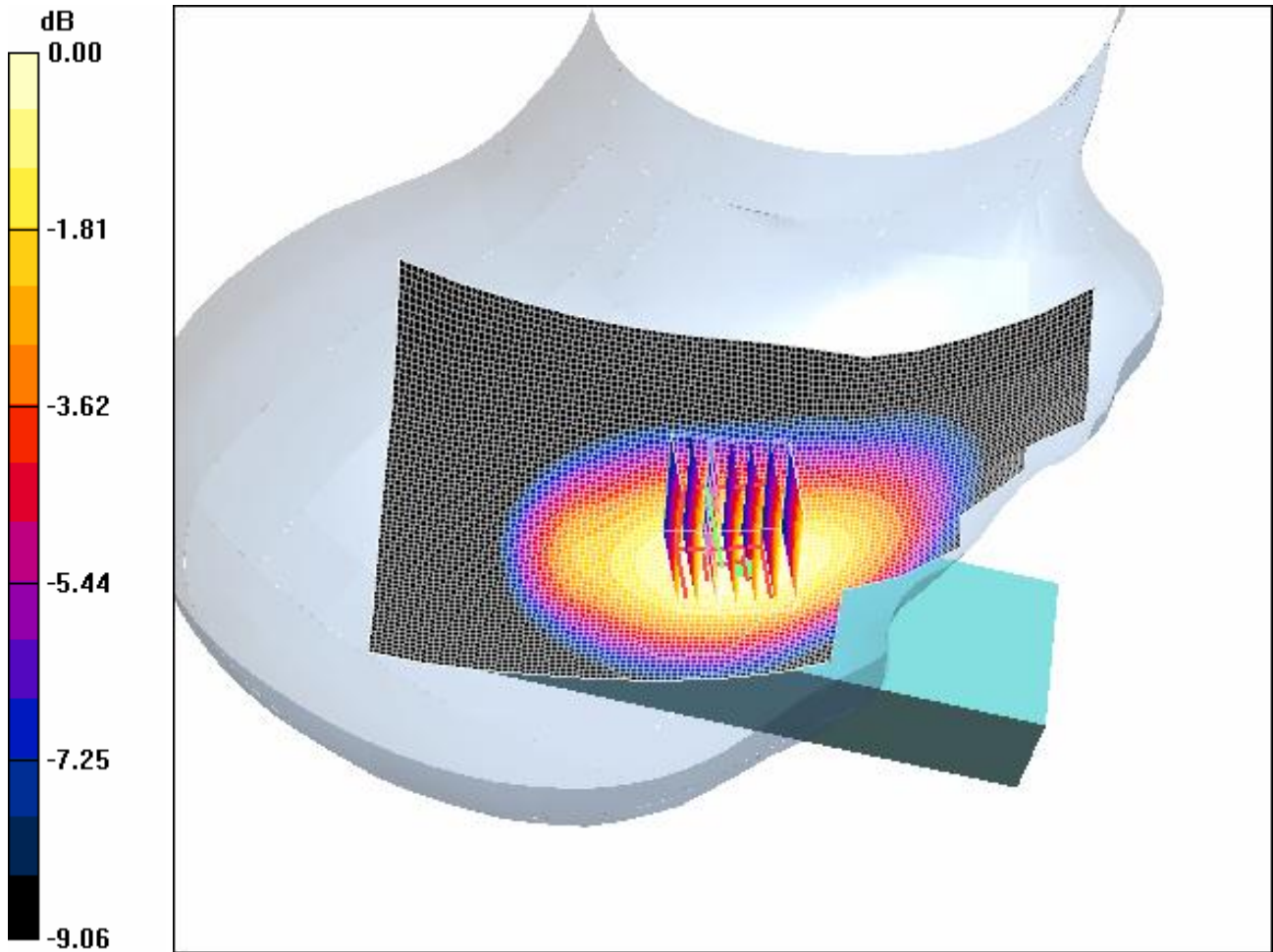

0 dB = 0.209mW/g

#### **4.13 FCC-OET65-Body-Worn-GSM850-Low**

Date/Time: 2005-9-21 16:02:03 Date/Time: 2005-9-21 16:07:39

Test Laboratory: SGS-GSM

#### **FCC-OET65-Body-Worn-GSM850-Low**

**DUT: GSM50084-Body; Type: Body; Serial: 20050921**

Communication System: GSM850-GSM Mode; Frequency: 824.2 MHz; Duty Cycle: 1:8.3  
Medium: HSL850-Body Medium parameters used:  $f = 824.2$  MHz;  $\sigma = 0.984$  mho/m;  $\epsilon_r =$

52.6;  $\rho = 1000 \text{ kg/m}^3$

Phantom section: Flat Section

Measurement Standard: DASY4 (High Precision Assessment)

DASY4 Configuration:

- Probe: ET3DV6 - SN1774; ConvF(6.65, 6.65, 6.65); Calibrated: 2004-10-26
- Sensor-Surface: 4mm (Mechanical Surface Detection)
- Electronics: DAE4 Sn611;
- Phantom: SAM 12; Type: SAM V4.0; Serial: TP-1283
- Measurement SW: DASY4, V4.5 Build 19; Postprocessing SW: SEMCAD, V1.8 Build 146

**Body Worn - Low/Area Scan (51x91x1):** Measurement grid: dx=15mm, dy=15mm  
Maximum value of SAR (interpolated) = 0.565 mW/g

**Body Worn - Low/Zoom Scan (7x7x7) (7x7x7)/Cube 0:** Measurement grid:  
dx=5mm, dy=5mm, dz=5mm

Reference Value = 19.3 V/m; Power Drift = -0.080 dB

Peak SAR (extrapolated) = 0.701 W/kg

**SAR(1 g) = 0.523 mW/g; SAR(10 g) = 0.362 mW/g**

Maximum value of SAR (measured) = 0.559 mW/g

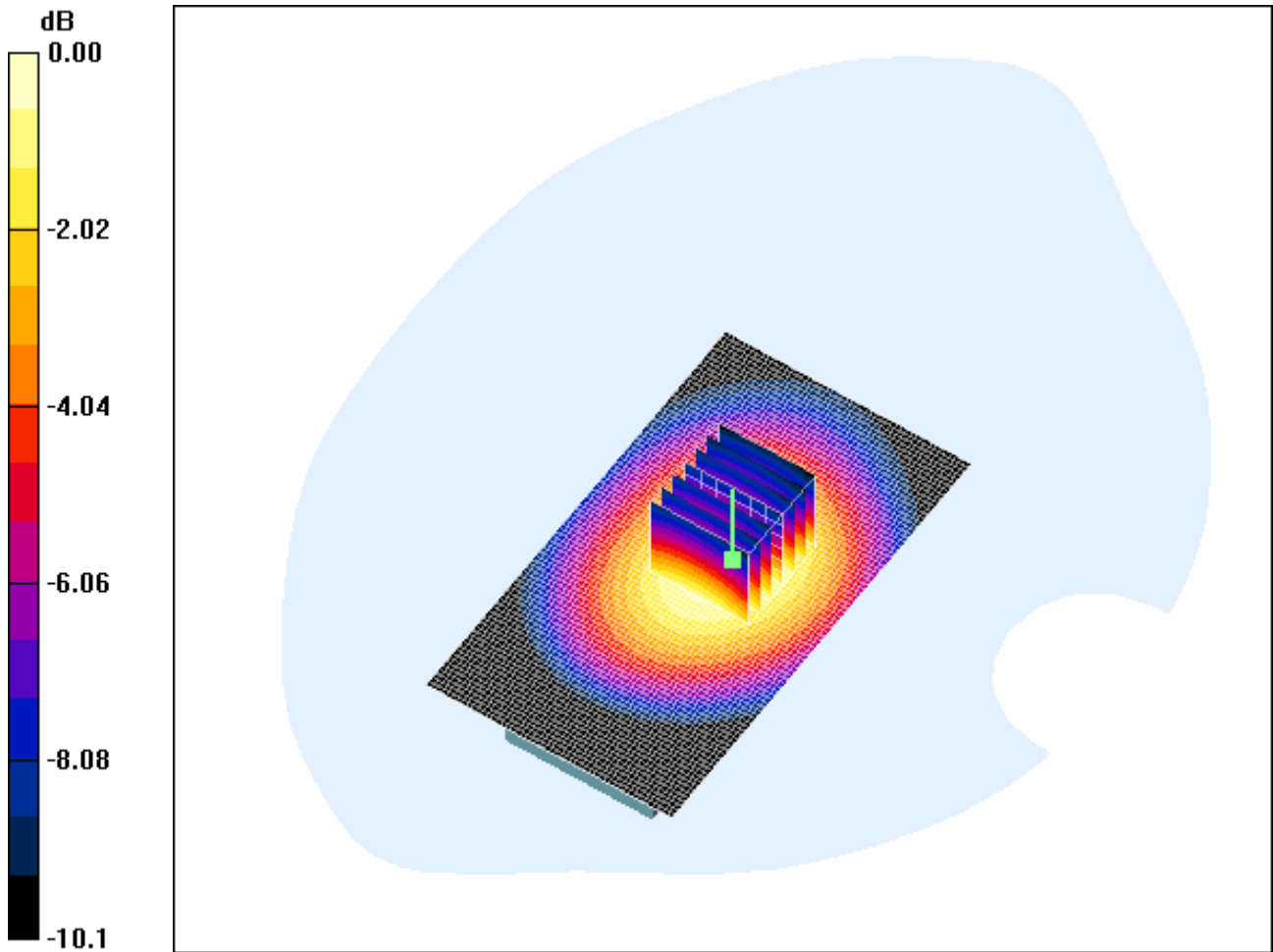

0 dB = 0.559mW/g

#### 4.14 FCC-OET65-Body-Worn-GSM850-Mid

Date/Time: 2005-9-21 15:14:08 Date/Time: 2005-9-21 15:19:42

Test Laboratory: SGS-GSM

#### FCC-OET65-Body-Worn-GSM850-Mid

DUT: GSM50084-Body; Type: Body; Serial: 20050921

Communication System: GSM850-GSM Mode; Frequency: 836.4 MHz; Duty Cycle: 1:8.3  
Medium: HSL850-Body Medium parameters used:  $f = 836.4$  MHz;  $\sigma = 0.998$  mho/m;  $\epsilon_r =$

52.5;  $\rho = 1000 \text{ kg/m}^3$

Phantom section: Flat Section

Measurement Standard: DASY4 (High Precision Assessment)

DASY4 Configuration:

- Probe: ET3DV6 - SN1774; ConvF(6.65, 6.65, 6.65); Calibrated: 2004-10-26
- Sensor-Surface: 4mm (Mechanical Surface Detection)
- Electronics: DAE4 Sn611;
- Phantom: SAM 12; Type: SAM V4.0; Serial: TP-1283
- Measurement SW: DASY4, V4.5 Build 19; Postprocessing SW: SEMCAD, V1.8 Build 146

**Body Worn - Middle/Area Scan (51x91x1):** Measurement grid: dx=15mm, dy=15mm  
Maximum value of SAR (interpolated) = 0.432 mW/g

**Body Worn - Middle/Zoom Scan (7x7x7)/Cube 0:** Measurement grid: dx=5mm, dy=5mm, dz=5mm

Reference Value = 16.5 V/m; Power Drift = -0.048 dB

Peak SAR (extrapolated) = 0.544 W/kg

**SAR(1 g) = 0.398 mW/g; SAR(10 g) = 0.275 mW/g**

Maximum value of SAR (measured) = 0.426 mW/g



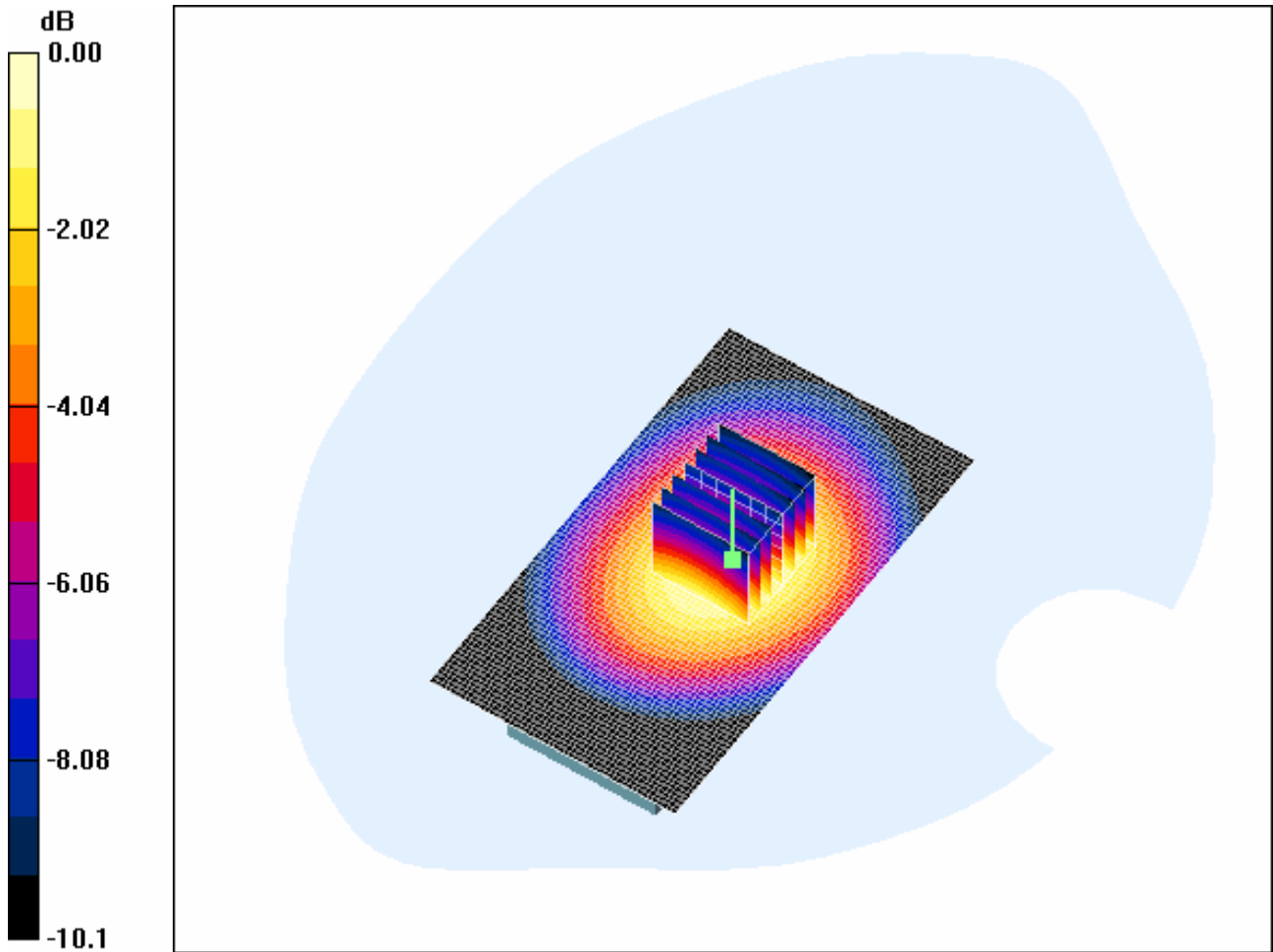

0 dB = 0.426mW/g

#### 4.15 FCC-OET65-Body-Worn-GSM850-High

Date/Time: 2005-9-21 16:31:51 Date/Time: 2005-9-21 16:37:24

Test Laboratory: SGS-GSM

#### FCC-OET65-Body-Worn-GSM850-High

DUT: GSM50084-Body; Type: Body; Serial: 20050921

Communication System: GSM850-GSM Mode; Frequency: 848.8 MHz; Duty Cycle: 1:8.3

Medium: HSL850-Body Medium parameters used:  $f = 848.8$  MHz;  $\sigma = 1.01$  mho/m;  $\epsilon_r = 52.5$ ;

$\rho = 1000 \text{ kg/m}^3$

Phantom section: Flat Section

Measurement Standard: DASY4 (High Precision Assessment)

DASY4 Configuration:

- Probe: ET3DV6 - SN1774; ConvF(6.65, 6.65, 6.65); Calibrated: 2004-10-26
- Sensor-Surface: 4mm (Mechanical Surface Detection)
- Electronics: DAE4 Sn611;
- Phantom: SAM 12; Type: SAM V4.0; Serial: TP-1283
- Measurement SW: DASY4, V4.5 Build 19; Postprocessing SW: SEMCAD, V1.8 Build 146

**Body Worn - High/Area Scan (51x91x1):** Measurement grid: dx=15mm, dy=15mm

Maximum value of SAR (interpolated) = 0.285 mW/g

**Body Worn - High/Zoom Scan (7x7x7) (7x7x7)/Cube 0:** Measurement grid:

dx=5mm, dy=5mm, dz=5mm

Reference Value = 13.3 V/m; Power Drift = 0.00 dB

Peak SAR (extrapolated) = 0.356 W/kg

**SAR(1 g) = 0.265 mW/g; SAR(10 g) = 0.183 mW/g**

Maximum value of SAR (measured) = 0.283 mW/g

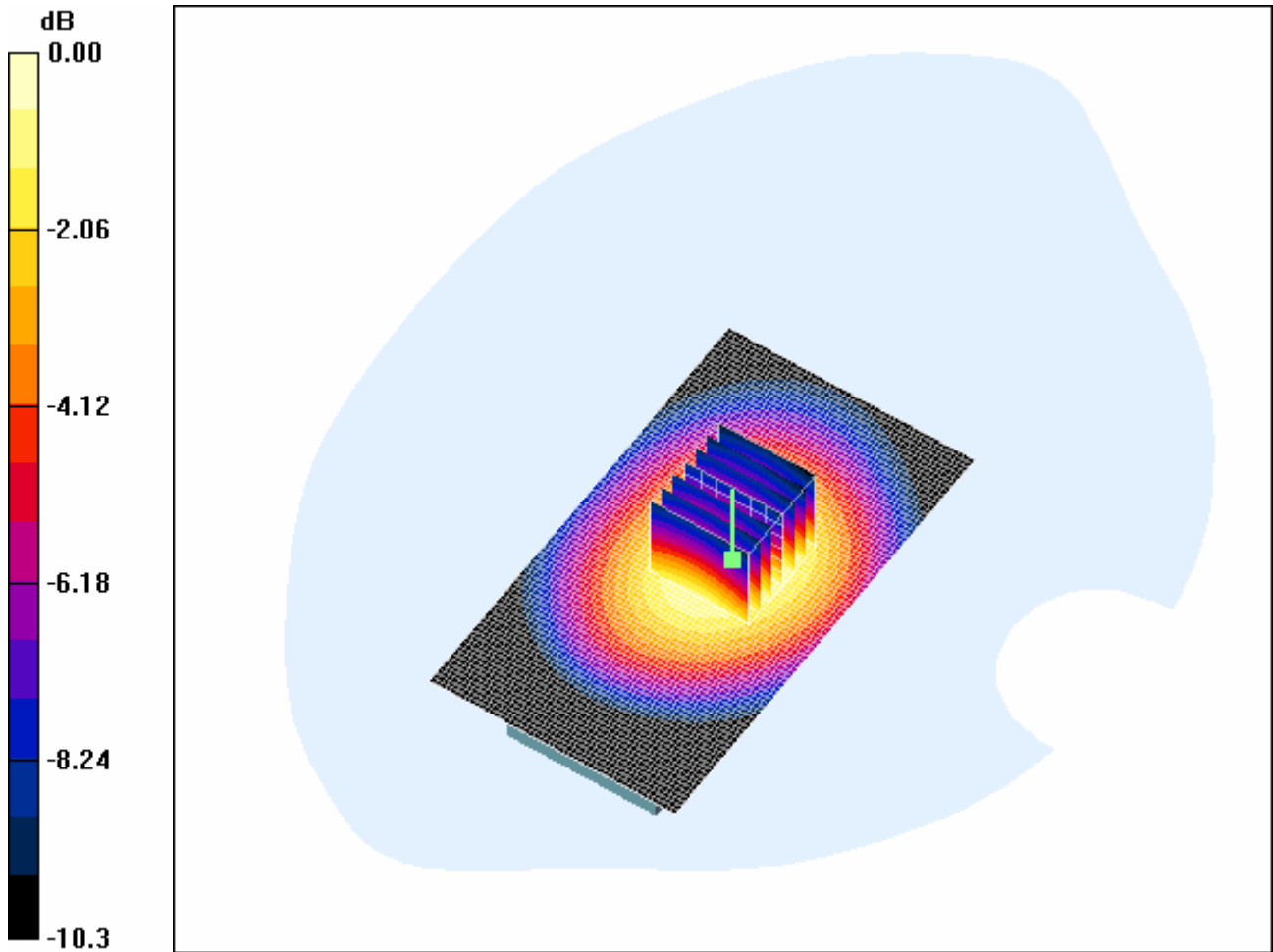

0 dB = 0.283mW/g

#### **4.16 FCC-OET65-LeftHandSide-Touch-GSM1900-Low**

Date/Time: 2005-9-20 13:40:30 Date/Time: 2005-9-20 13:50:52

Test Laboratory: SGS-GSM

#### **FCC-OET65-LeftHandSide-Touch-GSM1900-Low**

**DUT: GSM50084-Head; Type: Head; Serial: 20050914**

Communication System: DCS1900-GSM Mode; Frequency: 1850.2 MHz; Duty Cycle: 1:8.3  
Medium: HSL1900-Head Medium parameters used:  $f = 1850.2$  MHz;  $\sigma = 1.42$  mho/m;  $\epsilon_r =$

40.5;  $\rho = 1000 \text{ kg/m}^3$

Phantom section: Left Section

Measurement Standard: DAS4 (High Precision Assessment)

DAS4 Configuration:

- Probe: ET3DV6 - SN1774; ConvF(5.25, 5.25, 5.25); Calibrated: 2004-10-26
- Sensor-Surface: 4mm (Mechanical Surface Detection)
- Electronics: DAE4 Sn611;
- Phantom: SAM 12; Type: SAM V4.0; Serial: TP-1283
- Measurement SW: DAS4, V4.5 Build 19; Postprocessing SW: SEMCAD, V1.8 Build 146

**Touch position - Low/Area Scan (71x131x1):** Measurement grid: dx=15mm, dy=15mm

Maximum value of SAR (interpolated) = 0.703 mW/g

**Touch position - Low/Zoom Scan (7x7x7) (7x7x7)/Cube 0:** Measurement grid: dx=5mm, dy=5mm, dz=5mm

Reference Value = 6.12 V/m; Power Drift = -0.703 dB

Peak SAR (extrapolated) = 1.04 W/kg

**SAR(1 g) = 0.595 mW/g; SAR(10 g) = 0.320 mW/g**

Maximum value of SAR (measured) = 0.659 mW/g

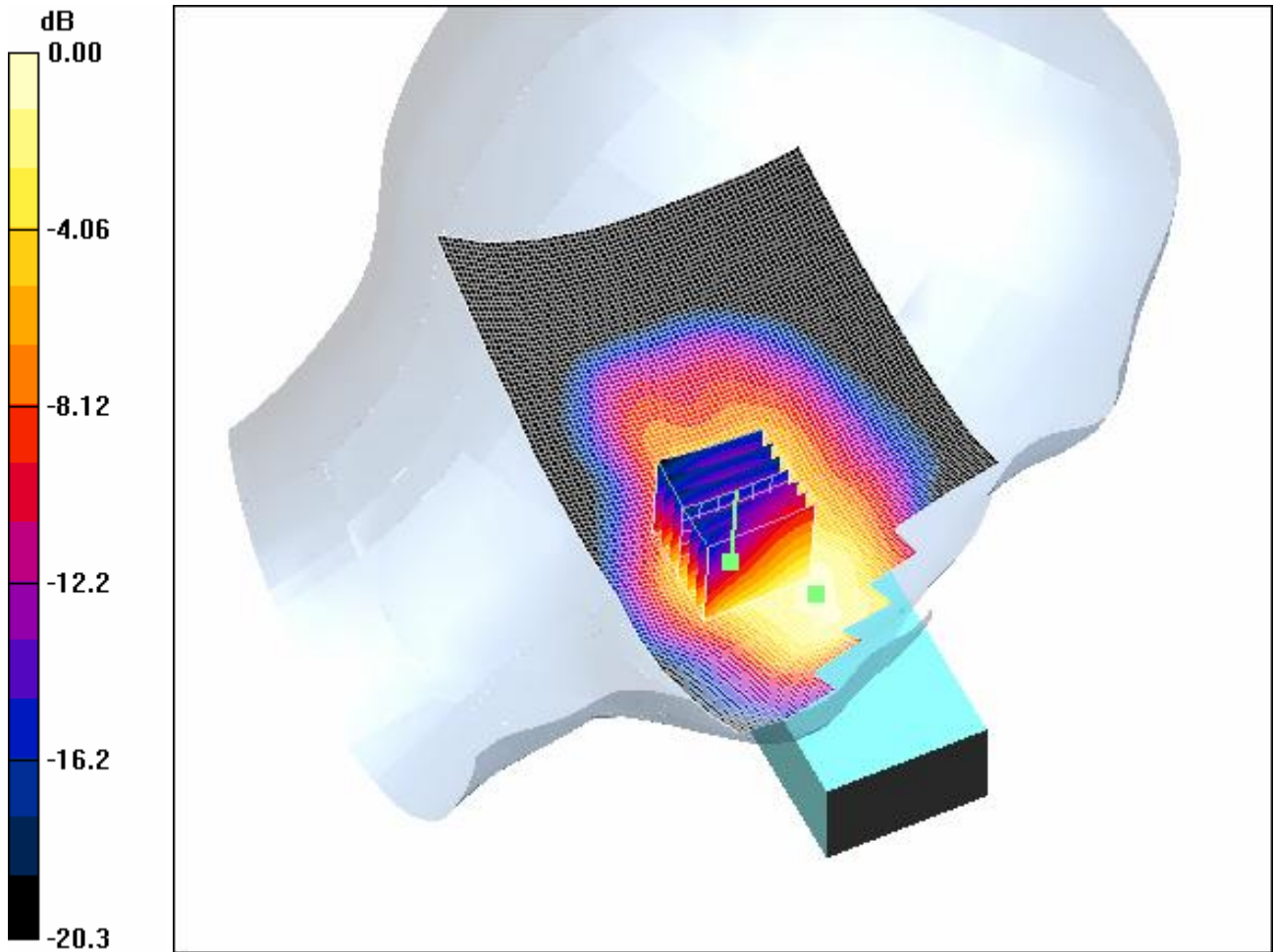

0 dB = 0.659mW/g

#### **4.17 FCC-OET65-LeftHandSide-Touch-GSM1900-Mid**

Date/Time: 2005-9-20 14:47:04 Date/Time: 2005-9-20 14:57:24

Test Laboratory: SGS-GSM

#### **FCC-OET65-LeftHandSide-Touch-GSM1900-Mid**

**DUT: GSM50084-Head; Type: Head; Serial: 20050914**

Communication System: DCS1900-GSM Mode; Frequency: 1880 MHz; Duty Cycle: 1:8.3  
Medium: HSL1900-Head Medium parameters used:  $f = 1880$  MHz;  $\sigma = 1.44$  mho/m;  $\epsilon_r =$

40.3;  $\rho = 1000 \text{ kg/m}^3$

Phantom section: Left Section

Measurement Standard: DASY4 (High Precision Assessment)

DASY4 Configuration:

- Probe: ET3DV6 - SN1774; ConvF(5.25, 5.25, 5.25); Calibrated: 2004-10-26
- Sensor-Surface: 4mm (Mechanical Surface Detection)
- Electronics: DAE4 Sn611;
- Phantom: SAM 12; Type: SAM V4.0; Serial: TP-1283
- Measurement SW: DASY4, V4.5 Build 19; Postprocessing SW: SEMCAD, V1.8 Build 146

**Touch position - Middle/Area Scan (71x131x1):** Measurement grid: dx=15mm, dy=15mm

Maximum value of SAR (interpolated) = 0.855 mW/g

**Touch position - Middle/Zoom Scan (7x7x7)/Cube 0:** Measurement grid: dx=5mm, dy=5mm, dz=5mm

Reference Value = 6.64 V/m; Power Drift = -0.196 dB

Peak SAR (extrapolated) = 1.22 W/kg

**SAR(1 g) = 0.727 mW/g; SAR(10 g) = 0.389 mW/g**

Maximum value of SAR (measured) = 0.766 mW/g

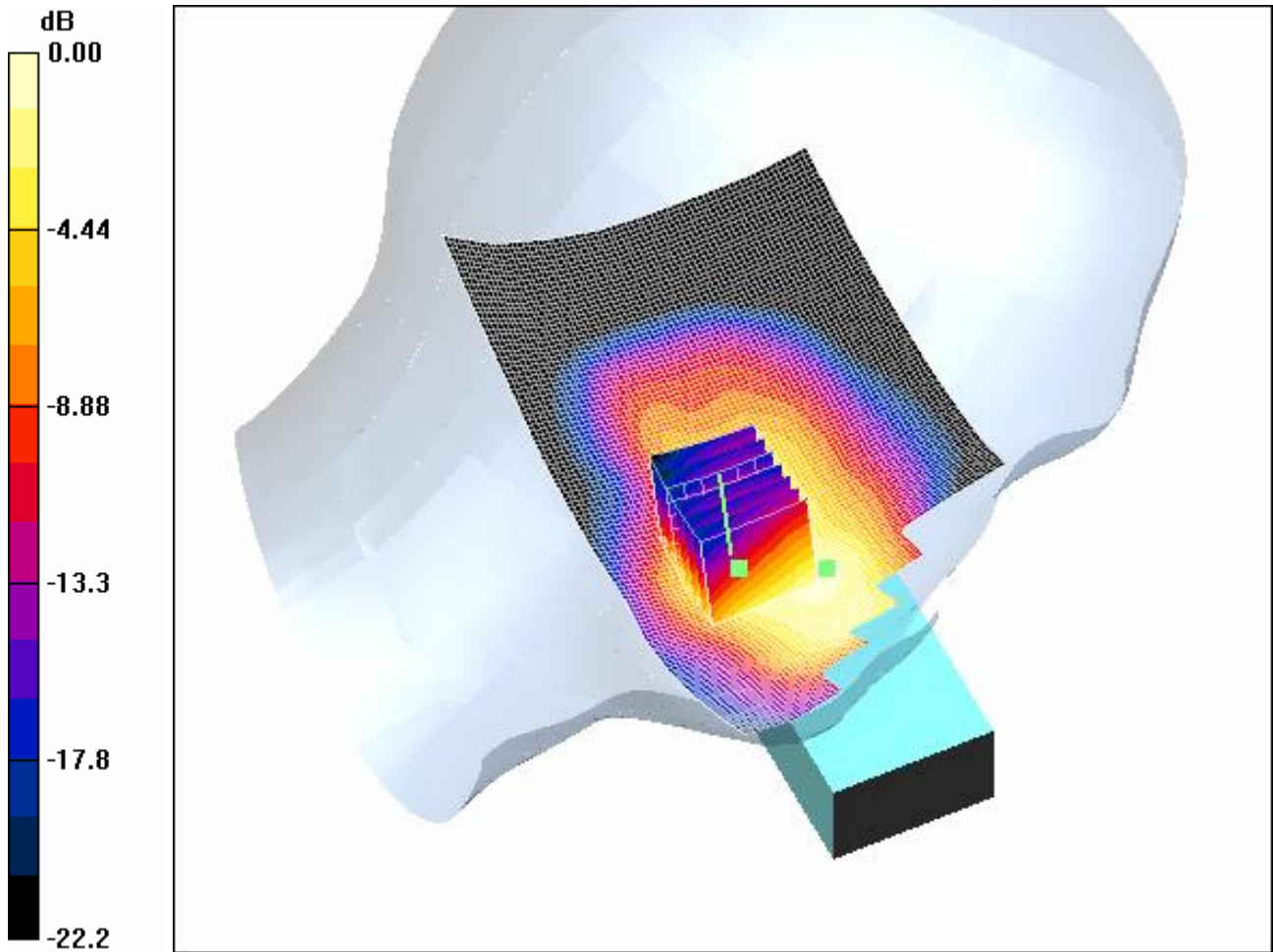

0 dB = 0.766mW/g

#### **4.18 FCC-OET65-LeftHandSide-Touch-GSM1900-High**

Date/Time: 2005-9-20 15:19:02 Date/Time: 2005-9-20 15:29:23

Test Laboratory: SGS-GSM

#### **FCC-OET65-LeftHandSide-Touch-GSM1900-High**

**DUT: GSM50084-Head; Type: Head; Serial: 20050914**

Communication System: DCS1900-GSM Mode; Frequency: 1909.8 MHz; Duty Cycle: 1:8.3  
Medium: HSL1900-Head Medium parameters used:  $f = 1909.8$  MHz;  $\sigma = 1.47$  mho/m;  $\epsilon_r =$

40;  $\rho = 1000 \text{ kg/m}^3$

Phantom section: Left Section

Measurement Standard: DAS4 (High Precision Assessment)

DAS4 Configuration:

- Probe: ET3DV6 - SN1774; ConvF(5.25, 5.25, 5.25); Calibrated: 2004-10-26
- Sensor-Surface: 4mm (Mechanical Surface Detection)
- Electronics: DAE4 Sn611;
- Phantom: SAM 12; Type: SAM V4.0; Serial: TP-1283
- Measurement SW: DAS4, V4.5 Build 19; Postprocessing SW: SEMCAD, V1.8 Build 146

**Touch position - High/Area Scan (71x131x1):** Measurement grid: dx=15mm, dy=15mm

Maximum value of SAR (interpolated) = 0.820 mW/g

**Touch position - High/Zoom Scan (7x7x7) (7x7x7)/Cube 0:** Measurement grid: dx=5mm, dy=5mm, dz=5mm

Reference Value = 6.80 V/m; Power Drift = -0.033 dB

Peak SAR (extrapolated) = 1.16 W/kg

**SAR(1 g) = 0.710 mW/g; SAR(10 g) = 0.382 mW/g**

Maximum value of SAR (measured) = 0.735 mW/g



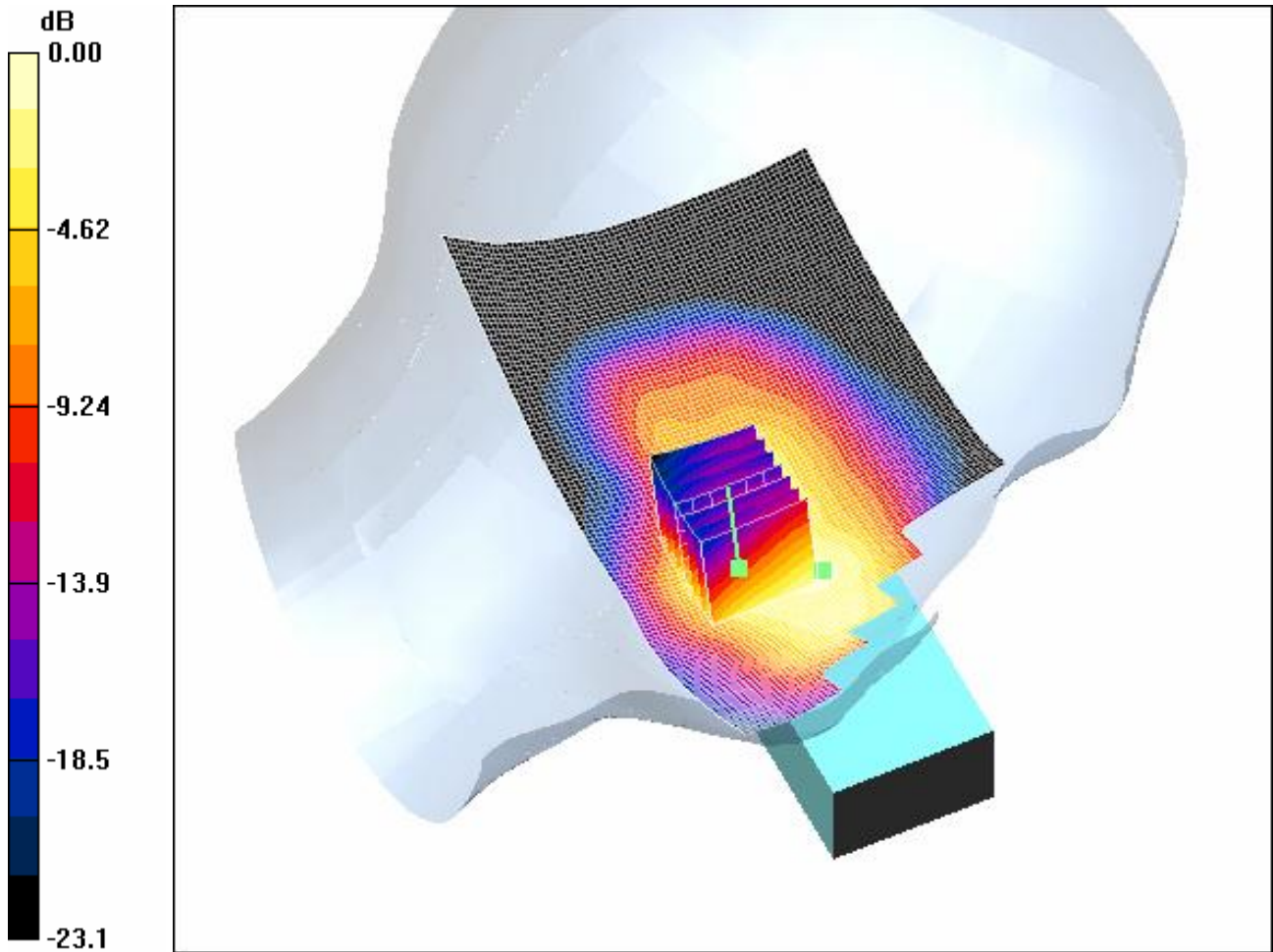

0 dB = 0.735mW/g

#### **4.19 FCC-OET65-LeftHandSide-Tilt-GSM1900-Low**

Date/Time: 2005-9-20 16:19:19 Date/Time: 2005-9-20 16:29:45

Test Laboratory: SGS-GSM

#### **FCC-OET65-LeftHandSide-Tilt-GSM1900-Low**

**DUT: GSM50084-Head; Type: Head; Serial: 20050914**

Communication System: DCS1900-GSM Mode; Frequency: 1850.2 MHz; Duty Cycle: 1:8.3  
Medium: HSL1900-Head Medium parameters used:  $f = 1850.2$  MHz;  $\sigma = 1.42$  mho/m;  $\epsilon_r =$

40.5;  $\rho = 1000 \text{ kg/m}^3$

Phantom section: Left Section

Measurement Standard: DAS4 (High Precision Assessment)

DAS4 Configuration:

- Probe: ET3DV6 - SN1774; ConvF(5.25, 5.25, 5.25); Calibrated: 2004-10-26
- Sensor-Surface: 4mm (Mechanical Surface Detection)
- Electronics: DAE4 Sn611;
- Phantom: SAM 12; Type: SAM V4.0; Serial: TP-1283
- Measurement SW: DAS4, V4.5 Build 19; Postprocessing SW: SEMCAD, V1.8 Build 146

**Tilt position - Low/Area Scan (71x131x1):** Measurement grid: dx=15mm, dy=15mm  
Maximum value of SAR (interpolated) = 0.133 mW/g

**Tilt position - Low/Zoom Scan (7x7x7) (7x7x7)/Cube 0:** Measurement grid:  
dx=5mm, dy=5mm, dz=5mm

Reference Value = 8.33 V/m; Power Drift = -0.439 dB

Peak SAR (extrapolated) = 0.158 W/kg

**SAR(1 g) = 0.109 mW/g; SAR(10 g) = 0.072 mW/g**

Maximum value of SAR (measured) = 0.121 mW/g

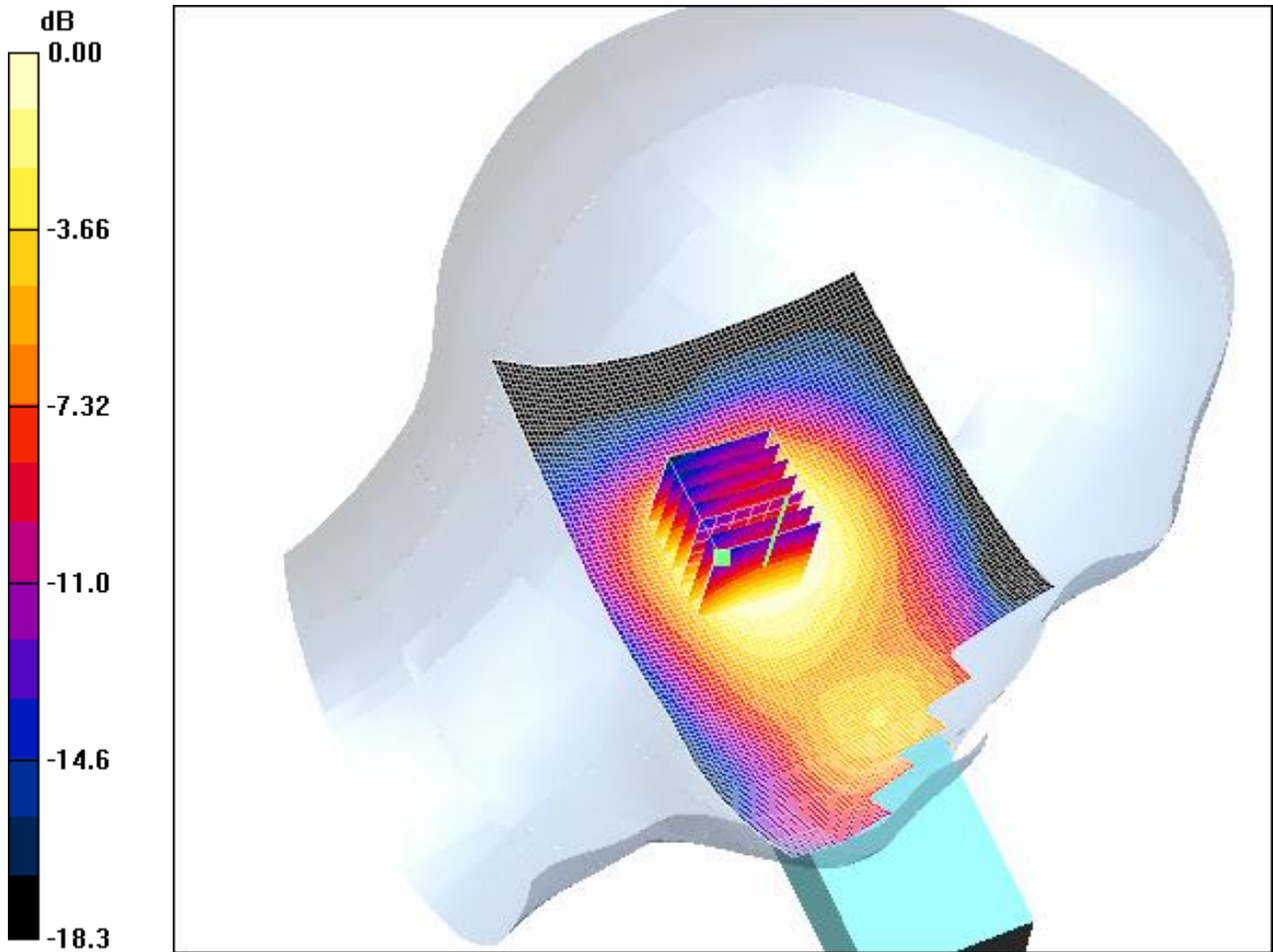

0 dB = 0.121mW/g

#### **4.20 FCC-OET65-LeftHandSide-Tilt-GSM1900-Mid**

Date/Time: 2005-9-20 16:58:44 Date/Time: 2005-9-20 17:09:09

Test Laboratory: SGS-GSM

#### **FCC-OET65-LeftHandSide-Tilt-GSM1900-Mid**

**DUT: GSM50084-Head; Type: Head; Serial: 20050914**

Communication System: DCS1900-GSM Mode; Frequency: 1880 MHz; Duty Cycle: 1:8.3  
Medium: HSL1900-Head Medium parameters used:  $f = 1880$  MHz;  $\sigma = 1.44$  mho/m;  $\epsilon_r =$

40.3;  $\rho = 1000 \text{ kg/m}^3$

Phantom section: Left Section

Measurement Standard: DAS4 (High Precision Assessment)

DAS4 Configuration:

- Probe: ET3DV6 - SN1774; ConvF(5.25, 5.25, 5.25); Calibrated: 2004-10-26
- Sensor-Surface: 4mm (Mechanical Surface Detection)
- Electronics: DAE4 Sn611;
- Phantom: SAM 12; Type: SAM V4.0; Serial: TP-1283
- Measurement SW: DAS4, V4.5 Build 19; Postprocessing SW: SEMCAD, V1.8 Build 146

**Tilt position - Middle/Area Scan (71x131x1):** Measurement grid: dx=15mm, dy=15mm

Maximum value of SAR (interpolated) = 0.163 mW/g

**Tilt position - Middle/Zoom Scan (7x7x7)/Cube 0:** Measurement grid: dx=5mm, dy=5mm, dz=5mm

Reference Value = 9.17 V/m; Power Drift = 0.022 dB

Peak SAR (extrapolated) = 0.200 W/kg

**SAR(1 g) = 0.142 mW/g; SAR(10 g) = 0.093 mW/g**

Maximum value of SAR (measured) = 0.151 mW/g

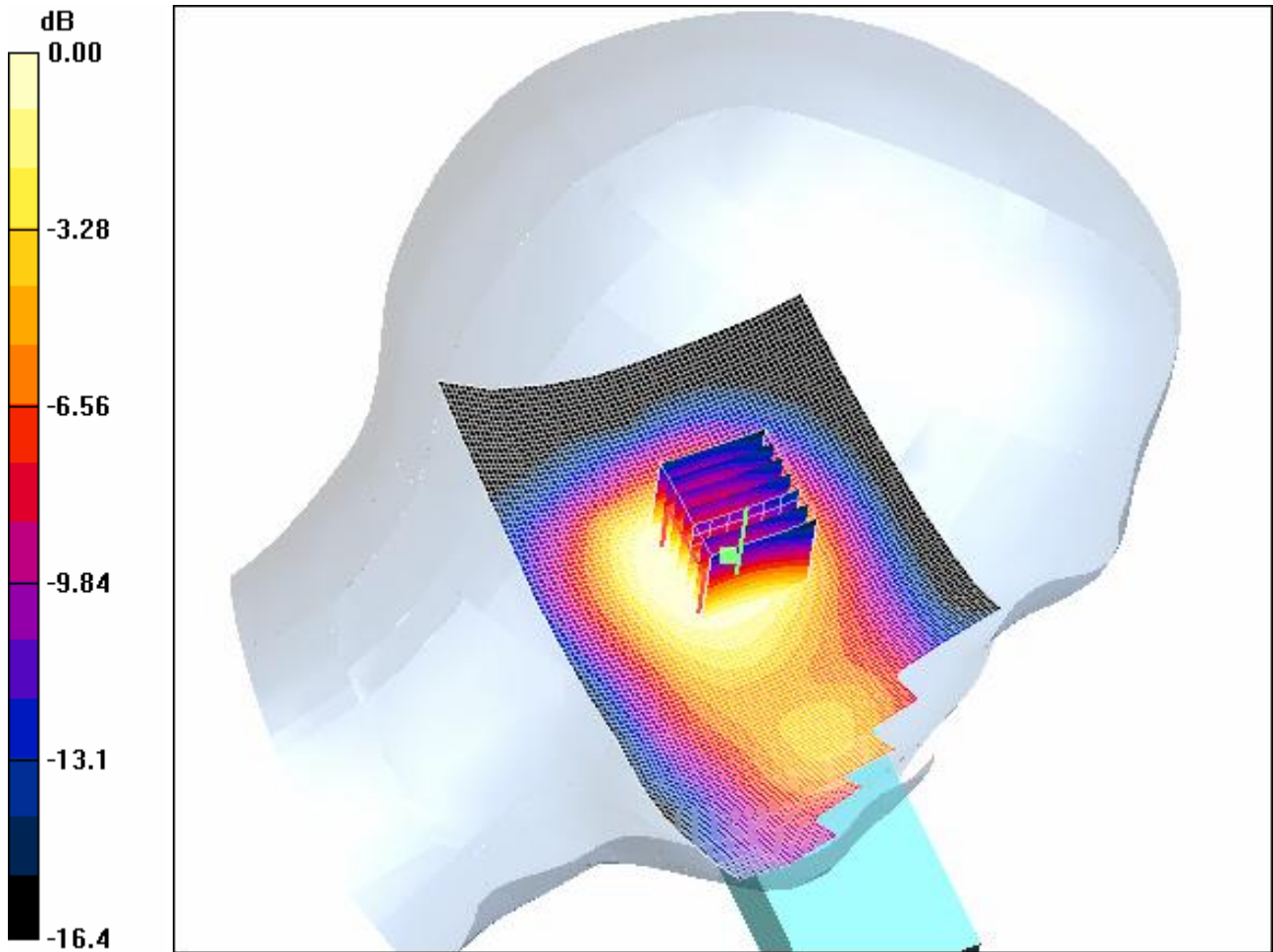

0 dB = 0.151mW/g

#### 4.21 FCC-OET65-LeftHandSide-Tilt-GSM1900-High

Date/Time: 2005-9-20 17:34:19 Date/Time: 2005-9-20 17:44:44

Test Laboratory: SGS-GSM

#### FCC-OET65-LeftHandSide-Tilt-GSM1900-High

DUT: GSM50084-Head; Type: Head; Serial: 20050914

Communication System: DCS1900-GSM Mode; Frequency: 1909.8 MHz; Duty Cycle: 1:8.3  
Medium: HSL1900-Head Medium parameters used:  $f = 1909.8$  MHz;  $\sigma = 1.47$  mho/m;  $\epsilon_r =$

40;  $\rho = 1000 \text{ kg/m}^3$

Phantom section: Left Section

Measurement Standard: DAS4 (High Precision Assessment)

DAS4 Configuration:

- Probe: ET3DV6 - SN1774; ConvF(5.25, 5.25, 5.25); Calibrated: 2004-10-26
- Sensor-Surface: 4mm (Mechanical Surface Detection)
- Electronics: DAE4 Sn611;
- Phantom: SAM 12; Type: SAM V4.0; Serial: TP-1283
- Measurement SW: DAS4, V4.5 Build 19; Postprocessing SW: SEMCAD, V1.8 Build 146

**Tilt position - High/Area Scan (71x131x1):** Measurement grid: dx=15mm, dy=15mm  
Maximum value of SAR (interpolated) = 0.161 mW/g

**Tilt position - High/Zoom Scan (7x7x7) (7x7x7)/Cube 0:** Measurement grid:  
dx=5mm, dy=5mm, dz=5mm

Reference Value = 9.18 V/m; Power Drift = 0.013 dB

Peak SAR (extrapolated) = 0.205 W/kg

**SAR(1 g) = 0.142 mW/g; SAR(10 g) = 0.091 mW/g**

Maximum value of SAR (measured) = 0.152 mW/g

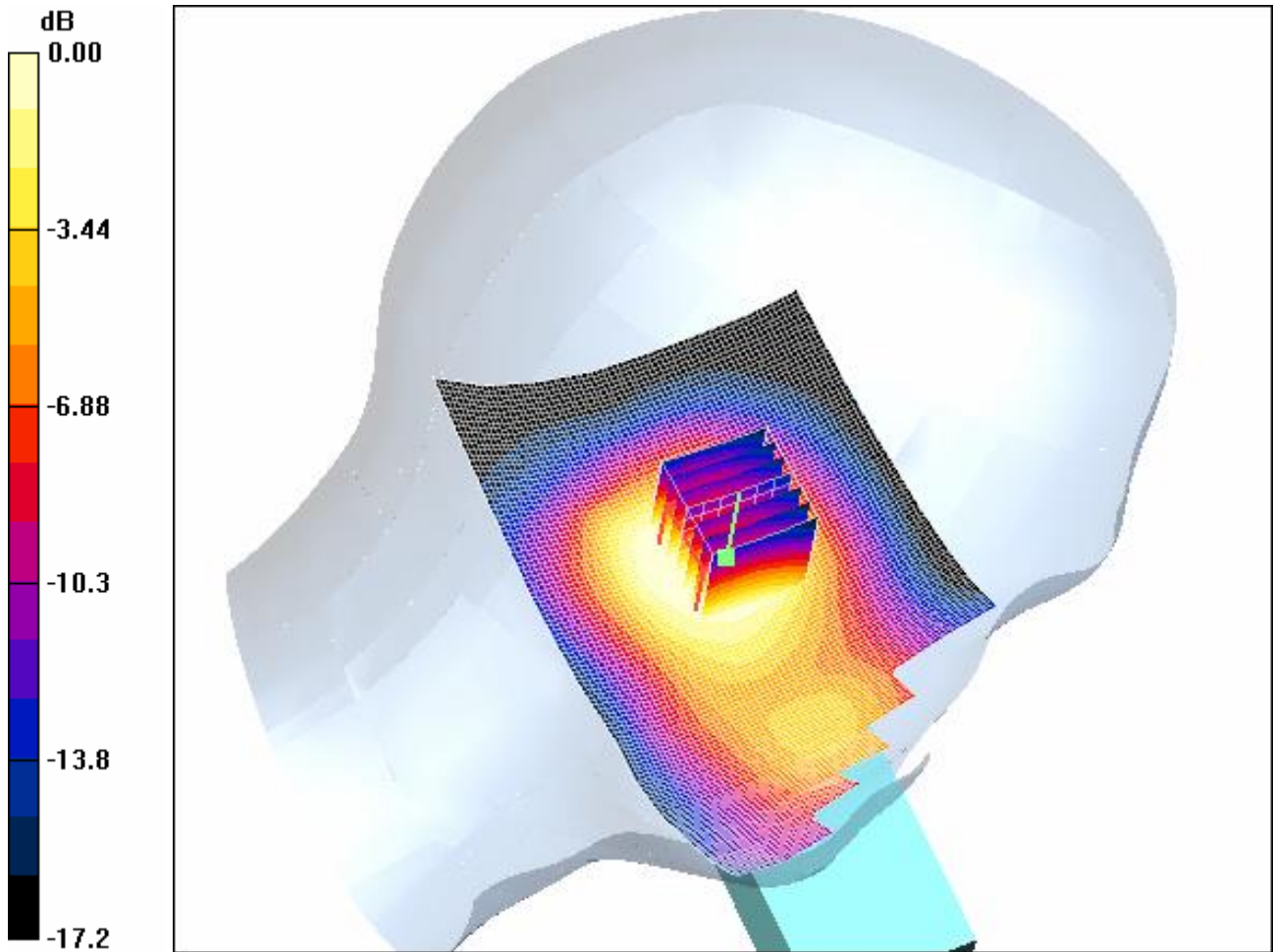

0 dB = 0.152mW/g

#### **4.22 FCC-OET65-RightHandSide-Touch-GSM1900-Low**

Date/Time: 2005-9-20 9:15:05 Date/Time: 2005-9-20 9:25:48

Test Laboratory: SGS-GSM

#### **FCC-OET65-RightHandSide-Touch-GSM1900-Low**

**DUT: GSM50084-Head; Type: Head; Serial: 20050914**

Communication System: DCS1900-GSM Mode; Frequency: 1850.2 MHz; Duty Cycle: 1:8.3  
Medium: HSL1900-Head Medium parameters used:  $f = 1850.2$  MHz;  $\sigma = 1.42$  mho/m;  $\epsilon_r =$

40.5;  $\rho = 1000 \text{ kg/m}^3$

Phantom section: Right Section

Measurement Standard: DAS4 (High Precision Assessment)

DAS4 Configuration:

- Probe: ET3DV6 - SN1774; ConvF(5.25, 5.25, 5.25); Calibrated: 2004-10-26
- Sensor-Surface: 4mm (Mechanical Surface Detection)
- Electronics: DAE4 Sn611;
- Phantom: SAM 12; Type: SAM V4.0; Serial: TP-1283
- Measurement SW: DAS4, V4.5 Build 19; Postprocessing SW: SEMCAD, V1.8 Build 146

**Touch position - Low/Area Scan (71x131x1):** Measurement grid: dx=15mm, dy=15mm

Maximum value of SAR (interpolated) = 0.825 mW/g

**Touch position - Low/Zoom Scan (7x7x7) (7x7x7)/Cube 0:** Measurement grid: dx=5mm, dy=5mm, dz=5mm

Reference Value = 5.87 V/m; Power Drift = 0.135 dB

Peak SAR (extrapolated) = 1.19 W/kg

**SAR(1 g) = 0.762 mW/g; SAR(10 g) = 0.441 mW/g**

Maximum value of SAR (measured) = 0.868 mW/g



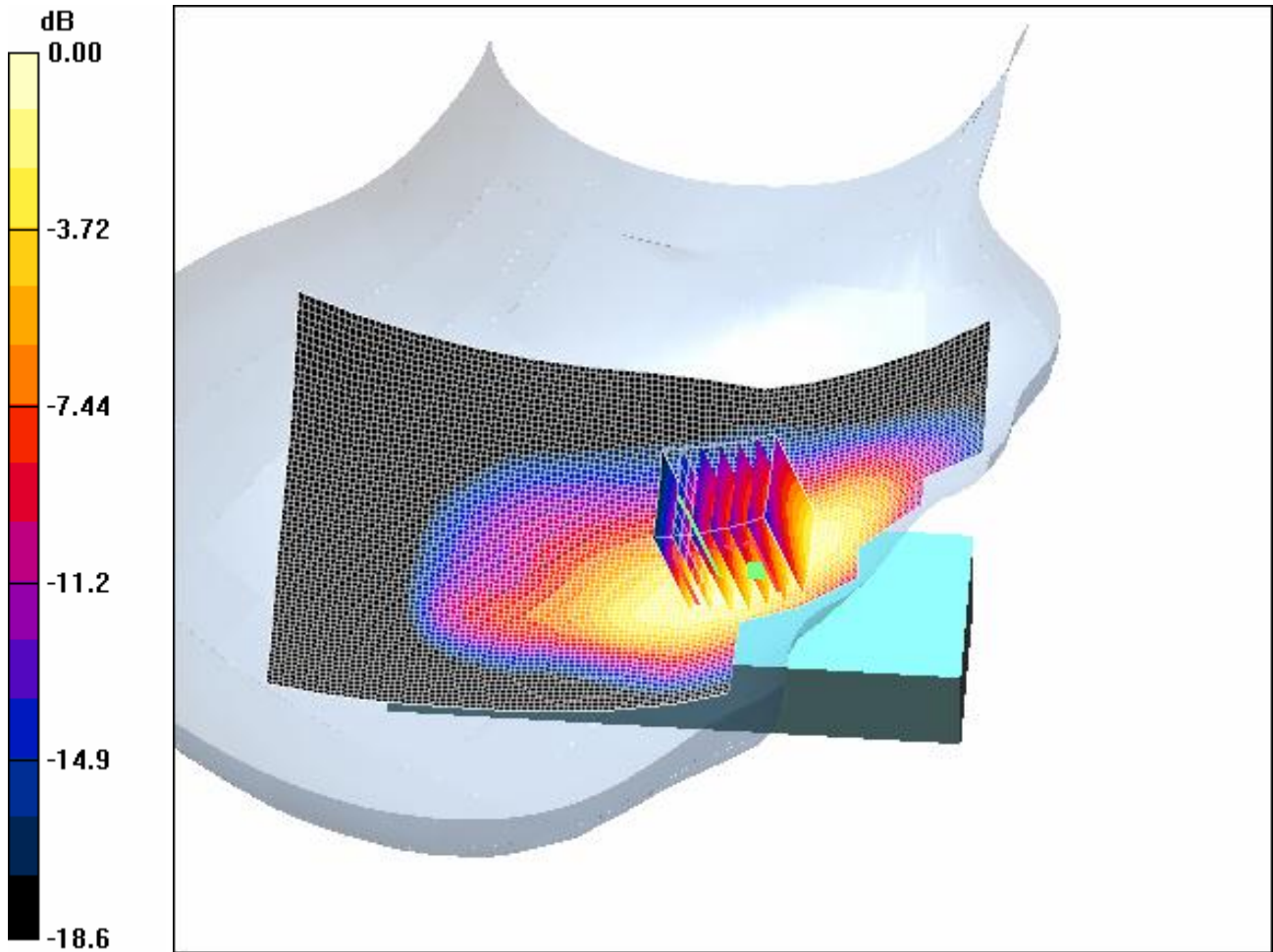

0 dB = 0.868mW/g

#### **4.23 FCC-OET65-RightHandSide-Touch-GSM1900-Mid**

Date/Time: 2005-9-20 9:47:01 Date/Time: 2005-9-20 9:57:55

Test Laboratory: SGS-GSM

#### **FCC-OET65-RightHandSide-Touch-GSM1900-Mid**

**DUT: GSM50084-Head; Type: Head; Serial: 20050914**

Communication System: DCS1900-GSM Mode; Frequency: 1880 MHz; Duty Cycle: 1:8.3  
Medium: HSL1900-Head Medium parameters used:  $f = 1880$  MHz;  $\sigma = 1.44$  mho/m;  $\epsilon_r =$

40.3;  $\rho = 1000 \text{ kg/m}^3$

Phantom section: Right Section

Measurement Standard: DASY4 (High Precision Assessment)

DASY4 Configuration:

- Probe: ET3DV6 - SN1774; ConvF(5.25, 5.25, 5.25); Calibrated: 2004-10-26
- Sensor-Surface: 4mm (Mechanical Surface Detection)
- Electronics: DAE4 Sn611;
- Phantom: SAM 12; Type: SAM V4.0; Serial: TP-1283
- Measurement SW: DASY4, V4.5 Build 19; Postprocessing SW: SEMCAD, V1.8 Build 146

**Touch position - Middle/Area Scan (71x131x1):** Measurement grid: dx=15mm, dy=15mm

Maximum value of SAR (interpolated) = 0.878 mW/g

**Touch position - Middle/Zoom Scan (7x7x7)/Cube 0:** Measurement grid: dx=5mm, dy=5mm, dz=5mm

Reference Value = 6.55 V/m; Power Drift = -0.088 dB

Peak SAR (extrapolated) = 1.37 W/kg

**SAR(1 g) = 0.849 mW/g; SAR(10 g) = 0.482 mW/g**

Maximum value of SAR (measured) = 0.964 mW/g

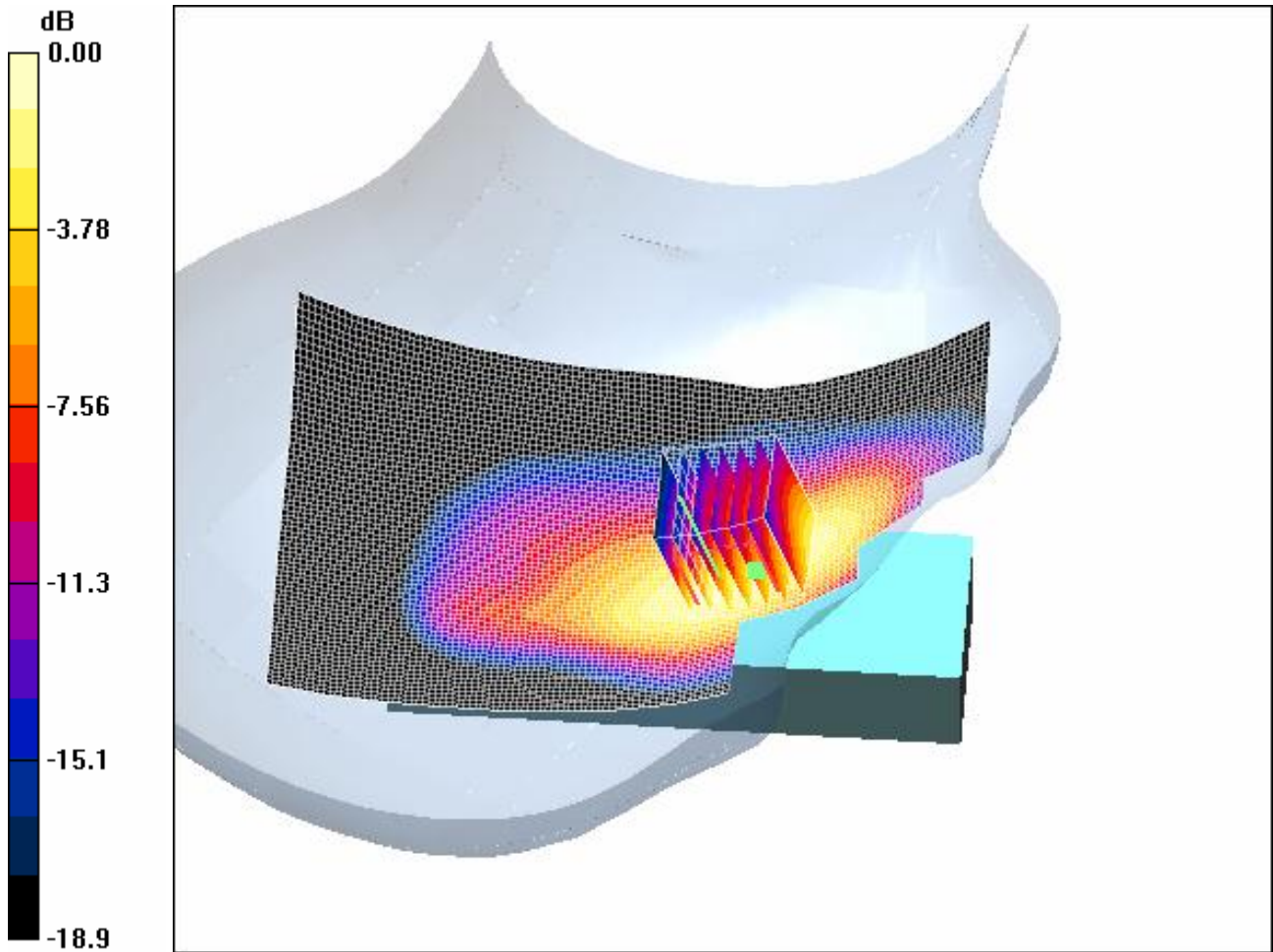

0 dB = 0.964mW/g

#### **4.24 FCC-OET65-RightHandSide-Touch-GSM1900-High**

Date/Time: 2005-9-20 10:26:32 Date/Time: 2005-9-20 10:39:58

Test Laboratory: SGS-GSM

#### **FCC-OET65-RightHandSide-Touch-GSM1900-High**

**DUT: GSM50084-Head; Type: Head; Serial: 20050914**

Communication System: DCS1900-GSM Mode; Frequency: 1909.8 MHz; Duty Cycle: 1:8.3  
Medium: HSL1900-Head Medium parameters used:  $f = 1909.8$  MHz;  $\sigma = 1.47$  mho/m;  $\epsilon_r =$

40;  $\rho = 1000 \text{ kg/m}^3$

Phantom section: Right Section

Measurement Standard: DAS4 (High Precision Assessment)

DAS4 Configuration:

- Probe: ET3DV6 - SN1774; ConvF(5.25, 5.25, 5.25); Calibrated: 2004-10-26
- Sensor-Surface: 4mm (Mechanical Surface Detection)
- Electronics: DAE4 Sn611;
- Phantom: SAM 12; Type: SAM V4.0; Serial: TP-1283
- Measurement SW: DAS4, V4.5 Build 19; Postprocessing SW: SEMCAD, V1.8 Build 146

**Touch position - High/Area Scan (71x131x1):** Measurement grid: dx=15mm, dy=15mm

Maximum value of SAR (interpolated) = 0.796 mW/g

**Touch position - High/Zoom Scan (7x7x7) (7x7x7)/Cube 0:** Measurement grid: dx=5mm, dy=5mm, dz=5mm

Reference Value = 6.79 V/m; Power Drift = -0.169 dB

Peak SAR (extrapolated) = 1.26 W/kg

**SAR(1 g) = 0.776 mW/g; SAR(10 g) = 0.435 mW/g**

Maximum value of SAR (measured) = 0.878 mW/g

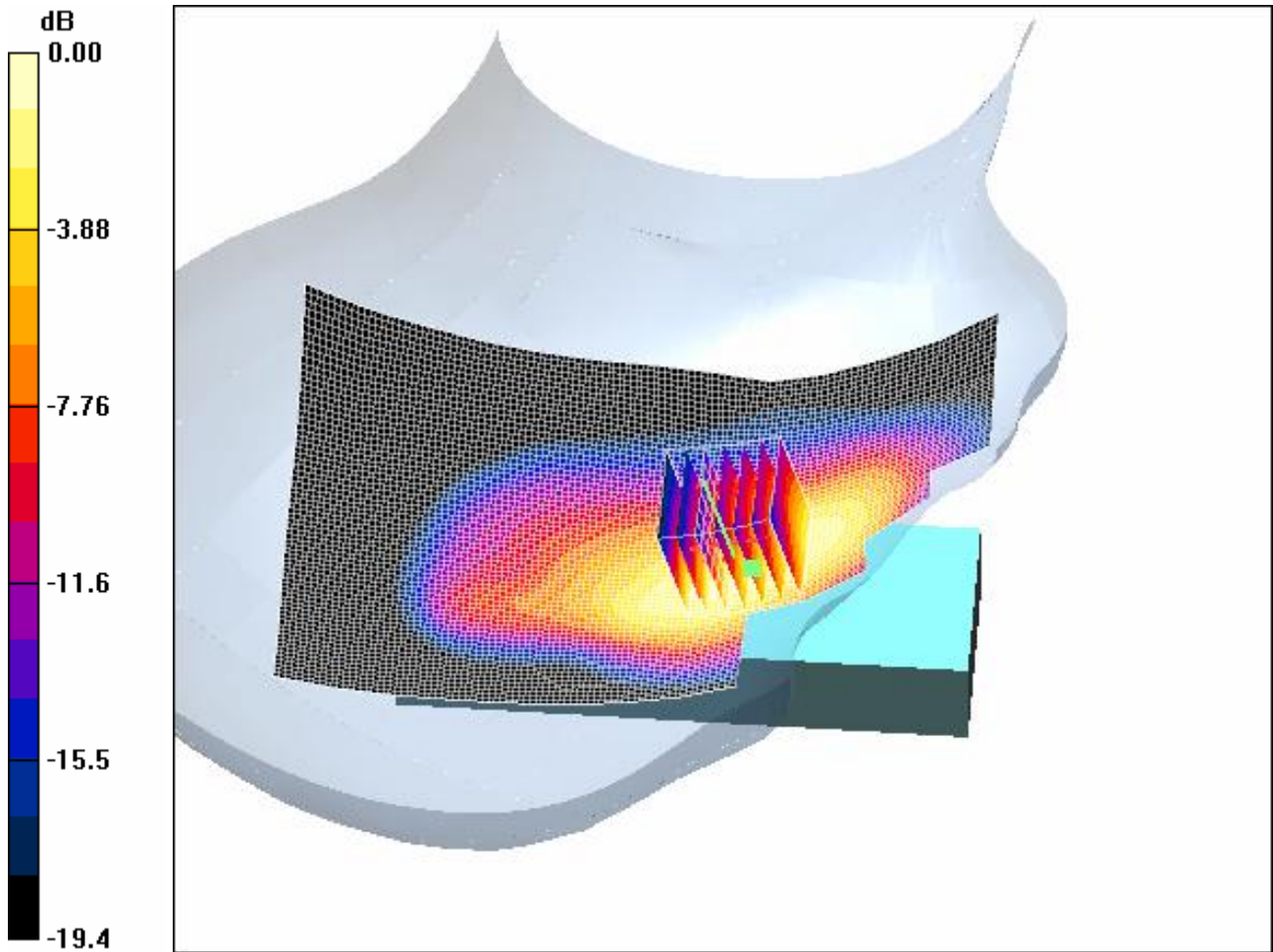

0 dB = 0.878mW/g

#### **4.25 FCC-OET65-RightHandSide-Tilt-GSM1900-Low**

Date/Time: 2005-9-20 11:20:11 Date/Time: 2005-9-20 11:31:07

Test Laboratory: SGS-GSM

#### **FCC-OET65-RightHandSide-Tilt-GSM1900-Low**

**DUT: GSM50084-Head; Type: Head; Serial: 20050914**

Communication System: DCS1900-GSM Mode; Frequency: 1850.2 MHz; Duty Cycle: 1:8.3  
Medium: HSL1900-Head Medium parameters used:  $f = 1850.2$  MHz;  $\sigma = 1.42$  mho/m;  $\epsilon_r =$

40.5;  $\rho = 1000 \text{ kg/m}^3$

Phantom section: Right Section

Measurement Standard: DAS4 (High Precision Assessment)

DAS4 Configuration:

- Probe: ET3DV6 - SN1774; ConvF(5.25, 5.25, 5.25); Calibrated: 2004-10-26
- Sensor-Surface: 4mm (Mechanical Surface Detection)
- Electronics: DAE4 Sn611;
- Phantom: SAM 12; Type: SAM V4.0; Serial: TP-1283
- Measurement SW: DAS4, V4.5 Build 19; Postprocessing SW: SEMCAD, V1.8 Build 146

**Tilt position - Low/Area Scan (71x131x1):** Measurement grid: dx=15mm, dy=15mm  
Maximum value of SAR (interpolated) = 0.148 mW/g

**Tilt position - Low/Zoom Scan (7x7x7) (7x7x7)/Cube 0:** Measurement grid:  
dx=5mm, dy=5mm, dz=5mm

Reference Value = 8.82 V/m; Power Drift = -0.061 dB

Peak SAR (extrapolated) = 0.182 W/kg

**SAR(1 g) = 0.127 mW/g; SAR(10 g) = 0.081 mW/g**

Maximum value of SAR (measured) = 0.138 mW/g

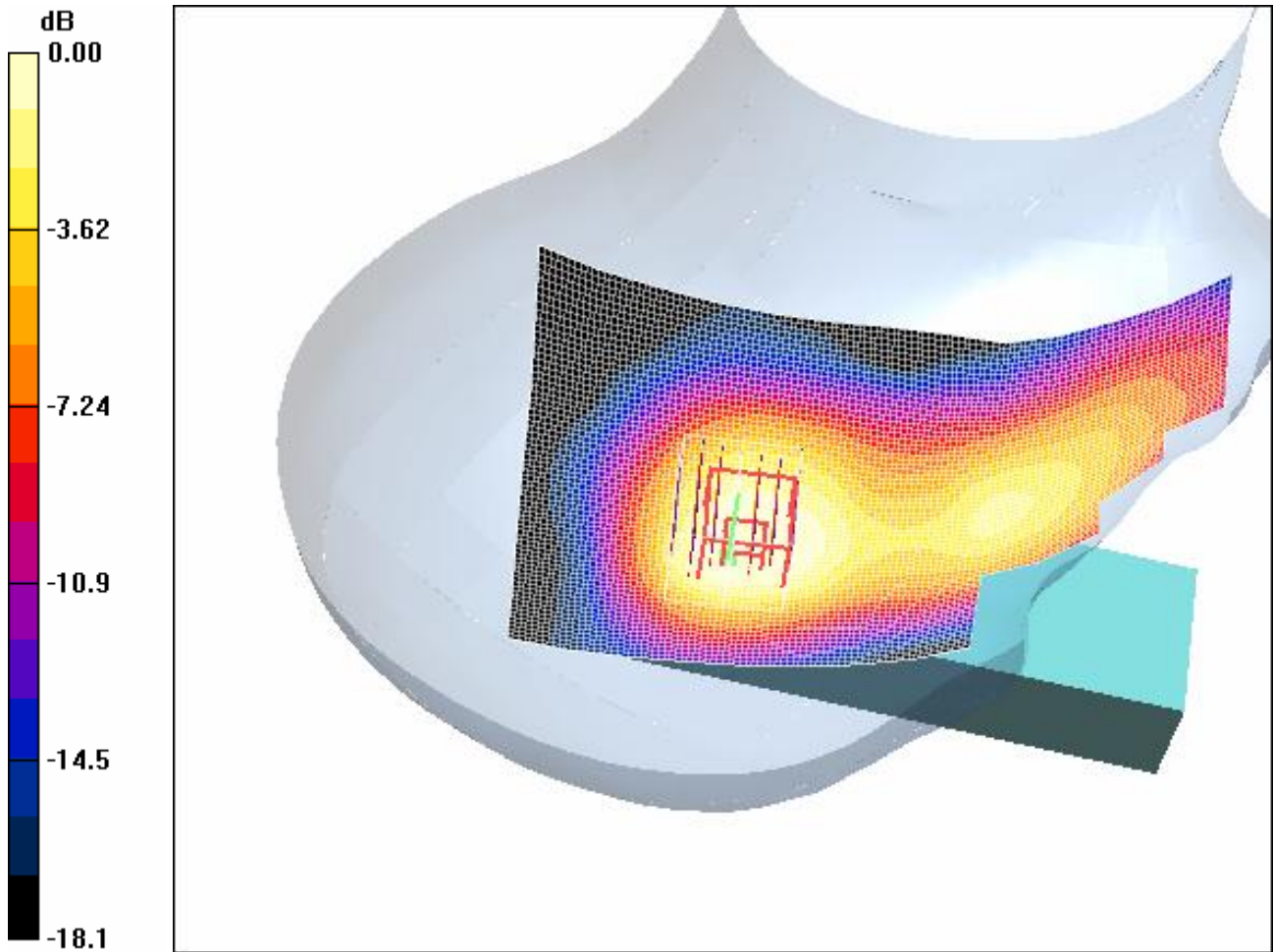

0 dB = 0.138mW/g

#### **4.26 FCC-OET65-RightHandSide-Tilt-GSM1900-Mid**

Date/Time: 2005-9-20 12:08:14 Date/Time: 2005-9-20 12:19:11

Test Laboratory: SGS-GSM

#### **FCC-OET65-RightHandSide-Tilt-GSM1900-Mid**

**DUT: GSM50084-Head; Type: Head; Serial: 20050914**

Communication System: DCS1900-GSM Mode; Frequency: 1880 MHz; Duty Cycle: 1:8.3  
Medium: HSL1900-Head Medium parameters used:  $f = 1880$  MHz;  $\sigma = 1.44$  mho/m;  $\epsilon_r =$

40.3;  $\rho = 1000 \text{ kg/m}^3$

Phantom section: Right Section

Measurement Standard: DASY4 (High Precision Assessment)

DASY4 Configuration:

- Probe: ET3DV6 - SN1774; ConvF(5.25, 5.25, 5.25); Calibrated: 2004-10-26
- Sensor-Surface: 4mm (Mechanical Surface Detection)
- Electronics: DAE4 Sn611;
- Phantom: SAM 12; Type: SAM V4.0; Serial: TP-1283
- Measurement SW: DASY4, V4.5 Build 19; Postprocessing SW: SEMCAD, V1.8 Build 146

**Tilt position - Middle/Area Scan (71x131x1):** Measurement grid: dx=15mm,  
dy=15mm

Maximum value of SAR (interpolated) = 0.165 mW/g

**Tilt position - Middle/Zoom Scan (7x7x7)/Cube 0:** Measurement grid: dx=5mm,  
dy=5mm, dz=5mm

Reference Value = 9.32 V/m; Power Drift = -0.045 dB

Peak SAR (extrapolated) = 0.207 W/kg

**SAR(1 g) = 0.142 mW/g; SAR(10 g) = 0.090 mW/g**

Maximum value of SAR (measured) = 0.152 mW/g



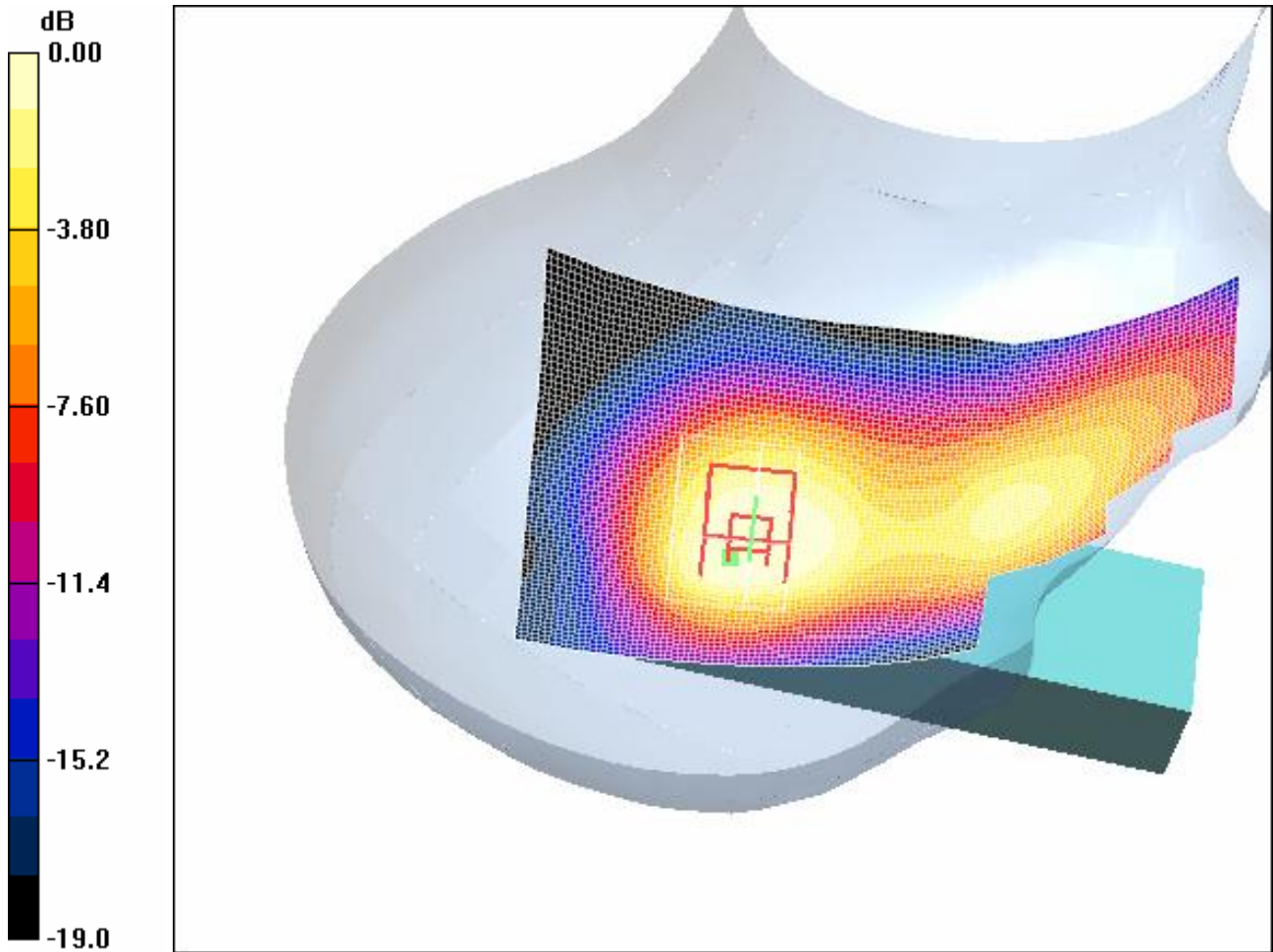

0 dB = 0.152mW/g

#### **4.27 FCC-OET65-RightHandSide-Tilt-GSM1900-High**

Date/Time: 2005-9-20 12:43:07 Date/Time: 2005-9-20 12:54:09

Test Laboratory: SGS-GSM

#### **FCC-OET65-RightHandSide-Tilt-GSM1900-High**

**DUT: GSM50084-Head; Type: Head; Serial: 20050914**

Communication System: DCS1900-GSM Mode; Frequency: 1909.8 MHz; Duty Cycle: 1:8.3  
Medium: HSL1900-Head Medium parameters used:  $f = 1909.8$  MHz;  $\sigma = 1.47$  mho/m;  $\epsilon_r =$

40;  $\rho = 1000 \text{ kg/m}^3$

Phantom section: Right Section

Measurement Standard: DAS4 (High Precision Assessment)

DAS4 Configuration:

- Probe: ET3DV6 - SN1774; ConvF(5.25, 5.25, 5.25); Calibrated: 2004-10-26
- Sensor-Surface: 4mm (Mechanical Surface Detection)
- Electronics: DAE4 Sn611;
- Phantom: SAM 12; Type: SAM V4.0; Serial: TP-1283
- Measurement SW: DAS4, V4.5 Build 19; Postprocessing SW: SEMCAD, V1.8 Build 146

**Tilt position - High/Area Scan (71x131x1):** Measurement grid: dx=15mm, dy=15mm  
Maximum value of SAR (interpolated) = 0.159 mW/g

**Tilt position - High/Zoom Scan (7x7x7) (7x7x7)/Cube 0:** Measurement grid:  
dx=5mm, dy=5mm, dz=5mm

Reference Value = 9.41 V/m; Power Drift = -0.070 dB

Peak SAR (extrapolated) = 0.202 W/kg

**SAR(1 g) = 0.139 mW/g; SAR(10 g) = 0.087 mW/g**

Maximum value of SAR (measured) = 0.152 mW/g

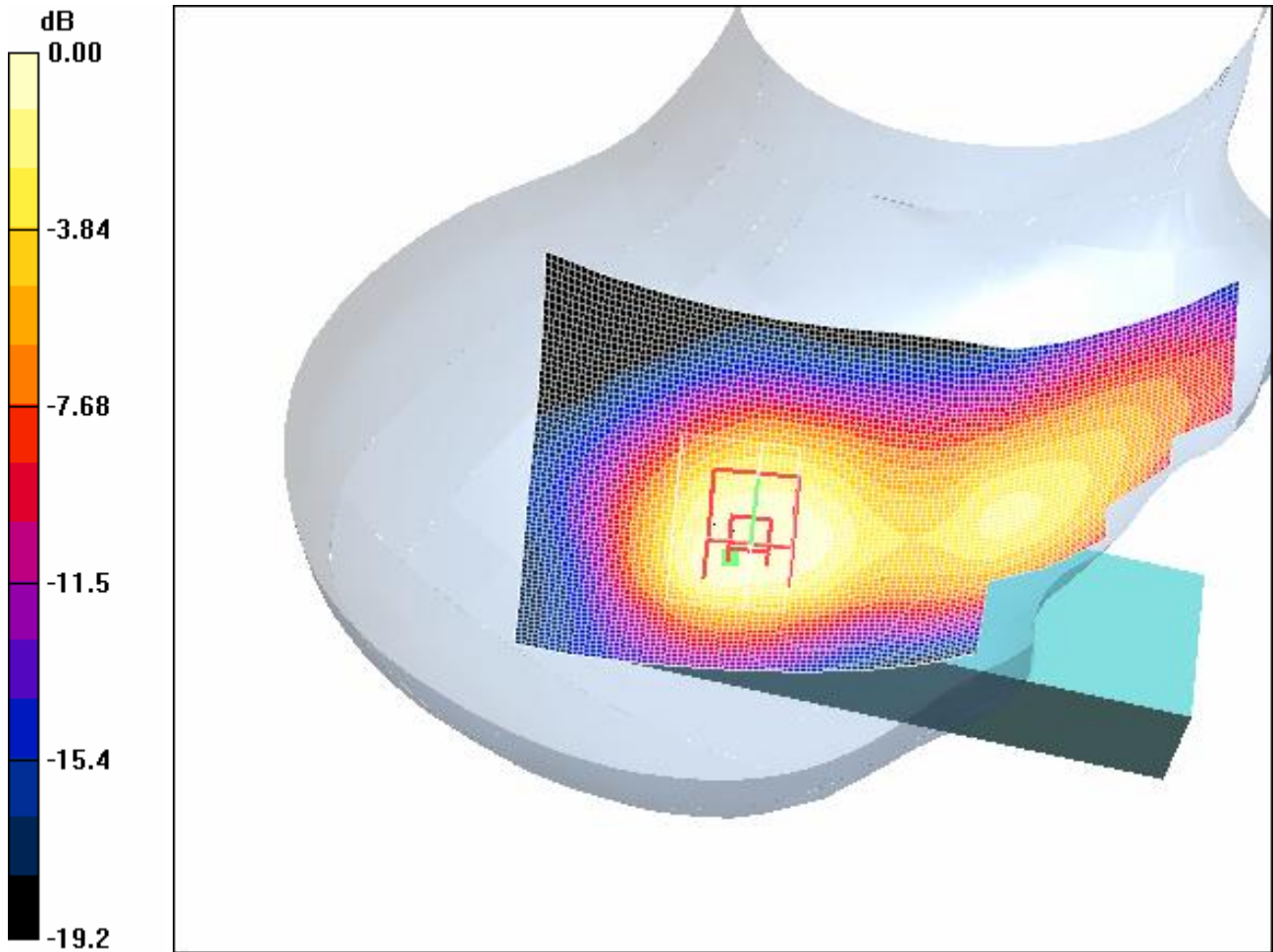

0 dB = 0.152mW/g

#### **4.28 FCC-OET65-Body-Worn-GSM1900-Low**

Date/Time: 2005-9-21 19:18:42 Date/Time: 2005-9-21 19:24:24

Test Laboratory: SGS-GSM

#### **FCC-OET65-Body-Worn-GSM1900-Low**

**DUT: GSM50084-Body; Type: Body; Serial: 20050921**

Communication System: DCS1900-GSM Mode; Frequency: 1850.2 MHz; Duty Cycle: 1:8.3  
Medium: HSL1900 Medium parameters used:  $f = 1850.2$  MHz;  $\sigma = 1.49$  mho/m;  $\epsilon_r = 51.6$ ;  $\rho$

= 1000 kg/m<sup>3</sup>

Phantom section: Flat Section

Measurement Standard: DASY4 (High Precision Assessment)

DASY4 Configuration:

- Probe: ET3DV6 - SN1774; ConvF(4.66, 4.66, 4.66); Calibrated: 2004-10-26
- Sensor-Surface: 4mm (Mechanical Surface Detection)
- Electronics: DAE4 Sn611;
- Phantom: SAM 12; Type: SAM V4.0; Serial: TP-1283
- Measurement SW: DASY4, V4.5 Build 19; Postprocessing SW: SEMCAD, V1.8 Build 146

**Body Worn - Low/Area Scan (51x91x1):** Measurement grid: dx=15mm, dy=15mm  
Maximum value of SAR (interpolated) = 0.304 mW/g

**Body Worn - Low/Zoom Scan (7x7x7) (7x7x7)/Cube 0:** Measurement grid:  
dx=5mm, dy=5mm, dz=5mm

Reference Value = 8.00 V/m; Power Drift = -0.102 dB

Peak SAR (extrapolated) = 0.383 W/kg

**SAR(1 g) = 0.272 mW/g; SAR(10 g) = 0.175 mW/g**

Maximum value of SAR (measured) = 0.295 mW/g

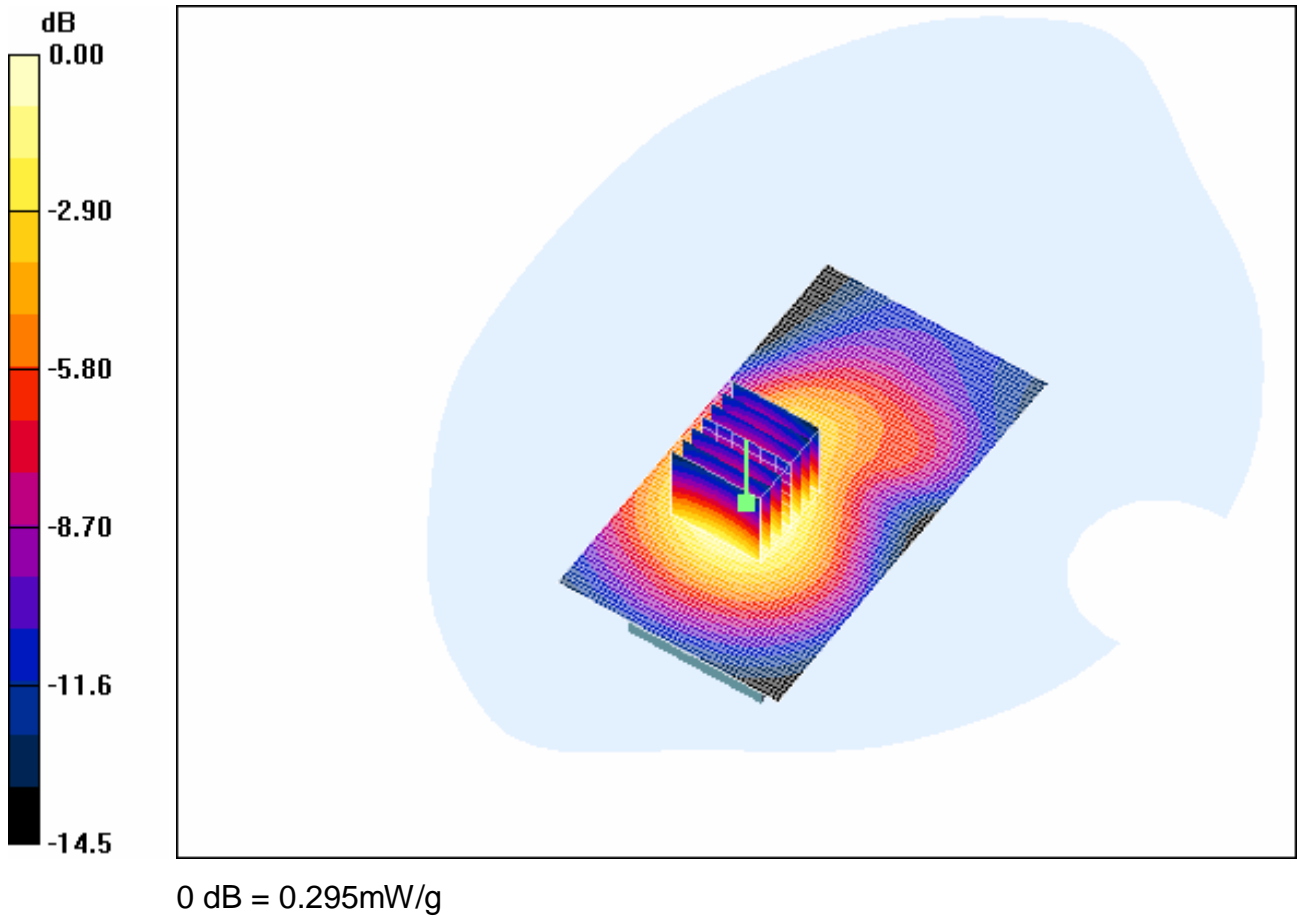

#### **4.29 FCC-OET65-Body-Worn-GSM1900-Mid**

Date/Time: 2005-9-21 19:59:31 Date/Time: 2005-9-21 20:05:11

Test Laboratory: SGS-GSM

#### **FCC-OET65-Body-Worn-GSM1900-Mid**

**DUT: GSM50084-Body; Type: Body; Serial: 20050921**

Communication System: DCS1900-GSM Mode; Frequency: 1880 MHz; Duty Cycle: 1:8.3  
Medium: HSL1900 Medium parameters used:  $f = 1880$  MHz;  $\sigma = 1.52$  mho/m;  $\epsilon_r = 51.5$ ;  $\rho = 1000$  kg/m<sup>3</sup>

Phantom section: Flat Section

Measurement Standard: DASY4 (High Precision Assessment)

DASY4 Configuration:

- Probe: ET3DV6 - SN1774; ConvF(4.66, 4.66, 4.66); Calibrated: 2004-10-26
- Sensor-Surface: 4mm (Mechanical Surface Detection)
- Electronics: DAE4 Sn611;
- Phantom: SAM 12; Type: SAM V4.0; Serial: TP-1283
- Measurement SW: DASY4, V4.5 Build 19; Postprocessing SW: SEMCAD, V1.8 Build 146

**Body Worn - Middle/Area Scan (51x91x1):** Measurement grid: dx=15mm, dy=15mm  
Maximum value of SAR (interpolated) = 0.281 mW/g

**Body Worn - Middle/Zoom Scan (7x7x7)/Cube 0:** Measurement grid: dx=5mm,  
dy=5mm, dz=5mm

Reference Value = 8.66 V/m; Power Drift = -0.066 dB

Peak SAR (extrapolated) = 0.408 W/kg

**SAR(1 g) = 0.279 mW/g; SAR(10 g) = 0.173 mW/g**

Maximum value of SAR (measured) = 0.308 mW/g

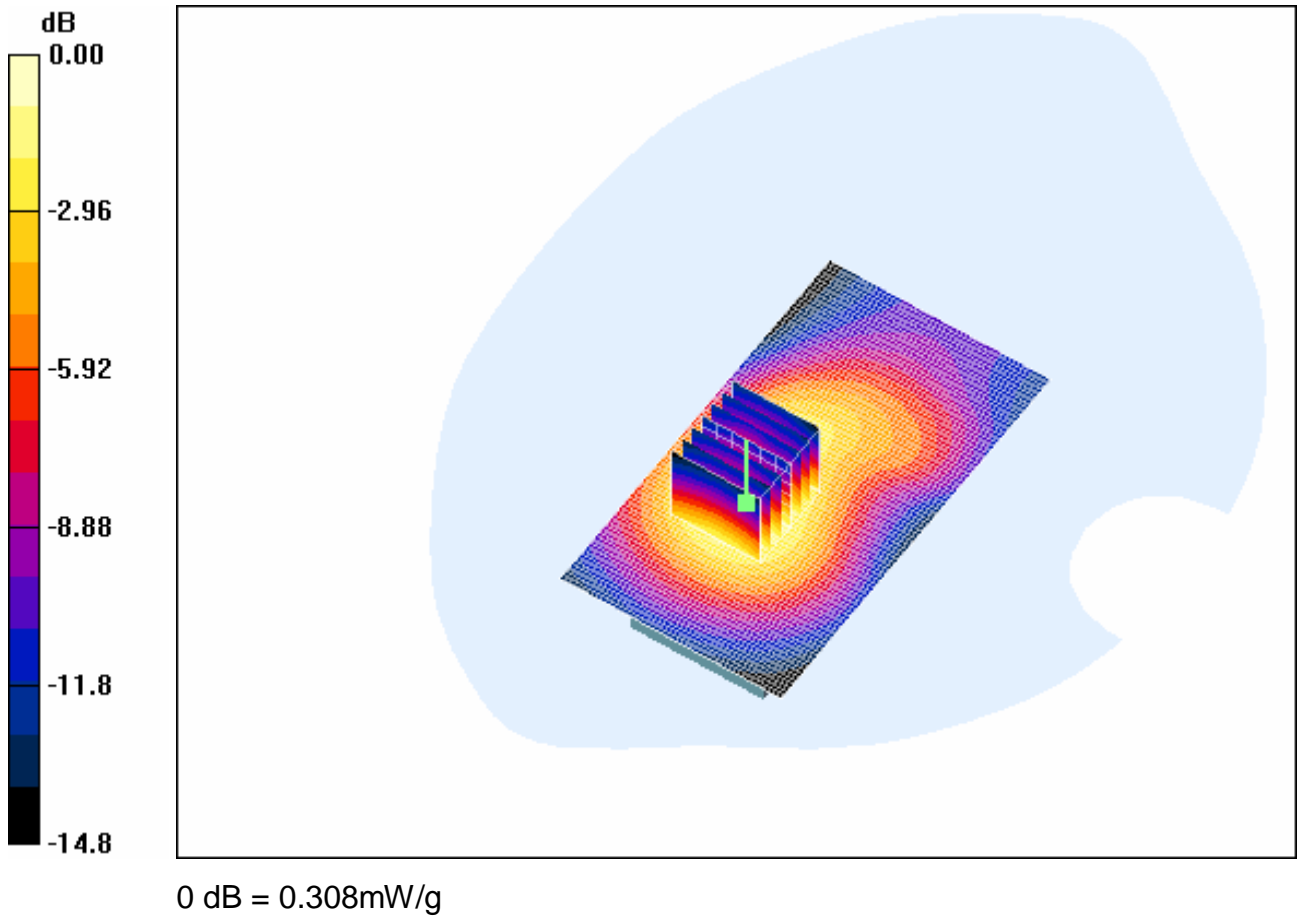

#### **4.30 FCC-OET65-Body-Worn-GSM1900-High**

Date/Time: 2005-9-21 21:05:50 Date/Time: 2005-9-21 21:11:33

Test Laboratory: SGS-GSM

#### **FCC-OET65-Body-Worn-GSM1900-High**

**DUT: GSM50084-Body; Type: Body; Serial: 20050921**

Communication System: DCS1900-GSM Mode; Frequency: 1909.8 MHz; Duty Cycle: 1:8.3  
Medium: HSL1900 Medium parameters used:  $f = 1909.8$  MHz;  $\sigma = 1.55$  mho/m;  $\epsilon_r = 51.5$ ;  $\rho = 1000$  kg/m<sup>3</sup>

Phantom section: Flat Section

Measurement Standard: DAS4 (High Precision Assessment)

DASY4 Configuration:

- Probe: ET3DV6 - SN1774; ConvF(4.66, 4.66, 4.66); Calibrated: 2004-10-26
- Sensor-Surface: 4mm (Mechanical Surface Detection)
- Electronics: DAE4 Sn611;
- Phantom: SAM 12; Type: SAM V4.0; Serial: TP-1283
- Measurement SW: DASY4, V4.5 Build 19; Postprocessing SW: SEMCAD, V1.8 Build 146

**Body Worn - High/Area Scan (51x91x1):** Measurement grid: dx=15mm, dy=15mm  
Maximum value of SAR (interpolated) = 0.265 mW/g

**Body Worn - High/Zoom Scan (7x7x7) (7x7x7)/Cube 0:** Measurement grid:  
dx=5mm, dy=5mm, dz=5mm

Reference Value = 8.40 V/m; Power Drift = -0.00 dB

Peak SAR (extrapolated) = 0.388 W/kg

**SAR(1 g) = 0.259 mW/g; SAR(10 g) = 0.158 mW/g**

Maximum value of SAR (measured) = 0.284 mW/g



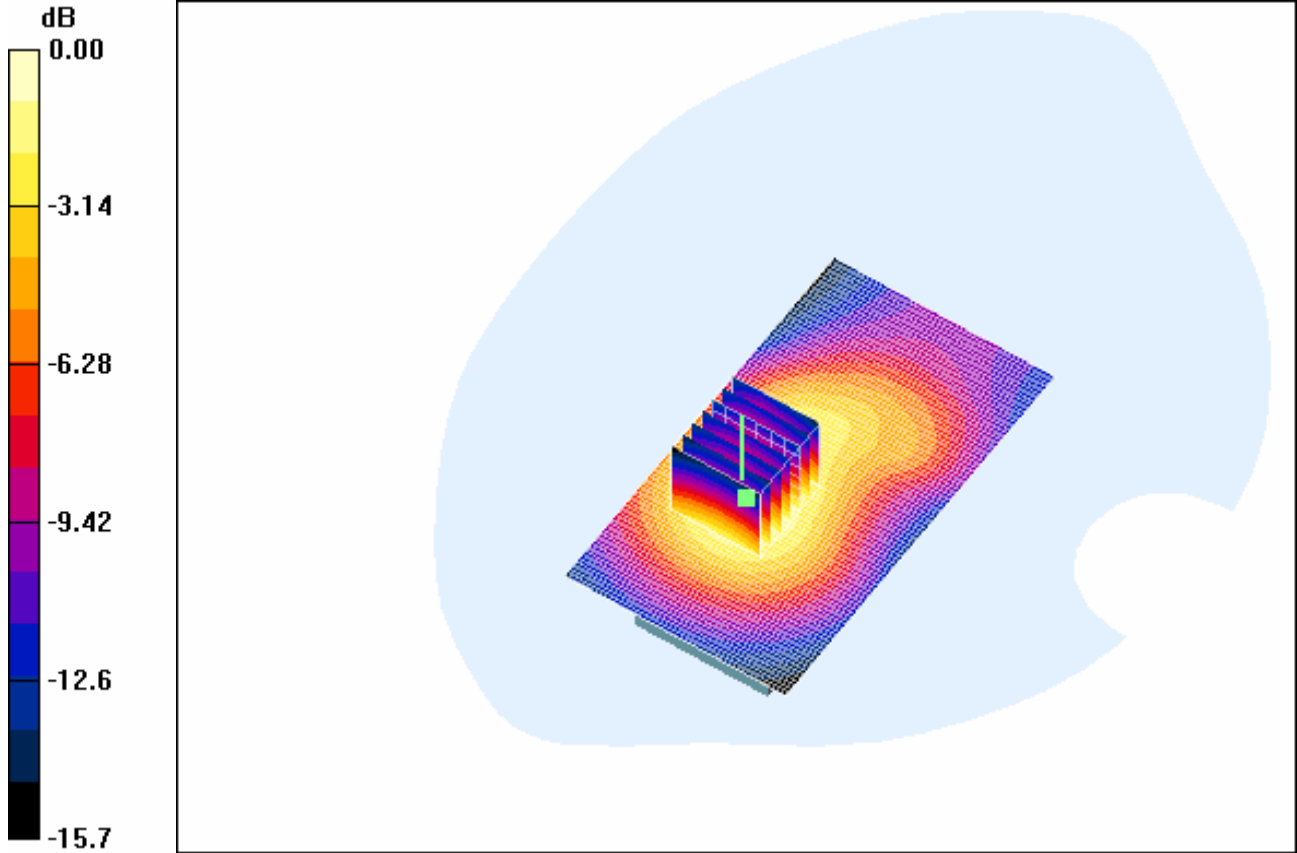

0 dB = 0.284mW/g

# Appendix

## 1. Photographs of Test Setup

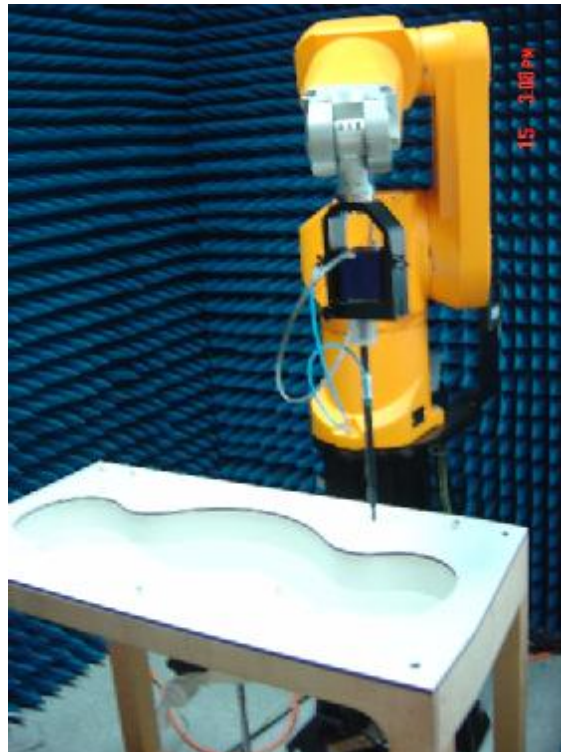

Fig.1 Photograph of the SAR measurement System

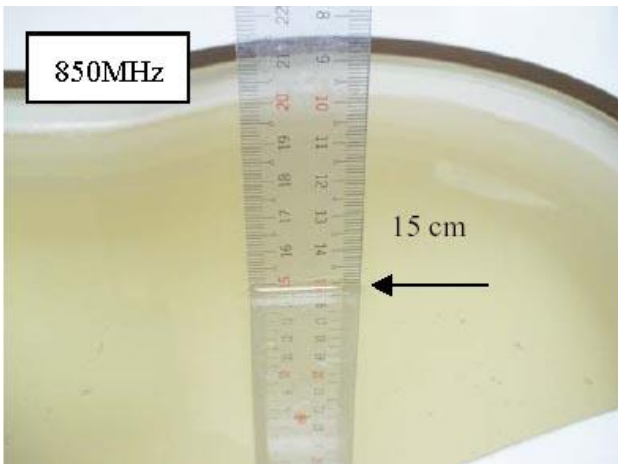

Fig.2 Photograph of the Tissue Simulant Fluid Liquid depth 15cm for Left-Head Side

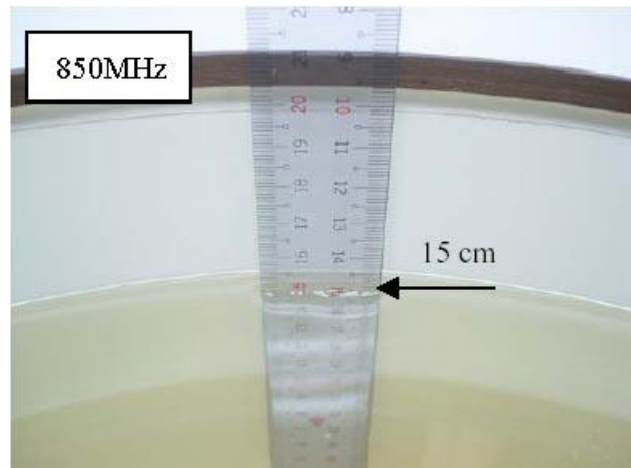

Fig.3 Photograph of the Tissue Simulant Liquid depth 15cm for Body-Worn

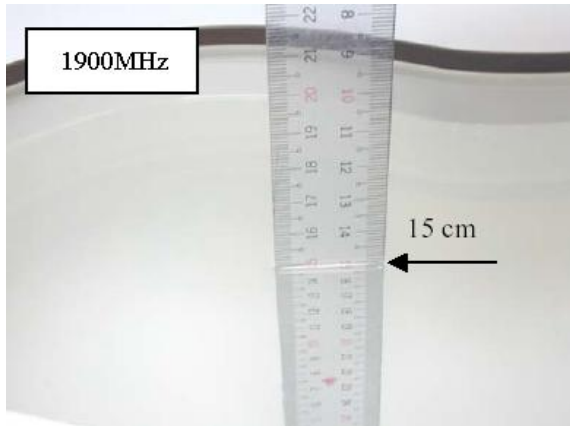

Fig.4 Photograph of the Tissue Simulant Fluid Fluid Liquid depth 15cm for Right-Head Side

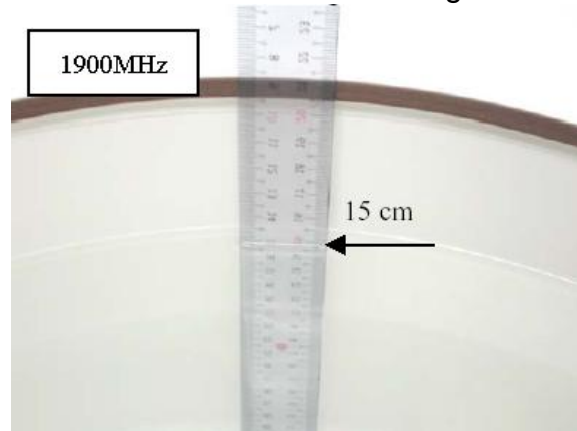

Fig.5 Photograph of the Tissue Simulant Liquid depth 15cm for Body-Worn

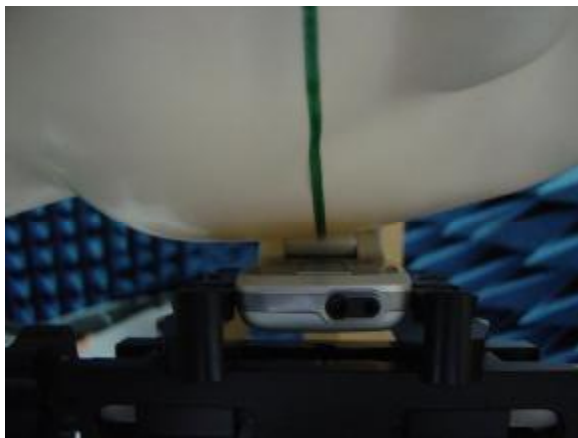

Fig.6 Photograph of the Left Hand Side Touch status

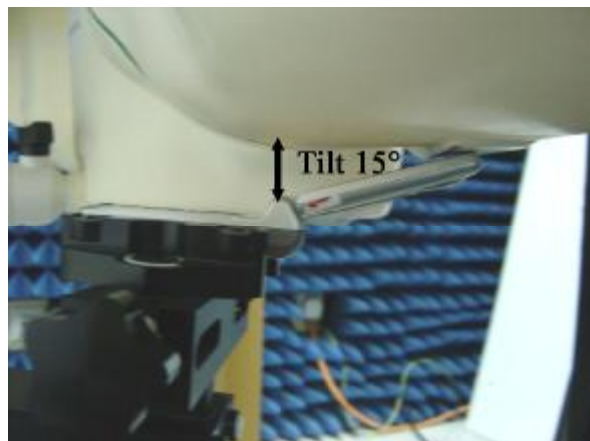
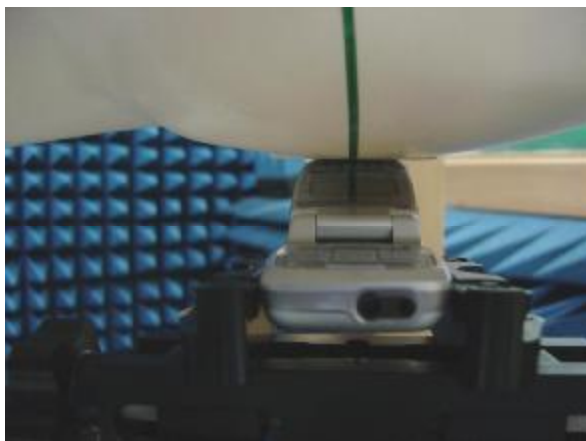

Fig.7 Photograph of the Left Hand Side Tilt status

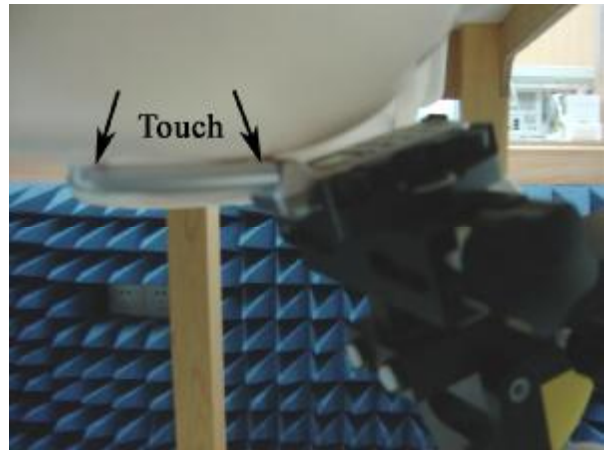
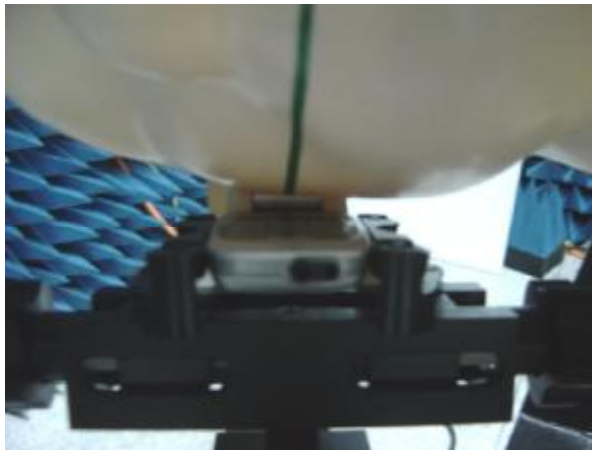

Fig.8 Photograph of the Right Hand Side Touch status

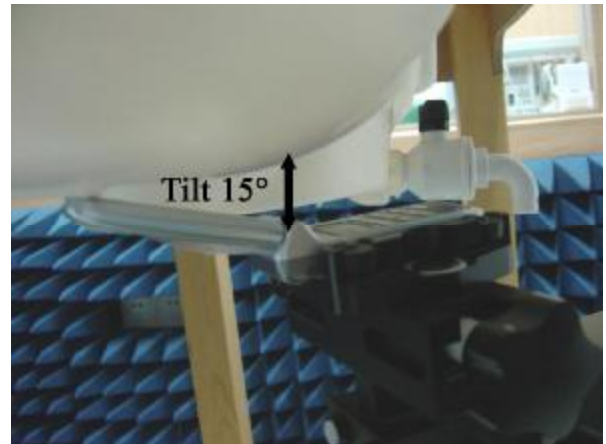
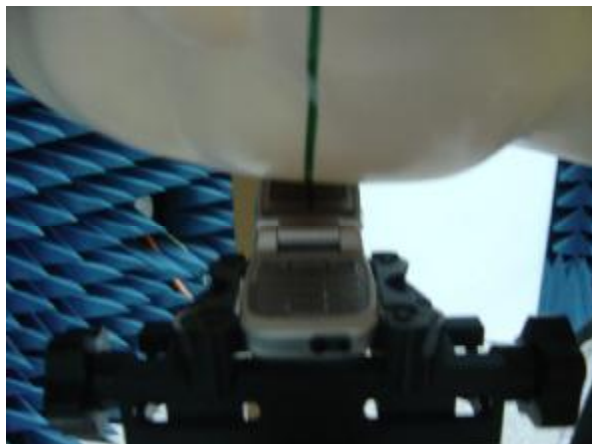

Fig.9 Photograph of the Right Hand Side Tilt status

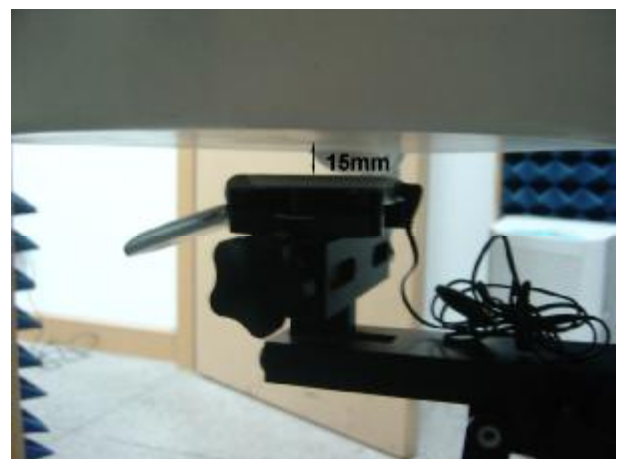
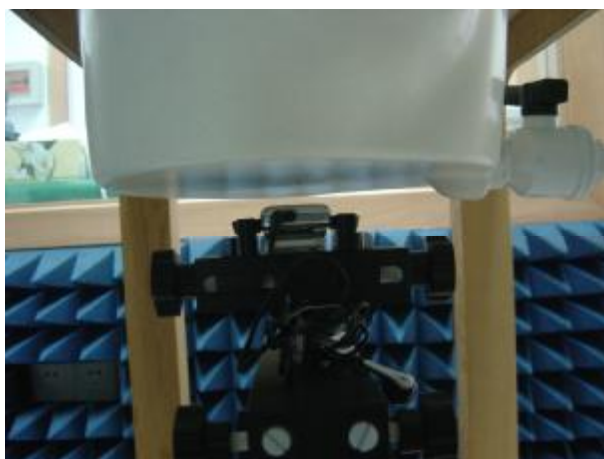

Fig.10 Photograph of the BodyWorn status

## 2. Photographs of the EUT



Fig.11 Front View



Fig.12 Back View

## 3. Photographs of the battery



Fig.13 Front view of battery



Fig.14 Back view of battery

**4. Photograph of the charger**



Fig.15 Charger

**5. Probe Calibration certificate**

**Calibration Laboratory of  
 Schmid & Partner  
 Engineering AG**  
 Zeughausstrasse 43, 8004 Zurich, Switzerland



**S** Schweizerischer Kalibrierdienst  
**S** Service suisse d'étalonnage  
**C** Servizio svizzero di taratura  
**S** Swiss Calibration Service

Accredited by the Swiss Federal Office of Metrology and Accreditation  
 The Swiss Accreditation Service is one of the signatories to the EA  
 Multilateral Agreement for the recognition of calibration certificates

Accreditation No.: **SCS 108**

Client **SGS China (Auden)**

Certificate No: **ET3-1774\_Oct04**

**CALIBRATION CERTIFICATE**

Object: **ET3DV6 - SN:1774**

Calibration procedure(s): **QA CAL-01.v5  
 Calibration procedure for dosimetric E-field probes**

Calibration date: **October 26, 2004**

Condition of the calibrated item: **In Tolerance**

This calibration certificate documents the traceability to national standards, which realize the physical units of measurements (SI).  
 The measurements and the uncertainties with confidence probability are given on the following pages and are part of the certificate.

All calibrations have been conducted in the closed laboratory facility: environment temperature (22 ± 3)°C and humidity < 70%.

Calibration Equipment used (M&TE critical for calibration)

Primary Standards	ID #	Cal Date (Calibrated by, Certificate No.)	Scheduled Calibration
Power meter E4419B	GB41293674	5-May-04 (METAS, No. 251-00388)	May-05
Power sensor E4412A	MY41495277	5-May-04 (METAS, No. 251-00388)	May-05
Reference 3 dB Attenuator	SN: S5054 (3c)	3-Apr-03 (METAS, No. 251-00403)	Aug-05
Reference 20 dB Attenuator	SN: S5086 (20b)	3-May-04 (METAS, No. 251-00389)	May-05
Reference 30 dB Attenuator	SN: S5129 (30b)	3-Apr-03 (METAS, No. 251-00404)	Aug-05
Reference Probe ES3DV2	SN: 3013	8-Jan-04 (SPEAG, No. ES3-3013_Jan04)	Jan-05
DAE4	SN: 617	26-May-04 (SPEAG, No. DAE4-617_May04)	May-05

Secondary Standards	ID #	Check Date (in house)	Scheduled Check
Power sensor HP 8481A	MY41092180	18-Sep-02 (SPEAG, in house check Oct-03)	In house check: Oct 05
RF generator HP 8648C	US3642U01700	4-Aug-99 (SPEAG, in house check Dec-03)	In house check: Dec-05
Network Analyzer HP 8753E	US37390585	18-Oct-01 (SPEAG, in house check Nov-03)	In house check: Nov 04

Calibrated by:	Name	Function	Signature
	Nico Vetterli	Laboratory Technician	
Approved by:	Katja Pokovic	Technical Manager	

Issued: October 26, 2004

This calibration certificate shall not be reproduced except in full without written approval of the laboratory.

ET3DV6 SN:1774

October 26, 2004

# Probe ET3DV6

## SN:1774

Manufactured:	April 15, 2003
Last calibrated:	May 23, 2003
Repaired:	October 18, 2004
Recalibrated:	October 26, 2004

Calibrated for DASY Systems

(Note: non-compatible with DASY2 system!)



ET3DV6 SN:1774

October 26, 2004

## DASY - Parameters of Probe: ET3DV6 SN:1774

Sensitivity in Free Space <sup>A</sup>			Diode Compression <sup>B</sup>	
NormX	1.92 ± 9.9%	$\mu\text{V}/(\text{V}/\text{m})^2$	DCP X	93 mV
NormY	1.80 ± 9.9%	$\mu\text{V}/(\text{V}/\text{m})^2$	DCP Y	93 mV
NormZ	1.72 ± 9.9%	$\mu\text{V}/(\text{V}/\text{m})^2$	DCP Z	93 mV

### Sensitivity in Tissue Simulating Liquid (Conversion Factors)

Please see Page 8.

#### Boundary Effect

**TSL**                      **900 MHz**      **Typical SAR gradient: 5 % per mm**

Sensor Center to Phantom Surface Distance		<b>3.7 mm</b>	<b>4.7 mm</b>
SAR <sub>bc</sub> [%]	Without Correction Algorithm	8.8	4.6
SAR <sub>bc</sub> [%]	With Correction Algorithm	0.7	0.1

**TSL**                      **1750 MHz**      **Typical SAR gradient: 10 % per mm**

Sensor Center to Phantom Surface Distance		<b>3.7 mm</b>	<b>4.7 mm</b>
SAR <sub>bc</sub> [%]	Without Correction Algorithm	12.5	8.3
SAR <sub>bc</sub> [%]	With Correction Algorithm	0.7	0.1

#### Sensor Offset

Probe Tip to Sensor Center                      **2.7 mm**

**The reported uncertainty of measurement is stated as the standard uncertainty of measurement multiplied by the coverage factor k=2, which for a normal distribution corresponds to a coverage probability of approximately 95%.**

<sup>A</sup> The uncertainties of NormX,Y,Z do not affect the E<sup>2</sup>-field uncertainty inside TSL (see Page 8).

<sup>B</sup> Numerical linearization parameter; uncertainty not required.

ET3DV6 SN:1774

October 26, 2004

## Frequency Response of E-Field

(TEM-Cell:ifi110 EXX, Waveguide: R22)

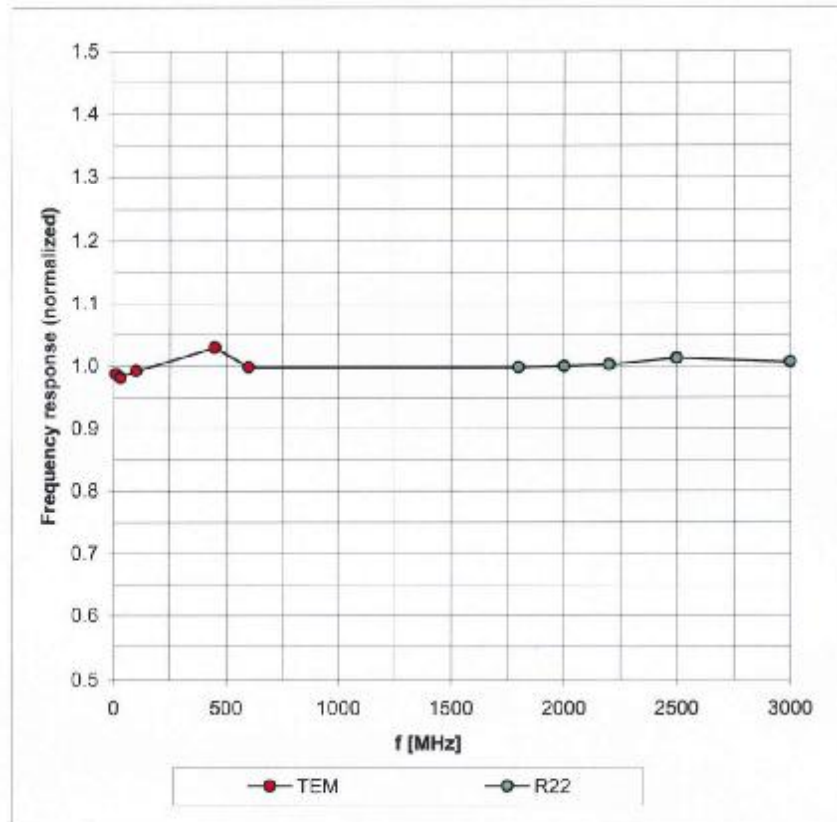

Uncertainty of Frequency Response of E-field:  $\pm 6.3\%$  ( $k=2$ )

ET3DV6 SN:1774

October 26, 2004

### Dynamic Range f(SAR<sub>head</sub>) (Waveguide R22, f = 1800 MHz)

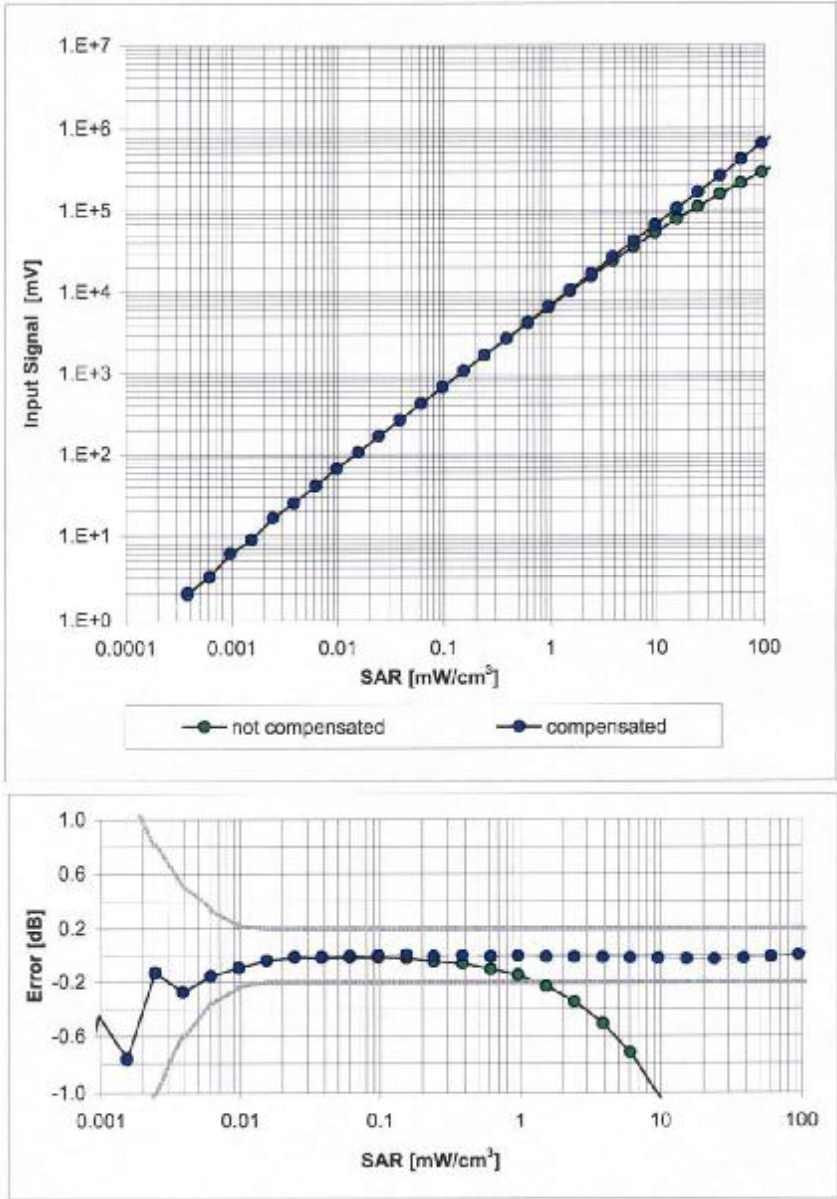

Uncertainty of Linearity Assessment: ± 0.6% (k=2)

ET3DV6 SN:1774

October 26, 2004

## Conversion Factor Assessment

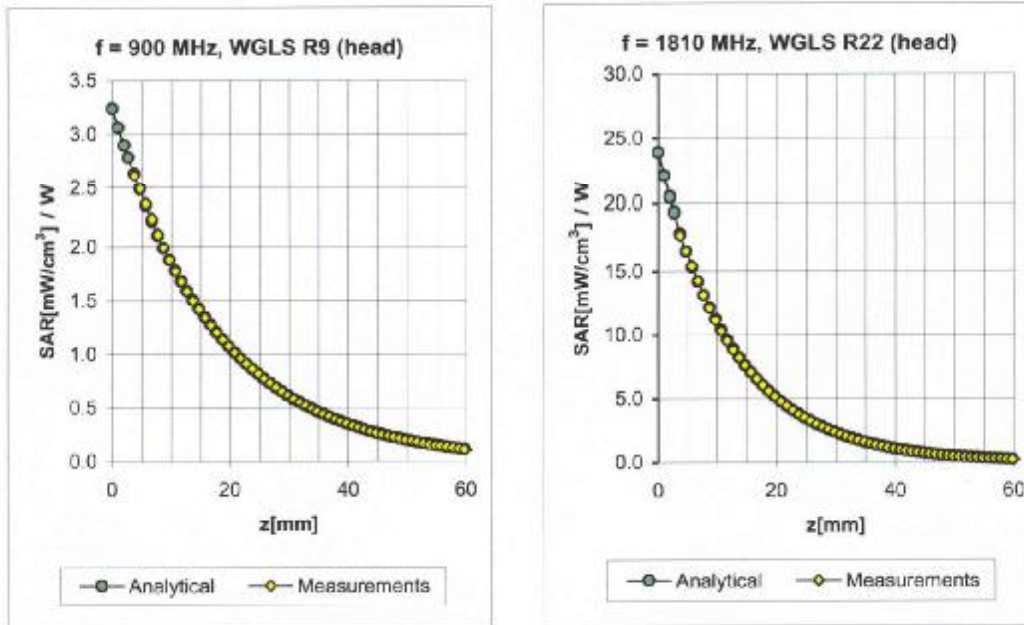

f [MHz]	Validity [MHz] <sup>c</sup>	TSL	Permittivity	Conductivity	Alpha	Depth	ConvF Uncertainty
835	± 50 / ± 100	Head	41.5 ± 5%	0.90 ± 5%	1.13	1.42	6.96 ± 11.0% (k=2)
900	± 50 / ± 100	Head	41.5 ± 5%	0.97 ± 5%	1.09	1.46	6.61 ± 11.0% (k=2)
1750	± 50 / ± 100	Head	40.0 ± 5%	1.40 ± 5%	0.58	2.31	5.48 ± 11.0% (k=2)
1900	± 50 / ± 100	Head	40.0 ± 5%	1.40 ± 5%	0.54	2.52	5.25 ± 11.0% (k=2)
2450	± 50 / ± 100	Head	39.2 ± 5%	1.80 ± 5%	0.63	2.30	4.70 ± 11.8% (k=2)
835	± 50 / ± 100	Body	55.2 ± 5%	0.97 ± 5%	0.96	1.58	6.65 ± 11.0% (k=2)
900	± 50 / ± 100	Body	55.0 ± 5%	1.05 ± 5%	1.00	1.57	6.36 ± 11.0% (k=2)
1750	± 50 / ± 100	Body	53.3 ± 5%	1.52 ± 5%	0.52	2.81	4.79 ± 11.0% (k=2)
1900	± 50 / ± 100	Body	53.3 ± 5%	1.52 ± 5%	0.52	2.98	4.66 ± 11.0% (k=2)
2450	± 50 / ± 100	Body	52.7 ± 5%	1.95 ± 5%	0.62	2.18	4.35 ± 11.8% (k=2)

<sup>c</sup> The validity of ± 100 MHz only applies for DASY 4.3 B17 and higher (see Page 2). The uncertainty is the RSS of the ConvF uncertainty at calibration frequency and the uncertainty for the indicated frequency band.

ET3DV6 SN:1774

October 26, 2004

### Deviation from Isotropy in HSL

Error ( $\phi$ ,  $\theta$ ),  $f = 900$  MHz

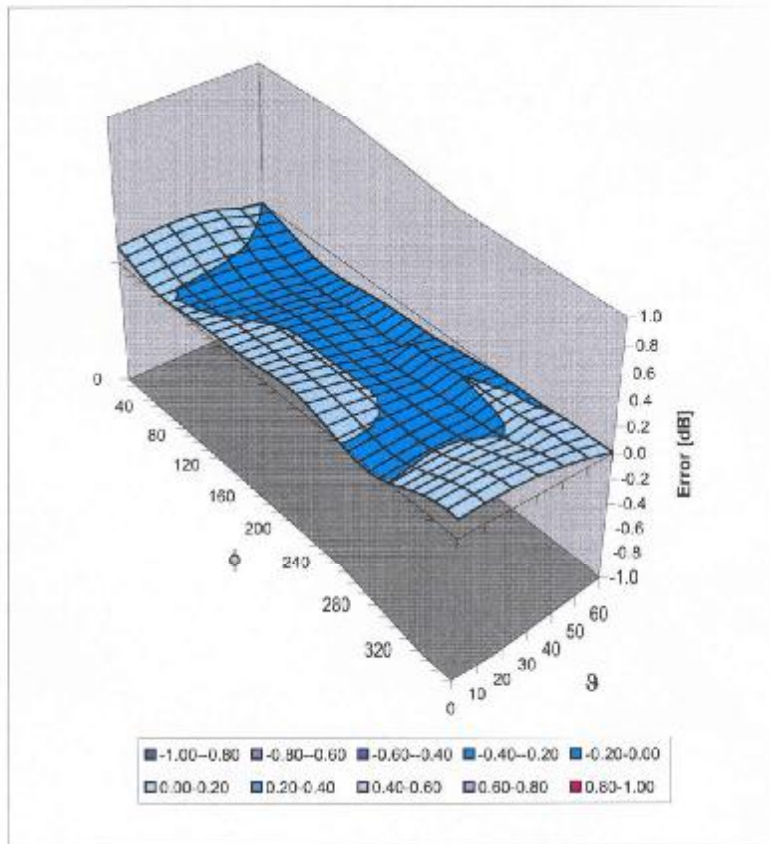

Uncertainty of Spherical Isotropy Assessment:  $\pm 2.6\%$  ( $k=2$ )

ET3DV6 SN:1774

October 26, 2004

Receiving Pattern ( $\phi$ ),  $\theta = 0^\circ$

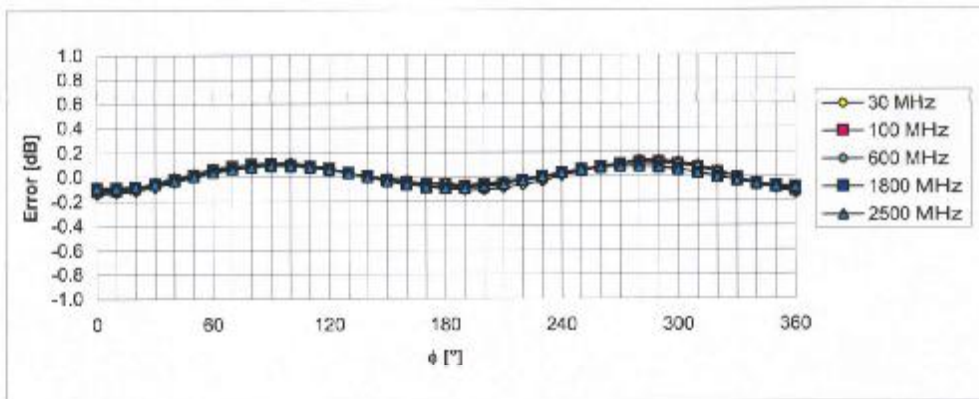
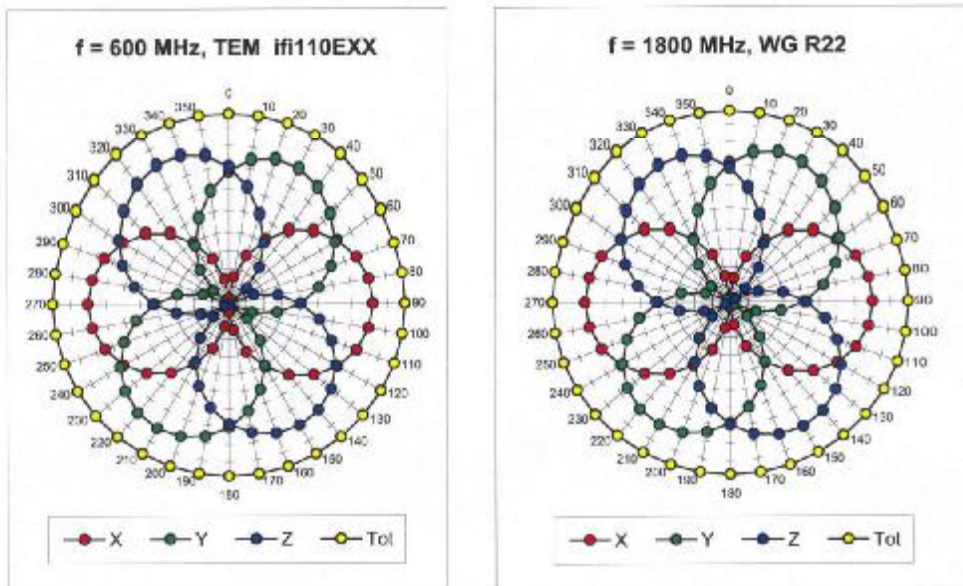

Uncertainty of Axial Isotropy Assessment:  $\pm 0.5\%$  ( $k=2$ )

## 6. Uncertainty analysis

Error Description	Tol. (± %)	Prob. dist.	Div.	( $c_1$ ) (1g)	( $c_2$ ) (10g)	Std. unc. (± %)		( $v_i$ )
Std. unc. (1g)		Std. unc. (10g)						
<b>Measurement System</b>								
Probe Calibration	4.8	N	1	1	1	4.8	4.8	∞
Axial Isotropy	4.7	R	$\sqrt{3}$	1	1	2.7	2.7	∞
Hemispherical Isotropy	0	R	$\sqrt{3}$	1	1	0	0	∞
Boundary Effects	1.0	R	$\sqrt{3}$	1	1	0.6	0.6	∞
Linearity	4.7	R	$\sqrt{3}$	1	1	2.7	2.7	∞
System Detection Limit	1.0	R	$\sqrt{3}$	1	1	0.6	0.6	∞
Readout Electronics	1.0	N	1	1	1	1.0	1.0	∞
Response Time	0	R	$\sqrt{3}$	1	1	0	0	∞
Integration Time	0	R	$\sqrt{3}$	1	1	0	0	∞
RF Ambient Conditions	3.0	R	$\sqrt{3}$	1	1	1.7	1.7	∞
Probe Positioner	0.4	R	$\sqrt{3}$	1	1	0.2	0.2	∞
Probe Positioning	2.9	R	$\sqrt{3}$	1	1	1.7	1.7	∞
Algorithms for Max. SAR Eval.	1.0	R	$\sqrt{3}$	1	1	0.6	0.6	∞
<b>Dipole</b>								
Dipole Axis to Liquid Distance	2.0	R	$\sqrt{3}$	1	1	1.2	1.2	∞
Input power and SAR drift meas.	4.7	R	$\sqrt{3}$	1	1	2.7	2.7	∞
<b>Phantom and Tissue Param.</b>								
Phantom Uncertainty	4.0	R	$\sqrt{3}$	1	1	2.3	2.3	∞
Liquid Conductivity (target)	5.0	R.	$\sqrt{3}$	0.64	0.43	1.8	1.2	∞
Liquid Conductivity (meas.)	2.5	N	1	0.64	0.43	1.6	1.1	∞
Liquid Permittivity (target)	5.0	R	$\sqrt{3}$	0.6	0.49	1.7	1.4	∞
Liquid Permittivity (meas.)	2.5	N	1	0.6	0.49	1.5	1.2	∞
<b>Combined Standard Uncertainty</b>						<b>8.4</b>	<b>8.1</b>	<b>∞</b>
<b>Coverage Factor for 95%</b>		<b>kp=2</b>						
<b>Expanded Uncertainty</b>						<b>16.8</b>	<b>16.2</b>	

Dasy4 Uncertainty Budget

7. Phantom description

**Schmid & Partner  
 Engineering AG**

Zeughausstrasse 43, 8004 Zurich, Switzerland, Phone +41 1 245 97 00, Fax +41 1 245 97 79

**Certificate of conformity / First Article Inspection**

Item	SAM Twin Phantom V4.0
Type No	QD 000 P40 CA
Series No	TP-1150 and higher
Manufacturer / Origin	Unterse Composite Hauptstr. 69 CH-8559 Fruttwilen Switzerland

**Tests**

The series production process used allows the limitation to test of first articles. Complete tests were made on the pre-series Type No. QD 000 P40 AA, Serial No. TP-1001 and on the series first article Type No. QD 000 P40 BA, Serial No. TP-1006. Certain parameters have been retested using further series units (called samples).

Test	Requirement	Details	Units tested
Shape	Compliance with the geometry according to the CAD model.	ITIS CAD File (*)	First article, Samples
Material thickness	Compliant with the requirements according to the standards	2mm +/- 0.2mm in specific areas	First article, Samples
Material parameters	Dielectric parameters for required frequencies	200 MHz - 3 GHz Relative permittivity < 5 Loss tangent < 0.05.	Material sample TP 104-5
Material resistivity	The material has been tested to be compatible with the liquids defined in the standards	Liquid type HSL 1800 and others according to the standard.	Pre-series, First article

**Standards**

- [1] GENELEC EN 50361
- [2] IEEE P1528-200x draft 6.5
- [3] IEC PT 62209 draft 0.9
- (\*) The ITIS CAD file is derived from [2] and is also within the tolerance requirements of the shapes of [1] and [3].

**Conformity**

Based on the sample tests above, we certify that this item is in compliance with the uncertainty requirements of SAR measurements specified in standard [1] and draft standards [2] and [3].

Date 28.02.2002

Signature / Stamp

*F. Rombult*

**Schmid & Partner  
 Engineering AG**

Zeughausstrasse 43, CH-8004 Zurich  
 Tel. +41 1 245 97 00, Fax +41 1 245 97 79

*Volker Kapp*

**The end**