



PART 2 Test Under Dynamic Transmission Condition

No. 24T04Z100472-015

For

Guangdong OPPO Mobile Telecommunications Corp., Ltd.

Mobile Phone

Model Name: CPH2625

with

Hardware Version: 11

Software Version: ColorOS 14.1

FCC ID: R9C-OP23262

Issued Date: 2024-05-16

Note:

The test results in this test report relate only to the devices specified in this report. This report shall not be reproduced except in full without the written approval of CTTL.

Test Laboratory:

CTTL, Telecommunication Technology Labs, CAICT

No. 52, Huayuan North Road, Haidian District, Beijing, P. R. China 100191.

Tel:+86(0)10-62304633-2512, Fax:+86(0)10-62304633-2504

Email: cttl_terminals@caict.ac.cn, website: www.caict.ac.cn

©Copyright. All rights reserved by CTTL.



REPORT HISTORY

Report Number	Revision	Issue Date	Description
24T04Z100472-015	Rev.0	2024-05-16	Initial creation of test report

TABLE OF CONTENT

1 TEST LABORATORY	5
1.1. INTRODUCTION & ACCREDITATION	5
1.2. TESTING LOCATION	5
1.3. TESTING ENVIRONMENT	5
1.4. PROJECT DATA	5
1.5. SIGNATURE	5
2 INTRODUCTION	6
3 OPERATING PARAMETERS FOR ALGORITHM VALIDATION	7
4 OVERVIEW OF TA-SAR	8
5 TA-SAR TEST SCENARIOS AND TEST PROCEDURES	9
5.1 TEST SEQUENCES FOR ALL SCENARIOS	10
5.2 TEST CONFIGURATION AND PROCEDURE FOR SCENARIO 1: RANGE OF TA-SAR PARAMETERS VIA CONDUCTED POWER MEASUREMENTS.....	15
5.3 TEST CONFIGURATION AND PROCEDURE FOR SCENARIO 2: TIME-VARYING TX POWER VIA CONDUCTED POWER MEASUREMENTS.....	17
5.4 TEST CONFIGURATION AND PROCEDURE FOR SCENARIO 3: CALL DISCONNECTION AND RE-ESTABLISHMENT VIA CONDUCTED POWER MEASUREMENTS	20
5.5 TEST CONFIGURATION AND PROCEDURE FOR SCENARIO 4: BAND HANDOVER VIA CONDUCTED POWER MEASUREMENTS	22
5.6 TEST CONFIGURATION AND PROCEDURE FOR SCENARIO 5: EXPOSURE CONDITION INDEX (ECI) CHANGE VIA CONDUCTED POWER MEASUREMENTS.....	24
5.7 TEST CONFIGURATION AND PROCEDURE FOR SCENARIO 6: ANTENNA SWITCHING VIA CONDUCTED POWER MEASUREMENTS	25
5.8 TEST CONFIGURATION AND PROCEDURE FOR SCENARIO 7: TIME WINDOW SWITCHING VIA CONDUCTED POWER MEASUREMENTS.....	26
5.9 TEST CONFIGURATION AND PROCEDURE FOR SCENARIO 8: SAR EXPOSURE SWITCHING VIA CONDUCTED POWER MEASUREMENTS.....	29
5.10 TEST CONFIGURATION AND PROCEDURE FOR SCENARIO 2: TIME-VARYING TX POWER VIA SAR MEASUREMENTS	32
6 TA-SAR VALIDATION VIA CONDUCTED POWER MEASUREMENTS	34
6.1 MEASUREMENT SETUP	34
6.2 CONDUCTED POWER MEASUREMENT RESULTS FOR SCENARIO 1: RANGE OF TA-SAR PARAMETERS	41
6.3 CONDUCTED POWER MEASUREMENT RESULTS FOR SCENARIO 2: TIME-VARYING TX POWER.....	43
6.4 CONDUCTED POWER MEASUREMENT RESULTS FOR SCENARIO 3: CALL DISCONNECTION AND RE-ESTABLISHMENT	64
6.5 CONDUCTED POWER MEASUREMENT RESULTS FOR SCENARIO 4: BAND HANDOVER.....	66
6.6 CONDUCTED POWER MEASUREMENT RESULTS FOR SCENARIO 5: ECI CHANGE	68
6.7 CONDUCTED POWER MEASUREMENT RESULTS FOR SCENARIO 6: ANTENNA HANDOVER	70



6.8 CONDUCTED POWER MEASUREMENT RESULTS FOR SCENARIO 7: SAR EXPOSURE SWITCHING..... 72

7 TA-SAR VALIDATION VIA SAR MEASUREMENTS..... 74

7.1 MEASUREMENT SETUP 74

7.2 SAR MEASUREMENT RESULTS FOR SCENARIO 2: TIME-VARYING TX POWER..... 75

8 CONCLUSIONS..... 92

APPENDIX A PICTURES OF TA-SAR MEASUREMENT BENCH 93

APPENDIX B MAIN TEST INSTRUMENTS..... 96

APPENDIX C TISSUE SIMULATING LIQUIDS 97

APPENDIX D SYSTEM VALIDATION 97

APPENDIX E SYSTEM VALIDATION RESULTS 98

ANNEX F PROBE CALIBRATION CERTIFICATE 101

ANNEX G DIPOLE CALIBRATION CERTIFICATE 110

APPENDIX H ACCREDITATION CERTIFICATE 128

1 Test Laboratory

1.1. Introduction & Accreditation

Telecommunication Technology Labs, CAICT is an ISO/IEC 17025:2017 accredited test laboratory under American Association for Laboratory Accreditation (A2LA) with lab code 7049.01, and is also an FCC accredited test laboratory (CN1349), and ISED accredited test laboratory (CAB identifier:CN0066). The detail accreditation scope can be found on A2LA website.

1.2. Testing Location

Location 1: CTTL(huayuan North Road)

Address: No. 52, Huayuan North Road, Haidian District, Beijing,
P. R. China 100191

1.3. Testing Environment

Normal Temperature: 15-35°C
Extreme Temperature: -10/+55°C
Relative Humidity: 20-75%

1.4. Project data

Testing Start Date: 2024-05-01
Testing End Date: 2024-05-16

1.5. Signature



Wang Meng
(Prepared this test report)

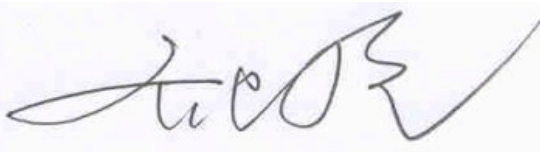

Qi Dianyuan
(Reviewed this test report)

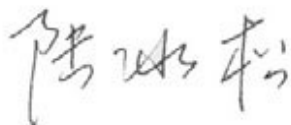

Lu Bingsong
Deputy Director of the laboratory
(Approved this test report)

2 Introduction

FCC regulation allows time averaged RF power to demonstrate compliance to RF exposure safety limits. Because RF exposure is correlated to transmission power (TX power), e.g., lower RF exposure is correlated to lower TX power, the TX power can be controlled to meet FCC RF exposure limits defined specific absorption rate (SAR) limit for transmit frequencies < 6GHz.

For SAR limit, the proposed Time-Averaged Specific Absorption Rate (TA-SAR) algorithm manages TX power to ensure that at all times the time-averaged RF exposure is compliant with the FCC SAR requirement. In the FCC regulation, the averaging window of SAR is 100 seconds for transmit frequencies less than 3GHz, 60 seconds for transmit frequencies between 3GHz and 6GHz.

This document describes the test plan, test procedures, measurement setup, and measurement results for the verification of the proposed TA-SAR algorithm being able to make RF exposure meet FCC requirement.

This purpose of the Part 2 report is to demonstrate the EUT complies with FCC exposure requirement under TX varying transmission scenarios, thereby validity of MediaTek TAS feature for FCC equipment authorization.

3 Operating Parameters for Algorithm Validation

Mediatek developed the TA-SAR algorithm to control instantaneous TX power for transmit frequencies less than 6GHz, respectively, so that the total time-averaged RF exposures are less than FCC requirement.

TA-SAR algorithm validation has been performed for 2G,3G,LTE,5G NR according to cases with different combinations of operating parameters listed in Table 3-1.

Table 3-1 TA-SAR operating parameters

Operating parameters	Description
P_{sub6_limit}	The time-averaged maximum power level limit for different band in sub6.
$P_{lowThresh_offset}$	To calculate $P_{lowthresh}$. ($P_{lowThresh} = P_{sub6_limit} - P_{lowThresh_offset}$)
$P_{ue_backoff_offset}$	To calculate $P_{ue_backoff}$. ($P_{ue_backoff} = P_{sub6_limit} - P_{ue_backoff_offset}$)
$P_{ue_max_cust_offset}$	To calculate $P_{ue_max_cust}$. P_{ue_max} is maximum TX power at which a UE can possibly transmit in sub6. ($P_{ue_max_cust} = \min(P_{ue_max}, P_{sub6_limit} + P_{ue_max_cust_offset})$)

4 Overview of TA-SAR

For the completeness of verifying that the proposed TA-SAR algorithm can realize FCC compliance regarding RF exposure, several test scenarios are constructed as below:

Scenario 1: test under different TA-SAR parameters to verify that the TA-SAR algorithm meets compliance requirements with different combinations of operating parameters.

Scenario 2: test under time-varying TX power to verify that the TA-SAR algorithm ensures SAR compliance through dynamic TX power.

Scenario 3: test under call drop and re-establishment conditions to ensure the TA-SAR algorithm control continuity and SAR compliance.

Scenario 4: test under RAT/band handover to ensure the TA-SAR algorithm control continuity and correctness.

Scenario 5: test under different ECIs (Exposure Condition Index) to ensure the TA-SAR algorithm control behaves as expected during ECI switching from one ECI to another. (e.g., head→ body worn)

Scenario 6: test under different transmission antennae to ensure the TA-SAR algorithm control works correctly during antenna switching from one antenna to another.

Scenario 7: test under different time windows to ensure the TA-SAR algorithm control functions correctly during time window switching from one time window setting to another.(e.g., time window 100s→60s)

Scenario 8: test under SAR exposure switching between two active radios (radio#1 dominant, radio#1+radio#2, and radio#2 dominant) to ensure the TA-SAR algorithm control continuity and SAR compliance.

5 TA-SAR Test Scenarios and Test Procedures

In order to demonstrate that TA-SAR algorithm performs as expected under various operating scenarios, Table 5-1 lists the test scenarios and expected test sequences to validate TA-SAR algorithm in these scenarios. The test sequences 0,1,2 are defined in section 5.1. The details of each test procedures via conducted power and SAR measurements are described in section 5.2~5.9 and section 5.10, respectively.

Table 5-1 Test scenario list of TA-SAR validation

Test scenario		Test sequence #	Description
1	Range of TA-SAR parameters	0	Adjust parameters
2	Time-varying TX power	1 and 2	Test under time-varying TX power
3	Call disconnection and re-establishment	0	Test call drop and re-establishment
4	Band/RAT handover	0	Test band/RAT change
5	ECI (Exposure Condition Index) change	0	Test under ECI transition (e.g., head→ body worn)
6	Antenna switching	0	Change antenna
7	Time window switching	0	Switch frequency bands with larger frequency separation (e.g., time window 100s→60s)
8	SAR exposure switching	0	Switch RATs when testing (e.g., LTE→NR)

5.1 Test Sequences for All Scenarios

Two test sequences having possibly time-varying TX power are predefined for TA-SAR validation:

- **Test sequence 0:** EUT's TX power is requested to be maximum.
- **Test sequence 1:** EUT's TX power is requested to be at power less than $P_{LowThresh}$ for 300s, then at maximum power for 200s, and finally at $P_{LowThresh} - 2\text{dB}$ for the remaining time.
- **Test sequence 2:** EUT's TX power to vary with time. This sequence is generated relative to measured P_{UE_max} , measured P_{sub6_limit} and calculated $P_{UE_backoff}$ (= measured P_{sub6_limit} in dBm - $P_{UE_backoff_offset}$ in dB) of EUT based on measured P_{sub6_limit} .
- Test sequence is generated based on below parameters of the EUT:
 - A. Measured maximum power (P_{UE_max})
 - B. Measured Tx power at SAR_design_limit (P_{sub6_limit})
 - C. Threshold of dynamic power reduction status determination: reserve hysteresis margin for instantaneous power ($P_{LowThresh}$)
 - D. SAR_time_window (FCC: 100s for $f < 3\text{GHz}$, 60s for $3\text{GHz} < f < 6\text{GHz}$)

The test sequence 0,1, and 2 are illustrated in Figure 5-1, Figure 5-2, and Figure 5-3, respectively. The waveforms of the three test sequences are listed in Table 5-2, Table 5-3, and Table 5-4.

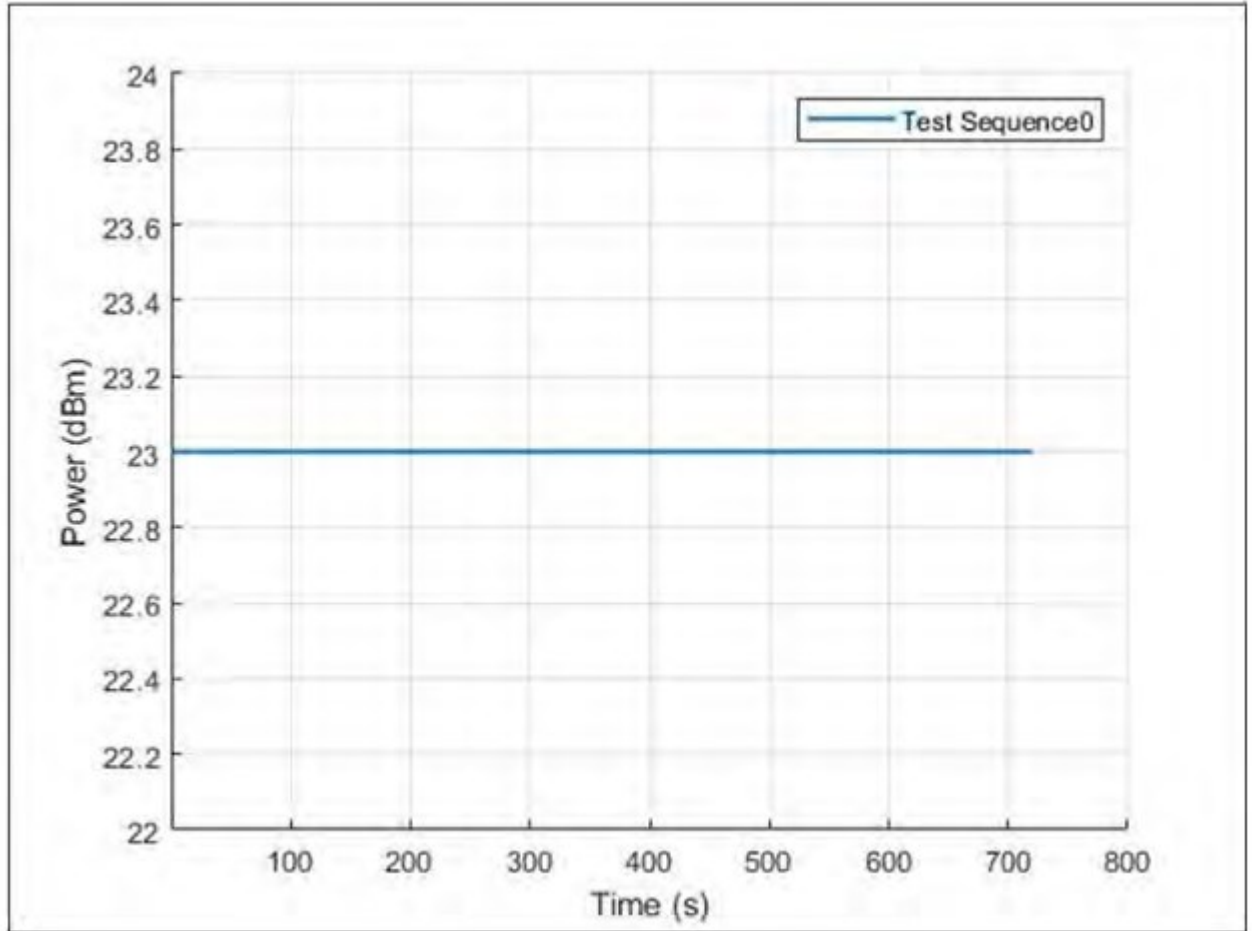

Figure 5-1 Test sequence 0

Table 5-2 Test sequence 1

Time	Duration	Power (dBm)	Note
720	720	23	P_{UE_max}

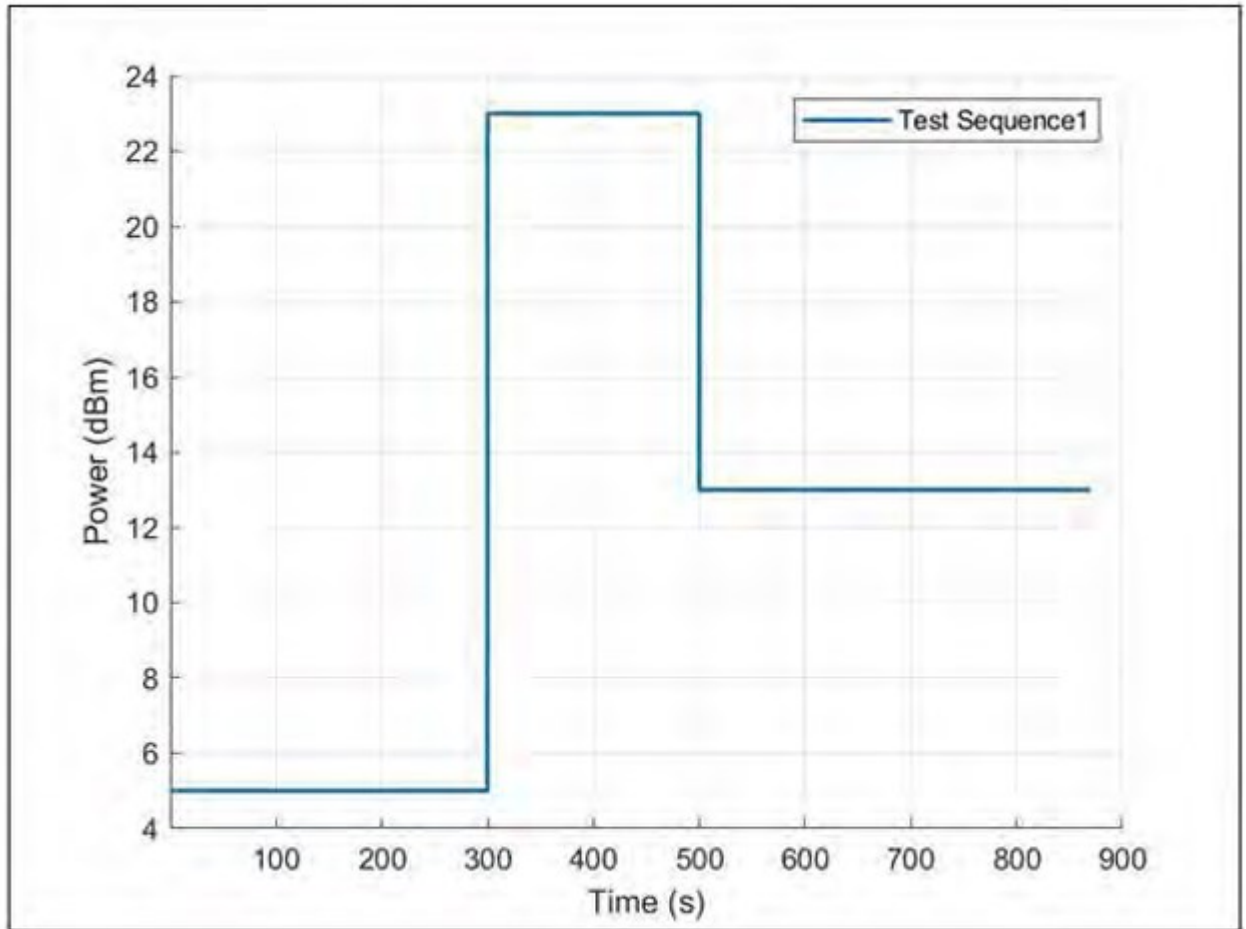

Figure 5-2 Test sequence 1

Table 5-3 Test sequence 1

Time	Duration	Power (dBm)	Note
300	300	5	$< P_{Lowthresh}$
500	200	23	P_{UE_max}
870	370	13	$P_{Lowthresh} - 2dB$

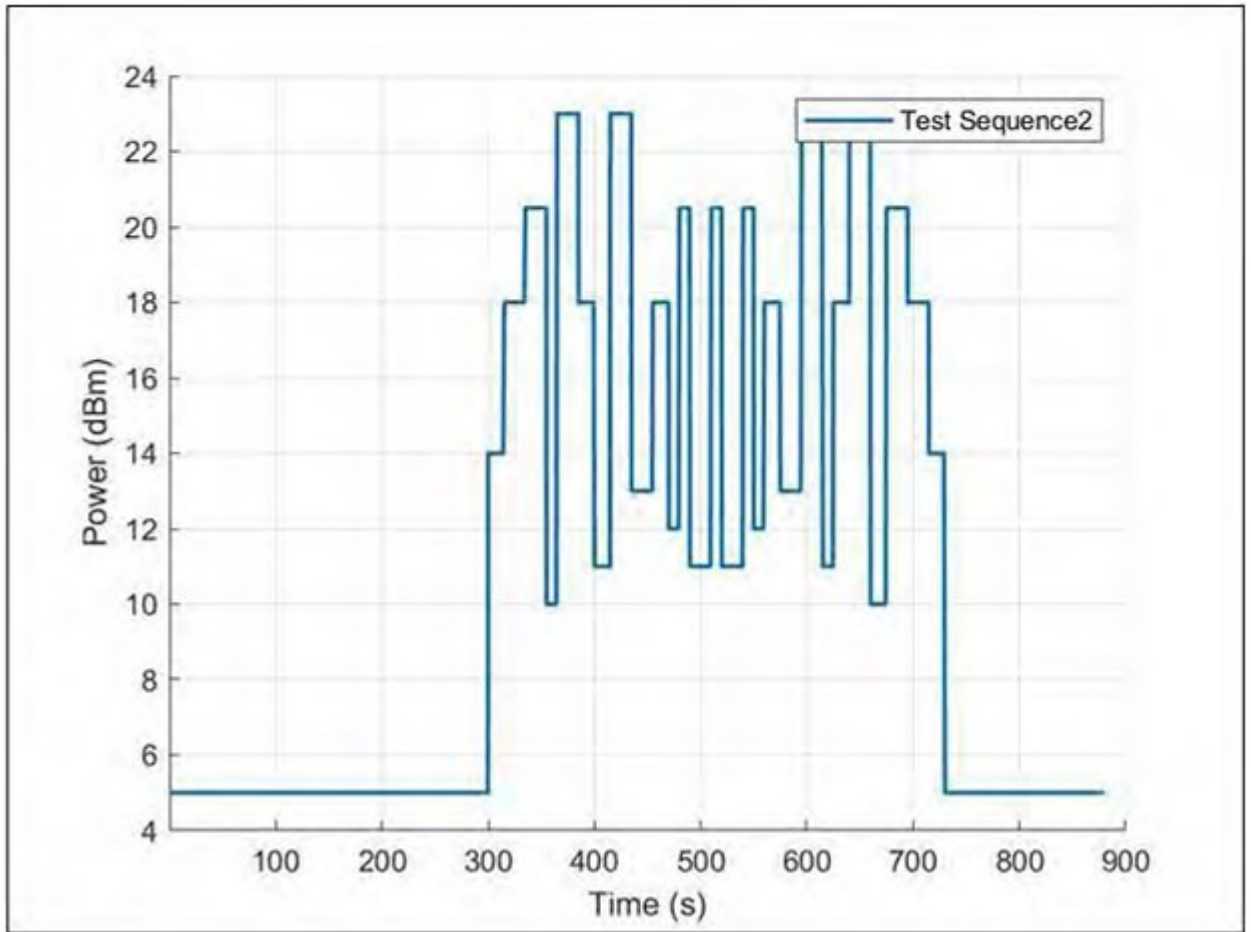

Figure 5-3 Test sequence 2

Table 5-4 Test sequence 2

Time	Duration	Power (dBm)	Note
300	300	5	$< P_{Lowthresh}$
315	15	14	$P_{sub6_limit} - 4dB$
335	20	18	P_{sub6_limit}
355	20	20.5	$(P_{sub6_limit} + P_{UE_max})/2$
365	10	10	$P_{sub6_limit} - 8dB$
385	20	23	P_{UE_max}
400	15	18	P_{sub6_limit}

415	15	11	$P_{sub6_limit} - 7dB$
435	20	23	P_{UE_max}
455	20	13	$P_{sub6_limit} - 5dB$
470	15	18	P_{sub6_limit}
480	10	12	$P_{sub6_limit} - 6dB$
490	10	20.5	$(P_{sub6_limit} + P_{UE_max})/2$
510	20	11	$P_{sub6_limit} - 7dB$
520	10	20.5	$(P_{sub6_limit} + P_{UE_max})/2$
540	20	11	$P_{sub6_limit} - 7dB$
550	10	20.5	$(P_{sub6_limit} + P_{UE_max})/2$
560	10	12	$P_{sub6_limit} - 6dB$
575	15	18	P_{sub6_limit}
595	20	13	$P_{sub6_limit} - 5dB$
615	20	23	P_{UE_max}
625	10	11	$P_{sub6_limit} - 7dB$
640	15	18	P_{sub6_limit}
660	20	23	P_{UE_max}
675	15	10	$P_{sub6_limit} - 8dB$
695	20	20.5	$(P_{sub6_limit} + P_{UE_max})/2$
715	20	18	P_{sub6_limit}
730	15	14	$P_{sub6_limit} - 4dB$
870	140	5	$< P_{Lowthresh}$

5.2 Test Configuration and Procedure for Scenario 1: Range of TA-SAR Parameters via Conducted Power Measurements

5.2.1 Configuration

This test is performed by changing the parameters ($P_{LowThresh_offset}$, $P_{UE_backoff_offset}$, $P_{UE_max_cust_offset}$) for the selected RAT (Radio Access Technologies) and band. Since Meditek's TA algorithm operation is independent of RATs/bands/channels, any one RAT can be selected for this test and the selected band of the RAT has the least P_{sub6_limit} . In principle, two sets of the parameters are determined for this test (if applicable). If the parameters of the EUT are fixed (without a support of dynamic change), only the set of the default parameters needs to be tested.

5.2.2 Procedure

TX power is measured, recorded, and processed by the following steps:

- Step 1~4: measure and record TX power versus time for test scenario 1

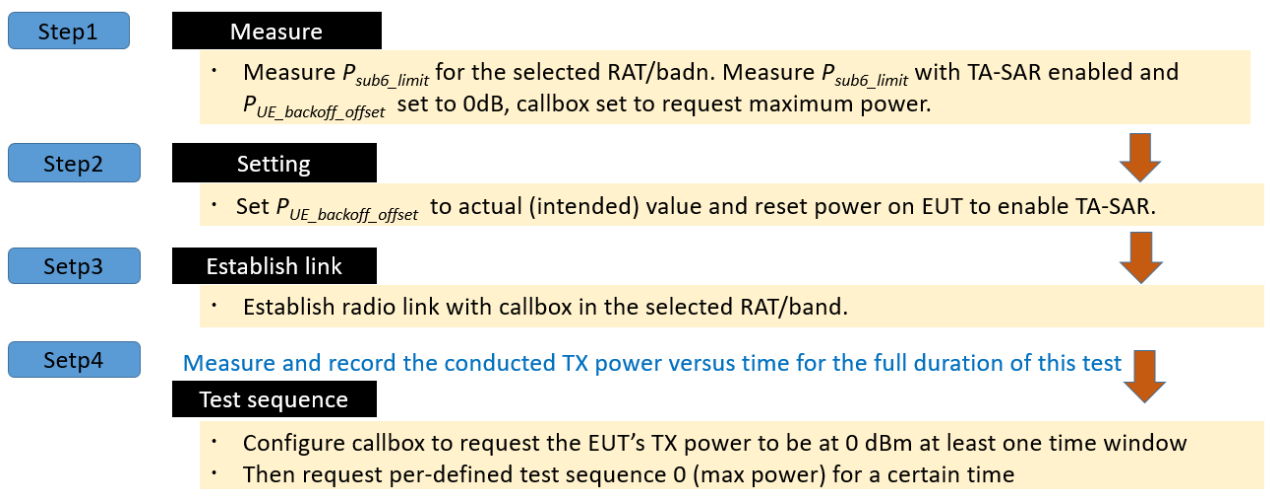

- Step 5: convert the measured conducted TX power into SAR

Convert the measured conducted TX power from step 4 into 1gSAR or 10gSAR value using the following equation. Perform the running time average to power and 1gSAR or 10gSAR to determine time-averaged value versus time as follows,

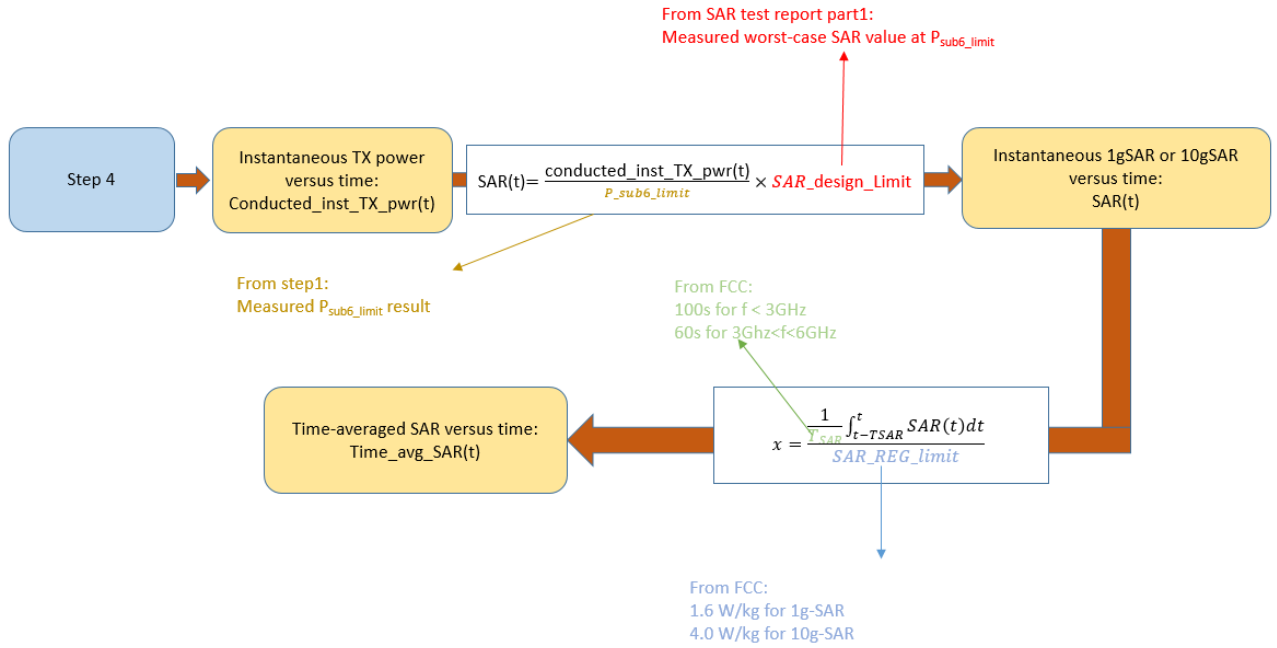

- Step 6: plot results
 - A. Make one power perspective plot containing
 1. Instantaneous TX power
 2. Requested power
 3. Calculated time-averaged power
 4. Calculated time-averaged power limits
 - B. Make one SAR perspective plot containing
 5. Calculated time-averaged 1gSAR or 10gSAR
 6. FCC limit of 1.6 W/kg (1gSAR) or 4.0 W/kg (10gSAR)

5.3 Test Configuration and Procedure for Scenario 2: Time-varying TX Power via Conducted Power Measurements

5.3.1 Configuration

Since Mediatek's TA-SAR feature operation is independent of bands and channels for a given RAT, selecting one band per RAT is sufficient to validate this feature. One band per RAT are proposed for this test. The criteria for band selection for each RAT is based on the P_{sub6_limit} values (corresponding to SAR_design_limit) and is described as below:

- Select two bands, among the ones whose P_{sub6_limit} values are below P_{UE_max} , which correspond to least and highest P_{sub6_limit} values respectively.
 - Only one band needs to be tested if all the bands have same P_{sub6_limit} .
 - Only one band needs to be tested if only the band has P_{sub6_limit} below P_{UE_max} .
 - If the same least P_{sub6_limit} applies to multiple bands, select the band with the highest measured 1gSAR at P_{sub6_limit} .
 - If P_{sub6_limit} values of all bands are all over P_{UE_max} (i.e., TA-SAR feature is not enabled), there is no need to test this RAT.

5.3.2 Procedure

TX power is measured, recorded, and processed by the following steps:

- Step 1~4: measure and record TX power versus time for test scenario 2

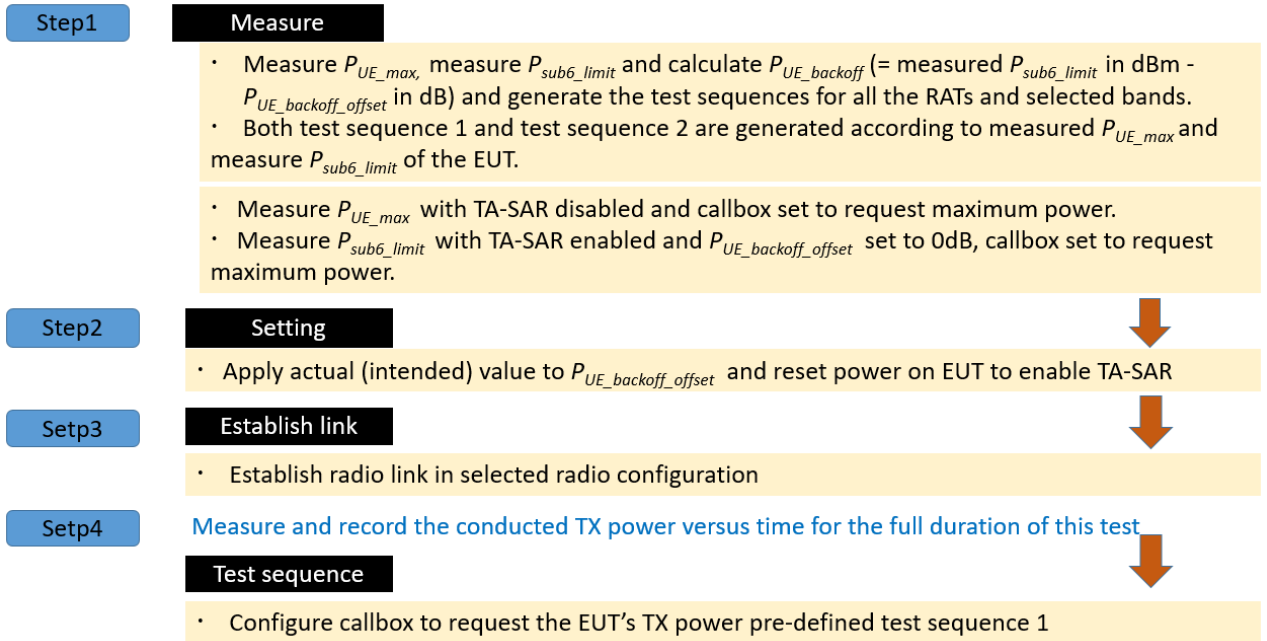

- Step 5: convert the measured conducted TX power into SAR

Convert the measured conducted TX power from step 4 into 1gSAR or 10gSAR value using the following equation. Perform the running time average to power and 1gSAR or 10gSAR to determine time-averaged value versus time as below:

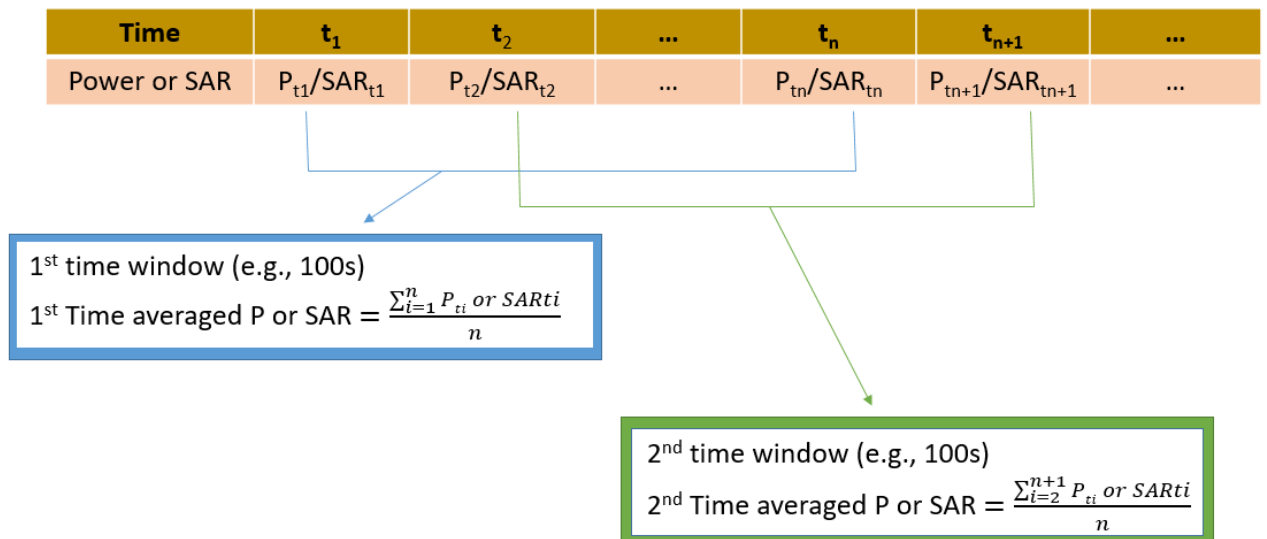

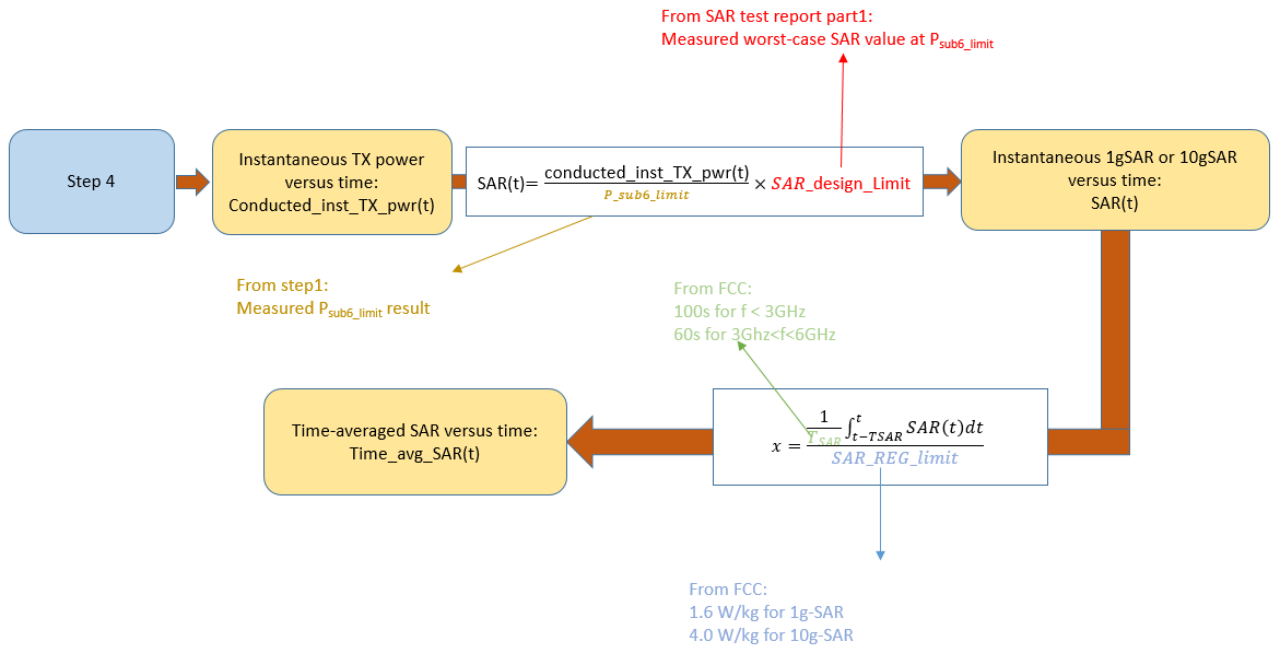

- Step 6: plot results
 - A. Make one power perspective plot containing
 1. Instantaneous TX power
 2. Requested power (test sequence1)
 3. Calculated time-averaged power
 4. Calculated time-averaged power limits
 - B. Make one SAR perspective plot containing
 1. Calculated time-averaged 1gSAR or 10gSAR
 2. FCC limit of 1.6 W/kg (1gSAR) or 4.0 W/kg (10gSAR)

- Step 7: repeat steps 2~6 for test sequence 2

Repeat steps 2 ~ 6 for pre-defined test sequence 2 and replace test sequence 1 in step 4 with test sequence 2.

- Step 8: repeat steps 2~7 for different bands

5.4 Test Configuration and Procedure for Scenario 3: Call Disconnection and Re-establishment via Conducted Power Measurements

5.4.1 Configuration

For call disconnection measurement, the criteria of selecting the test configuration is:

- Select the RAT/band with least P_{sub6_limit} among all supported RATs/bands.
- Select the RAT/band having the highest measured 1gSAR at P_{sub6_limit} if multiple RATs/bands having same least P_{sub6_limit} .
- Select the radio configuration in this RAT/band that corresponds to the highest measured 1gSAR at P_{sub6_limit} .

5.4.2 Procedure

TX power is measured, recorded, and processed by the following steps:

- Step 1~4: measure and record TX power versus time for test scenario 3

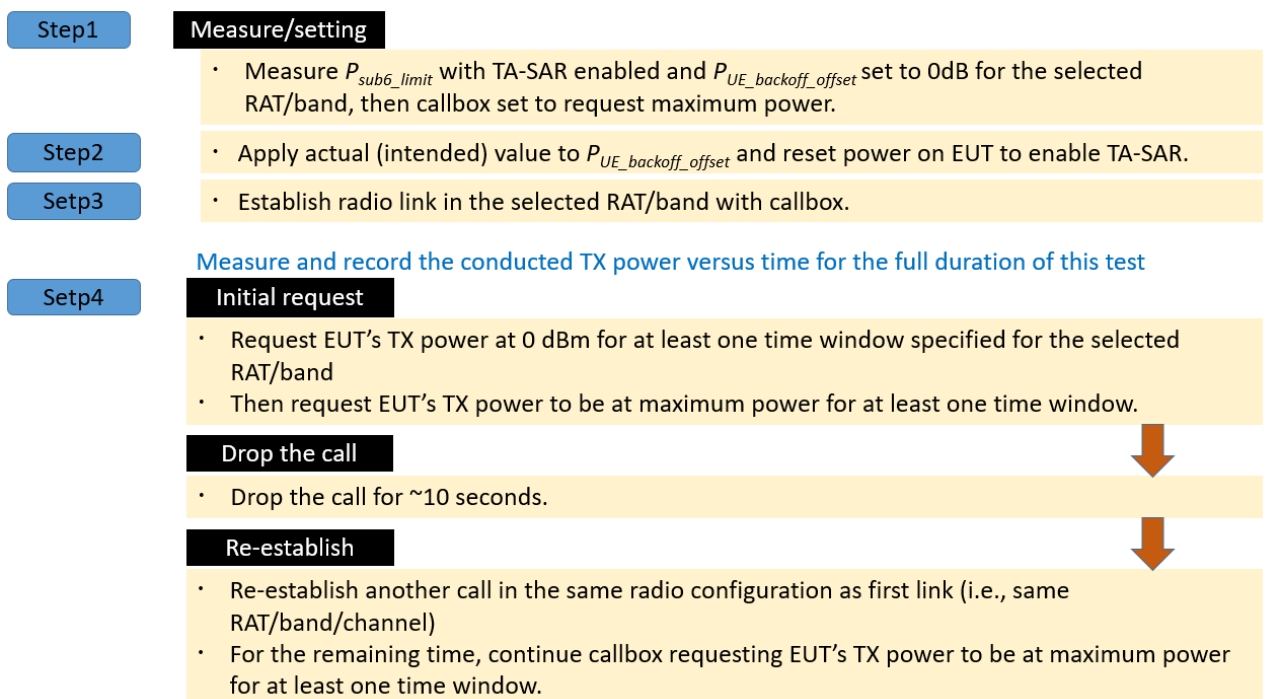

- Step 5: convert the measured conducted TX power into SAR

Convert the measured conducted TX power from step 4 into 1gSAR or 10gSAR value using the following equation. Perform the running time average to power and 1gSAR or 10gSAR to determine time-averaged value versus time as follows:

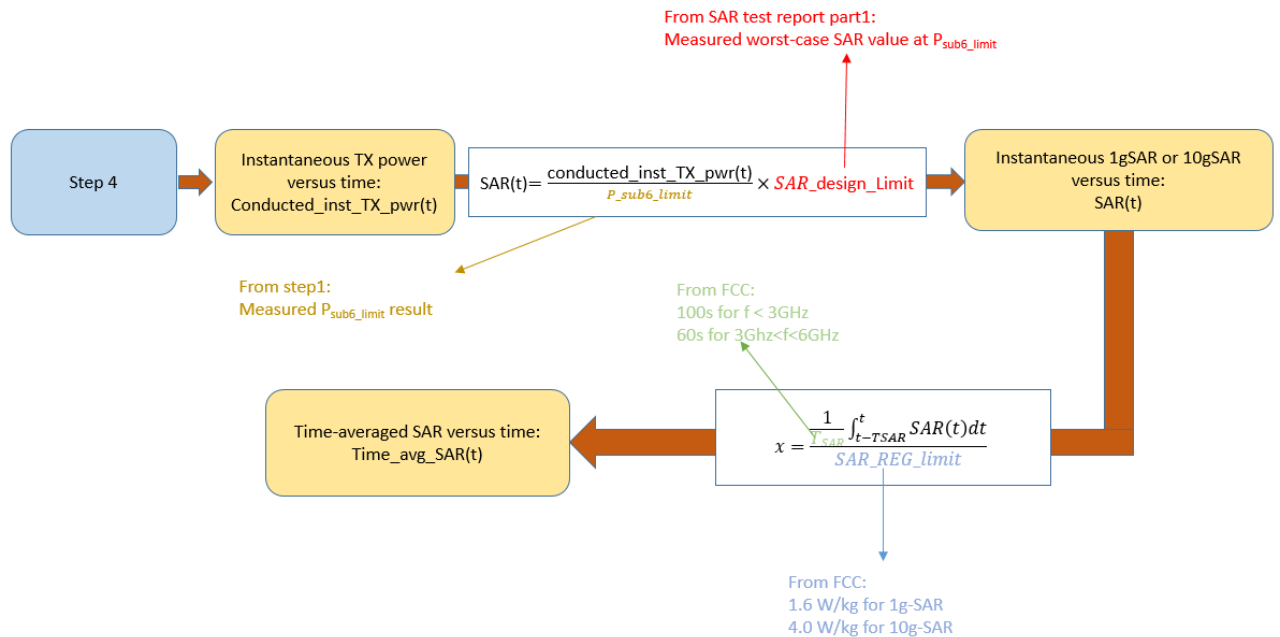

- Step 6: plot results
 - A. Make one power perspective plot containing
 1. Instantaneous TX power
 2. Requested power
 3. Calculated time-averaged power
 4. Calculated time-averaged power limits
 - B. Make one SAR perspective plot containing
 1. Calculated time-averaged 1gSAR or 10gSAR
 2. FCC limit of 1.6 W/kg (1gSAR) or 4.0 W/kg (10gSAR)

5.5 Test Configuration and Procedure for Scenario 4: Band Handover via Conducted Power Measurements

5.5.1 Configuration

For a given TX antenna, select a RAT/ band with the lowest P_{sub6_limit} and the other RAT/band with the highest P_{sub6_limit} . Both of them have P_{sub6_limit} values less than P_{UE_max} if possible.

- Select the RAT/band having the highest measured 1gSAR at P_{sub6_limit} if multiple RATs/bands have the same lowest P_{sub6_limit} .
- Select the RAT/band having the lowest measured 1gSAR at P_{sub6_limit} if multiple RATs/bands have the same highest P_{sub6_limit} .

5.5.2 Procedure

TX power is measured, recorded, and processed by the following steps:

- Step 1~4: measure and record TX power versus time for test scenario 4

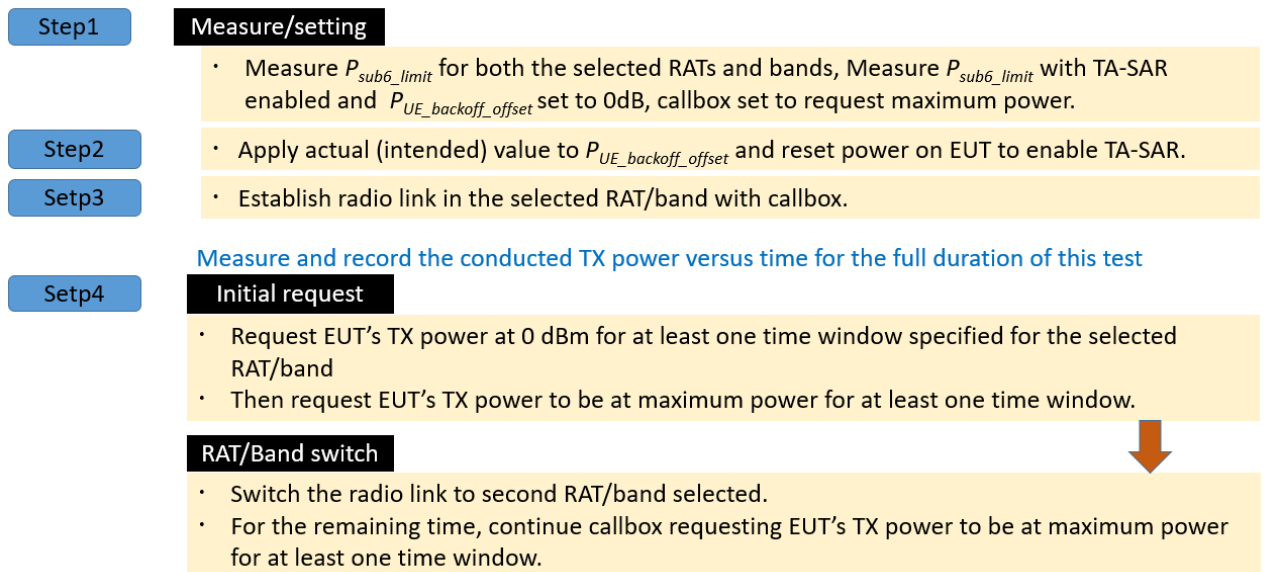

- Step 5: convert the measured conducted TX power into SAR

Convert the measured conducted TX power from step 4 into 1gSAR or 10gSAR value using the following equation. Perform the running time average to power and 1gSAR or 10gSAR to determine time-averaged value versus time as follows,

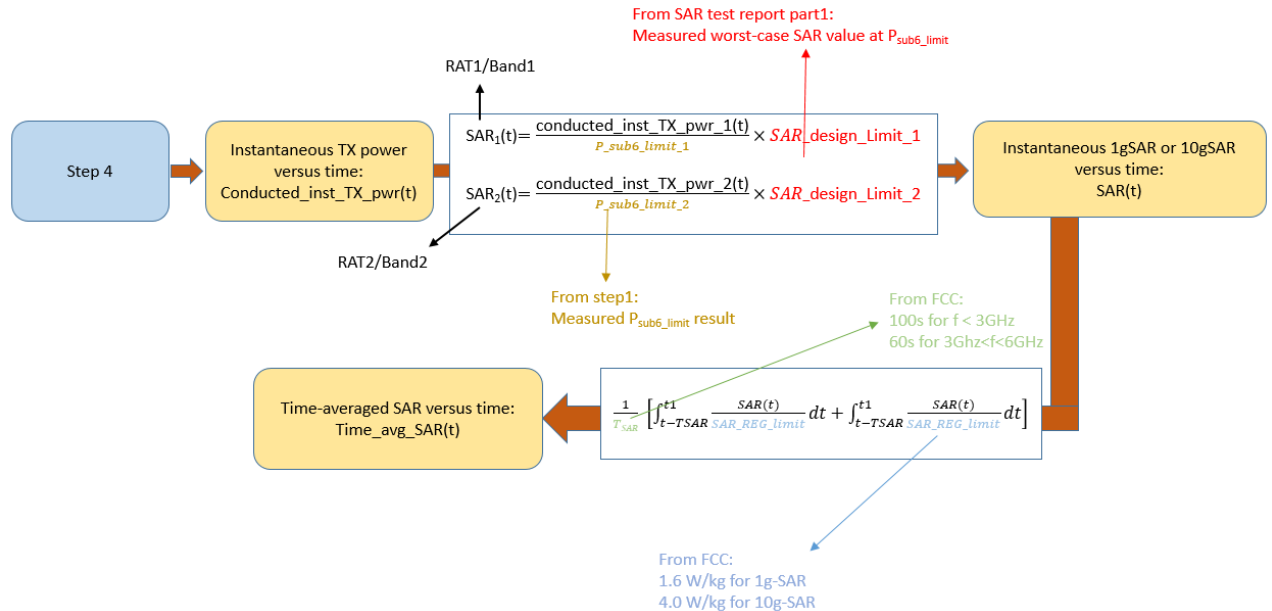

- Step 6: plot results

A. Make one power perspective plot containing

1. Instantaneous TX power
2. Requested power
3. Calculated time-averaged power
4. Calculated time-averaged power limits

B. Make one SAR perspective plot containing

1. Calculated time-averaged 1gSAR or 10gSAR
2. FCC limit of 1.6 W/kg (1gSAR) or 4.0 W/kg (10gSAR)
3. Normalized time-averaged 1gSAR/1.6 or 10gSAR /4.0

5.6 Test Configuration and Procedure for Scenario 5: Exposure Condition Index (ECI) Change via Conducted Power Measurements

5.6.1 Configuration

Select any one RAT/band, which has at least two ECIs whose P_{sub6_limit} values are different and are below P_{UE_max} .

5.6.2 Procedure

The test procedure is identical to section 5.5.2 except the following 2 changes:

1. Replace band switch operation with ECI switch.
2. In step 4, the second ECI switching is arranged after the first one lasts for at least one time window, i.e., switch the second ECI back to the first ECI, and then continue with callbox requesting EUT's TX power to be at maximum power for at least one time window.

It is noted that the following operations are done as well for this scenario:

- The correct power control is controlled by TA_SAR during ECI switches from one ECI to another.
- The validation criteria are, at all times, the time-averaged 1gSAR or 10gSAR versus time shall not exceed FCC limit of 1.6W/kg for 1gSAR or 4W/kg for 10gSAR.

5.7 Test Configuration and Procedure for Scenario 6: Antenna Switching via Conducted Power Measurements

5.7.1 Configuration

Among RATs/bands supporting TX antenna switches, select the RAT/band with the highest P_{sub6_limit} difference between a pair of supported TX antennas.

- Select the RAT/band having the highest measured 1gSAR at P_{sub6_limit} if multiple RATs/bands having the same P_{sub6_limit} difference between the supported TX antennas.
- Antenna selection order
 - Select the configuration with two antennas having P_{sub6_limit} values less than P_{UE_max} .
 - If the previous configuration does not exist, select the configuration with one antenna having P_{sub6_limit} value less than P_{UE_max} .
 - If the above two cannot be found, select one configuration with the two antennas having the least difference between their P_{sub6_limit} and P_{UE_max} (i.e., P_{sub6_limit} can be greater than P_{UE_max}).

5.7.2 Procedure

The test procedure is identical to section 5.5.2 except the following 2 changes:

1. Replace band switch operation with antenna switch.
2. In step 4, the second antenna switching is arranged after the first one lasts for at least one time window, i.e., switch the second antenna back to the first antenna, and then continue with callbox requesting EUT's TX power to be at maximum power for at least one time window.

It is noted that the following operations are done as well for this scenario:

- The correct power control is controlled by TA_SAR during antenna switches from one antenna to another.
- The validation criteria are, at all times, the time-averaged 1gSAR or 10gSAR versus time shall not exceed FCC limit of 1.6W/kg for 1gSAR or 4.0W/kg for 10gSAR.

5.8 Test Configuration and Procedure for Scenario 7: Time Window Switching via Conducted Power Measurements

5.8.1 Configuration

Select one RAT/band with 60-second time averaging window, and the other RAT/band with 100-second time averaging window. Both of them have P_{sub6_limit} values less than P_{UE_max} if possible.

- At least one of the selected RAT/band has its P_{sub6_limit} less than P_{UE_max} .

5.8.2 Procedure

TX power is measured, recorded, and processed by the following steps:

- Step 1~4: measure and record TX power versus time for test scenario 7

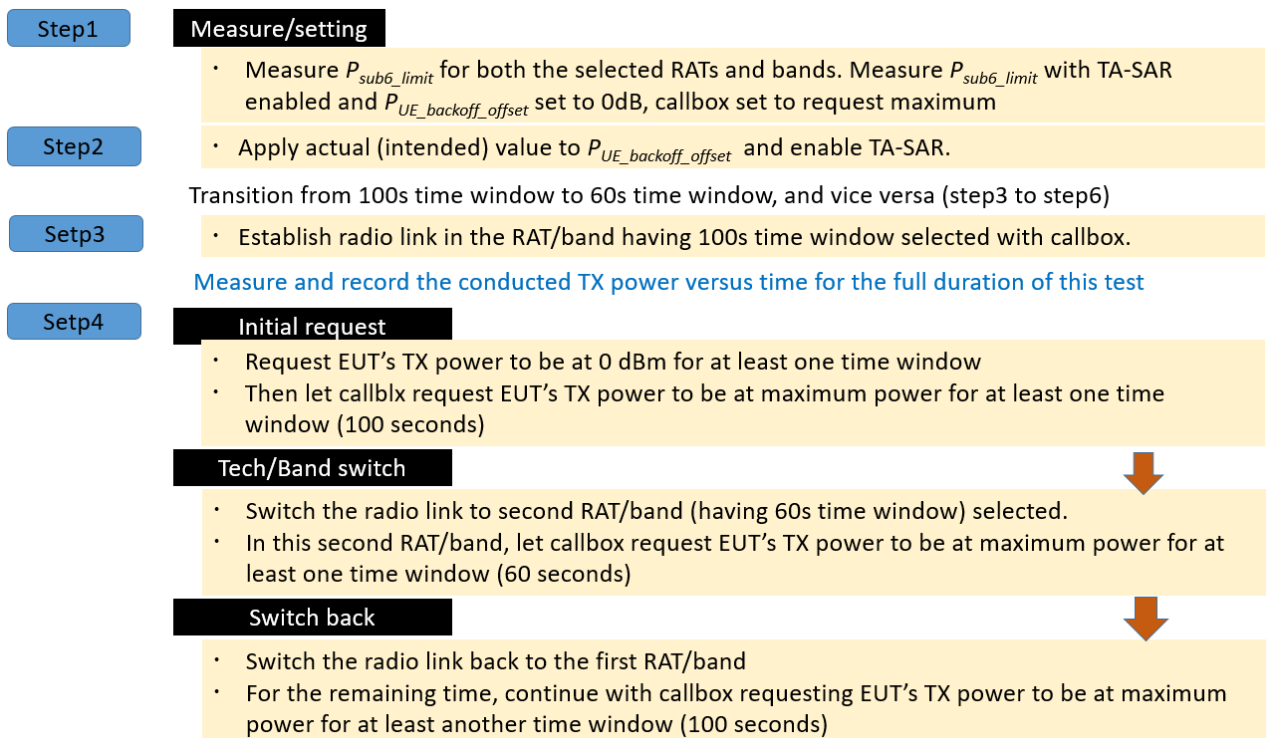

- Step 5: convert the measured conducted TX power into SAR

Convert the measured conducted TX power from step 4 into 1gSAR or 10gSAR value using the following equation. Perform the running time average to power and 1gSAR or 10gSAR to determine time-averaged value versus time as follows,

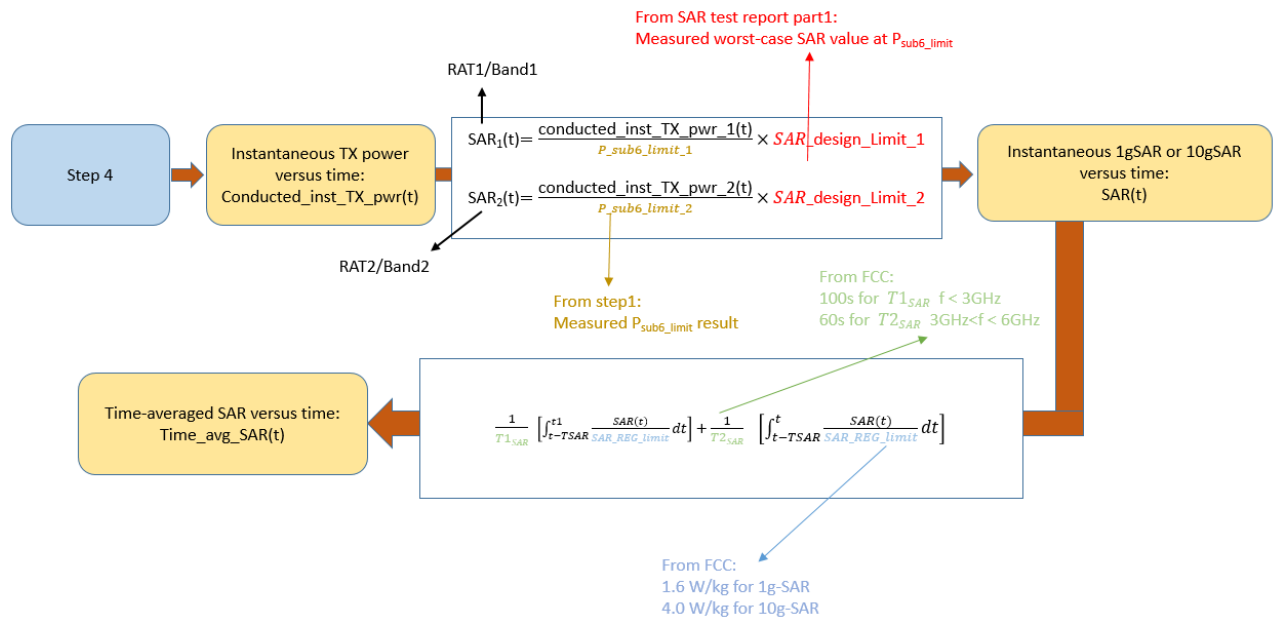

- Step 6: plot results

- A. Make one power perspective plot containing

1. Instantaneous TX power
2. Requested power
3. Calculated time-averaged power
4. Calculated time-averaged power limits

- B. Make one SAR perspective plot containing

1. Calculated time-averaged 1gSAR or 10gSAR
2. FCC limit of 1.6 W/kg (1gSAR) or 4.0 W/kg (10gSAR)
3. Normalized time-averaged 1gSAR/1.6 or 10gSAR /4.0

- Step 7 ~ 8: measure and record TX power versus time in another time window change

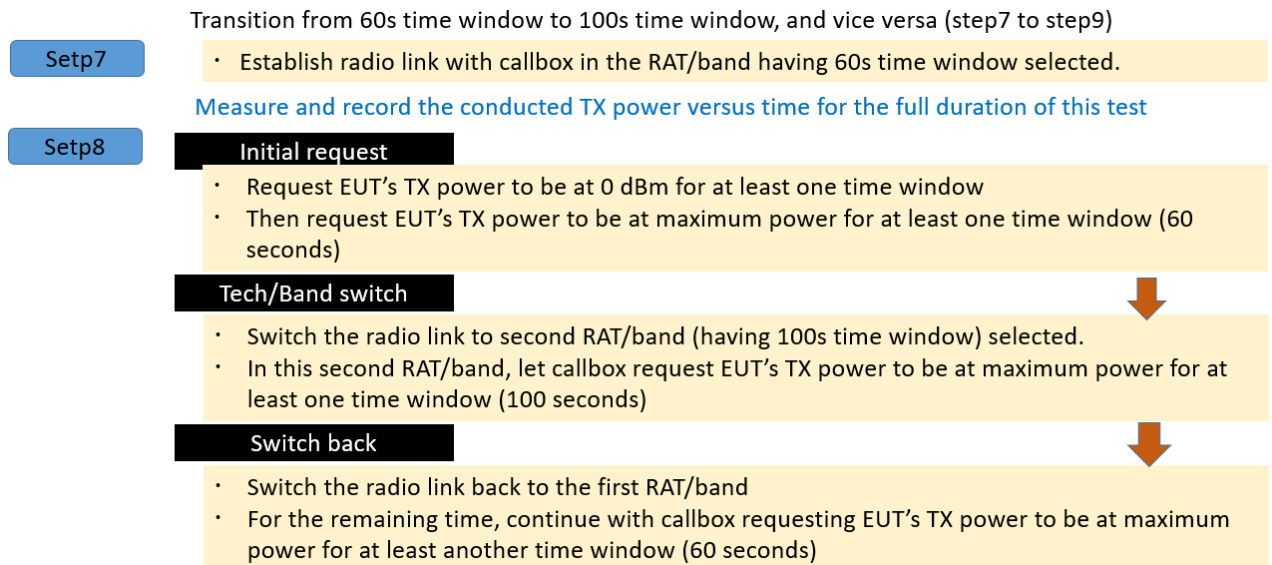

- Step 9: convert the measurement and plot results

Convert the measured conducted TX power from step 8 into 1gSAR or 10gSAR value using the equation in step 5.

Repeat step 6 to generate the plots.

5.9 Test Configuration and Procedure for Scenario 8: SAR Exposure Switching via Conducted Power Measurements

5.9.1 Configuration

If supported, SAR exposure switch with two active radios having the same and different time averaging windows should be covered in this test. Mediatek's TA algorithm operation is independent of the source of SAR exposure (e.g., LTE vs. NR FR1) and ensures total time-averaged RF exposure compliance for SAR exposure among the scenarios of radio 1 only, radio 1 + radio 2, and radio 2 only.

- Select any two <6GHz RATs/bands that the EUT supports for simultaneous transmission (e.g., LTE + NR FR1).
- The selection order among all supported simultaneous transmission configurations is
 - Select one configuration with P_{sub6_limit} values of radio1 and radio2 less than their corresponding P_{UE_max} , and their P_{sub6_limit} values are different if possible.
 - If the previous configuration does not exist, at least one radio has its P_{sub6_limit} less than P_{UE_max} .
 - If above two cannot be found, select one configuration that has P_{sub6_limit} of radio 1 and radio 2 with the least difference between P_{sub6_limit} and P_{UE_max} (i.e., P_{sub6_limit} can be greater than P_{UE_max})
- One test with two active radios in any two different time windows is sufficient to cover this scenario.
- One SAR switching is sufficient because the TA algorithm operation is the same.

5.9.2 Procedure

- Step 1~3: measure and record TX power versus time for test scenario 8
 1. Measure conducted TX power corresponding to radio1 P_{sub6_limit}
 - Establish device in call with the callbox for radio1 band.
 - Measure conducted TX power corresponding to radio1 P_{sub6_limit} with TA-SAR enabled and $P_{UE_backoff_offset}$ set to 0dB, callbox set to request maximum power.
 2. Measure conducted TX power corresponding to radio2 P_{sub6_limit}
 - Repeat above step to measure conducted TX power corresponding to radio2 P_{sub6_limit} .
 - If radio2 is dependent on radio1 (for example, non-standalone mode of NR FR1 requiring radio1 LTE as anchor), then establish radio1 + radio2 call with callbox, and request all down bits for radio1 LTE.
 - In this scenario, with callbox requesting maximum power from radio2 NR FR1, measured conducted TX power corresponds to radio2 P_{sub6_limit} (as radio1 LTE is at all-down bits).

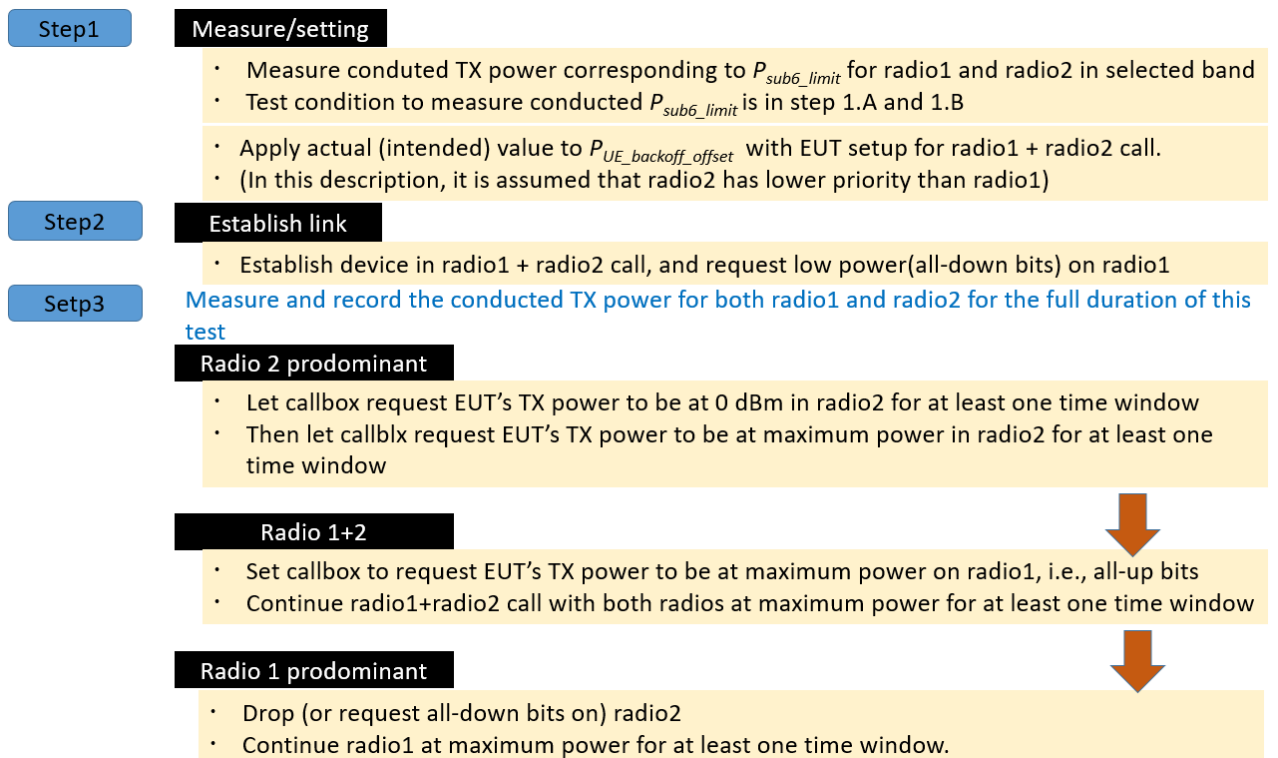

- Step 4: convert the measured conducted TX power into SAR

Convert the measured conducted TX power from step 3 into 1gSAR or 10gSAR value using the following equation. Perform the running time averaged to power and 1gSAR or 10gSAR to determine time-averaged value versus time as follows,

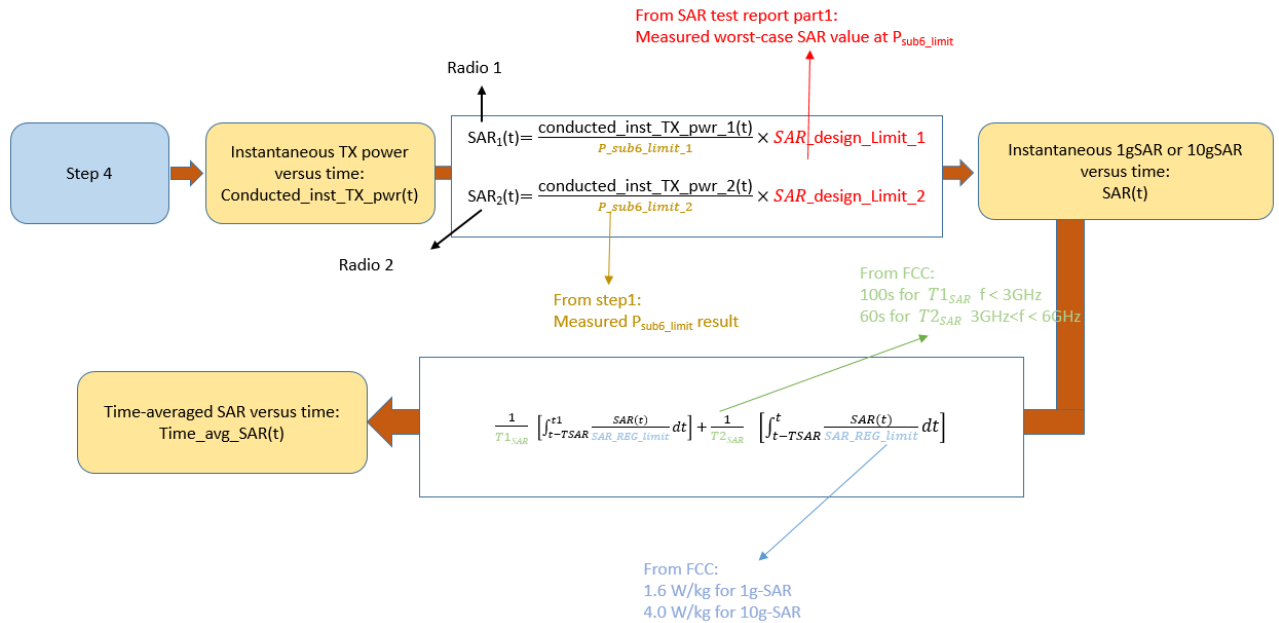

- Step 5: plot results

A. Make one power perspective plot containing

1. Instantaneous TX power
2. Requested power
3. Calculated time-averaged power
4. Calculated time-averaged power limits

B. Make one SAR perspective plot containing

1. Calculated time-averaged 10gSAR
2. FCC limit of 1.6 W/kg (1gSAR) or 4.0 W/kg (10gSAR)
3. Normalized time-averaged 1gSAR/1.6 or 10gSAR /4.0

5.10 Test Configuration and Procedure for Scenario 2: Time-varying TX Power via SAR Measurements

5.10.1 Configuration

Section 5.2 to 5.9 focus on Mediatek's TA feature compliance validation via conducted TX power measurements. This section further provides a SAR measurement procedure for time-varying TX power scenario described in section 5.3. Hence, this section follows the test configuration of section 5.3, and uses test sequences 1 and 2 defined in section 5.1.

5.10.2 Procedure

SAR is measured and recorded by the following steps:

- Step 1~4: measure and record SAR time

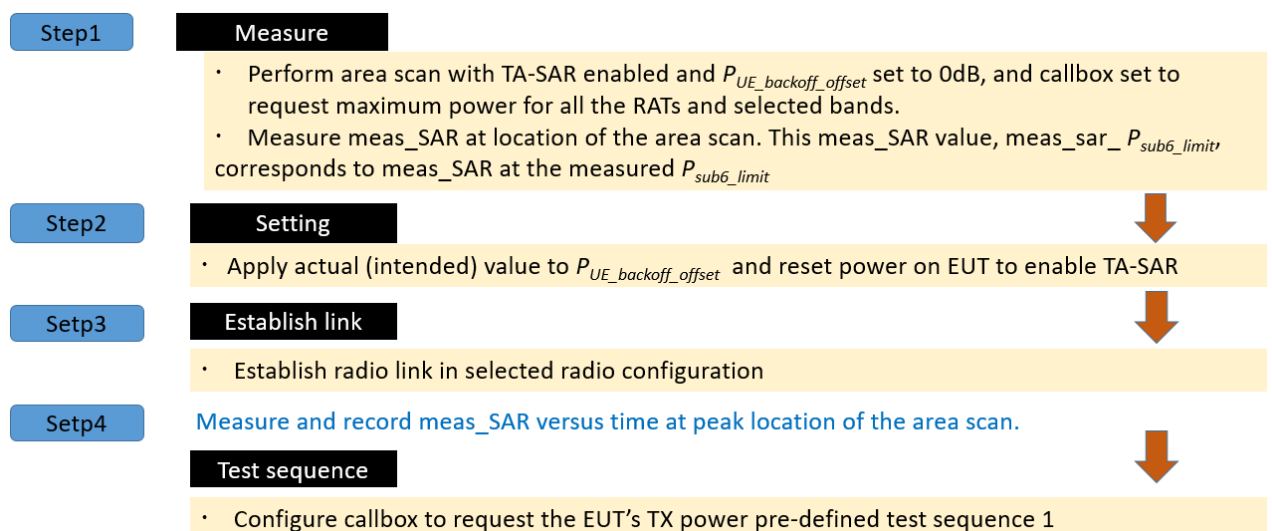

- Step 5: convert the measured SAR into time-averaged SAR

Convert the instantaneous measured SAR from step 4 into 1gSAR or 10gSAR value. Perform the running time average to 1gSAR or 10gSAR to determine time-averaged value versus time as follows,

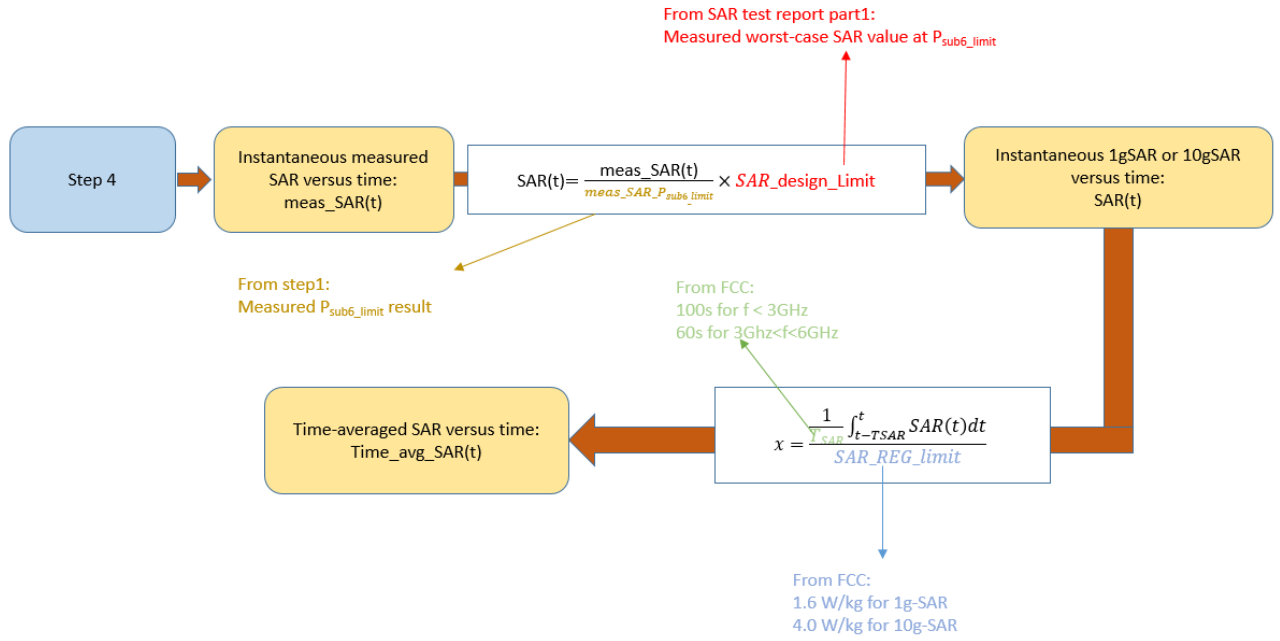

where, $meas_SAR_P_{sub6_limit}$ is the value determined in step 1, and $meas_SAR(t)$ is the instantaneous measured SAR measured in step 4.

- Step 6: plot results
 - A. Calculated time-averaged 1gSAR or 10gSAR
 - B. FCC limit of 1.6 W/kg (1gSAR) or 4.0 W/kg (10gSAR)

- Step 7: repeat steps 2~6 for pre-defined test sequence 2

Repeat steps 2 ~ 6 for pre-defined test sequence 2 and replace test sequence 1 in step 4 with test sequence 2.

- Step 8: repeat steps 2~7 for selected bands

The time-averaged SAR versus time shall not exceed FCC limit at all times.

6 TA-SAR Validation via Conducted Power Measurements

6.1 Measurement Setup

6.1.1 Test Bench Introduction

All of the test cases defined in this chapter are conducted by using the phone device, whose antenna placement for each RAT is illustrated in Figure 6-1.

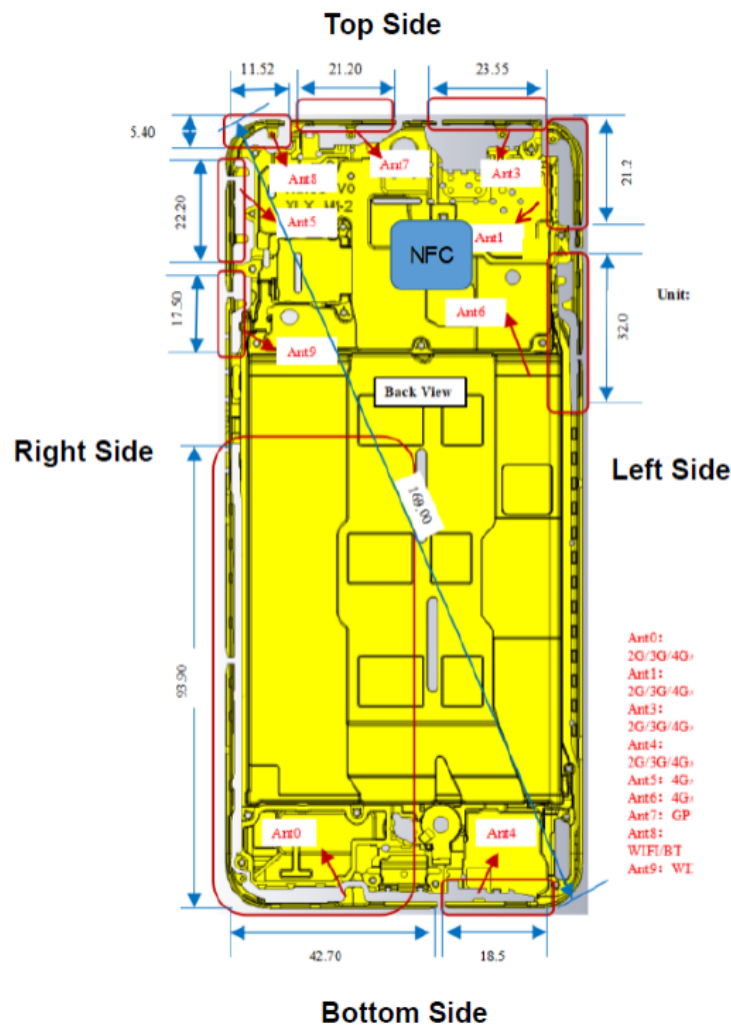

Figure 6-1 Antenna placement of the phone

The call boxes Keysight UXM (supporting sub6 NR and LTE) and Rohde & Schwarz CMW500 (supporting LTE, WCDMA and 2G) are used to validate the proposed TA-SAR mechanism. Figure 6-2 shows the block diagram of the measurement bench, which supports the following test scenarios.

- Test scenario 1: range of TA-SAR parameters
- Test scenario 2: time-varying TX power
- Test scenario 3: call disconnection and re-establishment
- Test scenario 5: ECI change

For these measurements, RF ports of the call box is connected to the EUT's antenna port, and the call box establishes a connection link through the test script console tool and the power meter measures the conducted output power of the EUT. The pictures of Figure 6-2 are relegated in Figures A-1 and A-2 in Appendix A.

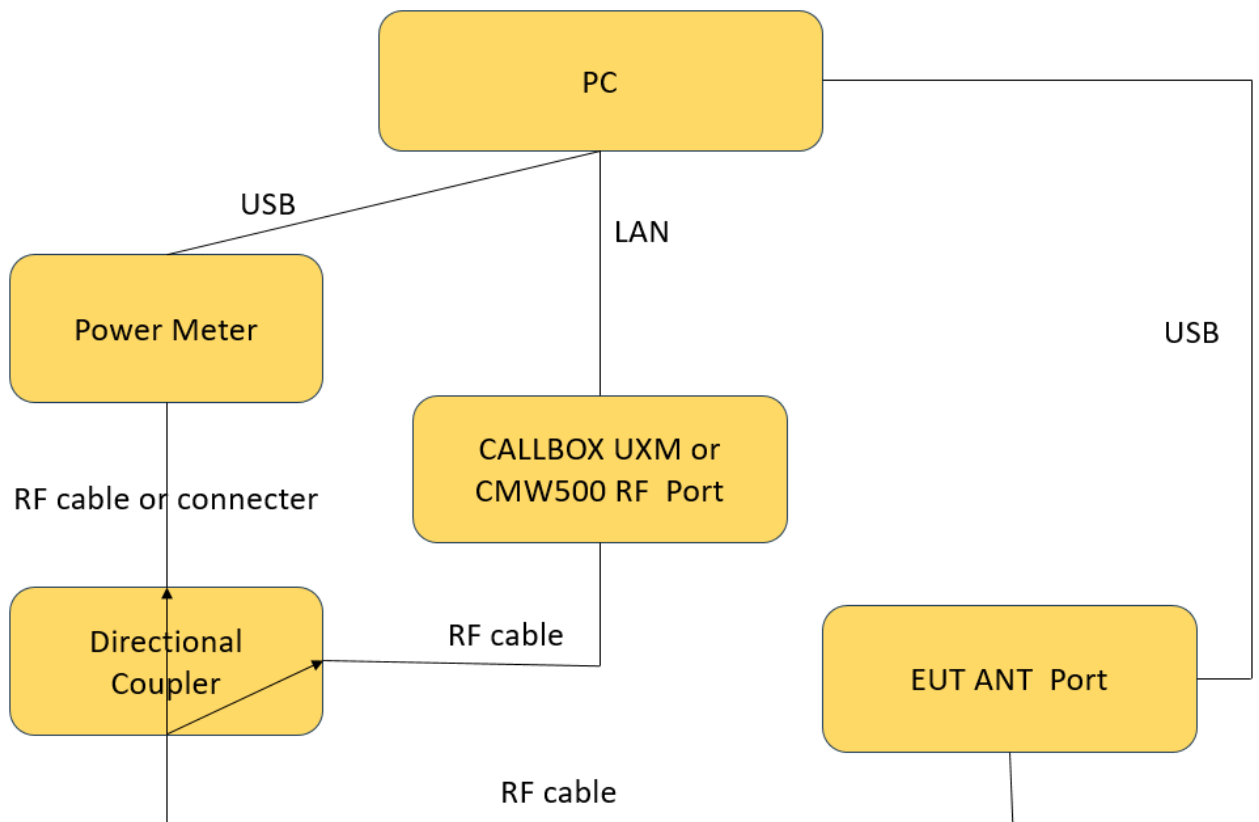

Figure 6-2 TA-SAR conductive power test setup block diagram for scenarios 1/2/3/5

Figure 6-3 shows the block diagram of the measurement bench, which support test scenario 4 (band handover) and scenario 7 (time window switching). For these measurements, the RF port of the call box is connected with a 1-to-2 power divider, which allows the call box to transmit/receive signals from the two different system configurations set in these two test scenarios. Figure 6-4 shows the setup, which is highly similar to Figure 6-3, to support test scenario 6 (antenna switching); as seen in the figure, two EUT's antenna ports are individually connected with a RF cable. The pictures for these two setups are shown in Figures A-3 and A-4 in Appendix A.

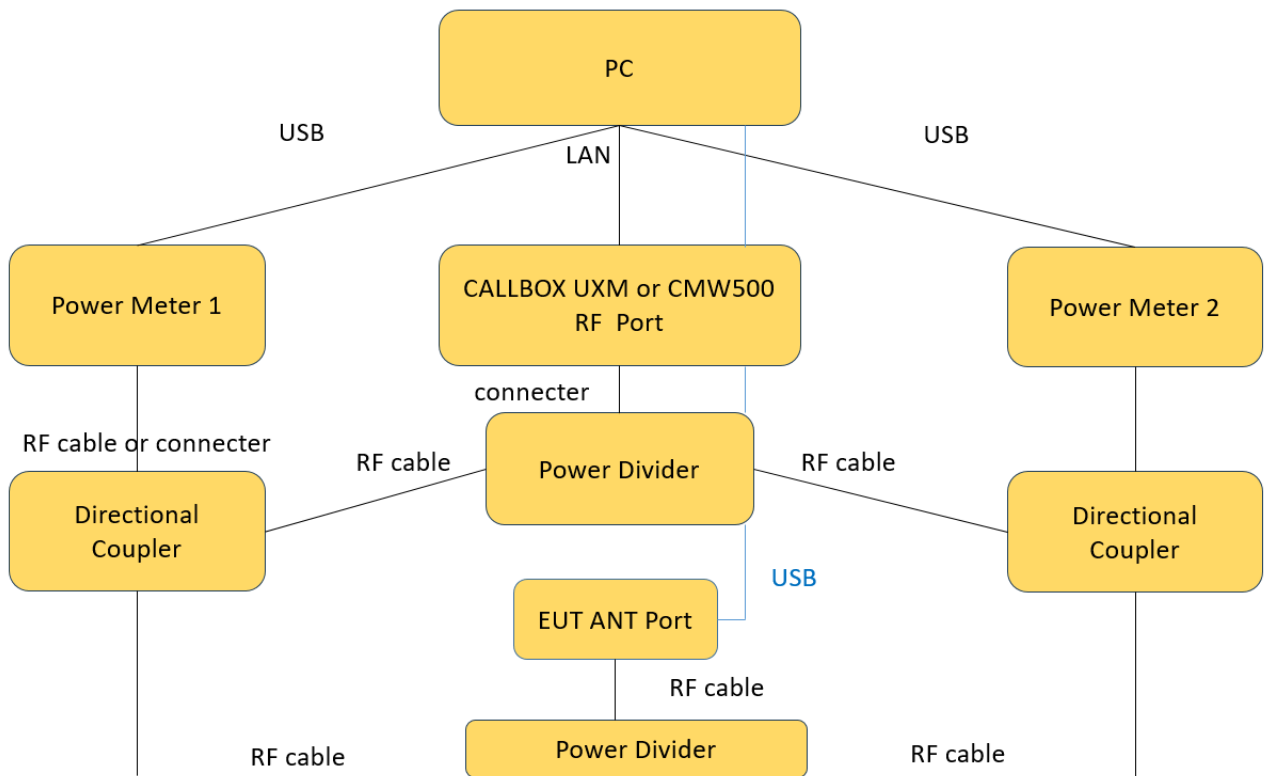

Figure 6-3 TA-SAR conductive power test setup block diagram for scenarios 4 and 7

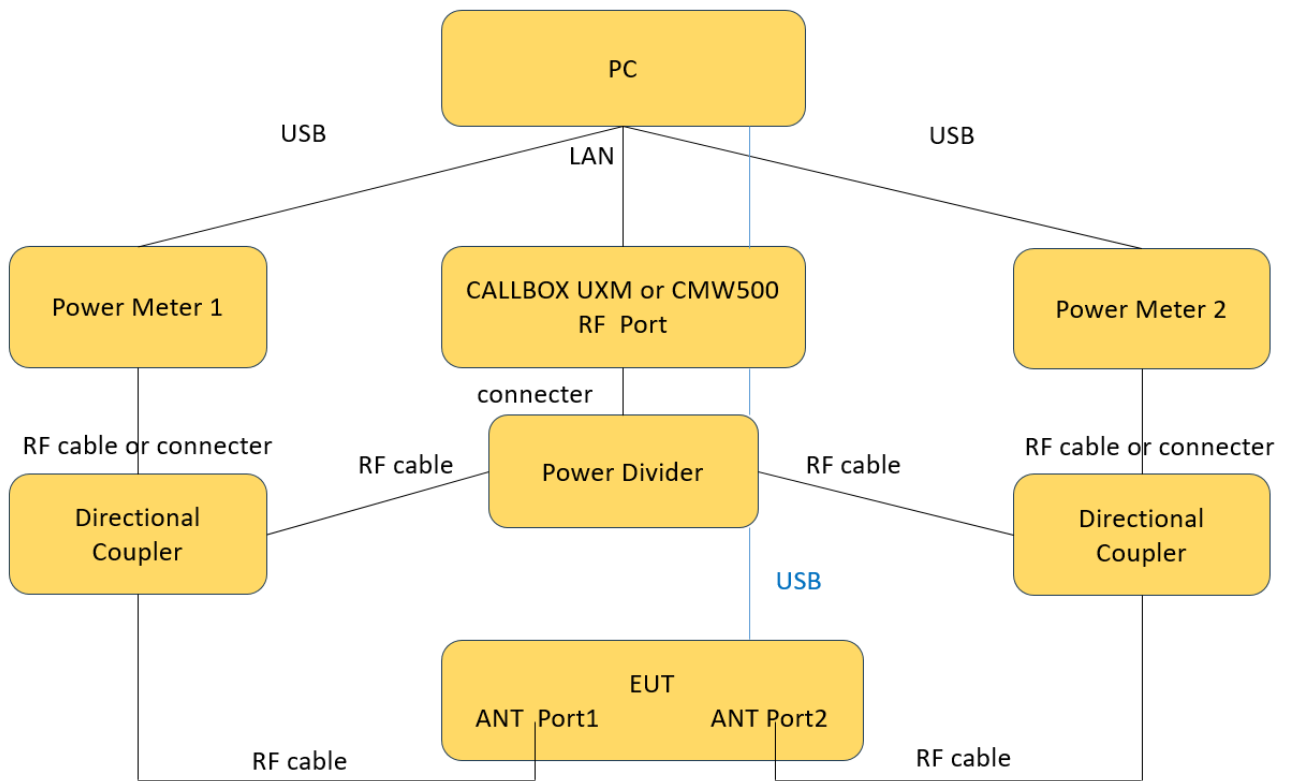

Figure 6-4 TA-SAR conductive power test setup block diagram for scenarios 6

Figure 6-5 shows the setup for test scenario 4 (RAT handover) and scenario 8 (SAR exposure switching). Since two RATs need to be controlled in these two scenarios, RF port of RAT #1 and RF port of RAT #2 of the call box are individually connected to an antenna port of the EUT through a directional coupler. It is noted that each of the two RATs individually transmit signals through one antenna port. The antenna port assignment of each RAT for these two scenarios is described in Figure 6-1. The pictures of Figure 6-5 are shown in Figures A-5 and A-6 in Appendix A.

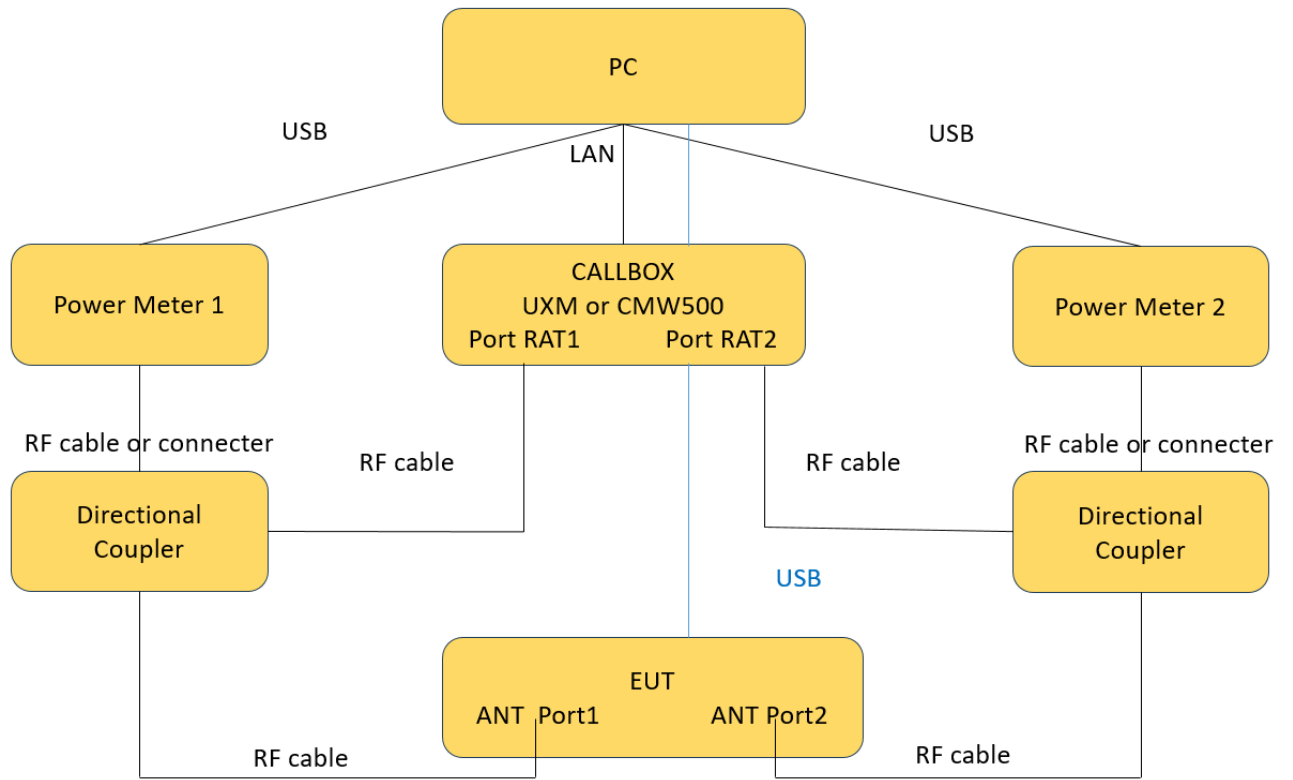

Figure 6-5 TA-SAR conductive power test setup block diagram for scenarios 4/8

6.1.2 Sub NR/LTE/3G/2G Power Limit Table and Test Configurations

For the supported bands/channels/antennas of each technology, the measured power limit (P_{sub6_limit}), corresponding to SAR_design_limit, is listed in the Table 6-1. The SAR_design_limit is determined by taking device uncertainty into consideration. Please note that for TDD bands with TX duty cycles less than or equal to 100%, the measured power limit corresponds to the burst averaged power level which does not account for TX duty cycle.

Table 6-1 Summary table of power limit (P_{sub6_limit}) for all supported RAT

Band	Antenna	Duty Cycle	Standalone Body		Standalone Head		Simultaneous transmission Body		Simultaneous transmission Head		Pmax*
			DS1	DS2	DS1	DS2	DS1	DS2	DS1	DS2	
GSM850	0	12.50%	32.7	32.7	32.7	32.7	32.7	32.7	32.7	32.7	32.7
	1		31.7	31.7	31.7	31.7	31.7	31.7	31.7	31.7	
GSM900	0		32.5	32.5	32.5	32.5	32.5	32.5	32.5	32.5	
	1		31.5	31.5	31.5	31.5	31.5	31.5	31.5	31.5	
GSM1900	3		29.3	26.3	29.3	25.3	29.3	25.3	29.3	25.3	
	4		29.7	29.7	29.7	29.7	29.7	29.7	29.7	29.7	
WCDMA Band 2	3	100%	22.4	18.4	19.9	17.4	19.9	17.4	19.9	17.4	
	4		21.9	23.4	19.4	23.4	19.4	23.4	19.4	23.4	
WCDMA Band 4	3		22.1	17.1	20.1	16.1	20.1	16.1	20.1	16.1	
	4		20	24	17.5	20	17.5	20	17.5	20	
WCDMA Band 5	0		24	24	24	24	24	24	24	24	
	1		23	23	23	23	23	23	23	23	
WCDMA Band 8	0		24	24	24	24	24	24	24	24	
	1		23	23	23	22.5	23	22.5	23	22.5	
LTE Band2	3		21.6	18.1	19.6	17.1	19.6	17.1	19.6	17.1	
	4		21.5	23	19	23	19	23	19	23	
	6		21.6	20.6	21.6	19.6	21.6	19.6	21.6	19.6	
LTE Band4	3		22.3	17.3	20.3	16.3	20.3	16.3	20.3	16.3	
	4		21.7	24.2	19.2	24.2	19.2	24.2	19.2	24.2	
	6		21.8	20.3	19.3	19.3	19.3	19.3	19.3	19.3	
LTE Band5	0	24.2	24.2	24.2	24.2	24.2	24.2	24.2	24.2		
	1	23.2	23.2	23.2	23.2	23.2	23.2	23.2	23.2		
LTE Band7	3	20.3	15.3	17.8	15.3	17.8	15.3	17.8	15.3		
	4	20.2	24.2	17.7	24.2	17.7	24.2	17.7	24.2		
	6	22.8	21.3	22.8	20.8	22.8	20.8	22.8	20.8		
LTE Band8	0	24.2	24.2	24.2	24.2	24.2	24.2	24.2	24.2		
	1	23.2	23.2	23.2	23.2	23.2	23.2	23.2	23.2		
LTE Band12	0	24.2	24.2	24.2	24.2	24.2	24.2	24.2	24.2		
	1	23.2	23.2	23.2	23.2	23.2	23.2	23.2	23.2		
LTE Band13	0	23	23	23	23	23	23	23	23		
	1	22	22	22	22	22	22	22	22		
LTE Band17	0	24.2	24.2	24.2	24.2	24.2	24.2	24.2	24.2		
	1	23.2	23.2	23.2	23.2	23.2	23.2	23.2	23.2		
LTE Band26	0	24.2	24.2	24.2	24.2	24.2	24.2	24.2	24.2		
	1	23.2	23.2	23.2	23.2	23.2	23.2	23.2	23.2		
LTE Band28	0	24.2	24.2	24.2	24.2	24.2	24.2	24.2	24.2		
	1	23.2	23.2	23.2	23.2	23.2	23.2	23.2	23.2		
LTE Band38	3	22.3	17.8	19.8	17.3	19.8	17.3	19.8	17.3		
	4	21.2	24.2	19.2	24.2	19.2	24.2	19.2	24.2		
	6	22.8	21.8	22.8	21.8	22.8	21.8	22.8	21.8		
LTE Band41 PC2	3	24.6	18.1	21.6	17.6	21.6	17.6	21.6	17.6		
	4	22	25	19.5	25	19.5	25	19.5	25		
	6	23.5	23.5	23.5	23.5	23.5	23.5	23.5	23.5		
LTE Band41 PC3	3	22.1	17.6	21.1	17.1	21.1	17.1	21.1	17.1		
	4	21.5	22.5	19	22.5	19	22.5	19	22.5		
	6	21	21	21	21	21	21	21	21		
LTE Band66	3	21.8	17.3	19.8	16.3	19.8	16.3	19.8	16.3		
	4	20.2	24.2	18.2	24.2	18.2	24.2	18.2	24.2		
	6	21.8	20.3	19.3	19.3	19.3	19.3	19.3	19.3		
N2	3	20.6	17.6	18.1	16.6	18.1	16.6	18.1	16.6		
	4	20	23	18	23	18	23	18	23		
	6	21.6	20.1	21.6	19.1	21.6	19.1	21.6	19.1		
N5	0	24	24	24	24	24	24	24	24		
	1	23.5	23.5	23.5	23.5	23.5	23.5	23.5	23.5		
N7	3	19.8	15.3	17.3	14.3	17.3	14.3	17.3	14.3		
	4	20	24	17.5	24	17.5	24	17.5	24		
	6	22.3	22.8	22.3	21.3	22.3	21.3	22.3	21.3		
N12	0	24	24	24	24	24	24	24	24		
	1	23.5	23.5	23.5	23.5	23.5	23.5	23.5	23.5		
N26	0	24	24	24	24	24	24	24	24		
	1	23	23	23	23	23	23	23	23		
N38	3	19.5	16.5	17	14.5	17	14.5	17	14.5		
	4	18.5	24	16	24	16	24	16	24		
	6	20.6	21.6	18.1	20.6	18.1	20.6	18.1	20.6		
N41 PC3	3	19.5	15.5	17	14.5	17	14.5	17	14.5		
	4	18	24	16	24	16	24	16	24		
	6	20.5	21	18	20	18	20	18	20		
N66	3	22.1	17.1	20.1	17.1	20.1	17.1	20.1	17.1		
	4	21.5	24	19.5	24	19.5	24	19.5	24		
	6	21.6	20.1	21.6	19.1	21.6	19.1	21.6	19.1		

Table 6-2 summarizes the test configurations of all RATs, and the corresponding worst-case measured SAR for each RAT under the power limit.

Table 6-2 Test configurations of radio technologies and worst-case measured SAR

Test case	Test Scenario	Tech	Band	ANT	ECI	Channel	Frequency	Modulation	RB	BW (MHz)	SAR Exposure Scenario	Position	Worst-case Measured SAR at P_sub0_limit W/gk
1	Range of TA-SAR parameters	WCDMA	4	3	4	1413	1732.6	RMC	/	/	head	Right Cheek	0.571
2.1 ~ 2.2	Time-varying TX power	Sub6 NR	38	6	2	520000	2600	DFT-OFDM QPSK	50@25	40M	head	Right Cheek	0.870
2.3 ~ 2.4		Sub6 NR	7	3	4	510000	2550	DFT-OFDM QPSK	106@54	40M	head	Right Cheek	0.740
2.5 ~ 2.6		LTE	4	3	1	20300	1745	QPSK	100@0	20M	Body 10mm	Top	0.731
2.7 ~ 2.8		LTE	7	3	2	21350	2560	QPSK	1@50	20M	head	Right Cheek	0.627
2.9 ~ 2.10		WCDMA	2	3	1	9538	1907.6	RMC	/	/	Body 10mm	Top	0.656
2.11 ~ 2.12		WCDMA	4	3	4	1413	1732.6	RMC	/	/	head	Right Cheek	0.571
2.13 ~ 2.14		GSM	1900	3	2	810	1908.8	1TX	/	/	head	Right Cheek	0.859
2.15 ~ 2.16		GSM	1900	3	4	810	1908.8	1TX	/	/	head	Right Cheek	0.711

3.1	Call disconnection and re-establishment	Sub6 NR	7	3	4	510000	2550	DFT-OFDM QPSK	106@54	40M	head	Right Cheek	0.740
4.1	Band handover	WCDMA	4	3	4	1413	1732.6	RMC	/	/	head	Right Cheek	0.571
		LTE	4	3	4	20300	1745	QPSK	50@0	20M	head	Right Cheek	0.578
5.1	ECI change	WCDMA	4	3	4	1413	1732.6	RMC	/	/	head	Right Cheek	0.571
		WCDMA	4	3	1	1413	1732.6	RMC	/	/	Body 10mm	Top	0.693
6.1	Antenna switching	WCDMA	4	3	4	1413	1732.6	RMC	/	/	head	Right Cheek	0.571
		WCDMA	4	4	4	1513	1752.6	RMC	/	/	head	Right Cheek	0.147
7.1	SAR exposure switching	LTE	66	3	1	132322	1745	QPSK	50@0	20M	Body 10mm	Top	0.642
		Sub6 NR	38	4	1	519000	2595	DFT-OFDM QPSK	50@25	40M	Body 10mm	Bottom	0.674

6.2 Conducted Power Measurement Results for Scenario 1: Range of TA-SAR Parameters

In this scenario, two TA-SAR parameters are swept to validate Mediatek's TA-SAR algorithm. The parameter sets are summarized in Table 6-2, and the test procedure follows section 5.2.2. The measurement setup is shown in Figure 6-3. The high-level summary of the final validation results are also listed in the last column of the table, which concludes that Mediatek's TA-SAR algorithm can maintain the time-averaged SAR is always below the FCC requirement for all test case. The following section will demonstrate case-by-case to show how Mediatek's TA-SAR algorithm behaves for different parameters.

Table 6-3 TA-SAR parameters setting for scenario 1

Test case	RAT	Test band	Test seq.	ECI	Max power (dBm)	P _{sub6_limit} (dBm)	P _{LowThresh} (dBm)	P _{UE_backoff} (dBm)	P _{UE_max_cust} (dBm)	Pass /Fail SAR limit
1	WCDMA	B4	0	4	23.6	16.1	15.6	13.1	19.1	Pass

These test cases are for 3G WCDMA and are conducted under WCDMA B4 with ECI = 4. The corresponding detailed test procedure is described in 5.2.2. For the figure set of each case, the first figure demonstrates the ETU's instantaneous conducted TX power, the time-averaged conducted TX power behavior over time, and the power limit ($P_{reg_sub6_limit} = P_{sub6_limit} + \text{device uncertainty}$). The second figure illustrates the corresponding time-averaged SAR over time converted from the TX time-averaged power by using the equation listed in section 5.2.2. For all test cases, the time-averaged SAR does not exceed the FCC limit.

Case 0 in table 6-3

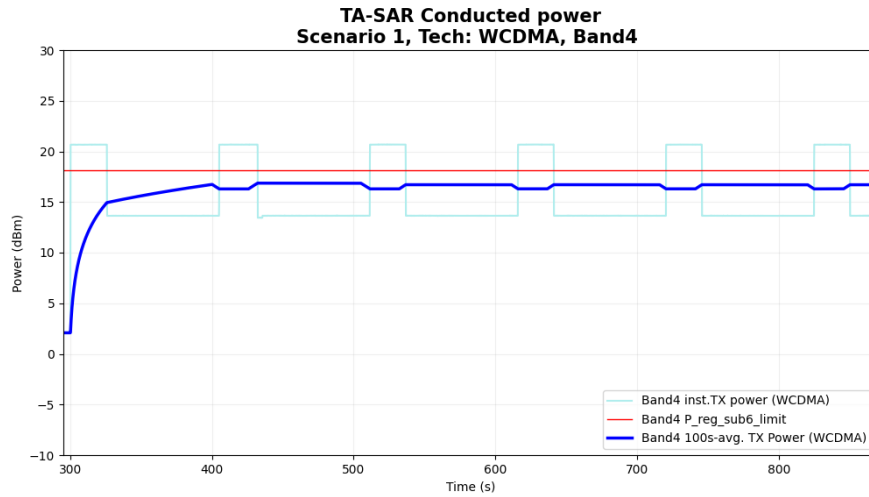

Figure 6-6 Time-averaged conducted TX power over time for case 0

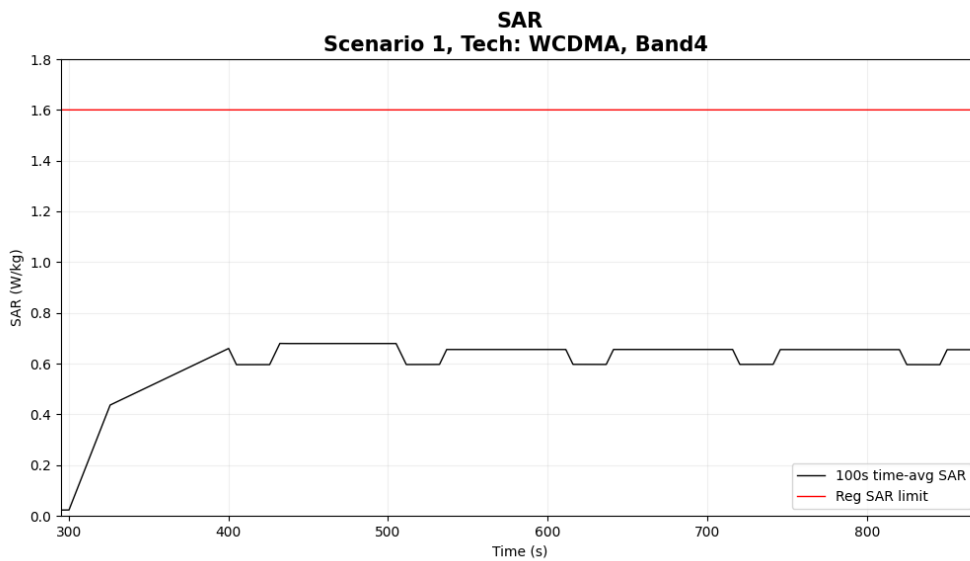

Figure 6-7 Time-averaged SAR for case 0

FCC 1gSAR limit	1.6 W/kg
Max 100s-time averaged 1gSAR	0.679 W/kg
Validation result: Pass	

6.3 Conducted Power Measurement Results for Scenario 2: Time-Varying TX Power

In this scenario, Mediatek's TA-SAR algorithm is tested under more dynamic power test sequences. The test sequence #1 is shown in section 5.1 and test sequence #2 is tabulated in Table 5-4. All of the test cases for this scenario are relegated in Table 6-2, and the test procedure follows section 5.3.2. The measurement setup is shown in Figure 6-4. The high-level summary of the final validation results are also listed in the last column of the table, which concludes that Mediatek's TA-SAR algorithm can maintain the time-averaged SAR is always below the FCC requirement for all test cases. The following sections will demonstrate case-by-case to show how Mediatek's TA-SAR algorithm behaves for each RAT.

Table 6-4 TA-SAR parameters setting for scenario 2

Test case	RAT	Test band	Test seq.	ECI	Max power (dBm)	P _{sub6_limit} (dBm)	P _{LowThresh} (dBm)	P _{UE_backoff} (dBm)	P _{UE_max_cust} (dBm)	Pass /Fail SAR limit
2.1	Sub6 NR	38	1	2	22.6	21.6	21.1	18.6	24.6	Pass
2.2	Sub6 NR	38	2	2	22.6	21.6	21.1	18.6	24.6	Pass
2.3	Sub6 NR	7	1	4	23.8	14.3	13.8	11.3	17.3	Pass
2.4	Sub6 NR	7	2	4	23.8	14.3	13.8	11.3	17.3	Pass
2.5	LTE	4	1	1	23.8	22.3	21.8	19.3	25.3	Pass
2.6	LTE	4	2	1	23.8	22.3	21.8	19.3	25.3	Pass
2.7	LTE	7	1	2	23.8	15.3	14.8	12.3	18.3	Pass
2.8	LTE	7	2	2	23.8	15.3	14.8	12.3	18.3	Pass
2.9	WCDMA	2	1	1	23.4	22.4	21.9	19.4	25.4	Pass
2.10	WCDMA	2	2	1	23.4	22.4	21.9	19.4	25.4	Pass
2.11	WCDMA	4	1	4	23.6	16.1	15.6	13.1	19.1	Pass
2.12	WCDMA	4	2	4	23.6	16.1	15.6	13.1	19.1	Pass
2.13	GSM	1900	1	2	29.3	26.3	25.8	23.3	29.3	Pass
2.14	GSM	1900	2	2	29.3	26.3	25.8	23.3	29.3	Pass
2.15	GSM	1900	1	4	29.3	25.3	24.8	22.3	28.3	Pass
2.16	GSM	1900	2	4	29.3	25.3	24.8	22.3	28.3	Pass

6.3.1 Measurement results for NR

These test cases are for sub6 NR and is conducted under NR bands n38 and n7 with $ECI=2/4$. The corresponding detailed test procedure is described in 5.3.2. For the figure set of each case, the first figure demonstrates the EUT's instantaneous conducted TX power, the time-averaged conducted TX power behavior over time, and the power limit ($P_{reg_sub_limit} = P_{sub6_limit} + \text{device uncertainty}$). The second figure illustrates the corresponding time-averaged SAR over time converted from the TX time-averaged power by using the equation listed in section 5.3.2. For all test cases, the time-averaged SAR does not exceed the FCC limit.

- Case 2.1 in table 6-4: NR n38 result for test sequence 1

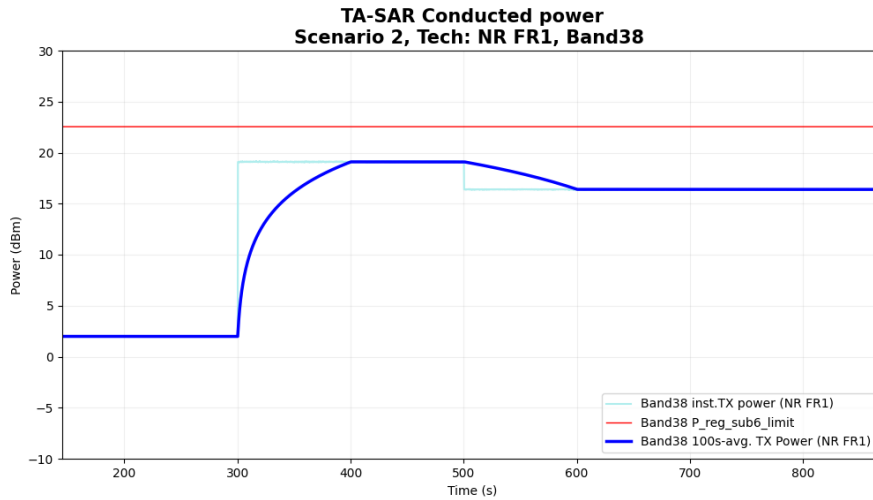

Figure 6-8 Time-averaged conducted TX power over time for case 2.1(sub6 NR n38)

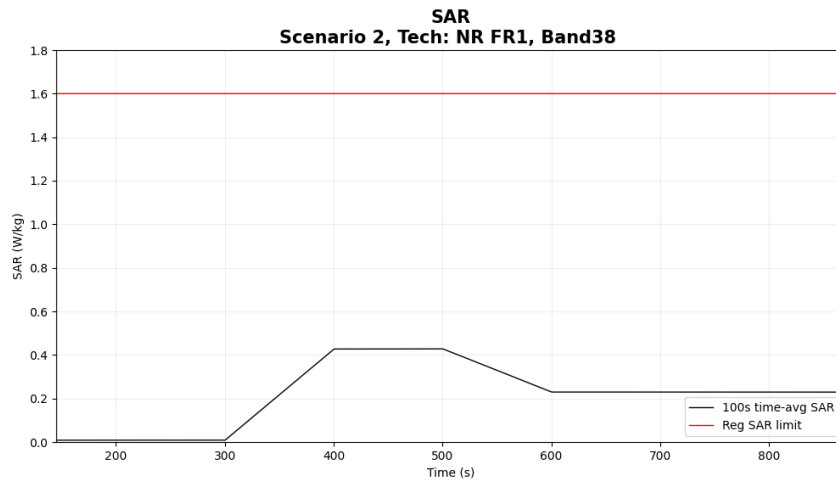

Figure 6-9 Time-averaged SAR for case 2.1(sub6 NR n38)

FCC 1gSAR limit	1.6 W/kg
Max 100s-time averaged 1gSAR	0.428 W/kg
Validation result: Pass	

- Case 2.2 in table 6-4: NR n38 result for test sequence 2

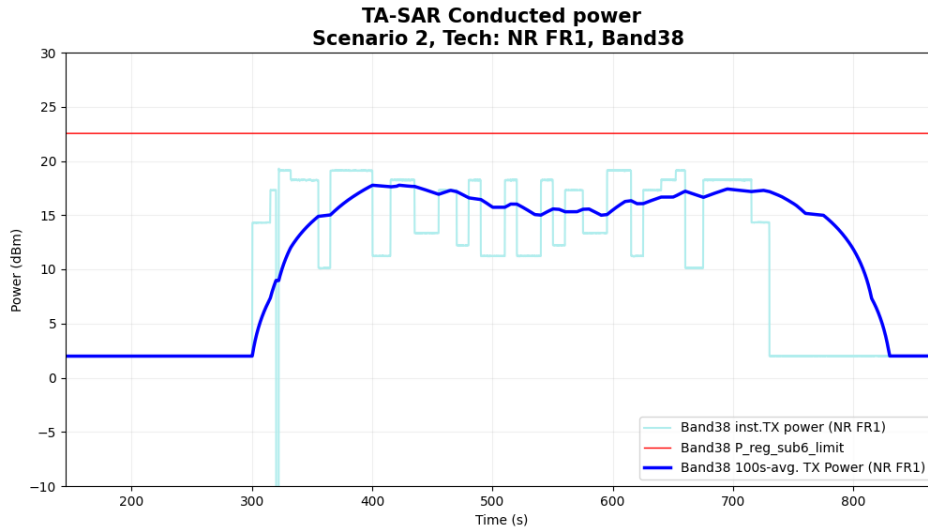

Figure 6-10 Time-averaged conducted TX power over time for case 2.2(sub6 NR n38)

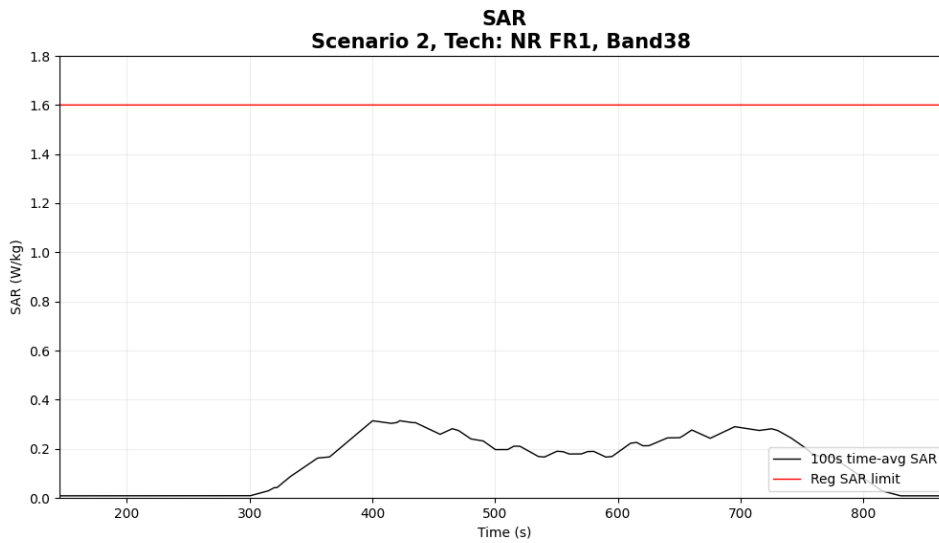

Figure 6-11 Time-averaged SAR for case 2.2(sub6 NR n38)

FCC 1gSAR limit	1.6 W/kg
Max 100s-time averaged 1gSAR	0.314 W/kg
Validation result: Pass	

- Case 2.3 in table 6-4: NR n7 result for test sequence 1

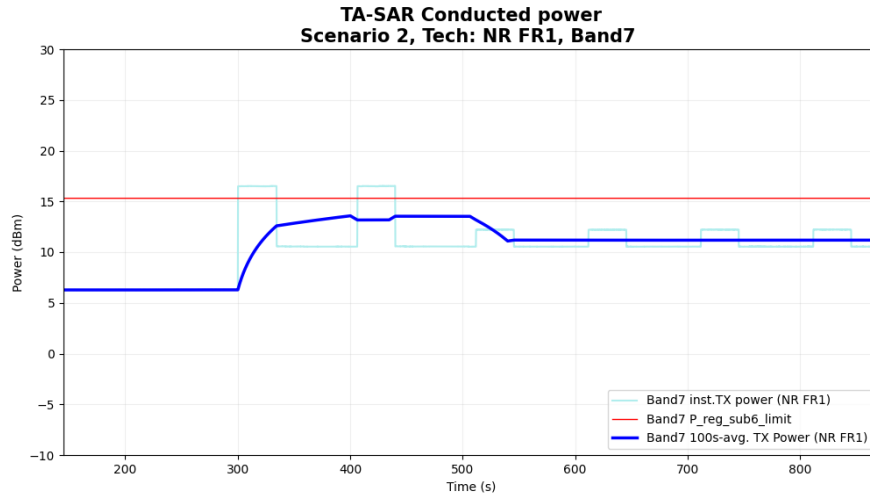

Figure 6-8 Time-averaged conducted TX power over time for case 2.3(sub6 NR n7)

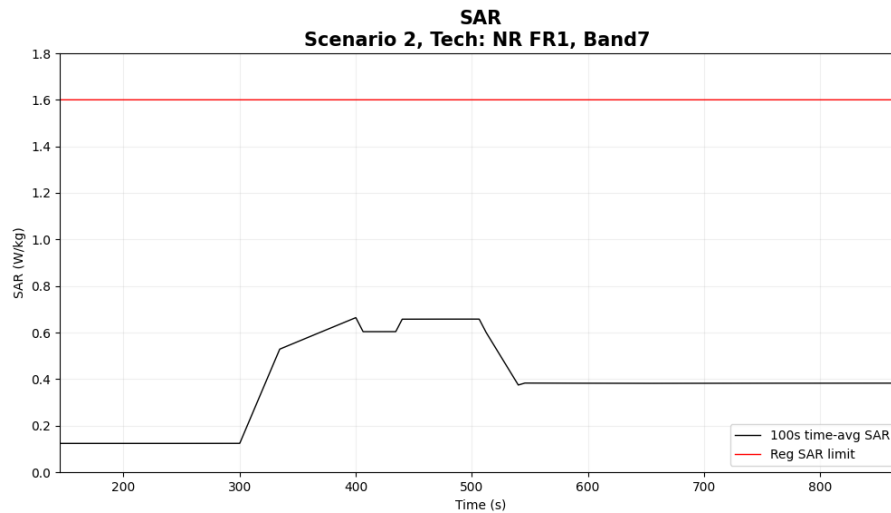

Figure 6-9 Time-averaged SAR for case 2.3(sub6 NR n7)

FCC 1gSAR limit	1.6 W/kg
Max 100s-time averaged 1gSAR	0.664 W/kg
Validation result: Pass	

- Case 2.4 in table 6-4: NR n7 result for test sequence 2

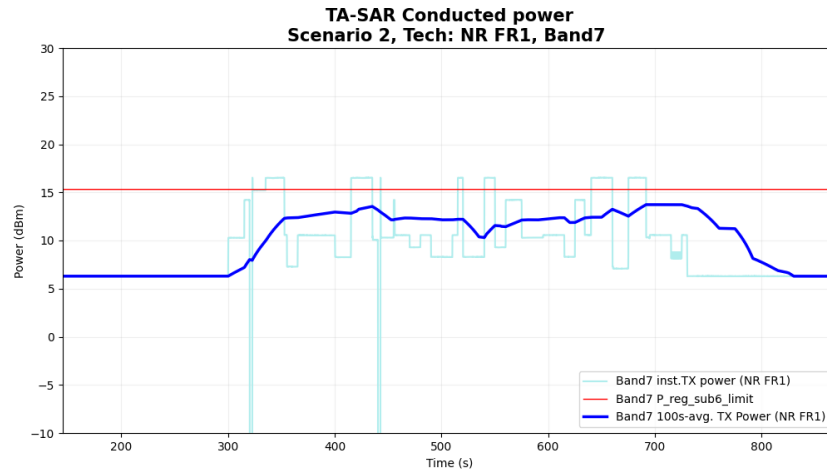

Figure 6-10 Time-averaged conducted TX power over time for case 2.4(sub6 NR n7)

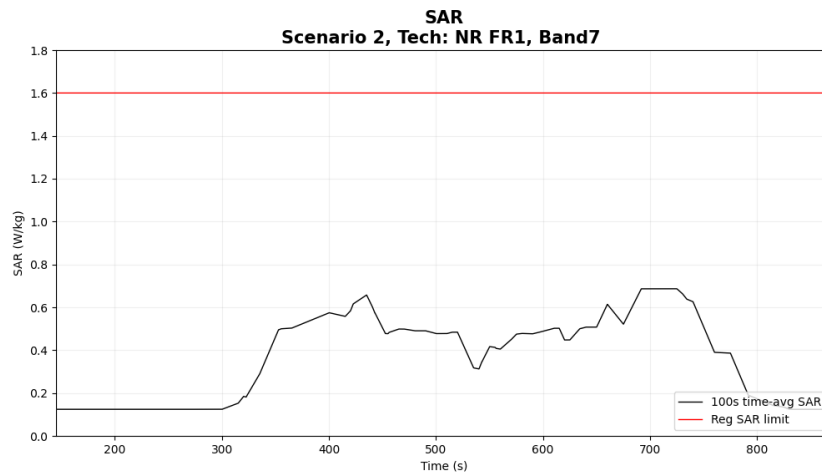

Figure 6-11 Time-averaged SAR for case 2.4(sub6 NR n7)

FCC 1gSAR limit	1.6 W/kg
Max 100s-time averaged 1gSAR	0.686 W/kg
Validation result: Pass	

6.3.1 Measurement results for LTE

These test cases are for 4G LTE and are conducted under LTE bands B4 and B7 with $ECI=1/2$. The corresponding detailed test procedure is described in 5.3.2. For the figure set of each case, the first figure demonstrates the EUT's instantaneous conducted TX power, the time-averaged conducted TX power behavior over time, and the power limit ($P_{reg_sub_limit} = P_{sub6_limit} + \text{device uncertainty}$). The second figure illustrates the corresponding time-averaged SAR over time converted from the TX time-averaged power by using the equation listed in section 5.3.2. For all test cases, the time-averaged SAR does not exceed the FCC limit.

- Case 2.5 in table 6-4: LTE B4 result for test sequence 1

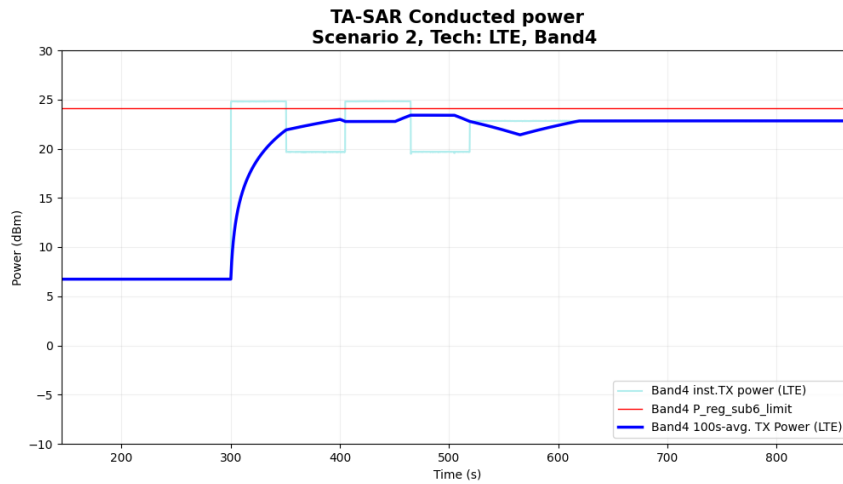

Figure 6-12 Time-averaged conducted TX power over time for case 2.5(LTE B4)

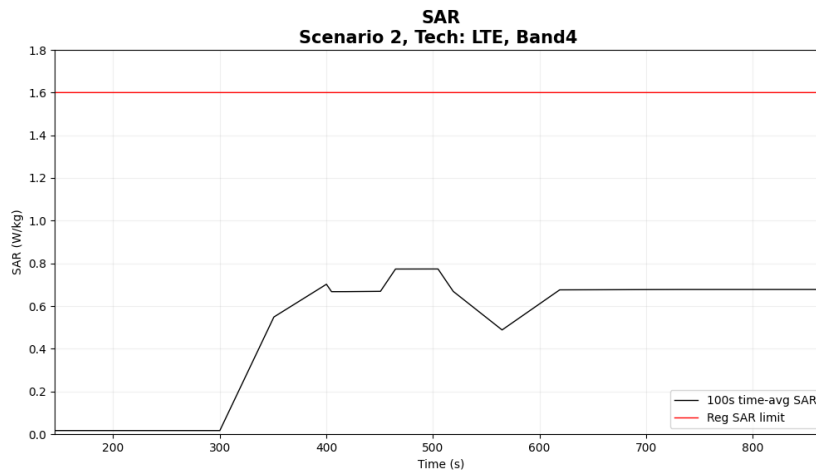

Figure 6-13 Time-averaged SAR for case 2.5(LTE B4)

FCC 1gSAR limit	1.6 W/kg
Max 100s-time averaged 1gSAR	0.774 W/kg
Validation result: Pass	

- Case 2.6 in table 6-4: LTE B4 result for test sequence 2

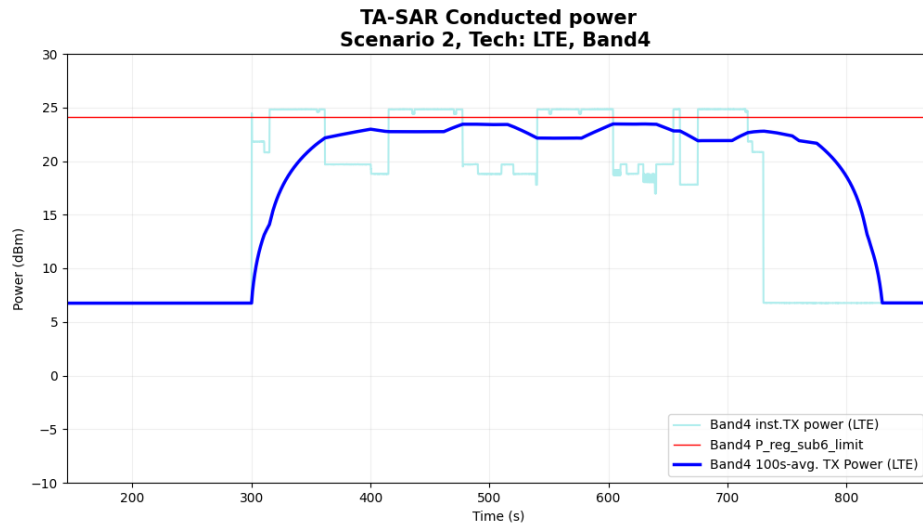

Figure 6-14 Time-averaged conducted TX power over time for case 2.6(LTE B4)

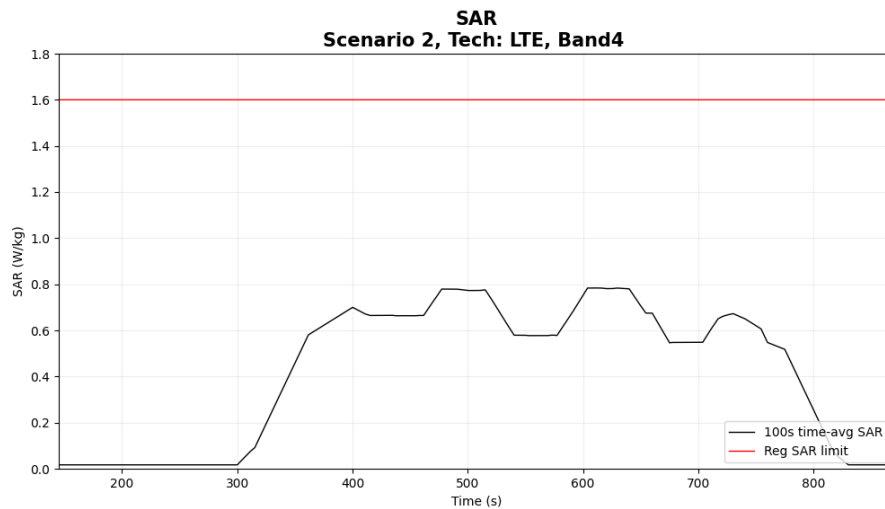

Figure 6-15 Time-averaged SAR for case 2.6(LTE B4)

FCC 1gSAR limit	1.6 W/kg
Max 100s-time averaged 1gSAR	0.784 W/kg
Validation result: Pass	

- Case 2.7 in table 6-4: LTE B7 result for test sequence 1

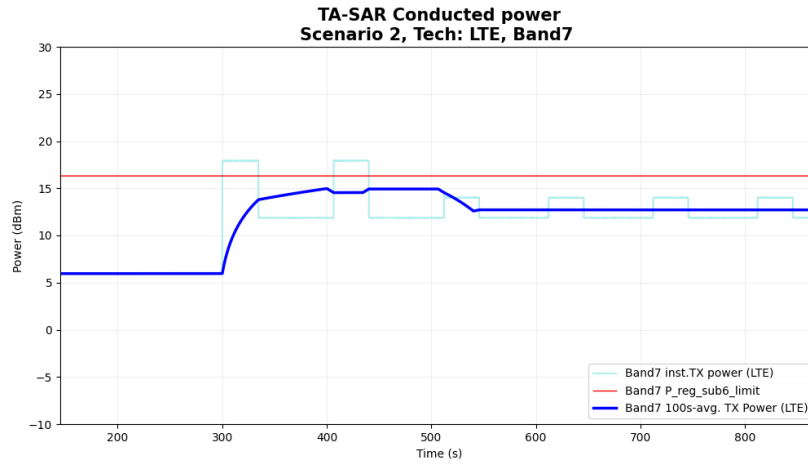

Figure 6-16 Time-averaged conducted TX power over time for case 2.7(LTE B7)

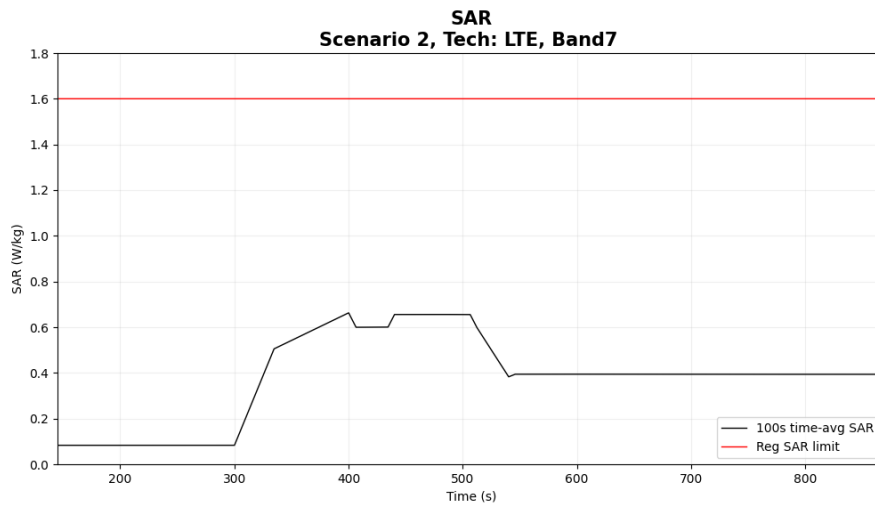

Figure 6-17 Time-averaged SAR for case 2.7(LTE B7)

FCC 1gSAR limit	1.6 W/kg
Max 100s-time averaged 1gSAR	0.633 W/kg
Validation result: Pass	

- Case 2.8 in table 6-4: LTE B7 result for test sequence 2

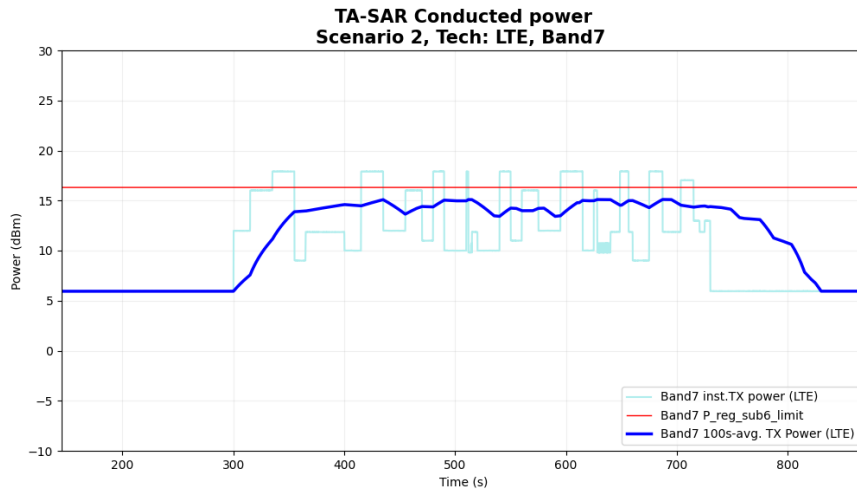

Figure 6-18 Time-averaged conducted TX power over time for case 2.8(LTE B7)

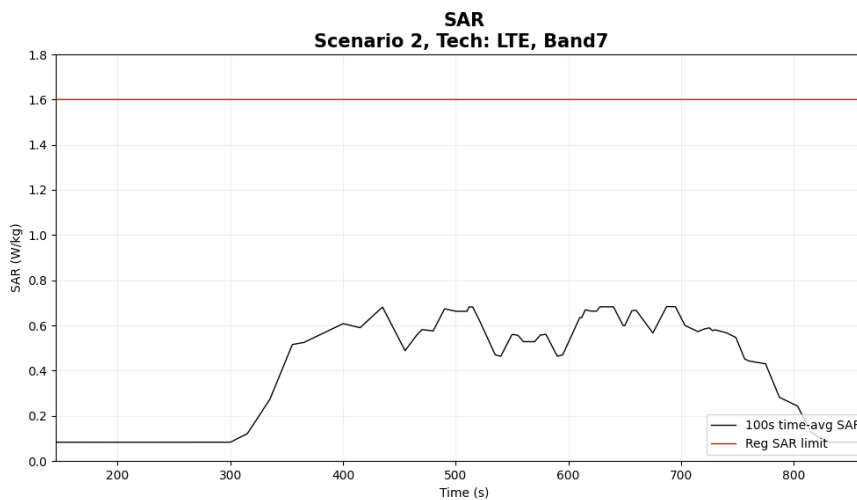

Figure 6-19 Time-averaged SAR for case 2.8(LTE B7)

FCC 1gSAR limit	1.6 W/kg
Max 100s-time averaged 1gSAR	0.684 W/kg
Validation result: Pass	

6.2.2 Measurement results for 3G WCDMA

These test cases are for 3G WCDMA and are conducted under WCDMA B2 and B4 with $ECI=1/4$. The corresponding detailed test procedure is described in 5.3.2. For the figure set of each case, the first figure demonstrates the EUT's instantaneous conducted TX power, the time-averaged conducted TX power behavior over time, and the power limit ($P_{reg_sub_limit} = P_{sub6_limit} + \text{device uncertainty}$). The second figure illustrates the corresponding time-averaged SAR over time converted from the TX time-averaged power by using the equation listed in section 5.3.2. For all test cases, the time-averaged SAR does not exceed the FCC limit.

- Case 2.9 in table 6-4: WCDMA B2 result for test sequence 1

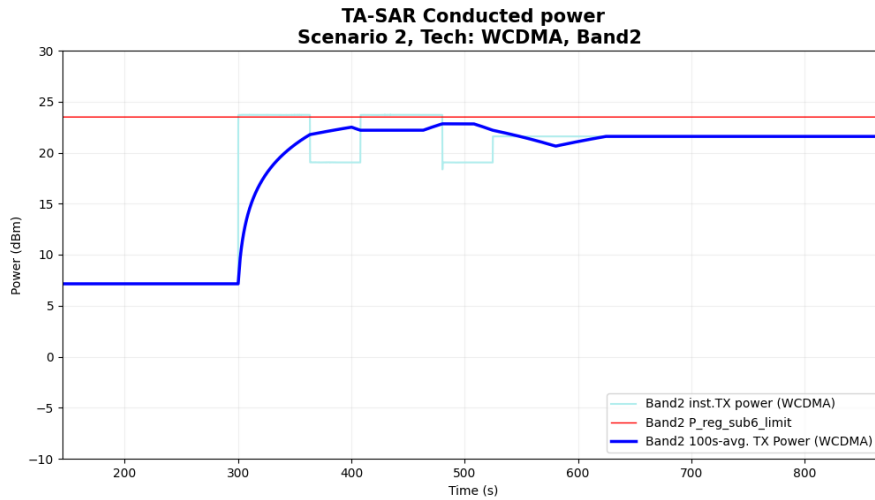

Figure 6-20 Time-averaged conducted TX power over time for case 2.9(WCDMA B2)

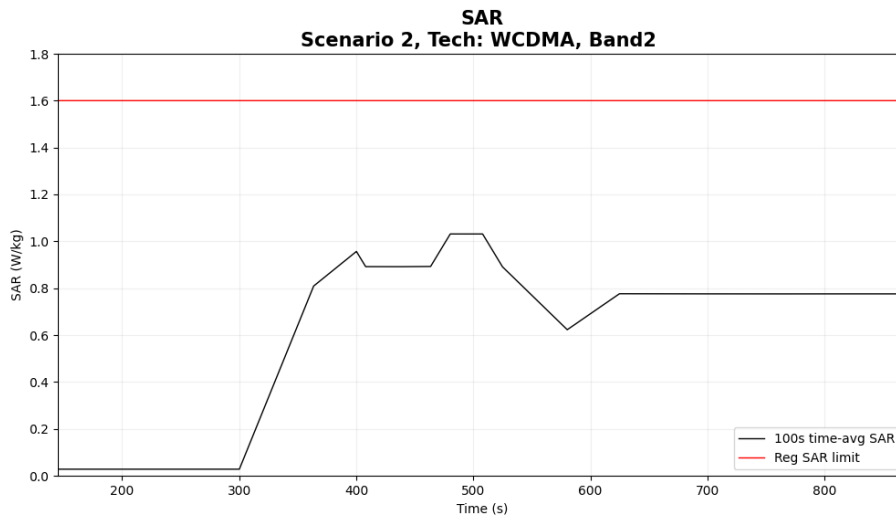

Figure 6-21 Time-averaged SAR for case 2.9(WCDMA B2)

FCC 1gSAR limit	1.6 W/kg
Max 100s-time averaged 1gSAR	1.03 W/kg
Validation result: Pass	

- Case 2.10 in table 6-4: WCDMA B2 result for test sequence 2

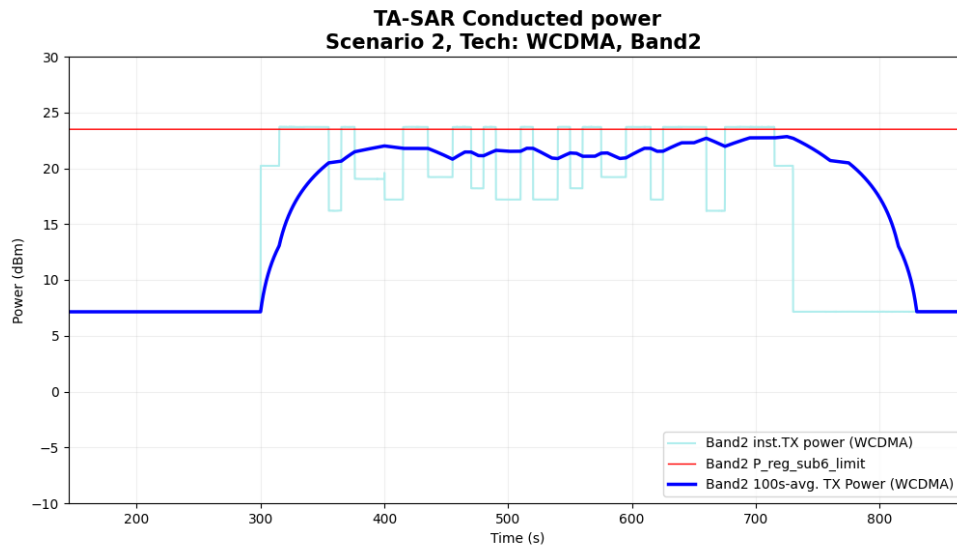

Figure 6-22 Time-averaged conducted TX power over time for case 2.10(WCDMA B2)

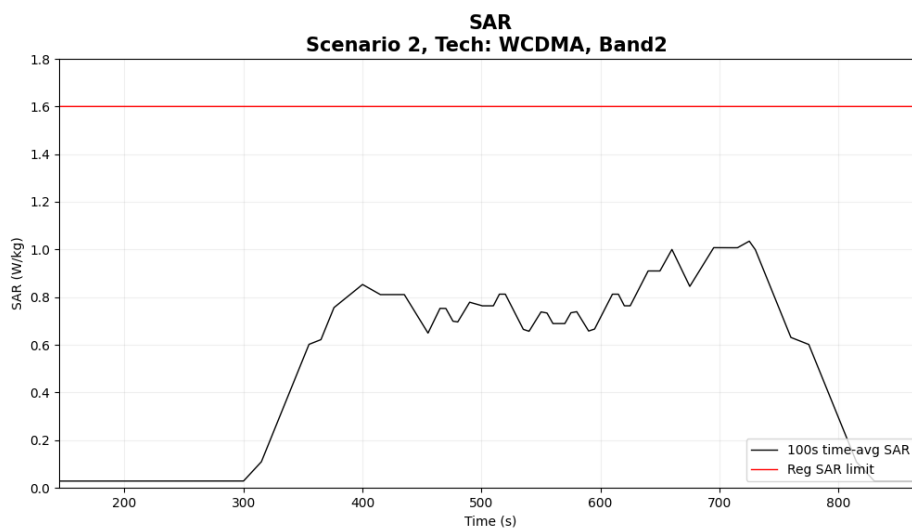

Figure 6-23 Time-averaged SAR for case 2.10(WCDMA B2)

FCC 1gSAR limit	1.6 W/kg
Max 100s-time averaged 1gSAR	1.04 W/kg
Validation result: Pass	

- Case 2.11 in table 6-4: WCDMA B4 result for test sequence 1

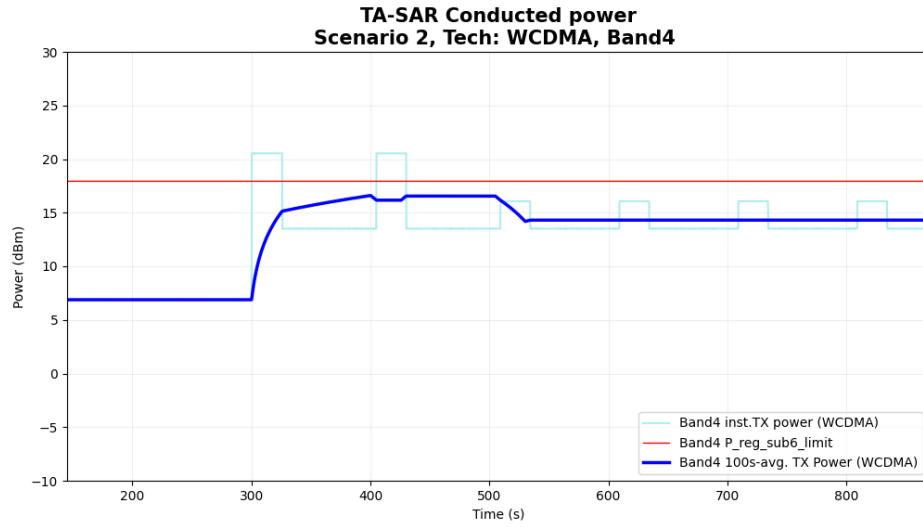

Figure 6-24 Time-averaged conducted TX power over time for case 2.11(WCDMA B4)

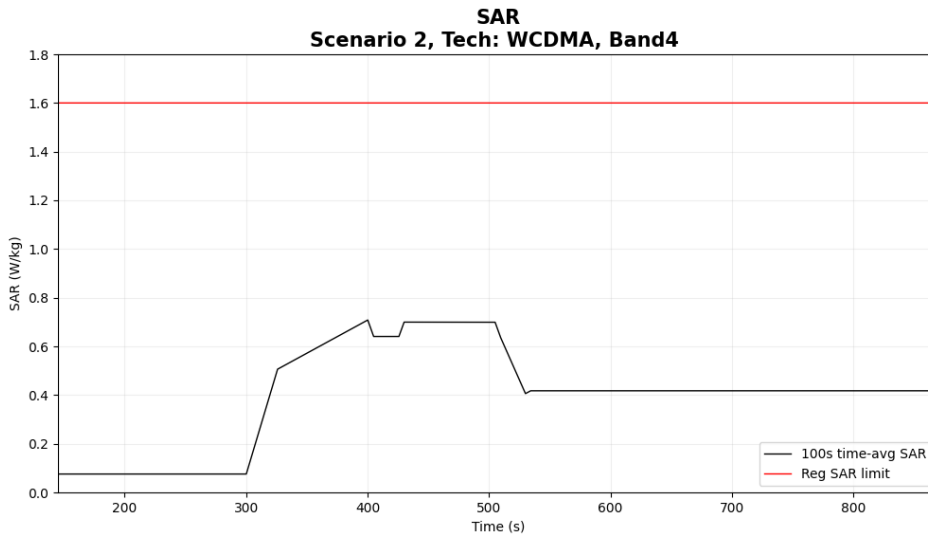

Figure 6-25 Time-averaged SAR for use 2.11(WCDMA B4)

FCC 1gSAR limit	1.6 W/kg
Max 100s-time averaged 1gSAR	0.708 W/kg
Validation result: Pass	

- Case 2.12 in table 6-4: WCDMA B4 result for test sequence 2

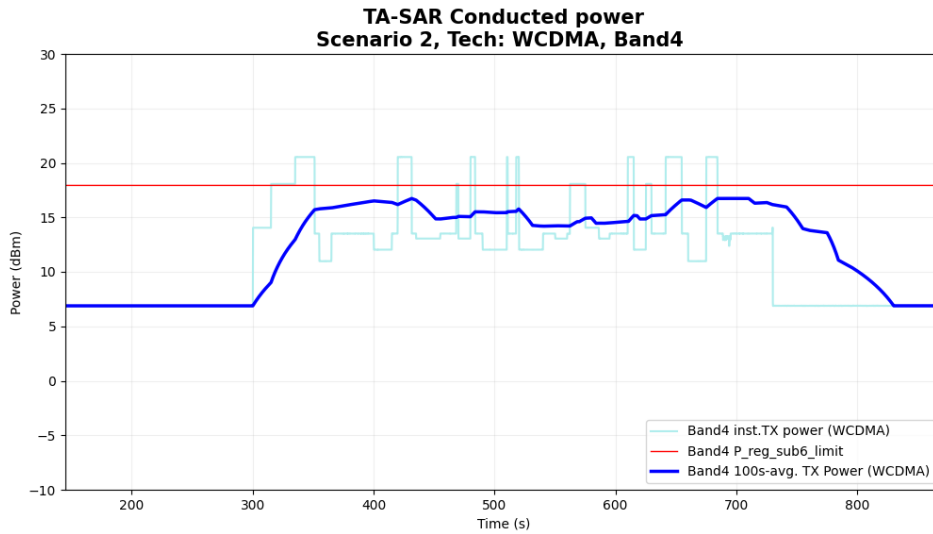

Figure 6-26 Time-averaged conducted TX power over time for case 2.12(WCDMA B4)

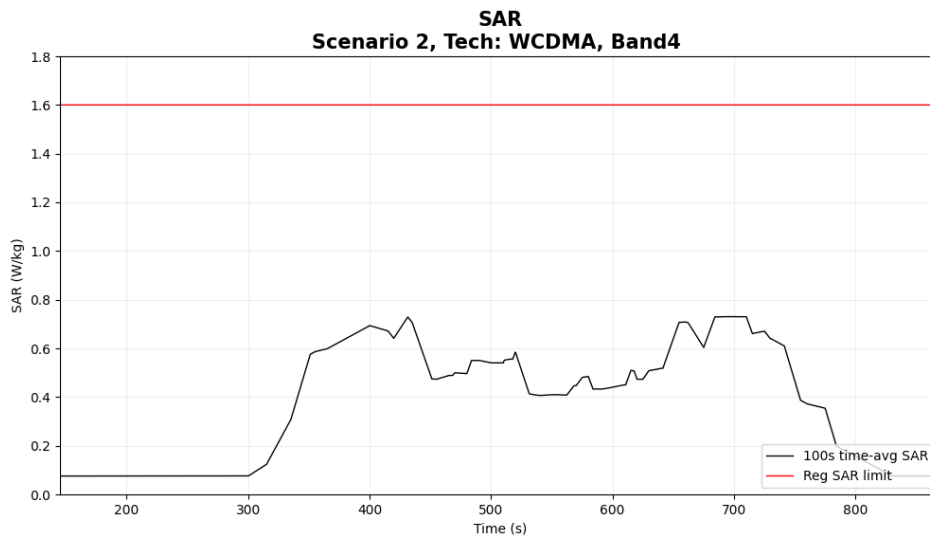

Figure 6-27 Time-averaged SAR for case case 2.12(WCDMA B4)

FCC 1gSAR limit	1.6 W/kg
Max 100s-time averaged 1gSAR	0.730 W/kg
Validation result: Pass	

6.2.2 Measurement results for 2G

These test cases are for 2G and are conducted under 2G band PCS1900 with ECI=2/4. The corresponding detailed test procedure is described in 5.3.2. For the figure set of each case, the first figure demonstrates the EUT's instantaneous conducted TX power, the time-averaged conducted TX power behavior over time, and the power limit ($P_{reg_sub_limit} = P_{sub6_limit} + \text{device uncertainty}$). The second figure illustrates the corresponding time-averaged SAR over time converted from the TX time-averaged power by using the equation listed in section 5.3.2. For all test cases, the time-averaged SAR does not exceed the FCC limit.

- Case 2.13 in table 6-4: 2G PCS 1900 result for test sequence 1

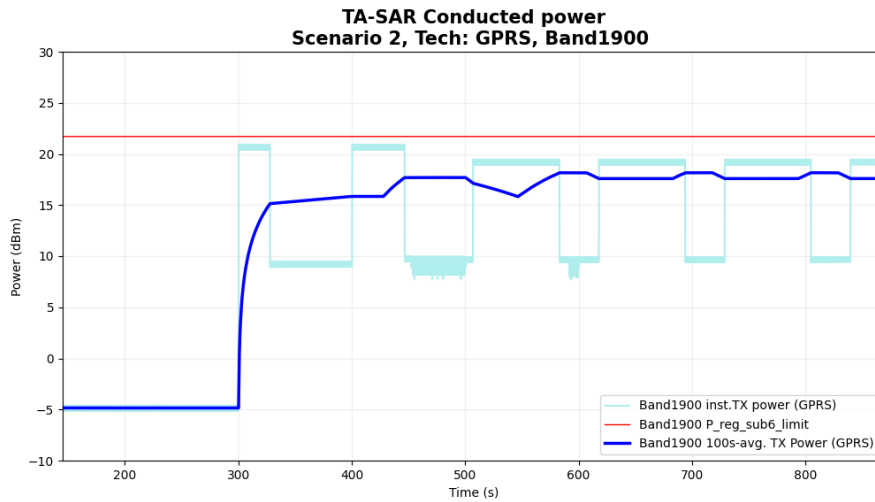

Figure 6-28 Time-averaged conducted TX power over time for case 2.13(2G PCS1900)

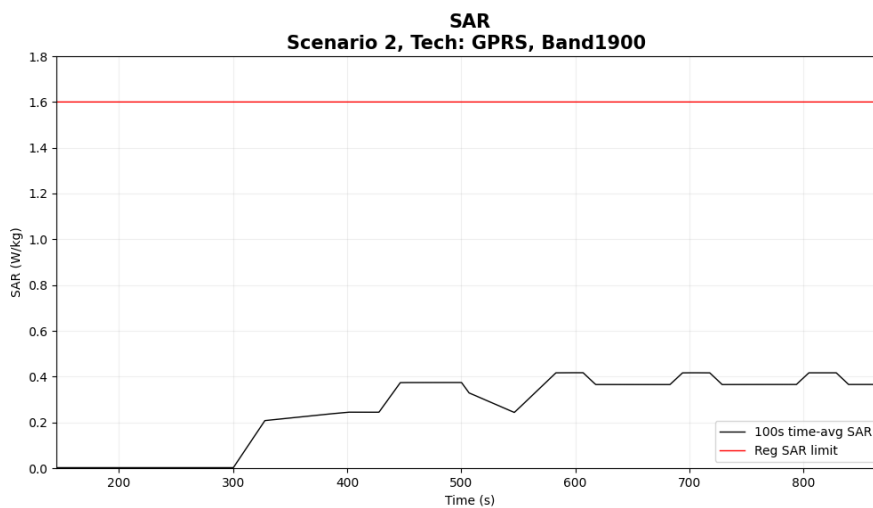

Figure 6-29 Time-averaged SAR for case 2.13(2G PCS1900)

FCC 1gSAR limit	1.6 W/kg
Max 100s-time averaged 1gSAR	0.417 W/kg
Validation result: Pass	

- Case 2.14 in table 6-4: 2G PCS 1900 result for test sequence 2

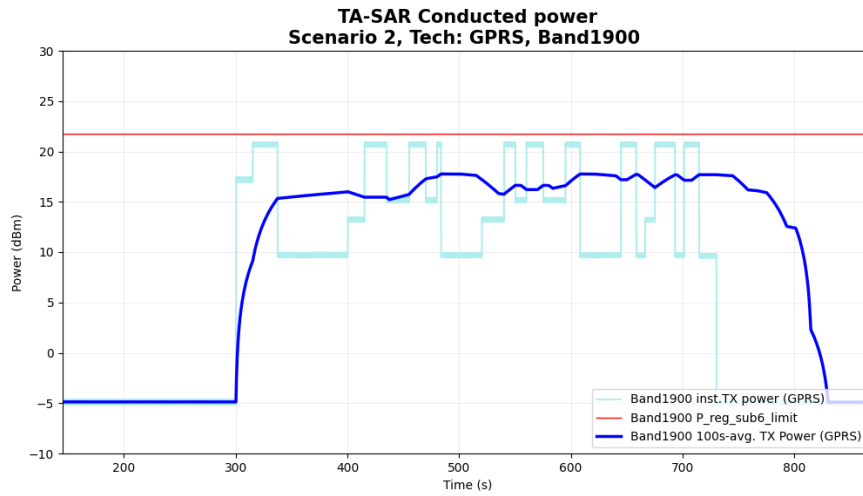

Figure 6-30 Time-averaged conducted TX power over time for case 2.14(2G PCS1900)

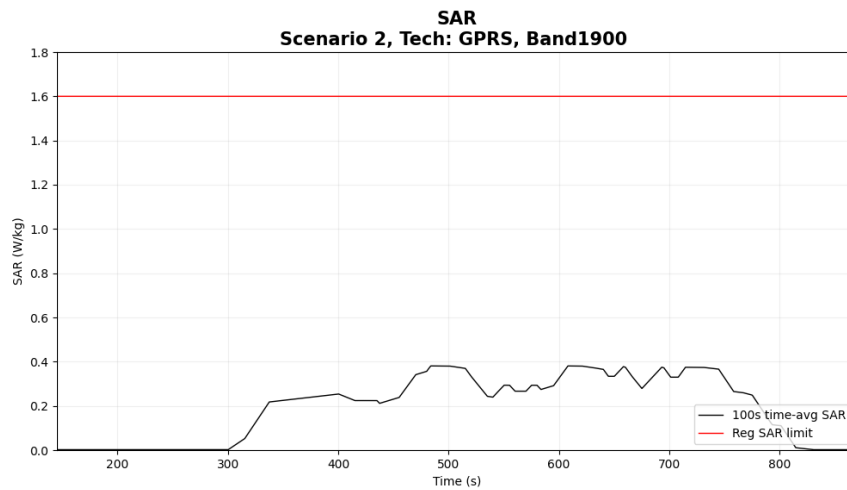

Figure 6-31 Time-averaged SAR for case 2.14(2G PCS1900)

FCC 1gSAR limit	1.6 W/kg
Max 100s-time averaged 1gSAR	0.381 W/kg
Validation result: Pass	

- Case 2.15 in table 6-4: 2G PCS 1900 result for test sequence 1

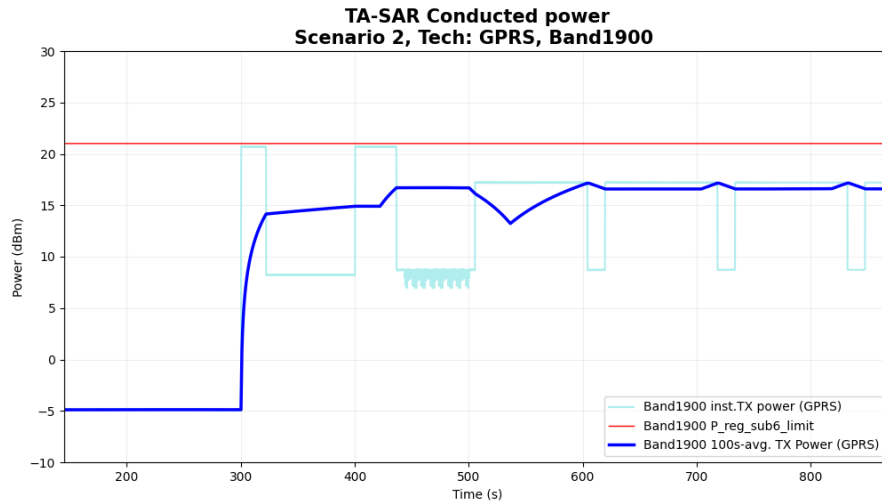

Figure 6-32 Time-averaged conducted TX power over time for case 2.15(2G PCS1900)

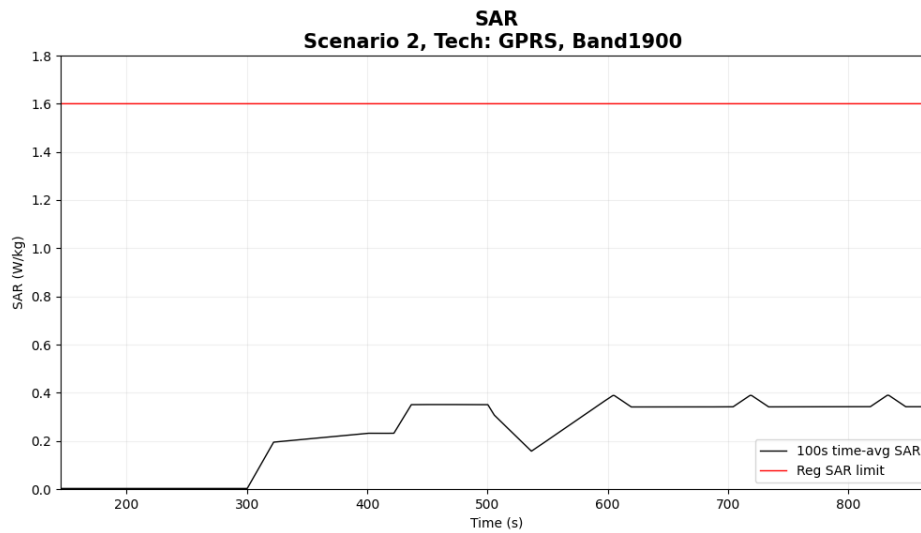

Figure 6-33 Time-averaged SAR for ase case 2.15(2G PCS1900)

FCC 1gSAR limit	1.6 W/kg
Max 100s-time averaged 1gSAR	0.389 W/kg
Validation result: Pass	

- Case 2.16 in table 6-4: 2G PCS 1900 result for test sequence 2

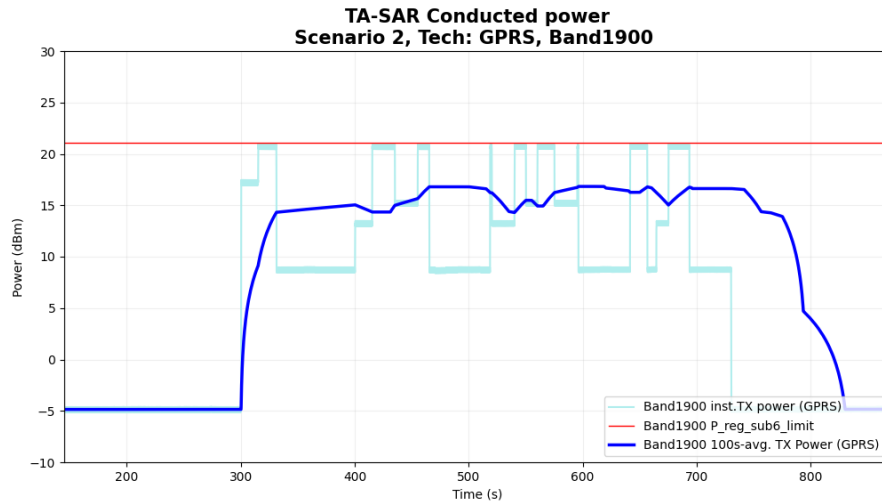

Figure 6-34 Time-averaged conducted TX power over time for case 2.16(2G PCS1900)

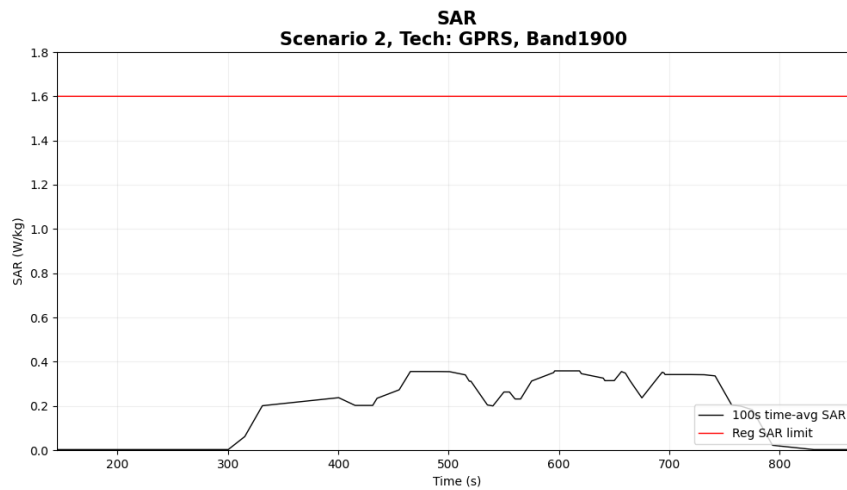

Figure 6-35 Time-averaged SAR for case 2.16(2G PCS1900)

FCC 1gSAR limit	1.6 W/kg
Max 100s-time averaged 1gSAR	0.358 W/kg
Validation result: Pass	

6.4 Conducted Power Measurement Results for Scenario 3: Call Disconnection and Re-establishment

In this scenario, the test power sequence #0 (i.e., maximum TX power is requested by a call box for each RAT) is used, and the call drop is manually configured for a pre-defined period and then the call is re-established to continue data transmission. The test case for this scenario is relegated in Table 6-5, and the test procedure follows section 5.4.2. The measurement setup is Figure 6-2. The high-level summary of the final validation results is also listed in the last column of the table, which concludes that Mediatek's TA-SAR algorithm can maintain the time-averaged SAR is always below the FCC requirement. The following section will demonstrate how Mediatek's TA-SAR algorithm behaves.

Table 6-5 TA-SAR parameters setting for scenario 3

Test case	RAT	Test band	Test seq.	ECI	Max power (dBm)	P _{sub6_limit} (dBm)	P _{LowThresh} (dBm)	P _{UE_backoff} (dBm)	P _{UE_max_cust} (dBm)	Pass /Fail SAR limit
3.1	Sub6 NR	7	0	4	23.8	14.3	13.8	11.3	17.3	Pass

This test is for sub6 NR and is conducted under NR band n7 with ECI = 4. The corresponding detailed test procedure is described in 5.4.2. Figure 6-36 demonstrates the EUT's instantaneous conducted TX power, the time-averaged conducted TX power behavior over time, and the power limit ($P_{reg_sub6_limit} = P_{sub6_limit} + \text{device uncertainty}$). Figure 6-37 illustrates the corresponding time-averaged SAR over time converted from the TX time-averaged power by using the equation listed in section 5.4.2. As seen in this figure, the time-averaged SAR does not exceed the FCC limit.

- Case 3.1 in table 6-5: call drop happens at the time instance of 500 seconds

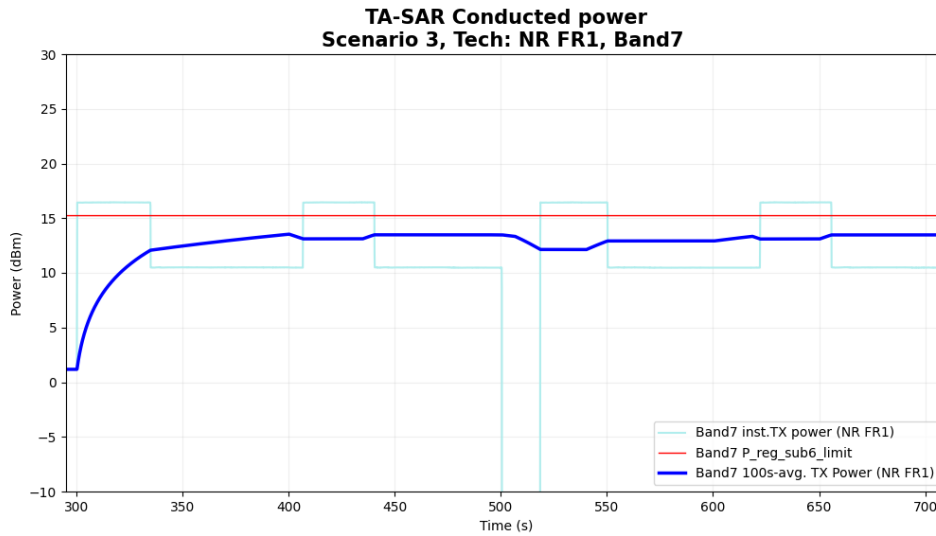

Figure 6-36 Time-averaged conducted TX power over time for case 3.1(sub6 NR n7)

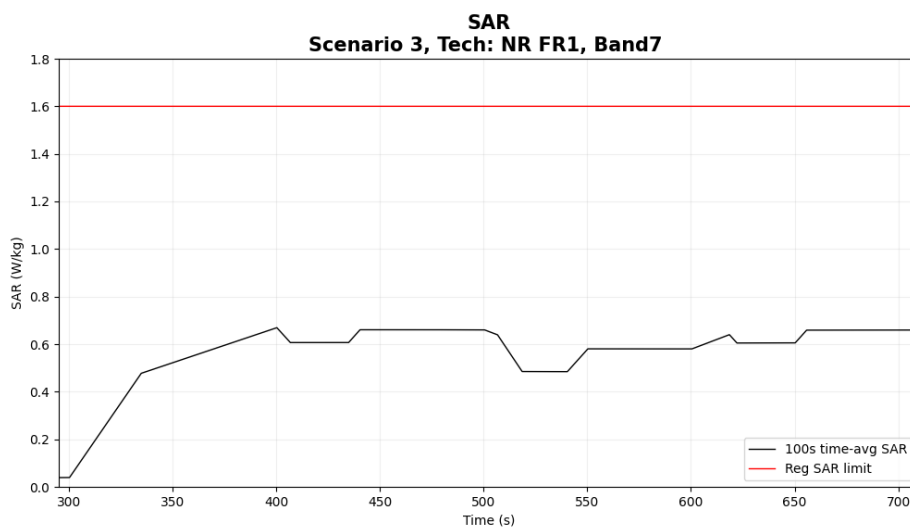

Figure 6-37 Time-averaged SAR for case 3.1(sub6 NR n7)

FCC 1gSAR limit	1.6 W/kg
Max 100s-time averaged 1gSAR	0.669 W/kg
Validation result: Pass	

6.5 Conducted Power Measurement Results for Scenario 4: Band Handover

In this scenario, the test power sequence #0 (i.e., maximum TX power is requested by a call box for each RAT) is used, and band (and RAT) handover is manually configured at a specific time instance. The test case widely cover handover scenarios between two RATs. The test case for this scenario is relegated in Table 6-6, and the test procedure follows section 5.5.2. The measurement setup is shown in Figure 6-3 (band handover) and Figure 6-5 (RAT handover). The high-level summary of the final validation results are also listed in the last column of the table, which concludes that Mediatek's TA-SAR algorithm can maintain the time-averaged SAR is always below the FCC requirement. The following sections will demonstrate how Mediatek's TA-SAR algorithm behaves.

Table 6-6 TA-SAR parameters setting for scenario 4

Test case	RAT	Test band	Test seq.	ECI	Max power (dBm)	P _{sub6_limit} (dBm)	P _{LowThresh} (dBm)	P _{UE_backoff} (dBm)	P _{UE_max_cust} (dBm)	Pass /Fail SAR limit
4.1	WCDMA	4	0	4	23.6	16.1	15.6	13.1	19.1	Pass
	LTE	4	0	1	23.8	16.3	15.8	13.3	19.3	Pass

This test aims to validate the TA-SAR algorithm with a handover from WCDMA band B4 to LTE band B4 and ECI = 4. The corresponding detailed test procedure is described in 5.5.2. The first figure demonstrates the EUT's instantaneous conducted TX power and the time-averaged conducted TX power behavior over time, and the power Limit ($P_{reg_sub6_limit} = P_{sub6_limit} + \text{device uncertainty}$). The handover is configured at the time instance of 500 seconds. It is observed in the figure that the time-averaged TX power of the individual RAT is below its own P_{sub6_limit} . The second figure illustrates the corresponding time-averaged normalized SAR over time converted from the TX time-averaged power by using the equation listed in section 5.5.2. The figure shows that the time-averaged normalized SAR does not exceed the normalized FCC limit of 1.

- Case 4.1 in table 6-6: band handover happens at the time instance of 500 seconds

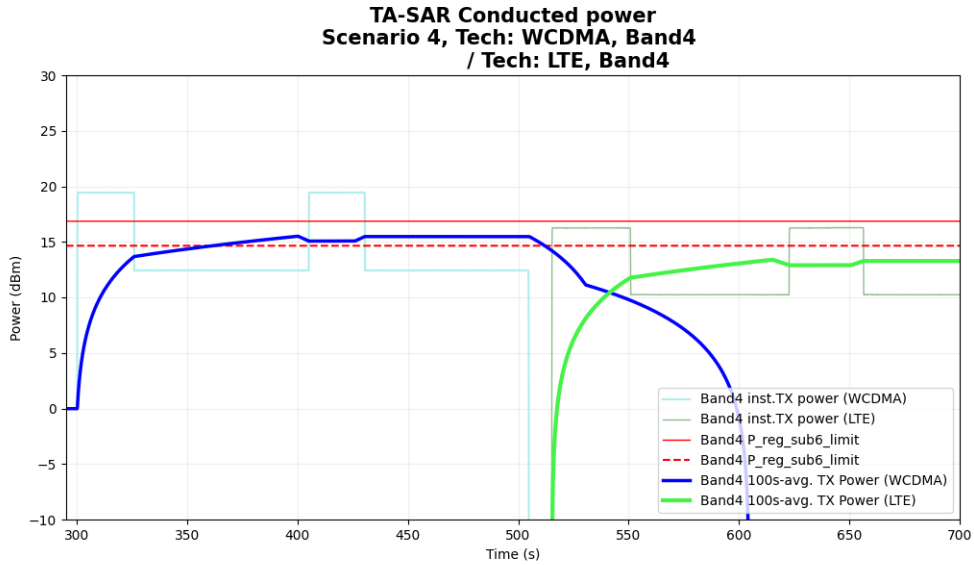

Figure 6-38 Time-averaged conducted TX power over time for case 4.1(WCDMA B4, LTE B4)

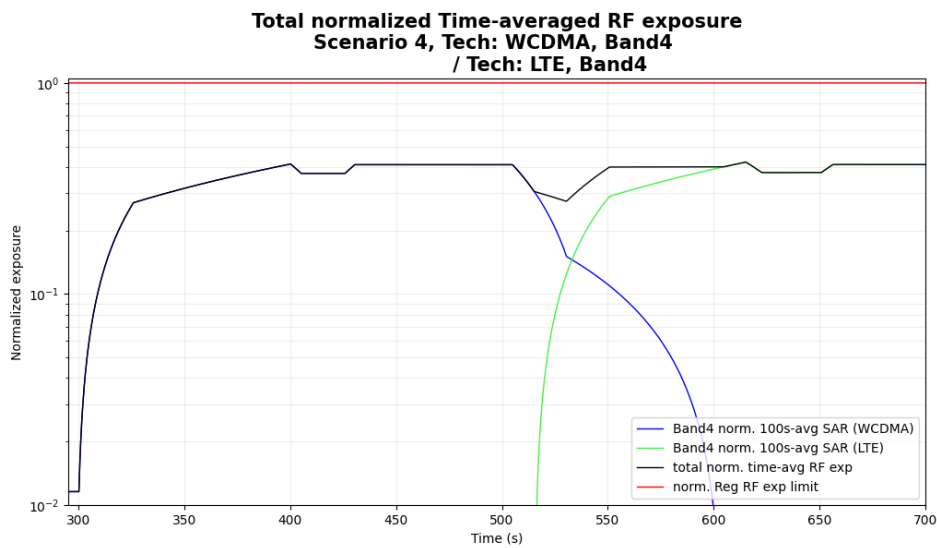

Figure 6-39 Time-averaged SAR for case 4.1(WCDMA B4, LTE B4)

FCC limit of total RF exposure (normalized)	1.0
Max total normalized time-averaged RF exposure	0.422
Validation result: Pass	

6.6 Conducted Power Measurement Results for Scenario 5: ECI Change

In this scenario, the test power sequence #0 (i.e., maximum TX power is requested by a call box for each RAT) is used, and ECI change at the EUT side is manually configured at a specific time instance. The test case cover ECI switching scenarios between two ECIs. The test case for this scenario is relegated in Table 6-7, and the test procedure follows section 5.6.2. The measurement setup is shown in Figure 6-2. The high-level summary of the final validation results are also listed in the last column of the table, which concludes that Mediatek's TA-SAR algorithm can maintain the time-averaged SAR is always below the FCC requirement. The following sections will demonstrate how Mediatek's TA-SAR algorithm behaves.

Table 6-7 TA-SAR parameters setting for scenario 5

Test case	RAT	Test band	Test seq.	ECI	Max power (dBm)	P _{sub6_limit} (dBm)	P _{LowThresh} (dBm)	P _{UE_backoff} (dBm)	P _{UE_max_cust} (dBm)	Pass /Fail SAR limit
5.1	WCDMA	4	0	4	23.6	16.1	15.6	13.1	19.1	Pass
	WCDMA	4	0	1	23.6	22.1	21.6	19.1	25.1	Pass

This test aims to validate the TA-SAR algorithm with ECI change from 3G WCDMA B4 with ECI = 4 to ECI = 1. The corresponding detailed test procedure is described in 5.6.2. The first figure demonstrates the EUT's instantaneous conducted TX power and the time-averaged conducted TX power behavior over time, and the power Limit ($P_{reg_sub6_limit} = P_{sub6_limit} + \text{device uncertainty}$). During the test period, there are two ECI change events configured individually at the time instance of 500 seconds and 700 seconds. The 1st change is from ECI = 4 to ECI = 1 and 2nd change is from ECI= 1 back to ECI = 4. It is observed in the figure that the time-averaged TX power of the individual RAT is below its own P_{sub6_limit}. The second figure illustrates the corresponding time-averaged normalized SAR over time converted from the TX time-averaged power by using the equation listed in section 5.6.2. The figure shows that the time-averaged normalized SAR does not exceed the normalized FCC limit of 1.

- Case 5.1 in table 6-7: two ECI changes happens at the time instance of 500 seconds and 700 seconds, respectively

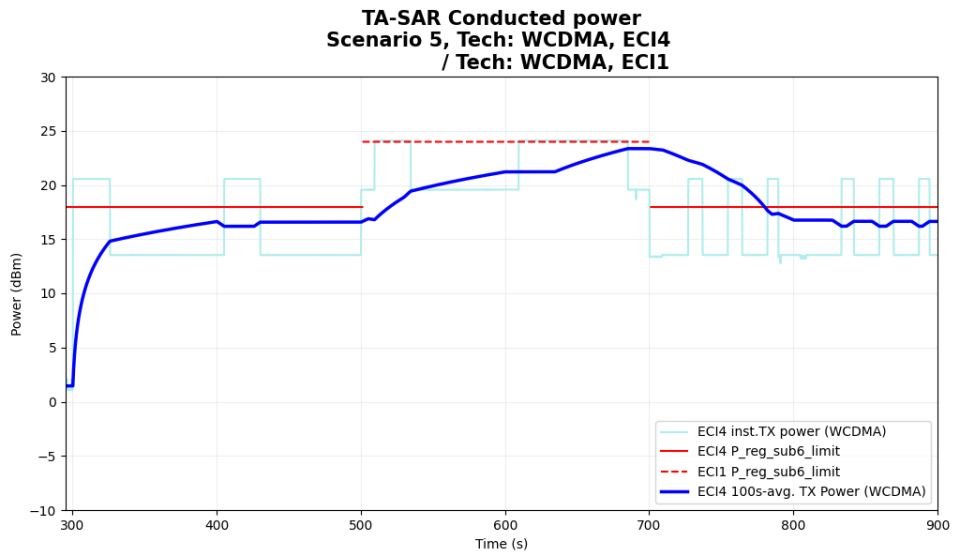

Figure 6-40 Time-averaged conducted TX power over time for case 5.1(WCDMA B4)

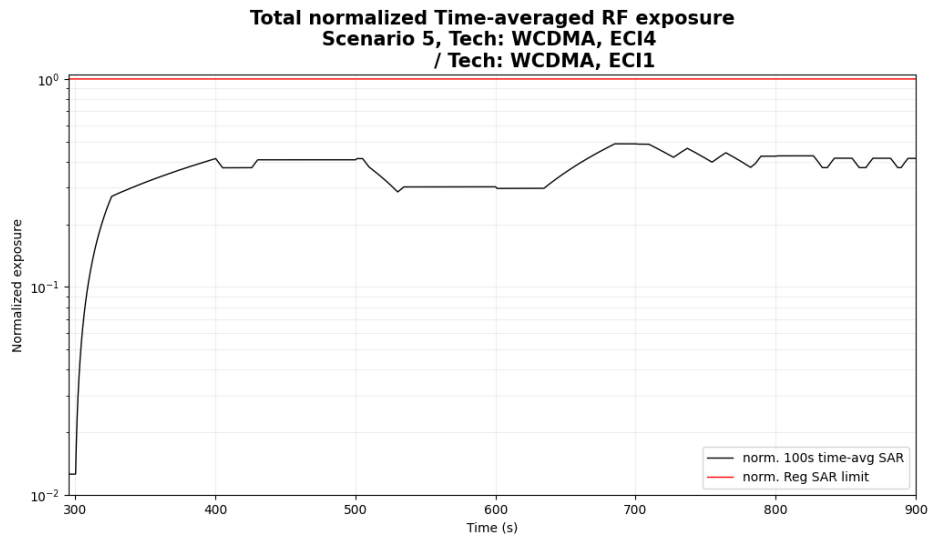

Figure 6-41 Time-averaged SAR for case 5.1(WCDMA B4)

FCC limit of total RF exposure (normalized)	1.0
Max total normalized time-averaged RF exposure	0.488
Validation result: Pass	

6.7 Conducted Power Measurement Results for Scenario 6: Antenna Handover

In this scenario, the test power sequence #0 (i.e., maximum TX power is requested by a call box for each RAT) is used, and antenna change at the EUT side is manually configured at a specific time instance. The test case for this scenario is relegated in Table 6-8, and the test procedure follows section 5.7.2. The measurement setup is shown in Figure 6-4. The high-level summary of the final validation results are also listed in the last column of the table, which concludes that Mediatek's TA-SAR algorithm can maintain the time-averaged SAR is always below the FCC requirement. The following sections will demonstrate how Mediatek's TA-SAR algorithm behaves.

Table 6-8 TA-SAR parameters setting for scenario 6

Test case	RAT	Test band	Test seq.	ANT	ECI	Max power (dBm)	P _{sub6_limit} (dBm)	P _{LowThresh} (dBm)	PUE _{backoff} (dBm)	PUE _{max_cust} (dBm)	Pass /Fail SAR limit
6.1	WCDMA	4	0	3	4	23.6	16.1	15.6	13.1	19.1	Pass
	WCDMA	4	0	4	4	24	20	19.5	17	23	Pass

This test aims to validate the TA-SAR algorithm with antenna change during the test period for WCDMA B4 with ECI = 4. The corresponding detailed test procedure is described in 5.7.2. The first figure demonstrates the EUT's instantaneous conducted TX power and the time-averaged conducted TX power behavior over time, and the power Limit ($P_{reg_sub6_limit} = P_{sub6_limit} + \text{device uncertainty}$). During the test period, there are two antenna change events configured individually at the time instances 500 seconds and 700 seconds. The 1st change is from ANT3 to ANT4 and 2nd change is ANT4 back to ANT3. It is observed in the figure that the time-averaged TX power during the transition of the change is maintained below the power limitation. The second figure illustrates the corresponding time-averaged normalized SAR over time converted from the TX time-averaged power by using the equation listed in section 5.7.2. The figure shows that the time-averaged normalized SAR does not exceed the normalized FCC limit of 1.

- Case 6.1 in table 6-6: band handover happens at the time instance of 500 seconds

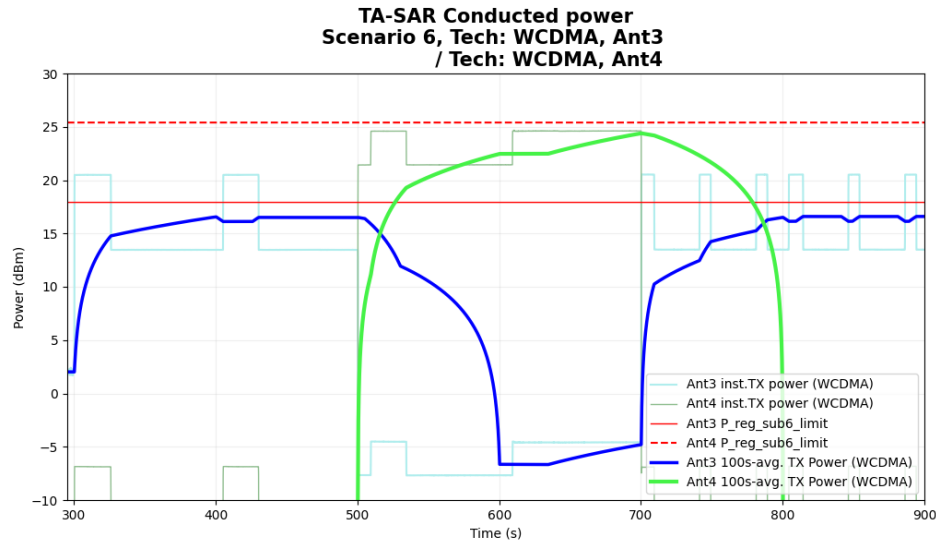

Figure 6-38 Time-averaged conducted TX power over time for case 4.1(WCDMA B4, LTE B4)

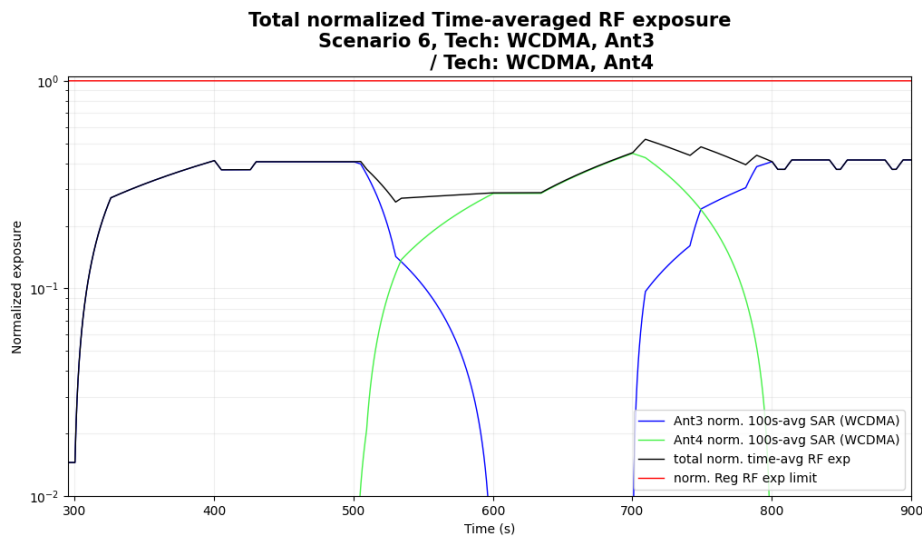

Figure 6-39 Time-averaged SAR for case 4.1(WCDMA B4, LTE B4)

FCC limit of total RF exposure (normalized)	1.0
Max total normalized time-averaged RF exposure	0.523
Validation result: Pass	

6.8 Conducted Power Measurement Results for Scenario 7: SAR Exposure Switching

In this scenario, the test power sequence #0 (i.e., maximum TX power is requested by a call box for each RAT) is used, and LTE and NR FR1 are turned on at the same time for a pre-defined period during the test. This scenario aims to validate whether the TA-SAR algorithm is able to maintain TER below the FCC limit when the two radios change TX power dynamically. The experiment parameters are summarized in Table 6-9, and the test procedure follows section 5.9.2. The measurement setup is shown in Figure 6-5.

Table 6-9 TA-SAR parameters setting for scenario 7

Test case	RAT	Test band	Test seq.	ANT	ECI	Max power (dBm)	P_{sub6_limit} (dBm)	$P_{LowThresh}$ (dBm)	$P_{UE_backoff}$ (dBm)	$P_{UE_max_cust}$ (dBm)	Pass /Fail SAR limit
7.1	LTE	66	0	3	1	23.8	21.8	21.3	18.8	24.8	Pass
	Sub6 NR	38	0	4	1	24	18.5	18	15.5	21.5	Pass

During the test period,

- Time = 300s~500s: NR FR1-dominant scenario.
- Time = 500s~7000s: LTE + NR FR1 scenario.
- Time = 700s~900s: LTE-dominant scenario.

The first figure demonstrates the EUT's instantaneous conducted TX power and the time-averaged conducted TX power behavior over time, and the power limit ($P_{reg_sub6_limit} = P_{sub6_limit} + \text{device uncertainty}$). It is observed in the figure that the time-averaged TX power in all time periods is maintained below the power limitation. The second figure illustrates the corresponding time-averaged normalized SAR over time converted from the TX time-averaged power by using the equation listed in section 5.9.2. The figure shows that the time-averaged normalized SAR does not exceed the normalized FCC limit of 1.

- Case 7.1 in table 6-9

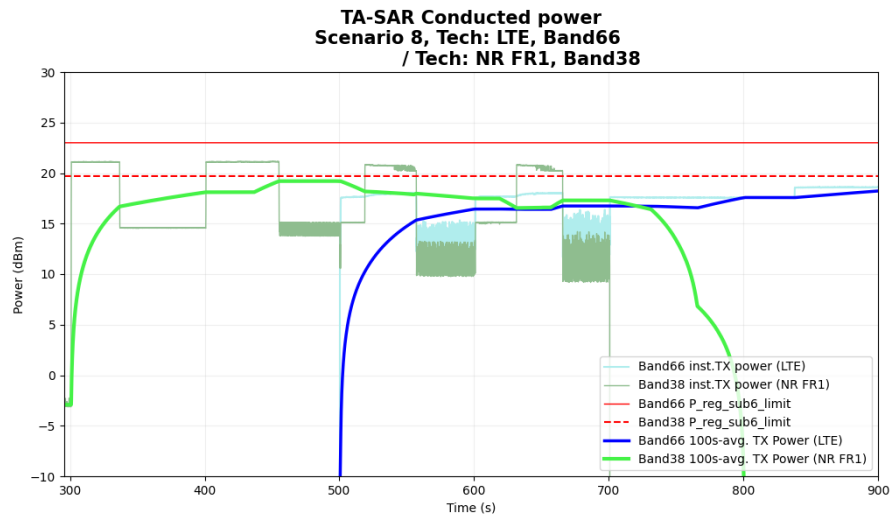

Figure 6-40 Time-averaged conducted TX power over time

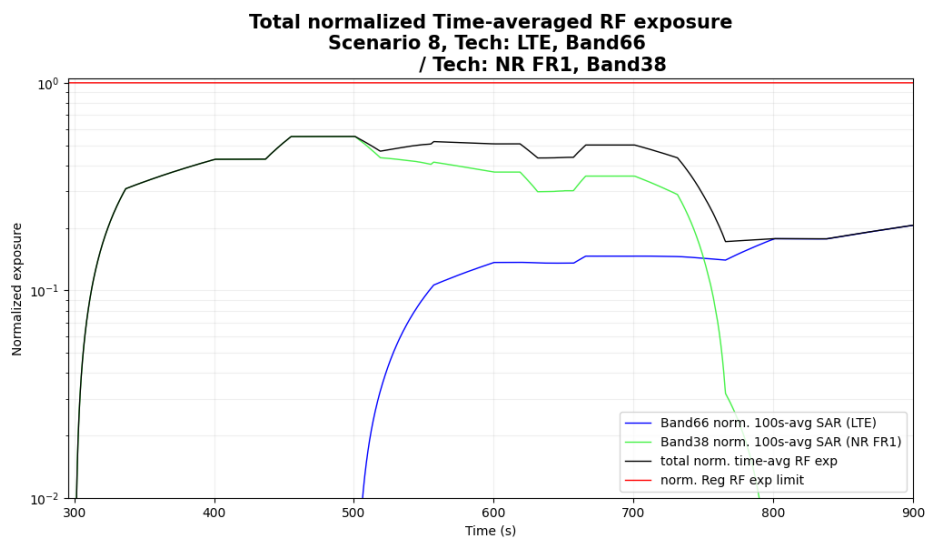

Figure 6-41 Normalized Time-averaged SAR

FCC limit of total RF exposure (normalized)	1.0
Max total normalized time-averaged RF exposure	0.552
Validation result: Pass	

7 TA-SAR Validation via SAR Measurements

7.1 Measurement Setup

The measurement setup is similar to normal fixed power SAR measurement. The difference in SAR measurement setup for time averaging feature validation is that the call box operates under the close loop power control mode and is connected to the PC, so that the PC can control the call box based on the test sequence to configure EUT's TX target power. The same test procedure used in conducted power setup for time-varying TX power measurement is also used in this section for time-averaging SAR measurements. Since the SAR chamber is an uncontrolled environment, the path loss between call box antenna and the EUT are well calibrated. The test setup is illustrated in Figure 7-1, and its photos are shown in Figure 7-2.

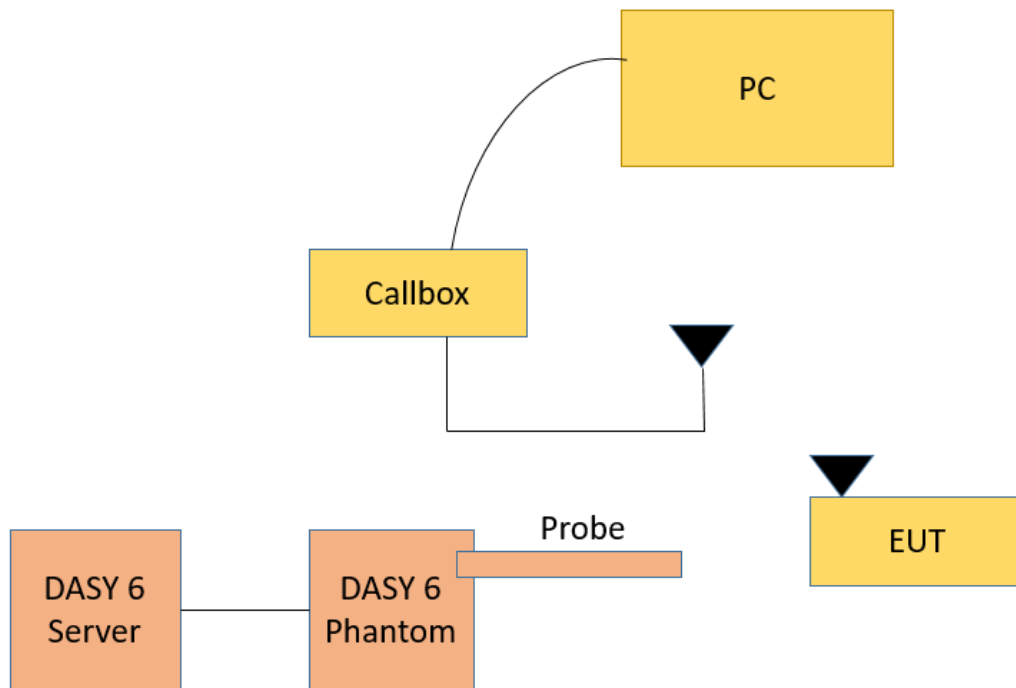

Figure 7-1 TA-SAR wireless test environment

7.2 SAR Measurement Results for Scenario 2: Time-Varying TX power

In this scenario, Mediatek's TA-SAR algorithm is tested under more dynamic power test sequences. The test sequence #1 is shown in section 5.1 and test sequence #2 is tabulated in table 5.4. All of the test cases for this scenario are relegated in Table 7-1, and the test procedure follows section 5.10.2. The measurement setup is shown in Figure 7-1. All of the measurements are conducted by using DASY6. The high-level summary of the final validation results is given in the last column of the table, which concludes that Mediatek's TA-SAR algorithm can maintain the time-averaged SAR is always below the FCC requirement for all test cases. The following sections will demonstrate case-by-case to show how Mediatek's TA-SAR algorithm behaves for each RAT.

Table 7-1 Operating parameters for TA-SAR parameters setting

Test case	RAT	Test band	Test seq.	ECI	Max power (dBm)	P _{sub6_limit} (dBm)	P _{LowThresh} (dBm)	P _{UE_backoff} (dBm)	P _{UE_max_cust} (dBm)	Pass /Fail SAR limit
1	Sub6 NR	38	1	2	22.6	21.6	21.1	18.6	24.6	Pass
2	Sub6 NR	38	2	2	22.6	21.6	21.1	18.6	24.6	Pass
3	Sub6 NR	7	1	4	23.8	14.3	13.8	11.3	17.3	Pass
4	Sub6 NR	7	2	4	23.8	14.3	13.8	11.3	17.3	Pass
5	LTE	4	1	1	23.8	22.3	21.8	19.3	25.3	Pass
6	LTE	4	2	1	23.8	22.3	21.8	19.3	25.3	Pass
7	LTE	7	1	2	23.8	15.3	14.8	12.3	18.3	Pass
8	LTE	7	2	2	23.8	15.3	14.8	12.3	18.3	Pass
9	WCDMA	2	1	1	23.4	22.4	21.9	19.4	25.4	Pass
10	WCDMA	2	2	1	23.4	22.4	21.9	19.4	25.4	Pass
11	WCDMA	4	1	4	23.6	16.1	15.6	13.1	19.1	Pass
12	WCDMA	4	2	4	23.6	16.1	15.6	13.1	19.1	Pass
13	GSM	1900	1	2	29.3	26.3	25.8	23.3	29.3	Pass
14	GSM	1900	2	2	29.3	26.3	25.8	23.3	29.3	Pass
15	GSM	1900	1	4	29.3	25.3	24.8	22.3	28.3	Pass
16	GSM	1900	2	4	29.3	25.3	24.8	22.3	28.3	Pass

7.2.1 SAR Measurement results for NR

- Case 1 in table 7-1: NR n38 result for test sequence 1

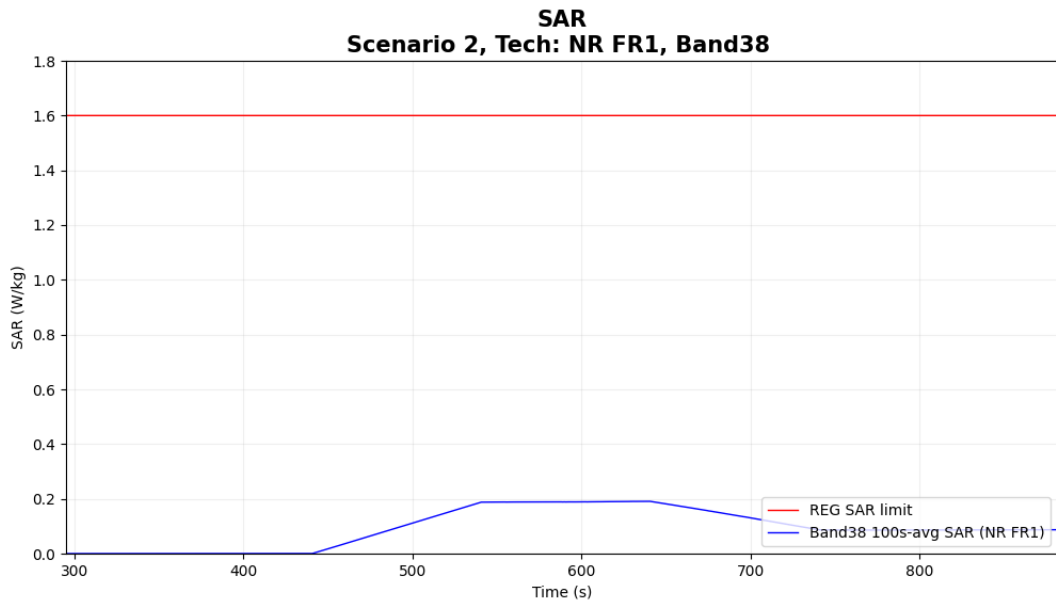

Figure 7-2 Time-averaged SAR for case 1 in table 7-1 (sub NR n38)

FCC 1gSAR limit	1.6 W/kg
Max 100s-time averaged 1gSAR	0.119 W/kg
Validation result: Pass	

- Case 2 in table 7-1: NR n38 result for test sequence 2

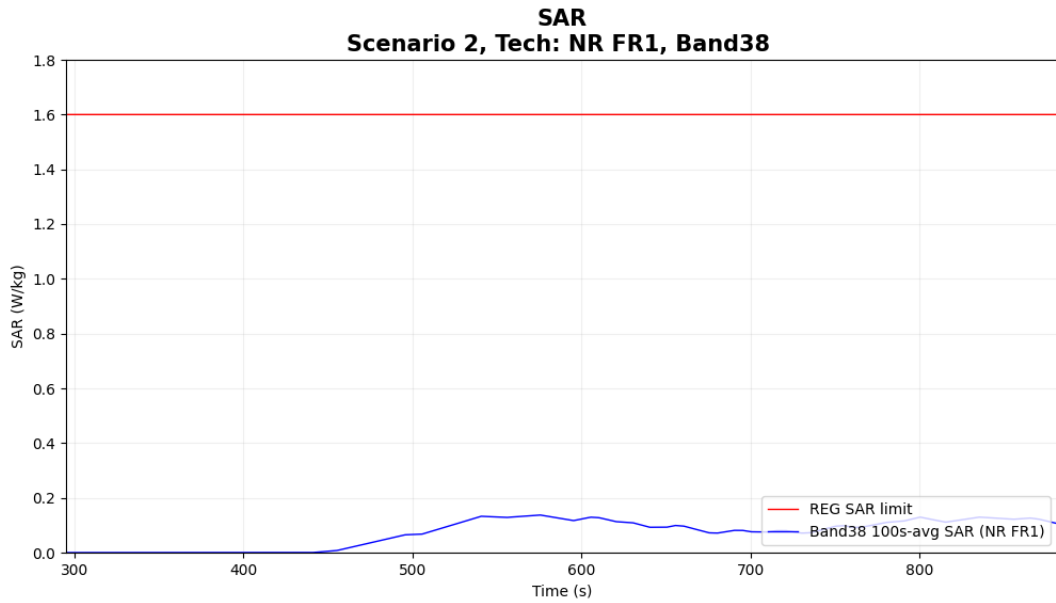

Figure 7-3 Time-averaged SAR for case 2 in table 7-1 (sub NR n38)

FCC 1gSAR limit	1.6 W/kg
Max 100s-time averaged 1gSAR	0.086 W/kg
Validation result: Pass	

- Case 3 in table 7-1: NR n7 result for test sequence 1

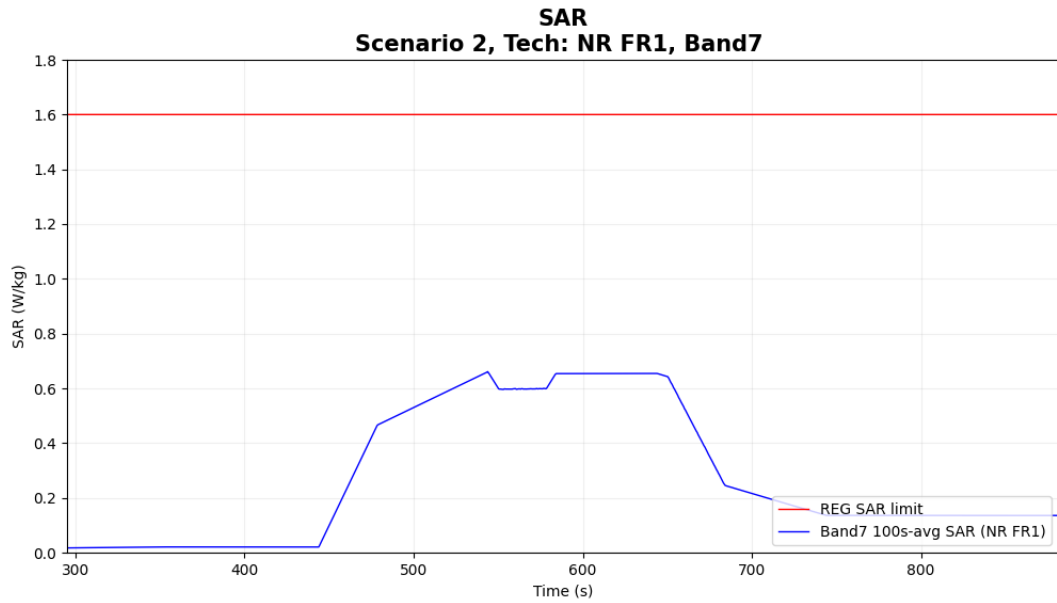

Figure 7-4 Time-averaged SAR for case 3 in table 7-1 (sub NR n7)

FCC 1gSAR limit	1.6 W/kg
Max 100s-time averaged 1gSAR	0.413 W/kg
Validation result: Pass	

- Case 4 in table 7-1: NR n7 result for test sequence 2

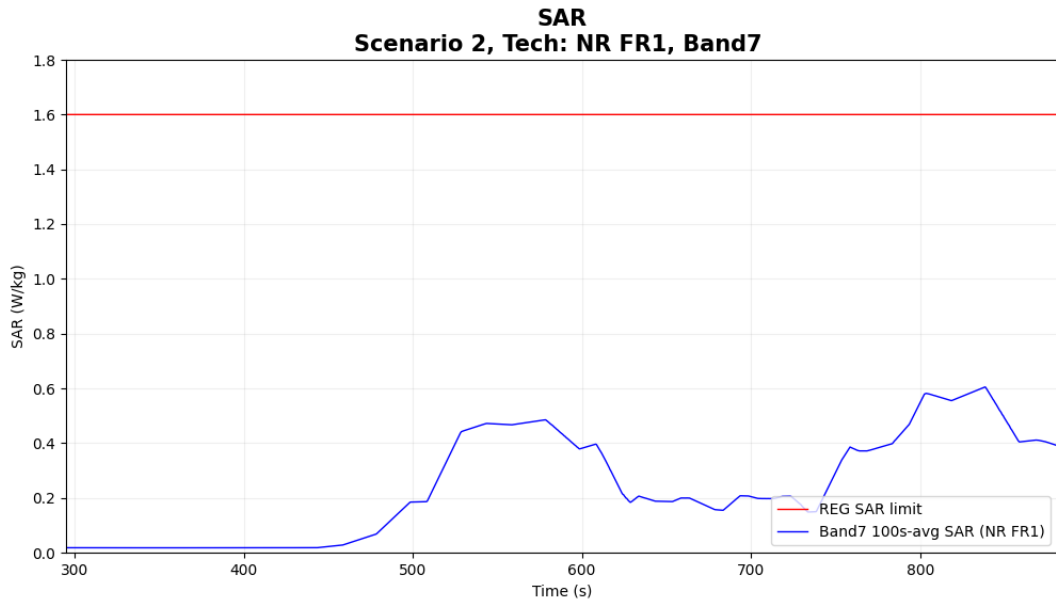

Figure 7-5 Time-averaged SAR for case 4 in table 7-1 (sub NR n7)

FCC 1gSAR limit	1.6 W/kg
Max 100s-time averaged 1gSAR	0.378 W/kg
Validation result: Pass	

7.2.2 SAR Measurement results for 4G LTE

- Case 5 in table 7-1: 4G LTE B4 result for test sequence 1

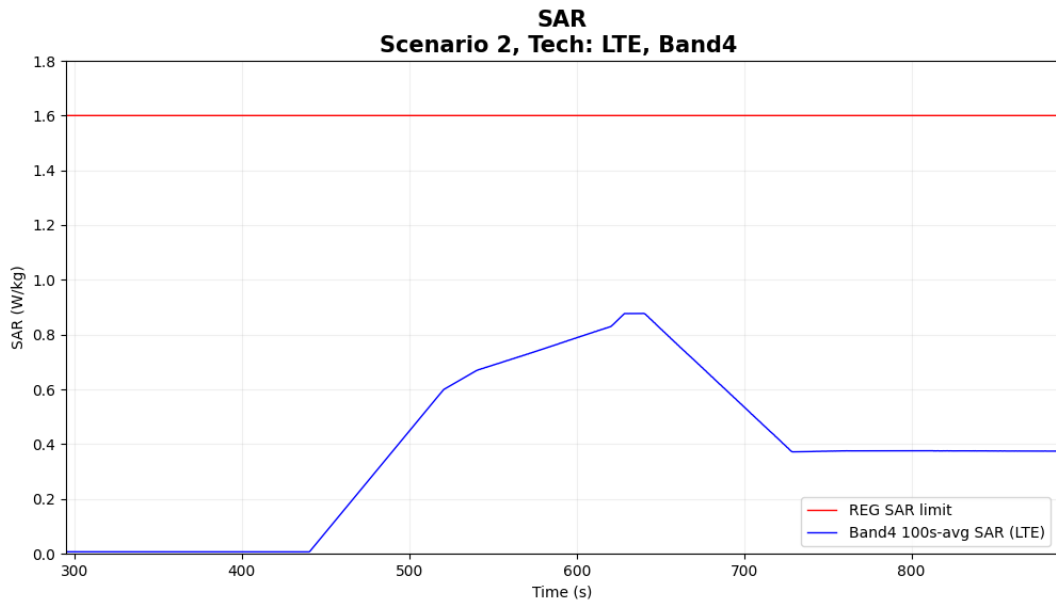

Figure 7-6 Time-averaged SAR for case 5 in table 7-1 (4G LTE B4)

FCC 1gSAR limit	1.6 W/kg
Max 100s-time averaged 1gSAR	0.548 W/kg
Validation result: Pass	

- Case 6 in table 7-1: 4G LTE B4 result for test sequence 2

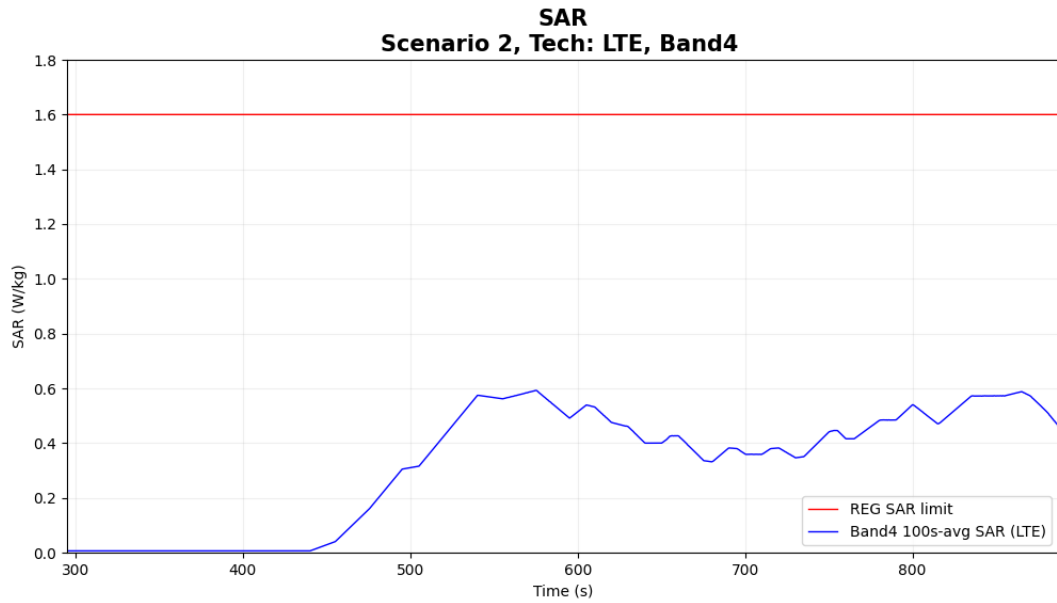

Figure 7-7 Time-averaged SAR for case 6 in table 7-1 (4G LTE B4)

FCC 1gSAR limit	1.6 W/kg
Max 100s-time averaged 1gSAR	0.370 W/kg
Validation result: Pass	

- Case 7 in table 7-1: 4G LTE B7 result for test sequence 1

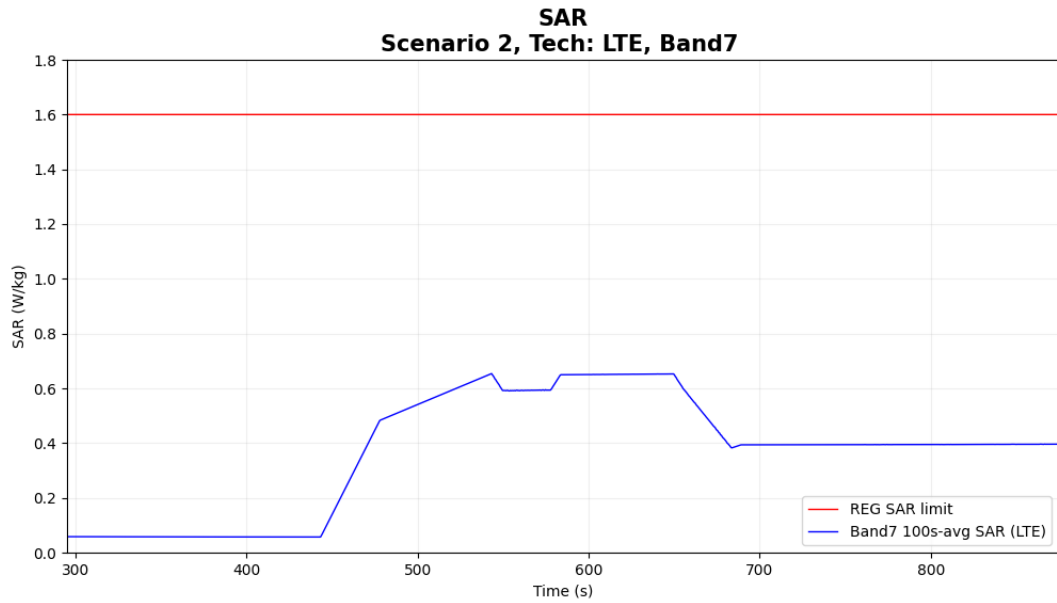

Figure 7-8 Time-averaged SAR for case 7 in table 7-1 (4G LTE B7)

FCC 1gSAR limit	1.6 W/kg
Max 100s-time averaged 1gSAR	0.409 W/kg
Validation result: Pass	

- Case 8 in table 7-1: 4G LTE B7 result for test sequence 2

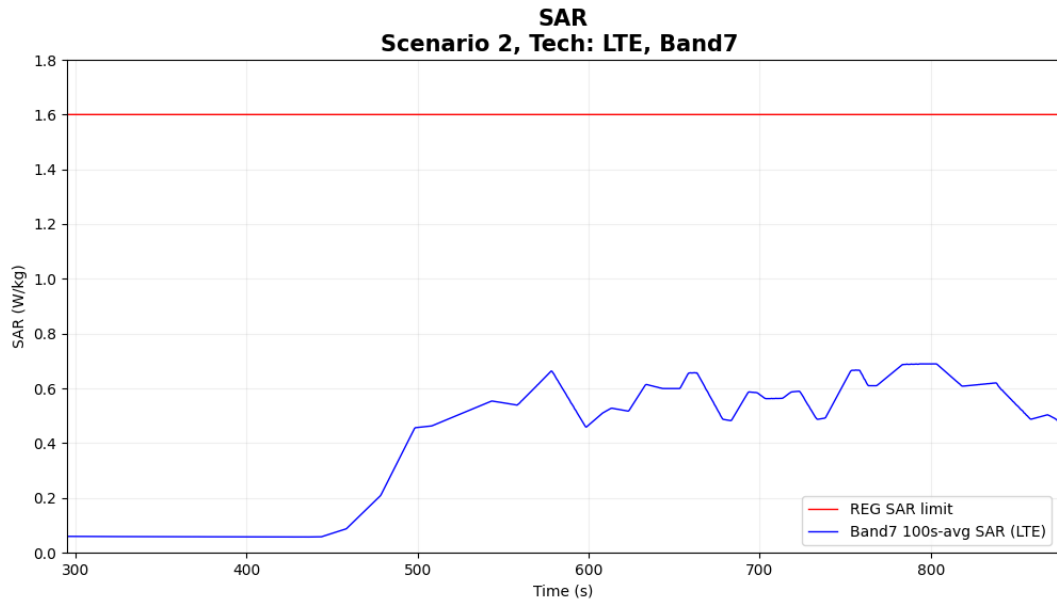

Figure 7-9 Time-averaged SAR for case 8 in table 7-1 (4G LTE B7)

FCC 1gSAR limit	1.6 W/kg
Max 100s-time averaged 1gSAR	0.431 W/kg
Validation result: Pass	

7.2.3 SAR Measurement results for 3G WCDMA

- Case 9 in table 7-1: 3G WCDMA B2 result for test sequence 1

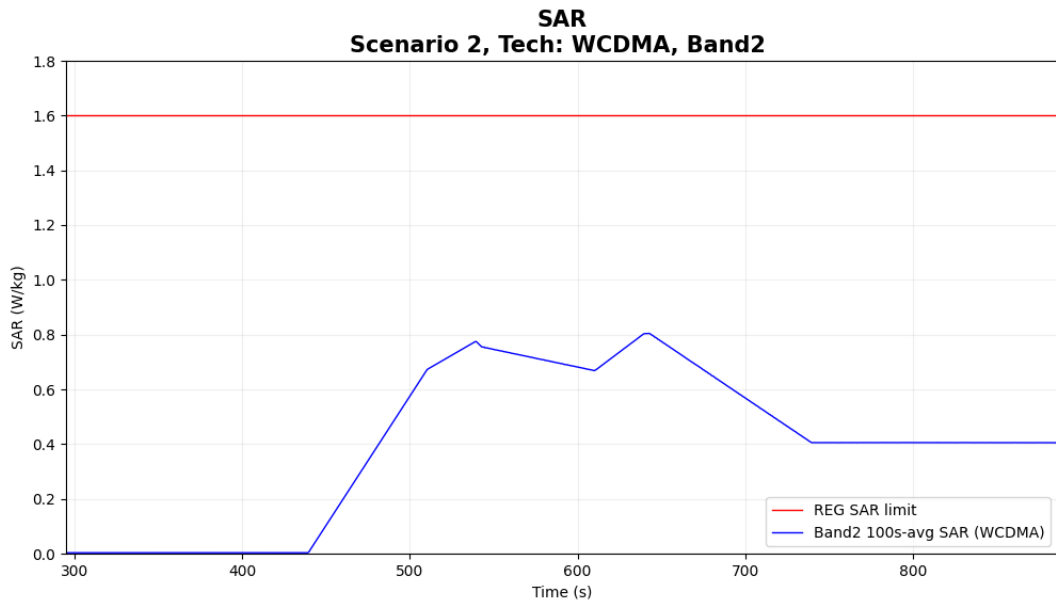

Figure 7-10 Time-averaged SAR for case 9 in table 7-1 (3G WCDMA B2)

FCC 1gSAR limit	1.6 W/kg
Max 100s-time averaged 1gSAR	0.503 W/kg
Validation result: Pass	

- Case 10 in table 7-1: 3G WCDMA B2 result for test sequence 2

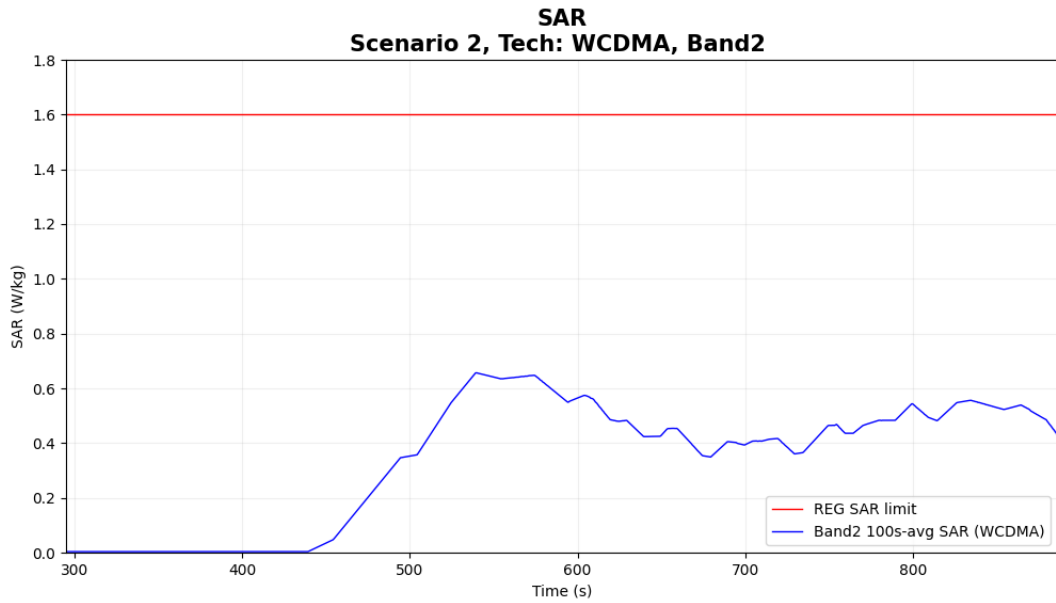

Figure 7-11 Time-averaged SAR for case 10 in table 7-1 (3G WCDMA B2)

FCC 1gSAR limit	1.6 W/kg
Max 100s-time averaged 1gSAR	0.410 W/kg
Validation result: Pass	

- Case 11 in table 7-1: 3G WCDMA B4 result for test sequence 1

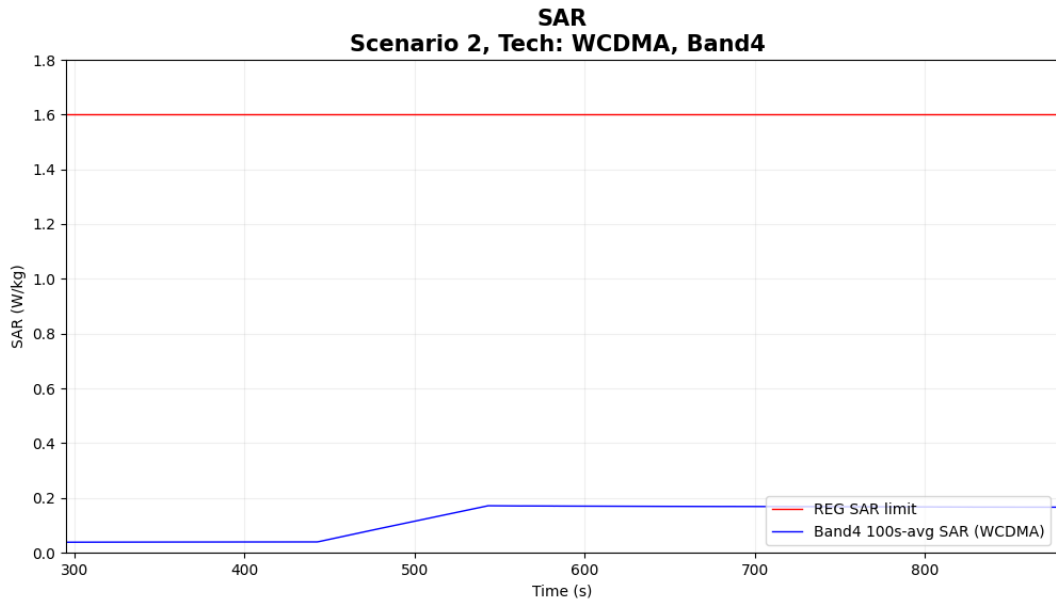

Figure 7-12 Time-averaged SAR for case 11 in table 7-1 (3G WCDMA B4)

FCC 1gSAR limit	1.6 W/kg
Max 100s-time averaged 1gSAR	0.107 W/kg
Validation result: Pass	

- Case 12 in table 7-1: 3G WCDMA B4 result for test sequence 2

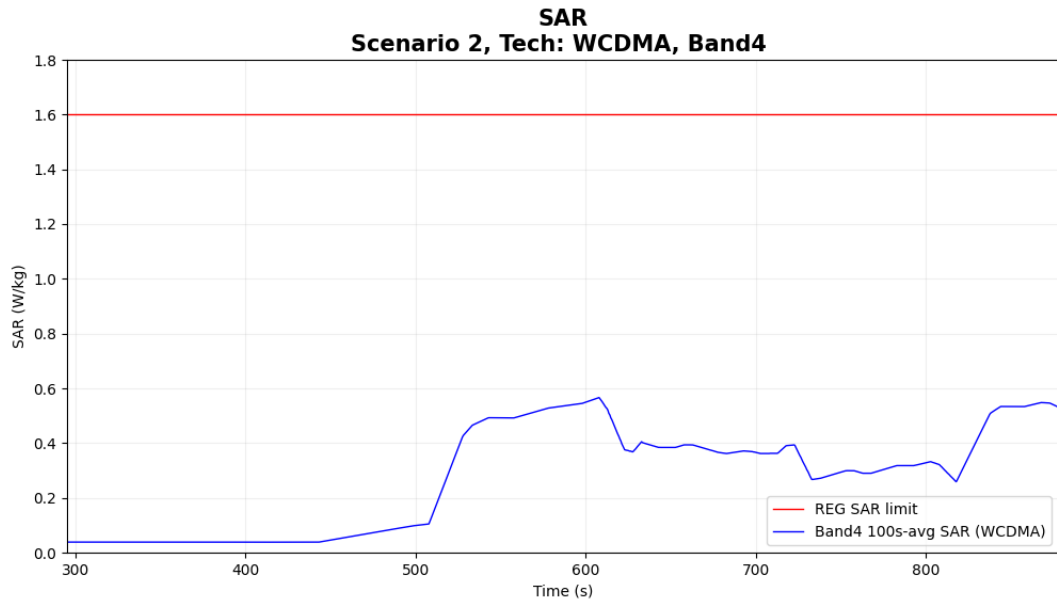

Figure 7-13 Time-averaged SAR for case 12 in table 7-1 (3G WCDMA B4)

FCC 1gSAR limit	1.6 W/kg
Max 100s-time averaged 1gSAR	0.354 W/kg
Validation result: Pass	

7.2.4 SAR Measurement results for 2G GSM

- Case 13 in table 7-1: 2G GSM 1900 result for test sequence 1

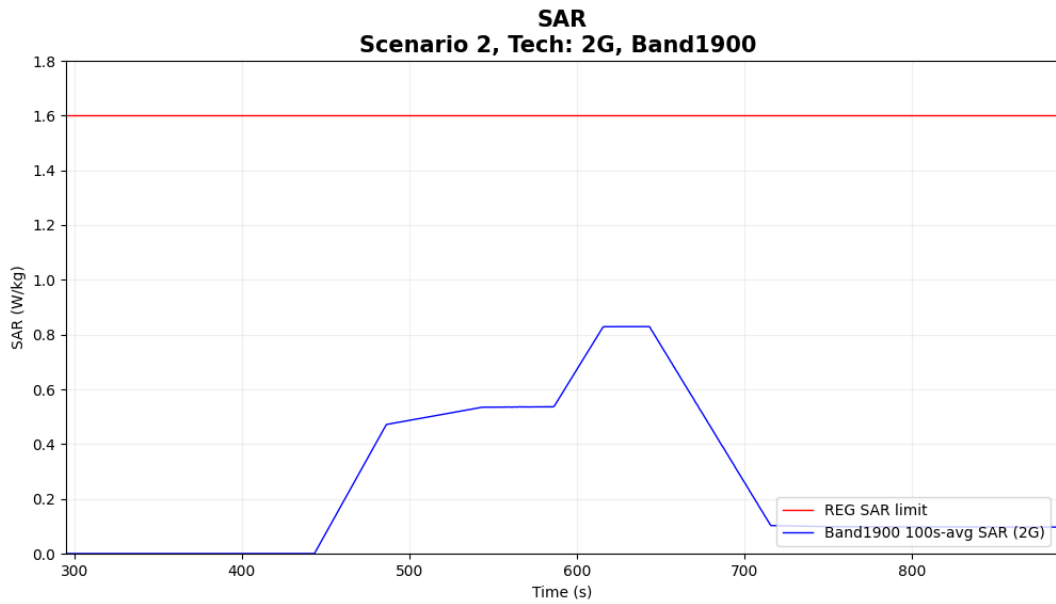

Figure 7-14 Time-averaged SAR for case 13 in table 7-1 (2G GSM 1900)

FCC 1gSAR limit	1.6 W/kg
Max 100s-time averaged 1gSAR	0.518 W/kg
Validation result: Pass	

- Case 14 in table 7-1: 2G GSM 1900 result for test sequence 2

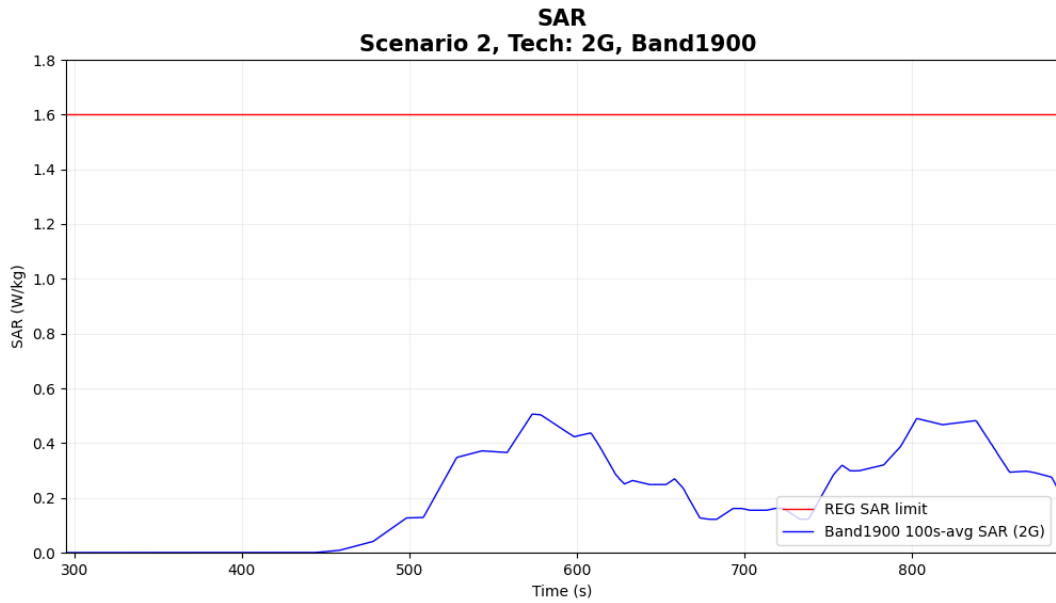

Figure 7-15 Time-averaged SAR for case 14 in table 7-1 (2G GSM 1900)

FCC 1gSAR limit	1.6 W/kg
Max 100s-time averaged 1gSAR	0.316 W/kg
Validation result: Pass	

- Case 15 in table 7-1: 2G GSM 1900 result for test sequence 1

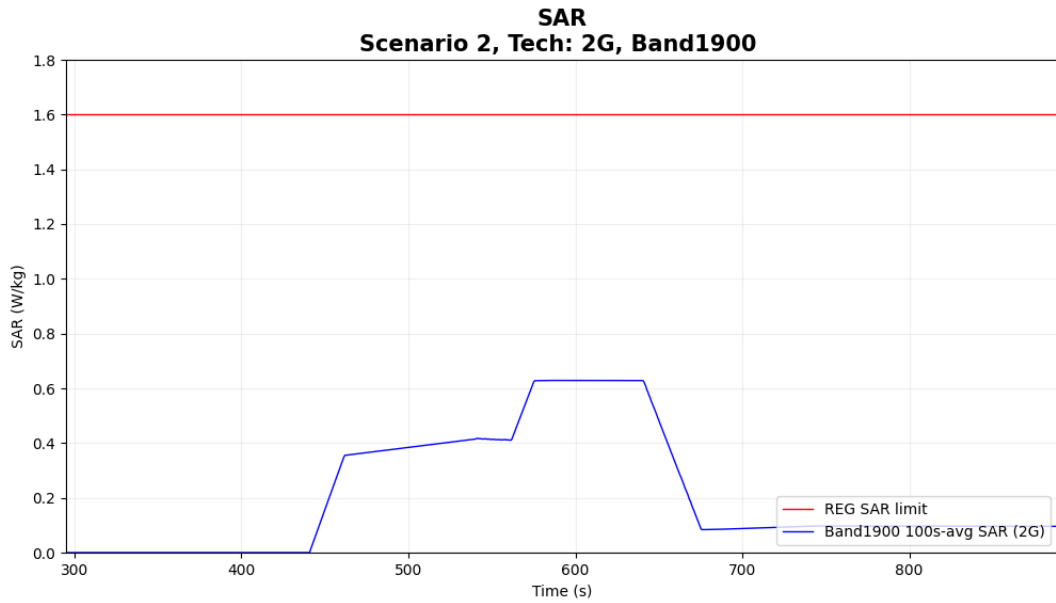

Figure 7-16 Time-averaged SAR for case 15 in table 7-1 (2G GSM 1900)

FCC 1gSAR limit	1.6 W/kg
Max 100s-time averaged 1gSAR	0.393 W/kg
Validation result: Pass	