

# FCC Radio Test Report

## FCC ID: R9C-CPH2185

This report concerns: Original Grant

**Project No.** : 2008C120  
**Equipment** : Mobile Phone  
**Brand Name** : OPPO  
**Test Model** : CPH2185  
**Series Model** : N/A  
**Applicant** : Guangdong OPPO Mobile Telecommunications Corp., Ltd.  
**Address** : NO.18 HaiBin Road, Wusha Village, Chang An Town, DongGuan City, Guangdong,China  
**Manufacturer** : Guangdong OPPO Mobile Telecommunications Corp., Ltd.  
**Address** : NO.18 HaiBin Road, Wusha Village, Chang An Town, DongGuan City, Guangdong,China  
**Factory** : Guangdong OPPO Mobile Telecommunications Corp., Ltd.  
**Address** : NO.18 HaiBin Road, Wusha Village, Chang An Town, DongGuan City, Guangdong,China  
**Date of Receipt** : Aug. 26, 2020  
**Date of Test** : Aug. 26, 2020 ~ Sep. 18, 2020  
**Issued Date** : Sep. 23, 2020  
**Report Version** : R00  
**Test Sample** : Engineering Sample No.: DG2020083153 for conducted, DG2020083151 for radiated.  
**Standard(s)** : 47 CFR FCC Part 90 Subpart S  
47 CFR FCC Part 2  
ANSI/TIA/EIA-603-E-2016  
FCC KDB 971168 D01 Power Meas License Digital Systems v03r01

The above equipment has been tested and found compliance with the requirement of the relative standards by BTL Inc.

*Vegeta Li*

Prepared by : Vegeta Li

*Steven Lu*

Approved by : Steven Lu



Certificate #5123.02

Add: No.3, Jinshagang 1st Road, Shixia, Dalang Town, Dongguan, Guangdong, China.

Tel: +86-769-8318-3000

Web: www.newbtl.com

**Declaration**

**BTL** represents to the client that testing is done in accordance with standard procedures as applicable and that test instruments used has been calibrated with standards traceable to international standard(s) and/or national standard(s).

**BTL's** reports apply only to the specific samples tested under conditions. It is manufacture's responsibility to ensure that additional production units of this model are manufactured with the identical electrical and mechanical components. **BTL** shall have no liability for any declarations, inferences or generalizations drawn by the client or others from **BTL** issued reports.

The report must not be used by the client to claim product certification, approval, or endorsement by NIST, A2LA, or any agency of the U.S. Government.

This report is the confidential property of the client. As a mutual protection to the clients, the public and ourselves, the test report shall not be reproduced, except in full, without our written approval.

**BTL's** laboratory quality assurance procedures are in compliance with the **ISO/IEC 17025** requirements, and accredited by the conformity assessment authorities listed in this test report.

**BTL** is not responsible for the sampling stage, so the results only apply to the sample as received.

The information, data and test plan are provided by manufacturer which may affect the validity of results, so it is manufacturer's responsibility to ensure that the apparatus meets the essential requirements of applied standards and in all the possible configurations as representative of its intended use.

**Limitation**

For the use of the authority's logo is limited unless the Test Standard(s)/Scope(s)/Item(s) mentioned in this test report is (are) included in the conformity assessment authorities acceptance respective.

Please note that the measurement uncertainty is provided for informational purpose only and is not use in determining the Pass/Fail results.

<b>Table of Contents</b>	<b>Page</b>
<b>REPORT ISSUED HISTORY</b>	<b>5</b>
<b>1 . SUMMARY OF TEST RESULTS</b>	<b>6</b>
1.1 TEST FACILITY	7
1.2 MEASUREMENT UNCERTAINTY	7
1.3 TEST ENVIRONMENT CONDITIONS	8
<b>2 . GENERAL INFORMATION</b>	<b>9</b>
2.1 GENERAL DESCRIPTION OF EUT	9
2.2 DESCRIPTION OF TEST MODES	11
2.3 BLOCK DIGRAM SHOWING THE CONFIGURATIONOFSYSTEMTESTED	12
3.4 DESCRIPTION OF SUPPORT UNITS	12
<b>3 . TEST RESULT</b>	<b>13</b>
3.1 OUTPUT POWER MEASUREMENT	13
3.1.1 LIMIT	13
3.1.2 TEST PROCEDURE	13
3.1.3 TESTSETUP LAYOUT	13
3.1.4 TEST DEVIATION	13
3.1.5 TEST RESULTS	13
3.2 OCCUPIED BANDWIDTH MEASUREMENT	14
3.2.1 TEST PROCEDURE	14
3.2.2 TEST SETUP LAYOUT	14
3.2.3 TEST DEVIATION	14
3.2.4 TEST RESULTS	14
3.3 CONDUCTED SPURIOUS EMISSIONS MEASUREMENT	15
3.3.1 LIMIT	15
3.3.2 TEST PROCEDURES	15
3.3.3 TESTSETUP LAYOUT	15
3.3.4 TESTDEVIATION	15
3.3.5 TEST RESULTS	15
3.4 RADIATED SPURIOUS EMISSIONS MEASUREMENT	16
3.4.1 LIMIT	16
3.4.2 TEST PROCEDURES	16
3.4.3 TEST SETUP LAYOUT	17
3.4.4 TESTDEVIATION	18
3.4.5 TEST RESULTS (9KHZ TO 30MHZ)	18
3.4.6 TEST RESULTS (30MHZ TO 1000MHZ)	18
3.4.7 TEST RESULTS (ABOVE 1000MHZ)	18
3.5 MASK MEASUREMENTS	19
3.5.1 LIMIT	19

<b>Table of Contents</b>	<b>Page</b>
3.5.2 TEST PROCEDURES	19
3.5.3 TESTSETUP LAYOUT	19
3.5.4 TESTDEVIATION	19
3.5.5 TEST RESULTS	19
3.6 PEAK TO AVERAGE RATIO MEASUREMENT	20
3.6.1 LIMIT	20
3.6.2 TEST PROCEDURES	20
3.6.3 TEST SETUP LAYOUT	20
3.6.4 TEST DEVIATION	20
3.6.5 TEST RESULTS	20
3.7 FREQUENCY STABILITY MEASUREMENT	21
3.7.1 LIMIT	21
3.7.2 TEST PROCEDURES	21
3.7.3 TESTSETUP LAYOUT	21
3.7.4 TESTDEVIATION	21
3.7.5 TEST RESULTS	21
5. LIST OF MEASUREMENT EQUIPMENTS	22
APPENDIX A - OUTPUT POWER	24
APPENDIX B - OCCUPIED BANDWIDTH	29
APPENDIX C - CONDUCTED SPURIOUS EMISSIONS	40
APPENDIX D - RADIATED SPURIOUS EMISSIONS (9KHZ TO 30MHZ)	44
APPENDIX E - RADIATED SPURIOUS EMISSIONS (30MHZ TO 1000MHZ)	49
APPENDIX F - RADIATED SPURIOUS EMISSIONS (ABOVE 1000MHZ)	62
APPENDIX G - MASK	75
APPENDIX H - PEAK TO AVERAGE RATIO	80
APPENDIX I - FREQUENCY STABILITY	88

**REPORT ISSUED HISTORY**

Report Version	Description	Issued Date
R00	Original Issue.	Sep. 23, 2020

## 1. SUMMARY OF TEST RESULTS

Test procedures according to the technical standard(s):

FCC Part 90 Subpart S & Part 2			
Standard(s) Section	Test Item	Judgment	Remark
2.1046 & 90.635 (b)	Effective Radiated Power	PASS	-----
2.1049 & 90.209	Occupied Bandwidth	PASS	-----
2.1053 & 90.669	Conducted Spurious Emissions	PASS	-----
2.1053 & 90.669	Radiated Spurious Emissions	PASS	-----
2.1053 & 90.691	Mask Measurements	PASS	-----
-	Peak To Average Ratio	PASS	Record Only
2.1055 & 90.213	Frequency Stability	PASS	-----

Note:

(1) "N/A" denotes test is not applicable in this test report.

## 1.1 TEST FACILITY

The test facilities used to collect the test data in this report is at the location of No.3, Jinshagang 1st Road, Shixia, Dalang Town, Dongguan, Guangdong, China.

BTL's Test Firm Registration Number for FCC: 357015

BTL's Designation Number for FCC: CN1240

## 1.2 MEASUREMENT UNCERTAINTY

ISO/IEC 17025 requires that an estimate of the measurement uncertainties associated with the emissions test results be included in the report. The measurement uncertainties given below are based on a 95% confidence level (based on a coverage factor ( $k=2$ ))

The BTL measurement uncertainty as below table:

### A. Radiated Measurement :

Test Site	Method	Measurement Frequency Range	Ant. H / V	U,(dB)
DG-CB03 (3m)	CISPR	9KHz ~ 30MHz	V	3.79
		9KHz ~ 30MHz	H	3.57
		30MHz ~ 200MHz	V	4.88
		30MHz ~ 200MHz	H	4.14
		200MHz ~ 1,000MHz	V	4.62
		200MHz ~ 1,000MHz	H	4.80

Test Site	Method	Measurement Frequency Range	U,(dB)
DG-CB03 (3m)	CISPR	1GHz ~ 6GHz	4.58
		6GHz ~ 18GHz	5.18

### B. Other Measurement:

Parameter	Uncertainty
Spectrum Bandwidth	±3.8 %
Maximum Output Power	±0.95 dB
Power Spectral Density	±0.86 dB
Frequency Stability	±0.16 dB
Temperature	±0.08 °C
Time	±0.58 %
Supply voltages	±0.3 %

Note: Unless specifically mentioned, the uncertainty of measurement has not been taken into account to declare the compliance or non-compliance to the specification.

**1.3 TEST ENVIRONMENT CONDITIONS**

Test Item	Temperature	Humidity	Test Voltage	Tested By
Output Power & ERP	23.9°C	46%	DC 3.85V	Tate Liu
Occupied Bandwidth	23.9°C	46%	DC 3.85V	Tate Liu
Conducted Spurious Emissions	23.9°C	46%	DC 3.85V	Tim Yang
Radiated Spurious Emissions	26°C	52%	AC 120V/60Hz	Jakyri Wen
Band Edge	23.9°C	46%	DC 3.85V	Tate Liu
Peak to Average Ratio	23.9°C	46%	DC 3.85V	Tate Liu
Frequency Stability	Normal & Extreme	46%	Normal & Extreme	Tate Liu



## 2. GENERAL INFORMATION

### 2.1 GENERAL DESCRIPTION OF EUT

Equipment	Mobile Phone				
Brand Name	OPPO				
Test Model	CPH2185				
Series Model	N/A				
Model Difference(s)	N/A				
Hardware Version	11				
Software Version	Color OS V7.2				
Power Source	1. DC Voltage supplied from AC adapter. 1# Model: OP52YAUH 2# Model: OP52JAUH 3# Model: OP52KAUH 4# Model: OP52JBUH 2. Supplied from Li-ion Polymer battery. Model: BLP817 3. Supplied from USB port.				
Power Rating	1. I/P: 100-240V~ 50/60Hz 0.4A O/P: 5V --- 2A 2. 3.85Vdc, 4100mAh/15.78Wh 3. DC 5V				
IEMI No.	Radiated	866261050019950			
	Conducted	866261050019919			
Modulation Type	LTE	UL: QPSK, 16QAM, 64QAM DL: QPSK, 16QAM, 64QAM			
Max. ERP	LTE	Channel Bandwidth (MHz)	QPSK (dBm)	16QAM (dBm)	64QAM (dBm)
		1.4	21.51	20.83	19.94
	Band 26	3	21.57	20.92	19.92
		5	21.52	20.92	19.83
		10	21.59	20.91	19.77

Note:

1. For a more detailed features description, please refer to the manufacturer's specifications or the user's manual.

2. Channel List:

LTE Band 26					
Test Frequency ID	Bandwidth (MHz)	N <sub>UL</sub>	Frequency of Uplink (MHz)	N <sub>DL</sub>	Frequency of Downlink (MHz)
Low Range	1.4	26697	814.7	8697	859.7
	3	26705	815.5	8705	860.5
	5	26715	816.5	8715	861.5
Mid Range	1.4/3/5/10	26740	819	8740	864
High Range	1.4	26783	823.3	8783	868.3
	3	26775	822.5	8775	867.5
	5	26765	821.5	8765	866.5

## 3. Table for Filed Antenna:

## Main Antenna

Brand	Model Name	Antenna Type	Connector	Gain (dBi)	Note
N/A	N/A	PIFA	N/A	0.5	LTE Band 26

## Second Antenna

Brand	Model Name	Antenna Type	Connector	Gain (dBi)	Note
N/A	N/A	PIFA	N/A	0.5	LTE Band 26

## 2.2 DESCRIPTION OF TEST MODES

Following mode(s) is (were) found to be the worst case(s) and selected for the final test.

LTE BAND 26 MODE					
Test Item	Available Channel	Tested Channel	Channel Bandwidth	Modulation	Mode
Output Power & ERP	26697 to 26783	26697, 26740, 26783	1.4MHz	QPSK, 16QAM, 64QAM	1RB/3RB/6RB
	26705 to 26775	26705, 26740, 26775	3MHz	QPSK, 16QAM, 64QAM	1RB/8RB/15RB
	26715 to 26765	26715, 26740, 26765	5MHz	QPSK, 16QAM, 64QAM	1RB/12RB/25RB
	26740	26740	10MHz	QPSK, 16QAM, 64QAM	1RB/25RB/50RB
Occupied Bandwidth	26697 to 26783	26697, 26740, 26783	1.4MHz	QPSK, 16QAM, 64QAM	6RB
	26705 to 26775	26705, 26740, 26775	3MHz	QPSK, 16QAM, 64QAM	15RB
	26715 to 26765	26715, 26740, 26765	5MHz	QPSK, 16QAM, 64QAM	25RB
	26740	26740	10MHz	QPSK, 16QAM, 64QAM	1RB/25RB/50RB
Conducted Spurious Emissions	26697 to 26783	26740	1.4MHz	QPSK	1RB
	26705 to 26775	26740	5MHz	QPSK	1RB
	26715 to 26765	26740	10MHz	QPSK	1RB
Radiated Spurious Emissions	26697 to 26783	26740	1.4MHz	QPSK	1RB
	26705 to 26775	26740	5MHz	QPSK	1RB
	26715 to 26765	26740	10MHz	QPSK	1RB
Mask	26697 to 26783	26697, 26783	1.4MHz	QPSK	1RB 6RB
	26705 to 26775	26705, 26775	3MHz	QPSK	1RB 15RB
	26715 to 26765	26715, 26765	5MHz	QPSK	1RB 25RB
	26740	26740	10MHz	QPSK	1RB 50RB
Peak To Average Ratio	26697 to 26783	26697, 26740, 26783	1.4MHz	QPSK, 16QAM, 64QAM	1RB
	26705 to 26775	26705, 26740, 26775	3MHz	QPSK, 16QAM, 64QAM	1RB
	26715 to 26765	26715, 26740, 26765	5MHz	QPSK, 16QAM, 64QAM	1RB
	26740	26740	10MHz	QPSK, 16QAM, 64QAM	1RB
Frequency Stability	26697 to 26783	26740	1.4MHz	QPSK	1RB
	26705 to 26775	26740	3MHz	QPSK	1RB
	26715 to 26765	26740	5MHz	QPSK	1RB
	26740	26740	10MHz	QPSK	1RB

### 2.3 BLOCK DIGRAM SHOWING THE CONFIGURATION OF SYSTEM TESTED

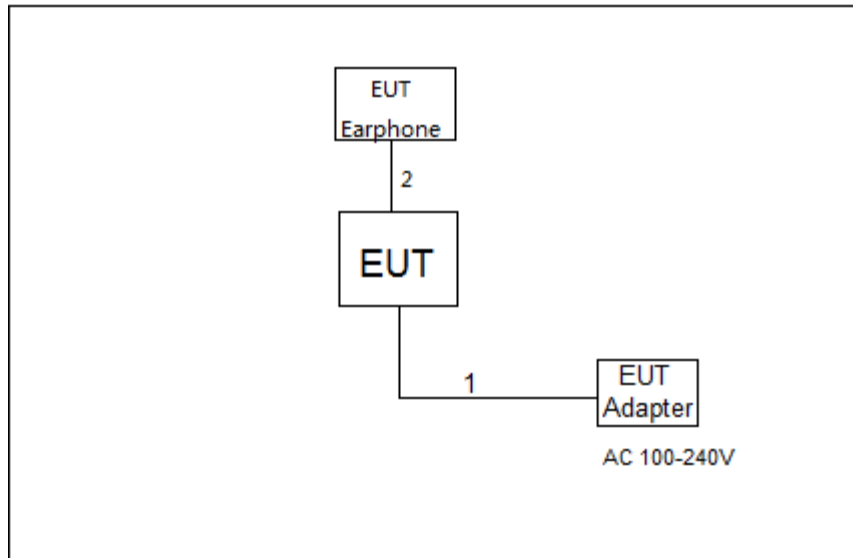

### 3.4 DESCRIPTION OF SUPPORT UNITS

The EUT has been tested as an independent unit together with other necessary accessories or support units. The following support units or accessories were used to form a representative test configuration during the tests.

Item	Equipment	Mfr/Brand	Model/Type No.	Series No.
-	-	-	-	-

Item	Cable Type	Shielded Type	Ferrite Core	Length
1	USB Cable	YES	NO	1m
2	Audio Cable	NO	NO	1m

### 3. TEST RESULT

#### 3.1 OUTPUT POWER MEASUREMENT

##### 3.1.1 LIMIT

Mobile / Portable station are limited to 100 watts e.r.p.

##### 3.1.2 TEST PROCEDURE

The testing follows FCC KDB 971168 v03r01 Section 5.0.

##### ERP:

$EIRP = \text{Output Power} + \text{Antenan gain}$

$ERP = EIPR - 2.15\text{dBi}$ .

##### Output Power:

The EUT was set up for the maximum power with GSM, GPRS, EDGE, WCDMA, CDMA, and LTE link data modulation and link up with simulator. Set the EUT to transmit under low, middle and high channel and record the power level shown on simulator.

##### 3.1.3 TESTSETUP LAYOUT

###### Output Power Measurement



##### 3.1.4 TEST DEVIATION

No deviation

##### 3.1.5 TEST RESULTS

Please refer to the APPENDIX A.

## 3.2 OCCUPIED BANDWIDTH MEASUREMENT

### 3.2.1 TEST PROCEDURE

The testing follows FCC KDB 971168 v03r01 Section 4.0.

1. The EUT makes a call to the communication simulator. All measurements were done at low, middle and high operational frequency range. The communication simulator station system controlled a EUT to export maximum output power under transmission mode and specific channel frequency. Use OBW measurement function of Spectrum analyzer to measure 99 % occupied bandwidth and 26dB bandwidth.
2. The EUT was connected to spectrum analyzer and system simulator via a power divider.
3.  $RBW=(1\% \sim 5\%)*EBW$   
 $VBW \geq 3* RBW$
4. Set spectrum analyzer with RMS detector.

### 3.2.2 TEST SETUP LAYOUT

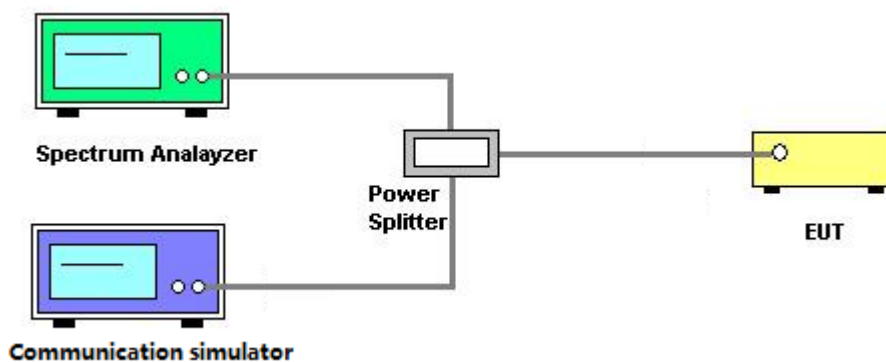

### 3.2.3 TEST DEVIATION

No deviation

### 3.2.4 TEST RESULTS

Please refer to the APPENDIX B.

### 3.3 CONDUCTED SPURIOUS EMISSIONS MEASUREMENT

#### 3.3.1 LIMIT

The power of any emission outside of the authorized operating frequency ranges must be attenuated below the transmitting power (P) by a factor of at least  $43 + 10 \log(P)$  dB. The emission limit equal to -13dBm.

#### 3.3.2 TEST PROCEDURES

The testing follows FCC KDB 971168 v03r01 Section 6.0.

1. The EUT was connected to spectrum analyzer and system simulator via a power divider.
2. The band edges of low and high channels for the highest RF powers were measured. Set  $RBW \geq 1\%$  EBW in the 1MHz band immediately outside and adjacent to the band edge.
3. Set spectrum analyzer with RMS detector.
4. The RF fundamental frequency should be excluded against the limit line in the operating frequency band.

#### 3.3.3 TESTSETUP LAYOUT

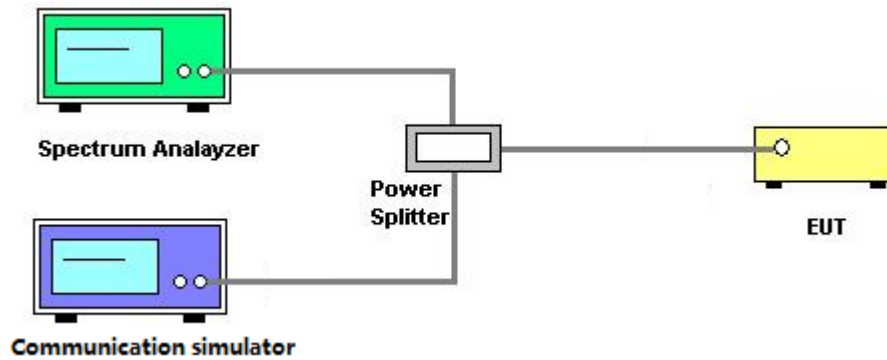

#### 3.3.4 TESTDEVIATION

No deviation

#### 3.3.5 TEST RESULTS

Please refer to the APPENDIX C.

### **3.4 RADIATED SPURIOUS EMISSIONS MEASUREMENT**

#### **3.4.1 LIMIT**

The power of any emission outside of the authorized operating frequency ranges must be attenuated below the transmitting power (P) by a factor of at least  $43 + 10 \log(P)$  dB. The emission limit equal to -13dBm.

#### **3.4.2 TEST PROCEDURES**

The testing follows FCC KDB 971168 v03r01 Section 5.8.

1. In the semi-anechoic chamber, EUT placed on the 0.8m height of Turn Table, rotated the table around 360 degrees to search the maximum radiation power and receiver antenna shall be rotated vertical and horizontal polarization and moved height from 1m to 4m to find the maximum polar radiated power. The "Read Value" is the spectrum reading the maximum power value.
2. The substitution horn antenna is substituted for EUT at the same position and signals generator export the CW signal to the substitution antenna via a TX cable. Rotated the Turn Table and moved receiving antenna to find the maximum radiation power. Adjust output power level of S.G to get a Value of spectrum reading equal to "Read Value " of step a. Record the power level of S.G
3.  $EIRP = \text{Output power level of S.G} - \text{TX cable loss} + \text{Antenna gain of substitution horn.}$
4. ERP can be calculated form EIRP by subtracting the gain of dipole,  $ERP = EIPR - 2.15\text{dBi.}$
5. The resolution bandwidth and video bandwidth of test receiver/spectrum analyzer is 1MHz/3MHz.

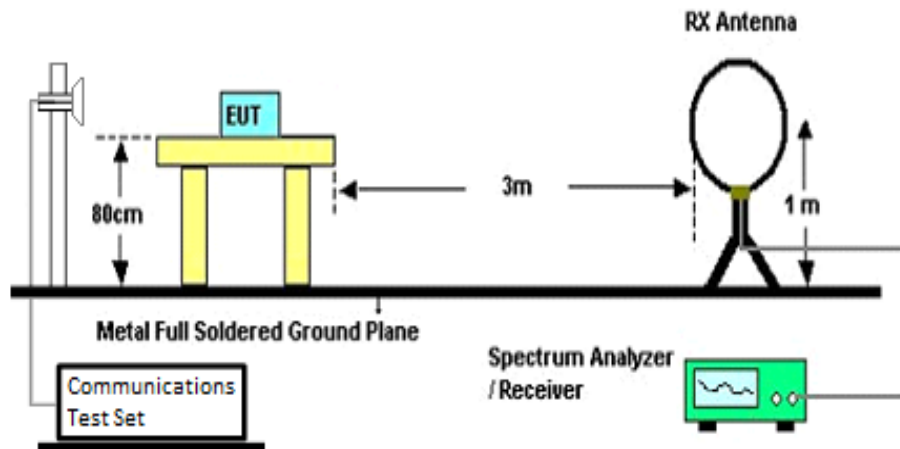
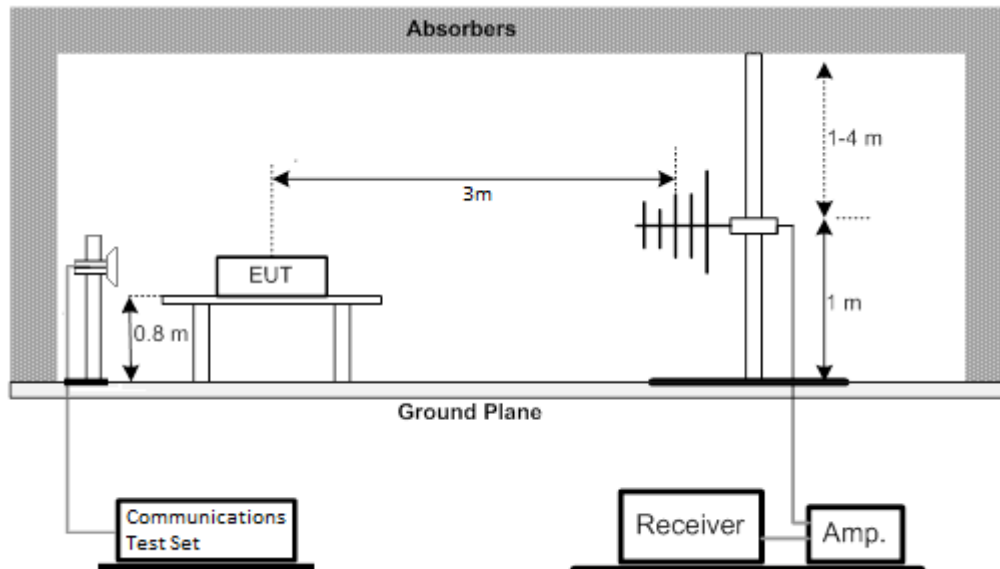

**3.4.3 TEST SETUP LAYOUT****Below 30MHz****30MHz to 1000MHz**

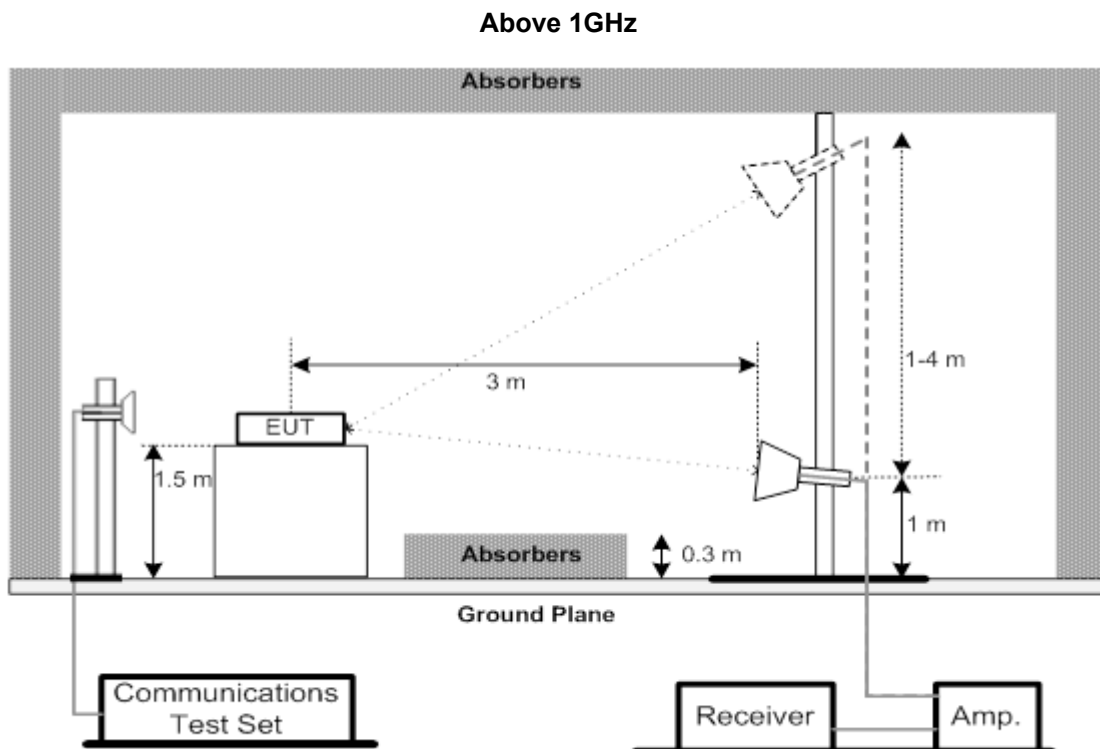

#### 3.4.4 TEST DEVIATION

No deviation

#### 3.4.5 TEST RESULTS (9KHZ TO 30MHZ)

Please refer to the APPENDIX D.

#### 3.4.6 TEST RESULTS (30MHZ TO 1000MHZ)

Please refer to the APPENDIX E.

#### 3.4.7 TEST RESULTS (ABOVE 1000MHZ)

Please refer to the APPENDIX F.

### 3.5 MASK MEASUREMENTS

#### 3.5.1 LIMIT

According to FCC part 90.691 shall be tested the emission mask. For any frequency removed from the EA licensee's frequency block by up to and including 37.5 kHz, the power of any emission shall be attenuated below the transmitter power (P) in watts by at least  $116 \text{ Log}_{10}(f/6.1)$  decibels or  $50+10\text{Log}_{10}(P)$  decibels or 80 decibels, whichever is the lesser attenuation, where f is the frequency removed from the center of the outer channel in the block in kilohertz and where f is greater than 12.5 kHz. For any frequency removed from the EA licensee's frequency block greater than 37.5 kHz, the power of any emission shall be attenuated below the transmitter power (P) in watts by at least  $43 + 10\text{Log}_{10}(P)$  decibels or 80 decibels, whichever is the lesser attenuation, where f is the frequency removed from the center of the outer channel in the block in kilohertz and where f is greater than 37.5 kHz.

#### 3.5.2 TEST PROCEDURES

The testing follows FCC KDB 971168 v03r01 Section 6.0.

1. All measurements were done at low and high operational frequency range.
2. Set RBW=1% of 26dBc bandwidth, VBW=3 X RBW, detector=RMS, Sweep time = Auto.  
For Section 90.691(a) compliance testing, use RBW = 300 Hz for offsets less than 37.5 kHz from a channel edge; RBW = 100 kHz for offsets greater than 37.5 kHz is allowed.
3. Record the max trace plot into the test report.

#### 3.5.3 TESTSETUP LAYOUT

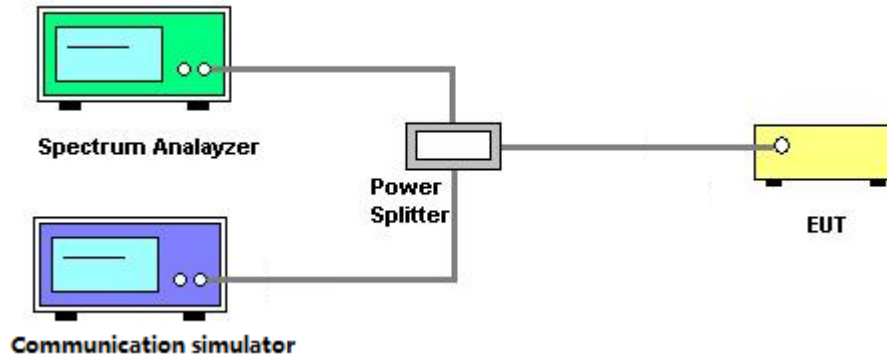

#### 3.5.4 TESTDEVIATION

No deviation

#### 3.5.5 TEST RESULTS

Please refer to the APPENDIX G.

### 3.6 PEAK TO AVERAGE RATIO MEASUREMENT

#### 3.6.1 LIMIT

In measuring transmissions in this band using an average power technique, the peak to-average ratio (PAR) of the transmission may not exceed 13 dB.

#### 3.6.2 TEST PROCEDURES

The testing follows FCC KDB 971168 v03r01 Section 5.7.

1. Set resolution/measurement bandwidth  $\geq$  signal's occupied bandwidth;
2. Set the number of counts to a value that stabilizes the measured CCDF curve;
3. Record the maximum PAPR level associated with a probability of 0.1%.

#### 3.6.3 TEST SETUP LAYOUT

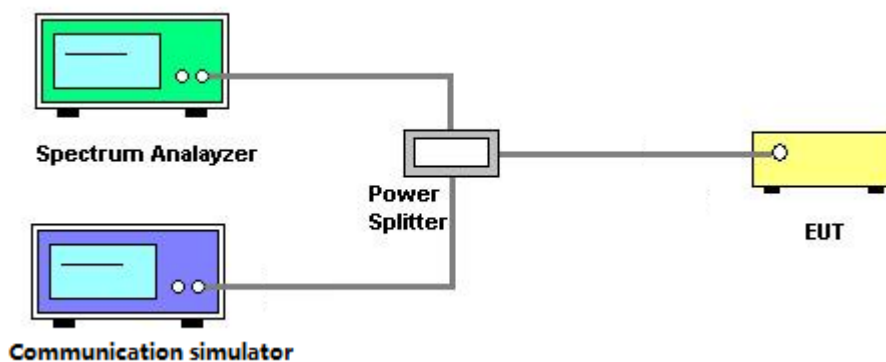

#### 3.6.4 TEST DEVIATION

No deviation

#### 3.6.5 TEST RESULTS

Please refer to the APPENDIX H.

### 3.7 FREQUENCY STABILITY MEASUREMENT

#### 3.7.1 LIMIT

$\pm 1.5$  ppm is for base and fixed station.  $\pm 2.5$  ppm is for mobile station.

#### 3.7.2 TEST PROCEDURES

The testing follows FCC KDB 971168 v03r01 Section 9.0.

1. Device is placed at the oven room. The oven room could control the temperatures and humidity. Power warm up is at least 15 min and power applied should perform before recording frequency error.
2. EUT is connected the external power supply to control the DC input power. The test voltage range is from minimum to maximum working voltage. Each step shall be record the frequency error rate.
3. The temperature range step is 10 degrees in this test items. All temperature levels shall be hold the  $\pm 0.5^{\circ}\text{C}$  during the measurement testing. The each temperature step shall be at least 0.5 hours, consider the EUT could be test under the stability condition.
4. The frequency error was recorded frequency error from the communication simulator.

#### 3.7.3 TESTSETUP LAYOUT

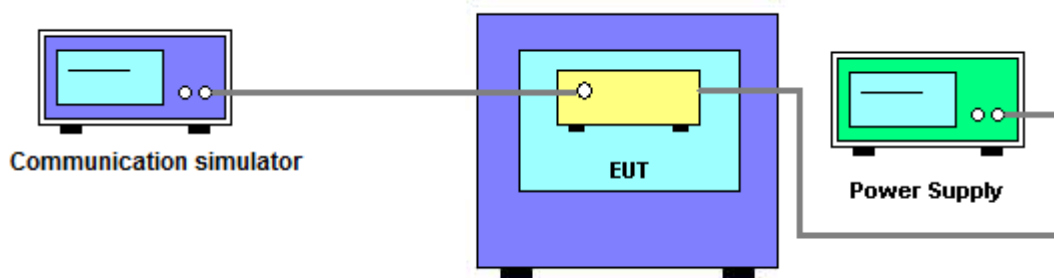

#### 3.7.4 TESTDEVIATION

No deviation

#### 3.7.5 TEST RESULTS

Please refer to the APPENDIX I.

## 5. LIST OF MEASUREMENT EQUIPMENTS

Radiated Spurious Emission Measurement					
Item	Kind of Equipment	Manufacturer	Type No.	Serial No.	Calibrated until
1	Antenna	Schwarzbeck	VULB9160	9160-3232	Mar. 09, 2021
2	Amplifier	Agilent	8449B	3008A02334	Mar. 01, 2021
3	HighPass Filter	Wairwright Instruments Gmbh	WHK 1.5/15G-10ST	11	Feb. 28, 2021
4	Band Reject Filter	Wairwright Instruments Gmbh	WRCG 1710/1785-1690/1805-60/ 12SS	38	Feb. 28, 2021
5	Band Reject Filter	Wairwright Instruments Gmbh	WRCG 824/849-810/863-60/9SS	7	Feb. 28, 2021
6	Band Reject Filter	Wairwright Instruments Gmbh	WRCG 880/915-860/935-60/9SS	14	Feb. 28, 2021
7	Band Reject Filter	Wairwright Instruments Gmbh	WRCG 1850/1910-1830/1930-60/ 10SS	17	Feb. 28, 2021
8	HighPass Filter	Wairwright Instruments Gmbh	WHK3.1/18G-10SS	24	Feb. 28, 2021
9	Wireless Communication Test SET	Agilent	E5515C	MY48364183	Mar. 01, 2021
10	Microwave Preamplifier With Adaptor	EMC INSTRUMENT	EMC2654045	980039 & HA01	Mar. 07, 2021
11	Receiver	Agilent	N9038A	MY52130039	Jul. 25, 2021
12	wideband radio communication tester	R&S	CMW500	152372	Feb. 28, 2021
13	High pass filter	KANGMAIWEI	ZHPF-M3-12.75G-3869	B2015073763	Feb. 11, 2021
14	High pass filter	KANGMAIWEI	ZHPF-M1000-4000-1	B2015073762	Feb. 11, 2021
15	High pass filter	KANGMAIWEI	ZHPF-M6-186-1727	B2015073764	Feb. 11, 2021
16	Cable	emci	LMR-400(30MHz-1GHz)( 8m+5m)	N/A	May 22, 2021
17	Cable	mitron	B10-01-01-12M	18072744	Jun. 28, 2021
18	Controller	ETS-Lindgren	2090	N/A	N/A
19	Measurement Software	Farad	EZ-EMC Ver.NB-03A1-01	N/A	N/A
20	Loop Antenna	EM	EM-6876-1	230	Apr. 16, 2021
21	Double Ridged Guide Antenna	ETS	3115	75846	Mar. 19, 2021
22	Broad-Band Horn Antenna	Schwarzbeck	BBHA 9170	9170319	Jul. 07, 2021

Conducted Measurement					
Item	Kind of Equipment	Manufacturer	Type No.	Serial No.	Calibrated until
1	Wireless Communication Test SET	Agilent	E5515C	MY48364183	Mar. 01, 2021
2	EXA Spectrum Analyzer	Agilent	N9010A	MY50520044	Mar. 01, 2021
3	POWER SPLITTER	Mini-Circuits	ZFRSC-123-S+	331000910-1	Feb. 28, 2021
4	wideband radio communication tester	R&S	CMW500	152372	Feb. 28, 2021

Frequency Stability Measurement					
Item	Kind of Equipment	Manufacturer	Type No.	Serial No.	Calibrated until
1	Wireless Communication Test SET	Agilent	E5515C	MY48364183	Mar. 01, 2021
2	Multi-output DC Power Supply	GW Instek	GPC-3030DN	EK880675	Sep. 26, 2020
3	POWER SPLITTER	Mini-Circuits	ZFRSC-123-S+	331000910-1	Feb. 28, 2021
4	wideband radio communication tester	R&S	CMW500	152372	Feb. 28, 2021
5	Const Temp,& Humidity Chamber	Bell	BTH-50C	20170306001	Feb. 28, 2021

Remark: "N/A" denotes no model name, serial no. or calibration specified.  
 All calibration period of equipment list is one year.

## APPENDIX A - OUTPUT POWER



**Output Power (dBm):**

LTE Band / BW	Modulation	RB Size	RB Offset	Low CH	Mid CH	High CH
				26697CH	26740CH	26783CH
				814.7MHz	819MHz	823.3MHz
26 / 1.4M	QPSK	1	0	23.01	22.99	23.04
		1	2	23.11	23.07	23.16
		1	5	22.97	22.97	23.01
		3	0	23.13	23.11	23.10
		3	1	23.12	23.16	23.15
		3	2	23.07	23.15	23.09
		6	0	22.03	22.09	22.09
	16QAM	1	0	21.98	22.13	22.41
		1	2	22.05	22.26	22.48
		1	5	22.01	22.15	22.40
		3	0	22.18	22.16	22.28
		3	1	22.24	22.21	22.31
		3	2	22.21	22.16	22.29
		6	0	21.26	21.31	21.06
	64QAM	1	0	21.42	21.21	21.24
		1	2	21.59	21.37	21.31
		1	5	21.45	21.22	21.24
		3	0	21.38	21.27	21.08
		3	1	21.44	21.32	21.11
		3	2	21.38	21.29	21.10
		6	0	19.99	20.36	20.15

LTE Band / BW	Modulation	RB Size	RB Offset	Low CH	Mid CH	High CH
				26705CH	26740CH	26775CH
				815.5MHz	819MHz	822.5MHz
26 / 3M	QPSK	1	0	23.01	23.05	23.09
		1	7	23.14	23.16	23.22
		1	14	22.99	23.05	23.09
		8	0	22.01	22.08	22.08
		8	4	22.05	22.08	22.11
		8	7	22.04	22.04	22.06
		15	0	21.98	22.08	22.05
	16QAM	1	0	22.36	22.16	22.05
		1	7	22.57	22.24	22.12
		1	14	22.43	22.06	22.01
		8	0	21.17	21.15	21.27
		8	4	21.20	21.19	21.28
		8	7	21.17	21.16	21.23
		15	0	21.09	21.09	21.16
	64QAM	1	0	21.14	21.32	21.44
		1	7	21.35	21.44	21.57
		1	14	21.24	21.22	21.42
		8	0	20.05	20.04	20.16
		8	4	20.08	20.05	20.18
		8	7	20.11	20.03	20.11
		15	0	20.04	20.10	20.07

LTE Band / BW	Modulation	RB Size	RB Offset	Low CH	Mid CH	High CH
				26715CH	26740CH	26765CH
				816.5MHz	819MHz	821.5MHz
26 / 5M	QPSK	1	0	23.00	23.03	22.94
		1	13	23.10	23.17	23.07
		1	24	22.99	23.04	22.96
		12	0	21.99	22.00	22.04
		12	6	22.06	22.07	22.10
		12	11	22.09	22.10	22.10
		25	0	22.03	22.07	22.06
	16QAM	1	0	22.39	22.04	22.20
		1	13	22.57	22.16	22.27
		1	24	22.46	22.06	22.20
		12	0	21.13	21.09	21.14
		12	6	21.26	21.22	21.21
		12	11	21.27	21.21	21.21
		25	0	21.16	21.09	21.15
	64QAM	1	0	21.31	21.27	21.00
		1	13	21.48	21.38	21.11
		1	24	21.36	21.24	20.97
		12	0	19.93	20.05	20.06
		12	6	20.00	20.18	20.15
		12	11	20.03	20.19	20.14
		25	0	20.00	20.10	20.05

LTE Band / BW	Modulation	RB Size	RB Offset	Mid CH
				26740CH
				819MHz
26 / 10M	QPSK	1	0	23.07
		1	25	23.24
		1	49	23.03
		25	0	22.02
		25	13	22.12
		25	25	22.08
		50	0	22.12
	16QAM	1	0	22.32
		1	25	22.56
		1	49	22.36
		25	0	21.13
		25	13	21.21
		25	25	21.20
		50	0	21.21
	64QAM	1	0	21.20
		1	25	21.42
		1	49	21.21
		25	0	20.12
		25	13	20.20
		25	25	20.21
		50	0	20.13

**ERP (dBm):**

LTE Band / BW	Modulation	RB Size	RB Offset	Low CH	Mid CH	High CH
				26697CH	26740CH	26783CH
				814.7MHz	819MHz	823.3MHz
26 / 1.4M	QPSK	1	0	21.36	21.34	21.39
		1	2	21.46	21.42	21.51
		1	5	21.32	21.32	21.36
		3	0	21.48	21.46	21.45
		3	1	21.47	21.51	21.50
		3	2	21.42	21.50	21.44
		6	0	20.38	20.44	20.44
	16QAM	1	0	20.33	20.48	20.76
		1	2	20.40	20.61	20.83
		1	5	20.36	20.50	20.75
		3	0	20.53	20.51	20.63
		3	1	20.59	20.56	20.66
		3	2	20.56	20.51	20.64
		6	0	19.61	19.66	19.41
	64QAM	1	0	19.77	19.56	19.59
		1	2	19.94	19.72	19.66
		1	5	19.80	19.57	19.59
		3	0	19.73	19.62	19.43
		3	1	19.79	19.67	19.46
		3	2	19.73	19.64	19.45
		6	0	18.34	18.71	18.50

LTE Band / BW	Modulation	RB Size	RB Offset	Low CH	Mid CH	High CH
				26705CH	26740CH	26775CH
				815.5MHz	819MHz	822.5MHz
26 / 3M	QPSK	1	0	21.36	21.40	21.44
		1	7	21.49	21.51	21.57
		1	14	21.34	21.40	21.44
		8	0	20.36	20.43	20.43
		8	4	20.40	20.43	20.46
		8	7	20.39	20.39	20.41
		15	0	20.33	20.43	20.40
	16QAM	1	0	20.71	20.51	20.40
		1	7	20.92	20.59	20.47
		1	14	20.78	20.41	20.36
		8	0	19.52	19.50	19.62
		8	4	19.55	19.54	19.63
		8	7	19.52	19.51	19.58
		15	0	19.44	19.44	19.51
	64QAM	1	0	19.49	19.67	19.79
		1	7	19.70	19.79	19.92
		1	14	19.59	19.57	19.77
		8	0	18.40	18.39	18.51
		8	4	18.43	18.40	18.53
		8	7	18.46	18.38	18.46
		15	0	18.39	18.45	18.42

LTE Band / BW	Modulation	RB Size	RB Offset	Low CH	Mid CH	High CH
				26715CH	26740CH	26765CH
				816.5MHz	819MHz	821.5MHz
26 / 5M	QPSK	1	0	21.35	21.38	21.29
		1	13	21.45	21.52	21.42
		1	24	21.34	21.39	21.31
		12	0	20.34	20.35	20.39
		12	6	20.41	20.42	20.45
		12	11	20.44	20.45	20.45
		25	0	20.38	20.42	20.41
	16QAM	1	0	20.74	20.39	20.55
		1	13	20.92	20.51	20.62
		1	24	20.81	20.41	20.55
		12	0	19.48	19.44	19.49
		12	6	19.61	19.57	19.56
		12	11	19.62	19.56	19.56
		25	0	19.51	19.44	19.50
	64QAM	1	0	19.66	19.62	19.35
		1	13	19.83	19.73	19.46
		1	24	19.71	19.59	19.32
		12	0	18.28	18.40	18.41
		12	6	18.35	18.53	18.50
		12	11	18.38	18.54	18.49
		25	0	18.35	18.45	18.40

LTE Band / BW	Modulation	RB Size	RB Offset	Mid CH
				26740CH
				819MHz
26 / 10M	QPSK	1	0	21.42
		1	25	21.59
		1	49	21.38
		25	0	20.37
		25	13	20.47
		25	25	20.43
		50	0	20.47
	16QAM	1	0	20.67
		1	25	20.91
		1	49	20.71
		25	0	19.48
		25	13	19.56
		25	25	19.55
		50	0	19.56
	64QAM	1	0	19.55
		1	25	19.77
		1	49	19.56
		25	0	18.47
		25	13	18.55
		25	25	18.56
		50	0	18.48

## APPENDIX B - OCCUPIED BANDWIDTH

LTE Band 26_1.4M					
QPSK					
Channel	Frequency (MHz)	99% Occupied Bandwidth (MHz)	Channel	Frequency (MHz)	26dB Bandwidth (MHz)
26697	814.7	1.0999	26697	814.7	1.295
26740	819	1.0839	26740	819	1.278
26783	823.3	1.0915	26783	823.3	1.284
16QAM					
Channel	Frequency (MHz)	99% Occupied Bandwidth (MHz)	Channel	Frequency (MHz)	26dB Bandwidth (MHz)
26697	814.7	1.0926	26697	814.7	1.268
26740	819	1.0892	26740	819	1.287
26783	823.3	1.0909	26783	823.3	1.286
64QAM					
Channel	Frequency (MHz)	99% Occupied Bandwidth (MHz)	Channel	Frequency (MHz)	26dB Bandwidth (MHz)
26697	814.7	1.0905	26697	814.7	1.263
26740	819	1.0869	26740	819	1.278
26783	823.3	1.0900	26783	823.3	1.304

## Spectrum Plot

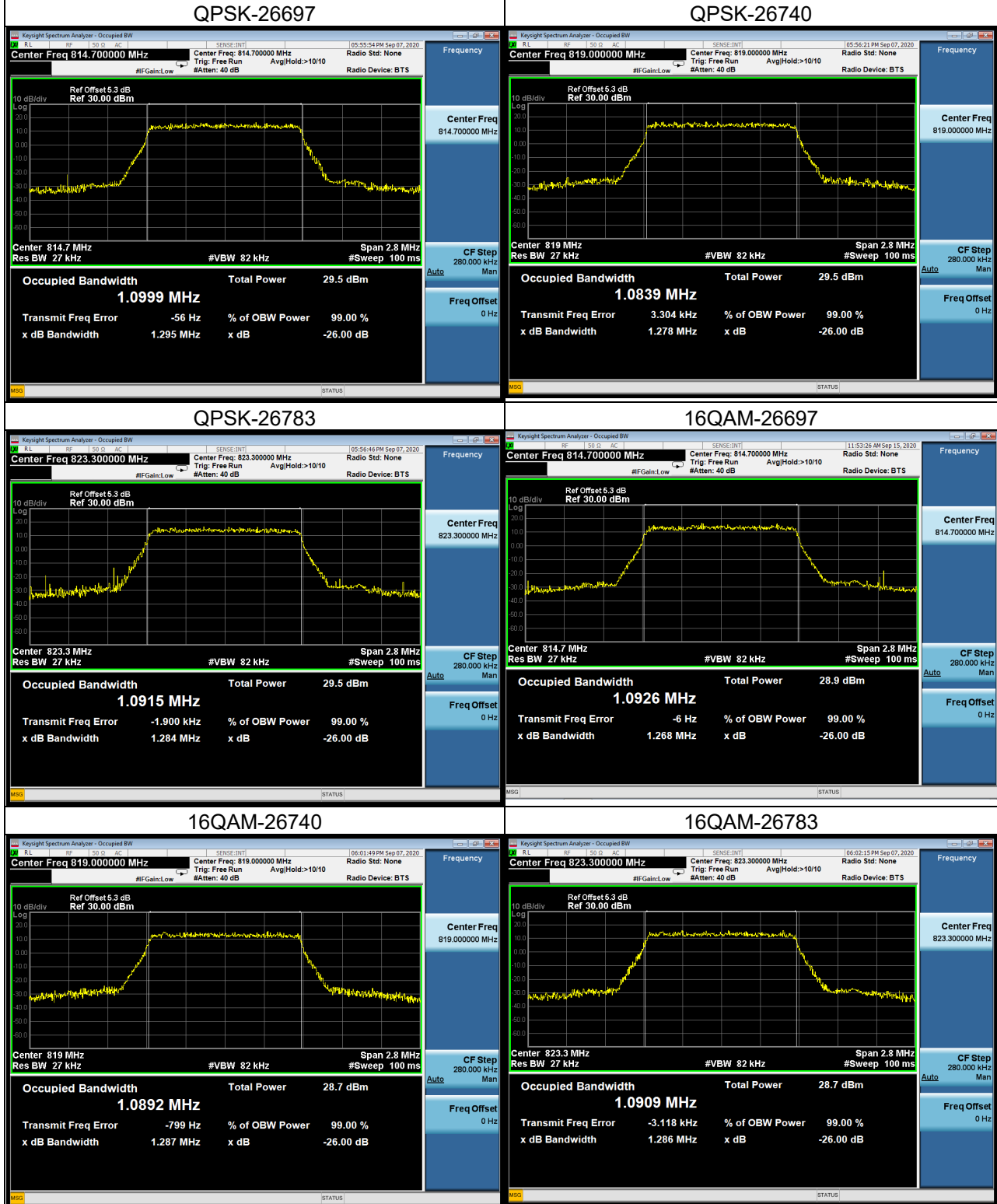

## Spectrum Plot

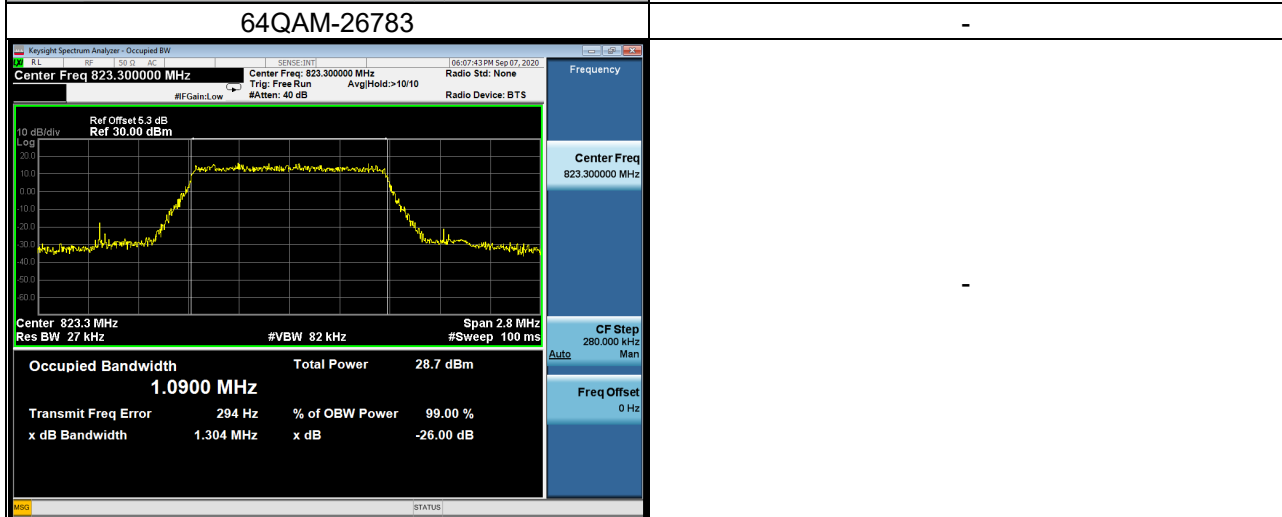



LTE Band 26_3M					
QPSK					
Channel	Frequency (MHz)	99% Occupied Bandwidth (MHz)	Channel	Frequency (MHz)	26dB Bandwidth (MHz)
26705	815.5	2.6932	26705	815.5	2.910
26740	819	2.6856	26740	819	2.896
26775	822.5	2.6819	26775	822.5	2.926
16QAM					
Channel	Frequency (MHz)	99% Occupied Bandwidth (MHz)	Channel	Frequency (MHz)	26dB Bandwidth (MHz)
26705	815.5	2.6833	26705	815.5	2.920
26740	819	2.6783	26740	819	2.928
26775	822.5	2.6883	26775	822.5	2.921
64QAM					
Channel	Frequency (MHz)	99% Occupied Bandwidth (MHz)	Channel	Frequency (MHz)	26dB Bandwidth (MHz)
26705	815.5	2.6830	26705	815.5	2.914
26740	819	2.6812	26740	819	2.915
26775	822.5	2.6870	26775	822.5	2.906

## Spectrum Plot

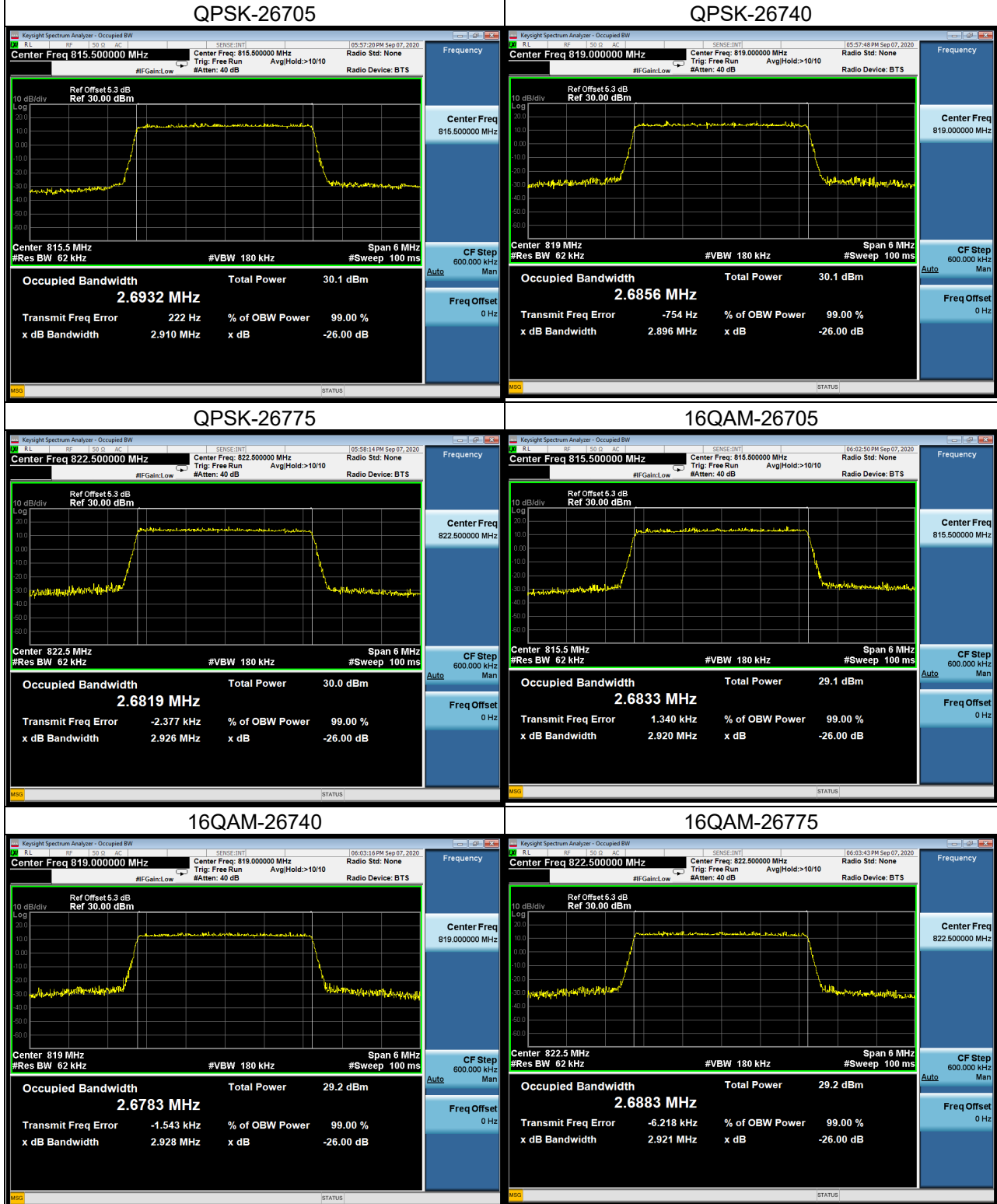

## Spectrum Plot

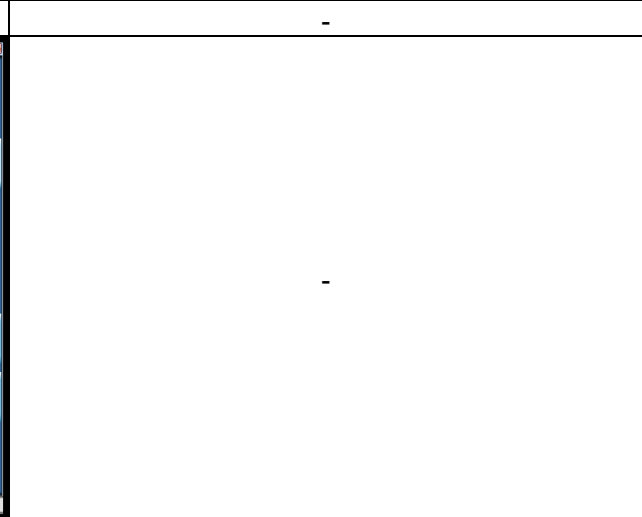
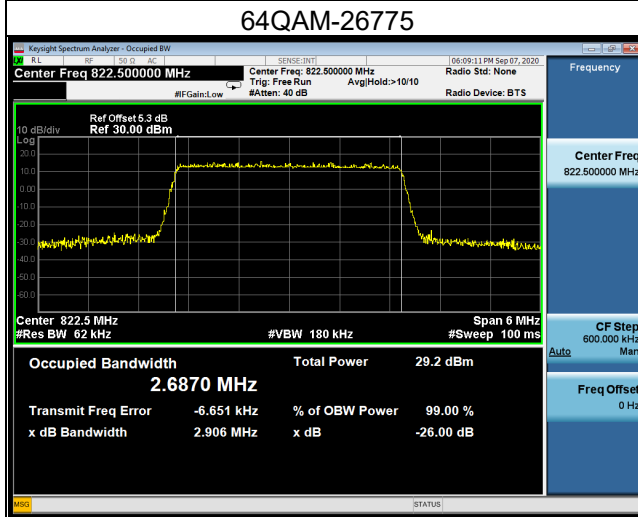
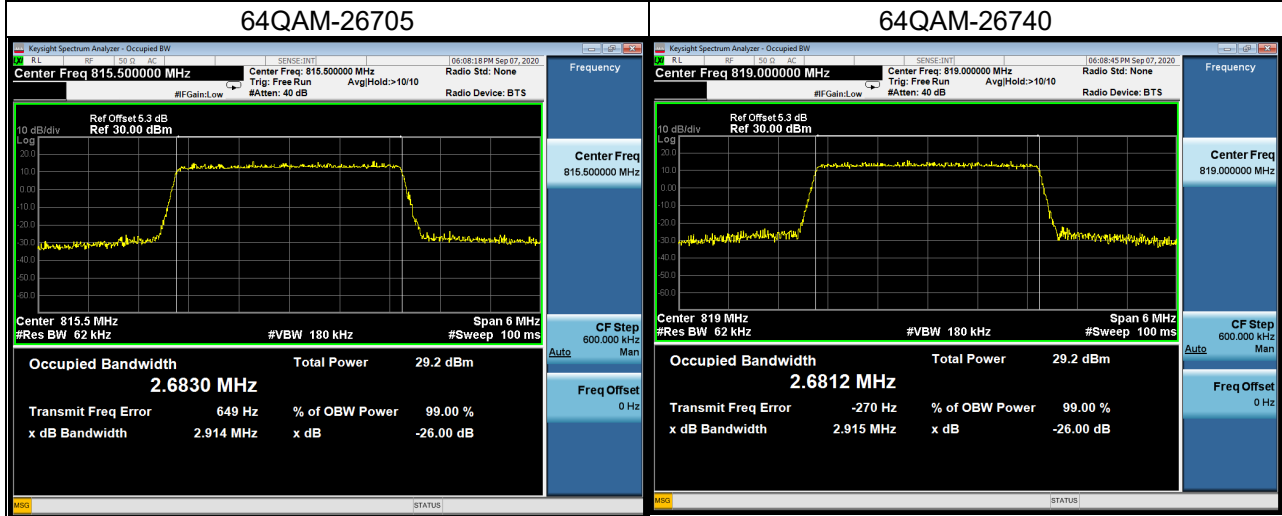

LTE Band 26_5M					
QPSK					
Channel	Frequency (MHz)	99% Occupied Bandwidth (MHz)	Channel	Frequency (MHz)	26dB Bandwidth (MHz)
26715	816.5	4.4924	26715	816.5	4.895
26740	819	4.4908	26740	819	4.876
26765	821.5	4.5034	26765	821.5	4.921
16QAM					
Channel	Frequency (MHz)	99% Occupied Bandwidth (MHz)	Channel	Frequency (MHz)	26dB Bandwidth (MHz)
26715	816.5	4.4829	26715	816.5	4.899
26740	819	4.4829	26740	819	4.868
26765	821.5	4.4958	26765	821.5	4.921
64QAM					
Channel	Frequency (MHz)	99% Occupied Bandwidth (MHz)	Channel	Frequency (MHz)	26dB Bandwidth (MHz)
26715	816.5	4.4878	26715	816.5	4.907
26740	819	4.4857	26740	819	4.849
26765	821.5	4.4909	26765	821.5	4.904

## Spectrum Plot

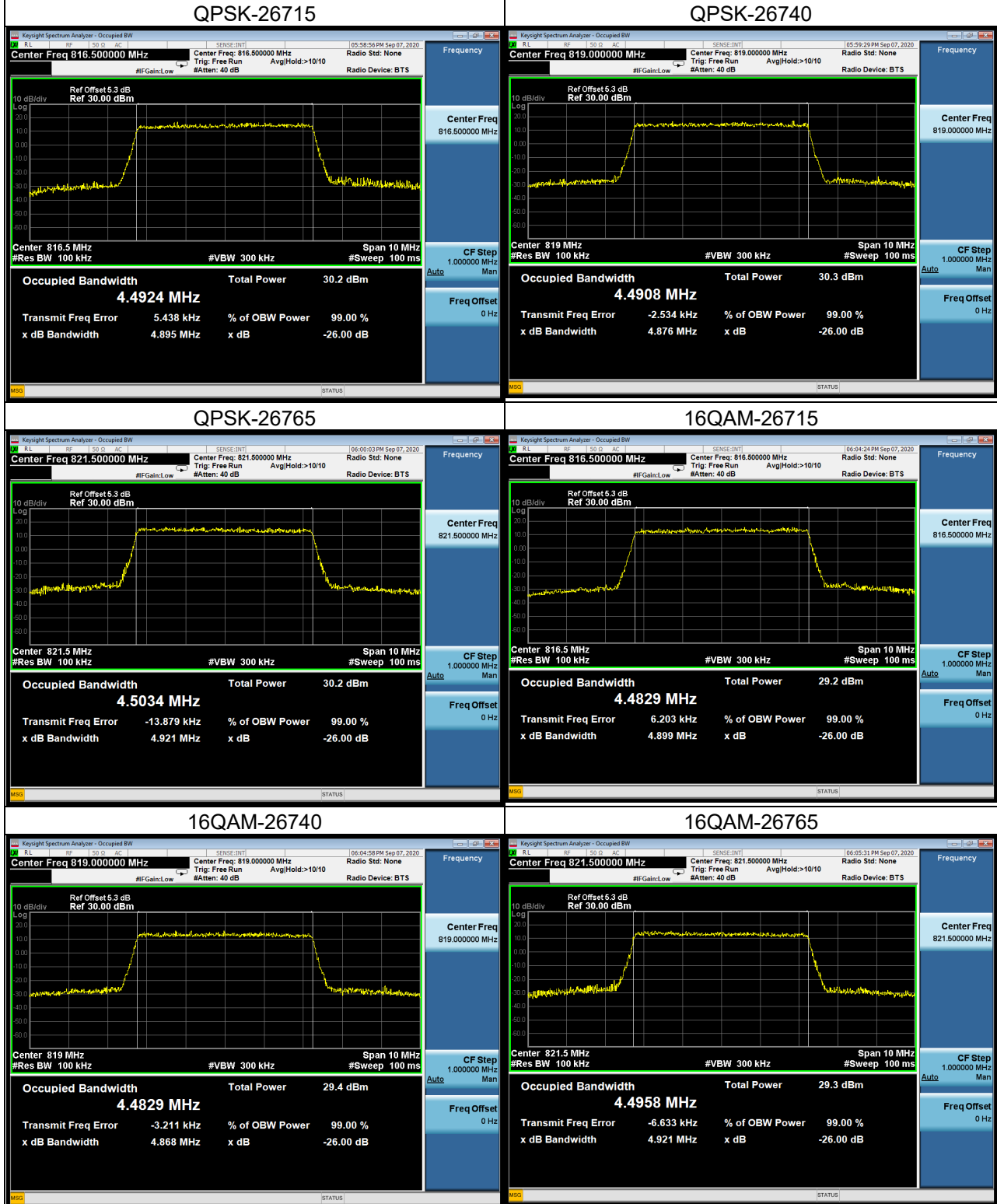

## Spectrum Plot

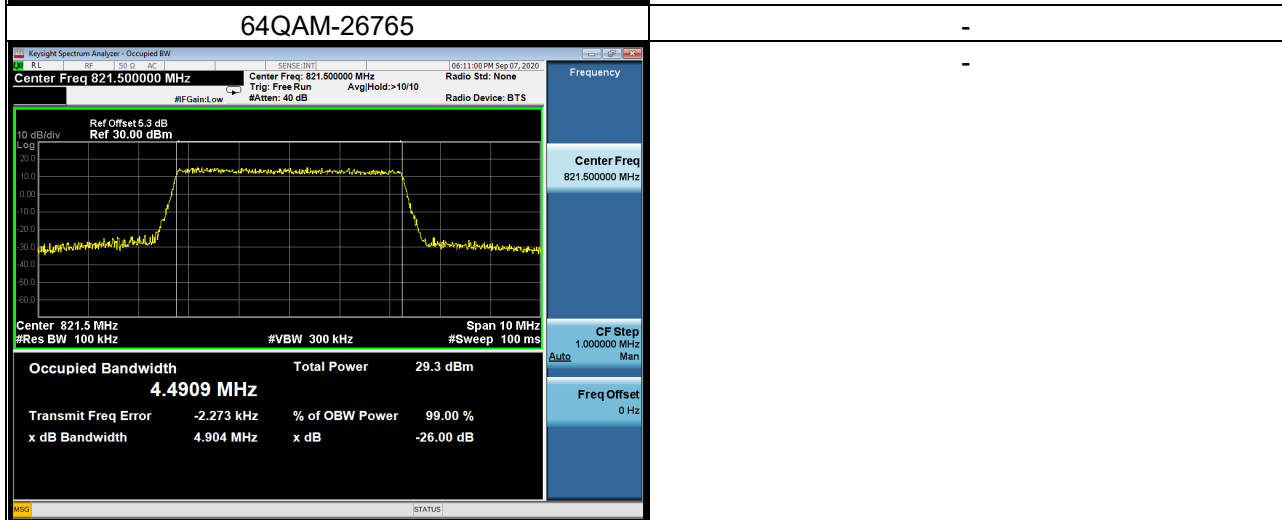

LTE Band 26_10M					
QPSK					
Channel	Frequency (MHz)	99% Occupied Bandwidth (MHz)	Channel	Frequency (MHz)	26dB Bandwidth (MHz)
26740	819	8.9515	26740	819	9.718
16QAM					
Channel	Frequency (MHz)	99% Occupied Bandwidth (MHz)	Channel	Frequency (MHz)	26dB Bandwidth (MHz)
26740	819	8.9439	26740	819	9.639
64QAM					
Channel	Frequency (MHz)	99% Occupied Bandwidth (MHz)	Channel	Frequency (MHz)	26dB Bandwidth (MHz)
26740	819	8.9406	26740	819	9.672

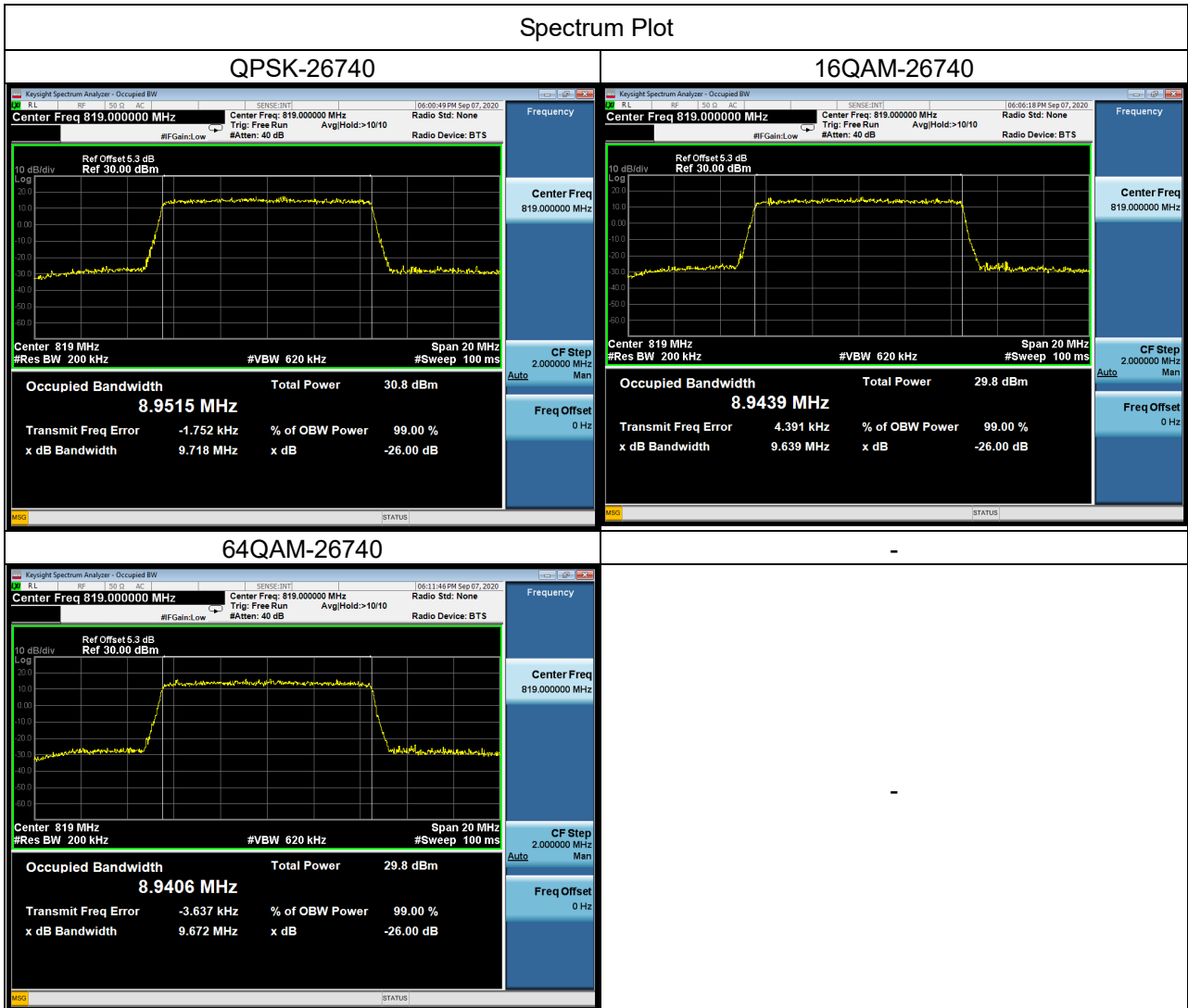

## **APPENDIX C - CONDUCTED SPURIOUS EMISSIONS**



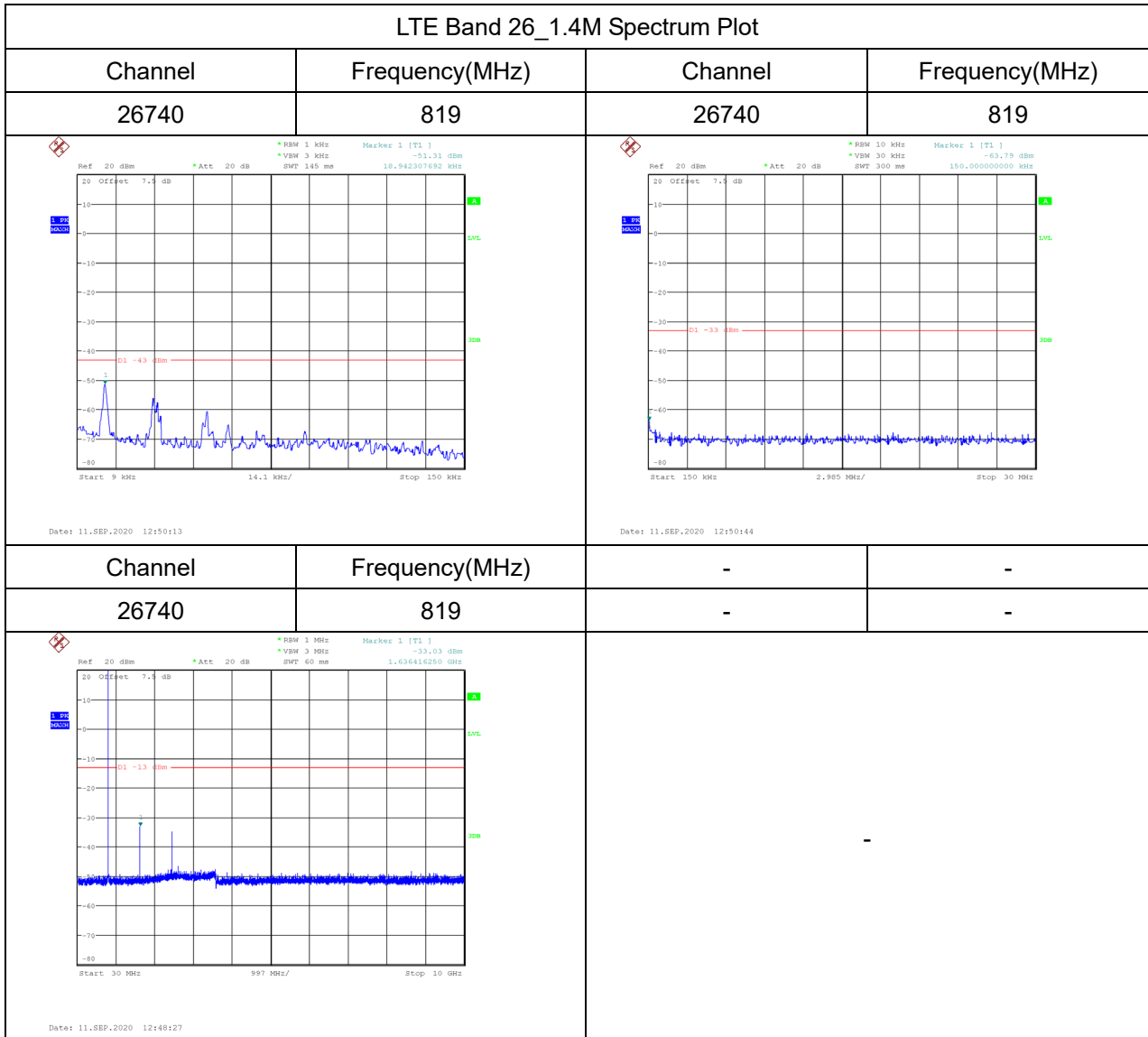

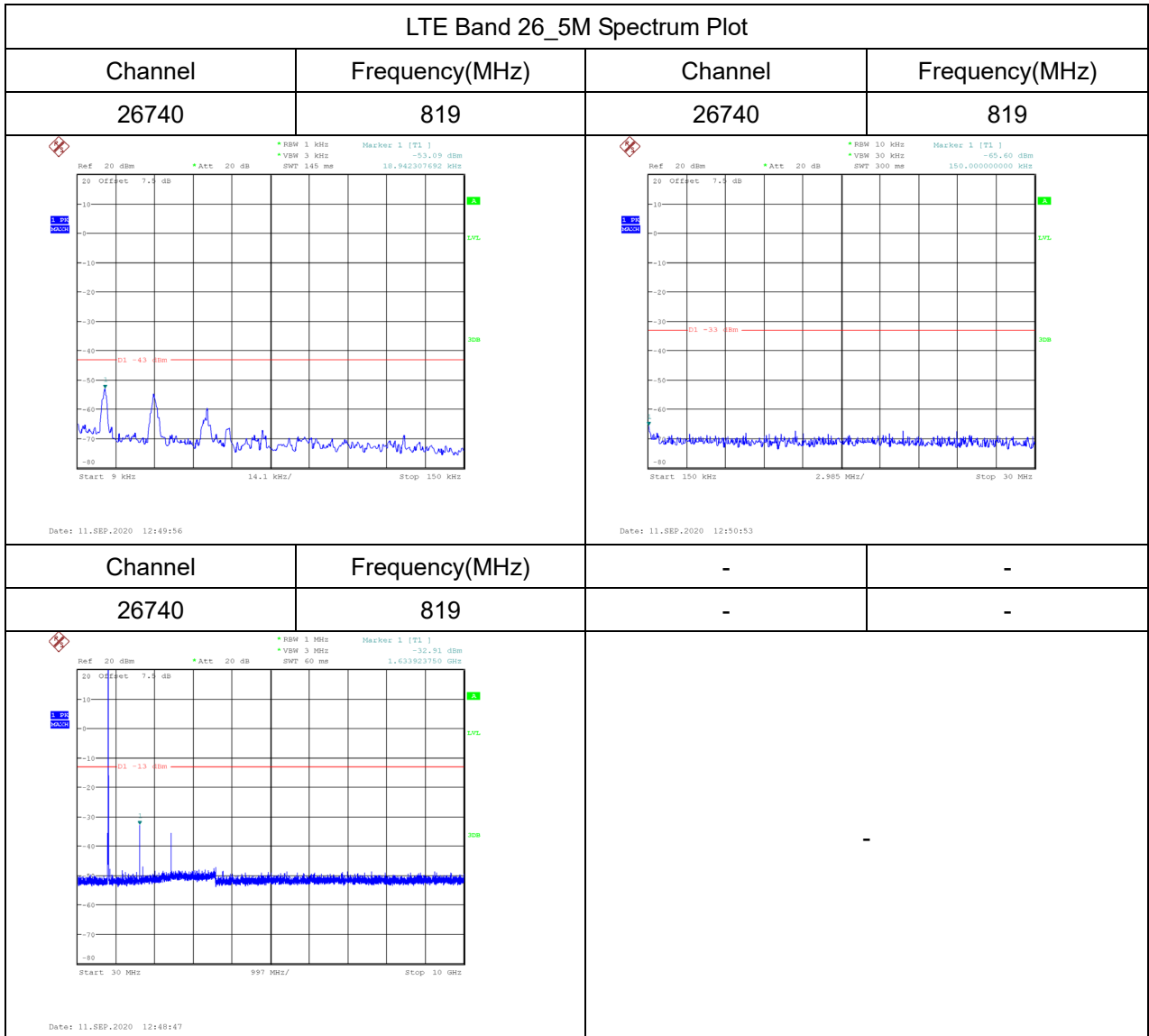

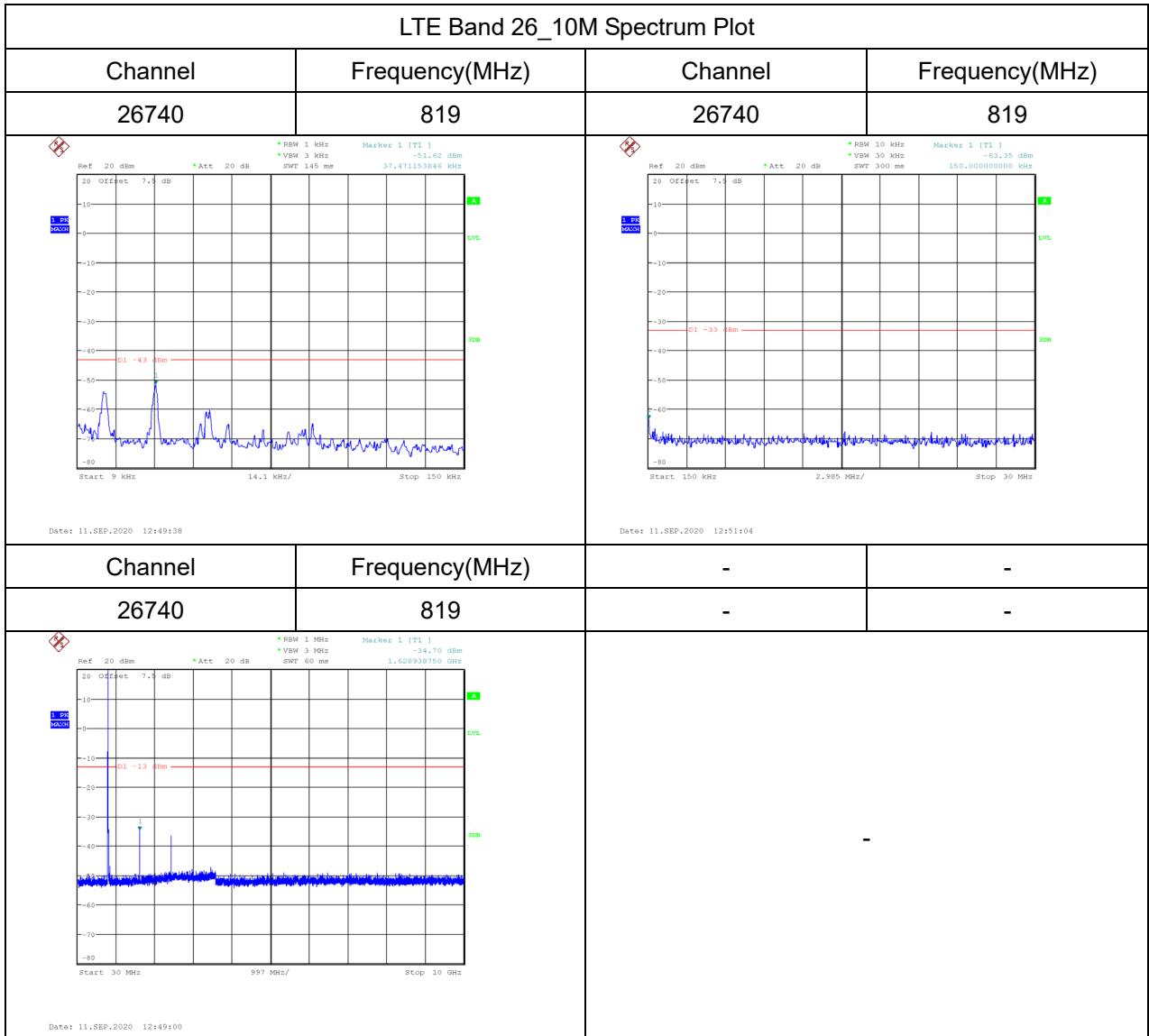

## **APPENDIX D - RADIATED SPURIOUS EMISSIONS (9KHZ TO 30MHZ)**

Test Mode TX Mode

Ant 0°

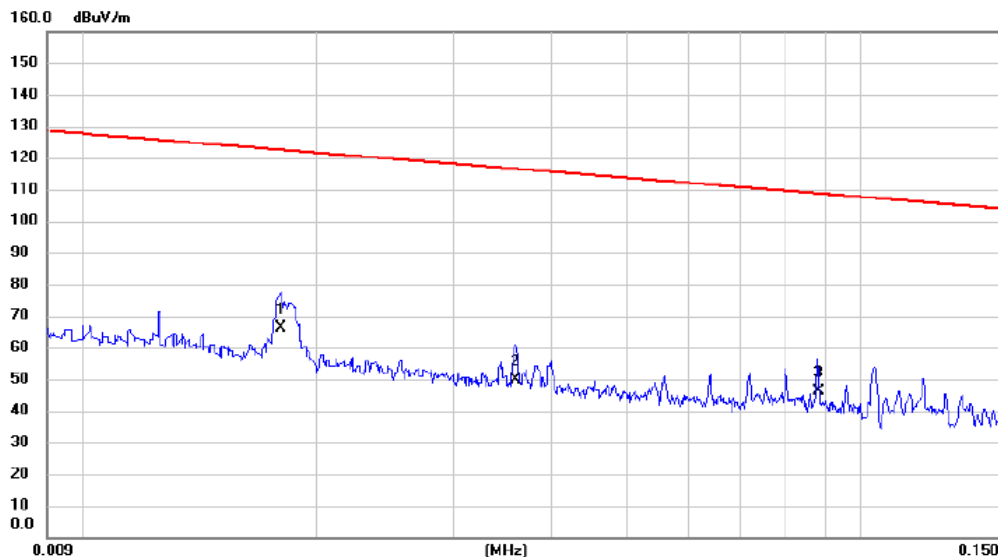

No.	Mk.	Freq. MHz	Reading Level dBuV	Correct Factor dB	Measure- ment dBuV/m	Limit dBuV/m	Margin dB	Detector	Comment
1	*	0.0180	52.46	13.84	66.30	122.50	-56.20	AVG	
2		0.0360	37.15	12.79	49.94	116.48	-66.54	AVG	
3		0.0881	33.65	12.65	46.30	108.71	-62.41	AVG	

Test Mode	TX Mode
-----------	---------

**Ant 0°**

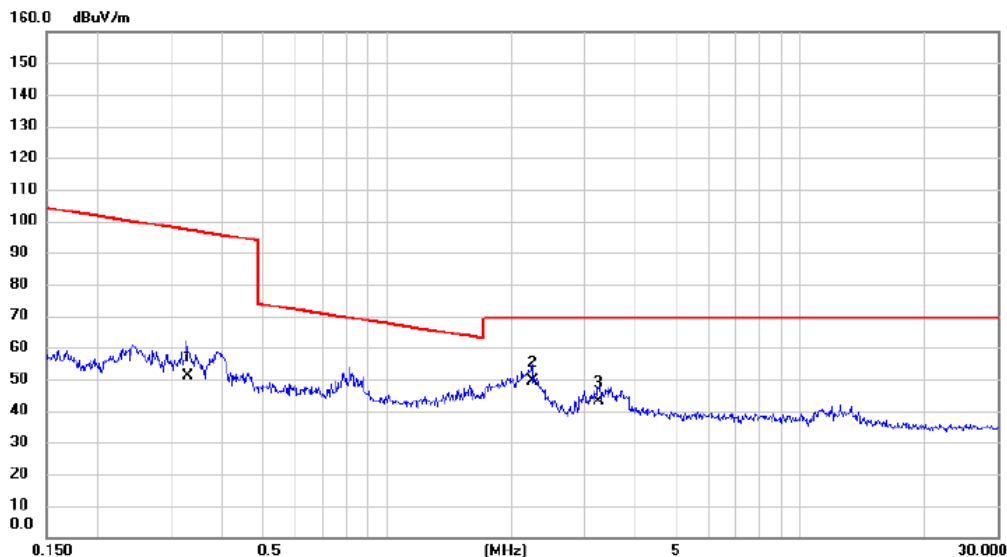

No.	Mk.	Freq. MHz	Reading	Correct	Measure-	Limit	Margin	Detector	Comment
			Level dBuV	Factor dB	ment dBuV/m	dBuV/m	dB		
1		0.3286	38.58	12.44	51.02	97.27	-46.25	AVG	
2	*	2.2486	38.15	11.18	49.33	69.54	-20.21	QP	
3		3.2411	32.35	10.84	43.19	69.54	-26.35	QP	

Test Mode	TX Mode
-----------	---------

**Ant 90°**

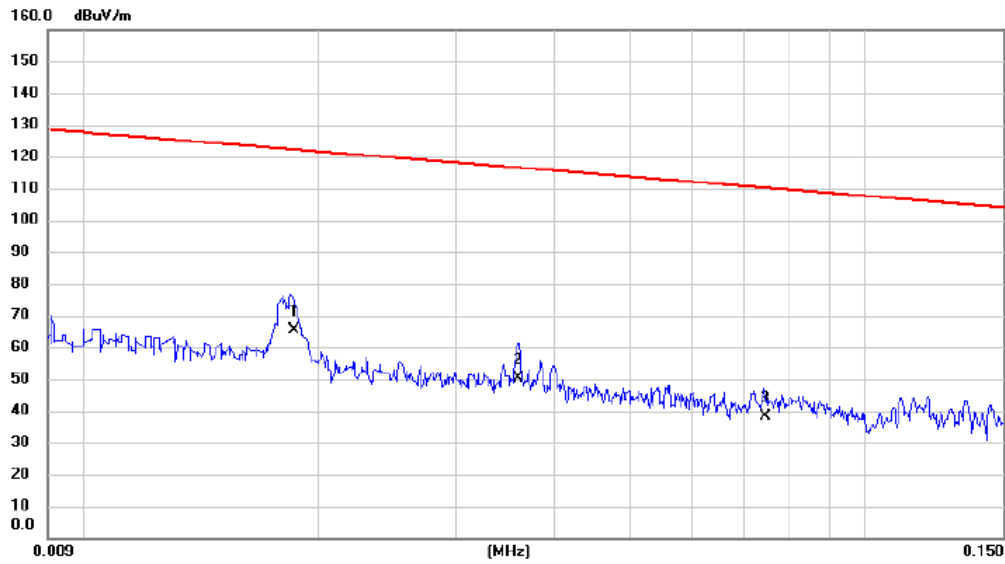

No.	Mk.	Freq.	Reading Level	Correct Factor	Measurement	Limit	Margin	Detector	Comment
		MHz	dBuV	dB	dBuV/m	dBuV/m	dB		
1	*	0.0186	51.68	13.65	65.33	122.21	-56.88	AVG	
2		0.0360	37.58	12.79	50.37	116.48	-66.11	AVG	
3		0.0744	25.77	12.57	38.34	110.17	-71.83	AVG	

Test Mode TX Mode

Ant 90°

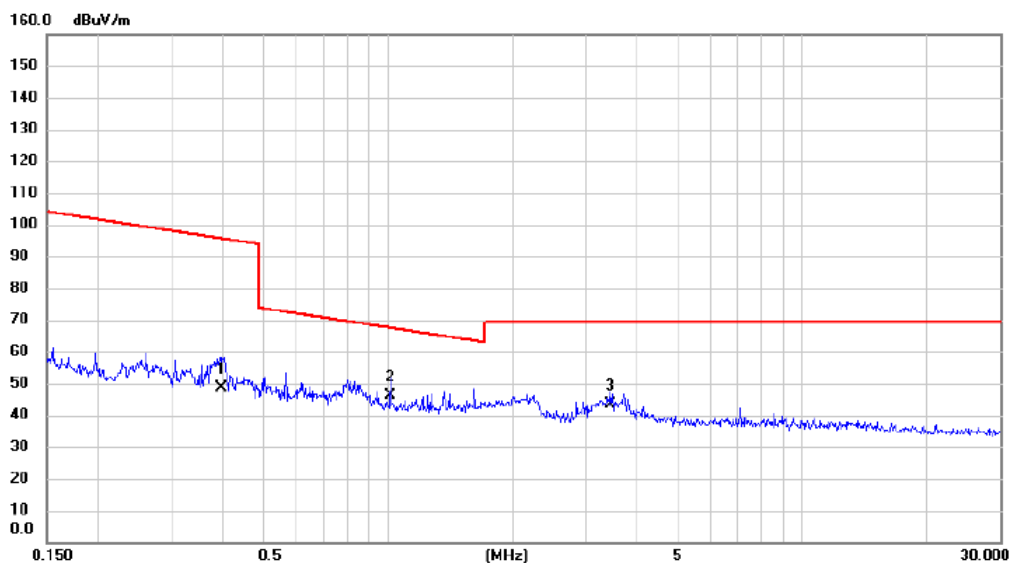

No.	Mk.	Freq. MHz	Reading Level dBuV	Correct Factor dB	Measure- ment dBuV/m	Limit dBuV/m	Margin dB	Detector	Comment
1		0.3955	36.53	12.27	48.80	95.66	-46.86	AVG	
2	*	1.0157	34.25	11.79	46.04	67.47	-21.43	QP	
3		3.4538	32.53	10.87	43.40	69.54	-26.14	QP	



## **APPENDIX E - RADIATED SPURIOUS EMISSIONS (30MHZ TO 1000MHZ)**

Test Mode LTE Band 26\_TX CH26740\_1.4M\_Main Antenna

### Vertical

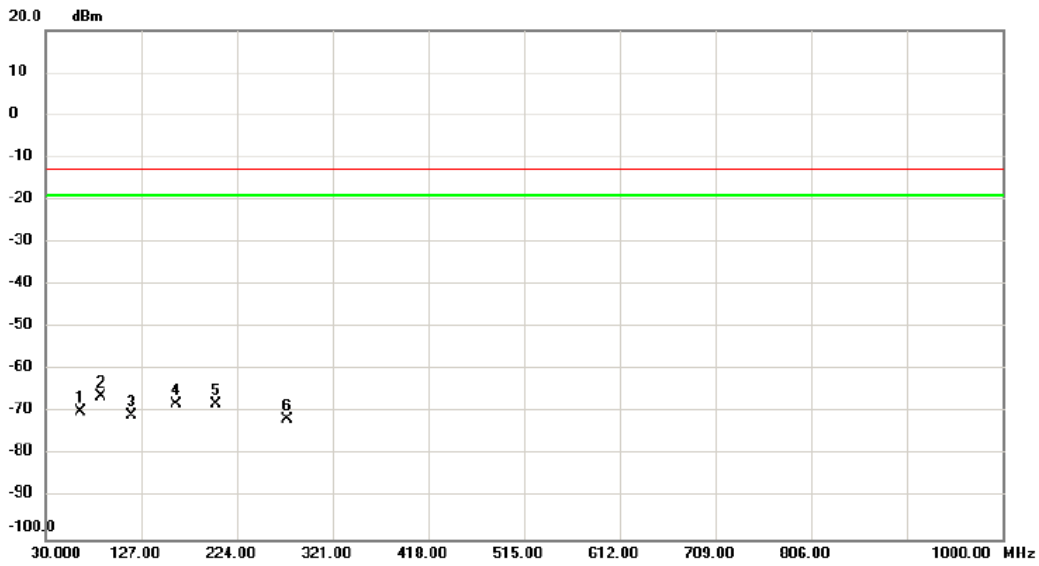

No.	Mk.	Freq. MHz	Reading Level dBm	Correct Factor dB	Measure- ment dBm	Limit dBm	Margin dB	Detector	Comment
1		65.890	-54.74	-15.05	-69.79	-13.00	-56.79	peak	
2	*	86.745	-49.83	-16.39	-66.22	-13.00	-53.22	peak	
3		117.300	-57.64	-13.14	-70.78	-13.00	-57.78	peak	
4		161.920	-57.24	-10.94	-68.18	-13.00	-55.18	peak	
5		203.145	-53.10	-14.94	-68.04	-13.00	-55.04	peak	
6		274.925	-59.10	-12.41	-71.51	-13.00	-58.51	peak	

Test Mode | LTE Band 26\_TX CH26740\_1.4M\_Main Antenna

### Horizontal

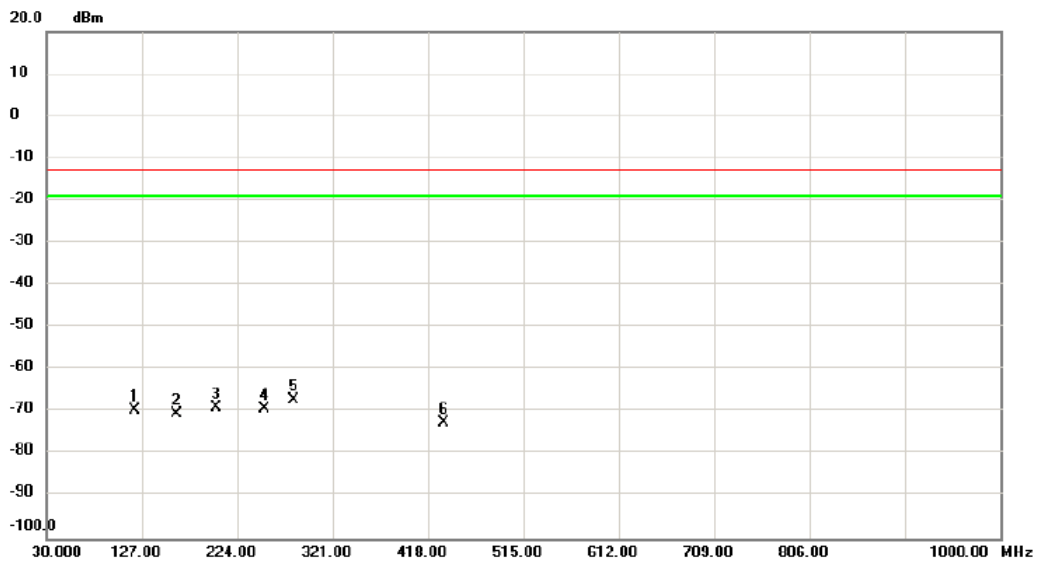

No.	Mk.	Freq.	Reading Level	Correct Factor	Measurement	Limit	Margin	Detector	Comment
		MHz	dBm	dB	dBm	dBm	dB		
1		120.210	-56.91	-12.74	-69.65	-13.00	-56.65	peak	
2		162.405	-59.45	-11.01	-70.46	-13.00	-57.46	peak	
3		203.145	-54.00	-14.94	-68.94	-13.00	-55.94	peak	
4		252.130	-56.30	-13.08	-69.38	-13.00	-56.38	peak	
5	*	281.715	-55.13	-12.05	-67.18	-13.00	-54.18	peak	
6		434.005	-64.33	-8.07	-72.40	-13.00	-59.40	peak	

Test Mode LTE Band 26\_TX CH26740\_5M\_Main Antenna

### Vertical

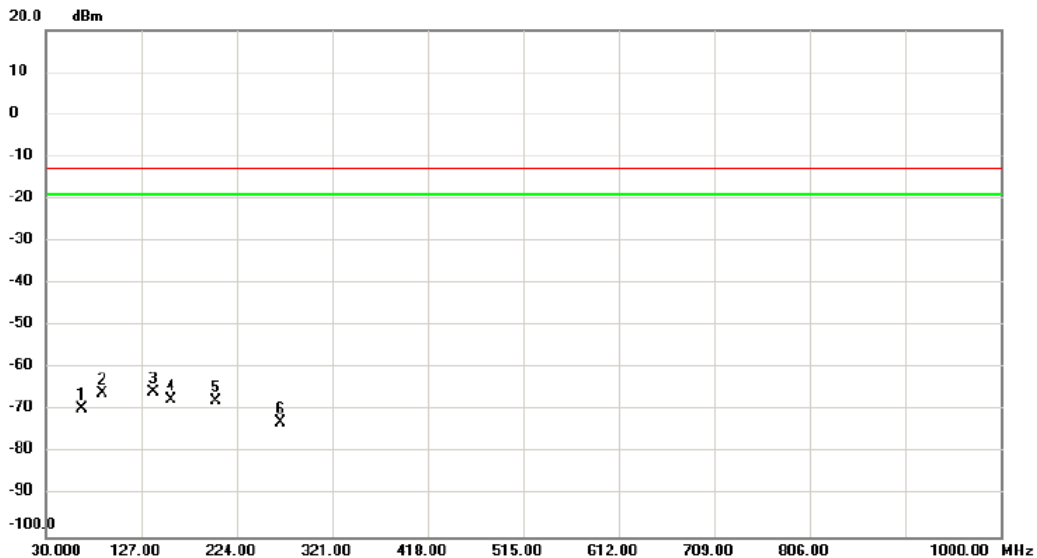

No.	Mk.	Freq. MHz	Reading Level dBm	Correct Factor dB	Measure- ment dBm	Limit dBm	Margin dB	Detector	Comment
1		66.375	-54.51	-15.15	-69.66	-13.00	-56.66	peak	
2		87.715	-49.88	-16.20	-66.08	-13.00	-53.08	peak	
3	*	139.125	-53.21	-12.57	-65.78	-13.00	-52.78	peak	
4		157.555	-56.60	-10.98	-67.58	-13.00	-54.58	peak	
5		202.660	-52.80	-14.92	-67.72	-13.00	-54.72	peak	
6		268.620	-60.16	-12.59	-72.75	-13.00	-59.75	peak	

Test Mode | LTE Band 26\_TX CH26740\_5M\_Main Antenna

### Horizontal

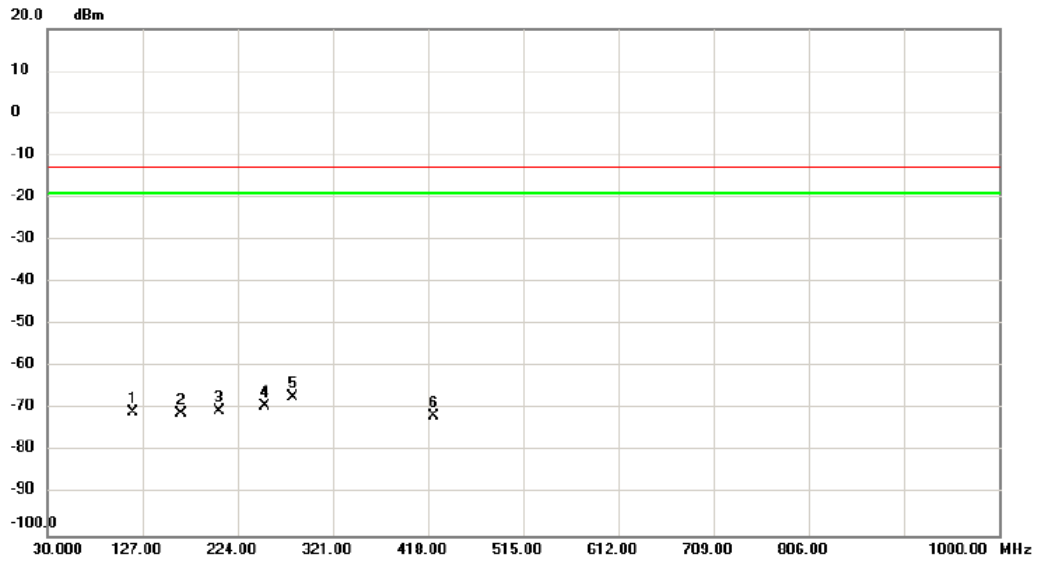

No.	Mk.	Freq. MHz	Reading Level dBm	Correct Factor dB	Measure- ment dBm	Limit dBm	Margin dB	Detector	Comment
1		117.300	-57.72	-13.14	-70.86	-13.00	-57.86	peak	
2		166.770	-59.29	-11.63	-70.92	-13.00	-57.92	peak	
3		205.085	-55.43	-15.01	-70.44	-13.00	-57.44	peak	
4		251.645	-56.20	-13.13	-69.33	-13.00	-56.33	peak	
5	*	280.745	-55.07	-12.12	-67.19	-13.00	-54.19	peak	
6		423.335	-63.39	-8.37	-71.76	-13.00	-58.76	peak	

Test Mode LTE Band 26\_TX CH26740\_10M\_Main Antenna

### Vertical

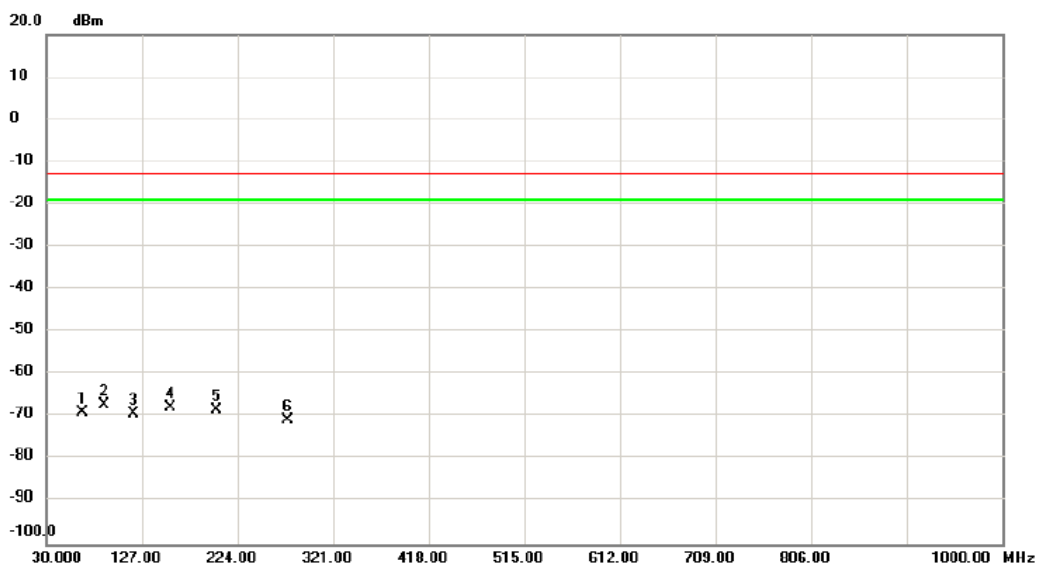

No.	Mk.	Freq. MHz	Reading Level dBm	Correct Factor dB	Measure- ment dBm	Limit dBm	Margin dB	Detector	Comment
1		66.375	-53.94	-15.15	-69.09	-13.00	-56.09	peak	
2	*	88.200	-50.98	-16.09	-67.07	-13.00	-54.07	peak	
3		118.270	-56.24	-12.99	-69.23	-13.00	-56.23	peak	
4		155.615	-56.53	-11.24	-67.77	-13.00	-54.77	peak	
5		202.660	-53.29	-14.92	-68.21	-13.00	-55.21	peak	
6		274.440	-58.38	-12.43	-70.81	-13.00	-57.81	peak	

Test Mode | LTE Band 26\_TX CH26740\_10M\_Main Antenna

### Horizontal

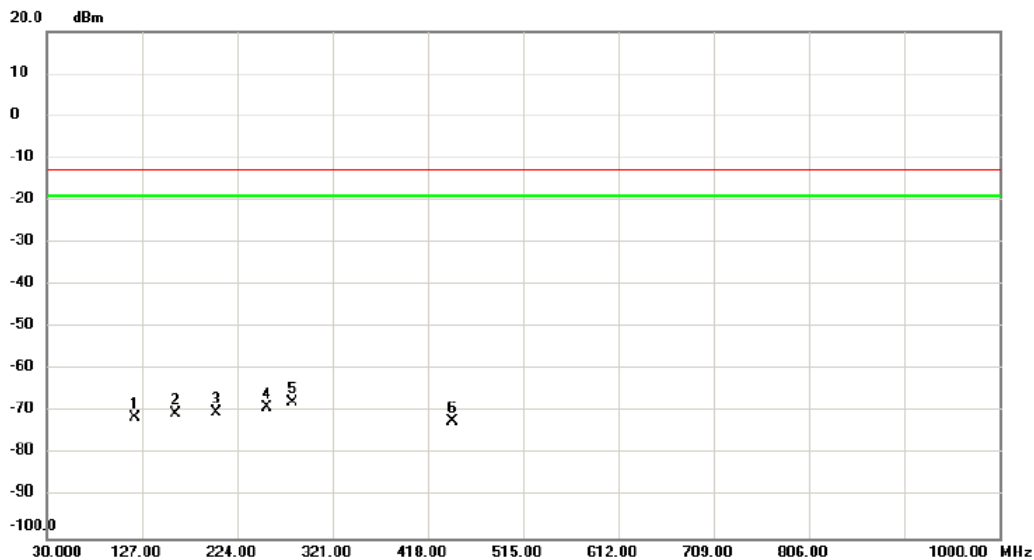

No.	Mk.	Freq. MHz	Reading Level dBm	Correct Factor dB	Measure- ment dBm	Limit dBm	Margin dB	Detector	Comment
1		120.210	-58.67	-12.74	-71.41	-13.00	-58.41	peak	
2		160.950	-59.65	-10.80	-70.45	-13.00	-57.45	peak	
3		203.145	-55.23	-14.94	-70.17	-13.00	-57.17	peak	
4		254.070	-56.01	-12.86	-68.87	-13.00	-55.87	peak	
5	*	279.775	-55.50	-12.17	-67.67	-13.00	-54.67	peak	
6		443.705	-64.37	-7.82	-72.19	-13.00	-59.19	peak	

Test Mode LTE Band 26\_TX CH26740\_1.4M\_Second Antenna

### Vertical

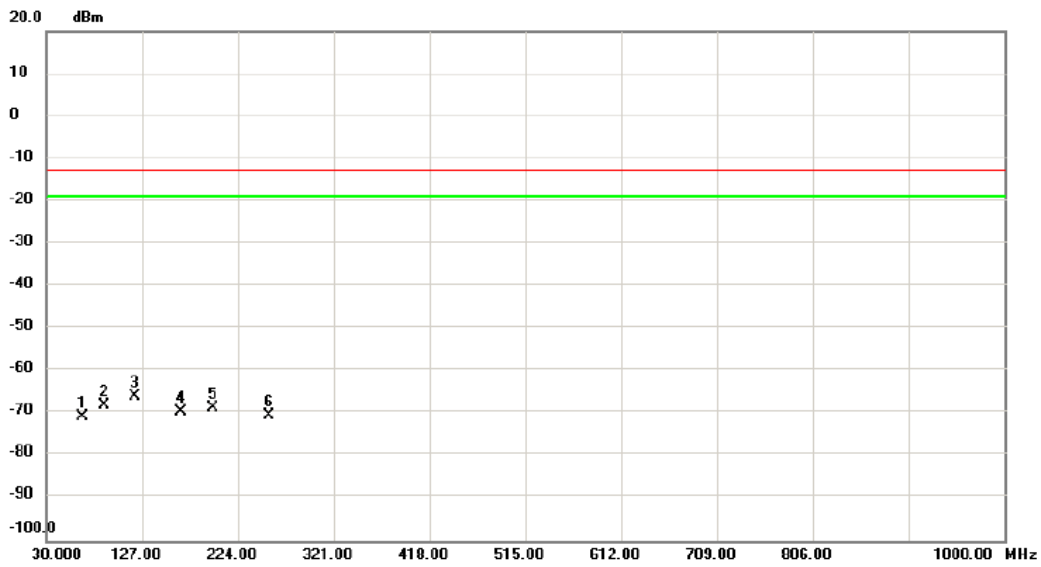

No.	Mk.	Freq. MHz	Reading Level dBm	Correct Factor dB	Measure- ment dBm	Limit dBm	Margin dB	Detector	Comment
1		66.375	-55.60	-15.15	-70.75	-13.00	-57.75	peak	
2		88.685	-52.06	-15.99	-68.05	-13.00	-55.05	peak	
3	*	120.210	-53.20	-12.74	-65.94	-13.00	-52.94	peak	
4		166.770	-57.85	-11.63	-69.48	-13.00	-56.48	peak	
5		198.780	-53.97	-14.72	-68.69	-13.00	-55.69	peak	
6		255.040	-57.55	-12.76	-70.31	-13.00	-57.31	peak	



Test Mode | LTE Band 26\_TX CH26740\_1.4M\_Second Antenna

### Horizontal

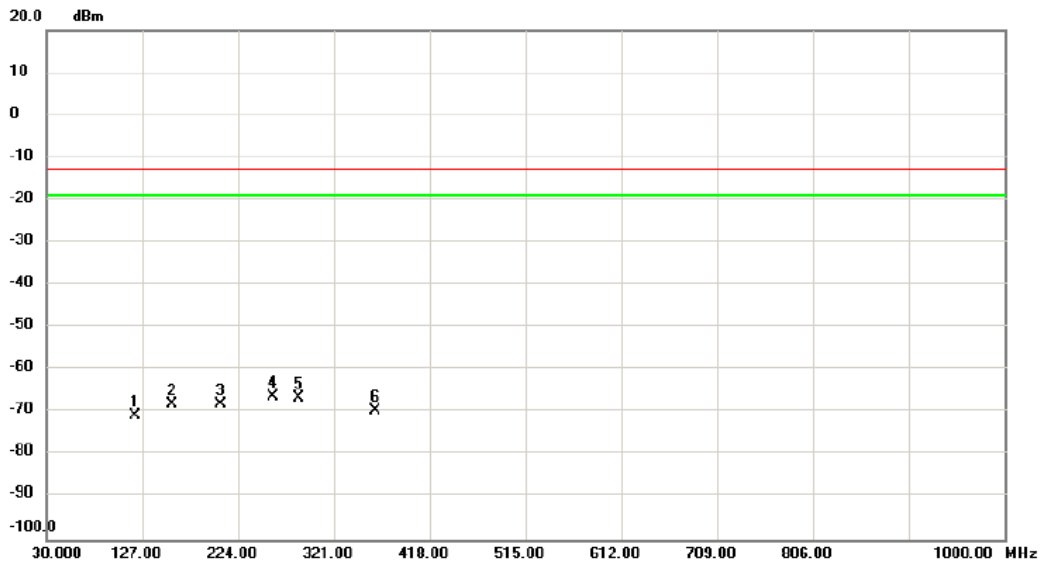

No.	Mk.	Freq. MHz	Reading Level dBm	Correct Factor dB	Measure- ment dBm	Limit dBm	Margin dB	Detector	Comment
1		119.725	-58.10	-12.78	-70.88	-13.00	-57.88	peak	
2		157.070	-57.12	-11.05	-68.17	-13.00	-55.17	peak	
3		206.055	-52.85	-15.06	-67.91	-13.00	-54.91	peak	
4	*	259.405	-53.87	-12.28	-66.15	-13.00	-53.15	peak	
5		285.110	-54.63	-11.81	-66.44	-13.00	-53.44	peak	
6		363.195	-59.67	-9.89	-69.56	-13.00	-56.56	peak	

Test Mode | LTE Band 26\_TX CH26740\_5M\_Second Antenna

### Vertical

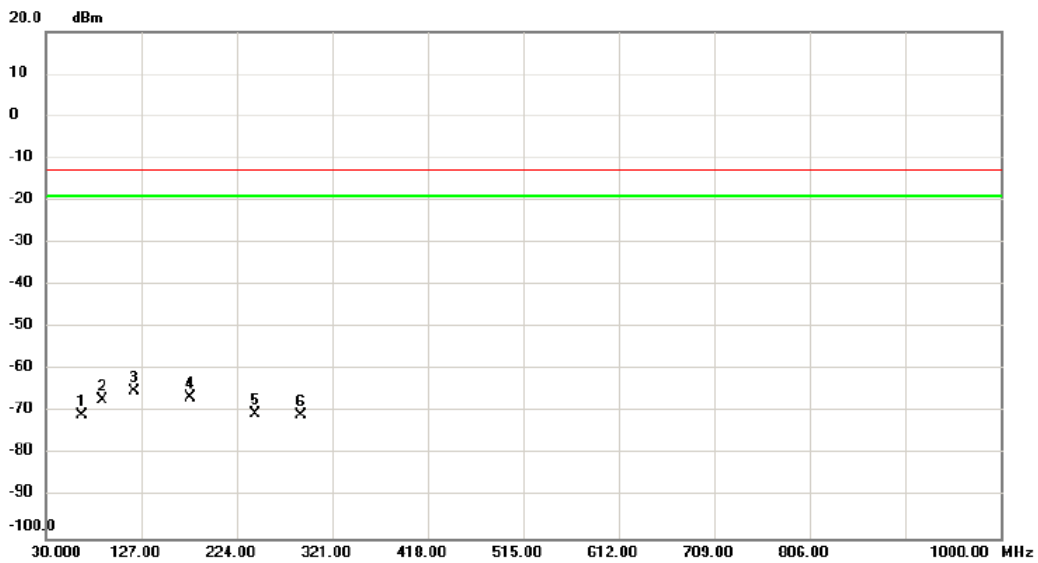

No.	Mk.	Freq. MHz	Reading Level dBm	Correct Factor dB	Measure- ment dBm	Limit dBm	Margin dB	Detector	Comment
1		66.860	-55.60	-15.25	-70.85	-13.00	-57.85	peak	
2		87.715	-50.81	-16.20	-67.01	-13.00	-54.01	peak	
3	*	119.725	-52.29	-12.78	-65.07	-13.00	-52.07	peak	
4		176.470	-53.90	-12.54	-66.44	-13.00	-53.44	peak	
5		242.915	-57.03	-13.50	-70.53	-13.00	-57.53	peak	
6		289.960	-59.19	-11.48	-70.67	-13.00	-57.67	peak	

Test Mode | LTE Band 26\_TX CH26740\_5M\_Second Antenna

### Horizontal

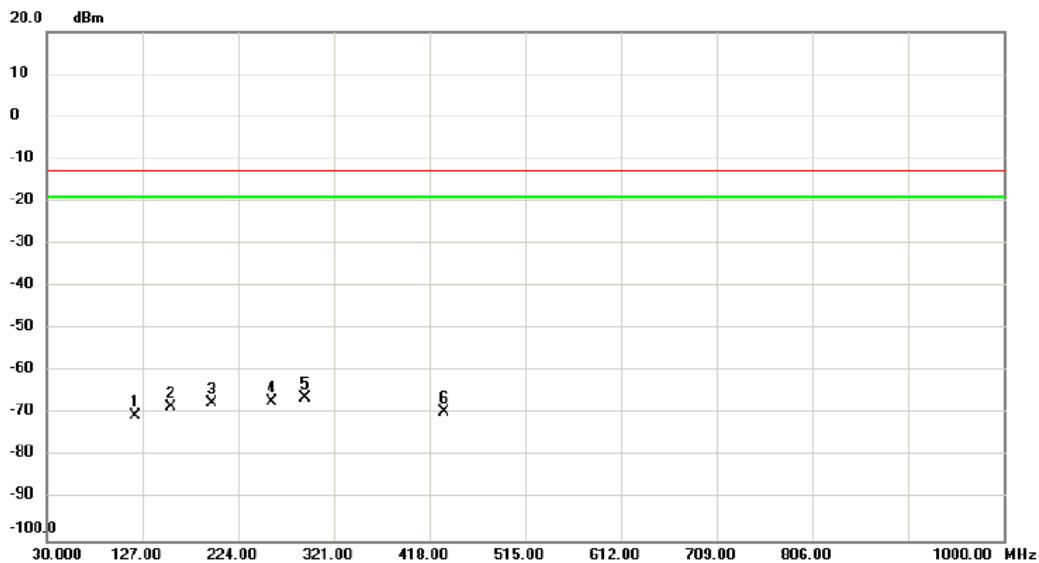

No.	Mk.	Freq. MHz	Reading Level dBm	Correct Factor dB	Measure- ment dBm	Limit dBm	Margin dB	Detector	Comment
1		119.240	-57.72	-12.85	-70.57	-13.00	-57.57	peak	
2		156.100	-57.18	-11.18	-68.36	-13.00	-55.36	peak	
3		197.325	-52.97	-14.62	-67.59	-13.00	-54.59	peak	
4		258.435	-54.76	-12.40	-67.16	-13.00	-54.16	peak	
5	*	291.415	-54.74	-11.41	-66.15	-13.00	-53.15	peak	
6		433.035	-61.55	-8.11	-69.66	-13.00	-56.66	peak	

Test Mode LTE Band 26\_TX CH26740\_10M\_Second Antenna

### Vertical

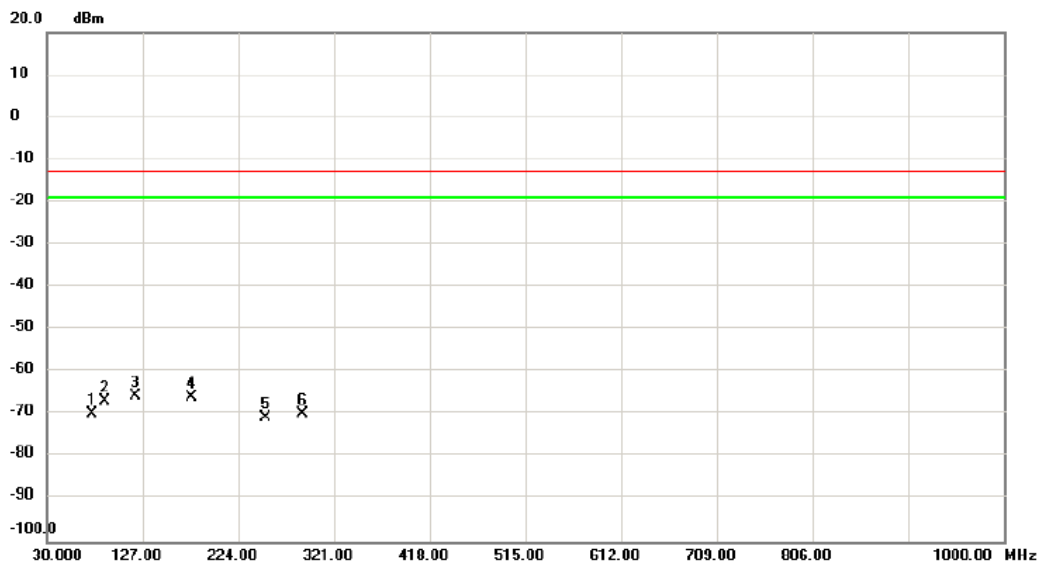

No.	Mk.	Freq. MHz	Reading Level dBm	Correct Factor dB	Measure- ment dBm	Limit dBm	Margin dB	Detector	Comment
1		75.590	-52.97	-16.96	-69.93	-13.00	-56.93	peak	
2		89.170	-51.04	-15.90	-66.94	-13.00	-53.94	peak	
3	*	119.725	-53.02	-12.78	-65.80	-13.00	-52.80	peak	
4		176.470	-53.47	-12.54	-66.01	-13.00	-53.01	peak	
5		251.645	-57.56	-13.13	-70.69	-13.00	-57.69	peak	
6		289.960	-58.48	-11.48	-69.96	-13.00	-56.96	peak	

Test Mode | LTE Band 26\_TX CH26740\_10M\_Second Antenna

### Horizontal

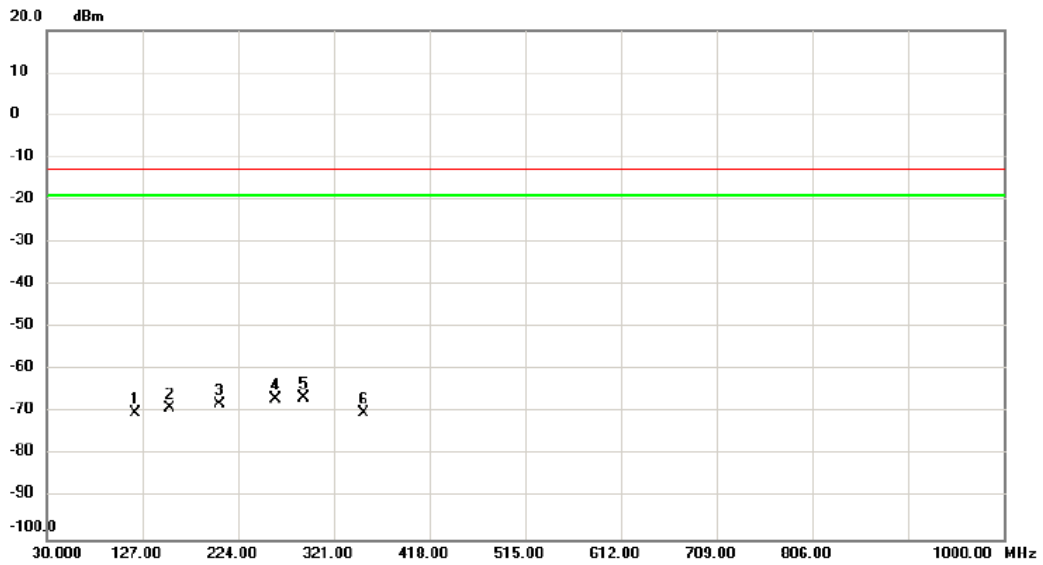

No.	Mk.	Freq. MHz	Reading Level dBm	Correct Factor dB	Measure- ment dBm	Limit dBm	Margin dB	Detector	Comment
1		119.240	-57.40	-12.85	-70.25	-13.00	-57.25	peak	
2		154.645	-57.70	-11.36	-69.06	-13.00	-56.06	peak	
3		204.600	-52.92	-15.00	-67.92	-13.00	-54.92	peak	
4		262.315	-54.59	-12.32	-66.91	-13.00	-53.91	peak	
5	*	290.930	-55.04	-11.44	-66.48	-13.00	-53.48	peak	
6		351.070	-60.05	-10.17	-70.22	-13.00	-57.22	peak	

## **APPENDIX F - RADIATED SPURIOUS EMISSIONS (ABOVE 1000MHZ)**

Test Mode | LTE Band 26\_TX CH26740\_1.4M\_Main Antenna

### Vertical

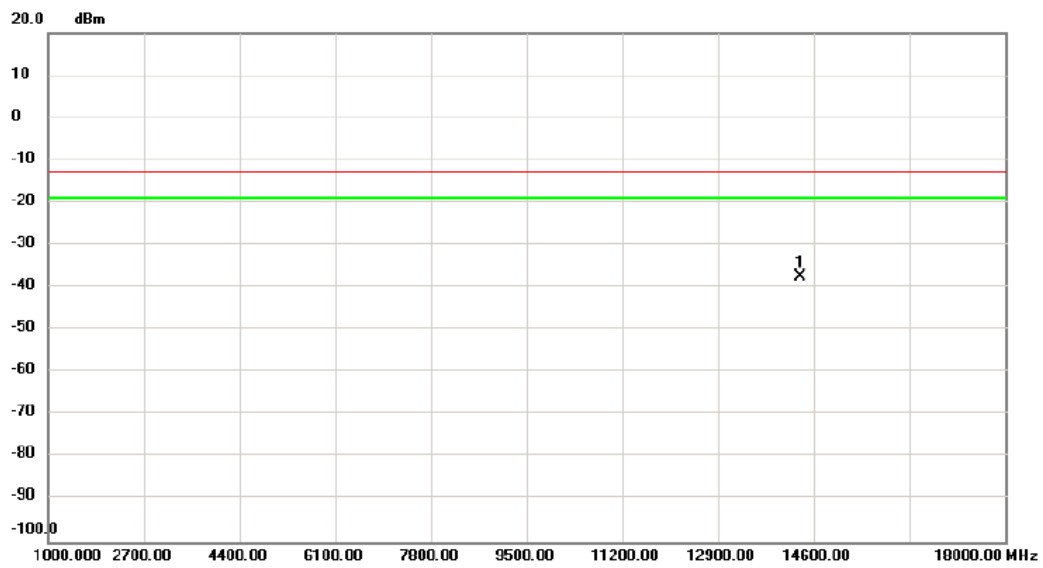

No.	Mk.	Freq.	Reading Level	Correct Factor	Measurement	Limit	Margin	Detector	Comment
		MHz	dBm	dB	dBm	dBm	dB		
1	*	14362.000	-56.45	19.14	-37.31	-13.00	-24.31	peak	

Test Mode | LTE Band 26\_TX CH26740\_1.4M\_Main Antenna

### Horizontal

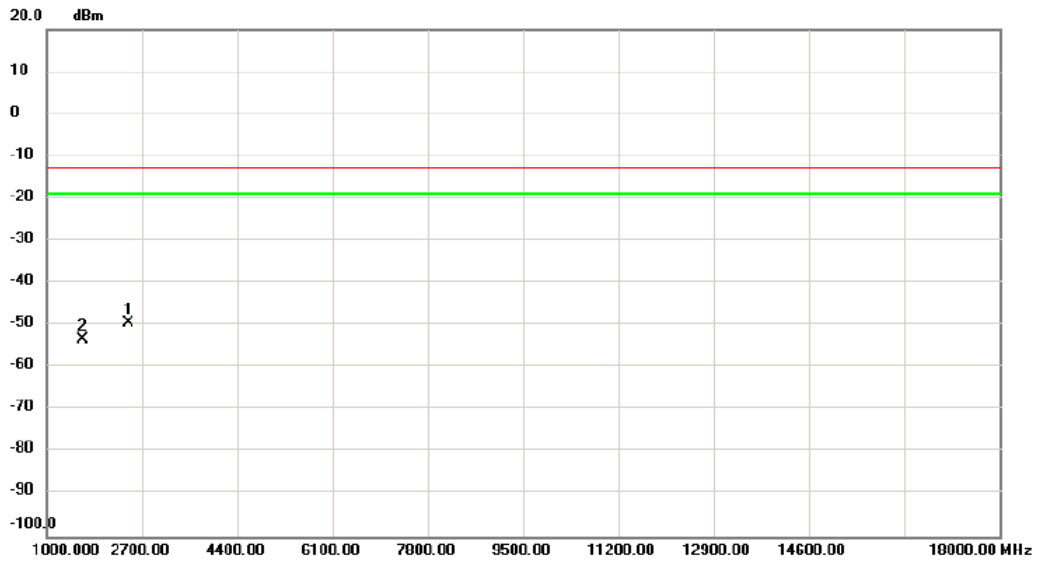

No.	Mk.	Freq. MHz	Reading Level dBm	Correct Factor dB	Measure- ment dBm	Limit dBm	Margin dB	Detector	Comment
1	*	2453.500	-47.69	-1.65	-49.34	-13.00	-36.34	peak	
2		1637.500	-49.20	-4.27	-53.47	-13.00	-40.47	peak	



Test Mode | LTE Band 26\_TX CH26740\_5M\_Main Antenna

### Vertical

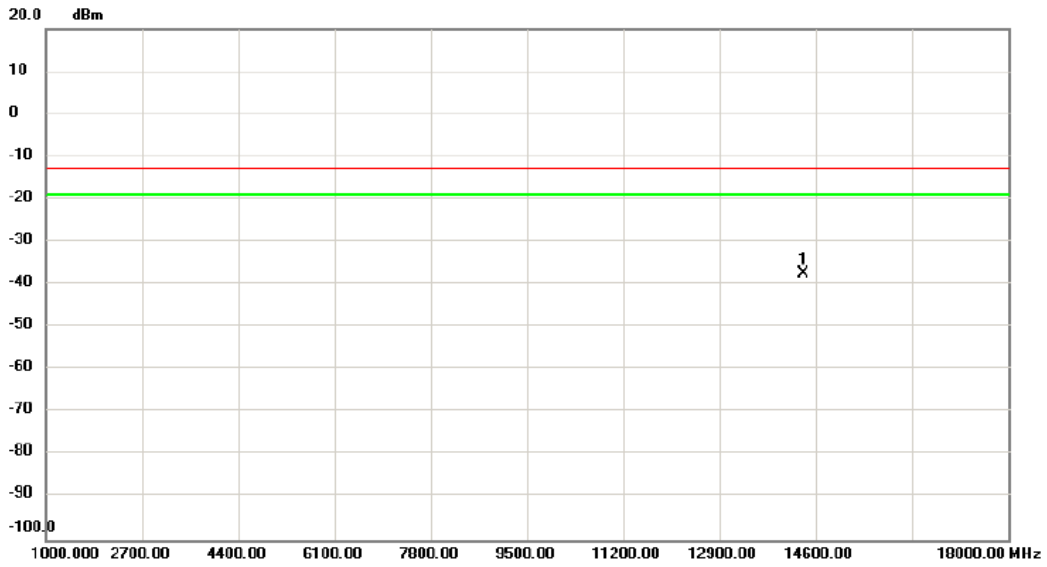

No.	Mk.	Freq. MHz	Reading Level dBm	Correct Factor dB	Measure- ment dBm	Limit dBm	Margin dB	Detector	Comment
1	*	14379.000	-56.73	19.14	-37.59	-13.00	-24.59	peak	

Test Mode | LTE Band 26\_TX CH26740\_5M\_Main Antenna

### Horizontal

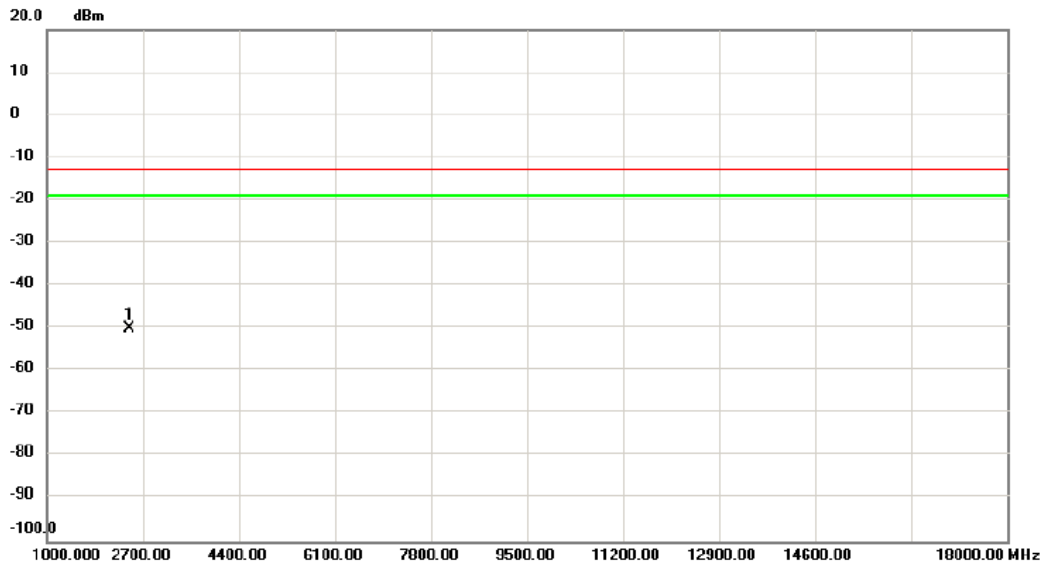

No.	Mk.	Freq.	Reading Level	Correct Factor	Measurement	Limit	Margin	Detector	Comment
		MHz	dBm	dB	dBm	dBm	dB		
1	*	2453.500	-48.48	-1.65	-50.13	-13.00	-37.13	peak	

Test Mode | LTE Band 26\_TX CH26740\_10M\_Main Antenna

### Vertical

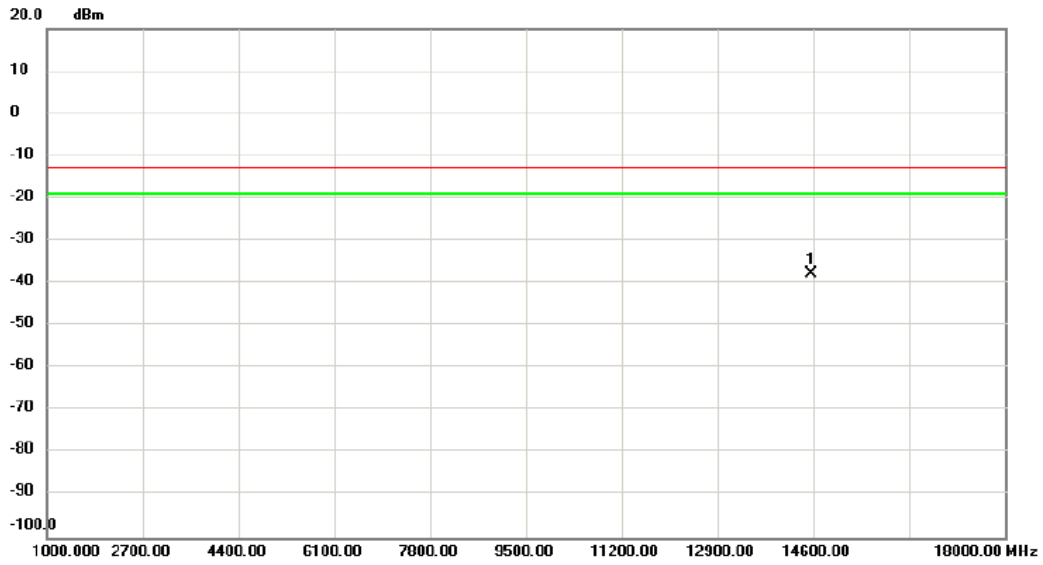

No.	Mk.	Freq.	Reading Level	Correct Factor	Measurement	Limit	Margin	Detector	Comment
		MHz	dBm	dB	dBm	dBm	dB		
1	*	14566.000	-56.58	18.91	-37.67	-13.00	-24.67	peak	

Test Mode | LTE Band 26\_TX CH26740\_10M\_Main Antenna

### Horizontal

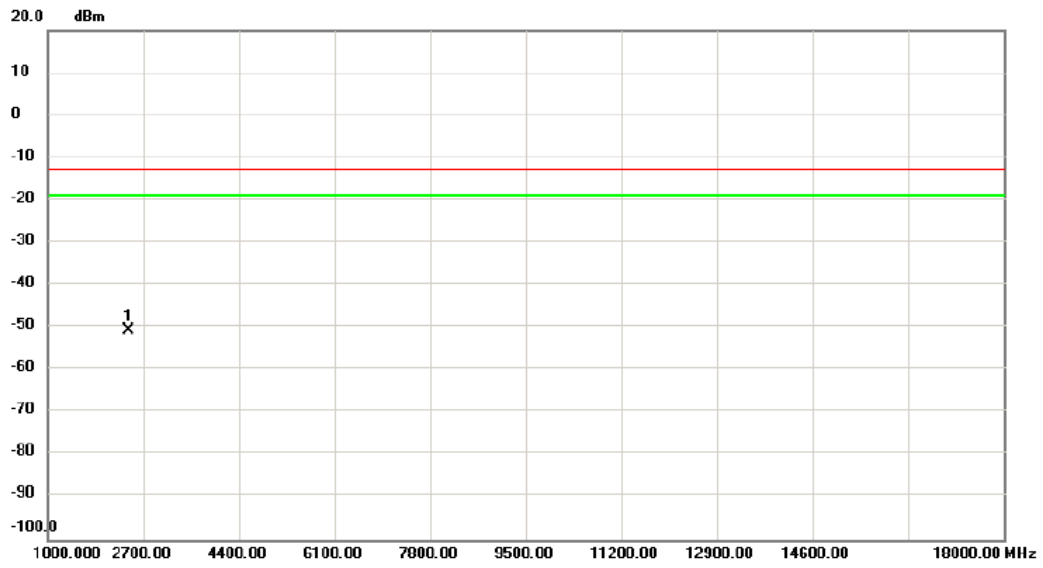

No.	Mk.	Freq. MHz	Reading Level dBm	Correct Factor dB	Measure- ment dBm	Limit dBm	Margin dB	Detector	Comment
1	*	2445.000	-49.02	-1.66	-50.68	-13.00	-37.68	peak	

Test Mode | LTE Band 26\_TX CH26740\_1.4M\_Second Antenna

### Vertical

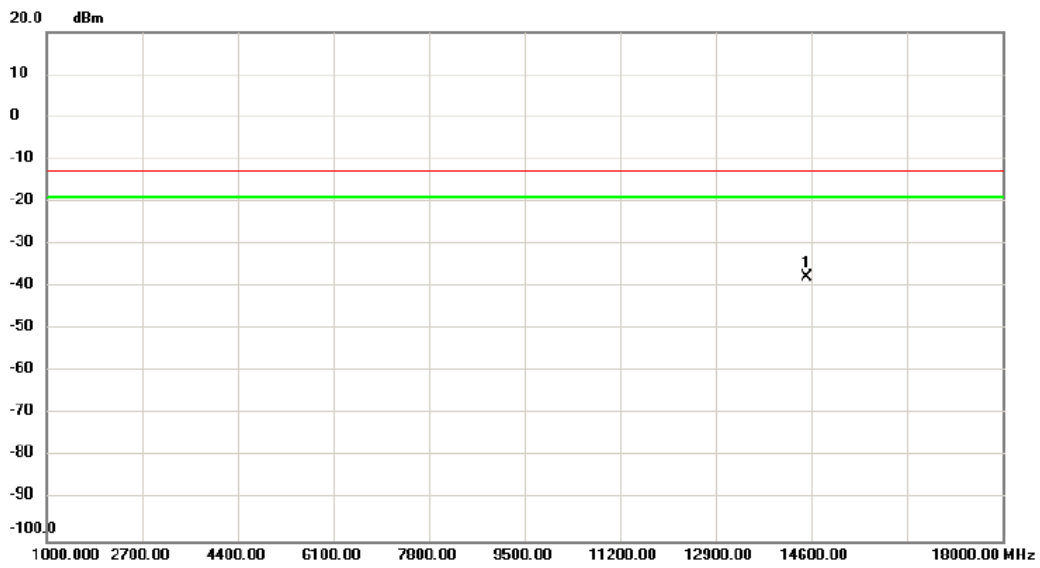

No.	Mk.	Freq.	Reading Level	Correct Factor	Measurement	Limit	Margin	Detector	Comment
		MHz	dBm	dB	dBm	dBm	dB		
1	*	14515.000	-56.87	19.06	-37.81	-13.00	-24.81	peak	

Test Mode | LTE Band 26\_TX CH26740\_1.4M\_Second Antenna

### Horizontal

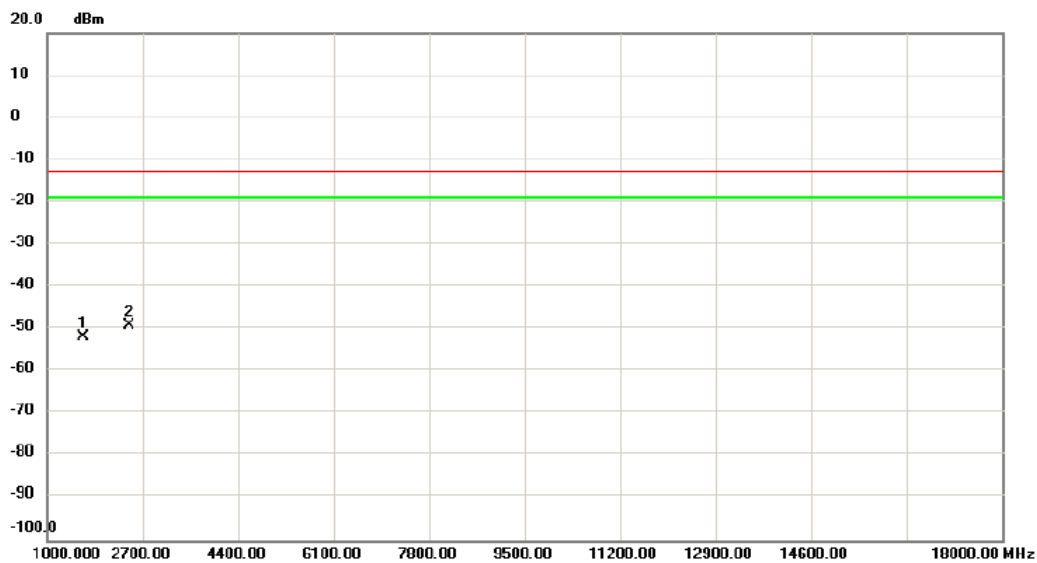

No.	Mk.	Freq. MHz	Reading Level dBm	Correct Factor dB	Measure- ment dBm	Limit dBm	Margin dB	Detector	Comment
1		1637.500	-47.57	-4.27	-51.84	-13.00	-38.84	peak	
2	*	2453.500	-47.44	-1.65	-49.09	-13.00	-36.09	peak	

Test Mode | LTE Band 26\_TX CH26740\_5M\_Second Antenna

### Vertical

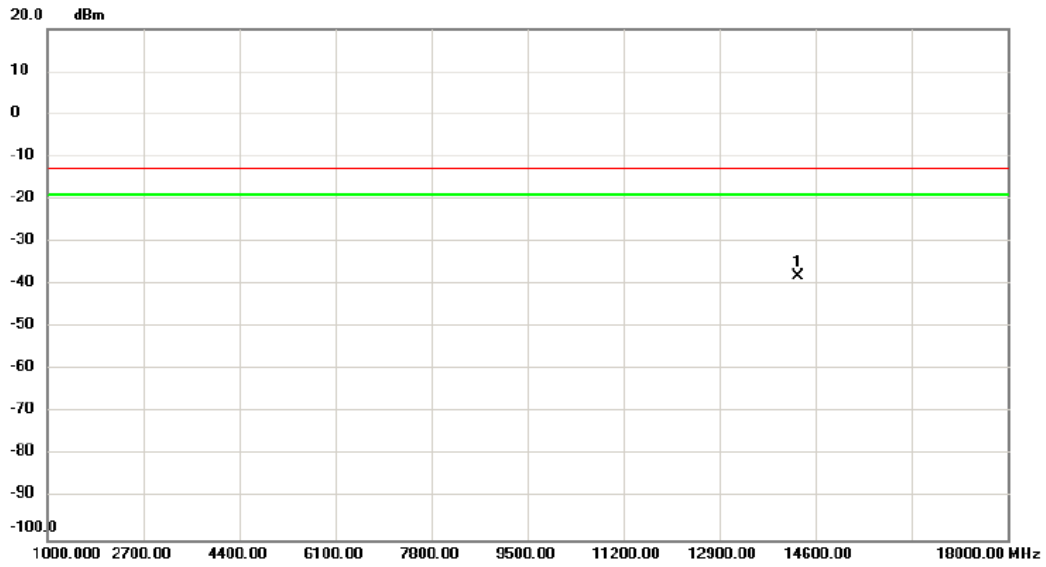

No.	Mk.	Freq.	Reading Level	Correct Factor	Measurement	Limit	Margin	Detector	Comment
		MHz	dBm	dB	dBm	dBm	dB		
1	*	14302.500	-57.27	19.16	-38.11	-13.00	-25.11	peak	

Test Mode | LTE Band 26\_TX CH26740\_5M\_Second Antenna

### Horizontal

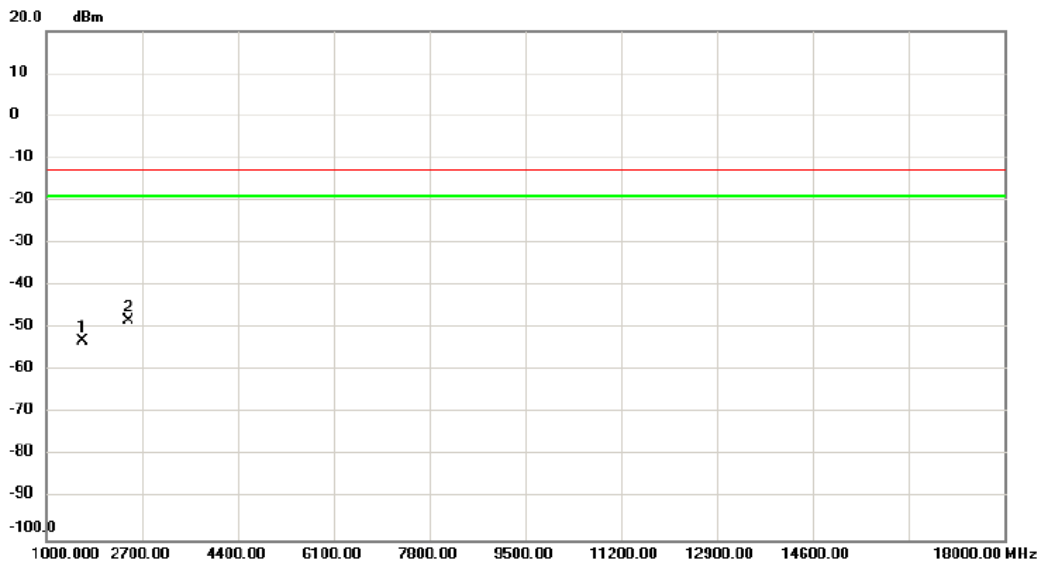

No.	Mk.	Freq. MHz	Reading Level dBm	Correct Factor dB	Measure- ment dBm	Limit dBm	Margin dB	Detector	Comment
1		1637.500	-48.87	-4.27	-53.14	-13.00	-40.14	peak	
2	*	2453.500	-46.71	-1.65	-48.36	-13.00	-35.36	peak	



Test Mode | LTE Band 26\_TX CH26740\_10M\_Second Antenna

### Vertical

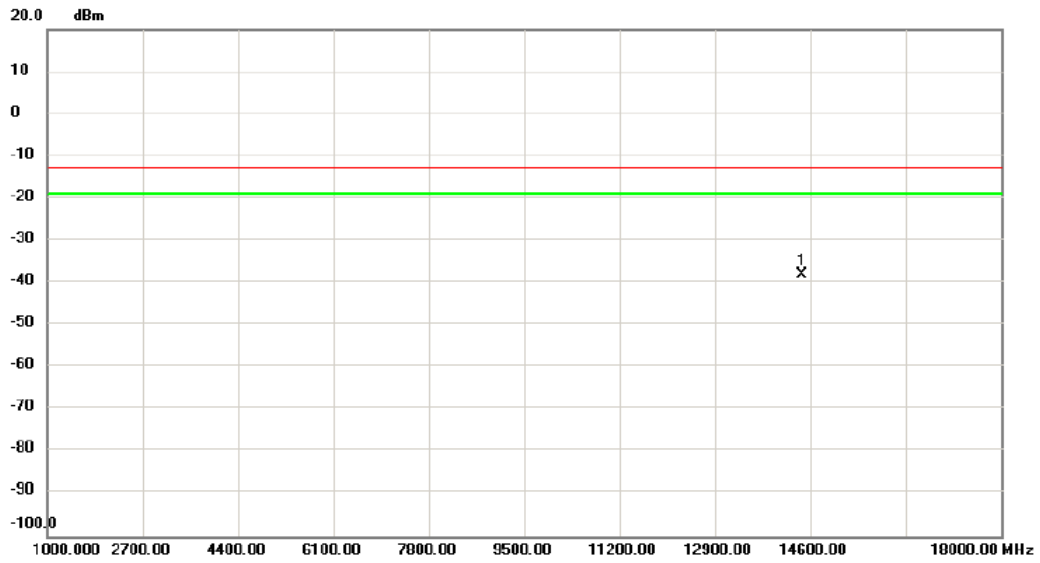

No.	Mk.	Freq. MHz	Reading Level dBm	Correct Factor dB	Measure- ment dBm	Limit dBm	Margin dB	Detector	Comment
1	*	14455.500	-57.25	19.11	-38.14	-13.00	-25.14	peak	

Test Mode | LTE Band 26\_TX CH26740\_10M\_Second Antenna

### Horizontal

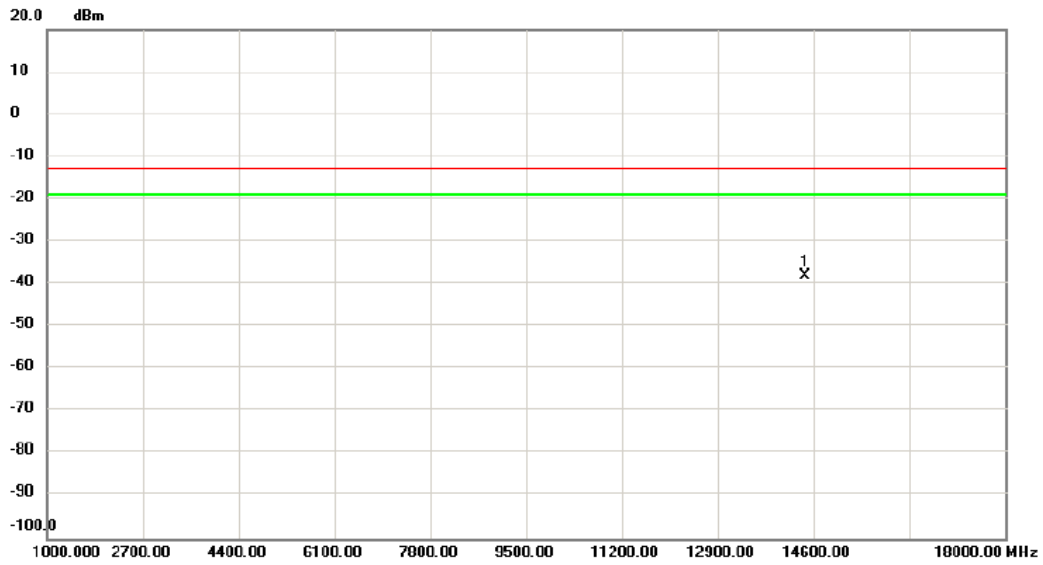

No.	Mk.	Freq. MHz	Reading Level dBm	Correct Factor dB	Measure- ment dBm	Limit dBm	Margin dB	Detector	Comment
1	*	14447.000	-57.08	19.12	-37.96	-13.00	-24.96	peak	

## APPENDIX G - MASK

## LTE Band 26\_1.4M

1RB#0

1RB#5

Channel

26697

Channel

26783

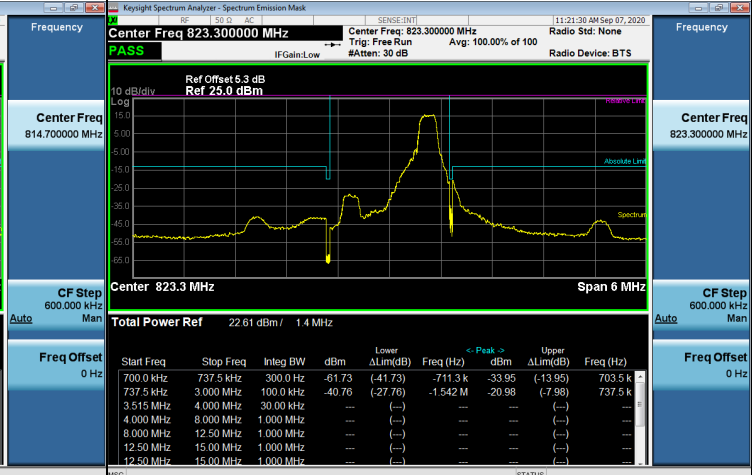
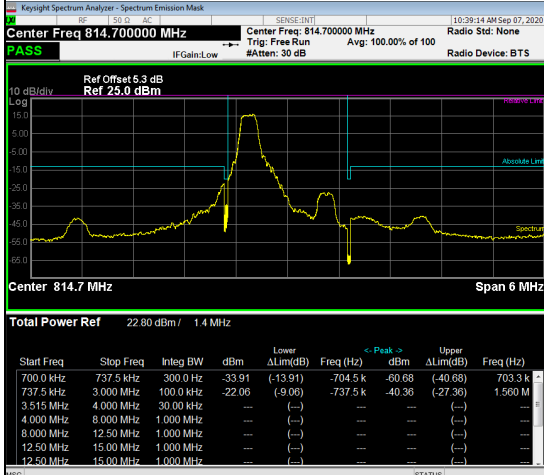

## 6RB#0

Channel

26697

Channel

26783

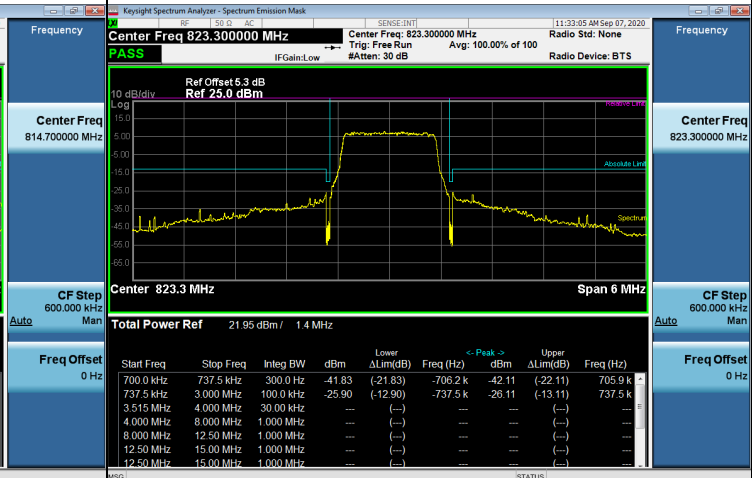
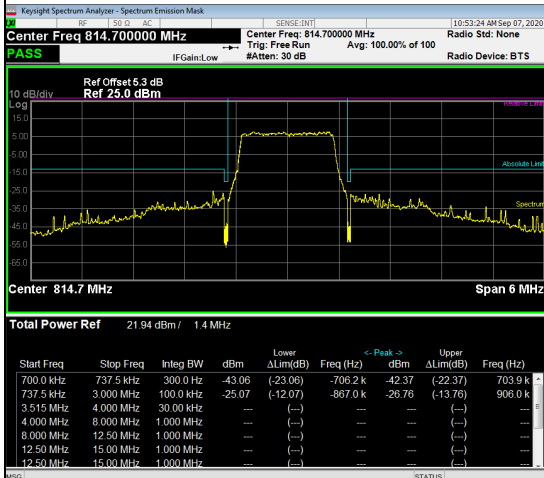

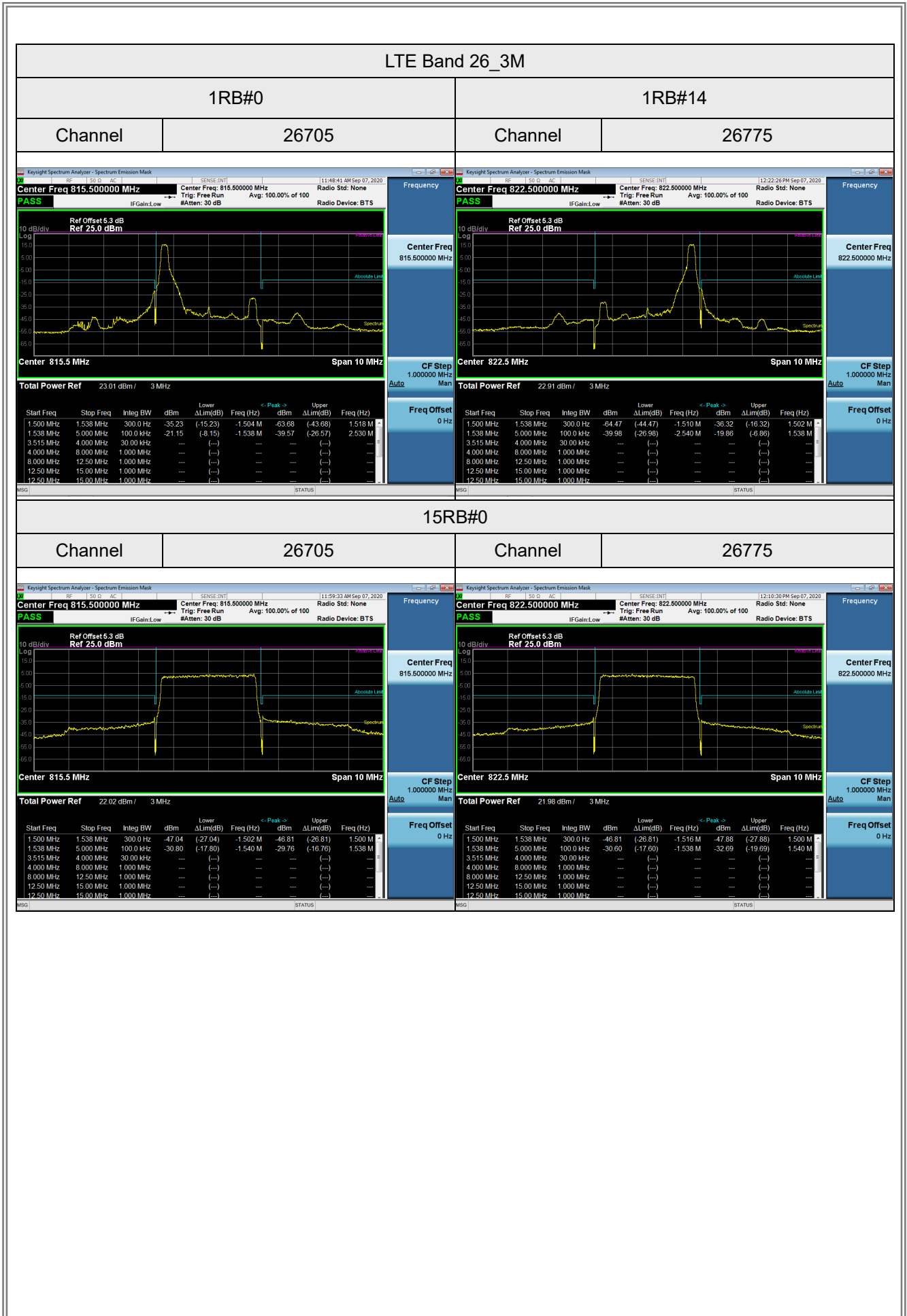

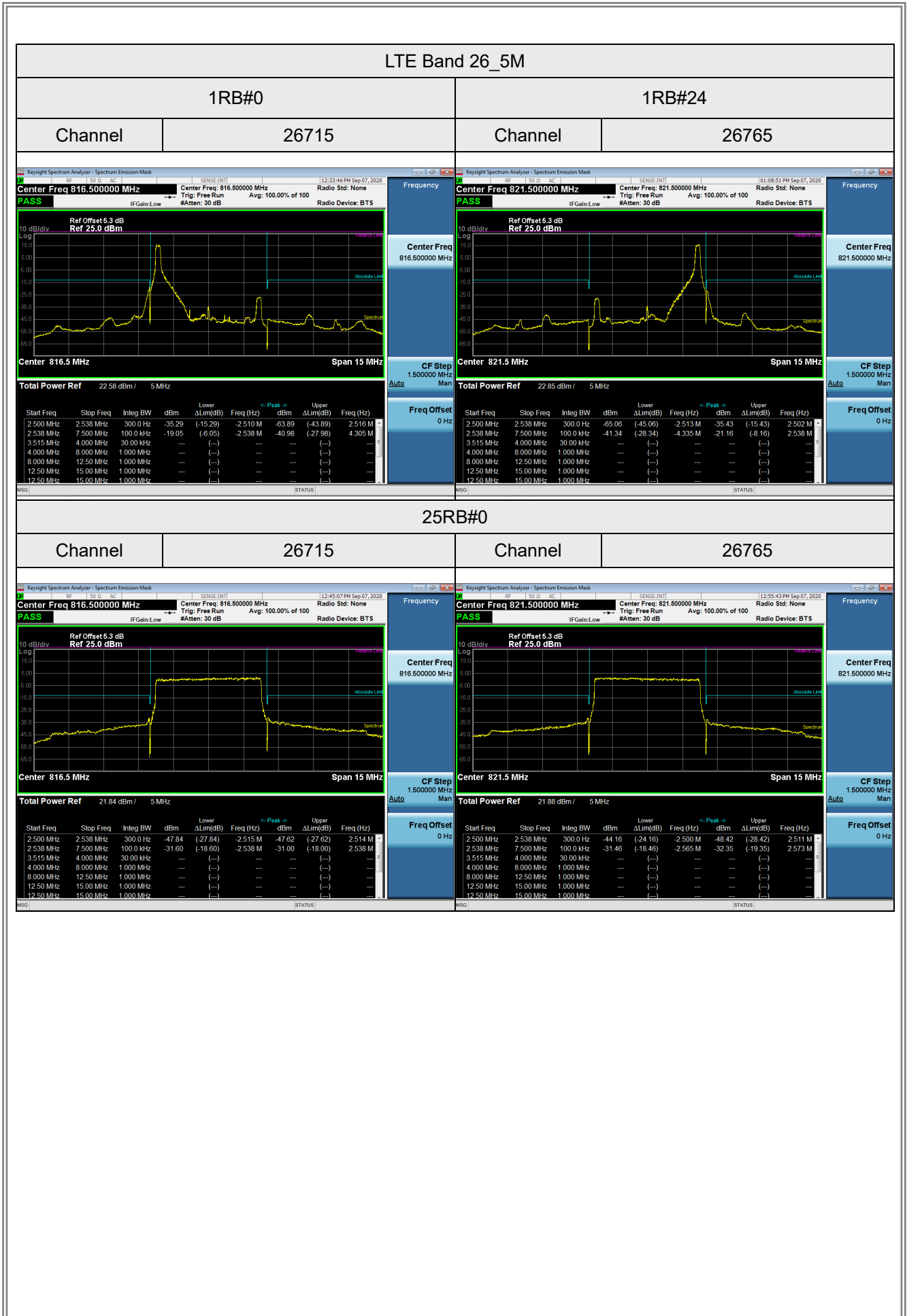

LTE Band 26_10M																																																																																																																																																			
1RB#0		1RB#49																																																																																																																																																	
Channel	26740	Channel	26740																																																																																																																																																
<table border="1"> <thead> <tr> <th>Start Freq</th> <th>Stop Freq</th> <th>Integ BW</th> <th>dBm</th> <th>Lower ΔLim(dB)</th> <th>Upper ΔLim(dB)</th> <th>Freq (Hz)</th> <th>dBm</th> <th>Upper Freq (Hz)</th> </tr> </thead> <tbody> <tr> <td>5.000 MHz</td> <td>5.038 MHz</td> <td>300.0 kHz</td> <td>-42.00</td> <td>(-22.00)</td> <td>(-49.73)</td> <td>-5.002 M</td> <td>-69.73</td> <td>5.020 M</td> </tr> <tr> <td>5.038 MHz</td> <td>10.00 MHz</td> <td>100.0 kHz</td> <td>-23.32</td> <td>(-10.32)</td> <td>(-29.41)</td> <td>-5.038 M</td> <td>-42.41</td> <td>8.810 M</td> </tr> <tr> <td>3.515 MHz</td> <td>4.000 MHz</td> <td>30.00 kHz</td> <td>---</td> <td>(--)</td> <td>(--)</td> <td>---</td> <td>(--)</td> <td>---</td> </tr> <tr> <td>4.000 MHz</td> <td>8.000 MHz</td> <td>1.000 MHz</td> <td>---</td> <td>(--)</td> <td>(--)</td> <td>---</td> <td>(--)</td> <td>---</td> </tr> <tr> <td>8.000 MHz</td> <td>12.50 MHz</td> <td>1.000 MHz</td> <td>---</td> <td>(--)</td> <td>(--)</td> <td>---</td> <td>(--)</td> <td>---</td> </tr> <tr> <td>12.50 MHz</td> <td>15.00 MHz</td> <td>1.000 MHz</td> <td>---</td> <td>(--)</td> <td>(--)</td> <td>---</td> <td>(--)</td> <td>---</td> </tr> <tr> <td>12.50 MHz</td> <td>15.00 MHz</td> <td>1.000 MHz</td> <td>---</td> <td>(--)</td> <td>(--)</td> <td>---</td> <td>(--)</td> <td>---</td> </tr> </tbody> </table>		Start Freq	Stop Freq	Integ BW	dBm	Lower ΔLim(dB)	Upper ΔLim(dB)	Freq (Hz)	dBm	Upper Freq (Hz)	5.000 MHz	5.038 MHz	300.0 kHz	-42.00	(-22.00)	(-49.73)	-5.002 M	-69.73	5.020 M	5.038 MHz	10.00 MHz	100.0 kHz	-23.32	(-10.32)	(-29.41)	-5.038 M	-42.41	8.810 M	3.515 MHz	4.000 MHz	30.00 kHz	---	(--)	(--)	---	(--)	---	4.000 MHz	8.000 MHz	1.000 MHz	---	(--)	(--)	---	(--)	---	8.000 MHz	12.50 MHz	1.000 MHz	---	(--)	(--)	---	(--)	---	12.50 MHz	15.00 MHz	1.000 MHz	---	(--)	(--)	---	(--)	---	12.50 MHz	15.00 MHz	1.000 MHz	---	(--)	(--)	---	(--)	---	<table border="1"> <thead> <tr> <th>Start Freq</th> <th>Stop Freq</th> <th>Integ BW</th> <th>dBm</th> <th>Lower ΔLim(dB)</th> <th>Upper ΔLim(dB)</th> <th>Freq (Hz)</th> <th>dBm</th> <th>Upper Freq (Hz)</th> </tr> </thead> <tbody> <tr> <td>5.000 MHz</td> <td>5.038 MHz</td> <td>300.0 kHz</td> <td>-68.17</td> <td>(-48.17)</td> <td>(-50.05 M</td> <td>-38.94</td> <td>(-18.94)</td> <td>5.012 M</td> </tr> <tr> <td>5.038 MHz</td> <td>10.00 MHz</td> <td>100.0 kHz</td> <td>-44.79</td> <td>(-31.79)</td> <td>(-8.820 M</td> <td>-22.43</td> <td>(-9.43)</td> <td>5.040 M</td> </tr> <tr> <td>3.515 MHz</td> <td>4.000 MHz</td> <td>30.00 kHz</td> <td>---</td> <td>(--)</td> <td>(--)</td> <td>---</td> <td>(--)</td> <td>---</td> </tr> <tr> <td>4.000 MHz</td> <td>8.000 MHz</td> <td>1.000 MHz</td> <td>---</td> <td>(--)</td> <td>(--)</td> <td>---</td> <td>(--)</td> <td>---</td> </tr> <tr> <td>8.000 MHz</td> <td>12.50 MHz</td> <td>1.000 MHz</td> <td>---</td> <td>(--)</td> <td>(--)</td> <td>---</td> <td>(--)</td> <td>---</td> </tr> <tr> <td>12.50 MHz</td> <td>15.00 MHz</td> <td>1.000 MHz</td> <td>---</td> <td>(--)</td> <td>(--)</td> <td>---</td> <td>(--)</td> <td>---</td> </tr> <tr> <td>12.50 MHz</td> <td>15.00 MHz</td> <td>1.000 MHz</td> <td>---</td> <td>(--)</td> <td>(--)</td> <td>---</td> <td>(--)</td> <td>---</td> </tr> </tbody> </table>		Start Freq	Stop Freq	Integ BW	dBm	Lower ΔLim(dB)	Upper ΔLim(dB)	Freq (Hz)	dBm	Upper Freq (Hz)	5.000 MHz	5.038 MHz	300.0 kHz	-68.17	(-48.17)	(-50.05 M	-38.94	(-18.94)	5.012 M	5.038 MHz	10.00 MHz	100.0 kHz	-44.79	(-31.79)	(-8.820 M	-22.43	(-9.43)	5.040 M	3.515 MHz	4.000 MHz	30.00 kHz	---	(--)	(--)	---	(--)	---	4.000 MHz	8.000 MHz	1.000 MHz	---	(--)	(--)	---	(--)	---	8.000 MHz	12.50 MHz	1.000 MHz	---	(--)	(--)	---	(--)	---	12.50 MHz	15.00 MHz	1.000 MHz	---	(--)	(--)	---	(--)	---	12.50 MHz	15.00 MHz	1.000 MHz	---	(--)	(--)	---	(--)	---
Start Freq	Stop Freq	Integ BW	dBm	Lower ΔLim(dB)	Upper ΔLim(dB)	Freq (Hz)	dBm	Upper Freq (Hz)																																																																																																																																											
5.000 MHz	5.038 MHz	300.0 kHz	-42.00	(-22.00)	(-49.73)	-5.002 M	-69.73	5.020 M																																																																																																																																											
5.038 MHz	10.00 MHz	100.0 kHz	-23.32	(-10.32)	(-29.41)	-5.038 M	-42.41	8.810 M																																																																																																																																											
3.515 MHz	4.000 MHz	30.00 kHz	---	(--)	(--)	---	(--)	---																																																																																																																																											
4.000 MHz	8.000 MHz	1.000 MHz	---	(--)	(--)	---	(--)	---																																																																																																																																											
8.000 MHz	12.50 MHz	1.000 MHz	---	(--)	(--)	---	(--)	---																																																																																																																																											
12.50 MHz	15.00 MHz	1.000 MHz	---	(--)	(--)	---	(--)	---																																																																																																																																											
12.50 MHz	15.00 MHz	1.000 MHz	---	(--)	(--)	---	(--)	---																																																																																																																																											
Start Freq	Stop Freq	Integ BW	dBm	Lower ΔLim(dB)	Upper ΔLim(dB)	Freq (Hz)	dBm	Upper Freq (Hz)																																																																																																																																											
5.000 MHz	5.038 MHz	300.0 kHz	-68.17	(-48.17)	(-50.05 M	-38.94	(-18.94)	5.012 M																																																																																																																																											
5.038 MHz	10.00 MHz	100.0 kHz	-44.79	(-31.79)	(-8.820 M	-22.43	(-9.43)	5.040 M																																																																																																																																											
3.515 MHz	4.000 MHz	30.00 kHz	---	(--)	(--)	---	(--)	---																																																																																																																																											
4.000 MHz	8.000 MHz	1.000 MHz	---	(--)	(--)	---	(--)	---																																																																																																																																											
8.000 MHz	12.50 MHz	1.000 MHz	---	(--)	(--)	---	(--)	---																																																																																																																																											
12.50 MHz	15.00 MHz	1.000 MHz	---	(--)	(--)	---	(--)	---																																																																																																																																											
12.50 MHz	15.00 MHz	1.000 MHz	---	(--)	(--)	---	(--)	---																																																																																																																																											
50RB#0		-																																																																																																																																																	
Channel	26740		-																																																																																																																																																
		-																																																																																																																																																	
<table border="1"> <thead> <tr> <th>Start Freq</th> <th>Stop Freq</th> <th>Integ BW</th> <th>dBm</th> <th>Lower ΔLim(dB)</th> <th>Upper ΔLim(dB)</th> <th>Freq (Hz)</th> <th>dBm</th> <th>Upper Freq (Hz)</th> </tr> </thead> <tbody> <tr> <td>5.000 MHz</td> <td>5.038 MHz</td> <td>300.0 kHz</td> <td>-53.81</td> <td>(-33.81)</td> <td>(-35.68)</td> <td>-5.029 M</td> <td>-55.68</td> <td>5.036 M</td> </tr> <tr> <td>5.038 MHz</td> <td>10.00 MHz</td> <td>100.0 kHz</td> <td>-35.76</td> <td>(-22.76)</td> <td>(-35.66)</td> <td>-5.038 M</td> <td>-35.66</td> <td>5.180 M</td> </tr> <tr> <td>3.515 MHz</td> <td>4.000 MHz</td> <td>30.00 kHz</td> <td>---</td> <td>(--)</td> <td>(--)</td> <td>---</td> <td>(--)</td> <td>---</td> </tr> <tr> <td>4.000 MHz</td> <td>8.000 MHz</td> <td>1.000 MHz</td> <td>---</td> <td>(--)</td> <td>(--)</td> <td>---</td> <td>(--)</td> <td>---</td> </tr> <tr> <td>8.000 MHz</td> <td>12.50 MHz</td> <td>1.000 MHz</td> <td>---</td> <td>(--)</td> <td>(--)</td> <td>---</td> <td>(--)</td> <td>---</td> </tr> <tr> <td>12.50 MHz</td> <td>15.00 MHz</td> <td>1.000 MHz</td> <td>---</td> <td>(--)</td> <td>(--)</td> <td>---</td> <td>(--)</td> <td>---</td> </tr> <tr> <td>12.50 MHz</td> <td>15.00 MHz</td> <td>1.000 MHz</td> <td>---</td> <td>(--)</td> <td>(--)</td> <td>---</td> <td>(--)</td> <td>---</td> </tr> </tbody> </table>		Start Freq	Stop Freq	Integ BW	dBm	Lower ΔLim(dB)	Upper ΔLim(dB)	Freq (Hz)	dBm	Upper Freq (Hz)	5.000 MHz	5.038 MHz	300.0 kHz	-53.81	(-33.81)	(-35.68)	-5.029 M	-55.68	5.036 M	5.038 MHz	10.00 MHz	100.0 kHz	-35.76	(-22.76)	(-35.66)	-5.038 M	-35.66	5.180 M	3.515 MHz	4.000 MHz	30.00 kHz	---	(--)	(--)	---	(--)	---	4.000 MHz	8.000 MHz	1.000 MHz	---	(--)	(--)	---	(--)	---	8.000 MHz	12.50 MHz	1.000 MHz	---	(--)	(--)	---	(--)	---	12.50 MHz	15.00 MHz	1.000 MHz	---	(--)	(--)	---	(--)	---	12.50 MHz	15.00 MHz	1.000 MHz	---	(--)	(--)	---	(--)	---	-																																																																									
Start Freq	Stop Freq	Integ BW	dBm	Lower ΔLim(dB)	Upper ΔLim(dB)	Freq (Hz)	dBm	Upper Freq (Hz)																																																																																																																																											
5.000 MHz	5.038 MHz	300.0 kHz	-53.81	(-33.81)	(-35.68)	-5.029 M	-55.68	5.036 M																																																																																																																																											
5.038 MHz	10.00 MHz	100.0 kHz	-35.76	(-22.76)	(-35.66)	-5.038 M	-35.66	5.180 M																																																																																																																																											
3.515 MHz	4.000 MHz	30.00 kHz	---	(--)	(--)	---	(--)	---																																																																																																																																											
4.000 MHz	8.000 MHz	1.000 MHz	---	(--)	(--)	---	(--)	---																																																																																																																																											
8.000 MHz	12.50 MHz	1.000 MHz	---	(--)	(--)	---	(--)	---																																																																																																																																											
12.50 MHz	15.00 MHz	1.000 MHz	---	(--)	(--)	---	(--)	---																																																																																																																																											
12.50 MHz	15.00 MHz	1.000 MHz	---	(--)	(--)	---	(--)	---																																																																																																																																											

## APPENDIX H - PEAK TO AVERAGE RATIO



## LTE Band 26\_1.4M Spectrum Plot

### QPSK-26697

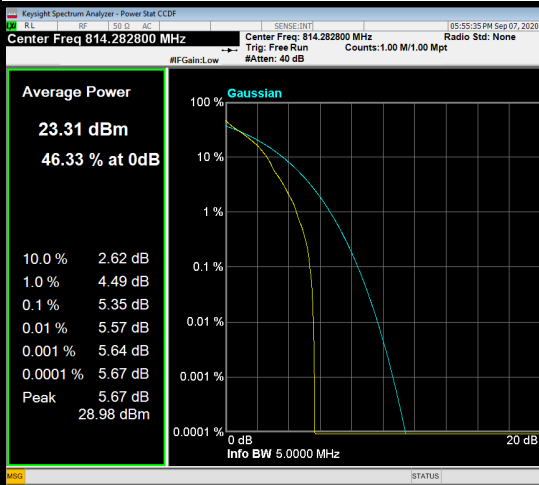

### QPSK-26740

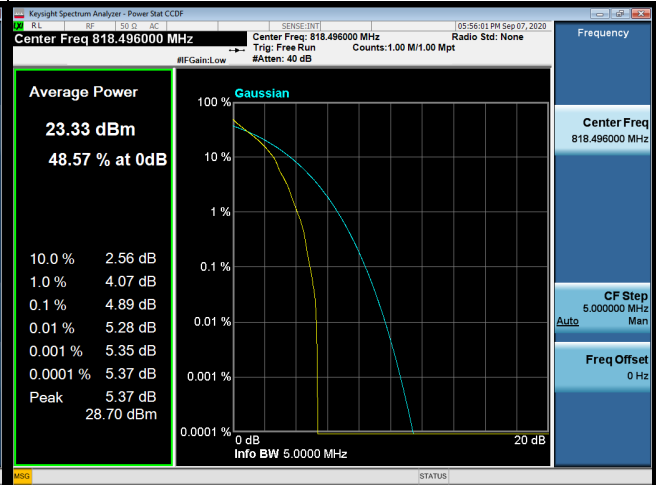

### QPSK-26783

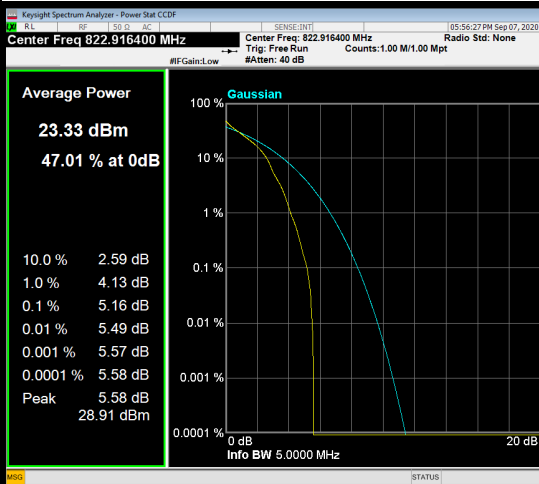

### 16QAM-26697

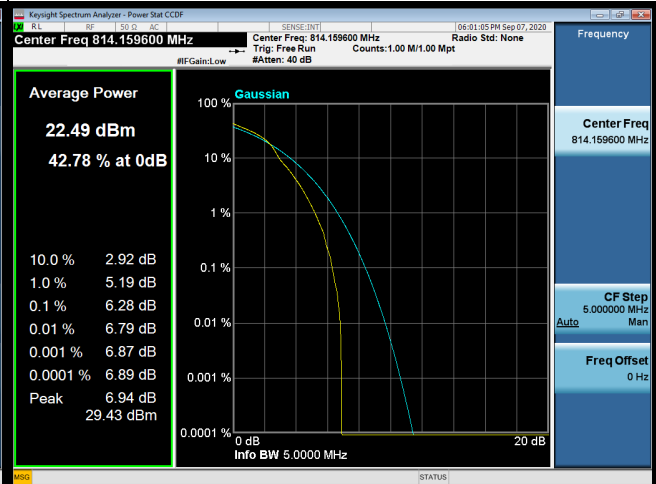

### 16QAM-26740

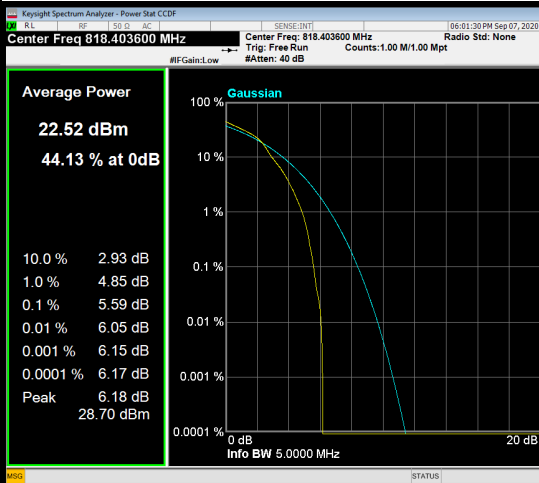

### 16QAM-26783

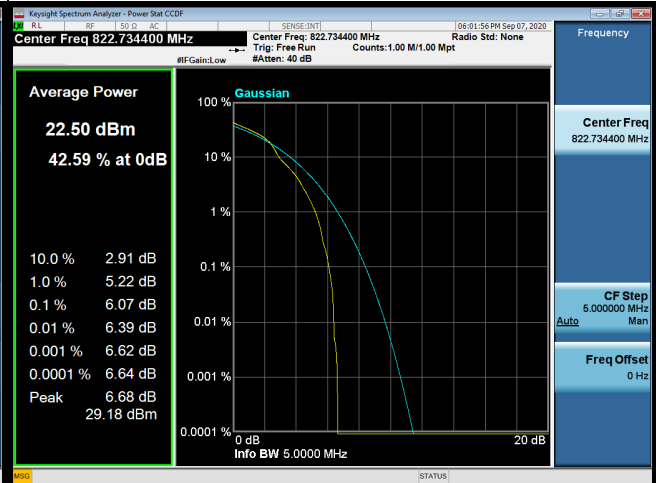

## LTE Band 26\_1.4M Spectrum Plot

64QAM-26697

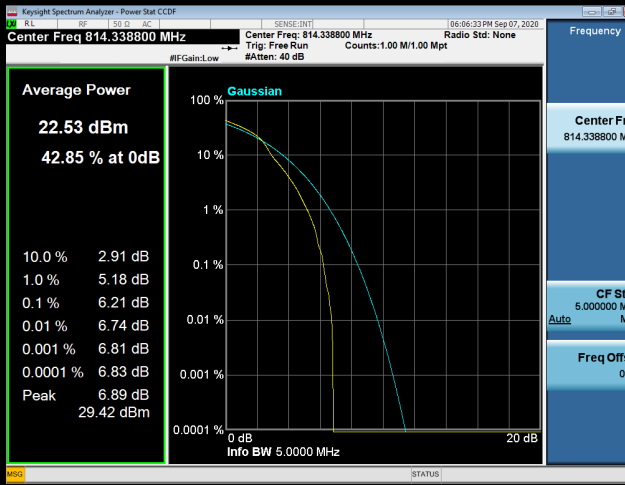

64QAM-26740

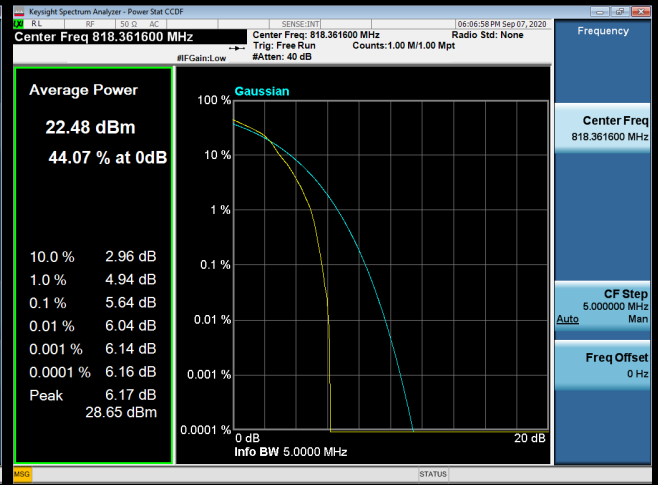

64QAM-26783

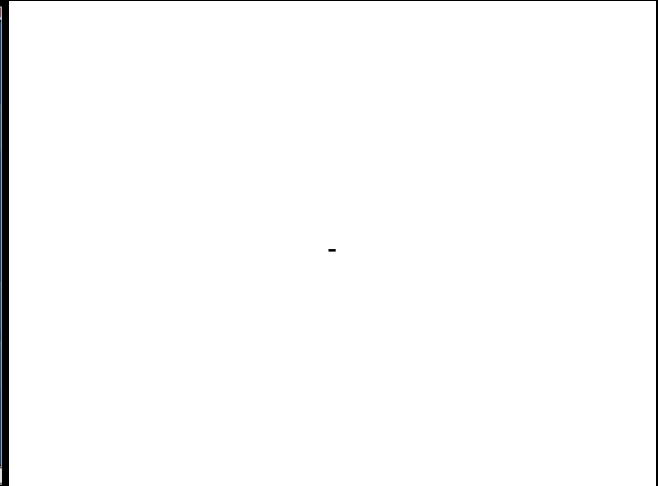
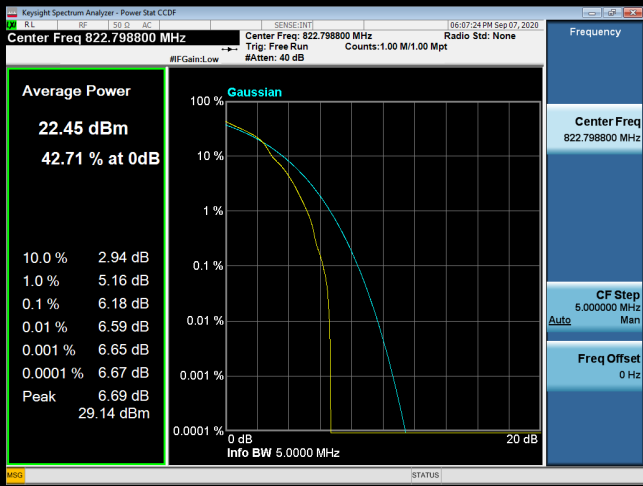

## LTE Band 26\_3M Spectrum Plot

### QPSK-26705

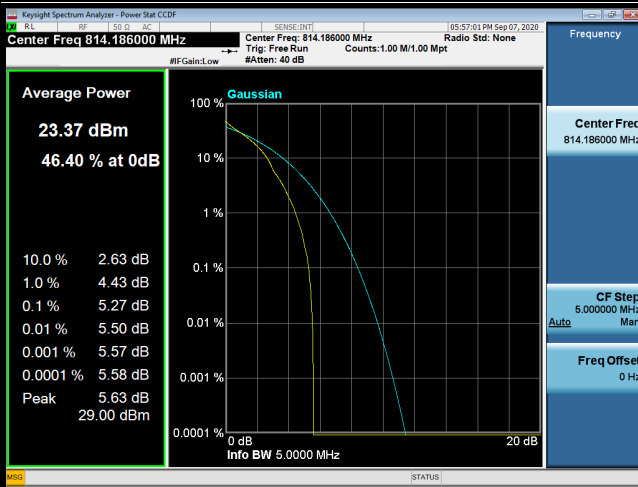

### QPSK-26740

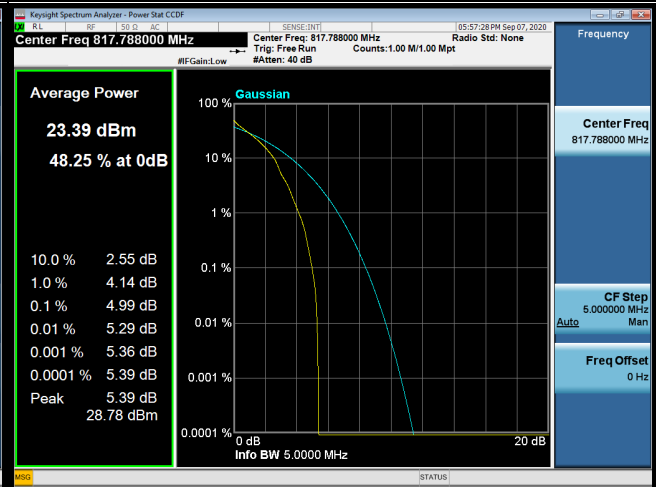

### QPSK-26775

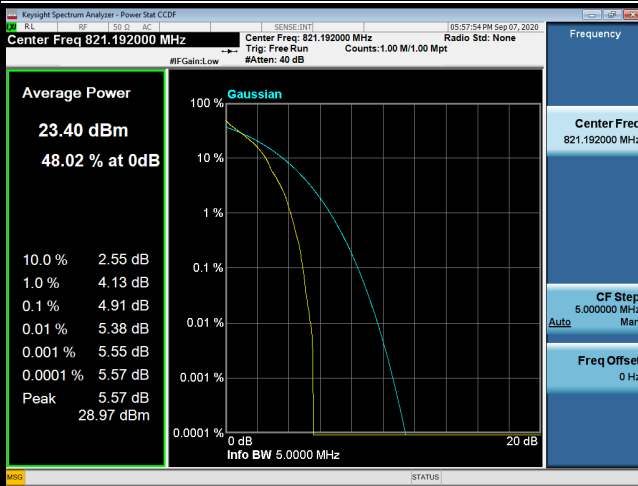

### 16QAM-26705

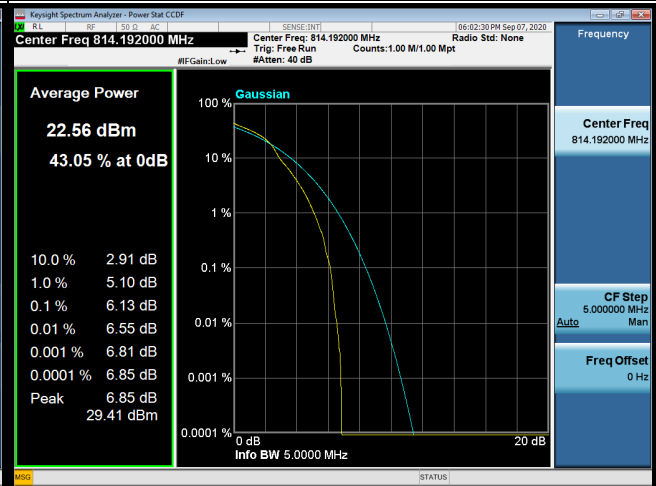

### 16QAM-26740

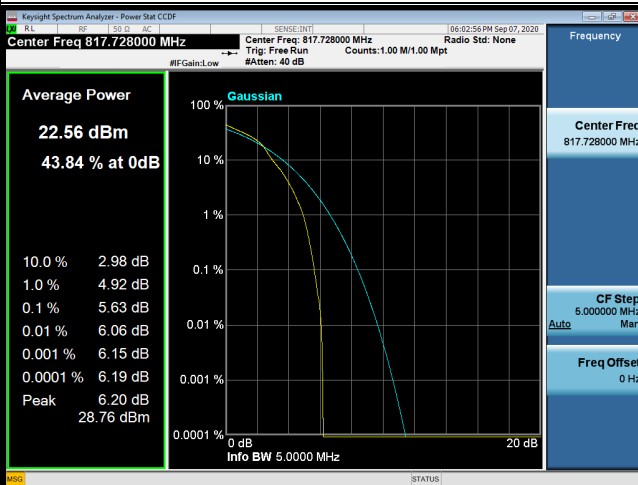

### 16QAM-26775

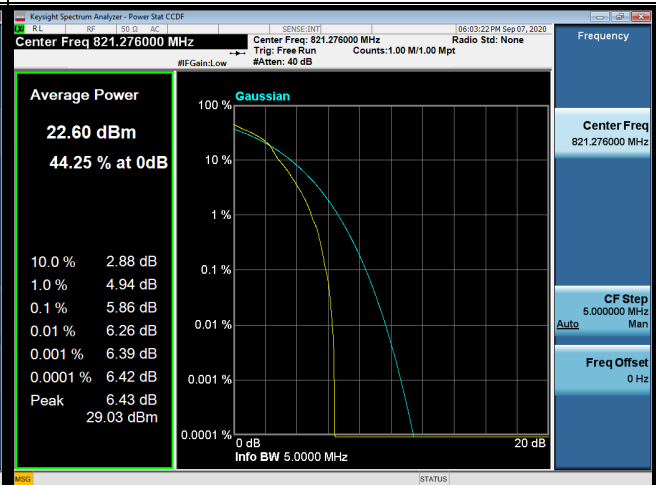

## LTE Band 26\_3M Spectrum Plot

### 64QAM-26705

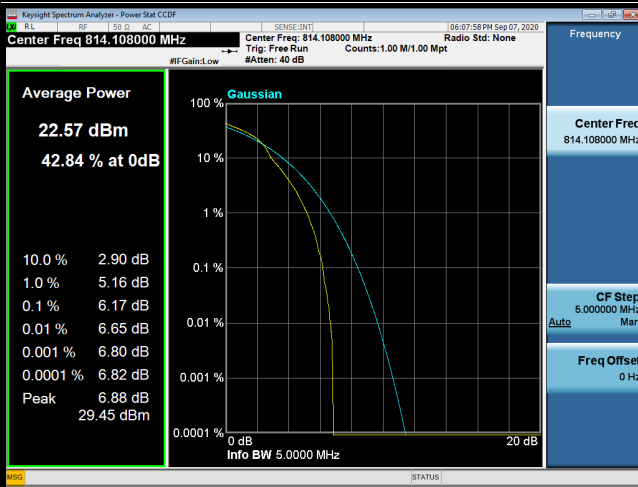

### 64QAM-26740

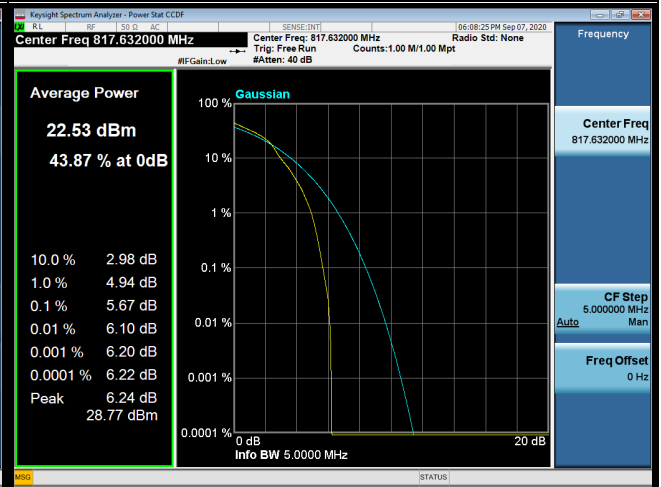

### 64QAM-26775

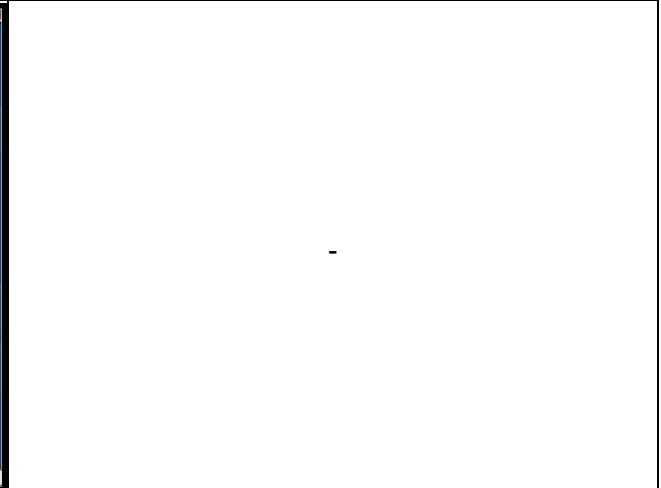
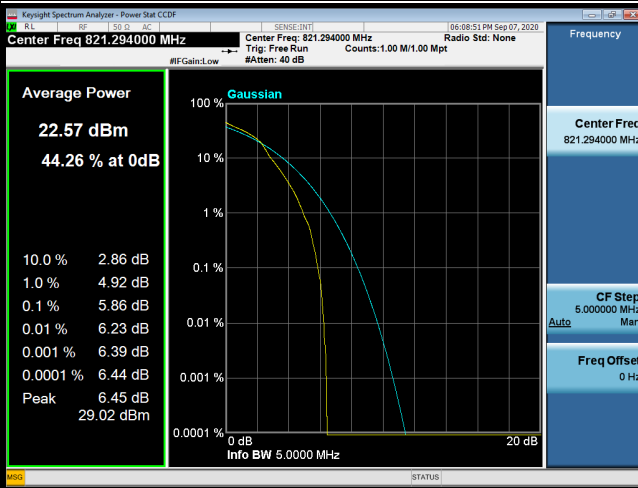

## LTE Band 26\_5M Spectrum Plot

### QPSK-26715

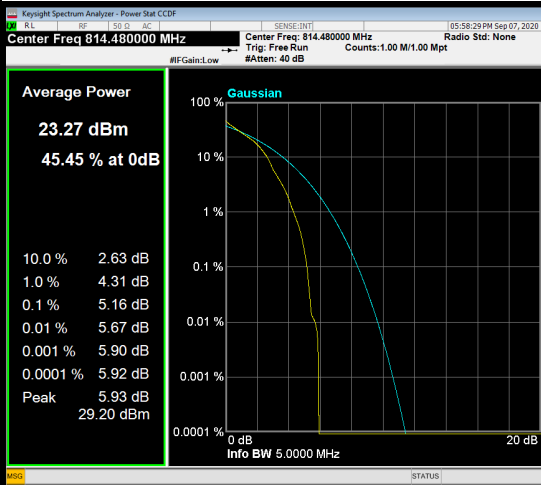

### QPSK-26740

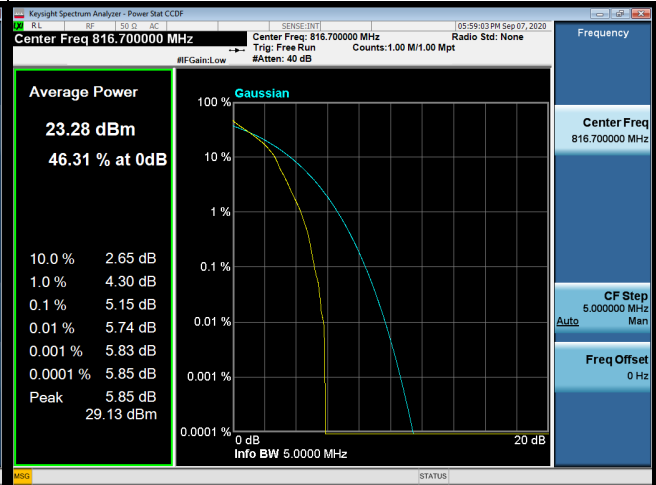

### QPSK-26765

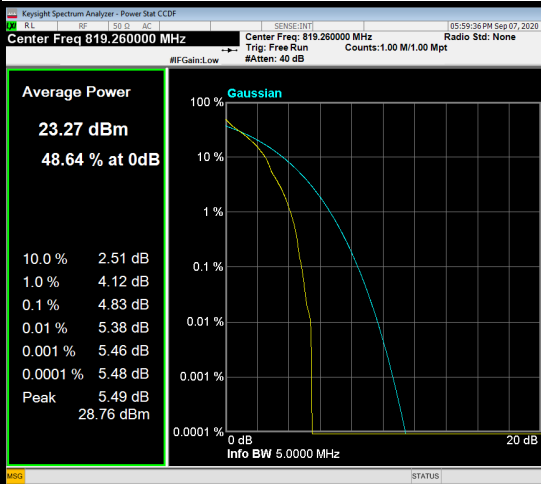

### 16QAM-26715

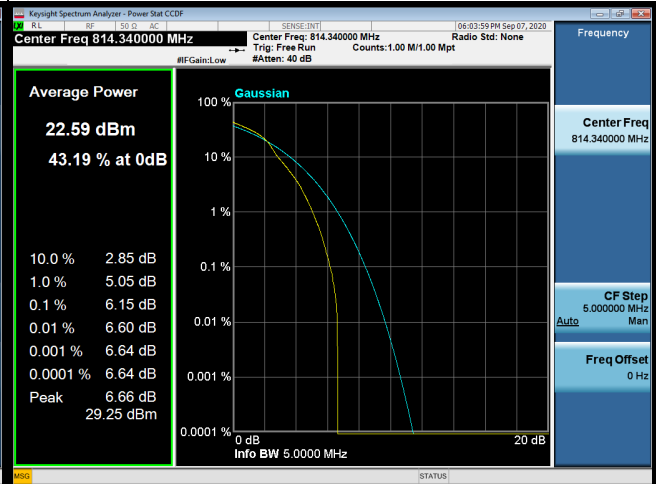

### 16QAM-26740

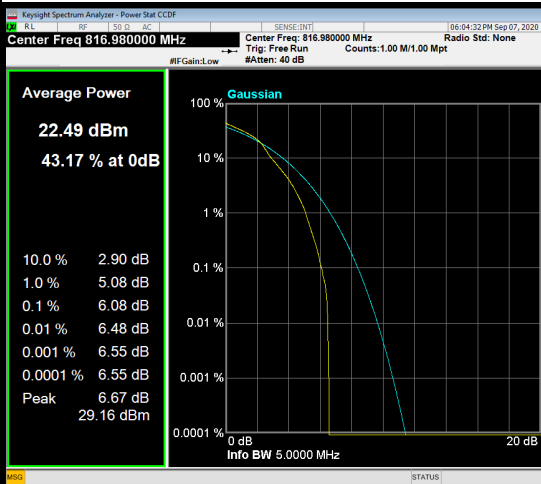

### 16QAM-26765

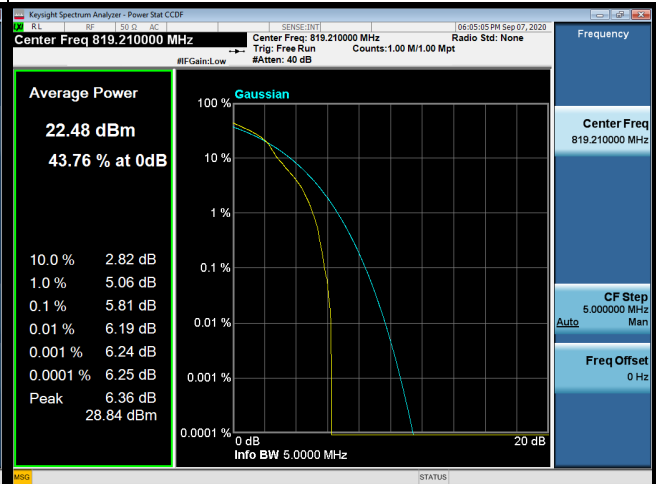

## LTE Band 26\_5M Spectrum Plot

64QAM-26715

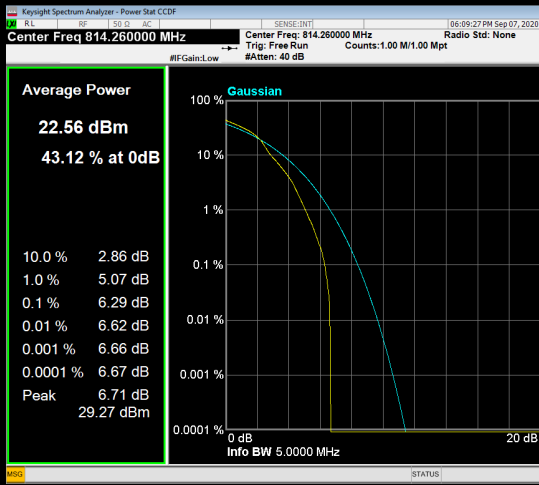

64QAM-26740

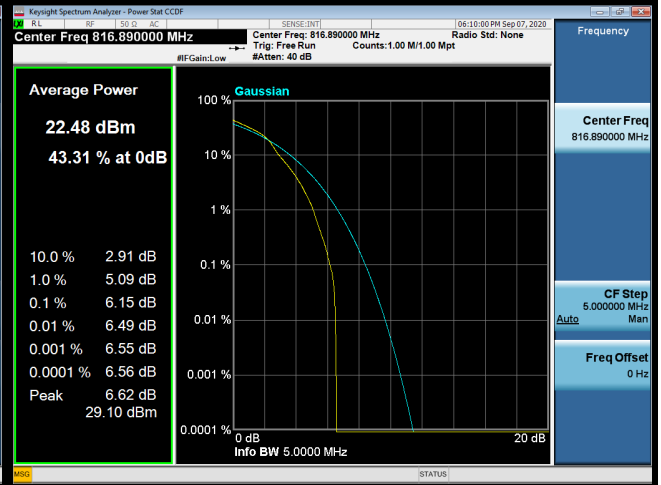

64QAM-26765

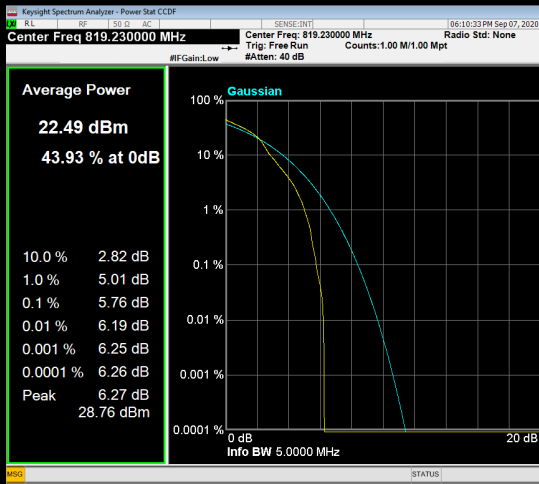

-

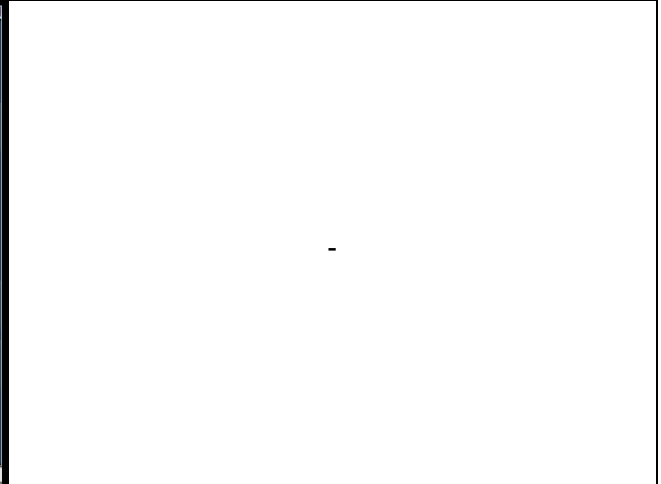

## LTE Band 26\_10M Spectrum Plot

### QPSK-26740

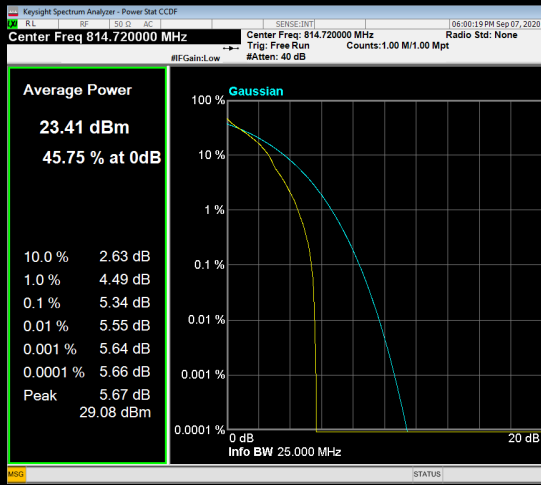

### 16QAM-26740

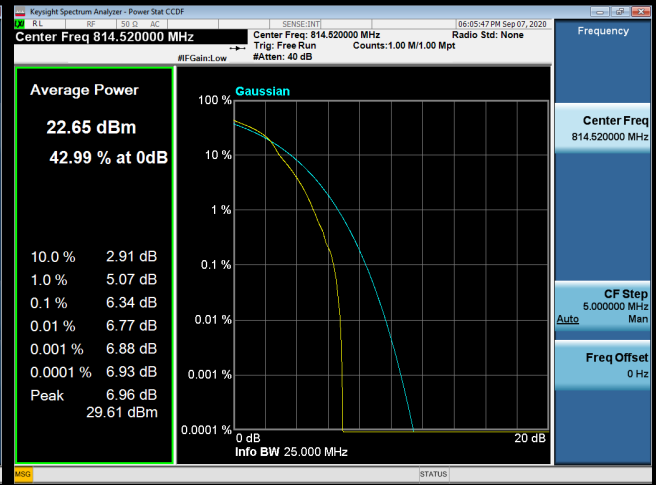

### 64QAM-26740

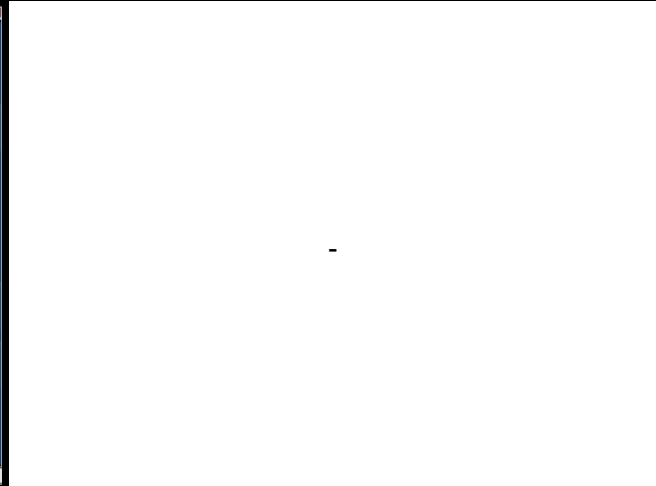
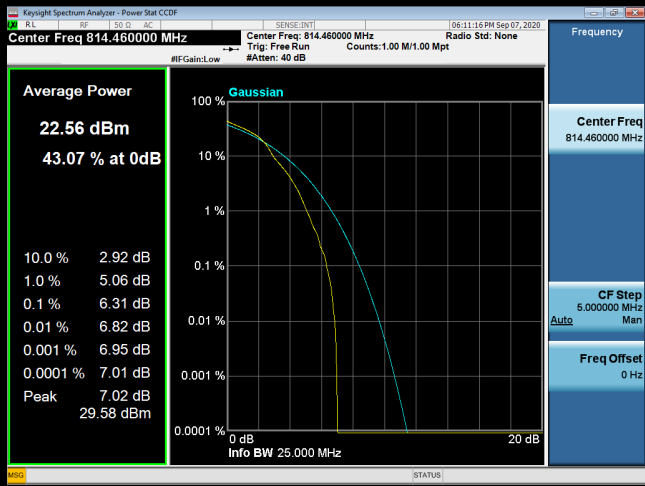

## APPENDIX I - FREQUENCY STABILITY



Test Mode	LTE Band 26_CH26740_1.4M
-----------	--------------------------

**Temperature vs. Frequency Stability**

Temperature(°C)	Frequency Error (Hz)	Frequency Error (ppm)	Limit(ppm)
0	3.43	0.004188034	±2.5
5	-1.91	-0.002332112	
15	2.72	0.003321123	
25	3.01	0.003675214	
35	-3.60	-0.004395604	
Max. Deviation (ppm)	-3.6	-0.004395604	

**Voltage vs. Frequency Stability**

Voltage(Volts)	Frequency Error (Hz)	Frequency Error (ppm)	Limit(ppm)
4.4	-3.04	-0.003711844	±2.5
3.85	-4.06	-0.004957265	
3.6	-3.01	-0.003675214	
Max. Deviation (ppm)	-4.06	-0.004957265	

Test Mode	LTE Band 26_CH26740_3M
-----------	------------------------

**Temperature vs. Frequency Stability**

Temperature(°C)	Frequency Error (Hz)	Frequency Error (ppm)	Limit(ppm)
0	-4.88	-0.005958486	±2.5
5	3.06	0.003736264	
15	2.29	0.002796093	
25	2.88	0.003516484	
35	3.62	0.004420024	
Max. Deviation (ppm)	-4.88	-0.005958486	

**Voltage vs. Frequency Stability**

Voltage(Volts)	Frequency Error (Hz)	Frequency Error (ppm)	Limit(ppm)
4.4	-4.86	-0.005934066	±2.5
3.85	1.76	0.002148962	
3.6	2.25	0.002747253	
Max. Deviation (ppm)	-4.86	-0.005934066	

Test Mode	LTE Band 26_CH26740_5M
-----------	------------------------

**Temperature vs. Frequency Stability**

Temperature(°C)	Frequency Error (Hz)	Frequency Error (ppm)	Limit(ppm)
0	-1.09	-0.001330891	±2.5
5	-3.27	-0.003992674	
15	-1.84	-0.002246642	
25	-1.85	-0.002258852	
35	3.57	0.004358974	
Max. Deviation (ppm)	3.57	0.004358974	

**Voltage vs. Frequency Stability**

Voltage(Volts)	Frequency Error (Hz)	Frequency Error (ppm)	Limit(ppm)
4.4	1.05	0.001282051	±2.5
3.85	-2.52	-0.003076923	
3.6	1.05	0.001282051	
Max. Deviation (ppm)	-2.52	-0.003076923	

Test Mode	LTE Band 26_CH26740_10M
-----------	-------------------------

**Temperature vs. Frequency Stability**

Temperature(°C)	Frequency Error (Hz)	Frequency Error (ppm)	Limit(ppm)
0	1.08	0.001318681	±2.5
5	2.88	0.003516484	
15	1.11	0.001355311	
25	1.44	0.001758242	
35	2.25	0.002747253	
Max. Deviation (ppm)	2.88	0.003516484	

**Voltage vs. Frequency Stability**

Voltage(Volts)	Frequency Error (Hz)	Frequency Error (ppm)	Limit(ppm)
4.4	1.72	0.002100122	±2.5
3.85	-1.23	-0.001501832	
3.6	-1.27	-0.001550672	
Max. Deviation (ppm)	1.72	0.002100122	

End of Test Report