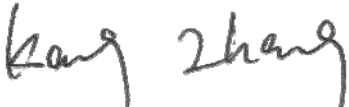
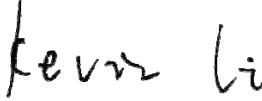

# FCC EMC Test Report

**Project No.** : 2008C120  
**Equipment** : Mobile Phone  
**Brand Name** : OPPO  
**Test Model** : CPH2185  
**Series Model** : N/A  
**Applicant** : Guangdong OPPO Mobile Telecommunications Corp., Ltd.  
**Address** : NO. 18 HaiBin Road, Wusha Village, Chang An Town, DongGuan City, Guangdong, China  
**Manufacturer** : Guangdong OPPO Mobile Telecommunications Corp., Ltd.  
**Address** : NO. 18 HaiBin Road, Wusha Village, Chang An Town, DongGuan City, Guangdong, China  
**Factory** : Guangdong OPPO Mobile Telecommunications Corp., Ltd.  
**Address** : NO. 18 HaiBin Road, Wusha Village, Chang An Town, DongGuan City, Guangdong, China  
**Date of Receipt** : Aug. 27, 2020  
**Date of Test** : Sep. 01, 2020 ~ Sep. 17, 2020  
**Issued Date** : Sep. 25, 2020  
**Report Version** : R01  
**Test Sample** : Engineering Sample No.: DG2020083149  
**Standard(s)** : FCC CFR Title 47, Part 15, Subpart B

The above equipment has been tested and found compliance with the requirement of the relative standards by BTL Inc.

  
Prepared by : Kang Zhang

  
Approved by : Kevin Li



Certificate #5123.02

Add: No.3, Jinshagang 1st Road, Shixia, Dalang Town, Dongguan, Guangdong, China.

Tel: +86-769-8318-3000

Web: [www.newbtl.com](http://www.newbtl.com)

**Declaration**

**BTL** represents to the client that testing is done in accordance with standard procedures as applicable and that test instruments used has been calibrated with standards traceable to international standard(s) and/or national standard(s).

**BTL's** reports apply only to the specific samples tested under conditions. It is manufacture's responsibility to ensure that additional production units of this model are manufactured with the identical electrical and mechanical components. **BTL** shall have no liability for any declarations, inferences or generalizations drawn by the client or others from **BTL** issued reports.

The report must not be used by the client to claim product certification, approval, or endorsement by NIST, A2LA, or any agency of the U.S. Government.

This report is the confidential property of the client. As a mutual protection to the clients, the public and ourselves, the test report shall not be reproduced, except in full, without our written approval.

**BTL's** laboratory quality assurance procedures are in compliance with the **ISO/IEC 17025** requirements, and accredited by the conformity assessment authorities listed in this test report.

**BTL** is not responsible for the sampling stage, so the results only apply to the sample as received.

The information, data and test plan are provided by manufacturer which may affect the validity of results, so it is manufacturer's responsibility to ensure that the apparatus meets the essential requirements of applied standards and in all the possible configurations as representative of its intended use.

**Limitation**

For the use of the authority's logo is limited unless the Test Standard(s)/Scope(s)/Item(s) mentioned in this test report is (are) included in the conformity assessment authorities acceptance respective.

Please note that the measurement uncertainty is provided for informational purpose only and are not use in determining the Pass/Fail results.

<b>Table of Contents</b>	<b>Page</b>
<b>REPORT ISSUED HISTORY</b>	<b>4</b>
<b>1 . SUMMARY OF TEST RESULTS</b>	<b>5</b>
1.1 TEST FACILITY	6
1.2 MEASUREMENT UNCERTAINTY	6
1.3 TEST ENVIRONMENT CONDITIONS	6
<b>2 . GENERAL INFORMATION</b>	<b>7</b>
2.1 GENERAL DESCRIPTION OF EUT	7
2.2 DESCRIPTION OF TEST MODES	8
2.3 EUT OPERATING CONDITIONS	10
2.4 BLOCK DIAGRAM SHOWING THE CONFIGURATION OF SYSTEM TESTED	10
2.5 DESCRIPTION OF SUPPORT UNITS	12
<b>3 . EMC EMISSION TEST</b>	<b>13</b>
3.1 AC POWER LINE CONDUCTED EMISSIONS TEST	13
3.1.1 LIMIT	13
3.1.2 MEASUREMENT INSTRUMENTS LIST	13
3.1.3 TEST PROCEDURE	14
3.1.4 DEVIATION FROM TEST STANDARD	14
3.1.5 TEST SETUP	14
3.1.6 TEST RESULTS	14
3.2 RADIATED EMISSIONS 30 MHZ TO 1 GHZ	17
3.2.1 LIMIT	17
3.2.2 MEASUREMENT INSTRUMENTS LIST	17
3.2.3 TEST PROCEDURE	18
3.2.4 DEVIATION FROM TEST STANDARD	18
3.2.5 TEST SETUP	18
3.2.6 TEST RESULTS	18
3.3 RADIATED EMISSIONS ABOVE 1 GHZ	21
3.3.1 LIMIT	21
3.3.2 MEASUREMENT INSTRUMENTS LIST	22
3.3.3 TEST PROCEDURE	22
3.3.4 DEVIATION FROM TEST STANDARD	22
3.3.5 TEST SETUP	23
3.3.6 TEST RESULTS	24
<b>4 . EUT TEST PHOTO</b>	<b>33</b>

**REPORT ISSUED HISTORY**

Report Version	Description	Issued Date
R00	Original Issue.	Sep. 23, 2020
R01	Updated the software version	Sep. 25, 2020

**1. SUMMARY OF TEST RESULTS**

<b>Emission</b>		
<b>Ref Standard(s)</b>	<b>Test Item</b>	<b>Result</b>
FCC CFR Title 47,Part 15,Subpart B ANSI C63.4-2014	AC Power Line Conducted Emissions	PASS
	Radiated Emissions 30 MHz to 1 GHz	PASS
	Radiated Emissions Above 1 GHz	PASS

### 1.1 TEST FACILITY

The test facilities used to collect the test data in this report at the location of No.3, Jinshagang 1st Road, Shixia, Dalang Town, Dongguan, Guangdong, China.

BTL's Test Firm Registration Number for FCC: 357015

BTL's Designation Number for FCC: CN1240

### 1.2 MEASUREMENT UNCERTAINTY

ISO/IEC 17025 requires that an estimate of the measurement uncertainties associated with the emissions test results be included in the report. The measurement uncertainties given below are based on a 95% confidence level (based on a coverage factor (k=2))

The BTL measurement uncertainty as below table:

#### A. AC power line conducted emissions test:

Test Site	Method	Measurement Frequency Range	U,(dB)
DG-C02	CISPR	150kHz ~ 30MHz	2.68

#### B. Radiated emissions test:

Test Site	Method	Measurement Frequency Range	Ant. H / V	U,(dB)
DG-CB02 (3m)	CISPR	30MHz ~ 200MHz	V	4.80
		30MHz ~ 200MHz	H	3.84
		200MHz ~ 1,000MHz	V	4.06
		200MHz ~ 1,000MHz	H	3.56

Test Site	Method	Measurement Frequency Range	U,(dB)
DG-CB02 (3m)	CISPR	1GHz ~ 6GHz	4.06
		6GHz ~ 18GHz	5.20

Test Site	Method	Measurement Frequency Range	U,(dB)
DG-CB02 (1m)	CISPR	18 ~ 26.5 GHz	3.62
		26.5 ~ 40 GHz	4.00

Note: Unless specifically mentioned, the uncertainty of measurement has not been taken into account to declare the compliance or non-compliance to the specification.

### 1.3 TEST ENVIRONMENT CONDITIONS

Test Item	Temperature	Humidity	Tested By
AC Power Line Conducted Emissions	25°C	53%	Gerry Zhang
Radiated emissions 30 MHz to 1 GHz	24°C	60%	Luca Jiang
Radiated emissions above 1 GHz	24°C	60%	Wade Liang

## 2. GENERAL INFORMATION

### 2.1 GENERAL DESCRIPTION OF EUT

Equipment	Mobile Phone
Brand Name	OPPO
Test Model	CPH2185
Series Model	N/A
Model Difference(s)	N/A
Hardware Version	11
Software Version	Color OS V7.2
Power Source	<ol style="list-style-type: none"> <li>1. DC Voltage supplied from AC/DC adapter.            1# Model: OP52YAUH            2# Model: OP52JAUH            3# Model: OP52KAUH            4# Model: OP52JBUH</li> <li>2. Supplied from Li-ion Polymer battery.            Model: BLP817</li> <li>3. Supplied from USB port.</li> </ol>
Power Rating	<ol style="list-style-type: none"> <li>1. I/P:100-240V~ 50/60Hz 0.4A    O/P:5V --- 2A</li> <li>2. 3.85Vdc, 4100mAh/15.78Wh</li> <li>3. DC 5V</li> </ol>
Connecting I/O Port(s)	<ol style="list-style-type: none"> <li>1* Earphone port</li> <li>1* Type-C port</li> </ol>
Classification of EUT	Class B
Highest Internal Frequency(Fx)	5850 MHz

Note:

1. For a more detailed features description, please refer to the manufacturer's specifications or the user's manual.

## 2.2 DESCRIPTION OF TEST MODES

To investigate the maximum EMI emission characteristics generated from EUT, the test system was pre-scanning tested based on the consideration of following EUT operation mode or test configuration mode which possibly have effect on EMI emission level. Each of these EUT operation mode(s) or test configuration mode(s) mentioned above was evaluated respectively.

Pretest Mode	Description
Mode 1	Adapter+Idle+Playing+Speaker
Mode 2	Adapter+Idle+Playing+earphone
Mode 3	Adapter+Idle+2.4G WIFI+BT+GPS+Camera on(Front)
Mode 4	Adapter+Idle+2.4G WIFI+BT+GPS+Camera on(Rear)
Mode 5	Adapter+Idle+5G WIFI+BT+GPS+Camera on(Front)
Mode 6	Adapter+Idle+5.8G WIFI+BT+GPS+Camera on(Front)
Mode 7	Adapter+Traffic(GSM)(GSM850.1900)
Mode 8	Adapter+Traffic(WCDMA)(BAND2.4.5)
Mode 9	Adapter+Traffic(LTE)( Band2/4/5/7/12/17/26/38/41/66)
Mode 10	FM 88MHz+earphone
Mode 11	FM 98MHz+earphone
Mode 12	FM 108MHz+earphone
Mode 13	USB Copy + Idle

AC Power Line Conducted Emissions test	
Final Test Mode	Description
Mode 5	Adapter+Idle+5G WIFI+BT+GPS+Camera on(Front)

Radiated Emissions 30 MHz to 1 GHz test	
Final Test Mode	Description
Mode 5	Adapter+Idle+5G WIFI+BT+GPS+Camera on(Front)

Radiated emissions above 1 GHz test	
Final Test Mode	Description
Mode 5	Adapter+Idle+5G WIFI+BT+GPS+Camera on(Front)



Item	Model	Factory	config1	config2	config3	Config4
Adapter	OP52YAUH	/	V			
	OP52JAUH	/		V		
	OP52KAUH	/			V	
	OP52JBUH	/				V
USB Cable	DL122	/	V	V	V	V
Battery	BLP817	Sunwoda(XGxxxxxxxx)	V			
		Sunwoda(XWxxxxxxxx)		V		
		TWS			V	
		NVT				V
Earphone	/	/	V	V	V	V

Evaluation description:

1. Mode 1: Tested config1-4. Config 1 is the worst case and tested Mode 2-13. Config1 with Mode 5 is the worst case and recorded in this report.

Note:

1. The frequency of BT&2.4G WIFI exemption is 2400-2483.5MHz.
2. The frequency of 5G WIFI exemption is 5150-5250MHz, 5250-5350MHz, 5470-5725MHz, 5725-5850MHz.

### 2.3 EUT OPERATING CONDITIONS

The EUT exercise program used during radiated and/or conducted emission measurement was designed to exercise the various system components in a manner similar to a typical use. The standard test signals and output signal as following:

Mode 1-12:

1. EUT connected to Earphone via Earphone cable.
2. EUT connected to Adapter via USB cable.
3. EUT connected to Wireless Router via WIFI function.
4. EUT connected to BT Earphone via BT function.
5. EUT connected to Wireless Communication Test SET via GSM/WCDMA function.
6. EUT connected to Wideband Radio Communication Tester via LTE function.
7. EUT connected to FM STEREO FM-AM signal generator via FM function.
8. EUT connected to Signal Generator via GPS function.

Mode 13:

1. EUT connected to PC via USB cable.
2. Keyboard and mouse connected to PC via USB cable.
3. PC connected to monitor via D-SUB cable.
4. PC connected to printer via parallel cable.
5. PC connected to modem via RS232 cable.

### 2.4 BLOCK DIAGRAM SHOWING THE CONFIGURATION OF SYSTEM TESTED

Mode 1-12

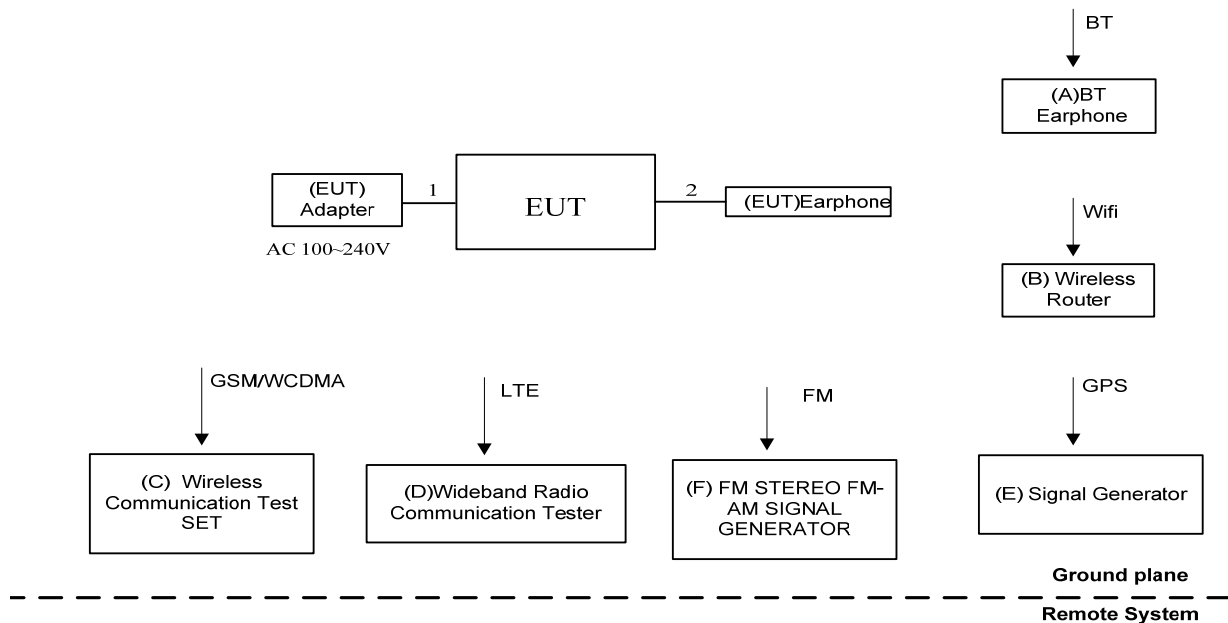

### Mode 13

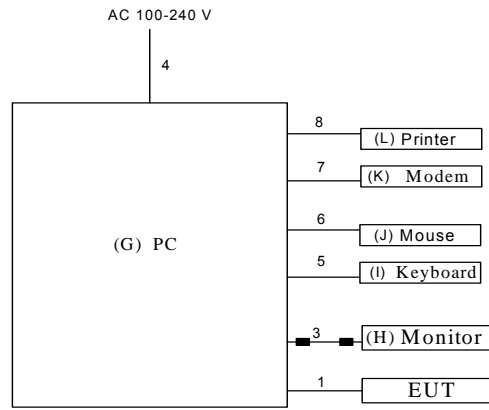

■ Ferrite core

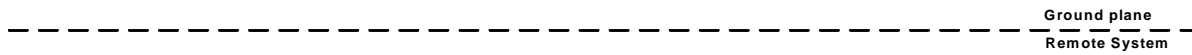

## 2.5 DESCRIPTION OF SUPPORT UNITS

The EUT has been tested as an independent unit together with other necessary accessories or support units. The following support units or accessories were used to form a representative test configuration during the tests.

Item	Equipment	Mfr/Brand	Model/Type No.	Series No.
A	BT Earphone	MICROKIA	M9	N/A
B	Wireless Router	ASUS	RT-AC66U	E8ICGG000138
C	Wireless Communication Test SET	Agilent	(8960 Series) E5515C	MY48364183
D	Wideband Radio Communication Tester	RS	CMW500	122125
E	Signal Generator	Agilent	E4438C	MY49071316
F	FM STEREO FM-AM SIGNAL GENERATOR	KENWOOD	SG-5110	HR1010099
G	PC	Dell	DCSM	G7K832X
H	Monitor	Dell	U2410	824266A2D010R
I	Keyboard	Dell	L100	CNORH6596589071T08NE
J	Mouse	Dell	MO56UOA	FQJ000BS
K	Modem	ACEEX	DM-1414V	0603002131
L	Printer	SII	DPU-414	3018507 B

Item	Cable Type	Shielded Type	Ferrite Core	Length
1	USB Cable	YES	NO	1m
2	Earphone Cable	NO	NO	1m
3	D-SUB Cable	YES	YES	1.8m
4	AC Cable	NO	NO	1.8m
5	USB Cable	YES	NO	1.8m
6	USB Cable	YES	NO	1.8m
7	RS232 Cable	YES	NO	1.2m
8	Parallel Cable	YES	NO	1.2m

### 3. EMC EMISSION TEST

#### 3.1 AC POWER LINE CONDUCTED EMISSIONS TEST

##### 3.1.1 LIMIT

Frequency of Emission (MHz)	Class B (dBuV)	
	Quasi-peak	Average
0.15 - 0.5	66 - 56 *	56 - 46 *
0.5 - 5.0	56.00	46.00
5.0 - 30.0	60.00	50.00

Note:

- (1) The tighter limit applies at the band edges.
- (2) The limit of " \* " marked band means the limitation decreases linearly with the logarithm of the frequency in the range.
- (3) The test result calculated as following:  
 Measurement Value = Reading Level + Correct Factor  
 Correct Factor = Insertion Loss + Cable Loss + Attenuator Factor(if use)  
 Margin Level = Measurement Value - Limit Value

##### 3.1.2 MEASUREMENT INSTRUMENTS LIST

Item	Kind of Equipment	Manufacturer	Type No.	Serial No.	Calibrated until
1	EMI Test Receiver	R&S	ESCI	100382	Feb. 28, 2021
2	LISN	EMCO	3816/2	52765	Mar. 01, 2021
3	TWO-LINE V-NETWORK	R&S	ENV216	101447	Feb. 28, 2021
4	50Ω Terminator	SHX	TF5-3	15041305	Mar. 01, 2021
5	Measurement Software	Farad	EZ-EMC Ver.NB-03A1-01	N/A	N/A
6	Cable	N/A	RG223	12m	Mar. 10, 2021

Remark: "N/A" denotes no model name, serial no. or calibration specified.

All calibration period of equipment list is one year.

### 3.1.3 TEST PROCEDURE

- a. The EUT was placed 0.8 meters from the horizontal ground plane with EUT being connected to the power mains through a line impedance stabilization network (LISN). All other support equipment powered from additional LISN(s). The LISN provide 50 Ohm/ 50uH of coupling impedance for the measuring instrument.
- b. Interconnecting cables that hang closer than 40 cm to the ground plane shall be folded back and forth in the center forming a bundle 30 to 40 cm long.
- c. I/O cables that are not connected to a peripheral shall be bundled in the center. The end of the cable may be terminated, if required, using the correct terminating impedance. The overall length shall not exceed 1 m.
- d. LISN at least 80 cm from nearest part of EUT chassis.
- e. For the actual test configuration, please refer to the related Item –EUT Test Photos.
- f. Measuring frequency range from 150KHz to 30MHz.

### 3.1.4 DEVIATION FROM TEST STANDARD

No deviation

### 3.1.5 TEST SETUP

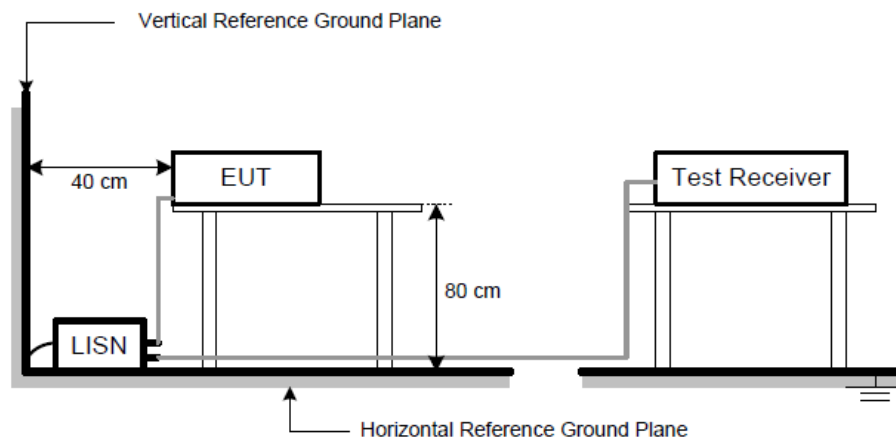

### 3.1.6 TEST RESULTS

Remark:

- (1) Reading in which marked as QP means measurements by using are Quasi-Peak Mode with Detector BW=9 kHz; SPA setting in RBW=10 kHz, VBW =10 kHz, Swp. Time = 0.3 sec./MHz. Reading in which marked as AV means measurements by using are Average Mode with instrument setting in RBW=10 kHz, VBW=10 kHz, Swp. Time =0.3 sec./MHz.
- (2) All readings are QP Mode value unless otherwise stated AVG in column of 『Note』 . If the QP Mode Measured value compliance with the QP Limits and lower than AVG Limits, the EUT shall be deemed to meet both QP & AVG Limits and then only QP Mode was measured, but AVG Mode didn't perform. In this case, a “ \* ” marked in AVG Mode column of Interference Voltage Measured.

Test Voltage	AC 120V/60Hz	Phase	Line
Test Mode	Mode 5(Config1)		

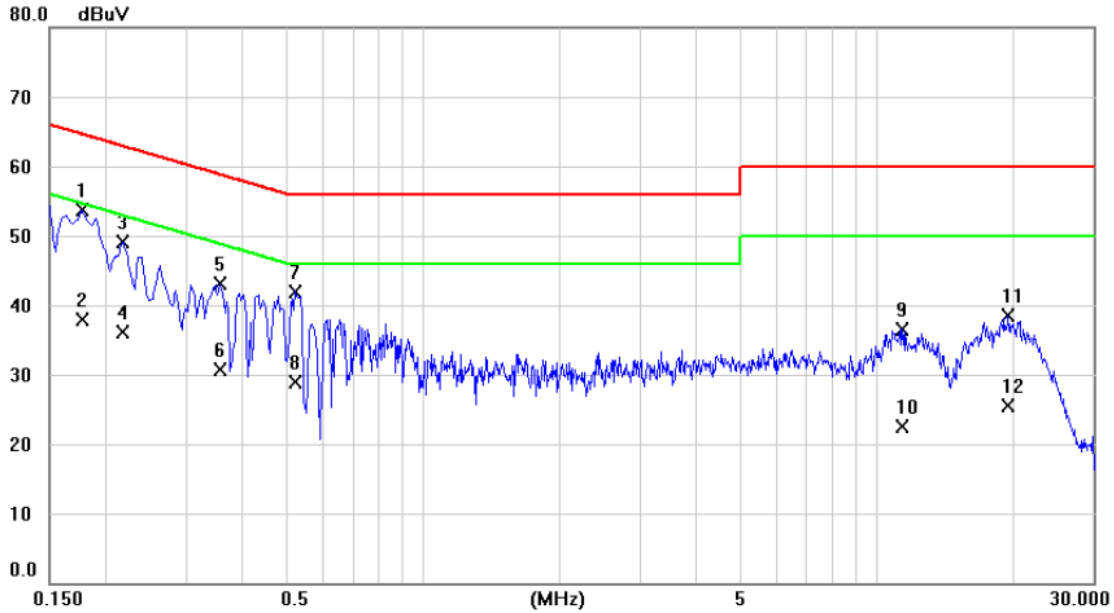

No.	Mk.	Freq. MHz	Reading Level dBuV	Correct Factor dB	Measure- ment dBuV	Limit dBuV	Margin dB	Detector	Comment
1	*	0.1770	43.84	9.84	53.68	64.63	-10.95	QP	
2		0.1770	28.10	9.84	37.94	54.63	-16.69	AVG	
3		0.2175	39.24	9.90	49.14	62.91	-13.77	QP	
4		0.2175	26.30	9.90	36.20	52.91	-16.71	AVG	
5		0.3570	33.23	9.91	43.14	58.80	-15.66	QP	
6		0.3570	20.80	9.91	30.71	48.80	-18.09	AVG	
7		0.5235	32.05	9.95	42.00	56.00	-14.00	QP	
8		0.5235	19.00	9.95	28.95	46.00	-17.05	AVG	
9		11.3910	25.78	10.76	36.54	60.00	-23.46	QP	
10		11.3910	11.80	10.76	22.56	50.00	-27.44	AVG	
11		19.4775	27.70	10.90	38.60	60.00	-21.40	QP	
12		19.4775	14.70	10.90	25.60	50.00	-24.40	AVG	

Test Voltage	AC 120V/60Hz	Phase	Neutral
Test Mode	Mode 5(Config1)		

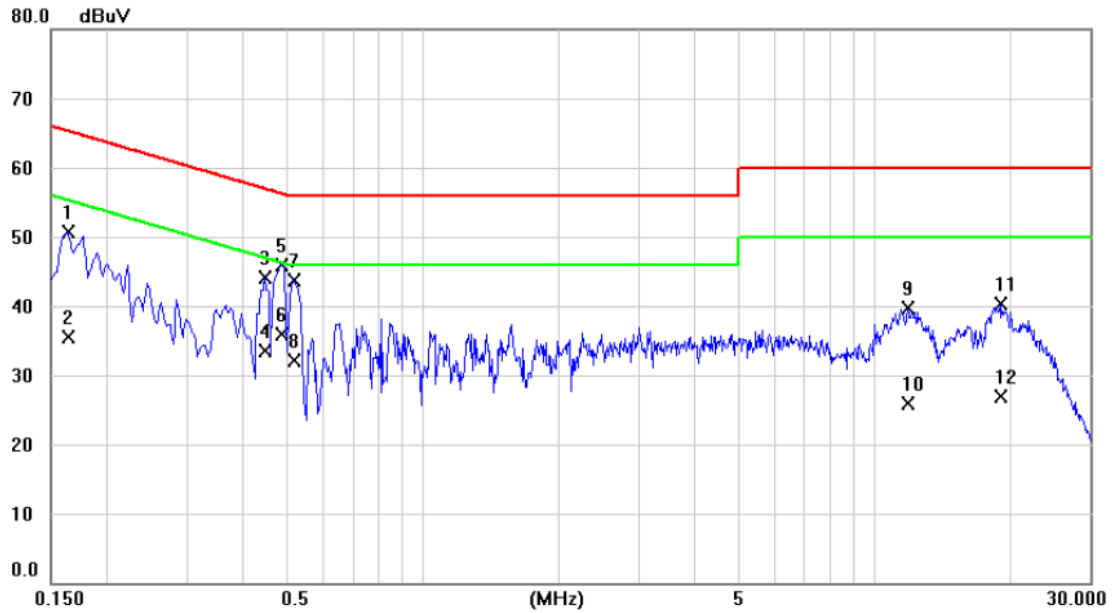

No.	Mk.	Freq. MHz	Reading Level dBuV	Correct Factor dB	Measure- ment dBuV	Limit dBuV	Margin dB	Detector	Comment
1		0.1635	40.91	9.85	50.76	65.28	-14.52	QP	
2		0.1635	25.60	9.85	35.45	55.28	-19.83	AVG	
3		0.4470	34.07	10.11	44.18	56.93	-12.75	QP	
4		0.4470	23.30	10.11	33.41	46.93	-13.52	AVG	
5	*	0.4875	35.75	10.13	45.88	56.21	-10.33	QP	
6		0.4875	25.70	10.13	35.83	46.21	-10.38	AVG	
7		0.5190	33.55	10.15	43.70	56.00	-12.30	QP	
8		0.5190	22.00	10.15	32.15	46.00	-13.85	AVG	
9		11.8635	28.62	11.08	39.70	60.00	-20.30	QP	
10		11.8635	14.80	11.08	25.88	50.00	-24.12	AVG	
11		19.0185	29.18	11.19	40.37	60.00	-19.63	QP	
12		19.0185	15.70	11.19	26.89	50.00	-23.11	AVG	



### 3.2 RADIATED EMISSIONS 30 MHZ TO 1 GHZ

#### 3.2.1 LIMIT

Frequency (MHz)	Class B (at 3m)	
	(uV/m) Field strength	(dBuV/m) Field strength
30 - 88	100	40
88 - 216	150	43.5
216 - 960	200	46
Above 960	500	54

**NOTE:**

- (1) The tighter limit applies at the band edges.
- (2) Emission level (dBuV/m) =  $20\log$  Emission level (uV/m).  
3m Emission level = 10m Emission level +  $20\log(10\text{m}/3\text{m})$ .
- (3) The test result calculated as following:  
 Measurement Value = Reading Level + Correct Factor  
 Correct Factor = Antenna Factor + Cable Loss - Amplifier Gain(if use)  
 Margin Level = Measurement Value - Limit Value

#### 3.2.2 MEASUREMENT INSTRUMENTS LIST

Item	Kind of Equipment	Manufacturer	Type No.	Serial No.	Calibrated until
1	Amplifier	HP	8447D	1937A02847	Feb. 28, 2021
2	Cable	emci	LMR-400(30MHz-1GHz) (10m+2.5m)	N/A	Jun. 03, 2021
3	Controller	MF	MF-7802BS	N/A	N/A
4	Measurement Software	Farad	EZ-EMC Ver.NB-03A1-01	N/A	N/A
5	EMI Test Receiver	Keysight	N9038A	MY56400060	Feb. 28, 2021
6	Trilog-Broadband Antenna	Schwarzbeck	VULB9168	9168-806	Aug. 27, 2020

Remark: "N/A" denotes no model name, no serial no. or no calibration specified.

All calibration period of equipment list is one year.

### 3.2.3 TEST PROCEDURE

- The measuring distance of 3 m shall be used for measurements. The EUT was placed on the top of a rotating table 0.8 meter above the ground at a 3 meter semi-anechoic chamber. The table was rotated 360 degrees to determine the position of the highest radiation.
- The height of the equipment or of the substitution antenna shall be 0.8 m, the height of the test antenna shall vary between 1 m to 4 m. Both horizontal and vertical polarizations of the antenna are set to make the measurement.
- For each suspected emission, the EUT was arranged to its worst case and then the antenna was tuned to heights find the maximum reading (used Bore sight function).
- The initial step in collecting radiated emission data is a receiver peak detector mode pre-scanning the measurement frequency range. Significant peaks are then marked and then Quasi Peak detector mode re-measured.
- All readings are Peak unless otherwise stated QP in column of Note. Peak denotes that the Peak reading compliance with the QP Limits and then QP Mode measurement didn't perform.
- For the actual test configuration, please refer to the related Item - Block Diagram of system tested.

### 3.2.4 DEVIATION FROM TEST STANDARD

No deviation

### 3.2.5 TEST SETUP

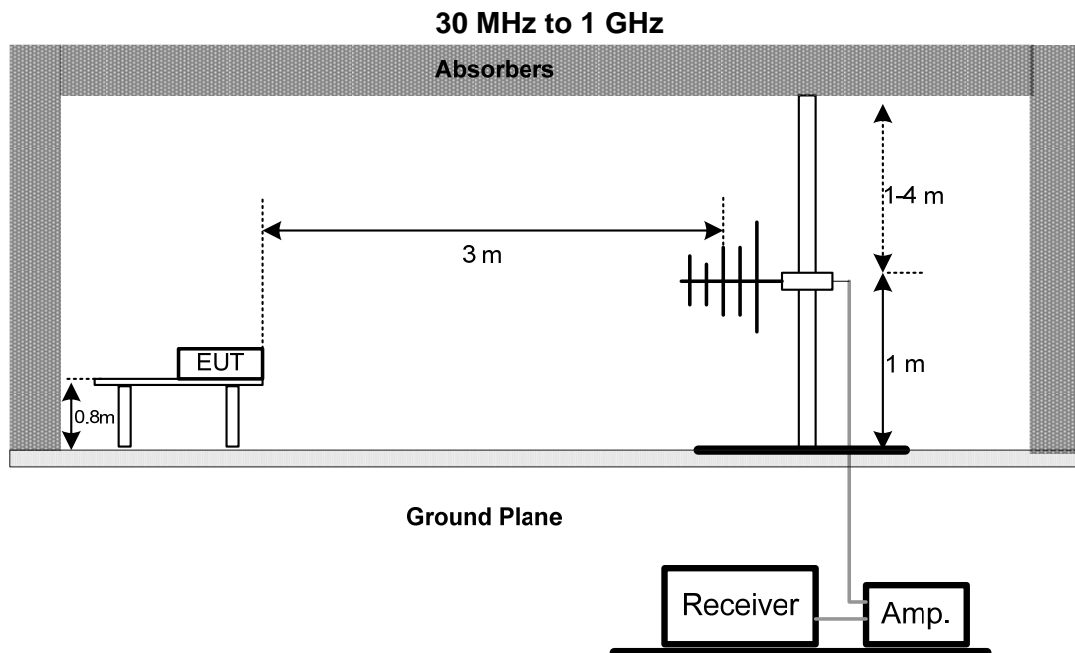

### 3.2.6 TEST RESULTS

Remark:

- (1) Measuring frequency range from 30 MHz to 1000 MHz
- (2) If the peak scan value lower limit more than 20 dB, then this signal data does not show in table.

Test Voltage	AC 120V/60Hz	Polarization	Vertical
Test Mode	Mode 5(Config1)		

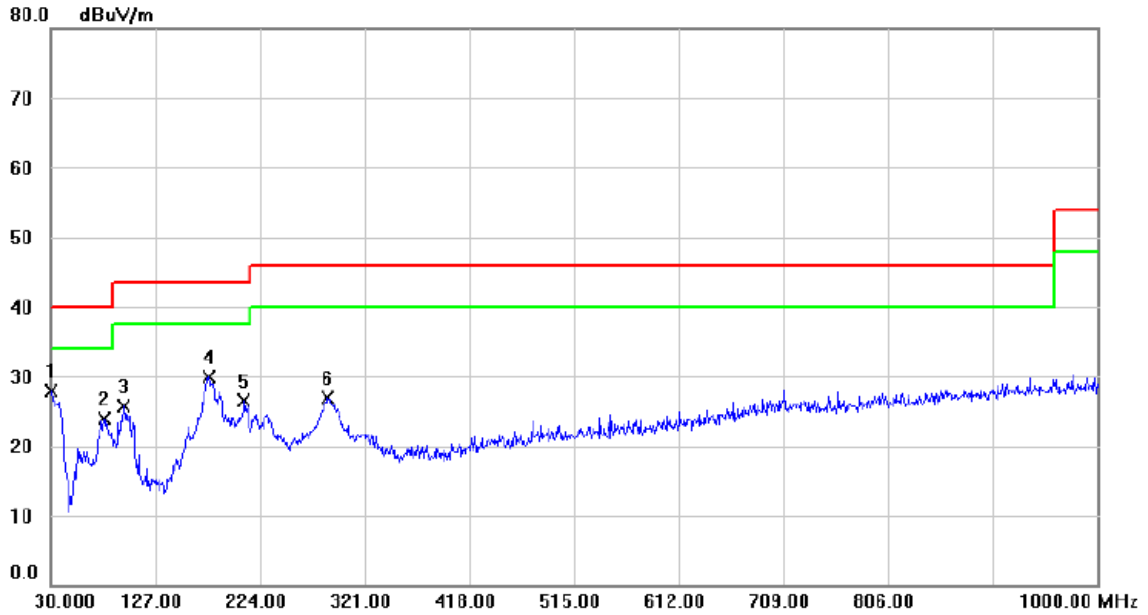

No.	Mk.	Freq. MHz	Reading Level dBuV	Correct Factor dB	Measure- ment dBuV/m	Limit dBuV/m	Margin dB	Detector	Comment
1	*	30.9700	33.04	-5.10	27.94	40.00	-12.06	QP	
2		79.4700	44.19	-20.36	23.83	40.00	-16.17	QP	
3		97.9000	44.20	-18.54	25.66	43.50	-17.84	QP	
4		176.4700	46.22	-16.32	29.90	43.50	-13.60	QP	
5		209.4500	41.60	-15.04	26.56	43.50	-16.94	QP	
6		287.0500	38.79	-11.96	26.83	46.00	-19.17	QP	

Test Voltage	AC 120V/60Hz	Polarization	Horizontal
Test Mode	Mode 5(Config1)		

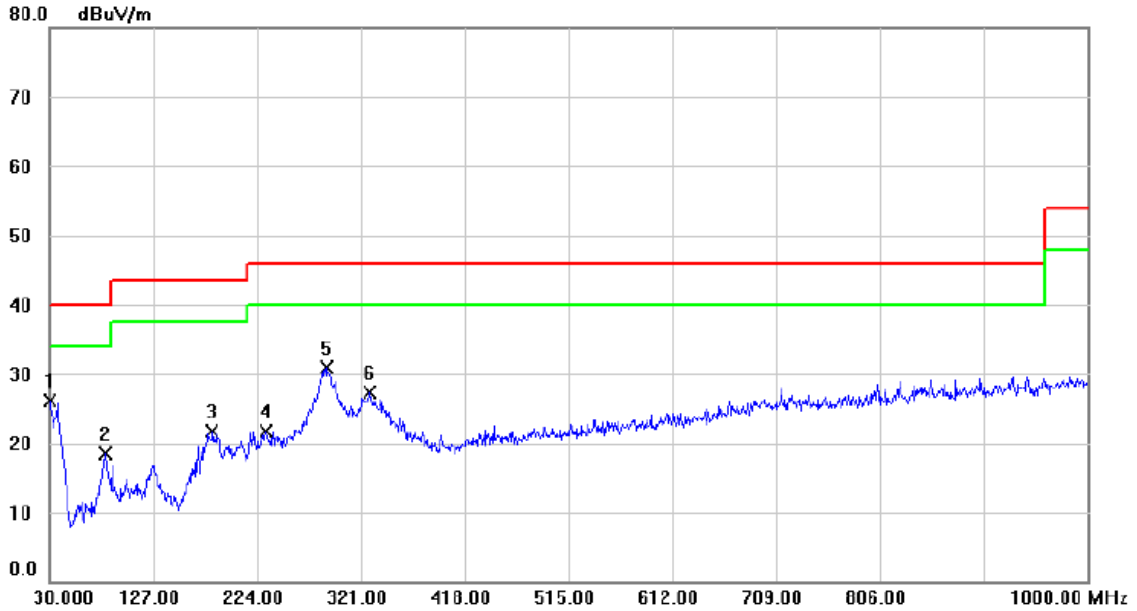

No.	Mk.	Freq. MHz	Reading Level dBuV	Correct Factor dB	Measure- ment dBuV/m	Limit dBuV/m	Margin dB	Detector	Comment
1	*	30.0000	30.27	-4.19	26.08	40.00	-13.92	QP	
2		82.3800	38.99	-20.45	18.54	40.00	-21.46	QP	
3		182.2900	37.71	-16.03	21.68	43.50	-21.82	QP	
4		231.7600	35.68	-13.91	21.77	46.00	-24.23	QP	
5		289.9600	42.73	-11.91	30.82	46.00	-15.18	QP	
6		329.7300	37.56	-10.33	27.23	46.00	-18.77	QP	

### 3.3 RADIATED EMISSIONS ABOVE 1 GHZ

#### 3.3.1 LIMIT

Frequency (MHz)	Class B	
	(dBuV/m) (at 3m)	
	Peak	Average
Above 1000	74	54

Frequency (MHz)	Class B	
	(dBuV/m) (at 1m)	
	Peak	Average
Above 18000	83.5	63.5

#### FREQUENCY RANGE OF RADIATED MEASUREMENT (FOR UNINTENTIONAL RADIATORS)

Highest frequency generated or Upper frequency of measurement used in the device or on which the device operates or tunes (MHz)	Range (MHz)
Below 1.705	30
1.705 - 108	1000
108 - 500	2000
500 - 1000	5000
Above 1000	5 <sup>th</sup> harmonic of the highest frequency or 40 GHz, whichever is lower

**NOTE:**

- (1) The tighter limit applies at the band edges.
- (2) Emission level (dBuV/m) = 20log Emission level (uV/m).  
3m Emission level = 10m Emission level + 20log(10m/3m).
- (3) The test result calculated as following:  
Measurement Value = Reading Level + Correct Factor  
Correct Factor = Antenna Factor + Cable Loss - Amplifier Gain(if use)  
Margin Level = Measurement Value - Limit Value

### 3.3.2 MEASUREMENT INSTRUMENTS LIST

Item	Kind of Equipment	Manufacturer	Type No.	Serial No.	Calibrated until
1	Double Ridged Horn Antenna	ARA	DRG-118A	16554	Apr. 17, 2021
2	Amplifier	Agilent	8449B	3008A02334	Mar. 01, 2021
3	Cable	mitron	RWLP50-4.0A-KJ-SMSM-12M	N/A	Nov. 25, 2020
4	Controller	MF	MF-7802BS	N/A	N/A
5	Measurement Software	Farad	EZ-EMC Ver.NB-03A1-01	N/A	N/A
6	EMI Test Receiver	Keysight	N9038A	MY56400060	Feb. 28, 2021
7	Band Reject Filter	Wairwright Instruments Gmbh	WRCG 2400/2483-2375/2505-50/ 10SS	16	Feb. 28, 2021
8	Band Reject Filter	Micro-Tronics	BRC50705-01	10	Feb. 28, 2021
9	Band Reject Filter	Micro-Tronics	BRC50704-01	8	Feb. 28, 2021
10	Band Reject Filter	Micro-Tronics	BRC50703-01	7	Feb. 28, 2021

Remark: "N/A" denotes no model name, no serial no. or no calibration specified.

All calibration period of equipment list is one year.

### 3.3.3 TEST PROCEDURE

- a. The measuring distance of 3 m shall be used for measurements. The EUT was placed on the top of a rotating table 0.8 meter above the ground at a 3 meter semi-anechoic chamber. The table was rotated 360 degrees to determine the position of the highest radiation.  
 Note:  
 For measurement of frequency 1GHz -18GHz, the EUT was set 3 meters away from the receiver antenna. For 18G – 40GHz, the EUT was set 1 meter.  
 Emission level (dBuV/m)=20log Emission level (uV/m).  
 The limits above 18GHz shall be extrapolated to the specified distance using an extrapolation factor of 20dB/decade from 3m to 1m  
 Distance extrapolation factor = 20 log (3m/1m) dB ;  
 Limit line = specific limits (dBuV) + 9.5 dB.
- b. The height of the equipment or of the substitution antenna shall be 0.8 m, the height of the test antenna shall vary between 1 m to 4 m. Both horizontal and vertical polarizations of the antenna are set to make the measurement.
- c. For each suspected emission, the EUT was arranged to its worst case and then the antenna was tuned to heights find the maximum reading (used Bore sight function).
- d. The initial step in collecting radiated emission data is a receiver peak detector mode pre-scanning the measurement frequency range. Significant peaks are then marked and then Quasi Peak detector mode re-measured.
- e. The receiver system was set to peak and average detect function and specified bandwidth with maximum hold mode when the test frequency is above 1 GHz.
- f. All readings are Peak Mode value unless otherwise stated AVG in column of Note. If the Peak Mode Measured value compliance with the Peak Limits and lower than AVG Limits, the EUT shall be deemed to meet both Peak & AVG Limits and then only Peak Mode was measured, but AVG Mode didn't perform.
- g. For the actual test configuration, please refer to the related Item - Block Diagram of system tested.

### 3.3.4 DEVIATION FROM TEST STANDARD

No deviation

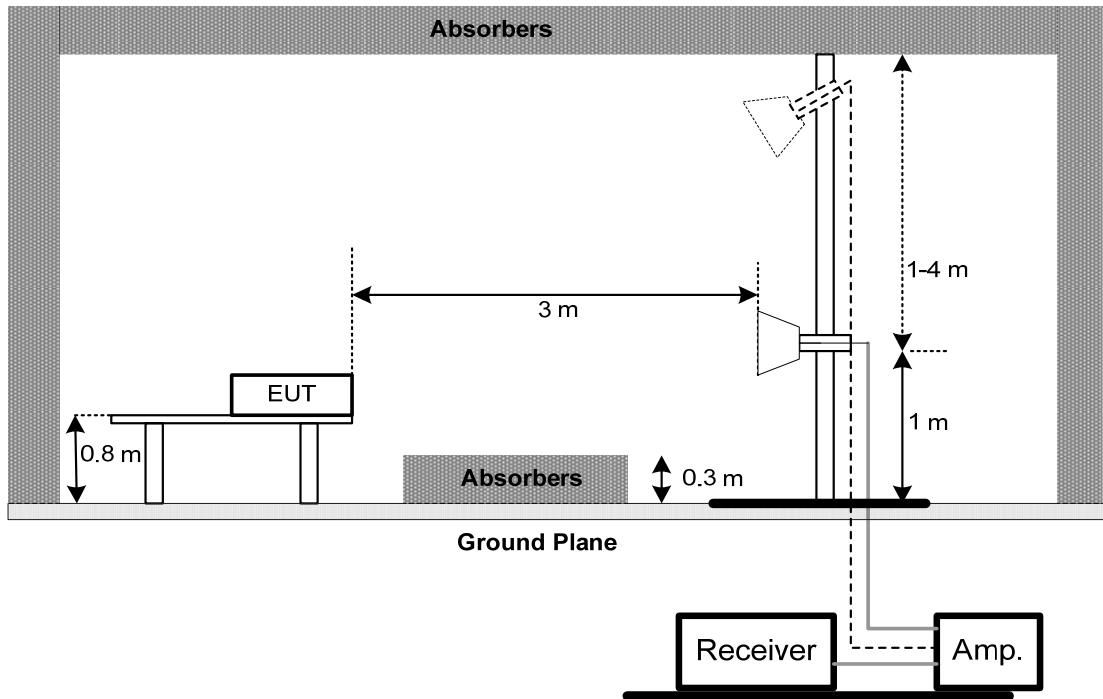
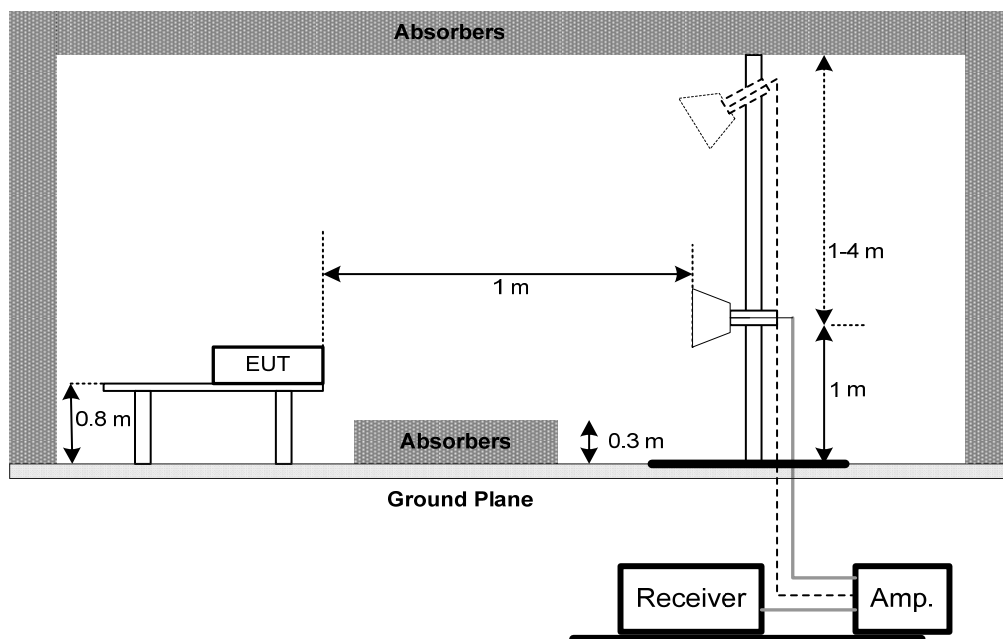
**3.3.5 TEST SETUP****1 GHz-18 GHz****18 GHz-40 GHz**

### 3.3.6 TEST RESULTS

Remark:

- (1) Radiated emissions measured in frequency range above 1000 MHz were made with an instrument using Peak detector mode and AV detector mode of the emission.
- (2) Data of measurement within this frequency range shown “\*” in the table above means the reading of emissions are attenuated more than 20 dB below the permissible limits or the field strength is too small to be measured.
- (3) A preamp and high pass filter were used for this test in order to provide sufficient measurement sensitivity.



Test Voltage	AC 120V/60Hz	Polarization	Vertical
Test Mode	Mode 5(Config1)		

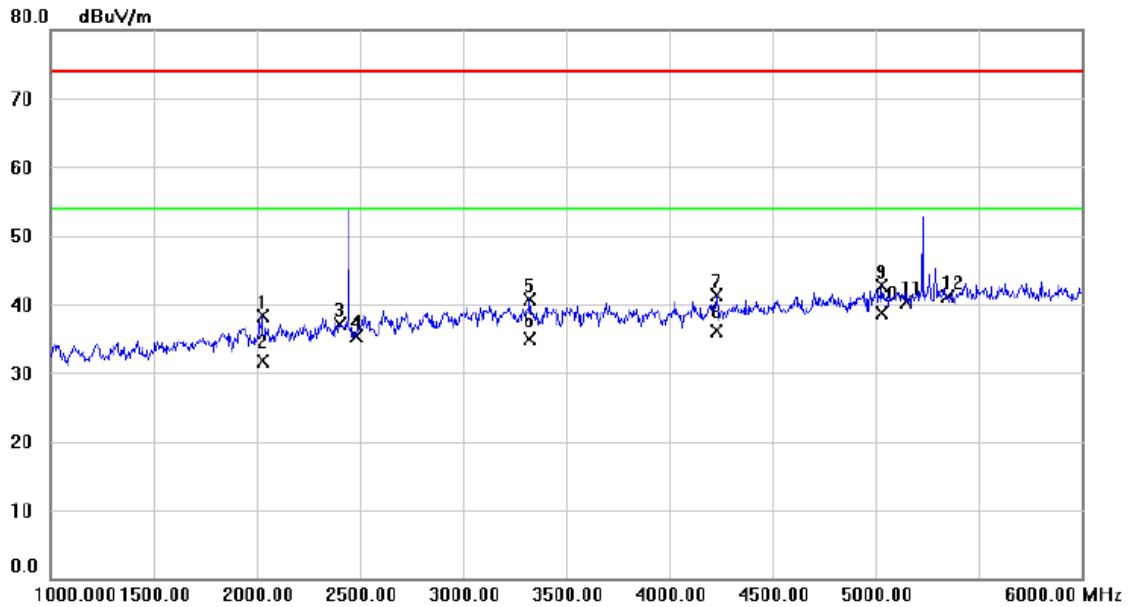

No. Mk.	Freq. MHz	Reading Level dBuV	Correct Factor dB	Measure- ment dBuV/m	Limit dBuV/m	Margin dB	Detector	Comment
1	2027.500	38.66	-0.45	38.21	74.00	-35.79	peak	
2	2027.500	32.17	-0.45	31.72	54.00	-22.28	AVG	
3	2400.000	36.50	0.65	37.15	74.00	-36.85	peak	
4	2483.500	34.33	0.90	35.23	74.00	-38.77	peak	
5	3325.000	37.12	3.55	40.67	74.00	-33.33	peak	
6	3325.000	31.26	3.55	34.81	54.00	-19.19	AVG	
7	4227.500	35.58	5.63	41.21	74.00	-32.79	peak	
8	4227.500	30.41	5.63	36.04	54.00	-17.96	AVG	
9	5032.500	34.12	8.64	42.76	74.00	-31.24	peak	
10 *	5032.500	30.06	8.64	38.70	54.00	-15.30	AVG	
11	5150.000	31.28	8.95	40.23	74.00	-33.77	peak	
12	5350.000	31.67	9.47	41.14	74.00	-32.86	peak	

Test Voltage	AC 120V/60Hz	Polarization	Horizontal
Test Mode	Mode 5(Config1)		

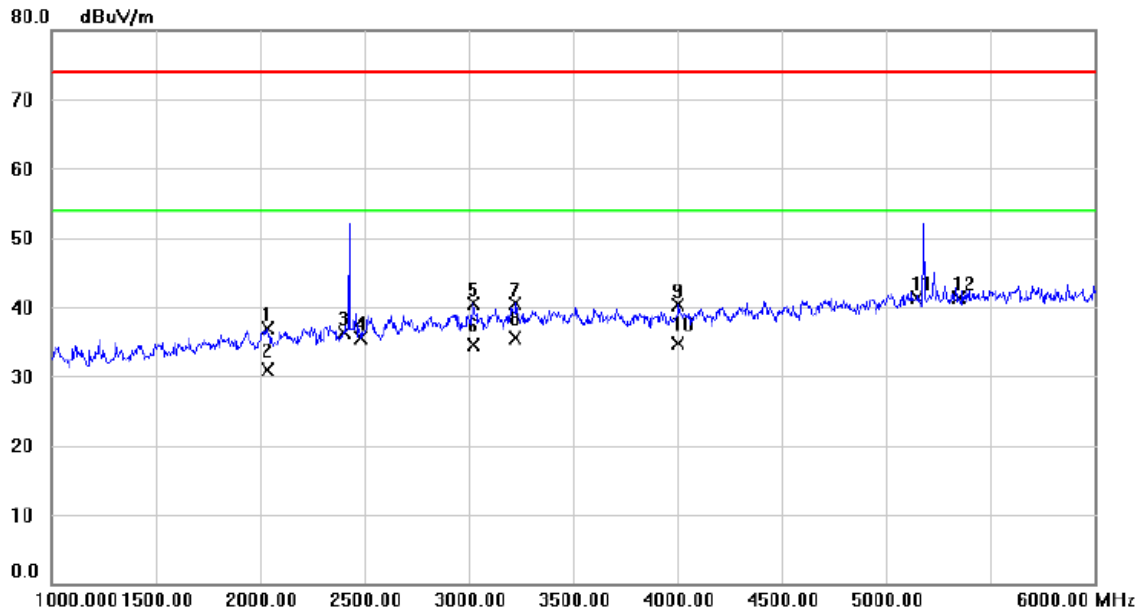

No.	Mk.	Freq. MHz	Reading Level dBuV	Correct Factor dB	Measure- ment dBuV/m	Limit dBuV/m	Margin dB	Detector	Comment
1		2037.500	37.36	-0.43	36.93	74.00	-37.07	peak	
2		2037.500	31.28	-0.43	30.85	54.00	-23.15	AVG	
3		2400.000	35.58	0.65	36.23	74.00	-37.77	peak	
4		2483.500	34.70	0.90	35.60	74.00	-38.40	peak	
5		3020.000	37.54	2.96	40.50	74.00	-33.50	peak	
6		3020.000	31.60	2.96	34.56	54.00	-19.44	AVG	
7		3225.000	37.12	3.36	40.48	74.00	-33.52	peak	
8	*	3225.000	32.14	3.36	35.50	54.00	-18.50	AVG	
9		4005.000	35.40	4.88	40.28	74.00	-33.72	peak	
10		4005.000	29.86	4.88	34.74	54.00	-19.26	AVG	
11		5150.000	32.29	8.95	41.24	74.00	-32.76	peak	
12		5350.000	31.87	9.47	41.34	74.00	-32.66	peak	

Test Voltage	AC 120V/60Hz	Polarization	Vertical
Test Mode	Mode 5(Config1)		

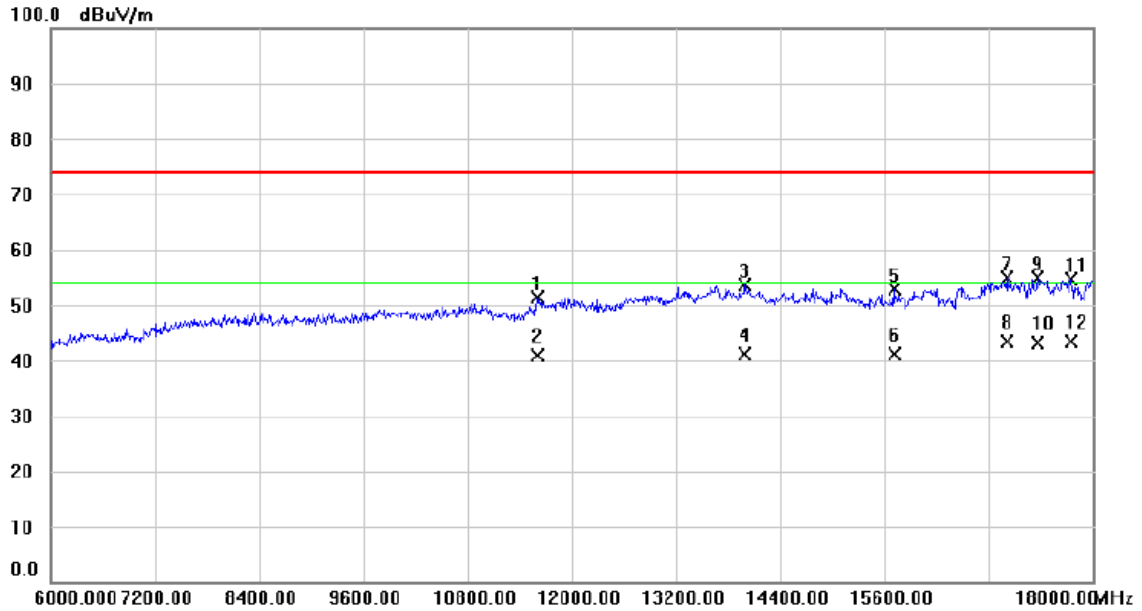

No.	Mk.	Freq. MHz	Reading Level dBuV	Correct Factor dB	Measure- ment dBuV/m	Limit dBuV/m	Margin dB	Detector	Comment
1		11604.00	30.76	20.55	51.31	74.00	-22.69	peak	
2		11604.00	20.26	20.55	40.81	54.00	-13.19	AVG	
3		13992.00	24.81	28.70	53.51	74.00	-20.49	peak	
4		13992.00	12.33	28.70	41.03	54.00	-12.97	AVG	
5		15714.00	29.96	22.80	52.76	74.00	-21.24	peak	
6		15714.00	18.25	22.80	41.05	54.00	-12.95	AVG	
7		17010.00	27.59	27.18	54.77	74.00	-19.23	peak	
8	*	17010.00	16.25	27.18	43.43	54.00	-10.57	AVG	
9		17370.00	26.06	28.81	54.87	74.00	-19.13	peak	
10		17370.00	14.26	28.81	43.07	54.00	-10.93	AVG	
11		17754.00	23.27	31.43	54.70	74.00	-19.30	peak	
12		17754.00	12.00	31.43	43.43	54.00	-10.57	AVG	

Test Voltage	AC 120V/60Hz	Polarization	Horizontal
Test Mode	Mode 5(Config1)		

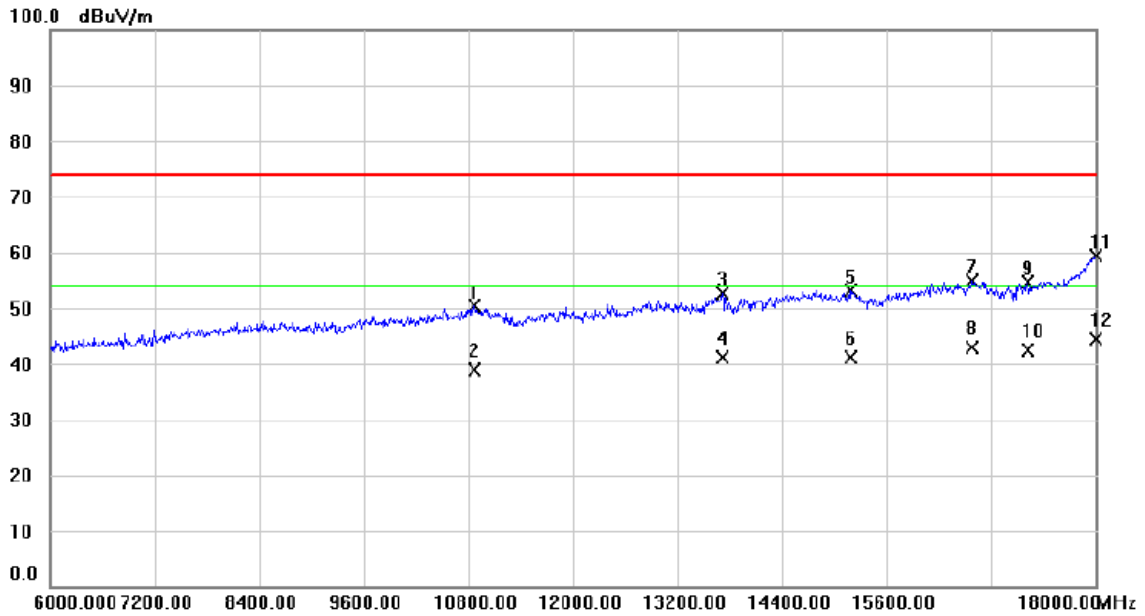

No.	Mk.	Freq. MHz	Reading Level dBuV	Correct Factor dB	Measure- ment dBuV/m	Limit dBuV/m	Margin dB	Detector	Comment
1		10878.00	30.96	19.52	50.48	74.00	-23.52	peak	
2		10878.00	19.25	19.52	38.77	54.00	-15.23	AVG	
3		13722.00	25.92	26.82	52.74	74.00	-21.26	peak	
4		13722.00	14.26	26.82	41.08	54.00	-12.92	AVG	
5		15186.00	28.22	24.86	53.08	74.00	-20.92	peak	
6		15186.00	16.25	24.86	41.11	54.00	-12.89	AVG	
7		16590.00	30.25	24.51	54.76	74.00	-19.24	peak	
8		16590.00	18.25	24.51	42.76	54.00	-11.24	AVG	
9		17226.00	26.45	28.17	54.62	74.00	-19.38	peak	
10		17226.00	14.33	28.17	42.50	54.00	-11.50	AVG	
11		18000.00	25.90	33.39	59.29	74.00	-14.71	peak	
12	*	18000.00	11.00	33.39	44.39	54.00	-9.61	AVG	

Test Voltage	AC 120V/60Hz	Polarization	Vertical
Test Mode	Mode 5(Config1)		

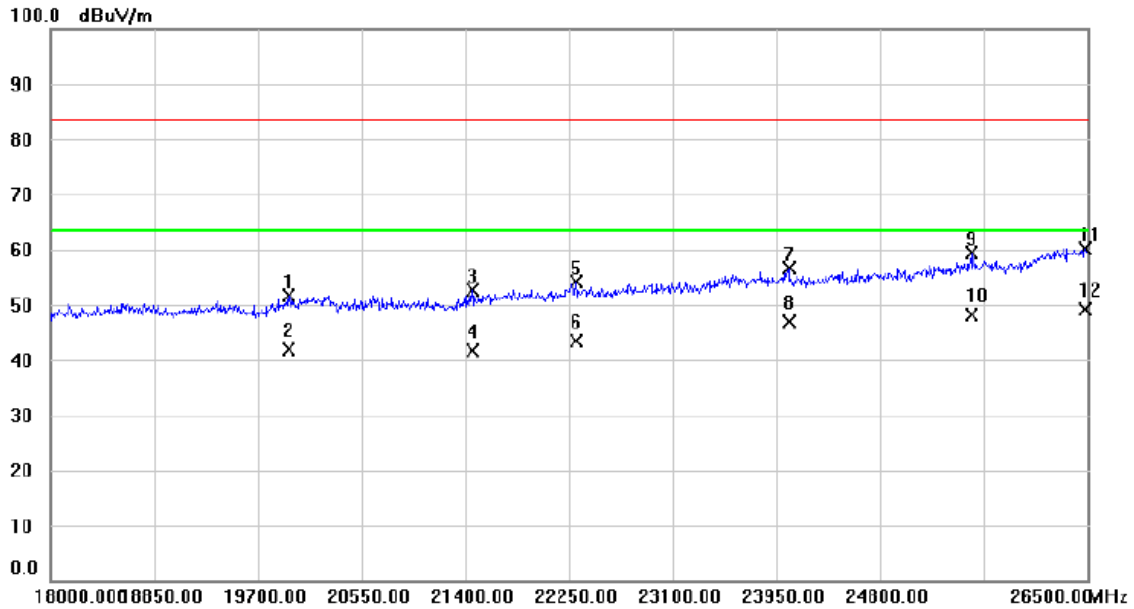

No.	Mk.	Freq. MHz	Reading Level dBuV	Correct Factor dB	Measure- ment dBuV/m	Limit dBuV/m	Margin dB	Detector	Comment
1		19955.00	32.12	19.60	51.72	83.50	-31.78	peak	
2		19955.00	22.33	19.60	41.93	63.50	-21.57	AVG	
3		21459.50	31.27	21.35	52.62	83.50	-30.88	peak	
4		21459.50	20.26	21.35	41.61	63.50	-21.89	AVG	
5		22309.50	32.14	22.07	54.21	83.50	-29.29	peak	
6		22309.50	21.33	22.07	43.40	63.50	-20.10	AVG	
7		24052.00	32.04	24.61	56.65	83.50	-26.85	peak	
8		24052.00	22.33	24.61	46.94	63.50	-16.56	AVG	
9		25556.50	32.53	26.82	59.35	83.50	-24.15	peak	
10		25556.50	21.33	26.82	48.15	63.50	-15.35	AVG	
11		26483.00	32.39	27.81	60.20	83.50	-23.30	peak	
12	*	26483.00	21.33	27.81	49.14	63.50	-14.36	AVG	

Test Voltage	AC 120V/60Hz	Polarization	Horizontal
Test Mode	Mode 5(Config1)		

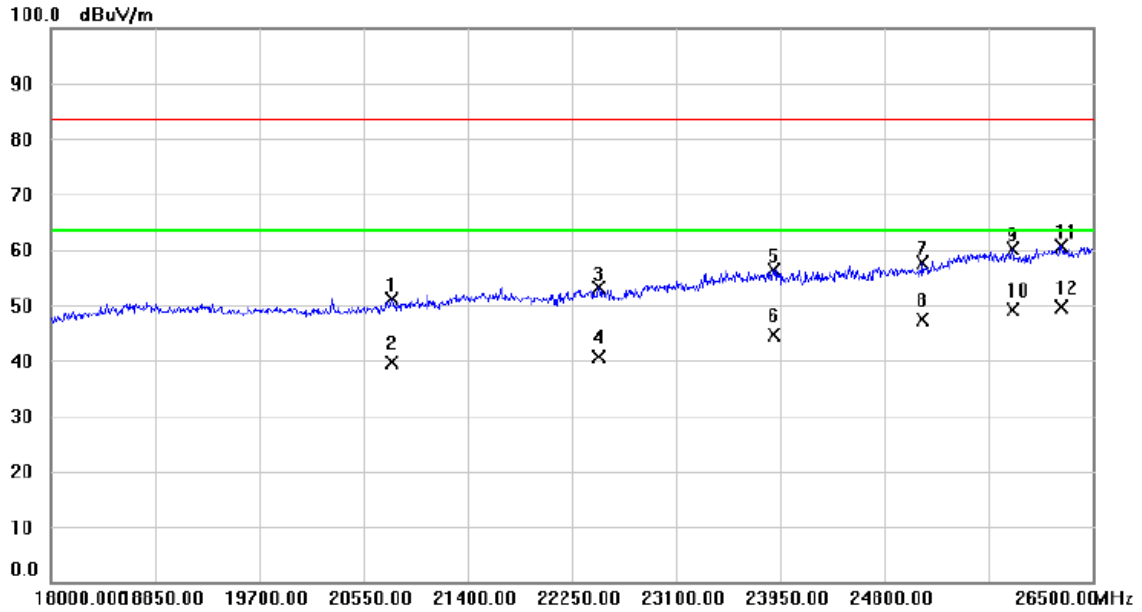

No. Mk.	Freq. MHz	Reading Level dBuV	Correct Factor dB	Measurement dBuV/m	Limit dBuV/m	Margin dB	Detector	Comment
1	20779.50	30.96	20.26	51.22	83.50	-32.28	peak	
2	20779.50	19.25	20.26	39.51	63.50	-23.99	AVG	
3	22471.00	30.84	22.29	53.13	83.50	-30.37	peak	
4	22471.00	18.25	22.29	40.54	63.50	-22.96	AVG	
5	23899.00	31.84	24.45	56.29	83.50	-27.21	peak	
6	23899.00	20.26	24.45	44.71	63.50	-18.79	AVG	
7	25114.50	31.51	26.14	57.65	83.50	-25.85	peak	
8	25114.50	21.33	26.14	47.47	63.50	-16.03	AVG	
9	25845.50	33.29	26.72	60.01	83.50	-23.49	peak	
10	25845.50	22.33	26.72	49.05	63.50	-14.45	AVG	
11	26245.00	33.43	27.24	60.67	83.50	-22.83	peak	
12 *	26245.00	22.33	27.24	49.57	63.50	-13.93	AVG	

Test Voltage	AC 120V/60Hz	Polarization	Vertical
Test Mode	Mode 5(Config1)		

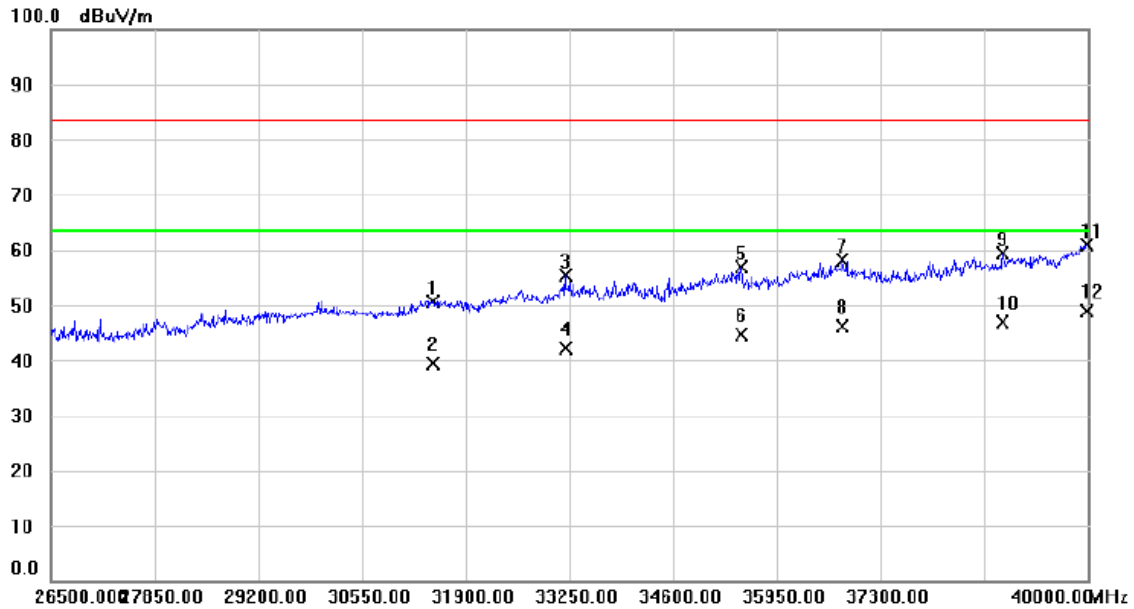

No.	Mk.	Freq. MHz	Reading Level dBuV	Correct Factor dB	Measure- ment dBuV/m	Limit dBuV/m	Margin dB	Detector	Comment
1		31481.50	41.49	9.24	50.73	83.50	-32.77	peak	
2		31481.50	30.26	9.24	39.50	63.50	-24.00	AVG	
3		33196.00	45.71	9.71	55.42	83.50	-28.08	peak	
4		33196.00	32.33	9.71	42.04	63.50	-21.46	AVG	
5		35491.00	45.51	11.27	56.78	83.50	-26.72	peak	
6		35491.00	33.26	11.27	44.53	63.50	-18.97	AVG	
7		36800.50	47.28	10.77	58.05	83.50	-25.45	peak	
8		36800.50	35.33	10.77	46.10	63.50	-17.40	AVG	
9		38893.00	44.73	14.59	59.32	83.50	-24.18	peak	
10		38893.00	32.33	14.59	46.92	63.50	-16.58	AVG	
11		39986.50	43.31	17.56	60.87	83.50	-22.63	peak	
12	*	39986.50	31.33	17.56	48.89	63.50	-14.61	AVG	

Test Voltage	AC 120V/60Hz	Polarization	Horizontal
Test Mode	Mode 5(Config1)		

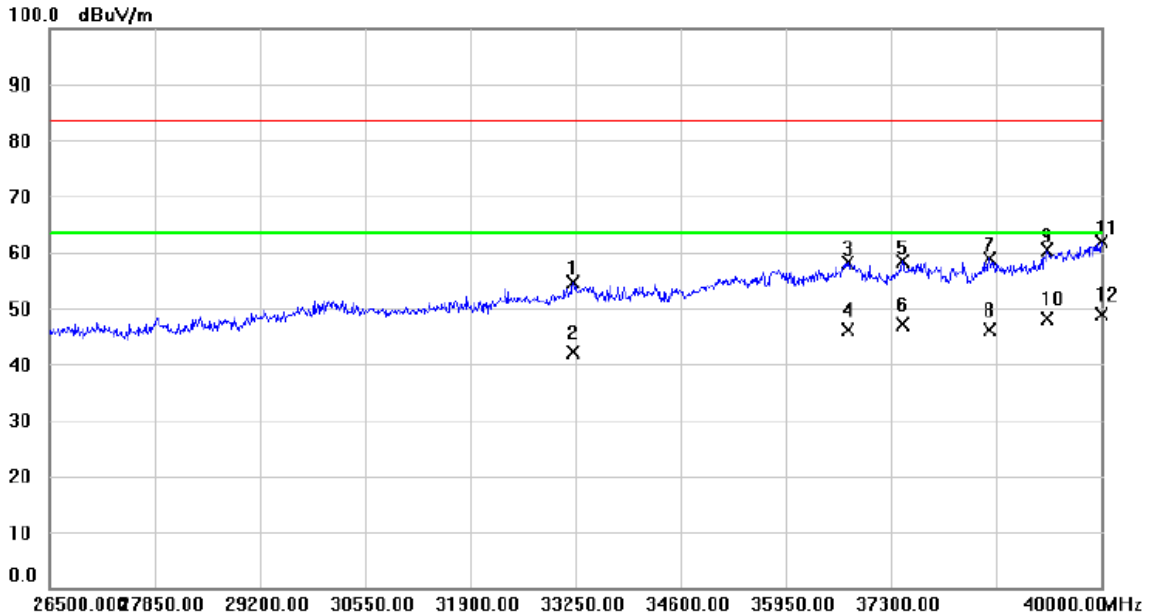

No.	Mk.	Freq. MHz	Reading Level dBuV	Correct Factor dB	Measure- ment dBuV/m	Limit dBuV/m	Margin dB	Detector	Comment
1		33223.00	44.79	9.73	54.52	83.50	-28.98	peak	
2		33223.00	32.33	9.73	42.06	63.50	-21.44	AVG	
3		36746.50	47.28	10.73	58.01	83.50	-25.49	peak	
4		36746.50	35.33	10.73	46.06	63.50	-17.44	AVG	
5		37448.50	47.31	10.95	58.26	83.50	-25.24	peak	
6		37448.50	36.25	10.95	47.20	63.50	-16.30	AVG	
7		38569.00	45.00	13.79	58.79	83.50	-24.71	peak	
8		38569.00	32.33	13.79	46.12	63.50	-17.38	AVG	
9		39311.50	44.60	15.79	60.39	83.50	-23.11	peak	
10		39311.50	32.33	15.79	48.12	63.50	-15.38	AVG	
11		40000.00	44.20	17.60	61.80	83.50	-21.70	peak	
12	*	40000.00	31.33	17.60	48.93	63.50	-14.57	AVG	



#### 4. EUT TEST PHOTO

AC Power Line Conducted Emissions



## Radiated Emissions 30 MHz to 1 GHz

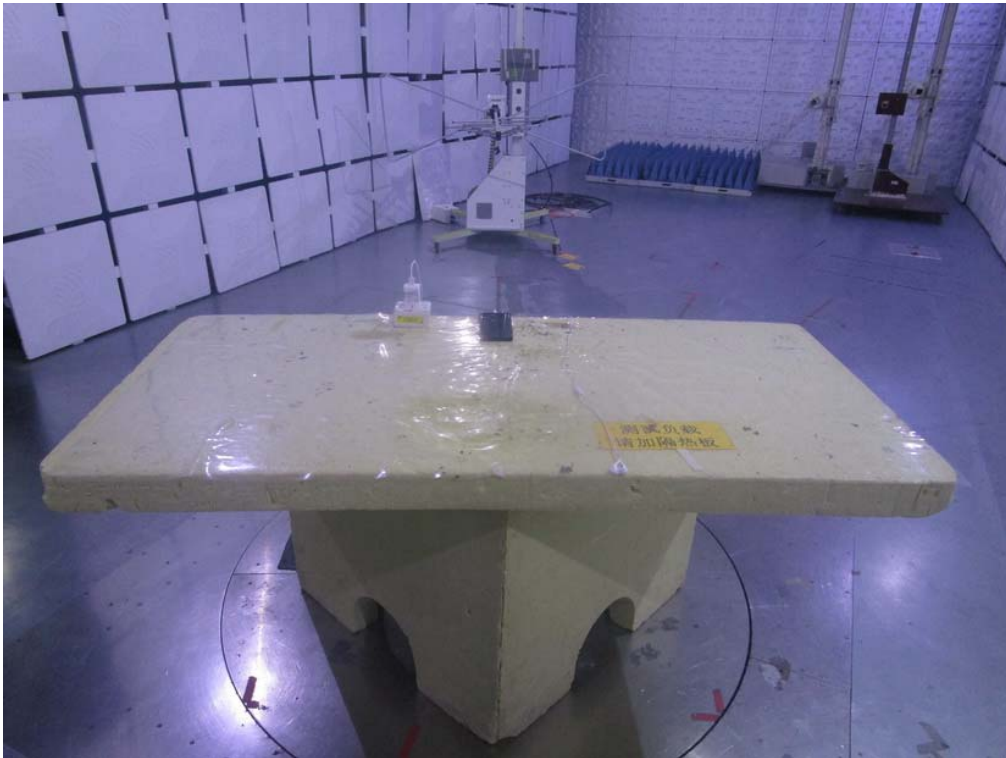

## Radiated Emissions Above 1 GHz

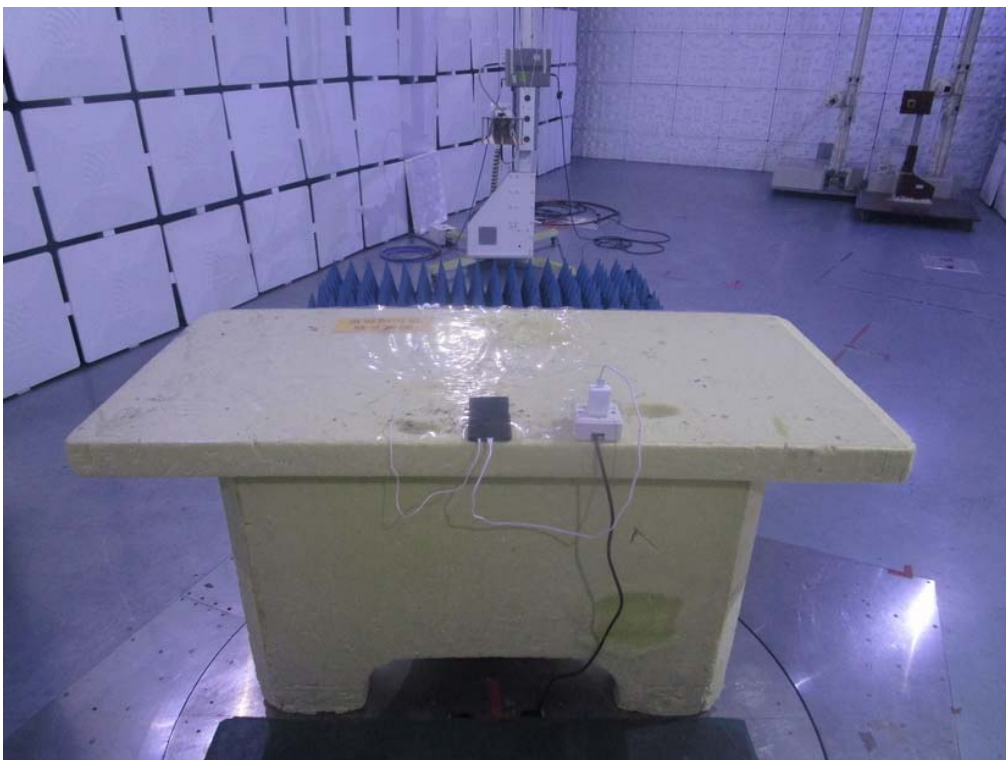
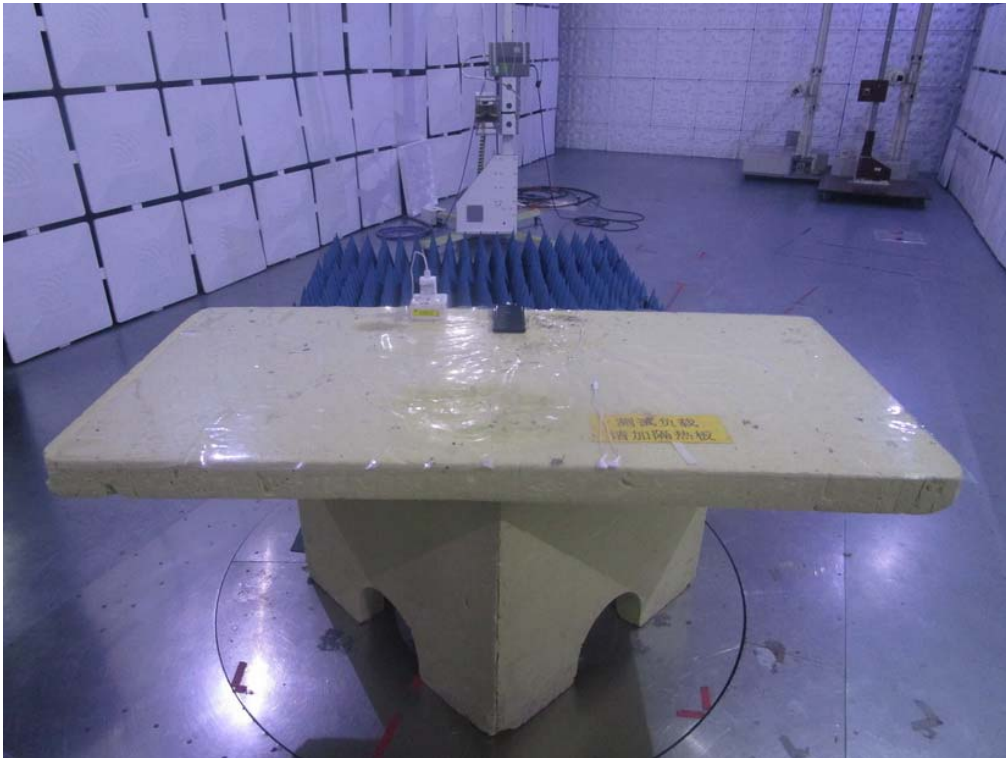

**End of Test Report**