

FCC Radio Test Report

FCC ID: R9C-CPH2127

This report concerns: Original Grant

Project No. : 2006C121
Equipment : Mobile Phone
Brand Name : OPPO
Test Model : CPH2127
Series Model : N/A
Applicant : Guangdong OPPO Mobile Telecommunications Corp., Ltd.
Address : NO.18 HaiBin Road, Wusha Village, Chang An Town, DongGuan City, Guangdong,China
Manufacturer : Guangdong OPPO Mobile Telecommunications Corp., Ltd.
Address : NO.18 HaiBin Road, Wusha Village, Chang An Town, DongGuan City, Guangdong,China
Factory : Guangdong OPPO Mobile Telecommunications Corp., Ltd.
Address : NO.18 HaiBin Road, Wusha Village, Chang An Town, DongGuan City, Guangdong,China
Date of Receipt : Jun. 10, 2020
Date of Test : Jun. 10, 2020 ~ Jul. 01, 2020
Issued Date : Aug. 05, 2020
Report Version : R00
Test Sample : Engineering Sample No.: DG20200609230 for conducted, DG2020061225 for radiated.
Standard(s) : 47 CFR FCC Part 22 Subpart H
47 CFR FCC Part 2
ANSI/TIA/EIA-603-E-2016
FCC KDB 971168 D01 Power Meas License Digital Systems v03r01

The above equipment has been tested and found compliance with the requirement of the relative standards by BTL Inc.

Prepared by : Treey Chen



Approved by : Steven Lu



Certificate #5123.02

Add: No.3, Jinshagang 1st Road, Shixia, Dalang Town, Dongguan, Guangdong, China.

Tel: +86-769-8318-3000

Web: www.newbtl.com

Declaration

BTL represents to the client that testing is done in accordance with standard procedures as applicable and that test instruments used has been calibrated with standards traceable to international standard(s) and/or national standard(s).

BTL's reports apply only to the specific samples tested under conditions. It is manufacture's responsibility to ensure that additional production units of this model are manufactured with the identical electrical and mechanical components. **BTL** shall have no liability for any declarations, inferences or generalizations drawn by the client or others from **BTL** issued reports.

The report must not be used by the client to claim product certification, approval, or endorsement by NIST, A2LA, or any agency of the U.S. Government.

This report is the confidential property of the client. As a mutual protection to the clients, the public and ourselves, the test report shall not be reproduced, except in full, without our written approval.

BTL's laboratory quality assurance procedures are in compliance with the **ISO/IEC 17025** requirements, and accredited by the conformity assessment authorities listed in this test report.

BTL is not responsible for the sampling stage, so the results only apply to the sample as received.

The information, data and test plan are provided by manufacturer which may affect the validity of results, so it is manufacturer's responsibility to ensure that the apparatus meets the essential requirements of applied standards and in all the possible configurations as representative of its intended use.

Limitation

For the use of the authority's logo is limited unless the Test Standard(s)/Scope(s)/Item(s) mentioned in this test report is (are) included in the conformity assessment authorities acceptance respective.

Please note that the measurement uncertainty is provided for informational purpose only and is not use in determining the Pass/Fail results.

Table of Contents	Page
REPORT ISSUED HISTORY	5
1 . SUMMARY OF TEST RESULTS	6
1.1 TEST FACILITY	7
1.2 MEASUREMENT UNCERTAINTY	7
1.3 TEST ENVIRONMENT CONDITIONS	7
2 . GENERAL INFORMATION	8
2.1 GENERAL DESCRIPTION OF EUT	8
2.2 DESCRIPTION OF TEST MODES	11
2.3 BLOCK DIGRAM SHOWING THE CONFIGURATIONOFSYSTEMTESTED	14
3.4 DESCRIPTION OF SUPPORT UNITS	14
3 . TEST RESULT	15
3.1 OUTPUT POWER MEASUREMENT	15
3.1.1 LIMIT	15
3.1.2 TEST PROCEDURE	15
3.1.3 TEST SETUP LAYOUT	15
3.1.4 TEST DEVIATION	15
3.1.5 TEST RESULTS	15
3.2 OCCUPIED BANDWIDTH MEASUREMENT	16
3.2.1 TEST PROCEDURE	16
3.2.2 TEST SETUP LAYOUT	16
3.2.3 TEST DEVIATION	16
3.2.4 TEST RESULTS	16
3.3 CONDUCTED SPURIOUS EMISSIONS MEASUREMENT	17
3.3.1 LIMIT	17
3.3.2 TEST PROCEDURES	17
3.3.3 TEST SETUP LAYOUT	17
3.3.4 TEST DEVIATION	17
3.3.5 TEST RESULTS	17
3.4 RADIATED SPURIOUS EMISSIONS MEASUREMENT	18
3.4.1 LIMIT	18
3.4.2 TEST PROCEDURES	18
3.4.3 TEST SETUP LAYOUT	19
3.4.4 TEST DEVIATION	20
3.4.5 TEST RESULTS (9KHZ TO 30MHZ)	20
3.4.6 TEST RESULTS (30MHZ TO 1000MHZ)	20
3.4.7 TEST RESULTS (ABOVE 1000MHZ)	20
3.5 BAND EDGE MEASUREMENT	21
3.5.1 LIMIT	21

Table of Contents	Page
3.5.2 TEST PROCEDURES	21
3.5.3 TEST SETUP LAYOUT	21
3.5.4 TEST DEVIATION	21
3.5.5 TEST RESULTS	21
3.6 PEAK TO AVERAGE RATIO MEASUREMENT	22
3.6.1 LIMIT	22
3.6.2 TEST PROCEDURES	22
3.6.3 TEST SETUP LAYOUT	22
3.6.4 TEST DEVIATION	22
3.6.5 TEST RESULTS	22
3.7 FREQUENCY STABILITY MEASUREMENT	23
3.7.1 LIMIT	23
3.7.2 TEST PROCEDURES	23
3.7.3 TEST SETUP LAYOUT	23
3.7.4 TEST DEVIATION	23
3.7.5 TEST RESULTS	23
4. LIST OF MEASUREMENT EQUIPMENTS	24
APPENDIX A - OUTPUT POWER	26
APPENDIX B - OCCUPIED BANDWIDTH	39
APPENDIX C - CONDUCTED SPURIOUS EMISSIONS	72
APPENDIX D - RADIATED SPURIOUS EMISSIONS (9KHZ TO 30MHZ)	81
APPENDIX E - RADIATED SPURIOUS EMISSIONS (30MHZ TO 1000MHZ)	86
APPENDIX F - RADIATED SPURIOUS EMISSIONS (ABOVE 1000MHZ)	119
APPENDIX G - BAND EDGE	152
APPENDIX H - PEAK TO AVERAGE RATIO	164
APPENDIX I - FREQUENCY STABILITY	187

REPORT ISSUED HISTORY

Report Version	Description	Issued Date
R00	Original Issue.	Aug. 05, 2020

1. SUMMARY OF TEST RESULTS

Test procedures according to the technical standard(s):

FCC Part 22 Subpart H & Part 2			
Standard(s) Section	Test Item	Judgment	Remark
2.1046 22.913(a)(5)	Effective Radiated Power	PASS	-----
2.1049	Occupied Bandwidth	PASS	-----
2.1051 22.917(a)	Conducted Spurious Emissions	PASS	-----
2.1053 22.917(a)	Radiated Spurious Emissions	PASS	-----
22.917(a)	Band Edge Measurements	PASS	-----
-	Peak To Average Ratio	PASS	Record Only
2.1055 22.355	Frequency Stability	PASS	-----

Note:

(1) "N/A" denotes test is not applicable in this test report.

1.1 TEST FACILITY

The test facilities used to collect the test data in this report is at the location of No.3, Jinshagang 1st Road, Shixia, Dalang Town, Dongguan, Guangdong, China.
 BTL's Test Firm Registration Number for FCC: 357015
 BTL's Designation Number for FCC: CN1240

1.2 MEASUREMENT UNCERTAINTY

ISO/IEC 17025 requires that an estimate of the measurement uncertainties associated with the emissions test results be included in the report. The measurement uncertainties given below are based on a 95% confidence level (based on a coverage factor (k=2))
 The BTL measurement uncertainty as below table:

A. Radiated Measurement:

Test Site	Method	Measurement Frequency Range	Ant. H / V	U,(dB)
DG-CB03 (3m)	CISPR	9KHz ~ 30MHz	V	3.79
		9KHz ~ 30MHz	H	3.57
		30MHz ~ 200MHz	V	4.88
		30MHz ~ 200MHz	H	4.14
		200MHz ~ 1,000MHz	V	4.62
		200MHz ~ 1,000MHz	H	4.80

Test Site	Method	Measurement Frequency Range	U,(dB)
DG-CB03 (3m)	CISPR	1GHz ~ 6GHz	4.58
		6GHz ~ 18GHz	5.18

B. Other Measurement:

Parameter	Uncertainty
Spectrum Bandwidth	±3.8 %
Maximum Output Power	±0.95 dB
Power Spectral Density	±0.86 dB
Frequency Stability	±0.16 dB
Temperature	±0.08 °C
Time	±0.58 %
Supply voltages	±0.3 %

Note: Unless specifically mentioned, the uncertainty of measurement has not been taken into account to declare the compliance or non-compliance to the specification.

1.3 TEST ENVIRONMENT CONDITIONS

Test Item	Temperature	Humidity	Test Voltage	Tested By
Output Power & ERP	21.7°C	43%	DC 3.87V	Tate Liu
Occupied Bandwidth	21.7°C	43%	DC 3.87V	Tate Liu
Conducted Spurious Emissions	21.7°C	43%	DC 3.87V	Tim Yang
Radiated Spurious Emissions	24°C	68%	AC 120V/60Hz	Kwok Guo
Band Edge	21.7°C	43%	DC 3.87V	Tate Liu
Peak to Average Ratio	21.7°C	43%	DC 3.87V	Tate Liu
Frequency Stability	Normal and Extreme			Tate Liu

2. GENERAL INFORMATION

2.1 GENERAL DESCRIPTION OF EUT

Equipment	Mobile Phone						
Brand Name	OPPO						
Test Model	CPH2127						
Series Model	N/A						
Model Difference(s)	N/A						
Hardware Version	11						
Software Version	ColorOS V7.2						
Power Source	1. DC Voltage supplied from AC/DC adapter. 1# Model: OP92KAUH 2# Model: OP92JAUH 2. Supplied from Li-ion Polymer battery. Model: BLP805 3. Supplied from USB port.						
Power Rating	1. I/P: 100-240V~ 50/60Hz 0.5A O/P: 5V---2A or 9V---2A 2. 3.87Vdc, 4890mAh/18.92Wh 3. DC 5V						
IEMI No.	Radiated	869431050019691					
	Conducted	869431050019592					
Modulation Type	GSM	GMSK					
	EDGE/GPRS	GMSK, 8PSK					
	WCDMA/HSDPA/HSUPA	UL: QPSK DL: QPSK, 16QAM					
	LTE	UL: QPSK, 16QAM, 64QAM DL: QPSK, 16QAM, 64QAM					
Max. ERP	GSM 850 / GPRS 850		GMSK	25.53	dBm		
	EDGE 850		8PSK	20.08	dBm		
	WCDMA Band V		QPSK	17.51	dBm		
	HSDPA Band V		QPSK	16.50	dBm		
	HSUPA Band V		QPSK	15.69	dBm		
	LTE	Channel Bandwidth (MHz)	QPSK (dBm)	16QAM (dBm)	64QAM (dBm)		
				1.4	17.99	16.93	15.94
	Band 5			3	17.98	17.02	16.15
				5	17.95	17.09	15.93
				10	18.07	17.07	16.14
				1.4	17.10	16.53	15.45
	Band 26			3	17.14	16.63	15.56
				5	17.00	16.52	15.71
				10	17.14	16.79	15.73
15				17.20	16.38	15.40	

Note:

1. For a more detailed features description, please refer to the manufacturer's specifications or the user's manual.

2. Channel List:

GSM 850				
Test Frequency ID	UARFCN	Frequency of Uplink (MHz)	UARFCN	Frequency of Downlink (MHz)
Low Range	128	824.2	137	869.2
Mid Range	190	836.6	199	881.6
High Range	251	848.8	260	893.8

WCDMA Band V				
Test Frequency ID	UARFCN	Frequency of Uplink (MHz)	UARFCN	Frequency of Downlink (MHz)
Low Range	4132	826.4	4357	871.4
Mid Range	4182	836.4	4407	881.4
High Range	4233	846.6	4458	891.6

LTE Band 5					
Test Frequency ID	Bandwidth (MHz)	N _{UL}	Frequency of Uplink (MHz)	N _{DL}	Frequency of Downlink (MHz)
Low Range	1.4	20407	824.7	2407	869.7
	3	20415	825.5	2415	870.5
	5	20425	826.5	2425	871.5
	10	20450	829	2450	874
Mid Range	1.4/3/5/10	20525	836.5	2525	881.5
High Range	1.4	20643	848.3	2643	893.3
	3	20635	847.5	2635	892.5
	5	20625	846.5	2625	891.5
	10	20600	844	2600	889

LTE Band 26					
Test Frequency ID	Bandwidth (MHz)	N _{UL}	Frequency of Uplink (MHz)	N _{DL}	Frequency of Downlink (MHz)
Low Range	1.4	26797	824.7	8797	869.7
	3	26805	825.5	8805	870.5
	5	26815	826.5	8815	871.5
	10	26840	829	8840	874
	15	26865	831.5	8865	876.5
Mid Range	1.4/3/5/10/15	26915	836.5	8915	881.5
High Range	1.4	27033	848.3	9033	893.3
	3	27025	847.5	9025	892.5
	5	27015	846.5	9015	891.5
	10	26990	844	8990	889
	15	26965	841.5	8965	886.5

3. Table for Filed Antenna:

Main Antenna

Brand	Model Name	Antenna Type	Connector	Gain (dBi)	Note
N/A	N/A	Internal	N/A	-3.7	GSM 850
N/A	N/A	Internal	N/A	-3.7	WCDMA Band V
N/A	N/A	Internal	N/A	-3.7	LTE Band 5
N/A	N/A	Internal	N/A	-3.8	LTE Band 26

Second Antenna

Brand	Model Name	Antenna Type	Connector	Gain (dBi)	Note
N/A	N/A	Internal	N/A	-8.7	GSM 850
N/A	N/A	Internal	N/A	-8.7	WCDMA Band V
N/A	N/A	Internal	N/A	-8.7	LTE Band 5
N/A	N/A	Internal	N/A	-8.6	LTE Band 26

2.2 DESCRIPTION OF TEST MODES

Following mode(s) is (were) found to be the worst case(s) and selected for the final test.

GSM MODE			
Test Item	Available Channel	Tested Channel	Mode
Output Power & ERP	128 to 251	128, 190, 251	GSM, GPRS, EDGE
Occupied Bandwidth	128 to 251	128, 190, 251	GSM, EDGE
Conducted Spurious Emissions	128 to 251	190	GSM, EDGE
Radiated Spurious Emissions	128 to 251	190	GSM
Band Edge	128 to 251	128, 251	GSM, EDGE
Peak to Average Ratio	128 to 251	128, 190, 251	GSM, EDGE
Frequency Stability	128 to 251	190	GSM

WCDMA BAND V MODE			
Test Item	Available Channel	Tested Channel	Mode
Output Power & ERP	4132 to 4233	4132, 4182, 4233	WCDMA, HSDPA, HSUPA
Occupied Bandwidth	4132 to 4233	4132, 4182, 4233	WCDMA, HSDPA, HSUPA
Conducted Spurious Emissions	4132 to 4233	4182	WCDMA
Radiated Spurious Emissions	4132 to 4233	4182	WCDMA
Band Edge	4132 to 4233	4132, 4233	WCDMA, HSDPA, HSUPA
Peak to Average Ratio	4132 to 4233	4132, 4182, 4233	WCDMA, HSDPA, HSUPA
Frequency Stability	4132 to 4233	4182	WCDMA

LTE BAND 5 MODE					
Test Item	Available Channel	Tested Channel	Channel Bandwidth	Modulation	Mode
Output Power & ERP	20407 to 20643	20407, 20525, 20643	1.4MHz	QPSK, 16QAM,64QAM	1RB/3RB/6RB
	20415 to 20635	20415, 20525, 20635	3MHz	QPSK, 16QAM,64QAM	1RB/8RB/15RB
	20425 to 20625	20425, 20525, 20625	5MHz	QPSK, 16QAM,64QAM	1RB/12RB/25RB
	20450 to 20600	20450, 20525, 20600	10MHz	QPSK, 16QAM,64QAM	1RB/25RB/50RB
Occupied Bandwidth	20407 to 20643	20407, 20525, 20643	1.4MHz	QPSK, 16QAM,64QAM	6RB
	20415 to 20635	20415, 20525, 20635	3MHz	QPSK, 16QAM,64QAM	15RB
	20425 to 20625	20425, 20525, 20625	5MHz	QPSK, 16QAM,64QAM	25RB
	20450 to 20600	20450, 20525, 20600	10MHz	QPSK, 16QAM,64QAM	50RB
Conducted Spurious Emissions	20407 to 20643	20525	1.4MHz	QPSK	1RB
	20425 to 20625	20525	5MHz	QPSK	1RB
	20450 to 20600	20525	10MHz	QPSK	1RB
Radiated Spurious Emissions	20407 to 20643	20525	1.4MHz	QPSK	1RB
	20425 to 20625	20525	5MHz	QPSK	1RB
	20450 to 20600	20525	10MHz	QPSK	1RB
Band Edge	20407 to 20643	20407, 20643	1.4MHz	QPSK	1RB/6RB
	20415 to 20635	20415, 20635	3MHz	QPSK	1RB/15RB
	20425 to 20625	20425, 20625	5MHz	QPSK	1RB/25RB
	20450 to 20600	20450, 20600	10MHz	QPSK	1RB/50RB
Peak To Average Ratio	20407 to 20643	20407, 20525, 20643	1.4MHz	QPSK, 16QAM,64QAM	1RB
	20415 to 20635	20415, 20525, 20635	3MHz	QPSK, 16QAM,64QAM	1RB
	20425 to 20625	20425, 20525, 20625	5MHz	QPSK, 16QAM,64QAM	1RB
	20450 to 20600	20450, 20525, 20600	10MHz	QPSK, 16QAM,64QAM	1RB
Frequency Stability	20407 to 20643	20525	1.4MHz	QPSK	1RB
	20415 to 20635	20525	3MHz	QPSK	1RB
	20425 to 20625	20525	5MHz	QPSK	1RB
	20450 to 20600	20525	10MHz	QPSK	1RB

LTE BAND 26 MODE					
Test Item	Available Channel	Tested Channel	Channel Bandwidth	Modulation	Mode
Output Power & ERP	26797 to 27033	26797, 26915, 27033	1.4MHz	QPSK, 16QAM, 64QAM	1RB/3RB/6RB
	26805 to 27025	26805, 26915, 27025	3MHz	QPSK, 16QAM, 64QAM	1RB/8RB/15RB
	26815 to 27015	26815, 26915, 27015	5MHz	QPSK, 16QAM, 64QAM	1RB/12RB/25RB
	26840 to 26990	26840, 26915, 26990	10MHz	QPSK, 16QAM, 64QAM	1RB/25RB/50RB
	26865 to 26965	26865, 26915, 26965	15MHz	QPSK, 16QAM, 64QAM	1RB/36RB/75RB
Occupied Bandwidth	26797 to 27033	26797, 26915, 27033	1.4MHz	QPSK, 16QAM, 64QAM	6RB
	26805 to 27025	26805, 26915, 27025	3MHz	QPSK, 16QAM, 64QAM	15RB
	26815 to 27015	26815, 26915, 27015	5MHz	QPSK, 16QAM, 64QAM	25RB
	26840 to 26990	26840, 26915, 26990	10MHz	QPSK, 16QAM, 64QAM	50RB
	26865 to 26965	26865, 26915, 26965	15MHz	QPSK, 16QAM, 64QAM	75RB
Conducted Spurious Emissions	26815 to 27015	226915	1.4MHz	QPSK	1RB
	26815 to 27015	226915	5MHz	QPSK	1RB
	26865 to 26965	226915	15MHz	QPSK	1RB
Radiated Spurious Emissions	26815 to 27015	226915	1.4MHz	QPSK	1RB
	26815 to 27015	226915	5MHz	QPSK	1RB
	26865 to 26965	226915	15MHz	QPSK	1RB
Band Edge	26797 to 27033	26797, 27033	1.4MHz	QPSK	1RB 6RB
	26805 to 27025	26805, 27025	3MHz	QPSK	1RB 15RB
	26815 to 27015	26815, 27015	5MHz	QPSK	1RB 25RB
	26840 to 26990	26840, 26990	10MHz	QPSK	1RB 50RB
	26865 to 26965	26865, 26965	15MHz	QPSK	1RB 75RB
Peak To Average Ratio	26797 to 27033	26797, 26915, 27033	1.4MHz	QPSK, 16QAM, 64QAM	1RB
	26805 to 27025	26805, 26915, 27025	3MHz	QPSK, 16QAM, 64QAM	1RB
	26815 to 27015	26815, 26915, 27015	5MHz	QPSK, 16QAM, 64QAM	1RB
	26840 to 26990	26840, 26915, 26990	10MHz	QPSK, 16QAM, 64QAM	1RB
	26865 to 26965	26865, 26915, 26965	15MHz	QPSK, 16QAM, 64QAM	1RB
Frequency Stability	26797 to 27033	226915	1.4MHz	QPSK	1RB
	26805 to 27025	226915	3MHz	QPSK	1RB
	26815 to 27015	226915	5MHz	QPSK	1RB
	26840 to 26990	226915	10MHz	QPSK	1RB
	26865 to 26965	226915	15MHz	QPSK	1RB

2.3 BLOCK DIGRAM SHOWING THE CONFIGURATION OF SYSTEM TESTED

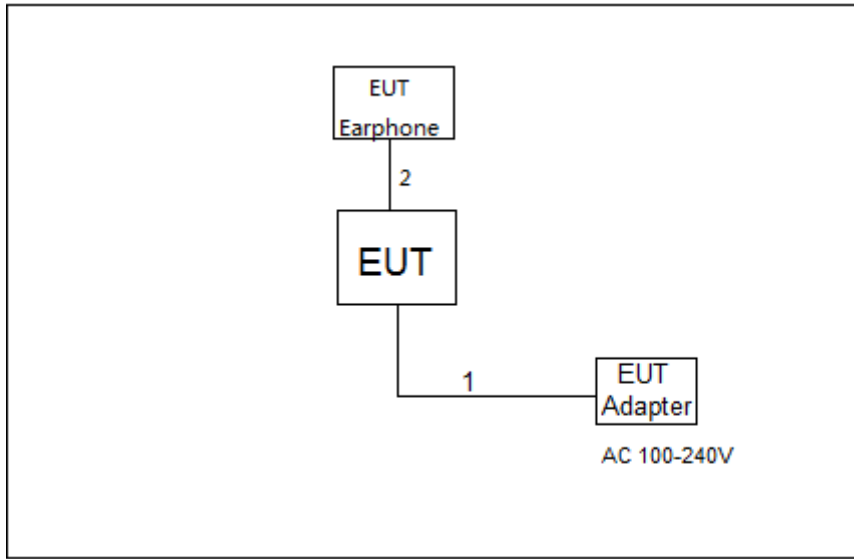

3.4 DESCRIPTION OF SUPPORT UNITS

The EUT has been tested as an independent unit together with other necessary accessories or support units. The following support units or accessories were used to form a representative test configuration during the tests.

Item	Equipment	Mfr/Brand	Model/Type No.	Series No.
-	-	-	-	-

Item	Cable Type	Shielded Type	Ferrite Core	Length
1	USB Cable	YES	NO	1m
2	Audio Cable	NO	NO	1m

3. TEST RESULT

3.1 OUTPUT POWER MEASUREMENT

3.1.1 LIMIT

Mobile / Portable station are limited to 7 watts e.r.p.

3.1.2 TEST PROCEDURE

The testing follows FCC KDB 971168 v03r01 Section 5.

EIRP / ERP:

EIRP = Output Power + Antenan gain

ERP = EIPR - 2.15dBi

Output Power:

The EUT was set up for the maximum power with GSM, GPRS, EDGE, WCDMA and LTE link data modulation and link up with simulator. Set the EUT to transmit under low, middle and high channel and record the power level shown on simulator.

3.1.3 TEST SETUP LAYOUT

Output Power Measurement

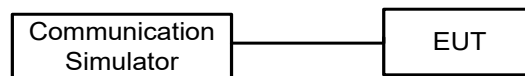

3.1.4 TEST DEVIATION

No deviation

3.1.5 TEST RESULTS

Please refer to the APPENDIX A.

3.2 OCCUPIED BANDWIDTH MEASUREMENT

3.2.1 TEST PROCEDURE

The testing follows FCC KDB 971168 v03r01 Section 4.

1. The EUT makes a call to the communication simulator. All measurements were done at low, middle and high operational frequency range. The communication simulator station system controlled a EUT to export maximum output power under transmission mode and specific channel frequency. Use OBW measurement function of Spectrum analyzer to measure 99 % occupied bandwidth and 26dB bandwidth.
2. The EUT was connected to spectrum analyzer and system simulator via a power divider.
3. $RBW=(1\% \sim 5\%)*EBW$
 $VBW \geq 3* RBW$
4. Set spectrum analyzer with Peak detector.

3.2.2 TEST SETUP LAYOUT

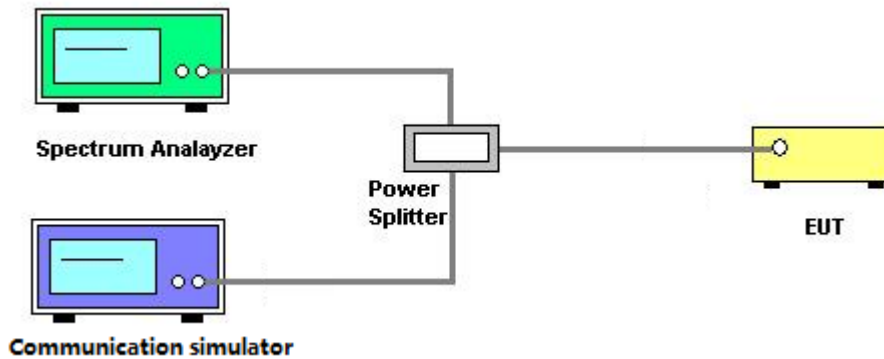

3.2.3 TEST DEVIATION

No deviation

3.2.4 TEST RESULTS

Please refer to the APPENDIX B.

3.3 CONDUCTED SPURIOUS EMISSIONS MEASUREMENT

3.3.1 LIMIT

The power of any emission outside of the authorized operating frequency ranges must be attenuated below the transmitting power (P) by a factor of at least $43 + 10 \log(P)$ dB. The emission limit equal to -13dBm.

3.3.2 TEST PROCEDURES

The testing follows FCC KDB 971168 v03r01 Section 6.

1. The EUT was connected to spectrum analyzer and system simulator via a power divider.
2. The band edges of low and high channels for the highest RF powers were measured. Set RBW $\geq 1\%$ EBW in the 1MHz band immediately outside and adjacent to the band edge.
3. Set spectrum analyzer with Peak detector.
4. The RF fundamental frequency should be excluded against the limit line in the operating frequency band.

3.3.3 TEST SETUP LAYOUT

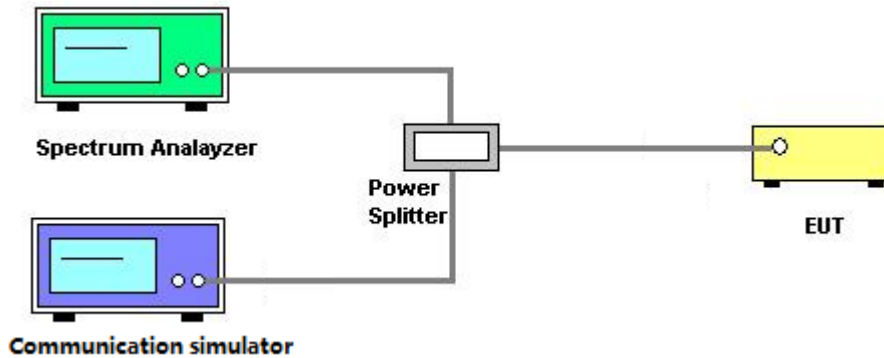

3.3.4 TEST DEVIATION

No deviation

3.3.5 TEST RESULTS

Please refer to the APPENDIX C.

3.4 RADIATED SPURIOUS EMISSIONS MEASUREMENT

3.4.1 LIMIT

The power of any emission outside of the authorized operating frequency ranges must be attenuated below the transmitting power (P) by a factor of at least $43 + 10 \log(P)$ dB. The emission limit equal to -13dBm.

3.4.2 TEST PROCEDURES

The testing follows FCC KDB 971168 v03r01 Section 6.2.

1. Substitution method is used for E.I.R.P measurement. In the semi-anechoic chamber, EUT placed on the 0.8m height of Turn Table, rotated the table around 360 degrees to search the maximum radiation power and receiver antenna shall be rotated vertical and horizontal polarization and moved height from 1m to 4m to find the maximum polar radiated power. The "Read Value" is the spectrum reading the maximum power value.
2. The substitution horn antenna is substituted for EUT at the same position and signals generator export the CW signal to the substitution antenna via a TX cable. Rotated the Turn Table and moved receiving antenna to find the maximum radiation power. Adjust output power level of S.G to get a Value of spectrum reading equal to "Read Value " of step a. Record the power level of S.G
3. $EIRP = \text{Output power level of S.G} - \text{TX cable loss} + \text{Antenna gain of substitution horn}$.
4. ERP can be calculated form EIRP by subtracting the gain of dipole, $ERP = EIPR - 2.15\text{dBi}$.
5. The resolution bandwidth and video bandwidth of test receiver/spectrum analyzer is 1MHz/3MHz.

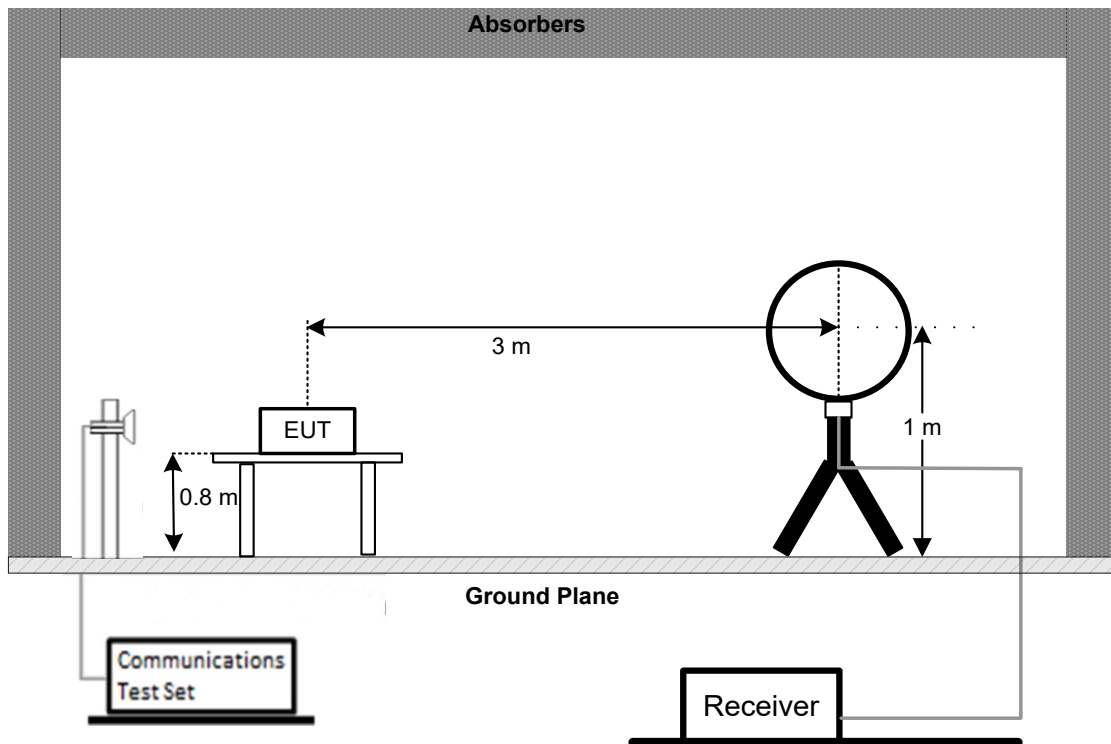
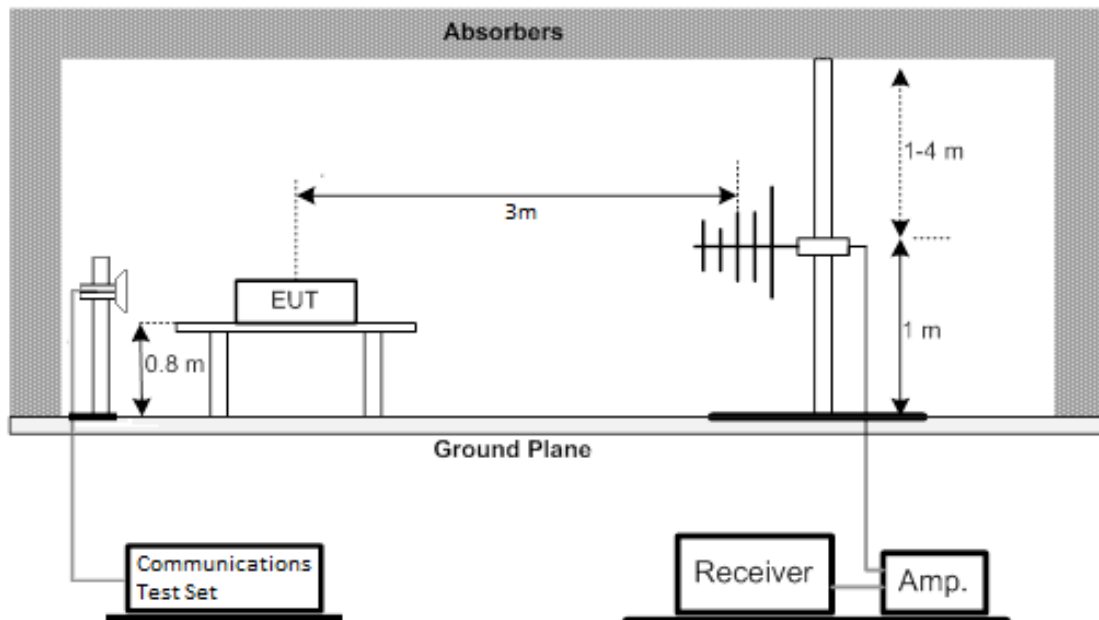
3.4.3 TEST SETUP LAYOUT**Below 30MHz****30MHz to 1000MHz**

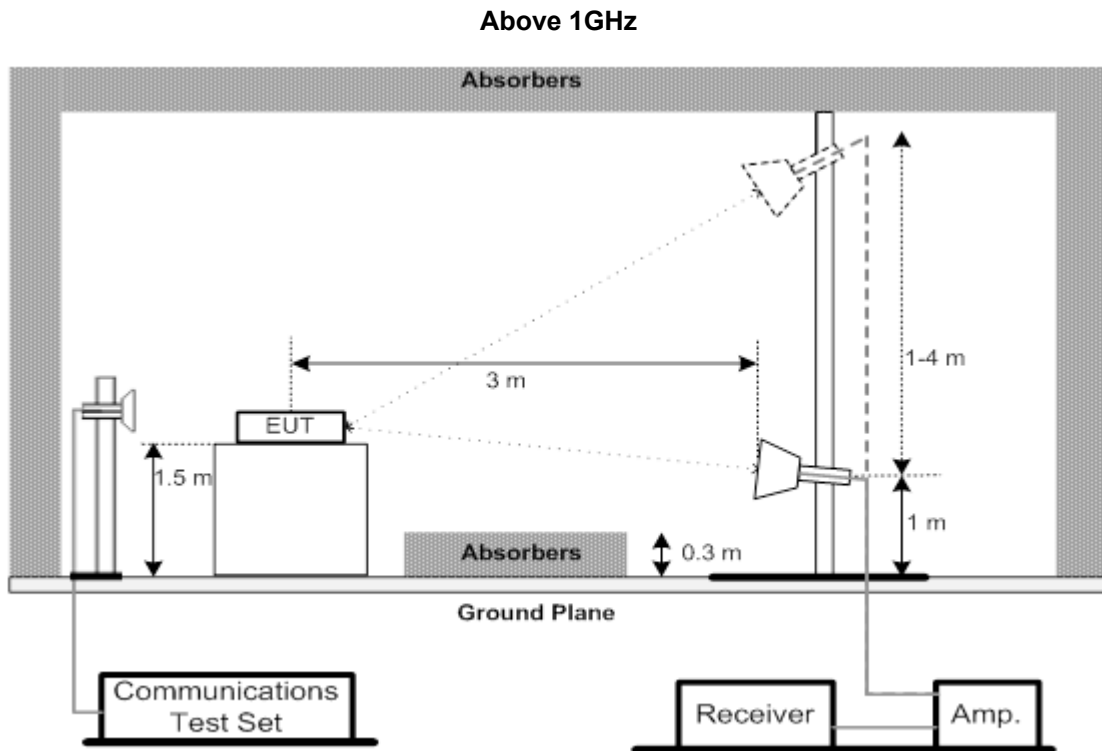

3.4.4 TEST DEVIATION

No deviation

3.4.5 TEST RESULTS (9KHZ TO 30MHZ)

Please refer to the APPENDIX D.

3.4.6 TEST RESULTS (30MHZ TO 1000MHZ)

Please refer to the APPENDIX E.

3.4.7 TEST RESULTS (ABOVE 1000MHZ)

Please refer to the APPENDIX F.

3.5 BAND EDGE MEASUREMENT

3.5.1 LIMIT

A Power of any emission outside of the authorized operating frequency ranges must be attenuated below the transmitting power (P) by a factor of at least $43 + 10 \log(P)$ dB. In the 1 MHz bands immediately outside and adjacent to the frequency block a resolution bandwidth of at least one percent of the emission bandwidth of the fundamental emission of the transmitter may be employed.

3.5.2 TEST PROCEDURES

The testing follows FCC KDB 971168 v03r01 Section 6.

1. All measurements were done at low and high operational frequency range.
2. Record the max trace plot into the test report.

3.5.3 TEST SETUP LAYOUT

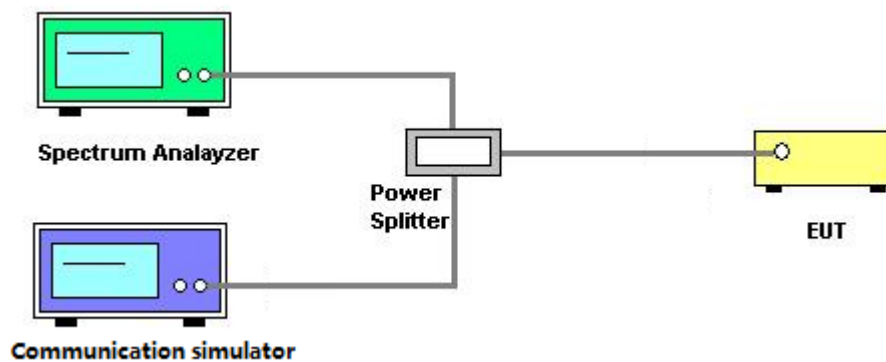

3.5.4 TEST DEVIATION

No deviation

3.5.5 TEST RESULTS

Please refer to the APPENDIX G.

3.6 PEAK TO AVERAGE RATIO MEASUREMENT

3.6.1 LIMIT

In measuring transmissions in this band using an average power technique, the peak to-average ratio (PAR) of the transmission may not exceed 13 dB.

3.6.2 TEST PROCEDURES

The testing follows FCC KDB 971168 v03r01 Section 5.7.

1. Set resolution/measurement bandwidth \geq signal's occupied bandwidth;
2. Set the number of counts to a value that stabilizes the measured CCDF curve;
3. Record the maximum PAPR level associated with a probability of 0.1%.

3.6.3 TEST SETUP LAYOUT

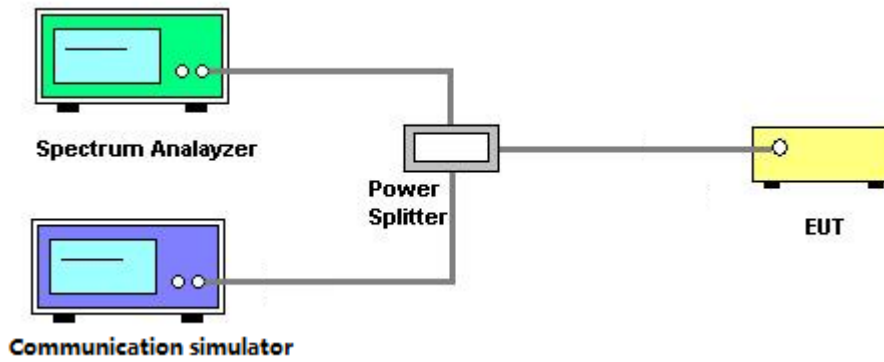

3.6.4 TEST DEVIATION

No deviation

3.6.5 TEST RESULTS

Please refer to the APPENDIX H.

3.7 FREQUENCY STABILITY MEASUREMENT

3.7.1 LIMIT

± 1.5 ppm is for base and fixed station. ± 2.5 ppm is for mobile station.

3.7.2 TEST PROCEDURES

The testing follows FCC KDB 971168 v03r01 Section 9.

1. Device is placed at the oven room. The oven room could control the temperatures and humidity. Power warm up is at least 15 min and power applied should perform before recording frequency error.
2. EUT is connected the external power supply to control the DC input power. The test voltage range is from minimum to maximum working voltage. Each step shall be record the frequency error rate.
3. The temperature range step is 10 degrees in this test items. All temperature levels shall be hold the $\pm 0.5^{\circ}\text{C}$ during the measurement testing. The each temperature step shall be at least 0.5 hours, consider the EUT could be test under the stability condition.
4. The frequency error was recorded frequency error from the communication simulator.

3.7.3 TEST SETUP LAYOUT

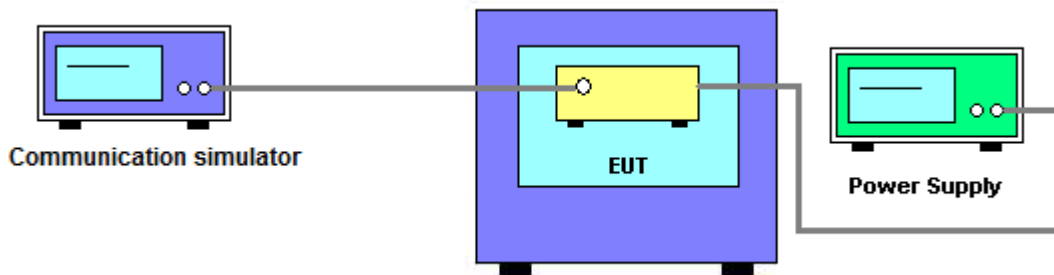

3.7.4 TEST DEVIATION

No deviation

3.7.5 TEST RESULTS

Please refer to the APPENDIX I.

4. LIST OF MEASUREMENT EQUIPMENTS

Radiated Spurious Emission Measurement					
Item	Kind of Equipment	Manufacturer	Type No.	Serial No.	Calibrated until
1	Antenna	Schwarzbeck	VULB9160	9160-3232	Mar. 09, 2021
2	Amplifier	Agilent	8449B	3008A02334	Mar. 01, 2021
3	High Pass Filter	Wairwright Instruments Gmbh	WHK 1.5/15G-10ST	11	Feb. 28, 2021
4	Band Reject Filter	Wairwright Instruments Gmbh	WRCG 1710/1785-1690/1805-60/12SS	38	Feb. 28, 2021
5	Band Reject Filter	Wairwright Instruments Gmbh	WRCG 824/849-810/863-60/9SS	7	Feb. 28, 2021
6	Band Reject Filter	Wairwright Instruments Gmbh	WRCG 880/915-860/935-60/9SS	14	Feb. 28, 2021
7	Band Reject Filter	Wairwright Instruments Gmbh	WRCG 1850/1910-1830/1930-60/10SS	17	Feb. 28, 2021
8	High Pass Filter	Wairwright Instruments Gmbh	WHK3.1/18G-10SS	24	Feb. 28, 2021
9	Wireless Communication Test SET	Agilent	E5515C	MY48364183	Mar. 01, 2021
10	Microwave Preamplifier With Adaptor	EMC INSTRUMENT	EMC2654045	980039 & HA01	Mar. 07, 2021
11	Receiver	Agilent	N9038A	MY52130039	Jul. 25, 2021
12	wideband radio communication tester	R&S	CMW500	152372	Feb. 28, 2021
13	High pass filter	KANGMAIWEI	ZHPF-M3-12.75G-3869	B2015073763	Feb. 11, 2021
14	High pass filter	KANGMAIWEI	ZHPF-M1000-4000-1	B2015073762	Feb. 11, 2021
15	High pass filter	KANGMAIWEI	ZHPF-M6-186-1727	B2015073764	Feb. 11, 2021
16	Cable	emci	LMR-400(30MHz-1GHz)(8m+5m)	N/A	May 23, 2021
17	Cable	mitron	B10-01-01-12M	18072744	Jun. 28, 2021
18	Controller	ETS-Lindgren	2090	N/A	N/A
19	Measurement Software	Farad	EZ-EMC Ver.NB-03A1-01	N/A	N/A
20	Loop Antenna	EM	EM-6876-1	230	Apr. 16, 2021
21	Double Ridged Guide Antenna	ETS	3115	75846	Mar. 19, 2021
22	Broad-Band Horn Antenna	Schwarzbeck	BBHA 9170	9170319	Jul. 07, 2021

Conducted Measurement					
Item	Kind of Equipment	Manufacturer	Type No.	Serial No.	Calibrated until
1	Wireless Communication Test SET	Agilent	E5515C	MY48364183	Mar. 01, 2021
2	EXA Spectrum Analyzer	Agilent	N9010A	MY50520044	Mar. 01, 2021
3	POWER SPLITTER	Mini-Circuits	ZFRSC-123-S+	331000910-1	Feb. 28, 2021
4	wideband radio communication tester	R&S	CMW500	152372	Feb. 28, 2021

Frequency Stability Measurement					
Item	Kind of Equipment	Manufacturer	Type No.	Serial No.	Calibrated until
1	Wireless Communication Test SET	Agilent	E5515C	MY48364183	Mar. 01, 2021
2	Multi-output DC Power Supply	GW Instek	GPC-3030DN	EK880675	Sep. 26, 2020
3	POWER SPLITTER	Mini-Circuits	ZFRSC-123-S+	331000910-1	Feb. 28, 2021
4	wideband radio communication tester	R&S	CMW500	152372	Feb. 28, 2021
5	Const Temp, & Humidity Chamber	Bell	BTH-50C	20170306001	Feb. 28, 2021

Remark: "N/A" denotes no model name, serial no. or calibration specified.

All calibration period of equipment list is one year.

APPENDIX A - OUTPUT POWER

Output Power (dBm):

GSM850		128CH	190CH	251CH
		824.2MHz	836.6MHz	848.8MHz
GSM (CS)		31.12	31.28	31.38
GPRS/EDGE (GMSK)	1 Tx Slot	31.12	31.28	31.38
	2 Tx Slot	29.06	29.34	29.57
	3 Tx Slot	26.50	26.34	26.75
	4 Tx Slot	25.76	26.02	26.14
EDGE (8PSK)	1 Tx Slot	25.93	25.85	25.75
	2 Tx Slot	23.98	23.90	24.01
	3 Tx Slot	22.57	22.41	22.31
	4 Tx Slot	21.60	21.52	21.54

Modulation	Band	WCDMA Band V		
	Tx Channel	4132CH	4182CH	4233CH
	Frequency	826.4MHz	836.4MHz	846.6MHz
QPSK	RMC 12.2K	22.96	23.22	23.36
	RMC 64K	23.03	23.18	23.30
	RMC 144K	22.83	23.04	23.34
	RMC 384K	22.95	23.16	23.30
	HSDPA Subtest-1	22.05	22.23	22.35
	HSDPA Subtest-2	22.06	22.20	22.31
	HSDPA Subtest-3	21.52	21.74	21.83
	HSDPA Subtest-4	21.55	21.68	21.84
	HSUPA Subtest-1	21.26	21.35	21.54
	HSUPA Subtest-2	19.99	20.23	20.35
	HSUPA Subtest-3	20.86	21.01	21.12
	HSUPA Subtest-4	19.96	20.17	20.32
	HSUPA Subtest-5	21.05	21.18	21.31

LTE Band / BW	Modulation	RB Size	RB Offset	Low CH	Mid CH	High CH
				20407CH	20525CH	20643CH
				824.7MHz	836.5MHz	848.3MHz
5 / 1.4M	QPSK	1	0	23.47	23.42	23.47
		1	2	23.46	23.67	23.76
		1	5	23.44	23.65	23.84
		3	0	23.43	23.57	23.70
		3	1	23.50	23.65	23.74
		3	2	23.44	23.60	23.76
		6	0	22.37	22.56	22.64
	16QAM	1	0	22.47	22.50	22.65
		1	2	22.41	22.78	22.52
		1	5	22.50	22.73	22.57
		3	0	22.60	22.63	22.55
		3	1	22.61	22.69	22.61
		3	2	22.64	22.62	22.60
		6	0	21.55	21.72	21.59
	64QAM	1	0	21.58	21.75	21.64
		1	2	21.56	21.66	21.61
		1	5	21.50	21.69	21.54
		3	0	21.61	21.62	21.77
		3	1	21.65	21.65	21.79
		3	2	21.68	21.63	21.78
		6	0	20.74	20.71	20.69

LTE Band / BW	Modulation	RB Size	RB Offset	Low CH	Mid CH	High CH
				20415CH	20525CH	20635CH
				825.5MHz	836.5MHz	847.5MHz
5 / 3M	QPSK	1	0	23.31	23.44	23.54
		1	7	23.51	23.79	23.83
		1	14	23.35	23.70	23.76
		8	0	22.27	22.60	22.65
		8	4	22.32	22.59	22.75
		8	7	22.23	22.56	22.68
		15	0	22.30	22.56	22.69
	16QAM	1	0	22.33	22.87	22.52
		1	7	22.40	22.53	22.77
		1	14	22.31	22.53	22.74
		8	0	21.37	21.69	21.67
		8	4	21.43	21.69	21.76
		8	7	21.37	21.64	21.74
		15	0	21.34	21.63	21.67
	64QAM	1	0	21.83	21.55	21.82
		1	7	21.80	21.89	21.76
		1	14	21.86	21.83	22.00
		8	0	20.38	20.70	20.62
		8	4	20.43	20.69	20.70
		8	7	20.38	20.66	20.68
		15	0	20.36	20.68	20.79

LTE Band / BW	Modulation	RB Size	RB Offset	Low CH	Mid CH	High CH
				20425CH	20525CH	20625CH
				826.5MHz	836.5MHz	846.5MHz
5 / 5M	QPSK	1	0	23.53	23.59	23.55
		1	13	23.57	23.78	23.78
		1	24	23.43	23.70	23.80
		12	0	22.44	22.59	22.74
		12	6	22.41	22.62	22.82
		12	11	22.47	22.59	22.86
		25	0	22.40	22.61	22.77
	16QAM	1	0	22.67	22.64	22.67
		1	13	22.71	22.79	22.84
		1	24	22.57	22.77	22.94
		12	0	21.50	21.74	21.80
		12	6	21.44	21.74	21.84
		12	11	21.57	21.74	21.88
		25	0	21.44	21.65	21.72
	64QAM	1	0	21.44	21.78	21.76
		1	13	21.50	21.70	21.70
		1	24	21.36	21.70	21.73
		12	0	20.51	20.57	20.80
		12	6	20.46	20.59	20.85
		12	11	20.57	20.56	20.88
		25	0	20.44	20.59	20.80

LTE Band / BW	Modulation	RB Size	RB Offset	Low CH	Mid CH	High CH
				20450CH	20525CH	20600CH
				829.0MHz	836.5MHz	844.0MHz
5 / 10M	QPSK	1	0	23.52	23.74	23.92
		1	25	23.37	23.68	23.85
		1	49	23.75	23.61	23.82
		25	0	22.44	22.68	22.84
		25	13	22.49	22.63	22.88
		25	25	22.52	22.72	22.97
		50	0	22.41	22.70	22.93
	16QAM	1	0	22.59	22.69	22.92
		1	25	22.49	22.91	22.85
		1	49	22.73	22.83	22.85
		25	0	21.42	21.95	22.00
		25	13	21.47	21.90	21.66
		25	25	21.56	21.62	21.69
		50	0	21.41	21.53	21.67
	64QAM	1	0	21.91	21.76	21.99
		1	25	21.72	21.63	21.96
		1	49	21.63	21.81	21.94
		25	0	20.56	20.77	20.85
		25	13	20.59	20.72	20.92
		25	25	20.67	20.79	20.98
		50	0	20.47	20.75	20.87

LTE Band / BW	Modulation	RB Size	RB Offset	Low CH	Mid CH	High CH
				CH26797	CH26915	CH27033
				824.7MHz	836.5MHz	848.3MHz
26 / 1.4M	QPSK	1	0	22.87	22.60	22.61
		1	2	22.97	23.02	22.82
		1	5	22.81	22.96	22.78
		3	0	22.90	22.96	22.74
		3	1	22.92	23.05	22.75
		3	2	22.85	23.04	22.84
	16QAM	6	0	21.72	21.90	22.05
		1	0	22.09	22.35	21.85
		1	2	22.17	22.48	22.41
		1	5	22.05	22.25	22.48
		3	0	21.96	22.29	22.16
		3	1	22.13	22.41	22.20
	64QAM	3	2	22.00	22.32	22.24
		6	0	21.04	21.06	21.16
		1	0	21.15	21.12	21.28
		1	2	21.18	21.37	21.40
		1	5	21.05	21.40	21.38
		3	0	21.09	21.04	21.02
		3	1	21.18	21.06	20.98
		3	2	21.16	21.09	21.00
		6	0	20.28	20.18	20.36

LTE Band / BW	Modulation	RB Size	RB Offset	Low CH	Mid CH	High CH
				CH26805	CH26915	CH27025
				825.5MHz	836.5MHz	847.5MHz
26 / 3M	QPSK	1	0	22.72	22.87	22.62
		1	7	22.78	23.09	22.86
		1	14	22.78	22.89	22.79
		8	0	22.04	22.19	22.36
		8	4	22.07	22.16	22.40
		8	7	22.01	22.11	22.45
	16QAM	15	0	21.99	22.18	22.39
		1	0	22.22	22.44	21.89
		1	7	22.11	22.58	22.39
		1	14	22.12	22.47	22.47
		8	0	21.21	21.47	21.37
		8	4	21.28	21.44	21.43
	64QAM	8	7	21.23	21.37	21.45
		15	0	21.08	21.35	21.31
		1	0	21.26	21.32	20.93
		1	7	21.26	21.51	21.19
		1	14	21.25	21.45	21.19
		8	0	19.92	20.19	20.36
		8	4	20.00	20.14	20.41
		8	7	19.93	20.05	20.43
		15	0	19.97	20.03	20.42

LTE Band / BW	Modulation	RB Size	RB Offset	Low CH	Mid CH	High CH
				CH26815	CH26915	CH27015
				826.5MHz	836.5MHz	846.5MHz
26 / 5M	QPSK	1	0	22.74	22.67	22.62
		1	13	22.95	22.91	22.72
		1	24	22.79	22.68	22.87
		12	0	22.01	22.14	22.39
		12	6	21.99	22.11	22.33
		12	11	21.94	22.11	22.38
		25	0	22.00	22.15	22.37
	16QAM	1	0	22.28	22.23	22.40
		1	13	22.35	22.47	22.22
		1	24	22.25	22.42	22.31
		12	0	21.29	21.31	21.23
		12	6	21.23	21.33	21.19
		12	11	21.18	21.27	21.23
		25	0	21.11	21.27	21.47
	64QAM	1	0	20.96	21.42	21.10
		1	13	21.08	21.51	21.17
		1	24	20.99	21.66	21.36
		12	0	20.14	20.22	20.41
		12	6	20.10	20.24	20.39
		12	11	20.04	20.16	20.42
		25	0	20.07	20.29	20.40

LTE Band / BW	Modulation	RB Size	RB Offset	Low CH	Mid CH	High CH
				CH26840	CH26915	CH26990
				829MHz	836.5MHz	844MHz
26 / 10M	QPSK	1	0	22.99	22.97	22.80
		1	25	22.78	22.87	22.76
		1	49	23.09	22.81	22.84
		25	0	22.16	22.51	22.40
		25	13	22.12	22.37	22.40
		25	25	22.25	22.43	22.44
		50	0	22.25	22.37	22.46
	16QAM	1	0	22.35	22.54	22.30
		1	25	22.22	22.50	22.39
		1	49	22.50	22.74	22.38
		25	0	21.26	21.54	21.17
		25	13	21.25	21.44	21.16
		25	25	21.27	21.49	21.21
		50	0	21.24	21.41	21.17
	64QAM	1	0	21.68	21.56	21.21
		1	25	21.54	21.43	21.19
		1	49	21.52	21.58	21.21
		25	0	20.29	20.55	20.45
		25	13	20.24	20.48	20.47
		25	25	20.26	20.53	20.21
		50	0	20.23	20.42	20.44

LTE Band / BW	Modulation	RB Size	RB Offset	Low CH	Mid CH	High CH
				CH26865	CH26915	CH26965
				831.5MHz	836.5MHz	841.5MHz
26 / 15M	QPSK	1	0	22.97	22.48	22.40
		1	38	23.15	22.57	22.71
		1	74	22.61	22.64	22.37
		36	0	21.29	22.64	21.56
		36	18	21.67	21.52	21.80
		36	39	21.60	21.48	21.67
		75	0	21.43	21.45	21.67
	16QAM	1	0	21.90	21.82	22.04
		1	38	22.13	21.91	22.33
		1	74	21.67	21.72	21.95
		36	0	20.43	20.64	21.17
		36	18	20.83	20.78	21.39
		36	39	20.77	20.74	21.24
		75	0	20.60	20.66	21.21
	64QAM	1	0	20.99	20.56	21.01
		1	38	21.21	20.67	21.35
		1	74	20.74	20.74	21.06
		36	0	19.08	20.74	19.60
		36	18	19.48	19.47	19.85
		36	39	19.42	19.44	19.73
		75	0	19.24	19.34	19.74

ERP (dBm):

GSM850		128CH	190CH	251CH
		824.2MHz	836.6MHz	848.8MHz
GSM (CS)		25.27	25.43	25.53
GPRS/EDGE (GMSK)	1 Tx Slot	25.27	25.43	25.53
	2 Tx Slot	23.21	23.49	23.72
	3 Tx Slot	20.65	20.49	20.90
	4 Tx Slot	19.91	20.17	20.29
EDGE (8PSK)	1 Tx Slot	20.08	20.00	19.90
	2 Tx Slot	18.13	18.05	18.16
	3 Tx Slot	16.72	16.56	16.46
	4 Tx Slot	15.75	15.67	15.69

Modulation	Band	WCDMA Band V		
	Tx Channel	4132CH	4182CH	4233CH
	Frequency	826.4MHz	836.4MHz	846.6MHz
QPSK	RMC 12.2K	17.11	17.37	17.51
	RMC 64K	17.18	17.33	17.45
	RMC 144K	16.98	17.19	17.49
	RMC 384K	17.10	17.31	17.45
	HSDPA Subtest-1	16.20	16.38	16.50
	HSDPA Subtest-2	16.21	16.35	16.46
	HSDPA Subtest-3	15.67	15.89	15.98
	HSDPA Subtest-4	15.70	15.83	15.99
	HSUPA Subtest-1	15.41	15.50	15.69
	HSUPA Subtest-2	14.14	14.38	14.50
	HSUPA Subtest-3	15.01	15.16	15.27
	HSUPA Subtest-4	14.11	14.32	14.47
	HSUPA Subtest-5	15.20	15.33	15.46

LTE Band / BW	Modulation	RB Size	RB Offset	Low CH	Mid CH	High CH
				20407CH	20525CH	20643CH
				824.7MHz	836.5MHz	848.3MHz
5 / 1.4M	QPSK	1	0	17.62	17.57	17.62
		1	2	17.61	17.82	17.91
		1	5	17.59	17.80	17.99
		3	0	17.58	17.72	17.85
		3	1	17.65	17.80	17.89
		3	2	17.59	17.75	17.91
	16QAM	6	0	16.52	16.71	16.79
		1	0	16.62	16.65	16.80
		1	2	16.56	16.93	16.67
		1	5	16.65	16.88	16.72
		3	0	16.75	16.78	16.70
		3	1	16.76	16.84	16.76
	64QAM	3	2	16.79	16.77	16.75
		6	0	15.70	15.87	15.74
		1	0	15.73	15.90	15.79
		1	2	15.71	15.81	15.76
		1	5	15.65	15.84	15.69
		3	0	15.76	15.77	15.92
		3	1	15.80	15.80	15.94
		3	2	15.83	15.78	15.93
		6	0	14.89	14.86	14.84

LTE Band / BW	Modulation	RB Size	RB Offset	Low CH	Mid CH	High CH
				20415CH	20525CH	20635CH
				825.5MHz	836.5MHz	847.5MHz
5 / 3M	QPSK	1	0	17.46	17.59	17.69
		1	7	17.66	17.94	17.98
		1	14	17.50	17.85	17.91
		8	0	16.42	16.75	16.80
		8	4	16.47	16.74	16.90
		8	7	16.38	16.71	16.83
		15	0	16.45	16.71	16.84
	16QAM	1	0	16.48	17.02	16.67
		1	7	16.55	16.68	16.92
		1	14	16.46	16.68	16.89
		8	0	15.52	15.84	15.82
		8	4	15.58	15.84	15.91
		8	7	15.52	15.79	15.89
		15	0	15.49	15.78	15.82
	64QAM	1	0	15.98	15.70	15.97
		1	7	15.95	16.04	15.91
		1	14	16.01	15.98	16.15
		8	0	14.53	14.85	14.77
		8	4	14.58	14.84	14.85
		8	7	14.53	14.81	14.83
		15	0	14.51	14.83	14.94

LTE Band / BW	Modulation	RB Size	RB Offset	Low CH	Mid CH	High CH
				20425CH	20525CH	20625CH
				826.5MHz	836.5MHz	846.5MHz
5 / 5M	QPSK	1	0	17.68	17.74	17.70
		1	13	17.72	17.93	17.93
		1	24	17.58	17.85	17.95
		12	0	16.59	16.74	16.89
		12	6	16.56	16.77	16.97
		12	11	16.62	16.74	17.01
		25	0	16.55	16.76	16.92
	16QAM	1	0	16.82	16.79	16.82
		1	13	16.86	16.94	16.99
		1	24	16.72	16.92	17.09
		12	0	15.65	15.89	15.95
		12	6	15.59	15.89	15.99
		12	11	15.72	15.89	16.03
		25	0	15.59	15.80	15.87
	64QAM	1	0	15.59	15.93	15.91
		1	13	15.65	15.85	15.85
		1	24	15.51	15.85	15.88
		12	0	14.66	14.72	14.95
		12	6	14.61	14.74	15.00
		12	11	14.72	14.71	15.03
		25	0	14.59	14.74	14.95

LTE Band / BW	Modulation	RB Size	RB Offset	Low CH	Mid CH	High CH
				20450CH	20525CH	20600CH
				829.0MHz	836.5MHz	844.0MHz
5 / 10M	QPSK	1	0	17.67	17.89	18.07
		1	25	17.52	17.83	18.00
		1	49	17.90	17.76	17.97
		25	0	16.59	16.83	16.99
		25	13	16.64	16.78	17.03
		25	25	16.67	16.87	17.12
		50	0	16.56	16.85	17.08
	16QAM	1	0	16.74	16.84	17.07
		1	25	16.64	17.06	17.00
		1	49	16.88	16.98	17.00
		25	0	15.57	16.10	16.15
		25	13	15.62	16.05	15.81
		25	25	15.71	15.77	15.84
		50	0	15.56	15.68	15.82
	64QAM	1	0	16.06	15.91	16.14
		1	25	15.87	15.78	16.11
		1	49	15.78	15.96	16.09
		25	0	14.71	14.92	15.00
		25	13	14.74	14.87	15.07
		25	25	14.82	14.94	15.13
		50	0	14.62	14.90	15.02

LTE Band / BW	Modulation	RB Size	RB Offset	Low CH	Mid CH	High CH
				CH26797	CH26915	CH27033
				824.7MHz	836.5MHz	848.3MHz
26 / 1.4M	QPSK	1	0	16.92	16.65	16.66
		1	2	17.02	17.07	16.87
		1	5	16.86	17.01	16.83
		3	0	16.95	17.01	16.79
		3	1	16.97	17.10	16.80
		3	2	16.90	17.09	16.89
		6	0	15.77	15.95	16.10
	16QAM	1	0	16.14	16.40	15.90
		1	2	16.22	16.53	16.46
		1	5	16.10	16.30	16.53
		3	0	16.01	16.34	16.21
		3	1	16.18	16.46	16.25
		3	2	16.05	16.37	16.29
		6	0	15.09	15.11	15.21
	64QAM	1	0	15.20	15.17	15.33
		1	2	15.23	15.42	15.45
		1	5	15.10	15.45	15.43
		3	0	15.14	15.09	15.07
		3	1	15.23	15.11	15.03
		3	2	15.21	15.14	15.05
		6	0	14.33	14.23	14.41

LTE Band / BW	Modulation	RB Size	RB Offset	Low CH	Mid CH	High CH
				CH26805	CH26915	CH27025
				825.5MHz	836.5MHz	847.5MHz
26 / 3M	QPSK	1	0	16.77	16.92	16.67
		1	7	16.83	17.14	16.91
		1	14	16.83	16.94	16.84
		8	0	16.09	16.24	16.41
		8	4	16.12	16.21	16.45
		8	7	16.06	16.16	16.50
		15	0	16.04	16.23	16.44
	16QAM	1	0	16.27	16.49	15.94
		1	7	16.16	16.63	16.44
		1	14	16.17	16.52	16.52
		8	0	15.26	15.52	15.42
		8	4	15.33	15.49	15.48
		8	7	15.28	15.42	15.50
		15	0	15.13	15.40	15.36
	64QAM	1	0	15.31	15.37	14.98
		1	7	15.31	15.56	15.24
		1	14	15.30	15.50	15.24
		8	0	13.97	14.24	14.41
		8	4	14.05	14.19	14.46
		8	7	13.98	14.10	14.48
		15	0	14.02	14.08	14.47

LTE Band / BW	Modulation	RB Size	RB Offset	Low CH	Mid CH	High CH
				CH26815	CH26915	CH27015
				826.5MHz	836.5MHz	846.5MHz
26 / 5M	QPSK	1	0	16.79	16.72	16.67
		1	13	17.00	16.96	16.77
		1	24	16.84	16.73	16.92
		12	0	16.06	16.19	16.44
		12	6	16.04	16.16	16.38
		12	11	15.99	16.16	16.43
		25	0	16.05	16.20	16.42
	16QAM	1	0	16.33	16.28	16.45
		1	13	16.40	16.52	16.27
		1	24	16.30	16.47	16.36
		12	0	15.34	15.36	15.28
		12	6	15.28	15.38	15.24
		12	11	15.23	15.32	15.28
		25	0	15.16	15.32	15.52
	64QAM	1	0	15.01	15.47	15.15
		1	13	15.13	15.56	15.22
		1	24	15.04	15.71	15.41
		12	0	14.19	14.27	14.46
		12	6	14.15	14.29	14.44
		12	11	14.09	14.21	14.47
		25	0	14.12	14.34	14.45

LTE Band / BW	Modulation	RB Size	RB Offset	Low CH	Mid CH	High CH
				CH26840	CH26915	CH26990
				829MHz	836.5MHz	844MHz
26 / 10M	QPSK	1	0	17.04	17.02	16.85
		1	25	16.83	16.92	16.81
		1	49	17.14	16.86	16.89
		25	0	16.21	16.56	16.45
		25	13	16.17	16.42	16.45
		25	25	16.30	16.48	16.49
		50	0	16.30	16.42	16.51
	16QAM	1	0	16.40	16.59	16.35
		1	25	16.27	16.55	16.44
		1	49	16.55	16.79	16.43
		25	0	15.31	15.59	15.22
		25	13	15.30	15.49	15.21
		25	25	15.32	15.54	15.26
		50	0	15.29	15.46	15.22
	64QAM	1	0	15.73	15.61	15.26
		1	25	15.59	15.48	15.24
		1	49	15.57	15.63	15.26
		25	0	14.34	14.60	14.50
		25	13	14.29	14.53	14.52
		25	25	14.31	14.58	14.26
		50	0	14.28	14.47	14.49

LTE Band / BW	Modulation	RB Size	RB Offset	Low CH	Mid CH	High CH
				CH26865	CH26915	CH26965
				831.5MHz	836.5MHz	841.5MHz
26 / 15M	QPSK	1	0	17.02	16.53	16.45
		1	38	17.20	16.62	16.76
		1	74	16.66	16.69	16.42
		36	0	15.34	16.69	15.61
		36	18	15.72	15.57	15.85
		36	39	15.65	15.53	15.72
		75	0	15.48	15.50	15.72
	16QAM	1	0	15.95	15.87	16.09
		1	38	16.18	15.96	16.38
		1	74	15.72	15.77	16.00
		36	0	14.48	14.69	15.22
		36	18	14.88	14.83	15.44
		36	39	14.82	14.79	15.29
		75	0	14.65	14.71	15.26
	64QAM	1	0	15.04	14.61	15.06
		1	38	15.26	14.72	15.40
		1	74	14.79	14.79	15.11
		36	0	13.13	14.79	13.65
		36	18	13.53	13.52	13.90
		36	39	13.47	13.49	13.78
		75	0	13.29	13.39	13.79

APPENDIX B - OCCUPIED BANDWIDTH

GSM850					
GSM			EDGE		
CS			8PSK		
Channel	Frequency (MHz)	99% Occupied Bandwidth (MHz)	Channel	Frequency (MHz)	99% Occupied Bandwidth (MHz)
128	824.2	0.2425	128	824.2	0.3116
190	836.6	0.2487	190	836.6	0.3185
251	848.8	0.2445	251	848.8	0.3124
Channel	Frequency (MHz)	26dB Bandwidth (MHz)	Channel	Frequency (MHz)	26dB Bandwidth (MHz)
128	824.2	0.2435	128	824.2	0.3083
190	836.6	0.2437	190	836.6	0.3092
251	848.8	0.2432	251	848.8	0.3150

Spectrum Plot

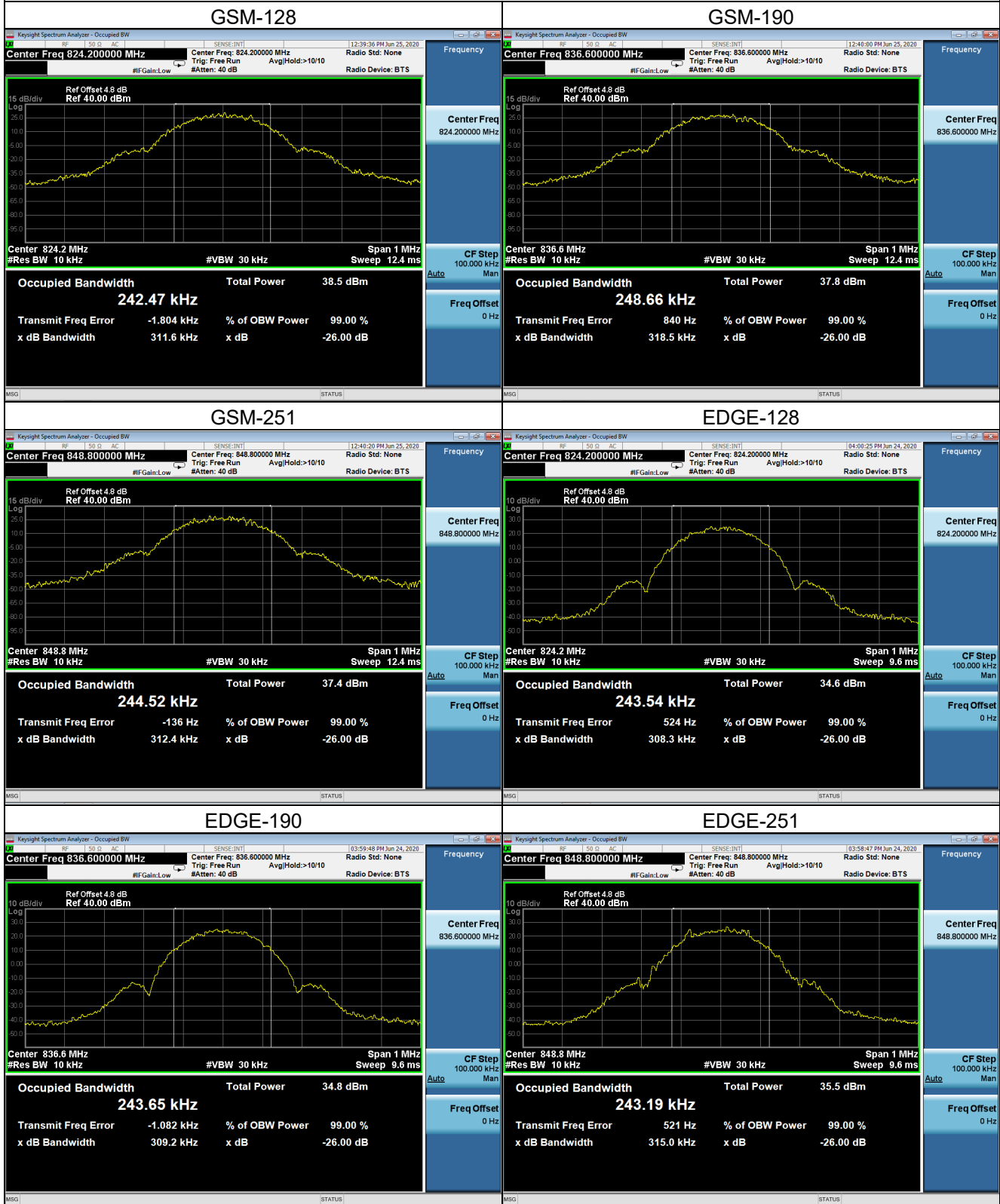

WCDMA Band V_WCDMA					
QPSK					
Channel	Frequency (MHz)	99% Occupied Bandwidth (MHz)	Channel	Frequency (MHz)	26dB Bandwidth (MHz)
4132	826.4	4.1531	4132	826.4	4.730
4182	836.4	4.1395	4182	836.4	4.721
4233	846.6	4.1387	4233	846.6	4.737



WCDMA Band V_HSDPA					
QPSK					
Channel	Frequency (MHz)	99% Occupied Bandwidth (MHz)	Channel	Frequency (MHz)	26dB Bandwidth (MHz)
4132	826.4	4.1468	4132	826.4	4.730
4182	836.4	4.1331	4182	836.4	4.710
4233	846.6	4.1494	4233	846.6	4.708



WCDMA Band V_HSUPA					
QPSK					
Channel	Frequency (MHz)	99% Occupied Bandwidth (MHz)	Channel	Frequency (MHz)	26dB Bandwidth (MHz)
4132	826.4	4.1562	4132	826.4	4.754
4182	836.4	4.1513	4182	836.4	4.737
4233	846.6	4.1495	4233	846.6	4.736



LTE Band 5_1.4M					
QPSK					
Channel	Frequency (MHz)	99% Occupied Bandwidth (MHz)	Channel	Frequency (MHz)	26dB Bandwidth (MHz)
20407	824.7	1.0909	20407	824.7	1.291
20525	836.5	1.1010	20525	836.5	1.288
20643	848.3	1.0873	20643	848.3	1.289
16QAM					
Channel	Frequency (MHz)	99% Occupied Bandwidth (MHz)	Channel	Frequency (MHz)	26dB Bandwidth (MHz)
20407	824.7	1.0910	20407	824.7	1.287
20525	836.5	1.0950	20525	836.5	1.301
20643	848.3	1.0886	20643	848.3	1.289
64QAM					
Channel	Frequency (MHz)	99% Occupied Bandwidth (MHz)	Channel	Frequency (MHz)	26dB Bandwidth (MHz)
20407	824.7	1.0860	20407	824.7	1.285
20525	836.5	1.0884	20525	836.5	1.287
20643	848.3	1.0868	20643	848.3	1.282

Spectrum Plot

QPSK-20407

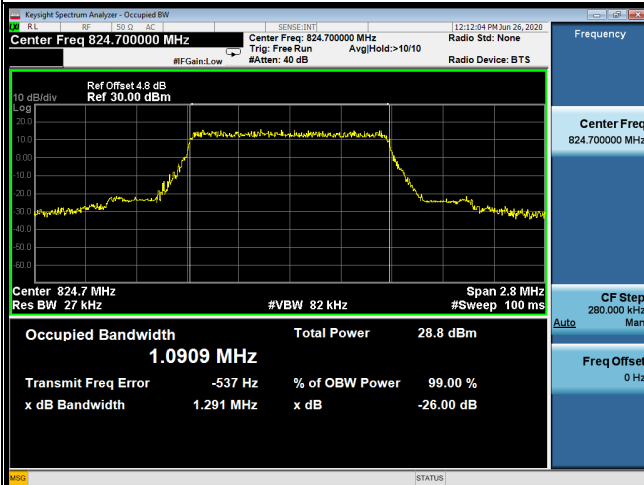

QPSK-20525

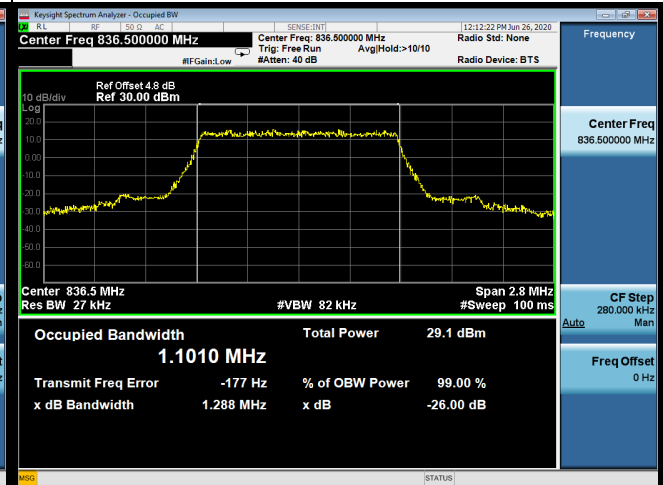

QPSK-20643

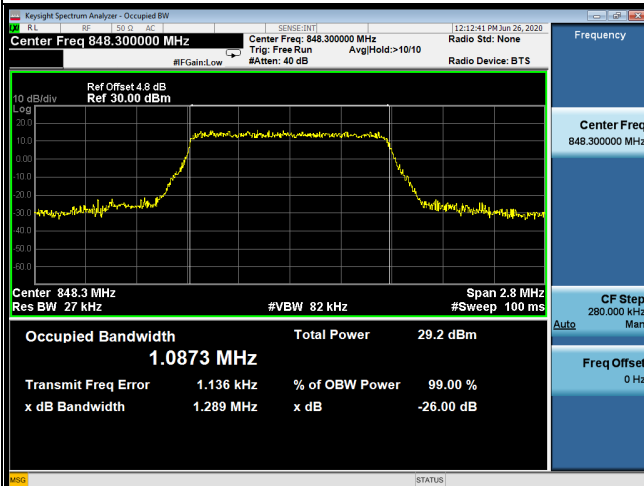

16QAM-20407

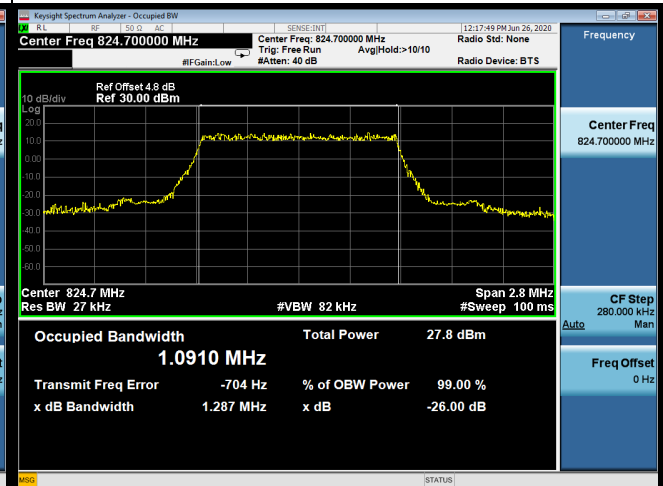

16QAM-20525

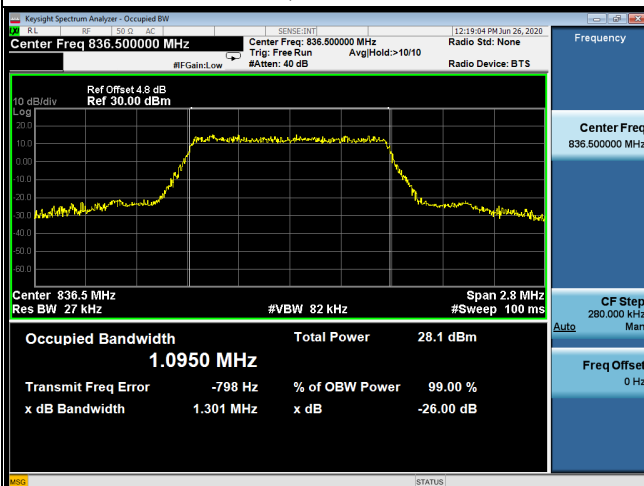

16QAM-20643



Spectrum Plot

64QAM-20407



64QAM-20525

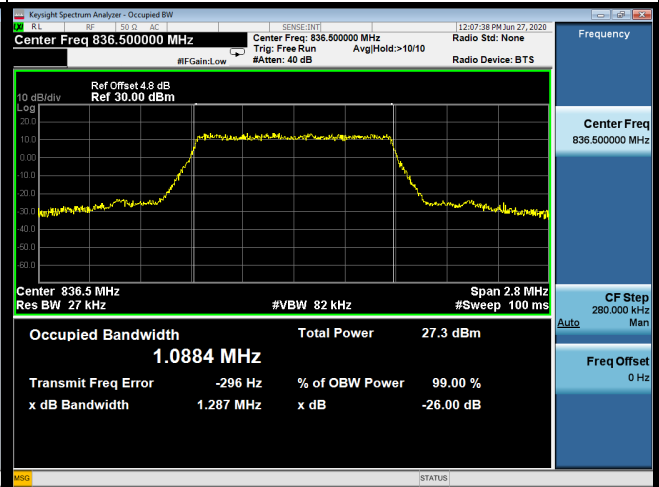

64QAM-20643



-

LTE Band 5_3M					
QPSK					
Channel	Frequency (MHz)	99% Occupied Bandwidth (MHz)	Channel	Frequency (MHz)	26dB Bandwidth (MHz)
20415	825.5	2.7048	20415	825.5	2.999
20525	836.5	2.6997	20525	836.5	2.969
20635	847.5	2.6971	20635	847.5	2.967
16QAM					
Channel	Frequency (MHz)	99% Occupied Bandwidth (MHz)	Channel	Frequency (MHz)	26dB Bandwidth (MHz)
20415	825.5	2.7079	20415	825.5	2.978
20525	836.5	2.6970	20525	836.5	2.986
20635	847.5	2.6964	20635	847.5	2.987
64QAM					
Channel	Frequency (MHz)	99% Occupied Bandwidth (MHz)	Channel	Frequency (MHz)	26dB Bandwidth (MHz)
20415	825.5	2.7060	20415	825.5	2.992
20525	836.5	2.6977	20525	836.5	2.974
20635	847.5	2.7054	20635	847.5	2.993

Spectrum Plot

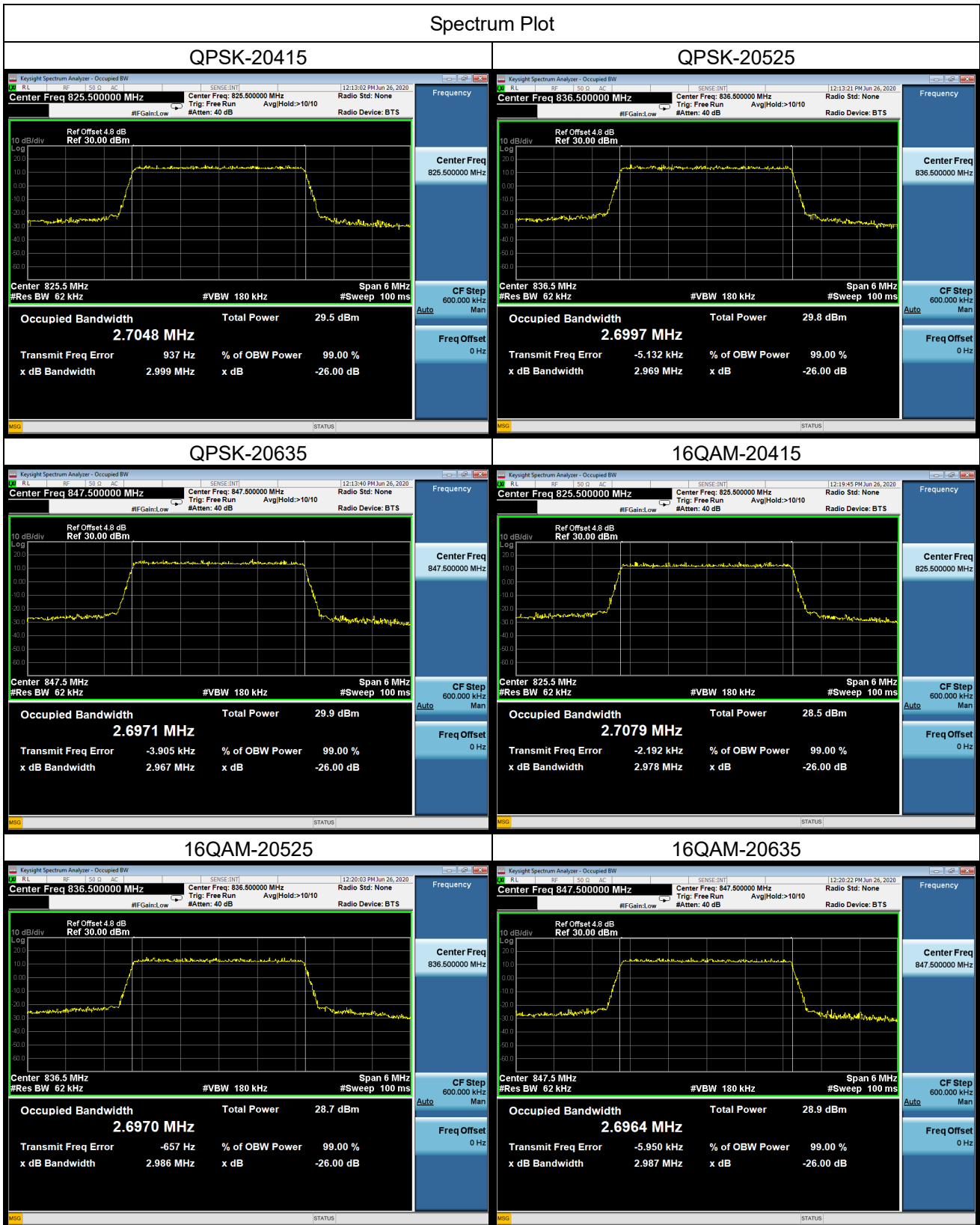

Spectrum Plot

64QAM-20415



64QAM-20525

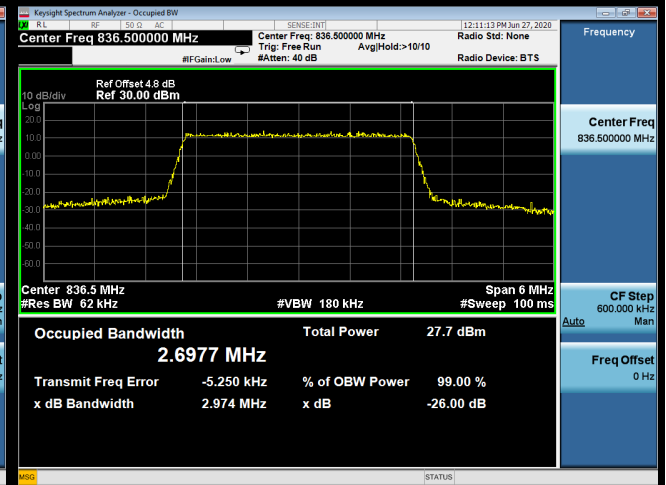

64QAM-20635



LTE Band 5_5M					
QPSK					
Channel	Frequency (MHz)	99% Occupied Bandwidth (MHz)	Channel	Frequency (MHz)	26dB Bandwidth (MHz)
20425	826.5	4.5103	20425	826.5	4.983
20525	836.5	4.5127	20525	836.5	4.955
20625	846.5	4.4986	20625	846.5	4.961
16QAM					
Channel	Frequency (MHz)	99% Occupied Bandwidth (MHz)	Channel	Frequency (MHz)	26dB Bandwidth (MHz)
20425	826.5	4.5028	20425	826.5	5.013
20525	836.5	4.5013	20525	836.5	4.978
20625	846.5	4.4915	20625	846.5	4.953
64QAM					
Channel	Frequency (MHz)	99% Occupied Bandwidth (MHz)	Channel	Frequency (MHz)	26dB Bandwidth (MHz)
20425	826.5	4.5190	20425	826.5	5.006
20525	836.5	4.5113	20525	836.5	4.981
20625	846.5	4.5058	20625	846.5	4.964

Spectrum Plot

QPSK-20425

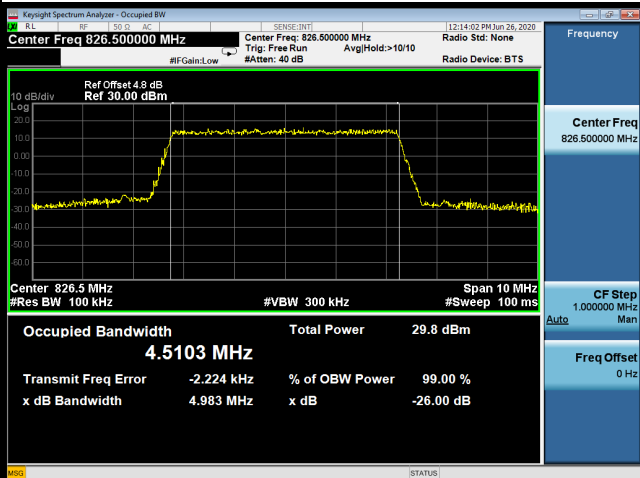

QPSK-20525

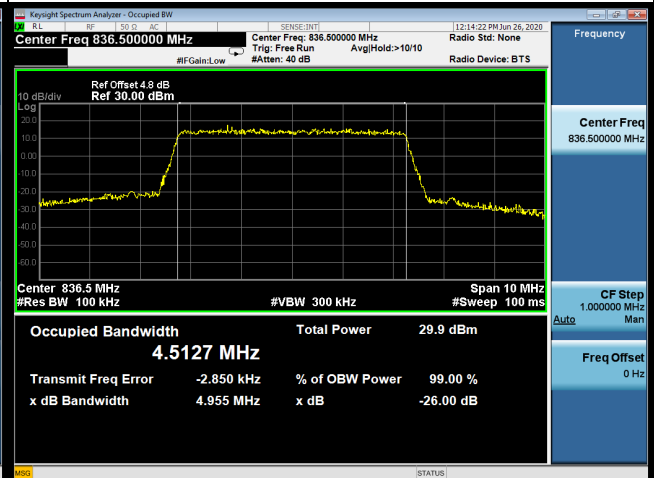

QPSK-20625

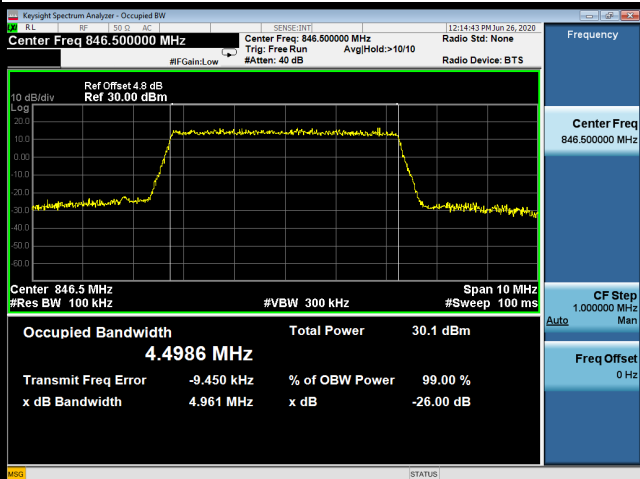

16QAM-20425

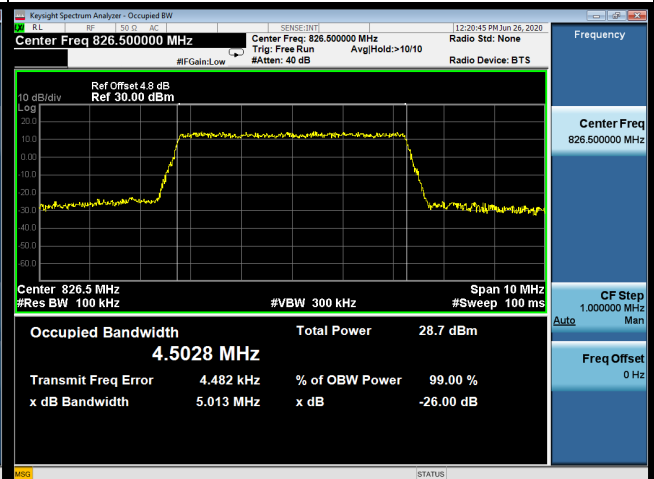

16QAM-20525



16QAM-20625

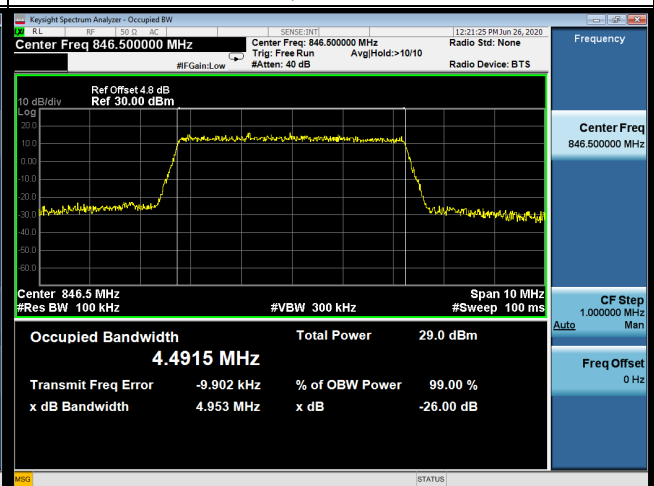

Spectrum Plot

64QAM-20425



64QAM-20525

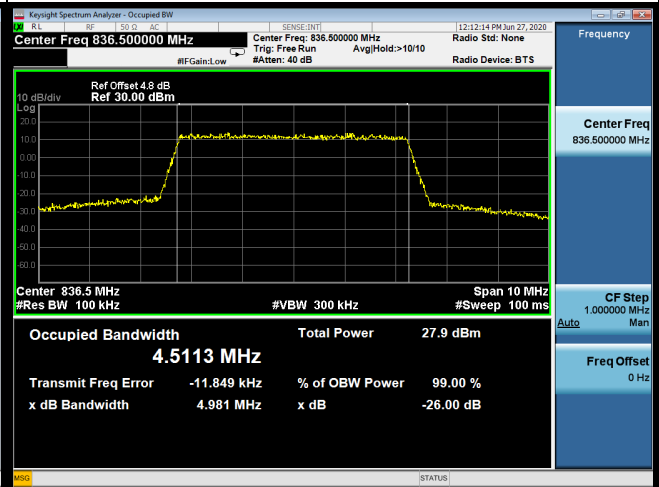

64QAM-20625



LTE Band 5_10M					
QPSK					
Channel	Frequency (MHz)	99% Occupied Bandwidth (MHz)	Channel	Frequency (MHz)	26dB Bandwidth (MHz)
20450	829.0	8.9799	20450	829.0	9.983
20525	836.5	8.9811	20525	836.5	10.03
20600	844.0	8.9684	20600	844.0	9.828
16QAM					
Channel	Frequency (MHz)	99% Occupied Bandwidth (MHz)	Channel	Frequency (MHz)	26dB Bandwidth (MHz)
20450	829.0	8.9700	20450	829.0	9.843
20525	836.5	8.9707	20525	836.5	9.923
20600	844.0	8.9676	20600	844.0	9.903
64QAM					
Channel	Frequency (MHz)	99% Occupied Bandwidth (MHz)	Channel	Frequency (MHz)	26dB Bandwidth (MHz)
20450	829.0	8.9602	20450	829.0	9.837
20525	836.5	8.9719	20525	836.5	9.907
20600	844.0	8.9589	20600	844.0	9.856

Spectrum Plot

QPSK-20450

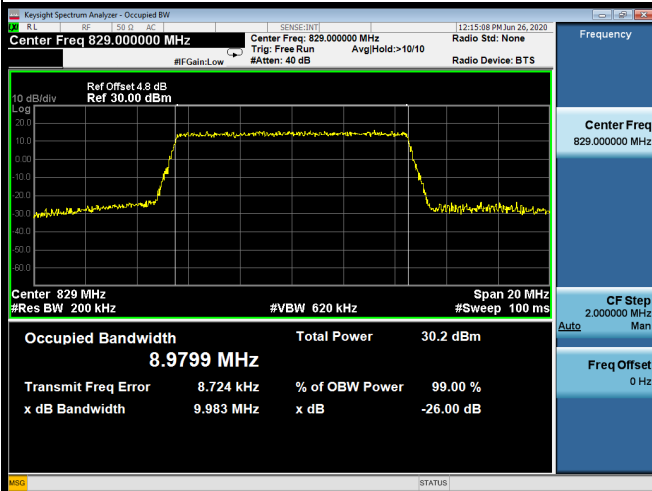

QPSK-20525

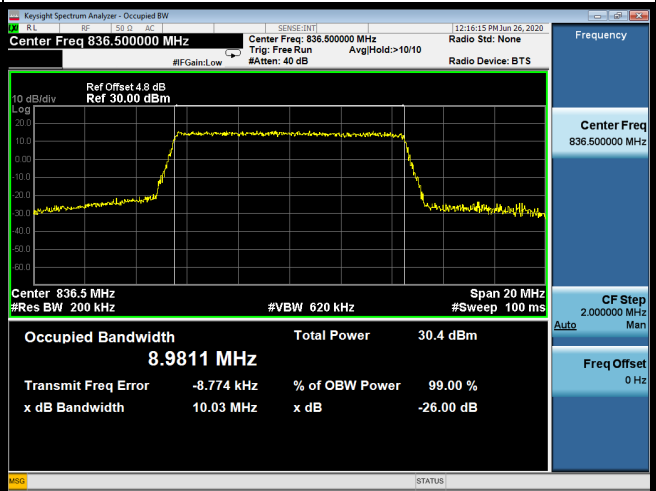

QPSK-20600

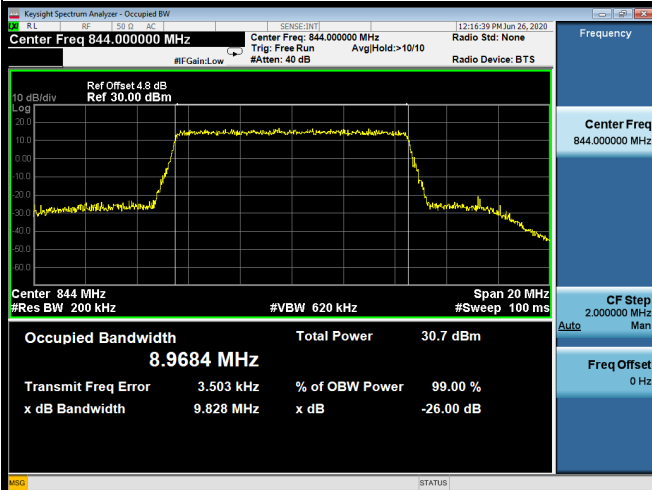

16QAM-20450

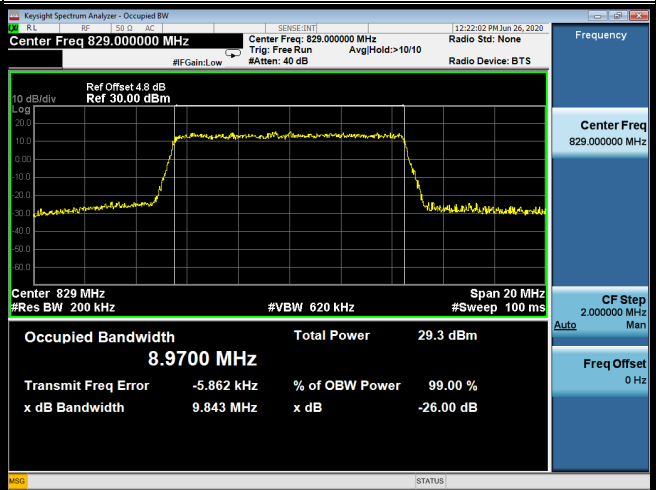

16QAM-20525

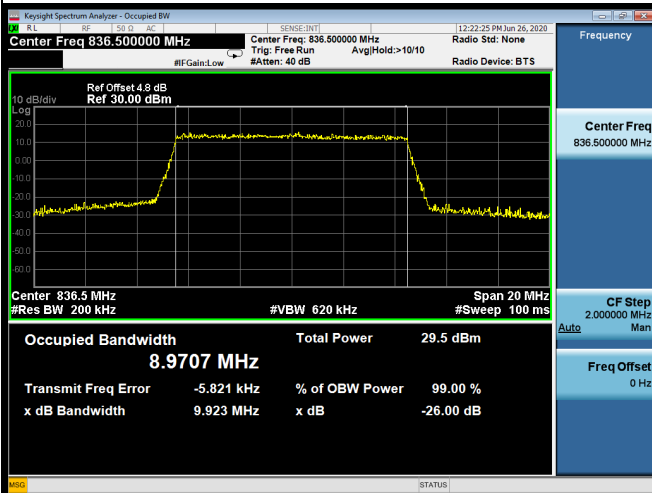

16QAM-20600

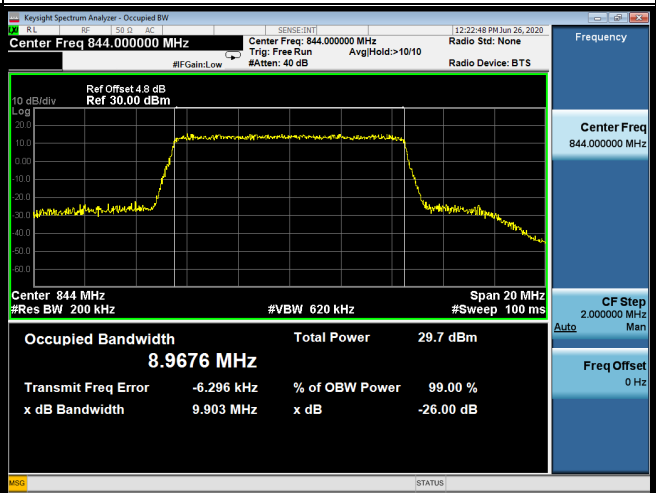

Spectrum Plot

64QAM-20450

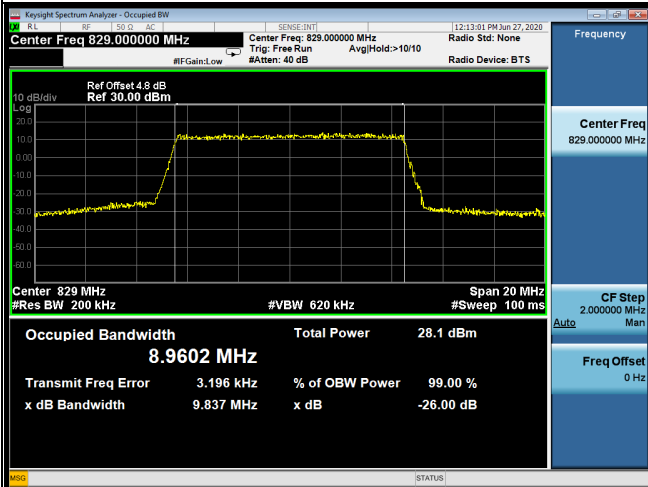

64QAM-20525

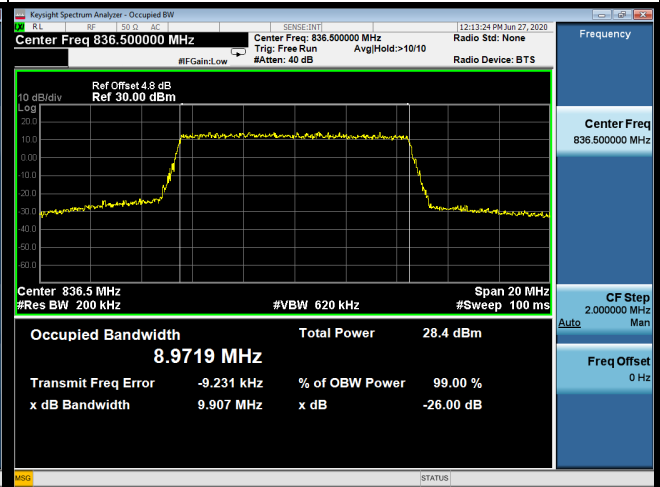

64QAM-20600



LTE Band 26_1.4M					
QPSK					
Channel	Frequency (MHz)	99% Occupied Bandwidth (MHz)	Channel	Frequency (MHz)	26dB Bandwidth (MHz)
26797	824.7	1.0942	26797	824.7	1.301
26915	836.5	1.0998	26915	836.5	1.301
27033	848.3	1.0879	27033	848.3	1.271
16QAM					
Channel	Frequency (MHz)	99% Occupied Bandwidth (MHz)	Channel	Frequency (MHz)	26dB Bandwidth (MHz)
26797	824.7	1.0875	26797	824.7	1.286
26915	836.5	1.0924	26915	836.5	1.288
27033	848.3	1.0940	27033	848.3	1.293
64QAM					
Channel	Frequency (MHz)	99% Occupied Bandwidth (MHz)	Channel	Frequency (MHz)	26dB Bandwidth (MHz)
26797	824.7	1.0902	26797	824.7	1.307
26915	836.5	1.0871	26915	836.5	1.263
27033	848.3	1.0874	27033	848.3	1.263

Spectrum Plot

QPSK-26797



QPSK-26915



QPSK-27033

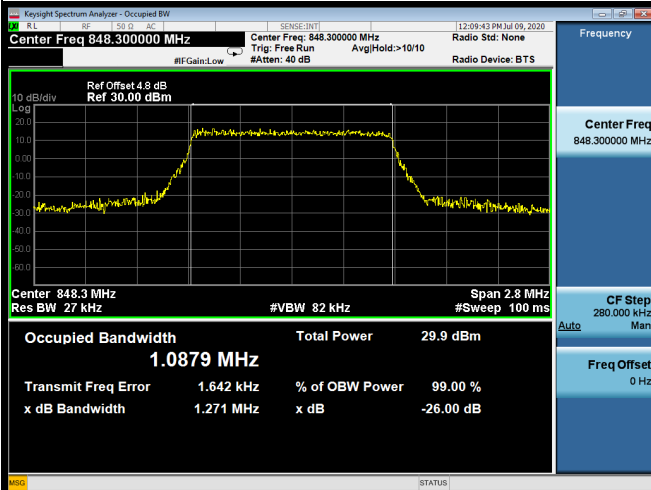

16QAM-26797

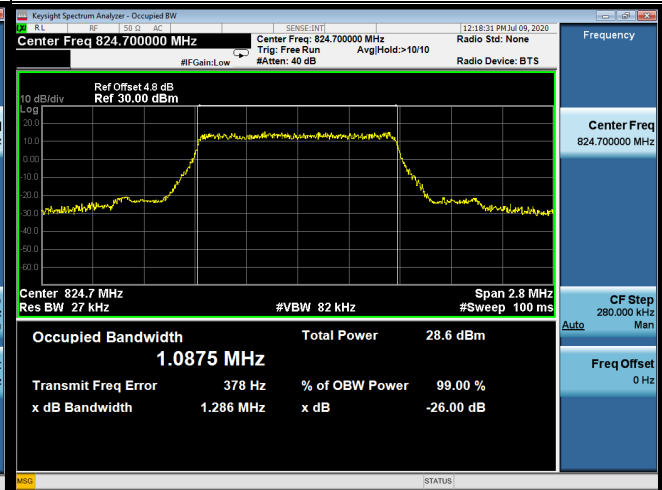

16QAM-26915

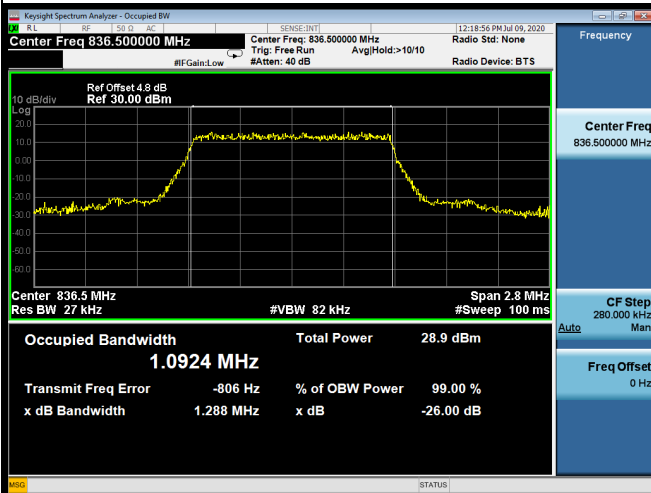

16QAM-27033

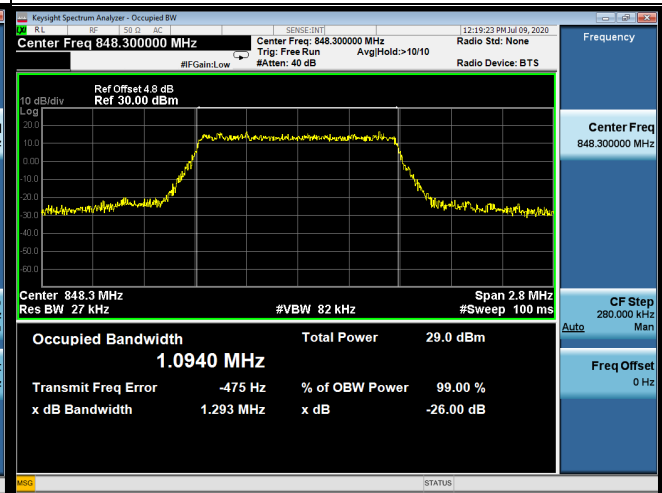

Spectrum Plot

64QAM-26797



64QAM-26915

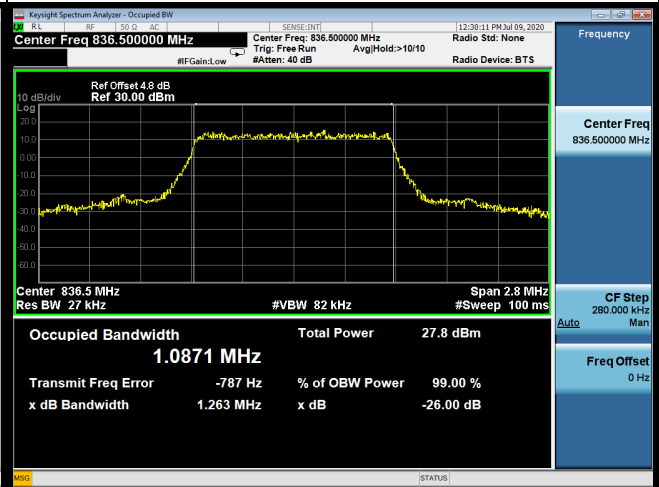

64QAM-27033

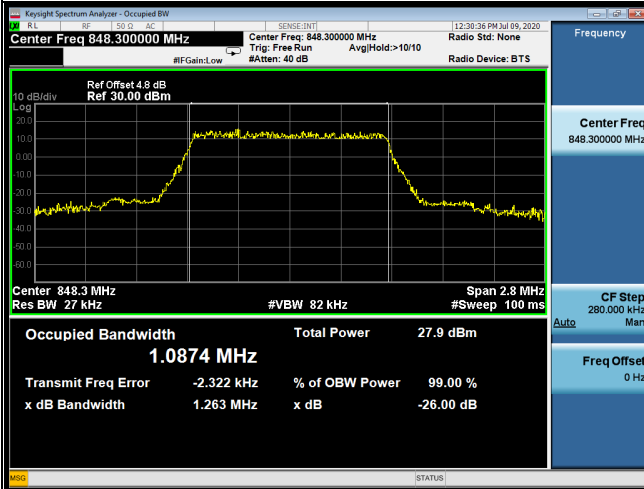

LTE Band 26_3M					
QPSK					
Channel	Frequency (MHz)	99% Occupied Bandwidth (MHz)	Channel	Frequency (MHz)	26dB Bandwidth (MHz)
26805	825.5	2.7017	26805	825.5	2.981
26915	836.5	2.7005	26915	836.5	2.984
27025	847.5	2.6949	27025	847.5	2.984
16QAM					
Channel	Frequency (MHz)	99% Occupied Bandwidth (MHz)	Channel	Frequency (MHz)	26dB Bandwidth (MHz)
26805	825.5	2.7005	26805	825.5	2.976
26915	836.5	2.6951	26915	836.5	2.994
27025	847.5	2.7021	27025	847.5	3.009
64QAM					
Channel	Frequency (MHz)	99% Occupied Bandwidth (MHz)	Channel	Frequency (MHz)	26dB Bandwidth (MHz)
26805	825.5	2.7026	26805	825.5	2.991
26915	836.5	2.7005	26915	836.5	2.960
27025	847.5	2.7005	27025	847.5	2.970

Spectrum Plot

QPSK-26805

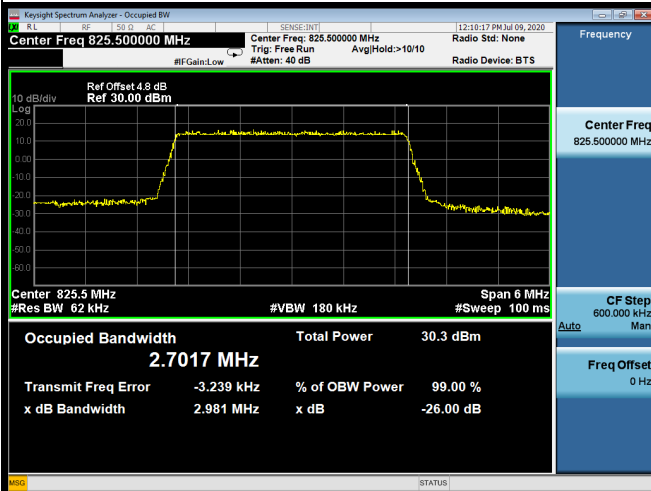

QPSK-26915

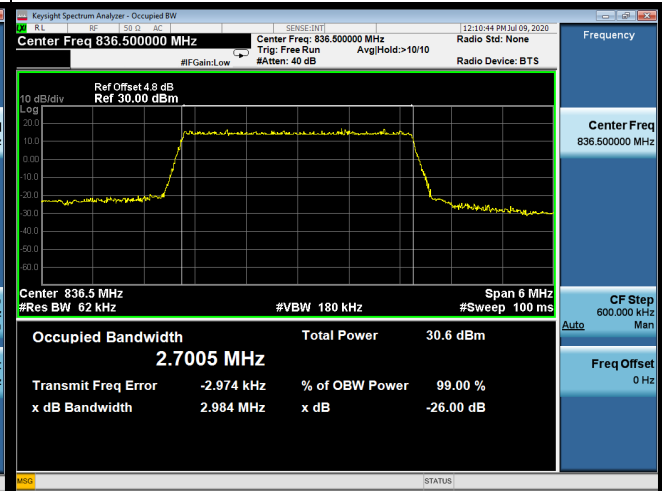

QPSK-27025

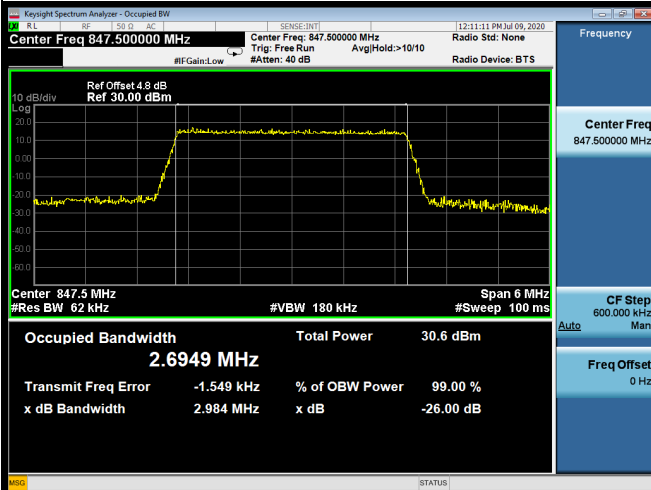

16QAM-26805

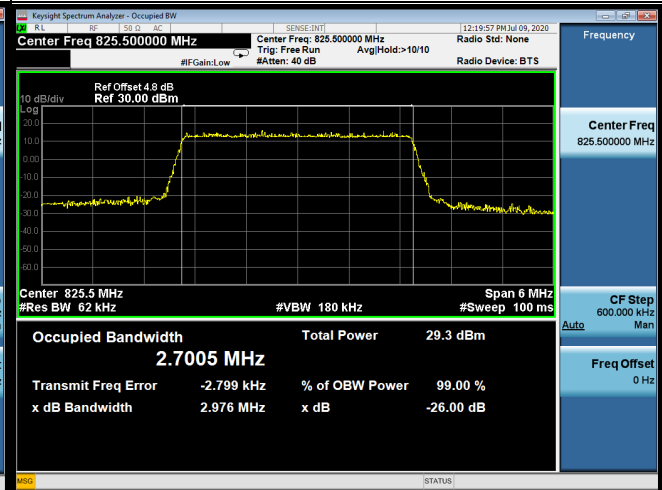

16QAM-26915

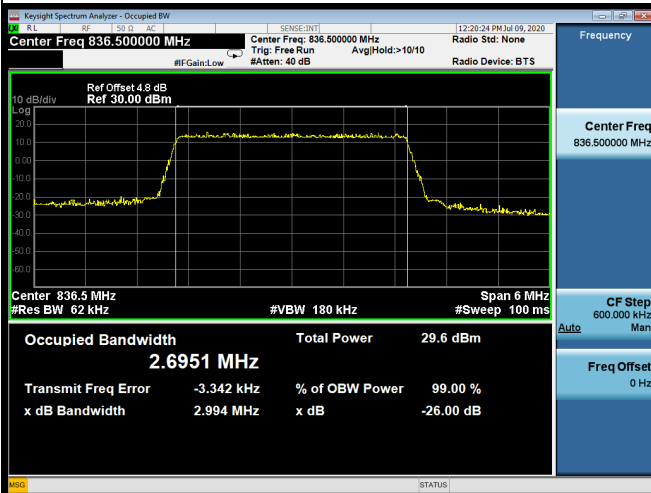

16QAM-27025

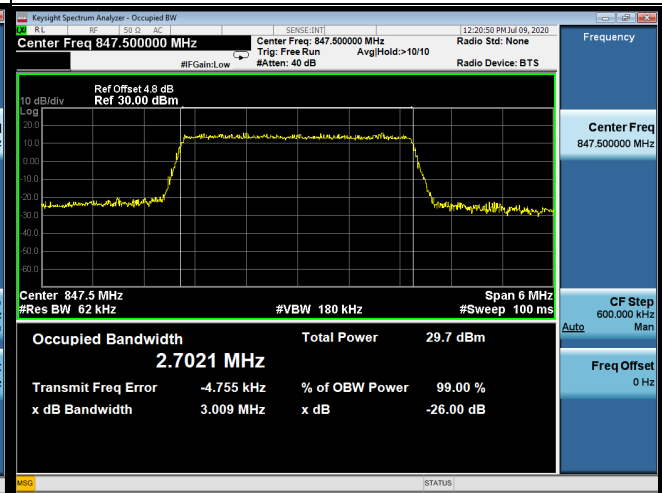

Spectrum Plot

64QAM-26805

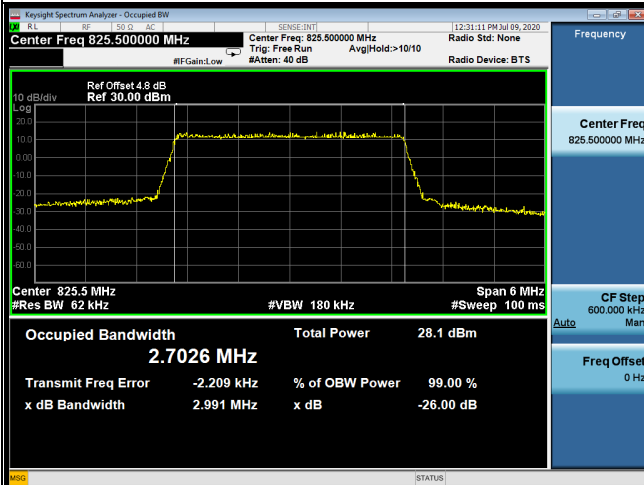

64QAM-26915

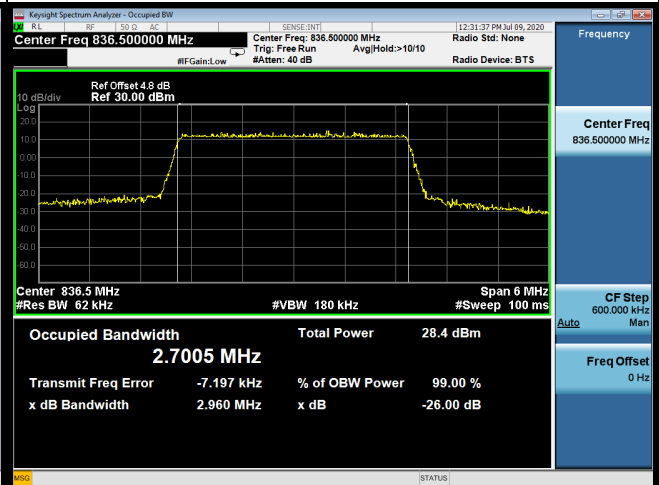

64QAM-27025



LTE Band 26_5M					
QPSK					
Channel	Frequency (MHz)	99% Occupied Bandwidth (MHz)	Channel	Frequency (MHz)	26dB Bandwidth (MHz)
26815	826.5	4.5074	26815	826.5	4.967
26915	836.5	4.5059	26915	836.5	4.960
27015	846.5	4.5050	27015	846.5	5.010
16QAM					
Channel	Frequency (MHz)	99% Occupied Bandwidth (MHz)	Channel	Frequency (MHz)	26dB Bandwidth (MHz)
26815	826.5	4.5068	26815	826.5	4.985
26915	836.5	4.4964	26915	836.5	4.959
27015	846.5	4.4940	27015	846.5	5.018
64QAM					
Channel	Frequency (MHz)	99% Occupied Bandwidth (MHz)	Channel	Frequency (MHz)	26dB Bandwidth (MHz)
26815	826.5	4.5130	26815	826.5	4.995
26915	836.5	4.5083	26915	836.5	4.990
27015	846.5	4.5061	27015	846.5	4.983

Spectrum Plot

QPSK-26815

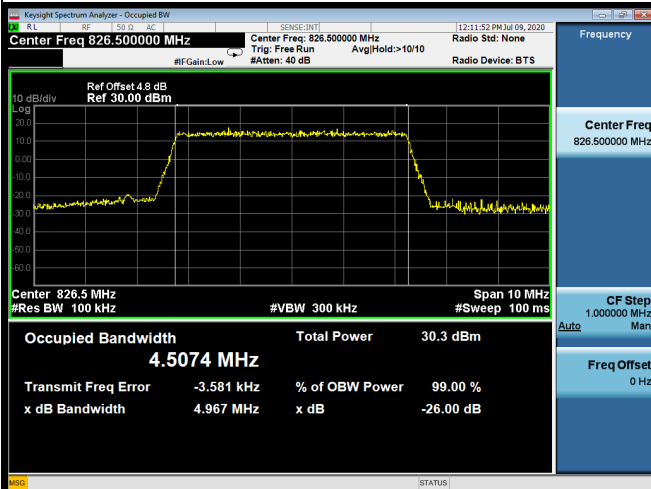

QPSK-26915

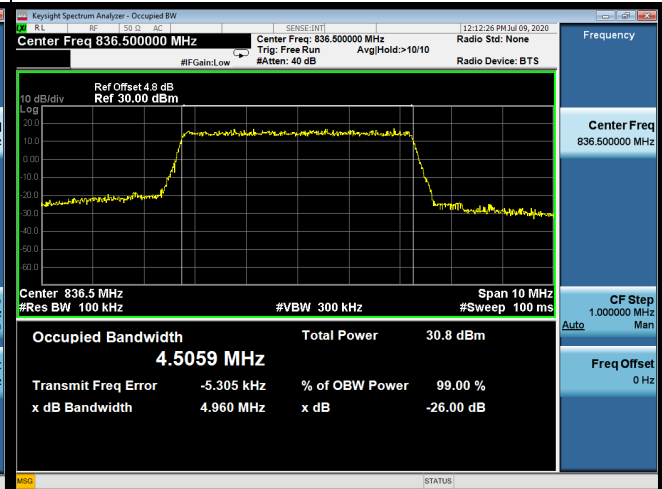

QPSK-27015

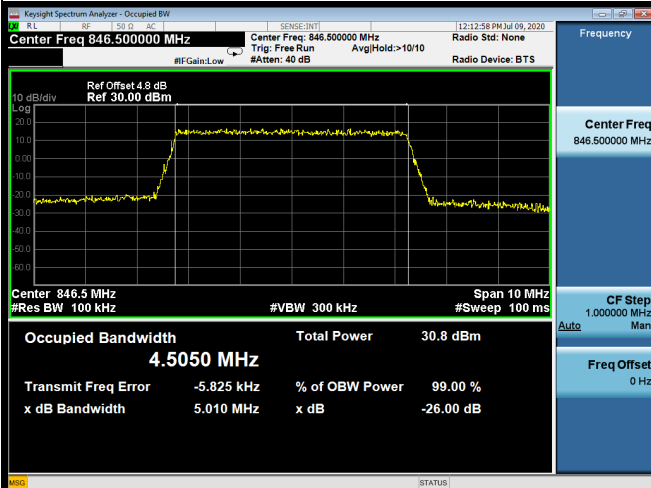

16QAM-26815

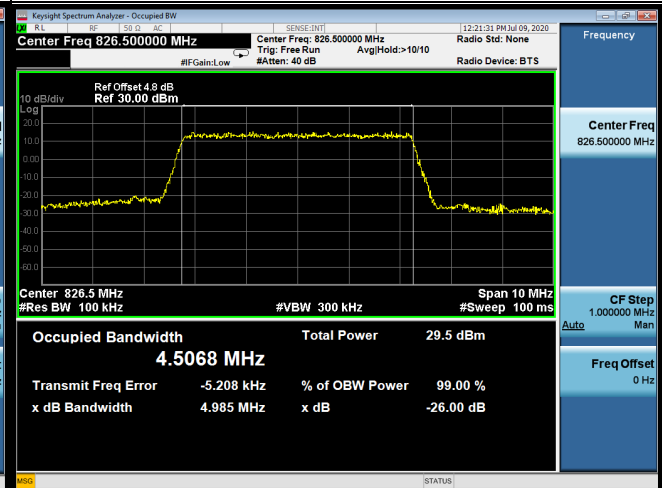

16QAM-26915

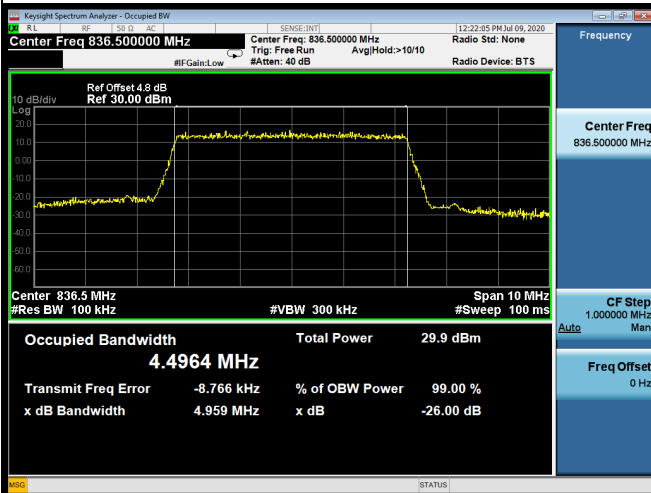

16QAM-27015

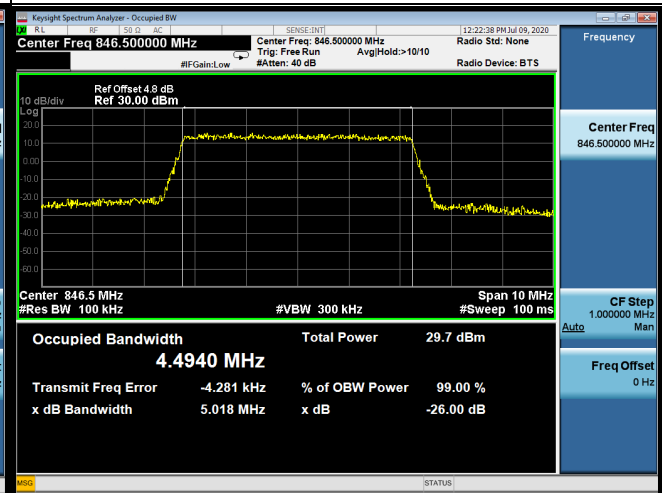

Spectrum Plot

64QAM-26815

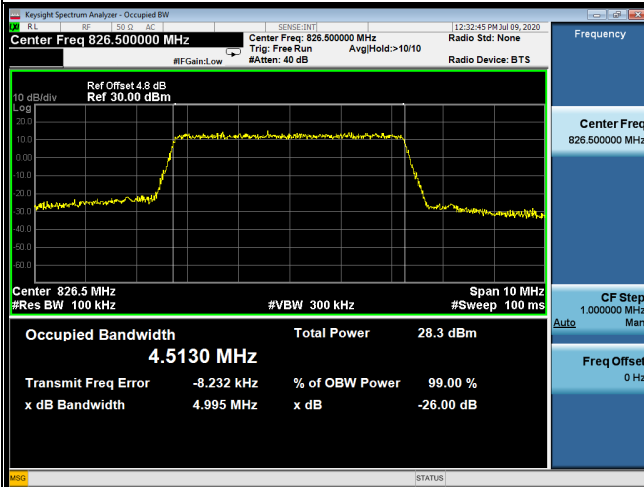

64QAM-26915

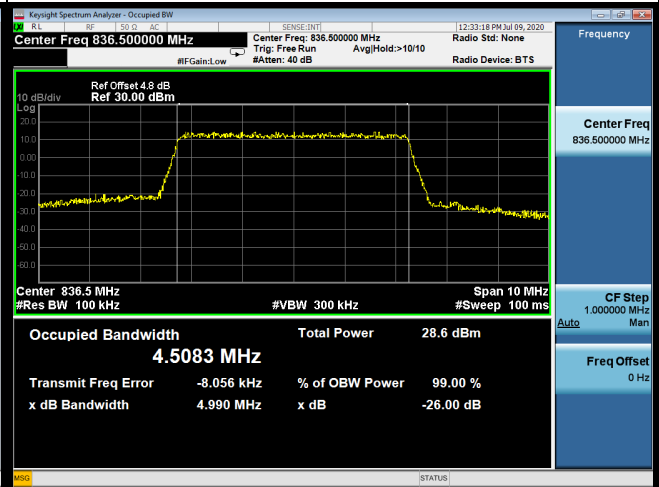

64QAM-27015



LTE Band 26_10M					
QPSK					
Channel	Frequency (MHz)	99% Occupied Bandwidth (MHz)	Channel	Frequency (MHz)	26dB Bandwidth (MHz)
26840	829	8.9650	26840	829	9.919
26915	836.5	8.9813	26915	836.5	9.915
26990	844	8.9639	26990	844	9.985
16QAM					
Channel	Frequency (MHz)	99% Occupied Bandwidth (MHz)	Channel	Frequency (MHz)	26dB Bandwidth (MHz)
26840	829	8.9693	26840	829	9.907
26915	836.5	8.9678	26915	836.5	9.832
26990	844	8.9552	26990	844	9.918
64QAM					
Channel	Frequency (MHz)	99% Occupied Bandwidth (MHz)	Channel	Frequency (MHz)	26dB Bandwidth (MHz)
26840	829	8.9767	26840	829	9.919
26915	836.5	8.9684	26915	836.5	9.843
26990	844	8.9634	26990	844	9.816

Spectrum Plot

QPSK-26840

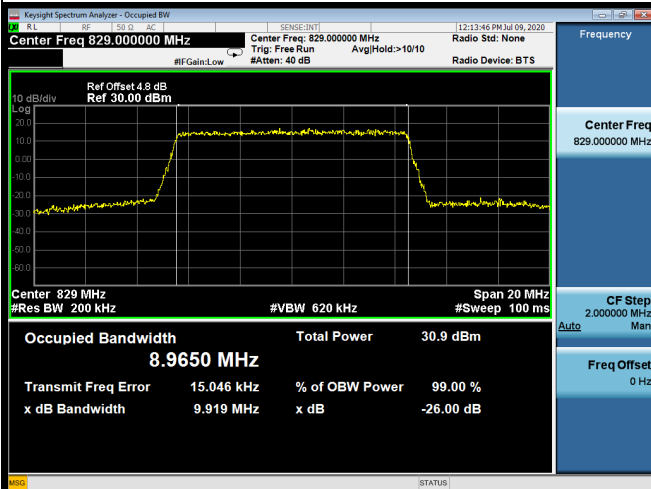

QPSK-26915

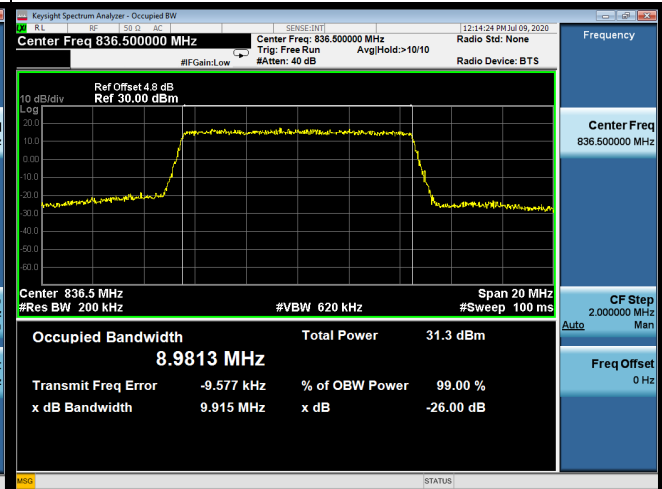

QPSK-26990

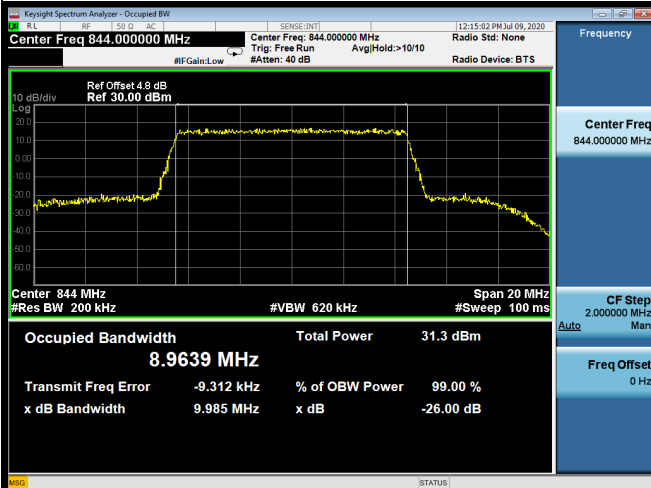

16QAM-26840

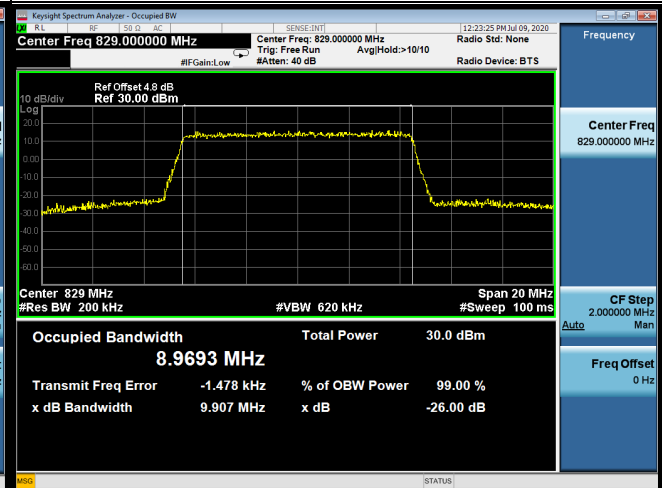

16QAM-26915

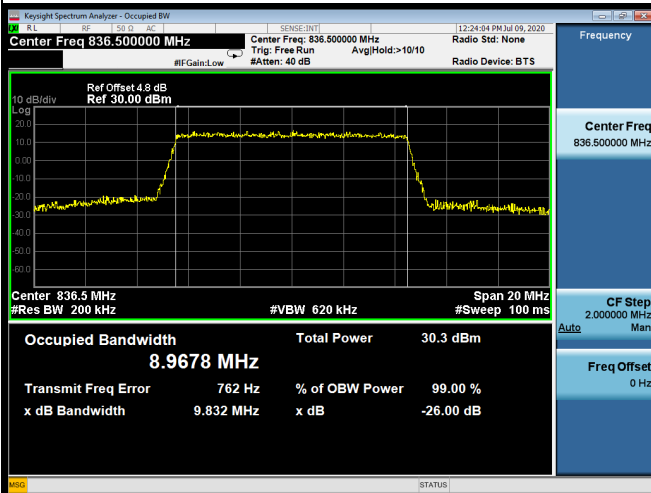

16QAM-26990

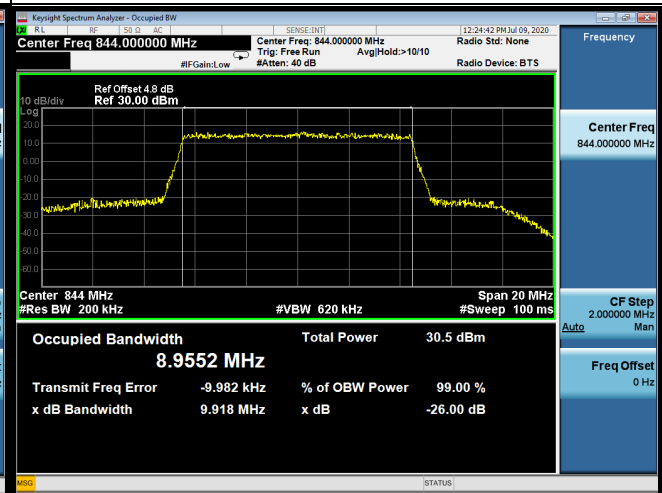

Spectrum Plot

64QAM-26840

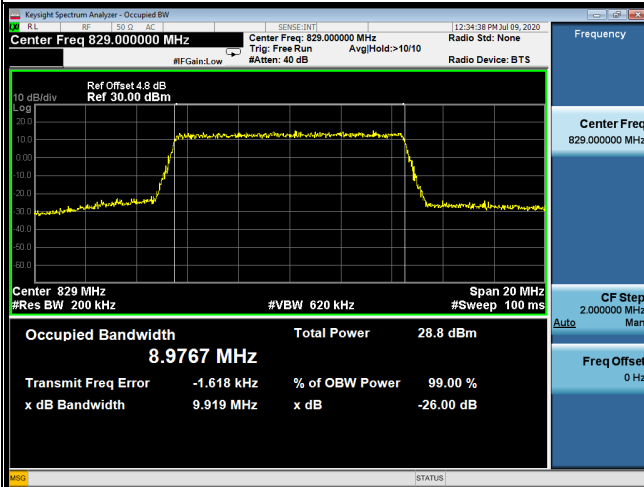

64QAM-26915

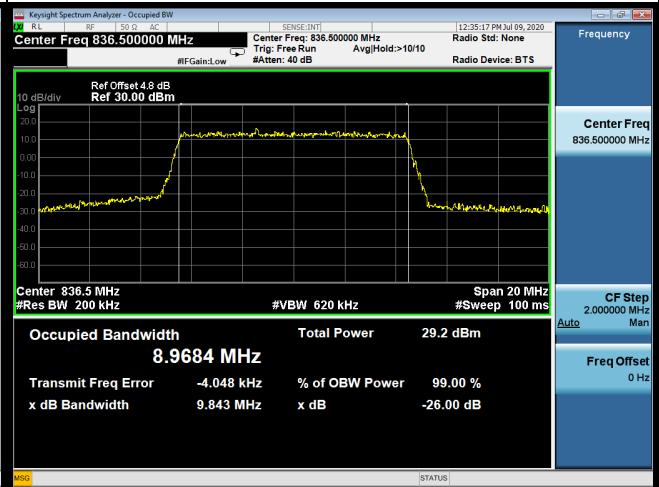

64QAM-26990

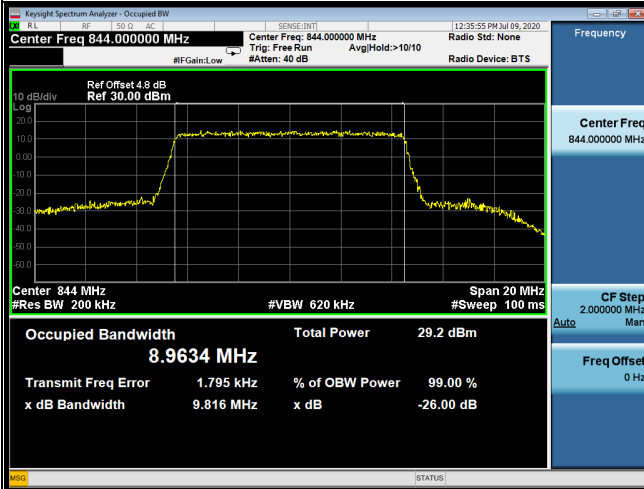

LTE Band 26_15M					
QPSK					
Channel	Frequency (MHz)	99% Occupied Bandwidth (MHz)	Channel	Frequency (MHz)	26dB Bandwidth (MHz)
26865	831.5	13.448	26865	831.5	14.63
26915	836.5	13.453	26915	836.5	14.69
26965	841.5	13.468	26965	841.5	14.73
16QAM					
Channel	Frequency (MHz)	99% Occupied Bandwidth (MHz)	Channel	Frequency (MHz)	26dB Bandwidth (MHz)
26865	831.5	13.427	26865	831.5	14.69
26915	836.5	13.469	26915	836.5	14.62
26965	841.5	13.450	26965	841.5	14.67
64QAM					
Channel	Frequency (MHz)	99% Occupied Bandwidth (MHz)	Channel	Frequency (MHz)	26dB Bandwidth (MHz)
26865	831.5	13.439	26865	831.5	14.68
26915	836.5	13.453	26915	836.5	14.63
26965	841.5	13.435	26965	841.5	14.67

Spectrum Plot

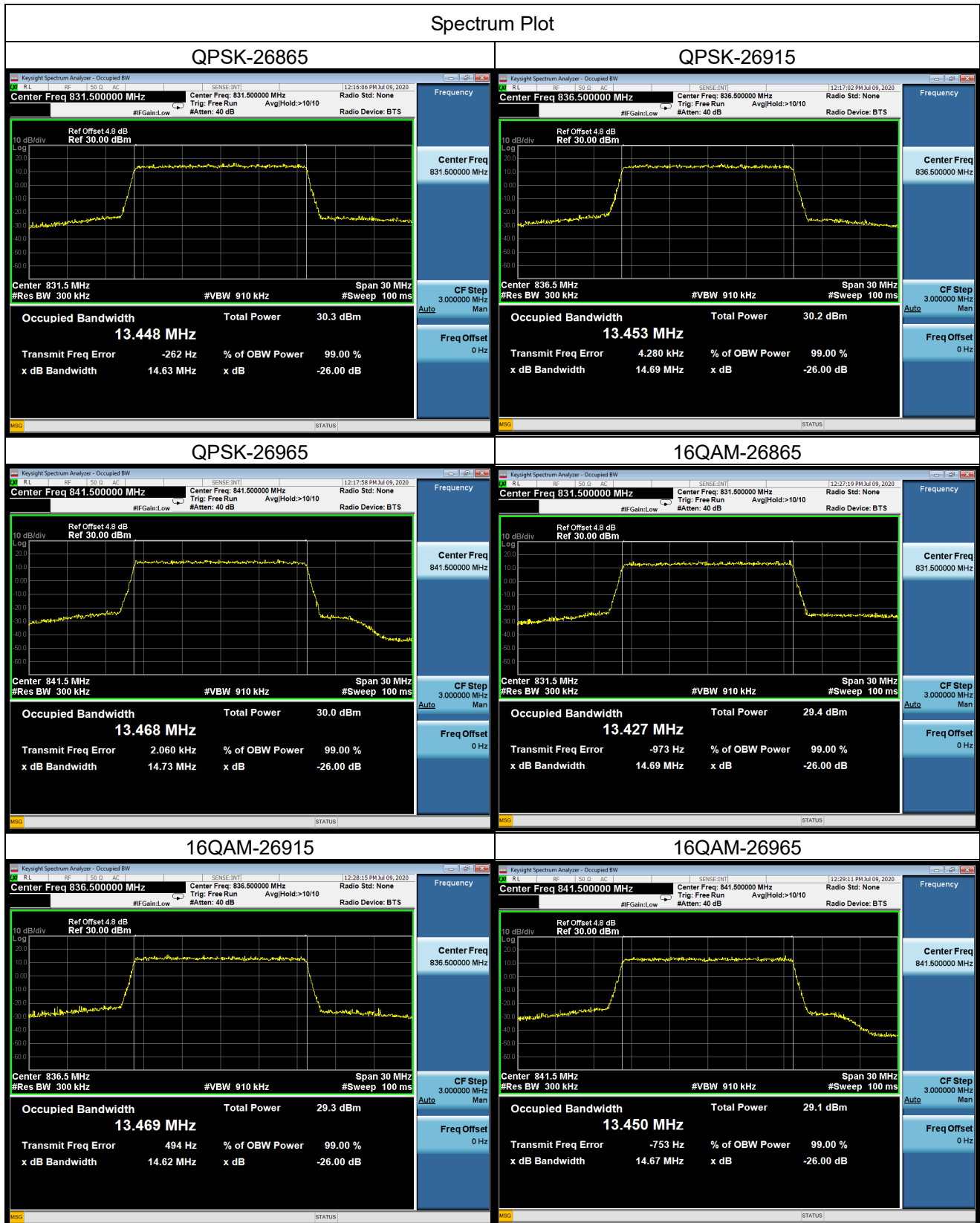

Spectrum Plot

64QAM-26865

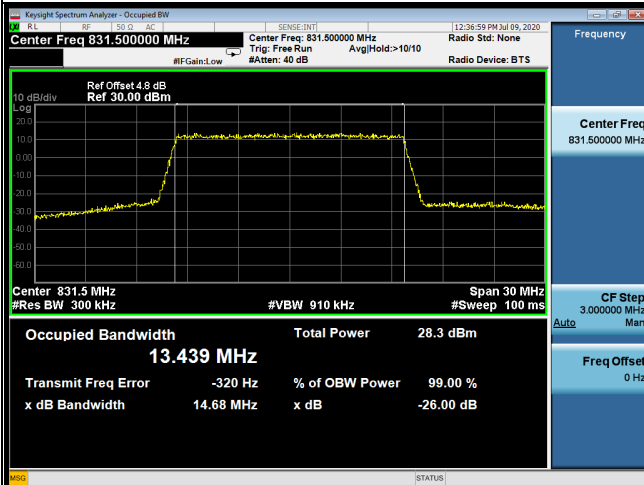

64QAM-26915

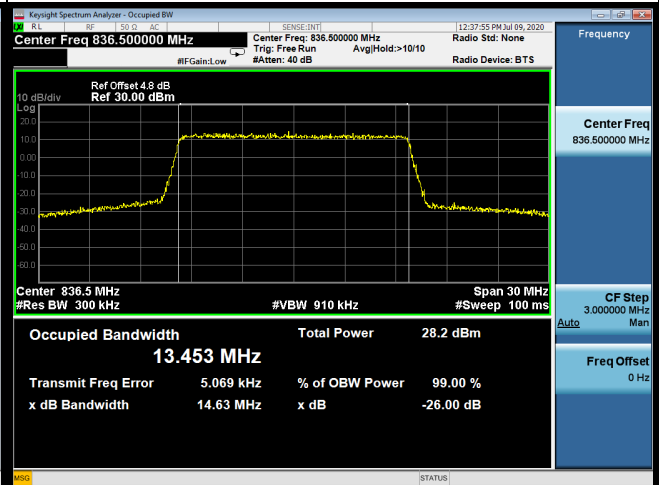

64QAM-26965

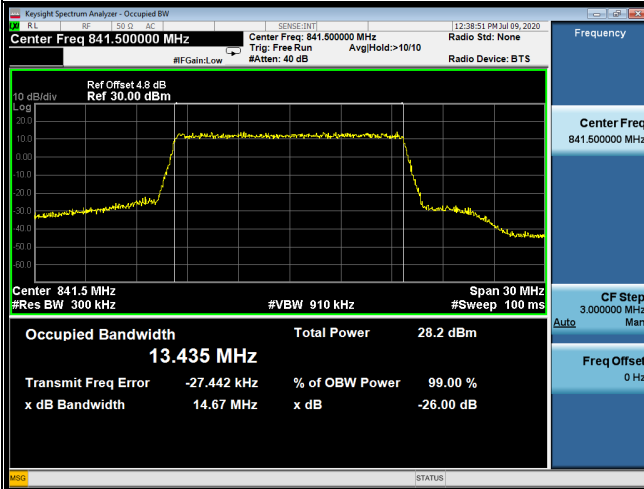

APPENDIX C - CONDUCTED SPURIOUS EMISSIONS

