

# FCC Radio Test Report

## FCC ID: R9C-CPH2083

This report concerns: Original Grant

**Project No.** : 2003C217  
**Equipment** : Mobile Phone  
**Brand Name** : OPPO  
**Test Model** : CPH2083  
**Series Model** : N/A  
**Applicant** : Guangdong OPPO Mobile Telecommunications Corp., Ltd.  
**Address** : NO. 18 HaiBin Road, Wusha village, Chang An Town, DongGuan City, Guangdong, China  
**Manufacturer** : Guangdong OPPO Mobile Telecommunications Corp., Ltd.  
**Address** : NO. 18 HaiBin Road, Wusha village, Chang An Town, DongGuan City, Guangdong, China  
**Factory** : Guangdong OPPO Mobile Telecommunications Corp., Ltd.  
**Address** : NO. 18 HaiBin Road, Wusha village, Chang An Town, DongGuan City, Guangdong, China  
**Date of Receipt** : Mar. 27, 2020  
**Date of Test** : Mar. 28, 2020 ~ Apr. 24, 2020  
**Issued Date** : May 06, 2020  
**Report Version** : R01  
**Test Sample** : Engineering Sample No.: DG2020032771 for conducted, DG2020032773 for radiated.  
**Standard(s)** : FCC Part15, Subpart E(15.407)  
ANSI C63.10-2013  
FCC KDB 789033 D02 General UNII Test Procedures New Rules v02r01  
FCC KDB 662911 D01 Multiple Transmitter Output v02r01

The above equipment has been tested and found compliance with the requirement of the relative standards by BTL Inc.

*Trey Chen*

Prepared by : Trey Chen

*Steven Lu*

Approved by : Steven Lu



Certificate #5123.02

Add: No.3, Jinshagang 1st Road, Shixia, Dalang Town, Dongguan, Guangdong, China.

Tel: +86-769-8318-3000

Web: www.newbtl.com

**Declaration**

**BTL** represents to the client that testing is done in accordance with standard procedures as applicable and that test instruments used has been calibrated with standards traceable to international standard(s) and/or national standard(s).

**BTL's** reports apply only to the specific samples tested under conditions. It is manufacture's responsibility to ensure that additional production units of this model are manufactured with the identical electrical and mechanical components. **BTL** shall have no liability for any declarations, inferences or generalizations drawn by the client or others from **BTL** issued reports.

The report must not be used by the client to claim product certification, approval, or endorsement by NVLAP, NIST, A2LA, or any agency of the U.S. Government.

This report is the confidential property of the client. As a mutual protection to the clients, the public and ourselves, the test report shall not be reproduced, except in full, without our written approval.

**BTL's** laboratory quality assurance procedures are in compliance with the **ISO/IEC 17025** requirements, and accredited by the conformity assessment authorities listed in this test report.

**BTL** is not responsible for the sampling stage, so the results only apply to the sample as received.

The information, data and test plan are provided by manufacturer which may affect the validity of results, so it is manufacturer's responsibility to ensure that the apparatus meets the essential requirements of applied standards and in all the possible configurations as representative of its intended use.

**Limitation**

For the use of the authority's logo is limited unless the Test Standard(s)/Scope(s)/Item(s) mentioned in this test report is (are) included in the conformity assessment authorities acceptance respective.

Please note that the measurement uncertainty is provided for informational purpose only and are not use in determining the Pass/Fail results.

**Table of Contents****Page**

<b>REPORT ISSUED HISTORY</b>	<b>6</b>
<b>1 . SUMMARY OF TEST RESULTS</b>	<b>7</b>
1.1 TEST FACILITY	8
1.2 MEASUREMENT UNCERTAINTY	8
1.3 TEST ENVIRONMENT CONDITIONS	8
<b>2 . GENERAL INFORMATION</b>	<b>9</b>
2.1 GENERAL DESCRIPTION OF EUT	9
2.2 TEST MODES	12
2.3 PARAMETERS OF TEST SOFTWARE	15
2.4 DUTY CYCLE	17
2.5 BLOCK DIAGRAM SHOWING THE CONFIGURATION OF SYSTEM TESTED	19
2.6 SUPPORT UNITS	19
<b>3 . AC POWER LINE CONDUCTED EMISSIONS TEST</b>	<b>20</b>
3.1 LIMIT	20
3.2 TEST PROCEDURE	20
3.3 DEVIATION FROM TEST STANDARD	20
3.4 TEST SETUP	21
3.5 EUT OPERATION CONDITIONS	21
3.6 TEST RESULTS	21
<b>4 . RADIATED EMISSIONS TEST</b>	<b>22</b>
4.1 LIMIT	22
4.2 TEST PROCEDURE	23
4.3 DEVIATION FROM TEST STANDARD	23
4.4 TEST SETUP	24
4.5 EUT OPERATION CONDITIONS	25
4.6 TEST RESULTS - 9 KHZ to 30 MHZ	25
4.7 TEST RESULTS - 30 MHz TO 1000 MHz	25
4.8 TEST RESULTS - ABOVE 1000 MHz	25
<b>5 . BANDWIDTH TEST</b>	<b>26</b>
5.1 LIMIT	26
5.2 TEST PROCEDURE	26
5.3 TEST PROCEDURE	26

<b>Table of Contents</b>	<b>Page</b>
5.4 TEST SETUP	27
5.5 EUT OPERATION CONDITIONS	27
5.6 TEST RESULTS	27
<b>6 . MAXIMUM OUTPUT POWER TEST</b>	<b>28</b>
6.1 LIMIT	28
6.2 TEST PROCEDURE	28
6.3 DEVIATION FROM STANDARD	28
6.4 TEST SETUP	28
6.5 EUT OPERATION CONDITIONS	28
6.6 TEST RESULTS	28
<b>7 . POWER SPECTRAL DENSITY TEST</b>	<b>29</b>
7.1 LIMIT	29
7.2 TEST PROCEDURE	29
7.3 DEVIATION FROM STANDARD	29
7.4 TEST SETUP	29
7.5 EUT OPERATION CONDITIONS	29
7.6 TEST RESULTS	29
<b>8 . FREQUENCY STABILITY MEASUREMENT</b>	<b>30</b>
8.1 LIMIT	30
8.2 TEST PROCEDURE	30
8.3 DEVIATION FROM STANDARD	30
8.4 TEST SETUP	30
8.5 EUT OPERATION CONDITIONS	30
8.6 TEST RESULTS	30
<b>9 . MEASUREMENT INSTRUMENTS LIST</b>	<b>31</b>
<b>APPENDIX A - AC POWER LINE CONDUCTED EMISSIONS</b>	<b>33</b>
<b>APPENDIX B - RADIATED EMISSION - 9 KHZ TO 30 MHZ</b>	<b>36</b>
<b>APPENDIX C - RADIATED EMISSION - 30 MHZ TO 1 GHZ</b>	<b>41</b>
<b>APPENDIX D - RADIATED EMISSION - ABOVE 1000 MHZ</b>	<b>44</b>
<b>APPENDIX E - BANDWIDTH</b>	<b>281</b>
<b>APPENDIX F - MAXIMUM OUTPUT POWER</b>	<b>298</b>
<b>APPENDIX G - POWER SPECTRAL DENSITY</b>	<b>307</b>

**Table of Contents**

**Page**

**APPENDIX H - FREQUENCY STABILITY**

**324**

**REPORT ISSUED HISTORY**

Report Version	Description	Issued Date
R00	Original Issue.	Apr. 29, 2020
R01	Revised the comment.	May 06, 2020

### 1. SUMMARY OF TEST RESULTS

Test procedures according to the technical standard(s):

FCC Part15, Subpart E(15.407)				
Standard(s) Section	Test Item	Test Result	Judgement	Remark
15.207 15.407(b)	AC Power Line Conducted Emissions	APPENDIX A	PASS	-----
15.407(b) 15.205(a) 15.209(a)	Radiated Emissions	APPENDIX B APPENDIX C APPENDIX D	PASS	-----
15.407(a) 15.407(e)	Spectrum Bandwidth	APPENDIX E	PASS	-----
15.407(a)	Maximum Output Power	APPENDIX F	PASS	-----
15.407(a)	Power Spectral Density	APPENDIX G	PASS	-----
15.407(g)	Frequency Stability	APPENDIX H	PASS	-----
15.203	Antenna Requirements	-----	PASS	NOTE (3)
15.407(c)	Automatically Discontinue Transmission	-----	PASS	NOTE (3)

Note:

- (1) "N/A" denotes test is not applicable in this test report.
- (2) The device what use a permanently attached antenna were considered sufficient to comply with the provisions of 15.203.
- (3) During no any information transmission, the EUT can automatically discontinue transmission and become standby mode for power saving. the EUT can detect the controlling signal of ACK message transmitting from remote device and verify whether it shall resend or discontinue transmission.
- (4) For UNII-1 this device was functioned as a  
 Access point device     Client device

### 1.1 TEST FACILITY

The test facilities used to collect the test data in this report is at the location of No.3,Jinshagang 1st Road, Shixia, Dalang Town, Dongguan, Guangdong, China.

BTL's Test Firm Registration Number for FCC: 357015

BTL's Designation Number for FCC: CN1240

### 1.2 MEASUREMENT UNCERTAINTY

ISO/IEC 17025 requires that an estimate of the measurement uncertainties associated with the emissions test results be included in the report. The measurement uncertainties given below are based on a 95% confidence level (based on a coverage factor (k=2))

The BTL measurement uncertainty as below table:

#### A. AC power line conducted emissions test:

Test Site	Method	Measurement Frequency Range	U, (dB)
DG-C02	CISPR	150kHz ~ 30MHz	2.60

#### B. Radiated emissions test:

Test Site	Method	Measurement Frequency Range	Ant. H / V	U, (dB)
DG-CB03	CISPR	9kHz ~ 30MHz	V	3.79
		9kHz ~ 30MHz	H	3.57
		30MHz ~ 200MHz	V	4.88
		30MHz ~ 200MHz	H	4.14
		200MHz ~ 1,000MHz	V	4.62
		200MHz ~ 1,000MHz	H	4.80
		1GHz ~ 6GHz	-	4.58
		6GHz ~ 18GHz	-	5.18
		18GHz ~ 26.5GHz	-	3.62
		26.5GHz ~ 40GHz	-	4.00

Note: Unless specifically mentioned, the uncertainty of measurement has not been taken into account to declare the compliance or non-compliance to the specification.

### 1.3 TEST ENVIRONMENT CONDITIONS

Test Item	Temperature	Humidity	Test Voltage	Tested By
AC Power Line Conducted Emissions	25°C	55%	AC 120V/60Hz	Damon Deng
Radiated Emissions-9K-30MHz	25°C	60%	AC 120V/60Hz	Sheldon Ou
Radiated Emissions-30 MHz to 1GHz	24°C	68%	AC 120V/60Hz	Sheldon Ou
Radiated Emissions-Above 1000 MHz	24°C	68%	AC 120V/60Hz	Sheldon Ou
Spectrum Bandwidth	23.1°C	45%	DC 3.85V	Hayden Chen
Maximum Output Power	23.1°C	45%	DC 3.85V	Hayden Chen
Power Spectral Density	23.1°C	45%	DC 3.85V	Hayden Chen
Frequency Stability	Normal & Extreme	45%	Normal & Extreme	Hayden Chen



## 2. GENERAL INFORMATION

### 2.1 GENERAL DESCRIPTION OF EUT

Equipment	Mobile Phone
Brand Name	OPPO
Test Model	CPH2083
Series Model	N/A
Model Difference(s)	N/A
Hardware Version	11
Software Version	ColorOS V6.1.2
Power Source	1. DC Voltage supplied from AC/DC adapter. 1# Model: OP52KAUH 2# Model: OP52JAUH 3# Model: OP52YAUH 2. Supplied from Li-ion Polymer battery. Model: BLP673 3. Supplied from USB port.
Power Rating	1. I/P:100-240V~ 50/60Hz 0.4A O/P:5V --- 2A 2. 3.85Vdc, 4100mAh/15.78Wh 3. DC 5V
Operation Frequency	UNII-1: 5150 MHz~5250 MHz UNII-2A: 5250 MHz~5350 MHz UNII-2C: 5470 MHz~5725 MHz UNII-3: 5725 MHz~5850 MHz
Modulation Type	OFDM
Bit Rate of Transmitter	Up to 433.3Mbps Mbps
Maximum Output Power for UNII-1	IEEE 802.11a: 18.33 dBm (0.0681 W) IEEE 802.11n (HT20): 18.27 dBm (0.0671 W) IEEE 802.11n (HT40): 16.95 dBm (0.0495 W) IEEE 802.11ac (VHT20): 18.00 dBm (0.0631 W) IEEE 802.11ac (VHT40): 17.16 dBm (0.0520 W) IEEE 802.11ac (VHT80): 13.30 dBm (0.0214 W)
Maximum Output Power for UNII-2A	IEEE 802.11a: 18.47 dBm (0.0703 W) IEEE 802.11n (HT20): 18.34 dBm (0.0682 W) IEEE 802.11n (HT40): 17.15 dBm (0.0519 W) IEEE 802.11ac (VHT20): 18.38 dBm (0.0689 W) IEEE 802.11ac (VHT40): 17.21 dBm (0.0526 W) IEEE 802.11ac (VHT80): 12.10 dBm (0.0162 W)
Maximum Output Power for UNII-2C	IEEE 802.11a: 17.90 dBm (0.0617 W) IEEE 802.11n (HT20): 17.79 dBm (0.0601 W) IEEE 802.11n (HT40): 16.42 dBm (0.0439 W) IEEE 802.11ac (VHT20): 17.89 dBm (0.0615 W) IEEE 802.11ac (VHT40): 16.75 dBm (0.0473 W) IEEE 802.11ac (VHT80): 15.74 dBm (0.0375 W)
Maximum Output Power for UNII-3	IEEE 802.11a: 18.14 dBm (0.0652 W) IEEE 802.11n (HT20): 17.97 dBm (0.0627 W) IEEE 802.11n (HT40): 14.70 dBm (0.0295 W) IEEE 802.11ac (VHT20): 18.07 dBm (0.0641 W) IEEE 802.11ac (VHT40): 14.88 dBm (0.0308 W) IEEE 802.11ac (VHT80): 16.81 dBm (0.0480 W)

Note:

1. For a more detailed features description, please refer to the manufacturer's specifications or the user's manual.

## 2. Channel List:

IEEE 802.11a IEEE 802.11n (HT20) IEEE 802.11ac (VHT20)		IEEE 802.11n (HT40) IEEE 802.11ac (VHT40)		IEEE 802.11ac (VHT80)	
UNII-1		UNII-1		UNII-1	
Channel	Frequency (MHz)	Channel	Frequency (MHz)	Channel	Frequency (MHz)
36	5180	38	5190	42	5210
40	5200	46	5230		
44	5220				
48	5240				

IEEE 802.11a IEEE 802.11n (HT20) IEEE 802.11ac (VHT20)		IEEE 802.11n (HT40) IEEE 802.11ac (VHT40)		IEEE 802.11ac (VHT80)	
UNII-2A		UNII-2A		UNII-2A	
Channel	Frequency (MHz)	Channel	Frequency (MHz)	Channel	Frequency (MHz)
52	5260	54	5270	58	5290
56	5280	62	5310		
60	5300				
64	5320				

IEEE 802.11a IEEE 802.11n (HT20) IEEE 802.11ac (VHT20)		IEEE 802.11n (HT40) IEEE 802.11ac (VHT40)		IEEE 802.11ac (VHT80)	
UNII-2C		UNII-2C		UNII-2C	
Channel	Frequency (MHz)	Channel	Frequency (MHz)	Channel	Frequency (MHz)
100	5500	102	5510	106	5530
104	5520	110	5550	122	5610
108	5540	118	5590		
112	5560	126	5630		
116	5580	134	5670		
120	5600				
124	5620				
128	5640				
4.45	5660				
136	5680				
140	5700				

IEEE 802.11a IEEE 802.11n (HT20) IEEE 802.11ac (VHT20)		IEEE 802.11n (HT40) IEEE 802.11ac (VHT40)		IEEE 802.11ac (VHT80)	
UNII-3		UNII-3		UNII-3	
Channel	Frequency (MHz)	Channel	Frequency (MHz)	Channel	Frequency (MHz)
149	5745	151	5755	155	5775
153	5765	159	5795		
157	5785				
161	5805				
165	5825				

## 3. Table for Filed Antenna:

Ant.	Brand	Model Name	Antenna Type	Connector	Gain (dBi)
1	N/A	N/A	Internal	N/A	-3

## 2.2 TEST MODES

The test system was pre-tested based on the consideration of all possible combinations of EUT operation mode.

Pretest Mode	Description
Mode 1	TX A Mode / CH36, CH40, CH48 (UNII-1)
Mode 2	TX N (HT20) Mode / CH36, CH40, CH48 (UNII-1)
Mode 3	TX N (HT40) Mode / CH38, CH46 (UNII-1)
Mode 4	TX AC (VHT20) Mode / CH36, CH40, CH48 (UNII-1)
Mode 5	TX AC (VHT40) Mode / CH38, CH46 (UNII-1)
Mode 6	TX AC (VHT80) Mode / CH42 (UNII-1)
Mode 7	TX A Mode / CH52, CH60, CH64 (UNII-2A)
Mode 8	TX N (HT20) Mode / CH52, CH60, CH64 (UNII-2A)
Mode 9	TX N (HT40) Mode / CH54, CH62 (UNII-2A)
Mode 10	TX AC (VHT20) Mode / CH52, CH60, CH64 (UNII-2A)
Mode 11	TX AC (VHT40) Mode / CH54, CH62 (UNII-2A)
Mode 12	TX AC (VHT80) Mode / CH58 (UNII-2A)
Mode 13	TX A Mode / CH100, CH116, CH140 (UNII-2C)
Mode 14	TX N (HT20) Mode / CH100, CH116, CH140 (UNII-2C)
Mode 15	TX N (HT40) Mode / CH102, CH110, CH134 (UNII-2C)
Mode 16	TX AC (VHT20) Mode / CH100, CH116, CH140 (UNII-2C)
Mode 17	TX AC (VHT40) Mode / CH102, CH110, CH134 (UNII-2C)
Mode 18	TX AC (VHT80) Mode / CH106, CH122 (UNII-2C)
Mode 19	TX A Mode / CH149,CH157,CH165 (UNII-3)
Mode 20	TX N (HT20) Mode / CH149,CH157,CH165 (UNII-3)
Mode 21	TX N (HT40) Mode / CH151,CH159 (UNII-3)
Mode 22	TX AC (VHT20) Mode / CH149,CH157,CH165 (UNII-3)
Mode 23	TX AC (VHT40) Mode / CH151,CH159 (UNII-3)
Mode 24	TX AC (VHT80) Mode / CH155 (UNII-3)
Mode 25	TX A Mode / CH60 (UNII-2A)

Following mode(s) was (were) found to be the worst case(s) and selected for the final test.

AC power line conducted emissions test	
Final Test Mode	Description
Mode 25	TX A Mode / CH60 (UNII-2A)

Radiated emissions test – Below 1GHz	
Final Test Mode	Description
Mode 25	TX A Mode / CH60 (UNII-2A)

Radiated emissions test	
Final Test Mode	Description
Mode 1	TX A Mode / CH36, CH40, CH48 (UNII-1)
Mode 2	TX N (HT20) Mode / CH36, CH40, CH48 (UNII-1)
Mode 3	TX N (HT40) Mode / CH38, CH46 (UNII-1)
Mode 4	TX AC (VHT20) Mode / CH36, CH40, CH48 (UNII-1)
Mode 5	TX AC (VHT40) Mode / CH38, CH46 (UNII-1)
Mode 6	TX AC (VHT80) Mode / CH42 (UNII-1)
Mode 7	TX A Mode / CH52, CH60, CH64 (UNII-2A)
Mode 8	TX N (HT20) Mode / CH52, CH60, CH64 (UNII-2A)
Mode 9	TX N (HT40) Mode / CH54, CH62 (UNII-2A)
Mode 10	TX AC (VHT20) Mode / CH52, CH60, CH64 (UNII-2A)
Mode 11	TX AC (VHT40) Mode / CH54, CH62 (UNII-2A)
Mode 12	TX AC (VHT80) Mode / CH58 (UNII-2A)
Mode 13	TX A Mode / CH100, CH116, CH140 (UNII-2C)
Mode 14	TX N (HT20) Mode / CH100, CH116, CH140 (UNII-2C)
Mode 15	TX N (HT40) Mode / CH102, CH110, CH134 (UNII-2C)
Mode 16	TX AC (VHT20) Mode / CH100, CH116, CH140 (UNII-2C)
Mode 17	TX AC (VHT40) Mode / CH102, CH110, CH134 (UNII-2C)
Mode 18	TX AC (VHT80) Mode / CH106, CH122 (UNII-2C)
Mode 19	TX A Mode / CH149,CH157,CH165 (UNII-3)
Mode 20	TX N (HT20) Mode / CH149,CH157,CH165 (UNII-3)
Mode 21	TX N (HT40) Mode / CH151,CH159 (UNII-3)
Mode 22	TX AC (VHT20) Mode / CH149,CH157,CH165 (UNII-3)
Mode 23	TX AC (VHT40) Mode / CH151,CH159 (UNII-3)
Mode 24	TX AC (VHT80) Mode / CH155 (UNII-3)

Conducted test	
Final Test Mode	Description
Mode 1	TX A Mode / CH36, CH40, CH48 (UNII-1)
Mode 2	TX N (HT20) Mode / CH36, CH40, CH48 (UNII-1)
Mode 3	TX N (HT40) Mode / CH38, CH46 (UNII-1)
Mode 4	TX AC (VHT20) Mode / CH36, CH40, CH48 (UNII-1)
Mode 5	TX AC (VHT40) Mode / CH38, CH46 (UNII-1)
Mode 6	TX AC (VHT80) Mode / CH42 (UNII-1)
Mode 7	TX A Mode / CH52, CH60, CH64 (UNII-2A)
Mode 8	TX N (HT20) Mode / CH52, CH60, CH64 (UNII-2A)
Mode 9	TX N (HT40) Mode / CH54, CH62 (UNII-2A)
Mode 10	TX AC (VHT20) Mode / CH52, CH60, CH64 (UNII-2A)
Mode 11	TX AC (VHT40) Mode / CH54, CH62 (UNII-2A)
Mode 12	TX AC (VHT80) Mode / CH58 (UNII-2A)
Mode 13	TX A Mode / CH100, CH116, CH140 (UNII-2C)
Mode 14	TX N (HT20) Mode / CH100, CH116, CH140 (UNII-2C)
Mode 15	TX N (HT40) Mode / CH102, CH110, CH134 (UNII-2C)
Mode 16	TX AC (VHT20) Mode / CH100, CH116, CH140 (UNII-2C)
Mode 17	TX AC (VHT40) Mode / CH102, CH110, CH134 (UNII-2C)
Mode 18	TX AC (VHT80) Mode / CH106, CH122 (UNII-2C)
Mode 19	TX A Mode / CH149,CH157,CH165 (UNII-3)
Mode 20	TX N (HT20) Mode / CH149,CH157,CH165 (UNII-3)
Mode 21	TX N (HT40) Mode / CH151,CH159 (UNII-3)
Mode 22	TX AC (VHT20) Mode / CH149,CH157,CH165 (UNII-3)
Mode 23	TX AC (VHT40) Mode / CH151,CH159 (UNII-3)
Mode 24	TX AC (VHT80) Mode / CH155 (UNII-3)

Note:

- (1) For radiated emission above 1 GHz test, 1GHz~26.5GHz and 26.5GHz~40GHz have been pre-tested and in this report only recorded the worst case. The remaining spurious points are all below the limit value of 20dB.
- (2) For radiated spurious emissions below 1 GHz test, all adapters had been pre-tested and the IEEE 802.11n20 channel 06 was found to be the worst case and recorded.

### 2.3 PARAMETERS OF TEST SOFTWARE

UNII-1			
Test Software	***3646633***		
Test Frequency (MHz)	5180	5200	5240
IEEE 802.11a	15	18	18
IEEE 802.11n (HT20)	15	18	18
Test Frequency (MHz)	5190	5230	
IEEE 802.11n (HT40)	14	17	

UNII-2A			
Test Software	***3646633***		
Test Frequency (MHz)	5260	5300	5320
IEEE 802.11a	18	18	15
IEEE 802.11n (HT20)	18	18	15
Test Frequency (MHz)	5270	5310	
IEEE 802.11n (HT40)	17	13	

UNII-2C			
Test Software	***3646633***		
Test Frequency (MHz)	5500	5580	5700
IEEE 802.11a	15	18	15
IEEE 802.11n (HT20)	15	18	14
Test Frequency (MHz)	5510	5550	5670
IEEE 802.11n (HT40)	12	17	15

UNII-3			
Test Software	***3646633***		
Test Frequency (MHz)	5745	5785	5825
IEEE 802.11a	15	18	15
IEEE 802.11n (HT20)	13	18	15
Test Frequency (MHz)	5755	5795	
IEEE 802.11n (HT40)	13	15	

UNII-1			
Test Software	***3646633***		
Test Frequency (MHz)	5180	5200	5240
IEEE 802.11ac (VHT20)	15	18	18
Test Frequency (MHz)	5190	5230	
IEEE 802.11ac (VHT40)	14.5	17	
Test Frequency (MHz)	5210		
IEEE 802.11ac (VHT80)	13		

UNII-2A			
Test Software	***3646633***		
Test Frequency (MHz)	5260	5300	5320
IEEE 802.11ac (VHT20)	18	18	15
Test Frequency (MHz)	5270	5310	
IEEE 802.11ac (VHT40)	17	14	
Test Frequency (MHz)	5290		
IEEE 802.11ac (VHT80)	12		

UNII-2C			
Test Software	***3646633***		
Test Frequency (MHz)	5500	5580	5700
IEEE 802.11ac (VHT20)	14.5	18	14
Test Frequency (MHz)	5510	5550	5670
IEEE 802.11ac (VHT40)	14	17	15
Test Frequency (MHz)	5530	5610	
IEEE 802.11ac (VHT80)	12	16	

UNII-3			
Test Software	***3646633***		
Test Frequency (MHz)	5745	5785	5825
IEEE 802.11ac (VHT20)	15	18	15
Test Frequency (MHz)	5755	5795	
IEEE 802.11ac (VHT40)	15	15	
Test Frequency (MHz)	5775		
IEEE 802.11ac (VHT80)	17		



## 2.4 DUTY CYCLE

If duty cycle is  $\geq 98\%$ , duty factor is not required.  
 If duty cycle is  $< 98\%$ , duty factor shall be considered.  
 The output power = measured power + duty factor.

**IEEE 802.11a**

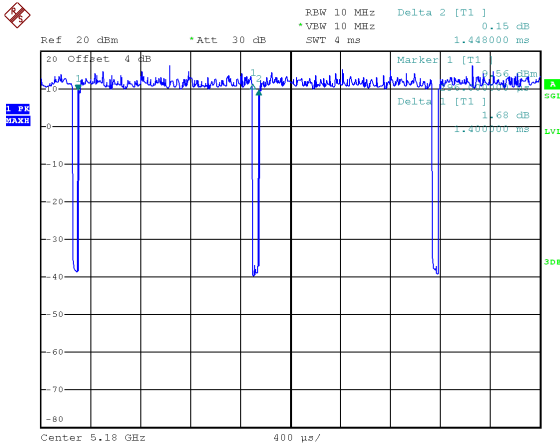

Date: 31.MAR.2020 19:19:12

Duty cycle =  $1.400 \text{ ms} / 1.448 \text{ ms} = 96.69\%$   
 Duty Factor =  $10 * \log(1 / \text{Duty cycle}) = 0.15$

**IEEE 802.11n (HT40)**

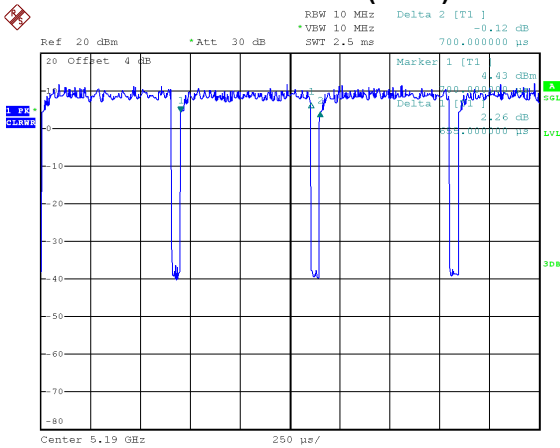

Date: 31.MAR.2020 19:23:15

Duty cycle =  $0.655 \text{ ms} / 0.700 \text{ ms} = 93.57\%$   
 Duty Factor =  $10 * \log(1 / \text{Duty cycle}) = 0.29$

**IEEE 802.11n (HT20)**

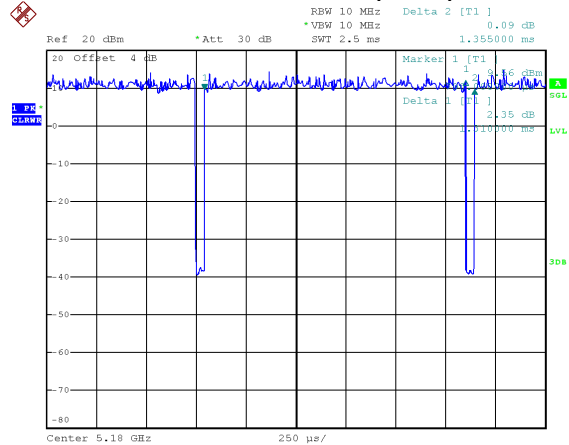

Date: 31.MAR.2020 19:19:28

Duty cycle =  $1.310 \text{ ms} / 1.355 \text{ ms} = 96.68\%$   
 Duty Factor =  $10 * \log(1 / \text{Duty cycle}) = 0.15$

**IEEE 802.11ac (VHT20)**

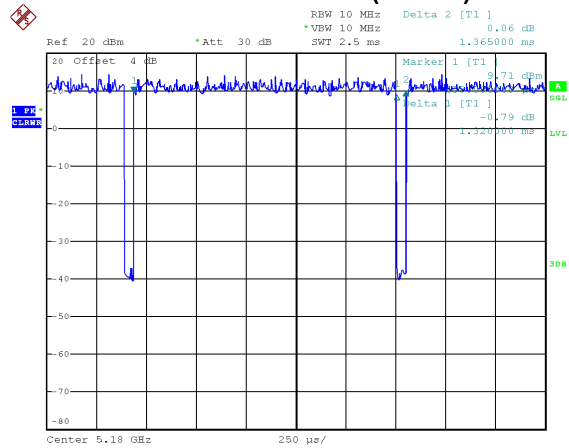

Date: 31.MAR.2020 19:19:56

Duty cycle =  $1.320 \text{ ms} / 1.365 \text{ ms} = 96.70\%$   
 Duty Factor =  $10 * \log(1 / \text{Duty cycle}) = 0.15$

### IEEE 802.11ac (VHT40)

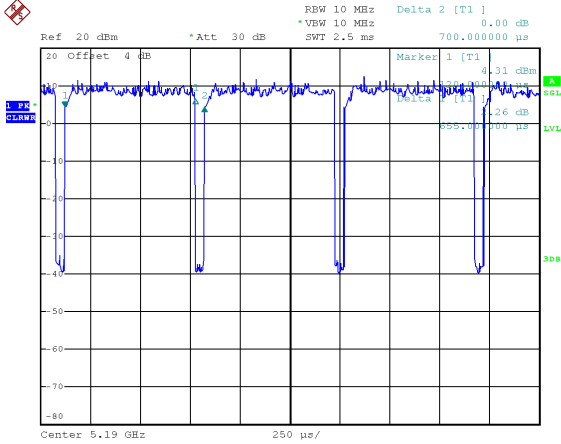

Date: 31.MAR.2020 19:23:35

Duty cycle = 0.655 ms / 0.700 ms = 93.57%  
 Duty Factor =  $10 * \log(1 / \text{Duty cycle}) = 0.29$

### IEEE 802.11ac (VHT80)

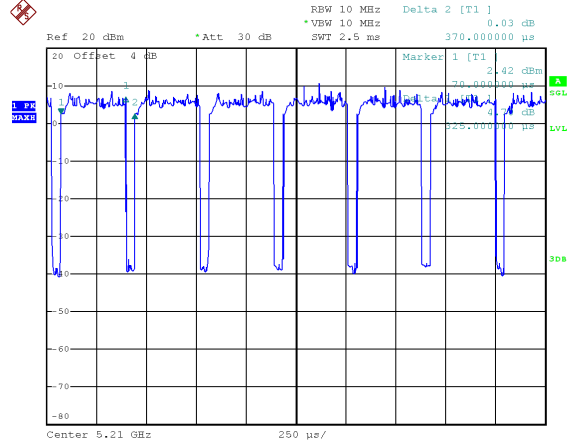

Date: 31.MAR.2020 19:23:57

Duty cycle = 0.325 ms / 0.370 ms = 87.84%  
 Duty Factor =  $10 * \log(1 / \text{Duty cycle}) = 0.56$

**NOTE:**

For IEEE 802.11a, IEEE 802.11n (HT20) and IEEE 802.11ac (VHT20):

For radiated emissions frequency above 1 GHz, the resolution bandwidth of test receiver/spectrum analyzer is 1 MHz and the video bandwidth is 1 kHz (Duty cycle < 98%).

For IEEE 802.11n (HT40) and IEEE 802.11ac (VHT40):

For radiated emissions frequency above 1 GHz, the resolution bandwidth of test receiver/spectrum analyzer is 1 MHz and the video bandwidth is 2 kHz (Duty cycle < 98%).

For IEEE 802.11ac (VHT80):

For radiated emissions frequency above 1 GHz, the resolution bandwidth of test receiver/spectrum analyzer is 1 MHz and the video bandwidth is 3 kHz (Duty cycle < 98%).

**2.5 BLOCK DIAGRAM SHOWING THE CONFIGURATION OF SYSTEM TESTED**

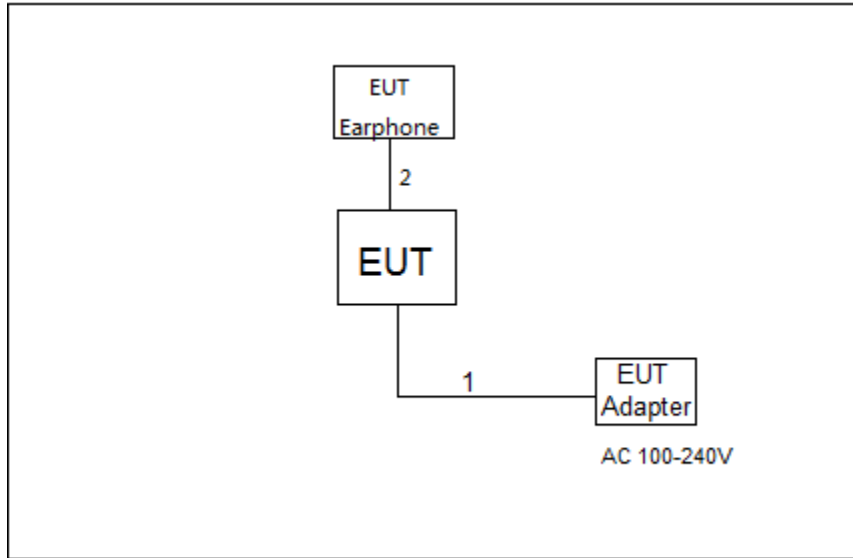

**2.6 SUPPORT UNITS**

Item	Equipment	Brand	Model No.	Series No.
-	-	-	-	-

Item	Cable Type	Shielded Type	Ferrite Core	Length
1	USB Cable	YES	NO	1m
2	Audio Cable	NO	NO	1m

### 3. AC POWER LINE CONDUCTED EMISSIONS TEST

#### 3.1 LIMIT

Frequency (MHz)	Limit (dBµV)	
	Quasi-peak	Average
0.15 - 0.5	66 to 56*	56 to 46*
0.5 - 5.0	56	46
5.0 - 30.0	60	50

NOTE:

- (1) The tighter limit applies at the band edges.
- (2) The limit of " \* " marked band means the limitation decreases linearly with the logarithm of the frequency in the range.

The following table is the setting of the receiver

Receiver Parameter	Setting
Attenuation	10 dB
Start Frequency	0.15 MHz
Stop Frequency	30 MHz
IF Bandwidth	9 KHz

#### 3.2 TEST PROCEDURE

- a. The EUT was placed 0.8 meters from the horizontal ground plane with EUT being connected to the power mains through a line impedance stabilization network (LISN). All other support equipment powered from additional LISN(s). The LISN provide 50 Ohm/ 50uH of coupling impedance for the measuring instrument.
- b. Interconnecting cables that hang closer than 40 cm to the ground plane shall be folded back and forth in the center forming a bundle 30 to 40 cm long.
- c. I/O cables that are not connected to a peripheral shall be bundled in the center. The end of the cable may be terminated, if required, using the correct terminating impedance. The overall length shall not exceed 1 m.
- d. LISN at least 80 cm from nearest part of EUT chassis.
- e. For the actual test configuration, please refer to the related Item -EUT Test Photos.

#### 3.3 DEVIATION FROM TEST STANDARD

No deviation

### 3.4 TEST SETUP

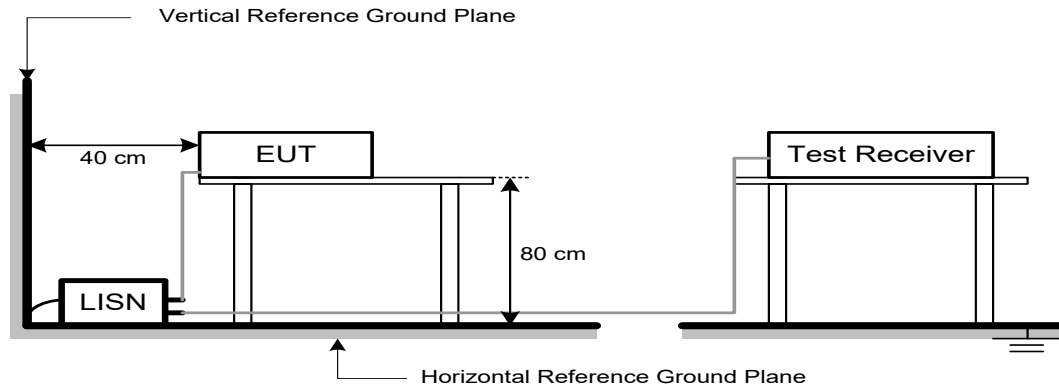

### 3.5 EUT OPERATION CONDITIONS

The EUT was configured for testing in a typical fashion (as a customer would normally use it). The EUT has been programmed to continuously transmit during test. This operating condition was tested and used to collect the included data.

The EUT was programmed to be in continuously transmitting/TX mode.

### 3.6 TEST RESULTS

Please refer to the APPENDIX A.

**4. RADIATED EMISSIONS TEST**

**4.1 LIMIT**

In case the emission fall within the restricted band specified on 15.205(a), then the 15.209(a) limit in the table below has to be followed.

**LIMITS OF RADIATED EMISSIONS MEASUREMENT (9 kHz to 1000 MHz)**

Frequency (MHz)	Field Strength (microvolts/meter)	Measurement Distance (meters)
0.009-0.490	2400/F(kHz)	300
0.490-1.705	24000/F(kHz)	30
1.705-30.0	30	30
30-88	100	3
88-216	150	3
216-960	200	3
Above 960	500	3

**LIMITS OF UNWANTED EMISSION OUT OF THE RESTRICTED BANDS**

Frequency (MHz)	EIRP Limit (dBm/MHz)	Equivalent Field Strength at 3m (dBμV/m)
5150-5250	-27	68.3
5250-5350	-27	68.3
5470-5725	-27	68.3
5725-5850	-27 NOTE (2)	68.3
	10 NOTE (2)	105.3
	15.6 NOTE (2)	110.9
	27 NOTE (2)	122.3

**NOTE:**

(1) The following formula is used to convert the equipment isotropic radiated power (eirp) to field strength:

$$E = \frac{1000000\sqrt{30P}}{3} \mu\text{V/m, where P is the eirp (Watts)}$$

(2) According to 15.407(b)(4)(i), all emissions shall be limited to a level of -27 dBm/MHz at 75 MHz or more above or below the band edge increasing linearly to 10 dBm/MHz at 25 MHz above or below the band edge, and from 25 MHz above or below the band edge increasing linearly to a level of 15.6 dBm/MHz at 5 MHz above or below the band edge, and from 5 MHz above or below the band edge increasing linearly to a level of 27 dBm/MHz at the band edge.

## 4.2 TEST PROCEDURE

- a. The measuring distance of 3 m shall be used for measurements. The EUT was placed on the top of a rotating table 0.8 meter above the ground at a 3 meter semi-anechoic chamber. The table was rotated 360 degrees to determine the position of the highest radiation.(below 1GHz)
- b. The measuring distance of 3 m shall be used for measurements. The EUT was placed on the top of a rotating table 1.5 meter above the ground at a 3 meter semi-anechoic chamber. The table was rotated 360 degrees to determine the position of the highest radiation.(above 1GHz)
- c. The height of the equipment or of the substitution antenna shall be 0.8m or 1.5m; the height of the test antenna shall vary between 1 m to 4 m. Both horizontal and vertical polarizations of the antenna are set to make the measurement.
- d. For each suspected emission, the EUT was arranged to its worst case and then the antenna was tuned to heights find the maximum reading (used Bore sight function).
- e. The receiver system was set to peak and average detect function and specified bandwidth with maximum hold mode when the test frequency is above 1 GHz.
- f. The initial step in collecting radiated emission data is a receiver peak detector mode pre-scanning the measurement frequency range. Significant peaks are then marked and then Quasi Peak detector mode re-measured.
- g. All readings are Peak unless otherwise stated QP in column of Note. Peak denotes that the Peak reading compliance with the QP Limits and then QP Mode measurement didn't perform. (below 1 GHz)
- h. All readings are Peak Mode value unless otherwise stated AVG in column of Note. If the Peak Mode Measured value compliance with the Peak Limits and lower than AVG Limits, the EUT shall be deemed to meet both Peak & AVG Limits and then only Peak Mode was measured, but AVG Mode didn't perform. (above 1 GHz)
- i. For the actual test configuration, please refer to the related Item –EUT Test Photos.

## 4.3 DEVIATION FROM TEST STANDARD

No deviation

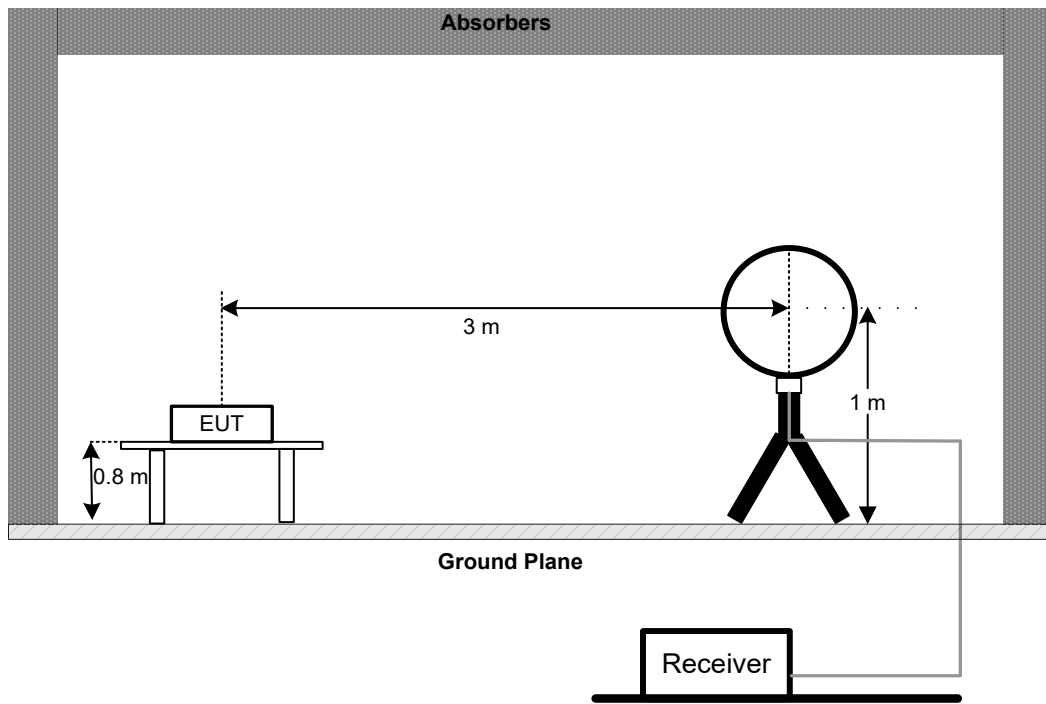
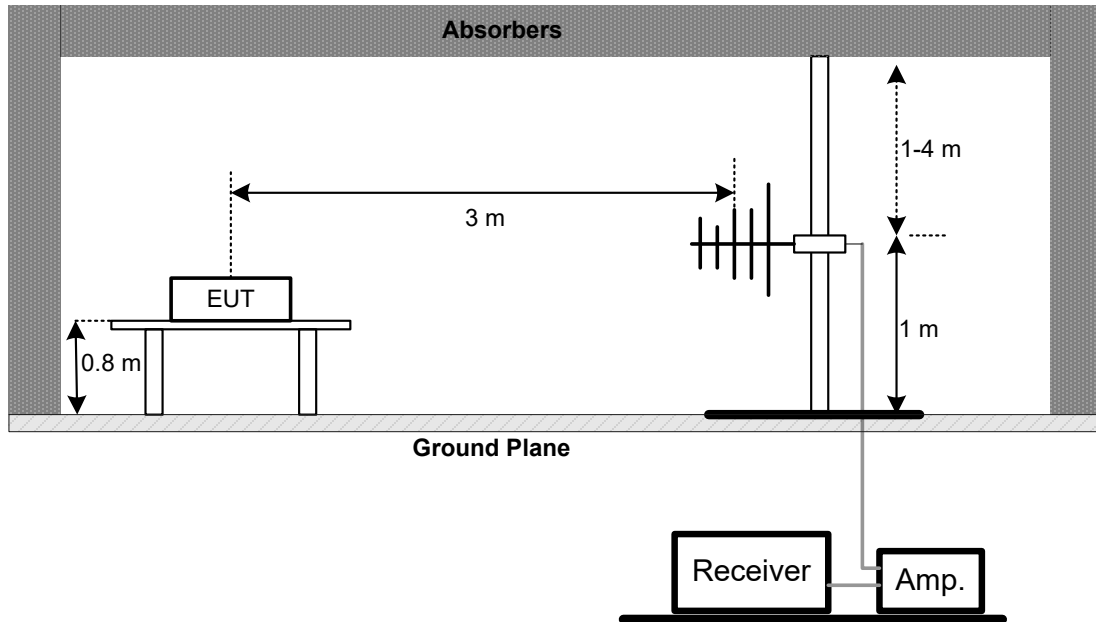
**4.4 TEST SETUP****9 kHz to 30 MHz****30 MHz to 1 GHz**



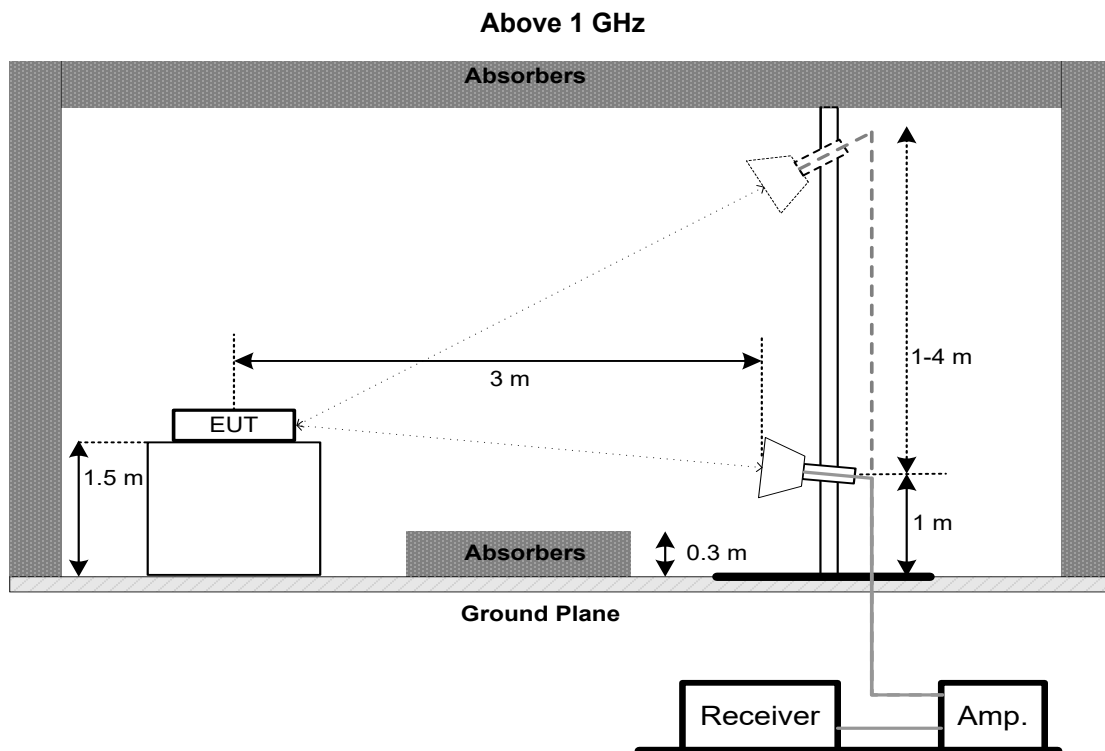

**4.5 EUT OPERATION CONDITIONS**

The EUT tested system was configured as the statements of 3.5 unless otherwise a special operating condition is specified in the follows during the testing.

**4.6 TEST RESULTS - 9 KHZ to 30 MHZ**

Please refer to the APPENDIX B

Remark:

- (1) The amplitude of spurious emissions which are attenuated by more than 20 dB below the permissible value has no need to be reported.
- (2) Distance extrapolation factor =  $40 \log (\text{specific distance} / \text{test distance})$  (dB).
- (3) Limit line = specific limits (dBuV) + distance extrapolation factor.

**4.7 TEST RESULTS - 30 MHZ TO 1000 MHZ**

Please refer to the APPENDIX C.

**4.8 TEST RESULTS - ABOVE 1000 MHZ**

Please refer to the APPENDIX D.

Remark:

- (1) No limit: This is fundamental signal, the judgment is not applicable.  
For fundamental signal judgment was referred to Peak output test.

## 5. BANDWIDTH TEST

### 5.1 LIMIT

FCC Part15, Subpart E (15.407)			
Section	Test Item	Limit	Frequency Range (MHz)
15.407(a)	26 dB Bandwidth	-	5150-5250
	26 dB Bandwidth	-	5250-5350
15.407(e)	26 dB Bandwidth	-	5470-5725
	6 dB Bandwidth	Minimum 500 kHz	5725-5850

### 5.2 TEST PROCEDURE

a. The EUT was directly connected to the spectrum analyzer and antenna output port as show in the block diagram below

b. Spectrum Setting:

For UNII-1, UNII-2A, UNII-2C:

Spectrum Parameter	Setting
Attenuation	Auto
Span Frequency	> 26 dB Bandwidth
RBW	300 kHz (Bandwidth 20 MHz) 1 MHz (Bandwidth 40 MHz and 80 MHz)
VBW	1 MHz (Bandwidth 20 MHz) 3 MHz (Bandwidth 40 MHz and 80 MHz)
Detector	Peak
Trace	Max Hold
Sweep Time	Auto

For UNII-3:

Spectrum Parameter	Setting
Attenuation	Auto
Span Frequency	6 dB Bandwidth
RBW	100 kHz
VBW	300 kHz
Detector	Peak
Trace	Max Hold
Sweep Time	Auto

c. Measured the spectrum width with power higher than 26 dB/6 dB below carrier

### 5.3 TEST PROCEDURE

No deviation.

**5.4 TEST SETUP****5.5 EUT OPERATION CONDITIONS**

The EUT was programmed to be in continuously transmitting mode.

**5.6 TEST RESULTS**

Please refer to the APPENDIX E.

**6. MAXIMUM OUTPUT POWER TEST**

**6.1 LIMIT**

FCC Part15, Subpart E (15.407)			
Section	Test Item	Limit	Frequency Range (MHz)
15.407(a)	Conducted Output Power	AP device: 1 Watt (30 dBm) Client device: 250 mW (24 dBm)	5150-5250
		250 mW (24 dBm)	5250-5350
		250 mW (24 dBm)	5470-5725
		1 Watt (30dBm)	5725-5850

Note:

- a. For an indoor access point operating in the band 5.15-5.25 GHz, the maximum conducted output power over the frequency band of operation shall not exceed 1 W provided the maximum antenna gain does not exceed 6 dBi. In addition, the maximum power spectral density shall not exceed 17 dBm in any 1 megahertz band. If transmitting antennas of directional gain greater than 6 dBi are used, both the maximum conducted output power and the maximum power spectral density shall be reduced by the amount in dB that the directional gain of the antenna exceeds 6 dBi.
- b. For the 5.25-5.35 GHz and 5.47-5.725 GHz bands, the maximum conducted output power over the frequency bands of operation shall not exceed the lesser of 250 mW or 11 dBm + 10log B, where B is the 26dB Bandwidth in megahertz.

**6.2 TEST PROCEDURE**

- a. The EUT was directly connected to the power meter and antenna output port as show in the block diagram below.
- b. Test test was performed in accordance with method of FCC KDB 789033 D02 General UNII Test Procedures New Rules v02r01.

**6.3 DEVIATION FROM STANDARD**

No deviation.

**6.4 TEST SETUP**

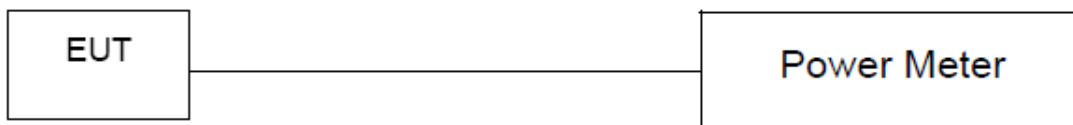

**6.5 EUT OPERATION CONDITIONS**

The EUT was programmed to be in continuously transmitting mode.

**6.6 TEST RESULTS**

Please refer to the APPENDIX F.

## 7. POWER SPECTRAL DENSITY TEST

### 7.1 LIMIT

FCC Part15, Subpart E (15.407)			
Section	Test Item	Limit	Frequency Range (MHz)
15.407(a)	Power Spectral Density	AP device: 17 dBm/MHz Client device: 11 dBm/MHz	5150-5250
		11 dBm/MHz	5250-5350
		11 dBm/MHz	5470-5725
		30 dBm/500 kHz	5725-5850

### 7.2 TEST PROCEDURE

- a. The EUT was directly connected to the spectrum analyzer and antenna output port as show in the block diagram below.
- b. Spectrum Setting

Spectrum Parameter	Setting
Attenuation	Auto
Span Frequency	Encompass the entire emissions bandwidth (EBW) of the signal
RBW	= 1 MHz.
VBW	≥ 3 MHz.
Detector	RMS
Trace average	100 trace
Sweep <input type="checkbox"/> ime	Auto

Note:

1. For UNII-3, according to KDB publication 789033 D02 General UNII Test Procedures New Rules v02r01, section II.F.5., it is acceptable to set RBW at 1 MHz and VBW at 3 MHz if the spectrum analyzer does not have 500 kHz RBW.
2. The value measured with RBW=1 MHz is to be added with  $10\log(500\text{ kHz}/1\text{ MHz})$  which is -3 dB. For example, if the measured value is +10dBm using RBW=1 MHz (that is +10 dBm/MHz), then the converted value will be +7dBm/500kHz.

### 7.3 DEVIATION FROM STANDARD

No deviation.

### 7.4 TEST SETUP



### 7.5 EUT OPERATION CONDITIONS

The EUT was programmed to be in continuously transmitting mode.

### 7.6 TEST RESULTS

Please refer to the APPENDIX G.

## 8. FREQUENCY STABILITY MEASUREMENT

### 8.1 LIMIT

FCC Part15, Subpart E (15.407)			
Section	Test Item	Limit	Frequency Range (MHz)
15.407(g)	Frequency Stability	An emission is maintained within the band of operation under all conditions of normal operation as specified in the users manual.	5150-5250
			5250-5350
			5470-5725
			5725-5850

### 8.2 TEST PROCEDURE

- a. The EUT was directly connected to the spectrum analyzer and antenna output port as show in the block diagram below.
- b. Spectrum Setting:

Spectrum Parameter	Setting
Attenuation	Auto
Span Frequency	Entire absence of modulation emissions bandwidth
RBW	10 kHz
VBW	10 kHz
Sweep Time	Auto

- c. User manual voltage is DC 3.5V ~ 4.45V.
- d. User manual temperature is 0°C~35°C.

### 8.3 DEVIATION FROM STANDARD

No deviation.

### 8.4 TEST SETUP

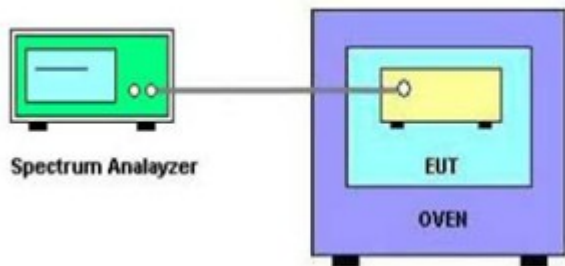

### 8.5 EUT OPERATION CONDITIONS

The EUT was programmed to be in continuously transmitting mode.

### 8.6 TEST RESULTS

Please refer to the APPENDIX H.

**9. MEASUREMENT INSTRUMENTS LIST**

AC Power Line Conducted Emissions					
Item	Kind of Equipment	Manufacturer	Type No.	Serial No.	Calibrated until
1	EMI Test Receiver	R&S	ESCI	100382	Feb. 28, 2021
2	LISN	EMCO	3816/2	52765	Mar. 01, 2021
3	TWO-LINE V-NETWORK	R&S	ENV216	101447	Feb. 28, 2021
4	50Ω Terminator	SHX	TF5-3	15041305	Mar. 01, 2021
5	Measurement Software	Farad	EZ-EMC Ver.NB-03A1-01	N/A	N/A
6	Cable	N/A	RG223	12m	Mar. 10, 2021

Radiated Emissions - 9 kHz to 30 MHz					
Item	Kind of Equipment	Manufacturer	Type No.	Serial No.	Calibrated until
1*	Antenna	EM	EM-6876-1	230	Apr. 16, 2021
2	Cable	N/A	RG 213/U	C-102	May 31, 2020
3	EMI Test Receiver	R&S	ESCI	100895	Feb. 28, 2021
4	Measurement Software	Farad	EZ-EMC Ver.NB-03A1-01	N/A	N/A

Radiated Emissions - 30 MHz to 1 GHz					
Item	Kind of Equipment	Manufacturer	Type No.	Serial No.	Calibrated until
1	Antenna	Schwarzbeck	VULB9160	9160-3232	Mar. 09, 2021
2*	Amplifier	HP	8447D	2944A09673	Mar. 01, 2021
3	Receiver	Agilent	N9038A	MY52130039	Aug. 03, 2020
4	Cable	emci	LMR-400(30MHz-1 GHz)(8m+5m)	N/A	May 25, 2020
5	Controller	CT	SC100	N/A	N/A
6	Controller	MF	MF-7802	MF780208416	N/A
7	Measurement Software	Farad	EZ-EMC Ver.NB-03A1-01	N/A	N/A

Radiated Emissions - Above 1 GHz					
Item	Kind of Equipment	Manufacturer	Type No.	Serial No.	Calibrated until
1	Double Ridged Guide Antenna	ETS	3115	75846	Mar. 19, 2021
2	Broad-Band Horn Antenna	Schwarzbeck	BBHA 9170	9170319	Jun. 23, 2020
3	Amplifier	Agilent	8449B	3008A02333	Mar. 01, 2021
4	Microwave Preamplifier With Adaptor	EMC INSTRUMENT	EMC2654045	980039 & HA01	Mar. 07, 2021
5	Receiver	Agilent	N9038A	MY52130039	Aug. 03, 2020
6	Controller	CT	SC100	N/A	N/A
7	Controller	MF	MF-7802	MF780208416	N/A
8	Cable	mitron	RWLP50-4.0A-KJ-S MSM-12M	N/A	Nov. 25, 2020
9	Measurement Software	Farad	EZ-EMC Ver.NB-03A1-01	N/A	N/A

Bandwidth & Conducted Output Power & Power Spectral Density					
Item	Kind of Equipment	Manufacturer	Type No.	Serial No.	Calibrated until
1	Spectrum Analyzer	R&S	FSP40	100185	Aug. 03, 2020

Frequency Stability					
Item	Kind of Equipment	Manufacturer	Type No.	Serial No.	Calibrated until
1	Spectrum Analyzer	R&S	FSP40	100185	Aug. 03, 2020
2	Precision Oven Tester	Bell	BTH-50C	20170306001	Mar. 10, 2020

Remark: "N/A" denotes no model name, serial no. or calibration specified.

"\*\*" calibration period of equipment list is three year.

Except \* item, all calibration period of equipment list is one year.



## **APPENDIX A - AC POWER LINE CONDUCTED EMISSIONS**

Test Mode: TX A MODE CHANNEL 60

Line

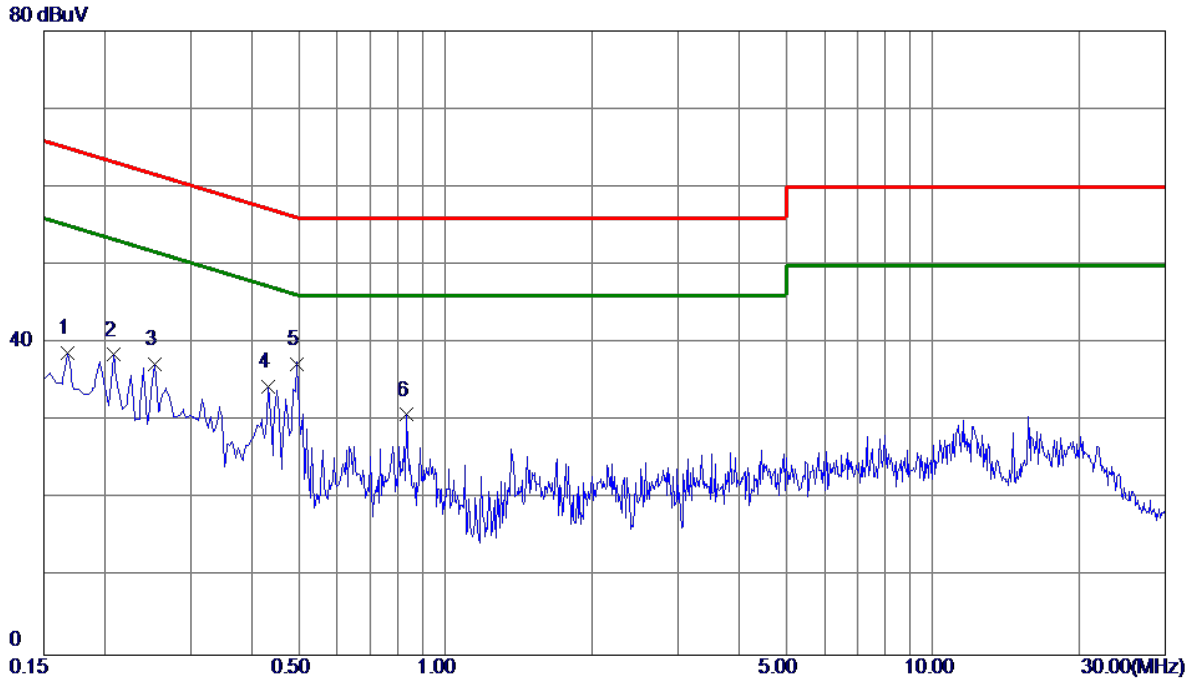

No.	Freq. MHz	Reading Level dBuV	Correct Factor dB	Measure ment dBuV	Limit dBuV	Margin dB	Detector	Comment
1	0.1680	28.89	9.80	38.69	65.06	-26.37	Peak	
2	0.2085	28.58	9.90	38.48	63.26	-24.78	Peak	
3	0.2535	27.33	9.88	37.21	61.64	-24.43	Peak	
4	0.4335	24.48	9.93	34.41	57.19	-22.78	Peak	
5 *	0.4967	27.28	9.95	37.23	56.06	-18.83	Peak	
6	0.8340	20.81	9.99	30.80	56.00	-25.20	Peak	

REMARKS:

- (1) Measurement Value = Reading Level + Correct Factor.
- (2) Margin Level = Measurement Value - Limit Value.
- (3) The test result has included the cable loss.

Test Mode: TX A MODE CHANNEL 60

Neutral

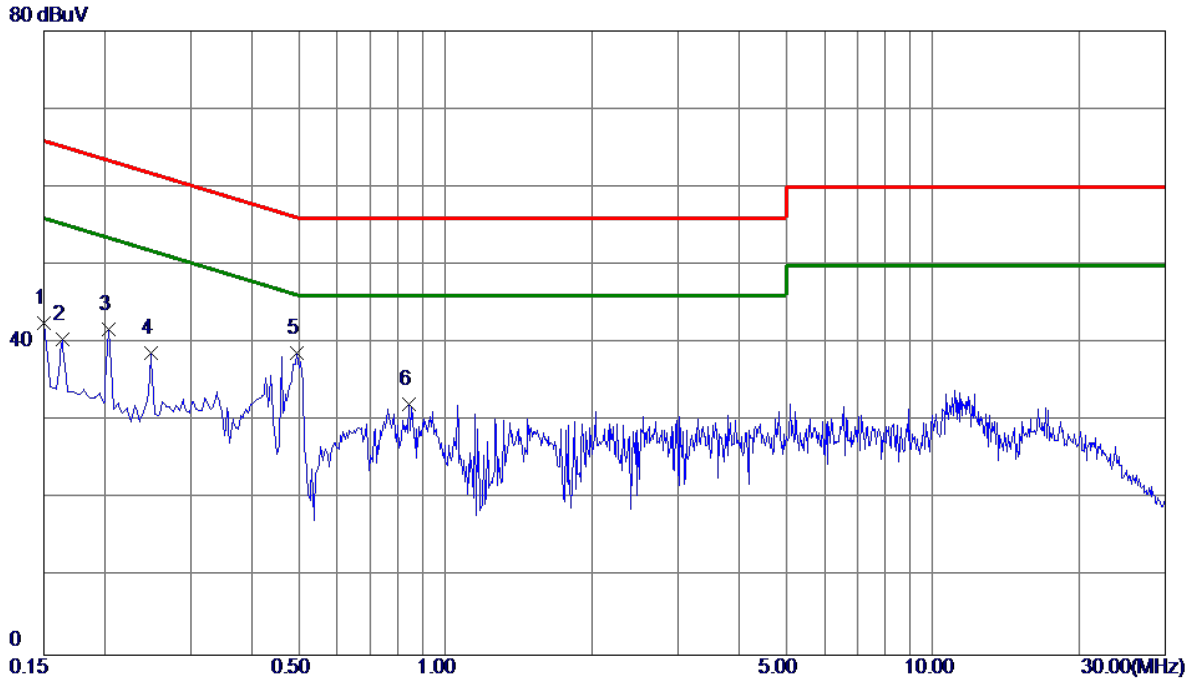

No.	Freq. MHz	Reading Level dBuV	Correct Factor dB	Measure ment dBuV	Limit dBuV	Margin dB	Detector	Comment
1	0.1500	32.79	9.74	42.53	66.00	-23.47	Peak	
2	0.1635	30.58	9.85	40.43	65.28	-24.85	Peak	
3	0.2040	31.82	10.01	41.83	63.45	-21.62	Peak	
4	0.2490	28.67	9.98	38.65	61.79	-23.14	Peak	
5 *	0.4965	28.52	10.14	38.66	56.06	-17.40	Peak	
6	0.8430	21.95	10.25	32.20	56.00	-23.80	Peak	

Note: The test result has included the cable loss.

REMARKS:

- (1) Measurement Value = Reading Level + Correct Factor.
- (2) Margin Level = Measurement Value - Limit Value.
- (3) The test result has included the cable loss.

## **APPENDIX B - RADIATED EMISSION - 9 KHZ TO 30 MHZ**

Test Mode: TX A MODE CHANNEL 60

Ant 0°

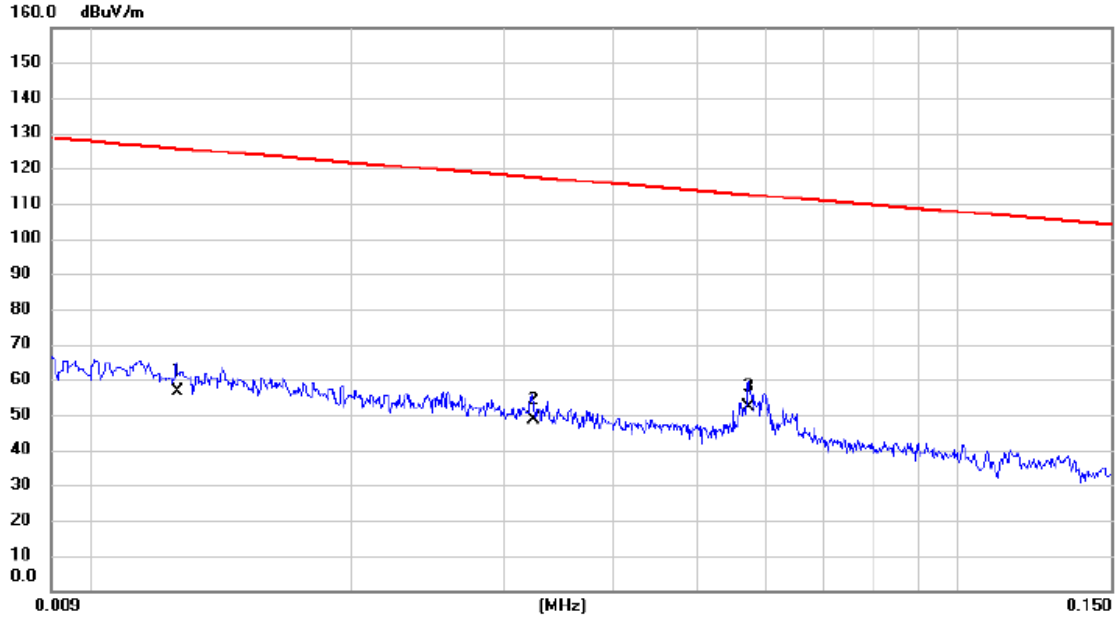

No.	Mk.	Freq. MHz	Reading Level dBuV	Correct Factor dB	Measure- ment dBuV/m	Limit dBuV/m	Margin dB	Detector	Comment
1		0.0126	40.58	16.04	56.62	125.60	-68.98	AVG	
2		0.0324	34.59	13.87	48.46	117.39	-68.93	AVG	
3	*	0.0573	38.44	13.81	52.25	112.44	-60.19	AVG	

REMARKS:

- (1) Measurement Value = Reading Level + Correct Factor.
- (2) Margin Level = Measurement Value - Limit Value.

Test Mode: TX A MODE CHANNEL 60

Ant 0°

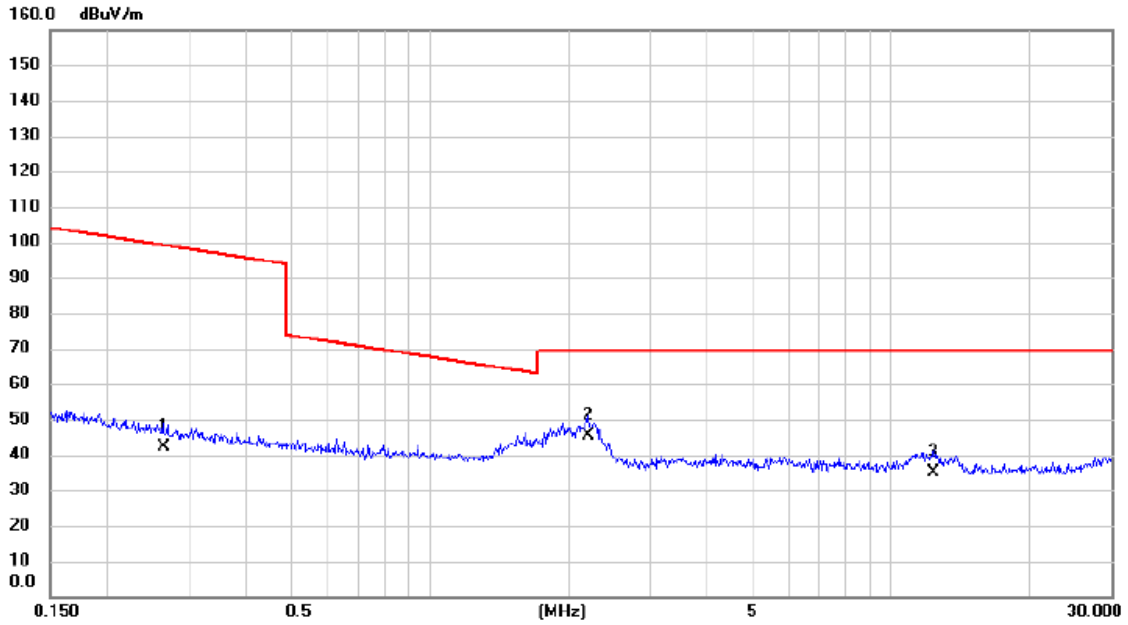

No.	Mk.	Freq. MHz	Reading Level dBuV	Correct Factor dB	Measure- ment dBuV/m	Limit dBuV/m	Margin dB	Detector	Comment
1		0.2644	28.41	13.63	42.04	99.16	-57.12	AVG	
2	*	2.2015	33.69	11.70	45.39	69.54	-24.15	QP	
3		12.3837	23.47	11.60	35.07	69.54	-34.47	QP	

REMARKS:

- (1) Measurement Value = Reading Level + Correct Factor.
- (2) Margin Level = Measurement Value - Limit Value.

Test Mode: TX A MODE CHANNEL 60

Ant 90°

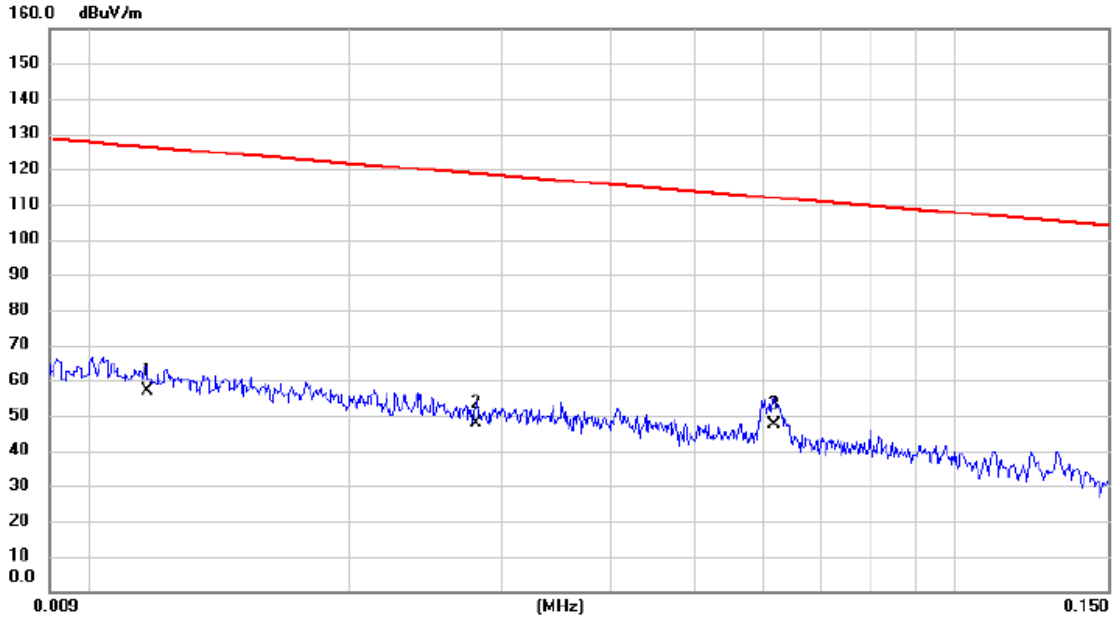

No.	Mk.	Freq. MHz	Reading Level dBuV	Correct Factor dB	Measure- ment dBuV/m	Limit dBuV/m	Margin dB	Detector	Comment
1		0.0117	40.62	16.31	56.93	126.24	-69.31	AVG	
2		0.0280	34.15	13.85	48.00	118.66	-70.66	AVG	
3	*	0.0618	33.68	13.74	47.42	111.79	-64.37	AVG	

REMARKS:

- (1) Measurement Value = Reading Level + Correct Factor.
- (2) Margin Level = Measurement Value - Limit Value.

Test Mode: TX A MODE CHANNEL 60

Ant 90°

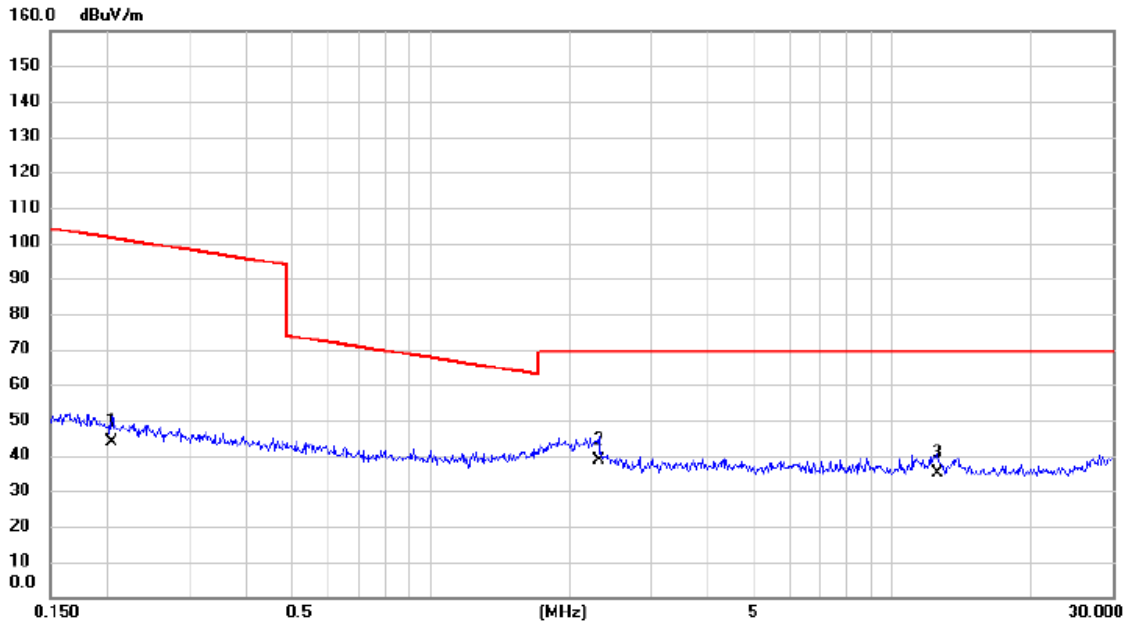

No.	Mk.	Freq. MHz	Reading Level dBuV	Correct Factor dB	Measure- ment dBuV/m	Limit dBuV/m	Margin dB	Detector	Comment
1		0.2040	30.25	13.61	43.86	101.41	-57.55	AVG	
2	*	2.3090	26.97	11.63	38.60	69.54	-30.94	QP	
3		12.5156	23.48	11.60	35.08	69.54	-34.46	QP	

REMARKS:

- (1) Measurement Value = Reading Level + Correct Factor.
- (2) Margin Level = Measurement Value - Limit Value.



**APPENDIX C - RADIATED EMISSION - 30 MHZ TO 1 GHZ**

Test Mode: TX A MODE CHANNEL 60

### Vertical

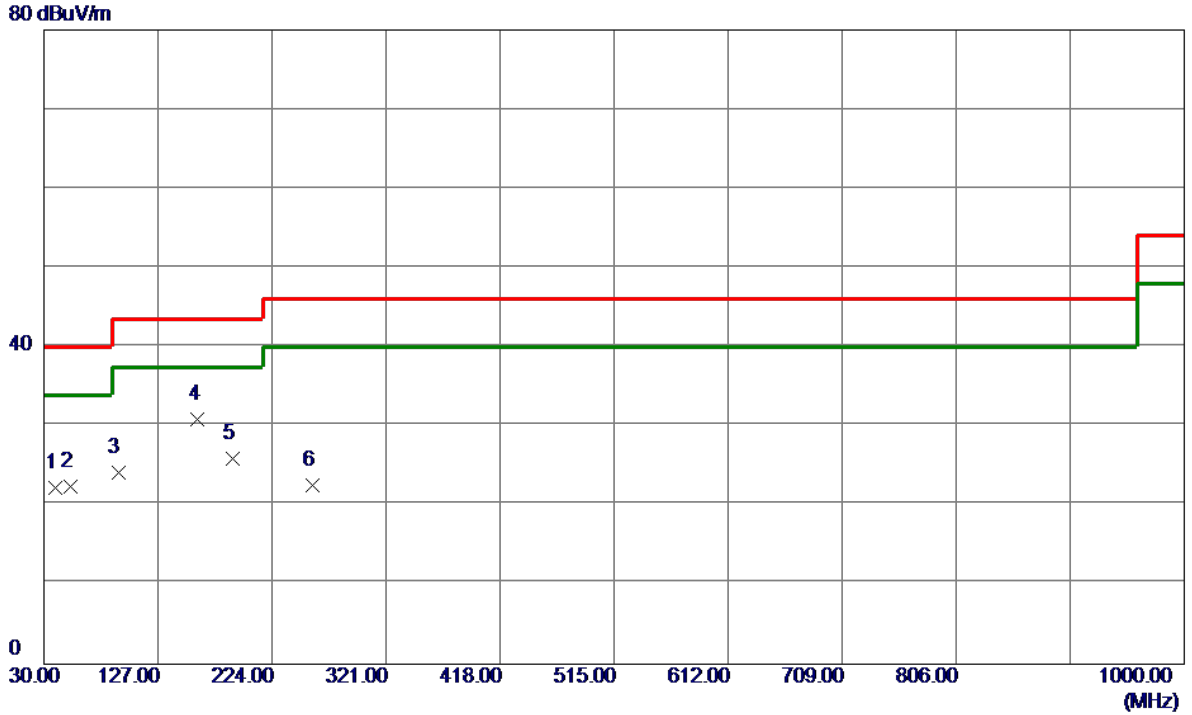

No.	Freq. MHz	Reading Level dBuV/m	Correct Factor dB	Measure ment dBuV/m	Limit dBuV/m	Margin dB	Detector	Comment
1	39.7000	35.89	-13.71	22.18	40.00	-17.82	Peak	
2	52.3100	36.23	-13.88	22.35	40.00	-17.65	Peak	
3	93.0500	39.98	-15.77	24.21	43.50	-19.29	Peak	
4 *	160.9500	42.16	-11.26	30.90	43.50	-12.60	Peak	
5	190.0500	40.59	-14.60	25.99	43.50	-17.51	Peak	
6	258.9200	35.55	-12.92	22.63	46.00	-23.37	Peak	

**REMARKS:**

- (1) Measurement Value = Reading Level + Correct Factor.
- (2) Margin Level = Measurement Value - Limit Value.

Test Mode: TX A MODE CHANNEL 60

### Horizontal

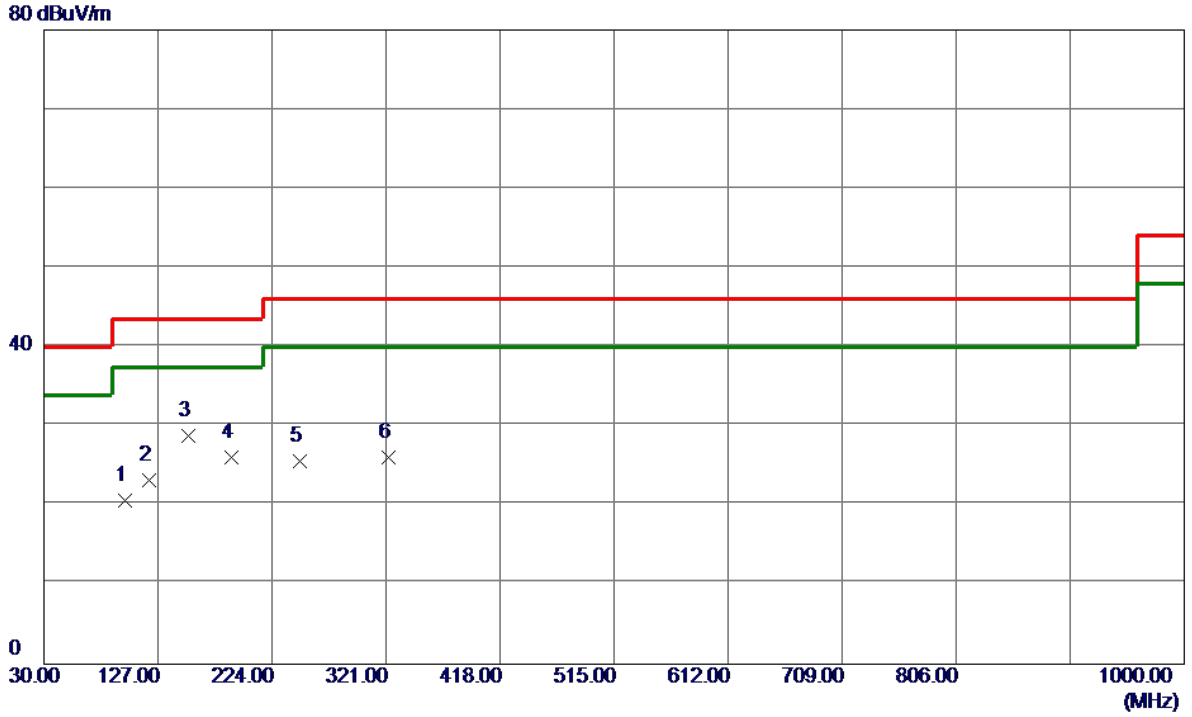

No.	Freq. MHz	Reading Level dBuV/m	Correct Factor dB	Measure ment dBuV/m	Limit dBuV/m	Margin dB	Detector	Comment
1	98.8700	35.97	-15.34	20.63	43.50	-22.87	Peak	
2	119.2400	36.39	-13.23	23.16	43.50	-20.34	Peak	
3 *	153.1900	40.78	-11.99	28.79	43.50	-14.71	Peak	
4	189.0800	40.56	-14.48	26.08	43.50	-17.42	Peak	
5	247.2800	39.53	-13.95	25.58	46.00	-20.42	Peak	
6	322.9400	37.41	-11.28	26.13	46.00	-19.87	Peak	

**REMARKS:**

- (1) Measurement Value = Reading Level + Correct Factor.
- (2) Margin Level = Measurement Value - Limit Value.

## **APPENDIX D - RADIATED EMISSION - ABOVE 1000 MHZ**

Orthogonal Axis	X
Test Mode	UNII-1_TX A Mode 5180 MHz

### Vertical

130 dBuV/m

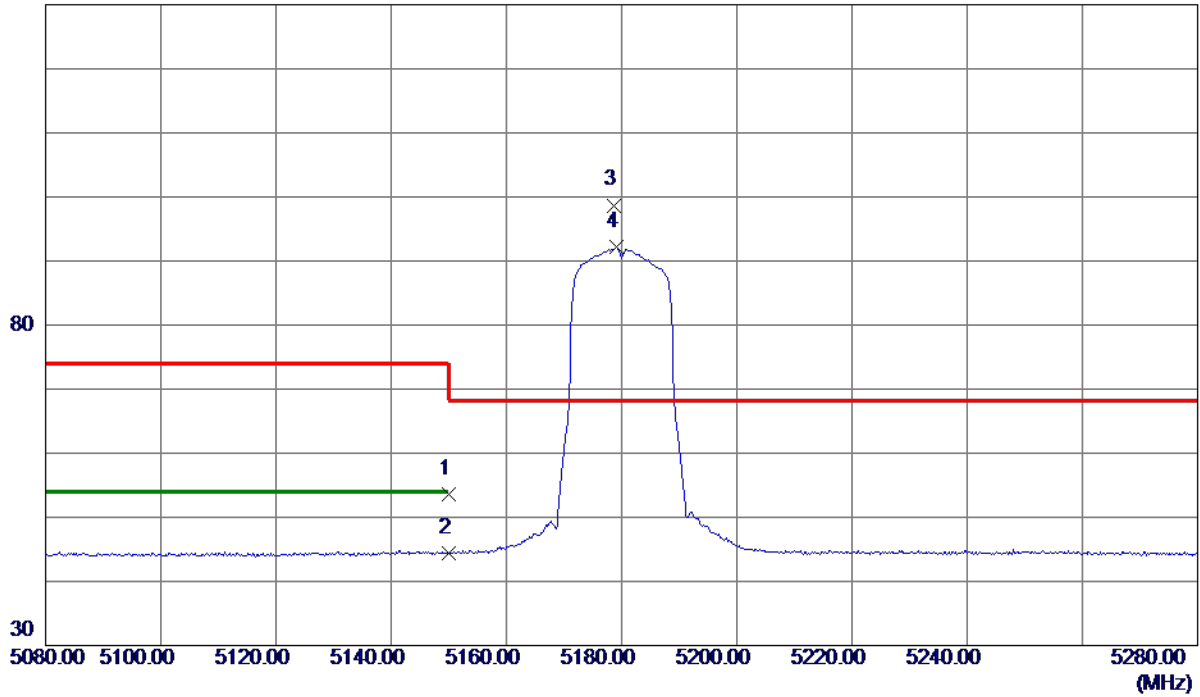

No.	Freq. MHz	Reading Level dBuV/m	Correct Factor dB	Measure ment dBuV/m	Limit dBuV/m	Margin dB	Detector	Comment
1	5150.0000	39.11	14.51	53.62	74.00	-20.38	Peak	
2	5150.0000	29.82	14.51	44.33	54.00	-9.67	AVG	
3 *	5178.6000	84.12	14.58	98.70	68.30	30.40	Peak	No Limit
4	5179.2000	77.60	14.58	92.18	999.00	-906.82	AVG	No Limit

**REMARKS:**

- (1) Measurement Value = Reading Level + Correct Factor.
- (2) Margin Level = Measurement Value - Limit Value.

Orthogonal Axis	X
Test Mode	UNII-1_TX A Mode 5180 MHz

**Vertical**

80 dBuV/m

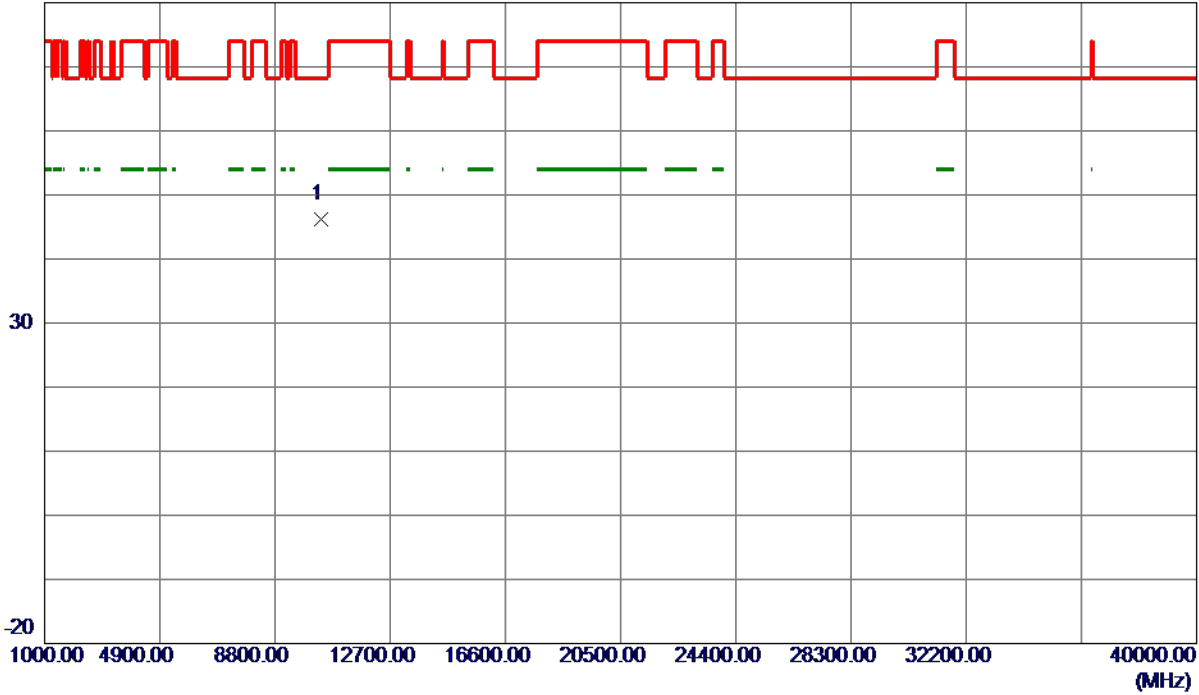

No.	Freq. MHz	Reading Level dBuV/m	Correct Factor dB	Measure ment dBuV/m	Limit dBuV/m	Margin dB	Detector	Comment
1 *	10359.8050	34.90	11.30	46.20	68.30	-22.10	Peak	

**REMARKS:**

- (1) Measurement Value = Reading Level + Correct Factor.
- (2) Margin Level = Measurement Value - Limit Value.

Orthogonal Axis	X
Test Mode	UNII-1_TX A Mode 5180 MHz

### Horizontal

130 dBuV/m

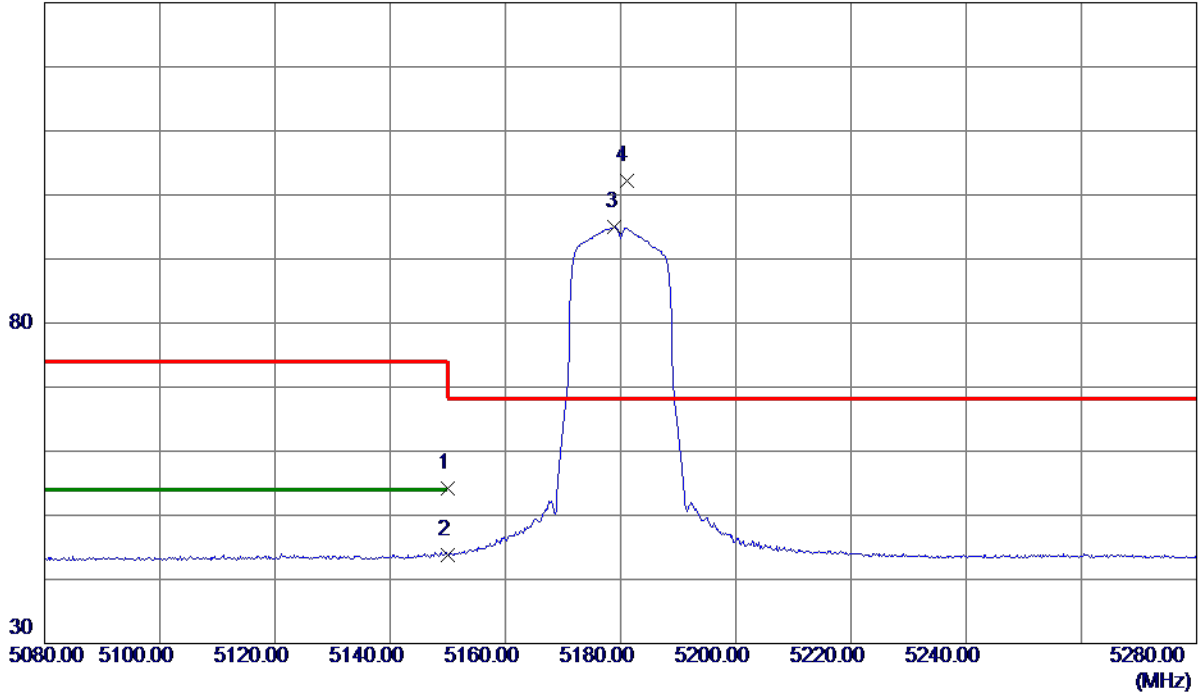

No.	Freq. MHz	Reading Level dBuV/m	Correct Factor dB	Measure ment dBuV/m	Limit dBuV/m	Margin dB	Detector	Comment
1	5150.0000	39.77	14.51	54.28	74.00	-19.72	Peak	
2	5150.0000	29.36	14.51	43.87	54.00	-10.13	AVG	
3	5179.0000	80.44	14.58	95.02	999.00	-903.98	AVG	No Limit
4 *	5181.0000	87.68	14.59	102.27	68.30	33.97	Peak	No Limit

**REMARKS:**

- (1) Measurement Value = Reading Level + Correct Factor.
- (2) Margin Level = Measurement Value - Limit Value.

Orthogonal Axis	X
Test Mode	UNII-1_TX A Mode 5180 MHz

### Horizontal

80 dBuV/m

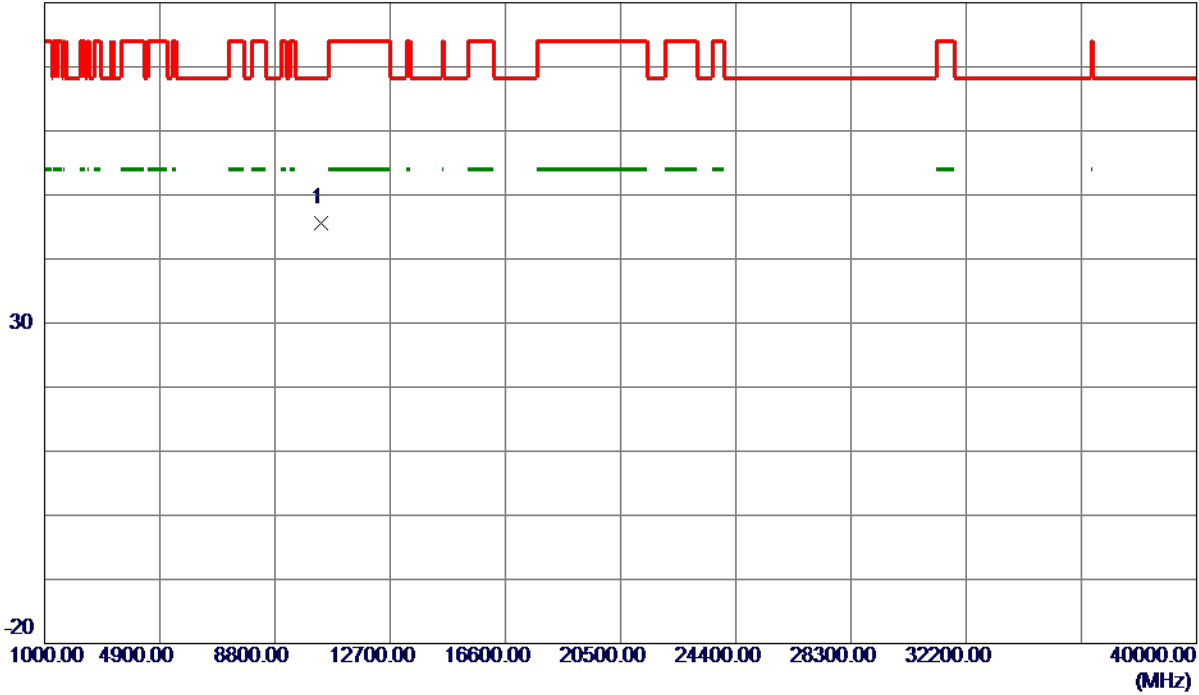

No.	Freq. MHz	Reading Level dBuV/m	Correct Factor dB	Measure ment dBuV/m	Limit dBuV/m	Margin dB	Detector	Comment
1 *	10360.4740	34.22	11.30	45.52	68.30	-22.78	Peak	

**REMARKS:**

- (1) Measurement Value = Reading Level + Correct Factor.
- (2) Margin Level = Measurement Value - Limit Value.



Orthogonal Axis	X
Test Mode	UNII-1_TX A Mode 5200 MHz

**Vertical**

130 dBuV/m

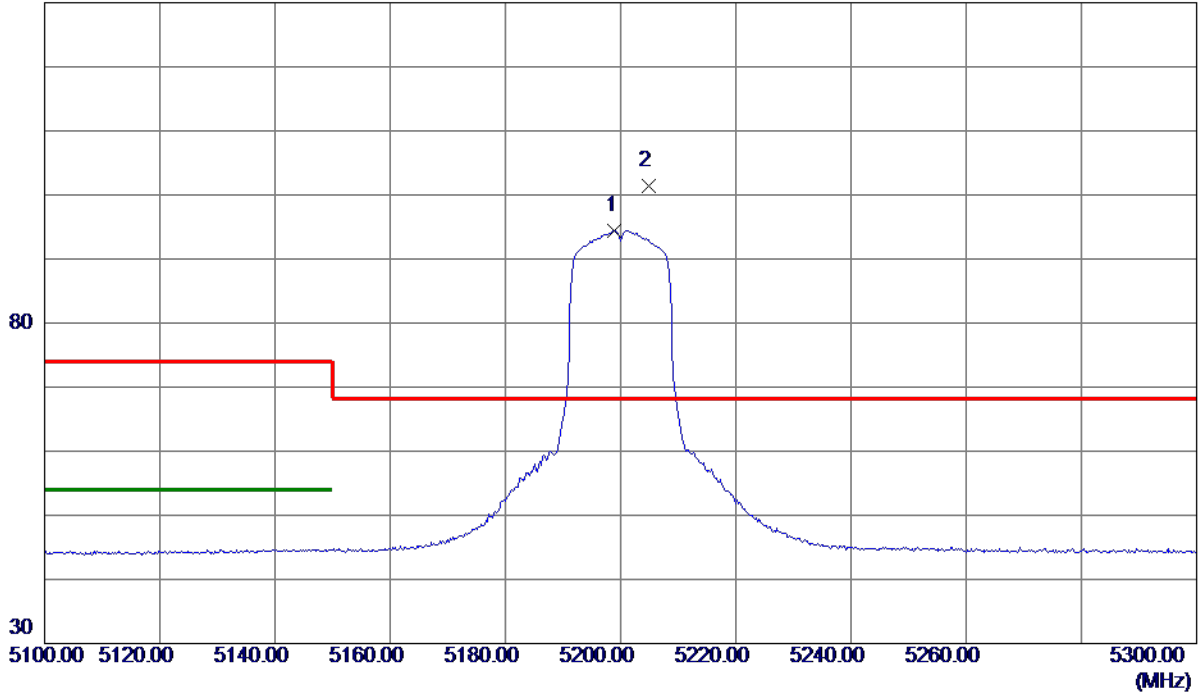

No.	Freq. MHz	Reading Level dBuV/m	Correct Factor dB	Measure ment dBuV/m	Limit dBuV/m	Margin dB	Detector	Comment
1	5199.0000	79.86	14.63	94.49	999.00	-904.51	AVG	No Limit
2 *	5204.8000	86.77	14.65	101.42	68.30	33.12	Peak	No Limit

**REMARKS:**

- (1) Measurement Value = Reading Level + Correct Factor.
- (2) Margin Level = Measurement Value - Limit Value.

Orthogonal Axis	X
Test Mode	UNII-1_TX A Mode 5200 MHz

**Vertical**

80 dBuV/m

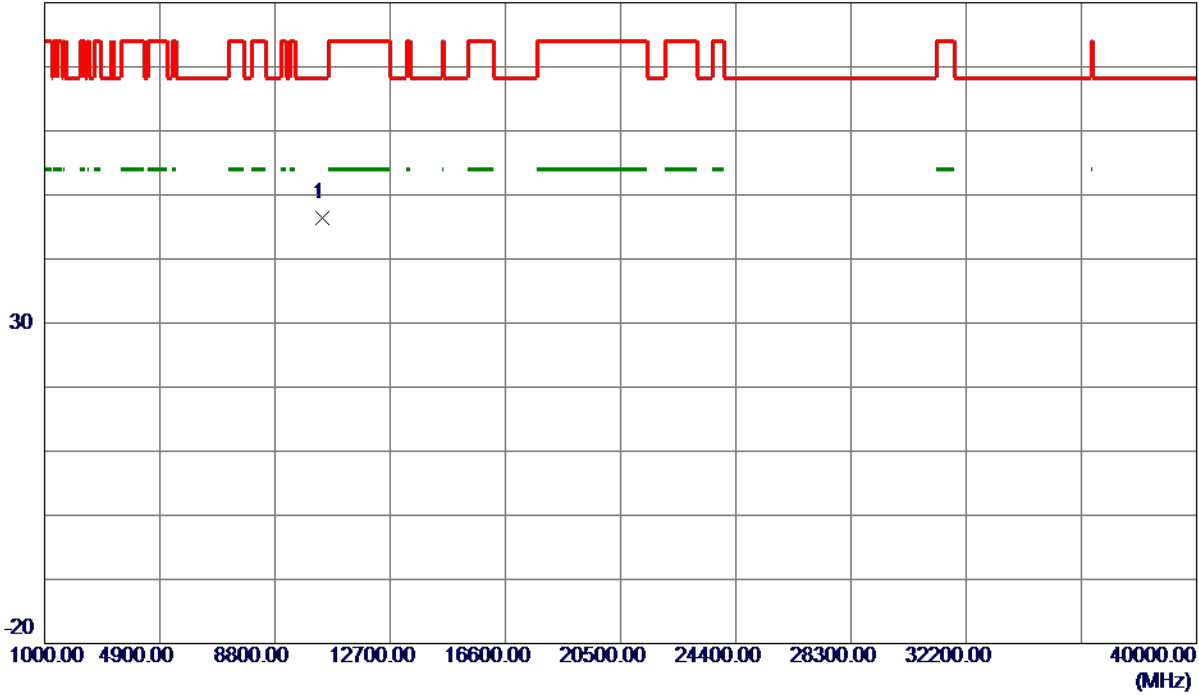

No.	Freq. MHz	Reading Level dBuV/m	Correct Factor dB	Measure ment dBuV/m	Limit dBuV/m	Margin dB	Detector	Comment
1 *	10400.2009	35.04	11.37	46.41	68.30	-21.89	Peak	

**REMARKS:**

- (1) Measurement Value = Reading Level + Correct Factor.
- (2) Margin Level = Measurement Value - Limit Value.

Orthogonal Axis	X
Test Mode	UNII-1_TX A Mode 5200 MHz

### Horizontal

130 dBuV/m

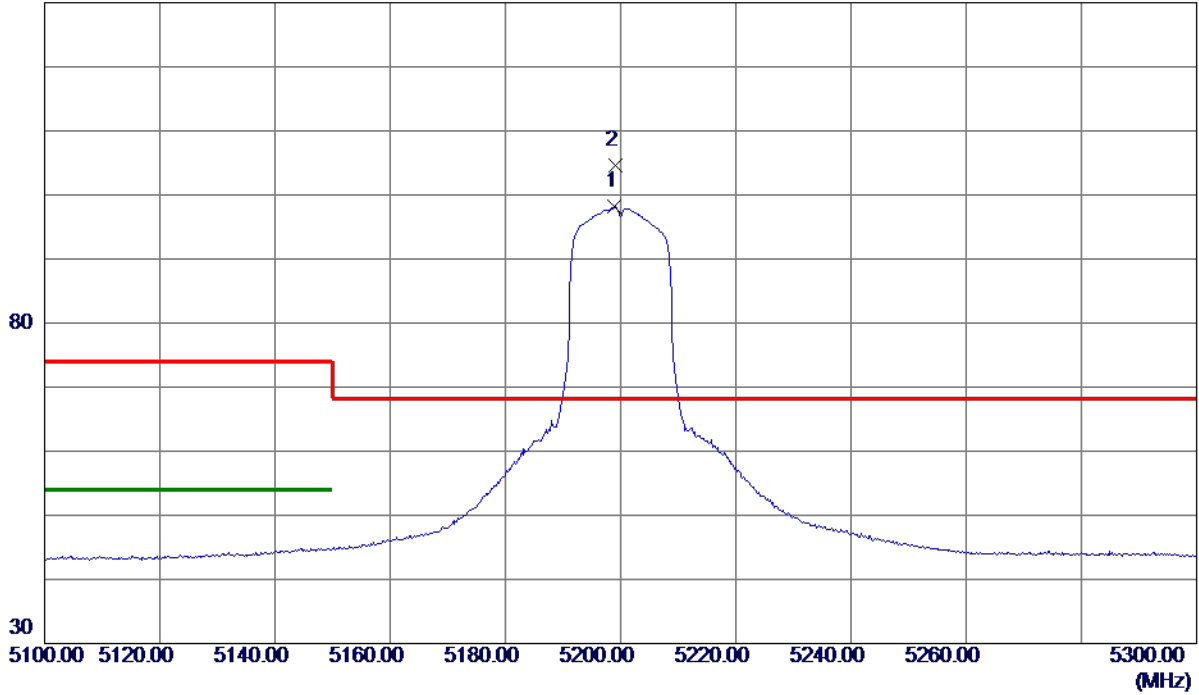

No.	Freq. MHz	Reading Level dBuV/m	Correct Factor dB	Measure ment dBuV/m	Limit dBuV/m	Margin dB	Detector	Comment
1	5199.0000	83.65	14.63	98.28	999.00	-900.72	AVG	No Limit
2 *	5199.2000	90.01	14.63	104.64	68.30	36.34	Peak	No Limit

**REMARKS:**

- (1) Measurement Value = Reading Level + Correct Factor.
- (2) Margin Level = Measurement Value - Limit Value.

Orthogonal Axis	X
Test Mode	UNII-1_TX A Mode 5200 MHz

### Horizontal

80 dBuV/m

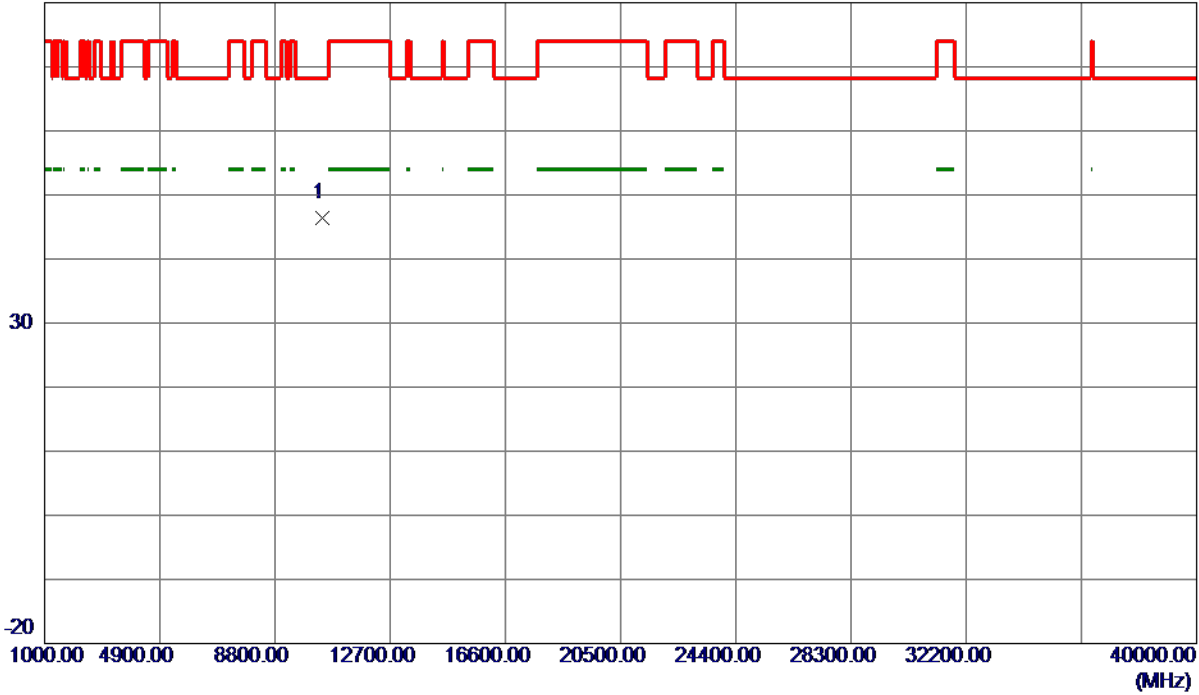

No.	Freq. MHz	Reading Level dBuV/m	Correct Factor dB	Measure ment dBuV/m	Limit dBuV/m	Margin dB	Detector	Comment
1 *	10400.2100	34.97	11.37	46.34	68.30	-21.96	Peak	

**REMARKS:**

- (1) Measurement Value = Reading Level + Correct Factor.
- (2) Margin Level = Measurement Value - Limit Value.

Orthogonal Axis	X
Test Mode	UNII-1_TX A Mode 5240 MHz

**Vertical**

130 dBuV/m

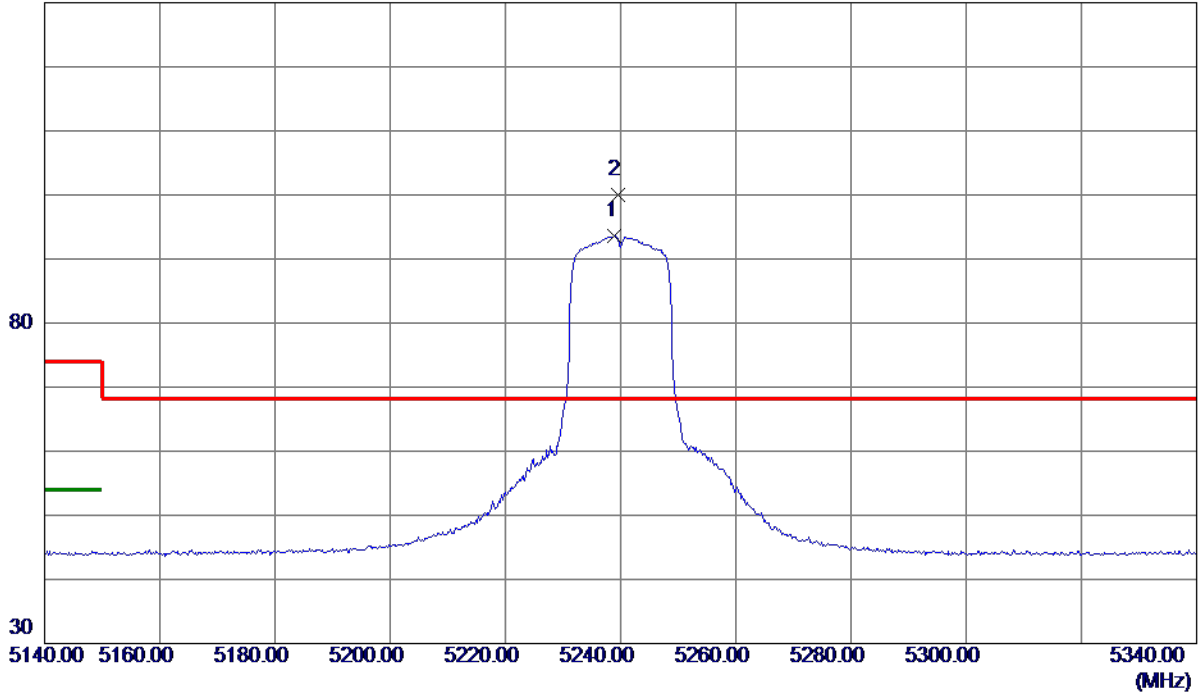

No.	Freq. MHz	Reading Level dBuV/m	Correct Factor dB	Measure ment dBuV/m	Limit dBuV/m	Margin dB	Detector	Comment
1	5239.0000	78.87	14.73	93.60	999.00	-905.40	AVG	No Limit
2 *	5239.6000	85.34	14.74	100.08	68.30	31.78	Peak	No Limit

**REMARKS:**

- (1) Measurement Value = Reading Level + Correct Factor.
- (2) Margin Level = Measurement Value - Limit Value.

Orthogonal Axis	X
Test Mode	UNII-1_TX A Mode 5240 MHz

**Vertical**

80 dBuV/m

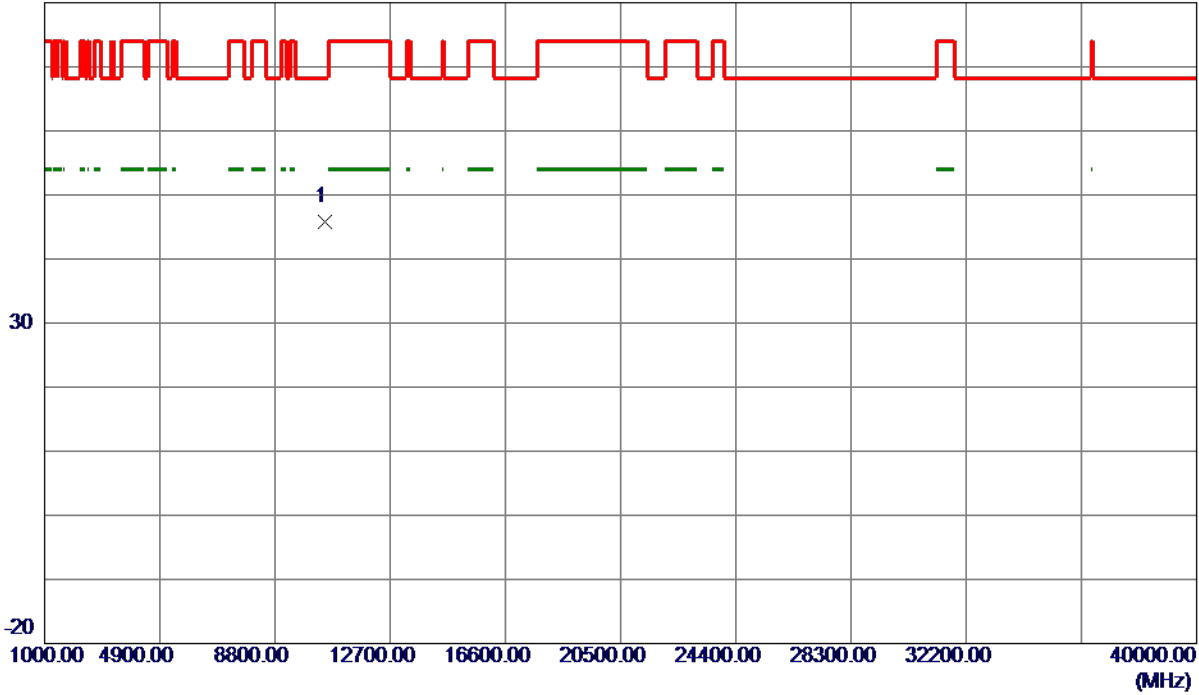

No.	Freq. MHz	Reading Level dBuV/m	Correct Factor dB	Measure ment dBuV/m	Limit dBuV/m	Margin dB	Detector	Comment
1 *	10479.5940	34.22	11.50	45.72	68.30	-22.58	Peak	

**REMARKS:**

- (1) Measurement Value = Reading Level + Correct Factor.
- (2) Margin Level = Measurement Value - Limit Value.

Orthogonal Axis	X
Test Mode	UNII-1_TX A Mode 5240 MHz

### Horizontal

130 dBuV/m

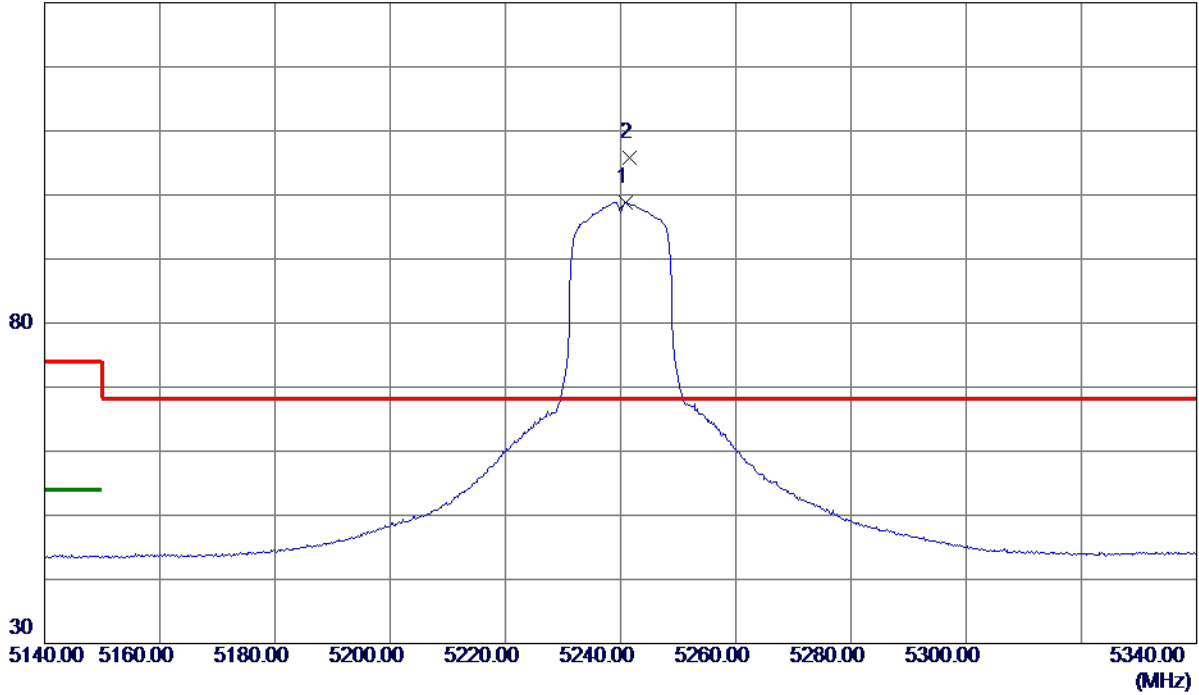

No.	Freq. MHz	Reading Level dBuV/m	Correct Factor dB	Measure ment dBuV/m	Limit dBuV/m	Margin dB	Detector	Comment
1	5240.8000	84.15	14.74	98.89	999.00	-900.11	AVG	No Limit
2 *	5241.6000	91.05	14.74	105.79	68.30	37.49	Peak	No Limit

**REMARKS:**

- (1) Measurement Value = Reading Level + Correct Factor.
- (2) Margin Level = Measurement Value - Limit Value.

Orthogonal Axis	X
Test Mode	UNII-1_TX A Mode 5240 MHz

### Horizontal

80 dBuV/m

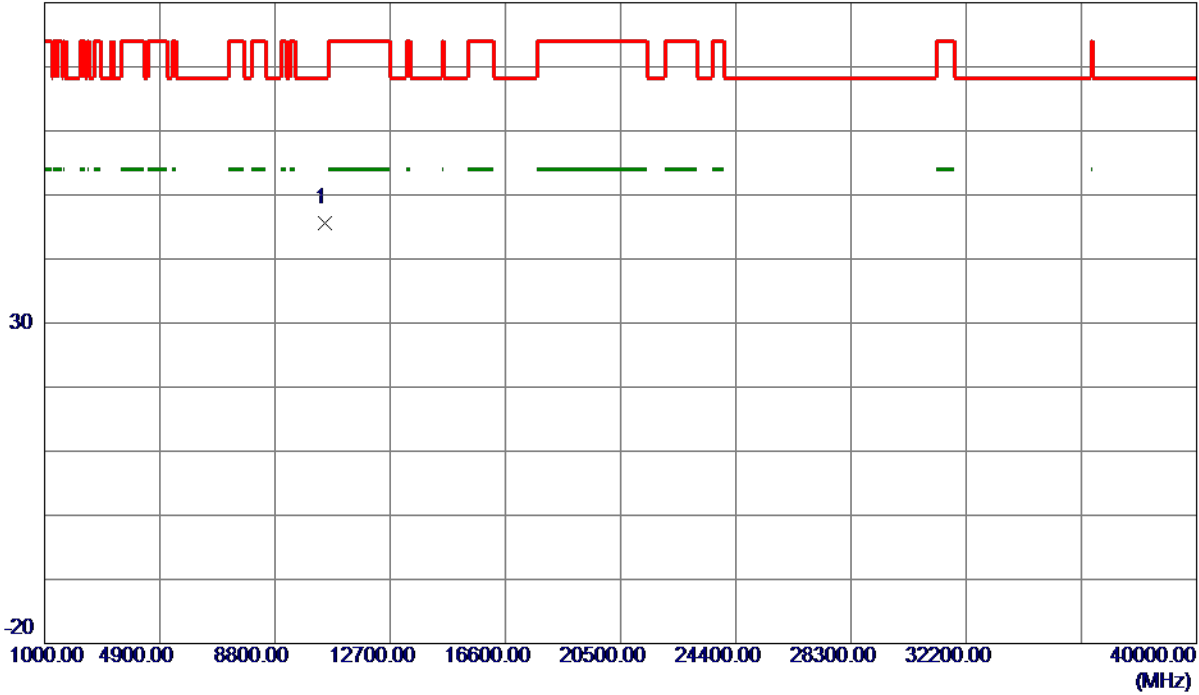

No.	Freq. MHz	Reading Level dBuV/m	Correct Factor dB	Measure ment dBuV/m	Limit dBuV/m	Margin dB	Detector	Comment
1 *	10480.1080	34.19	11.50	45.69	68.30	-22.61	Peak	

**REMARKS:**

- (1) Measurement Value = Reading Level + Correct Factor.
- (2) Margin Level = Measurement Value - Limit Value.



Orthogonal Axis	X
Test Mode	UNII-1_TX N (HT20) Mode 5180 MHz

**Vertical**

130 dBuV/m

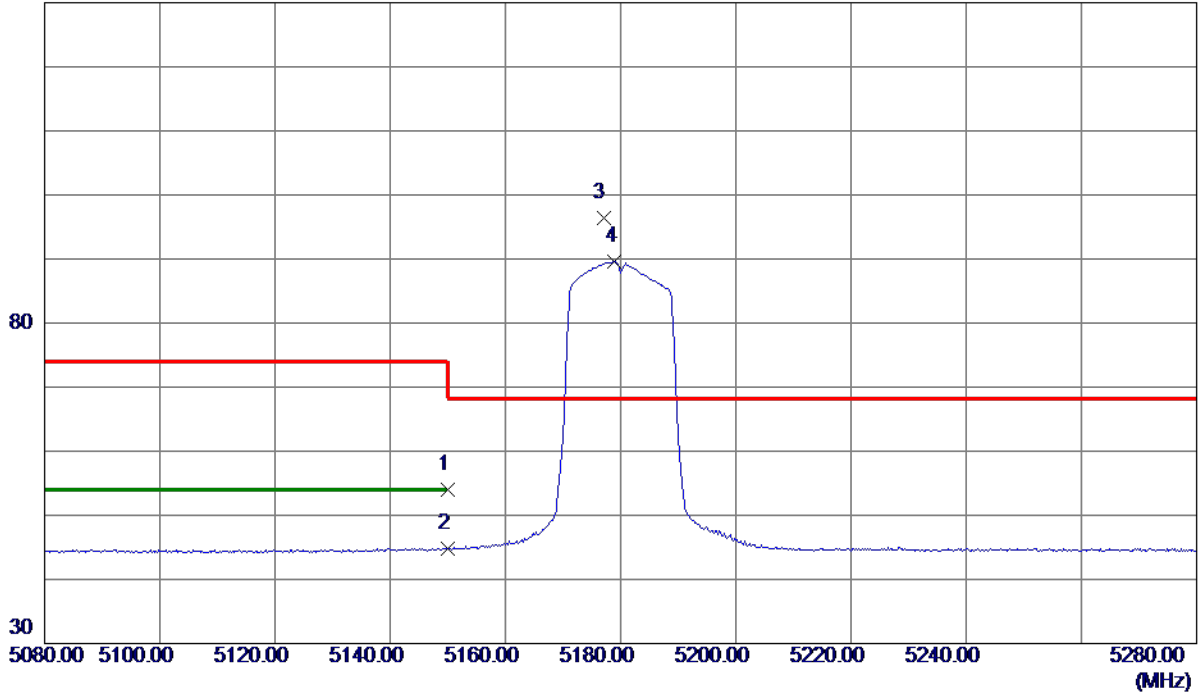

No.	Freq. MHz	Reading Level dBuV/m	Correct Factor dB	Measure ment dBuV/m	Limit dBuV/m	Margin dB	Detector	Comment
1	5150.0000	39.44	14.51	53.95	74.00	-20.05	Peak	
2	5150.0000	30.20	14.51	44.71	54.00	-9.29	AVG	
3 *	5177.0000	81.90	14.58	96.48	68.30	28.18	Peak	No Limit
4	5179.0000	75.04	14.58	89.62	999.00	-909.38	AVG	No Limit

**REMARKS:**

- (1) Measurement Value = Reading Level + Correct Factor.
- (2) Margin Level = Measurement Value - Limit Value.

Orthogonal Axis	X
Test Mode	UNII-1_TX N (HT20) Mode 5180 MHz

**Vertical**

80 dBuV/m

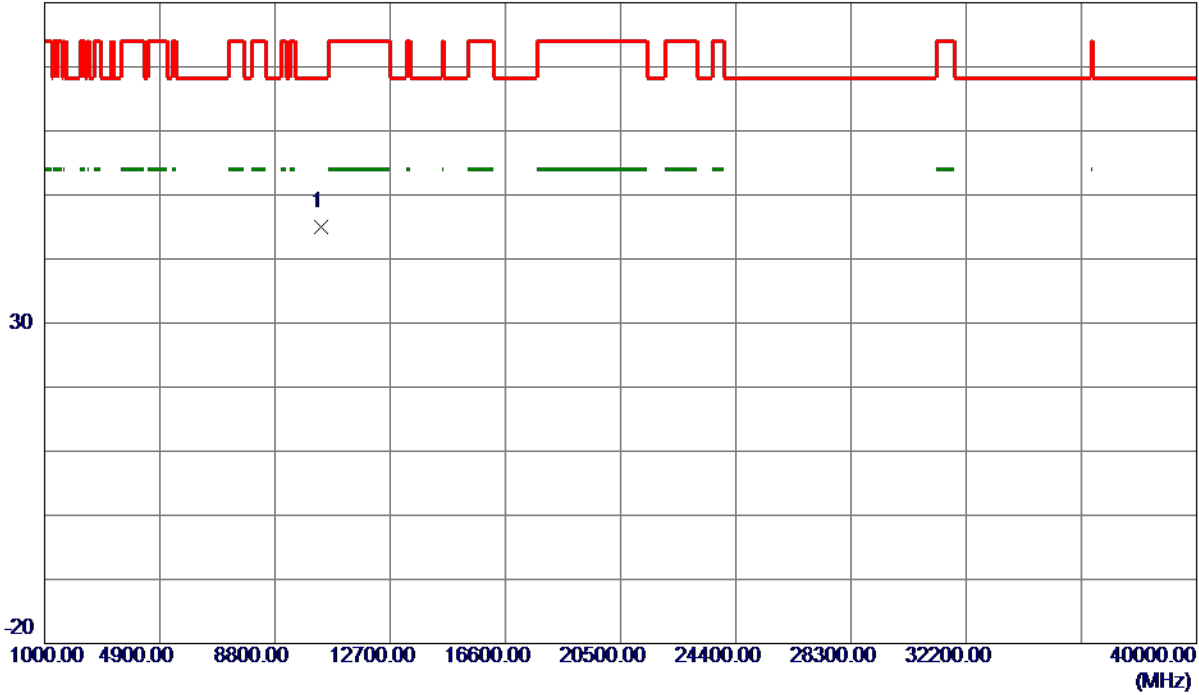

No.	Freq. MHz	Reading Level dBuV/m	Correct Factor dB	Measure ment dBuV/m	Limit dBuV/m	Margin dB	Detector	Comment
1 *	10363.1250	33.67	11.30	44.97	68.30	-23.33	Peak	

**REMARKS:**

- (1) Measurement Value = Reading Level + Correct Factor.
- (2) Margin Level = Measurement Value - Limit Value.

Orthogonal Axis	X
Test Mode	UNII-1_TX N (HT20) Mode 5180 MHz

### Horizontal

130 dBuV/m

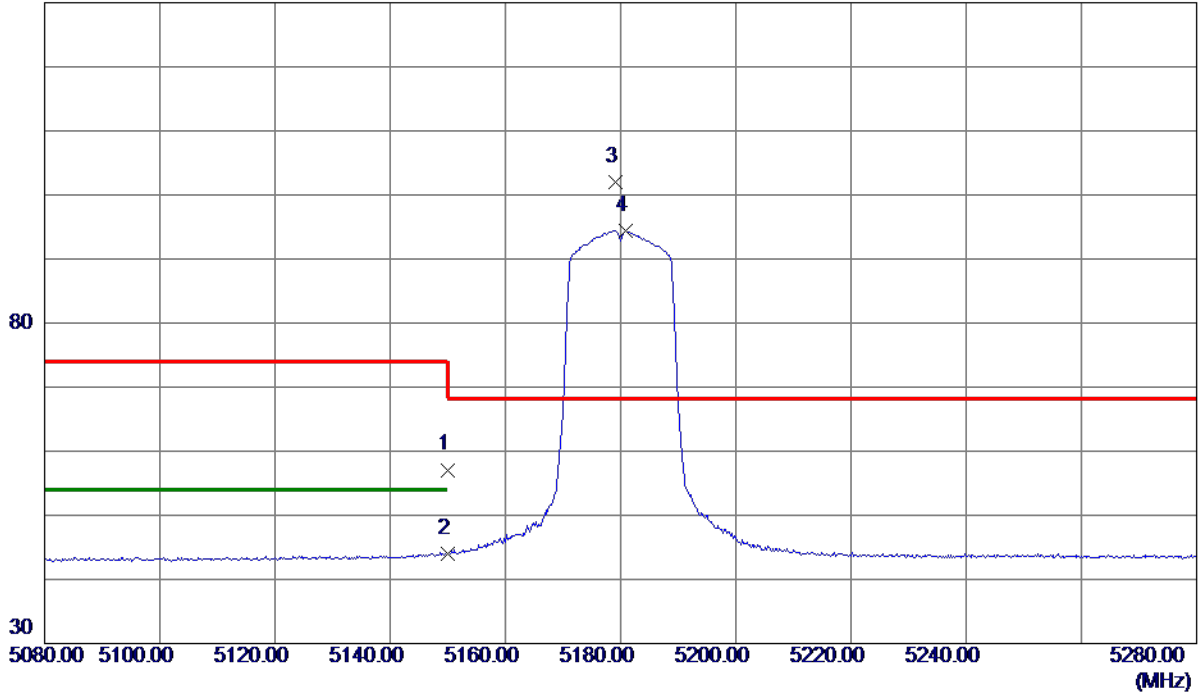

No.	Freq. MHz	Reading Level dBuV/m	Correct Factor dB	Measure ment dBuV/m	Limit dBuV/m	Margin dB	Detector	Comment
1	5150.0000	42.59	14.51	57.10	74.00	-16.90	Peak	
2	5150.0000	29.52	14.51	44.03	54.00	-9.97	AVG	
3 *	5179.2000	87.40	14.58	101.98	68.30	33.68	Peak	No Limit
4	5180.8000	79.90	14.59	94.49	999.00	-904.51	AVG	No Limit

**REMARKS:**

- (1) Measurement Value = Reading Level + Correct Factor.
- (2) Margin Level = Measurement Value - Limit Value.

Orthogonal Axis	X
Test Mode	UNII-1_TX N (HT20) Mode 5180 MHz

### Horizontal

80 dBuV/m

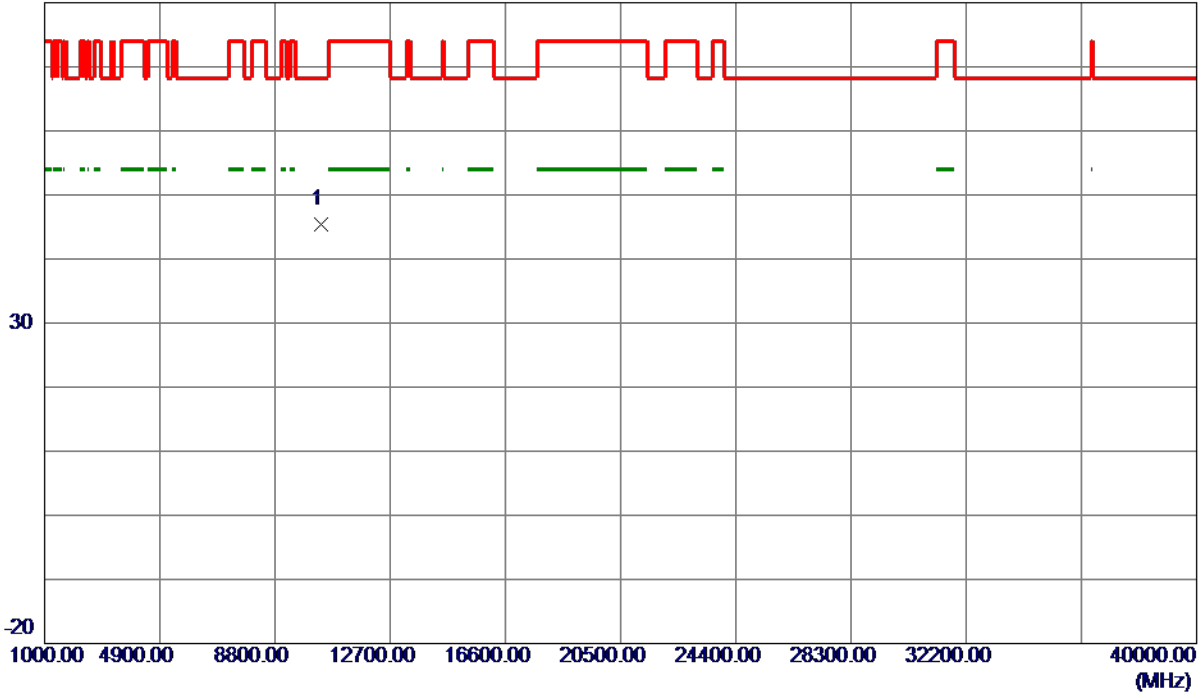

No.	Freq. MHz	Reading Level dBuV/m	Correct Factor dB	Measure ment dBuV/m	Limit dBuV/m	Margin dB	Detector	Comment
1 *	10357.8600	34.12	11.29	45.41	68.30	-22.89	Peak	

**REMARKS:**

- (1) Measurement Value = Reading Level + Correct Factor.
- (2) Margin Level = Measurement Value - Limit Value.

Orthogonal Axis	X
Test Mode	UNII-1_TX N (HT20) Mode 5200 MHz

**Vertical**

130 dBuV/m

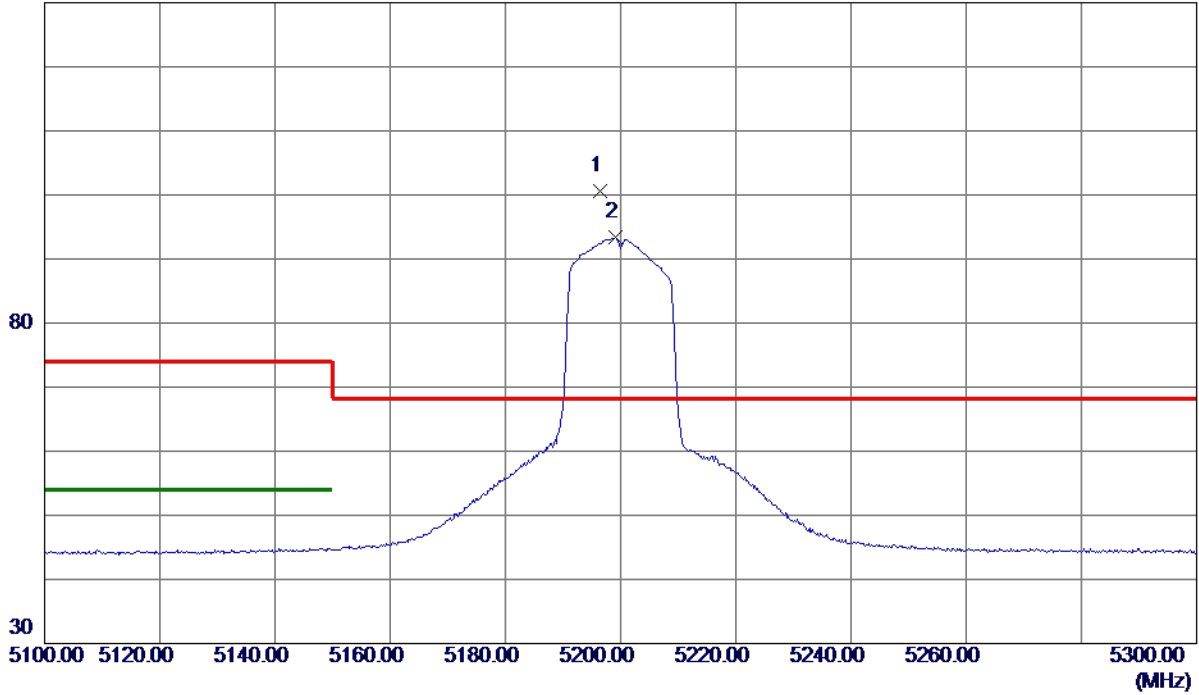

No.	Freq. MHz	Reading Level dBuV/m	Correct Factor dB	Measure ment dBuV/m	Limit dBuV/m	Margin dB	Detector	Comment
1 *	5196.4000	85.96	14.63	100.59	68.30	32.29	Peak	No Limit
2	5199.2000	78.78	14.63	93.41	999.00	-905.59	AVG	No Limit

**REMARKS:**

- (1) Measurement Value = Reading Level + Correct Factor.
- (2) Margin Level = Measurement Value - Limit Value.

Orthogonal Axis	X
Test Mode	UNII-1_TX N (HT20) Mode 5200 MHz

**Vertical**

80 dBuV/m

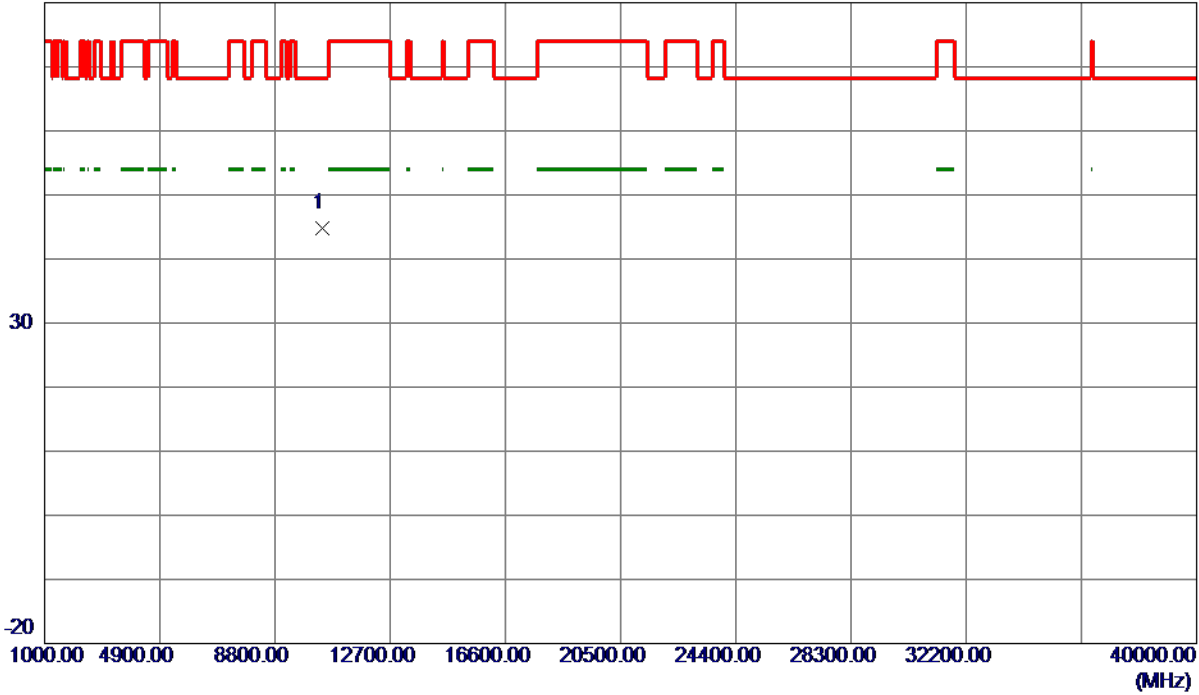

No.	Freq. MHz	Reading Level dBuV/m	Correct Factor dB	Measure ment dBuV/m	Limit dBuV/m	Margin dB	Detector	Comment
1 *	10403.4050	33.47	11.37	44.84	68.30	-23.46	Peak	

**REMARKS:**

- (1) Measurement Value = Reading Level + Correct Factor.
- (2) Margin Level = Measurement Value - Limit Value.

Orthogonal Axis	X
Test Mode	UNII-1_TX N (HT20) Mode 5200 MHz

### Horizontal

130 dBuV/m

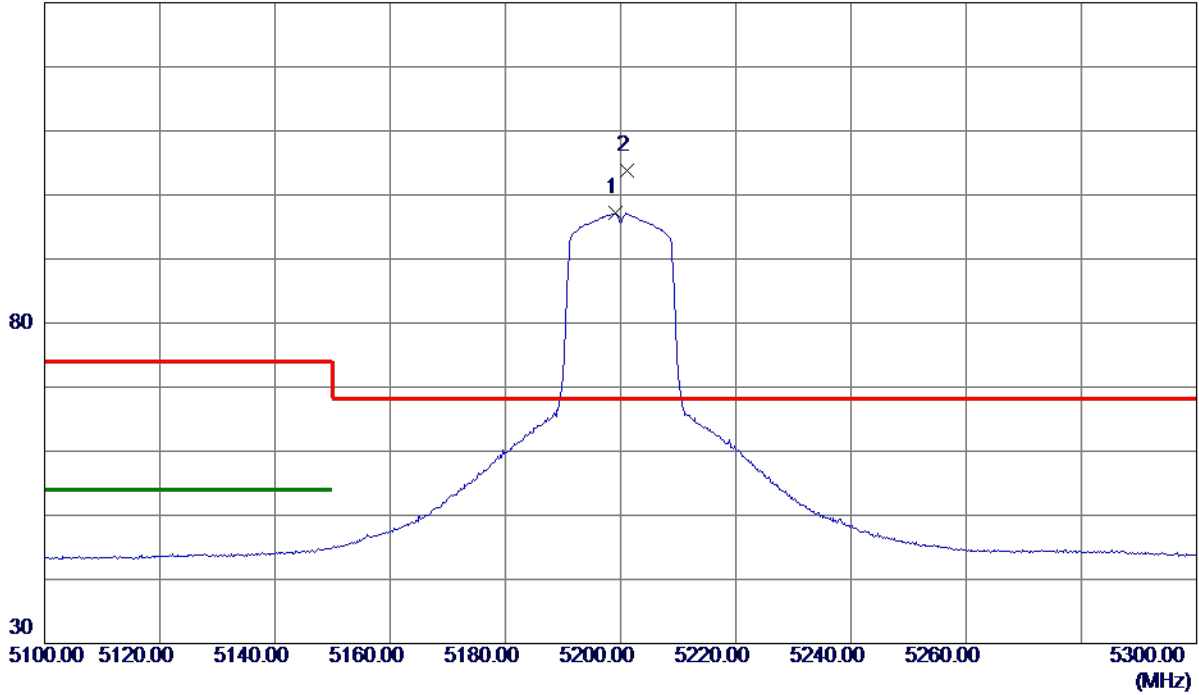

No.	Freq. MHz	Reading Level dBuV/m	Correct Factor dB	Measure ment dBuV/m	Limit dBuV/m	Margin dB	Detector	Comment
1	5199.2000	82.54	14.63	97.17	999.00	-901.83	AVG	No Limit
2 *	5201.2000	89.19	14.64	103.83	68.30	35.53	Peak	No Limit

**REMARKS:**

- (1) Measurement Value = Reading Level + Correct Factor.
- (2) Margin Level = Measurement Value - Limit Value.

Orthogonal Axis	X
Test Mode	UNII-1_TX N (HT20) Mode 5200 MHz

### Horizontal

80 dBuV/m

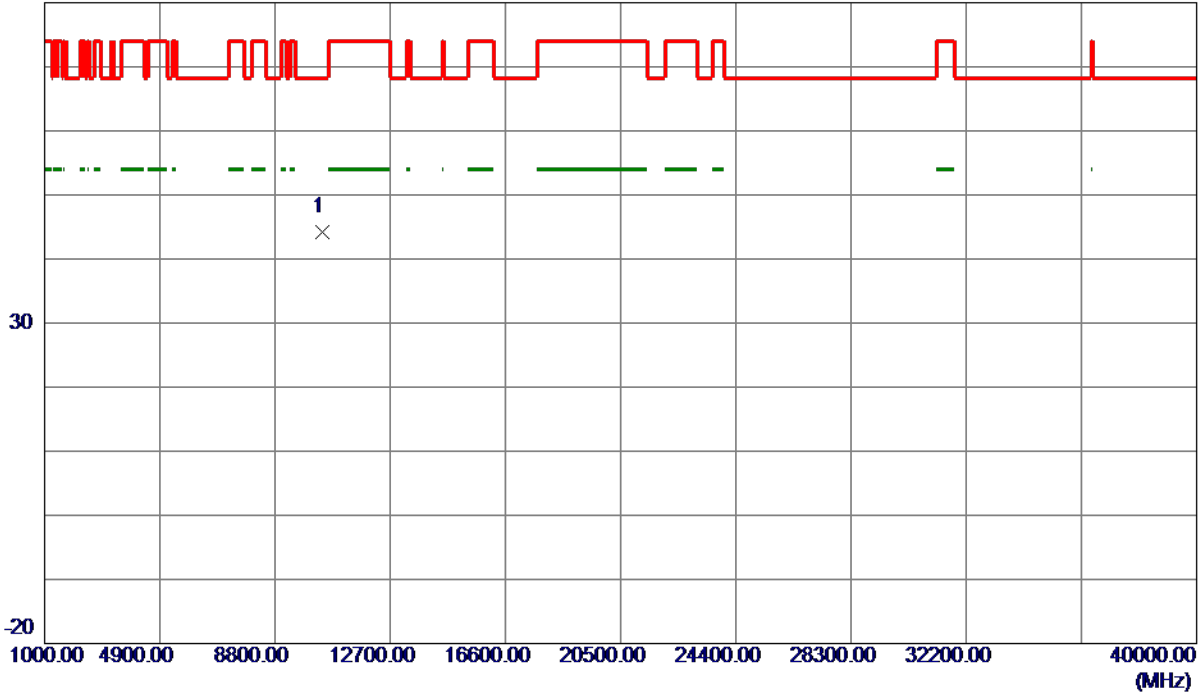

No.	Freq. MHz	Reading Level dBuV/m	Correct Factor dB	Measure ment dBuV/m	Limit dBuV/m	Margin dB	Detector	Comment
1 *	10399.6050	32.84	11.37	44.21	68.30	-24.09	Peak	

**REMARKS:**

- (1) Measurement Value = Reading Level + Correct Factor.
- (2) Margin Level = Measurement Value - Limit Value.



Orthogonal Axis	X
Test Mode	UNII-1_TX N (HT20) Mode 5240 MHz

**Vertical**

130 dBuV/m

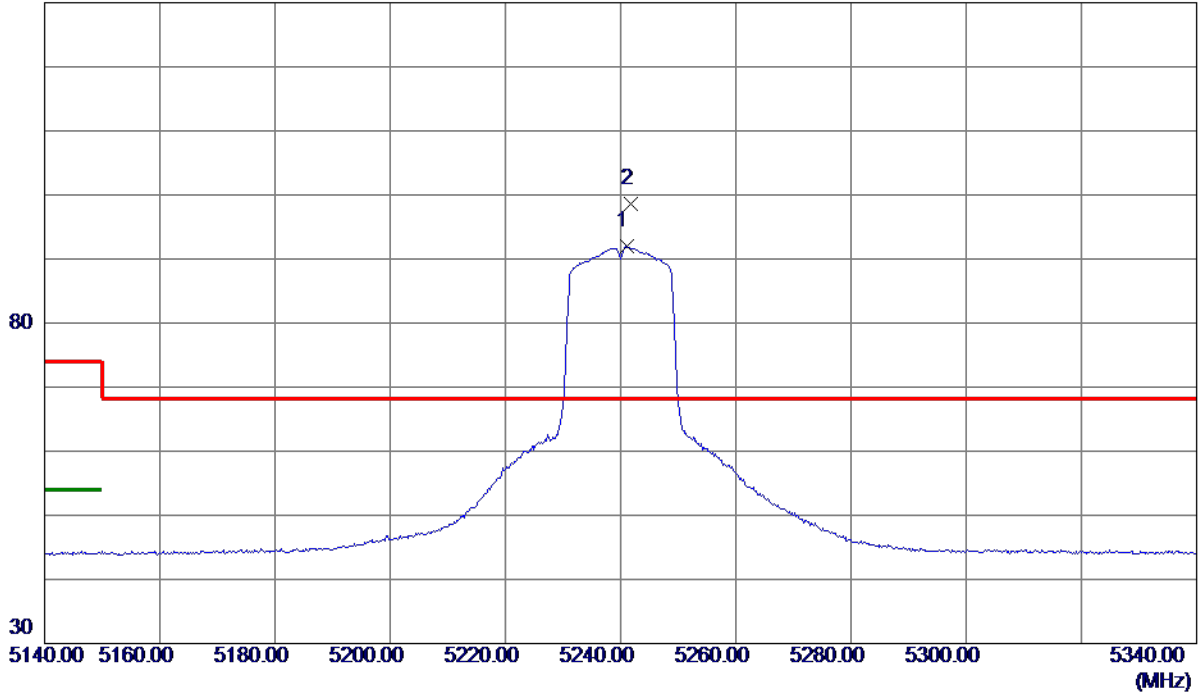

No.	Freq. MHz	Reading Level dBuV/m	Correct Factor dB	Measure ment dBuV/m	Limit dBuV/m	Margin dB	Detector	Comment
1	5241.0000	77.21	14.74	91.95	999.00	-907.05	AVG	No Limit
2 *	5241.8000	83.93	14.74	98.67	68.30	30.37	Peak	No Limit

**REMARKS:**

- (1) Measurement Value = Reading Level + Correct Factor.
- (2) Margin Level = Measurement Value - Limit Value.

Orthogonal Axis	X
Test Mode	UNII-1_TX N (HT20) Mode 5240 MHz

**Vertical**

80 dBuV/m

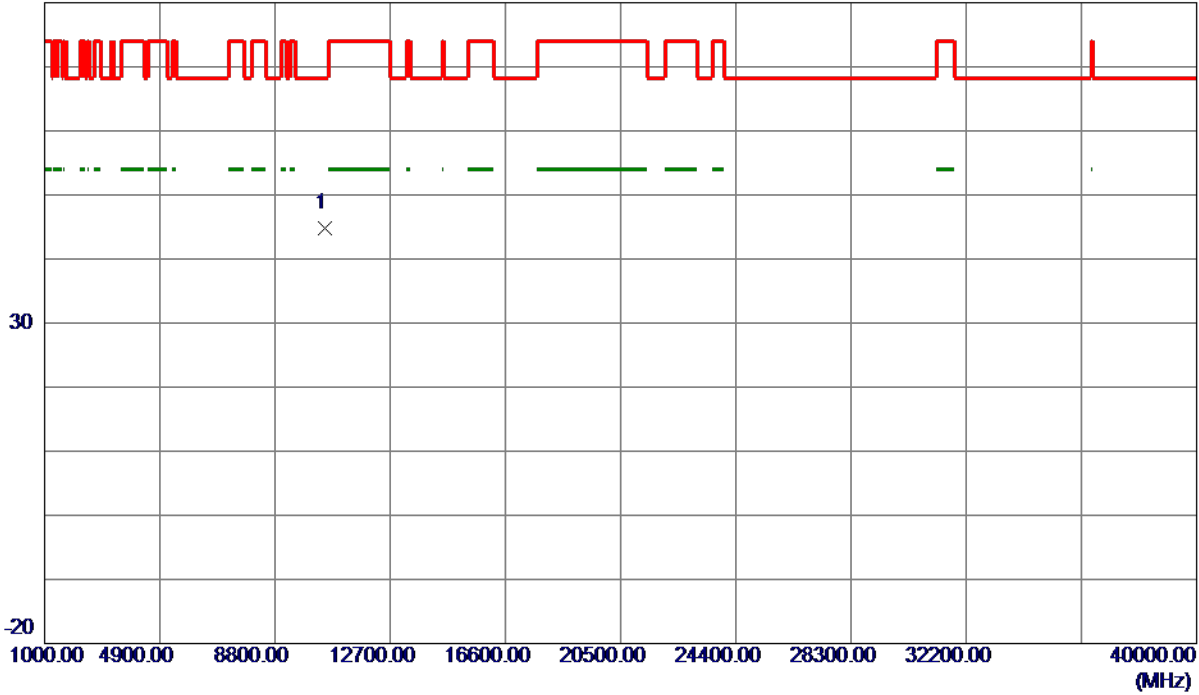

No.	Freq. MHz	Reading Level dBuV/m	Correct Factor dB	Measure ment dBuV/m	Limit dBuV/m	Margin dB	Detector	Comment
1 *	10476.4800	33.26	11.50	44.76	68.30	-23.54	Peak	

**REMARKS:**

- (1) Measurement Value = Reading Level + Correct Factor.
- (2) Margin Level = Measurement Value - Limit Value.

Orthogonal Axis	X
Test Mode	UNII-1_TX N (HT20) Mode 5240 MHz

### Horizontal

130 dBuV/m

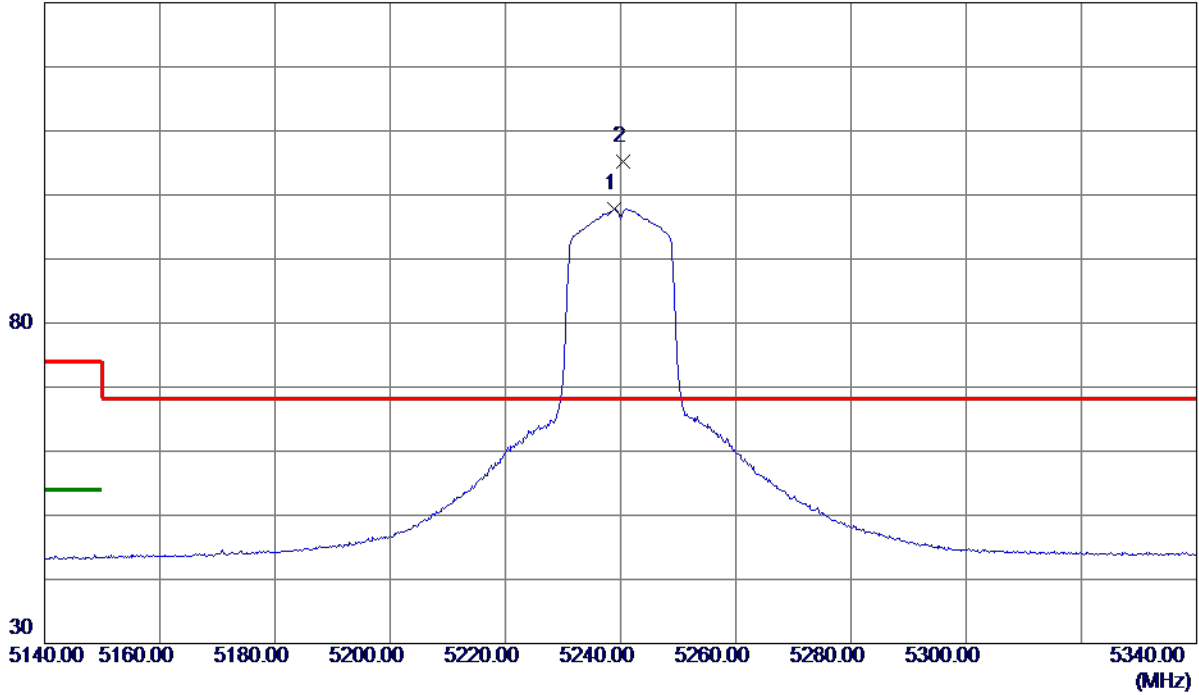

No.	Freq. MHz	Reading Level dBuV/m	Correct Factor dB	Measure ment dBuV/m	Limit dBuV/m	Margin dB	Detector	Comment
1	5238.8000	83.09	14.73	97.82	999.00	-901.18	AVG	No Limit
2 *	5240.4000	90.37	14.74	105.11	68.30	36.81	Peak	No Limit

**REMARKS:**

- (1) Measurement Value = Reading Level + Correct Factor.
- (2) Margin Level = Measurement Value - Limit Value.

Orthogonal Axis	X
Test Mode	UNII-1_TX N (HT20) Mode 5240 MHz

### Horizontal

80 dBuV/m

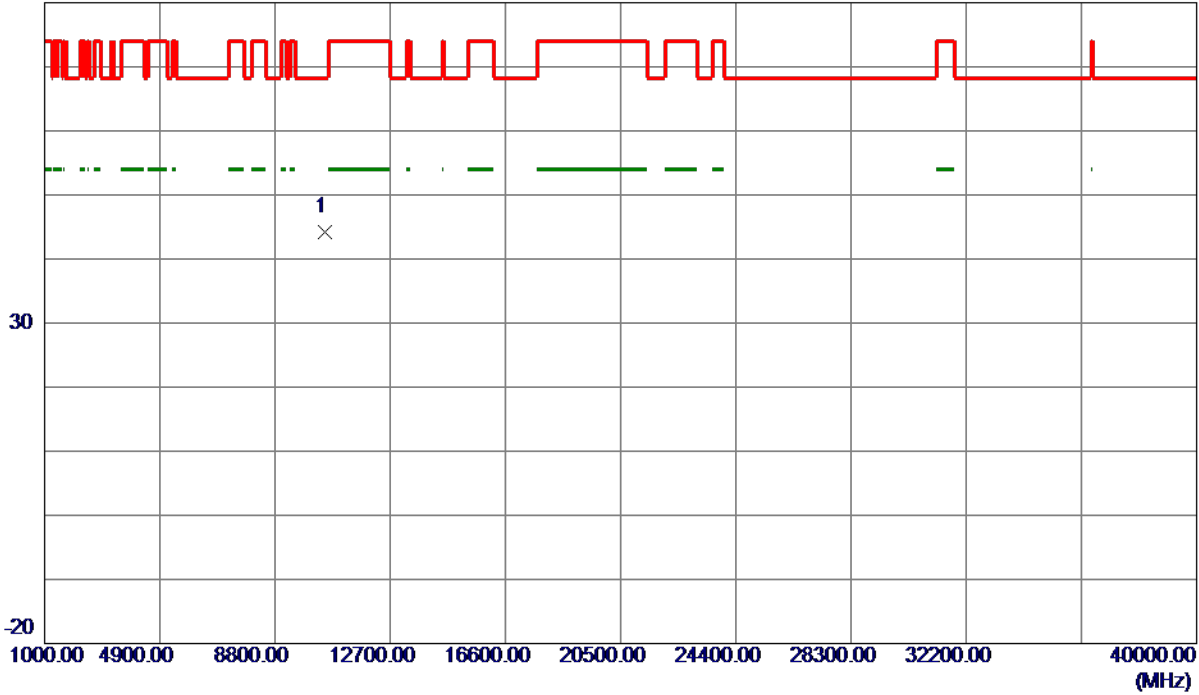

No.	Freq. MHz	Reading Level dBuV/m	Correct Factor dB	Measure ment dBuV/m	Limit dBuV/m	Margin dB	Detector	Comment
1 *	10479.0650	32.75	11.50	44.25	68.30	-24.05	Peak	

**REMARKS:**

- (1) Measurement Value = Reading Level + Correct Factor.
- (2) Margin Level = Measurement Value - Limit Value.

Orthogonal Axis	X
Test Mode	UNII-1_TX N (HT40) Mode 5190 MHz

**Vertical**

130 dBuV/m

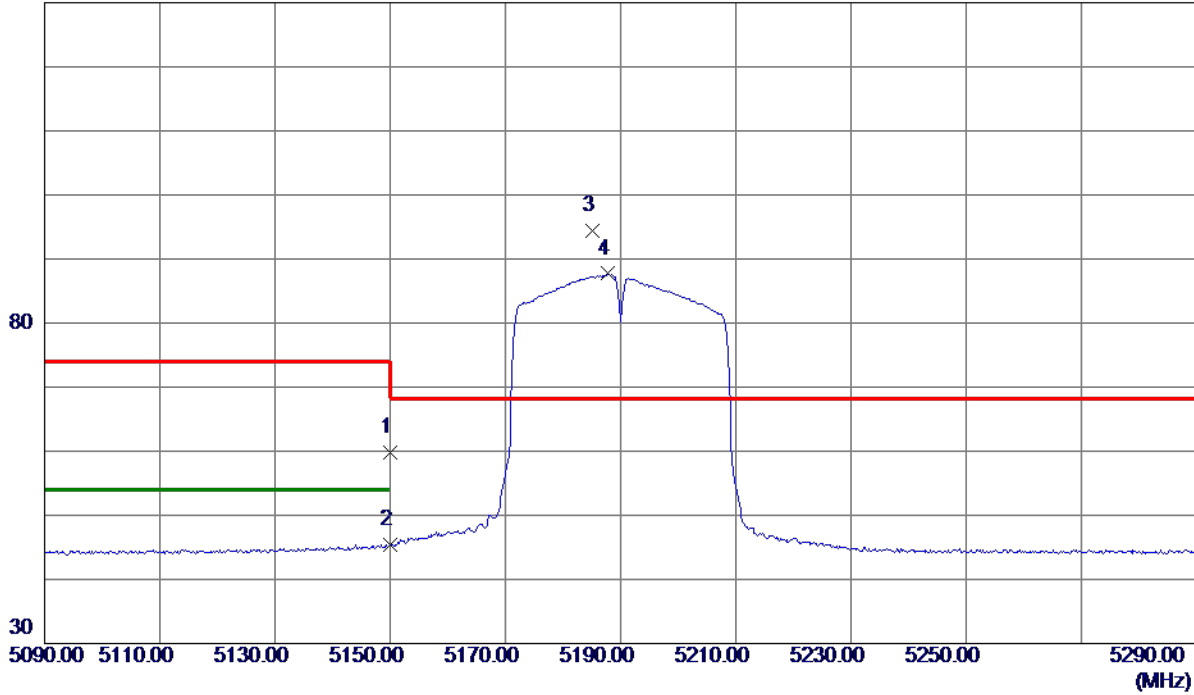

No.	Freq. MHz	Reading Level dBuV/m	Correct Factor dB	Measure ment dBuV/m	Limit dBuV/m	Margin dB	Detector	Comment
1	5150.0000	45.36	14.51	59.87	74.00	-14.13	Peak	
2	5150.0000	30.90	14.51	45.41	54.00	-8.59	AVG	
3 *	5185.2000	79.85	14.60	94.45	68.30	26.15	Peak	No Limit
4	5187.8000	73.09	14.61	87.70	999.00	-911.30	AVG	No Limit

**REMARKS:**

- (1) Measurement Value = Reading Level + Correct Factor.
- (2) Margin Level = Measurement Value - Limit Value.

Orthogonal Axis	X
Test Mode	UNII-1_TX N (HT40) Mode 5190 MHz

**Vertical**

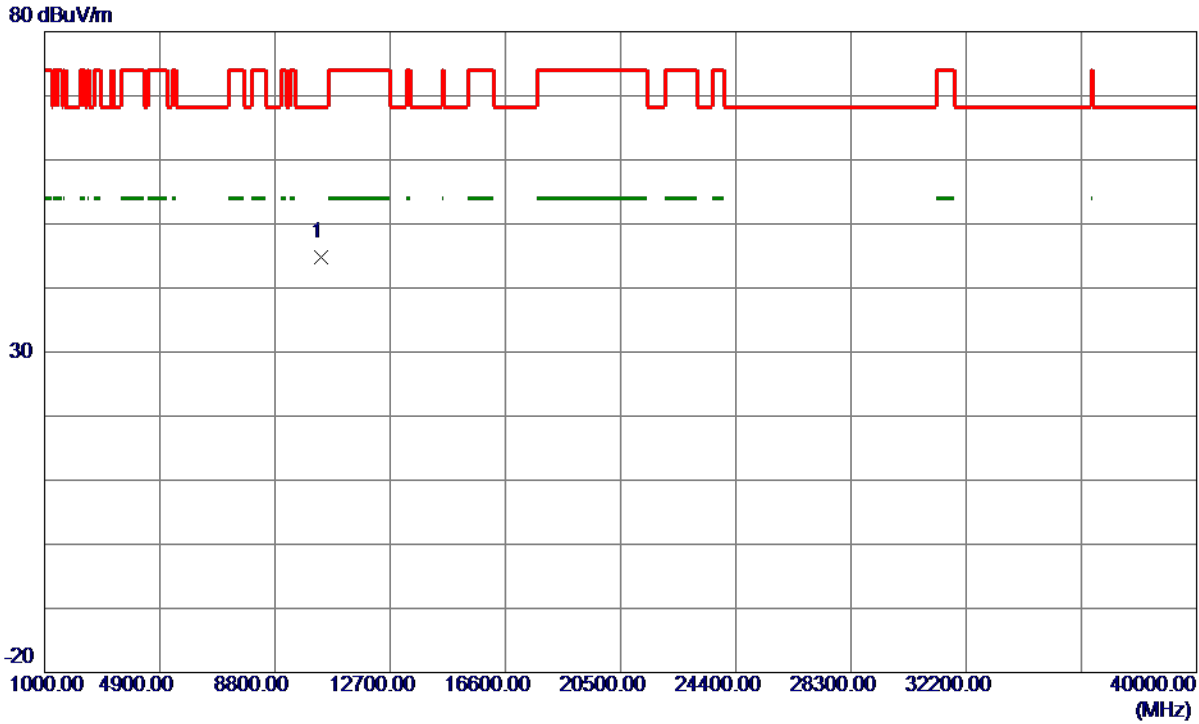

No.	Freq. MHz	Reading Level dBuV/m	Correct Factor dB	Measure ment dBuV/m	Limit dBuV/m	Margin dB	Detector	Comment
1 *	10375.8650	33.47	11.33	44.80	68.30	-23.50	Peak	

**REMARKS:**

- (1) Measurement Value = Reading Level + Correct Factor.
- (2) Margin Level = Measurement Value - Limit Value.

Orthogonal Axis	X
Test Mode	UNII-1_TX N (HT40) Mode 5190 MHz

### Horizontal

130 dBuV/m

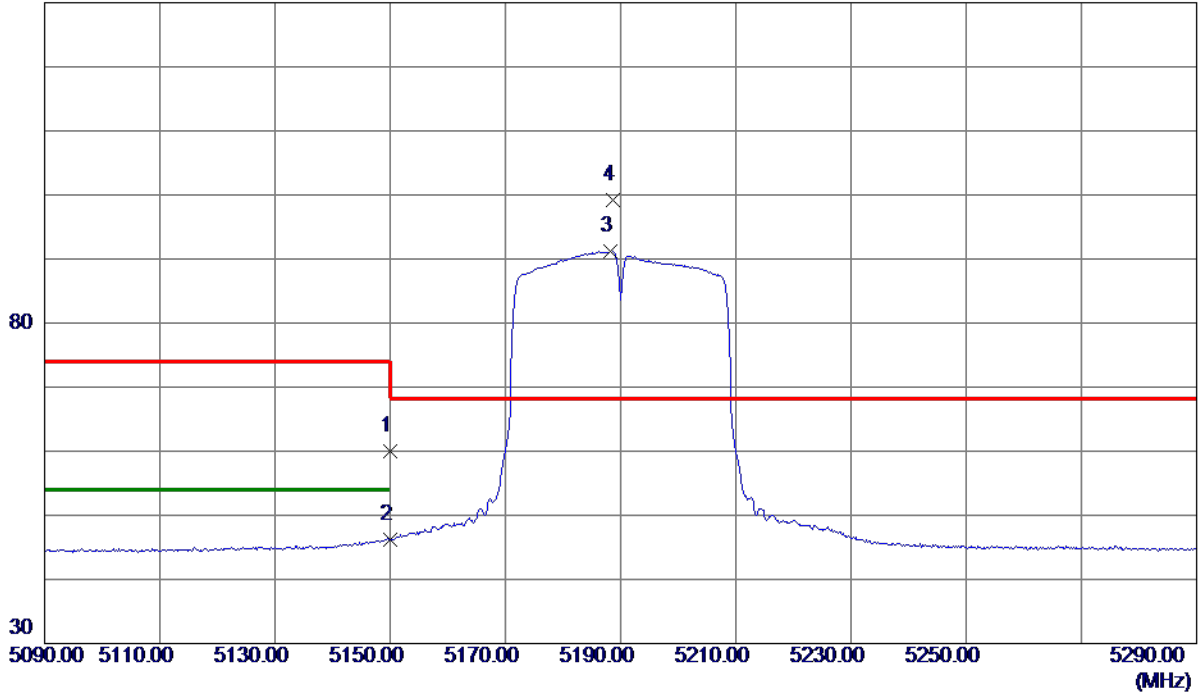

No.	Freq. MHz	Reading Level dBuV/m	Correct Factor dB	Measure ment dBuV/m	Limit dBuV/m	Margin dB	Detector	Comment
1	5150.0000	45.45	14.51	59.96	74.00	-14.04	Peak	
2	5150.0000	31.72	14.51	46.23	54.00	-7.77	AVG	
3	5188.2000	76.53	14.61	91.14	999.00	-907.86	AVG	No Limit
4 *	5188.6000	84.64	14.61	99.25	68.30	30.95	Peak	No Limit

**REMARKS:**

- (1) Measurement Value = Reading Level + Correct Factor.
- (2) Margin Level = Measurement Value - Limit Value.

Orthogonal Axis	X
Test Mode	UNII-1_TX N (HT40) Mode 5190 MHz

### Horizontal

80 dBuV/m

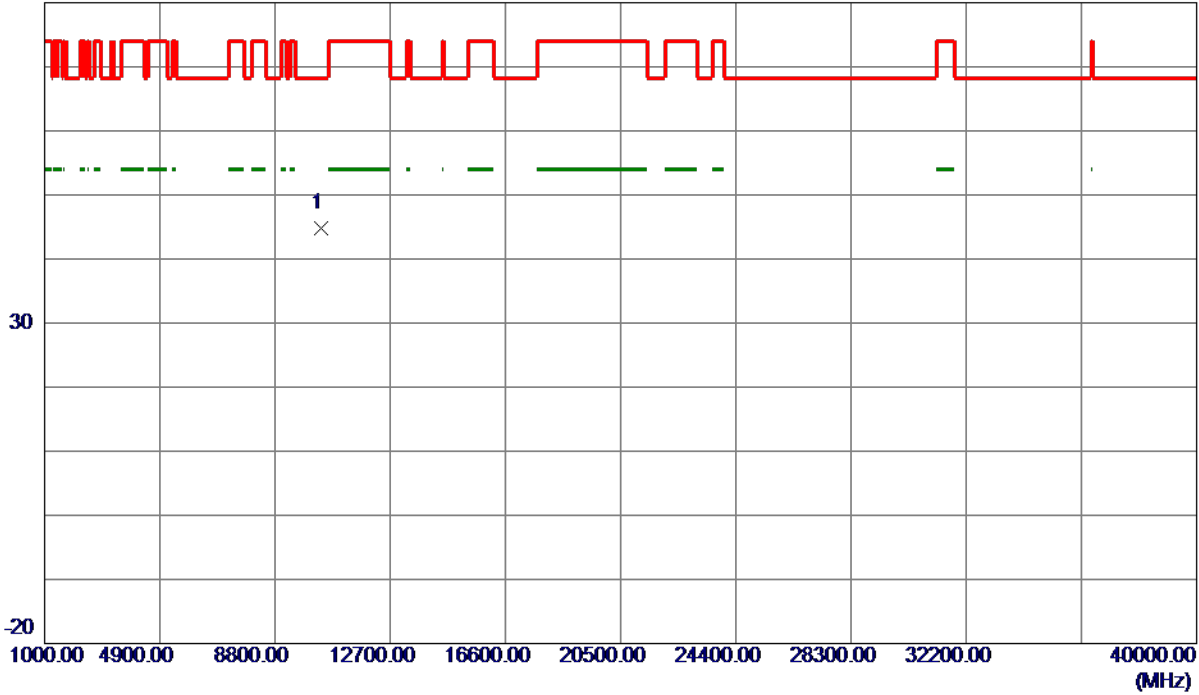

No.	Freq. MHz	Reading Level dBuV/m	Correct Factor dB	Measure ment dBuV/m	Limit dBuV/m	Margin dB	Detector	Comment
1 *	10380.4700	33.38	11.33	44.71	68.30	-23.59	Peak	

**REMARKS:**

- (1) Measurement Value = Reading Level + Correct Factor.
- (2) Margin Level = Measurement Value - Limit Value.



Orthogonal Axis	X
Test Mode	UNII-1_TX N (HT40) Mode 5230 MHz

**Vertical**

130 dBuV/m

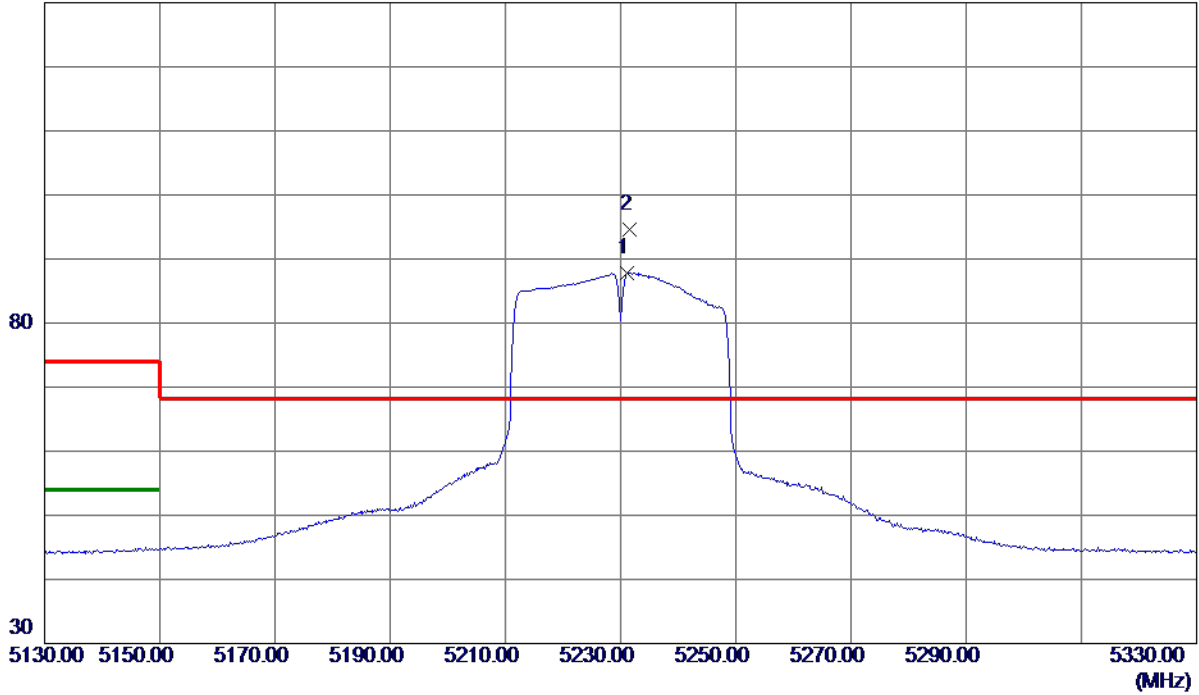

No.	Freq. MHz	Reading Level dBuV/m	Correct Factor dB	Measure ment dBuV/m	Limit dBuV/m	Margin dB	Detector	Comment
1	5231.2000	73.15	14.71	87.86	999.00	-911.14	AVG	No Limit
2 *	5231.6000	79.94	14.72	94.66	68.30	26.36	Peak	No Limit

**REMARKS:**

- (1) Measurement Value = Reading Level + Correct Factor.
- (2) Margin Level = Measurement Value - Limit Value.

Orthogonal Axis	X
Test Mode	UNII-1_TX N (HT40) Mode 5230 MHz

**Vertical**

80 dBuV/m

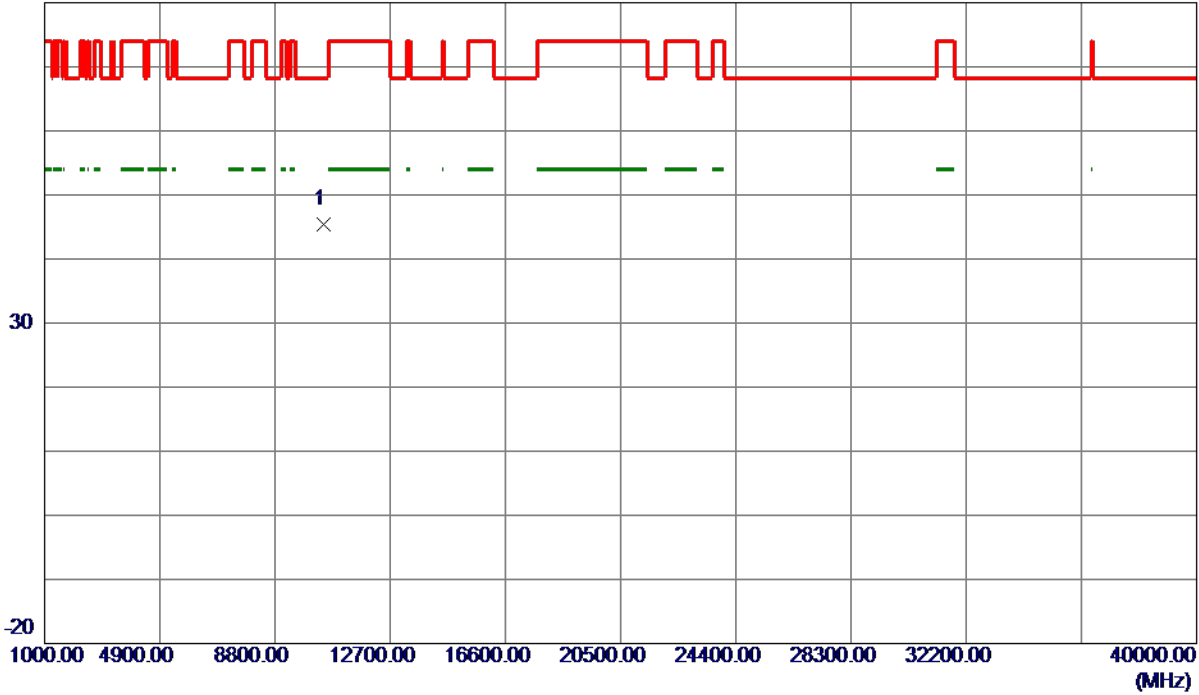

No.	Freq. MHz	Reading Level dBuV/m	Correct Factor dB	Measure ment dBuV/m	Limit dBuV/m	Margin dB	Detector	Comment
1 *	10464.7300	33.98	11.48	45.46	68.30	-22.84	Peak	

**REMARKS:**

- (1) Measurement Value = Reading Level + Correct Factor.
- (2) Margin Level = Measurement Value - Limit Value.

Orthogonal Axis	X
Test Mode	UNII-1_TX N (HT40) Mode 5230 MHz

### Horizontal

130 dBuV/m

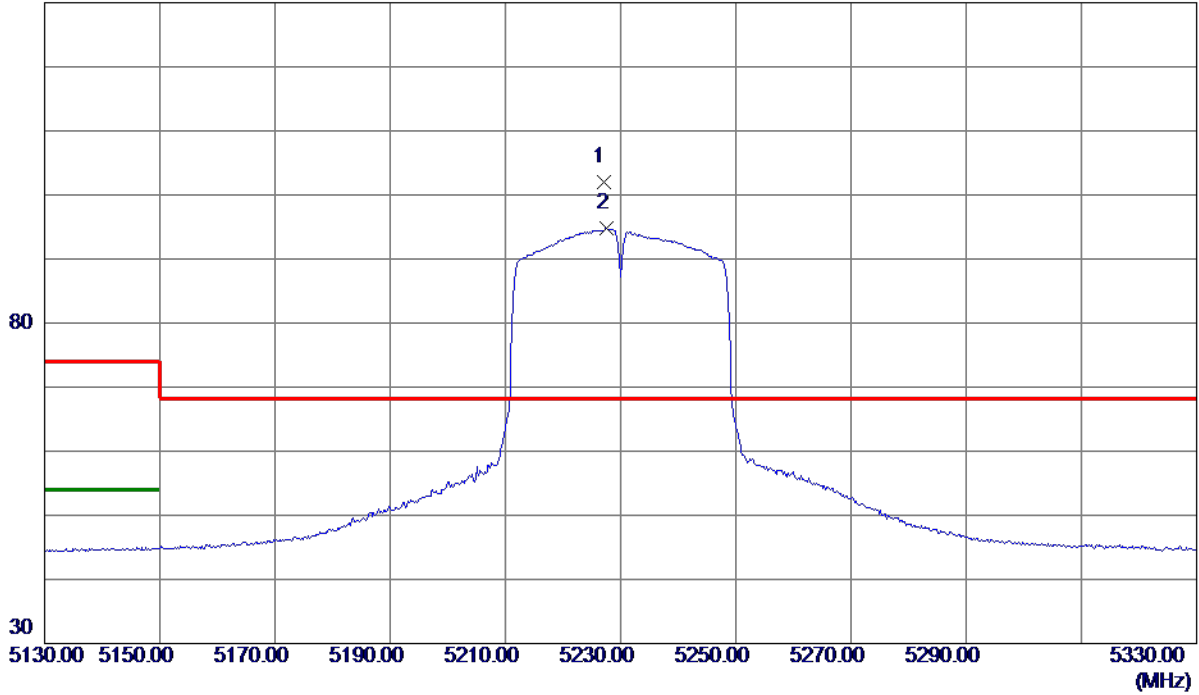

No.	Freq. MHz	Reading Level dBuV/m	Correct Factor dB	Measure ment dBuV/m	Limit dBuV/m	Margin dB	Detector	Comment
1 *	5227.0000	87.39	14.70	102.09	68.30	33.79	Peak	No Limit
2	5227.6000	80.05	14.71	94.76	999.00	-904.24	AVG	No Limit

**REMARKS:**

- (1) Measurement Value = Reading Level + Correct Factor.
- (2) Margin Level = Measurement Value - Limit Value.

Orthogonal Axis	X
Test Mode	UNII-1_TX N (HT40) Mode 5230 MHz

### Horizontal

80 dBuV/m

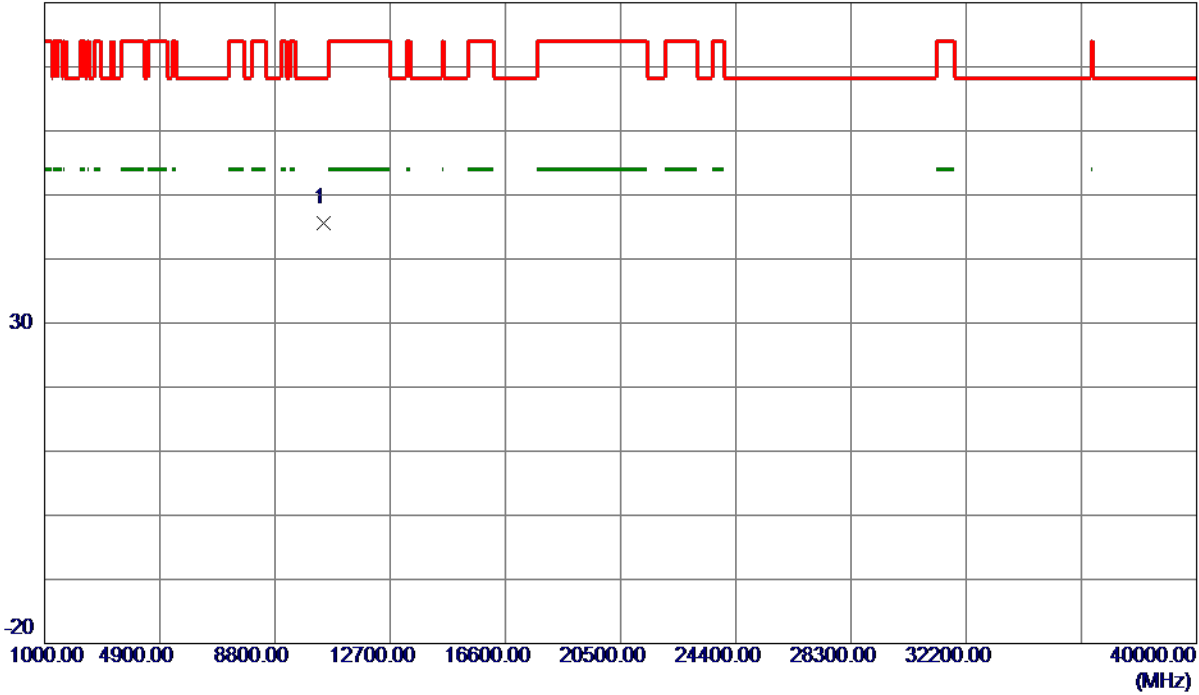

No.	Freq. MHz	Reading Level dBuV/m	Correct Factor dB	Measure ment dBuV/m	Limit dBuV/m	Margin dB	Detector	Comment
1 *	10463.7650	34.20	11.47	45.67	68.30	-22.63	Peak	

**REMARKS:**

- (1) Measurement Value = Reading Level + Correct Factor.
- (2) Margin Level = Measurement Value - Limit Value.

Orthogonal Axis	X
Test Mode	UNII-2A_TX A Mode 5260 MHz

**Vertical**

130 dBuV/m

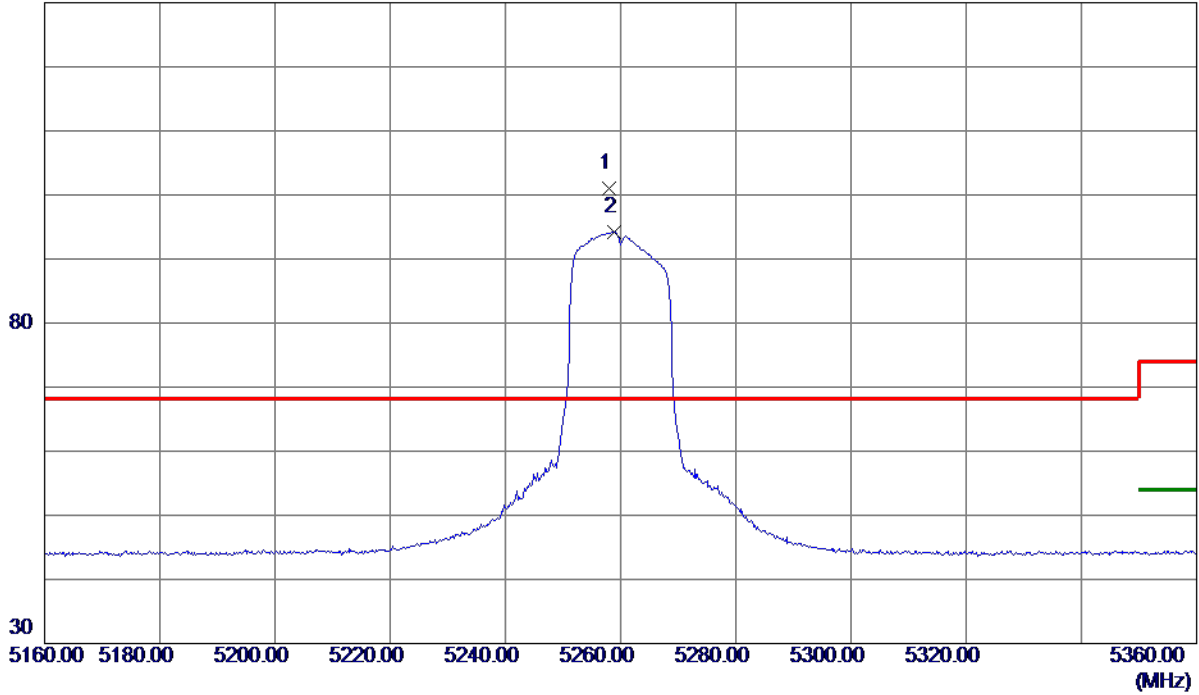

No.	Freq. MHz	Reading Level dBuV/m	Correct Factor dB	Measure ment dBuV/m	Limit dBuV/m	Margin dB	Detector	Comment
1 *	5258.0000	86.13	14.78	100.91	68.30	32.61	Peak	No Limit
2	5258.8000	79.48	14.78	94.26	999.00	-904.74	AVG	No Limit

**REMARKS:**

- (1) Measurement Value = Reading Level + Correct Factor.
- (2) Margin Level = Measurement Value - Limit Value.

Orthogonal Axis	X
Test Mode	UNII-2A_TX A Mode 5260 MHz

**Vertical**

80 dBuV/m

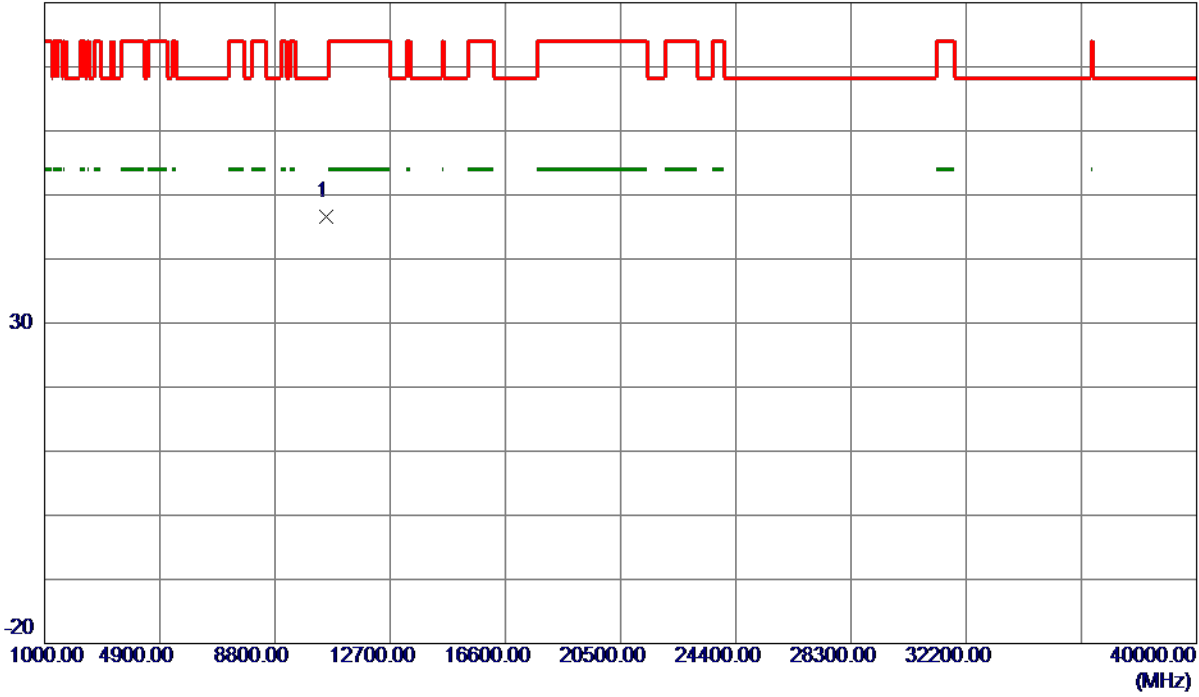

No.	Freq. MHz	Reading Level dBuV/m	Correct Factor dB	Measure ment dBuV/m	Limit dBuV/m	Margin dB	Detector	Comment
1 *	10519.5220	35.13	11.54	46.67	68.30	-21.63	Peak	

**REMARKS:**

- (1) Measurement Value = Reading Level + Correct Factor.
- (2) Margin Level = Measurement Value - Limit Value.

Orthogonal Axis	X
Test Mode	UNII-2A_TX A Mode 5260 MHz

### Horizontal

130 dBuV/m

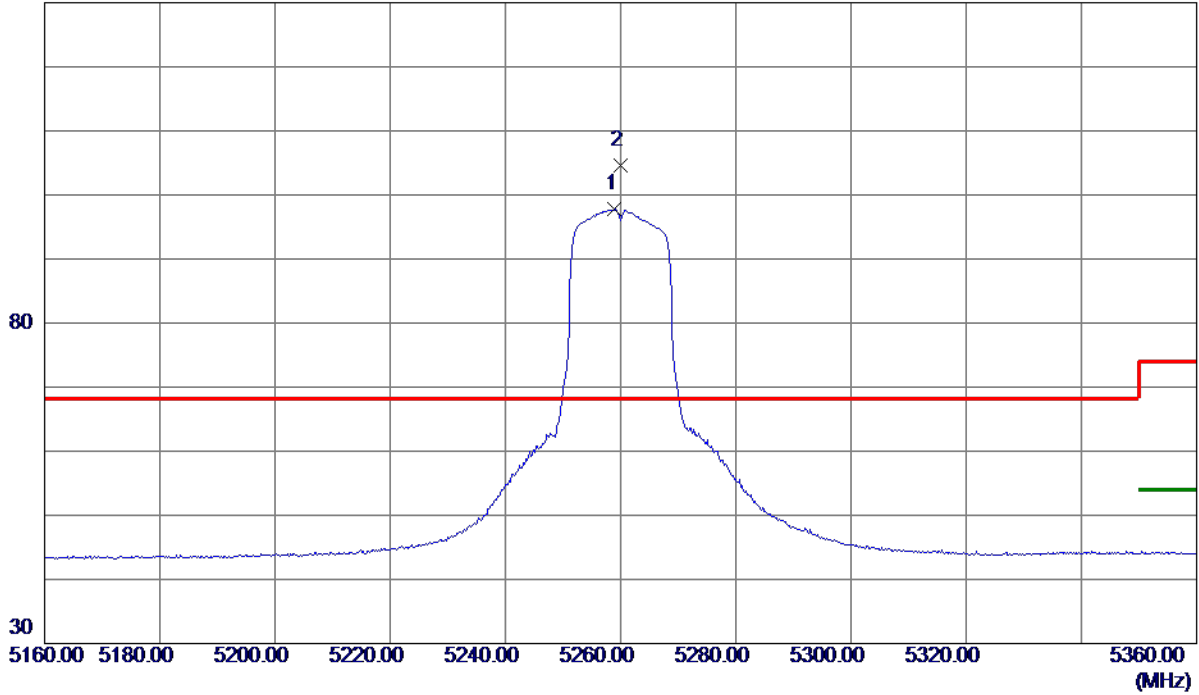

No.	Freq. MHz	Reading Level dBuV/m	Correct Factor dB	Measure ment dBuV/m	Limit dBuV/m	Margin dB	Detector	Comment
1	5259.0000	83.01	14.79	97.80	999.00	-901.20	AVG	No Limit
2 *	5260.0000	89.80	14.79	104.59	68.30	36.29	Peak	No Limit

**REMARKS:**

- (1) Measurement Value = Reading Level + Correct Factor.
- (2) Margin Level = Measurement Value - Limit Value.

Orthogonal Axis	X
Test Mode	UNII-2A_TX A Mode 5260 MHz

### Horizontal

80 dBuV/m

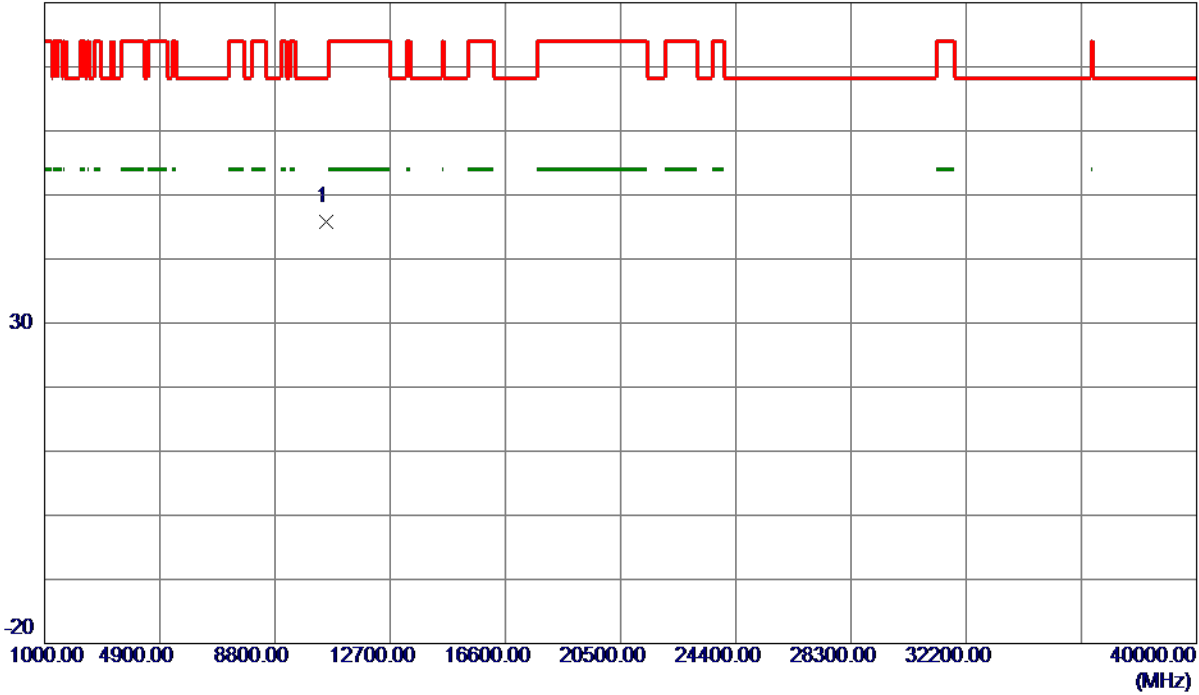

No.	Freq. MHz	Reading Level dBuV/m	Correct Factor dB	Measure ment dBuV/m	Limit dBuV/m	Margin dB	Detector	Comment
1 *	10520.3640	34.20	11.54	45.74	68.30	-22.56	Peak	

**REMARKS:**

- (1) Measurement Value = Reading Level + Correct Factor.
- (2) Margin Level = Measurement Value - Limit Value.



Orthogonal Axis	X
Test Mode	UNII-2A_TX A Mode 5300 MHz

**Vertical**

130 dBuV/m

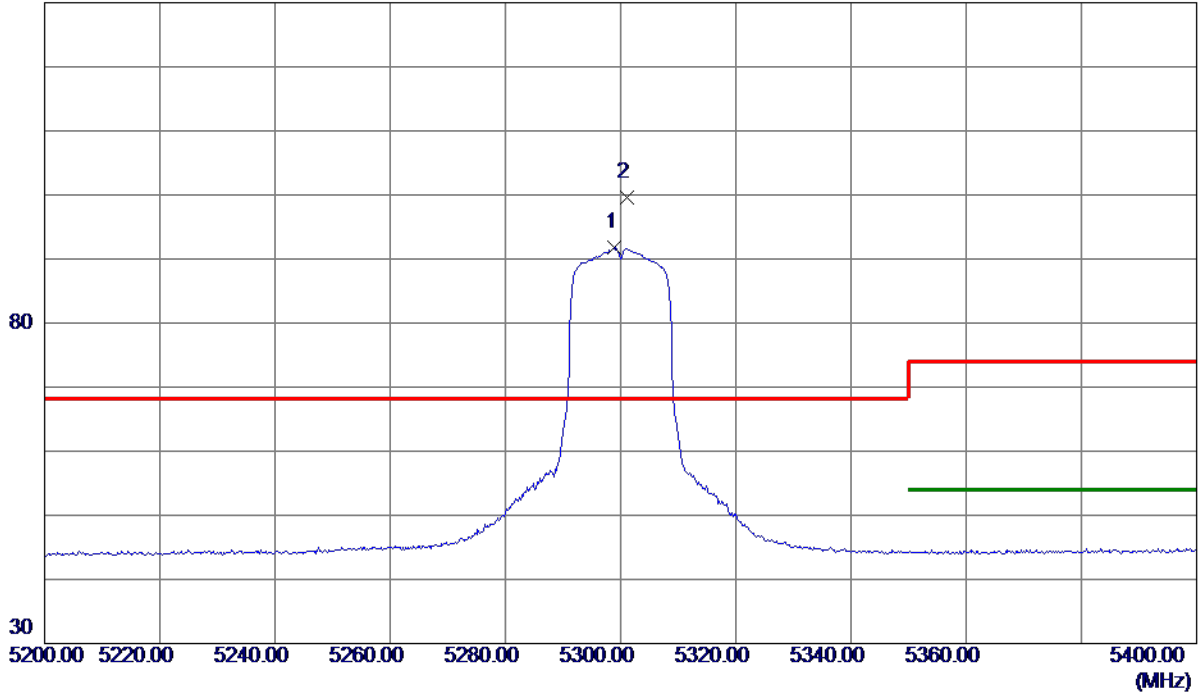

No.	Freq. MHz	Reading Level dBuV/m	Correct Factor dB	Measure ment dBuV/m	Limit dBuV/m	Margin dB	Detector	Comment
1	5299.0000	76.85	14.89	91.74	999.00	-907.26	AVG	No Limit
2 *	5301.2000	84.77	14.89	99.66	68.30	31.36	Peak	No Limit

**REMARKS:**

- (1) Measurement Value = Reading Level + Correct Factor.
- (2) Margin Level = Measurement Value - Limit Value.

Orthogonal Axis	X
Test Mode	UNII-2A_TX A Mode 5300 MHz

**Vertical**

80 dBuV/m

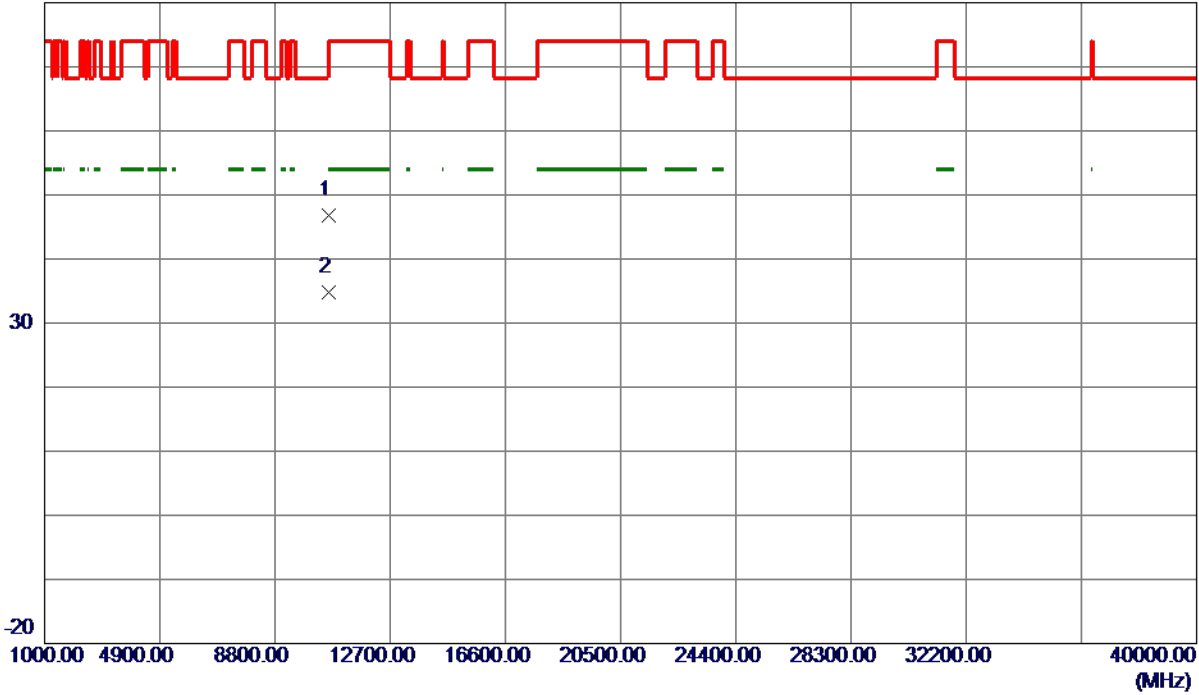

No.	Freq. MHz	Reading Level dBuV/m	Correct Factor dB	Measure ment dBuV/m	Limit dBuV/m	Margin dB	Detector	Comment
1	10600.2330	35.16	11.55	46.71	74.00	-27.29	Peak	
2 *	10600.3200	23.24	11.55	34.79	54.00	-19.21	AVG	

**REMARKS:**

- (1) Measurement Value = Reading Level + Correct Factor.
- (2) Margin Level = Measurement Value - Limit Value.

Orthogonal Axis	X
Test Mode	UNII-2A_TX A Mode 5300 MHz

### Horizontal

130 dBuV/m

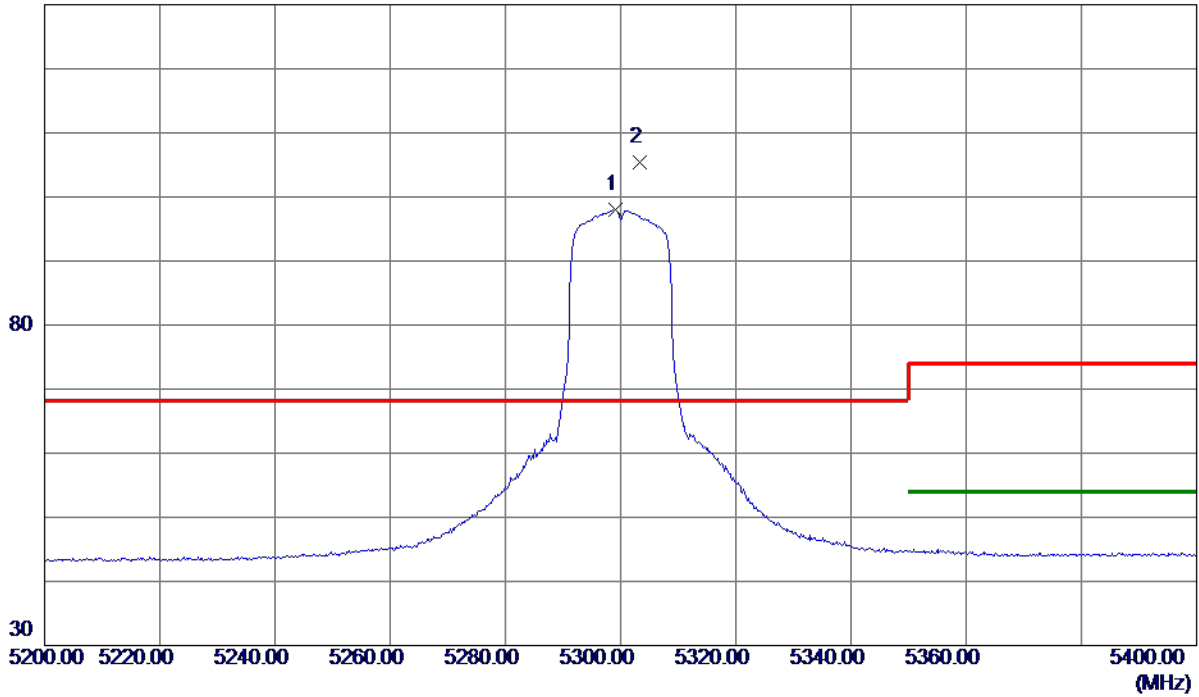

No.	Freq. MHz	Reading Level dBuV/m	Correct Factor dB	Measure ment dBuV/m	Limit dBuV/m	Margin dB	Detector	Comment
1	5299.2000	83.18	14.89	98.07	999.00	-900.93	AVG	No Limit
2 *	5303.4000	90.48	14.90	105.38	68.30	37.08	Peak	No Limit

**REMARKS:**

- (1) Measurement Value = Reading Level + Correct Factor.
- (2) Margin Level = Measurement Value - Limit Value.

Orthogonal Axis	X
Test Mode	UNII-2A_TX A Mode 5300 MHz

### Horizontal

80 dBuV/m

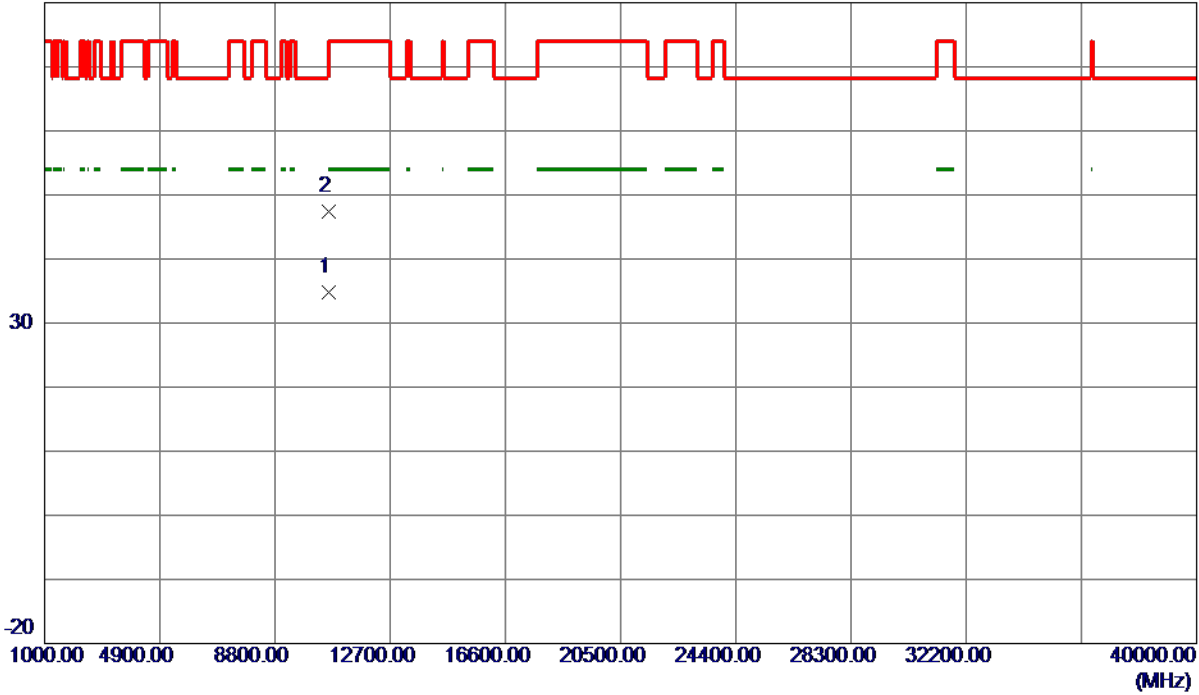

No.	Freq. MHz	Reading Level dBuV/m	Correct Factor dB	Measure ment dBuV/m	Limit dBuV/m	Margin dB	Detector	Comment
1 *	10600.4290	23.24	11.55	34.79	54.00	-19.21	AVG	
2	10600.4370	35.92	11.55	47.47	74.00	-26.53	Peak	

**REMARKS:**

- (1) Measurement Value = Reading Level + Correct Factor.
- (2) Margin Level = Measurement Value - Limit Value.

Orthogonal Axis	X
Test Mode	UNII-2A_TX A Mode 5320 MHz

**Vertical**

130 dBuV/m

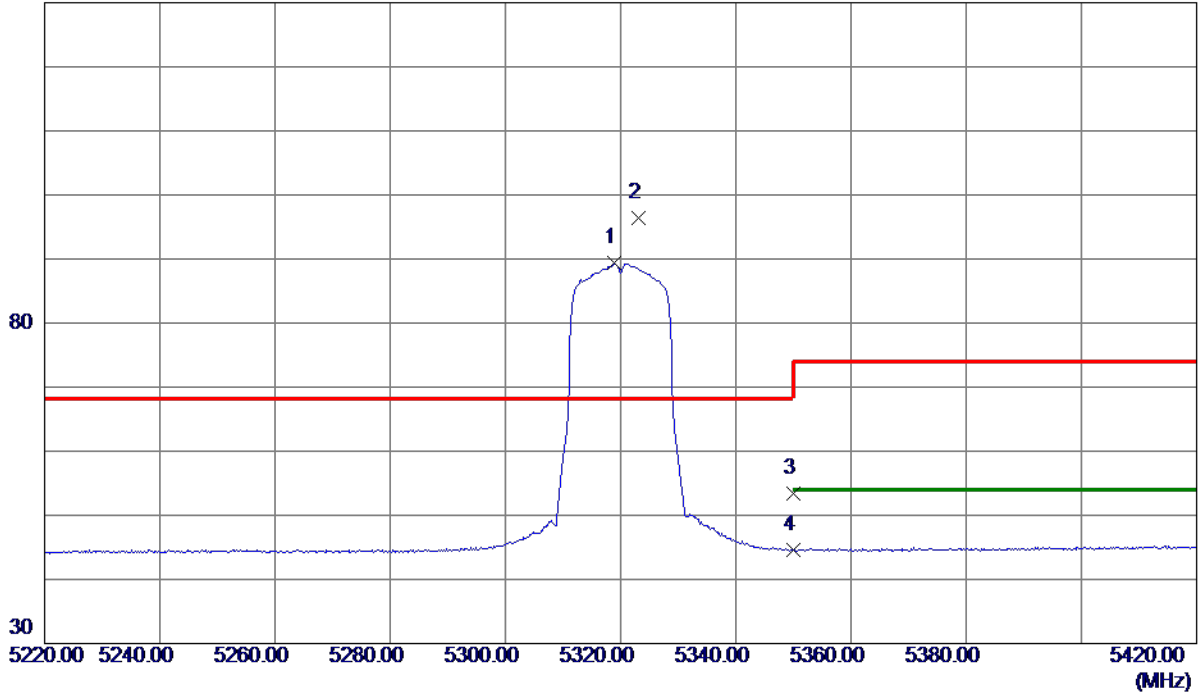

No.	Freq. MHz	Reading Level dBuV/m	Correct Factor dB	Measure ment dBuV/m	Limit dBuV/m	Margin dB	Detector	Comment
1	5318.8000	74.38	14.94	89.32	999.00	-909.68	AVG	No Limit
2 *	5323.2000	81.43	14.95	96.38	68.30	28.08	Peak	No Limit
3	5350.0000	38.43	15.02	53.45	74.00	-20.55	Peak	
4	5350.0000	29.59	15.02	44.61	54.00	-9.39	AVG	

**REMARKS:**

- (1) Measurement Value = Reading Level + Correct Factor.
- (2) Margin Level = Measurement Value - Limit Value.

Orthogonal Axis	X
Test Mode	UNII-2A_TX A Mode 5320 MHz

**Vertical**

80 dBuV/m

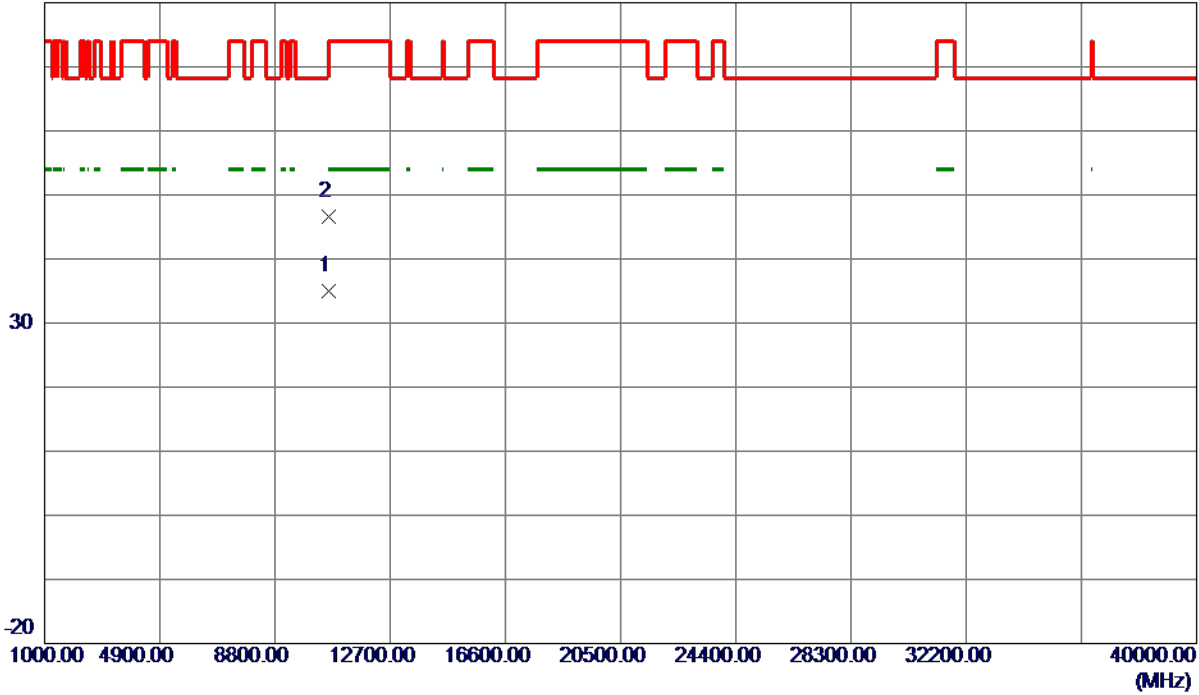

No.	Freq. MHz	Reading Level dBuV/m	Correct Factor dB	Measure ment dBuV/m	Limit dBuV/m	Margin dB	Detector	Comment
1 *	10639.7870	23.50	11.56	35.06	54.00	-18.94	AVG	
2	10640.4880	35.00	11.56	46.56	74.00	-27.44	Peak	

**REMARKS:**

- (1) Measurement Value = Reading Level + Correct Factor.
- (2) Margin Level = Measurement Value - Limit Value.

Orthogonal Axis	X
Test Mode	UNII-2A_TX A Mode 5320 MHz

### Horizontal

130 dBuV/m

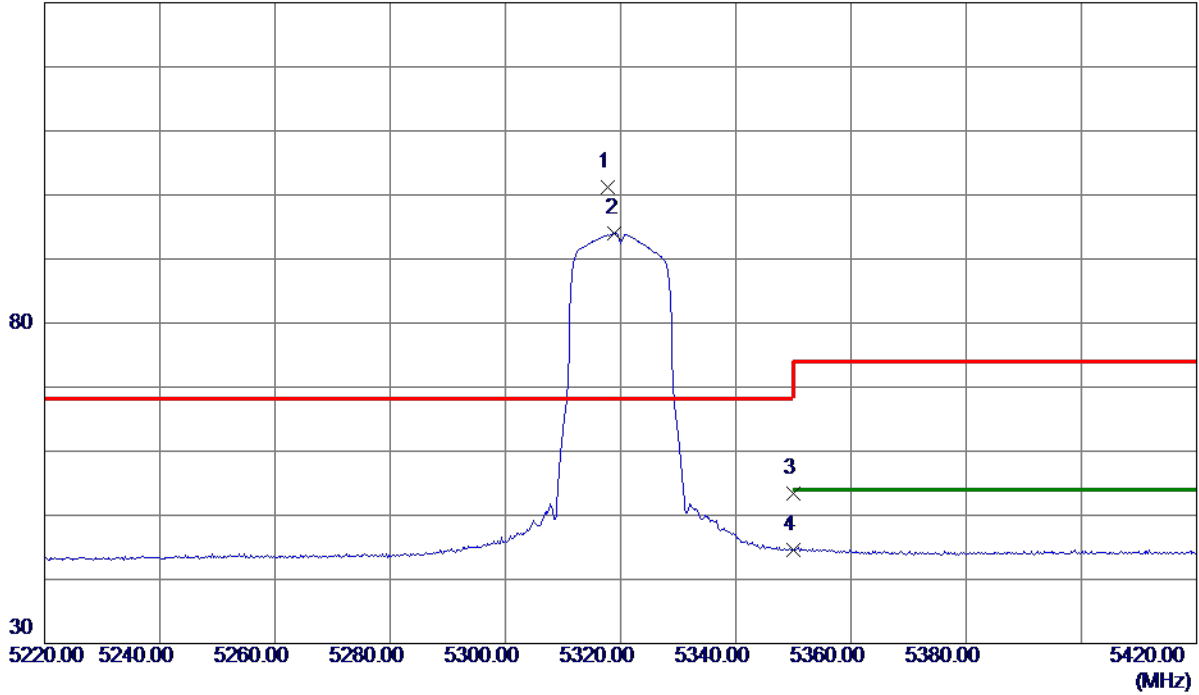

No.	Freq. MHz	Reading Level dBuV/m	Correct Factor dB	Measure ment dBuV/m	Limit dBuV/m	Margin dB	Detector	Comment
1 *	5317.8000	86.35	14.93	101.28	68.30	32.98	Peak	No Limit
2	5319.0000	79.12	14.94	94.06	999.00	-904.94	AVG	No Limit
3	5350.0000	38.30	15.02	53.32	74.00	-20.68	Peak	
4	5350.0000	29.58	15.02	44.60	54.00	-9.40	AVG	

**REMARKS:**

- (1) Measurement Value = Reading Level + Correct Factor.
- (2) Margin Level = Measurement Value - Limit Value.

Orthogonal Axis	X
Test Mode	UNII-2A_TX A Mode 5320 MHz

### Horizontal

80 dBuV/m

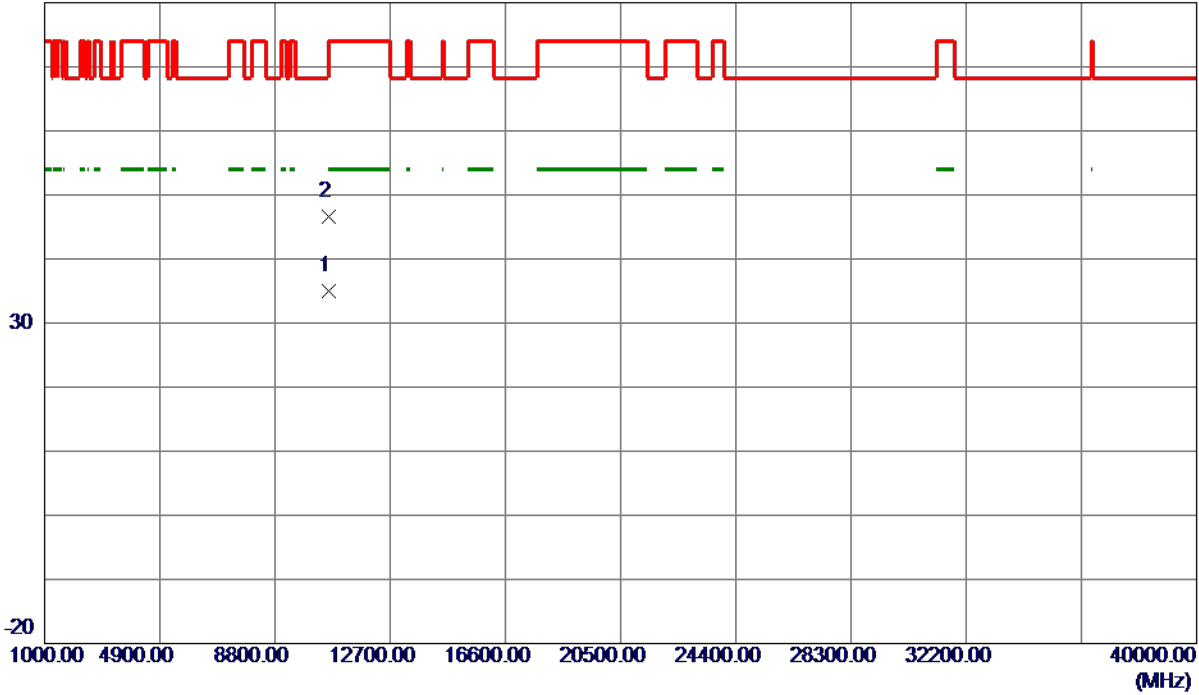

No.	Freq. MHz	Reading Level dBuV/m	Correct Factor dB	Measure ment dBuV/m	Limit dBuV/m	Margin dB	Detector	Comment
1 *	10640.1070	23.42	11.56	34.98	54.00	-19.02	AVG	
2	10640.4390	34.97	11.56	46.53	74.00	-27.47	Peak	

**REMARKS:**

- (1) Measurement Value = Reading Level + Correct Factor.
- (2) Margin Level = Measurement Value - Limit Value.



Orthogonal Axis	X
Test Mode	UNII-2A_TX N (HT20) Mode 5260 MHz

**Vertical**

130 dBuV/m

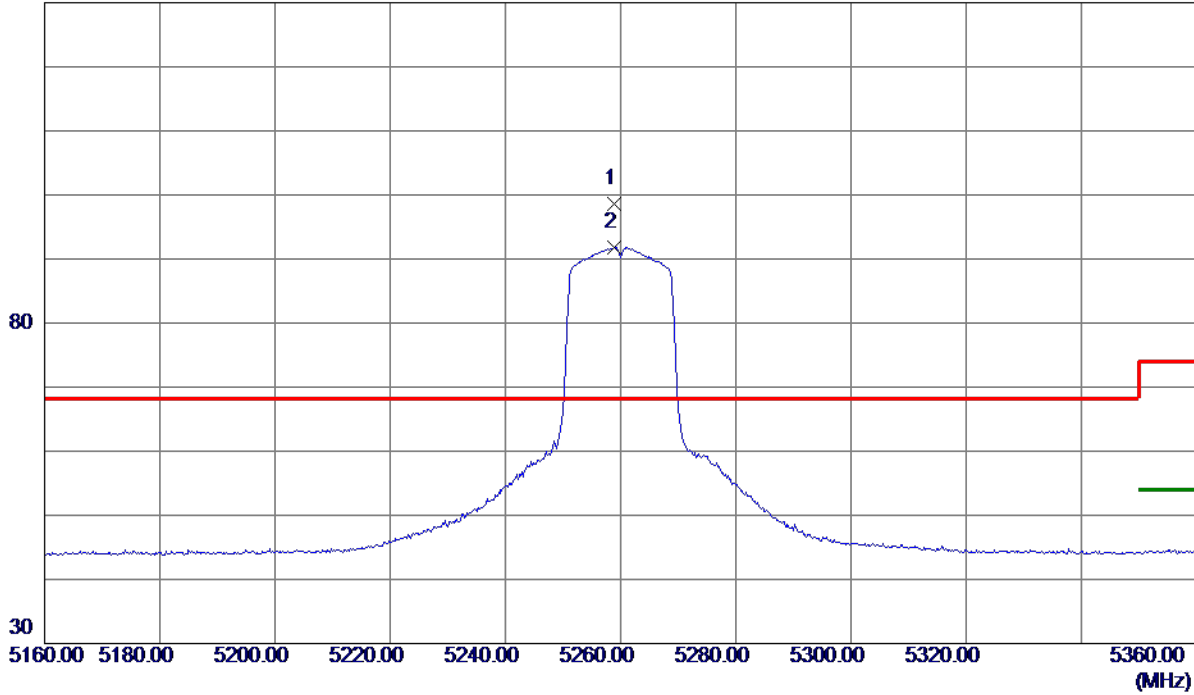

No.	Freq. MHz	Reading Level dBuV/m	Correct Factor dB	Measure ment dBuV/m	Limit dBuV/m	Margin dB	Detector	Comment
1 *	5258.8000	83.86	14.78	98.64	68.30	30.34	Peak	No Limit
2	5258.8000	77.09	14.78	91.87	999.00	-907.13	AVG	No Limit

**REMARKS:**

- (1) Measurement Value = Reading Level + Correct Factor.
- (2) Margin Level = Measurement Value - Limit Value.

Orthogonal Axis	X
Test Mode	UNII-2A_TX N (HT20) Mode 5260 MHz

**Vertical**

80 dBuV/m

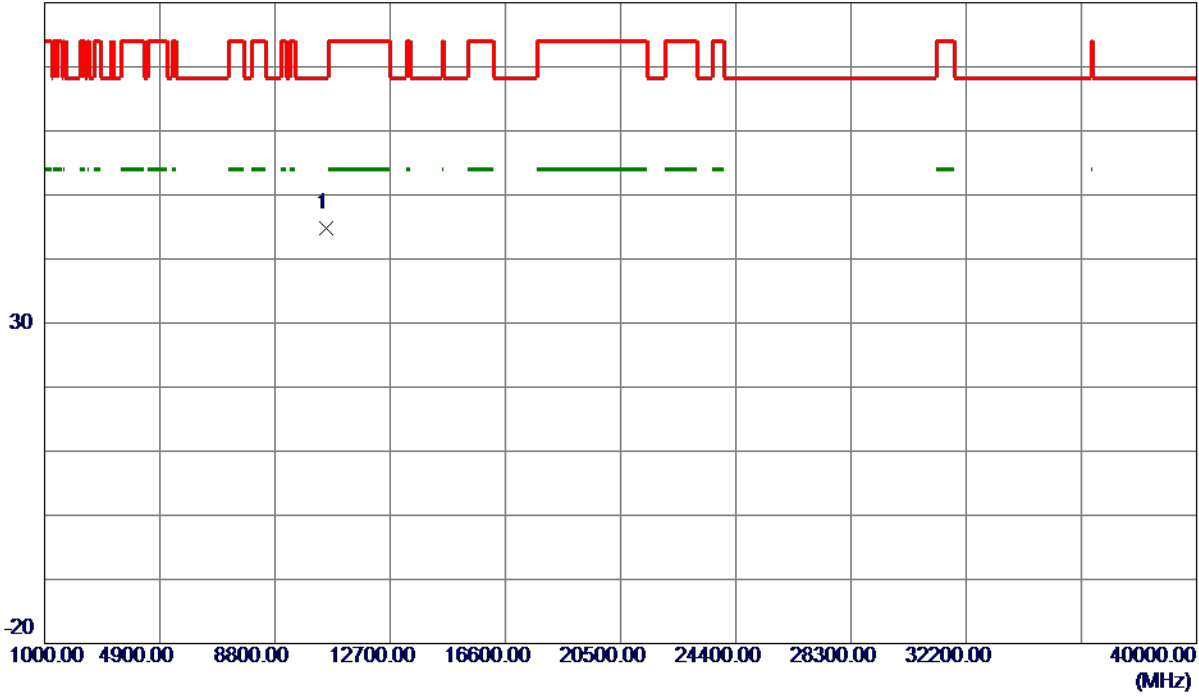

No.	Freq. MHz	Reading Level dBuV/m	Correct Factor dB	Measure ment dBuV/m	Limit dBuV/m	Margin dB	Detector	Comment
1 *	10519.0150	33.19	11.54	44.73	68.30	-23.57	Peak	

**REMARKS:**

- (1) Measurement Value = Reading Level + Correct Factor.
- (2) Margin Level = Measurement Value - Limit Value.

Orthogonal Axis	X
Test Mode	UNII-2A_TX N (HT20) Mode 5260 MHz

### Horizontal

130 dBuV/m

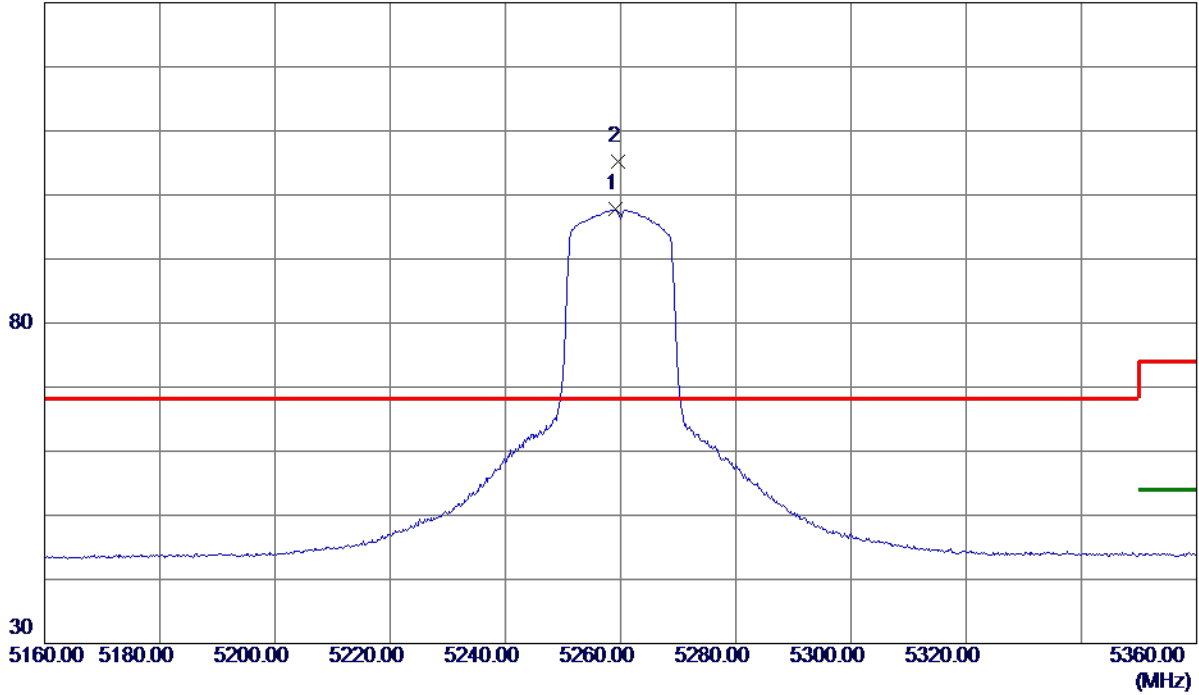

No.	Freq. MHz	Reading Level dBuV/m	Correct Factor dB	Measure ment dBuV/m	Limit dBuV/m	Margin dB	Detector	Comment
1	5259.2000	82.97	14.79	97.76	999.00	-901.24	AVG	No Limit
2 *	5259.6000	90.47	14.79	105.26	68.30	36.96	Peak	No Limit

**REMARKS:**

- (1) Measurement Value = Reading Level + Correct Factor.
- (2) Margin Level = Measurement Value - Limit Value.

Orthogonal Axis	X
Test Mode	UNII-2A_TX N (HT20) Mode 5260 MHz

### Horizontal

80 dBuV/m

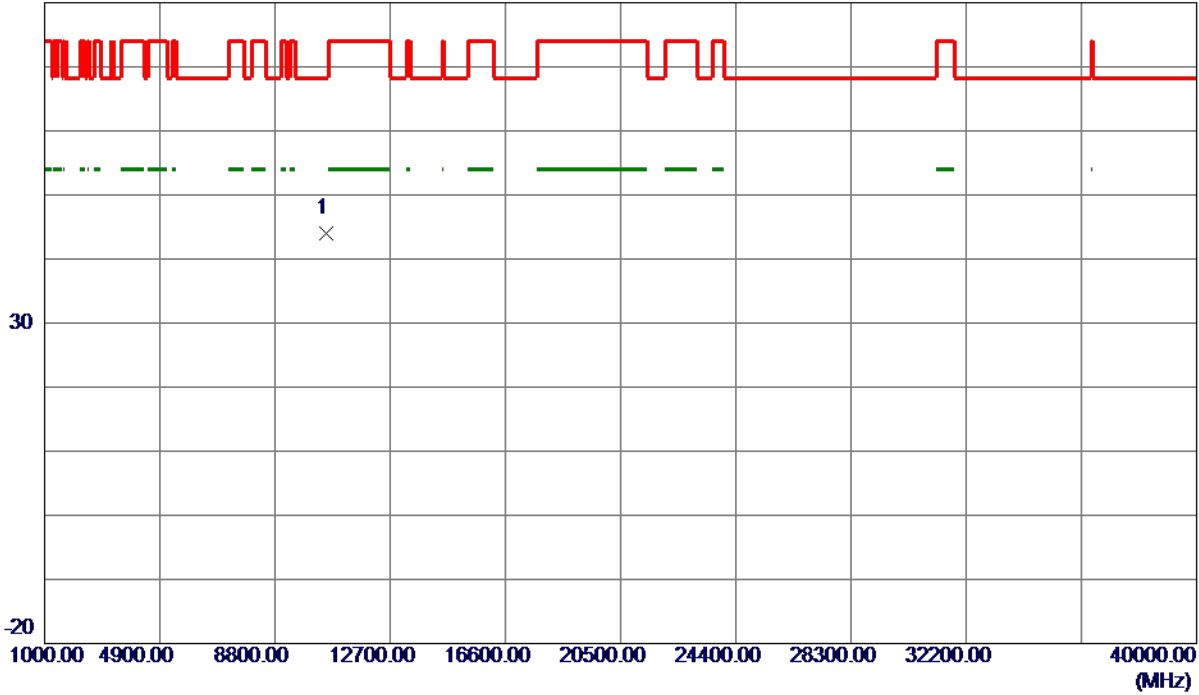

No.	Freq. MHz	Reading Level dBuV/m	Correct Factor dB	Measure ment dBuV/m	Limit dBuV/m	Margin dB	Detector	Comment
1 *	10522.4900	32.42	11.54	43.96	68.30	-24.34	Peak	

**REMARKS:**

- (1) Measurement Value = Reading Level + Correct Factor.
- (2) Margin Level = Measurement Value - Limit Value.

Orthogonal Axis	X
Test Mode	UNII-2A_TX N (HT20) Mode 5300 MHz

**Vertical**

130 dBuV/m

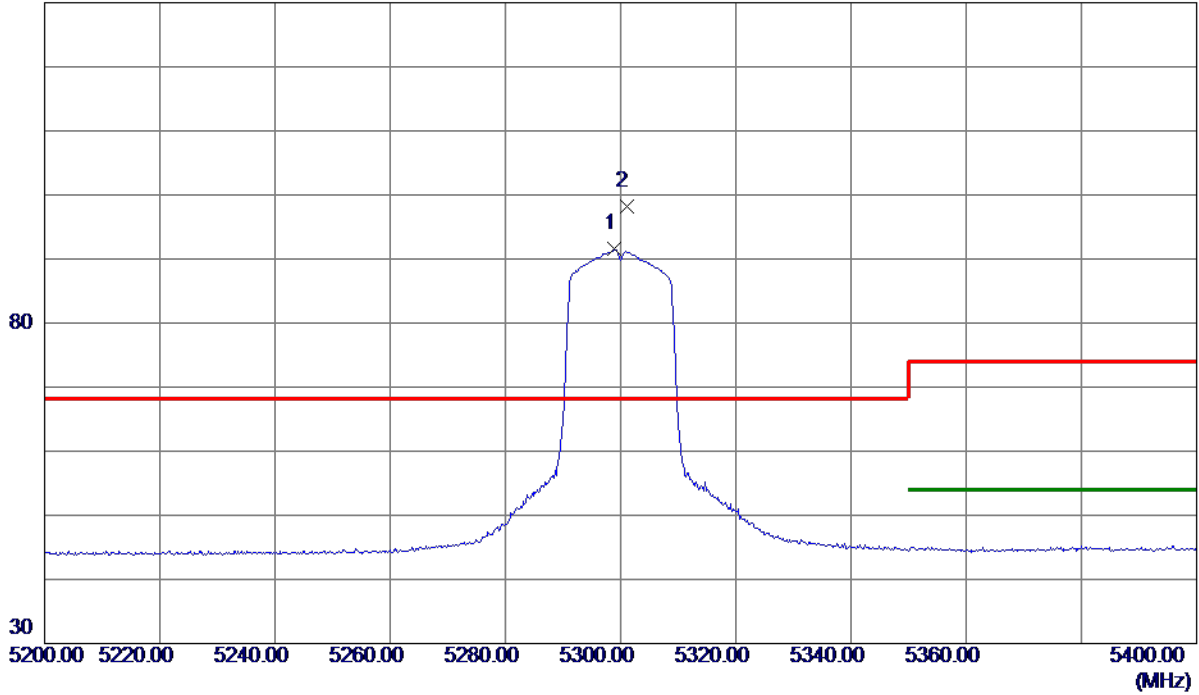

No.	Freq. MHz	Reading Level dBuV/m	Correct Factor dB	Measure ment dBuV/m	Limit dBuV/m	Margin dB	Detector	Comment
1	5298.8000	76.63	14.89	91.52	999.00	-907.48	AVG	No Limit
2 *	5301.0000	83.33	14.89	98.22	68.30	29.92	Peak	No Limit

**REMARKS:**

- (1) Measurement Value = Reading Level + Correct Factor.
- (2) Margin Level = Measurement Value - Limit Value.

Orthogonal Axis	X
Test Mode	UNII-2A_TX N (HT20) Mode 5300 MHz

**Vertical**

80 dBuV/m

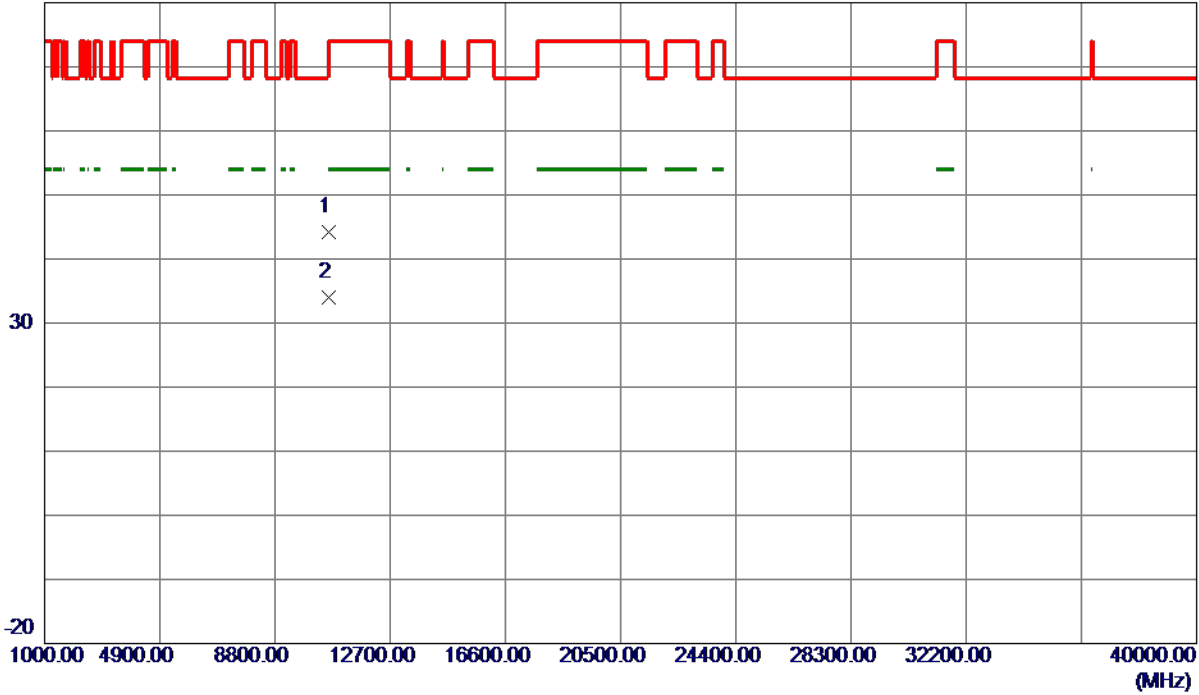

No.	Freq. MHz	Reading Level dBuV/m	Correct Factor dB	Measure ment dBuV/m	Limit dBuV/m	Margin dB	Detector	Comment
1	10600.8350	32.72	11.55	44.27	74.00	-29.73	Peak	
2 *	10602.7050	22.37	11.55	33.92	54.00	-20.08	AVG	

**REMARKS:**

- (1) Measurement Value = Reading Level + Correct Factor.
- (2) Margin Level = Measurement Value - Limit Value.

Orthogonal Axis	X
Test Mode	UNII-2A_TX N (HT20) Mode 5300 MHz

### Horizontal

130 dBuV/m

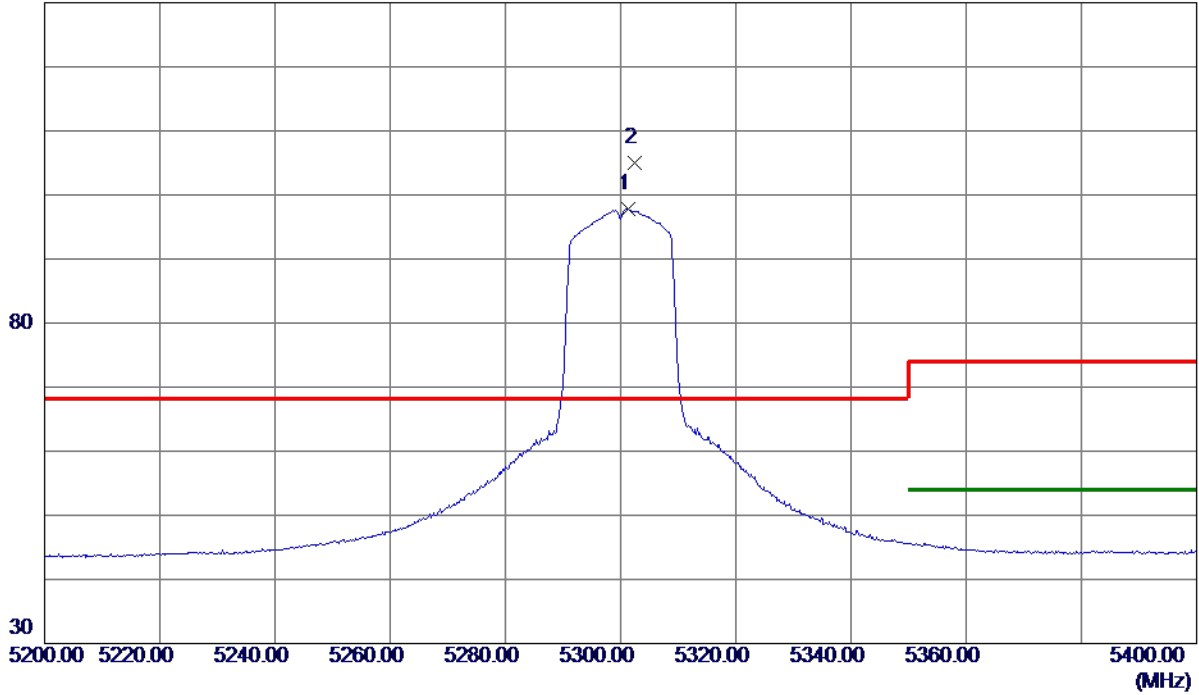

No.	Freq. MHz	Reading Level dBuV/m	Correct Factor dB	Measure ment dBuV/m	Limit dBuV/m	Margin dB	Detector	Comment
1	5301.4000	82.87	14.89	97.76	999.00	-901.24	AVG	No Limit
2 *	5302.4000	90.12	14.90	105.02	68.30	36.72	Peak	No Limit

**REMARKS:**

- (1) Measurement Value = Reading Level + Correct Factor.
- (2) Margin Level = Measurement Value - Limit Value.

Orthogonal Axis	X
Test Mode	UNII-2A_TX N (HT20) Mode 5300 MHz

### Horizontal

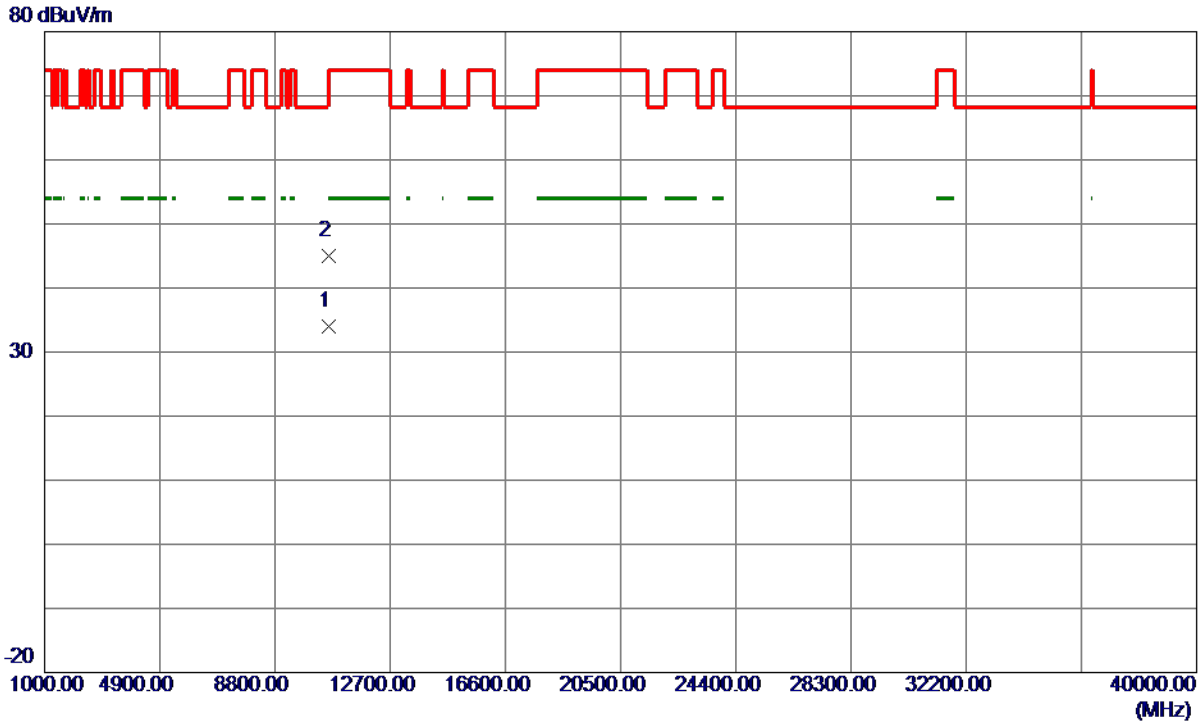

No.	Freq. MHz	Reading Level dBuV/m	Correct Factor dB	Measure ment dBuV/m	Limit dBuV/m	Margin dB	Detector	Comment
1 *	10603.3000	22.43	11.55	33.98	54.00	-20.02	AVG	
2	10603.3400	33.43	11.55	44.98	74.00	-29.02	Peak	

**REMARKS:**

- (1) Measurement Value = Reading Level + Correct Factor.
- (2) Margin Level = Measurement Value - Limit Value.



Orthogonal Axis	X
Test Mode	UNII-2A_TX N (HT20) Mode 5320 MHz

**Vertical**

130 dBuV/m

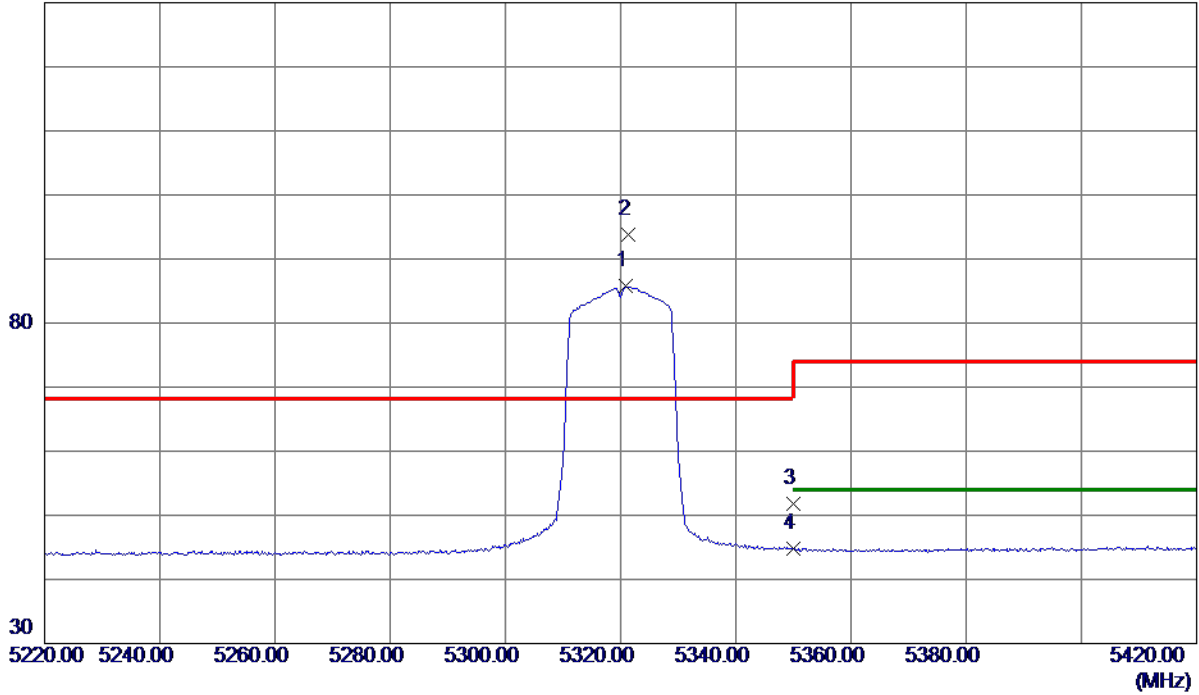

No.	Freq. MHz	Reading Level dBuV/m	Correct Factor dB	Measure ment dBuV/m	Limit dBuV/m	Margin dB	Detector	Comment
1	5320.8000	70.81	14.94	85.75	999.00	-913.25	AVG	No Limit
2 *	5321.4000	78.90	14.94	93.84	68.30	25.54	Peak	No Limit
3	5350.0000	36.69	15.02	51.71	74.00	-22.29	Peak	
4	5350.0000	29.76	15.02	44.78	54.00	-9.22	AVG	

**REMARKS:**

- (1) Measurement Value = Reading Level + Correct Factor.
- (2) Margin Level = Measurement Value - Limit Value.

Orthogonal Axis	X
Test Mode	UNII-2A_TX N (HT20) Mode 5320 MHz

**Vertical**

80 dBuV/m

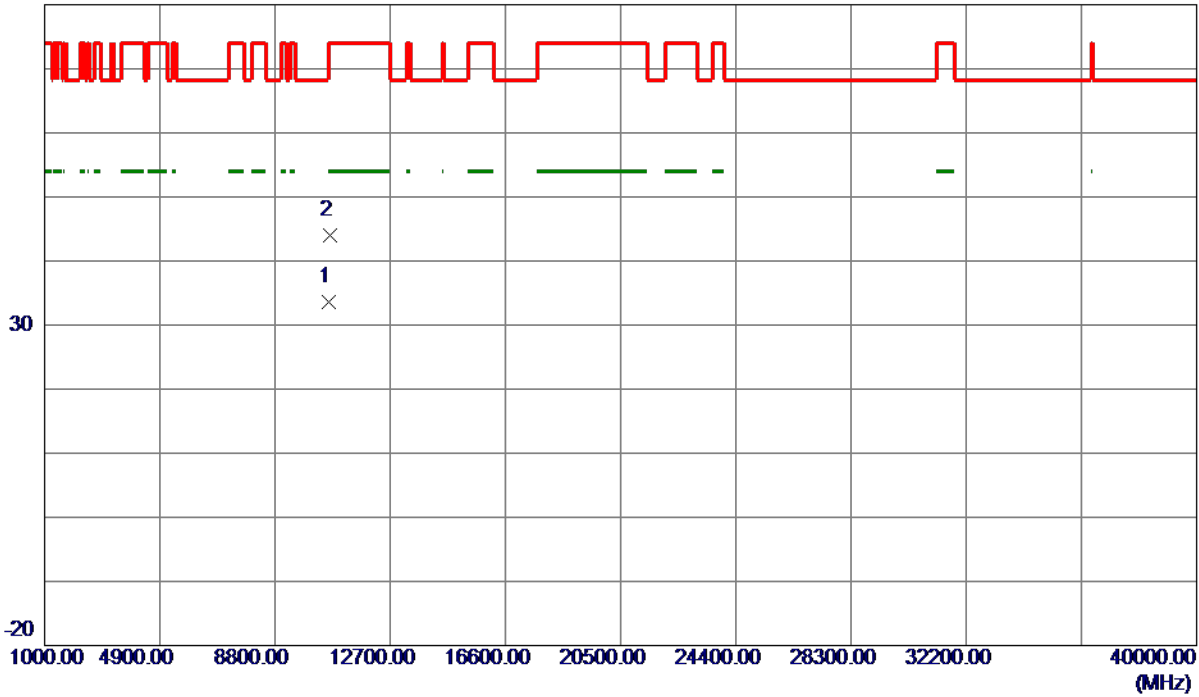

No.	Freq. MHz	Reading Level dBuV/m	Correct Factor dB	Measure ment dBuV/m	Limit dBuV/m	Margin dB	Detector	Comment
1 *	10636.2850	22.10	11.56	33.66	54.00	-20.34	AVG	
2	10642.8000	32.51	11.56	44.07	74.00	-29.93	Peak	

**REMARKS:**

- (1) Measurement Value = Reading Level + Correct Factor.
- (2) Margin Level = Measurement Value - Limit Value.

Orthogonal Axis	X
Test Mode	UNII-2A_TX N (HT20) Mode 5320 MHz

### Horizontal

130 dBuV/m

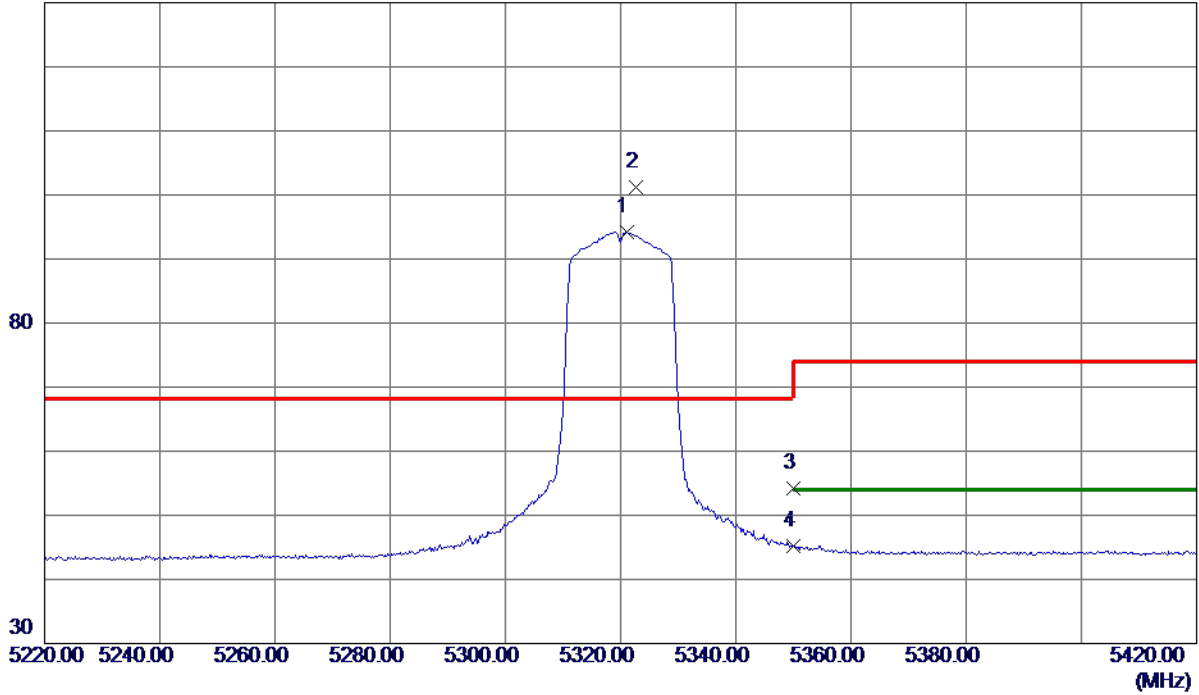

No.	Freq. MHz	Reading Level dBuV/m	Correct Factor dB	Measure ment dBuV/m	Limit dBuV/m	Margin dB	Detector	Comment
1	5321.0000	79.27	14.94	94.21	999.00	-904.79	AVG	No Limit
2 *	5322.6000	86.25	14.95	101.20	68.30	32.90	Peak	No Limit
3	5350.0000	39.25	15.02	54.27	74.00	-19.73	Peak	
4	5350.0000	30.27	15.02	45.29	54.00	-8.71	AVG	

**REMARKS:**

- (1) Measurement Value = Reading Level + Correct Factor.
- (2) Margin Level = Measurement Value - Limit Value.

Orthogonal Axis	X
Test Mode	UNII-2A_TX N (HT20) Mode 5320 MHz

### Horizontal

80 dBuV/m

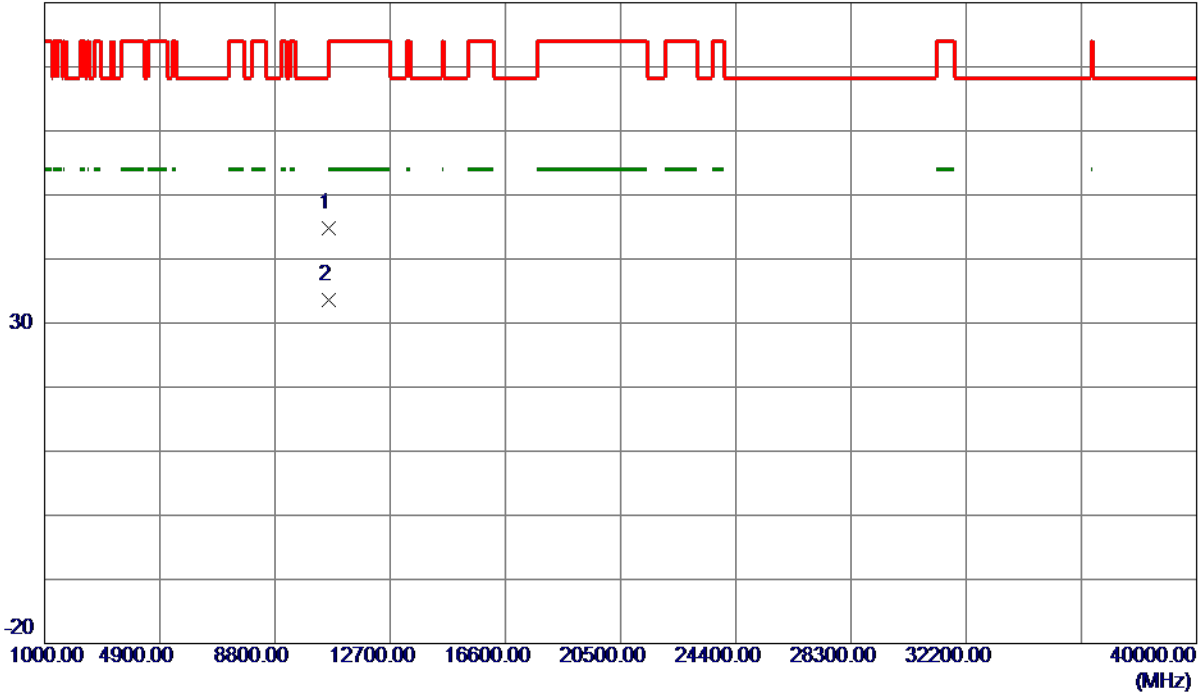

No.	Freq. MHz	Reading Level dBuV/m	Correct Factor dB	Measure ment dBuV/m	Limit dBuV/m	Margin dB	Detector	Comment
1	10635.2800	33.18	11.56	44.74	74.00	-29.26	Peak	
2 *	10636.2100	22.02	11.56	33.58	54.00	-20.42	AVG	

**REMARKS:**

- (1) Measurement Value = Reading Level + Correct Factor.
- (2) Margin Level = Measurement Value - Limit Value.

Orthogonal Axis	X
Test Mode	UNII-2A_TX N (HT40) Mode 5270 MHz

**Vertical**

130 dBuV/m

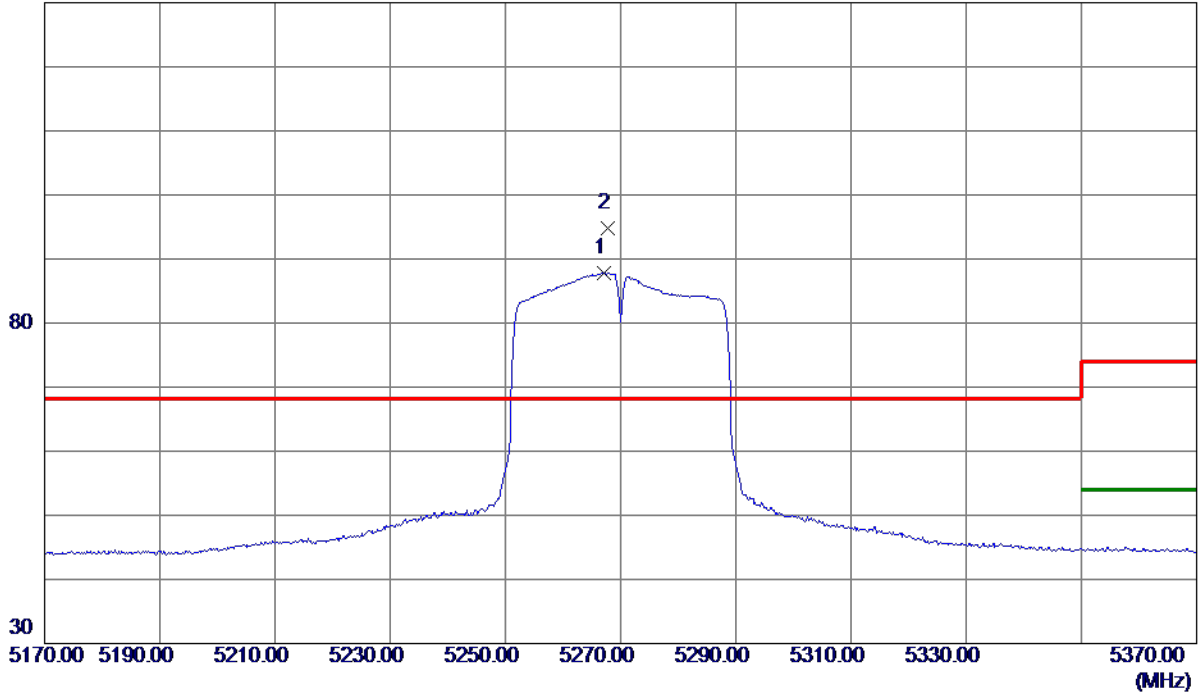

No.	Freq. MHz	Reading Level dBuV/m	Correct Factor dB	Measure ment dBuV/m	Limit dBuV/m	Margin dB	Detector	Comment
1	5267.2000	73.01	14.81	87.82	999.00	-911.18	AVG	No Limit
2 *	5267.8000	80.05	14.81	94.86	68.30	26.56	Peak	No Limit

**REMARKS:**

- (1) Measurement Value = Reading Level + Correct Factor.
- (2) Margin Level = Measurement Value - Limit Value.

Orthogonal Axis	X
Test Mode	UNII-2A_TX N (HT40) Mode 5270 MHz

**Vertical**

80 dBuV/m

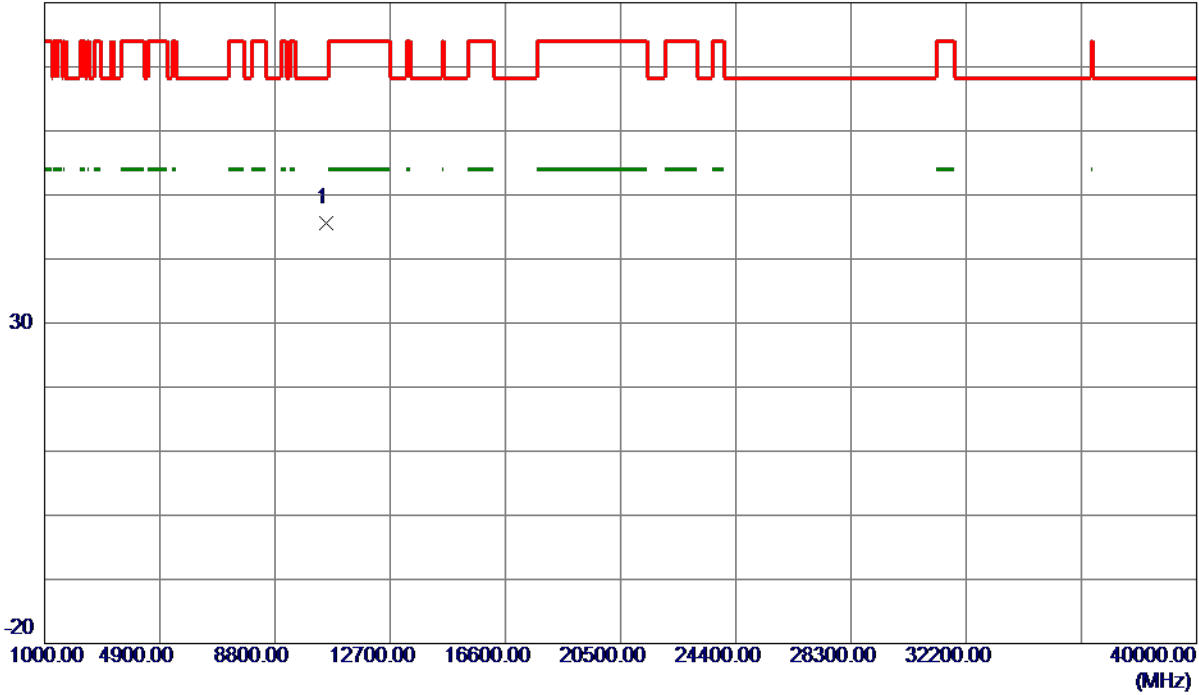

No.	Freq. MHz	Reading Level dBuV/m	Correct Factor dB	Measure ment dBuV/m	Limit dBuV/m	Margin dB	Detector	Comment
1 *	10541.9650	33.98	11.54	45.52	68.30	-22.78	Peak	

**REMARKS:**

- (1) Measurement Value = Reading Level + Correct Factor.
- (2) Margin Level = Measurement Value - Limit Value.

Orthogonal Axis	X
Test Mode	UNII-2A_TX N (HT40) Mode 5270 MHz

### Horizontal

130 dBuV/m

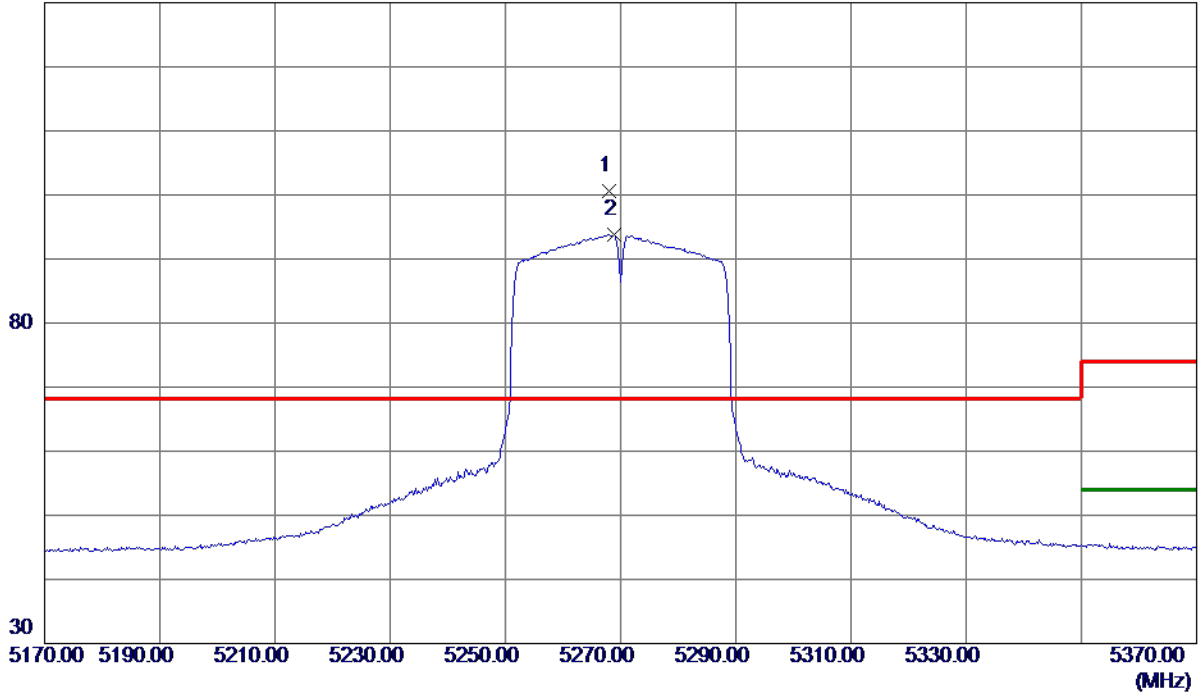

No.	Freq. MHz	Reading Level dBuV/m	Correct Factor dB	Measure ment dBuV/m	Limit dBuV/m	Margin dB	Detector	Comment
1 *	5268.0000	85.81	14.81	100.62	68.30	32.32	Peak	No Limit
2	5268.8000	78.98	14.81	93.79	999.00	-905.21	AVG	No Limit

**REMARKS:**

- (1) Measurement Value = Reading Level + Correct Factor.
- (2) Margin Level = Measurement Value - Limit Value.

Orthogonal Axis	X
Test Mode	UNII-2A_TX N (HT40) Mode 5270 MHz

### Horizontal

80 dBuV/m

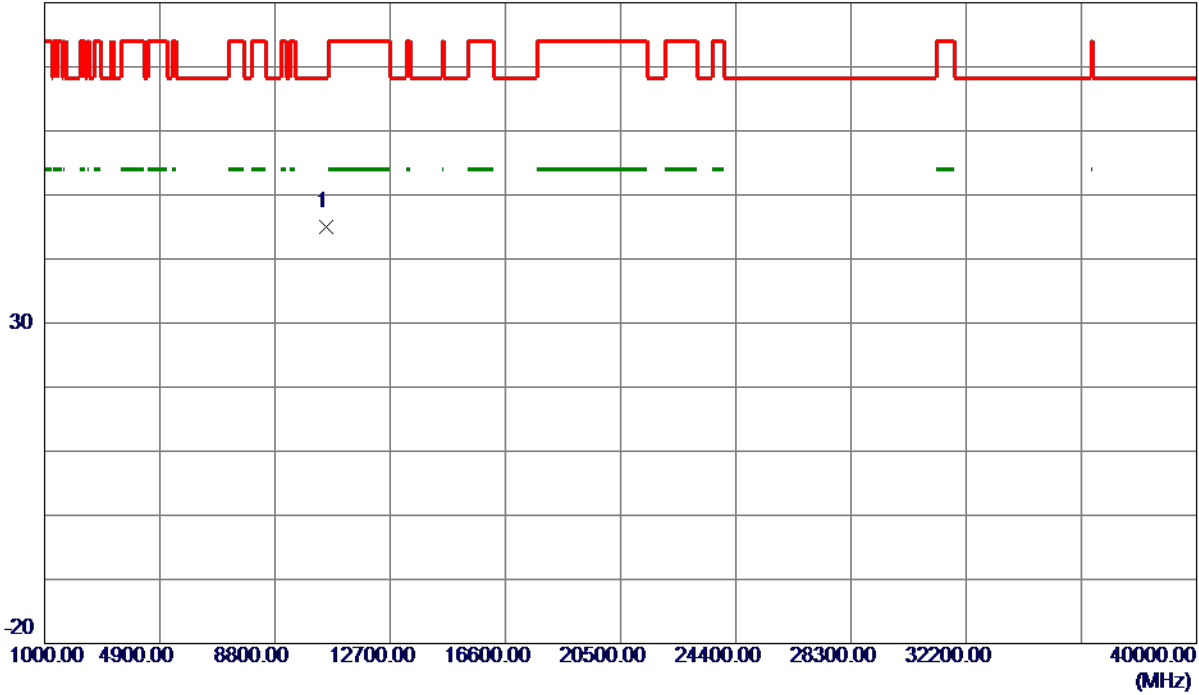

No.	Freq. MHz	Reading Level dBuV/m	Correct Factor dB	Measure ment dBuV/m	Limit dBuV/m	Margin dB	Detector	Comment
1 *	10541.5350	33.42	11.54	44.96	68.30	-23.34	Peak	

**REMARKS:**

- (1) Measurement Value = Reading Level + Correct Factor.
- (2) Margin Level = Measurement Value - Limit Value.



Orthogonal Axis	X
Test Mode	UNII-2A_TX N (HT40) Mode 5310 MHz

**Vertical**

130 dBuV/m

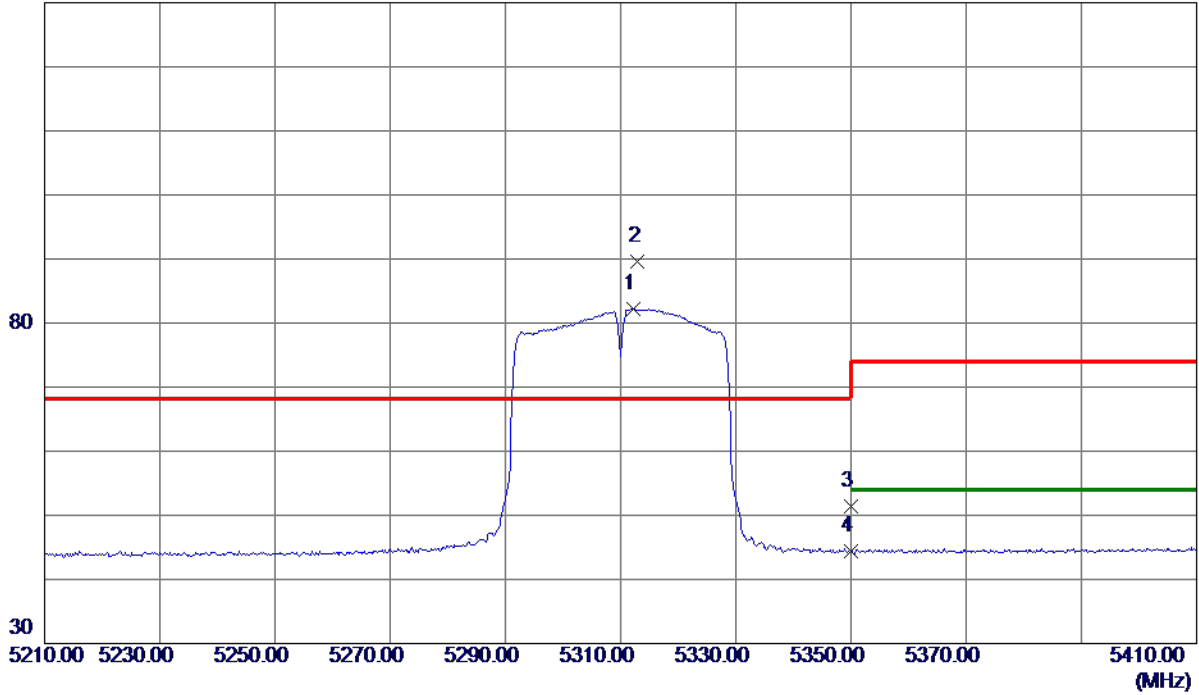

No.	Freq. MHz	Reading Level dBuV/m	Correct Factor dB	Measure ment dBuV/m	Limit dBuV/m	Margin dB	Detector	Comment
1	5312.2000	67.27	14.92	82.19	999.00	-916.81	AVG	No Limit
2 *	5313.0000	74.63	14.92	89.55	68.30	21.25	Peak	No Limit
3	5350.0000	36.45	15.02	51.47	74.00	-22.53	Peak	
4	5350.0000	29.32	15.02	44.34	54.00	-9.66	AVG	

**REMARKS:**

- (1) Measurement Value = Reading Level + Correct Factor.
- (2) Margin Level = Measurement Value - Limit Value.

Orthogonal Axis	X
Test Mode	UNII-2A_TX N (HT40) Mode 5310 MHz

**Vertical**

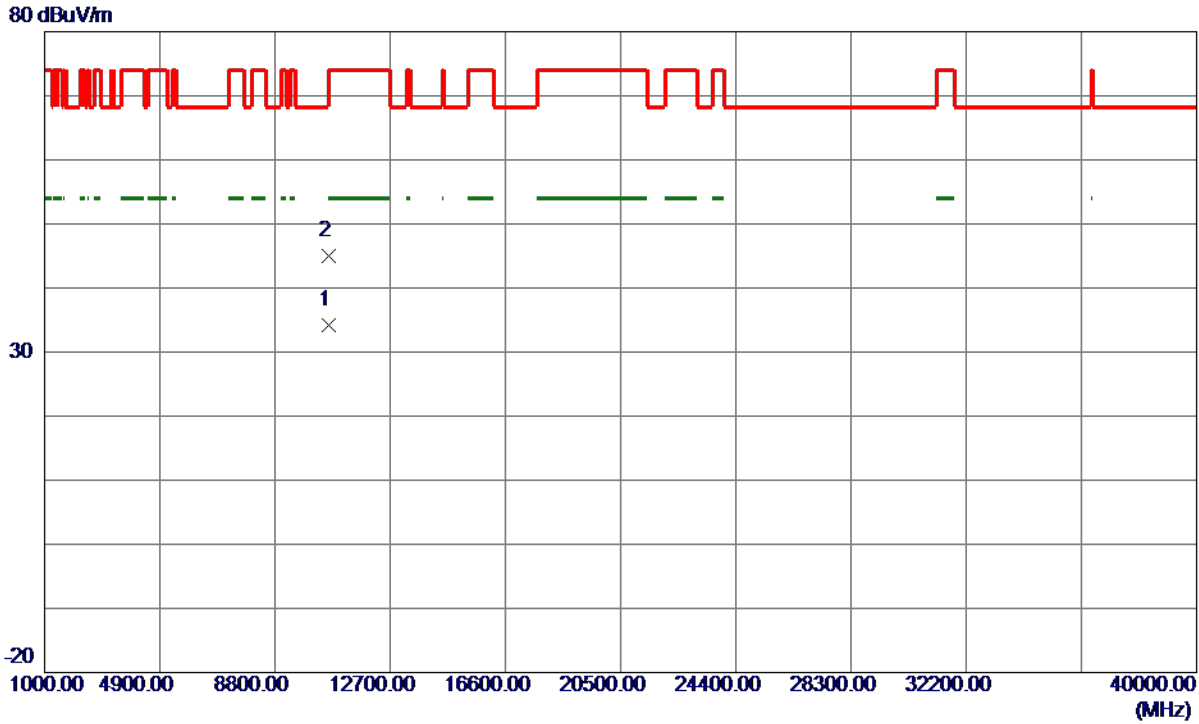

No.	Freq. MHz	Reading Level dBuV/m	Correct Factor dB	Measure ment dBuV/m	Limit dBuV/m	Margin dB	Detector	Comment
1 *	10620.3250	22.64	11.56	34.20	54.00	-19.80	AVG	
2	10622.7900	33.48	11.56	45.04	74.00	-28.96	Peak	

**REMARKS:**

- (1) Measurement Value = Reading Level + Correct Factor.
- (2) Margin Level = Measurement Value - Limit Value.

Orthogonal Axis	X
Test Mode	UNII-2A_TX N (HT40) Mode 5310 MHz

### Horizontal

130 dBuV/m

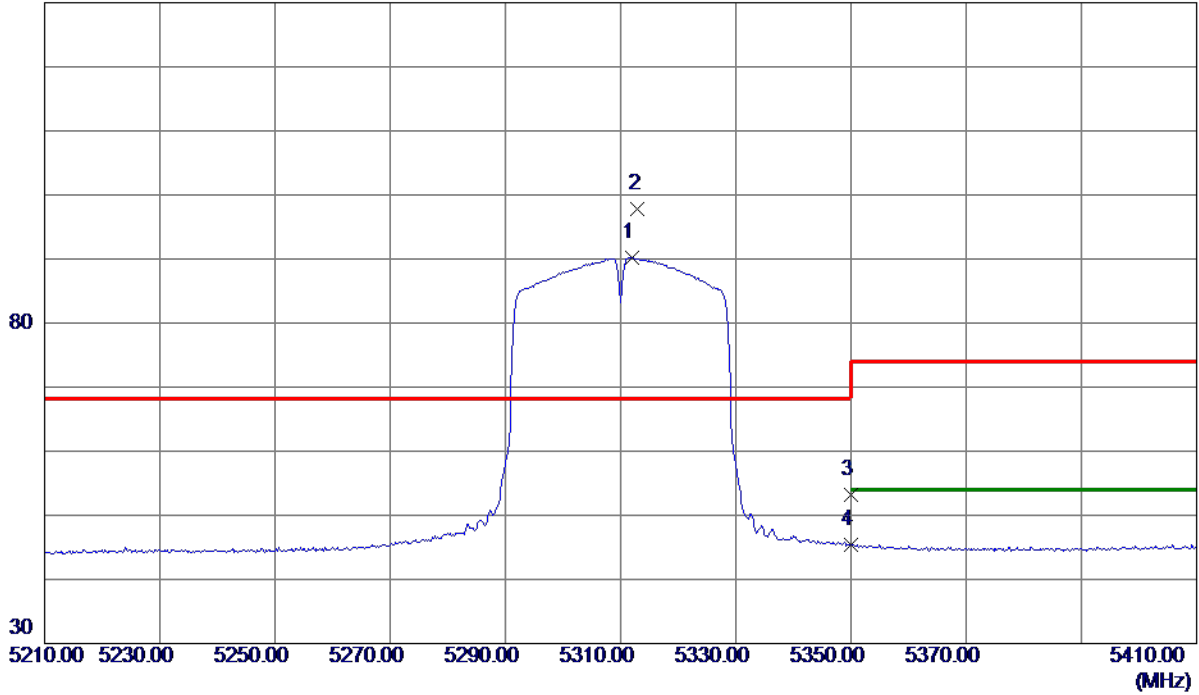

No.	Freq. MHz	Reading Level dBuV/m	Correct Factor dB	Measure ment dBuV/m	Limit dBuV/m	Margin dB	Detector	Comment
1	5312.0000	75.33	14.92	90.25	999.00	-908.75	AVG	No Limit
2 *	5313.0000	82.79	14.92	97.71	68.30	29.41	Peak	No Limit
3	5350.0000	38.15	15.02	53.17	74.00	-20.83	Peak	
4	5350.0000	30.41	15.02	45.43	54.00	-8.57	AVG	

**REMARKS:**

- (1) Measurement Value = Reading Level + Correct Factor.
- (2) Margin Level = Measurement Value - Limit Value.

Orthogonal Axis	X
Test Mode	UNII-2A_TX N (HT40) Mode 5310 MHz

### Horizontal

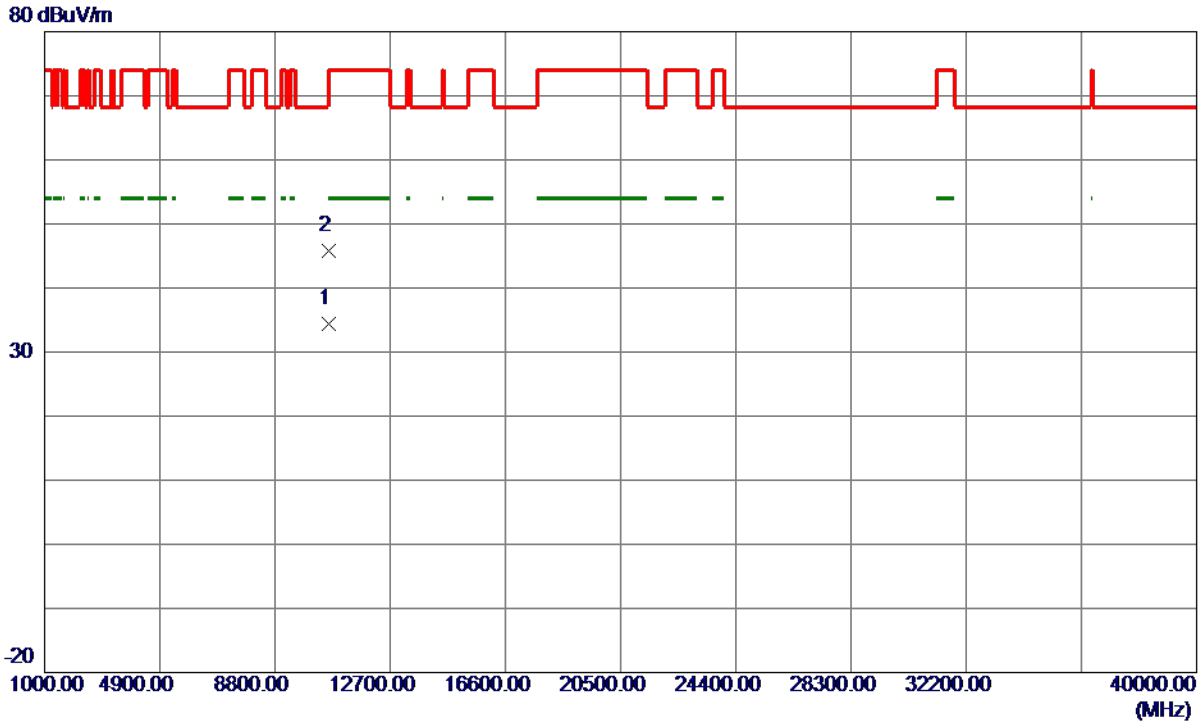

No.	Freq. MHz	Reading Level dBuV/m	Correct Factor dB	Measure ment dBuV/m	Limit dBuV/m	Margin dB	Detector	Comment
1 *	10618.7950	22.84	11.56	34.40	54.00	-19.60	AVG	
2	10619.1800	34.25	11.56	45.81	74.00	-28.19	Peak	

**REMARKS:**

- (1) Measurement Value = Reading Level + Correct Factor.
- (2) Margin Level = Measurement Value - Limit Value.

Orthogonal Axis	X
Test Mode	UNII-2C_TX A Mode 5500 MHz

### Vertical

130 dBuV/m

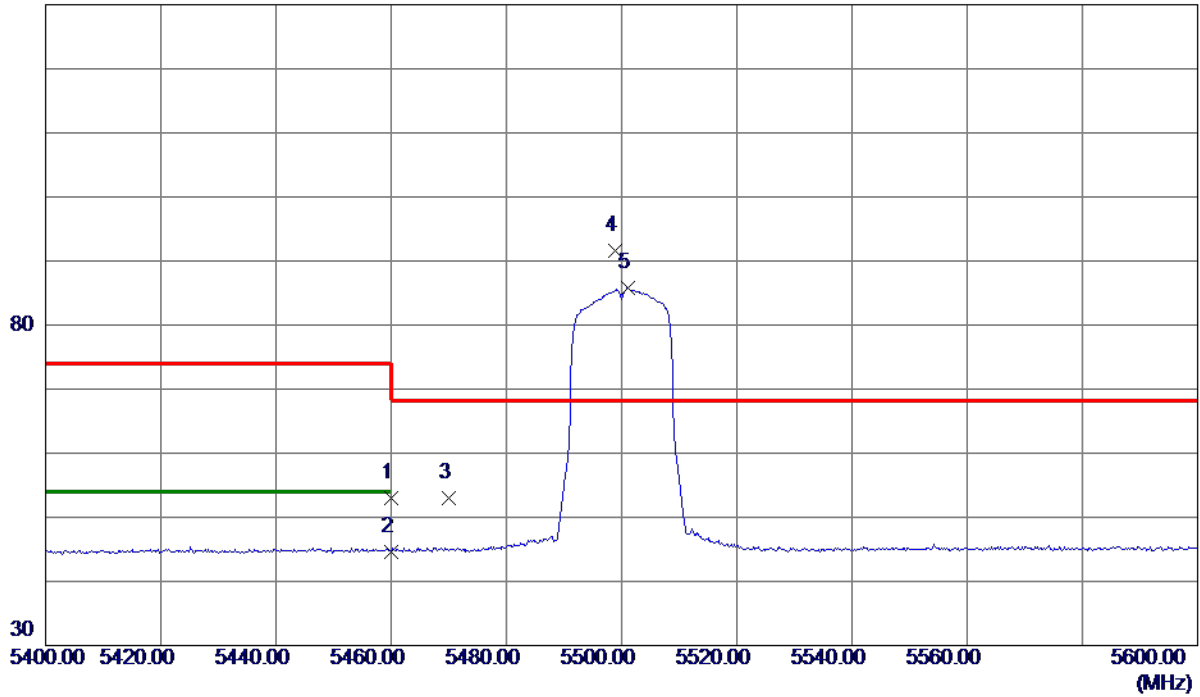

No.	Freq. MHz	Reading Level dBuV/m	Correct Factor dB	Measure ment dBuV/m	Limit dBuV/m	Margin dB	Detector	Comment
1	5460.0000	37.77	15.29	53.06	74.00	-20.94	Peak	
2	5460.0000	29.30	15.29	44.59	54.00	-9.41	AVG	
3	5470.0000	37.77	15.32	53.09	68.30	-15.21	Peak	
4 *	5498.8000	76.17	15.39	91.56	68.30	23.26	Peak	No Limit
5	5501.2000	70.43	15.40	85.83	999.00	-913.17	AVG	No Limit

**REMARKS:**

- (1) Measurement Value = Reading Level + Correct Factor.
- (2) Margin Level = Measurement Value - Limit Value.

Orthogonal Axis	X
Test Mode	UNII-2C_TX A Mode 5500 MHz

**Vertical**

80 dBuV/m

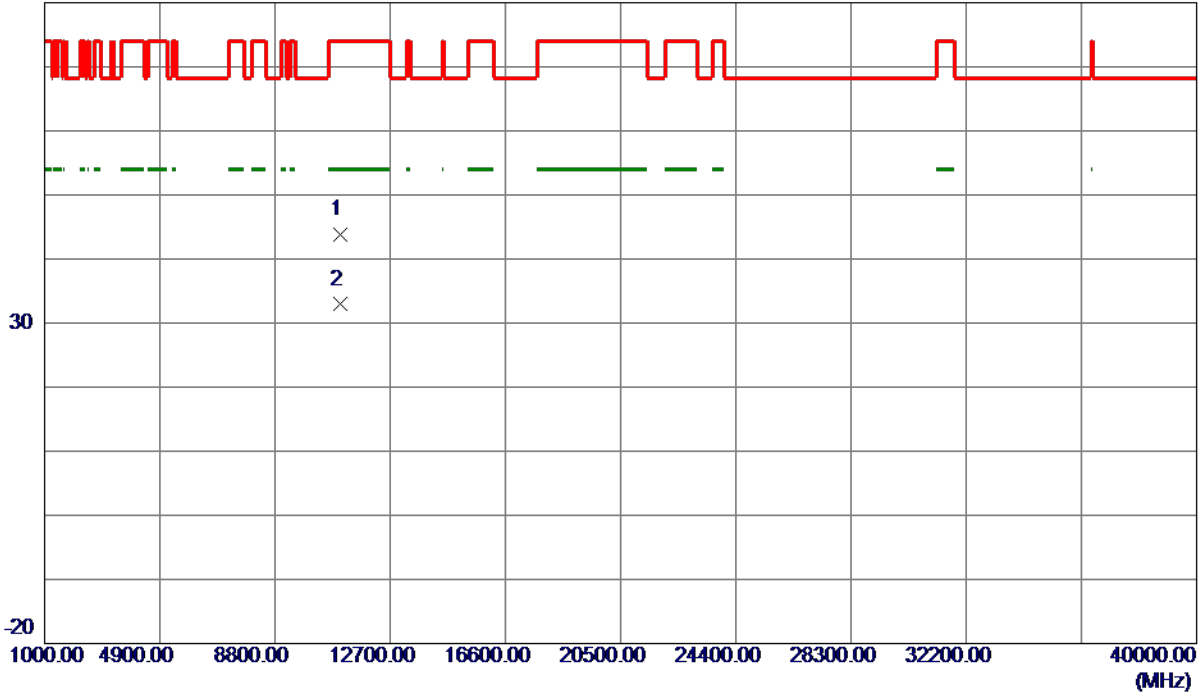

No.	Freq. MHz	Reading Level dBuV/m	Correct Factor dB	Measure ment dBuV/m	Limit dBuV/m	Margin dB	Detector	Comment
1	10998.9300	32.13	11.62	43.75	74.00	-30.25	Peak	
2 *	10999.9100	21.28	11.62	32.90	54.00	-21.10	AVG	

**REMARKS:**

- (1) Measurement Value = Reading Level + Correct Factor.
- (2) Margin Level = Measurement Value - Limit Value.

Orthogonal Axis	X
Test Mode	UNII-2C_TX A Mode 5500 MHz

### Horizontal

130 dBuV/m

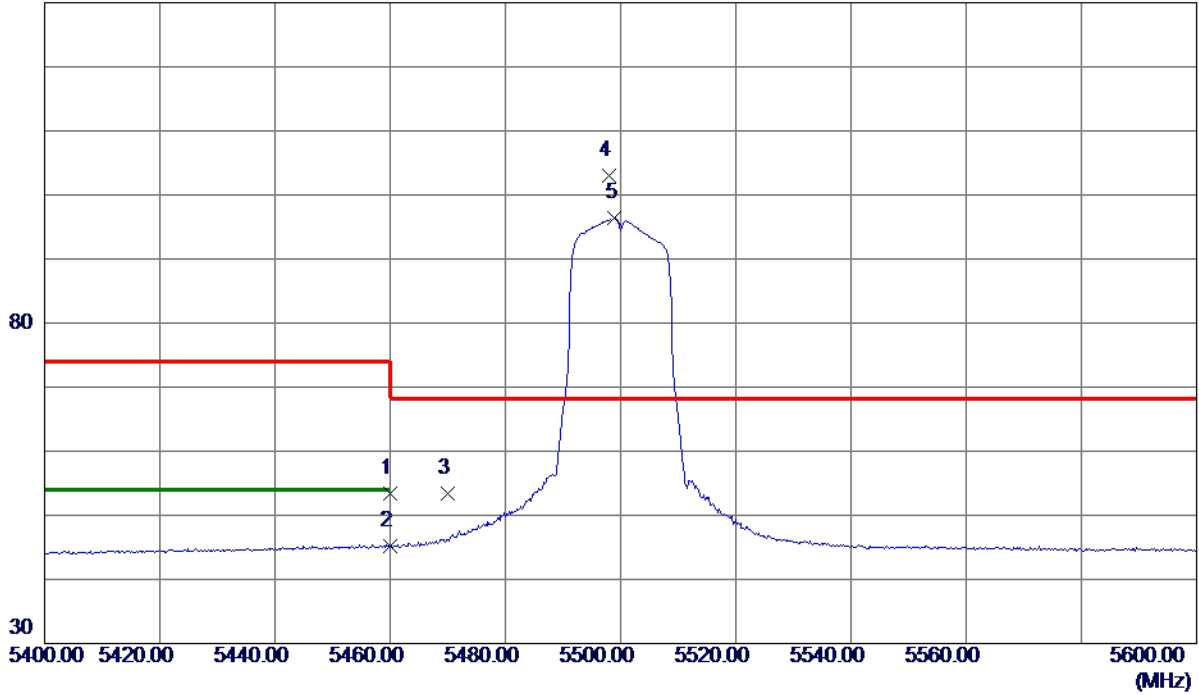

No.	Freq. MHz	Reading Level dBuV/m	Correct Factor dB	Measure ment dBuV/m	Limit dBuV/m	Margin dB	Detector	Comment
1	5460.0000	38.18	15.29	53.47	74.00	-20.53	Peak	
2	5460.0000	29.99	15.29	45.28	54.00	-8.72	AVG	
3	5470.0000	38.06	15.32	53.38	68.30	-14.92	Peak	
4 *	5498.0000	87.51	15.39	102.90	68.30	34.60	Peak	No Limit
5	5499.0000	81.00	15.39	96.39	999.00	-902.61	AVG	No Limit

**REMARKS:**

- (1) Measurement Value = Reading Level + Correct Factor.
- (2) Margin Level = Measurement Value - Limit Value.

Orthogonal Axis	X
Test Mode	UNII-2C_TX A Mode 5500 MHz

### Horizontal

80 dBuV/m

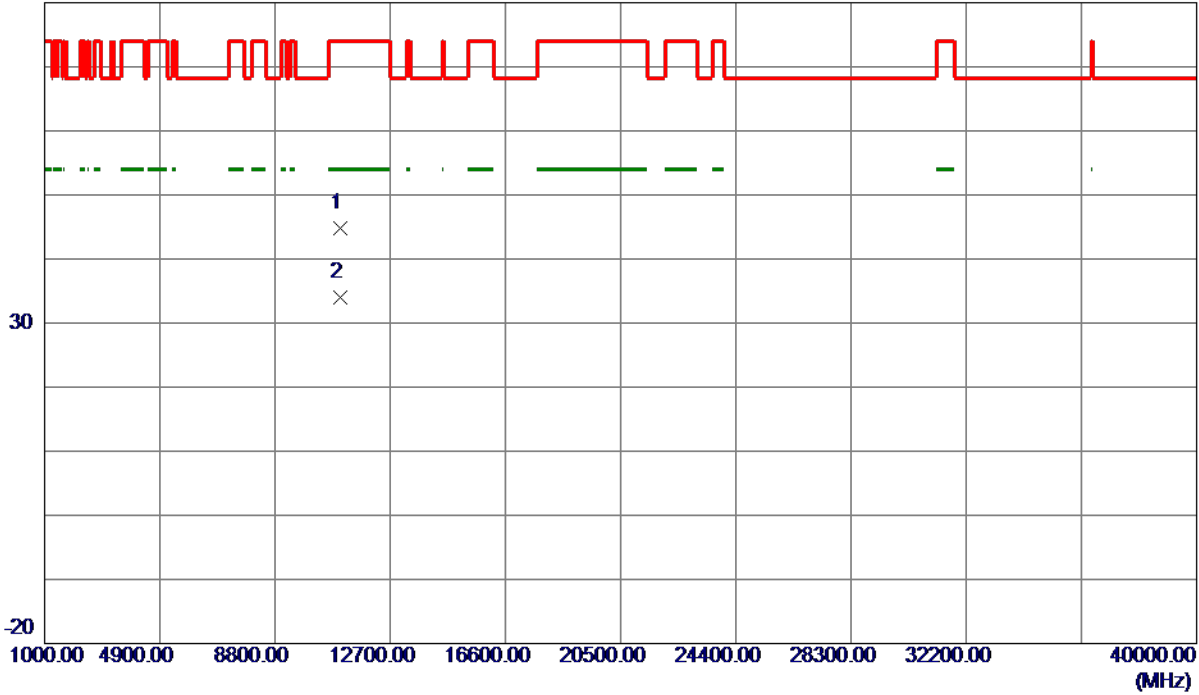

No.	Freq. MHz	Reading Level dBuV/m	Correct Factor dB	Measure ment dBuV/m	Limit dBuV/m	Margin dB	Detector	Comment
1	10997.2600	33.19	11.62	44.81	74.00	-29.19	Peak	
2 *	10999.7200	22.33	11.62	33.95	54.00	-20.05	AVG	

**REMARKS:**

- (1) Measurement Value = Reading Level + Correct Factor.
- (2) Margin Level = Measurement Value - Limit Value.



Orthogonal Axis	X
Test Mode	UNII-2C_TX A Mode 5580 MHz

**Vertical**

130 dBuV/m

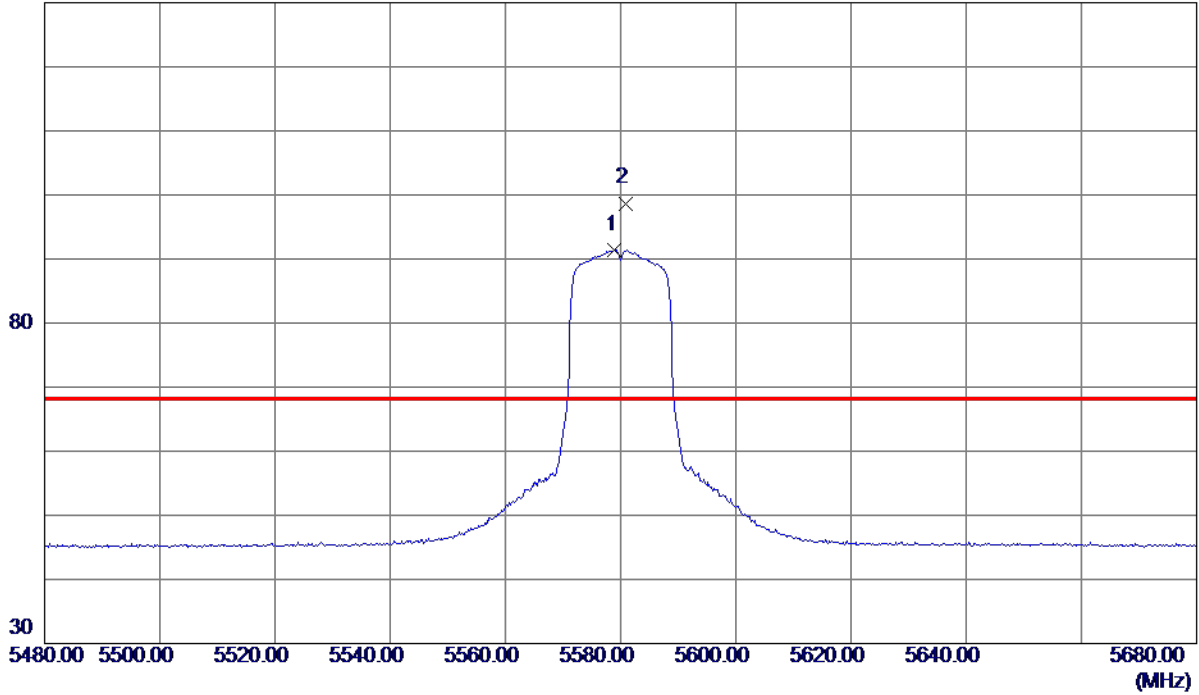

No.	Freq. MHz	Reading Level dBuV/m	Correct Factor dB	Measure ment dBuV/m	Limit dBuV/m	Margin dB	Detector	Comment
1	5579.0000	75.82	15.57	91.39	999.00	-907.61	AVG	No Limit
2 *	5580.8000	83.13	15.57	98.70	68.30	30.40	Peak	No Limit

**REMARKS:**

- (1) Measurement Value = Reading Level + Correct Factor.
- (2) Margin Level = Measurement Value - Limit Value.

Orthogonal Axis	X
Test Mode	UNII-2C_TX A Mode 5580 MHz

**Vertical**

80 dBuV/m

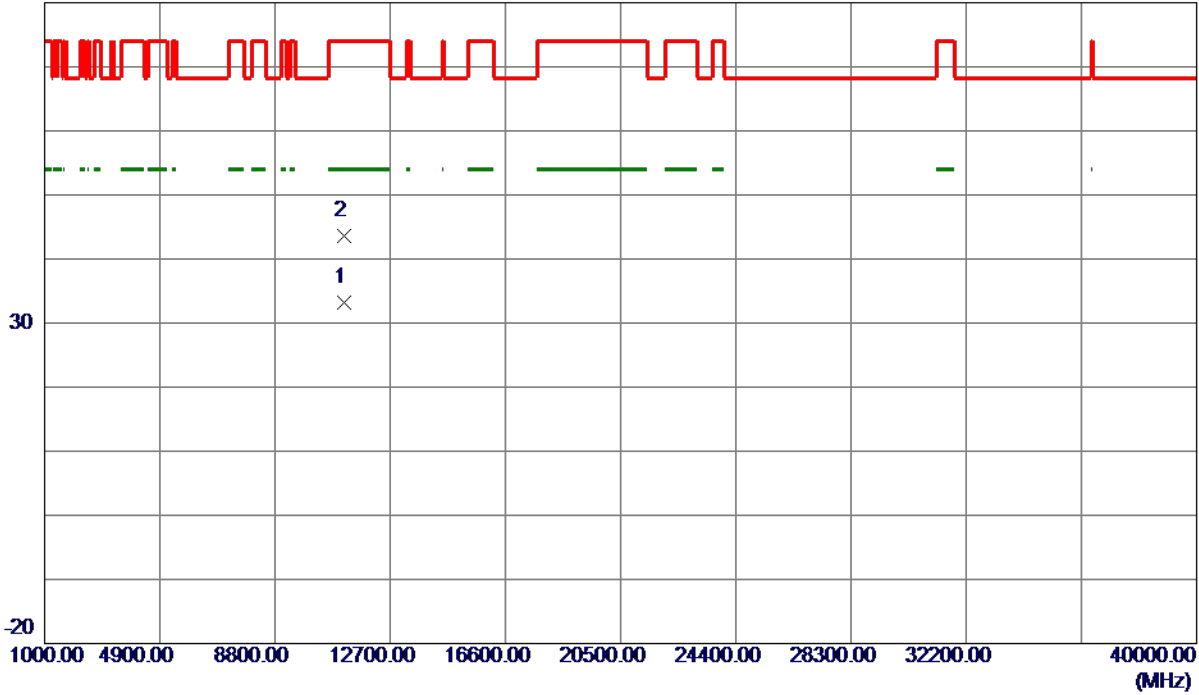

No.	Freq. MHz	Reading Level dBuV/m	Correct Factor dB	Measure ment dBuV/m	Limit dBuV/m	Margin dB	Detector	Comment
1 *	11143.3750	21.53	11.75	33.28	54.00	-20.72	AVG	
2	11145.7000	31.86	11.75	43.61	74.00	-30.39	Peak	

**REMARKS:**

- (1) Measurement Value = Reading Level + Correct Factor.
- (2) Margin Level = Measurement Value - Limit Value.

Orthogonal Axis	X
Test Mode	UNII-2C_TX A Mode 5580 MHz

### Horizontal

130 dBuV/m

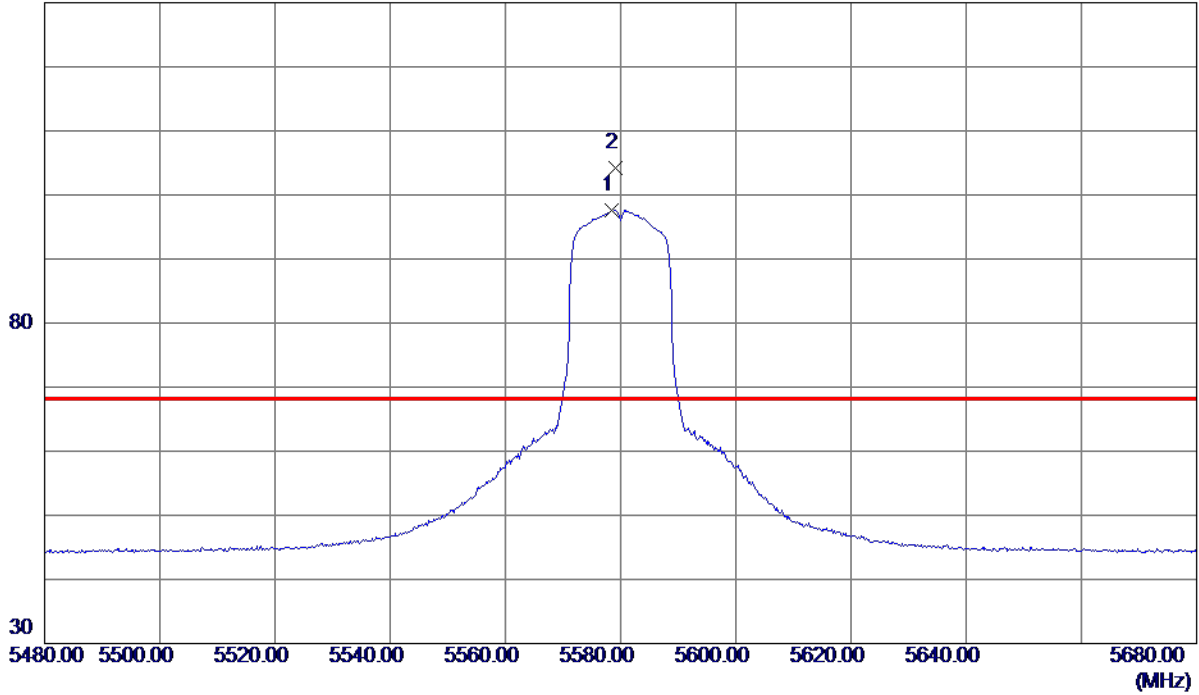

No.	Freq. MHz	Reading Level dBuV/m	Correct Factor dB	Measure ment dBuV/m	Limit dBuV/m	Margin dB	Detector	Comment
1	5578.4000	82.02	15.57	97.59	999.00	-901.41	AVG	No Limit
2 *	5579.2000	88.68	15.57	104.25	68.30	35.95	Peak	No Limit

**REMARKS:**

- (1) Measurement Value = Reading Level + Correct Factor.
- (2) Margin Level = Measurement Value - Limit Value.

Orthogonal Axis	X
Test Mode	UNII-2C_TX A Mode 5580 MHz

### Horizontal

80 dBuV/m

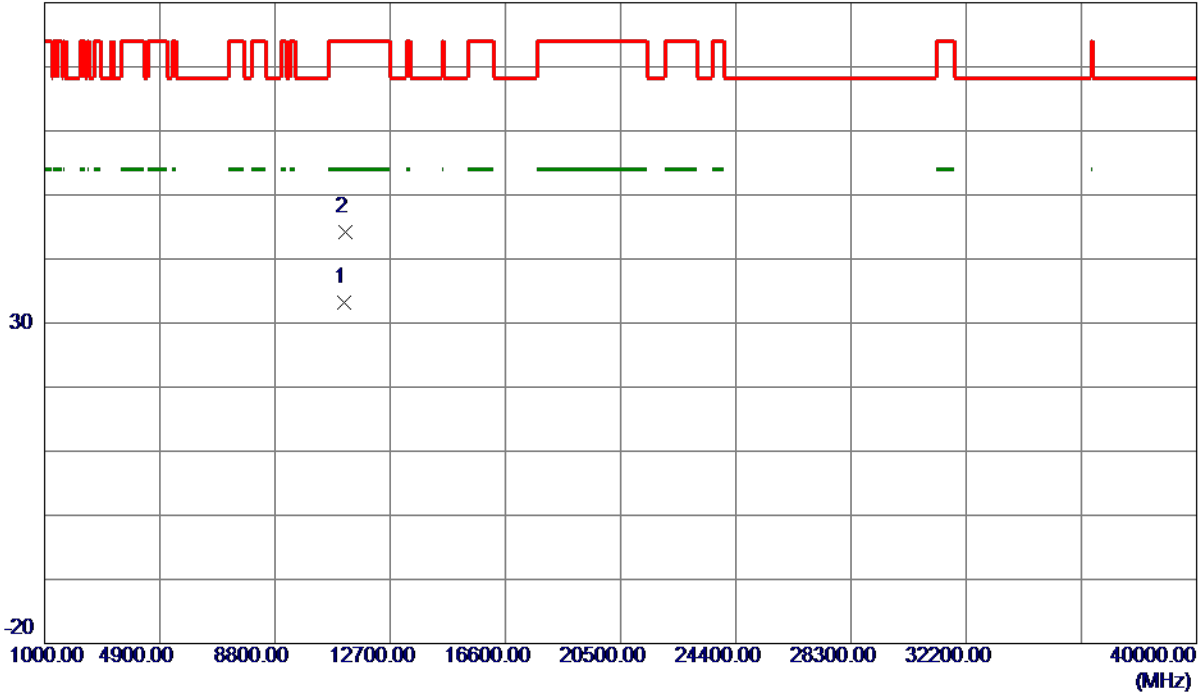

No.	Freq. MHz	Reading Level dBuV/m	Correct Factor dB	Measure ment dBuV/m	Limit dBuV/m	Margin dB	Detector	Comment
1 *	11158.8750	21.46	11.76	33.22	54.00	-20.78	AVG	
2	11166.5750	32.52	11.77	44.29	74.00	-29.71	Peak	

**REMARKS:**

- (1) Measurement Value = Reading Level + Correct Factor.
- (2) Margin Level = Measurement Value - Limit Value.

Orthogonal Axis	X
Test Mode	UNII-2C_TX A Mode 5700 MHz

### Vertical

130 dBuV/m

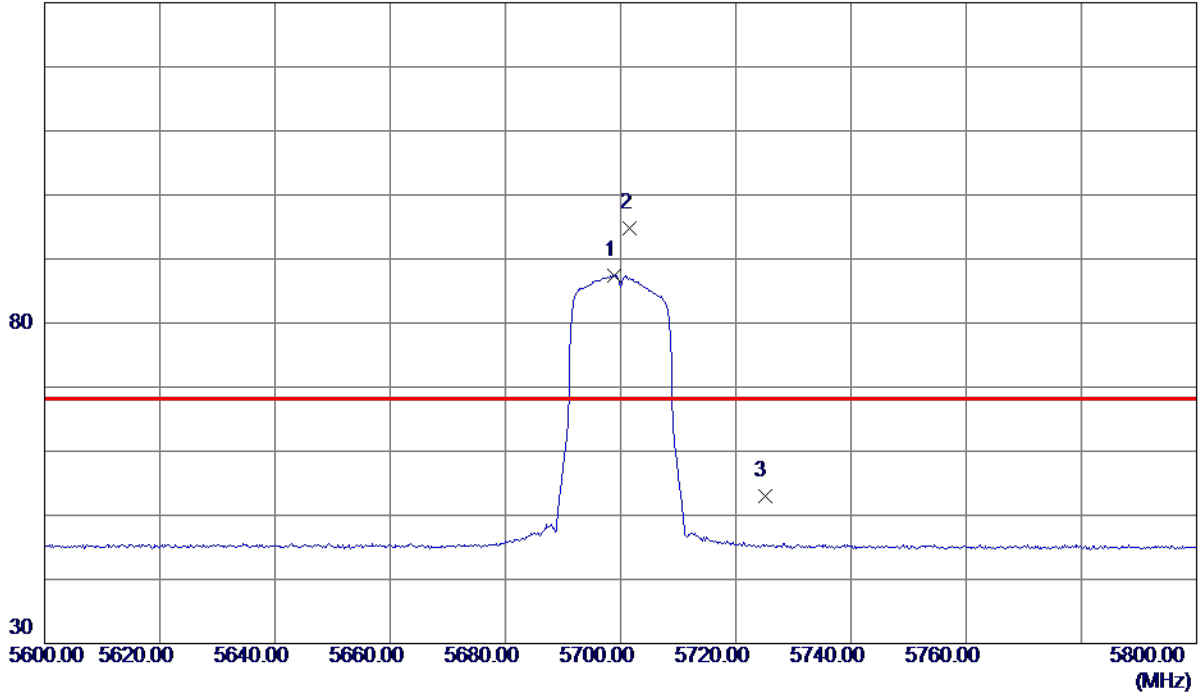

No.	Freq. MHz	Reading Level dBuV/m	Correct Factor dB	Measure ment dBuV/m	Limit dBuV/m	Margin dB	Detector	Comment
1	5698.8000	71.64	15.83	87.47	999.00	-911.53	AVG	No Limit
2 *	5701.6000	78.99	15.83	94.82	68.30	26.52	Peak	No Limit
3	5725.0000	37.09	15.88	52.97	68.30	-15.33	Peak	

**REMARKS:**

- (1) Measurement Value = Reading Level + Correct Factor.
- (2) Margin Level = Measurement Value - Limit Value.

Orthogonal Axis	X
Test Mode	UNII-2C_TX A Mode 5700 MHz

**Vertical**

80 dBuV/m

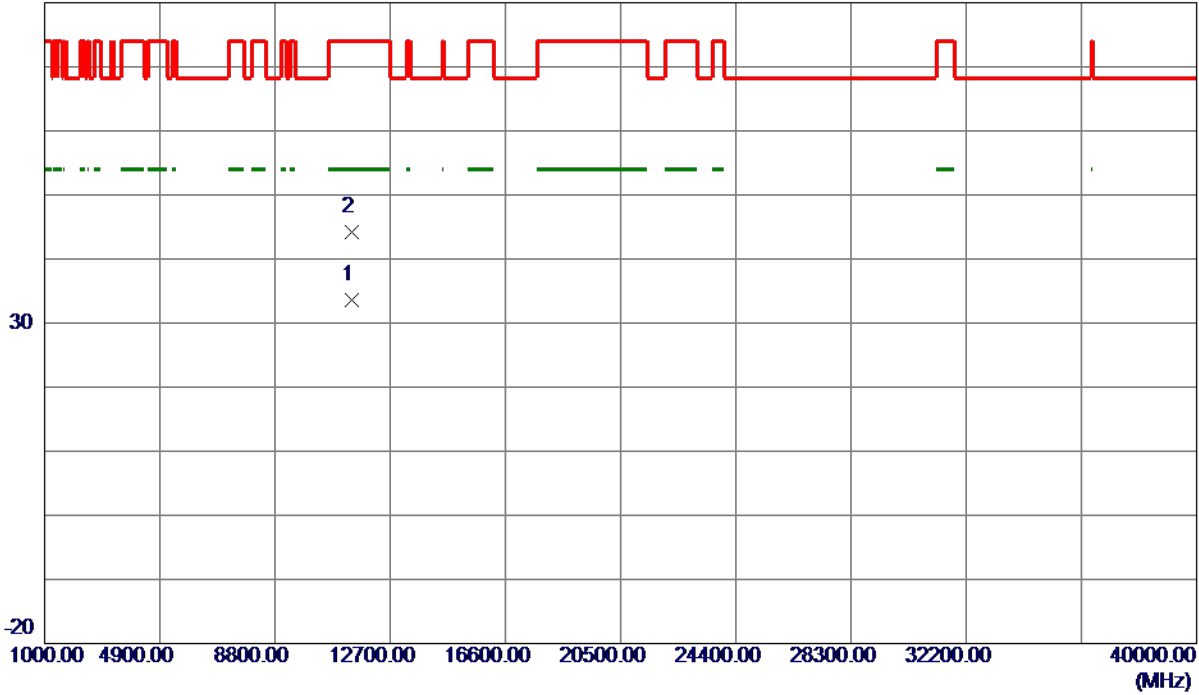

No.	Freq. MHz	Reading Level dBuV/m	Correct Factor dB	Measure ment dBuV/m	Limit dBuV/m	Margin dB	Detector	Comment
1 *	11409.3500	21.53	11.99	33.52	54.00	-20.48	AVG	
2	11410.0500	32.29	11.99	44.28	74.00	-29.72	Peak	

**REMARKS:**

- (1) Measurement Value = Reading Level + Correct Factor.
- (2) Margin Level = Measurement Value - Limit Value.

Orthogonal Axis	X
Test Mode	UNII-2C_TX A Mode 5700 MHz

### Horizontal

130 dBuV/m

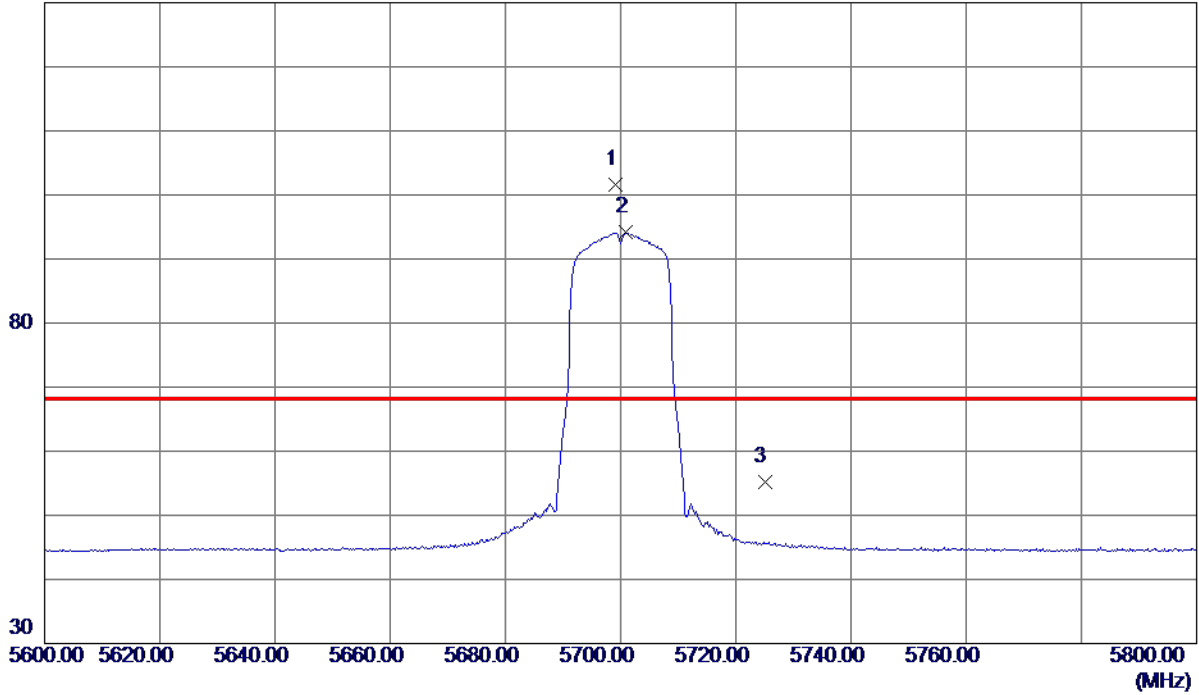

No.	Freq. MHz	Reading Level dBuV/m	Correct Factor dB	Measure ment dBuV/m	Limit dBuV/m	Margin dB	Detector	Comment
1 *	5699.2000	85.79	15.83	101.62	68.30	33.32	Peak	No Limit
2	5700.8000	78.30	15.83	94.13	999.00	-904.87	AVG	No Limit
3	5725.0000	39.39	15.88	55.27	68.30	-13.03	Peak	

**REMARKS:**

- (1) Measurement Value = Reading Level + Correct Factor.
- (2) Margin Level = Measurement Value - Limit Value.

Orthogonal Axis	X
Test Mode	UNII-2C_TX A Mode 5700 MHz

### Horizontal

80 dBuV/m

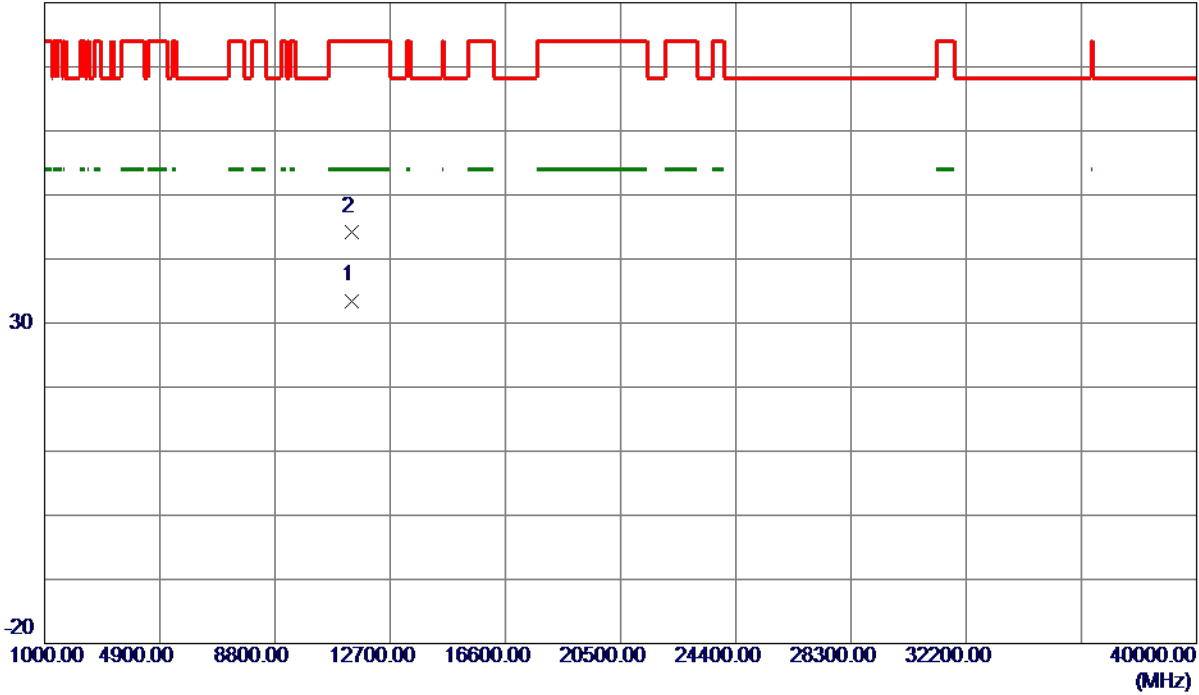

No.	Freq. MHz	Reading Level dBuV/m	Correct Factor dB	Measure ment dBuV/m	Limit dBuV/m	Margin dB	Detector	Comment
1 *	11410.5000	21.51	11.99	33.50	54.00	-20.50	AVG	
2	11419.3750	32.24	12.00	44.24	74.00	-29.76	Peak	

**REMARKS:**

- (1) Measurement Value = Reading Level + Correct Factor.
- (2) Margin Level = Measurement Value - Limit Value.



Orthogonal Axis	X
Test Mode	UNII-2C_TX N (HT20) Mode 5500 MHz

**Vertical**

130 dBuV/m

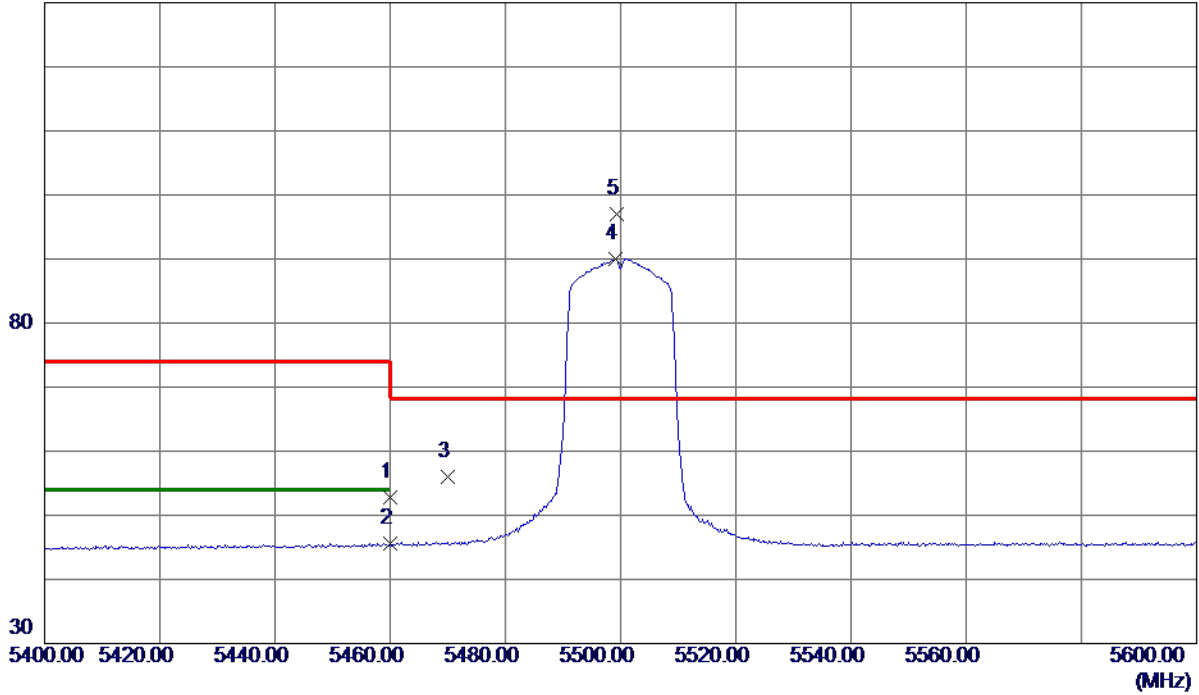

No.	Freq. MHz	Reading Level dBuV/m	Correct Factor dB	Measure ment dBuV/m	Limit dBuV/m	Margin dB	Detector	Comment
1	5460.0000	37.44	15.29	52.73	74.00	-21.27	Peak	
2	5460.0000	30.22	15.29	45.51	54.00	-8.49	AVG	
3	5470.0000	40.70	15.32	56.02	68.30	-12.28	Peak	
4	5499.2000	74.59	15.39	89.98	999.00	-909.02	AVG	No Limit
5 *	5499.4000	81.52	15.39	96.91	68.30	28.61	Peak	No Limit

**REMARKS:**

- (1) Measurement Value = Reading Level + Correct Factor.
- (2) Margin Level = Measurement Value - Limit Value.

Orthogonal Axis	X
Test Mode	UNII-2C_TX N (HT20) Mode 5500 MHz

**Vertical**

80 dBuV/m

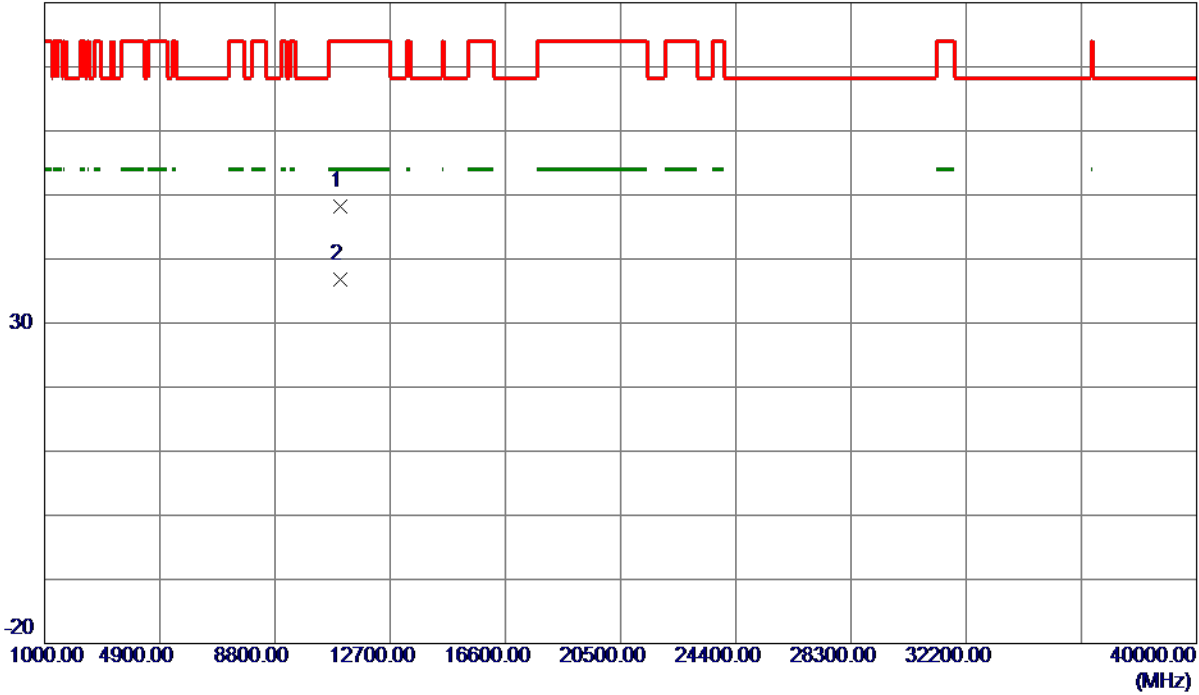

No.	Freq. MHz	Reading Level dBuV/m	Correct Factor dB	Measure ment dBuV/m	Limit dBuV/m	Margin dB	Detector	Comment
1	11000.0000	34.80	13.49	48.29	74.00	-25.71	Peak	
2 *	11000.0000	23.30	13.49	36.79	54.00	-17.21	AVG	

**REMARKS:**

- (1) Measurement Value = Reading Level + Correct Factor.
- (2) Margin Level = Measurement Value - Limit Value.

Orthogonal Axis	X
Test Mode	UNII-2C_TX N (HT20) Mode 5500 MHz

### Horizontal

130 dBuV/m

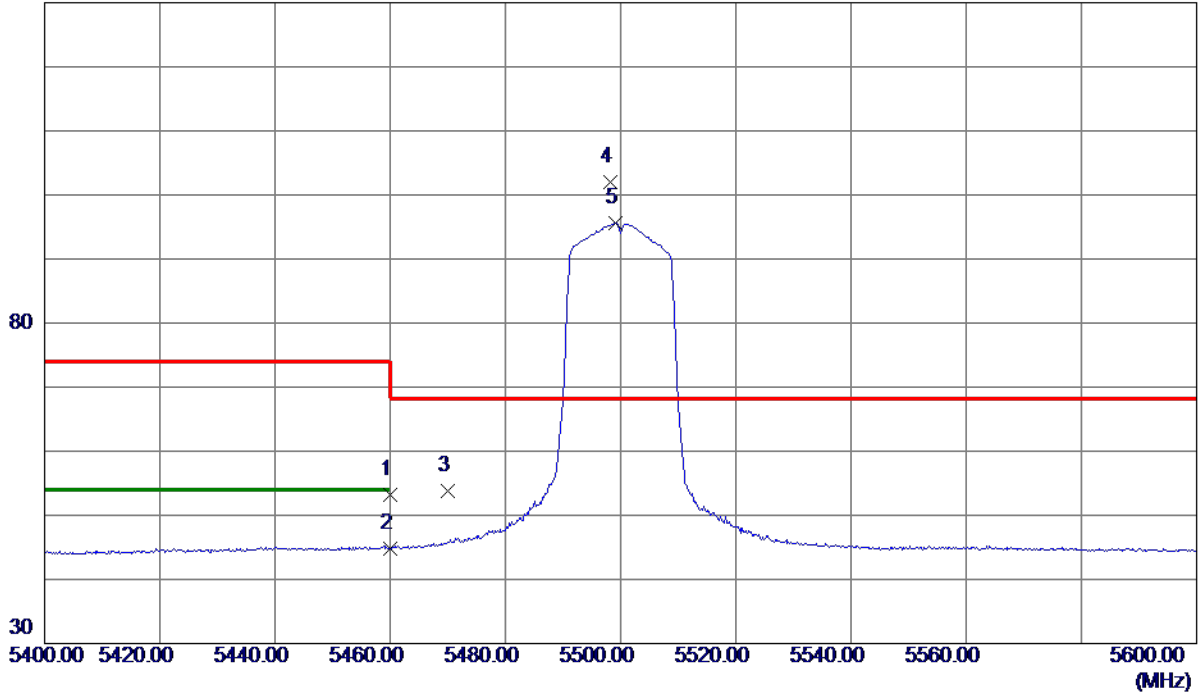

No.	Freq. MHz	Reading Level dBuV/m	Correct Factor dB	Measure ment dBuV/m	Limit dBuV/m	Margin dB	Detector	Comment
1	5460.0000	37.89	15.29	53.18	74.00	-20.82	Peak	
2	5460.0000	29.50	15.29	44.79	54.00	-9.21	AVG	
3	5470.0000	38.42	15.32	53.74	68.30	-14.56	Peak	
4 *	5498.2000	86.71	15.39	102.10	68.30	33.80	Peak	No Limit
5	5499.2000	80.24	15.39	95.63	999.00	-903.37	AVG	No Limit

**REMARKS:**

- (1) Measurement Value = Reading Level + Correct Factor.
- (2) Margin Level = Measurement Value - Limit Value.

Orthogonal Axis	X
Test Mode	UNII-2C_TX N (HT20) Mode 5500 MHz

### Horizontal

80 dBuV/m

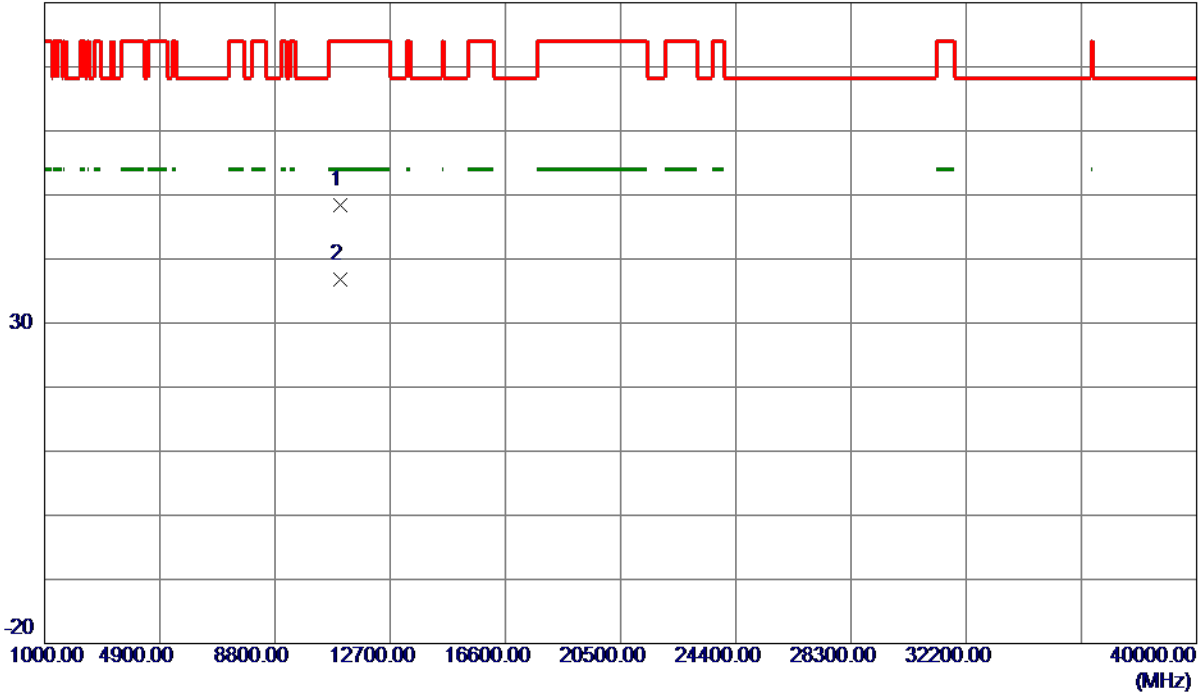

No.	Freq. MHz	Reading Level dBuV/m	Correct Factor dB	Measure ment dBuV/m	Limit dBuV/m	Margin dB	Detector	Comment
1	11000.0000	34.87	13.49	48.36	74.00	-25.64	Peak	
2 *	11000.0000	23.27	13.49	36.76	54.00	-17.24	AVG	

**REMARKS:**

- (1) Measurement Value = Reading Level + Correct Factor.
- (2) Margin Level = Measurement Value - Limit Value.

Orthogonal Axis	X
Test Mode	UNII-2C_TX N (HT20) Mode 5580 MHz

**Vertical**

130 dBuV/m

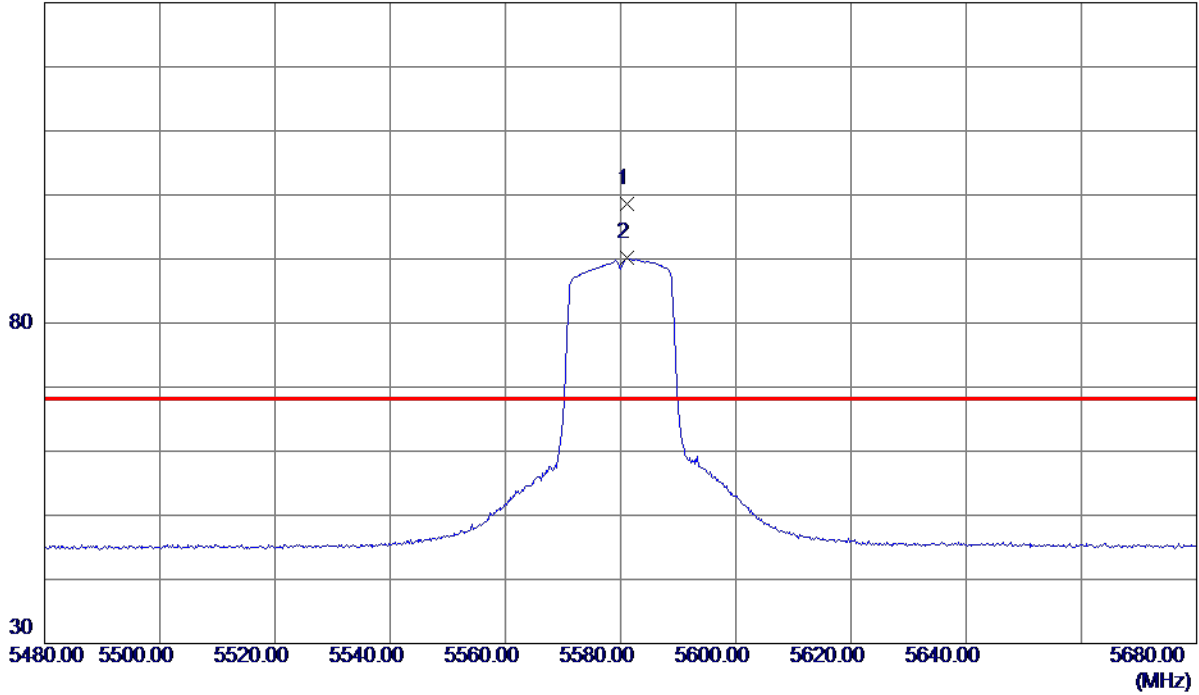

No.	Freq. MHz	Reading Level dBuV/m	Correct Factor dB	Measure ment dBuV/m	Limit dBuV/m	Margin dB	Detector	Comment
1 *	5581.2000	82.95	15.57	98.52	68.30	30.22	Peak	No Limit
2	5581.2000	74.56	15.57	90.13	999.00	-908.87	AVG	No Limit

**REMARKS:**

- (1) Measurement Value = Reading Level + Correct Factor.
- (2) Margin Level = Measurement Value - Limit Value.

Orthogonal Axis	X
Test Mode	UNII-2C_TX N (HT20) Mode 5580 MHz

**Vertical**

80 dBuV/m

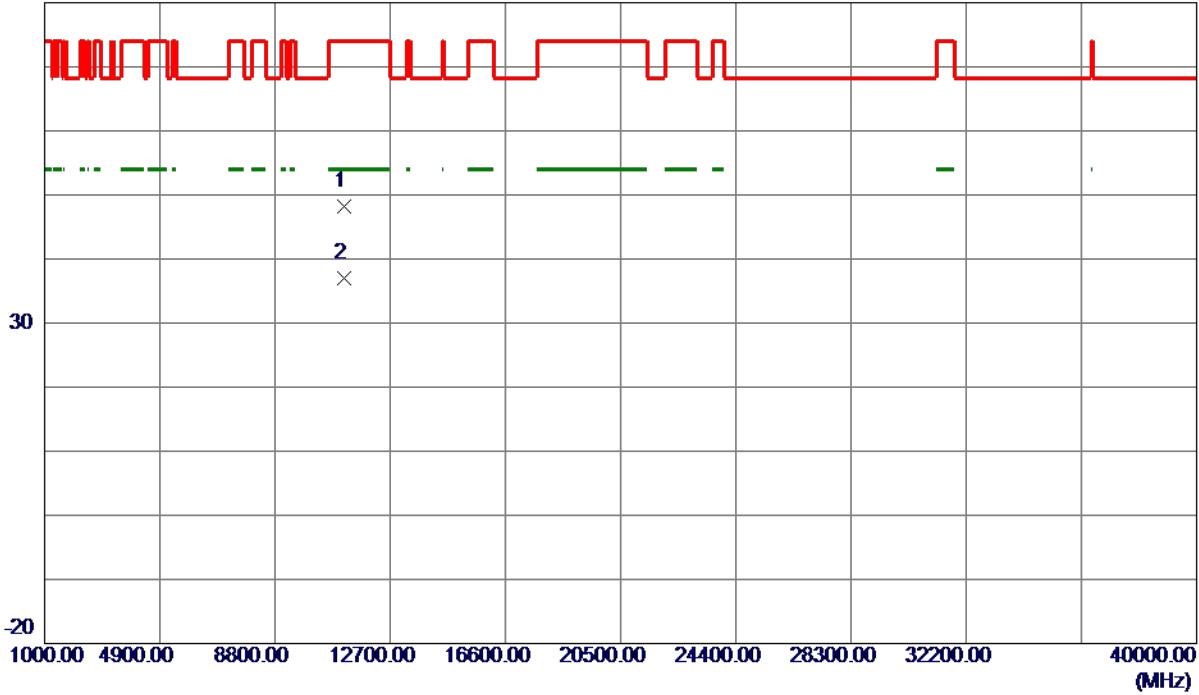

No.	Freq. MHz	Reading Level dBuV/m	Correct Factor dB	Measure ment dBuV/m	Limit dBuV/m	Margin dB	Detector	Comment
1	11160.0000	34.57	13.68	48.25	74.00	-25.75	Peak	
2 *	11160.0000	23.35	13.68	37.03	54.00	-16.97	AVG	

**REMARKS:**

- (1) Measurement Value = Reading Level + Correct Factor.
- (2) Margin Level = Measurement Value - Limit Value.

Orthogonal Axis	X
Test Mode	UNII-2C_TX N (HT20) Mode 5580 MHz

### Horizontal

130 dBuV/m

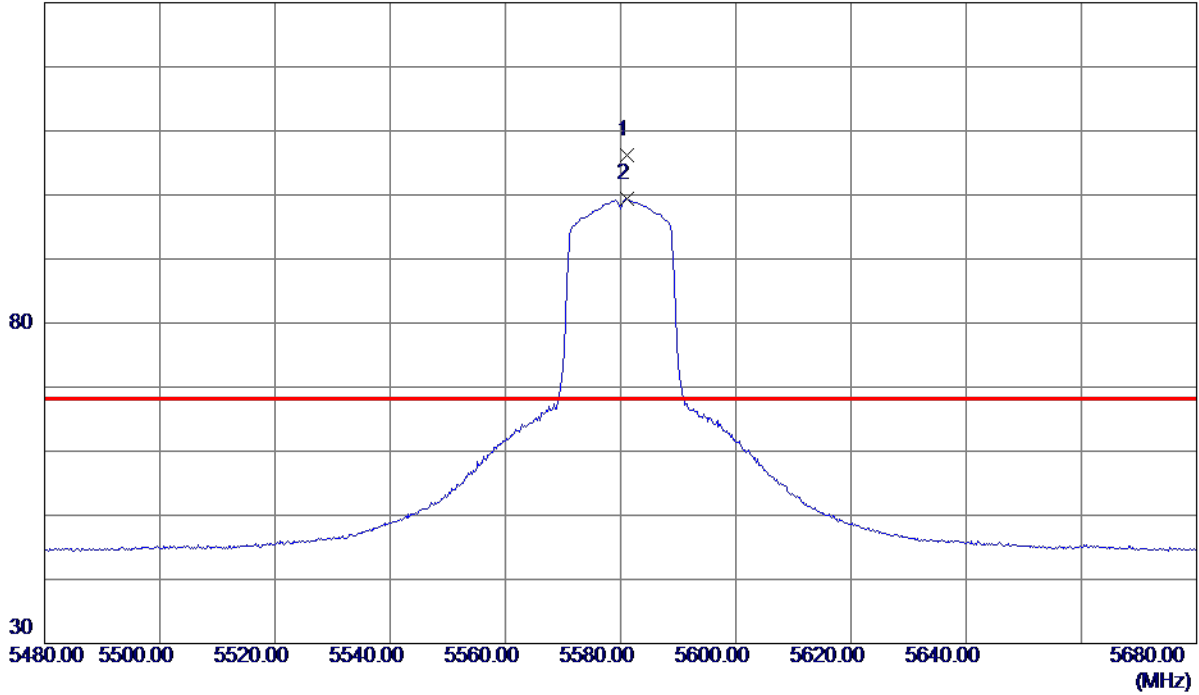

No.	Freq. MHz	Reading Level dBuV/m	Correct Factor dB	Measure ment dBuV/m	Limit dBuV/m	Margin dB	Detector	Comment
1 *	5581.2000	90.55	15.57	106.12	68.30	37.82	Peak	No Limit
2	5581.2000	83.82	15.57	99.39	999.00	-899.61	AVG	No Limit

**REMARKS:**

- (1) Measurement Value = Reading Level + Correct Factor.
- (2) Margin Level = Measurement Value - Limit Value.

Orthogonal Axis	X
Test Mode	UNII-2C_TX N (HT20) Mode 5580 MHz

### Horizontal

80 dBuV/m

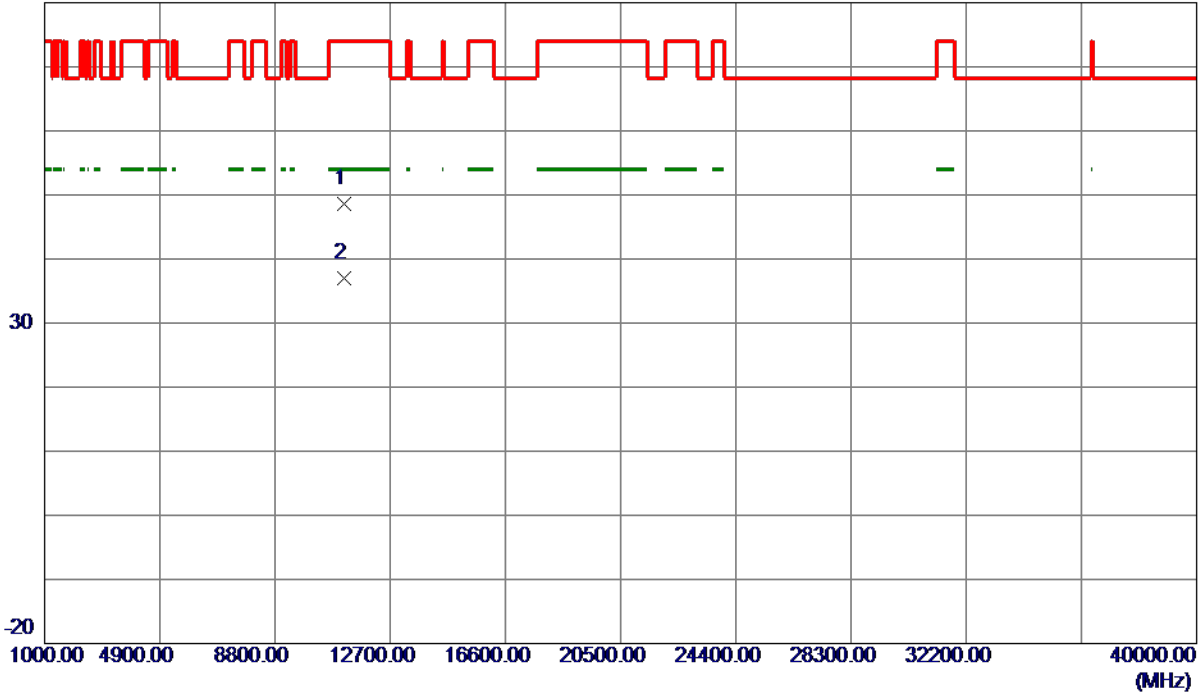

No.	Freq. MHz	Reading Level dBuV/m	Correct Factor dB	Measure ment dBuV/m	Limit dBuV/m	Margin dB	Detector	Comment
1	11160.0000	34.86	13.68	48.54	74.00	-25.46	Peak	
2 *	11160.0000	23.37	13.68	37.05	54.00	-16.95	AVG	

**REMARKS:**

- (1) Measurement Value = Reading Level + Correct Factor.
- (2) Margin Level = Measurement Value - Limit Value.



Orthogonal Axis	X
Test Mode	UNII-2C_TX N (HT20) Mode 5700 MHz

**Vertical**

130 dBuV/m

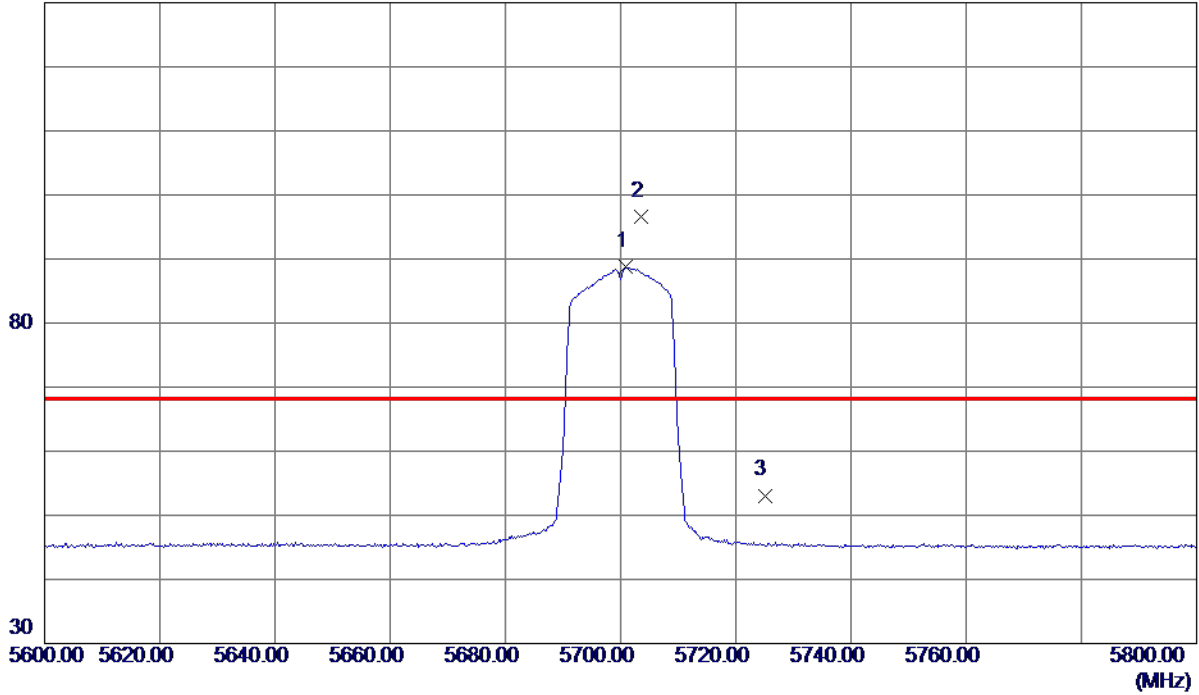

No.	Freq. MHz	Reading Level dBuV/m	Correct Factor dB	Measure ment dBuV/m	Limit dBuV/m	Margin dB	Detector	Comment
1	5700.8000	72.94	15.83	88.77	999.00	-910.23	AVG	No Limit
2 *	5703.6000	80.79	15.84	96.63	68.30	28.33	Peak	No Limit
3	5725.0000	37.22	15.88	53.10	68.30	-15.20	Peak	

**REMARKS:**

- (1) Measurement Value = Reading Level + Correct Factor.
- (2) Margin Level = Measurement Value - Limit Value.

Orthogonal Axis	X
Test Mode	UNII-2C_TX N (HT20) Mode 5700 MHz

**Vertical**

80 dBuV/m

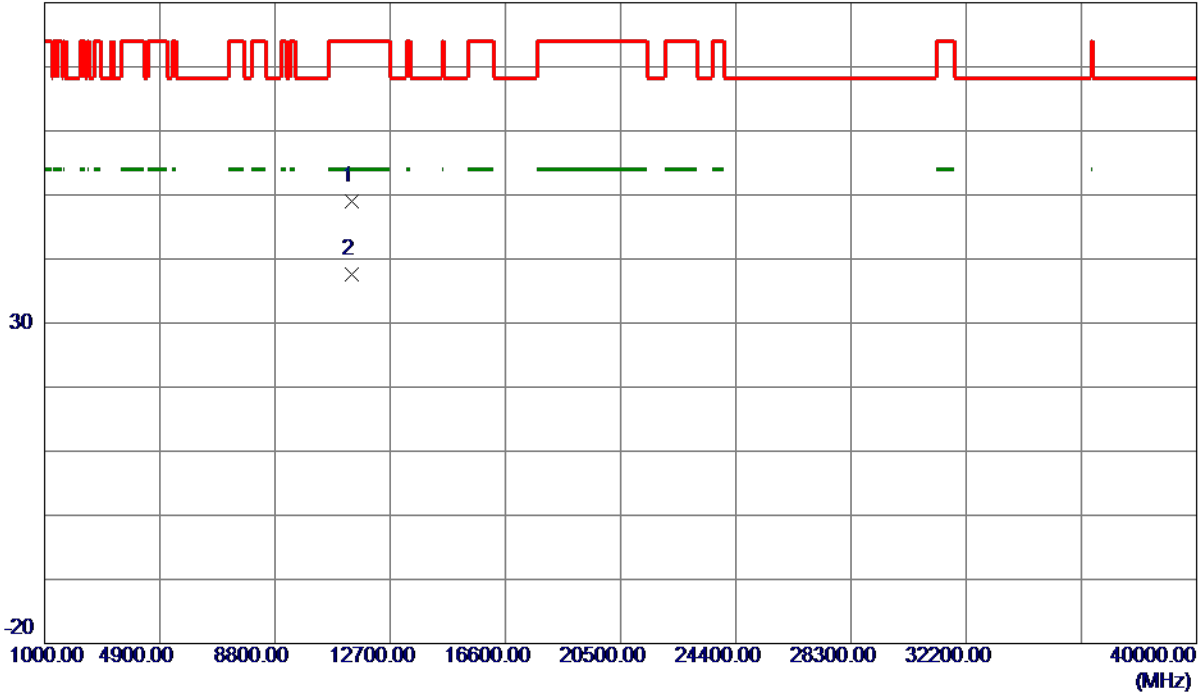

No.	Freq. MHz	Reading Level dBuV/m	Correct Factor dB	Measure ment dBuV/m	Limit dBuV/m	Margin dB	Detector	Comment
1	11400.0000	35.12	13.97	49.09	74.00	-24.91	Peak	
2 *	11400.0000	23.59	13.97	37.56	54.00	-16.44	AVG	

**REMARKS:**

- (1) Measurement Value = Reading Level + Correct Factor.
- (2) Margin Level = Measurement Value - Limit Value.

Orthogonal Axis	X
Test Mode	UNII-2C_TX N (HT20) Mode 5700 MHz

### Horizontal

130 dBuV/m

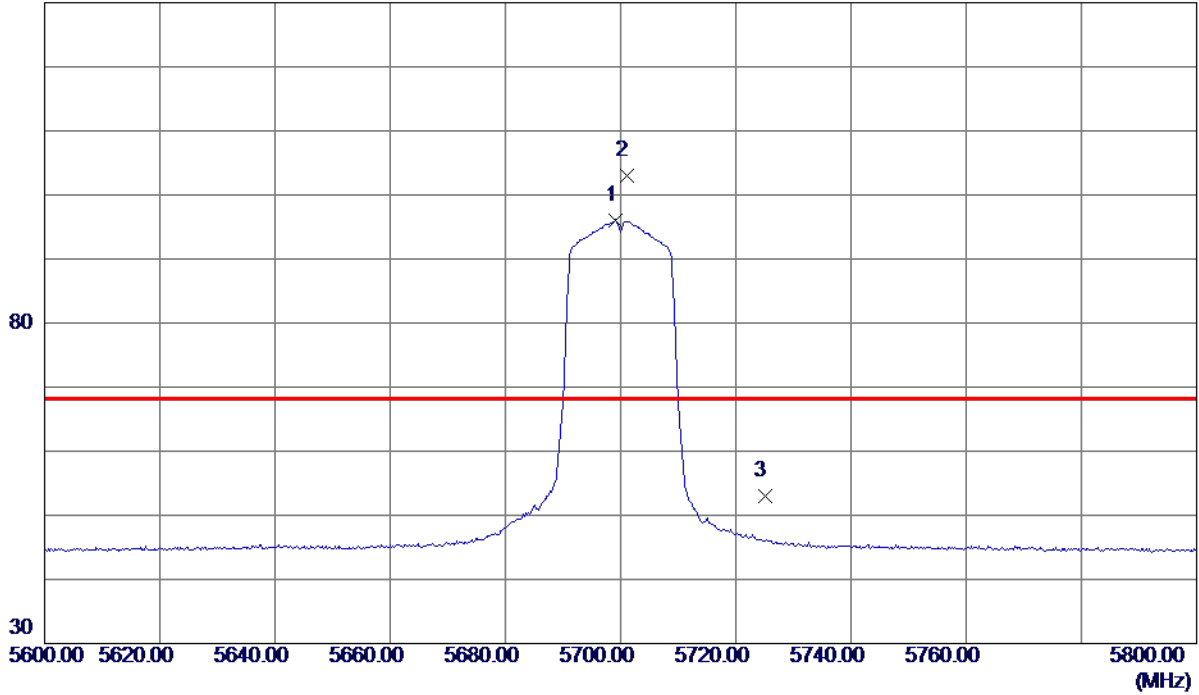

No.	Freq. MHz	Reading Level dBuV/m	Correct Factor dB	Measure ment dBuV/m	Limit dBuV/m	Margin dB	Detector	Comment
1	5699.2000	80.27	15.83	96.10	999.00	-902.90	AVG	No Limit
2 *	5701.0000	87.23	15.83	103.06	68.30	34.76	Peak	No Limit
3	5725.0000	37.10	15.88	52.98	68.30	-15.32	Peak	

**REMARKS:**

- (1) Measurement Value = Reading Level + Correct Factor.
- (2) Margin Level = Measurement Value - Limit Value.

Orthogonal Axis	X
Test Mode	UNII-2C_TX N (HT20) Mode 5700 MHz

### Horizontal

80 dBuV/m

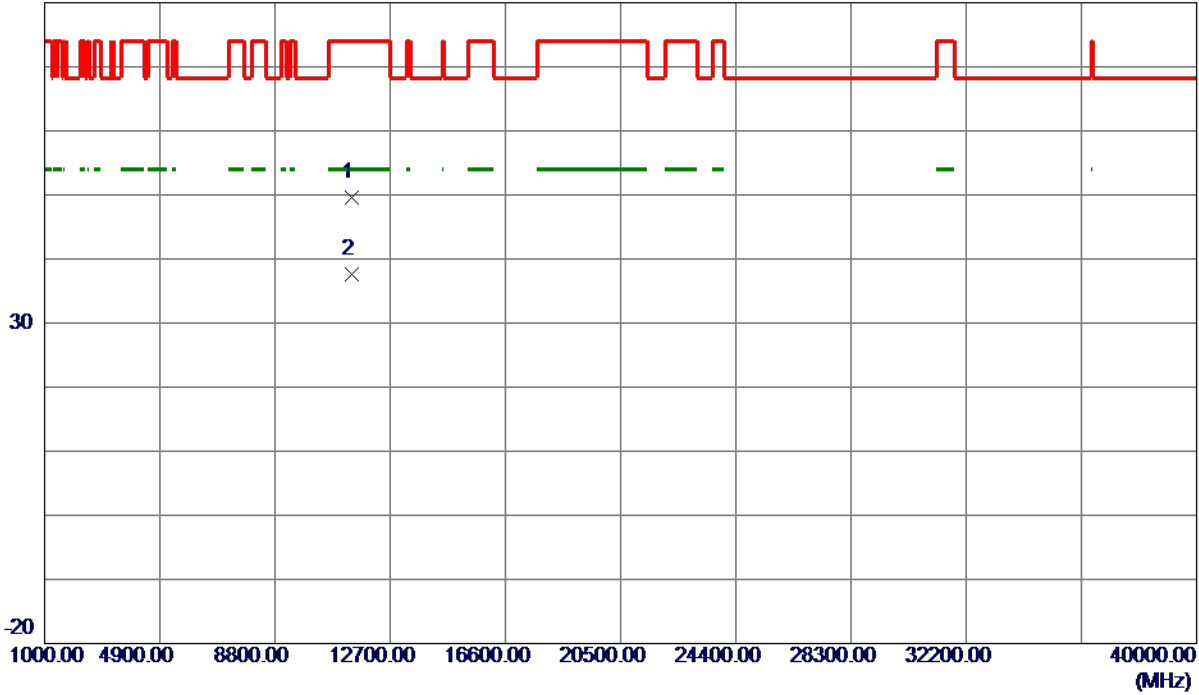

No.	Freq. MHz	Reading Level dBuV/m	Correct Factor dB	Measure ment dBuV/m	Limit dBuV/m	Margin dB	Detector	Comment
1	11400.0000	35.54	13.97	49.51	74.00	-24.49	Peak	
2 *	11400.0000	23.58	13.97	37.55	54.00	-16.45	AVG	

**REMARKS:**

- (1) Measurement Value = Reading Level + Correct Factor.
- (2) Margin Level = Measurement Value - Limit Value.

Orthogonal Axis	X
Test Mode	UNII-2C_TX N (HT40) Mode 5510 MHz

### Vertical

130 dBuV/m

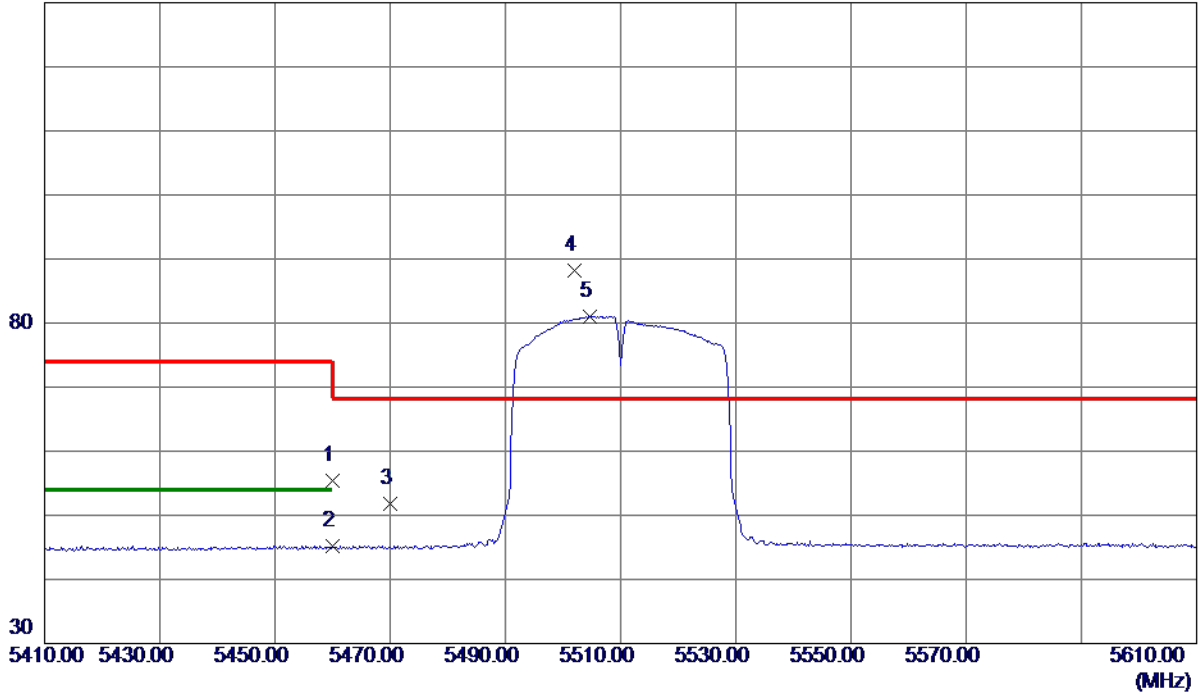

No.	Freq. MHz	Reading Level dBuV/m	Correct Factor dB	Measure ment dBuV/m	Limit dBuV/m	Margin dB	Detector	Comment
1	5460.0000	40.12	15.29	55.41	74.00	-18.59	Peak	
2	5460.0000	29.94	15.29	45.23	54.00	-8.77	AVG	
3	5470.0000	36.42	15.32	51.74	68.30	-16.56	Peak	
4 *	5502.0000	72.73	15.40	88.13	68.30	19.83	Peak	No Limit
5	5504.6000	65.62	15.41	81.03	999.00	-917.97	AVG	No Limit

**REMARKS:**

- (1) Measurement Value = Reading Level + Correct Factor.
- (2) Margin Level = Measurement Value - Limit Value.

Orthogonal Axis	X
Test Mode	UNII-2C_TX N (HT40) Mode 5510 MHz

**Vertical**

80 dBuV/m

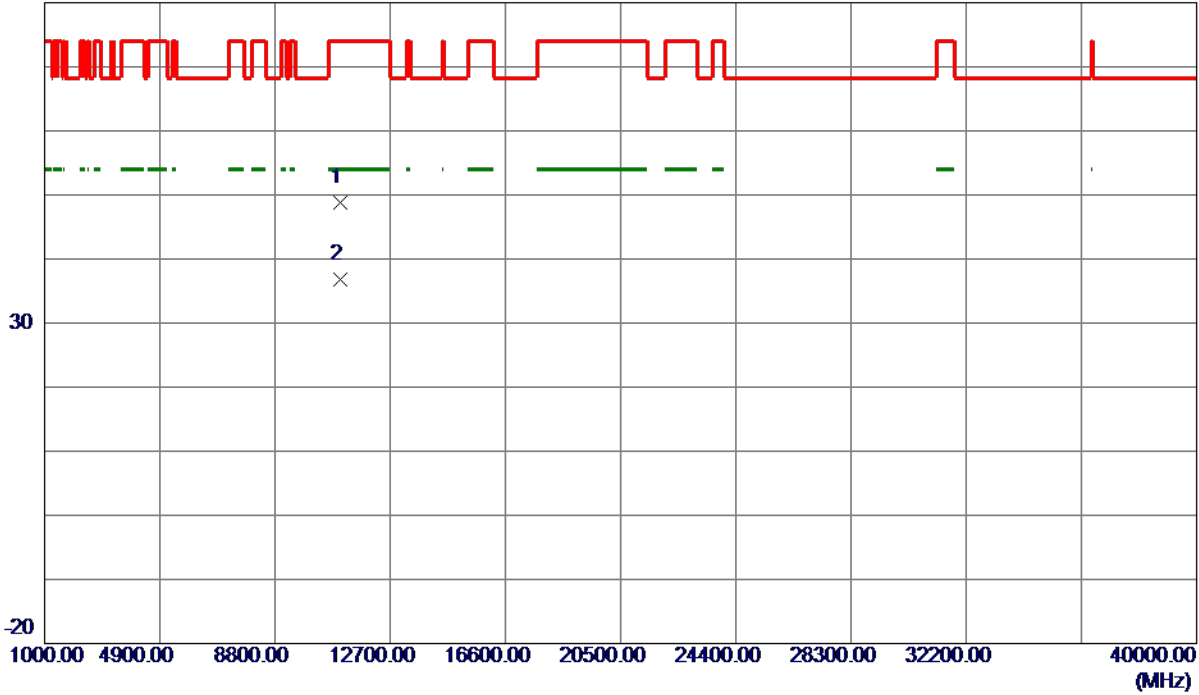

No.	Freq. MHz	Reading Level dBuV/m	Correct Factor dB	Measure ment dBuV/m	Limit dBuV/m	Margin dB	Detector	Comment
1	11020.0000	35.37	13.51	48.88	74.00	-25.12	Peak	
2 *	11020.0000	23.23	13.51	36.74	54.00	-17.26	AVG	

**REMARKS:**

- (1) Measurement Value = Reading Level + Correct Factor.
- (2) Margin Level = Measurement Value - Limit Value.

Orthogonal Axis	X
Test Mode	UNII-2C_TX N (HT40) Mode 5510 MHz

### Horizontal

130 dBuV/m

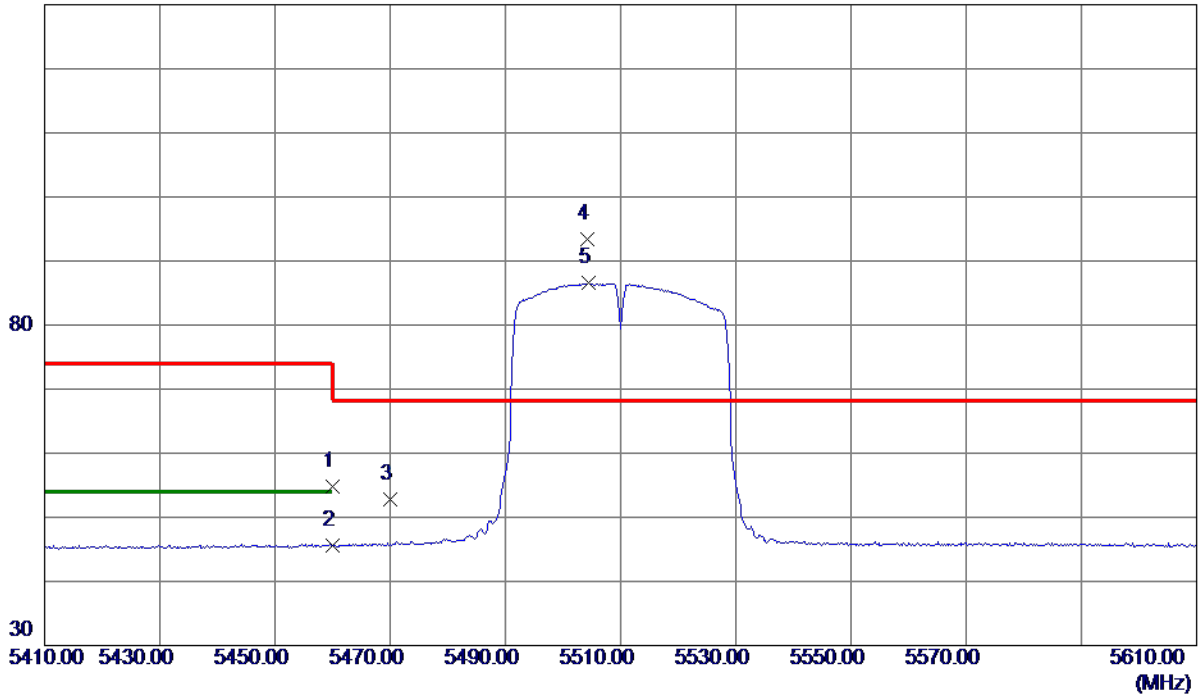

No.	Freq. MHz	Reading Level dBuV/m	Correct Factor dB	Measure ment dBuV/m	Limit dBuV/m	Margin dB	Detector	Comment
1	5460.0000	39.45	15.29	54.74	74.00	-19.26	Peak	
2	5460.0000	30.24	15.29	45.53	54.00	-8.47	AVG	
3	5470.0000	37.48	15.32	52.80	68.30	-15.50	Peak	
4 *	5504.2000	77.91	15.40	93.31	68.30	25.01	Peak	No Limit
5	5504.4000	71.11	15.40	86.51	999.00	-912.49	AVG	No Limit

**REMARKS:**

- (1) Measurement Value = Reading Level + Correct Factor.
- (2) Margin Level = Measurement Value - Limit Value.

Orthogonal Axis	X
Test Mode	UNII-2C_TX N (HT40) Mode 5510 MHz

### Horizontal

80 dBuV/m

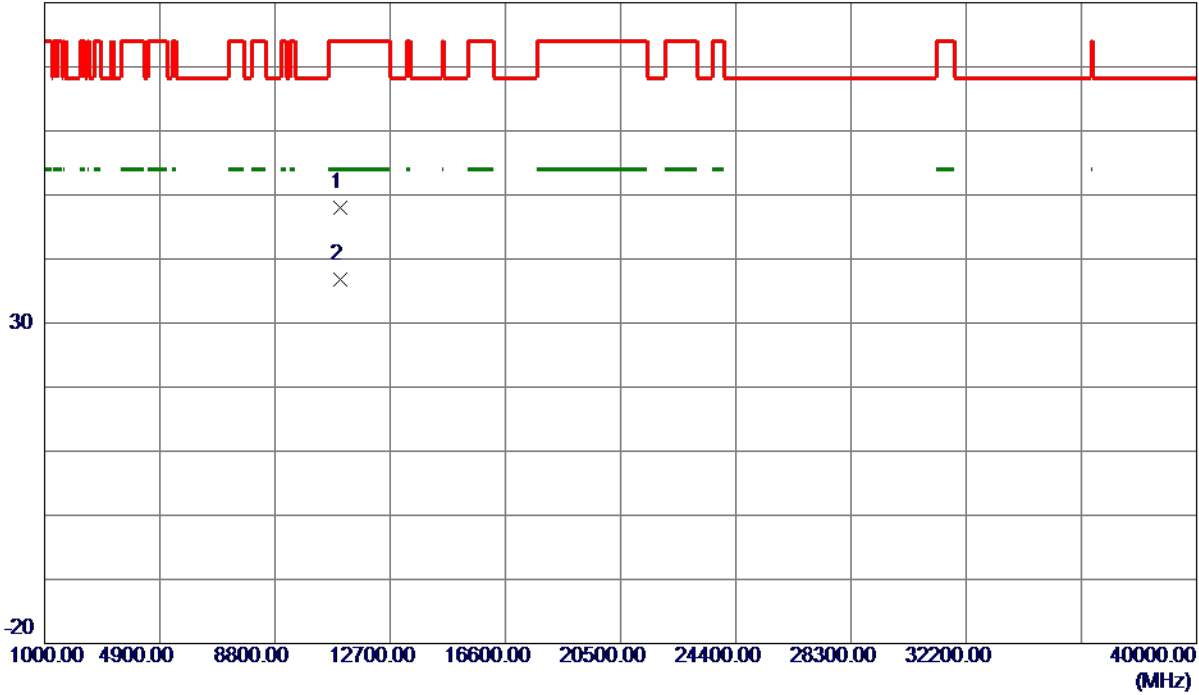

No.	Freq. MHz	Reading Level dBuV/m	Correct Factor dB	Measure ment dBuV/m	Limit dBuV/m	Margin dB	Detector	Comment
1	11020.0000	34.57	13.51	48.08	74.00	-25.92	Peak	
2 *	11020.0000	23.35	13.51	36.86	54.00	-17.14	AVG	

**REMARKS:**

- (1) Measurement Value = Reading Level + Correct Factor.
- (2) Margin Level = Measurement Value - Limit Value.



Orthogonal Axis	X
Test Mode	UNII-2C_TX N (HT40) Mode 5550 MHz

**Vertical**

130 dBuV/m

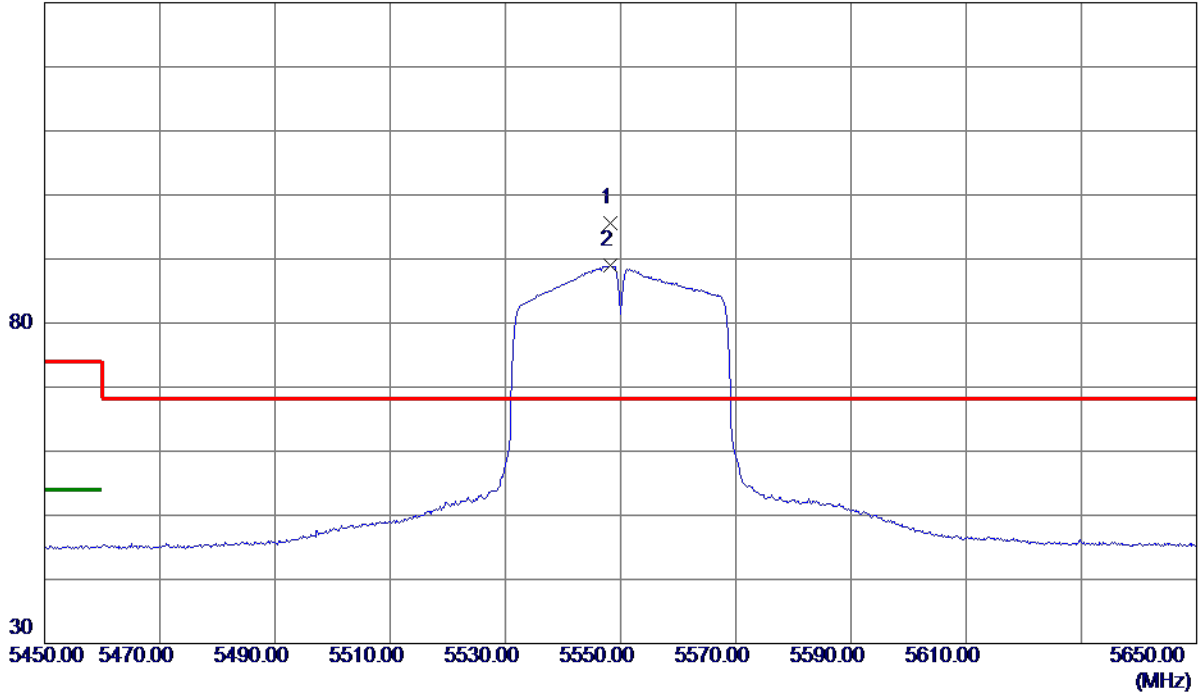

No.	Freq. MHz	Reading Level dBuV/m	Correct Factor dB	Measure ment dBuV/m	Limit dBuV/m	Margin dB	Detector	Comment
1 *	5548.2000	80.14	15.50	95.64	68.30	27.34	Peak	No Limit
2	5548.2000	73.44	15.50	88.94	999.00	-910.06	AVG	No Limit

**REMARKS:**

- (1) Measurement Value = Reading Level + Correct Factor.
- (2) Margin Level = Measurement Value - Limit Value.

Orthogonal Axis	X
Test Mode	UNII-2C_TX N (HT40) Mode 5550 MHz

**Vertical**

80 dBuV/m

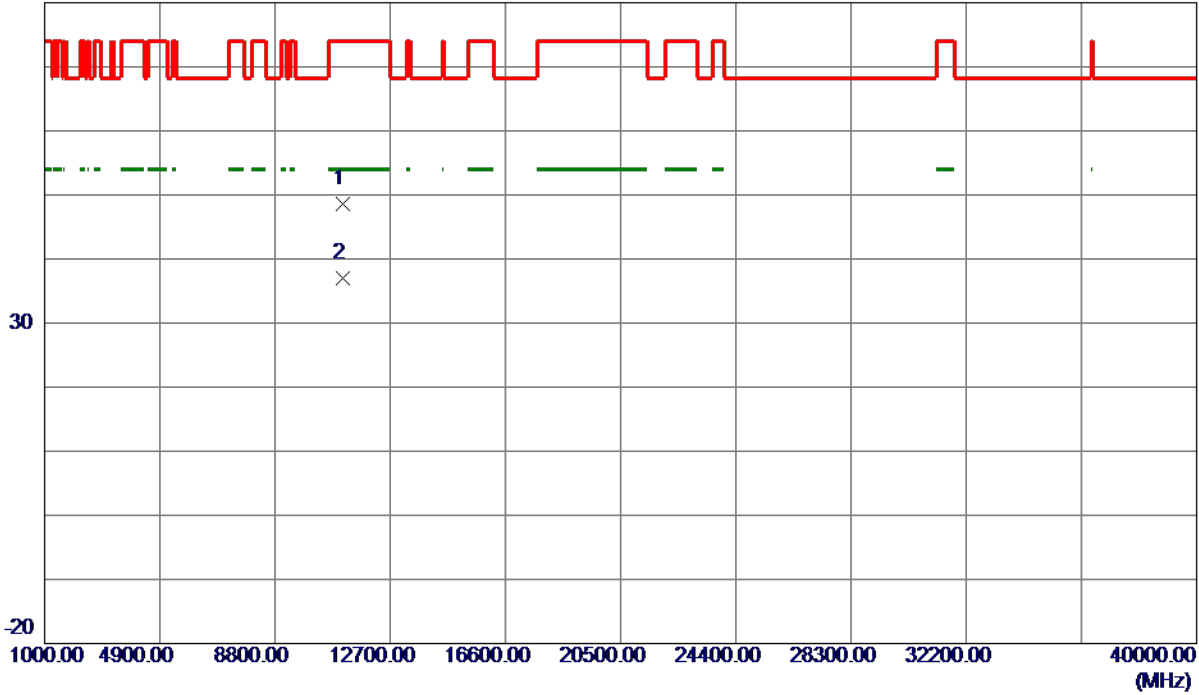

No.	Freq. MHz	Reading Level dBuV/m	Correct Factor dB	Measure ment dBuV/m	Limit dBuV/m	Margin dB	Detector	Comment
1	11100.0000	34.96	13.61	48.57	74.00	-25.43	Peak	
2 *	11100.0000	23.41	13.61	37.02	54.00	-16.98	AVG	

**REMARKS:**

- (1) Measurement Value = Reading Level + Correct Factor.
- (2) Margin Level = Measurement Value - Limit Value.

Orthogonal Axis	X
Test Mode	UNII-2C_TX N (HT40) Mode 5550 MHz

### Horizontal

130 dBuV/m

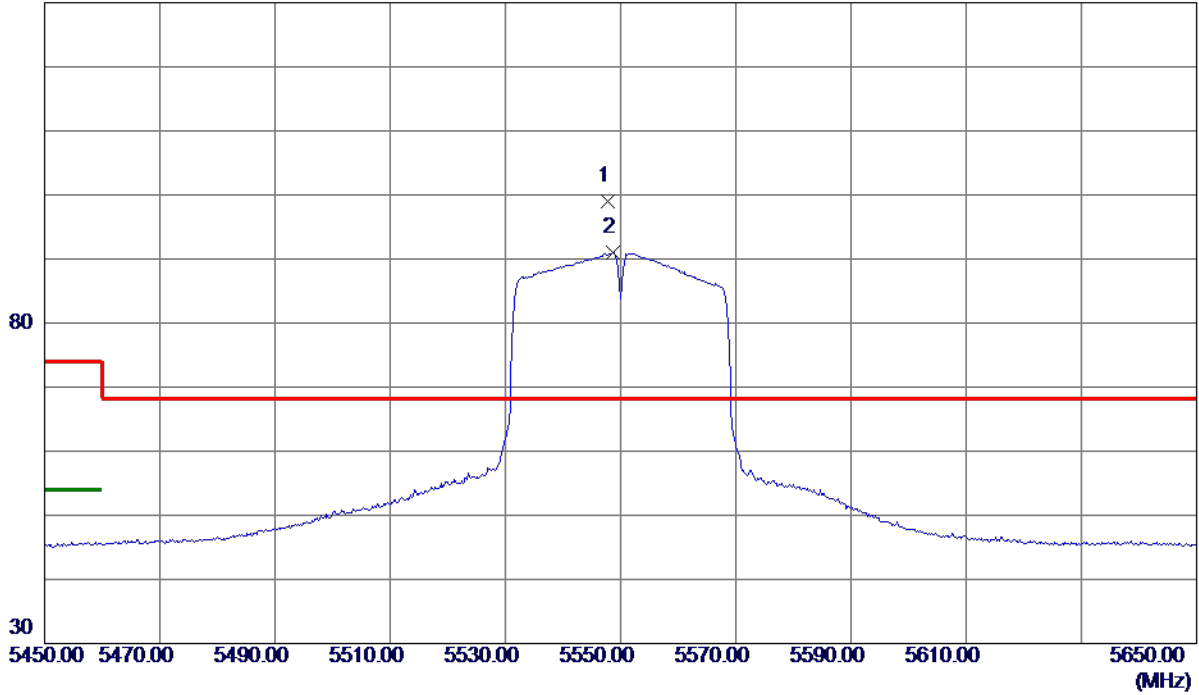

No.	Freq. MHz	Reading Level dBuV/m	Correct Factor dB	Measure ment dBuV/m	Limit dBuV/m	Margin dB	Detector	Comment
1 *	5547.8000	83.44	15.50	98.94	68.30	30.64	Peak	No Limit
2	5548.6000	75.49	15.50	90.99	999.00	-908.01	AVG	No Limit

**REMARKS:**

- (1) Measurement Value = Reading Level + Correct Factor.
- (2) Margin Level = Measurement Value - Limit Value.

Orthogonal Axis	X
Test Mode	UNII-2C_TX N (HT40) Mode 5550 MHz

### Horizontal

80 dBuV/m

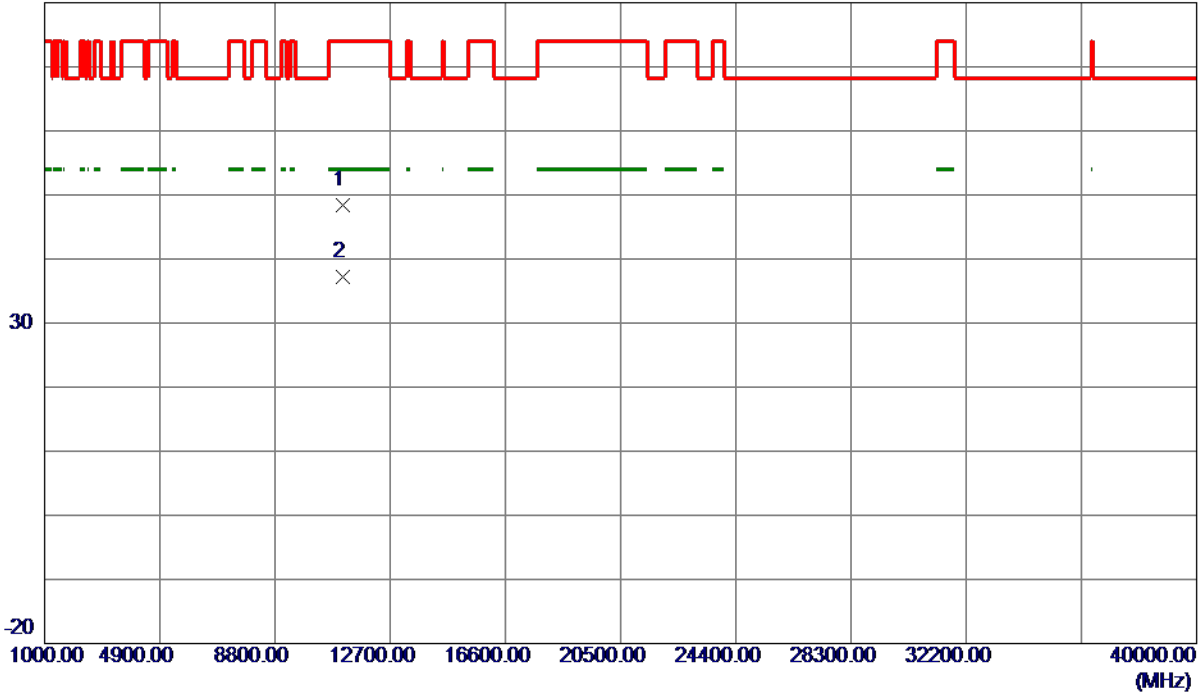

No.	Freq. MHz	Reading Level dBuV/m	Correct Factor dB	Measure ment dBuV/m	Limit dBuV/m	Margin dB	Detector	Comment
1	11100.0000	34.82	13.61	48.43	74.00	-25.57	Peak	
2 *	11100.0000	23.53	13.61	37.14	54.00	-16.86	AVG	

**REMARKS:**

- (1) Measurement Value = Reading Level + Correct Factor.
- (2) Margin Level = Measurement Value - Limit Value.

Orthogonal Axis	X
Test Mode	UNII-2C_TX N (HT40) Mode 5670 MHz

**Vertical**

130 dBuV/m

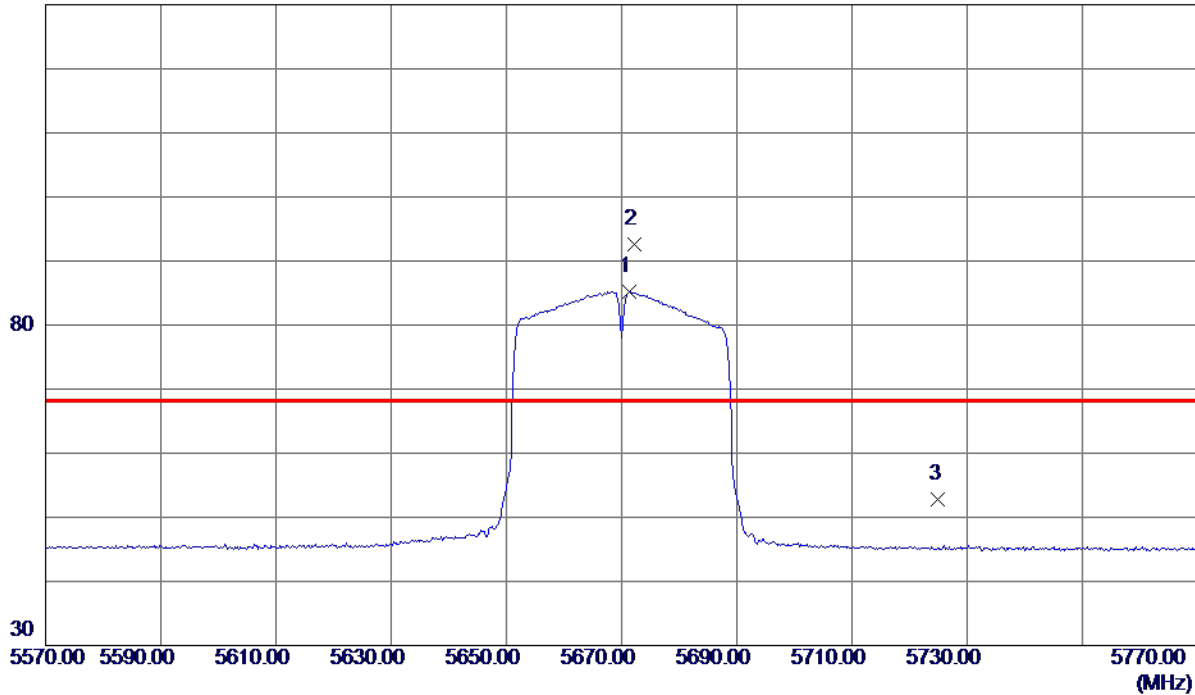

No.	Freq. MHz	Reading Level dBuV/m	Correct Factor dB	Measure ment dBuV/m	Limit dBuV/m	Margin dB	Detector	Comment
1	5671.4000	69.35	15.77	85.12	999.00	-913.88	AVG	No Limit
2 *	5672.2000	76.87	15.77	92.64	68.30	24.34	Peak	No Limit
3	5725.0000	36.83	15.88	52.71	68.30	-15.59	Peak	

**REMARKS:**

- (1) Measurement Value = Reading Level + Correct Factor.
- (2) Margin Level = Measurement Value - Limit Value.

Orthogonal Axis	X
Test Mode	UNII-2C_TX N (HT40) Mode 5670 MHz

**Vertical**

80 dBuV/m

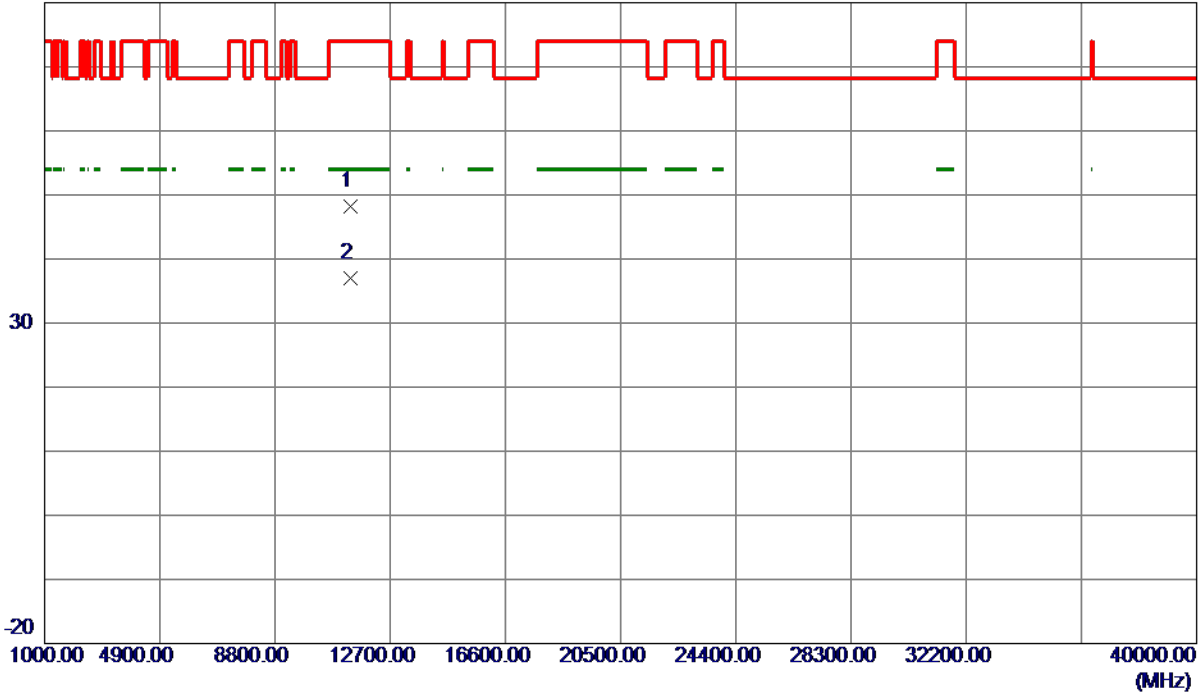

No.	Freq. MHz	Reading Level dBuV/m	Correct Factor dB	Measure ment dBuV/m	Limit dBuV/m	Margin dB	Detector	Comment
1	11340.0000	34.26	13.90	48.16	74.00	-25.84	Peak	
2 *	11340.0000	23.18	13.90	37.08	54.00	-16.92	AVG	

**REMARKS:**

- (1) Measurement Value = Reading Level + Correct Factor.
- (2) Margin Level = Measurement Value - Limit Value.

Orthogonal Axis	X
Test Mode	UNII-2C_TX N (HT40) Mode 5670 MHz

### Horizontal

130 dBuV/m

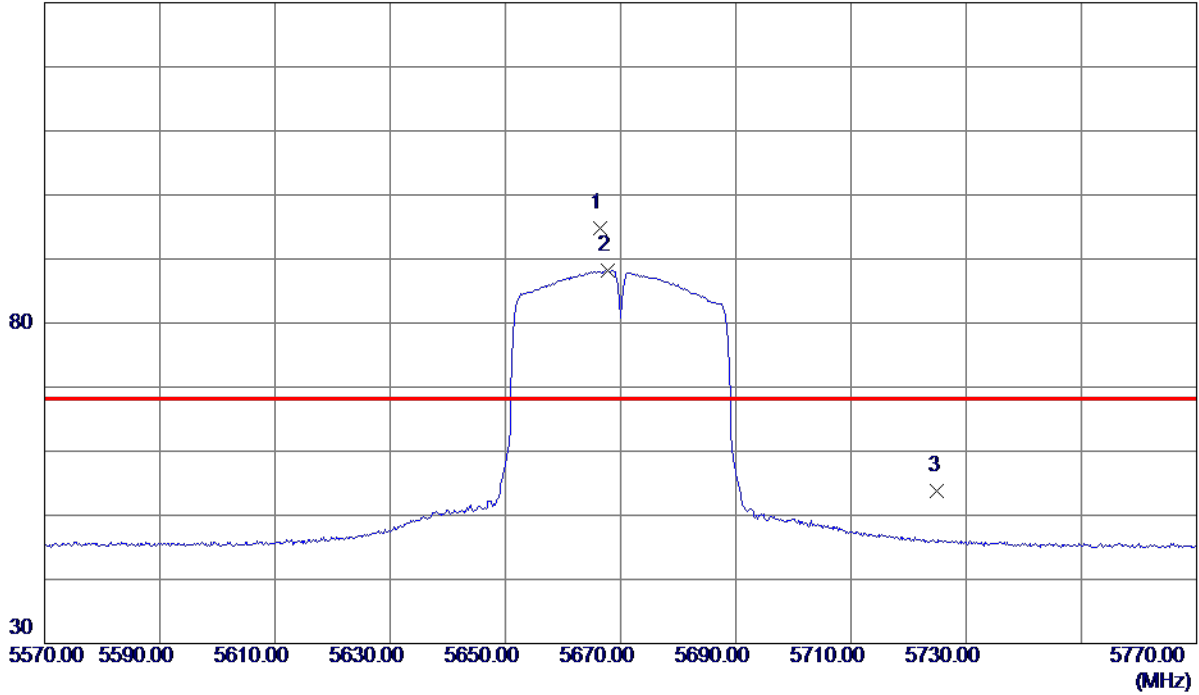

No.	Freq. MHz	Reading Level dBuV/m	Correct Factor dB	Measure ment dBuV/m	Limit dBuV/m	Margin dB	Detector	Comment
1 *	5666.4000	79.11	15.76	94.87	68.30	26.57	Peak	No Limit
2	5667.8000	72.46	15.76	88.22	999.00	-910.78	AVG	No Limit
3	5725.0000	37.97	15.88	53.85	68.30	-14.45	Peak	

**REMARKS:**

- (1) Measurement Value = Reading Level + Correct Factor.
- (2) Margin Level = Measurement Value - Limit Value.

Orthogonal Axis	X
Test Mode	UNII-2C_TX N (HT40) Mode 5670 MHz

### Horizontal

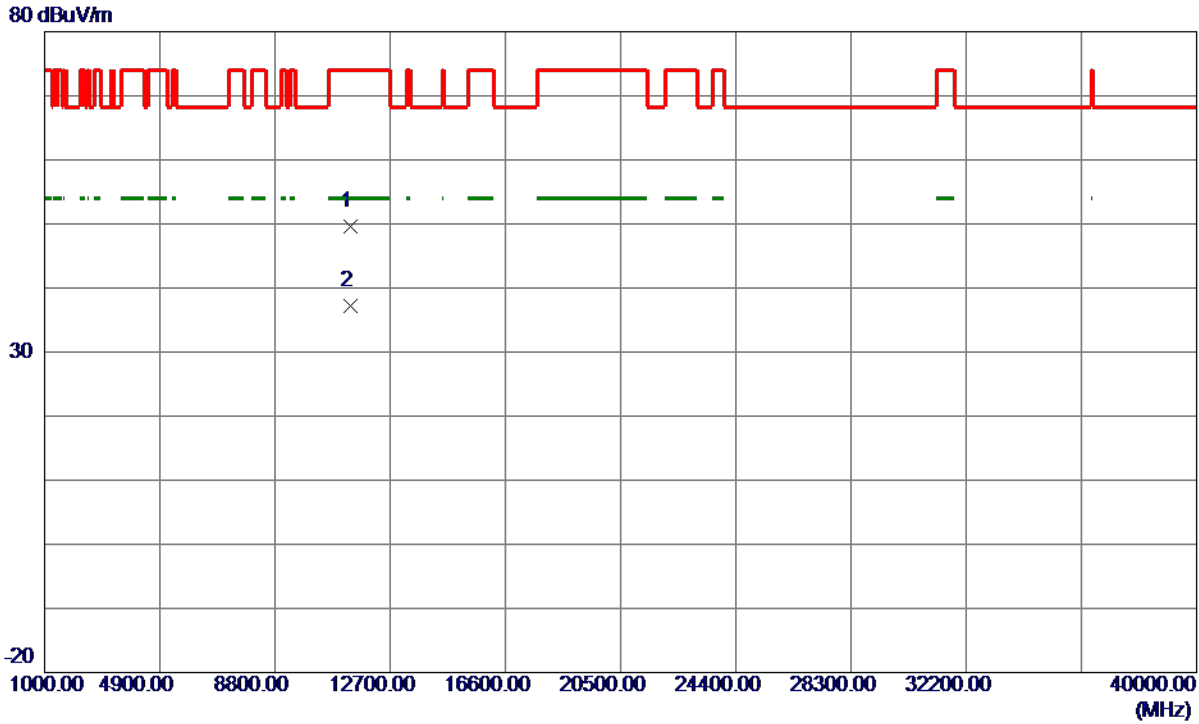

No.	Freq. MHz	Reading Level dBuV/m	Correct Factor dB	Measure ment dBuV/m	Limit dBuV/m	Margin dB	Detector	Comment
1	11340.0000	35.68	13.90	49.58	74.00	-24.42	Peak	
2 *	11340.0000	23.32	13.90	37.22	54.00	-16.78	AVG	

**REMARKS:**

- (1) Measurement Value = Reading Level + Correct Factor.
- (2) Margin Level = Measurement Value - Limit Value.



Orthogonal Axis	X
Test Mode	UNII-3_TX A Mode 5745 MHz

### Vertical

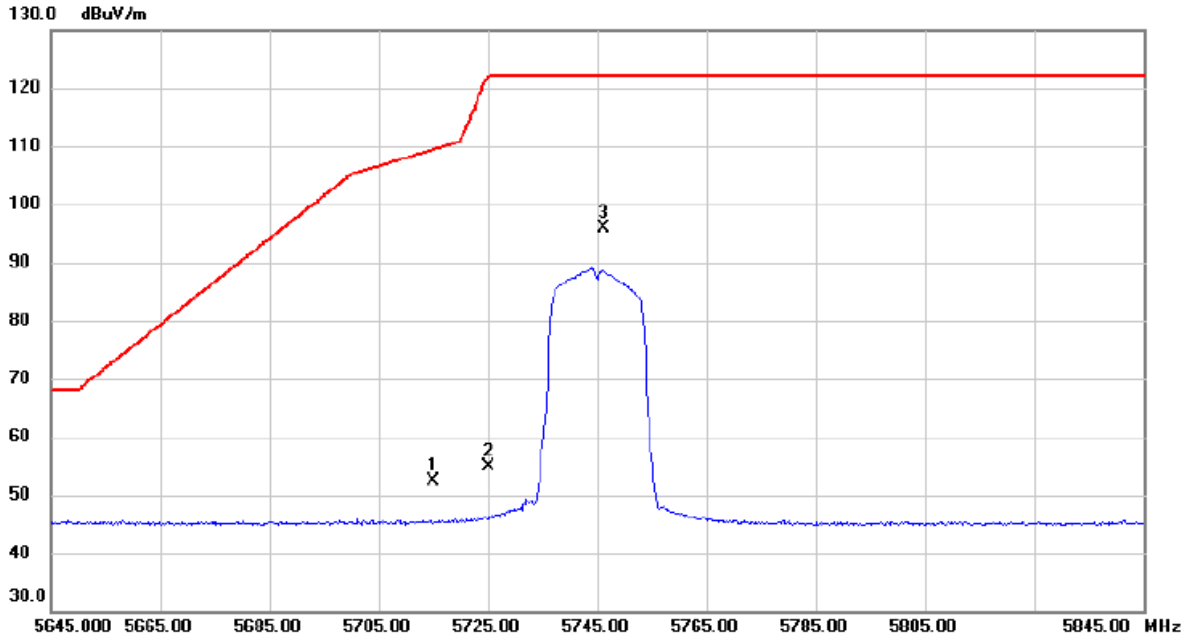

No.	Mk.	Freq.	Reading Level	Correct Factor	Measurement	Limit	Margin	Detector	Comment
		MHz	dBuV	dB	dBuV/m	dBuV/m	dB		
1		5715.000	36.64	15.86	52.50	109.40	-56.90	peak	
2		5725.000	39.08	15.88	54.96	122.20	-67.24	peak	
3	*	5746.200	80.01	15.92	95.93	122.20	-26.27	peak	No Limit

**REMARKS:**

- (1) Measurement Value = Reading Level + Correct Factor.
- (2) Margin Level = Measurement Value - Limit Value.

Orthogonal Axis	X
Test Mode	UNII-3_TX A Mode 5745 MHz

**Vertical**

80 dBuV/m

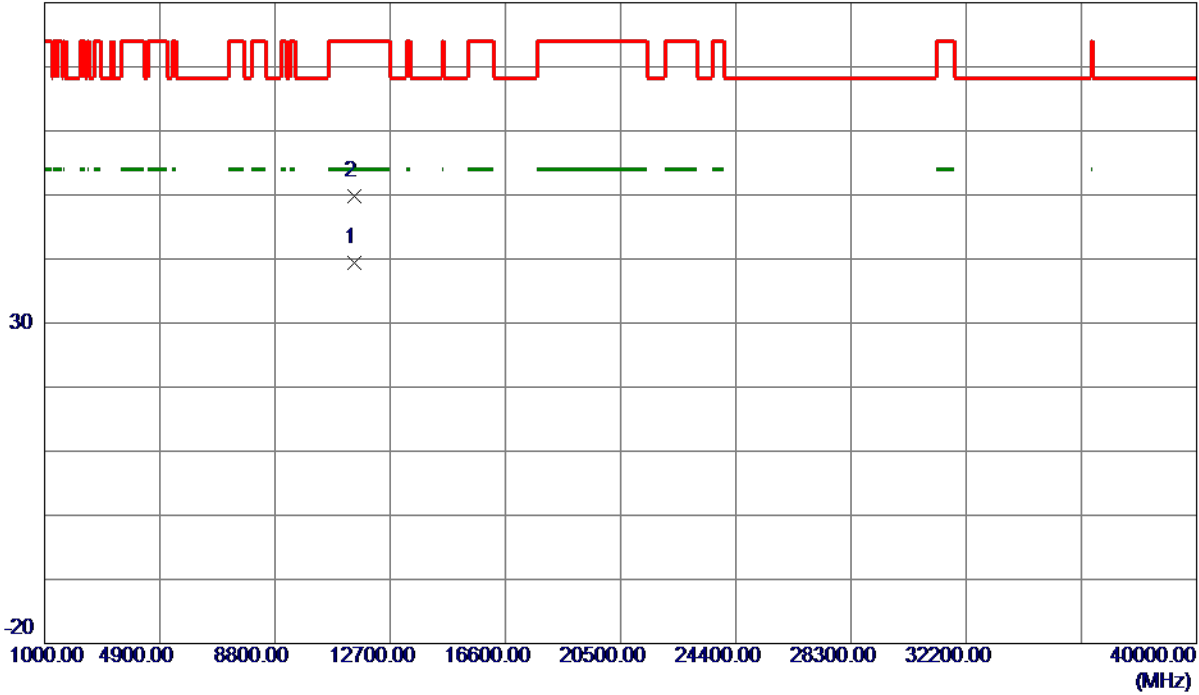

No.	Freq. MHz	Reading Level dBuV/m	Correct Factor dB	Measure ment dBuV/m	Limit dBuV/m	Margin dB	Detector	Comment
1 *	11496.2400	26.71	12.76	39.47	54.00	-14.53	AVG	
2	11497.4800	37.05	12.76	49.81	74.00	-24.19	Peak	

**REMARKS:**

- (1) Measurement Value = Reading Level + Correct Factor.
- (2) Margin Level = Measurement Value - Limit Value.

Orthogonal Axis	X
Test Mode	UNII-3_TX A Mode 5745 MHz

### Horizontal

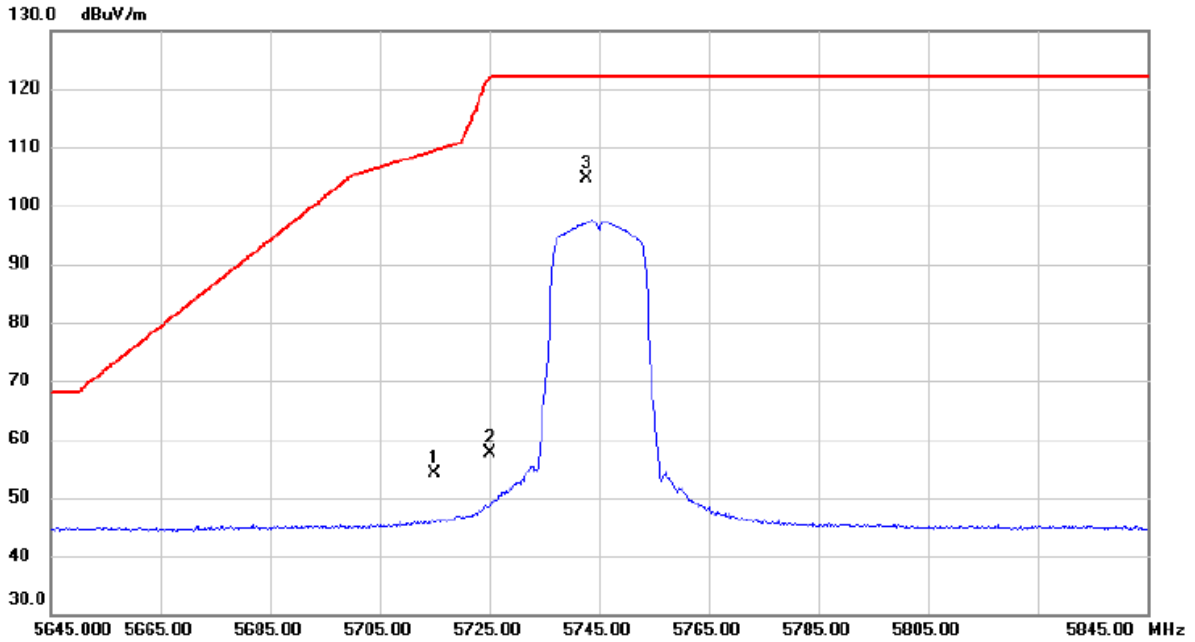

No.	Mk.	Freq. MHz	Reading Level dBuV	Correct Factor dB	Measure- ment dBuV/m	Limit dBuV/m	Margin dB	Detector	Comment
1		5715.000	38.38	15.86	54.24	109.40	-55.16	peak	
2		5725.000	41.63	15.88	57.51	122.20	-64.69	peak	
3	*	5742.800	88.68	15.92	104.60	122.20	-17.60	peak	No Limit

**REMARKS:**

- (1) Measurement Value = Reading Level + Correct Factor.
- (2) Margin Level = Measurement Value - Limit Value.

Orthogonal Axis	X
Test Mode	UNII-3_TX A Mode 5745 MHz

### Horizontal

80 dBuV/m

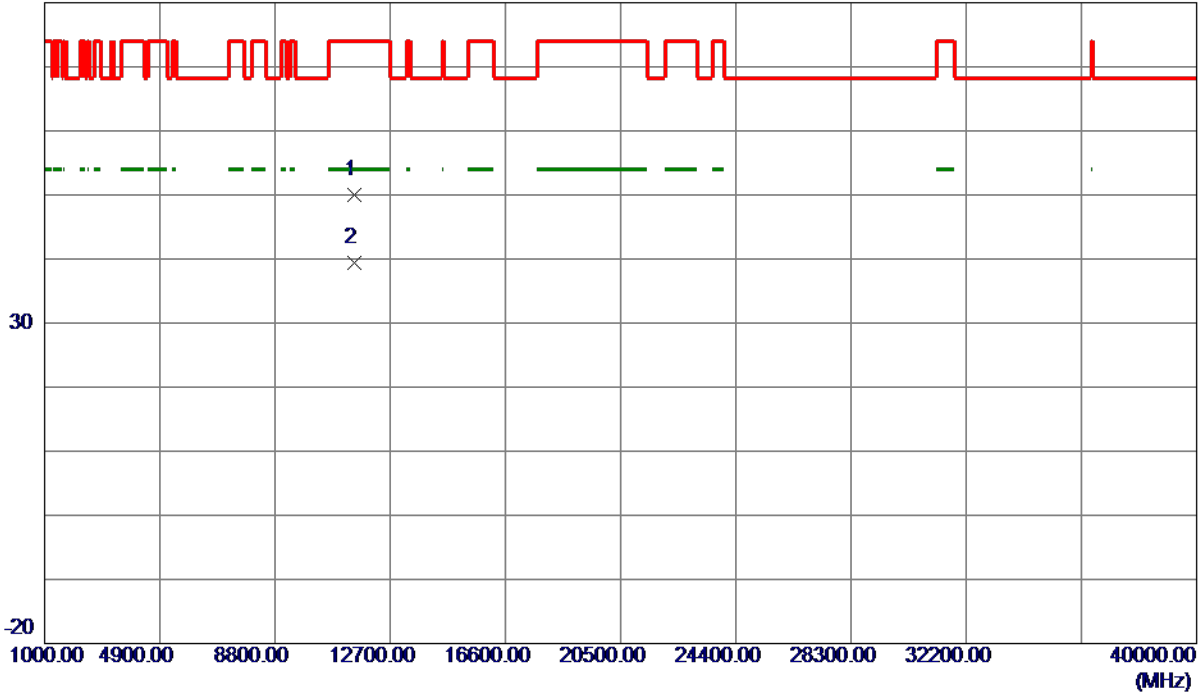

No.	Freq. MHz	Reading Level dBuV/m	Correct Factor dB	Measure ment dBuV/m	Limit dBuV/m	Margin dB	Detector	Comment
1	11483.7800	37.18	12.74	49.92	74.00	-24.08	Peak	
2 *	11485.5800	26.70	12.74	39.44	54.00	-14.56	AVG	

**REMARKS:**

- (1) Measurement Value = Reading Level + Correct Factor.
- (2) Margin Level = Measurement Value - Limit Value.

Orthogonal Axis	X
Test Mode	UNII-3_TX A Mode 5785 MHz

### Vertical

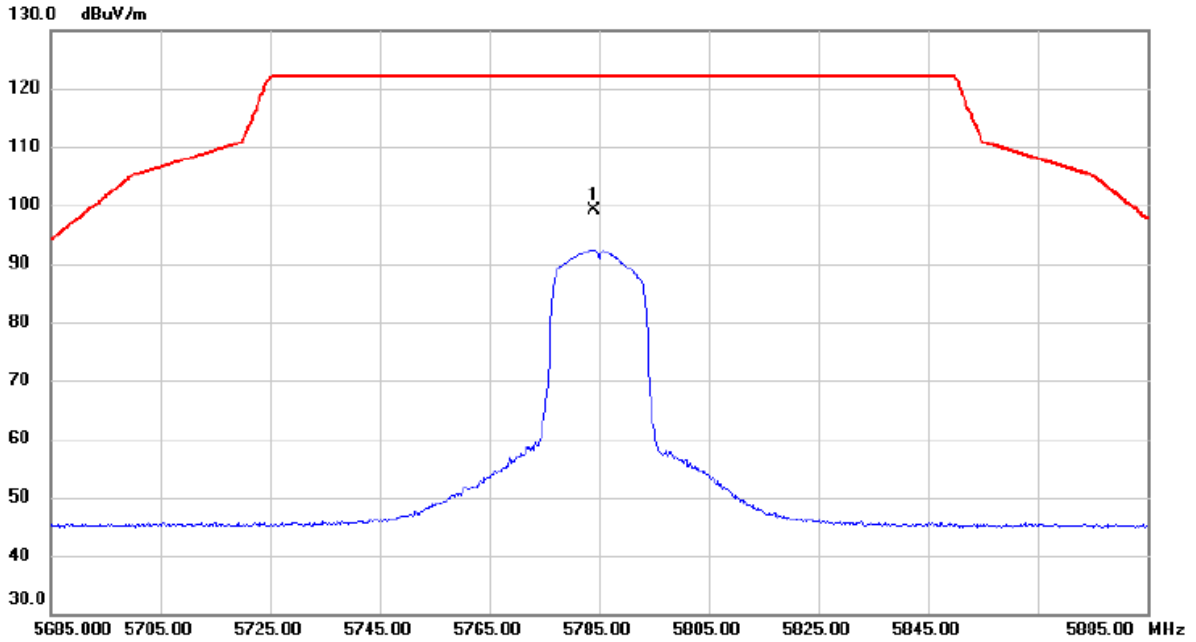

No.	Mk.	Freq.	Reading Level	Correct Factor	Measurement	Limit	Margin	Detector	Comment
		MHz	dBuV	dB	dBuV/m	dBuV/m	dB		
1	*	5784.200	83.10	16.01	99.11	122.20	-23.09	peak	No Limit

**REMARKS:**

- (1) Measurement Value = Reading Level + Correct Factor.
- (2) Margin Level = Measurement Value - Limit Value.

Orthogonal Axis	X
Test Mode	UNII-3_TX A Mode 5785 MHz

**Vertical**

80 dBuV/m

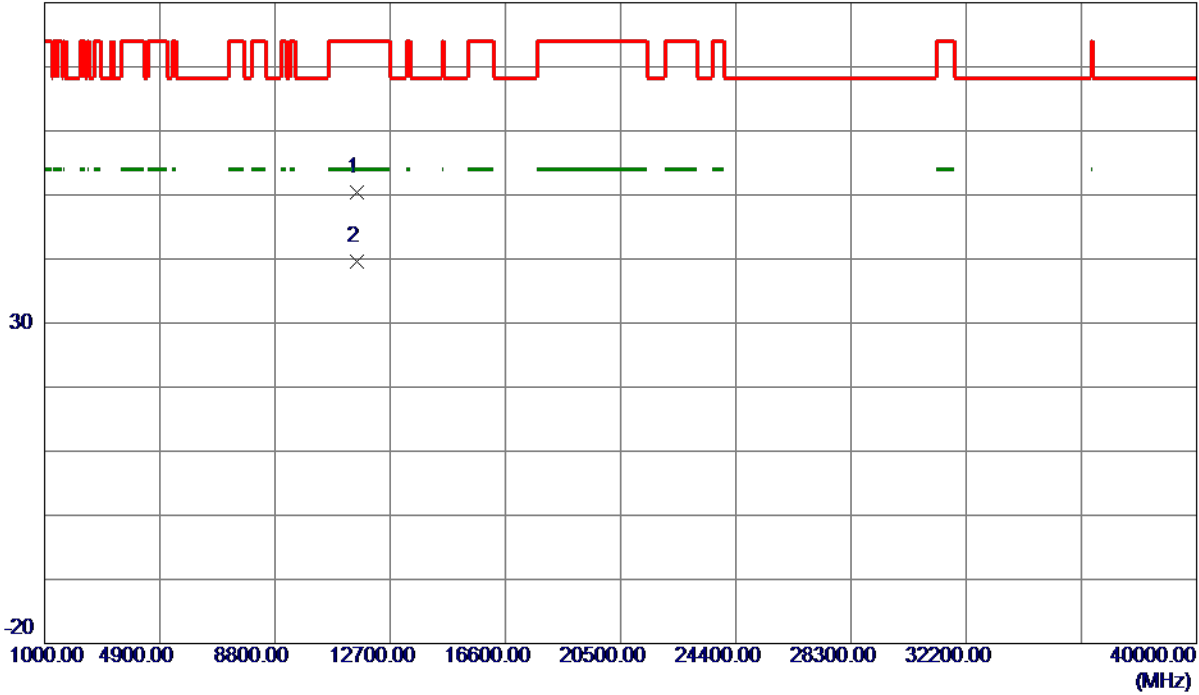

No.	Freq. MHz	Reading Level dBuV/m	Correct Factor dB	Measure ment dBuV/m	Limit dBuV/m	Margin dB	Detector	Comment
1	11562.7800	37.65	12.82	50.47	74.00	-23.53	Peak	
2 *	11572.4400	26.77	12.83	39.60	54.00	-14.40	AVG	

**REMARKS:**

- (1) Measurement Value = Reading Level + Correct Factor.
- (2) Margin Level = Measurement Value - Limit Value.

Orthogonal Axis	X
Test Mode	UNII-3_TX A Mode 5785 MHz

### Horizontal

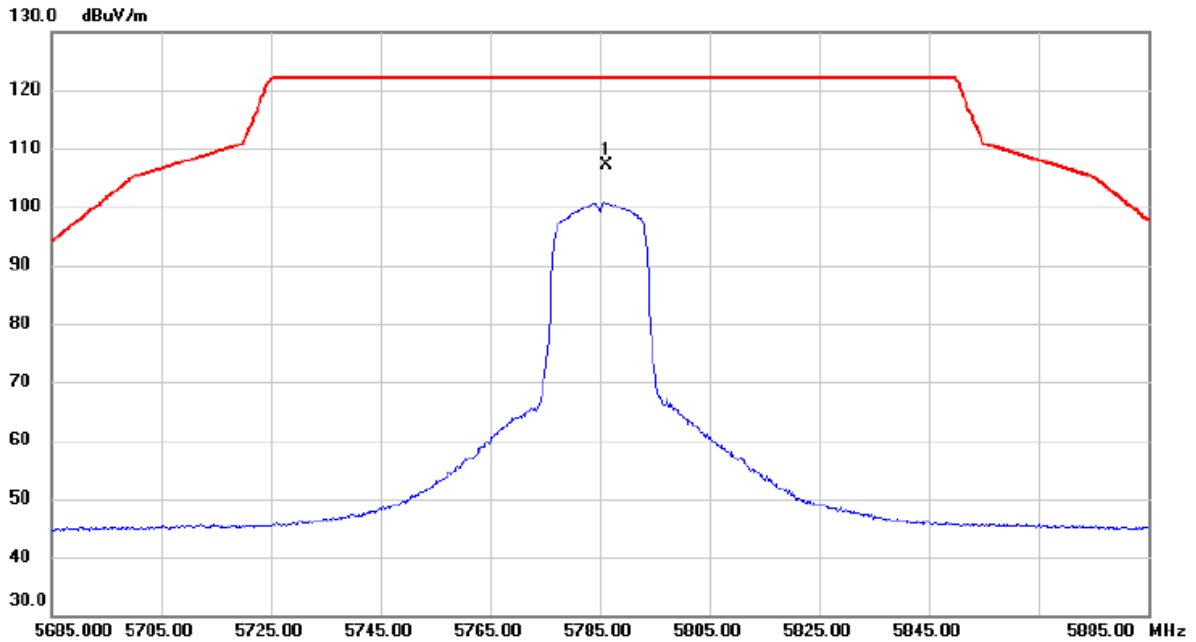

No.	Mk.	Freq.	Reading Level	Correct Factor	Measurement	Limit	Margin	Detector	Comment
		MHz	dBuV	dB	dBuV/m	dBuV/m	dB		
1	*	5786.200	91.13	16.01	107.14	122.20	-15.06	peak	No Limit

**REMARKS:**

- (1) Measurement Value = Reading Level + Correct Factor.
- (2) Margin Level = Measurement Value - Limit Value.

Orthogonal Axis	X
Test Mode	UNII-3_TX A Mode 5785 MHz

### Horizontal

80 dBuV/m

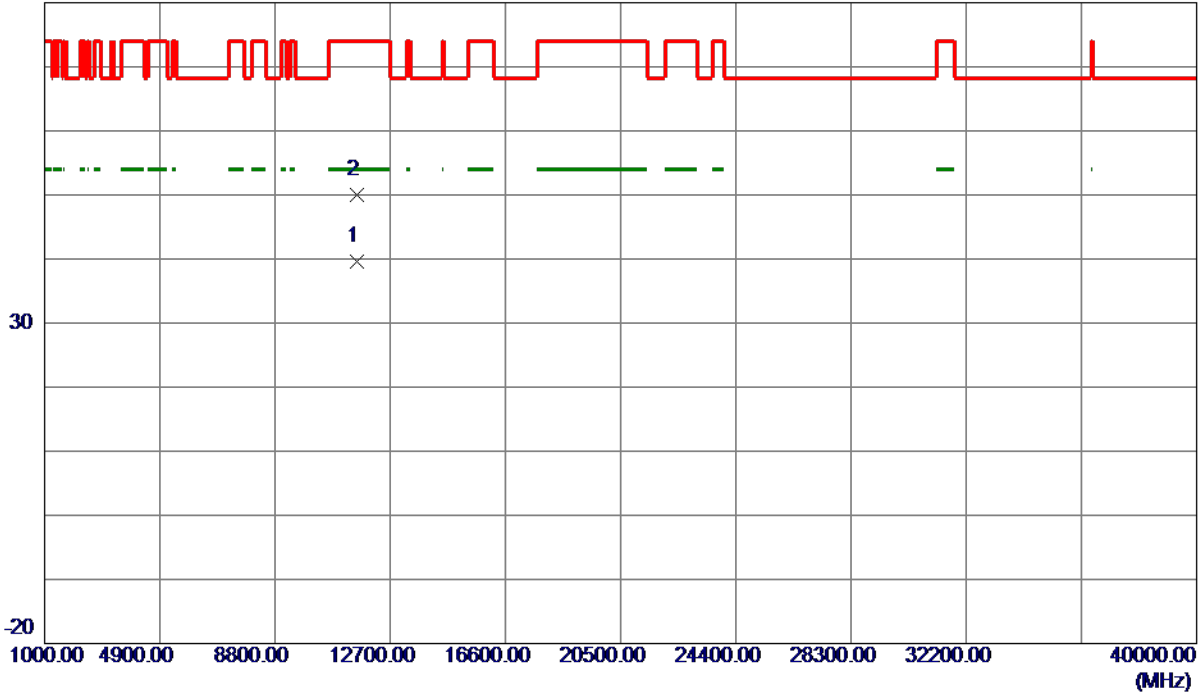

No.	Freq. MHz	Reading Level dBuV/m	Correct Factor dB	Measure ment dBuV/m	Limit dBuV/m	Margin dB	Detector	Comment
1 *	11566.8200	26.70	12.82	39.52	54.00	-14.48	AVG	
2	11575.1000	37.21	12.83	50.04	74.00	-23.96	Peak	

**REMARKS:**

- (1) Measurement Value = Reading Level + Correct Factor.
- (2) Margin Level = Measurement Value - Limit Value.



Orthogonal Axis	X
Test Mode	UNII-3_TX A Mode 5825 MHz

### Vertical

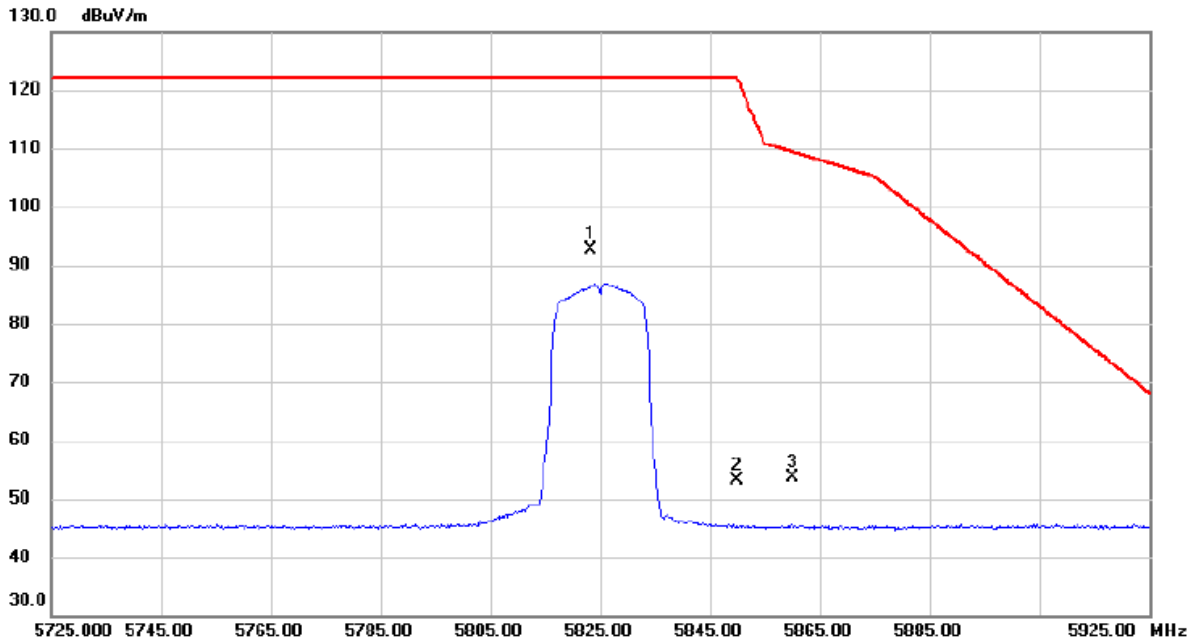

No.	Mk.	Freq. MHz	Reading Level dBuV	Correct Factor dB	Measure- ment dBuV/m	Limit dBuV/m	Margin dB	Detector	Comment
1	*	5823.200	76.65	16.10	92.75	122.20	-29.45	peak	No Limit
2		5850.000	37.07	16.16	53.23	122.20	-68.97	peak	
3		5860.000	37.56	16.18	53.74	109.40	-55.66	peak	

**REMARKS:**

- (1) Measurement Value = Reading Level + Correct Factor.
- (2) Margin Level = Measurement Value - Limit Value.

Orthogonal Axis	X
Test Mode	UNII-3_TX A Mode 5825 MHz

**Vertical**

80 dBuV/m

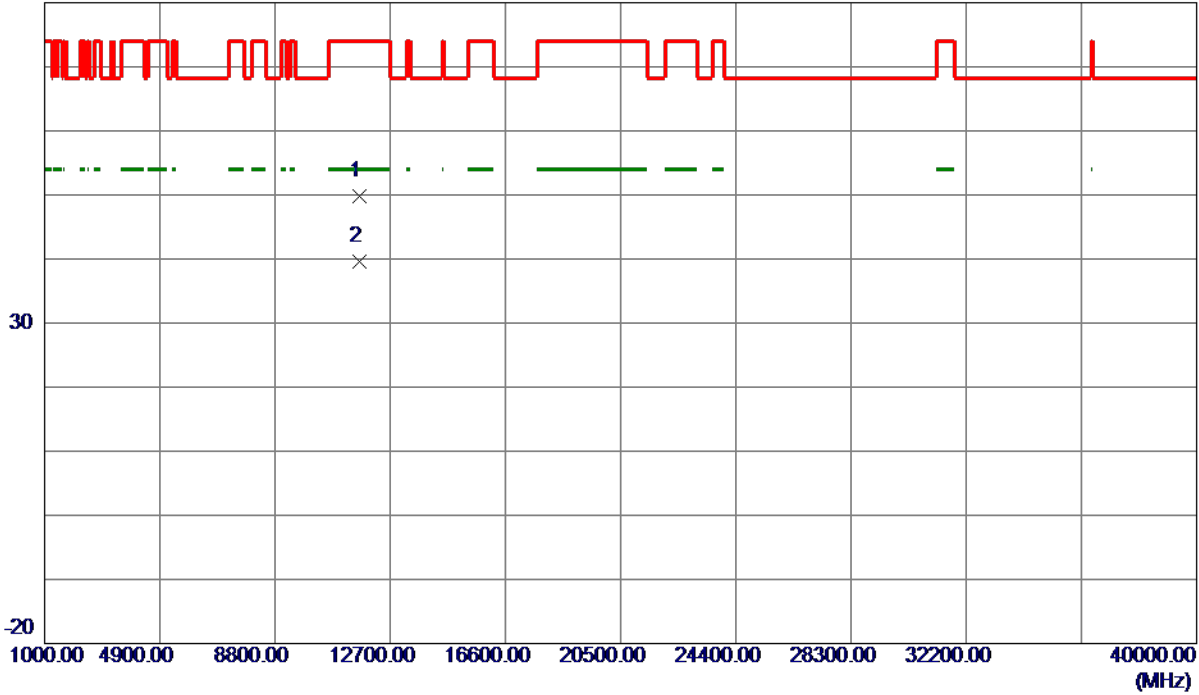

No.	Freq. MHz	Reading Level dBuV/m	Correct Factor dB	Measure ment dBuV/m	Limit dBuV/m	Margin dB	Detector	Comment
1	11645.2200	36.98	12.89	49.87	74.00	-24.13	Peak	
2 *	11657.5000	26.67	12.90	39.57	54.00	-14.43	AVG	

**REMARKS:**

- (1) Measurement Value = Reading Level + Correct Factor.
- (2) Margin Level = Measurement Value - Limit Value.

Orthogonal Axis	X
Test Mode	UNII-3_TX A Mode 5825 MHz

### Horizontal

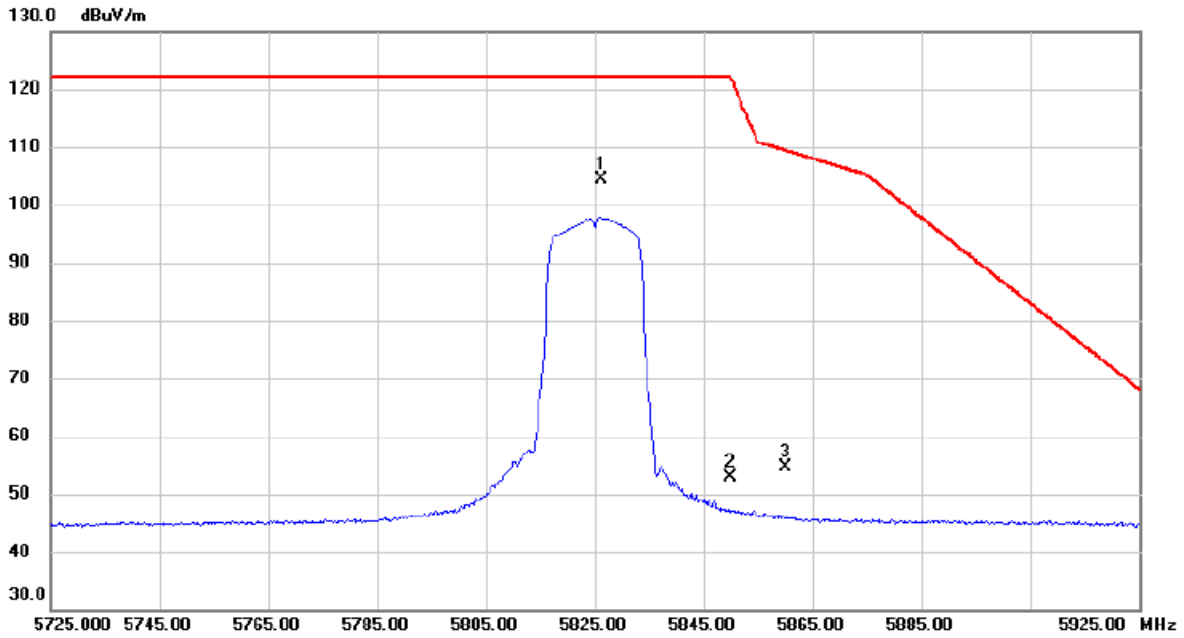

No.	Mk.	Freq. MHz	Reading Level dBuV	Correct Factor dB	Measure- ment dBuV/m	Limit dBuV/m	Margin dB	Detector	Comment
1	*	5826.200	88.22	16.10	104.32	122.20	-17.88	peak	No Limit
2		5850.000	36.77	16.16	52.93	122.20	-69.27	peak	
3		5860.000	38.36	16.18	54.54	109.40	-54.86	peak	

**REMARKS:**

- (1) Measurement Value = Reading Level + Correct Factor.
- (2) Margin Level = Measurement Value - Limit Value.

Orthogonal Axis	X
Test Mode	UNII-3_TX A Mode 5825 MHz

### Horizontal

80 dBuV/m

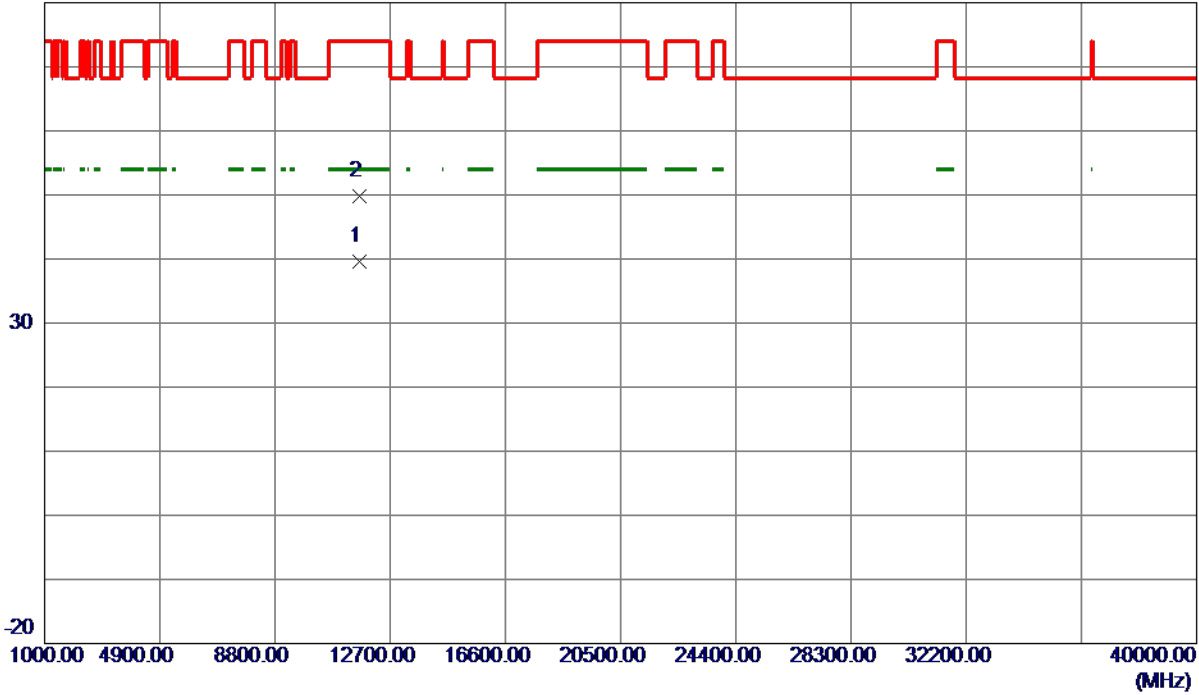

No.	Freq. MHz	Reading Level dBuV/m	Correct Factor dB	Measure ment dBuV/m	Limit dBuV/m	Margin dB	Detector	Comment
1 *	11654.6200	26.66	12.90	39.56	54.00	-14.44	AVG	
2	11656.6800	36.95	12.90	49.85	74.00	-24.15	Peak	

**REMARKS:**

- (1) Measurement Value = Reading Level + Correct Factor.
- (2) Margin Level = Measurement Value - Limit Value.

Orthogonal Axis	X
Test Mode	UNII-3_TX N (HT20) Mode 5745 MHz

**Vertical**

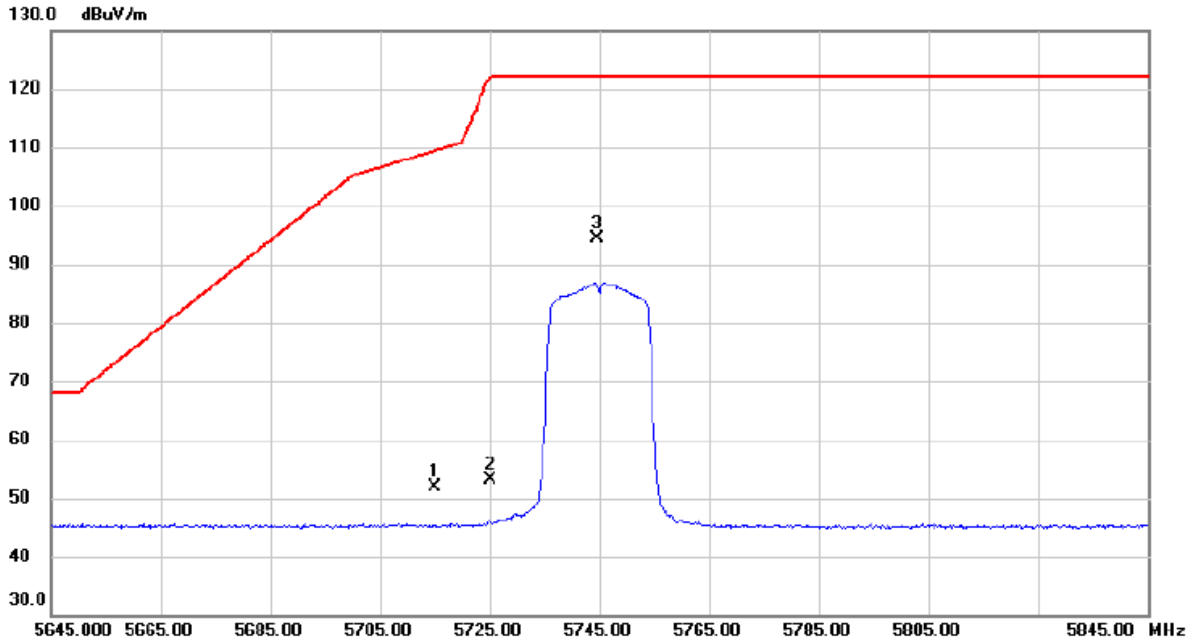

No.	Mk.	Freq. MHz	Reading Level dBuV	Correct Factor dB	Measure- ment dBuV/m	Limit dBuV/m	Margin dB	Detector	Comment
1		5715.000	35.90	15.86	51.76	109.40	-57.64	peak	
2		5725.000	37.23	15.88	53.11	122.20	-69.09	peak	
3	*	5744.600	78.46	15.92	94.38	122.20	-27.82	peak	No Limit

**REMARKS:**

- (1) Measurement Value = Reading Level + Correct Factor.
- (2) Margin Level = Measurement Value - Limit Value.

Orthogonal Axis	X
Test Mode	UNII-3_TX N (HT20) Mode 5745 MHz

**Vertical**

80 dBuV/m

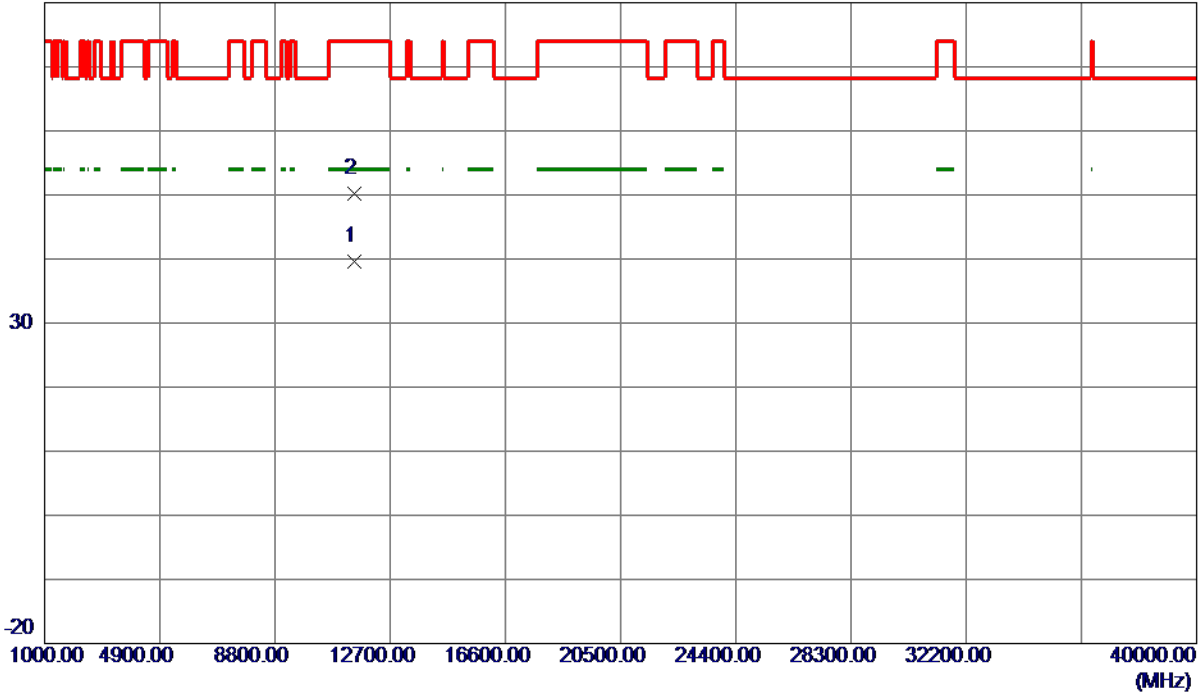

No.	Freq. MHz	Reading Level dBuV/m	Correct Factor dB	Measure ment dBuV/m	Limit dBuV/m	Margin dB	Detector	Comment
1 *	11492.6400	26.77	12.75	39.52	54.00	-14.48	AVG	
2	11495.3200	37.44	12.76	50.20	74.00	-23.80	Peak	

**REMARKS:**

- (1) Measurement Value = Reading Level + Correct Factor.
- (2) Margin Level = Measurement Value - Limit Value.

Orthogonal Axis	X
Test Mode	UNII-3_TX N (HT20) Mode 5745 MHz

### Horizontal

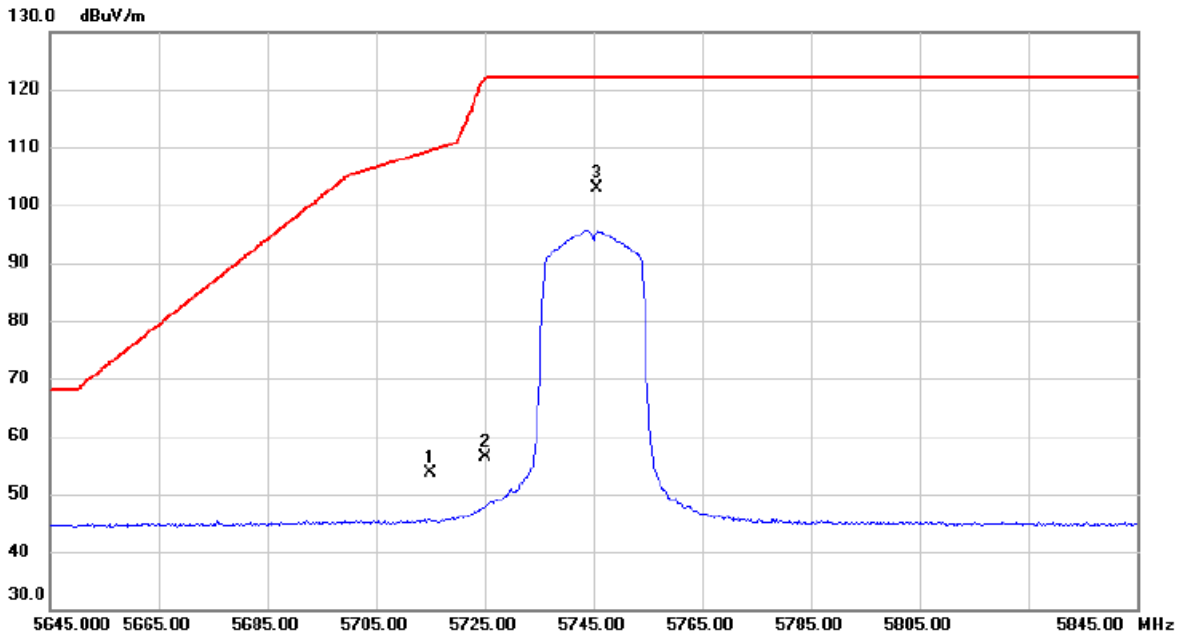

No.	Mk.	Freq. MHz	Reading Level dBuV	Correct Factor dB	Measure- ment dBuV/m	Limit dBuV/m	Margin dB	Detector	Comment
1		5715.000	37.66	15.86	53.52	109.40	-55.88	peak	
2		5725.000	40.47	15.88	56.35	122.20	-65.85	peak	
3	*	5745.600	87.06	15.92	102.98	122.20	-19.22	peak	No Limit

**REMARKS:**

- (1) Measurement Value = Reading Level + Correct Factor.
- (2) Margin Level = Measurement Value - Limit Value.

Orthogonal Axis	X
Test Mode	UNII-3_TX N (HT20) Mode 5745 MHz

### Horizontal

80 dBuV/m

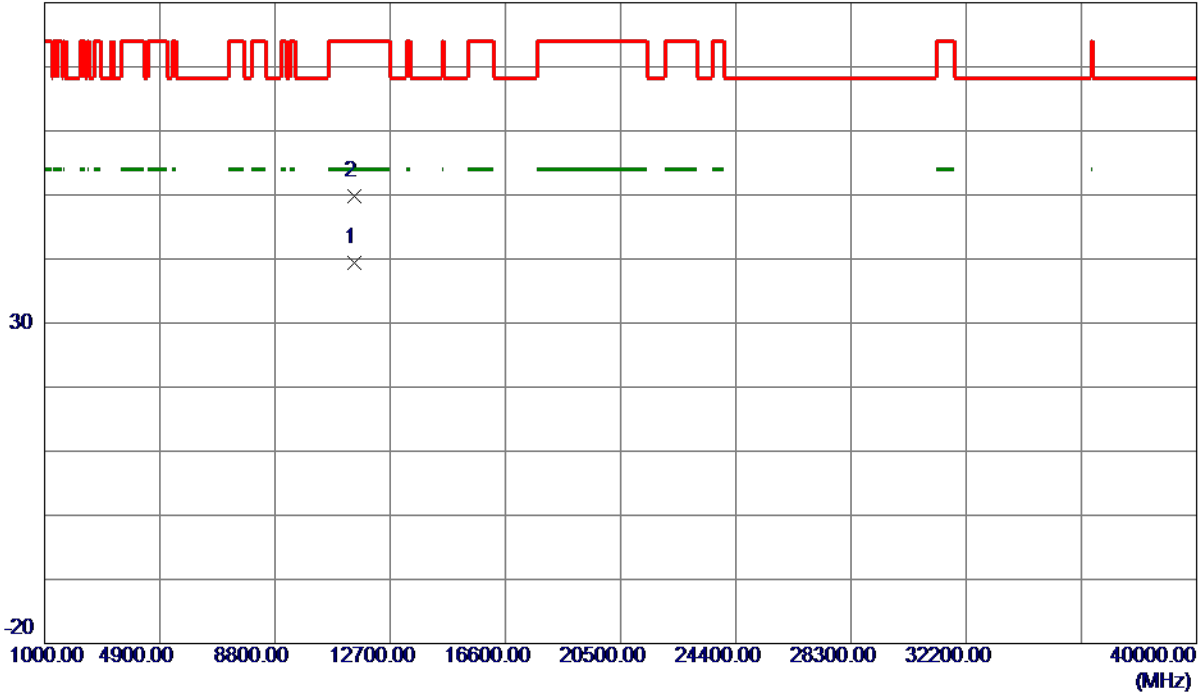

No.	Freq. MHz	Reading Level dBuV/m	Correct Factor dB	Measure ment dBuV/m	Limit dBuV/m	Margin dB	Detector	Comment
1 *	11491.1200	26.70	12.75	39.45	54.00	-14.55	AVG	
2	11491.8000	36.98	12.75	49.73	74.00	-24.27	Peak	

**REMARKS:**

- (1) Measurement Value = Reading Level + Correct Factor.
- (2) Margin Level = Measurement Value - Limit Value.



Orthogonal Axis	X
Test Mode	UNII-3_TX N (HT20) Mode 5785 MHz

### Vertical

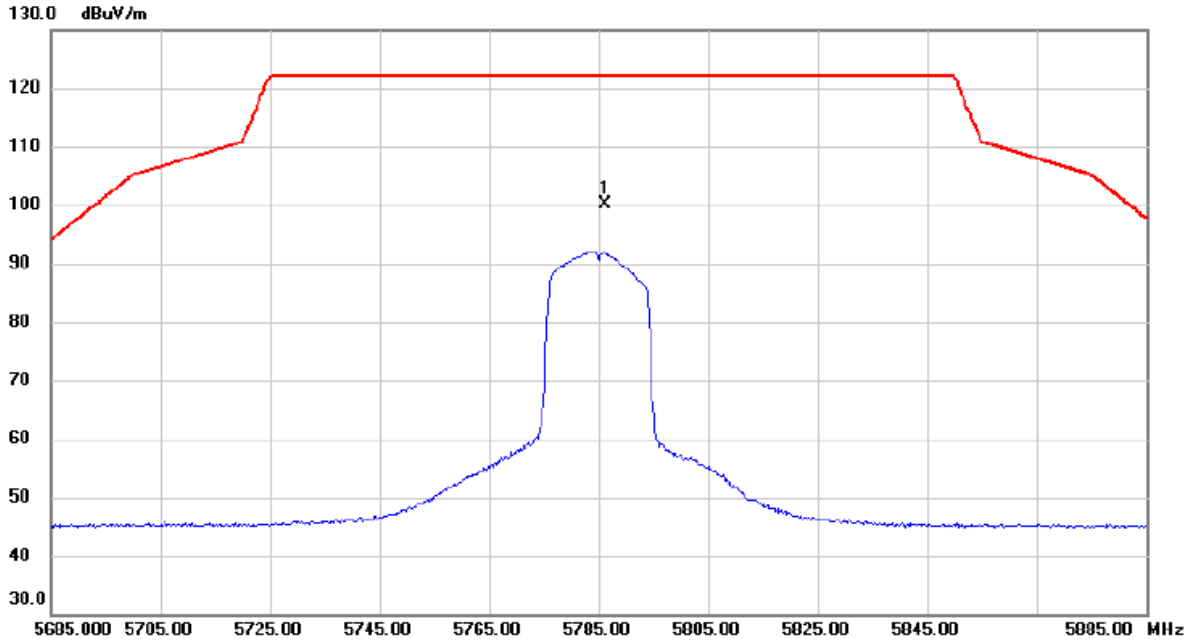

No.	Mk.	Freq. MHz	Reading Level dBuV	Correct Factor dB	Measure- ment dBuV/m	Limit dBuV/m	Margin dB	Detector	Comment
1	*	5786.200	84.06	16.01	100.07	122.20	-22.13	peak	No Limit

**REMARKS:**

- (1) Measurement Value = Reading Level + Correct Factor.
- (2) Margin Level = Measurement Value - Limit Value.

Orthogonal Axis	X
Test Mode	UNII-3_TX N (HT20) Mode 5785 MHz

**Vertical**

80 dBuV/m

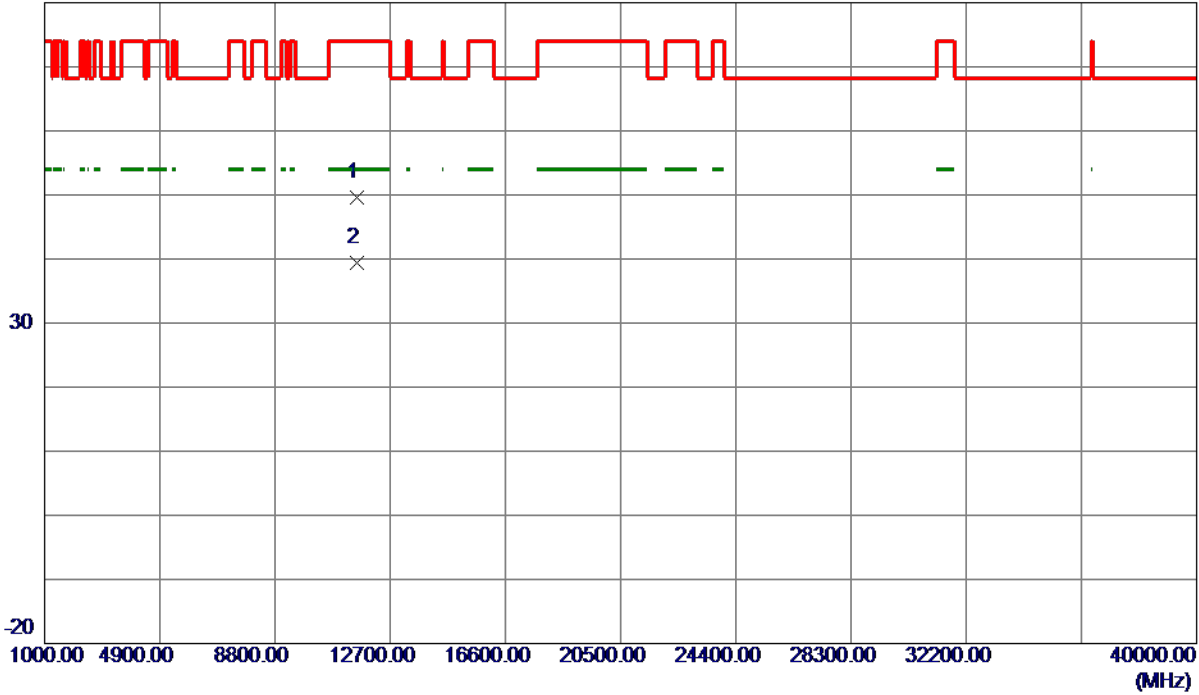

No.	Freq. MHz	Reading Level dBuV/m	Correct Factor dB	Measure ment dBuV/m	Limit dBuV/m	Margin dB	Detector	Comment
1	11562.9200	36.85	12.82	49.67	74.00	-24.33	Peak	
2 *	11574.8800	26.63	12.83	39.46	54.00	-14.54	AVG	

**REMARKS:**

- (1) Measurement Value = Reading Level + Correct Factor.
- (2) Margin Level = Measurement Value - Limit Value.

Orthogonal Axis	X
Test Mode	UNII-3_TX N (HT20) Mode 5785 MHz

### Horizontal

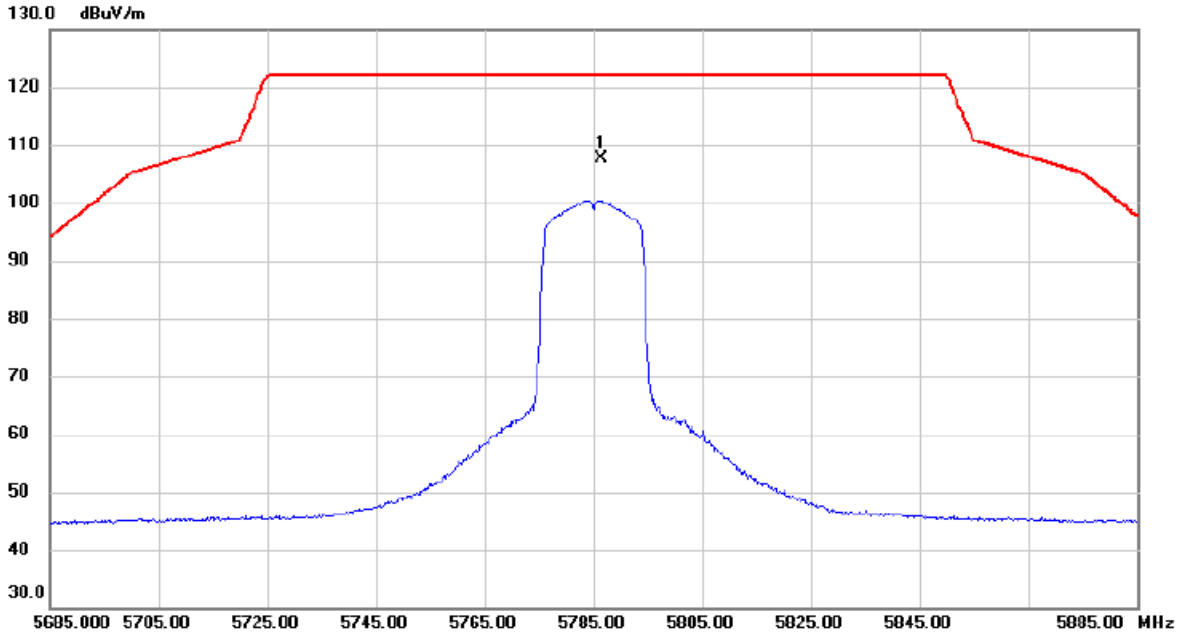

No.	Mk.	Freq.	Reading Level	Correct Factor	Measurement	Limit	Margin	Detector	Comment
		MHz	dBuV	dB	dBuV/m	dBuV/m	dB		
1	*	5786.400	91.54	16.01	107.55	122.20	-14.65	peak	No Limit

**REMARKS:**

- (1) Measurement Value = Reading Level + Correct Factor.
- (2) Margin Level = Measurement Value - Limit Value.

Orthogonal Axis	X
Test Mode	UNII-3_TX N (HT20) Mode 5785 MHz

### Horizontal

80 dBuV/m

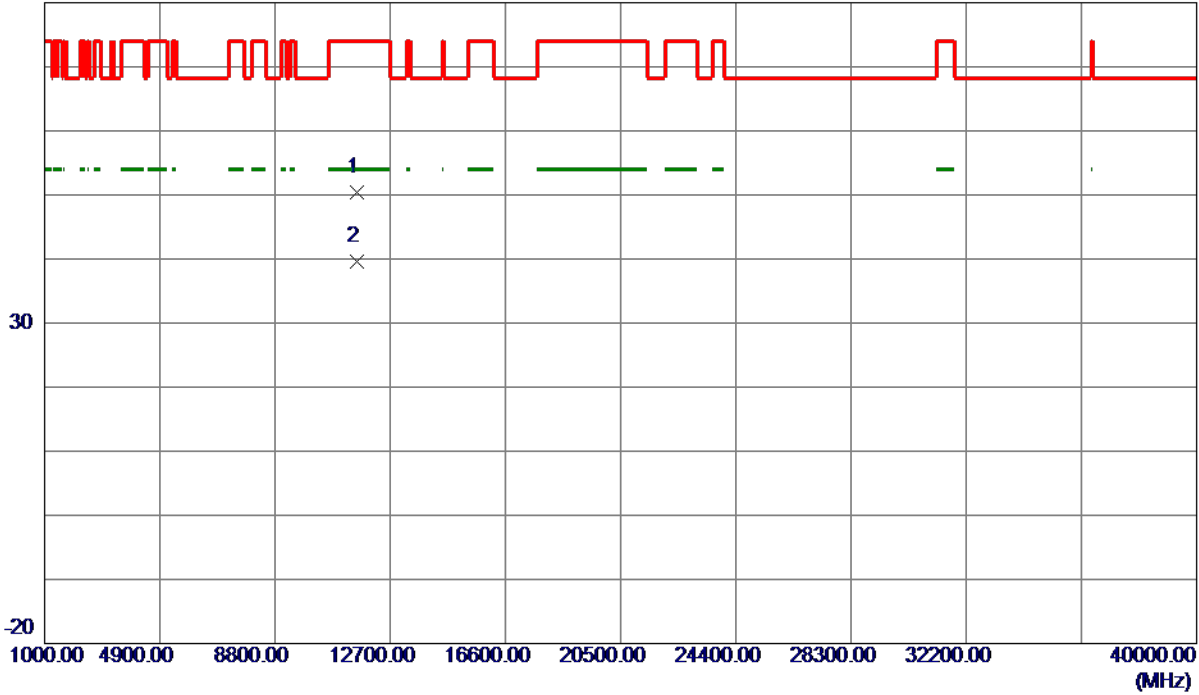

No.	Freq. MHz	Reading Level dBuV/m	Correct Factor dB	Measure ment dBuV/m	Limit dBuV/m	Margin dB	Detector	Comment
1	11560.7400	37.58	12.82	50.40	74.00	-23.60	Peak	
2 *	11571.6200	26.81	12.83	39.64	54.00	-14.36	AVG	

**REMARKS:**

- (1) Measurement Value = Reading Level + Correct Factor.
- (2) Margin Level = Measurement Value - Limit Value.

Orthogonal Axis	X
Test Mode	UNII-3_TX N (HT20) Mode 5825 MHz

### Vertical

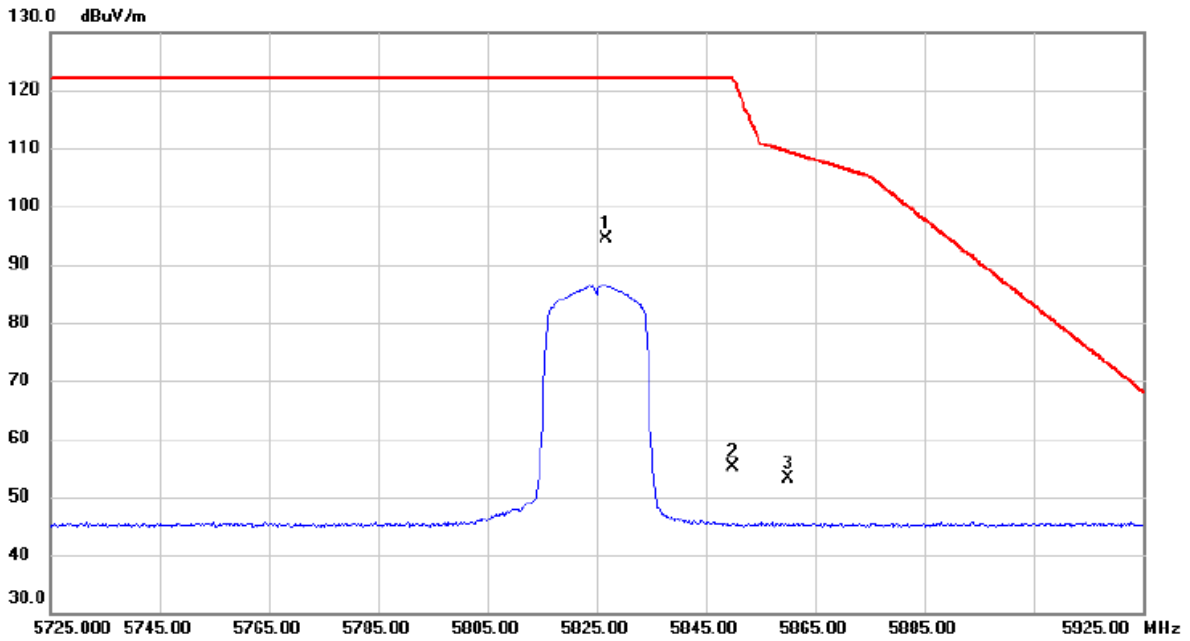

No.	Mk.	Freq. MHz	Reading Level dBuV	Correct Factor dB	Measure- ment dBuV/m	Limit dBuV/m	Margin dB	Detector	Comment
1	*	5826.800	78.23	16.10	94.33	122.20	-27.87	peak	No Limit
2		5850.000	38.91	16.16	55.07	122.20	-67.13	peak	
3		5860.000	37.06	16.18	53.24	109.40	-56.16	peak	

**REMARKS:**

- (1) Measurement Value = Reading Level + Correct Factor.
- (2) Margin Level = Measurement Value - Limit Value.

Orthogonal Axis	X
Test Mode	UNII-3_TX N (HT20) Mode 5825 MHz

**Vertical**

80 dBuV/m

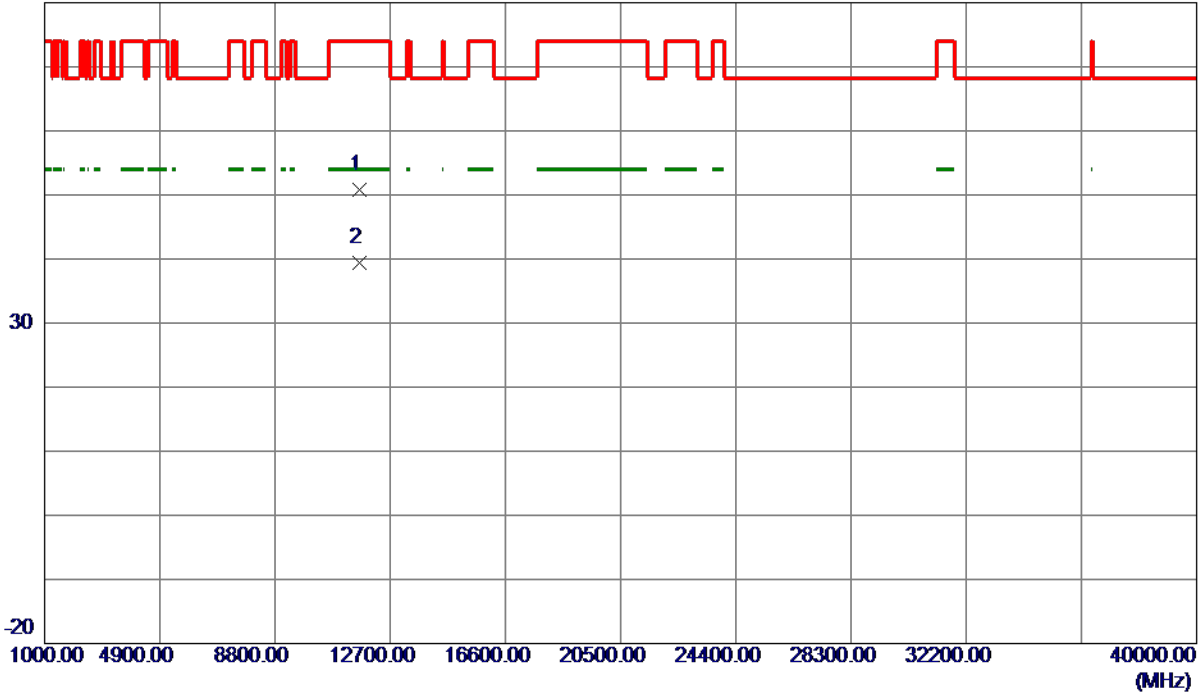

No.	Freq. MHz	Reading Level dBuV/m	Correct Factor dB	Measure ment dBuV/m	Limit dBuV/m	Margin dB	Detector	Comment
1	11644.5800	37.92	12.89	50.81	74.00	-23.19	Peak	
2 *	11648.2400	26.60	12.89	39.49	54.00	-14.51	AVG	

**REMARKS:**

- (1) Measurement Value = Reading Level + Correct Factor.
- (2) Margin Level = Measurement Value - Limit Value.

Orthogonal Axis	X
Test Mode	UNII-3_TX N (HT20) Mode 5825 MHz

### Horizontal

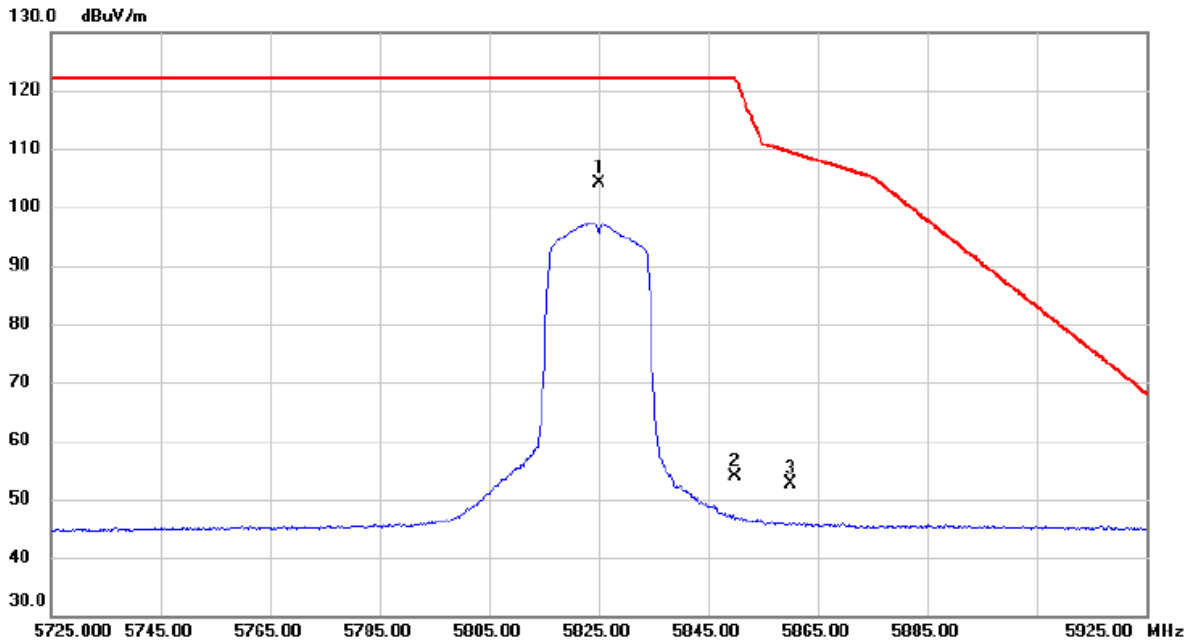

No.	Mk.	Freq. MHz	Reading Level dBuV	Correct Factor dB	Measure- ment dBuV/m	Limit dBuV/m	Margin dB	Detector	Comment
1	*	5825.200	87.97	16.10	104.07	122.20	-18.13	peak	No Limit
2		5850.000	37.73	16.16	53.89	122.20	-68.31	peak	
3		5860.000	36.56	16.18	52.74	109.40	-56.66	peak	

**REMARKS:**

- (1) Measurement Value = Reading Level + Correct Factor.
- (2) Margin Level = Measurement Value - Limit Value.

Orthogonal Axis	X
Test Mode	UNII-3_TX N (HT20) Mode 5825 MHz

### Horizontal

80 dBuV/m

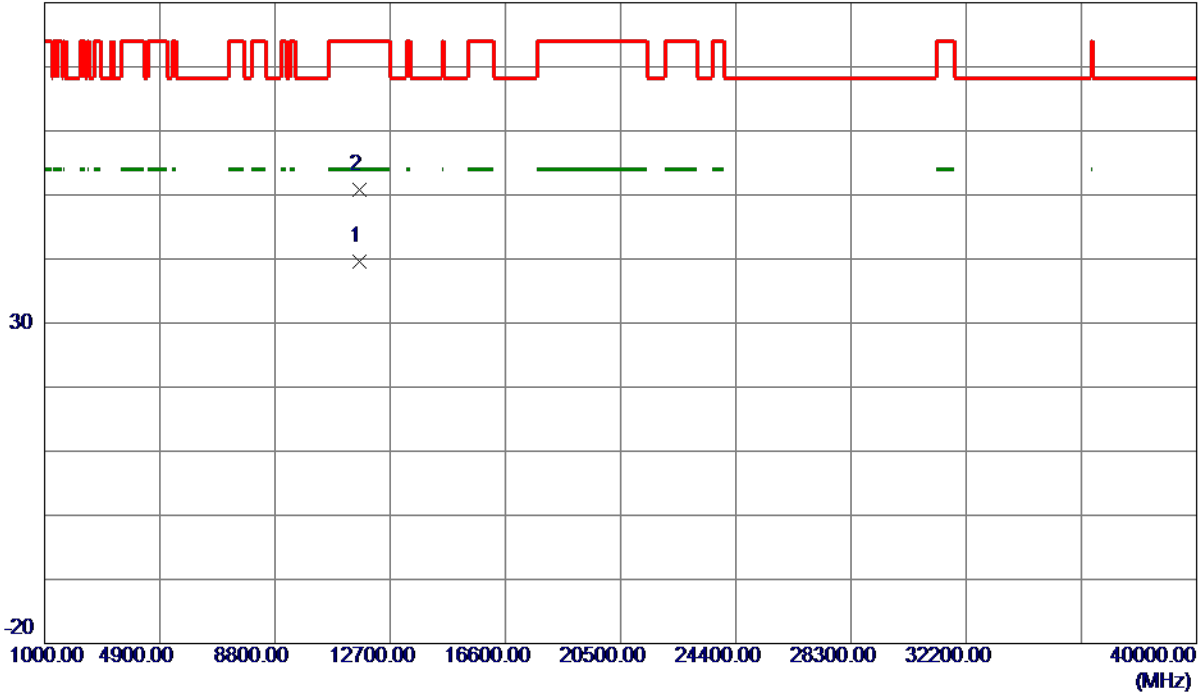

No.	Freq. MHz	Reading Level dBuV/m	Correct Factor dB	Measure ment dBuV/m	Limit dBuV/m	Margin dB	Detector	Comment
1 *	11640.2000	26.77	12.88	39.65	54.00	-14.35	AVG	
2	11643.8400	37.91	12.89	50.80	74.00	-23.20	Peak	

**REMARKS:**

- (1) Measurement Value = Reading Level + Correct Factor.
- (2) Margin Level = Measurement Value - Limit Value.



Orthogonal Axis	X
Test Mode	UNII-3_TX N (HT40) Mode 5755 MHz

**Vertical**

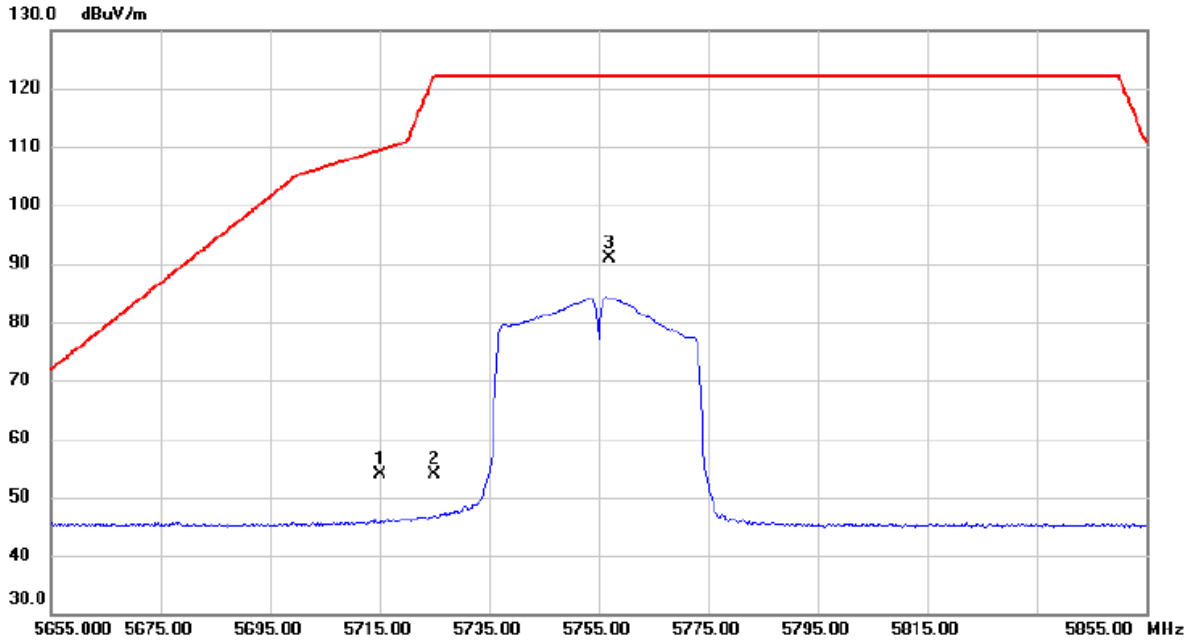

No.	Mk.	Freq. MHz	Reading Level dBuV	Correct Factor dB	Measure- ment dBuV/m	Limit dBuV/m	Margin dB	Detector	Comment
1		5715.000	37.91	15.86	53.77	109.40	-55.63	peak	
2		5725.000	38.00	15.88	53.88	122.20	-68.32	peak	
3	*	5757.000	75.03	15.95	90.98	122.20	-31.22	peak	No Limit

**REMARKS:**

- (1) Measurement Value = Reading Level + Correct Factor.
- (2) Margin Level = Measurement Value - Limit Value.

Orthogonal Axis	X
Test Mode	UNII-3_TX N (HT40) Mode 5755 MHz

### Vertical

80 dBuV/m

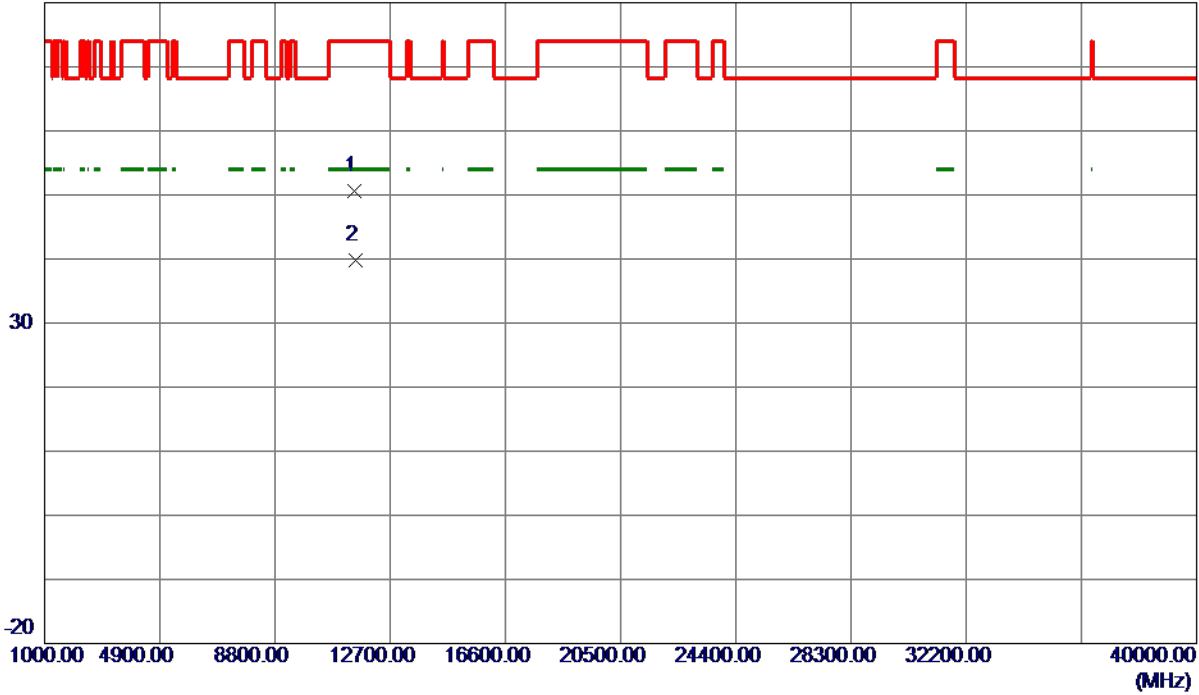

No.	Freq. MHz	Reading Level dBuV/m	Correct Factor dB	Measure ment dBuV/m	Limit dBuV/m	Margin dB	Detector	Comment
1	11501.2200	37.79	12.77	50.56	74.00	-23.44	Peak	
2 *	11512.4400	27.10	12.78	39.88	54.00	-14.12	AVG	

**REMARKS:**

- (1) Measurement Value = Reading Level + Correct Factor.
- (2) Margin Level = Measurement Value - Limit Value.

Orthogonal Axis	X
Test Mode	UNII-3_TX N (HT40) Mode 5755 MHz

### Horizontal

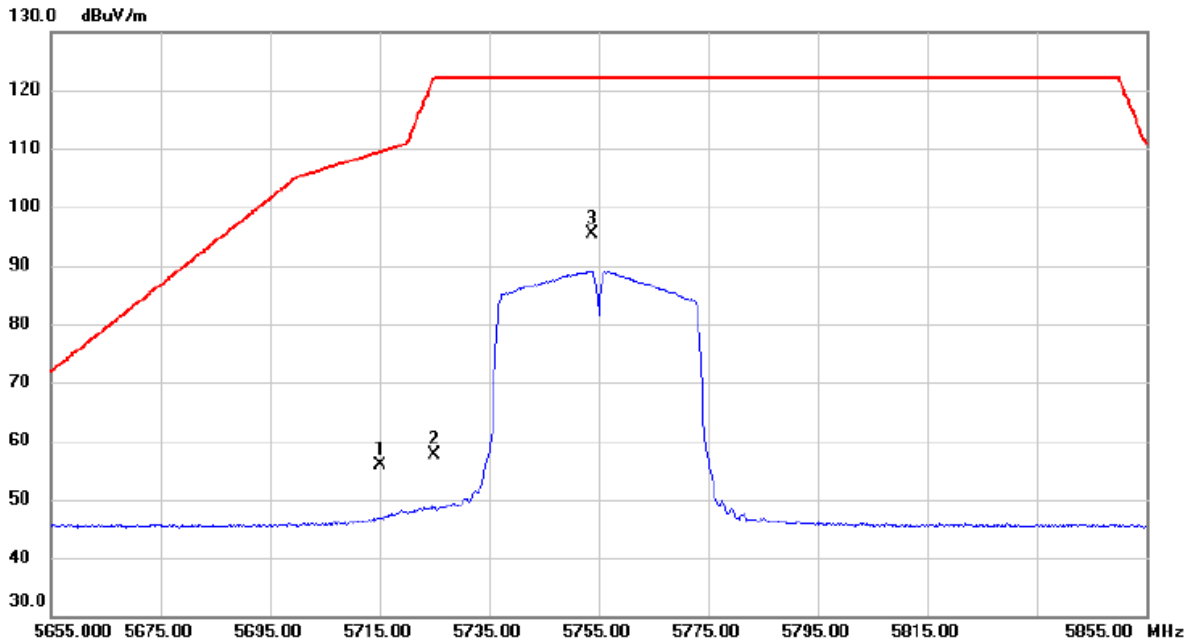

No.	Mk.	Freq. MHz	Reading Level dBuV	Correct Factor dB	Measure- ment dBuV/m	Limit dBuV/m	Margin dB	Detector	Comment
1		5715.000	40.13	15.86	55.99	109.40	-53.41	peak	
2		5725.000	41.81	15.88	57.69	122.20	-64.51	peak	
3	*	5753.800	79.52	15.95	95.47	122.20	-26.73	peak	No Limit

**REMARKS:**

- (1) Measurement Value = Reading Level + Correct Factor.
- (2) Margin Level = Measurement Value - Limit Value.

Orthogonal Axis	X
Test Mode	UNII-3_TX N (HT40) Mode 5755 MHz

### Horizontal

80 dBuV/m

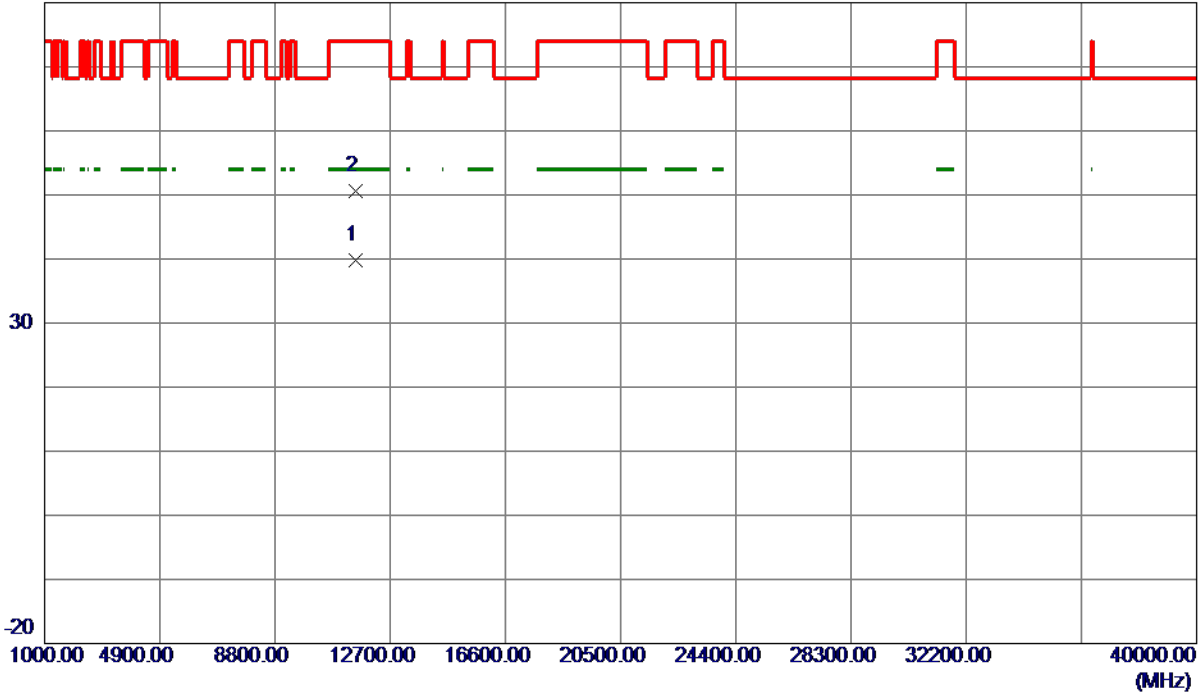

No.	Freq. MHz	Reading Level dBuV/m	Correct Factor dB	Measure ment dBuV/m	Limit dBuV/m	Margin dB	Detector	Comment
1 *	11511.9600	27.00	12.78	39.78	54.00	-14.22	AVG	
2	11515.7800	37.77	12.78	50.55	74.00	-23.45	Peak	

**REMARKS:**

- (1) Measurement Value = Reading Level + Correct Factor.
- (2) Margin Level = Measurement Value - Limit Value.

Orthogonal Axis	X
Test Mode	UNII-3_TX N (HT40) Mode 5795 MHz

### Vertical

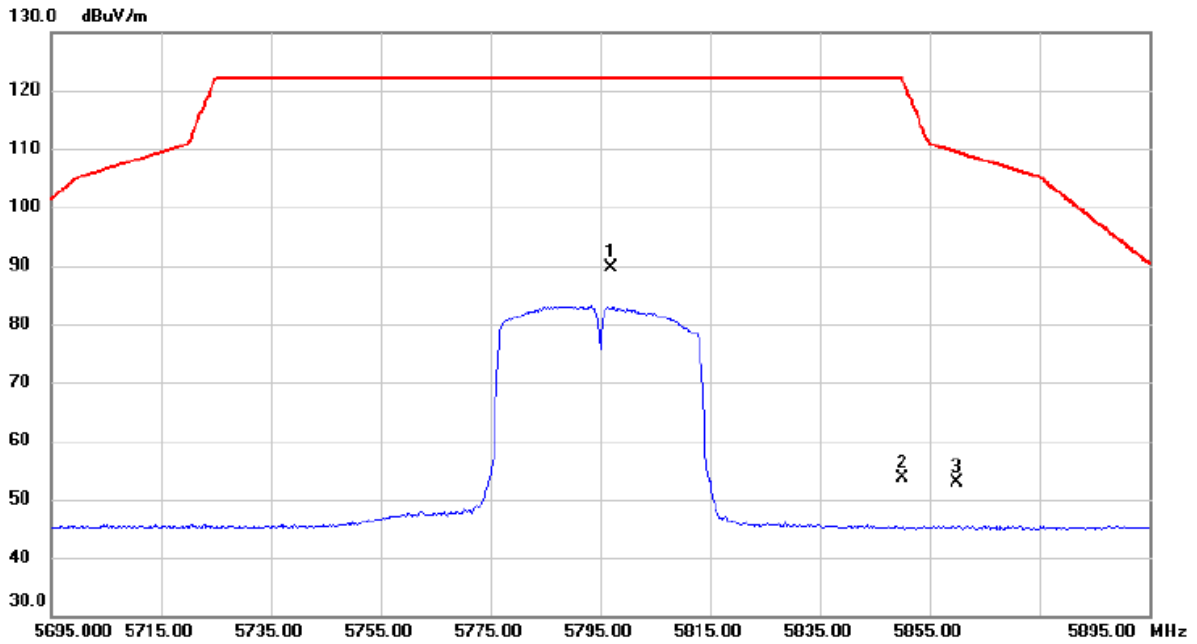

No.	Mk.	Freq. MHz	Reading Level dBuV	Correct Factor dB	Measure- ment dBuV/m	Limit dBuV/m	Margin dB	Detector	Comment
1	*	5797.000	73.58	16.04	89.62	122.20	-32.58	peak	No Limit
2		5850.000	37.53	16.16	53.69	122.20	-68.51	peak	
3		5860.000	36.74	16.18	52.92	109.40	-56.48	peak	

**REMARKS:**

- (1) Measurement Value = Reading Level + Correct Factor.
- (2) Margin Level = Measurement Value - Limit Value.

Orthogonal Axis	X
Test Mode	UNII-3_TX N (HT40) Mode 5795 MHz

**Vertical**

80 dBuV/m

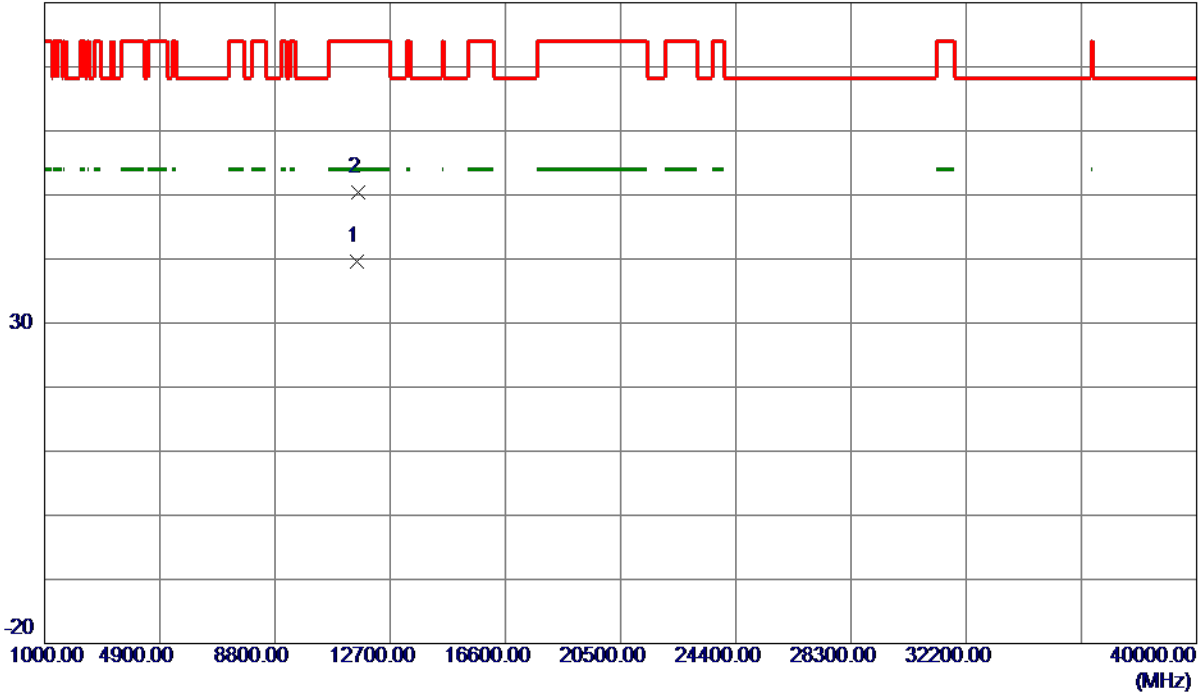

No.	Freq. MHz	Reading Level dBuV/m	Correct Factor dB	Measure ment dBuV/m	Limit dBuV/m	Margin dB	Detector	Comment
1 *	11583.2200	26.76	12.84	39.60	54.00	-14.40	AVG	
2	11598.2000	37.59	12.85	50.44	74.00	-23.56	Peak	

**REMARKS:**

- (1) Measurement Value = Reading Level + Correct Factor.
- (2) Margin Level = Measurement Value - Limit Value.

Orthogonal Axis	X
Test Mode	UNII-3_TX N (HT40) Mode 5795 MHz

### Horizontal

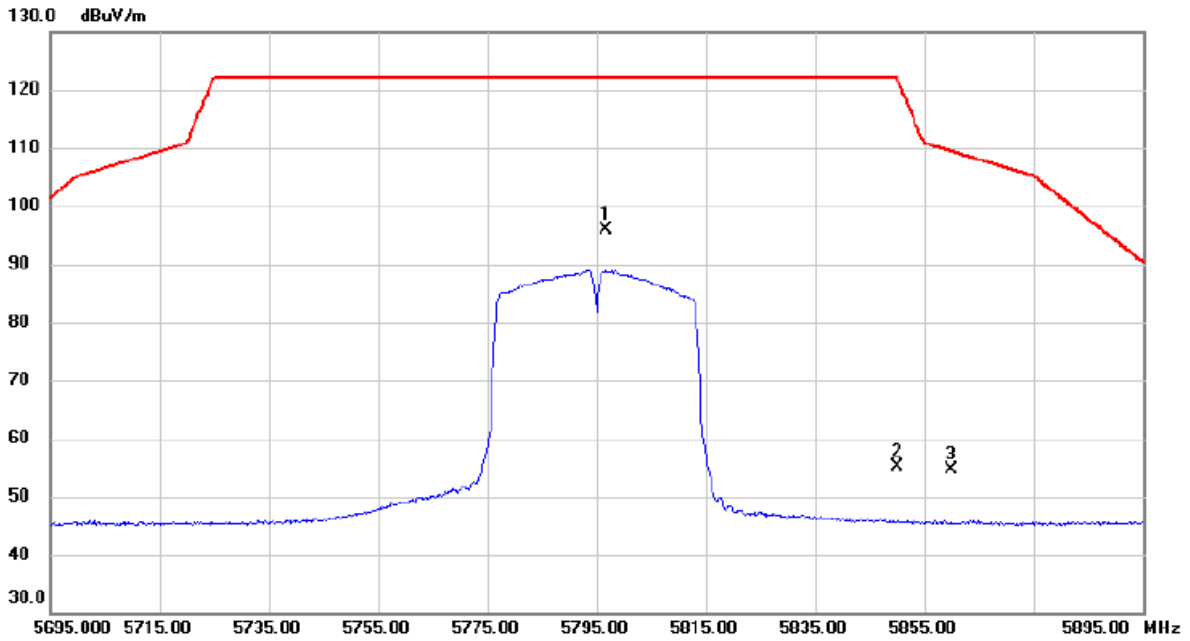

No.	Mk.	Freq. MHz	Reading Level dBuV	Correct Factor dB	Measure- ment dBuV/m	Limit dBuV/m	Margin dB	Detector	Comment
1	*	5796.800	79.77	16.04	95.81	122.20	-26.39	peak	No Limit
2		5850.000	39.03	16.16	55.19	122.20	-67.01	peak	
3		5860.000	38.39	16.18	54.57	109.40	-54.83	peak	

**REMARKS:**

- (1) Measurement Value = Reading Level + Correct Factor.
- (2) Margin Level = Measurement Value - Limit Value.

Orthogonal Axis	X
Test Mode	UNII-3_TX N (HT40) Mode 5795 MHz

### Horizontal

80 dBuV/m

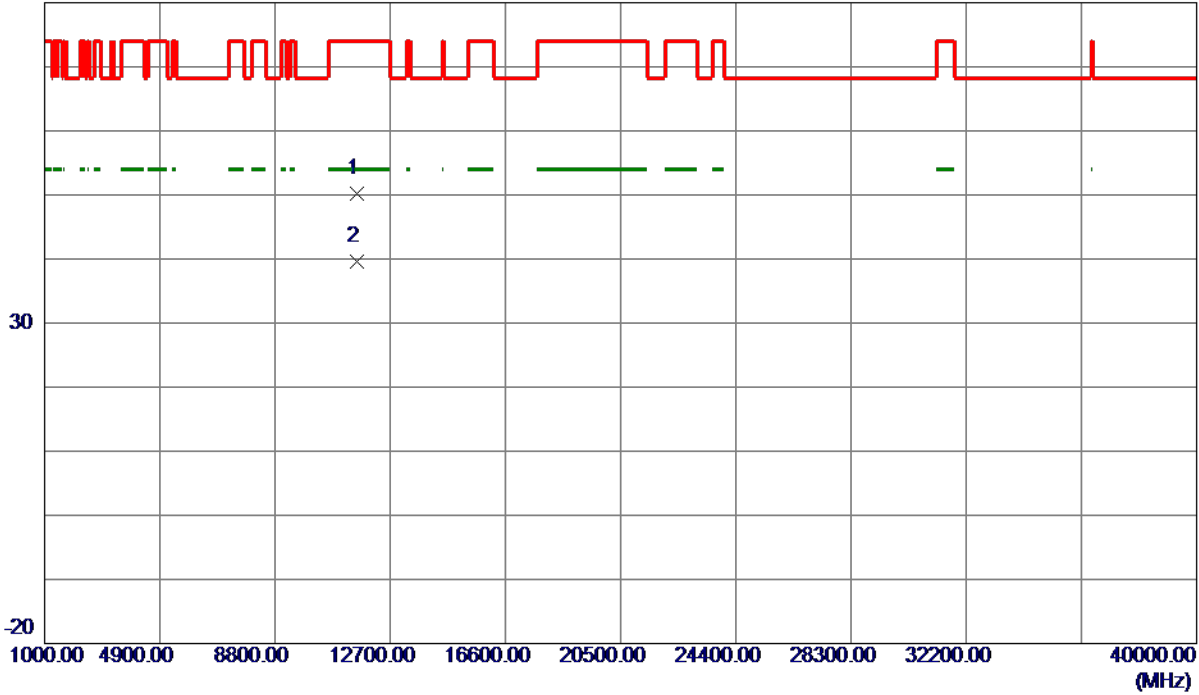

No.	Freq. MHz	Reading Level dBuV/m	Correct Factor dB	Measure ment dBuV/m	Limit dBuV/m	Margin dB	Detector	Comment
1	11580.6600	37.41	12.83	50.24	74.00	-23.76	Peak	
2 *	11583.8800	26.80	12.84	39.64	54.00	-14.36	AVG	

**REMARKS:**

- (1) Measurement Value = Reading Level + Correct Factor.
- (2) Margin Level = Measurement Value - Limit Value.



Orthogonal Axis	X
Test Mode	UNII-1_TX AC (VHT20) Mode 5180 MHz

**Vertical**

130 dBuV/m

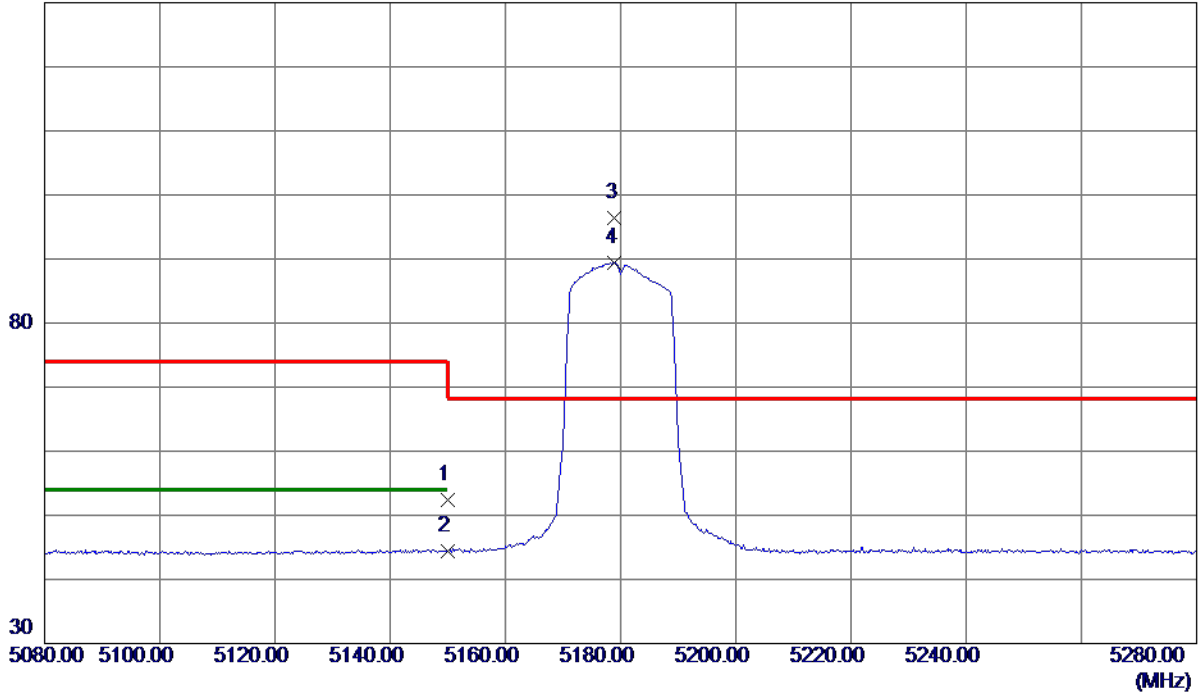

No.	Freq. MHz	Reading Level dBuV/m	Correct Factor dB	Measure ment dBuV/m	Limit dBuV/m	Margin dB	Detector	Comment
1	5150.0000	37.91	14.51	52.42	74.00	-21.58	Peak	
2	5150.0000	29.82	14.51	44.33	54.00	-9.67	AVG	
3 *	5179.0000	81.84	14.58	96.42	68.30	28.12	Peak	No Limit
4	5179.0000	74.91	14.58	89.49	999.00	-909.51	AVG	No Limit

**REMARKS:**

- (1) Measurement Value = Reading Level + Correct Factor.
- (2) Margin Level = Measurement Value - Limit Value.

Orthogonal Axis	X
Test Mode	UNII-1_TX AC (VHT20) Mode 5180 MHz

**Vertical**

80 dBuV/m

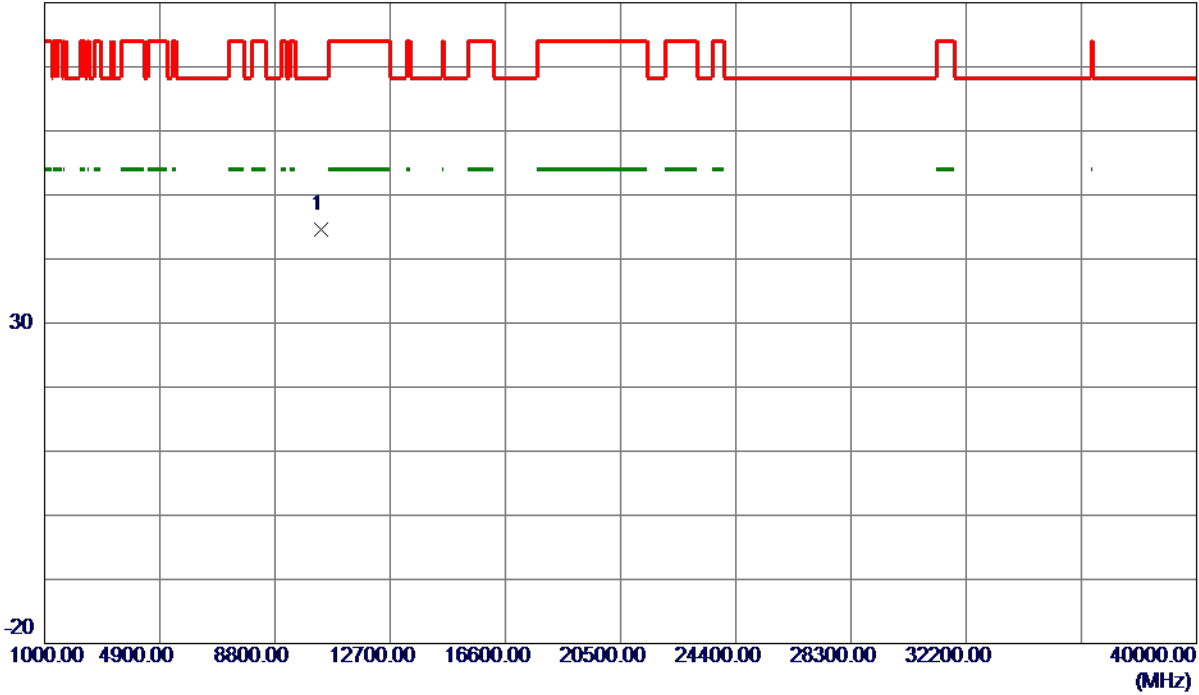

No.	Freq. MHz	Reading Level dBuV/m	Correct Factor dB	Measure ment dBuV/m	Limit dBuV/m	Margin dB	Detector	Comment
1 *	10362.5800	33.30	11.30	44.60	68.30	-23.70	Peak	

**REMARKS:**

- (1) Measurement Value = Reading Level + Correct Factor.
- (2) Margin Level = Measurement Value - Limit Value.

Orthogonal Axis	X
Test Mode	UNII-1_TX AC (VHT20) Mode 5180 MHz

### Horizontal

130 dBuV/m

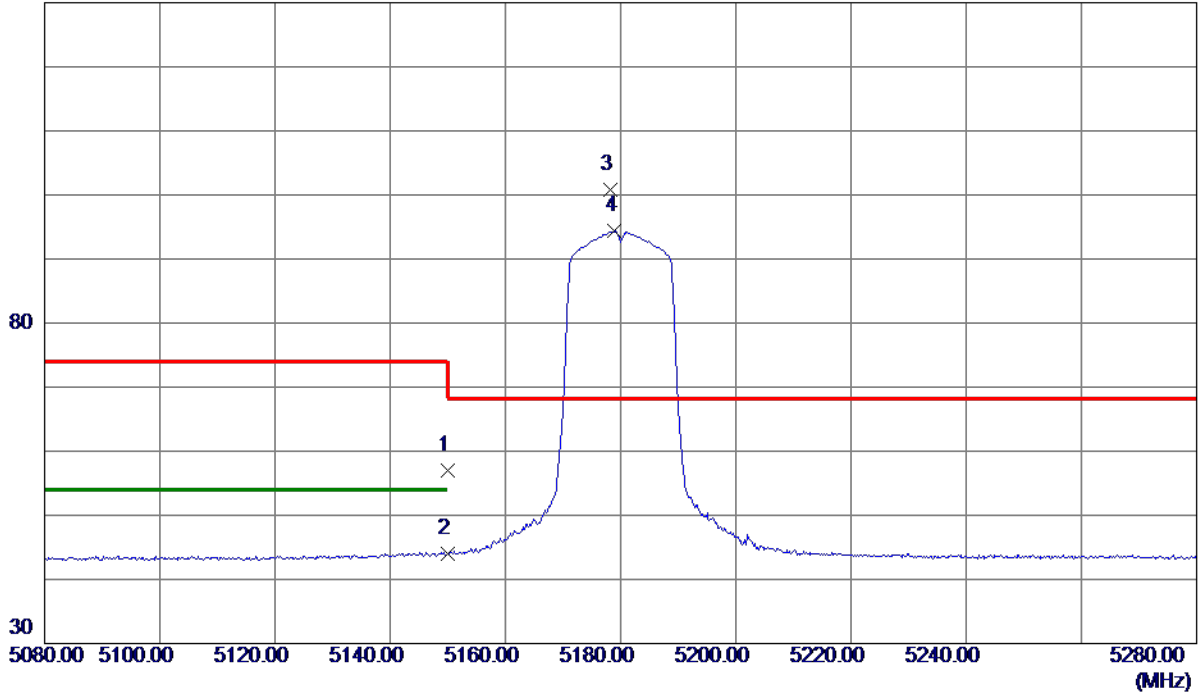

No.	Freq. MHz	Reading Level dBuV/m	Correct Factor dB	Measure ment dBuV/m	Limit dBuV/m	Margin dB	Detector	Comment
1	5150.0000	42.42	14.51	56.93	74.00	-17.07	Peak	
2	5150.0000	29.45	14.51	43.96	54.00	-10.04	AVG	
3 *	5178.2000	86.26	14.58	100.84	68.30	32.54	Peak	No Limit
4	5179.0000	79.82	14.58	94.40	999.00	-904.60	AVG	No Limit

**REMARKS:**

- (1) Measurement Value = Reading Level + Correct Factor.
- (2) Margin Level = Measurement Value - Limit Value.

Orthogonal Axis	X
Test Mode	UNII-1_TX AC (VHT20) Mode 5180 MHz

### Horizontal

80 dBuV/m

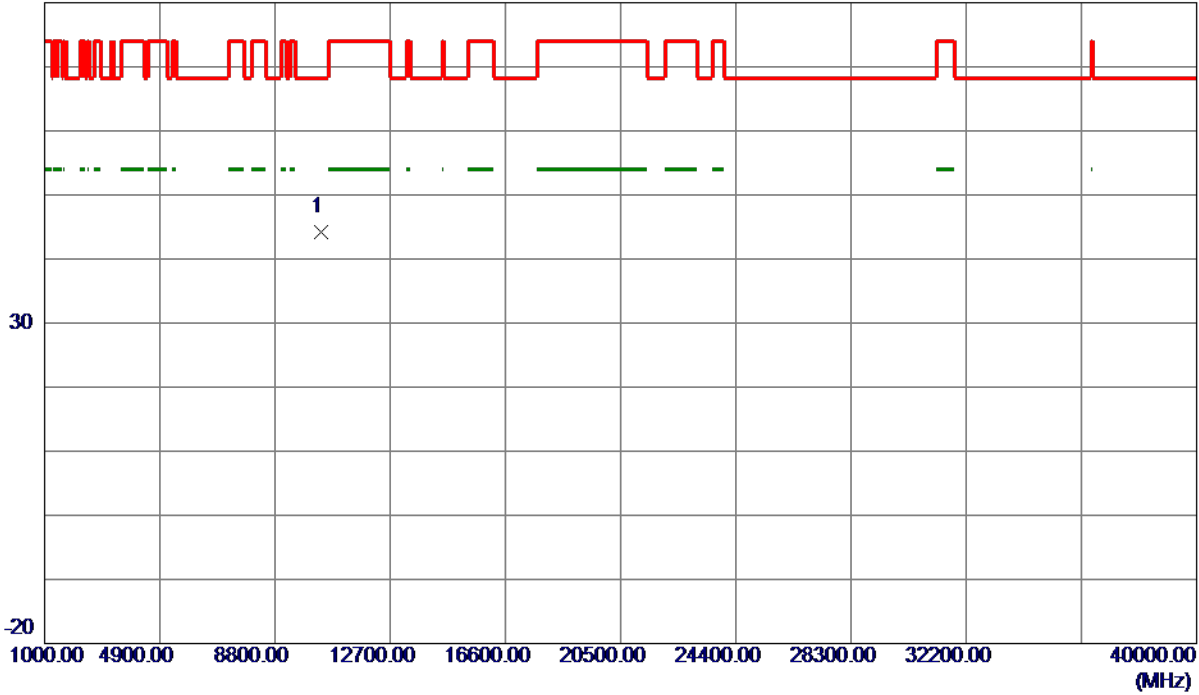

No.	Freq. MHz	Reading Level dBuV/m	Correct Factor dB	Measure ment dBuV/m	Limit dBuV/m	Margin dB	Detector	Comment
1 *	10356.3550	32.96	11.29	44.25	68.30	-24.05	Peak	

**REMARKS:**

- (1) Measurement Value = Reading Level + Correct Factor.
- (2) Margin Level = Measurement Value - Limit Value.

Orthogonal Axis	X
Test Mode	UNII-1_TX AC (VHT20) Mode 5200 MHz

**Vertical**

130 dBuV/m

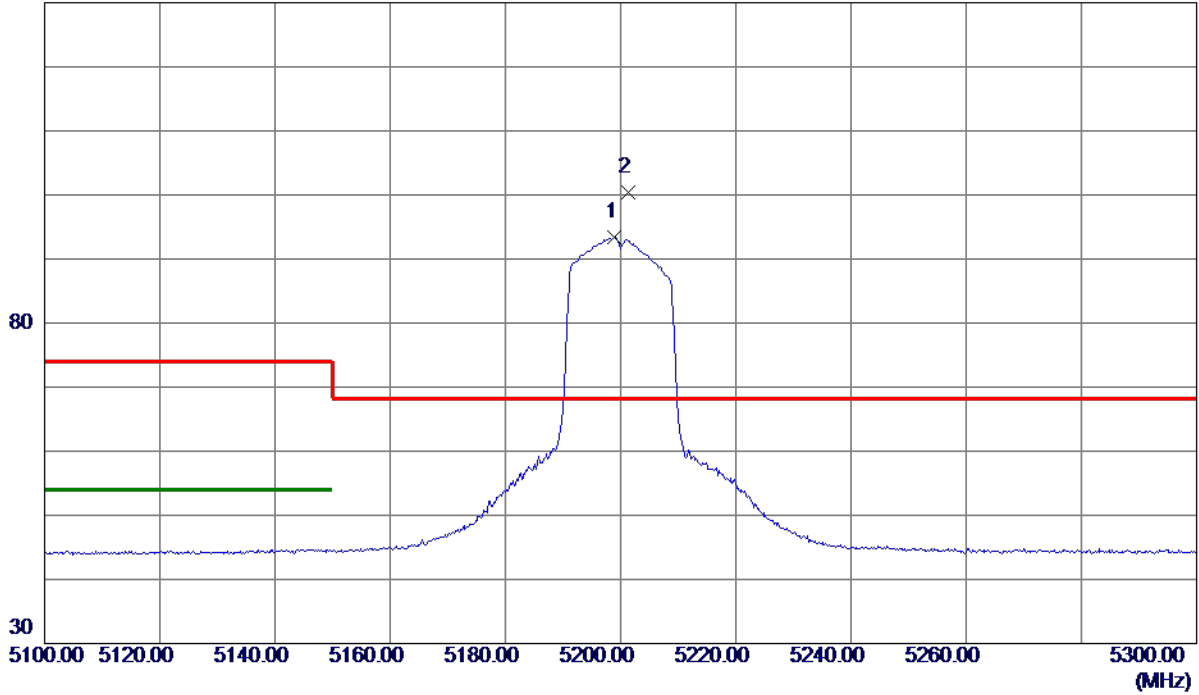

No.	Freq. MHz	Reading Level dBuV/m	Correct Factor dB	Measure ment dBuV/m	Limit dBuV/m	Margin dB	Detector	Comment
1	5199.0000	78.83	14.63	93.46	999.00	-905.54	AVG	No Limit
2 *	5201.4000	85.74	14.64	100.38	68.30	32.08	Peak	No Limit

**REMARKS:**

- (1) Measurement Value = Reading Level + Correct Factor.
- (2) Margin Level = Measurement Value - Limit Value.

Orthogonal Axis	X
Test Mode	UNII-1_TX AC (VHT20) Mode 5200 MHz

**Vertical**

80 dBuV/m

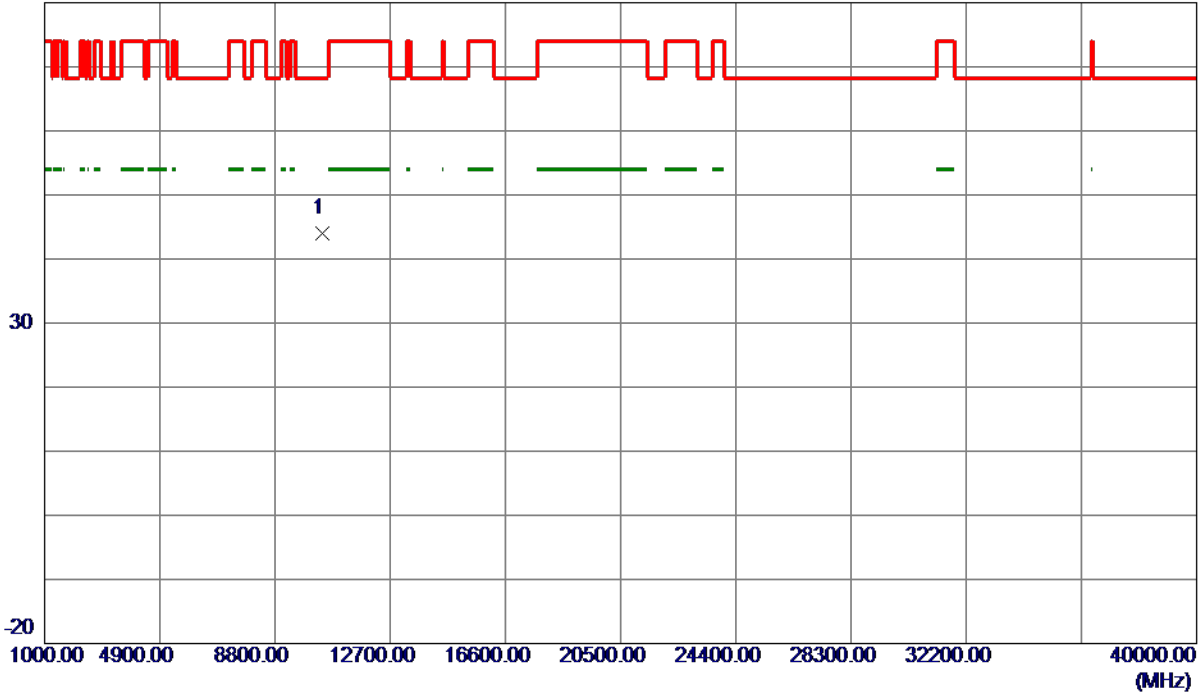

No.	Freq. MHz	Reading Level dBuV/m	Correct Factor dB	Measure ment dBuV/m	Limit dBuV/m	Margin dB	Detector	Comment
1 *	10402.2750	32.59	11.37	43.96	68.30	-24.34	Peak	

**REMARKS:**

- (1) Measurement Value = Reading Level + Correct Factor.
- (2) Margin Level = Measurement Value - Limit Value.

Orthogonal Axis	X
Test Mode	UNII-1_TX AC (VHT20) Mode 5200 MHz

### Horizontal

130 dBuV/m

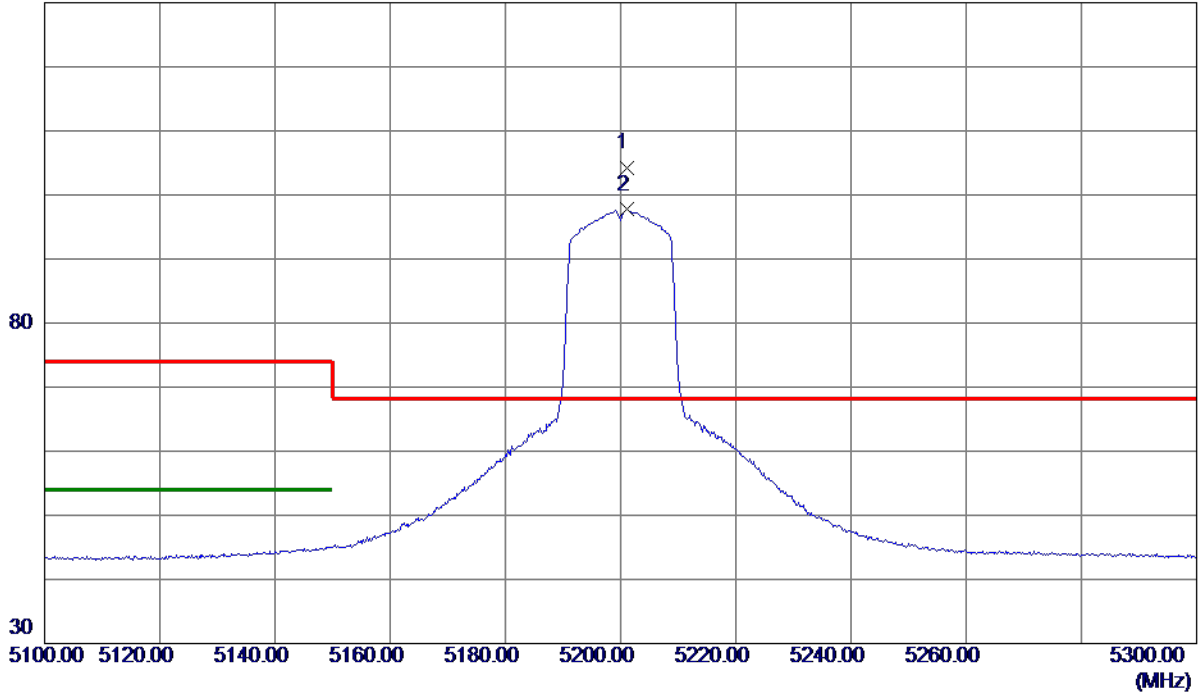

No.	Freq. MHz	Reading Level dBuV/m	Correct Factor dB	Measure ment dBuV/m	Limit dBuV/m	Margin dB	Detector	Comment
1 *	5201.0000	89.63	14.64	104.27	68.30	35.97	Peak	No Limit
2	5201.2000	83.06	14.64	97.70	999.00	-901.30	AVG	No Limit

**REMARKS:**

- (1) Measurement Value = Reading Level + Correct Factor.
- (2) Margin Level = Measurement Value - Limit Value.

Orthogonal Axis	X
Test Mode	UNII-1_TX AC (VHT20) Mode 5200 MHz

### Horizontal

80 dBuV/m

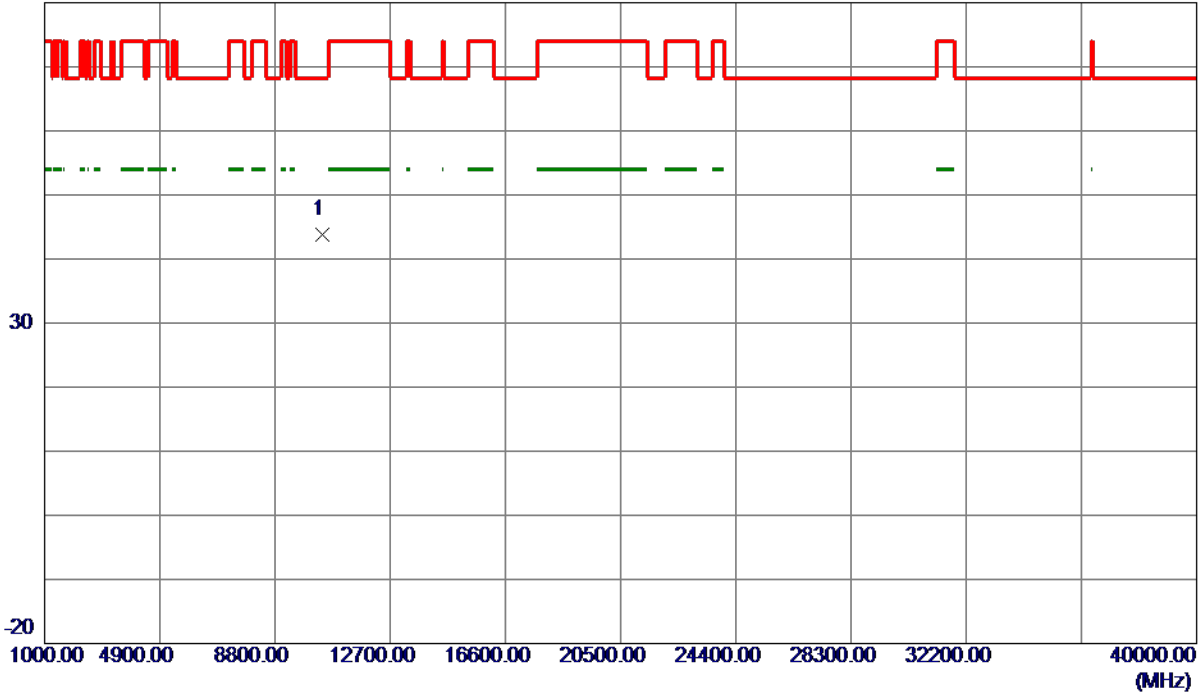

No.	Freq. MHz	Reading Level dBuV/m	Correct Factor dB	Measure ment dBuV/m	Limit dBuV/m	Margin dB	Detector	Comment
1 *	10397.3099	32.53	11.36	43.89	68.30	-24.41	Peak	

**REMARKS:**

- (1) Measurement Value = Reading Level + Correct Factor.
- (2) Margin Level = Measurement Value - Limit Value.



Orthogonal Axis	X
Test Mode	UNII-1_TX AC (VHT20) Mode 5240 MHz

**Vertical**

130 dBuV/m

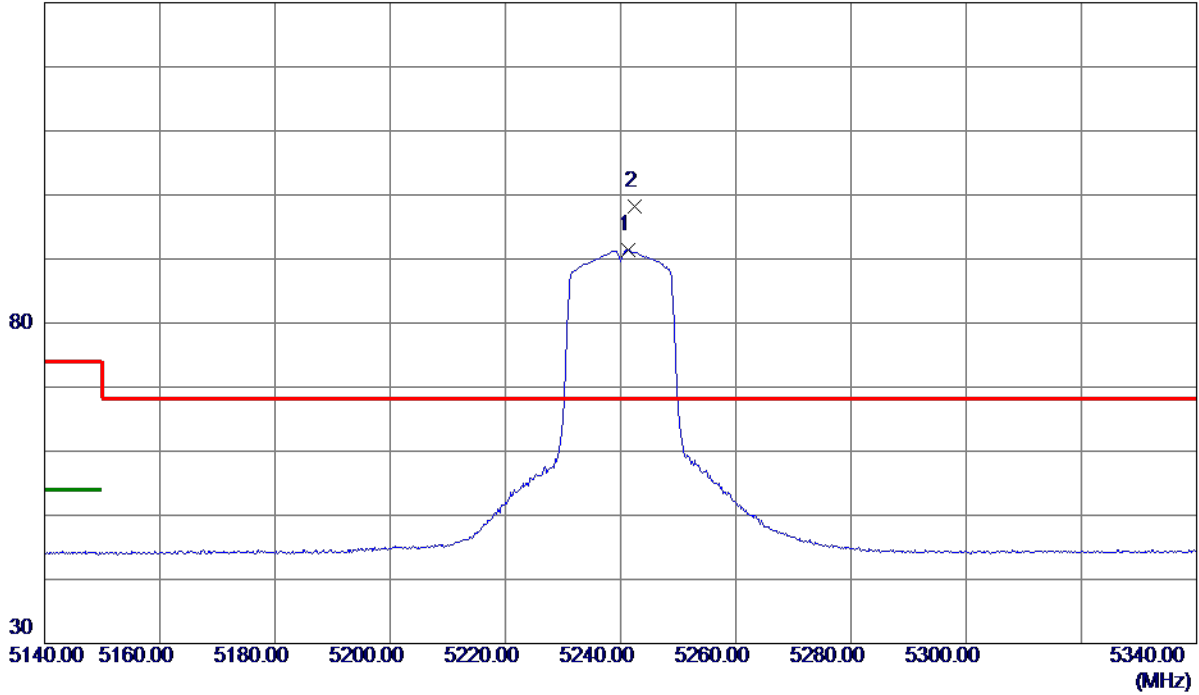

No.	Freq. MHz	Reading Level dBuV/m	Correct Factor dB	Measure ment dBuV/m	Limit dBuV/m	Margin dB	Detector	Comment
1	5241.4000	76.63	14.74	91.37	999.00	-907.63	AVG	No Limit
2 *	5242.4000	83.49	14.74	98.23	68.30	29.93	Peak	No Limit

**REMARKS:**

- (1) Measurement Value = Reading Level + Correct Factor.
- (2) Margin Level = Measurement Value - Limit Value.

Orthogonal Axis	X
Test Mode	UNII-1_TX AC (VHT20) Mode 5240 MHz

**Vertical**

80 dBuV/m

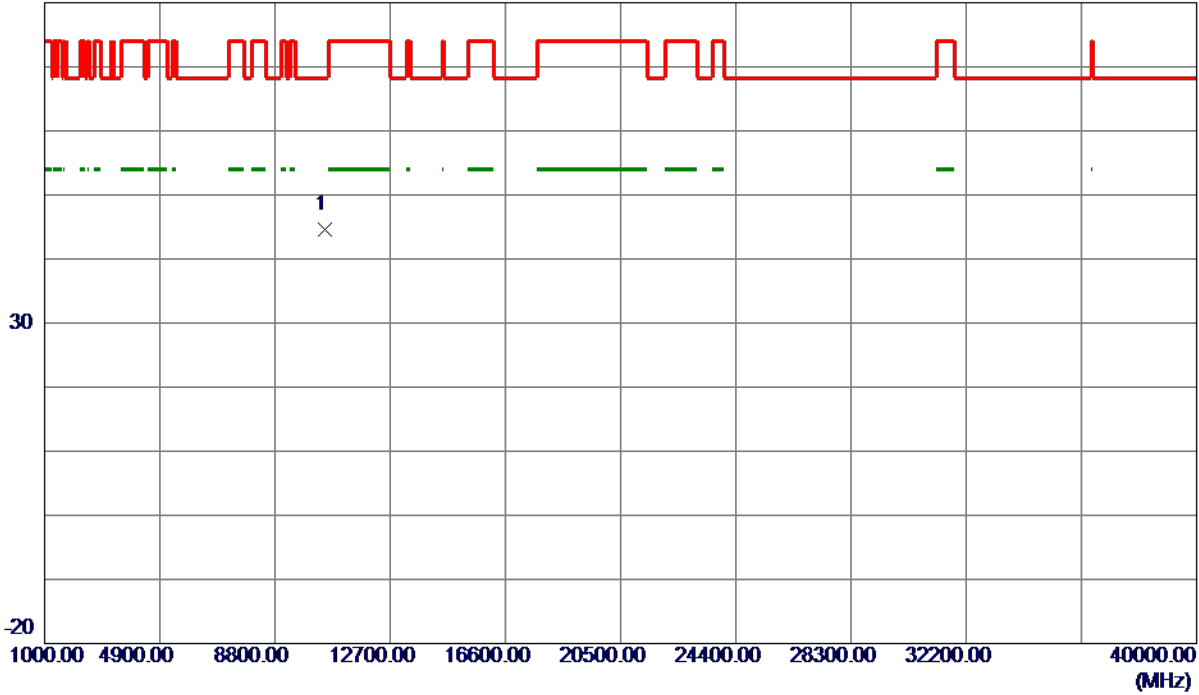

No.	Freq. MHz	Reading Level dBuV/m	Correct Factor dB	Measure ment dBuV/m	Limit dBuV/m	Margin dB	Detector	Comment
1 *	10480.4200	33.05	11.50	44.55	68.30	-23.75	Peak	

**REMARKS:**

- (1) Measurement Value = Reading Level + Correct Factor.
- (2) Margin Level = Measurement Value - Limit Value.

Orthogonal Axis	X
Test Mode	UNII-1_TX AC (VHT20) Mode 5240 MHz

### Horizontal

130 dBuV/m

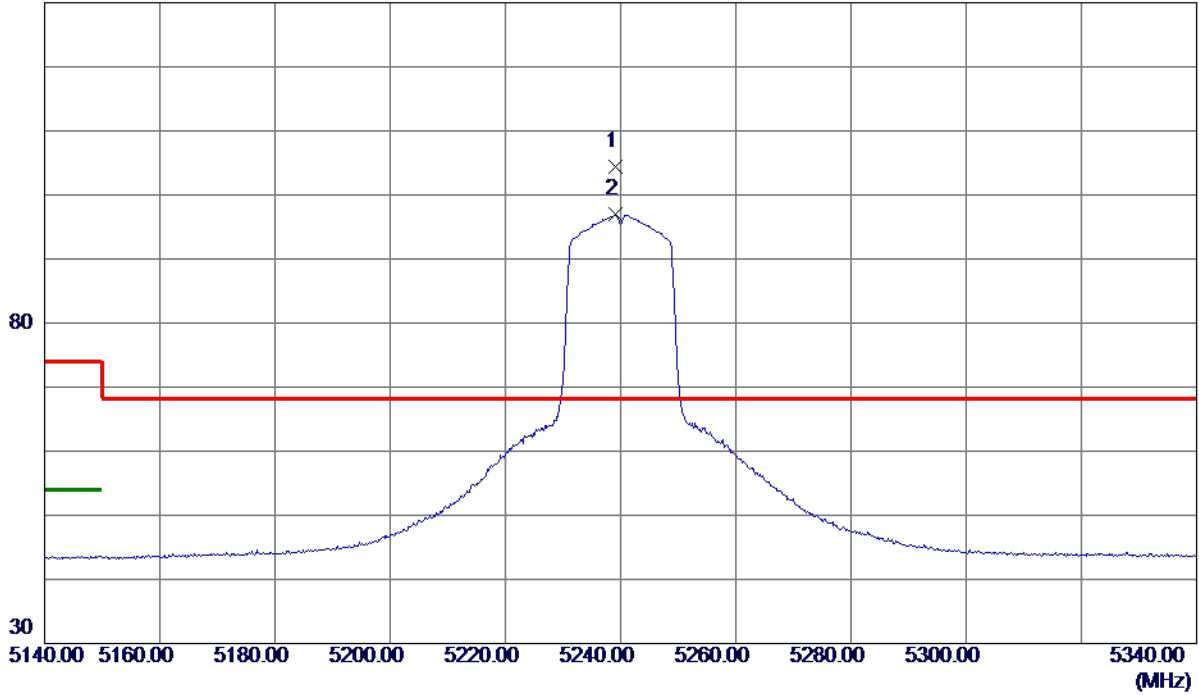

No.	Freq. MHz	Reading Level dBuV/m	Correct Factor dB	Measure ment dBuV/m	Limit dBuV/m	Margin dB	Detector	Comment
1 *	5239.2000	89.70	14.74	104.44	68.30	36.14	Peak	No Limit
2	5239.2000	82.31	14.74	97.05	999.00	-901.95	AVG	No Limit

**REMARKS:**

- (1) Measurement Value = Reading Level + Correct Factor.
- (2) Margin Level = Measurement Value - Limit Value.

Orthogonal Axis	X
Test Mode	UNII-1_TX AC (VHT20) Mode 5240 MHz

### Horizontal

80 dBuV/m

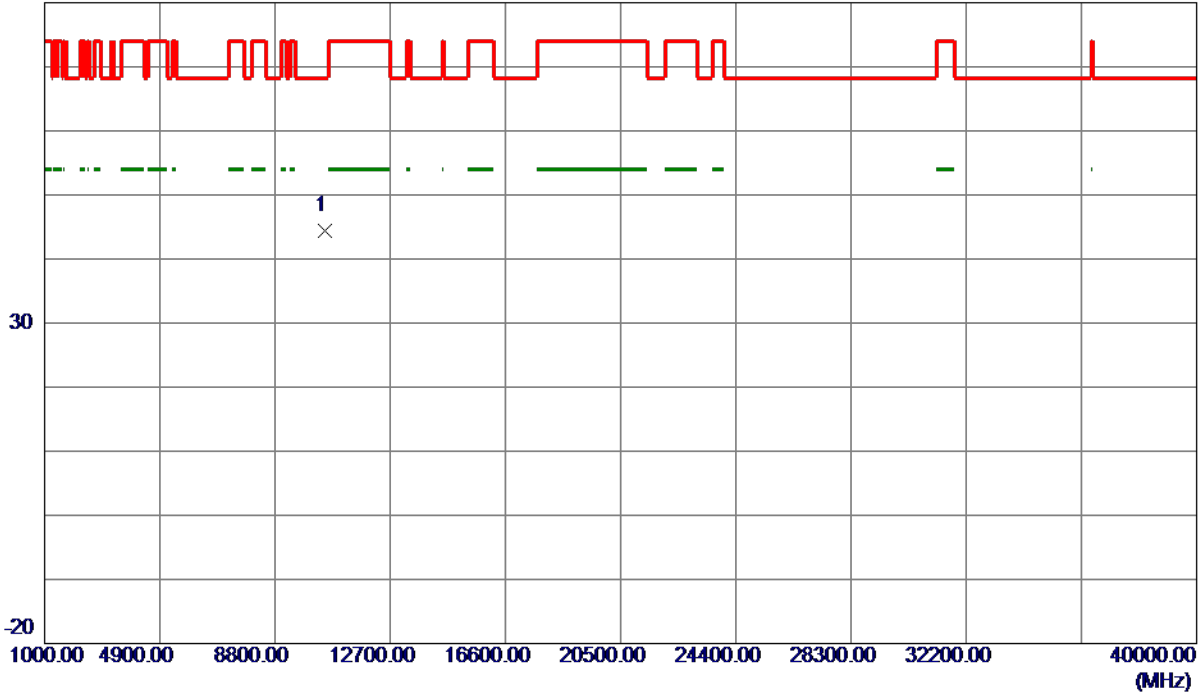

No.	Freq. MHz	Reading Level dBuV/m	Correct Factor dB	Measure ment dBuV/m	Limit dBuV/m	Margin dB	Detector	Comment
1 *	10478.1400	32.84	11.50	44.34	68.30	-23.96	Peak	

**REMARKS:**

- (1) Measurement Value = Reading Level + Correct Factor.
- (2) Margin Level = Measurement Value - Limit Value.

Orthogonal Axis	X
Test Mode	UNII-1_TX AC (VHT40) Mode 5190 MHz

**Vertical**

130 dBuV/m

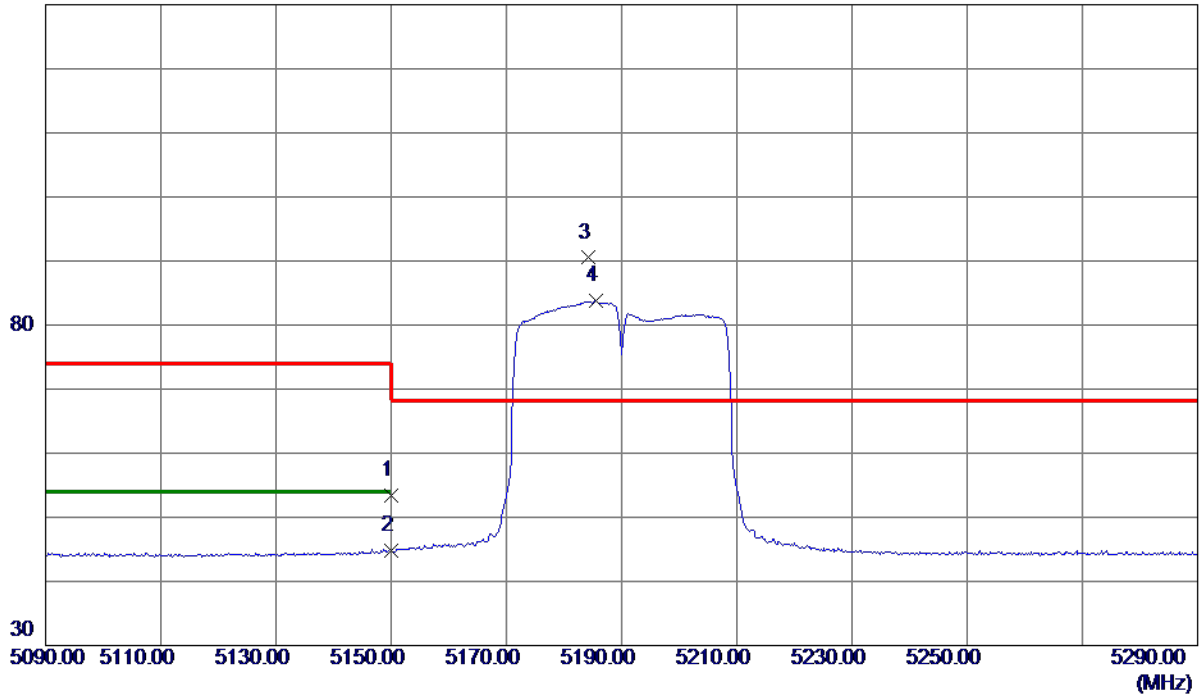

No.	Freq. MHz	Reading Level dBuV/m	Correct Factor dB	Measure ment dBuV/m	Limit dBuV/m	Margin dB	Detector	Comment
1	5150.0000	38.87	14.51	53.38	74.00	-20.62	Peak	
2	5150.0000	30.32	14.51	44.83	54.00	-9.17	AVG	
3 *	5184.2000	75.90	14.60	90.50	68.30	22.20	Peak	No Limit
4	5185.6000	69.17	14.60	83.77	999.00	-915.23	AVG	No Limit

**REMARKS:**

- (1) Measurement Value = Reading Level + Correct Factor.
- (2) Margin Level = Measurement Value - Limit Value.

Orthogonal Axis	X
Test Mode	UNII-1_TX AC (VHT40) Mode 5190 MHz

**Vertical**

80 dBuV/m

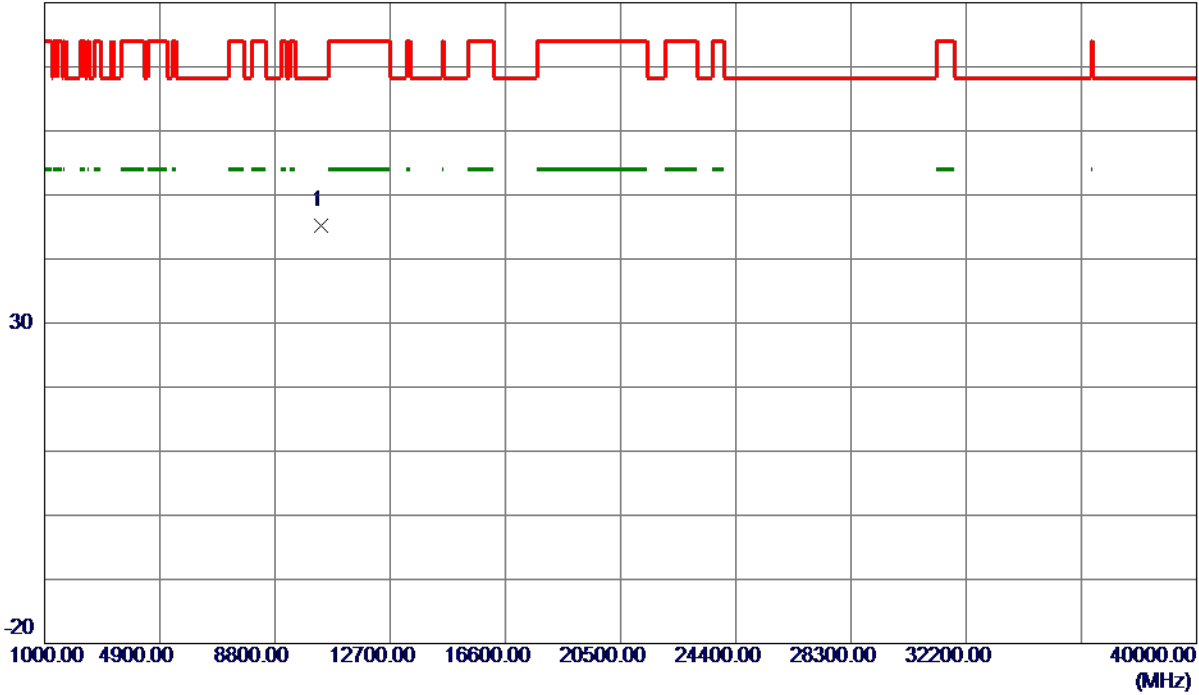

No.	Freq. MHz	Reading Level dBuV/m	Correct Factor dB	Measure ment dBuV/m	Limit dBuV/m	Margin dB	Detector	Comment
1 *	10381.0000	33.79	11.33	45.12	68.30	-23.18	Peak	

**REMARKS:**

- (1) Measurement Value = Reading Level + Correct Factor.
- (2) Margin Level = Measurement Value - Limit Value.

Orthogonal Axis	X
Test Mode	UNII-1_TX AC (VHT40) Mode 5190 MHz

### Horizontal

130 dBuV/m

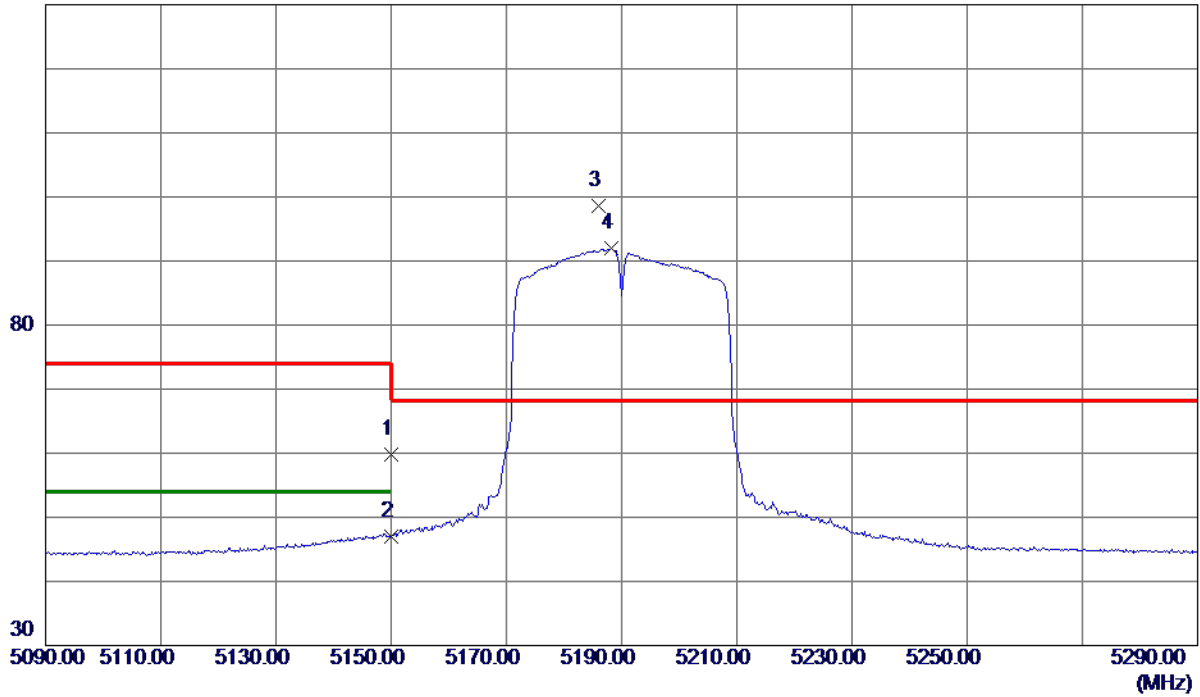

No.	Freq. MHz	Reading Level dBuV/m	Correct Factor dB	Measure ment dBuV/m	Limit dBuV/m	Margin dB	Detector	Comment
1	5150.0000	45.35	14.51	59.86	74.00	-14.14	Peak	
2	5150.0000	32.46	14.51	46.97	54.00	-7.03	AVG	
3 *	5186.0000	84.01	14.60	98.61	68.30	30.31	Peak	No Limit
4	5188.2000	77.31	14.61	91.92	999.00	-907.08	AVG	No Limit

**REMARKS:**

- (1) Measurement Value = Reading Level + Correct Factor.
- (2) Margin Level = Measurement Value - Limit Value.

Orthogonal Axis	X
Test Mode	UNII-1_TX AC (VHT40) Mode 5190 MHz

### Horizontal

80 dBuV/m

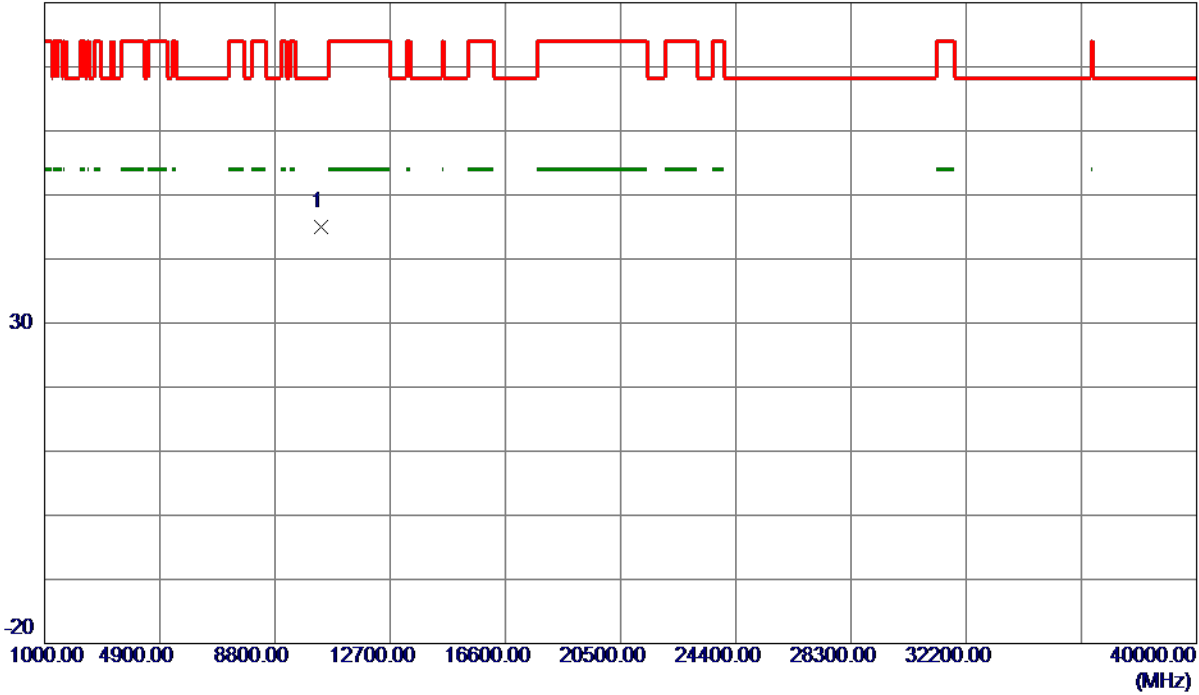

No.	Freq. MHz	Reading Level dBuV/m	Correct Factor dB	Measure ment dBuV/m	Limit dBuV/m	Margin dB	Detector	Comment
1 *	10376.7100	33.62	11.33	44.95	68.30	-23.35	Peak	

**REMARKS:**

- (1) Measurement Value = Reading Level + Correct Factor.
- (2) Margin Level = Measurement Value - Limit Value.



Orthogonal Axis	X
Test Mode	UNII-1_TX AC (VHT40) Mode 5230 MHz

**Vertical**

130 dBuV/m

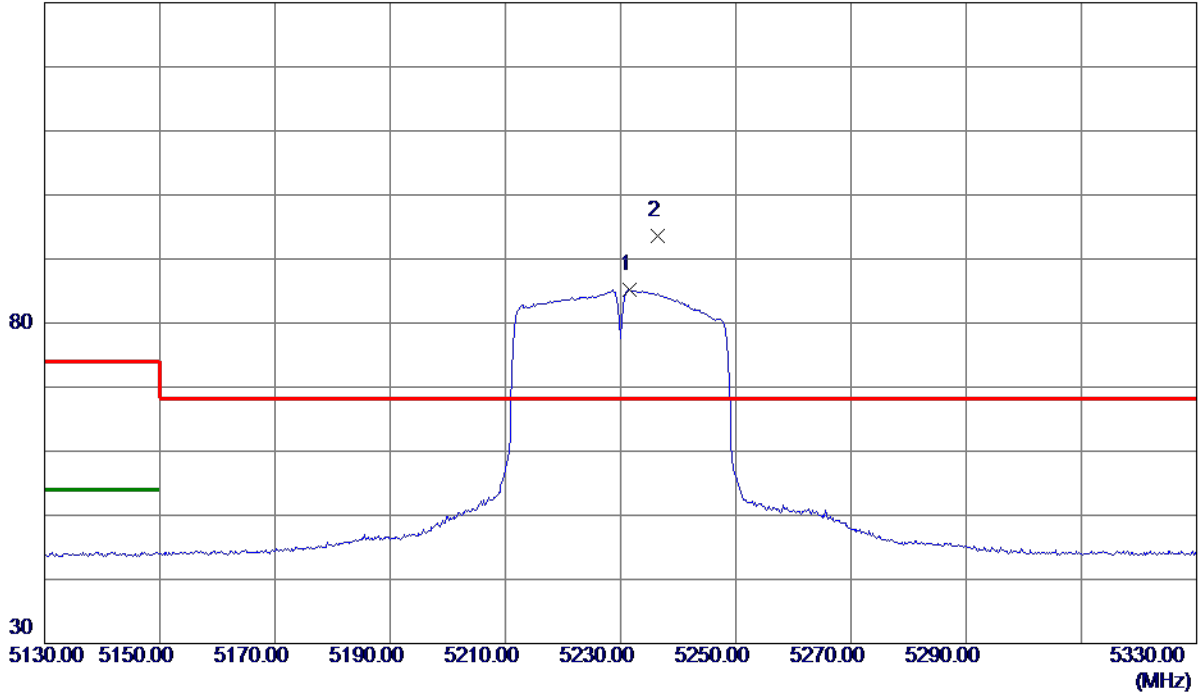

No.	Freq. MHz	Reading Level dBuV/m	Correct Factor dB	Measure ment dBuV/m	Limit dBuV/m	Margin dB	Detector	Comment
1	5231.6000	70.45	14.72	85.17	999.00	-913.83	AVG	No Limit
2 *	5236.4000	78.79	14.73	93.52	68.30	25.22	Peak	No Limit

**REMARKS:**

- (1) Measurement Value = Reading Level + Correct Factor.
- (2) Margin Level = Measurement Value - Limit Value.

Orthogonal Axis	X
Test Mode	UNII-1_TX AC (VHT40) Mode 5230 MHz

**Vertical**

80 dBuV/m



No.	Freq. MHz	Reading Level dBuV/m	Correct Factor dB	Measure ment dBuV/m	Limit dBuV/m	Margin dB	Detector	Comment
1 *	10457.2050	33.22	11.46	44.68	68.30	-23.62	Peak	

**REMARKS:**

- (1) Measurement Value = Reading Level + Correct Factor.
- (2) Margin Level = Measurement Value - Limit Value.

Orthogonal Axis	X
Test Mode	UNII-1_TX AC (VHT40) Mode 5230 MHz

### Horizontal

130 dBuV/m

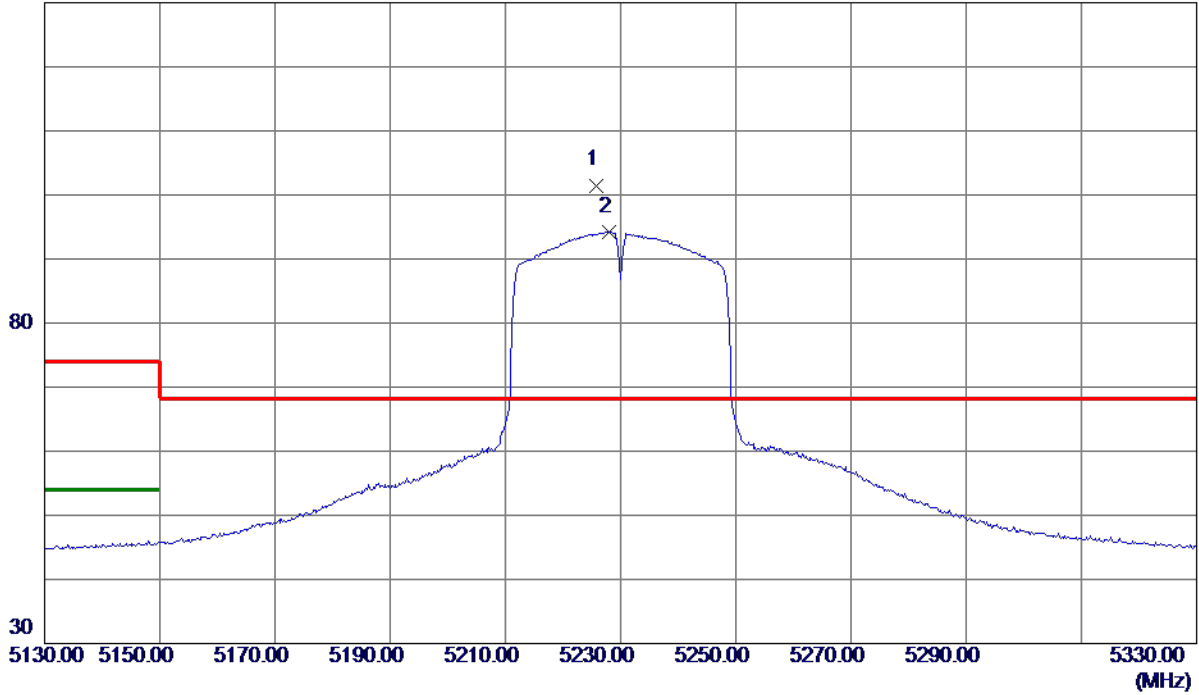

No.	Freq. MHz	Reading Level dBuV/m	Correct Factor dB	Measure ment dBuV/m	Limit dBuV/m	Margin dB	Detector	Comment
1 *	5225.8000	86.80	14.70	101.50	68.30	33.20	Peak	No Limit
2	5228.0000	79.58	14.71	94.29	999.00	-904.71	AVG	No Limit

**REMARKS:**

- (1) Measurement Value = Reading Level + Correct Factor.
- (2) Margin Level = Measurement Value - Limit Value.

Orthogonal Axis	X
Test Mode	UNII-1_TX AC (VHT40) Mode 5230 MHz

### Horizontal

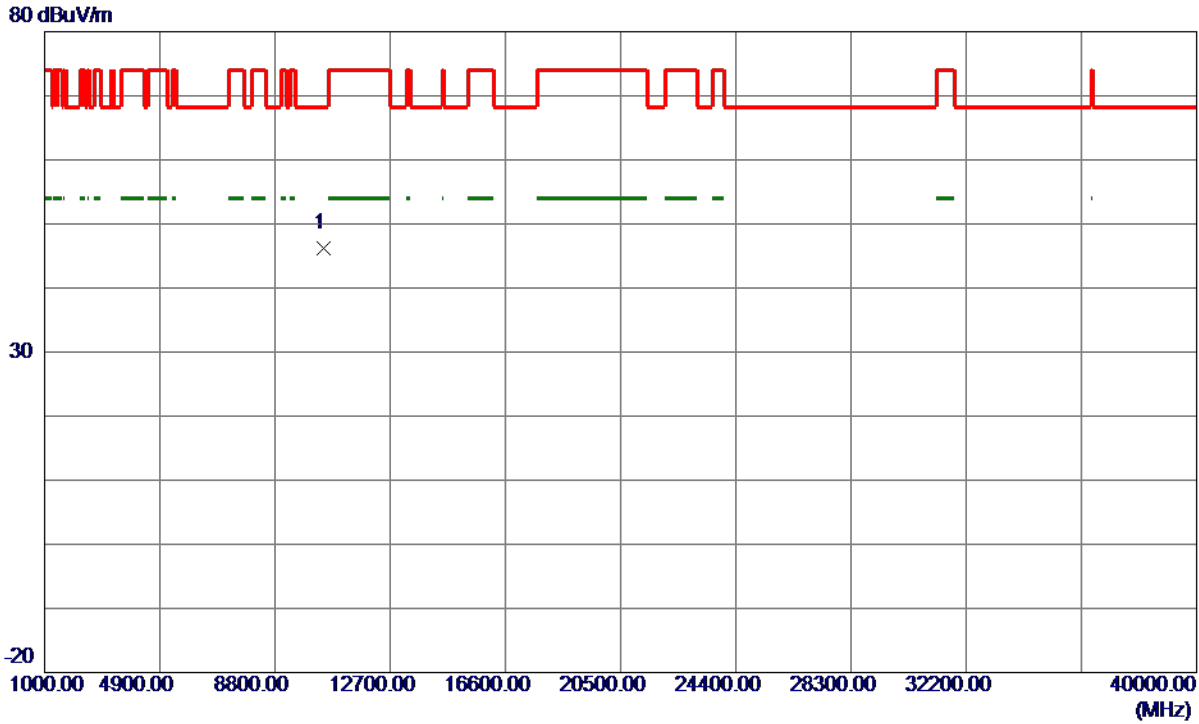

No.	Freq. MHz	Reading Level dBuV/m	Correct Factor dB	Measure ment dBuV/m	Limit dBuV/m	Margin dB	Detector	Comment
1 *	10455.0300	34.79	11.46	46.25	68.30	-22.05	Peak	

**REMARKS:**

- (1) Measurement Value = Reading Level + Correct Factor.
- (2) Margin Level = Measurement Value - Limit Value.

Orthogonal Axis	X
Test Mode	UNII-1_TX AC (VHT80) Mode 5210 MHz

**Vertical**

130 dBuV/m

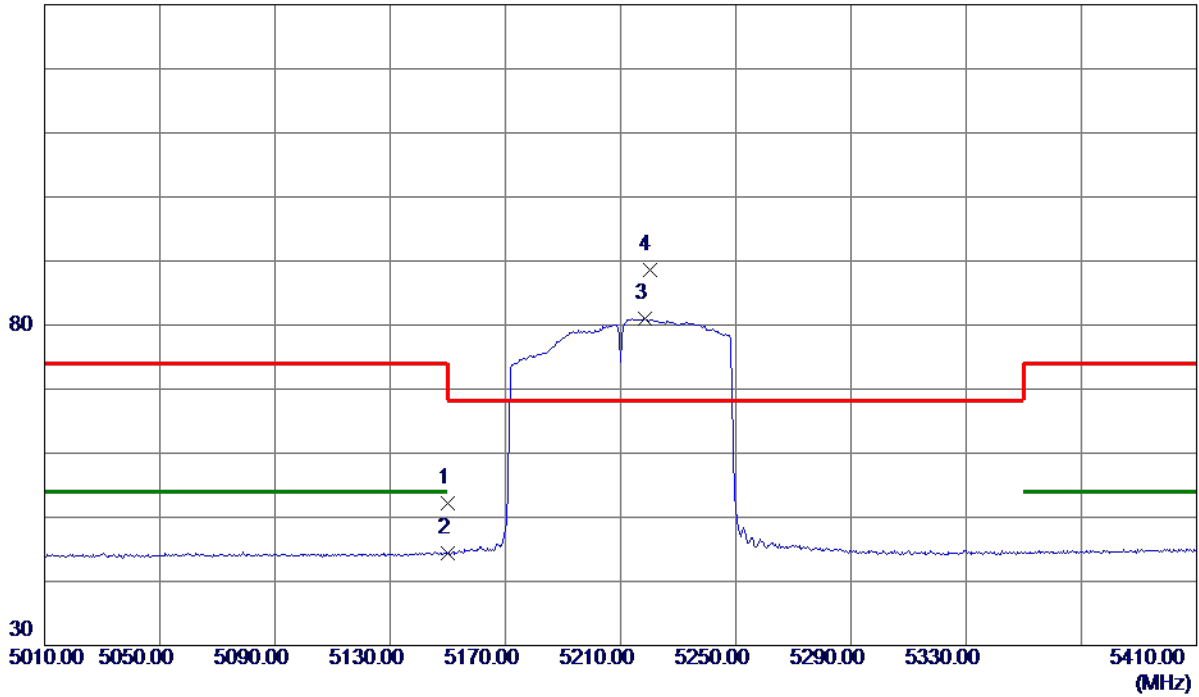

No.	Freq. MHz	Reading Level dBuV/m	Correct Factor dB	Measure ment dBuV/m	Limit dBuV/m	Margin dB	Detector	Comment
1	5150.0000	37.78	14.51	52.29	74.00	-21.71	Peak	
2	5150.0000	29.91	14.51	44.42	54.00	-9.58	AVG	
3	5218.4000	66.28	14.68	80.96	999.00	-918.04	AVG	No Limit
4 *	5220.0000	73.92	14.69	88.61	68.30	20.31	Peak	No Limit

**REMARKS:**

- (1) Measurement Value = Reading Level + Correct Factor.
- (2) Margin Level = Measurement Value - Limit Value.

Orthogonal Axis	X
Test Mode	UNII-1_TX AC (VHT80) Mode 5210 MHz

**Vertical**

80 dBuV/m

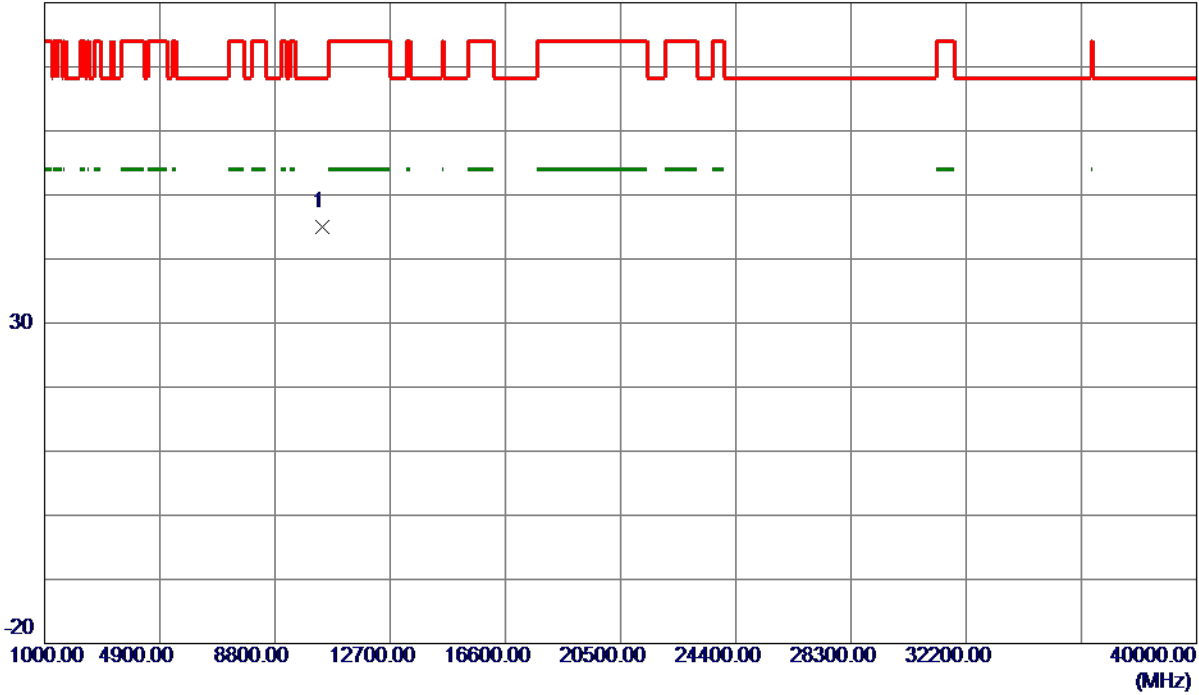

No.	Freq. MHz	Reading Level dBuV/m	Correct Factor dB	Measure ment dBuV/m	Limit dBuV/m	Margin dB	Detector	Comment
1 *	10422.8450	33.62	11.40	45.02	68.30	-23.28	Peak	

**REMARKS:**

- (1) Measurement Value = Reading Level + Correct Factor.
- (2) Margin Level = Measurement Value - Limit Value.

Orthogonal Axis	X
Test Mode	UNII-1_TX AC (VHT80) Mode 5210 MHz

### Horizontal

130 dBuV/m

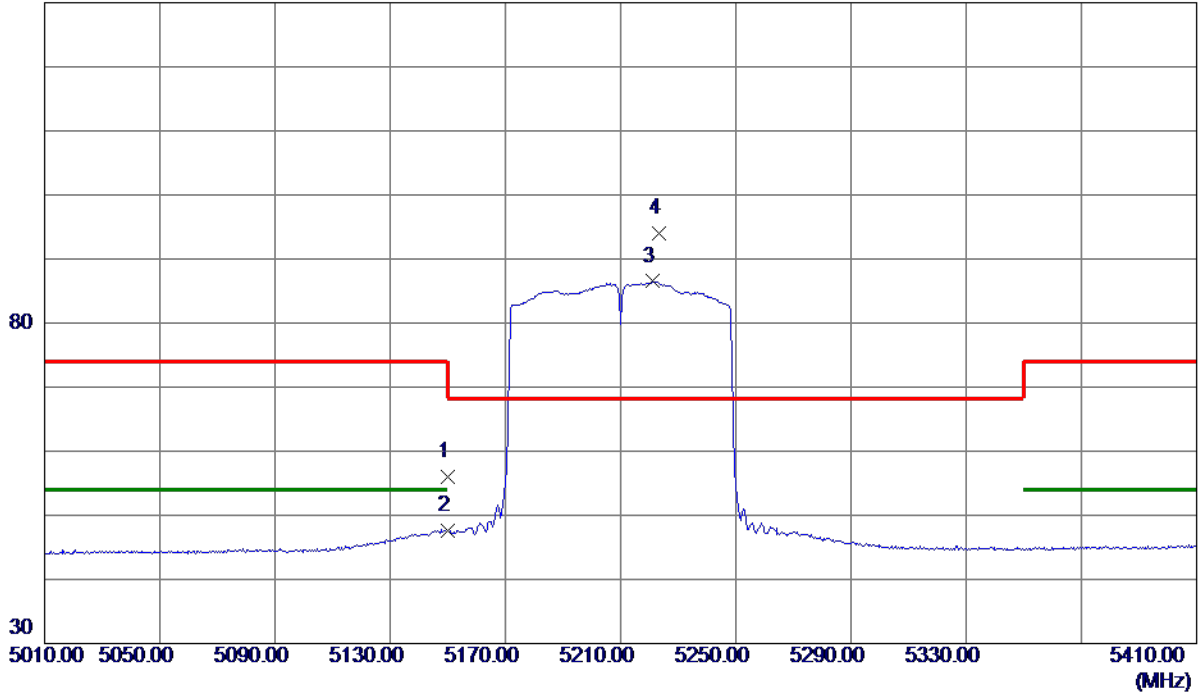

No.	Freq. MHz	Reading Level dBuV/m	Correct Factor dB	Measure ment dBuV/m	Limit dBuV/m	Margin dB	Detector	Comment
1	5150.0000	41.54	14.51	56.05	74.00	-17.95	Peak	
2	5150.0000	33.16	14.51	47.67	54.00	-6.33	AVG	
3	5221.2000	71.81	14.69	86.50	999.00	-912.50	AVG	No Limit
4 *	5223.2000	79.41	14.69	94.10	68.30	25.80	Peak	No Limit

**REMARKS:**

- (1) Measurement Value = Reading Level + Correct Factor.
- (2) Margin Level = Measurement Value - Limit Value.

Orthogonal Axis	X
Test Mode	UNII-1_TX AC (VHT80) Mode 5210 MHz

### Horizontal

80 dBuV/m

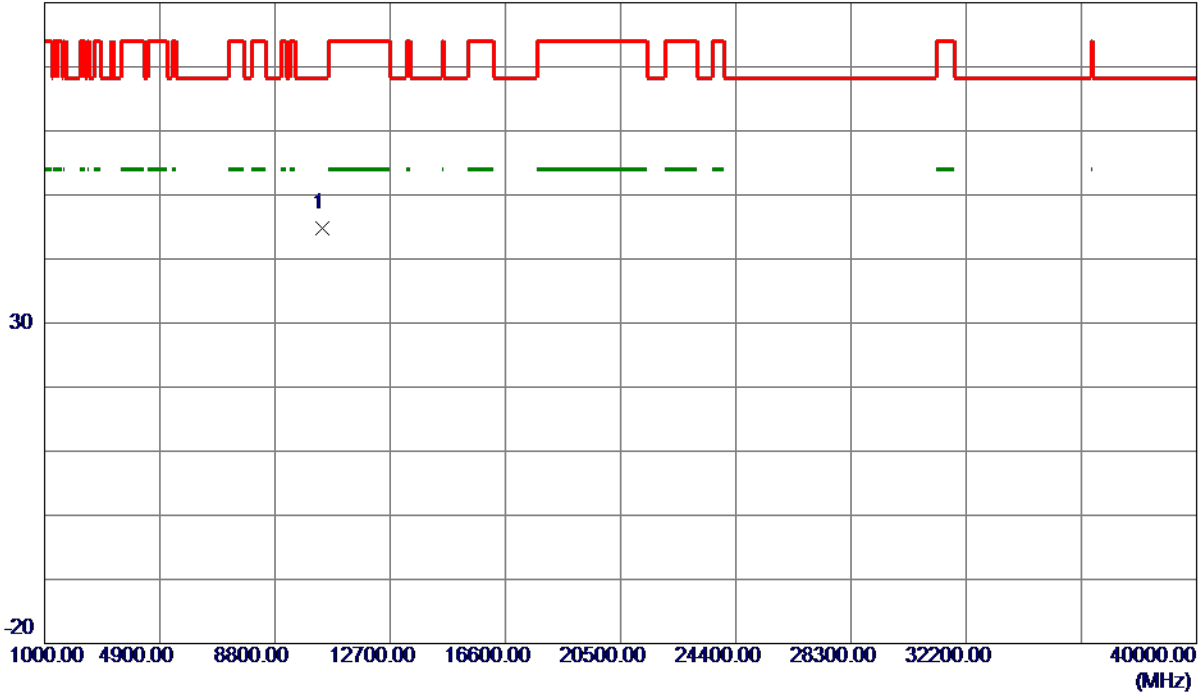

No.	Freq. MHz	Reading Level dBuV/m	Correct Factor dB	Measure ment dBuV/m	Limit dBuV/m	Margin dB	Detector	Comment
1 *	10417.2300	33.36	11.40	44.76	68.30	-23.54	Peak	

**REMARKS:**

- (1) Measurement Value = Reading Level + Correct Factor.
- (2) Margin Level = Measurement Value - Limit Value.



Orthogonal Axis	X
Test Mode	UNII-2A_TX AC (VHT20) Mode 5260 MHz

**Vertical**

130 dBuV/m

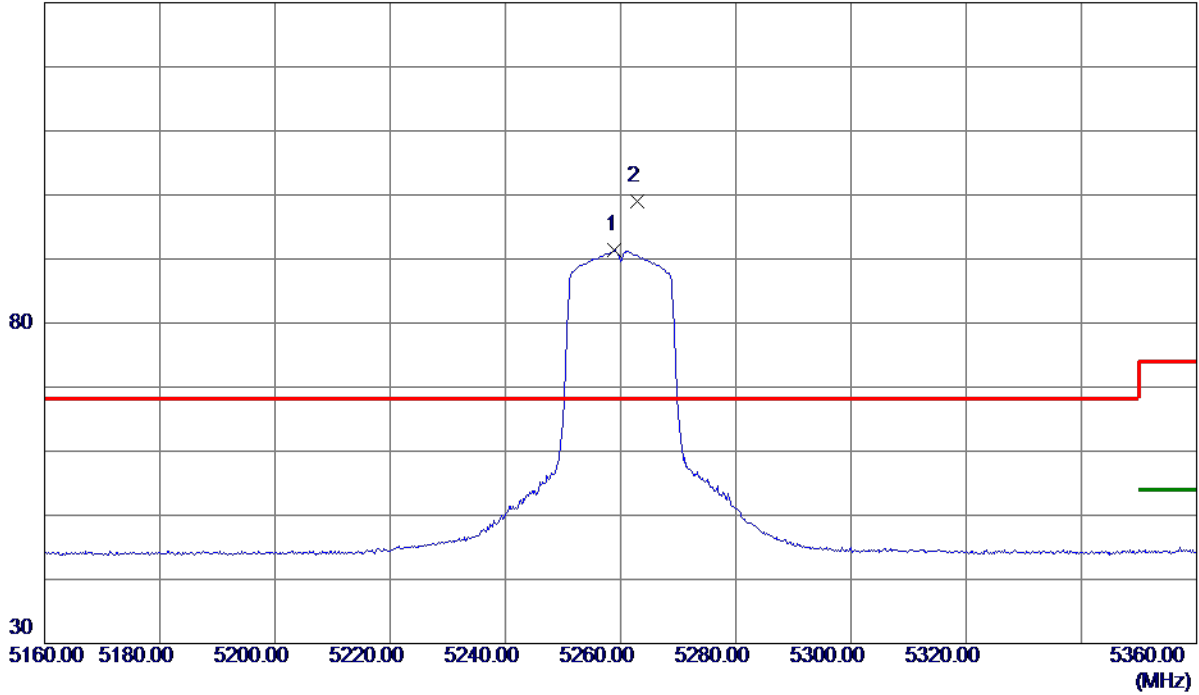

No.	Freq. MHz	Reading Level dBuV/m	Correct Factor dB	Measure ment dBuV/m	Limit dBuV/m	Margin dB	Detector	Comment
1	5259.0000	76.52	14.79	91.31	999.00	-907.69	AVG	No Limit
2 *	5262.8000	84.28	14.79	99.07	68.30	30.77	Peak	No Limit

**REMARKS:**

- (1) Measurement Value = Reading Level + Correct Factor.
- (2) Margin Level = Measurement Value - Limit Value.

Orthogonal Axis	X
Test Mode	UNII-2A_TX AC (VHT20) Mode 5260 MHz

**Vertical**

80 dBuV/m



No.	Freq. MHz	Reading Level dBuV/m	Correct Factor dB	Measure ment dBuV/m	Limit dBuV/m	Margin dB	Detector	Comment
1 *	10524.3450	33.20	11.54	44.74	68.30	-23.56	Peak	

**REMARKS:**

- (1) Measurement Value = Reading Level + Correct Factor.
- (2) Margin Level = Measurement Value - Limit Value.

Orthogonal Axis	X
Test Mode	UNII-2A_TX AC (VHT20) Mode 5260 MHz

### Horizontal

130 dBuV/m

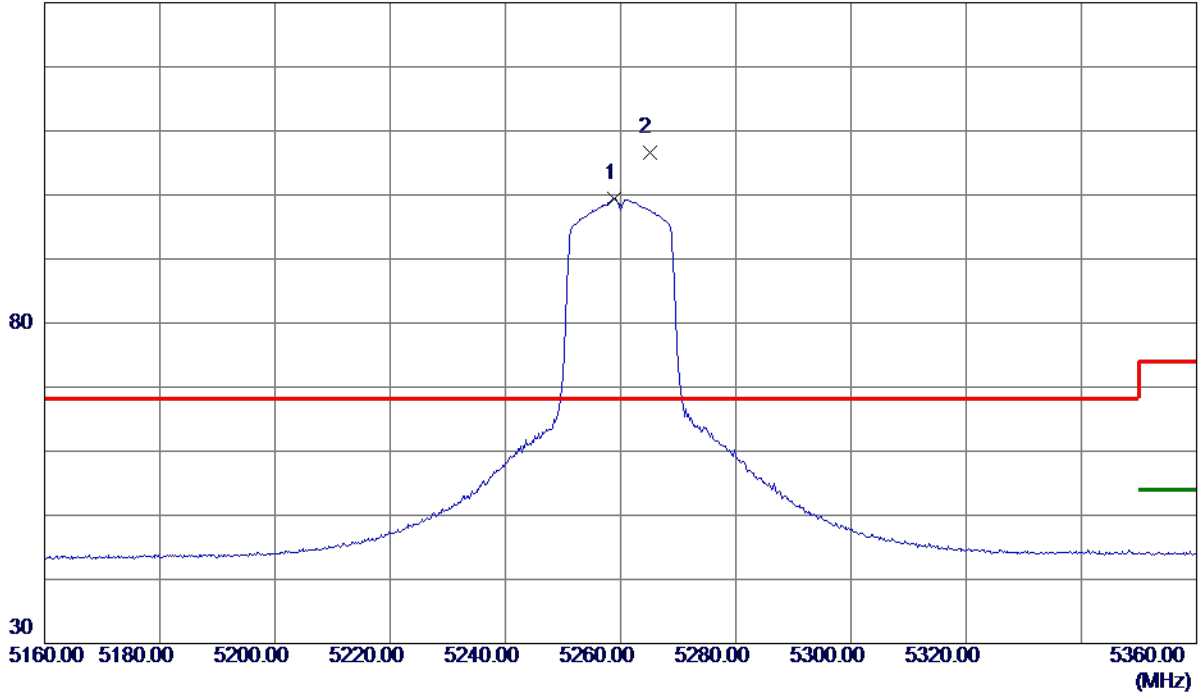

No.	Freq. MHz	Reading Level dBuV/m	Correct Factor dB	Measure ment dBuV/m	Limit dBuV/m	Margin dB	Detector	Comment
1	5258.8000	84.61	14.78	99.39	999.00	-899.61	AVG	No Limit
2 *	5265.0000	91.81	14.80	106.61	68.30	38.31	Peak	No Limit

**REMARKS:**

- (1) Measurement Value = Reading Level + Correct Factor.
- (2) Margin Level = Measurement Value - Limit Value.

Orthogonal Axis	X
Test Mode	UNII-2A_TX AC (VHT20) Mode 5260 MHz

### Horizontal

80 dBuV/m

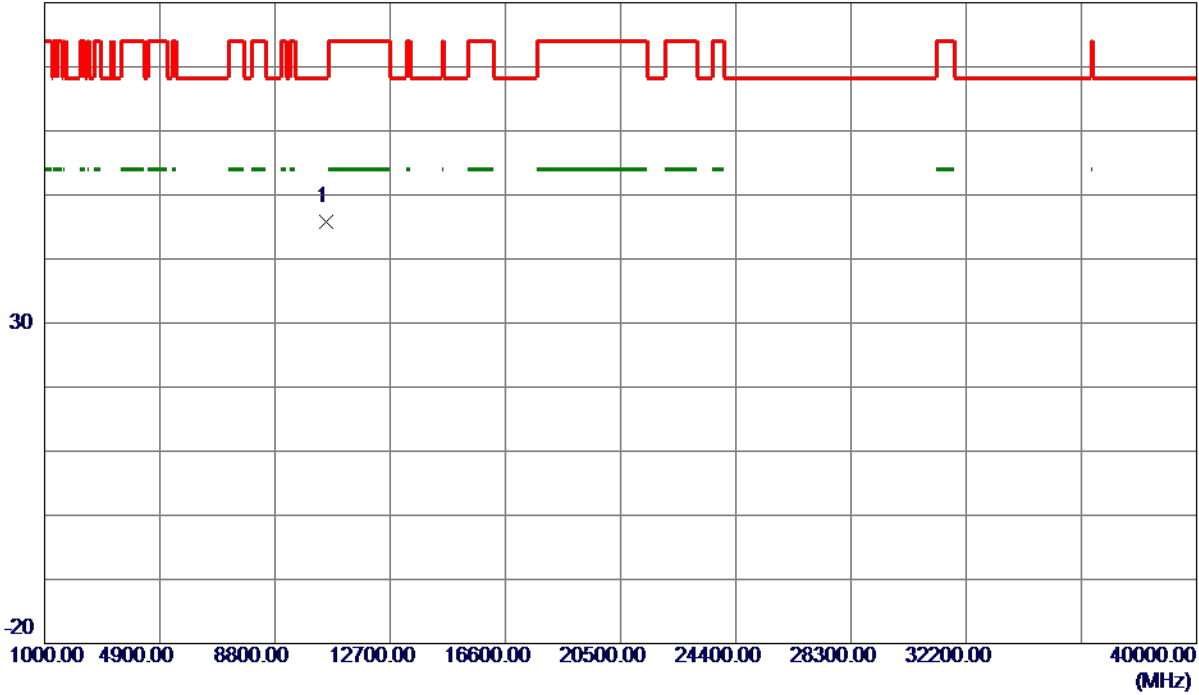

No.	Freq. MHz	Reading Level dBuV/m	Correct Factor dB	Measure ment dBuV/m	Limit dBuV/m	Margin dB	Detector	Comment
1 *	10523.3600	34.17	11.54	45.71	68.30	-22.59	Peak	

**REMARKS:**

- (1) Measurement Value = Reading Level + Correct Factor.
- (2) Margin Level = Measurement Value - Limit Value.

Orthogonal Axis	X
Test Mode	UNII-2A_TX AC (VHT20) Mode 5300 MHz

**Vertical**

130 dBuV/m

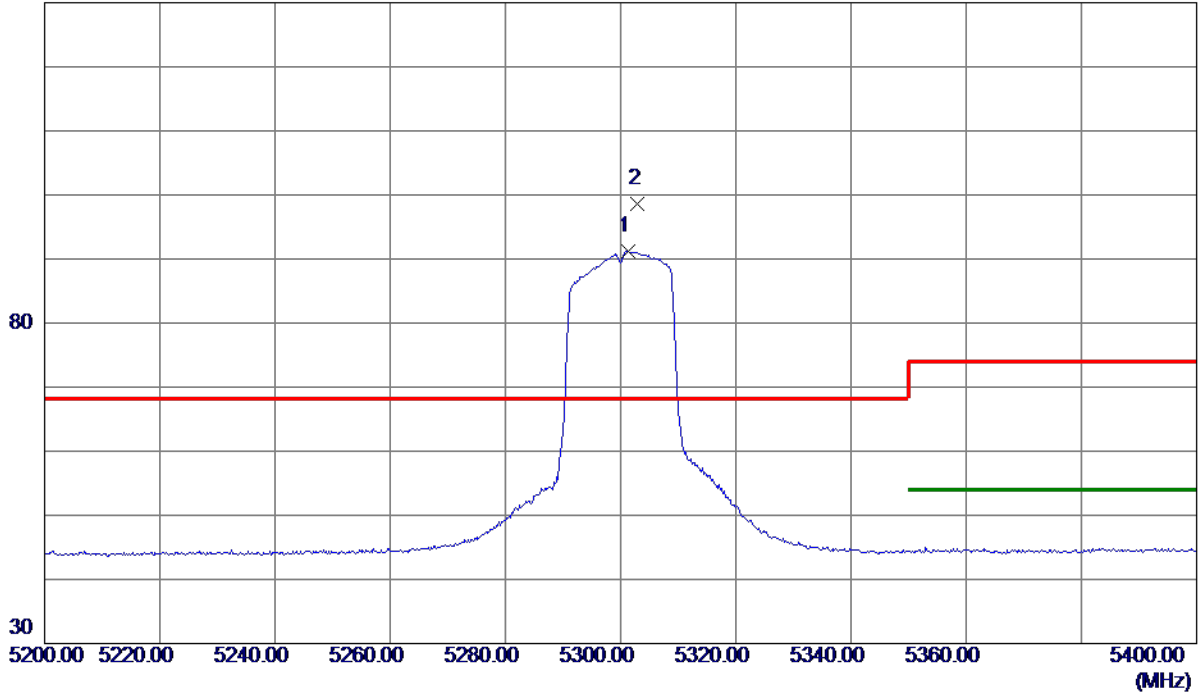

No.	Freq. MHz	Reading Level dBuV/m	Correct Factor dB	Measure ment dBuV/m	Limit dBuV/m	Margin dB	Detector	Comment
1	5301.4000	76.35	14.89	91.24	999.00	-907.76	AVG	No Limit
2 *	5303.0000	83.74	14.90	98.64	68.30	30.34	Peak	No Limit

**REMARKS:**

- (1) Measurement Value = Reading Level + Correct Factor.
- (2) Margin Level = Measurement Value - Limit Value.

Orthogonal Axis	X
Test Mode	UNII-2A_TX AC (VHT20) Mode 5300 MHz

**Vertical**

80 dBuV/m

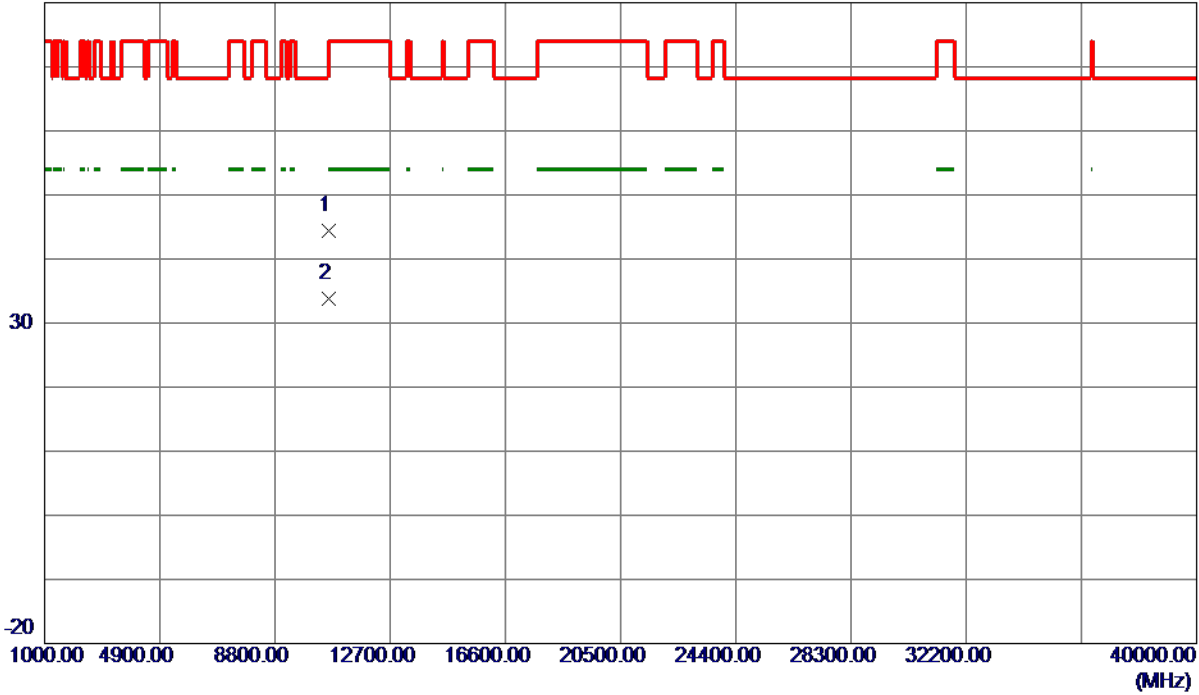

No.	Freq. MHz	Reading Level dBuV/m	Correct Factor dB	Measurement dBuV/m	Limit dBuV/m	Margin dB	Detector	Comment
1	10600.0700	32.90	11.55	44.45	74.00	-29.55	Peak	
2 *	10604.1350	22.19	11.55	33.74	54.00	-20.26	AVG	

**REMARKS:**

- (1) Measurement Value = Reading Level + Correct Factor.
- (2) Margin Level = Measurement Value - Limit Value.

Orthogonal Axis	X
Test Mode	UNII-2A_TX AC (VHT20) Mode 5300 MHz

### Horizontal

130 dBuV/m

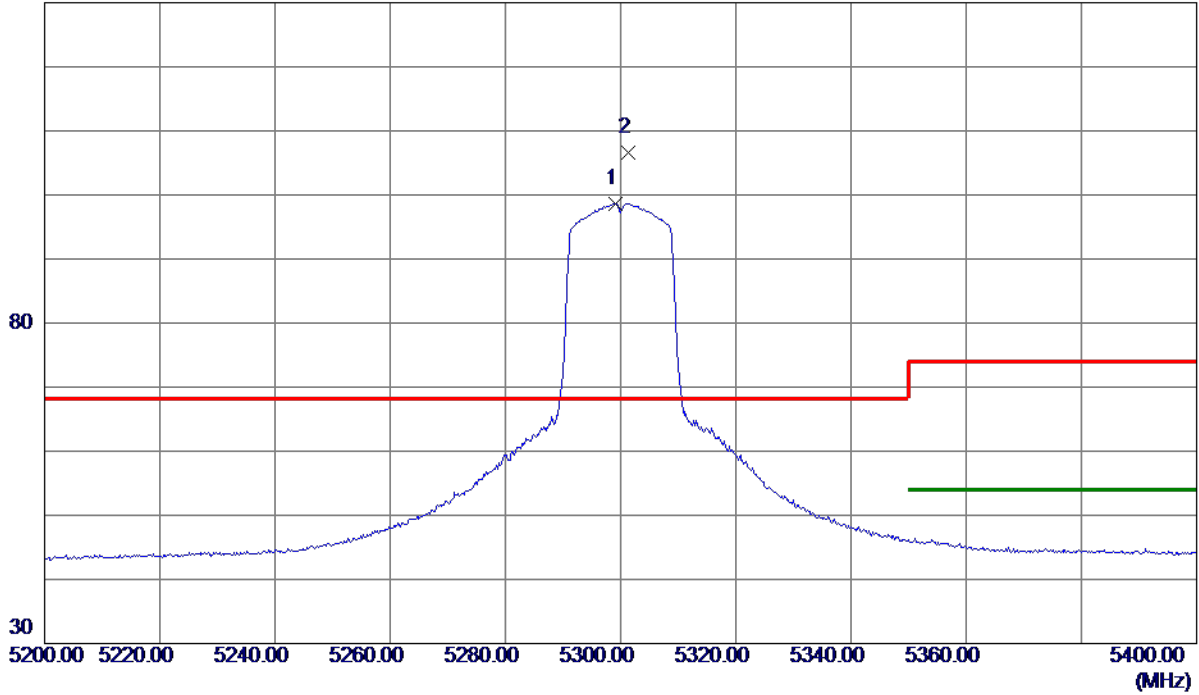

No.	Freq. MHz	Reading Level dBuV/m	Correct Factor dB	Measure ment dBuV/m	Limit dBuV/m	Margin dB	Detector	Comment
1	5299.2000	83.78	14.89	98.67	999.00	-900.33	AVG	No Limit
2 *	5301.4000	91.71	14.89	106.60	68.30	38.30	Peak	No Limit

**REMARKS:**

- (1) Measurement Value = Reading Level + Correct Factor.
- (2) Margin Level = Measurement Value - Limit Value.