

TRF6903 SINGLE-CHIP MULTIBAND RF TRANSCEIVER

SWRS022C – MARCH 2004 – REVISED JANUARY 2005

description

The TRF6903 single-chip solution is an integrated circuit intended for use as a low-cost multiband FSK or OOK transceiver to establish a frequency-programmable, half-duplex, bidirectional RF link. The multichannel transceiver is intended for digital (FSK, OOK) modulated applications in the North American and European 315-MHz, 433-MHz, 868-MHz, and 915-MHz ISM bands. The single-chip transceiver operates down to 2.2 V and is designed for low power consumption. The synthesizer has a typical channel spacing of better than 200 kHz and features a fully-integrated VCO. Only the PLL loop filter is external to the device.

Two fully-programmable operation modes, Mode0 and Mode1, allow extremely fast switching between two preprogrammed settings (for example, receive (RX)/transmit (TX); TX_frequency_0/TX_frequency_1; RX_frequency_0/RX_frequency_1; ...) without reprogramming the device.

ISM band standards

Europe has assigned an unlicensed frequency band of 868 MHz to 870 MHz. This band is specifically defined for short range devices with duty cycles from 0.1% to 100% in several subbands. The new European frequency band, due to the duty cycle assignment, allows a reliable RF link and makes many new applications possible.

The North American unlicensed ISM band covers 902 MHz to 928 MHz (center frequency of 915 MHz), and is suitable for short range RF links.

transmitter

The transmitter consists of an integrated VCO and tank circuit, a complete integer-N synthesizer, and a power amplifier. The dividers, prescaler, and reference oscillator require only the addition of an external crystal and a loop filter to provide a complete PLL with a typical frequency resolution of better than 200 kHz.

Since the typical RF output power is approximately 8 dBm, no additional external RF power amplifier is necessary in most applications.

Four attenuation settings for the power amplifier are offered. This feature allows the user to fine tune the amplifier for optimal output power.

receiver

The integrated receiver is intended to be used as a single-conversion FSK/OOK receiver. It consists of a low noise amplifier, mixer, limiter, FM/FSK demodulator with an external LC tank circuit or ceramic resonator, LPF amplifier, and a data slicer with clock recovery and an integrated data bit synchronizer. The received strength signal indicator (RSSI) can also be used for fast carrier sense on/off keying, or amplitude shift keying, (OOK/ASK) demodulator.

baseband interface

The TRF6903 can easily be interfaced to a baseband processor such as the Texas Instruments MSP430 ultralow-power microcontroller (see Figure 1). The TRF6903 serial control registers are programmed by the MSP430 and the MSP430 performs baseband operations in the software.

A synchronized data clock, programmable for most common data rates, is provided by the TRF6903. This feature reduces the need for extensive oversampling and data decision in the microcontroller during receive. During transmit, the data clock can be used to clock the transmit data from the microcontroller to the TRF6903 at predefined data rates.



POST OFFICE BOX 655303 • DALLAS, TEXAS 75265
POST OFFICE BOX 1443 • HOUSTON, TEXAS 77251-1443

TRF6903 SINGLE-CHIP MULTIBAND RF TRANSCEIVER

SWRS022C - MARCH 2004 - REVISED JANUARY 2005

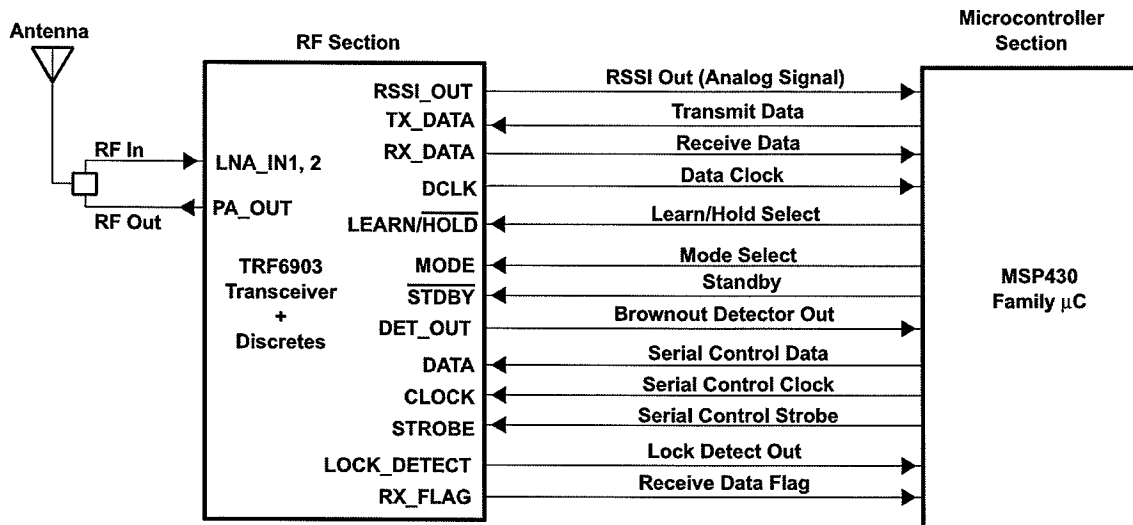

Figure 1. System Block Diagram for Interfacing to the MSP430 Microcontroller