

Report on the Testing of the
Landis + Gyr Technology, Inc.
T1501 Series-5 Mesh

In accordance with:
FCC 47 CFR part 15.249
ISED RSS-210 Issue 10, December 2019

Prepared for: Landis + Gyr Technology, Inc.
30000 Mill Creek Ave., Suite 100
Alpharetta, GA 30022



America

Add value.
Inspire trust.

COMMERCIAL-IN-CONFIDENCE

Document Number: AT72172744.2C0

SIGNATURE

NAME	JOB TITLE	RESPONSIBLE FOR	ISSUE DATE
Kirby Munroe	Wireless / EMC Technical and Certification Manager, NA TUV SUD America Inc.	Authorized Signatory	11/17/2021

Signatures in this approval box have checked this document in line with the requirements of TÜV SÜD America, Inc. document control rules.

FCC Accreditation Designation Number 967699
Innovation, Science, and Economic Development Canada Accreditation 23932

EXECUTIVE SUMMARY

A sample of this product was tested and found to be compliant with the standards listed above.



A2LA Cert. No. 2955.09

DISCLAIMER AND COPYRIGHT

This non-binding report has been prepared by TÜV SÜD America with all reasonable skill and care. The document is confidential to the potential Client and TÜV SÜD America. No part of this document may be reproduced without the prior written approval of TÜV SÜD America. © TÜV SÜD.

ACCREDITATION

Our A2LA Accreditation does not cover opinions and interpretations and any expressed are outside the scope of our A2LA Accreditation.

TÜV SÜD America
5945 Cabot Parkway, Suite 100
Alpharetta, GA 3005

Phone: 678-341-5900
www.tuv-sud-america.com



Contents

1	Report Summary	3
1.1	Report Modification Record.....	3
1.2	Introduction.....	3
1.3	Brief Summary of Results	5
1.4	Product Information	6
1.5	Deviations from the Standard.....	8
1.6	EUT Modification Record	9
1.7	Test Location	9
2	Test Details	10
2.1	Antenna Requirement	10
2.2	Power Line Conducted Emissions	11
2.3	20dB / 99% Bandwidth	13
2.4	Fundamental Field Strength.....	19
2.5	Radiated Spurious Emissions	21
2.6	Test Equipment Used.....	27
3	Diagram of Test Set-ups.....	28
4	Accreditation, Disclaimers and Copyright.....	30
	Appendix A: Test Setup Photos.....	Error! Bookmark not defined.



1 Report Summary

1.1 Report Modification Record

Alterations and additions to this report will be issued to the holders of each copy in the form of a complete document.

Table 1.1-1 – Modification Record

Issue	Description of Change	Date of Issue
0	First Issue	11/17/2021

1.2 Introduction

The purpose of this report is to demonstrate compliance with Part 15 Subpart C of the FCC's Code of Federal Regulations Section 15.249 and Innovation Science and Economic Development Canada's Radio Standards Specification RSS-210 for the tests documented herein.

Applicant	Tim Walters
Manufacturer	Landis + Gyr Technology, Inc
Applicant's Email Address	Tim.walters@landisgyr.com
Model Number(s)	T1501 Series-5 Mesh
Serial Number(s)	LAN ID: 9160F62C (Conducted and Field strength measurement) LAN ID: 9160F63C (Radiated measurement)
FCC ID	R7PNG0R1S5LP
ISED Certification Number	5294A-NG0R1S5LP
Hardware Version(s)	N/A
Software Version(s)	N/A
Number of Samples Tested	1
Test Specification/Issue/Date	US Code of Federal Regulation (CFR): Title 47, Part 15, Subpart C: Radio Frequency Devices, Intentional Radiators, 2021 Innovation, Science and Economic Development Canada Radio Standards Specification: RSS-210 – License-Exempt Radio Apparatus: Category I Equipment, Issue 10, December 2019
Order Number	72172746
Date of Receipt of EUT	2021-October-11
Start of Test	2021-October-13
Finish of Test	2021-October-15



Related Document(s)

ANSI C63.10-2013: American National Standard of Procedures for Compliance Testing of Unlicensed Wireless Device.

US Code of Federal Regulations (CFR): Title 47, Part 2, Subpart J: Equipment Authorization Procedures, 2021.

ISED Canada Radio Standards Specification: RSS-GEN – General Requirements for Compliance of Radio Apparatus, Issue 5, Amendment 1 (March 2019), Amendment 2 (February 2021)

1.3 Brief Summary of Results

A brief summary of the tests carried out in accordance with FCC Part 15.249 and ISED Canada's RSS-210 is shown below.

Table 1.3-1: Test Result Summary

Test Parameter	Test Plan (Yes/No)	Test Result	FCC 47 CFR Rule Part	ISED Canada's RSS	Test Report Page No
Antenna Requirement	Yes	Pass	15.203	-----	10
Power Line Conducted Emissions	Yes	Pass	15.207	RSS-GEN 8.8	11
20 dB Bandwidth	Yes	Pass	15.215(c)	RSS-GEN 6.7	13
99% Bandwidth	Yes	Pass	-----	RSS-GEN 6.7	13
Fundamental Field Strength	Yes	Pass	15.249(a)	RSS-210 B.10	19
Radiated Spurious Emissions	Yes	Pass	15.249(a)(d)(e)	RSS-210 B.10	21

1.4 Product Information

1.4.1 Technical Description

The Series-5 RF proprietary protocol supports baud rates up to 115.2 kbps. operation in the Sub-GHz band. There are 2 types of RF proprietary protocol radios with Mesh wide band and narrow band modes.

Table 1.4-1 – Wireless Technical Information

Detail	Description
FCC ID	R7PNG0R1S5LP
ISED ID	5294A-NG0R1S5LP
Transceiver Model #	T1501 Series-5 Mesh
Modulation Format	Proprietary FSK
Antenna Type / Description:	Monopole chip antenna / 1dBi Gain

A full description and detailed product specification details are available from the manufacturer.



Photo 1.4.1-1 –Front view of the EUT



Photo 1.4.1-2 – Back view of the EUT

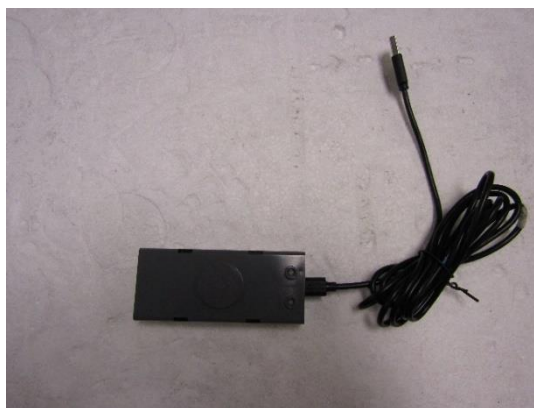

Photo 1.4.1-3 –EUT with USB cable

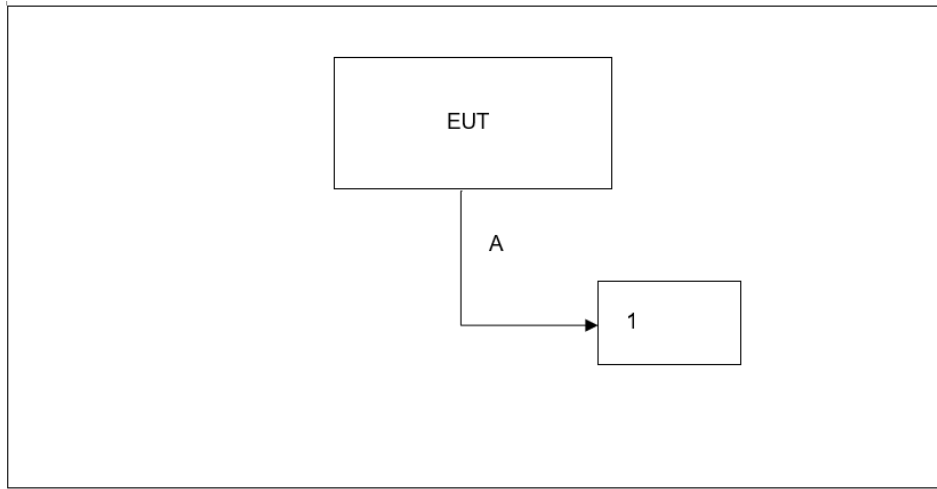

Figure 1.4.1-4 – Test Setup Block Diagram

Table 1.4.1-1 – Cable Descriptions

Item	Cable/Port	Description
A	USB	Power Cable

Table 1.4.1-2 – Support Equipment Descriptions

Item	Make/Model	Description
1	Lenovo	Laptop used for configuring wireless module – Landis + Gyr provided

1.4.2 Modes of Operation

T1501 Series-5 Mesh model provides 2 distinct proprietary modes of operation using DXT (Low Power mode) classifications as outlined below.

Mode of Operation	Frequency Range (MHz)	Number of Channels	Channel Separation (kHz)	Stack / Mode	Data Rates Supported (kbps)	Classification
1	902.3 - 927.8	86	300	Mesh (Wide band) FSK Low Power	9.6, 19.2, 38.4, 115.2	DXT
2	904.0 - 927.8	239	100	Mesh (Narrow band) FSK Low Power	9.6, 19.2, 38.4	DXT

1.4.3 Monitoring of Performance

For radiated emissions, the EUT was evaluated in three orthogonal orientations. The worst-case orientation was X-position. See test setup photos for more information. The EUT was programmed to generate a continuously modulated signal on each channel evaluated.

For RF Conducted measurements, the EUT was connected to the test equipment with a MMCX to SMA connector.

Worst case mode for all other parameters measured listed below:

Mode	Classification	20dB / 99% Bandwidth	Fundamental Field Strength	Radiated Spurious Emissions
		Data Rate (kbps)		
1	DXT	9.6, 19.2, 38.4, 115.2	9.6	9.6
2	DXT	*	9.6	*

* Addressed by mode 1

Power setting during test: Mode of operation 1 & 2: -10 dBm

1.5 Deviations from the Standard

No deviations from the applicable test standard were made during testing.

1.6 EUT Modification Record

The table below details modifications made to the EUT during the test program. The modifications incorporated during each test are recorded on the appropriate test pages.

Modification State	Description of Modification still fitted to EUT	Modification Fitted By	Date Modification Fitted
0	Initial State		

The equipment was tested as provided without any modifications.

1.7 Test Location

TÜV SÜD conducted the following tests at our Alpharetta, GA test laboratory.

Test Name	Name of Engineer(s)	Accreditation
Antenna Requirement	Divya Adusumilli	A2LA
Power Line Conducted Emissions	Divya Adusumilli	A2LA
20dB / 99% Bandwidth	Divya Adusumilli	A2LA
Fundamental Field Strength	Divya Adusumilli	A2LA
Radiated Spurious Emissions	Bhagyashree Chaudhary	A2LA

Office address:
TÜV SÜD America
5945 Cabot Parkway, Suite 100
Alpharetta, GA 30005, USA

2 Test Details

2.1 Antenna Requirement

2.1.1 Specification Reference

FCC Section: 15.203

2.1.2 Equipment Under Test and Modification State

As shown in §1.4 with modification state "0", as noted in §1.6.

2.1.3 Date of Test

10/13/2021

2.1.4 Test Method

N/A

2.1.5 Environmental Conditions

The EUT was evaluated within the temperature, humidity and pressure range of the EUT as specified by the standard. The laboratory shall have an ambient temperature range of 15°C to 35°C, relative humidity range of 30% to 60% and atmospheric pressure range of 86 kPa to 106 kPa.

Ambient Temperature	22.3 °C
Relative Humidity	53.8 %
Atmospheric Pressure	972.2 mbar

2.1.6 Test Results

The EUT utilizes monopole chip antenna with peak gain 1 dBi which is mounted on the bottom side of the printed circuit board, therefore satisfying the requirements of Section 15.203.

2.2 Power Line Conducted Emissions

2.2.1 Specification Reference

FCC Section: 15.207
ISED Canada: RSS-Gen 8.8

2.2.2 Equipment Under Test and Modification State

As shown in §1.4 with modification state “0”, as noted in §1.6.

2.2.3 Date of Test

10/14/2021

2.2.4 Test Method

ANSI C63.10 section 6 was the guiding documents for this evaluation. Conducted emissions were performed from 150kHz to 30MHz with the spectrum analyzer’s resolution bandwidth set to 9kHz and the video bandwidth set to 30kHz. The calculation for the conducted emissions is as follows:

$$\text{Corrected Reading} = \text{Analyzer Reading} + \text{LISN Loss} + \text{Cable Loss}$$
$$\text{Margin} = \text{Corrected Reading} - \text{Applicable Limit}$$

2.2.5 Environmental Conditions

The EUT was evaluated within the temperature, humidity and pressure range of the EUT as specified by the standard. The laboratory shall have an ambient temperature range of 15°C to 35°C, relative humidity range of 30% to 60% and atmospheric pressure range of 86 kPa to 106 kPa.

Ambient Temperature 22.3 °C
Relative Humidity 53.8 %
Atmospheric Pressure 972.2 mbar

2.2.6 Test Results

Table 2.2.6-1: Conducted EMI Results-Avg – Line 1

Frequency (MHz)	Avg Limit	Avg Level Corrected	Avg Level	Correction Fact.	Avg Margin	Result
0.15	56	42.3	32.6	9.682	-13.7	PASS
0.8	46	22.3	12.6	9.668	-23.7	PASS
1.6	46	23.4	13.7	9.662	-22.6	PASS
1.64	46	22.2	12.6	9.663	-23.8	PASS
1.68	46	23.2	13.5	9.664	-22.8	PASS
2.47	46	22.8	13.1	9.689	-23.2	PASS

Table 2.2.6-2: Conducted EMI Results-QP – Line 1

Frequency (MHz)	QP Limit	QP Level Corrected	QP Level	Correction Fact.	QP Margin	Result
0.15	66	50.7	41.1	9.682	-15.3	PASS
0.8	56	29.5	19.8	9.668	-26.5	PASS
1.6	56	29.5	19.8	9.662	-26.5	PASS
1.64	56	29.3	19.6	9.663	-26.7	PASS
1.68	56	29.4	19.8	9.664	-26.6	PASS
2.47	56	29.1	19.4	9.689	-26.9	PASS

Table 2.2.6-3: Conducted EMI Results-Avg – Line 2

Frequency (MHz)	Avg Limit	Avg Level Corrected	Avg Level	Correction Fact.	Avg Margin	Result
0.15	56	40.5	30.8	9.675	-15.5	PASS
0.5	46.1	26.4	16.7	9.631	-19.8	PASS
1.34	46	20.2	10.5	9.667	-25.8	PASS
1.52	46	21.8	12.1	9.67	-24.2	PASS
1.96	46	21.8	12.1	9.661	-24.2	PASS
3.13	46	21.7	12	9.693	-24.3	PASS

Table 2.2.6-4: Conducted EMI Results-QP – Line 2

Frequency (MHz)	QP Limit	QP Level Corrected	QP Level	Correction Fact.	QP Margin	Result
0.15	66	49.2	39.5	9.675	-16.8	PASS
0.5	56.1	29.1	19.4	9.631	-27.1	PASS
1.34	56	25.5	15.9	9.667	-30.5	PASS
1.52	56	26.4	16.7	9.67	-29.6	PASS
1.96	56	26.2	16.5	9.661	-29.8	PASS
3.13	56	25.7	16	9.693	-30.3	PASS

2.3 20dB / 99% Bandwidth

2.3.1 Specification Reference

FCC Sections: 15.215(c)
ISED Canada: RSS-GEN 6.7

2.3.2 Equipment Under Test and Modification State

As shown in §1.4 with modification state "0", as noted in §1.6.

2.3.3 Date of Test

10/13/2021

2.3.4 Test Method

The RF output port of the EUT was directly connected to the input of the spectrum analyzer with suitable attenuation. The span of the spectrum analyzer display was set between two times and five times the occupied bandwidth (OBW) of the emission. The RBW of the spectrum analyzer was set to approximately 1 % to 5 % of the OBW. The trace was set to max hold with a peak detector active. The Delta and ndB down functions of the analyzer were utilized to determine the 20 dB bandwidth of the emission.

The occupied bandwidth measurement function of the spectrum analyzer was used to measure the 99% bandwidth. The span of the analyzer was set to capture all products of the modulation process, including the emission sidebands. The resolution bandwidth was set to 1% to 5% of the occupied bandwidth. The video bandwidth was set to 3 times the resolution bandwidth. A peak detector was used.

2.3.5 Environmental Conditions

The EUT was evaluated within the temperature, humidity and pressure range of the EUT as specified by the standard. The laboratory shall have an ambient temperature range of 15°C to 35°C, relative humidity range of 30% to 60% and atmospheric pressure range of 86 kPa to 106 kPa.

Ambient Temperature	22.3 °C
Relative Humidity	53.8 %
Atmospheric Pressure	972.2 mbar

2.3.6 Test Results

Test Summary: EUT was set to transmit mode.

Test Results: Pass

See data below for detailed results.

Table 2.3.6-1: 20dB / 99% Bandwidth

Frequency [MHz]	20dB Bandwidth (kHz)	99% Bandwidth (kHz)	Data Rate (kbps)	Mode(s)
902.3	21.371	20.866	9.6	1
902.3	41.864	43.489	19.2	1
902.3	84.829	88.940	38.4	1
902.3	235.389	227.418	115.2	1
915.2	21.577	20.895	9.6	1
915.2	41.851	45.120	19.2	1
915.2	86.035	91.785	38.4	1
915.2	235.085	226.592	115.2	
927.8	21.609	20.946	9.6	1
927.8	41.445	45.186	19.2	1
927.8	86.054	94.972	38.4	1
927.8	235.514	227.218	115.2	1

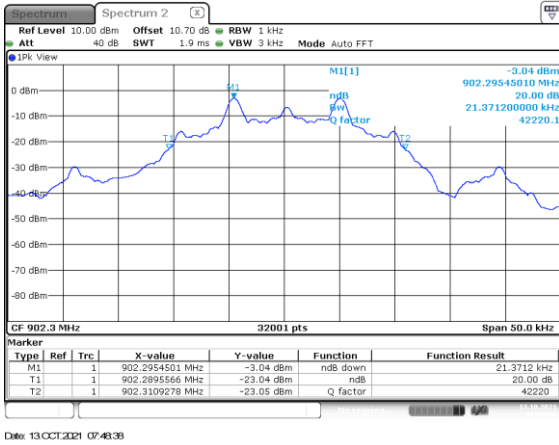

Date: 13.OCT.2021 07:43:38

Figure 2.3.6-1: 20dB BW Low Channel – 9.6 kbps

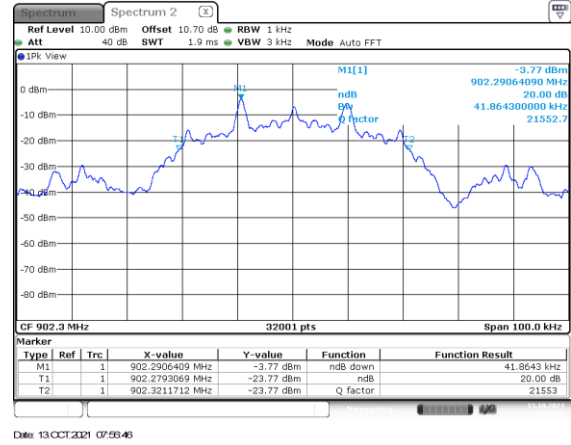

Date: 13.OCT.2021 07:55:45

Figure 2.3.6-2: 20dB BW Low Channel – 19.2 kbps

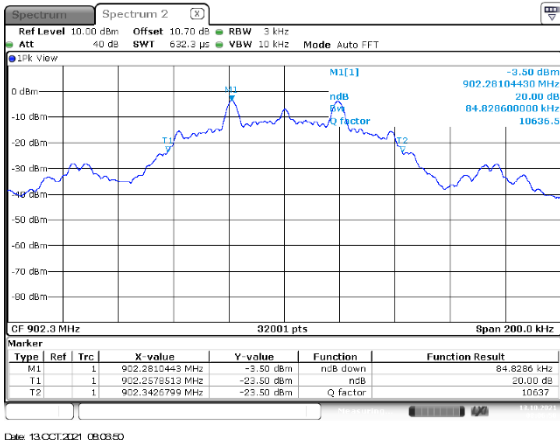

Date: 13.OCT.2021 08:03:50

Figure 2.3.6-3: 20dB BW Low Channel – 38.4 kbps



Date: 13.OCT.2021 08:47:47

Figure 2.3.6-4: 20dB BW Low Channel – 115.2 kbps

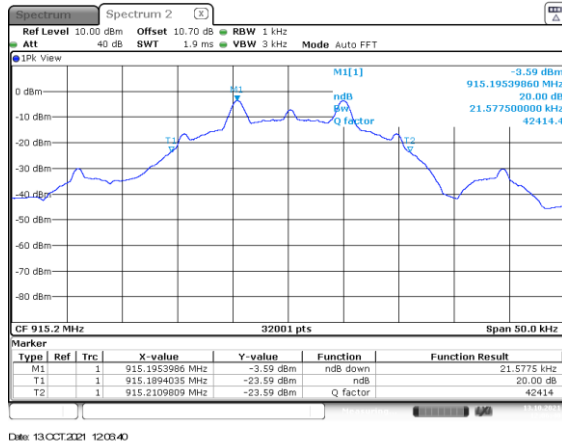

Figure 2.3.6-5: 20dB BW Mid Channel – 9.6 kbps

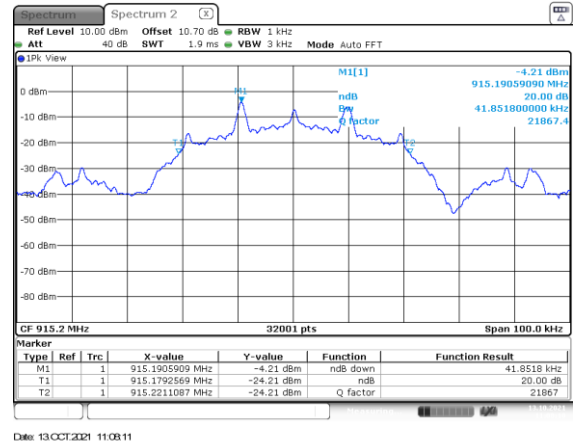

Figure 2.3.6-6: 20dB BW Mid Channel – 19.2 kbps

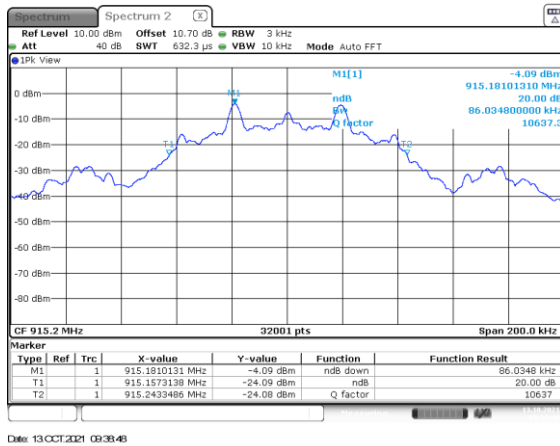

Figure 2.3.6-7: 20dB BW Mid Channel – 38.4 kbps

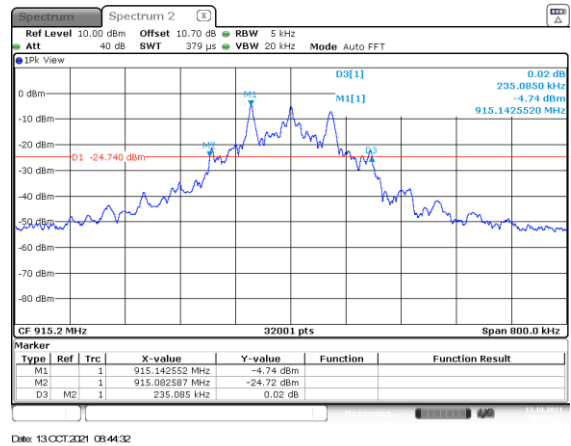

Figure 2.3.6-8: 20dB BW Mid Channel – 115.2 kbps

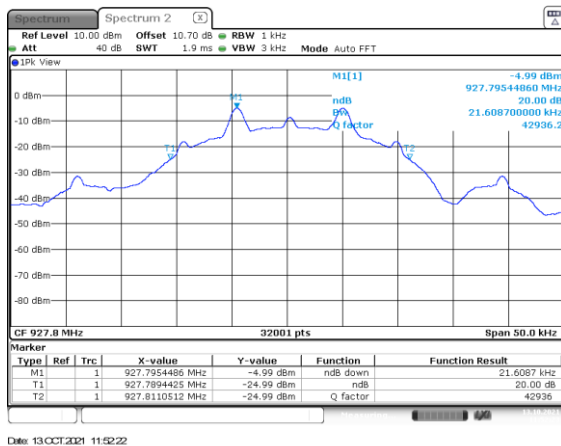

Figure 2.3.6-9: 20dB BW High Channel – 9.6 kbps

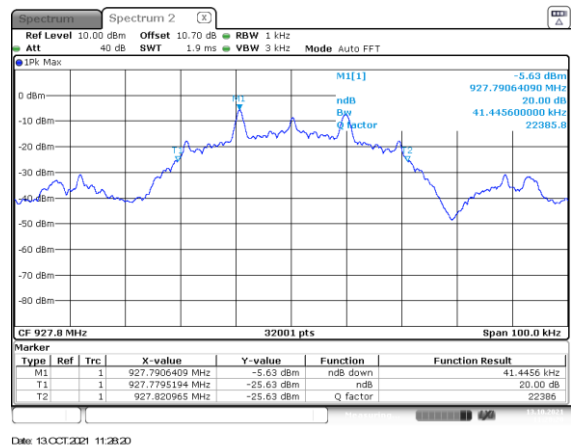

Figure 2.3.6-10: 20dB BW High Channel – 19.2 kbps

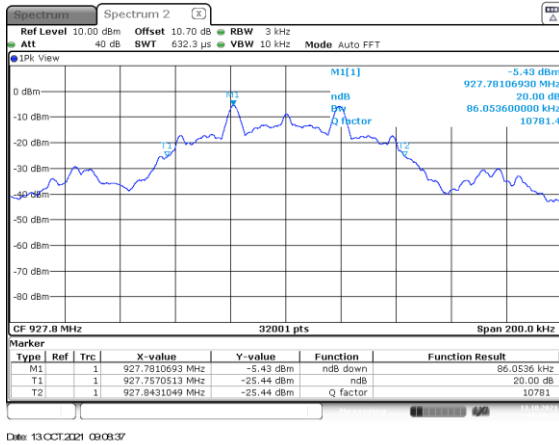

Figure 2.3.6-11: 20dB BW High Channel – 38.4 kbps

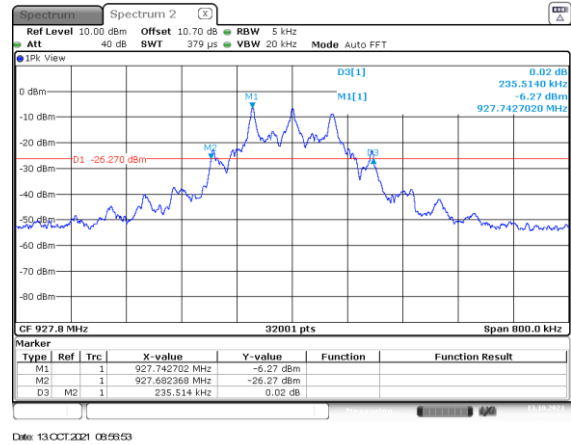

Figure 2.3.6-12: 20dB BW High Channel – 115.2 kbps

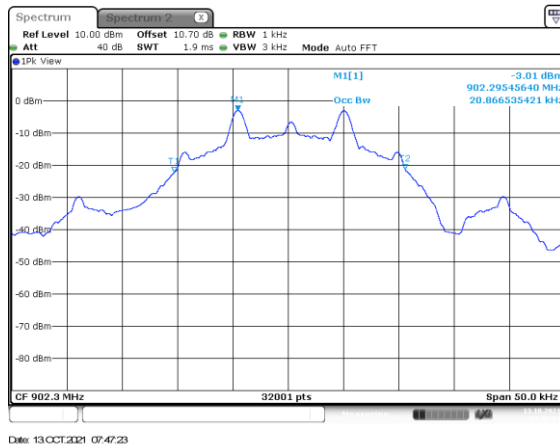

Figure 2.3.6-13: 99% BW Low Channel – 9.6 kbps

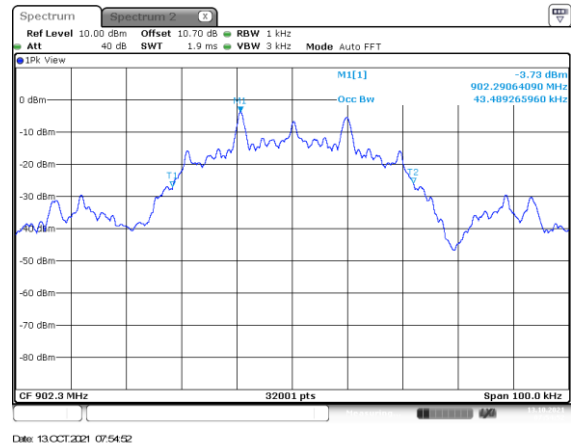

Figure 2.3.6-14: 99% BW Low Channel – 19.2 kbps

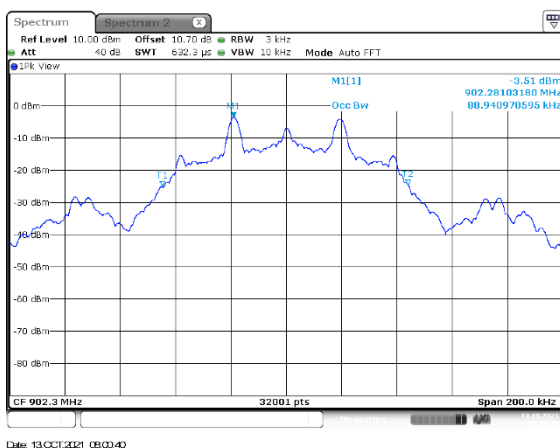

Figure 2.3.6-15: 99% BW Low Channel – 38.4 kbps

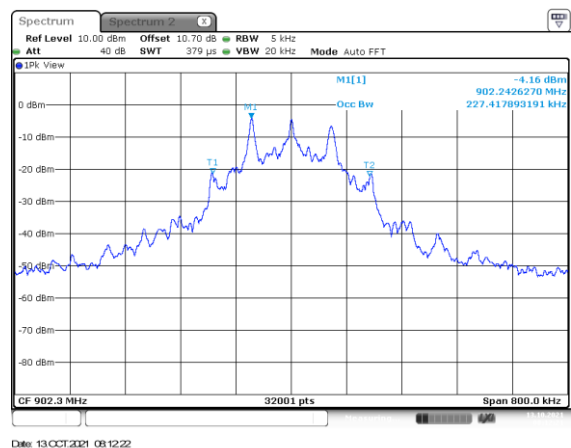

Figure 2.3.6-16: 99% BW Low Channel – 115.2 kbps

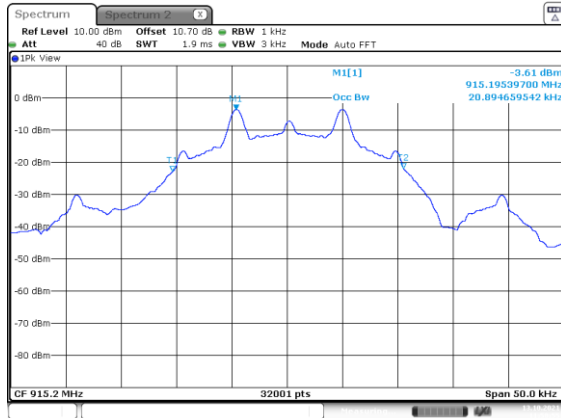

Figure 2.3.6-17: 99% BW Mid Channel – 9.6 kbps

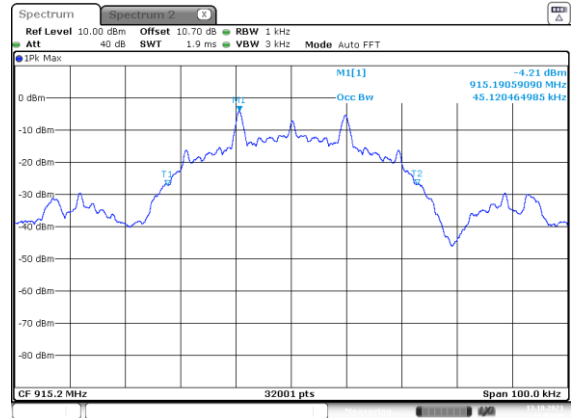

Figure 2.3.6-18: 99% BW Mid Channel – 19.2 kbps

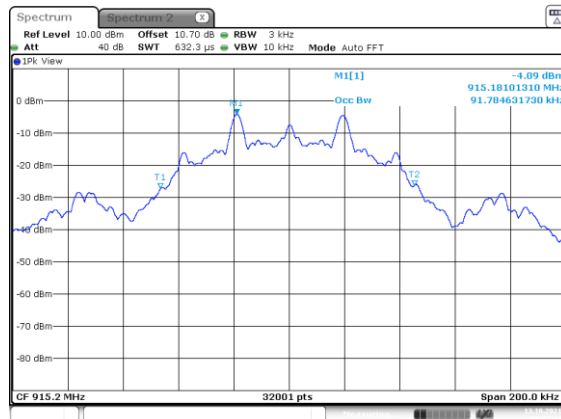

Figure 2.3.6-19: 99% BW Mid Channel – 38.4 kbps

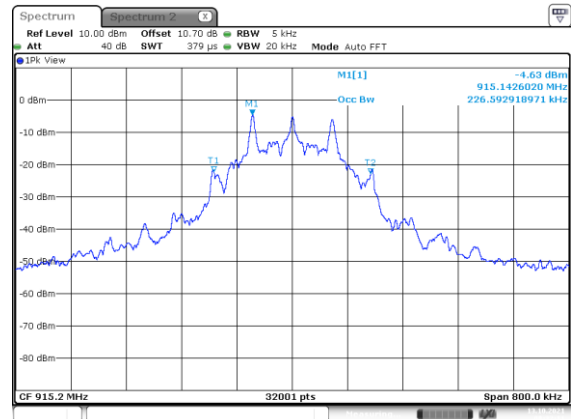

Figure 2.3.6-20: 99% BW Mid Channel – 115.2 kbps



Figure 2.3.6-21: 99% BW High Channel – 9.6 kbps

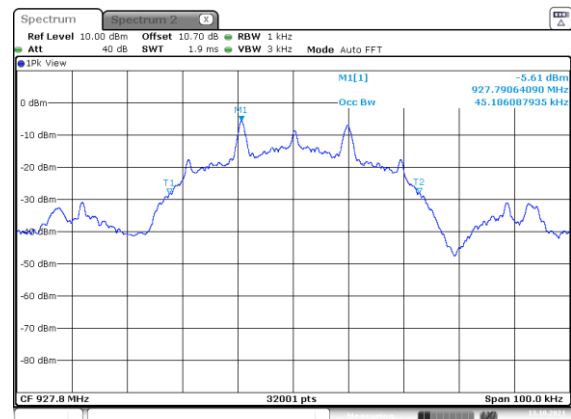

Figure 2.3.6-22: 99% BW High Channel – 19.2 kbps

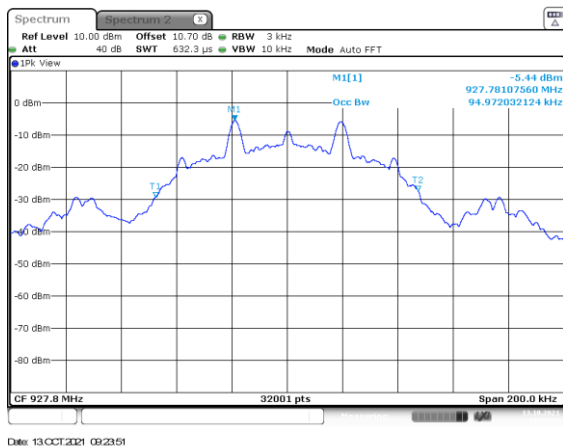

Figure 2.3.6-23: 99% BW High Channel – 38.4 kbps

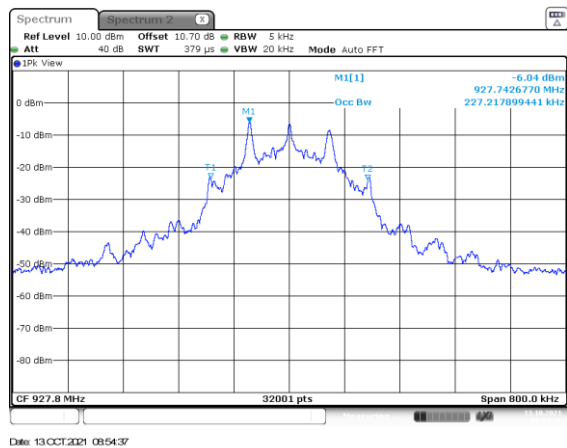

Figure 2.3.6-24: 99% BW High Channel – 115.2 kbps

2.4 Fundamental Field Strength

2.4.1 Specification Reference

FCC Sections: 15.249(a)(d)(e).
ISED Canada RSS – 210 B.10

2.4.2 Equipment Under Test and Modification State

As shown in §1.4 with modification state “0”, as noted in §1.6.

2.4.3 Date of Test

10/14/2021 to 10/19/2021

2.4.4 Test Method

The EUT was rotated through 360° and the receive antenna height was varied from 1m to 4m so that the maximum radiated emissions level would be detected. Quasi-peak measurements were made with RBW and VBW of 100 kHz and 300 kHz respectively.

2.4.5 Environmental Conditions

The EUT was evaluated within the temperature, humidity and pressure range of the EUT as specified by the standard. The laboratory shall have an ambient temperature range of 15°C to 35°C, relative humidity range of 30% to 60% and atmospheric pressure range of 86 kPa to 106 kPa.

Ambient Temperature	22.3 °C
Relative Humidity	53.8 %
Atmospheric Pressure	972.2 mbar

2.4.6 Test Results

Test Summary: EUT was set to transmit mode.

Test Results: Pass

See data below for detailed results.

Table 2.4.6-1: Fundamental Field Strength – Mode 1

Frequency (MHz)	Level (dBuV)		Antenna Polarity (H/V)	Correction Factors (dB)	Corrected Level (dBuV/m)		Limit (dBuV/m)		Margin (dB)	
	pk	Qpk/Avg			pk	Qpk/Avg	pk	Qpk/Avg	pk	Qpk/Avg
902.30	-----	89.40	H	2.35	-----	91.75	-----	94.0	-----	2.2
902.30	-----	85.80	V	2.35	-----	88.15	-----	94.0	-----	5.8
915.20	-----	88.60	H	2.15	-----	90.75	-----	94.0	-----	3.2
915.20	-----	85.90	V	2.15	-----	88.05	-----	94.0	-----	5.9
927.80	-----	86.60	H	2.41	-----	89.01	-----	94.0	-----	5.0
927.80	-----	85.20	V	2.41	-----	87.61	-----	94.0	-----	6.4

Table 2.4.6-1: Fundamental Field Strength – Mode 2

Frequency (MHz)	Level (dBuV)		Antenna Polarity (H/V)	Correction Factors (dB)	Corrected Level (dBuV/m)		Limit (dBuV/m)		Margin (dB)	
	pk	Qpk/Avg			pk	Qpk/Avg	pk	Qpk/Avg	pk	Qpk/Avg
904.00	-----	90.50	H	2.32	-----	92.82	-----	94.0	-----	1.2
904.00	-----	87.90	V	2.32	-----	90.22	-----	94.0	-----	3.8
915.00	-----	91.50	H	2.15	-----	93.65	-----	94.0	-----	0.3
915.00	-----	85.70	V	2.15	-----	87.85	-----	94.0	-----	6.1
927.80	-----	89.60	H	2.41	-----	92.01	-----	94.0	-----	2.0
927.80	-----	85.60	V	2.41	-----	88.01	-----	94.0	-----	6.0

2.5 Radiated Spurious Emissions

2.5.1 Specification Reference

FCC Sections: 15.249(d).
ISED Canada RSS – 210 B.10

2.5.2 Equipment Under Test and Modification State

As shown in §1.4 with modification state “0”, as noted in §1.6.

2.5.3 Date of Test

10/13/2021 to 10/15/2021

2.5.4 Test Method

Section 15.33(a)(4) specifies, if the intentional radiator contains a digital device, regardless of whether this digital device controls the functions of the intentional radiator or the digital device is used for additional control or function purposes other than to enable the operation of the intentional radiator, the frequency range shall be investigated up to frequency specified in 15.33(b)(1) for unintentional radiators. The upper frequency range for the digital device is 10GHz which greater than the 10th harmonic of the fundamental frequency. The upper frequency range measured was 10GHz.

Measurements below 30MHz were performed in a semi-anechoic chamber with a 3meter separation distance between the EUT and measurement antenna. The EUT was rotated 360° and the loop antenna rotated through three orthogonal axes. The magnetic loop receiving antenna was positioned with its lowest point 1 meter above the ground.

The spectrum analyzer's resolution and video bandwidth were set to 200 Hz and 1 kHz respectively for frequencies below 150 kHz and 9 kHz and 30 kHz respectively for frequencies above 150 kHz and below 30 MHz. For measurements in the frequency bands 9-90 kHz and 110-490 kHz, a peak detector was used. When average measurements are specified, the peak emissions were also compared to a limit corresponding to 20 dB above the maximum permitted average limit according to Part 15.35. All other emissions were measured using a peak detector.

Measurements above 30 MHz were performed in a semi-anechoic chamber with a 3meter separation distance between the EUT and measurement antenna. The EUT was rotated through 360° and the receive antenna height was varied from 1m to 4m so that the maximum radiated emissions level would be detected. For frequencies below 1000 MHz, quasi-peak measurements were made using a resolution bandwidth (RBW) of 120 kHz and a video bandwidth (VBW) of 300 kHz. For frequencies above 1000 MHz, peak and average measurements were made using a resolution bandwidth (RBW) of 1 MHz and a video bandwidth (VBW) of 3 MHz.

For measurements of fundamental emissions where average measurements are specified, the spectrum analyzer's resolution bandwidth (RBW) was adjusted equal to or greater than the emission bandwidth (EBW).

Distance Correction for Measurements Below 30 MHz – Part 15.31

Radiated measurements were performed at a distance closer than 300 meters and 30m as required, according to Part 15. 209. Therefore a correction factor was applied to account for propagation loss at the specified distance. The propagation loss was determined by using the square of an inverse linear distance extrapolation factor (40dB/decade) according to 15.31. A sample calculation of the distance correction factor is shown below for limits expressed at a 300m measurement distance and a 30m measurement distance.

$$\begin{aligned} \text{Distance correction factor (300m Specified Test Distance)} &= 40 \cdot \text{Log} (\text{Test Distance}/300) \\ &= 40 \cdot \text{Log} (3/300) \\ &= - 80 \text{ dB} \end{aligned}$$

$$\begin{aligned} \text{Distance correction factor (30m Specified Test Distance)} &= 40 \cdot \text{Log} (\text{Test Distance}/30) \\ &= 40 \cdot \text{Log} (3/30) \\ &= - 40 \text{ dB} \end{aligned}$$

2.5.5 Environmental Conditions

The EUT was evaluated within the temperature, humidity and pressure range of the EUT as specified by the standard. The laboratory shall have an ambient temperature range of 15°C to 35°C, relative humidity range of 30% to 60% and atmospheric pressure range of 86 kPa to 106 kPa.

Ambient Temperature	22.3 °C
Relative Humidity	53.8 %
Atmospheric Pressure	972.2 mbar

2.5.6 Test Results

Test Summary: EUT was set to transmit mode.

Test Results: Pass

See data below for detailed results.

Table 2.5.6-1: Radiated Spurious Emissions Tabulated Data – Mode 1

Frequency (MHz)	Level (dBuV)		Antenna Polarity (H/V)	Antenna Height (cm)	Turntable Position (o)	Correction Factors (dB)	Corrected Level (dBuV/m)		Limit (dBuV/m)		Margin (dB)	
	pk	Qpk/Avg					pk	Qpk/Avg	pk	Qpk/Avg	pk	Qpk/Avg
LCH												
2706.9	41.80	27.80	H	150	0	5.55	47.35	33.35	74.0	54.0	26.6	20.6
2706.9	42.10	27.80	V	150	0	5.55	47.65	33.35	74.0	54.0	26.3	20.6
MCH												
2745.6	42.30	27.80	H	150	0	5.65	47.95	33.45	74.0	54.0	26.1	20.6
2745.6	41.90	27.80	V	150	0	5.65	47.55	33.45	74.0	54.0	26.5	20.6
HCH												
2783.4	42.50	27.90	H	150	0	5.74	48.24	33.64	74.0	54.0	25.8	20.4
2783.4	42.20	27.80	V	150	0	5.74	47.94	33.54	74.0	54.0	26.1	20.5

Sample Calculation:

$$R_c = R_u + CF_T$$

Where:

- CF_T = Total Correction Factor (AF+CA+AG)-DC (Average Measurements Only)
- R_u = Uncorrected Reading
- R_c = Corrected Level
- AF = Antenna Factor
- CA = Cable Attenuation
- AG = Amplifier Gain
- DC = Duty Cycle Correction Factor

Example Calculation: Peak

Corrected Level: 42.50 + 5.74 = 48.24 dBuV/m

Margin: 74dBuV/m – 48.24 dBuV/m = 25.8 dB

Example Calculation: Average

Corrected Level: 27.90 + 5.74 = 33.64 dBuV/m

Margin: 54 dBuV/m – 33.64 dBuV/m = 20.4 dB

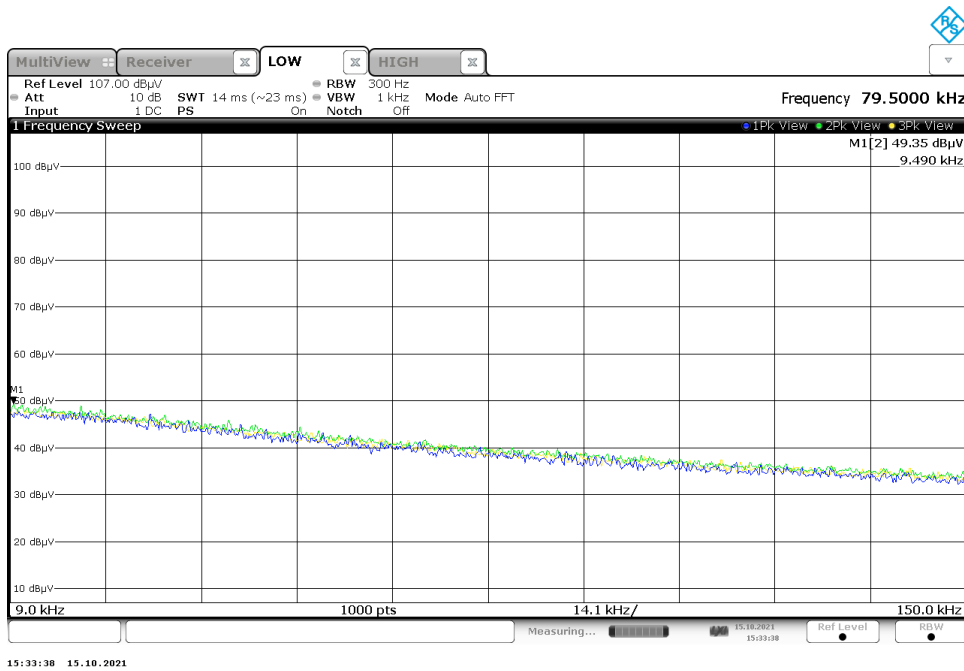

Figure A-1: Reference plot for Radiated Spurious Emissions – 9 kHz – 150 kHz

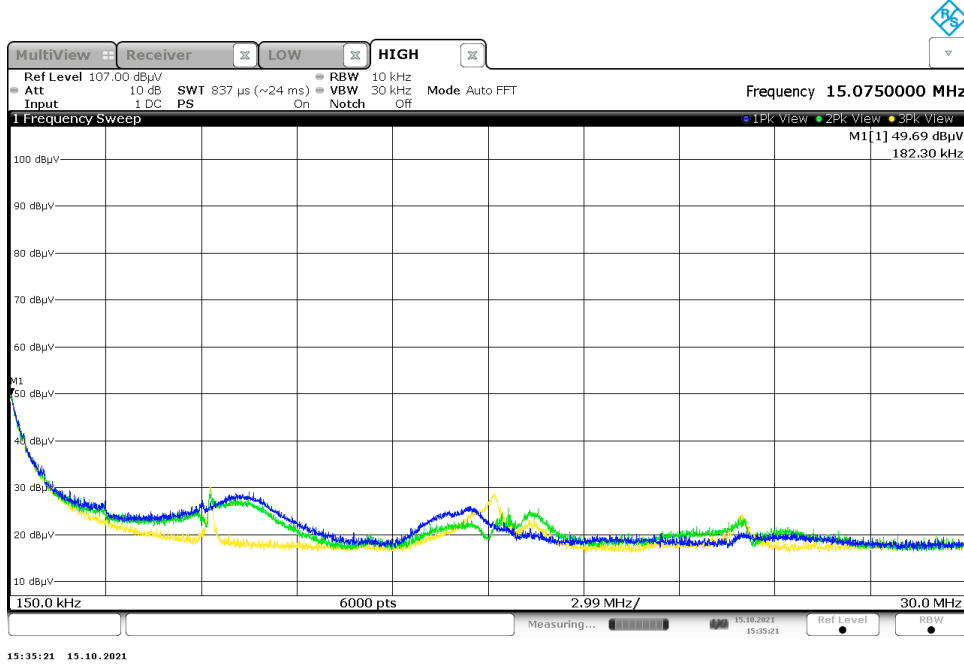

Figure A-2: Reference plot for Radiated Spurious Emissions – 150kHz - 30MHz
Note: Emissions above the noise floor are ambient not associated with the EUT.

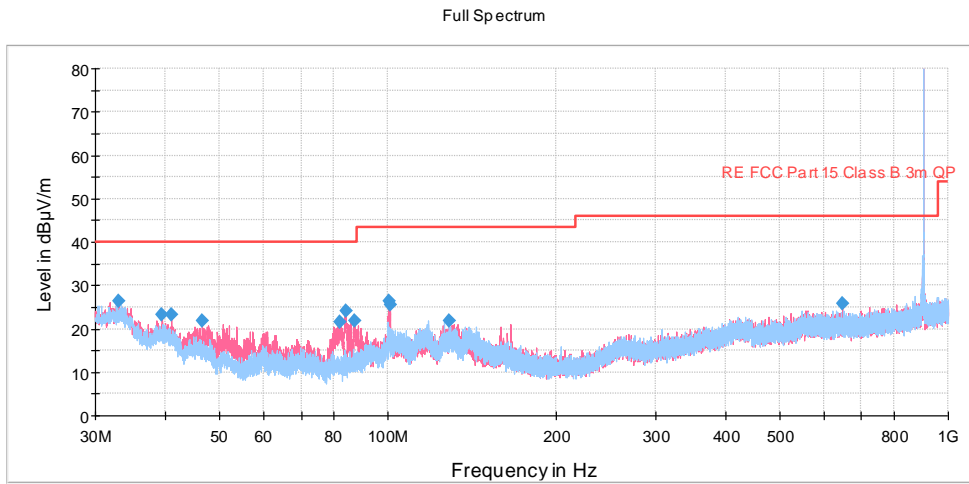

Figure A-3: Reference plot for Radiated Spurious Emissions – 30MHz - 1GHz

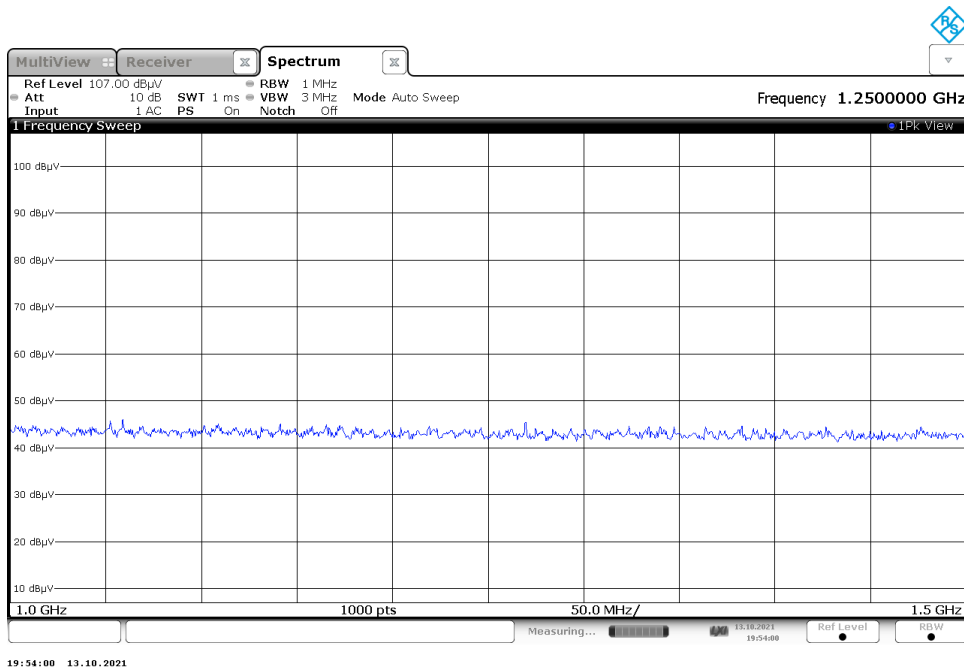

Figure A-4: Reference plot for Radiated Spurious Emissions – 1GHz – 1.5 GHz

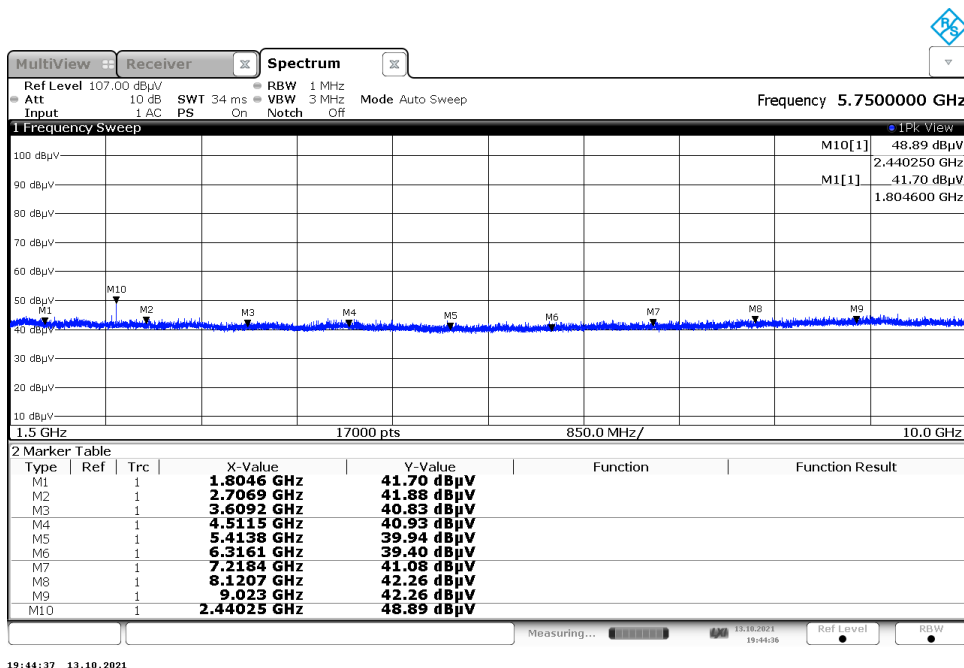

Figure A-5: Reference plot for Radiated Spurious Emissions – 1.5 GHz – 10 GHz
 Note: Emissions in and around 2.4 GHz are ambient noise and not associated with the EUT.

2.6 Test Equipment Used

Table 2.6-1 –Equipment List

Asset ID	Manufacturer	Model	Equipment Type	Serial Number	Last Calibration Date	Calibration Due Date
628	EMCO	6502	Active Loop Antenna 10kHz-30MHz	9407-2877	6/8/2021	6/8/2023
857	ETS Lindgren	3117	Horn Antenna 1-18GHz	00153608	11/12/2019	11/12/2021
DEMC3161	Ametek CTS Germany GmbH	CBL 6112D	Bilog Antenna; Attenuator	51323	3/19/2021	3/19/2022
213	TEC	PA 102	Amplifier	44927	7/30/2021	7/30/2022
22	Hewlett Packard	8449B	High Frequency Pre-Amp	3008A00526	11/19/2020	11/19/2021
331	Microwave Circuits	H1G513G1	Microwave Bandpass Filter	31417	6/9/2021	6/9/2022
827	(-)	997 Rack Cable	TS8997 Rack Cable Set	N/A	9/4/2020	12/4/2021
267	Hewlett Packard	N1911A	Power Meter	MY45100129	7/27/2021	7/27/2023
882	Rohde & Schwarz	ESW44	Test Receiver	111961	6/24/2021	6/24/2022
836	ETS Lindgren	SAC Cable Set	SAC Cable Set includes 620, 837, 838	N/A	5/11/2021	5/11/2022
3010	Rohde & Schwarz	ENV216	Two-Line V-Network	3010	6/23/2021	6/23/2022
872	Agilent	E7402A	EMC Spectrum Analyzer	US40240258	6/22/2021	6/22/2022
861	Com-Power Corporation	LI-1100C	Line Impedance Stabilization Network	20180038	2/26/2021	2/26/2022
862	Com-Power Corporation	LI01100C	Line Impedance Stabilization Network	20180039	2/26/2021	2/26/2022
703	Hewlett Packard	8594E	Spectrum Analyzer	3523A02134	NCR	NCR
856	Huber & Suhner	Multiflex 104	Blue Cable	326050	NCR	NCR
691	Com-Power Corp.	691	E-Field Fine Tip (100kHz to 5GHz), H-Field Loop (9kHz to 5GH	151514	NCR	NCR
494	Omega	iBTHX-W	Environmental Sensor	9460211	11/3/2020	11/3/2021
813	PMM	9010	EMI Receiver; RF Input 50ohm; 10Hz-50MHz; 10Hz-30MHz	697WW30606	6/8/2021	6/8/2022
168	Hewlett Packard	11947A	Transient Pulse Limiter	44829	3/3/2021	3/3/2022

N/A – Not Applicable

NCR – No Calibration Required

3 Diagram of Test Set-ups

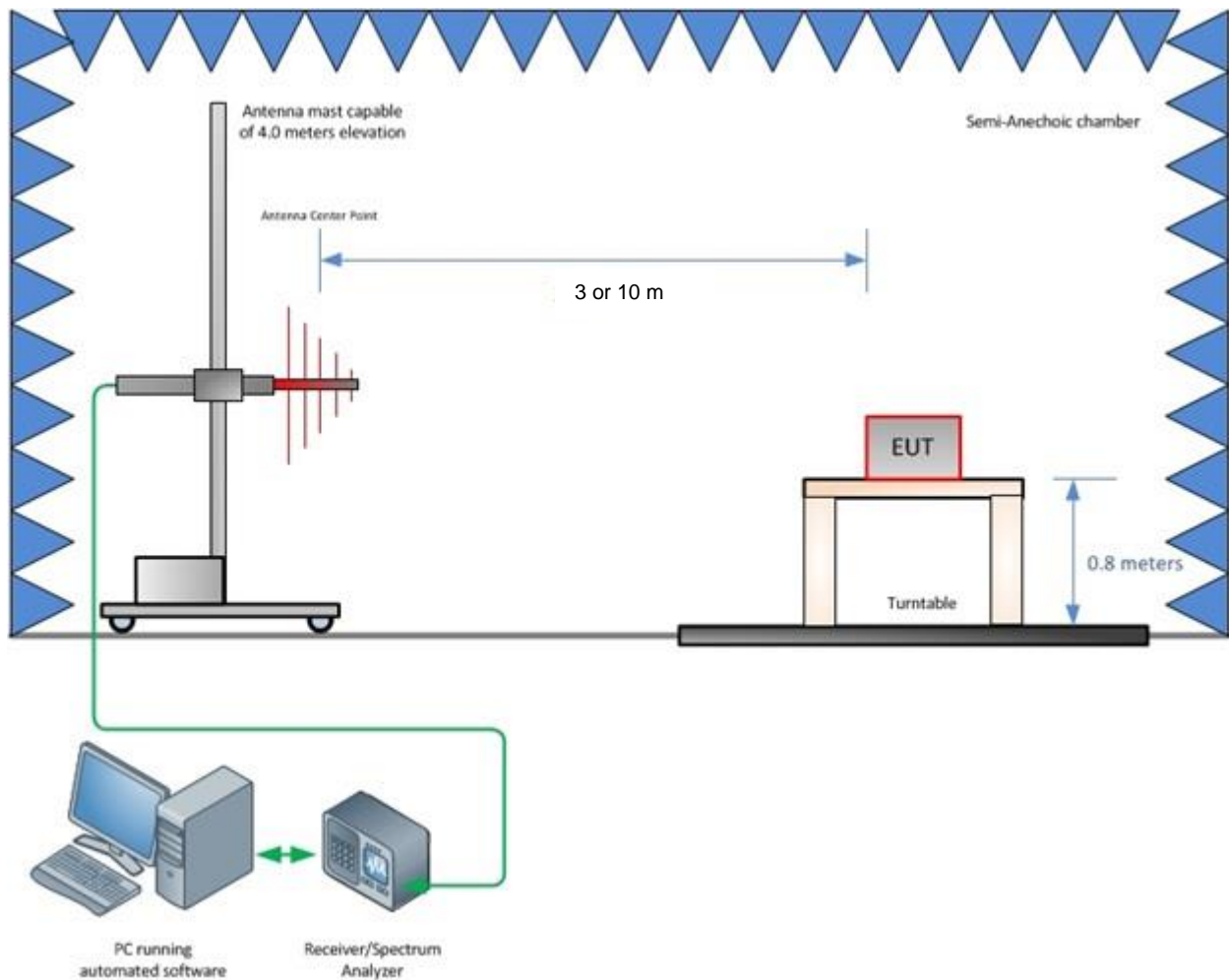

Figure 3-1 – Radiated Emissions Test Setup up to 1 GHz

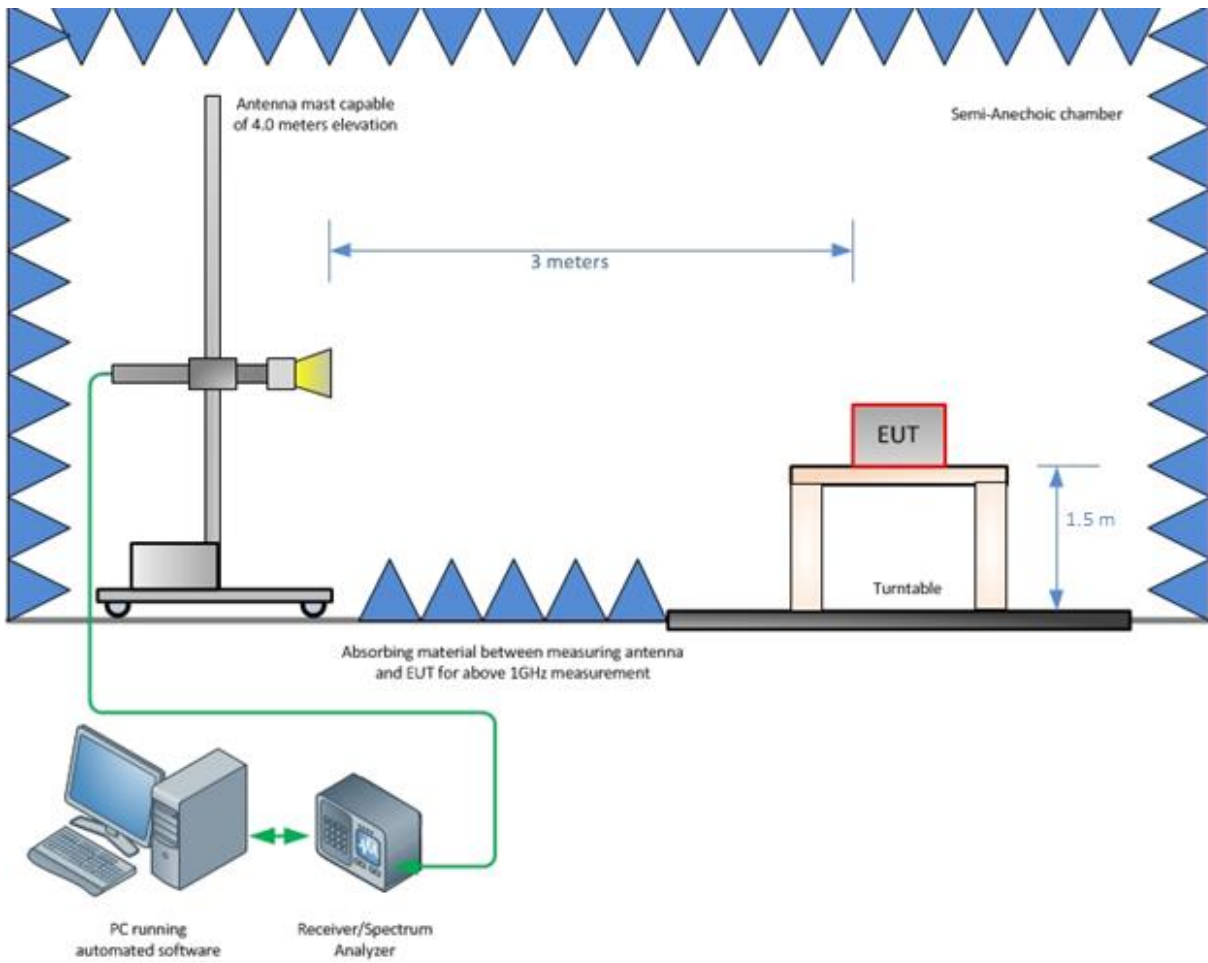

Figure 3-2 – Radiated Emissions Test Setup above 1 GHz

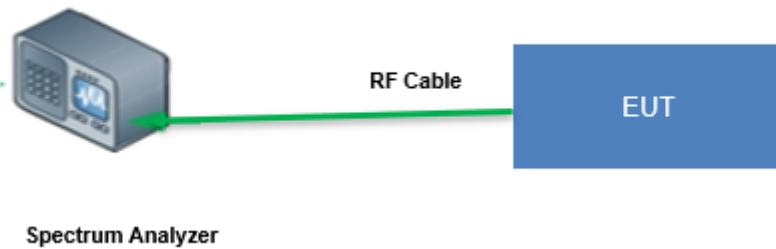

Figure 3-3 – Conducted Test Setup: Antenna Port measurement

4 Accreditation, Disclaimers and Copyright

TÜV SÜD America Inc.'s reports apply only to the specific sample tested under stated test conditions. It is the manufacturer's responsibility to assure the continued compliance of production units of this model. TÜV SÜD America, Inc. shall have no liability for any deductions, inferences or generalizations drawn by the client or others from TÜV SÜD America, Inc.'s issued reports.

This report is the confidential property of the client. As a mutual protection to our clients, the public and TÜV SÜD America, Inc., extracts from the test report shall not be reproduced, except in full without TÜV SÜD America, Inc.'s written approval.

This report must not be used to claim product certification, approval, or endorsement by A2LA, NIST, or any agency of the federal government.

STATEMENT OF MEASUREMENT UNCERTAINTY

The expanded laboratory measurement uncertainty figures (U_{Lab}) provided below correspond to an expansion factor (coverage factor) $k = 1.96$ which provide confidence levels of 95%.

Table 4-1: Estimation of Measurement Uncertainty

Parameter	U_{lab}
Occupied Channel Bandwidth	$\pm 0.009 \%$
RF Conducted Output Power	$\pm 0.349 \text{ dB}$
Power Spectral Density	$\pm 0.372 \text{ dB}$
Antenna Port Conducted Emissions	$\pm 1.264 \text{ dB}$
Radiated Emissions $\leq 1 \text{ GHz}$	$\pm 5.814 \text{ dB}$
Radiated Emissions $> 1 \text{ GHz}$	$\pm 4.318 \text{ dB}$
Temperature	$\pm 0.860 \text{ }^\circ\text{C}$
Radio Frequency	$\pm 2.832 \times 10^{-8}$
AC Power Line Conducted Emissions	$\pm 3.360 \text{ dB}$

TEST EQUIPMENT

All measurement instrumentation is traceable to the National Institute of Standards and Technology and is calibrated to meet test method standard requirements and/or manufacturer's specifications