



Excellence in Compliance Testing

Certification Test Report

FCC ID: R7PNG0R1S2

IC: 5294A-NG0R1S2

FCC Rule Part: 15.247

IC Radio Standards Specification: RSS-210

ACS Report Number: 12-0182.W06.1A

Manufacturer: Landis+Gyr Technology, Inc.

Model: Gridstream S4 Modular SCADA/DA

Test Begin Date: May 4, 2012

Test End Date: July 24, 2012

Report Issue Date: November 28, 2012



FOR THE SCOPE OF ACCREDITATION UNDER LAB Code 200612-0

This report is not be used to claim certification, approval, or endorsement by NVLAP, NIST or any government agency.

Reviewed by: _____

Kirby Munroe

Director, Wireless Certifications

ACS, Inc.

This test report shall not be reproduced except in full. This report may be reproduced in part with prior written consent of ACS, Inc. The results contained in this report are representative of the sample(s) submitted for evaluation.

This report contains 31 pages

TABLE OF CONTENTS

1	GENERAL	3
1.1	PURPOSE.....	3
1.2	PRODUCT DESCRIPTION	3
1.3	TEST METHODOLOGY AND CONSIDERATIONS	3
2	TEST FACILITIES.....	4
2.1	LOCATION	4
2.2	LABORATORY ACCREDITATIONS/RECOGNITIONS/CERTIFICATIONS	4
2.3	RADIATED EMISSIONS TEST SITE DESCRIPTION	5
2.3.1	<i>Semi-Anechoic Chamber Test Site</i>	5
2.3.2	<i>Open Area Tests Site (OATS)</i>	6
2.4	CONDUCTED EMISSIONS TEST SITE DESCRIPTION	7
3	APPLICABLE STANDARD REFERENCES.....	7
4	LIST OF TEST EQUIPMENT.....	8
5	SUPPORT EQUIPMENT.....	9
6	EQUIPMENT UNDER TEST SETUP BLOCK DIAGRAM.....	9
7	SUMMARY OF TESTS.....	10
7.1	ANTENNA REQUIREMENT – FCC: SECTION 15.203	10
7.2	POWER LINE CONDUCTED EMISSIONS – FCC: SECTION 15.207 IC: RSS-GEN 7.2.4.....	10
7.2.1	<i>Measurement Procedure</i>	10
7.2.2	<i>Measurement Results</i>	10
7.3	PEAK OUTPUT POWER - FCC SECTION 15.247(B)(2) IC: RSS-210 A8.4(1).....	13
7.3.1	<i>Measurement Procedure (Conducted Method)</i>	13
7.3.2	<i>Measurement Results</i>	13
7.4	CHANNEL USAGE REQUIREMENTS	14
7.4.1	<i>Carrier Frequency Separation – FCC: Section 15.247(a)(1) IC: RSS-210 A8.1(b)</i>	14
7.4.1.1	Measurement Procedure.....	14
7.4.1.2	Measurement Results	14
7.4.2	<i>Number of Hopping Channels – FCC: Section 15.247(a)(1)(i) IC: RSS-210 A8.1(c)</i>	15
7.4.3	<i>Channel Dwell Time – FCC: Section 15.247(a)(1)(i) IC: RSS-210 A8.1(c)</i>	17
7.4.3.1	Measurement Procedure.....	17
7.4.4	<i>20dB / 99% Bandwidth - FCC: Section 15.247(a)(1)(i) IC: RSS-210 A8.1(c)</i>	17
7.4.4.1	Measurement Procedure.....	17
7.4.4.2	Measurement Results	17
7.5	BAND-EDGE COMPLIANCE AND SPURIOUS EMISSIONS-FCC 15.247(D) IC: RSS-210 A8.5	23
7.5.1	<i>Band-Edge Compliance of RF Conducted Emissions</i>	23
7.5.1.1	Measurement Procedure.....	23
7.5.1.2	Measurement Results	23
7.5.2	<i>RF Conducted Spurious Emissions</i>	25
7.5.2.1	Measurement Procedure.....	25
7.5.2.2	Measurement Results	25
7.5.3	<i>Radiated Spurious Emissions - FCC Section 15.205 IC: RSS-210 2.6</i>	27
7.5.3.1	Measurement Procedure.....	27
7.5.3.2	Measurement Results	27
7.5.3.3	Sample Calculation:	31
8	CONCLUSION.....	31

1 GENERAL

1.1 Purpose

The purpose of this report is to demonstrate compliance with Part 15 Subpart C of the FCC's Code of Federal Regulations and Industry Canada's Radio Standards Specification RSS-210 for Certification.

1.2 Product description

The Gridstream S4 Modular SCADA/DA consists of a 900 MHz transceiver on a single printed circuit board. This single board radio is for use by OEM vendors wanting to incorporate Smart Grid capability within their SCADA / DA and metering products.

The Gridstream S4 Modular SCADA/DA provides both an integral PCB F antenna and external whip antenna. To accommodate the integral antenna the PCB is slightly extended.

Technical Details:

The EUT provides distinct frequency hopping modes of operation as outlined below.

Mode of Operation	Frequency Range (MHz)	Number of Channels	Channel Separation (kHz)	Data Rates Supported (kbps)
Wide Mode	902.3 - 927.8	86	300	9.6, 19.2, 38.4, 115.2
Narrow Mode	904.0 - 927.9	240	100	9.6, 19.2, 38.4
SUN Mode	902.2 – 927.8	129	200	50.0

Modulation Format: GFSK
Antenna Type / Gain: PCB F 0 dBi (Integral), Wave 5 dBi (External via MCX)
Operating Voltage: 5 VDC

Manufacturer Information:
Landis+Gyr Technology, Inc.
30000 Mill Creek Ave., Suite 100
Alpharetta, GA 30022

Test Sample Serial Numbers: 91588077 (Integral antenna), 91588082 (External antenna)

Test Sample Condition: The test samples were provided in good working order with no visible defects.

1.3 Test Methodology and Considerations

All modes of operation, including all available data rates, were evaluated. The data presented in this report represents the worst case where applicable. The EUT was tested for radiated emissions in multiple orientations.

Based on the PCB differences required to accommodate both antenna types, both PCB variants were evaluated for radiated emissions.

DAC power setting used during testing:
Integral Antenna: 140
External Antenna: 142

2 TEST FACILITIES

2.1 Location

The radiated and conducted emissions test sites are located at the following address:

Advanced Compliance Solutions
5015 B.U. Bowman Drive
Buford, GA 30518
Phone: (770) 831-8048
Fax: (770) 831-8598

2.2 Laboratory Accreditations/Recognitions/Certifications

ACS is accredited to ISO/IEC 17025 by the National Institute of Standards and Technology under their National Voluntary Laboratory Accreditation Program (NVLAP), Lab Code 200612-0. Unless otherwise specified, all tests methods described within this report are covered under the ISO/IEC 17025 scope of accreditation.

The Semi-Anechoic Chamber Test Site, Open Area Test Site (OATS) and Conducted Emissions Site have been fully described, submitted to, and accepted by the FCC, Industry Canada and the Japanese Voluntary Control Council for Interference by information technology equipment.

FCC Registration Number: 511277

Industry Canada Lab Code: IC 4175A-1

VCCI Member Number: 1831

- VCCI OATS Registration Number R-1526
- VCCI Conducted Emissions Site Registration Number: C-1608

2.3 Radiated Emissions Test Site Description

2.3.1 Semi-Anechoic Chamber Test Site

The Semi-Anechoic Chamber Test Site consists of a 20' x 30' x 18' shielded enclosure. The chamber is lined with Toyo Ferrite Grid Absorber, model number FFG-1000. The ferrite tile grid is 101 x 101 x 19mm thick and weighs approximately 550 grams. These tiles are mounted on steel panels and installed directly on the inner walls of the chamber.

The turntable is 150cm in diameter and is located 160cm from the back wall of the chamber. The chamber is grounded via 1 – 8' copper ground rod, installed at the center of the back wall, it is bound to the ground plane using 3/4" stainless steel braided cable.

The turntable is all steel, flush mounted table installed in an all steel frame. The table is remotely operated from inside the control room located 25' from the range. The turntable is electrically bonded to the surrounding ground plane via steel fingers installed on the edge of the turn table. The steel fingers make constant contact with the ground plane during operation.

Behind the turntable is a 3' x 6' x 4' deep shielded pit used for support equipment if necessary. The pit is equipped with 1 – 4" PVC chases from the turntable to the pit that allow for cabling to the EUT if necessary. The underside of the turntable can be accessed from the pit so cables can be supplied to the EUT from the pit.

A diagram of the Semi-Anechoic Chamber Test Site is shown in Figure 2.3-1 below:

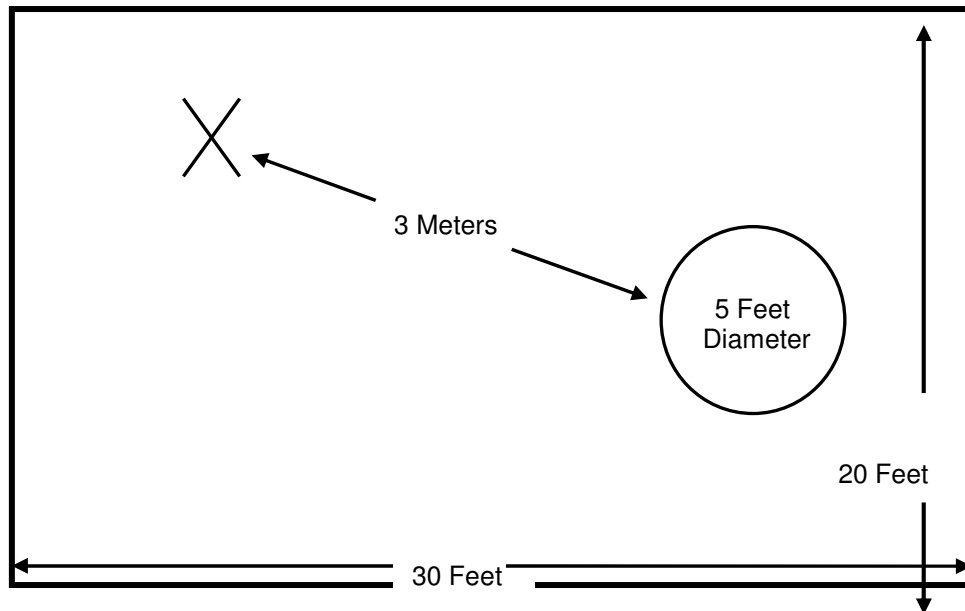

Figure 2.3-1: Semi-Anechoic Chamber Test Site

2.3.2 Open Area Tests Site (OATS)

The open area test site consists of a 40' x 66' concrete pad covered with a perforated electro-plated galvanized sheet metal. The perforations in the sheet metal are 1/8" holes that are staggered every 3/16". The individual sheets are placed to overlap each other by 1/4" and are riveted together to provide a continuous seam. Rivets are spaced every 3" in a 3 x 20 meter perimeter around the antenna mast and EUT area. Rivets in the remaining area are spaced as necessary to properly secure the ground plane and maintain the electrical continuity.

The entire ground plane extends 12' beyond the turntable edge and 16' beyond the antenna mast when set to a 10 meter measurement distance. The ground plane is grounded via 4 – 8' copper ground rods, each installed at a corner of the ground plane and bound to the ground plane using 3/4" stainless steel braided cable.

The turntable is an all aluminum 10' flush mounted table installed in an all aluminum frame. The table is remotely operated from inside the control room located 40' from the range. The turntable is electrically bonded to the surrounding ground plane via steel fingers installed on the edge of the turn table. The steel fingers make constant contact with the ground plane during operation.

Adjacent to the turntable is a 7' x 7' square and 4' deep concrete pit used for support equipment if necessary. The pit is equipped with 5 – 4" PVC chases from the pit to the control room that allow for cabling to the EUT if necessary. The underside of the turntable can be accessed from the pit so cables can be supplied to the EUT from the pit. The pit is covered with 2 sheets of 1/4" diamond style re-enforced steel sheets. The sheets are painted to match the perforated steel ground plane; however the underside edges have been masked off to maintain the electrical continuity of the ground plane. All reflecting objects are located outside of the ellipse defined in ANSI C63.4.

A diagram of the Open Area Test Site is shown in Figure 2.3-2 below:

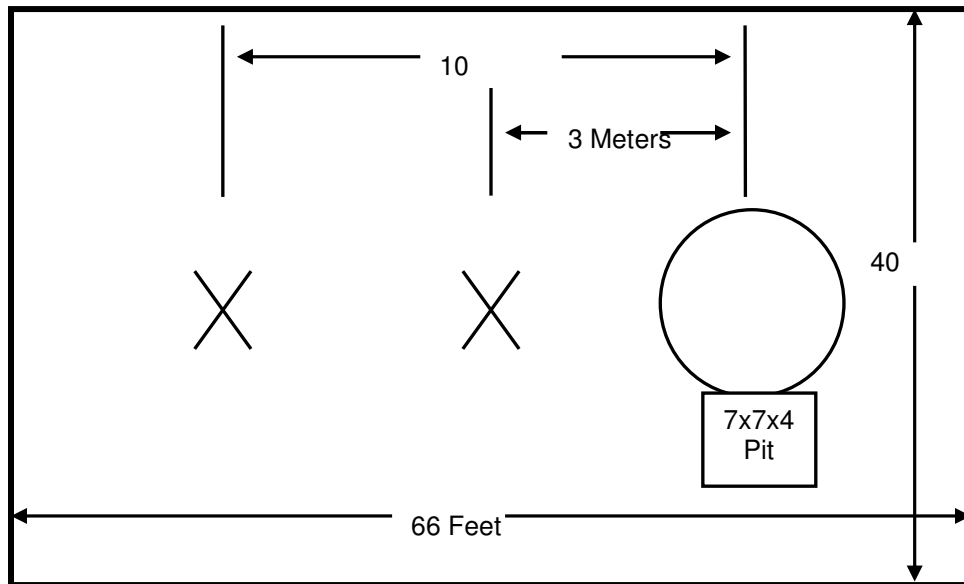

Figure 2.3-2: Open Area Test Site

2.4 Conducted Emissions Test Site Description

The AC mains conducted EMI site is located in the main EMC lab. It consists of an 8' x 8' solid aluminum horizontal ground reference plane (GRP) bonded every 3" to an 8' X 8' vertical ground plane.

The site is of sufficient size to test table top and floor standing equipment in accordance with section 6.1.4 of ANSI C63.4.

A diagram of the room is shown below in figure 2.4-1:

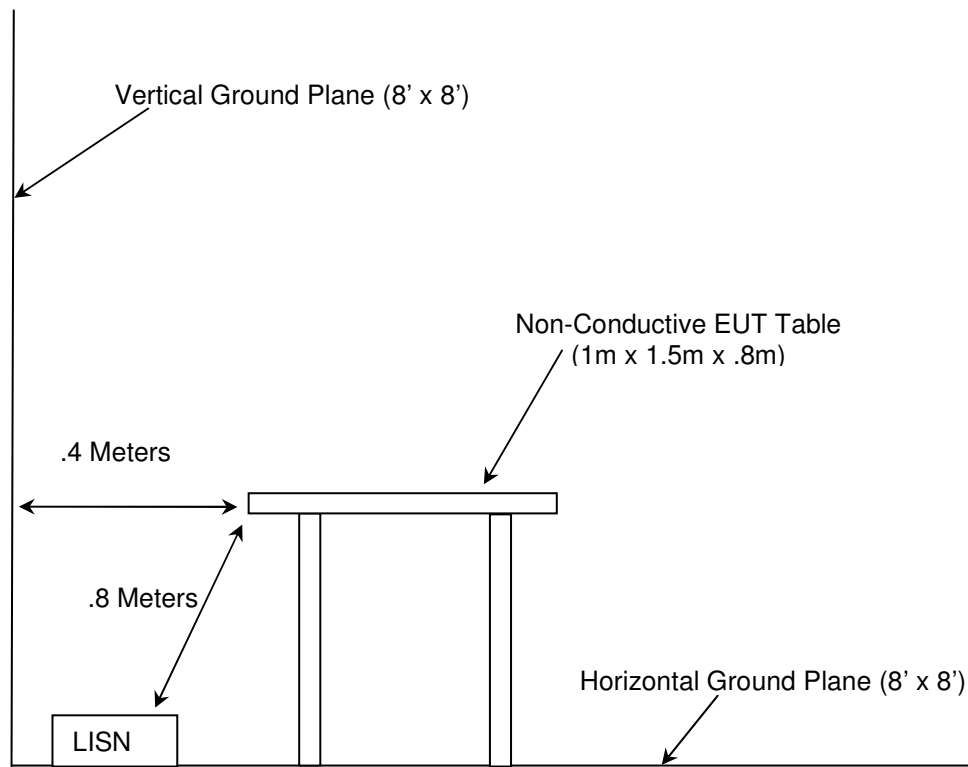

Figure 2.4-1: AC Mains Conducted EMI Site

3 APPLICABLE STANDARD REFERENCES

The following standards were used:

- ❖ ANSI C63.4-2003: Method of Measurements of Radio-Noise Emissions from Low-Voltage Electrical and Electronic Equipment in the 9KHz to 40GHz
- ❖ US Code of Federal Regulations (CFR): Title 47, Part 2, Subpart J: Equipment Authorization Procedures, 2012
- ❖ US Code of Federal Regulations (CFR): Title 47, Part 15, Subpart C: Radio Frequency Devices, Intentional Radiators, 2012
- ❖ FCC Public Notice DA 00-705 – Filing and Measurement Guidelines for Frequency Hopping Spread Spectrum Systems, March 30, 2000
- ❖ Industry Canada Radio Standards Specification: RSS-210 – Low-power License-exempt Radiocommunication Devices (All Frequency Bands): Category I Equipment, Issue 8, December 2010
- ❖ Industry Canada Radio Standards Specification: RSS-GEN – General Requirements and Information for the Certification of Radiocommunication Equipment, Issue 3, December 2010.

4 LIST OF TEST EQUIPMENT

The calibration interval of test equipment is annually or the manufacturer's recommendations. Where the calibration interval deviates from the annual cycle based on the instrument manufacturer's recommendations, it shall be stated below.

Table 4-1: Test Equipment

AssetID	Manufacturer	Model #	Equipment Type	Serial #	Last Calibration Date	Calibration Due Date
1	Rohde & Schwarz	ESMI - Display	Spectrum Analyzers	833771/007	9/23/2010	9/23/2012
2	Rohde & Schwarz	ESMI-Receiver	Spectrum Analyzers	839587/003	9/23/2010	9/23/2012
3	Rohde & Schwarz	ESMI - Display	Spectrum Analyzers	839379/011	5/26/2011	5/26/2013
4	Rohde & Schwarz	ESMI - Receiver	Spectrum Analyzers	833827/003	5/26/2011	5/26/2013
30	Spectrum Technologies	DRH-0118	Antennas	970102	4/27/2011	4/27/2013
40	EMCO	3104	Antennas	3211	2/11/2011	2/11/2013
73	Agilent	8447D	Amplifiers	2727A05624	9/30/2011	9/30/2012
153	EMCO	3825/2	LISN	9411-2268	1/13/2011	1/13/2013
167	ACS	Chamber EMI Cable Set	Cable Set	167	12/21/2011	12/21/2012
168	Hewlett Packard	11947A	Attenuators	44829	2/1/2012	2/1/2013
267	Agilent	N1911A	Meters	MY45100129	1/23/2012	1/23/2014
268	Agilent	N1921A	Sensors	MY45240184	1/17/2012	1/17/2014
283	Rohde & Schwarz	FSP40	Spectrum Analyzers	1000033	8/26/2011	8/26/2012
291	Florida RF Cables	SMRE-200W-12.0-SMRE	Cables	None	12/2/2011	12/2/2012
292	Florida RF Cables	SMR-290AW-480.0-SMR	Cables	None	4/2/2012	4/2/2013
324	ACS	Belden	Cables	8214	7/6/2011	7/6/2012
324	ACS	Belden	Cables	8214	6/26/2012	6/26/2013
337	Microwave Circuits	H1G513G1	Filters	282706	7/11/2011	7/11/2012
337	Microwave Circuits	H1G513G1	Filters	282706	7/2/2012	7/2/2013
338	Hewlett Packard	8449B	Amplifiers	3008A01111	3/1/2012	8/31/2012
339	Aeroflex/Weinschel	AS-18	Attenuators	7142	6/10/2011	6/10/2012
339	Aeroflex/Weinschel	AS-18	Attenuators	7142	6/4/2012	6/4/2013
412	Electro Metrics	LPA-25	Antennas	1241	7/28/2010	7/28/2012
422	Florida RF	SMS-200AW-72.0-SMR	Cables	805	12/2/2011	12/2/2012
562	United Microwave Products, Inc.	AA-190-00.48.0	Cables	562	8/11/2011	8/11/2012

5 SUPPORT EQUIPMENT

Table 5-1: Support Equipment

Item	Equipment Type	Manufacturer	Model Number	Serial Number
1	Bench Power Supply	Hewlett Packard	E3630A	KR64308603
2	Wall Wart Power Supply	Seven Star	SS105	N/A

6 EQUIPMENT UNDER TEST SETUP BLOCK DIAGRAM

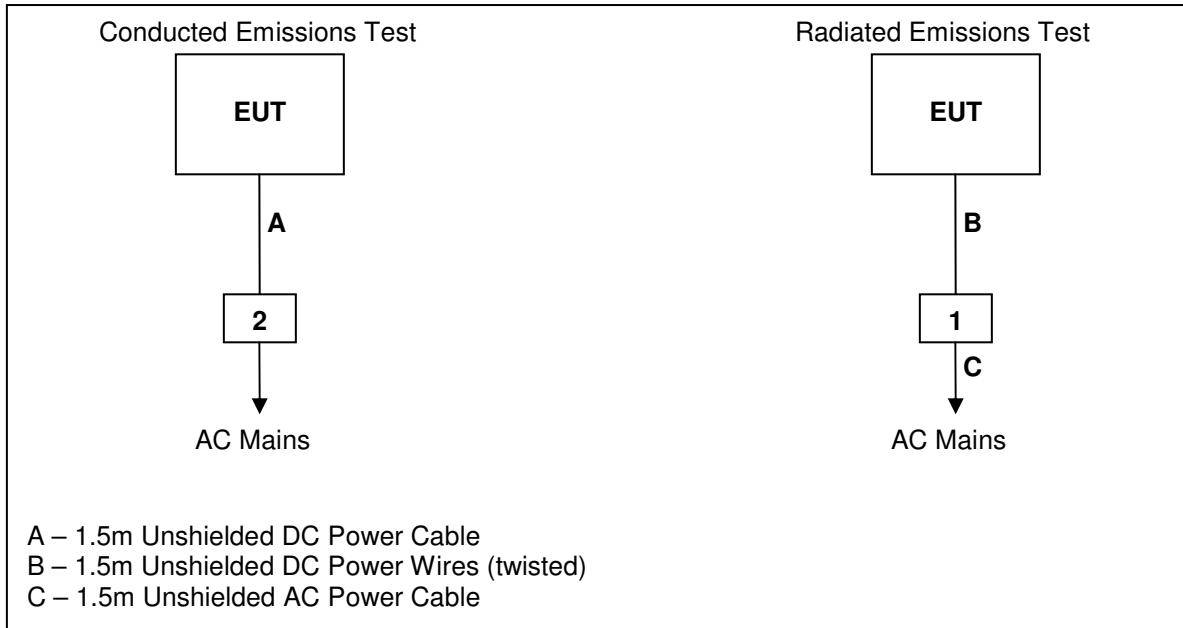

Figure 6-1: Test Setup Block Diagram

7 SUMMARY OF TESTS

Along with the tabular data shown below, plots were taken of all signals deemed important enough to document.

7.1 Antenna Requirement – FCC: Section 15.203

The EUT includes both a PCB Integrated F type antenna and external whip antenna. The antenna coupling for the external whip is N-type Male Reverse-Polarity. This product does not allow an external antenna in conjunction to the on-board antenna.

7.2 Power Line Conducted Emissions – FCC: Section 15.207 IC: RSS-Gen 7.2.4

7.2.1 Measurement Procedure

ANSI C63.4 sections 6 and 7 were the guiding documents for this evaluation. Conducted emissions were performed from 150kHz to 30MHz with the spectrum analyzer’s resolution bandwidth set to 9kHz and the video bandwidth set to 30kHz. The calculation for the conducted emissions is as follows:

Corrected Reading = Analyzer Reading + LISN Loss + Cable Loss
Margin = Applicable Limit - Corrected Reading

7.2.2 Measurement Results

Results of the test are shown below in and Tables 7.2.2-1 to 7.2.2-2.

Table 7.2.2-1: Conducted EMI Results – Integral Antenna – Line 1

Frequency (MHz)	Level (dBuV)	Transducer (dB)	Limit (dBuV)	Margin (dB)	Line	PE	Detector
0.570000	10.40	10.0	56	45.6	1	FLO	QP
0.726000	10.40	10.1	56	45.6	1	FLO	QP
0.822000	10.30	10.0	56	45.7	1	FLO	QP
1.056000	10.10	10.0	56	45.9	1	FLO	QP
1.296000	10.20	10.0	56	45.8	1	FLO	QP
1.578000	10.10	10.0	56	45.9	1	FLO	QP
1.830000	10.20	10.0	56	45.8	1	FLO	QP
2.676000	9.70	10.0	56	46.3	1	FLO	QP
4.572000	9.60	10.0	56	46.4	1	FLO	QP
4.878000	9.50	10.0	56	46.5	1	FLO	QP
0.594000	7.60	10.0	46	38.4	1	FLO	AV
0.732000	7.50	10.1	46	38.5	1	FLO	AV
0.798000	7.60	10.1	46	38.5	1	FLO	AV
1.056000	7.40	10.0	46	38.6	1	FLO	AV
1.272000	7.40	10.0	46	38.6	1	FLO	AV
1.572000	7.40	10.0	46	38.6	1	FLO	AV
1.800000	7.40	10.0	46	38.6	1	FLO	AV
2.670000	6.90	10.0	46	39.1	1	FLO	AV
4.572000	7.00	10.0	46	39.0	1	FLO	AV
4.920000	7.00	10.0	46	39.0	1	FLO	AV

Table 7.2.2-2: Conducted EMI Results – Integral Antenna – Line 2

Frequency (MHz)	Level (dBuV)	Transducer (dB)	Limit (dBuV)	Margin (dB)	Line	PE	Detector
0.570000	10.40	10.0	56	45.6	2	FLO	QP
0.726000	10.40	10.1	56	45.6	2	FLO	QP
0.996000	10.00	10.0	56	46.0	2	FLO	QP
1.338000	10.00	10.0	56	46.0	2	FLO	QP
1.962000	9.90	10.0	56	46.1	2	FLO	QP
2.448000	9.50	10.0	56	46.5	2	FLO	QP
3.162000	9.60	9.9	56	46.4	2	FLO	QP
3.798000	9.70	9.9	56	46.3	2	FLO	QP
4.746000	9.40	10.0	56	46.6	2	FLO	QP
4.872000	9.40	10.0	56	46.6	2	FLO	QP
0.582000	7.50	10.0	46	38.5	2	FLO	AV
0.708000	7.60	10.1	46	38.5	2	FLO	AV
1.020000	7.40	10.0	46	38.6	2	FLO	AV
1.332000	7.30	10.0	46	38.7	2	FLO	AV
1.938000	7.30	10.0	46	38.7	2	FLO	AV
2.430000	6.90	10.0	46	39.1	2	FLO	AV
3.234000	6.90	9.9	46	39.1	2	FLO	AV
3.828000	6.90	9.9	46	39.1	2	FLO	AV
4.722000	7.00	10.0	46	39.0	2	FLO	AV
4.842000	7.00	10.0	46	39.0	2	FLO	AV

Table 7.2.2-3: Conducted EMI Results – External Antenna – Line 1

Frequency (MHz)	Level (dBuV)	Transducer (dB)	Limit (dBuV)	Margin (dB)	Line	PE	Detector
0.600000	10.20	10.0	56	45.8	1	FLO	QP
0.660000	10.40	10.0	56	45.6	1	FLO	QP
1.464000	13.50	10.0	56	42.5	1	FLO	QP
1.584000	10.10	10.0	56	45.9	1	FLO	QP
1.824000	10.00	10.0	56	46.0	1	FLO	QP
2.160000	9.50	10.0	56	46.5	1	FLO	QP
2.232000	9.50	10.0	56	46.5	1	FLO	QP
2.802000	9.30	10.0	56	46.7	1	FLO	QP
4.452000	9.80	10.0	56	46.2	1	FLO	QP
26.808000	10.70	9.4	60	49.3	1	FLO	QP
0.630000	7.50	10.0	46	38.5	1	FLO	AV
0.720000	7.60	10.1	46	38.4	1	FLO	AV
1.440000	7.20	10.0	46	38.8	1	FLO	AV
1.578000	7.30	10.0	46	38.7	1	FLO	AV
1.824000	7.20	10.0	46	38.8	1	FLO	AV
2.196000	7.00	10.0	46	39.0	1	FLO	AV
2.244000	6.90	10.0	46	39.1	1	FLO	AV
2.802000	6.80	10.0	46	39.2	1	FLO	AV
4.452000	7.00	10.0	46	39.0	1	FLO	AV
26.862000	7.50	9.4	50	42.5	1	FLO	AV

Table 7.2.2-4: Conducted EMI Results – External Antenna – Line 2

Frequency (MHz)	Level (dBuV)	Transducer (dB)	Limit (dBuV)	Margin (dB)	Line	PE	Detector
1.458000	14.10	10.0	56	41.9	2	FLO	QP
1.584000	9.90	10.0	56	46.1	2	FLO	QP
1.686000	10.10	10.0	56	45.9	2	FLO	QP
1.800000	9.80	10.0	56	46.2	2	FLO	QP
3.258000	9.20	9.9	56	46.8	2	FLO	QP
3.810000	9.50	9.9	56	46.5	2	FLO	QP
3.882000	9.40	9.9	56	46.7	2	FLO	QP
26.082000	11.40	9.3	60	48.6	2	FLO	QP
26.994000	11.80	9.4	60	48.2	2	FLO	QP
27.018000	12.70	9.4	73	47.3	2	FLO	QP
1.410000	7.40	10.0	46	38.6	2	FLO	AV
1.542000	7.40	10.0	46	38.6	2	FLO	AV
1.632000	7.30	10.0	46	38.7	2	FLO	AV
1.818000	7.40	10.0	46	38.6	2	FLO	AV
3.294000	6.90	9.9	46	39.1	2	FLO	AV
3.786000	6.90	9.9	46	39.1	2	FLO	AV
3.846000	7.00	9.9	46	39.0	2	FLO	AV
25.800000	8.00	9.3	50	42.0	2	FLO	AV
26.910000	8.30	9.4	50	41.7	2	FLO	AV
27.114000	8.10	9.4	50	41.9	2	FLO	AV

7.3 Peak Output Power - FCC Section 15.247(b)(2) IC: RSS-210 A8.4(1)

7.3.1 Measurement Procedure (Conducted Method)

The RF output port of the EUT was directly connected to the input of a power meter. The device employs >50 channels therefore the power is limited to 1 Watt.

7.3.2 Measurement Results

Results are shown below in Table 7.3.2-1 below:

Table 7.3.2-1: RF Output Power

Frequency [MHz]	Level [dBm]
902.2	29.06
915.0	29.06
927.9	29.05

7.4 Channel Usage Requirements

7.4.1 Carrier Frequency Separation – FCC: Section 15.247(a)(1) IC: RSS-210 A8.1(b)

7.4.1.1 Measurement Procedure

The RF output port of the EUT was directly connected to the input of the spectrum analyzer. The span of the spectrum analyzer was set wide enough to capture two adjacent peaks and the RBW and VBW were set to $\geq 1\%$ of the span.

Carrier frequency separation was measured for all modes of operation (i.e. wide mode, narrow mode and SUN mode) and data presented in section 7.4.1.2 below.

7.4.1.2 Measurement Results

The adjacent channel separation was measured to be 100 kHz for narrow mode (240 channels), 300kHz for wide mode (86 channels) and 200kHz for Sun Mode (129 channels). Results are shown below in Figures 7.4.1.2-1 to 7.4.1.2-3.

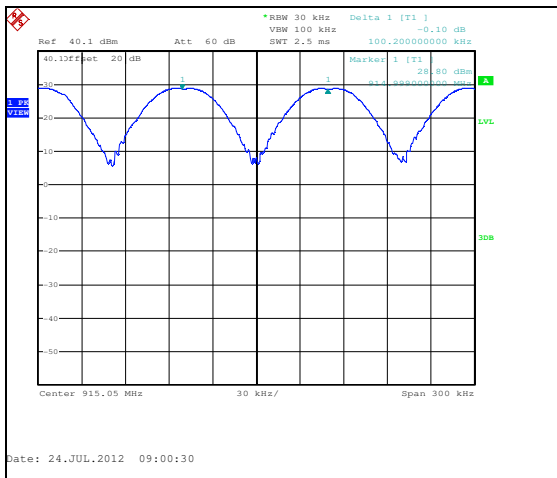

Figure 7.4.1.2-1: Narrow Mode

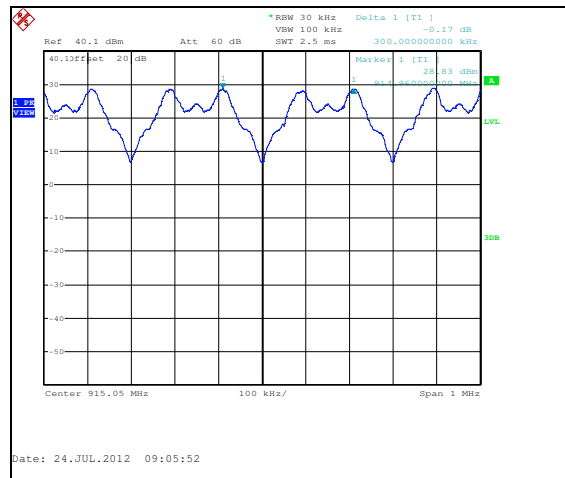

Figure 7.4.1.2-2: Wide Mode

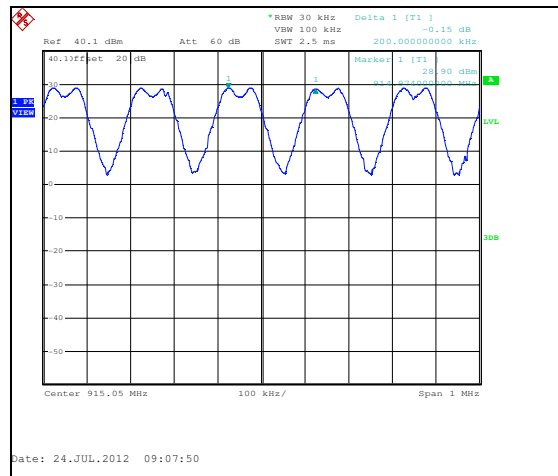
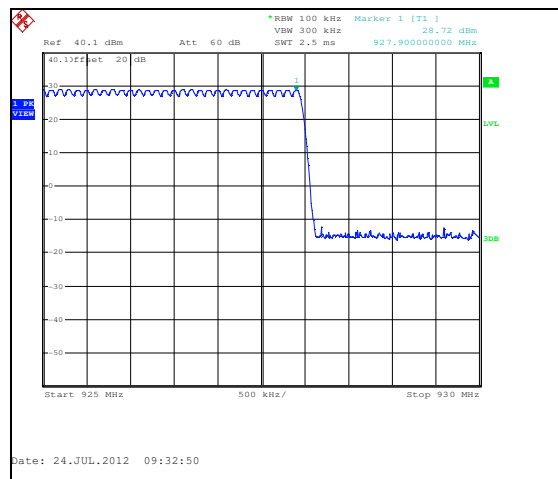
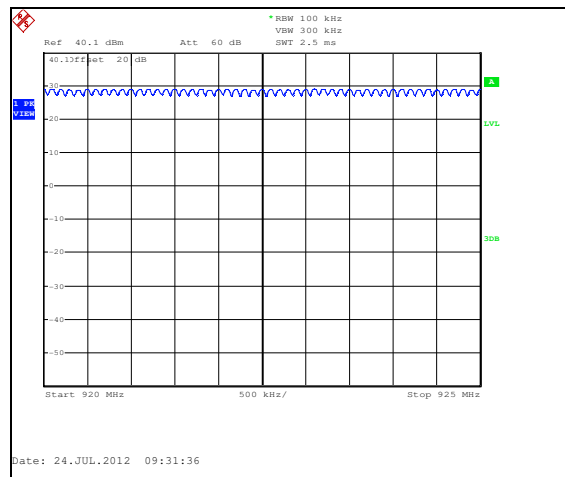
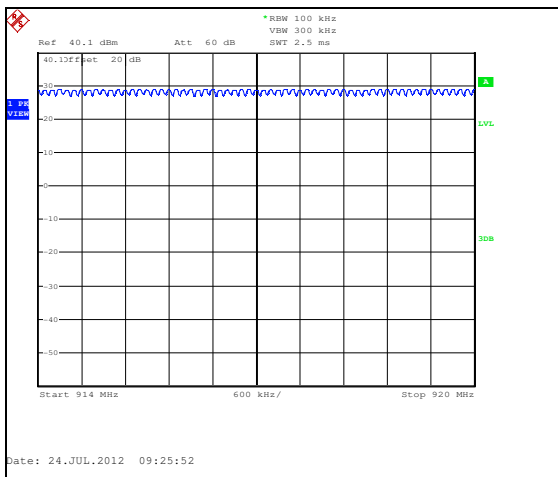
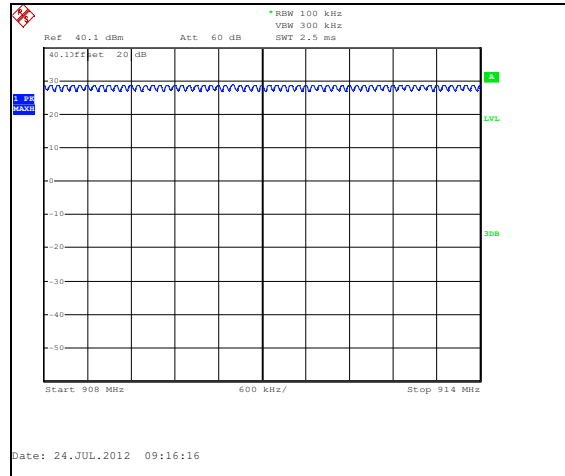
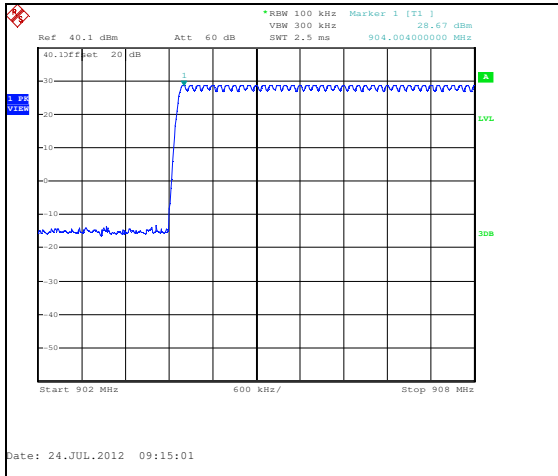

Figure 7.4.1.2-3: SUN Mode

7.4.2 Number of Hopping Channels – FCC: Section 15.247(a)(1)(i) IC: RSS-210 A8.1(c)

The device employs > 50 hopping channels under all modes and data rates. Results are shown below in Figures 7.4.2-1 to 7.4.2-10.



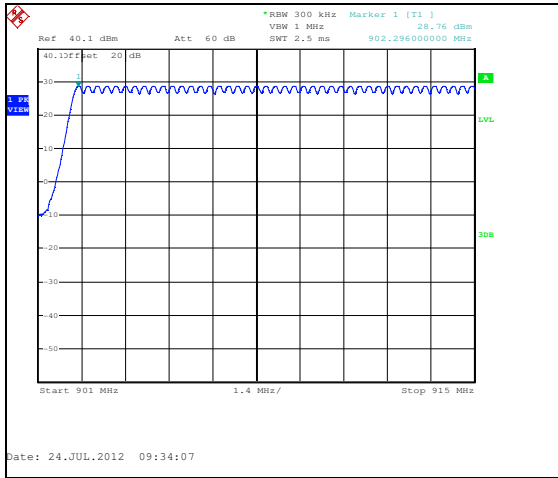

Figure 7.4.2-6: Wide Mode (86 Channels)

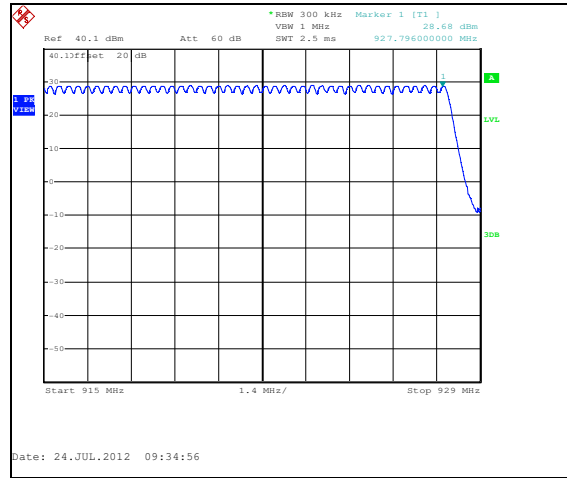

Figure 7.4.2-7: Wide Mode (86 Channels)

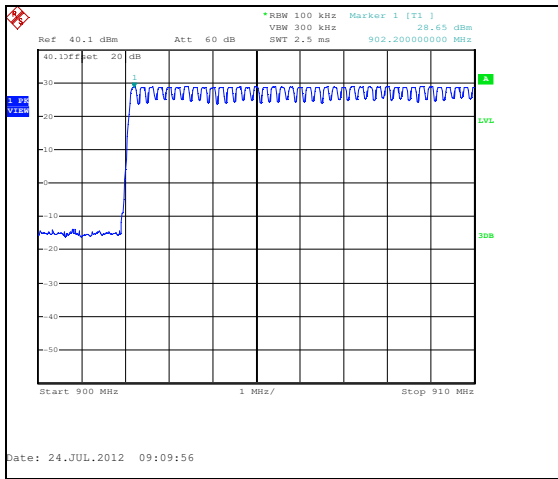

Figure 7.4.2-8: SUN Mode (129 Channels)

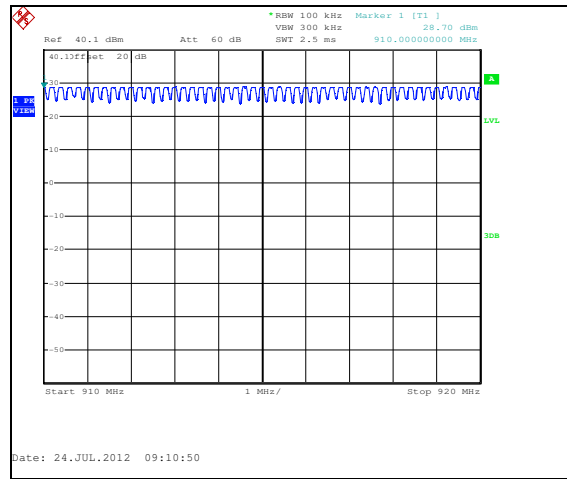

Figure 7.4.2-9: SUN Mode (129 Channels)

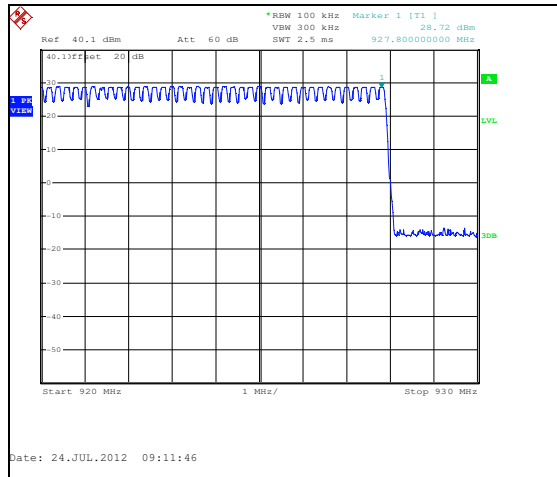

Figure 7.4.2-10: SUN Mode (129 Channels)

7.4.3 Channel Dwell Time – FCC: Section 15.247(a)(1)(i) IC: RSS-210 A8.1(c)

7.4.3.1 Measurement Procedure

The EUT test mode does not generate a worst case channel dwell time therefore a detailed engineering analysis is provided in the theory of operation.

As described in the theory of operation, the maximum channel transmitter dwell time is < 400ms per channel hop with the minimum period of 700ms between hops. Therefore the maximum time of occupancy on any one channel within a 10s or 20s period is <400ms for all modes of operation.

7.4.4 20dB / 99% Bandwidth - FCC: Section 15.247(a)(1)(i) IC: RSS-210 A8.1(c)

7.4.4.1 Measurement Procedure

The RF output port of the EUT was directly connected to the input of the spectrum analyzer. The span of the spectrum analyzer display was set between two times and five times the occupied bandwidth (OBW) of the emission. The RBW of the spectrum analyzer was set to approximately 1 % to 5 % of the OBW. The trace was set to max hold with a peak detector active. The Delta function of the analyzer was utilized to determine the 20 dB bandwidth of the emission.

The 99% occupied bandwidth was measured with the spectrum analyzer span set to fully display the emission and side bands. The RBW was to ~ 1% of the span. The trace was set to max hold with a sample detector. The occupied bandwidth measurement function of the analyzer was used for the 99% bandwidth.

7.4.4.2 Measurement Results

Results are shown below in Table 7.4.4.2-1 and Figures 7.4.4.2-1 through 7.4.4.2-30.

Table 7.4.4.2-1: 20dB / 99% Bandwidth

Frequency [MHz]	20dB Bandwidth [kHz]	99% Bandwidth [kHz]	Data Rate (kbps)
902.3	22.6	21.6	9.6
902.3	44.8	45	19.2
902.3	92.4	90	38.4
902.2	121.5	116.5	50.0
902.3	273.6	254.4	115.2
915.0	22.5	21.6	9.6
915.0	45.0	44.6	19.2
915.0	92.4	89.2	38.4
915.0	120.5	117.5	50.0
915.0	273.6	254.4	115.2
927.9	22.3	21.6	9.6
927.9	44.4	44.6	19.2
927.9	92.8	89.6	38.4
927.8	120.0	117	50.0
927.8	273.6	255.6	115.2

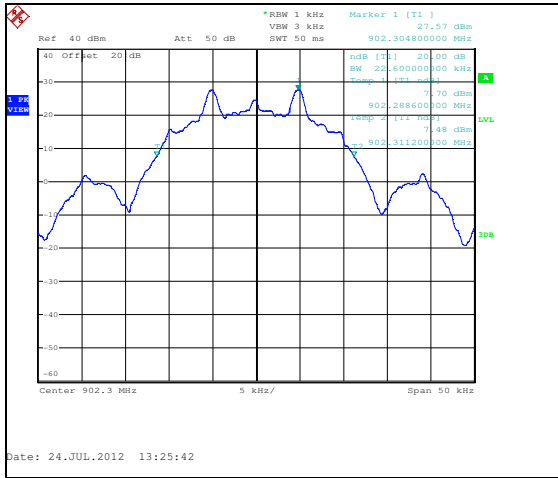

Figure 7.4.4.2-1: 20dB BW Low Channel - 9.6kbps



Figure 7.4.4.2-2: 20dB BW Low Channel - 19.2kbps

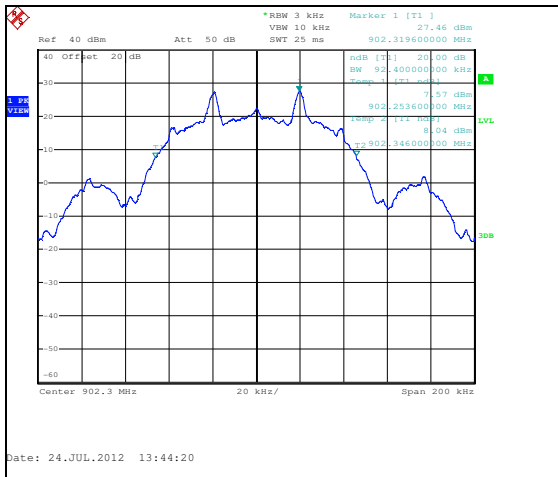

Figure 7.4.4.2-3: 20dB BW Low Channel - 38.4kbps

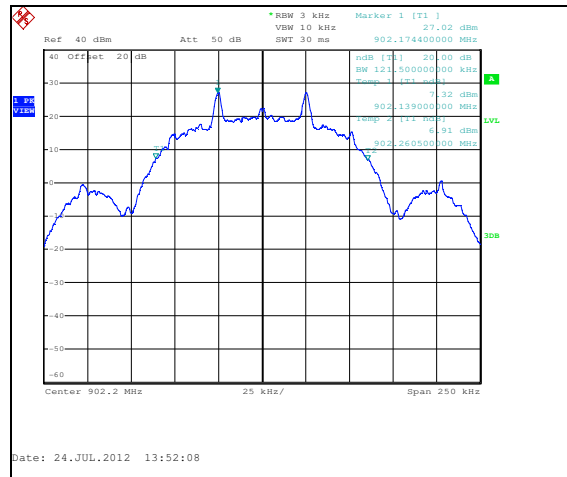

Figure 7.4.4.2-4: 20dB BW Low Channel - 50.0kbps

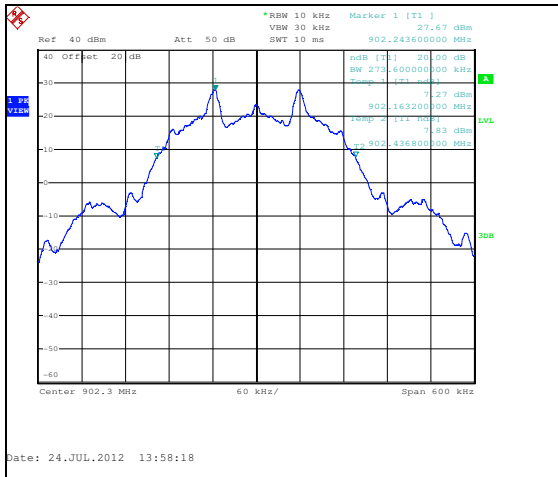

Figure 7.4.4.2-5: 20dB BW Low Channel - 115.2kbps

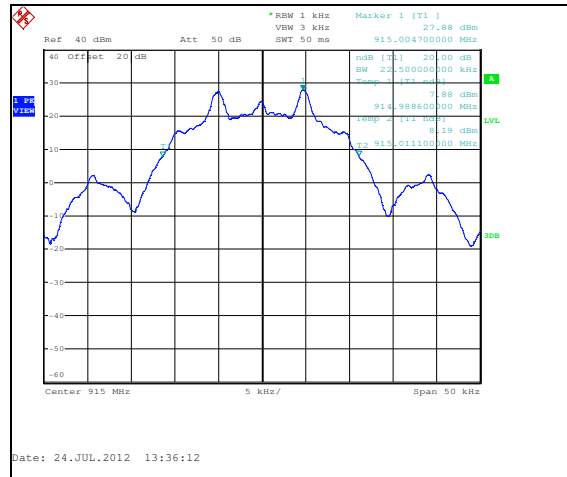

Figure 7.4.4.2-6: 20dB BW Mid Channel - 9.6kbps



Figure 7.4.4.2-7: 20dB BW Mid Channel – 19.2kbps

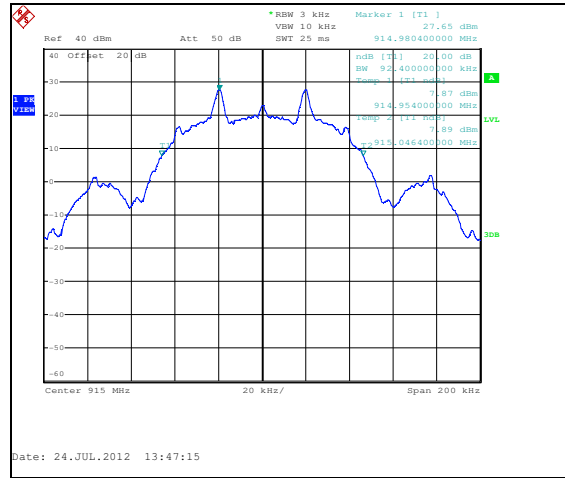

Figure 7.4.4.2-8: 20dB BW Mid Channel – 38.4kbps

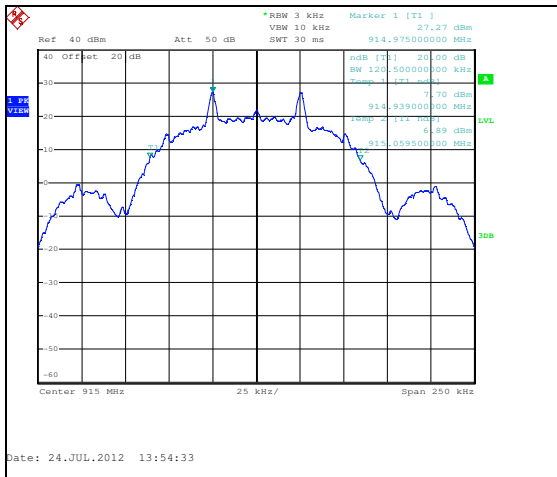

Figure 7.4.4.2-9: 20dB BW Mid Channel – 50.0kbps

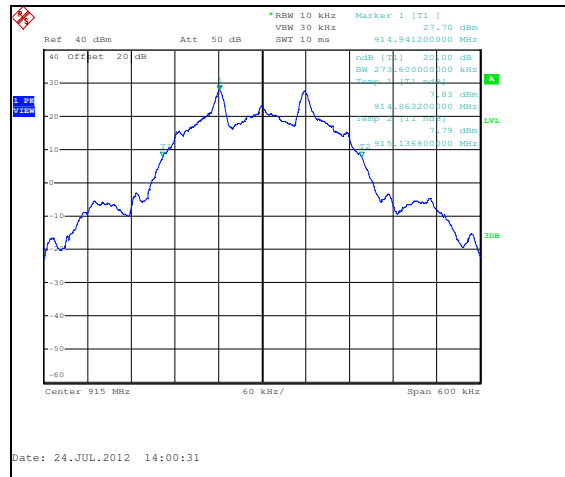

Figure 7.4.4.2-10: 20dB BW Mid Channel – 115.2kbps

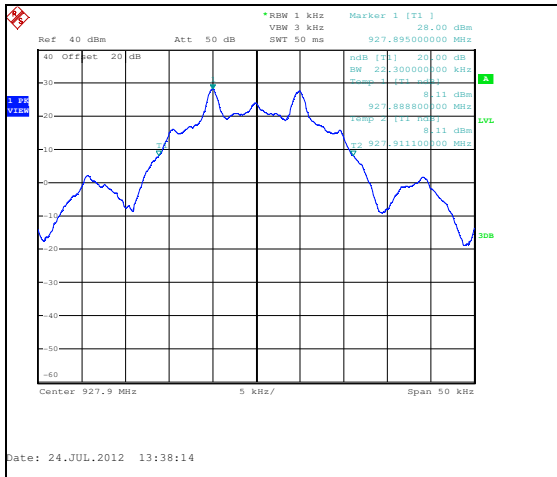

Figure 7.4.4.2-11: 20dB BW High Channel - 9.6kbps

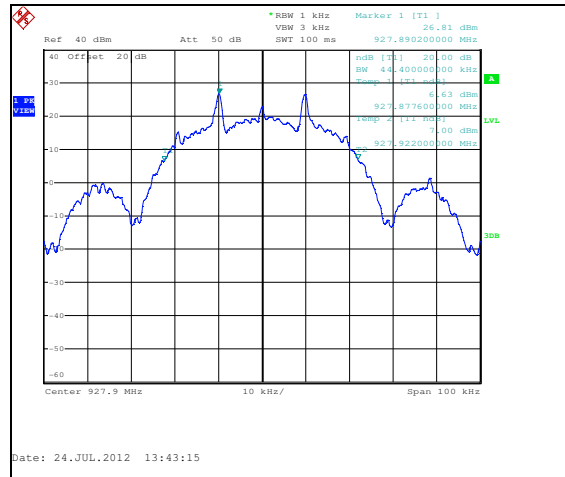
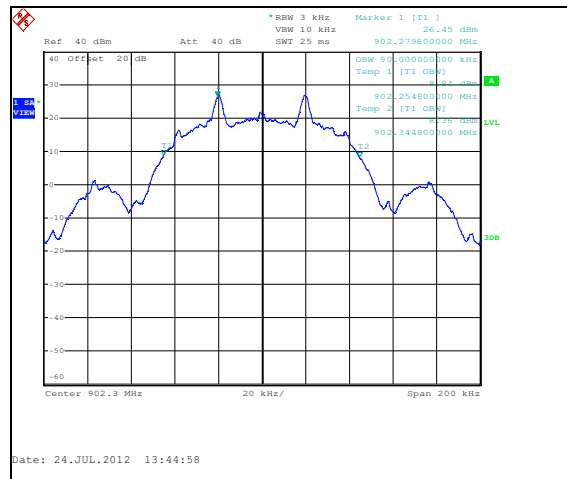
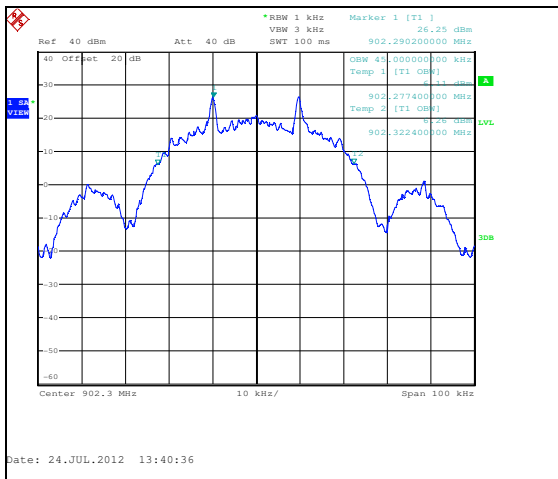
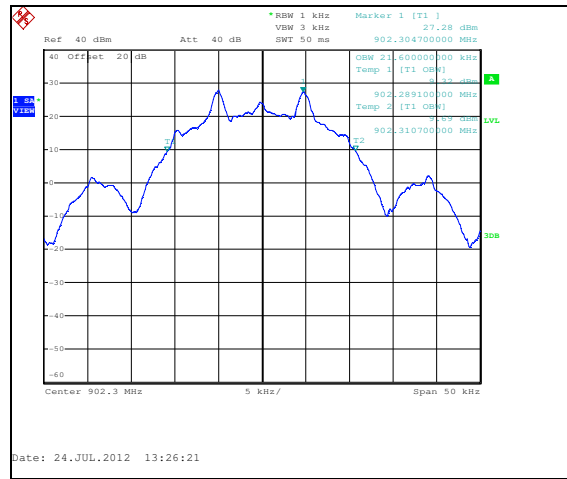
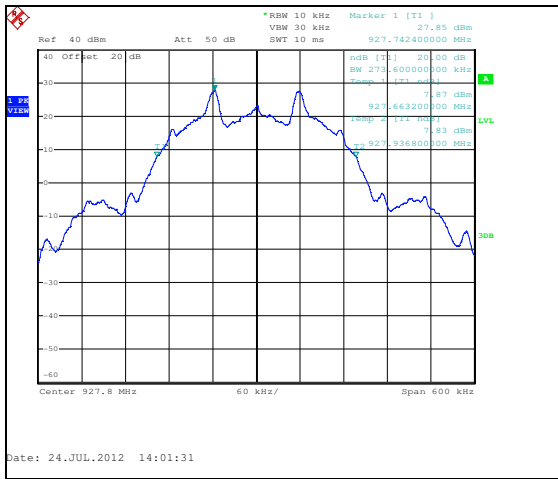
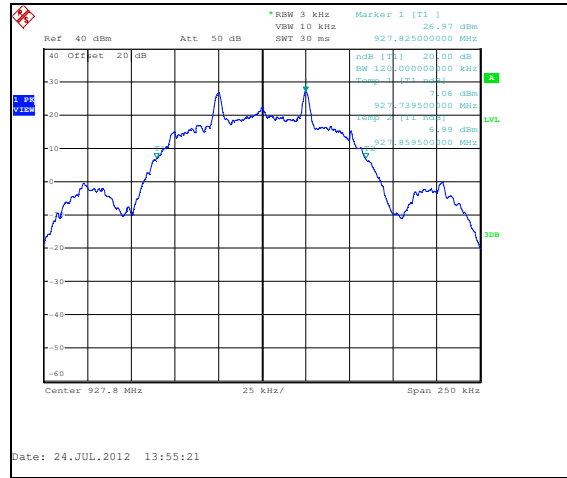
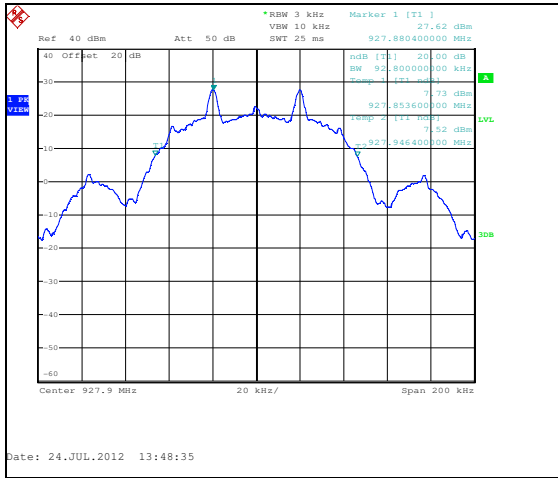

Figure 7.4.4.2-12: 20dB BW High Channel – 19.2kbps



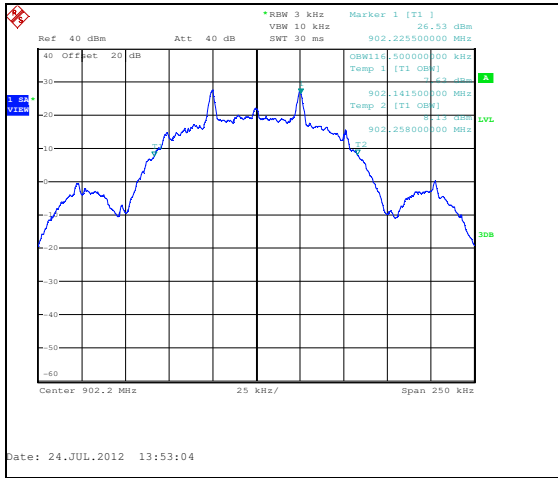

Figure 7.4.4.2-19: 99% BW Low Channel – 50.0kbps

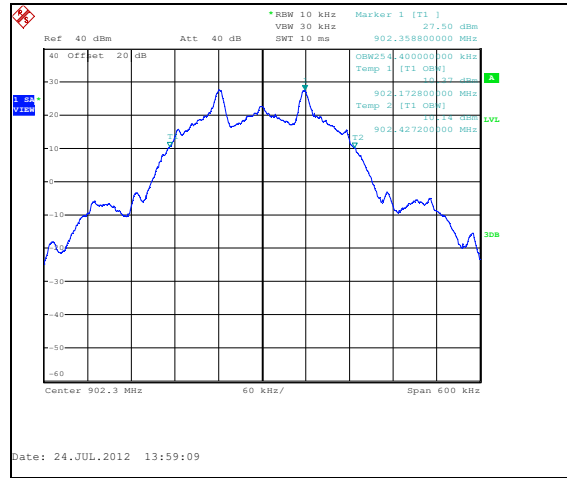

Figure 7.4.4.2-20: 99% BW Low Channel – 115.2kbps

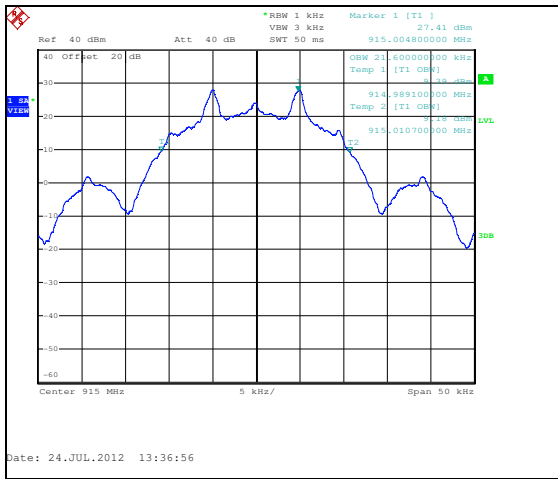

Figure 7.4.4.2-21: 99% BW Mid Channel – 9.6kbps



Figure 7.4.4.2-22: 99% BW Mid Channel – 19.2kbps

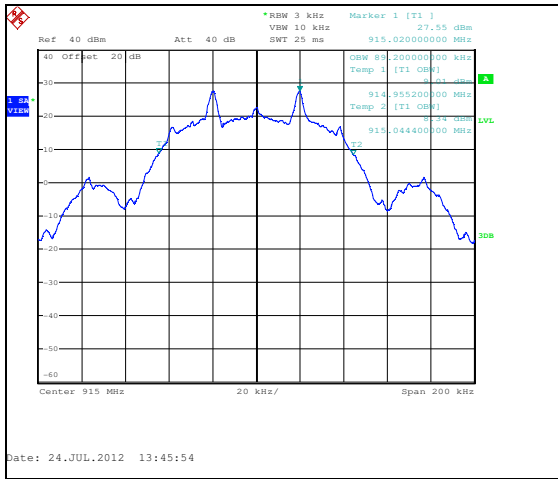

Figure 7.4.4.2-23: 99% BW Mid Channel – 38.4kbps

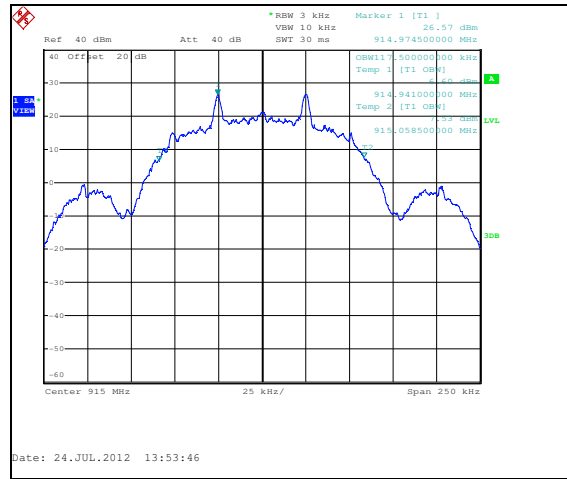

Figure 7.4.4.2-24: 99% BW Mid Channel – 50.0kbps

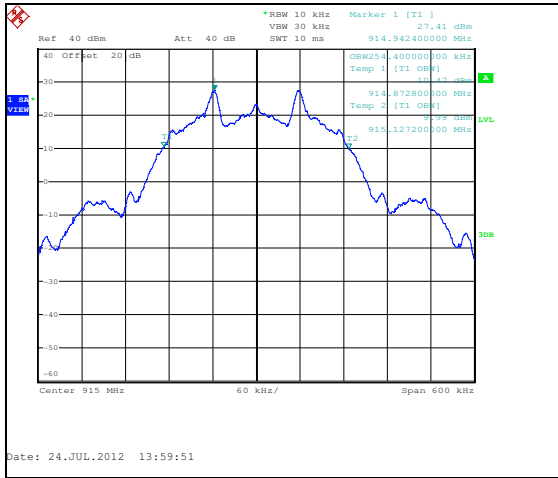

Figure 7.4.4.2-25: 99% BW Mid Channel – 115.2kbps

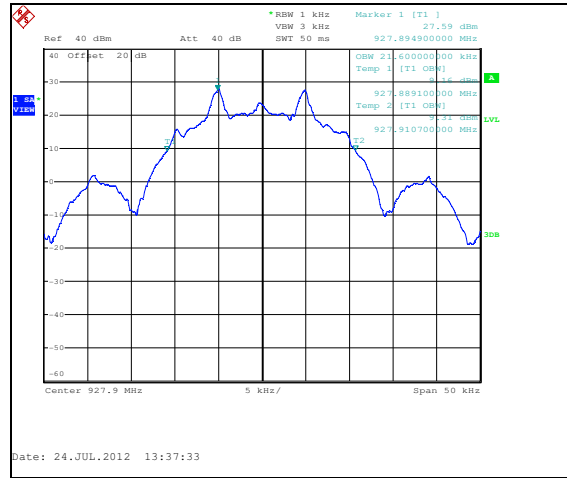

Figure 7.4.4.2-26: 99% BW High Channel – 9.6kbps

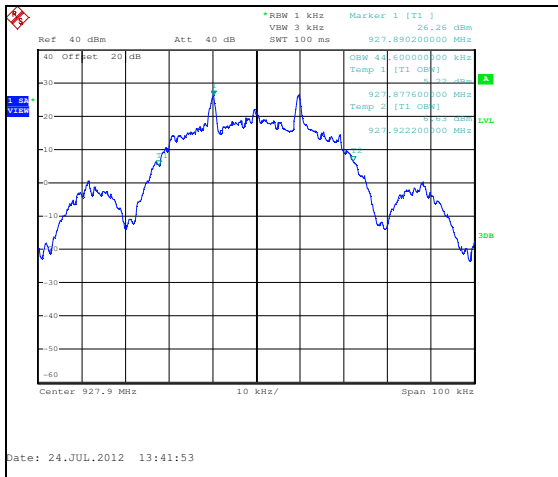

Figure 7.4.4.2-27: 99% BW High Channel – 19.2kbps

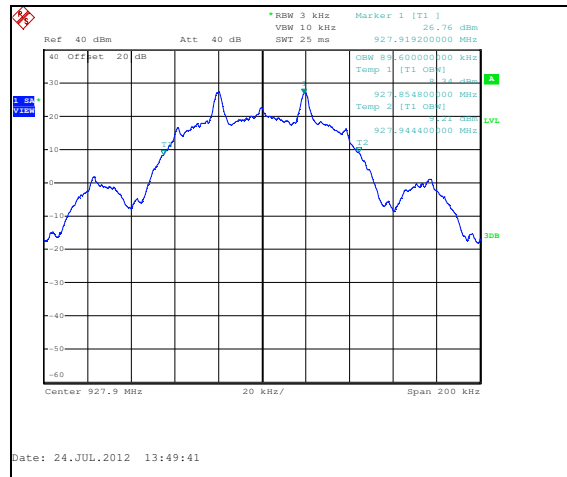

Figure 7.4.4.2-28: 99% BW High Channel – 38.4kbps

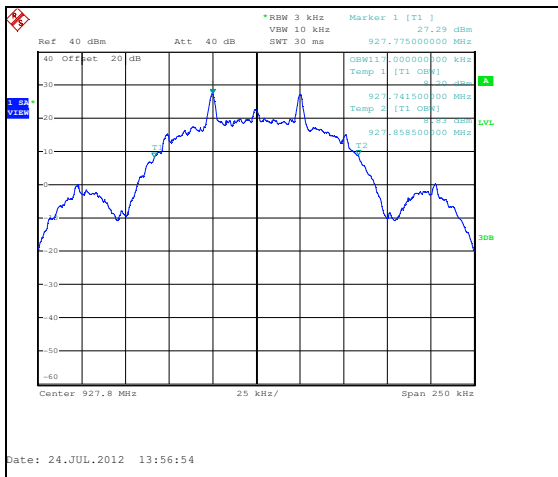

Figure 7.4.4.2-29: 99% BW High Channel – 50.0kbps

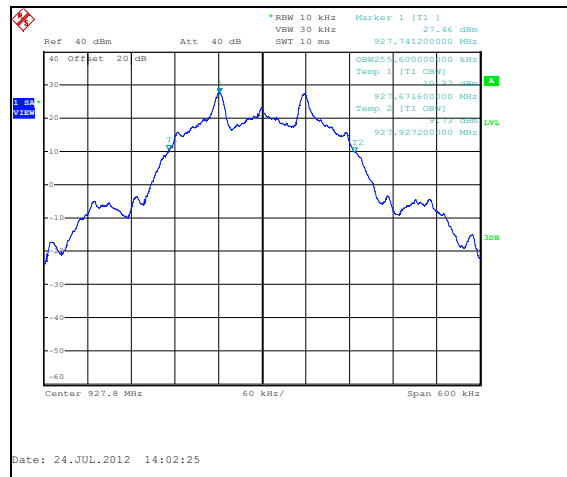

Figure 7.4.4.2-30: 99% BW High Channel – 115.2kbps

7.5 Band-Edge Compliance and Spurious Emissions-FCC 15.247(d) IC: RSS-210 A8.5

7.5.1 Band-Edge Compliance of RF Conducted Emissions

7.5.1.1 Measurement Procedure

The RF output port of the EUT was directly connected to the input of the spectrum analyzer. The EUT was investigated at the lowest and highest channel available to determine band-edge compliance. For each measurement the spectrum analyzer's RBW was set to 30 kHz, which is $\geq 1\%$ of the span, and the VBW was set to 100kHz.

Band-edge was evaluated for all combinations of operating modes and data rates with worst case data provided. Worst case reported utilized 38.4kbps in Narrow Mode, 50.0kbps in Sun Mode, and 115.2kbps in Wide Mode.

7.5.1.2 Measurement Results

Results are shown in the figures 7.5.1.2-1 to 7.5.1.2-8 below.

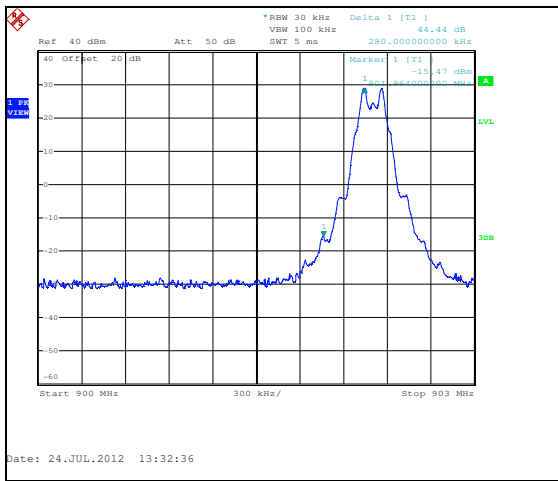

Figure 7.5.1.2-1: Lower Band-edge – Wide Mode

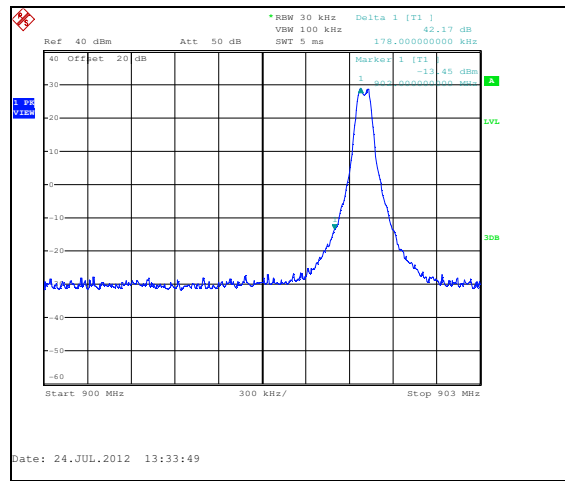

Figure 7.5.1.2-2: Lower Band-edge – SUN Mode

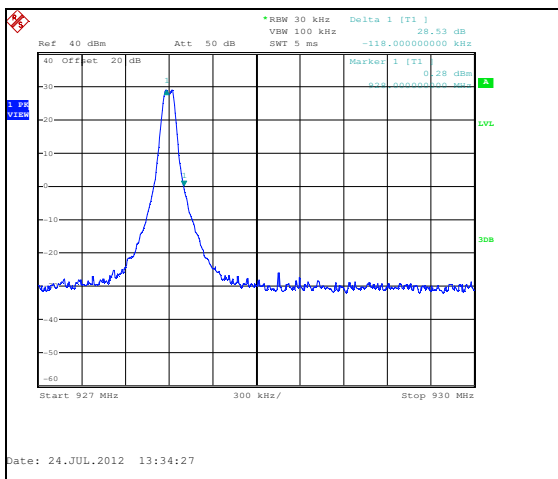

Figure 7.5.1.2-3: Upper Band-edge - Narrow Mode

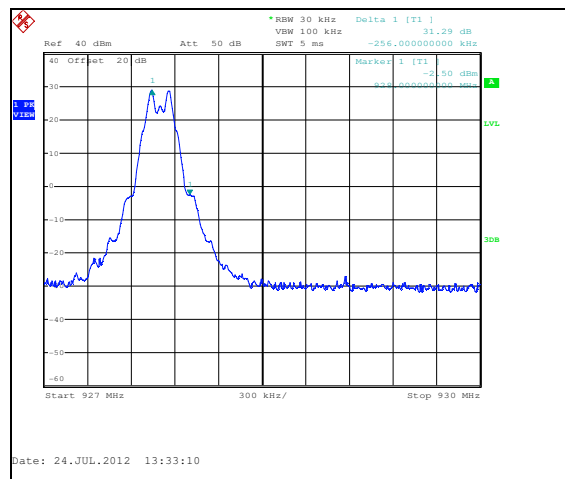

Figure 7.5.1.2-4: Upper Band-edge - Wide Mode

HOPPING MODE:

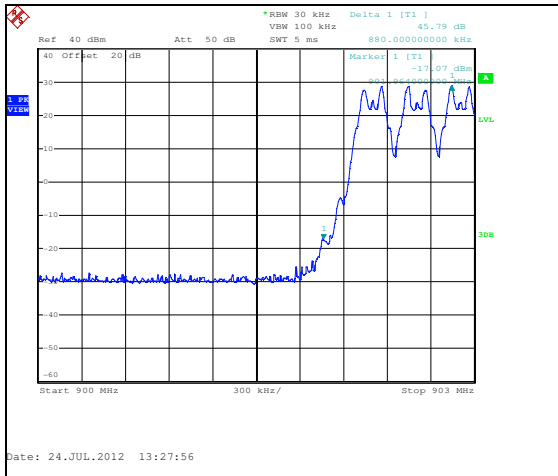

Figure 7.5.1.2-5: Lower Band-edge – Wide Mode

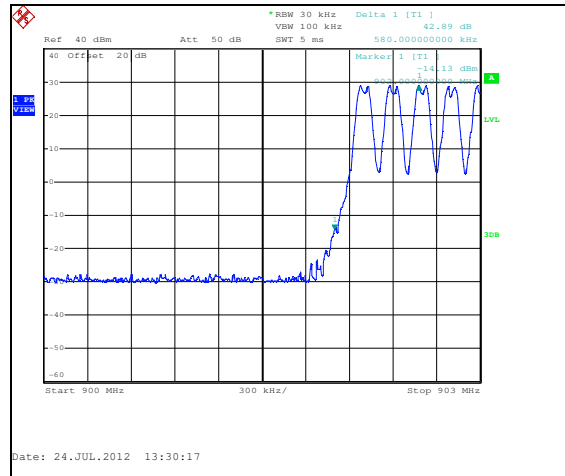

Figure 7.5.1.2-6: Lower Band-edge – SUN Mode

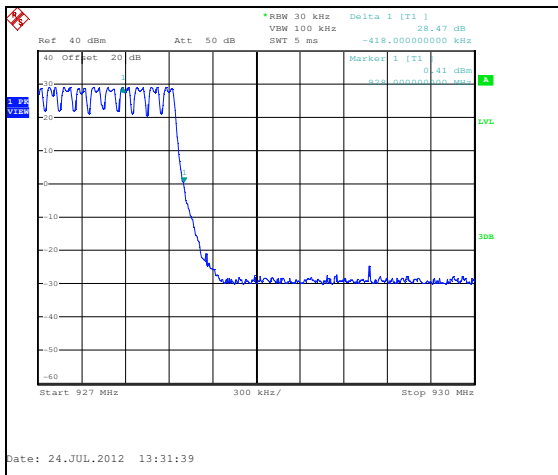

Figure 7.5.1.2-7: Upper Band-edge – Narrow Mode

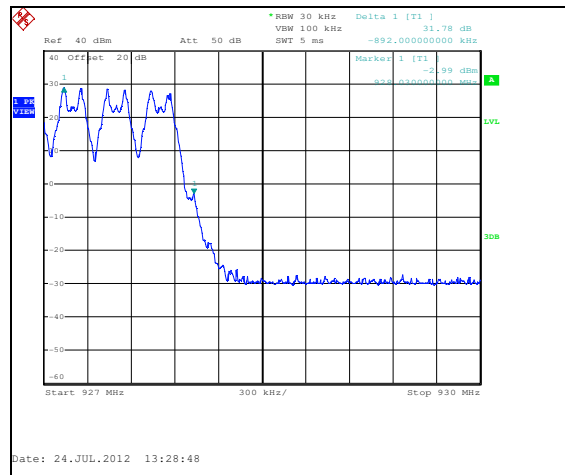

Figure 7.5.1.2-8: Upper Band-edge –Wide Mode

7.5.2 RF Conducted Spurious Emissions

7.5.2.1 Measurement Procedure

The RF output port of the EUT was directly connected to the input of the spectrum analyzer. The EUT was investigated for conducted spurious emissions from 30MHz to 10GHz, 10 times the highest fundamental frequency. Measurements were made at the low, center and high channels of the EUT. For each measurement, the spectrum analyzer's RBW was set to 100kHz. A peak detector function was used with the trace set to max hold.

RF conducted spurious emissions were evaluated for all combinations of operating modes and data rates with worst case data provided. Worst case report utilized 9.6kbps in Narrow Mode.

7.5.2.2 Measurement Results

Results are shown below in Figures 7.5.2.2-1 to 7.5.2.2-6:

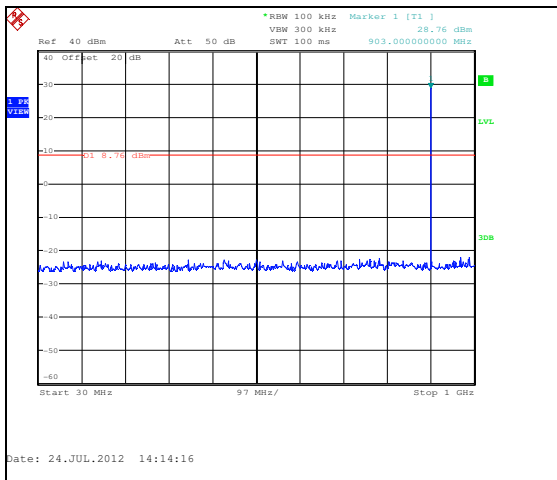

Figure 7.5.2.2-1: 30 MHz – 1 GHz – Low Channel

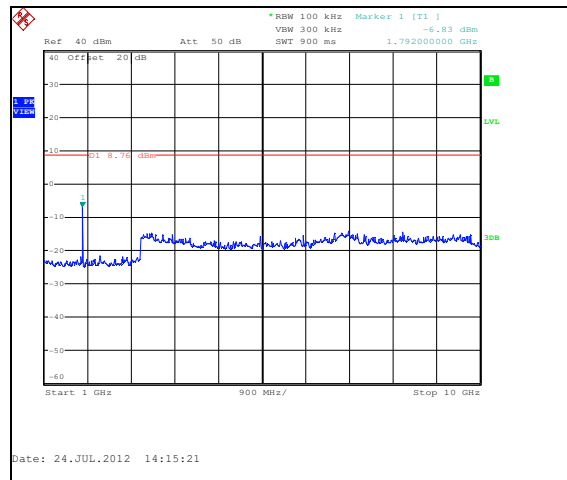

Figure 7.5.2.2-2: 1 GHz – 10 GHz – Low Channel

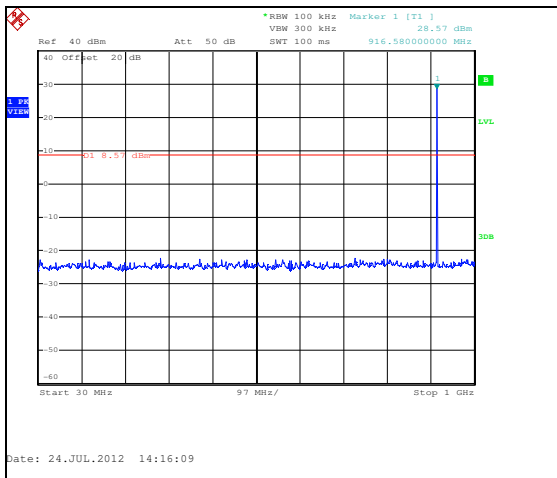

Figure 7.5.2.2-3: 30 MHz – 1 GHz –Mid Channel

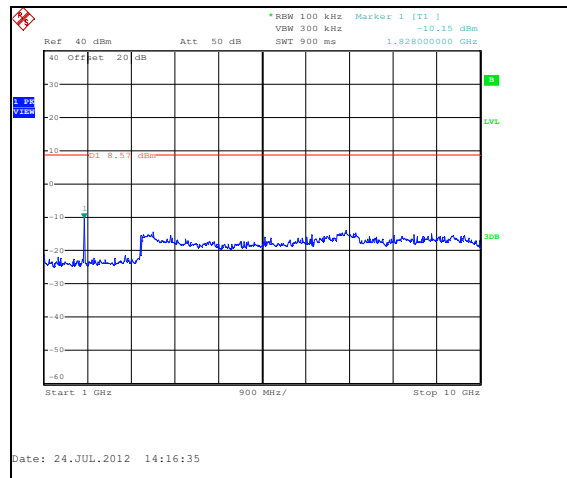

Figure 7.5.2.2-4: 1 GHz – 10 GHz – Mid Channel

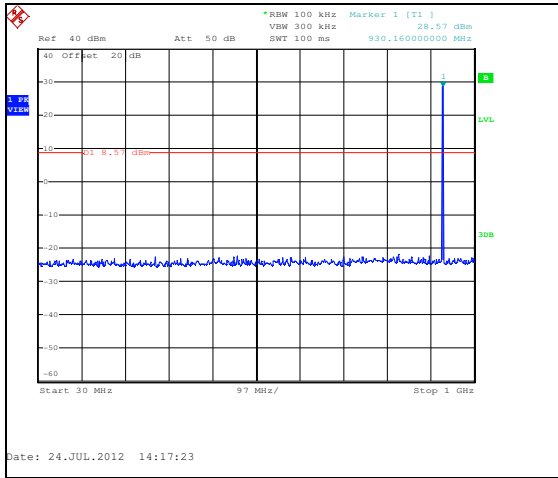

Figure 7.5.2.2-5: 30 MHz – 1 GHz – High Channel

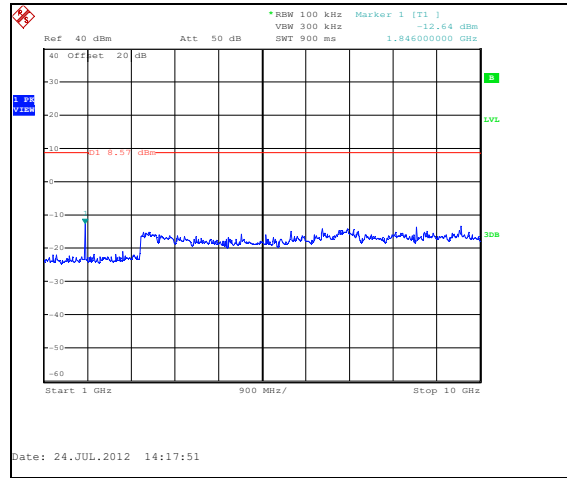

Figure 7.5.2.2-6: 1 GHz – 10 GHz – High Channel

7.5.3 Radiated Spurious Emissions - FCC Section 15.205 IC: RSS-210 2.6

7.5.3.1 Measurement Procedure

Radiated emissions tests were made over the frequency range of 30MHz to 10GHz, 10 times the highest fundamental frequency.

The EUT was rotated through 360° and the receive antenna height was varied from 1m to 4m so that the maximum radiated emissions level would be detected. For frequencies below 1000MHz, quasi-peak measurements were made using a resolution bandwidth RBW of 120 kHz and a video bandwidth VBW of 300 kHz. For frequencies above 1000MHz, peak and average measurements were made with RBW and VBW of 1 MHz and 3MHz respectively.

The EUT was caused to generate a continuous modulated carrier on the hopping channel.

Each emission found to be in a restricted band was compared to the applicable radiated emission limits.

Radiated spurious emissions were evaluated for all combinations of operating modes and data rates with worst case data provided. Worst case reported was 9.6kbps. Radiated spurious emissions were also evaluated for both antenna types and PCB variants. The EUT was positioned in multiple orientations.

7.5.3.2 Measurement Results

Radiated spurious emissions found in the band of 30MHz to 10GHz are reported in the Tables 7.3.2-1 to 7.3.2-6 below.

Table 7.3.2-1: Radiated Spurious Emissions Tabulated Data – External Antenna X-Position

Frequency (MHz)	Level (dBuV)		Antenna Polarity (H/V)	Correction Factors (dB)	Corrected Level (dBuV/m)		Limit (dBuV/m)		Margin (dB)	
	pk	Qpk/Avg			pk	Qpk/Avg	pk	Qpk/Avg	pk	Qpk/Avg
Low Channel										
960	-----	33.98	H	1.40	-----	35.38	-----	54.0	-----	18.6
960	-----	40.77	V	1.40	-----	42.17	-----	54.0	-----	11.8
966.28	-----	33.89	H	1.34	-----	35.23	-----	54.0	-----	18.8
966.28	-----	41.79	V	1.34	-----	43.13	-----	54.0	-----	10.9
998.38	-----	31.17	H	3.32	-----	34.49	-----	54.0	-----	19.5
998.38	-----	36.84	V	3.32	-----	40.16	-----	54.0	-----	13.8
2706.3	52.54	47.65	H	-3.81	48.73	43.84	74.0	54.0	25.3	10.2
2706.3	53.74	49.63	V	-3.81	49.93	45.82	74.0	54.0	24.1	8.2
Middle Channel										
979.18	-----	32.75	H	1.85	-----	34.60	-----	54.0	-----	19.4
979.18	-----	39.05	V	1.85	-----	40.90	-----	54.0	-----	13.1
2745	51.77	46.07	H	-3.74	48.03	42.33	74.0	54.0	26.0	11.7
2745	56.28	53.39	V	-3.74	52.54	49.65	74.0	54.0	21.5	4.3
High Channel										
960	-----	33.77	H	1.40	-----	35.17	-----	54.0	-----	18.8
960	-----	38.95	V	1.40	-----	40.35	-----	54.0	-----	13.7
992.11	-----	30.36	H	2.63	-----	32.99	-----	54.0	-----	21.0
992.11	-----	33.22	V	2.63	-----	35.85	-----	54.0	-----	18.1
998.16	-----	27.55	H	3.30	-----	30.85	-----	54.0	-----	23.2
998.16	-----	28.87	V	3.30	-----	32.17	-----	54.0	-----	21.8
2783.7	51.41	46.13	H	-3.67	47.74	42.46	74.0	54.0	26.3	11.5
2783.7	55.62	52.55	V	-3.67	51.95	48.88	74.0	54.0	22.0	5.1
7423.2	46.36	37.11	H	7.82	54.18	44.93	74.0	54.0	19.8	9.1
7423.2	47.38	37.24	V	7.82	55.20	45.06	74.0	54.0	18.8	8.9

Table 7.3.2-2: Radiated Spurious Emissions Tabulated Data – External Antenna Y-Position

Frequency (MHz)	Level (dBuV)		Antenna Polarity (H/V)	Correction Factors (dB)	Corrected Level (dBuV/m)		Limit (dBuV/m)		Margin (dB)	
	pk	Qpk/Avg			pk	Qpk/Avg	pk	Qpk/Avg	pk	Qpk/Avg
Low Channel										
960	-----	31.73	H	1.40	-----	33.13	-----	54.0	-----	20.9
960	-----	29.56	V	1.40	-----	30.96	-----	54.0	-----	23.0
966.28	-----	32.54	H	1.34	-----	33.88	-----	54.0	-----	20.1
966.28	-----	29.52	V	1.34	-----	30.86	-----	54.0	-----	23.1
998.38	-----	30.11	H	3.32	-----	33.43	-----	54.0	-----	20.6
998.38	-----	27.80	V	3.32	-----	31.12	-----	54.0	-----	22.9
2706.3	50.63	44.37	H	-3.81	46.82	40.56	74.0	54.0	27.2	13.4
2706.3	54.23	50.42	V	-3.81	50.42	46.61	74.0	54.0	23.6	7.4
Middle Channel										
979.18	-----	32.24	H	1.85	-----	34.09	-----	54.0	-----	19.9
979.18	-----	39.89	V	1.85	-----	41.74	-----	54.0	-----	12.3
2745	49.16	41.33	H	-3.74	45.42	37.59	74.0	54.0	28.6	16.4
2745	52.51	47.83	V	-3.74	48.77	44.09	74.0	54.0	25.2	9.9
High Channel										
960	-----	35.31	H	1.40	-----	36.71	-----	54.0	-----	17.3
960	-----	37.24	V	1.40	-----	38.64	-----	54.0	-----	15.4
992.08	-----	31.81	H	2.63	-----	34.44	-----	54.0	-----	19.6
992.08	-----	31.60	V	2.63	-----	34.23	-----	54.0	-----	19.8
998	-----	28.28	H	3.28	-----	31.56	-----	54.0	-----	22.4
998	-----	27.85	V	3.28	-----	31.13	-----	54.0	-----	22.9
2783.7	51.56	46.18	H	-3.67	47.89	42.51	74.0	54.0	26.1	11.5
2783.7	54.89	51.41	V	-3.67	51.22	47.74	74.0	54.0	22.8	6.3

Table 7.3.2-3: Radiated Spurious Emissions Tabulated Data – External Antenna Z-Position

Frequency (MHz)	Level (dBuV)		Antenna Polarity (H/V)	Correction Factors (dB)	Corrected Level (dBuV/m)		Limit (dBuV/m)		Margin (dB)	
	pk	Qpk/Avg			pk	Qpk/Avg	pk	Qpk/Avg	pk	Qpk/Avg
Low Channel										
960	-----	32.37	H	1.40	-----	33.77	-----	54.0	-----	20.2
960	-----	29.55	V	1.40	-----	30.95	-----	54.0	-----	23.1
966.28	-----	33.77	H	1.34	-----	35.11	-----	54.0	-----	18.9
966.28	-----	30.54	V	1.34	-----	31.88	-----	54.0	-----	22.1
998.38	-----	29.91	H	3.32	-----	33.23	-----	54.0	-----	20.8
998.38	-----	21.04	V	3.32	-----	24.36	-----	54.0	-----	29.6
2706.3	50.27	43.13	H	-3.81	46.46	39.32	74.0	54.0	27.5	14.7
2706.3	54.20	50.72	V	-3.81	50.39	46.91	74.0	54.0	23.6	7.1
Middle Channel										
979.18	-----	32.09	H	1.85	-----	33.94	-----	54.0	-----	20.1
979.18	-----	39.76	V	1.85	-----	41.61	-----	54.0	-----	12.4
2745	49.27	42.14	H	-3.74	45.53	38.40	74.0	54.0	28.5	15.6
2745	53.44	49.42	V	-3.74	49.70	45.68	74.0	54.0	24.3	8.3
High Channel										
960	-----	34.05	H	1.40	-----	35.45	-----	54.0	-----	18.6
960	-----	39.38	V	1.40	-----	40.78	-----	54.0	-----	13.2
992.08	-----	30.72	H	2.63	-----	33.35	-----	54.0	-----	20.7
992.08	-----	32.95	V	2.63	-----	35.58	-----	54.0	-----	18.4
998	-----	28.36	H	3.28	-----	31.64	-----	54.0	-----	22.4
998	-----	29.32	V	3.28	-----	32.60	-----	54.0	-----	21.4
2783.7	50.68	44.81	H	-3.67	47.01	41.14	74.0	54.0	27.0	12.9
2783.7	55.24	52.17	V	-3.67	51.57	48.50	74.0	54.0	22.4	5.5

Table 7.3.2-4: Radiated Spurious Emissions Tabulated Data – Internal Antenna X-Position

Frequency (MHz)	Level (dBuV)		Antenna Polarity (H/V)	Correction Factors (dB)	Corrected Level (dBuV/m)		Limit (dBuV/m)		Margin (dB)	
	pk	Qpk/Avg			pk	Qpk/Avg	pk	Qpk/Avg	pk	Qpk/Avg
Low Channel										
960	-----	27.29	H	1.40	-----	28.69	-----	54.0	-----	25.3
960	-----	26.20	V	1.40	-----	27.60	-----	54.0	-----	26.4
966	-----	26.42	H	1.34	-----	27.76	-----	54.0	-----	26.2
966	-----	25.94	V	1.34	-----	27.28	-----	54.0	-----	26.7
2706.3	56.44	53.67	H	-3.81	52.63	49.86	74.0	54.0	21.4	4.1
2706.3	51.61	45.31	V	-3.81	47.80	41.50	74.0	54.0	26.2	12.5
Middle Channel										
979.18	-----	28.81	H	1.85	-----	30.66	-----	54.0	-----	23.3
979.18	-----	27.06	V	1.85	-----	28.91	-----	54.0	-----	25.1
2745	57.98	55.65	H	-3.74	54.24	51.91	74.0	54.0	19.8	2.1
2745	55.17	51.92	V	-3.74	51.43	48.18	74.0	54.0	22.6	5.8
4575	49.20	41.15	H	1.85	51.05	43.00	74.0	54.0	23.0	11.0
4575	48.53	39.04	V	1.85	50.38	40.89	74.0	54.0	23.6	13.1
High Channel										
960	-----	34.58	H	1.40	-----	35.98	-----	54.0	-----	18.0
960	-----	30.54	V	1.40	-----	31.94	-----	54.0	-----	22.1
966	-----	28.61	H	1.34	-----	29.95	-----	54.0	-----	24.1
966	-----	26.42	V	1.34	-----	27.76	-----	54.0	-----	26.2
992.08	-----	28.18	H	2.63	-----	30.81	-----	54.0	-----	23.2
992.08	-----	26.50	V	2.63	-----	29.13	-----	54.0	-----	24.9
2783.7	55.12	51.84	H	-3.67	51.45	48.17	74.0	54.0	22.5	5.8
2783.7	56.17	53.24	V	-3.67	52.50	49.57	74.0	54.0	21.5	4.4
4639.5	48.68	40.03	H	1.95	50.63	41.98	74.0	54.0	23.4	12.0
4639.5	49.13	41.38	V	1.95	51.08	43.33	74.0	54.0	22.9	10.7

Table 7.3.2-5: Radiated Spurious Emissions Tabulated Data – Internal Antenna Y-Position

Frequency (MHz)	Level (dBuV)		Antenna Polarity (H/V)	Correction Factors (dB)	Corrected Level (dBuV/m)		Limit (dBuV/m)		Margin (dB)	
	pk	Qpk/Avg			pk	Qpk/Avg	pk	Qpk/Avg	pk	Qpk/Avg
Low Channel										
960	-----	29.61	H	1.40	-----	31.01	-----	54.0	-----	23.0
960	-----	29.80	V	1.40	-----	31.20	-----	54.0	-----	22.8
966.28	-----	27.97	H	1.34	-----	29.31	-----	54.0	-----	24.7
966.28	-----	28.68	V	1.34	-----	30.02	-----	54.0	-----	24.0
998.38	-----	25.43	H	3.32	-----	28.75	-----	54.0	-----	25.2
998.38	-----	27.39	V	3.32	-----	30.71	-----	54.0	-----	23.3
2706.3	55.24	51.87	H	-3.81	51.43	48.06	74.0	54.0	22.6	5.9
2706.3	57.30	54.76	V	-3.81	53.49	50.95	74.0	54.0	20.5	3.1
3608.4	49.48	41.12	H	-0.41	49.07	40.71	74.0	54.0	24.9	13.3
4510.5	49.11	39.30	V	1.74	50.85	41.04	74.0	54.0	23.1	13.0
Middle Channel										
979.18	-----	31.07	H	1.85	-----	32.92	-----	54.0	-----	21.1
979.18	-----	30.82	V	1.85	-----	32.67	-----	54.0	-----	21.3
2745	51.86	46.38	H	-3.74	48.12	42.64	74.0	54.0	25.9	11.4
2745	57.53	55.14	V	-3.74	53.79	51.40	74.0	54.0	20.2	2.6
3660	50.68	42.39	H	-0.18	50.50	42.21	74.0	54.0	23.5	11.8
3660	50.32	42.29	V	-0.18	50.14	42.11	74.0	54.0	23.9	11.9
4575	50.11	41.83	V	1.85	51.96	43.68	74.0	54.0	22.0	10.3
High Channel										
960	-----	36.61	H	1.40	-----	38.01	-----	54.0	-----	16.0
960	-----	36.25	V	1.40	-----	37.65	-----	54.0	-----	16.4
966.28	-----	31.02	H	1.34	-----	32.36	-----	54.0	-----	21.6
966.28	-----	30.94	V	1.34	-----	32.28	-----	54.0	-----	21.7
992.08	-----	29.34	H	2.63	-----	31.97	-----	54.0	-----	22.0
992.08	-----	30.18	V	2.63	-----	32.81	-----	54.0	-----	21.2
998.38	-----	26.22	H	3.32	-----	29.54	-----	54.0	-----	24.5
998.38	-----	28.56	V	3.32	-----	31.88	-----	54.0	-----	22.1
2783.7	57.27	54.73	H	-3.67	53.60	51.06	74.0	54.0	20.4	2.9
2783.7	54.31	50.32	V	-3.67	50.64	46.65	74.0	54.0	23.4	7.3
3711.6	50.35	41.68	H	0.04	50.39	41.72	74.0	54.0	23.6	12.3
4639.5	51.31	45.47	V	1.95	53.26	47.42	74.0	54.0	20.7	6.6

Table 7.3.2-6: Radiated Spurious Emissions Tabulated Data – Internal Antenna Z-Position

Frequency (MHz)	Level (dBuV)		Antenna Polarity (H/V)	Correction Factors (dB)	Corrected Level (dBuV/m)		Limit (dBuV/m)		Margin (dB)	
	pk	Qpk/Avg			pk	Qpk/Avg	pk	Qpk/Avg	pk	Qpk/Avg
Low Channel										
2706.3	55.12	51.74	H	-3.81	51.31	47.93	74.0	54.0	22.7	6.1
2706.3	56.20	52.98	V	-3.81	52.39	49.17	74.0	54.0	21.6	4.8
3608.4	50.15	41.96	H	-0.41	49.74	41.55	74.0	54.0	24.3	12.4
Middle Channel										
979.18	-----	27.67	V	1.85	-----	29.52	-----	54.0	-----	24.5
2745	53.46	48.72	H	-3.74	49.72	44.98	74.0	54.0	24.3	9.0
2745	53.92	50.24	V	-3.74	50.18	46.50	74.0	54.0	23.8	7.5
3660	50.11	40.62	H	-0.18	49.93	40.44	74.0	54.0	24.1	13.6
High Channel										
960	-----	29.37	H	1.40	-----	30.77	-----	54.0	-----	23.2
960	-----	30.36	V	1.40	-----	31.76	-----	54.0	-----	22.2
966	-----	26.83	H	1.34	-----	28.17	-----	54.0	-----	25.8
966	-----	28.23	V	1.34	-----	29.57	-----	54.0	-----	24.4
2783.7	53.77	49.79	H	-3.67	50.10	46.12	74.0	54.0	23.9	7.9
2783.7	53.16	48.54	V	-3.67	49.49	44.87	74.0	54.0	24.5	9.1
3711.6	50.38	41.68	H	0.04	50.42	41.72	74.0	54.0	23.6	12.3

7.5.3.3 Sample Calculation:

$$R_C = R_U + CF_T$$

Where:

- CF_T = Total Correction Factor (AF+CA+AG)-DC (Average Measurements Only)
- R_U = Uncorrected Reading
- R_C = Corrected Level
- AF = Antenna Factor
- CA = Cable Attenuation
- AG = Amplifier Gain
- DC = Duty Cycle Correction Factor

Example Calculation: Peak

Corrected Level: $52.54 - 3.81 = 48.73\text{dBuV/m}$

Margin: $74\text{dBuV/m} - 48.73\text{dBuV/m} = 25.3\text{dB}$

Example Calculation: Average

Corrected Level: $47.65 - 3.81 - 0 = 43.84\text{dBuV}$

Margin: $54\text{dBuV} - 43.84\text{dBuV} = 10.2\text{dB}$

8 CONCLUSION

In the opinion of ACS, Inc. Gridstream S4 Modular SCADA/DA, manufactured by Landis+Gyr Technology Inc. meets the requirements of FCC Part 15 subpart C and Industry Canada's Radio Standards Specification RSS-210.

END REPORT