

M225

Product FCC and IC Compliance Manual

Publication: D3831, Rev AA

© Landis+Gyr 2021 | Proprietary + Confidential

Limitation on Warranties and Liability

Information in this document is subject to change without notice. This manual or any part of it thereof may not be reproduced in any form unless permitted by contract or by written permission of Landis+Gyr.

In no event will Landis+Gyr be liable for any incidental, indirect, special, or consequential damages (including lost profits) arising out of or relating to this publication or the information contained in it, even if Landis+Gyr has been advised, knew, or should have known of the possibility of such damages.

Covered by both issued and pending patents.

For further patent information see: <https://www.landisgyr.com/about/patent-notice/>

© 2021 Landis+Gyr, Inc. | Proprietary + Confidential

Contact Us:

To provide feedback about this document, email us at ustechnicaldocumentation@landisgyr.com

Customer Support: 1-888-390-5733 | support.na@landisgyr.com

Introduction

M225 supports both single channel and frequency hopping RF communication modes. The device has a two-way communication radio that complies to FCC Part 15.247, FCC Part 15.249, and ISED Canada Radio Standards Specifications RSS-210 and RSS-247. Dimension of the board is as shown in the figure below.

The M225 module is not commercially available as a standalone product for third-party integration. It is intended for only Landis+Gyr series 5 residential gas products.

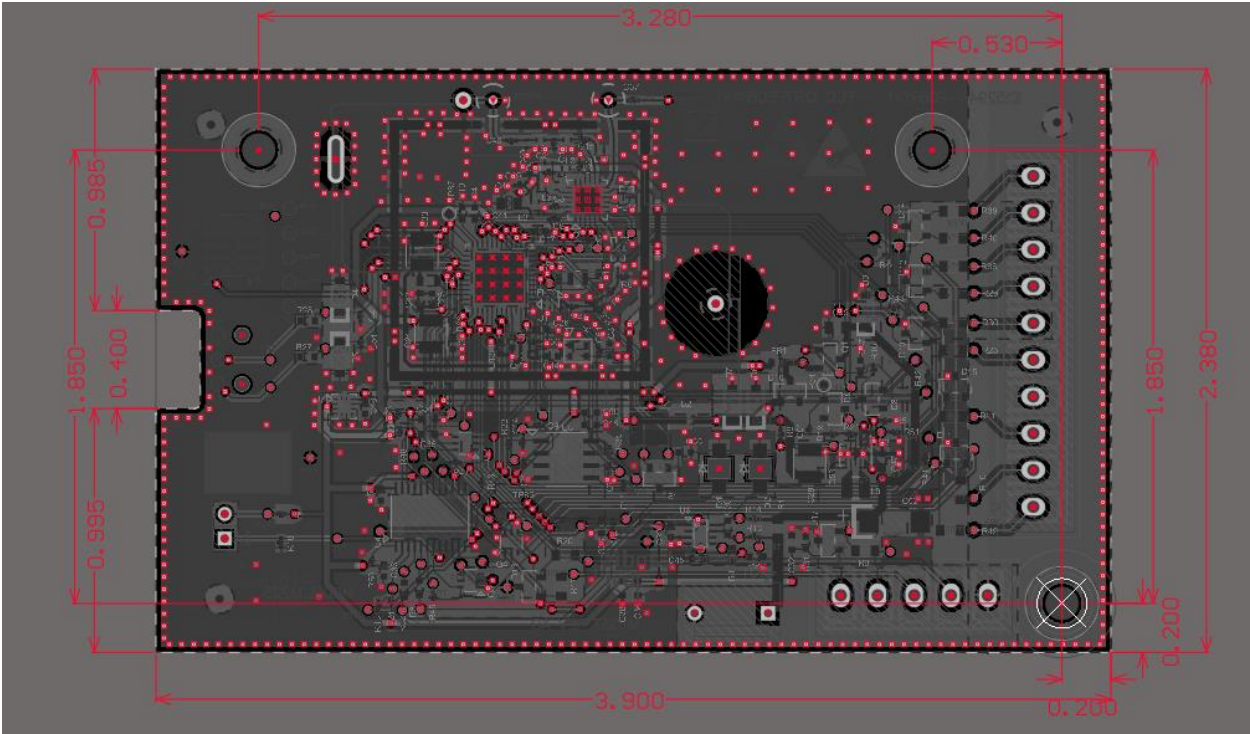
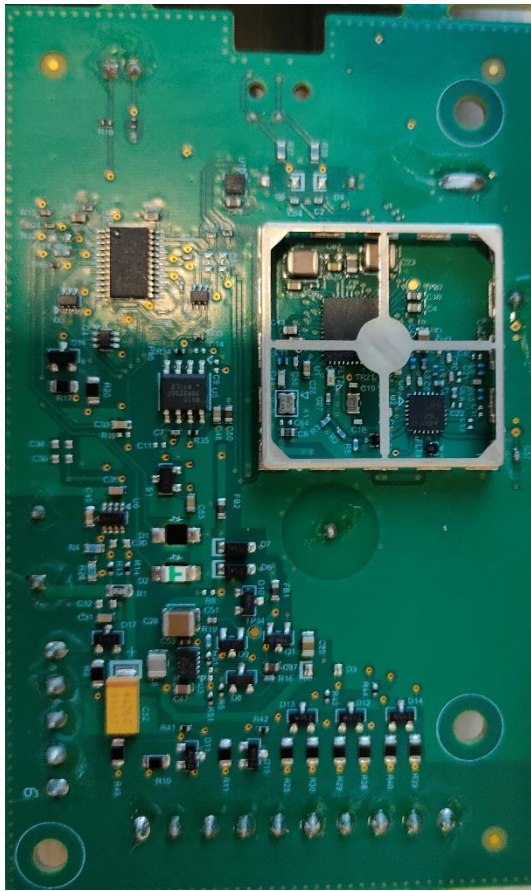
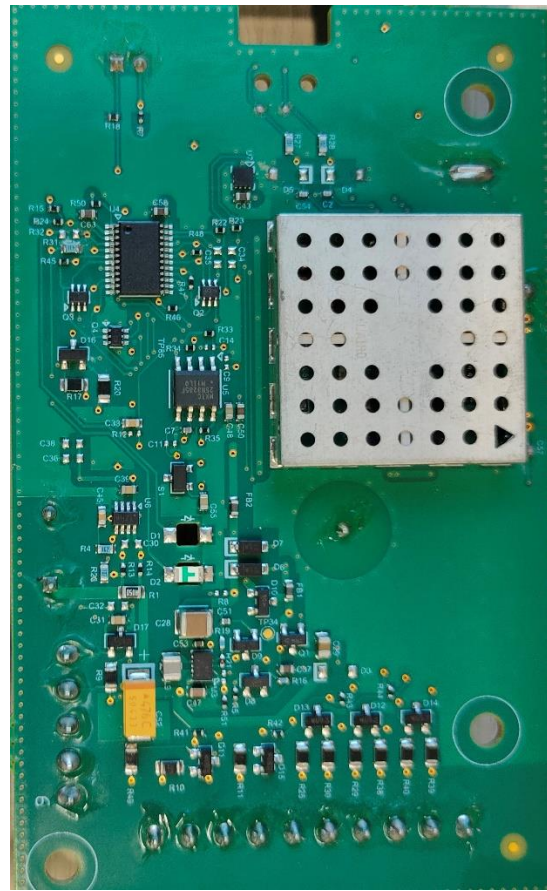

Figure 1. Board Dimension



a



b

Figure 2. a) Bottom Side with RF Shield Lid Removed and b) Bottom Side with RF Shield Lid Installed

In the figure below, the FCC ID, IC ID, and model name are shown as prints at the top of the board.

Module Model: M225
FCC ID: R7PEC6R1X1
IC ID: 5294A-EC6R1X1

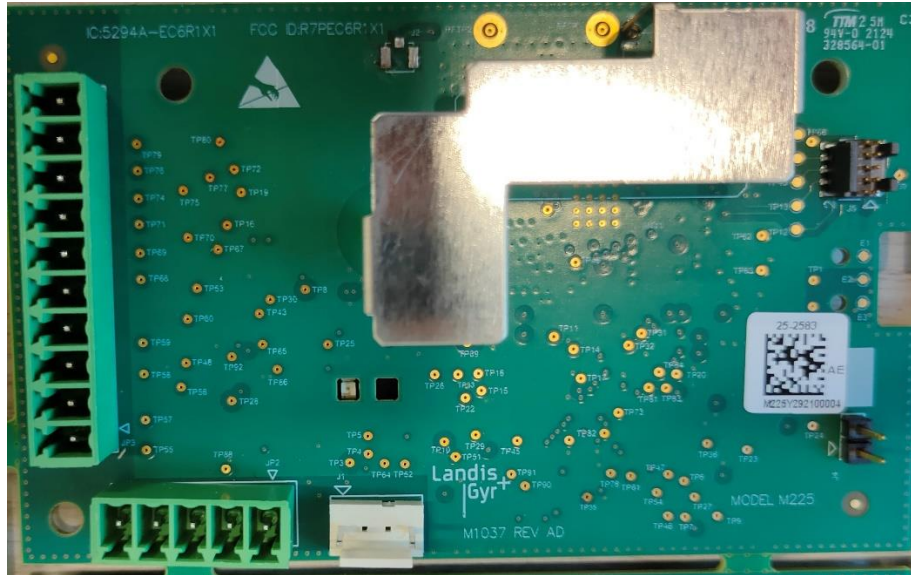

Figure 3. Top side with Antenna

Product Overview

This M225 is designed for Landis+Gyr series 5 gas product assemblies, which are assembled at a contract manufacturer. Gas products are battery operated devices.

NOTES:

1. THIS ASSEMBLY SHALL BE IN ACCORDANCE WITH DOCUMENT NUMBER 95-1690. SURFACES SHALL BE CONSIDERED "CLASS C" SURFACES UNLESS OTHERWISE SPECIFIED.
2. THIS ASSEMBLY SHALL BE IN ACCORDANCE WITH DOCUMENT NUMBER 95-1672 (TORQUE SPECIFICATION).
3. ONLY APPROVED SOURCES PER BILL OF MATERIAL TO BE USED.
4. PRIOR TO ATTACHING LABELS OR ADHESIVE PARTS, CLEAN DESIGNATED SURFACE AREAS USING DENATURATED ALCOHOL.
5. LOAD BOARD INTO ENCLOSURE AND HEAT STAKE TO THE 3 PINS AFTER THE PCB IS FIRMLY SEATED ONTO THE PINS. HEAT STAKE TEMP NOT TO EXCEED 220°C.
6. PLACE BATTERY PACK (ITEM 64) AND TAPE (ITEM 65) APPROXIMATELY IN THE CENTER OF THE ENCLOSURE DO NOT PLUG IN BATTERY.
7. TAPE (14) BARCODE BIT (13) ON THE COVER, AT THE LOCATION SHOWN TAPE SHOULD NOT COVER ANY LABEL.
8. SEE TOP-LEVEL BOM TO DETERMINE IF LABEL (23-1690) SHOULD BE POPULATED.

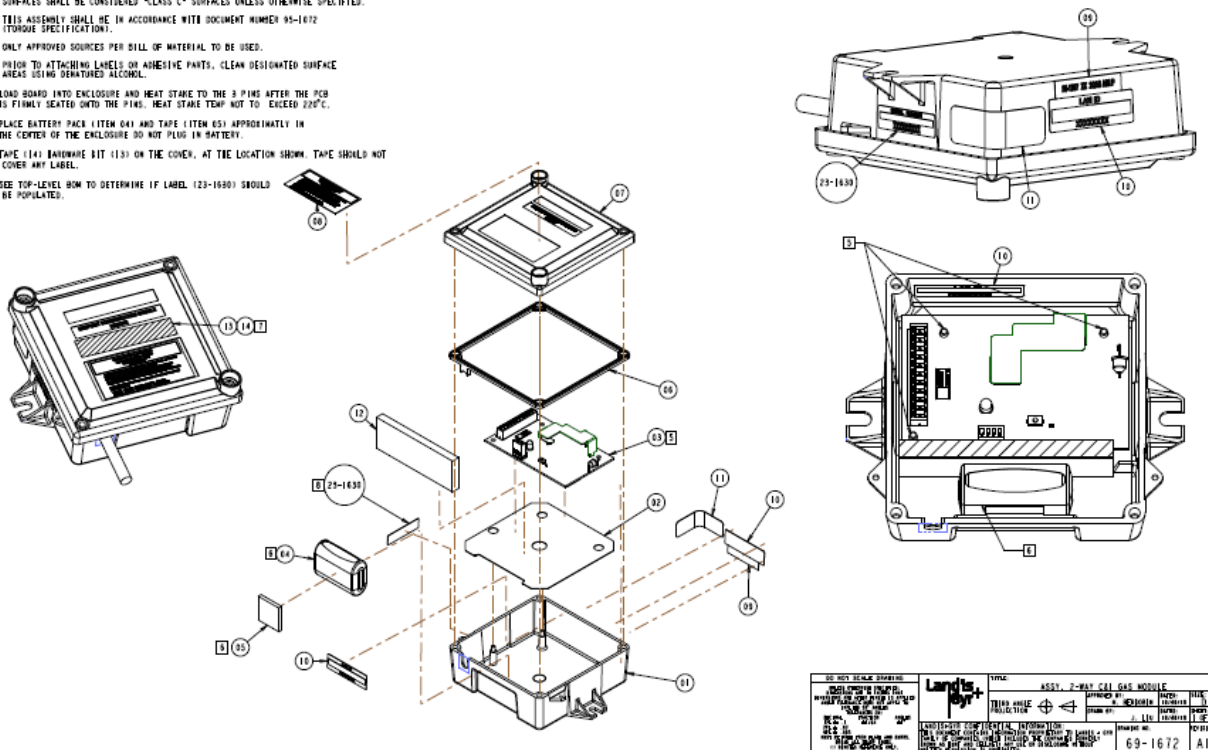

Figure 4. Products Containing the M225 PCBA

Federal Communications Commission (FCC)

Compliance Notice

This device complies with Part 15 of the FCC rules. Operation is subject to the following two conditions:

1. This device may not cause harmful interference, and
2. This device must accept any interference received, including interference that may cause undesired operation.

This equipment has been tested and found to comply with the limits for a Class B digital device, pursuant to Part 15 of the FCC Rules. These limits are designed to provide reasonable protection against harmful interference in a residential installation. This equipment generates, uses, and can radiate radio frequency energy and, if not installed and used in accordance with the instructions, may cause harmful interference to radio communications. However, there is no guarantee that interference will not occur in a particular installation. If this equipment does cause harmful interference to radio or television reception, which can be determined by turning the equipment off and on, the user is encouraged to try to correct the interference by one or more of the following measures:

- Reorient or relocate the receiving antenna.
- Increase the separation between the equipment and receiver.
- Consult Landis+Gyr or an experienced radio technician for help



WARNING: Changes or modifications to this device not expressly approved by Landis+Gyr could void the user's authority to operate the equipment.

Industry Canada (IC) Compliance Notice

This device complies with Industry Canada license-exempt RSS standard(s). Operation is subject to the following two conditions: (1) this device may not cause interference, and (2) this device must accept any interference, including interference that may cause undesired operation of the device.

Le présent appareil est conforme aux CNR d'Industrie Canada applicables aux appareils radio exempts de licence. L'exploitation est autorisée aux deux conditions suivantes : (1) l'appareil ne doit pas produire de brouillage, et (2) l'utilisateur de l'appareil doit accepter tout brouillage radioélectrique subi, même si le brouillage est susceptible d'en compromettre le fonctionnement.

Under Industry Canada regulations, this radio transmitter may only operate using an antenna of a type and maximum (or lesser) gain approved for the transmitter by Industry Canada. To reduce potential radio interference to other users, the antenna type and its gain should be so chosen that the equivalent isotropically radiated power (e.i.r.p.) is not more than that necessary for successful communication.

Conformément à la réglementation d'Industrie Canada, le présent émetteur radio peut fonctionner avec une antenne d'un type et d'un gain maximal (ou inférieur) approuvé pour l'émetteur par Industrie Canada. Dans le but de réduire les risques de brouillage radioélectrique à l'intention des autres utilisateurs, il faut choisir le type d'antenne et son gain de sorte que la puissance isotrope rayonnée équivalente (p.i.r.e.) ne dépasse pas l'intensité nécessaire à l'établissement d'une communication satisfaisante.

RF Exposure Information

This equipment complies with FCC radiation exposure limits set forth for an uncontrolled environment. This equipment should be installed and operated with a minimum distance of 20 cm between the radiator and your body. This transmitter must not be co-located or operated in conjunction with any other antenna or transmitter.

Cet équipement est conforme aux limites FCC d'exposition aux radiations définies pour un environnement non contrôlé. Cet équipement doit être installé et utilisé à une distance minimale de 20cm entre le radiateur et votre corps. Cet émetteur ne doit pas être co-implantés ou exploités en conjonction avec une autre antenne ou émetteur.

Host FCC and IC Label Requirement

On the final installation (e.g., on the enclosure of the final assembly) a label with the FCC and IC information as shown in the figure below must be visible. The font size is to be four-points or larger.

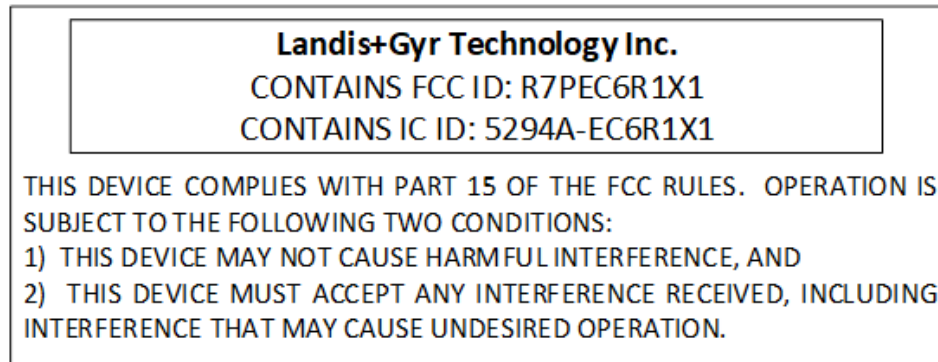

Figure 5. FCC and IC Label

Electrical Characteristics

Battery:

- Battery chemistry: Lithium Manganese
- Battery pack construction: 2 battery cells, size A, connected in parallel
- Nominal voltage: 3.0 V
- Capacity: 4800 mAh

DC Characteristics:

- Operating Voltage Range: 2.4 V - 3.6 V
- Typical Average Sleep Current (at 25°C): 3.0 μ A

Radio Characteristics:

- Typical Antenna Gain: 0 dBi \pm 2dB
- Frequency Range: 902.3 MHz – 927.8 MHz
- Modulation Format: 2-FSK, 2-GFSK
- Transmit Output Power (typical)
 - Single Channel Mode (Tools Connection): -3 dBm
 - Frequency Hopping Mode

- High Power: 27 dBm
- Normal Power (default): 24 dBm
- Receive sensitivity (typical)
 - 9.6 kbps: -112 dBm
 - 10 kbps: -112 dBm
 - 19.2 kbps: -110 dBm
 - 20 kbps: -110 dBm
 - 38.4 kbps: -108 dBm
 - 50 kbps: -108 dBm
 - 150 kbps: -100 dBm
- Max Input Power, No Damage: + 10 dBm